

# FMX AUTOMATIC TRANSMISSION DIAGNOSIS AND SERVICE

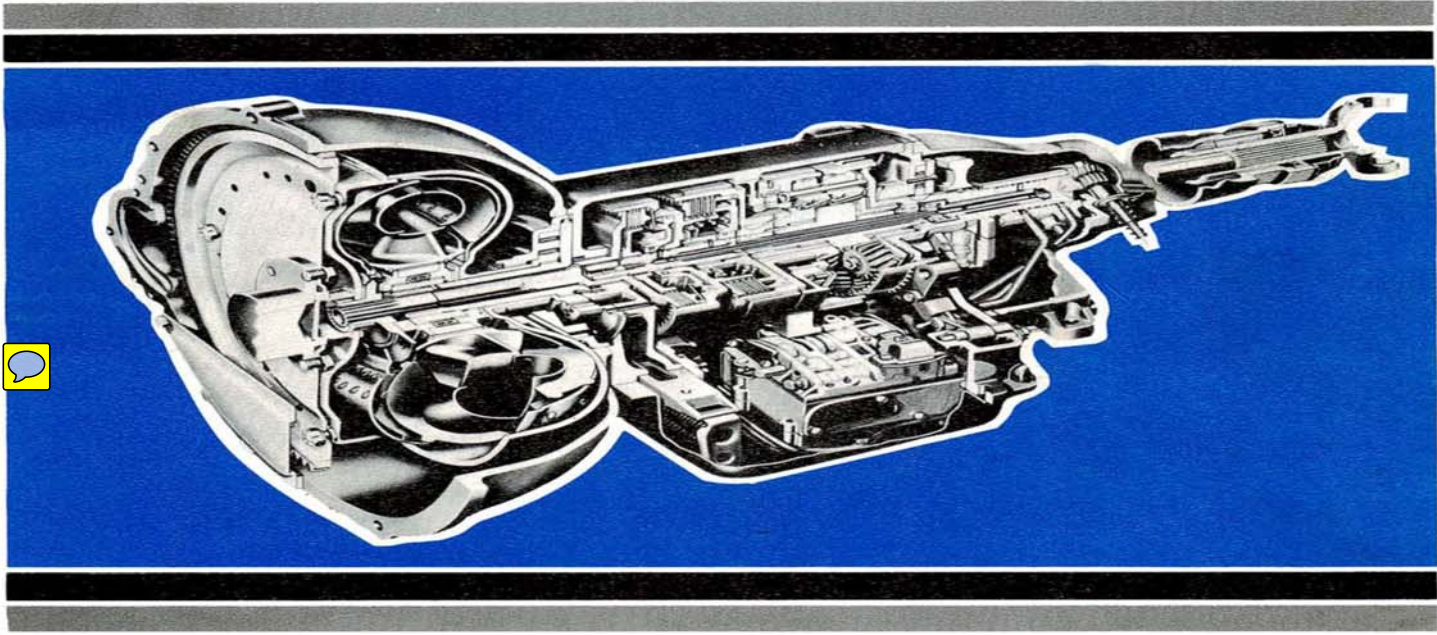

**Includes two additional Ford Manuals**

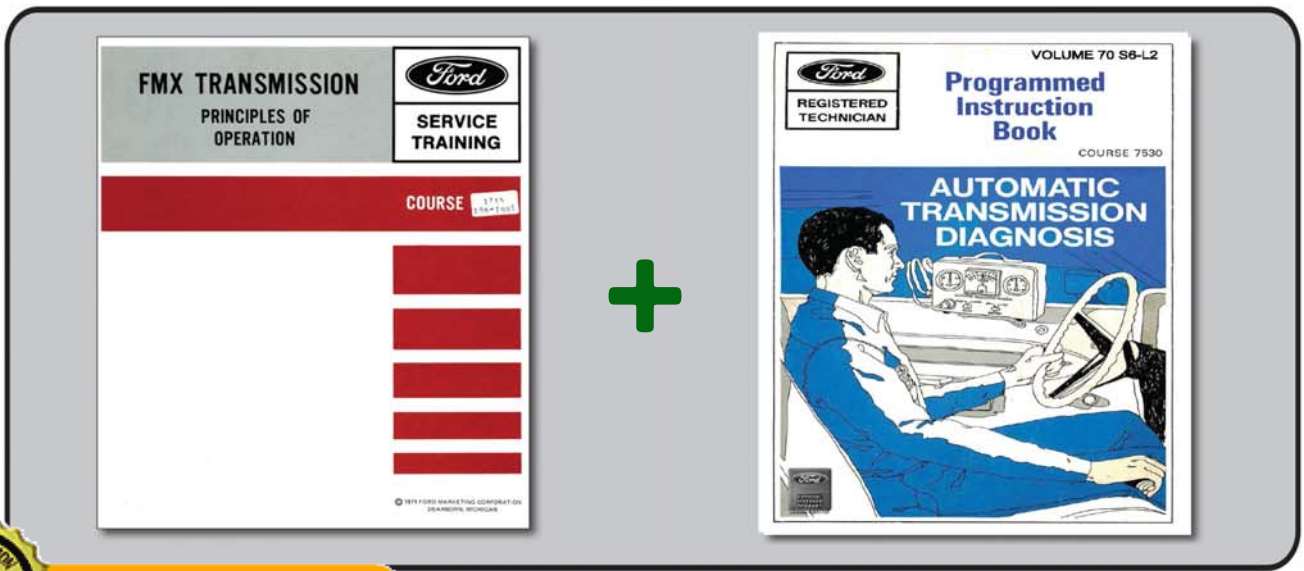

**BUY IT NOW!**

**Click Here To Order**



vision  
is Department



OFFICIAL LICENSED PRODUCT  
License #2011747

Copyright © 2013, Forel Publishing Company, LLC, Woodbridge, Virginia

All Rights Reserved. No part of this book may be used or reproduced in any manner whatsoever without written permission of Forel Publishing Company, LLC. For information write to Forel Publishing Company, LLC, 3999 Peregrine Ridge Ct., Woodbridge, VA 22192

**FMX Automatic Transmission Diagnosis, Service, and Training Manual**  
**EAN: 978-1-60371-199-9**  
**ISBN: 1-60371-199-6**

Forel Publishing Company, LLC  
3999 Peregrine Ridge Ct.  
Woodbridge, VA 22192  
Email address: [sales@ForelPublishing.com](mailto:sales@ForelPublishing.com)  
Website: <http://www.ForelPublishing.com>



This publication contains material that is reproduced and distributed under a license from Ford Motor Company. No further reproduction or distribution of the Ford Motor Company material is allowed without the express written permission of Ford Motor Company.

---

## Note from the Publisher

This product was created from the original Ford Motor Company's publication. Every effort has been made to use the original scanned images, however, due to the condition of the material; some pages have been modified to remove imperfections.

---

## Disclaimer

Although every effort was made to ensure the accuracy of this book, no representations or warranties of any kind are made concerning the accuracy, completeness or suitability of the information, either expressed or implied. As a result, the information contained within this book should be used as general information only. The author and Forel Publishing Company, LLC shall have neither liability nor responsibility to any person or entity with respect to any loss or damage caused, or alleged to be caused, directly or indirectly by the information contained in this book. Further, the publisher and author are not engaged in rendering legal or other professional services. If legal, mechanical, electrical, or other expert assistance is required, the professional should be sought.



# FMX AUTOMATIC TRANSMISSION DIAGNOSIS AND SERVICE

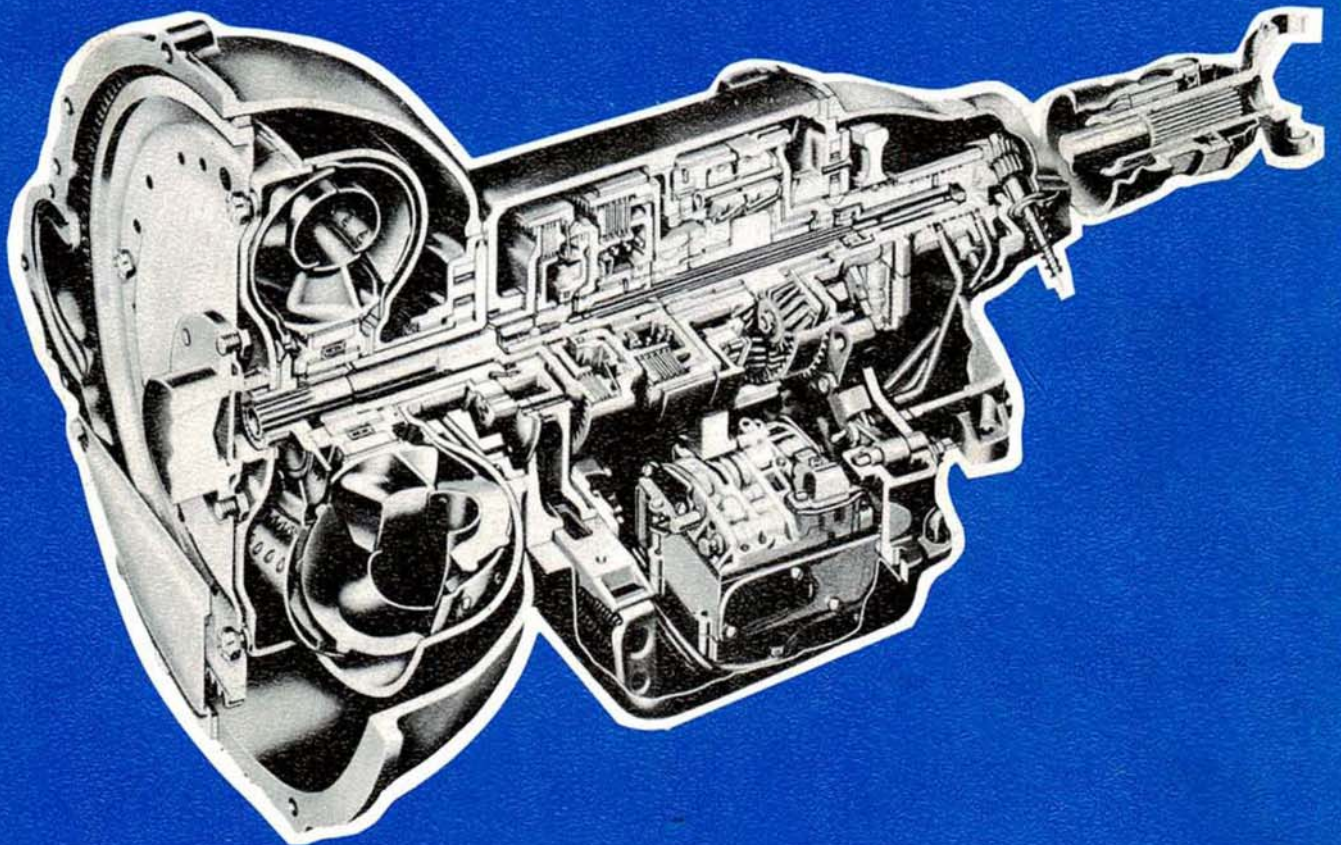

**BUY IT NOW!**

**Click Here To Order**



vision  
is Department



License #2011747

## IMPORTANT SAFETY NOTICE

Appropriate service methods and proper repair procedures are essential for the safe, reliable operation of all motor vehicles as well as the personal safety of the individual doing the work. This manual provides general directions for accomplishing service and repair work with tested, effective techniques. Following them will help assure reliability.

There are numerous variations in procedures, techniques, tools, and parts for servicing vehicles, as well as in the skill of the individual doing the work. This manual cannot possibly anticipate all such variations and provide advice or cautions as to each. Accordingly, anyone who departs from the instructions provided in this manual must first establish that he compromises neither his personal safety nor the vehicle integrity by his choice of methods, tools or parts.

As you read through the procedures, you will come across NOTES, CAUTIONS, and WARNINGS. Each one is there for a specific purpose. NOTES give you added information that will help you to complete a particular procedure. CAUTIONS are given to prevent you from making an error that could damage the vehicle. WARNINGS remind you to be especially careful in those areas where carelessness can cause personal injury. The following list contains some general WARNINGS that you should follow when you work on a vehicle.

- Always wear safety glasses for eye protection.
- Use safety stands whenever a procedure requires you to be under the vehicle.
- Be sure that the ignition switch is always in the OFF position, unless otherwise required by the procedure.
- Set the parking brake when working on the vehicle. If you have an automatic transmission, set it in PARK.
- Operate the engine only in a well-ventilated area to avoid the danger of carbon monoxide.
- Keep yourself and your clothing away from moving parts, when the engine is running, especially the fan and belts.
- To prevent serious burns, avoid contact with hot metal parts such as the radiator, exhaust manifold, tail pipe, catalytic converter and muffler.
- Do not smoke while working on the vehicle.
- To avoid injuries, always remove rings, watches, loose hanging jewelry, and loose clothing before beginning to work on a vehicle.

NOTE: The recommendations and suggestions contained in this publication are made to assist the dealer in improving his dealership parts and/or service department operations. These recommendations and suggestions do not supersede or override the provisions of the Warranty and Policy Manual and in any cases where there may be a conflict, the provisions of the Warranty and Policy Manual shall govern.

The descriptions, testing procedures, and specifications in this handbook were in effect at the time the handbook was approved for printing. Ford Motor Company reserves the right to discontinue models at any time, or change specifications, design or testing procedures without notice and without incurring obligation.



# TABLE OF CONTENTS

	Page No.
<b>INTRODUCTION</b>	
AIM OF COURSE .....	1
TRANSMISSION IDENTIFICATION .....	2
DESCRIPTION .....	2
MAIN TRANSMISSION COMPONENTS AND FUNCTIONS .....	3
TORQUE CONVERTER COMPONENTS AND FUNCTIONS .....	4
TORQUE CONVERTER OPERATION .....	5-6
PLANETARY GEARING SYSTEM .....	6-7
HYDRAULIC CONTROL SYSTEM .....	8-9
VALVE BODY OPERATION .....	10
GOVERNOR OPERATION .....	11
<b>DIAGNOSIS</b>	
CHECK SHEET .....	12-13
FLUID LEVEL AND APPEARANCE .....	14
ROAD TEST .....	15
CLUTCH AND BAND APPLICATION CHARTS .....	15-16
IN SHOP TESTS AND ADJUSTMENTS .....	17
LINKAGE ADJUSTMENTS .....	17
VACUUM SUPPLY TEST .....	18
CONTROL PRESSURE TESTS .....	19-20
GOVERNOR CHECK .....	20
STALL TEST .....	21
FLUID LEAKAGE .....	21-22-23
COOLER FLOW CHECK .....	23
AIR PRESSURE CHECK .....	24
TORQUE CONVERTER NOISE AND VIBRATION .....	24
CONVERTER SPECIAL TOOLS .....	25
CONVERTER DIAGNOSIS .....	26-27
CONVERTER LEAK TEST .....	27
CONVERTER INSPECTION AND CLEANING .....	28
COOLER FLUSHING PROCEDURES .....	28
<b>DISASSEMBLY AND REASSEMBLY PROCEDURES</b>	
TRANSMISSION REMOVAL .....	29
DISASSEMBLY OF CASE .....	30-31-32
TRANSMISSION END PLAY CHECK .....	30
DISASSEMBLY OF COMPONENTS	
EXTENSION HOUSING .....	33
FRONT SERVO .....	34
REAR SERVO .....	35
CONTROL VALVE BODY .....	36-37
PRESSURE REGULATOR .....	38
DOWNSHIFT AND MANUAL LINKAGE .....	39-40
FRONT PUMP .....	40-41
REAR CLUTCH .....	41-42
FRONT CLUTCH .....	43-44
PLANET CARRIER .....	44-45
PRIMARY SUN GEAR SHAFT .....	45
OUTPUT SHAFT .....	46-47
GOVERNOR .....	47-48
REASSEMBLY OF CASE .....	48-52
INSTALLATION .....	52
QUESTIONS .....	53
QUESTIONS .....	54
QUESTIONS .....	55
QUESTIONS .....	57



**BUY IT NOW!**

**Click Here To Order**



# INTRODUCTION

## AIM OF COURSE

This course has been prepared to consolidate into a single handy reference book, the details of the Ford FMX three speed automatic transmission in the areas of:

- Diagnosing
- Testing
- Servicing

The FMX has been around for many years and is currently being used in full size 1979-80 Ford and Mercury cars. Experienced transmission technicians could probably write a book based upon their own knowledge and experiences. However, this course is written so the technician with little or no knowledge of automatic transmissions can learn the FMX operations by reading the following sections and studying the diagrams. If possible, the new technician should conduct a tear-down and rebuild of an actual unit while following the steps provided in this booklet.

The automatic transmission used in the modern automobile is a complex mechanism which dependably transmits driving power from the engine to the rear axle with a minimum of attention. It reacts to various external messages and demands from the driver, the engine, the load being moved and vehicle speed. In response to these external messages and demands, the valve body directs the flow of hydraulic oil to the proper internal clutches and bands to select the correct speed range (Fig. 1).

As with any complex mechanism, careful and complete diagnosis of reported malfunctions is of utmost importance to ensure satisfactory repair in the minimum amount of time. A few extra minutes of diagnosis, testing, setting of engine adjustments and road test can save hours of unnecessary repair time, reduce customer inconvenience and maintain customer goodwill toward both the dealership and the Ford Motor Company.

Suggestions on what to look for and how to diagnose reported malfunctions in a Ford FMX automatic transmission are included with the intent of making it easier for the technician to diagnose and repair the cause of a reported malfunction.

Programmed into the course is a series of self-check questions covering various important points. They are designed to allow a self-evaluation of your understanding and comprehension of the subjects presented, and they are strategically grouped to allow review of the subject just concluded. The answers are located inside the rear cover of this course booklet, and include a brief statement on why the answer given is the correct one. In this way the student gets reinforcement when the question has been answered correctly, or guidance when the answer is wrong.

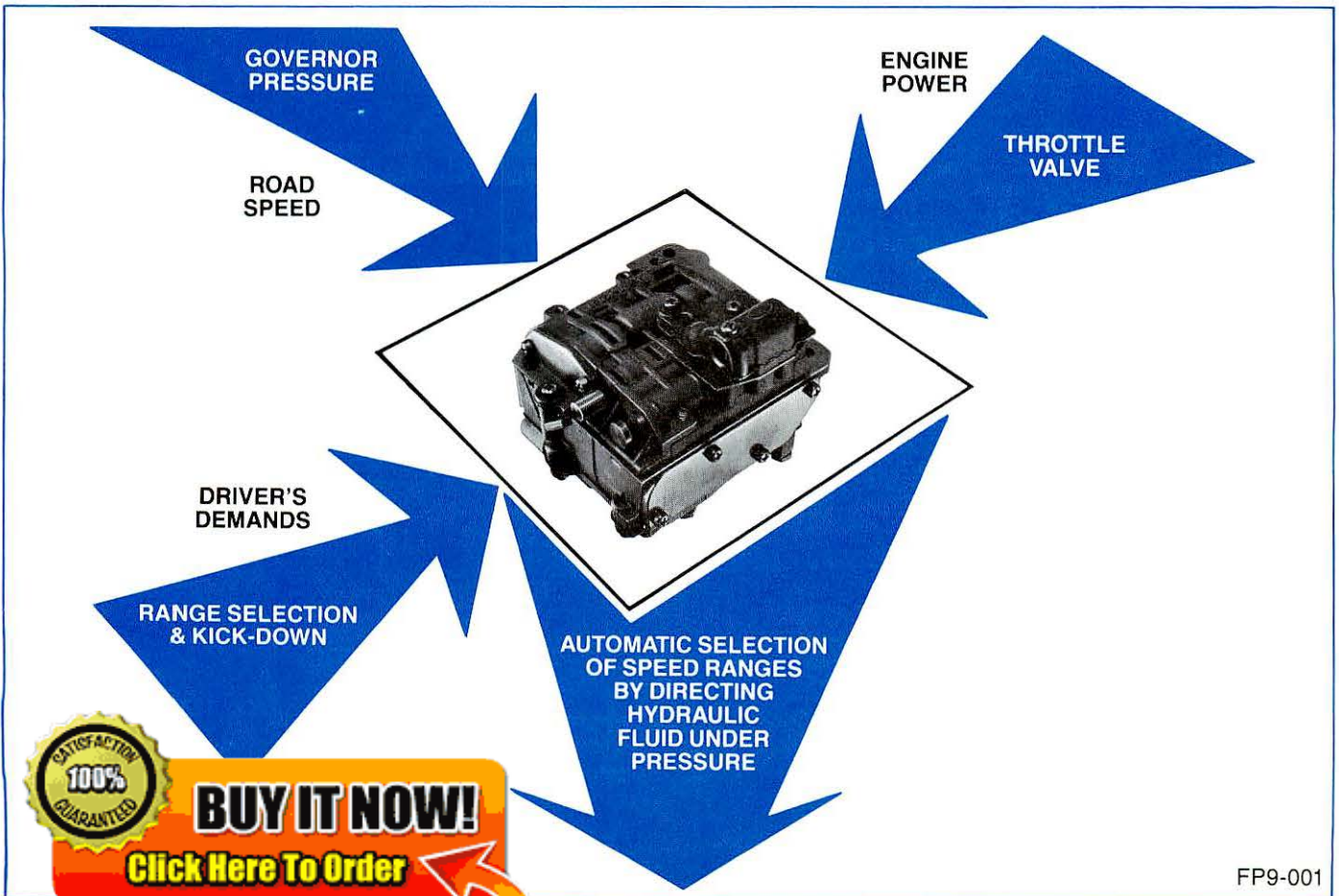

FP9-001



# INTRODUCTION

## MAIN TRANSMISSION COMPONENTS AND FUNCTIONS

Please refer to the key numbers on Figure 5 to identify the transmission main components as follows:

- 1 **TORQUE CONVERTER** — Couples the engine to the transmission planetary gear train; also provides torque multiplication (equivalent to additional gear reduction) in some driving conditions.
- 2 **OIL PUMP** — Provides a constant supply of oil under pressure to operate, lubricate and cool the transmission.
- 3 **INPUT SHAFT** — Provides drive from the torque converter into the planetary gear train.
- 4 **REAR CLUTCH** — Sometimes called the “direct” clutch, it couples the input shaft to the planetary unit sun gear in reverse and high gears.
- 5 **FRONT CLUTCH** — Couples the input shaft to the front planetary unit ring gear in all three forward gears: first (low), second (intermediate) and high (direct drive).
- 6 **COMPOUND PLANETARY GEAR SET** — Provides three forward speeds, plus reverse, depending on clutch and band application.
- 7 **REAR BAND** — Holds the reverse (rear) planet carrier stationary in reverse gear and in selector range 1 (manual low).
- 8 **ONE-WAY CLUTCH** — Holds the reverse (rear) planet carrier stationary in first gear in D (drive) range.

- 9 **REAR SUPPORT-OIL DISTRIBUTOR AND PARKING GEAR** — Provides oil flow passages to and from the governor. Also, when engaged with a stationary parking pawl, in park position, holds the transmission output shaft from turning.
- 10 **GOVERNOR** — Sends a pressure “road speed” signal to the hydraulic system for upshift and downshift control.
- 11 **OUTPUT SHAFT** — Transmits power from the planetary gear set to the driveshaft, rear axle and rear driving wheels. Also holds rear wheels from turning when parking gear is engaged with parking pawl in Park selector position.
- 12 **VACUUM DIAPHRAGM** — Provides an engine load (manifold vacuum) signal to the hydraulic system to control shifting and pressure for clutches and band servo.
- 13 **CONTROL VALVE BODY** — Directs fluid under pressure to torque converter, band servo, clutches and governor to control transmission operation.
- 14 **FRONT BAND** — Holds planetary unit sun gear stationary in second (intermediate) gear. It is operated by the band servo (Figure 1).

All of these functions and operating components will be described in detail in the pages following. Refer back to Figure 5 as you study the book to place each of the components into this brief overview.

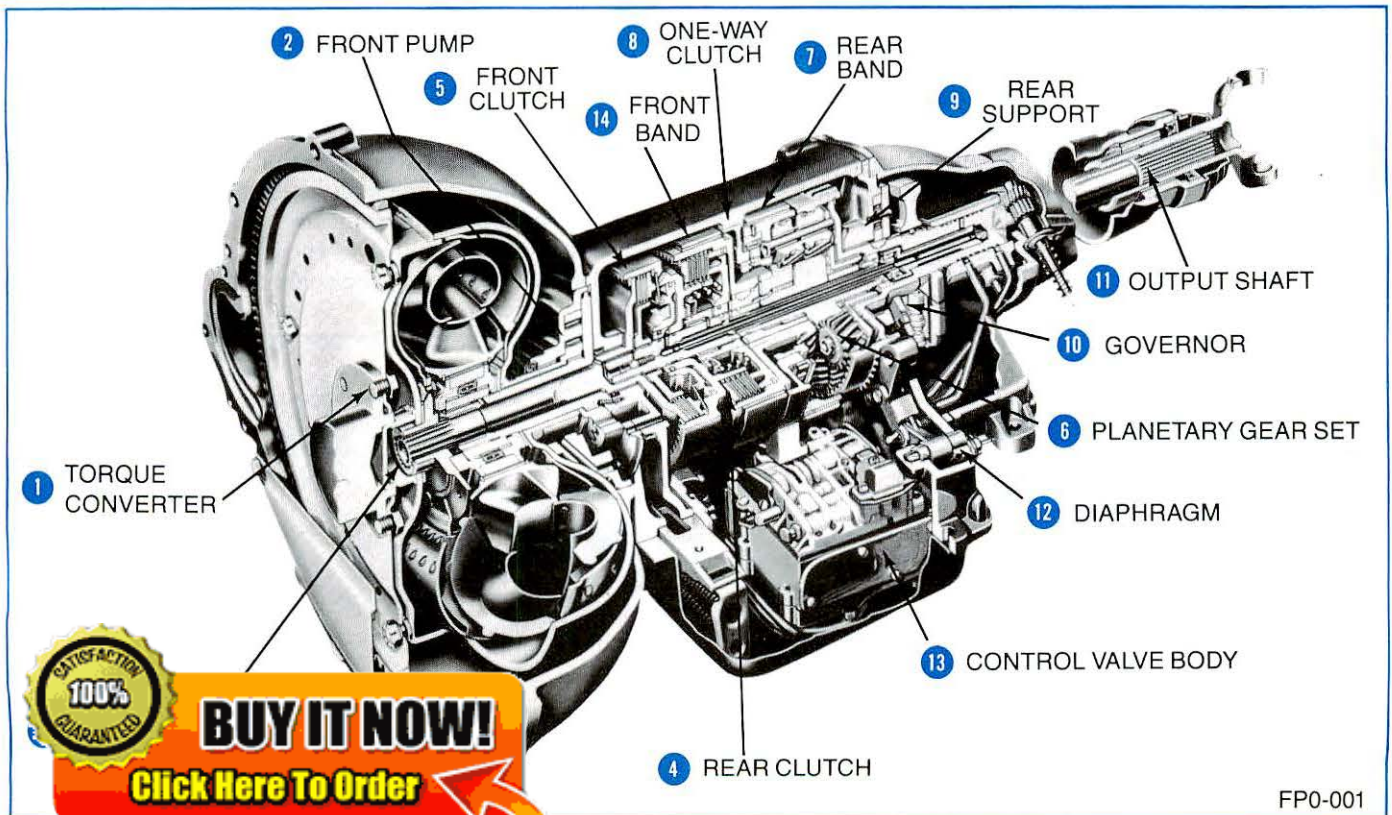

# INTRODUCTION

## TORQUE CONVERTER

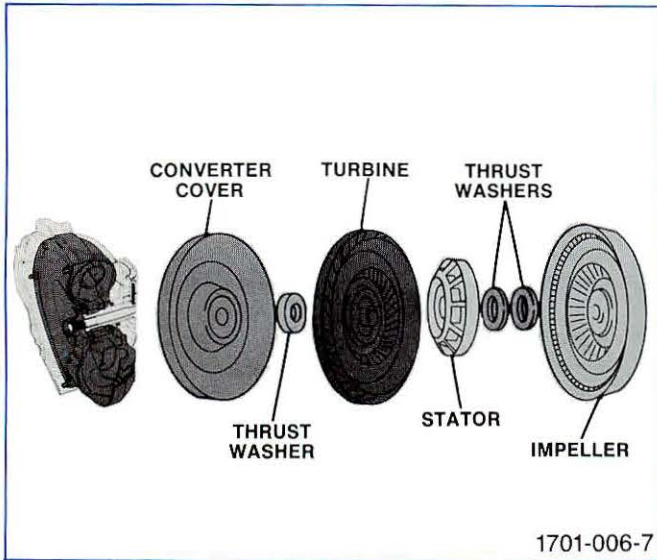

1701-006-7

Fig. 6 - Torque Converter Components

### COMPONENTS OF THE TORQUE CONVERTER

The main components of the converter are:

- *Converter Cover* — encloses the converter at the engine end (front). It is driven through drive studs at the engine speed.
- *Impeller* — welded to the cover, it encloses the converter at the rear and drives the hydraulic oil-fluid pump with its support hub. It is the driving member of the converter. Vanes inside its shell set fluid into motion when it rotates.
- *Turbine* — the driven member of the converter. It is set in rotation by fluid from the impeller vanes. The transmission input shaft is splined to and driven by the turbine.
- *Stator* — the stationary set of vanes in the converter; used to cause speed reduction or torque multiplication.
- *Thrust Washers* — allow the members to turn against one another.

### FUNCTIONS OF THE TORQUE CONVERTER

The converter has four functions:

1. Automatic clutch or coupling. It provides a smooth transfer of engine torque to the transmission gear train.

Engine flywheel. It is attached to a thin flex plate behind the crankshaft rather than a heavy flywheel.

g, it provides additional output torque to

of clutch and band

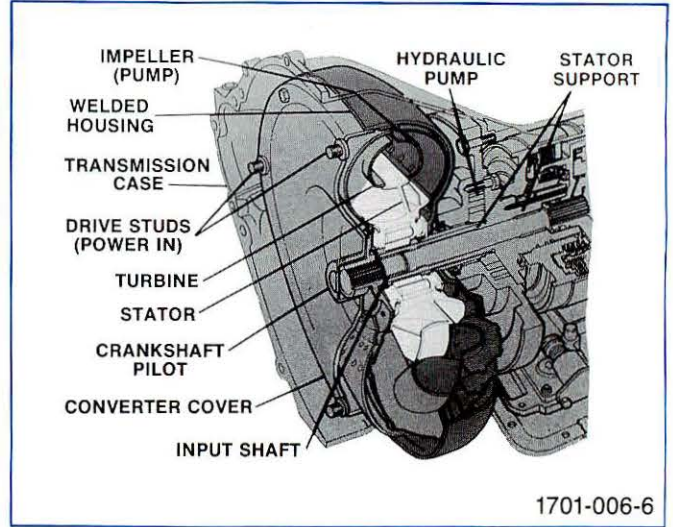

1701-006-6

Fig. 7 - Torque Converter Cutaway

### Description of Converter

It is a welded assembly mounted behind the engine with flex-plate drive studs and a hub that pilots in the end of the crankshaft.

The rear hub of the impeller is supported on the “stator support,” which is the front pump bushing of the hydraulic pump assembly. This hub drives the pump whenever the engine is running.

Output from the torque converter is through the transmission input shaft. The input shaft will turn from about one-half engine speed to nearly full engine speed, depending on the torque demand of the car.

There is no mechanical connection between the impeller and the turbine, which is splined to the transmission input shaft. The converter acts as an automatic clutch with the engine driving the impeller mechanically, the impeller driving the turbine hydraulically and the turbine driving the gear train mechanically. There is no neutral or disengaged clutch position in the converter. The only neutral is in the gear train.

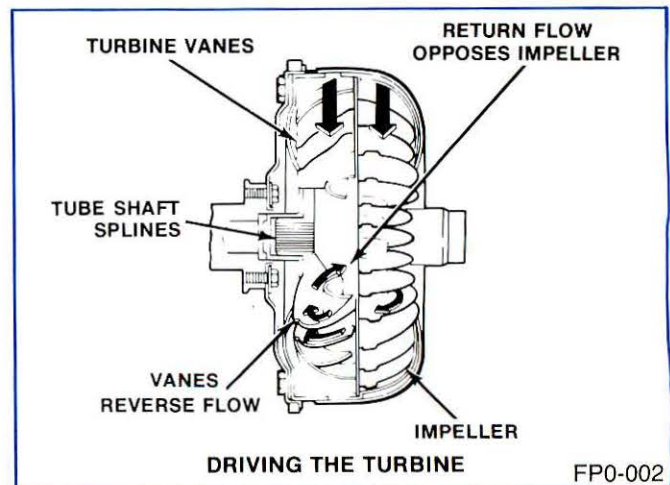

FP0-002

Fig. 8 - Torque Converter Fluid Flow

**100% SATISFACTORY GUARANTEED**

**BUY IT NOW!**

**Click Here To Order**

PayPal, American Express, Discover, MasterCard, VISA

# INTRODUCTION

## TORQUE CONVERTER OPERATION

### IMPELLER PUMPS FLUID

The purpose of the impeller is the same as any pump — to put the fluid in motion. Inside the impeller housing (Fig. 8), many curved vanes, along with an inner ring, form passages for the fluid to flow through. The rotating impeller acts very much like a centrifugal pump. Fluid is supplied by the hydraulic control system, and flows into the passages between the vanes. When the impeller turns, the vanes accelerate the fluid and centrifugal force pushes the fluid outward so that it is discharged from openings around the inner ring. The curvature of the impeller vanes directs the fluid toward the turbine, and in the same direction as impeller rotation.

### FORCE ON TURBINE

The vanes in the turbine are curved opposite to the impeller, and the impact of the moving fluid on the turbine vanes (Fig. 8) exerts a force that tends to turn the turbine in the same direction as impeller rotation. When this force creates a great enough torque on the transmission input (turbine output) shaft to overcome the resistance to motion, the turbine begins to rotate.

Now the impeller and turbine are acting as a simple fluid coupling, but we have no torque multiplication yet. To get torque multiplication, we must return the fluid from the turbine to the impeller and accelerate the fluid again to increase its force on the turbine.

### REVERSING THE FLOW

To get maximum force on the turbine vanes when the moving fluid strikes them, the vanes are curved to reverse the direction of flow (Fig. 8). Less force would be obtained if the turbine deflected the fluid instead of reversing it. At any stall condition, that is, with the transmission in gear and the engine operating, but the turbine standing still, the fluid is reversed by the turbine vanes and pointed back to the impeller. You can see, that without the stator, any momentum left in the fluid after it leaves the turbine would resist the rotation of the impeller.



### STATOR AND ONE-WAY CLUTCH

The stator reverses the fluid again (Fig. 9) and returns it to the impeller in the direction of impeller rotation. A one-way clutch prevents the force of this fluid from turning the stator opposite the impeller and turbine.

As the fluid flows from the stator to the impeller, the impeller has another opportunity to accelerate the same fluid, and it does so. The fluid leaves the impeller with perhaps twice the energy it had the first time, and exerts a greater force on the turbine.

### VORTEX FLOW

We call the flow of fluid through the impeller, to the turbine, to the stator, and back through the impeller, the vortex flow. At high impeller speed and low turbine speed, the vortex flow velocity is the sum of the impeller produced velocity, plus the velocity of the fluid returning from the turbine and stator. It is vortex flow that gives us torque multiplication.

### TORQUE MULTIPLICATION

By torque multiplication, we mean that there is more torque on the turbine shaft than the engine is putting out — because the vortex fluid is accelerated more than once. Torque multiplication is obtained at the sacrifice of turbine rotation. Actually, it's no different from mechanical advantage which you get from gearing down. You gain torque by sacrificing motion.

Torque multiplication takes place anytime the turbine is turning at less than 9/10 impeller speed. At full stall, the FMX converter produces a 2.1 to 1 torque multiplication. As the turbine speed increases in relation to the impeller, torque multiplication decreases.

### ROTARY FLOW

Vortex flow is not the only fluid force trying to turn the turbine. The vortex flow leaving the impeller is not only flowing out of the impeller at high speed, but it is also rotating faster than the turbine. As this rotating fluid strikes the slower turning or stationary turbine, it exerts a turning force against the turbine. This is referred to as the rotary flow.

### COUPLING PHASE

When the coupling phase is reached — that is, when the turbine speed is about 9/10 impeller speed — there is no longer any torque multiplication. The converter then is simply transmitting engine torque to the gear train.

As the turbine begins to rotate and steadily picks up speed, the vortex flow steadily loses speed because of the increasing centrifugal force acting against the flow through the turbine. The rotating impeller produced a centrifugal force in the fluid which caused it to flow from the center outward. The same centrifugal force is acting in the rotating turbine, trying to prevent the fluid from flowing inward. As the vortex flow slows down, torque multiplication is reduced.

# FMX TRANSMISSION

PRINCIPLES OF  
OPERATION



**SERVICE  
TRAINING**

**COURSE**

1715  
106-INN1



**BUY IT NOW!**

**Click Here To Order**



PayPal

Discover  
Cards

DISCOVER  
NEWUS

MasterCard

VISA

© 1971 FORD MARKETING CORPORATION  
DEARBORN, MICHIGAN

## DRIVING RANGES OF THE FMX TRANSMISSION

The selector lever has 6 positions; P (Park), R (Reverse), N (Neutral), D (Drive), 2 (Two), and 1 (One).

### D, DRIVE

The normal automatic driving range on the current transmission is D; in this range (which is the same in all respects as D1 range in the earlier models) the car starts off in first gear and gives the best combination of automatic gear shifts, to provide for economy and full-power starts. As the accelerator is depressed and the car picks up speed, automatic shifts to second and high gears will occur. The transmission will automatically downshift as speed decreases. Forced downshifts in D are made in the same manner as with the conventional earlier models.

### 2, SECOND GEAR HOLD

With the shift lever in 2, the car will start off and **remain** in second gear, regardless of throttle opening or road speed. This range is especially useful for starting the car on icy pavements or other slippery surfaces. Also, when engine braking is required and the selector lever is moved from D to 2, the transmission will engage and **remain** in second gear. The 2 range is not a cruising range in the usual sense of the term. While the transmission is capable of limited cruising in second gear, maximum fuel economy and best all-round cruising performance are realized in D.

### 1, LOW

The 1 range on the current transmission is identical in operation to manual low range on the earlier models, except that when the transmission shift lever is moved to 1 to provide engine braking, the automatic shift from second to low gear will occur at 19-33 mph.

P (Park), R (Reverse) and N (Neutral), are the same as the equivalent ranges on the conventional earlier models.



**100% SATISFACTION GUARANTEED**

**BUY IT NOW!**

**Click Here To Order**

PayPal American Express Discover MasterCard VISA

12-70



## TORQUE CONVERTER OPERATION

In construction and operation, the torque converter is typical of all Ford torque converters. The torque converter consists of three main parts: the **impeller** (pump), the **turbine**, and the **stator**. The impeller is driven by the engine crankshaft through a flywheel mounted on the engine crankshaft. The turbine, which is mounted on the input shaft, is driven by the fluid pumped into it by the impeller. The stator is mounted on a one-way clutch. All of these parts are enclosed in a fluid-filled housing. The transmission hydraulic control system keeps the converter full of fluid and under pressure, when it is operating. It also provides a continuous flow of fluid in and out of the converter.

The **impeller**, or pump, consists of curved blades mounted around the inside of a housing which is driven by the engine. An inner ring locks the blades in place and forms fluid passages. As the impeller rotates, fluid is forced through the curved fluid passages and into the turbine.

The **turbine**, or driven member, is similar to the impeller except that it has blades curved in the opposite direction to the impeller blades. Fluid from the impeller strikes the turbine blades and causes the turbine shaft to rotate in the same direction as the impeller. The torque applied to the turbine is proportional to the velocity of the fluid flowing through it.

The fluid leaving the turbine returns to the impeller by a third set of blades known as the **stator**. The stator is attached to the stator support on the transmission case by a one-way clutch which permits the stator to rotate only in the same direction as the impeller. The clutch locks the stator to the fixed stator support to prevent counterclockwise rotation.

Let's take a look at the torque converter operation under various driving conditions. Let's start with the car standing still at a red light, with the engine operating at normal (hot) idle, and the selector in the Drive position.

The converter housing and impeller is turning at engine crankshaft speed. Centrifugal force acting upon the fluid rotating along with the impeller causes it to flow outward as shown. The fluid flows through the turbine and stator and back to the impeller. The turbine is stationary, because it is locked mechanically to the rear wheels and the fluid flow forces acting on the turbine are not strong enough to turn the rear wheels.



**100% SATISFACTION GUARANTEED**

**BUY IT NOW!**

**Click Here To Order**

PayPal American Express Discover MasterCard VISA

## TORQUE CONVERTER OPERATION – Continued

The turbine blades are curved to produce the greatest practicable change of direction in the fluid flowing through it. When the turbine is stationary, and at low rotary speeds, the fluid flow leaving it is aimed for a head-on collision with the rotating impeller blades. To prevent this collision, stator blades are installed between the turbine outlet passages and the impeller inlet passages. The stator blades are locked against counterclockwise rotation by a one-way roller clutch. The stationary stator blades force the fluid to make a U-turn and flow back into the impeller at an angle that helps impeller rotation.

Let's return to our car at the red light. Let's say the light turns green, and the driver depresses the accelerator pedal to drive off. As the throttle is advanced, engine and impeller speeds increase rapidly, while turbine speed increases slowly with car road speed. This difference in impeller and turbine speeds permits the impeller to build up the velocity of the fluid flow through the turbine and stator and back into the impeller. This flow is referred to as the **vortex flow**.

This buildup in the vortex flow velocity causes a greater torque to be applied against the turbine than the engine is applying against the impeller. At high impeller speed and low turbine speed, the vortex flow velocity is the sum of the impeller produced velocity, plus the velocity of the fluid returning from the turbine and stator. In the torque converter, engine torque may be multiplied as much as 2.1 times. This increase in vortex flow velocity is made at the expense of turbine rotation. The turbine is turning slower than the impeller. This can be compared to a gear reduction in which torque at the output shaft is multiplied, but output shaft speed is reduced.

This vortex flow is not the only fluid force trying to turn the turbine. The vortex flow leaving the impeller is not only flowing out of the impeller at high speed, but is also rotating faster than the turbine. As this rotating fluid strikes the slower turning or stationary turbine, it exerts a turning force against the turbine. This is referred to as the **rotary flow**.

As the turbine begins to rotate and steadily picks up speed, the vortex flow is steadily losing speed because of the steadily increasing centrifugal force acting against the flow through the turbine. The rotating impeller produced a centrifugal force in the fluid which caused it to flow from the center outward. The same centrifugal force is acting in the rotating turbine, trying to prevent the fluid from flowing inward. As the vortex flow slows down, torque multiplication is reduced.



## TORQUE CONVERTER OPERATION – Continued

Along with this steady increase in turbine speed and decrease in vortex flow speed, there is a continuous change in the angle at which the fluid leaves the turbine. When turbine speed reaches about 9/10 impeller speed, the flow leaving the turbine strikes the back side of the stator. At this point, the stator clutch unlocks and permits the stator to rotate clockwise. The converter is now in its coupling phase and torque multiplication has stopped. The converter is now merely transmitting engine torque from impeller to turbine.

This coupling phase is reached when input torque and output torque requirements come near enough to balance so that the turbine can run at 9/10 impeller speed. This means that, at a light-throttle start, the coupling point is reached in a shorter time and at a lower road speed than it would at a heavier throttle start. At the heavier throttle, it will take a longer time and a higher road speed before the turbine comes up to 9/10 of impeller speed.

Let's return to our car driving off on the green light. We are now cruising at steady throttle at 45 mph. Ahead, we see another traffic light about to go red, so we get off the accelerator pedal. The rear wheels are now driving the engine. In the converter, the turbine becomes the driving member and the impeller the driven member.

The operation of the converter in reverse is the same as in forward gears.

Let's discuss some aspects of the converter that we may have missed. Since vortex flow speed is governed by the difference between impeller and turbine speed, the torque converter automatically adjusts converter input to drive shaft torque requirements.

When the drive shaft torque requirements become greater than the engine output torque, the turbine slows down and causes an increase in vortex flow velocity and thereby, an increase in torque multiplication. This automatic adjustment between torque input and output permits the converter to absorb the shock of sudden ratio changes (gear shifts) in the planetary gear set, especially at the lower road speeds.

If we are driving an FMX automatic transmission and cruising at 30 mph in high gear, then suddenly depress the accelerator pedal to less than a full-throttle downshift position, we hear the engine speed increase rapidly, while the road speed will increase somewhat slower. In this case, it is not entirely accurate to say that the converter is slipping. (There is, of course, some slippage in the converter at all times.) It is more accurate, in this instance, to say that the torque converter has automatically adjusted itself to produce a greater engine torque multiplication to increase drive shaft speed. Torque multiplication can occur in the converter only when the turbine rotates at less than 9/10 impeller speed.



ENGINE CRANKSHAFT

PUMP DRIVE HUB

ONE-WAY CLUTCH

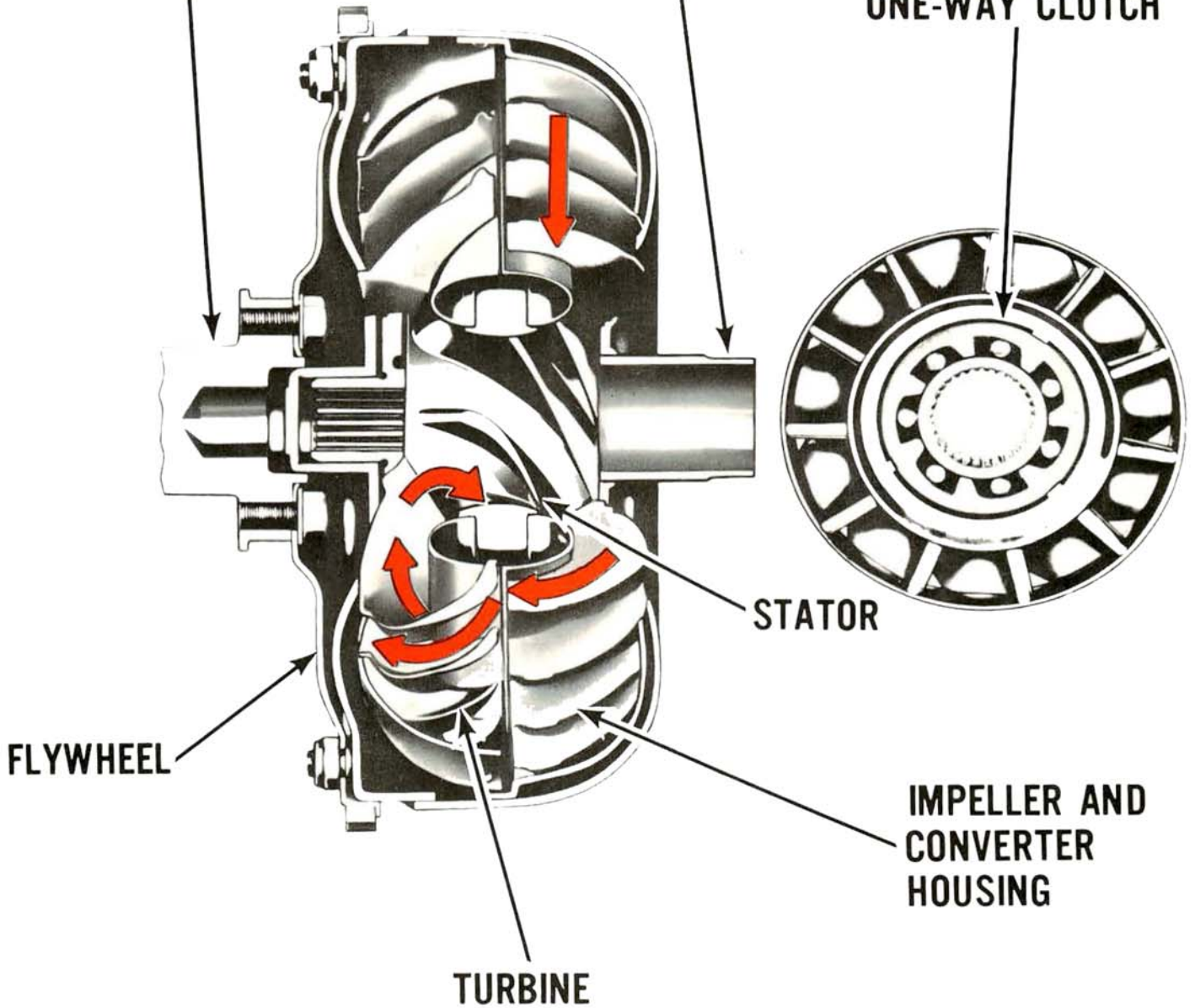

STATOR

FLYWHEEL

IMPELLER AND  
CONVERTER  
HOUSING

TURBINE

## TORQUE CONVERTER OPERATION



**BUY IT NOW!**

**Click Here To Order**

PayPal

Discover  
Cards

Discover  
Novus

MasterCard

VISA

7501-2

12-70

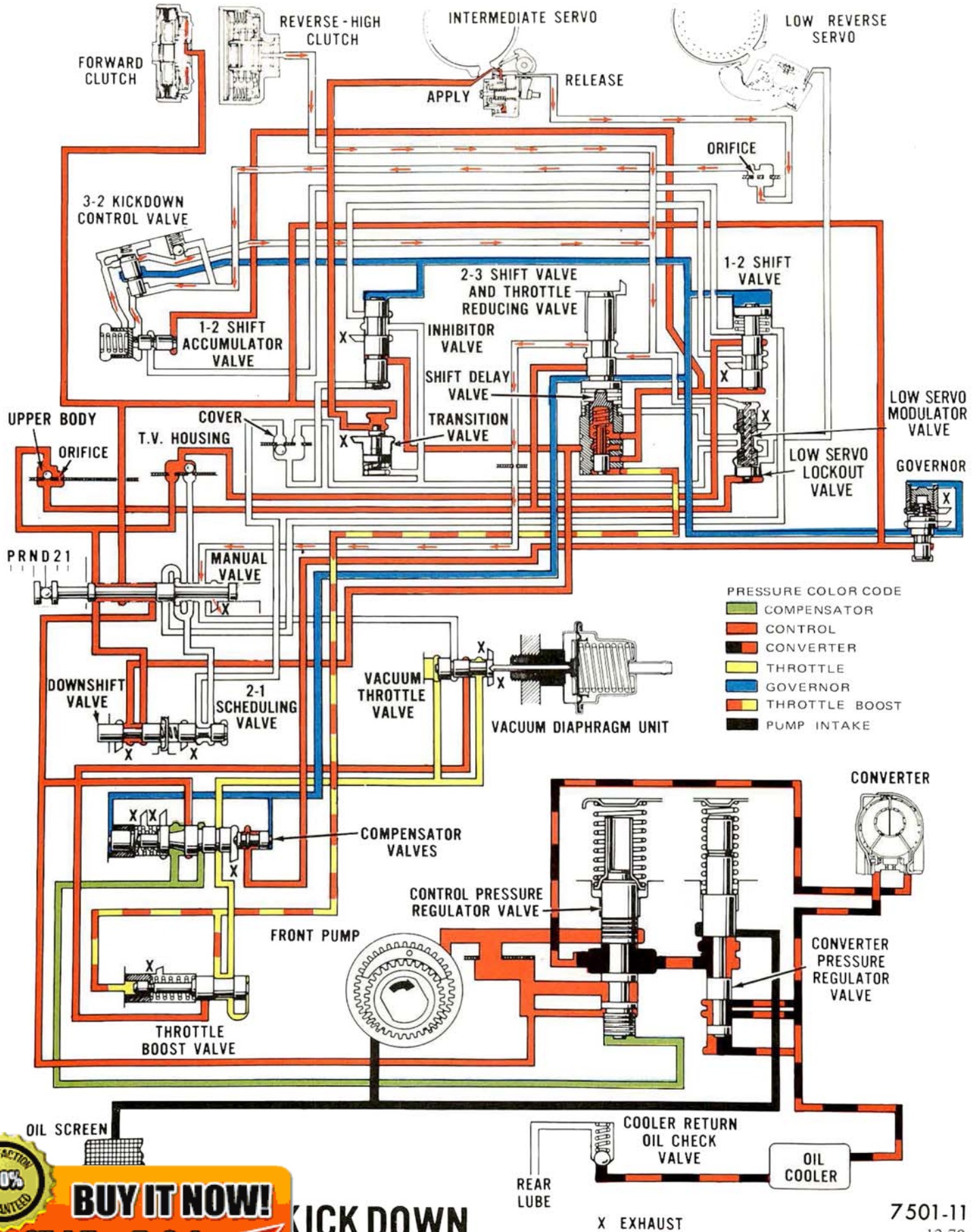

**BUY IT NOW!**

**Click Here To Order**

**KICK DOWN**



7501-11  
12-70



VOLUME 70 S6-L2

# Programmed Instruction Book

COURSE 7530

## AUTOMATIC TRANSMISSION DIAGNOSIS

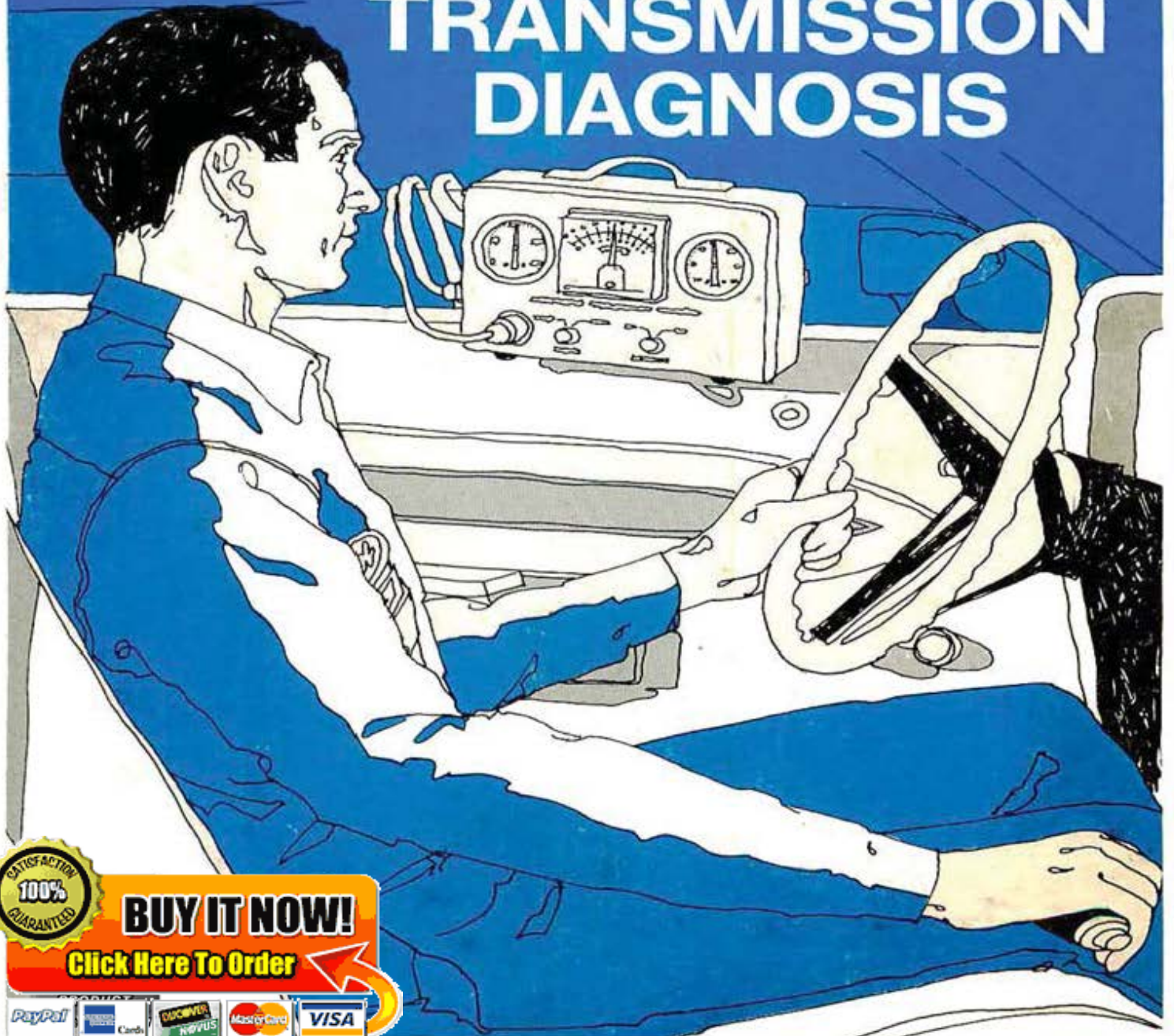

**BUY IT NOW!**

**Click Here To Order**



# AUTOMATIC TRANSMISSION DIAGNOSIS



FORD DIVISION  
National Service Office  
FIRST PRINTING — MARCH 1970

© 1970 FORD MOTOR COMPANY  
DEARBORN, MICHIGAN

The descriptions, testing procedures, and specifications in this handbook were in effect at the time the handbook was approved for printing. Ford Motor Company reserves the right to discontinue models at any time, or change specifications, design or testing procedures without notice and without incurring obligations.



**BUY IT NOW!**

**Click Here To Order**

PayPal

Discover  
Cards

Discover  
NewUS

MasterCard

VISA

# TABLE OF CONTENTS

	Page
Objectives .....	C
Introduction .....	D
Sample Lesson .....	E
<b>Part I — Diagnosis Guide</b>	
Lesson 1 — Use of the Guide .....	3
Lesson 2 — Location of Service Procedures .....	5
<b>Part II — Fluid Checks</b>	
Lesson 3 — Checking the Fluid Level .....	9
Lesson 4 — Dipstick Identification .....	15
Lesson 5 — Adding Fluid .....	17
Lesson 6 — Interpreting Fluid Condition .....	19
<b>Part III — Linkage Checks and Engine Idle</b>	
Lesson 7 — Accelerator (Throttle) Linkage .....	29
Lesson 8 — Downshift Linkage .....	31
Lesson 9 — Manual Linkage .....	33
Lesson 10 — Engine Idle .....	35
<b>Part IV — Shift Speeds</b>	
Lesson 11 — Specifications for Shift Speeds .....	39
Lesson 12 — Shift Test Preparation (In Shop) .....	41
Lesson 13 — Light Throttle Shift Tests .....	43
Lesson 14 — Torque Demand Shift Test .....	47
Lesson 15 — Wide-Open Throttle Shift Test .....	49
<b>Part V — Pressure Testing</b>	
Lesson 16 — Automatic Transmission Tester — Engine Connections .....	53
Lesson 17 — Automatic Transmission Tester — Vacuum Gauge Connection .....	55
Lesson 18 — Automatic Transmission Tester — Pressure Gauge Connection .....	57
Lesson 19 — Vacuum Supply and T.V. Diaphragm OK .....	59
Lesson 20 — Pressure Testing by Vacuum Pump Method .....	61
Lesson 21 — Recording Pressure Test Results .....	63
Lesson 22 — Interpreting Pressure Test Results .....	65
<b>Part VI — Governor Checks</b>	
Lesson 23 — Preparation for Governor Check .....	69
Lesson 24 — Governor Check on C4, C6 .....	71
Lesson 25 — Governor Check on FMX .....	75
<b>Part VII — Fluid Cooler Flow Check</b>	
Lesson 26 — Preparation for Fluid Cooler Flow Check .....	79
Lesson 27 — Checking Fluid Cooler Flow .....	81



**BUY IT NOW!**

**Click Here To Order**



# TABLE OF CONTENTS

	Page
Part VIII — Stall Testing	
Lesson 28 — Preparation for Stall Test	85
Lesson 29 — Stall Test Procedure	87
Lesson 30 — Interpreting Stall Test Data	89
Part IX — Diagnosis Charts	
Lesson 31 — How to Use Diagnosis Charts	93
• Slow Initial Engagement	92
• Rough Initial Engagement in Either Forward or Reverse	94
• No Drive in Any Gear	96
• No Drive Forward — Reverse OK	98
• No Drive, Slips or Chatters in Reverse — Forward OK	100
• No Drive, Slips or Chatters in First Gear in D.	
All other Gears Normal	102
• No Drive, Slips or Chatters in Second Gear	102
• Starts in High in D; Drag or Lockup at 1-2 Shift Point	
or in 2 or 1	104
• Starts Up in 2nd or 3rd But No Lockup at 1-2 Shift Points	106
• Shift Points Incorrect	108
• No Upshift at Any Speed	110
• Shifts 1-3 in D	112
• Engine Overspeeds on 2-3 Shift	114
• Mushy 1-2 Shift	116
• Rough 1-2 Shift	118
• Rough 2-3 Shift	118
• Rough 3-1 Shift at Closed Throttle in D	120
• No Forced Downshifts	122
• No 3-1 Shift in D	122
• Runaway Engine on Forced 3-2 Downshift	126
• No Engine Braking in Manual First Gear	128
• No Engine Braking in Manual Second Gear	130
• Transmission Noisy — Valve Resonance	132
• Transmission Noisy — Other Than Valve Resonance	134
• Transmission Overheats	136
• Transmission Fluid Leak	138
Part X — Fluid Leakage in Converter Area	
Lesson 32 — Front Pump Seal Leaks	143
Lesson 33 — Front Pump-to-Case Bolt or Gasket Leaks	145
Lesson 34 — Converter Drain Plug Leaks	147
Lesson 35 — Engine Oil Leaks	149
Fluid and Oil Color Identification	151
Converter Area Cleaning and Leakage	
Diagnosis	153
	155

**100% SATISFACTION GUARANTEED**

**BUY IT NOW!**

**Click Here To Order**

PayPal American Express Discover MasterCard VISA

# OBJECTIVES

This programmed instruction book is designed to teach you to diagnose the various troubles that may occur in Ford automatic transmissions. As you complete this course, you should be able to:

1. Locate specific procedures in the appropriate shop manuals for checks and adjustments that are part of the diagnosis procedure.
2. Use the Automatic Transmission Diagnosis Guide to record your test findings and diagnose the failure cause.
3. Follow the appropriate "road map" Diagnosis Charts in locating the causes of specific complaints.
4. Properly connect necessary test equipment used in the diagnosis procedures.
5. Perform and correctly interpret fluid checks, shift speed checks, pressure tests, governor checks, fluid cooler flow checks and stall tests.
6. Locate the origins of external leakage from the transmission or other components near the transmission, which cause oil to be deposited on the transmission.
7. Determine what specific repair procedure is required to correct the diagnosed problem and restore proper operation.

It is assumed that, prior to studying this book, you already have the technical knowledge and skills needed to repair and adjust the automatic transmission components used on Ford cars.

**NOW PLEASE READ THE COURSE INTRODUCTION ON PAGE D FOLLOWING.**



**BUY IT NOW!**

**Click Here To Order**



# INTRODUCTION

This programmed instruction book is divided into a number of small units or lessons designed to help you learn quickly and easily. The lessons are presented in the sequence of the normal automatic transmission diagnosis procedure.

Using this method, you will build your knowledge step by step. Be certain that you understand each lesson before proceeding to the following lesson. There is no need to hurry. You can put the book aside at any time and later resume your study where you left off.

## PROGRAMMED INSTRUCTION FORMAT

To help you learn more effectively, the material is presented in a programmed instruction format. You will be asked a number of questions as your study proceeds. Each time you encounter a question, select the best answer and **mark your answer on the answer sheet you'll find at the back of the book.** Then, turn to the page the answer directs you to, and check your answer. When you turn to the page, read **only** the material that corresponds to your specific answer at that point, as identified by the question number and the answer letter. For example, 15B would designate that you chose answer B to question 15. From then on, simply follow the instructions the book gives you for reviewing material as necessary and proceeding to the next lesson.

The answer sheet is for **your** use only; it will not be checked or examined by anyone else. The course material is not designed to see how well you score, but to help you learn the material effectively.

**Now, before you begin the course:**

- 1. Remove the answer sheet from the back of the book.**
- 2. Work the "sample lesson" on page E following.**



# SAMPLE LESSON

In this course book, you will deal with three basic automatic transmission designs: the FMX, the C4 and the C6.

The FMX design goes farthest back into Ford history, having evolved through several stages of refinement from the first Fordomatic and Mercomatic design. The C4 transmission was an entirely new design when released in 1964 for use with lower torque engines. Model C6, with the same design gear train as the C4, was released in 1966 for use with higher torque engines.

**AFTER YOU STUDY THE FOLLOWING MATERIAL, PLEASE RESPOND TO THE FOLLOWING QUESTION BY MARKING "A" OR "B" ON YOUR ANSWER SHEET OPPOSITE "SAMPLE LESSON."**

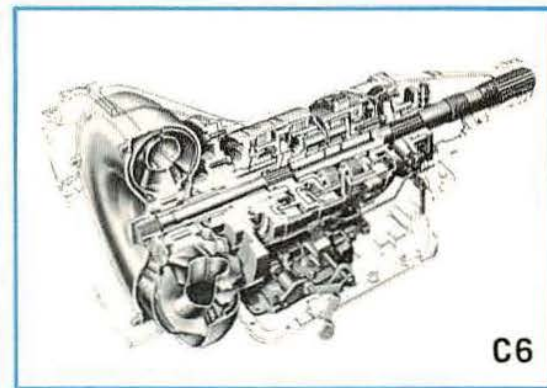
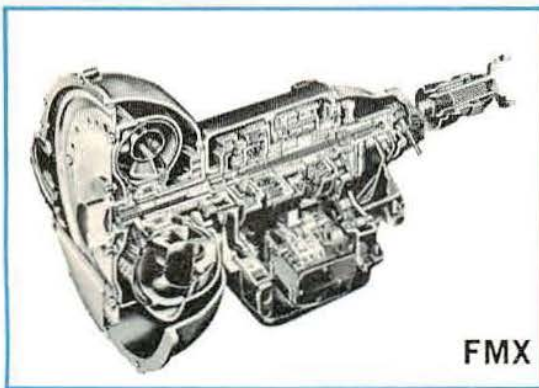
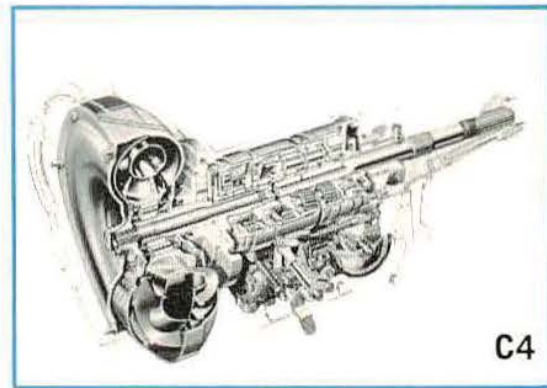

FIGURE A — FORD AUTOMATIC TRANSMISSIONS

## SAMPLE Question:

Which of the following are most similar in design:

A. FMX and C4 . . . turn to page F.

and C6 . . . turn to page 4.

**100% SATISFACTION GUARANTEED**

**BUY IT NOW!**

**Click Here To Order**



## **SAMPLE Answer A:**

You said that the FMX and C4 are most similar in design from the choices given. While there are similarities, these units have entirely different gear trains and hydraulic control systems. However, the C4 and C6 are very close in design as the lesson and pictures show.

Turn back to page E and compare the pictures in Figure A; then choose answer B.

NEED TO LESSON 1 ON PAGE 3.



**BUY IT NOW!**

**Click Here To Order**



# PART I

# DIAGNOSIS GUIDE



**BUY IT NOW!**  
Click Here To Order 



## AUTOMATIC TRANSMISSION DIAGNOSIS GUIDE (FOR ALL FORD PASSENGER VEHICLES & LIGHT TRUCKS)

**General:** This form must be completely filled in throughout the steps required to diagnose the problem and attached to Forms 1863 covering the correction of transmission malfunction complaints (e.g., erratic shifting, slippage during shifts, failure to shift, harsh and delayed shifts, noise, etc.). It is not necessary to complete this form on complaints involving external leaks.

Transmission Model \_\_\_\_\_ Transmission Date Code/or Serial No. \_\_\_\_\_  
 R.O. No. \_\_\_\_\_ Axle Ratio \_\_\_\_\_ Tester \_\_\_\_\_

### DIAGNOSIS PROCEDURE

Following steps will provide complete data necessary to perform an accurate diagnosis of transmission difficulties.  
 (Note: Items 1, 2, 3 and 5 also should have been performed during pre-delivery)

1. Check transmission fluid level  Full  Overfilled  Low
2. Engine idle: (RPM)

ENGINE (CID)      RECORD SPECIFICATION      THERMACTOR      AS RECEIVED      SET TO

YES    NO

3. Check kickdown and manual linkage  D.K.  Other (Explain) \_\_\_\_\_
4. Perform stall test to check engine performance and for any sign of transmission slippage.  Performed.  
 After each stall test move selector lever to neutral with engine running at 1000 RPM to cool the transmission.  
 Caution: Release throttle immediately if slippage is indicated.

### STALL SPEED DATA

Selector Lever Position	Specified Engine RPM	Record Actual Engine RPM	DIAGNOSIS	
			Above Specified Engine RPM	Below Specified Engine RPM
R			1. Transmission slippage 2. Clutches or bands not holding	1. Poor engine performance, such as need for tune-up 2. Converter one way clutch slipping or improperly installed
D				
2				
1				

**Note:** Stall test with transmission at operating temperature. **DO NOT** hold throttle open over five seconds during tests.

5. Drive the car in each range, and through all shifts, including forced downshifts, observing any irregularities of transmission performance.

#### 6. Shift Test

Throttle Opening	Range	Shift	Shift Points (MPH)	
			Record Actual	Record Spec.
Minimum (Above 18" Vacuum)	D	1-2	---	---
	D	2-3	---	---
	D	3-1	---	---
To Detent (Torque Demand)	D	2-1	---	---
	D	1-2	---	---
	D	2-3	---	---
Thru Detent (WOT)	D	3-2	---	---
	D	1-2	---	---
	D	2-3	---	---
	D	3-2	---	---
	D	2-1 or 3-1	---	---

#### 7. Control Pressure Test - Transmission fluid must be normal operating temperatures.

Engine RPM	Manifold Vacuum Ins. Hg	Throttle	Range	PSI	
				Record Actual	Record Spec.
Idle	Above 18	Closed	P	---	---
			N	---	---
			D	---	---
			2	---	---
			1	---	---
As Req.	10	As Req.	D,2,1	---	---
As Req.	1	As Req.	D	---	---
			2	---	---
			1	---	---
			R	---	---

**NOTE:** After road test you should know the following items:

- CONTROL PRESSURE - Does the transmission have the CORRECT CONTROL PRESSURE? YES  NO
- CONTROL VALVES - Beyond the manual valve are all the CONTROL VALVES FUNCTIONING? YES  NO
- HYDRAULIC CIRCUITS - If the first two items check out good, then check the transmission's internal hydraulic circuits that are beyond the VALVE BODY. These circuits must be checked during transmission disassembly.

#### 8. TORQUE CONVERTER AND OIL COOLER (Where applicable)

- Record torque converter turbine and stator end play. TURBINE \_\_\_\_\_ STATOR \_\_\_\_\_
- Was torque converter flushed with a mechanical cleaner? YES  NO
- Was oil cooler flushed with a mechanical cleaner? YES  NO

9. The problem was diagnosed to be: \_\_\_\_\_

10. If it was necessary to disassemble the transmission, record the actual problem found: \_\_\_\_\_



BUY IT NOW!

Click Here To Order



# LESSON 1

## USE OF THE AUTOMATIC TRANSMISSION DIAGNOSIS GUIDE FD-1863-AT

Diagnosing of automatic transmission problems is not as complicated as it appears if the recommended procedures are followed. The only way to be certain of simplifying diagnosis is to follow a definite, proven procedure. Taking shortcuts, or assuming that someone else has performed certain critical tests, checks or adjustments, is bound to cause you trouble.

The general order of a systematic diagnosis procedure is shown on the Automatic Transmission Diagnosis Guide FD-1863-AT shown at the left (page 2). This guide is keyed to the “road map” diagnosis charts for specific complaints, which you will encounter further along in the handbook, and also in the Diagnosis Manual.

First, though, the course will take you through the procedures required to complete the Automatic Transmission Diagnosis Guide as called for by the complaint.

For this first lesson, read through and familiarize yourself with the contents of the guide. Then answer the following question:

### Question No. 1:

**The Automatic Transmission Diagnosis Guide (FD-1863-AT) is used to cover the correction of automatic transmission complaints on:**

- A. Passenger cars only . . . turn to page 8 (bottom).**
- B. Passenger cars and light trucks . . . turn to page 10 (bottom).**



Automatic Transmission		GROUP
		<b>17</b>
<b>PART 17-01</b>	<b>PAGE</b>	<b>PART 17-03</b>
General Transmission		FMX Automatic Transmission ..... 17-03-01
Service .....	17-01-01	<b>PART 17-04</b>
<b>PART 17-02</b>		C6 Automatic Transmission ..... 17-04-01
C4 Automatic and C4S		
Semi-Automatic Transmission .....	17-02-01	

**FIGURE 1 — CUTOUT OF AUTOMATIC TRANSMISSION SERVICE INDEX**

### **SAMPLE Answer B:**

Right! As Figure A shows and as the lesson tells you, the C4 and C6 transmissions have basically identical gear trains. Also, the hydraulic controls are very similar. The FMX uses an entirely different gear train and control system.

page 3 now and begin the course with Lesson 1.



**BUY IT NOW!**

**Click Here To Order**

