

2004

Worshop Manual



Official
Licensed
Product

License #84356800

*** DEMO / SAMPLE ***

This DEMO contains only a few pages of the entire manual/product.

Not all Bookmarks work on the DEMO, but they do on the full version.

Features:

- Searchable text
- Printable pages
- Bookmarked for easy navigation
- High Resolution images
- Zoom to see exact details
- Money back Guarantee
- Available on USB and eBook download

[Buy Now](#)



Video - Click to Watch

** Watch Video **
explains how to
purchase and
access your eBook



BUY IT NOW!

[Click Here To Order](#)



F-150

Copyright © 2025, Forel Publishing Company, LLC, Woodbridge, Virginia

All Rights Reserved. No part of this book may be used or reproduced in any manner whatsoever without written permission of Forel Publishing Company, LLC. For information write to Forel Publishing Company, LLC, Woodbridge, VA 22192

2004 Ford F-150 Truck Workshop Manual

EAN: 978-1-60371-493-8

ISBN: 1-60371-493-6

Forel Publishing Company, LLC
Woodbridge, VA 22192
Email: sales@ForelPublishing.com
<https://www.ForelPublishing.com>



License #84356800

This publication contains material that is reproduced and distributed under a license from Ford Motor Company. No further reproduction or distribution of the Ford Motor Company material is allowed without the express written permission of Ford Motor Company.

Note from the Publisher

This product was created from the original Ford Motor Company's publication. Every effort has been made to use the original scanned images, however, due to the condition of the material; some pages have been modified to remove imperfections.

Disclaimer

Although every effort was made to ensure the accuracy of this book, no representations or warranties of any kind are made concerning the accuracy, completeness or suitability of the information, either expressed or implied. As a result, the information contained within this book should be used as general information only. The author and Forel Publishing Company, LLC shall have neither liability nor responsibility to any person or entity with respect to any loss or damage caused, or alleged to be caused, directly or indirectly by the information contained in this book. Further, the publisher and author are not engaged in rendering legal or other professional services. If legal, mechanical, electrical, or other expert assistance is required, the services of a competent professional should be sought.

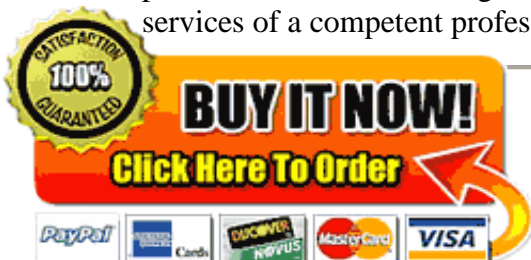

2004 F150

TABLE OF CONTENTS

INTRODUCTION

GENERAL INFORMATION

SERVICE INFORMATION

General Information	100-00
Maintenance Schedule	100-03
Noise, Vibration and Harshness	100-04

CHASSIS

SUSPENSION

Suspension System	204-00
-------------------------	--------

DRIVELINE

Driveline System	205-00
------------------------	--------

BRAKE SYSTEM

Brake System	206-00
Anti-Lock Control	206-09

STEERING SYSTEM

Steering System	211-00
-----------------------	--------

POWERTRAIN

ENGINE

Engine System — General Information	303-00
Engine — 4.6L (2V)	303-01A
Engine — 5.4L (3V)	303-01B
Engine Cooling	303-03
Intake Air, Fuel Charging, Starting and Engine Electronics — 4.6L (2V)	303-04A
Intake Air, Fuel Charging, Starting and Engine Electronics — 5.4L (3V)	303-04B

AUTOMATIC TRANSMISSION

Automatic Transmission — 4R70E/4R75E	307-01
--	--------

FOUR-WHEEL DRIVE SYSTEMS

Four-Wheel Drive Systems	308-07
--------------------------------	--------

EXHAUST SYSTEM

Exhaust System	309-00
----------------------	--------

FUEL SYSTEM

Fuel System	310-00
Speed Control	310-03

ELECTRICAL

CLIMATE CONTROL SYSTEM

Climate Control System	412-00
------------------------------	--------

INSTRUMENTATION AND WARNING SYSTEMS

Information, Gauges and Warning Devices	413-00
---	--------

BATTERY AND CHARGING SYSTEM

Battery and Charging System	414-00
-----------------------------------	--------

AUDIO SYSTEMS

Entertainment System	415-00
----------------------------	--------

LIGHTING

Exterior Lighting	417-01
Interior Lighting	417-02

ELECTRICAL DISTRIBUTION

Module Communications Network	418-00
-------------------------------------	--------

ELECTRONIC FEATURE GROUP

Anti-Theft	419-01
Electronic Features	419-02

BODY AND PAINT

BODY

Body System — Exterior	501-00
Body System — Interior	501-01
Seating	501-10
Handles, Locks, Latches and Entry Systems	501-14
Safety Belt System	501-20A
Supplemental Restraint System	501-20B

FRAME AND MOUNTING

Frame and Body Mounting	502-00
-------------------------------	--------

INDEX

NOTE: The descriptions and specifications contained in this manual were in effect at the time this manual was approved for printing. Ford Motor Company reserves the right to discontinue models at any time, or change specifications or design without notice and without incurring any obligation.

PUBLICATIONS ORDERING INFORMATION

To obtain information about ordering additional copies of this publication or to order any other Ford or Lincoln/Mercury publications, call 1-800-566-6666. Available publications include workshop manuals, wiring diagrams, PC/ED Manuals and Owner Guides.

Form by writing to: Ford Publications, care of Helm Inc., P.O. Box 07150, Detroit, MI 48207.

electronic or mechanical, including photocopying, recording, or by any information storage and not permitted without written authorization from Ford Motor Company.



BUY IT NOW!

Click Here To Order









INTRODUCTION

NOTE: The descriptions and specifications contained in this manual were in effect at the time this manual was approved for printing. Ford Motor Company reserves the right to discontinue models at any time, or change specifications or design without notice and without incurring any obligation.

IMPORTANT SAFETY NOTICE

Appropriate service methods and procedures are essential for the safe, reliable operation of all motor vehicles as well as the personal safety of the individual doing the work. This manual provides general directions for performing service with tested, effective techniques. Following them will help assure reliability.

There are numerous variations in procedure, techniques, tools and parts for servicing vehicles, as well as in the skill of the individual doing the work. This manual cannot possibly anticipate all such variations and provide advice or cautions as to each. Accordingly, anyone who departs from the instructions provided in this manual must first establish that he compromises neither his personal safety nor the vehicle integrity by his choice of methods, tools or parts.

NOTES, CAUTIONS, AND WARNINGS

As you read through the procedures, you will come across **NOTES**, **CAUTIONS**, and **WARNINGS**. Each one is there for a specific purpose. **NOTES** give you added information that will help you to perform a particular procedure. **CAUTIONS** are given to prevent you from making an error that could damage the vehicle. **WARNINGS** remind you to be especially careful in those areas where carelessness can cause you personal injury. The following list contains some general **WARNINGS** that you should follow when you work on a vehicle.

- **ALWAYS WEAR SAFETY GLASSES FOR EYE PROTECTION.**
- **USE SAFETY STANDS WHENEVER A PROCEDURE REQUIRES YOU TO BE UNDER THE VEHICLE.**
- **MAKE SURE THAT THE IGNITION SWITCH IS ALWAYS IN THE OFF POSITION, UNLESS OTHERWISE REQUIRED BY THE PROCEDURE.**
- **SET THE PARKING BRAKE WHEN WORKING ON THE VEHICLE. IF YOU HAVE AN AUTOMATIC TRANSMISSION, SET IN PARK UNLESS INSTRUCTED OTHERWISE FOR A SPECIFIC OPERATION. IF YOU HAVE A MANUAL TRANSMISSION, IT SHOULD BE IN REVERSE (ENGINE OFF) OR NEUTRAL (ENGINE ON) UNLESS INSTRUCTED OTHERWISE FOR A SPECIFIC OPERATION. PLACE WOOD BLOCKS (4" X 4" OR LARGER) AGAINST THE FRONT AND REAR SURFACES OF THE TIRES TO HELP PREVENT THE VEHICLE FROM MOVING.**
- **OPERATE THE ENGINE ONLY IN A WELL-VENTILATED AREA TO AVOID THE DANGER OF CARBON MONOXIDE POISONING.**
- **KEEP YOURSELF AND YOUR CLOTHING AWAY FROM MOVING PARTS WHEN THE ENGINE IS RUNNING, ESPECIALLY THE DRIVE BELTS.**
- **TO PREVENT SERIOUS BURNS, AVOID CONTACT WITH HOT METAL PARTS SUCH AS THE RADIATOR, EXHAUST MANIFOLD, TAIL PIPE, THREE-WAY CATALYTIC CONVERTER AND MUFFLER.**
- **DO NOT SMOKE WHILE WORKING ON A VEHICLE.**

AVOID INJURY, ALWAYS REMOVE RINGS, WATCHES, LOOSE HANGING JEWELRY AND LOOSE CLOTHING BEFORE BEGINNING TO WORK ON A VEHICLE.

BEFORE WORKING UNDER THE HOOD, KEEP HANDS AND OTHER OBJECTS CLEAR OF



BUY IT NOW!

Click Here To Order



Manual Table of Contents

SECTION 100-00 General Information

CONTENTS	PAGE
DESCRIPTION AND OPERATION	
About This Manual.....	100-00-1
Important Safety Instructions.....	100-00-1
How To Use This Manual.....	100-00-1
Icons.....	100-00-1
Identification Codes.....	100-00-3
Jacking.....	100-00-14
Lifting.....	100-00-15

100% SATISFACTION GUARANTEED

BUY IT NOW!

Click Here To Order

PayPal American Express Discover MasterCard VISA

DESCRIPTION AND OPERATION

About This Manual

Introduction

To make it easier to locate information, we have consolidated several small sections into a single section. Those sections are:

- 204-00 — Suspension System (now includes front suspension, rear suspension and wheels and tires).
- 205-00 — Driveline System (now includes driveshaft, axle and halfshafts).
- 206-00 — Brake System (now includes front brakes, rear brakes, caliper, brake booster and parking brake).
- 211-00 — Steering System (now includes steering gear, pump, linkage, column and column switches).
- 303-01 Engine (now includes accessory drive and emission controls).
- 303-04 Intake Air, Fuel Charging and Engine Electronics (now includes intake air, fuel charging, starting system and electronic engine controls).
- 307-01 — Automatic Transmission/Transaxle (now includes cooling and external controls).
- 310-00 — Fuel System (now includes tanks, lines, pump, filter, pedal and linkage and evaporative emissions).
- 412-00 — Climate Control System (now includes air distribution, heating, air conditioning, auxiliary climate control and control components).
- 413-00 — Information, Gauge and Warning Devices (now includes illumination, cluster, horn, clock, message center, warning devices, and parking aid).
- 414-00 — Battery and Charging System (now includes battery and generator).
- 415-00 — Entertainment System (now includes all video and audio components).
- 418-00 — Module Communications Network (now includes all module diagnostics and configuration).
- 419-02 — Electronic Features (now includes remote convenience, telematics, cell phone,

- 501-00 — Body System — Exterior (now includes body panels, exterior trim, mirrors, glass, bumpers and wiper system).
- 501-01 — Body System — Interior (now includes interior trim, instrument panel and console and roof opening panel).

Important Safety Instructions

Appropriate service methods and correct repair procedures are essential for the safe, reliable operation of all motor vehicles as well as the personal safety of the individual carrying out the work.

This manual cannot possibly anticipate all such variations and provide advice or cautions as to each. Anyone who departs from the instructions provided in this manual must first establish that they compromise neither their personal safety nor the vehicle integrity by their choice of methods, tools or parts.

Warnings, Cautions and Notes

 **WARNING:** Warnings are used to indicate that failure to follow a procedure correctly can result in personal injury.

 **CAUTION:** Cautions are used to indicate that failure to follow a procedure correctly can result in damage to the vehicle or equipment being used.

NOTE: Notes are used to provide additional essential information required to carry out a complete and satisfactory repair.

As you read through this manual, you will come across WARNINGS, CAUTIONS and NOTES. A warning, caution or note is placed at the beginning of a series of steps if it applies to multiple steps. If the warning, caution or note only applies to one step, it is placed at the beginning of the specific step (after the step number).







How To Use This Manual





Icons

There are ten symbols indicating oil, grease, sealant, visual inspection, use of special service tools and removal and installation details. These symbols show the points of inspecting, applying or using such materials during service.



DESCRIPTION AND OPERATION (Continued)

Symbol	Meaning
 ST2680-A	Apply petroleum jelly
 ST2681-A	Apply oil
 ST2682-A	Apply fluid
 ST2683-A	Apply grease
 ST2677-A	Apply sealant
 ST2679-A	Inspect

Symbol	Meaning
 ST2676-A	Install new
 ST2678-A	Use special tool
 ST2674-A	Installation/assembly
 ST2675-A	Removal/disassembly

General Standards

All left- and right-hand references to the vehicle are taken from a position sitting in the driver seat looking forward.

All left- and right-hand references to the engine are taken from a position at the flywheel looking toward the front camshaft pulley.

Where appropriate, instructions will be given for the use of Worldwide Diagnostic System (WDS), Ford Diagnostic System (FDS) 2000 or New Generation STAR (NGS) Tester diagnostic equipment.

BUY IT NOW!
 Click Here To Order 







DESCRIPTION AND OPERATION (Continued)

Identification Codes

Vehicle Identification Number

Vehicle Identification Number (VIN) Tag Locator

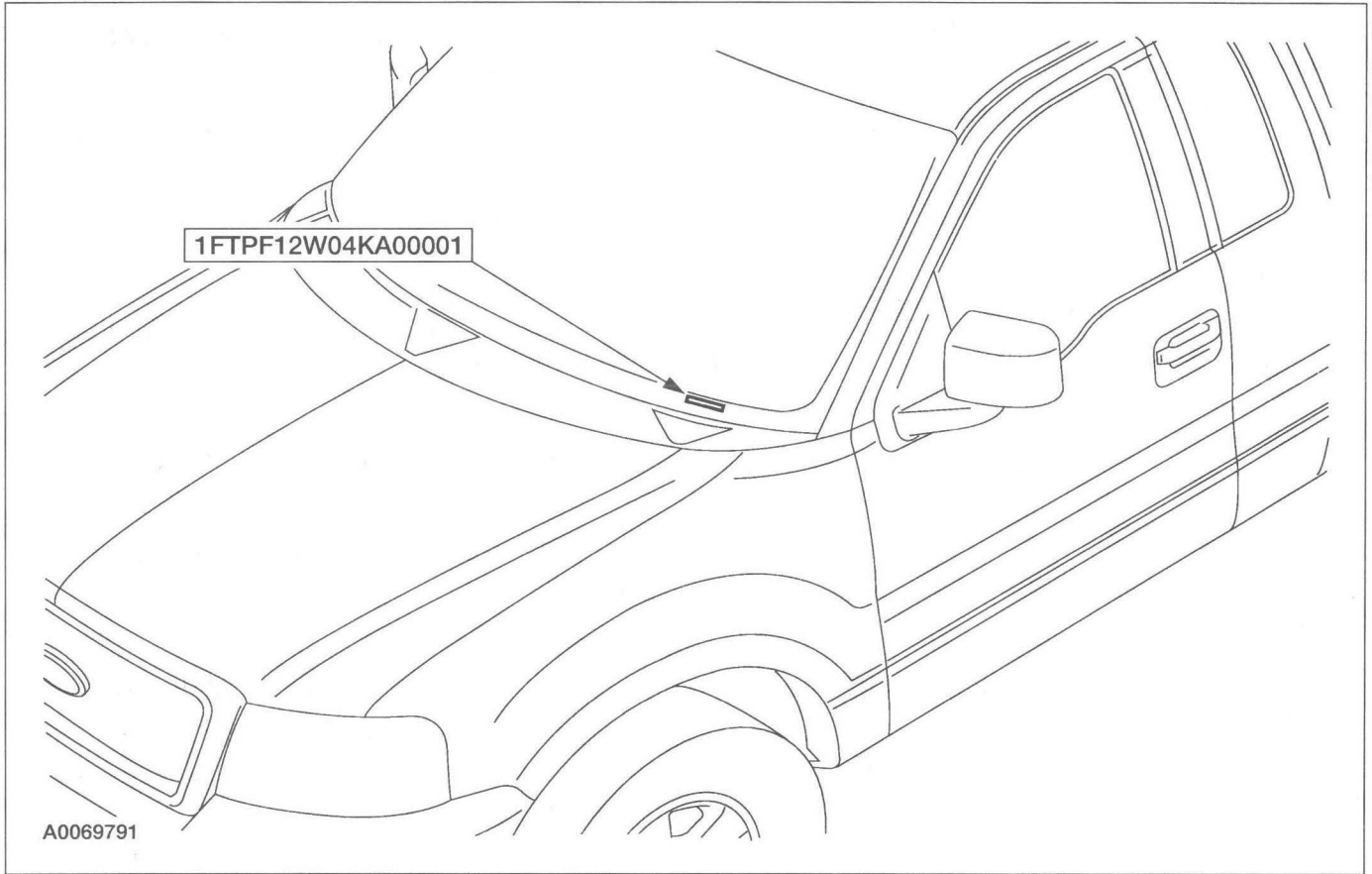

The vehicle identification number (VIN) is a seventeen-digit combination of letters and numbers. The VIN is stamped on a metal tab riveted on the instrument panel, top upper left of the dash. The VIN is also found on the vehicle certification (VC) label.

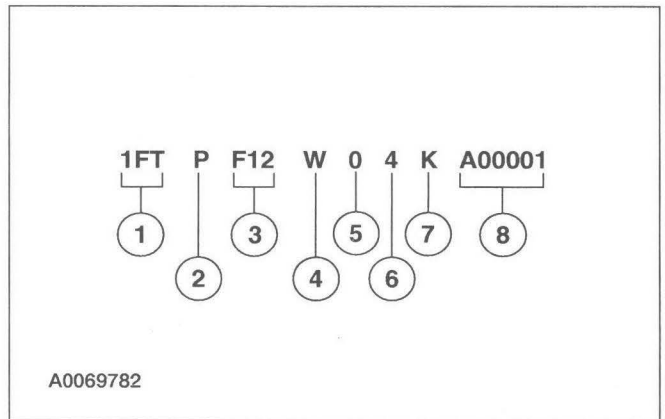

Item	Description
1	World manufacturer identifier
2	Brake type and gross vehicle weight rating (GVWR)
3	Vehicle line, series, body type
4	Engine type

100% SATISFACTION GUARANTEED

BUY IT NOW!

Click Here To Order

DESCRIPTION AND OPERATION (Continued)

Item	Description
5	Check digit
6	Model year
7	Assembly plant
8	Production sequence number

World Manufacturer Identifier

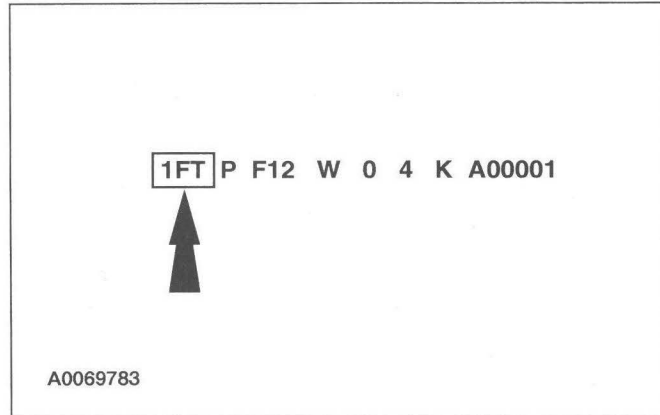

The first three vehicle identification number (VIN) positions are the world manufacturer identifier.

- 1FT — Ford Motor Company, USA, truck (completed vehicle)

Brake Type and Gross Vehicle Weight Rating (GVWR)

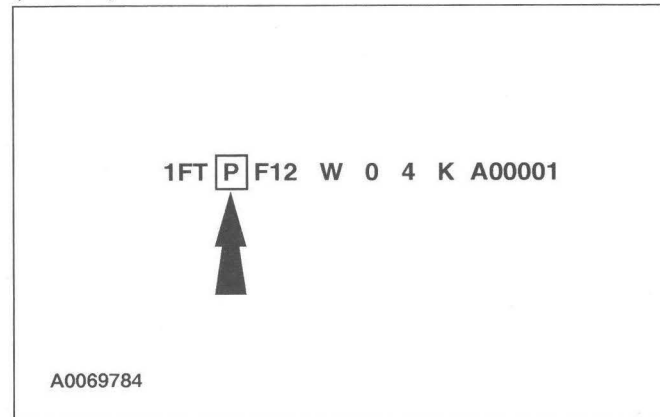

The fourth VIN position is the vehicle brake type and gross vehicle weight rating (GVWR) code, all vehicles use hydraulic brakes. This code may also identify the vehicle safety restraint system.

P — 6,001-7,000 pounds GVWR with driver and front passenger air bags

100% SATISFACTION GUARANTEED

BUY IT NOW!

Click Here To Order

Line, Series and Body Type

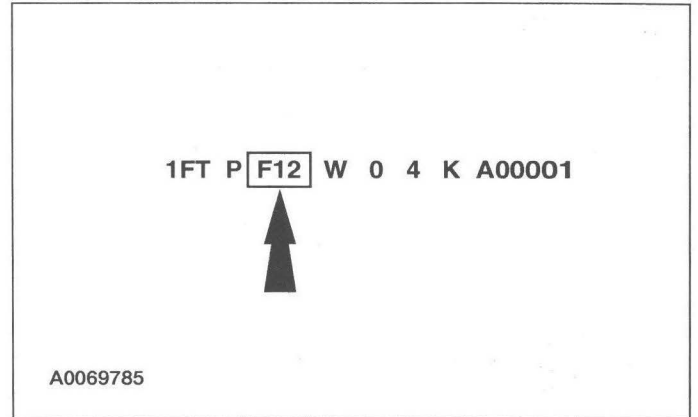

VIN positions five through seven indicate the vehicle line, series and body type.

- F02 — F-150, 4x2, regular cab, flareside
- F04 — F-150, 4x4, regular cab, flareside
- F12 — F-150, 4x2, regular cab, styleside
- F14 — F-150, 4x4, regular cab, styleside
- W12 — F-150, 4x2, Crew Cab, 5.5 ft. styleside
- W14 — F-150, 4x4, Crew Cab, 5.5 ft. styleside
- X02 — F-150, 4x2, SuperCab, 6.5 ft. flareside
- X04 — F-150, 4x4, SuperCab, 6.5 ft. flareside
- X12 — F-150, 4x2, SuperCab, 8 ft. styleside, 5.5 ft. styleside, 6.5 ft. styleside
- X14 — F-150, 4x4, SuperCab, 8 ft. styleside, 5.5 ft. styleside, 6.5 ft. styleside

Engine Type

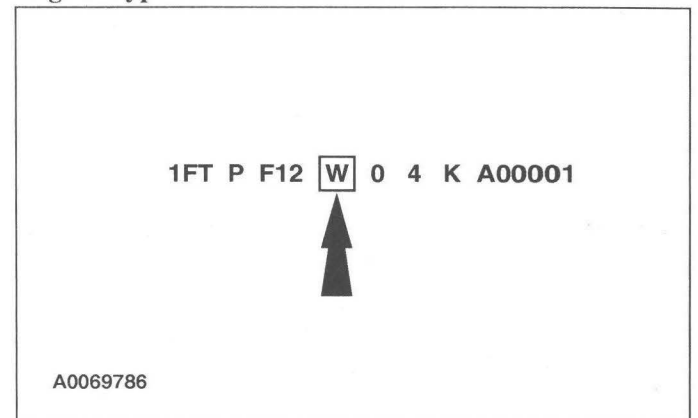

The eighth VIN position is the engine type (displacement and number of cylinders).

- 5 — 5.4L, 3-valve, SOHC, V8, EFI
- W — 4.6L, SOHC, V8, EFI

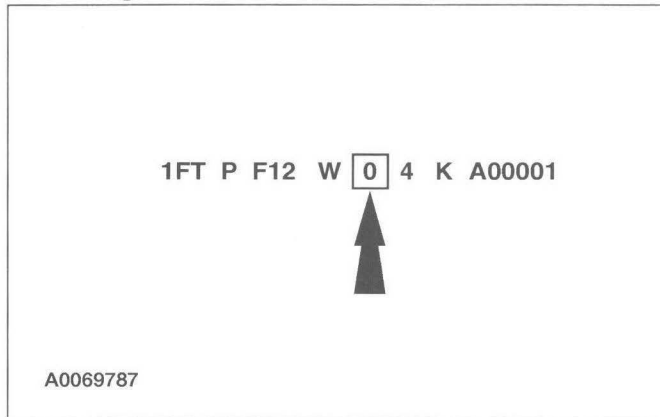
DESCRIPTION AND OPERATION (Continued)**Check Digit**

The ninth VIN position is a government assigned, computer-generated check digit.

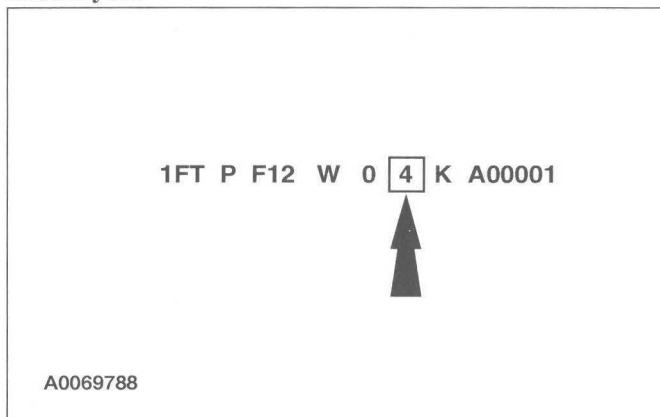
Model year

The tenth VIN position is the model year code.

- 4 — 2004

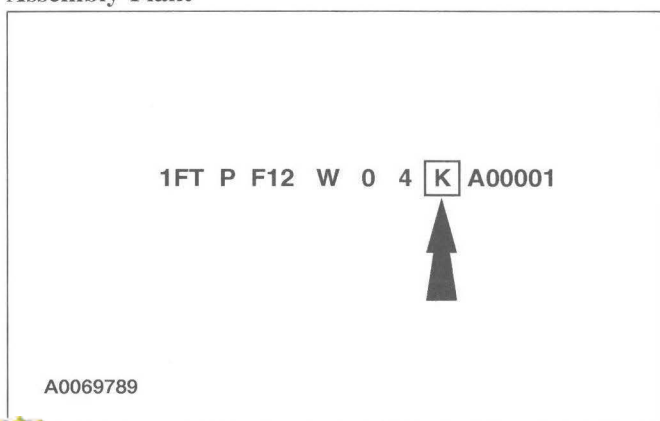
Assembly Plant

The eleventh VIN position is the assembly plant code.

- K — Kansas City — Claycomo, Missouri, USA
- N — Norfolk — Norfolk, Virginia, USA

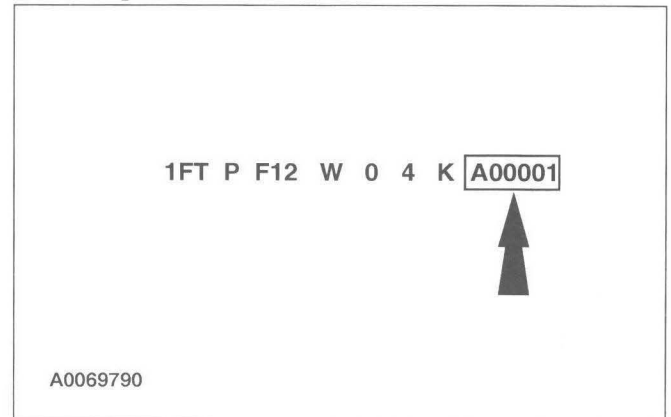
Build Sequence

VIN positions 12 through 17 are an alphanumeric code for the vehicle build sequence. This is also the vehicle serial and warranty number.

- A00001-F99999

A promotional banner with a yellow and red background. It features a circular seal on the left that says 'SATISFACTION 100% GUARANTEED'. The main text reads 'BUY IT NOW!' in large, bold, black letters, with 'Click Here To Order' in smaller yellow text below it. A red arrow points from the text to the right. At the bottom, there are logos for PayPal, American Express Cards, Discover, Novus, MasterCard, and VISA.

DESCRIPTION AND OPERATION (Continued)

Vehicle Certification (VC) Codes

Vehicle Certification (VC) Label Locator

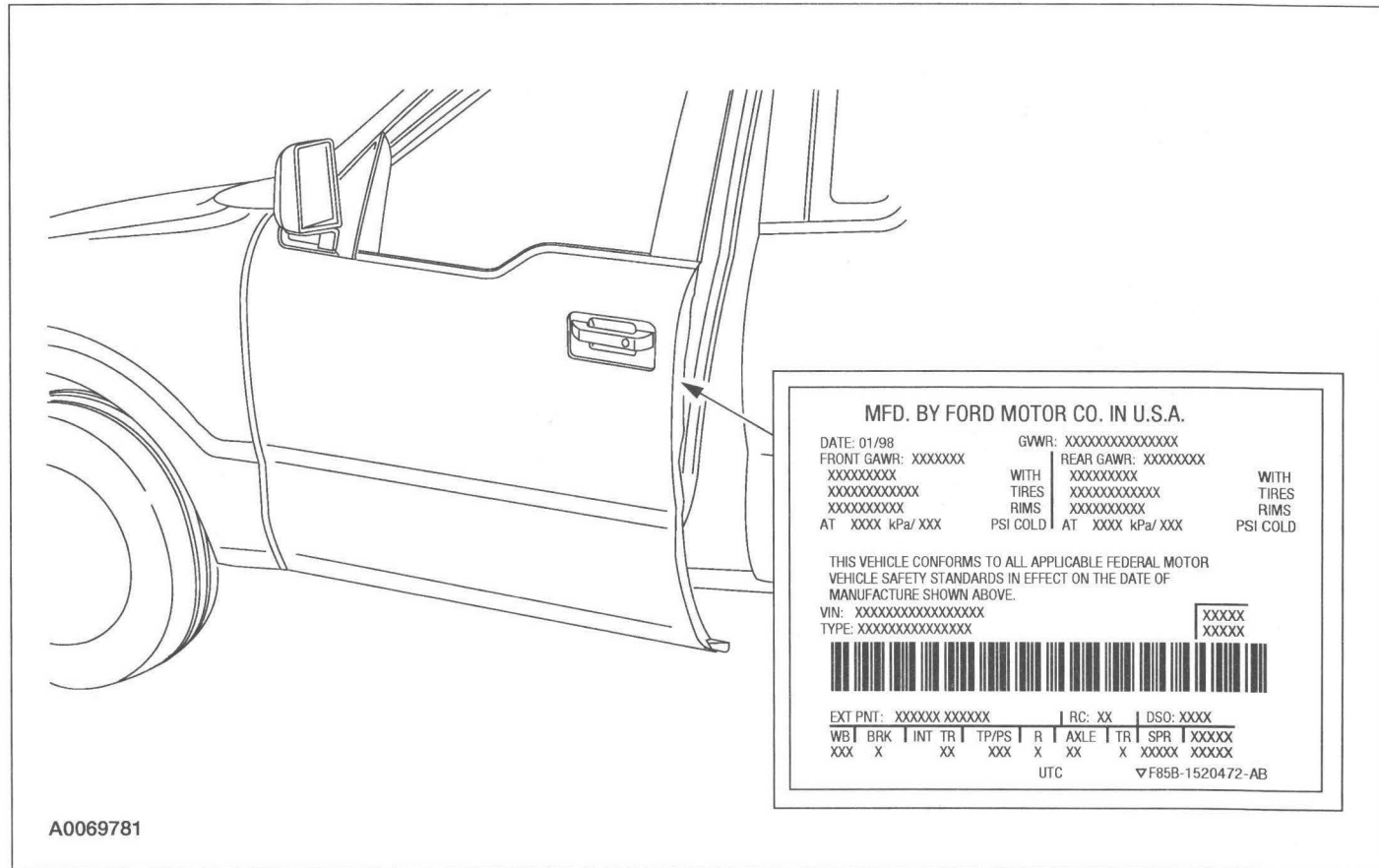

100% SATISFACTION GUARANTEED

BUY IT NOW!

Click Here To Order

DESCRIPTION AND OPERATION (Continued)

Radio Type

MFD. BY FORD MOTOR CO. IN U.S.A.

DATE: 01/98 GVWR: XXXXXXXXXXXXXXXX
 FRONT GAWR: XXXXXXXX REAR GAWR: XXXXXXXX
 XXXXXXXX WITH XXXXXXXX WITH
 XXXXXXXXXXXXXX TIRES XXXXXXXXXXXXXX TIRES
 XXXXXXXX RIMS XXXXXXXX RIMS
 AT XXXX kPa/XXX PSI COLD AT XXXX kPa/XXX PSI COLD
 XXXX

THIS VEHICLE CONFORMS TO ALL APPLICABLE FEDERAL MOTOR VEHICLE SAFETY STANDARDS IN EFFECT ON THE DATE OF MANUFACTURE SHOWN ABOVE.
 VIN: XXXXXXXXXXXXXXXX
 TYPE: XXXXXXXXXXXXXXXX



EXT PNT: XXXXXXXX XXXXXXXX | RC: XX | DSO: XXXX
 WB | BRK | INT | TR | TP/PS | R | AXLE | TR | SPR | XXXXX
 XXX X XX XXX X XX X XXXXX XXXXX
 UTC ▼ F85B-1520472-AB

A0018022

Axle Type

MFD. BY FORD MOTOR CO. IN U.S.A.

DATE: 01/98 GVWR: XXXXXXXXXXXXXXXX
 FRONT GAWR: XXXXXXXX REAR GAWR: XXXXXXXX
 XXXXXXXX WITH XXXXXXXX WITH
 XXXXXXXXXXXXXX TIRES XXXXXXXXXXXXXX TIRES
 XXXXXXXX RIMS XXXXXXXX RIMS
 AT XXXX kPa/XXX PSI COLD AT XXXX kPa/XXX PSI COLD
 XXXX

THIS VEHICLE CONFORMS TO ALL APPLICABLE FEDERAL MOTOR VEHICLE SAFETY STANDARDS IN EFFECT ON THE DATE OF MANUFACTURE SHOWN ABOVE.
 VIN: XXXXXXXXXXXXXXXX
 TYPE: XXXXXXXXXXXXXXXX



EXT PNT: XXXXXXXX XXXXXXXX | RC: XX | DSO: XXXX
 WB | BRK | INT | TR | TP/PS | R | AXLE | TR | SPR | XXXXX
 XXX X XX XXX X XX X XXXXX XXXXX
 UTC ▼ F85B-1520472-AB

A0018023

- 1 — AM/FM stereo with in-dash six-disc compact disc (CD) changer and clock
- 5 — Premium electronic AM/FM stereo with compact disc (CD) player
- 7 — AM/FM stereo clock, electronic
- K — Premium electronic AM/FM (dual media) stereo with compact disc (CD) player, cassette and clock
- T — Premium electronic AM/FM stereo with compact disc (CD) changer and clock

- 19 — 3.55 non-limited slip
- 25 — 4.10 non-limited slip
- 26 — 3.73 non-limited slip
- 27 — 3.31 non-limited slip
- B5 — 4.10 limited slip
- B6 — 3.73 limited slip
- H9 — 3.55 limited slip



BUY IT NOW!
 Click Here To Order



DESCRIPTION AND OPERATION (Continued)

Protocol 2

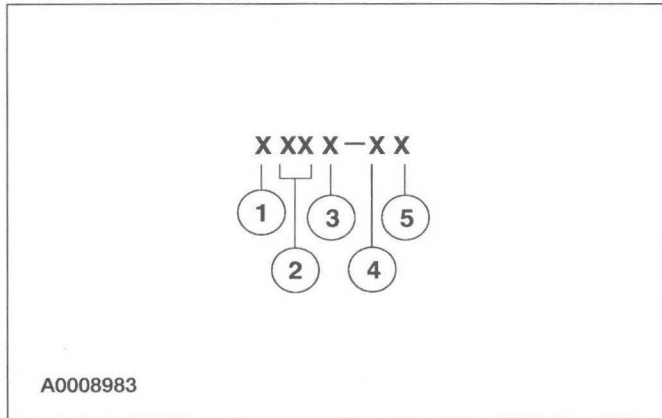

Item	Description
1	Model year (model year in which calibration strategy was first introduced)
2	Engine code
3	Transmission code
4	Emission standard (designates the specific country emission standard)
5	Design level (design level assigned to the engine)

Protocol 3

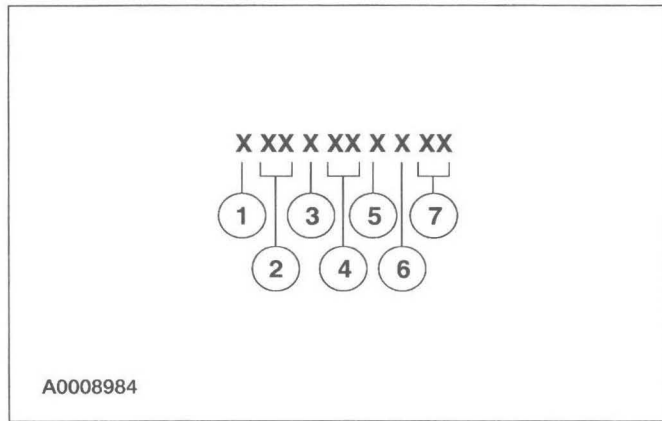

Item	Description
1	Model year (model year in which calibration strategy was first introduced)
2	Vehicle code
3	Transmission code
4	Unique calibration (designates different hardware to similar vehicles). Example:

Item	Description
5	Fleet code (describes fleet to which the vehicle belongs). Example: 6 — evaporative emissions
6	Certification region (lead region where multiple regions are included in one calibration). Example: A — U.S. federal
7	Revision level (will advance as revisions occur). Not printed on label

Protocol 3

The following offers a more detailed explanation of the coding strategy used in Protocol 3.

Model Year

- 1 — 2001
- 2 — 2002
- 3 — 2003
- 4 — 2004

Vehicle Line

- F6 — F-150

Transmission

- 1 — Automatic transmission

Unique Calibration

The Emissions/CAFE/CO2 Compliance Department is responsible for assigning these calibration numbers. Unique calibration identifications are assigned to cover similar vehicles to differentiate tires, drive configurations, final drive ratios and other calibration-significant factors.

These two characters are chosen by the analyst to provide identifiable information unique to each calibration. For example, using the number 2 to denote a two-valve engine versus using the number 4 to denote a four-valve engine, offers an easily identifiable difference.

Fleet Code

- 1 — HDGE/Dyno
- 2 — Fast AMA, U.S.
- 3 — ADP, U.S.
- 4 — Not assigned
- 5 — Not assigned
- 6 — Evaporative emissions

DESCRIPTION AND OPERATION (Continued)

- 7 — MACCA
- 8 — On-board diagnostics (OBD)
- 9 — Not assigned

Certification Region

- 5 — U.S. fifty states
- A — U.S. federal, including altitude, may include Canada and/or Mexico
- B — U.S. California, includes U.S. green states
- C — Canada
- D — China
- E — European Community (Austria, Belgium, Denmark, Finland, France, Germany, Greece, Ireland, Italy, Luxembourg, Netherlands, Portugal, Spain, Sweden, United Kingdom)
- F — Extended European Community (E plus Croatia, Czech Republic, Estonia, Hungary, Norway, Poland, Romania, Russian Federation, Slovakia, Slovenia, Switzerland, Yugoslavia)
- G — Gulf Cooperative Council (Bahrain, Kuwait, Oman, Qatar, Saudi Arabia, UAE)
- H — Hong Kong
- J — Japan
- K — Korea
- L — Malaysia
- M — Mexico
- N — New Zealand
- P — Australia
- Q — South America (Brazil)
- S — Singapore
- T — Taiwan
- V — Vietnam
- X — Rest of World (ROW)
- Y — Military
- Z — Israel

Revision Level (not printed on label)

- 91-99 — Hardware calibration levels
- 01-04 — Preliminary levels
- 00 — Job 1 production (initial calibration)

- 05-09 — Pre-job 1 revisions to calibrations
- 10-89 — Post-job 1 revisions to calibrations
- 0B — Durability test level
- BD — On-board diagnostics (OBD) intermediate level (pre-05)

Jacking

⚠ WARNING: Do not run the engine when jacking the vehicle. The wheels contacting the ground could cause the vehicle to move.

⚠ WARNING: Make sure to properly locate jack stands under the frame to prevent the vehicle from falling.

⚠ WARNING: When one of the rear wheels is off the ground, the transmission alone will not prevent the vehicle from moving or slipping off the jack, even if the transmission is in P (park) (automatic transmission) or reverse (manual transmission).

⚠ CAUTION: Wheel chocks should be used to prevent the vehicle from rolling and falling off the jack.

⚠ CAUTION: Position the jack to avoid contact with the fuel tank.

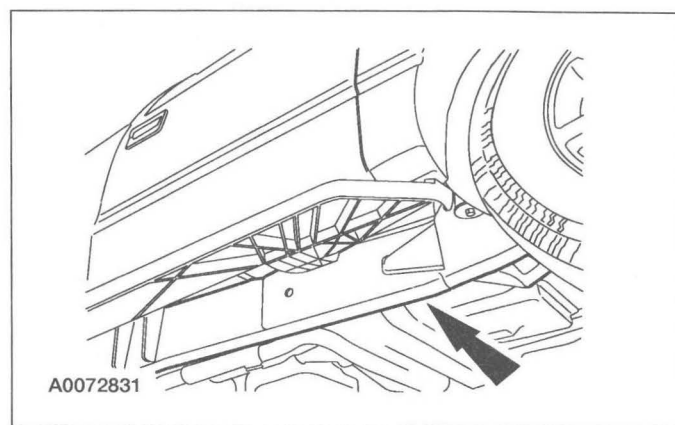
Jacking Points — Front

The jacking point is a flat portion on the frame, located behind the front tire and wheel assembly.



BUY IT NOW!

Click Here To Order



DESCRIPTION AND OPERATION (Continued)

Jacking Points — Rear

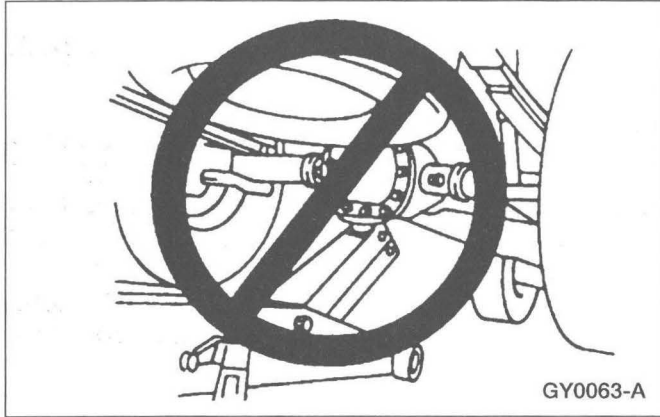

⚠ **CAUTION:** Do not use the differential housing as a lift point. Leaks or damage to the rear axle cover and adjoining differential housing surface may occur if a floor jack or any lifting device is allowed to contact the cover at any point where the cover joins the housing.

The rear jacking points are located on the rear axle.

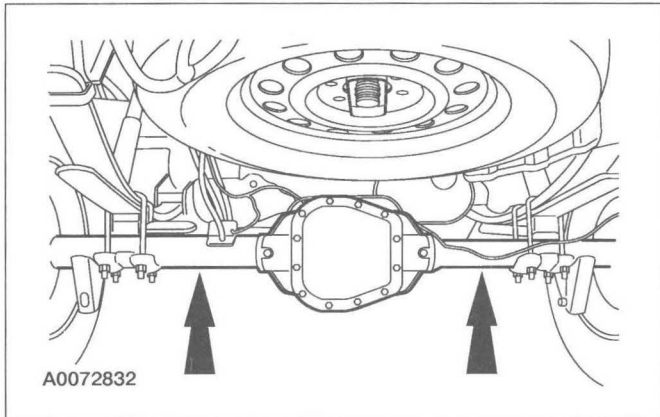

Lifting

Lifting Points

⚠ **CAUTION:** Damage to the suspension, exhaust or steering linkage components may occur if care is not exercised when positioning the hoist adapters prior to lifting the vehicle.

⚠ **CAUTION:** Position the hoist adapters to avoid contact with the fuel tank.

The following offers general guidelines for vehicle lifting. Additionally, hoist manufacturers offer their own operating precautions. Be sure to read and understand operating instructions for the lifting equipment before use.

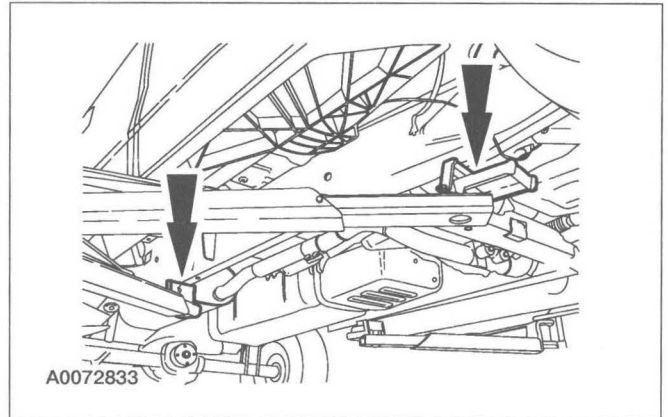

NOTE: Right side is shown, left side is similar. Position the hoist directly under the frame rails.



BUY IT NOW!

Click Here To Order



Manual Table of Contents

SECTION 100-03 Maintenance Schedule

CONTENTS	PAGE
DESCRIPTION AND OPERATION	
Maintenance Schedule — Vehicles with Gasoline Engines	100-03-1
General Maintenance Information	100-03-1
Special Operating Condition Requirements	100-03-1
Checks and Services	100-03-2
Multi-Point Inspection	100-03-2
Normal Schedule	100-03-3
Exceptions To Normal Schedule	100-03-8

SATISFACTION 100% GUARANTEED

BUY IT NOW!

Click Here To Order

PayPal Discover MasterCard VISA

DESCRIPTION AND OPERATION

Maintenance Schedule — Vehicles with Gasoline Engines

The maintenance schedule is designed to protect against major repairs resulting from neglect or inadequate maintenance and to prolong the life of the vehicle.

General Maintenance Information

NOTE: This is a generic maintenance schedule for all Ford, Lincoln and Mercury vehicles. There may be items listed that do not apply to all vehicles.

The Normal Schedule applies to operation of the vehicle under typical, everyday driving conditions. The maintenance frequency in this schedule typifies what the vast majority of vehicles will require. The listed services should be carried out at specified mileage intervals. There are, however, additional services required that only the noted vehicles require.

If the vehicle is operated in one or more of the following special operating conditions, those additional services will be required. The special operating conditions are:

- towing or carrying heavy loads.
- extensive idling and/or driving at low speeds for long distances.
- driving in dusty conditions.
- off-road operation.

There are also exceptions to the Normal Operating Schedule which will require more frequent maintenance for some components. Those exceptions are:

- natural gas and propane vehicles — fuel tank intervals.
- normal vehicle axle — maintenance and lubrication.
- police and taxi vehicles — maintenance and lubrication.
- engine oil and Premium Gold coolant — time and mileage-based interval.

Special Operating Condition Requirements

When towing a trailer or using a camper or car-top carrier:

- Change engine oil and install a new oil filter every 4,800 km (3,000 miles), 3 months or 200 hours of engine operation (whichever occurs first).
- Change transfer case fluid every 96,000 km (60,000 miles).
- Change automatic transmission fluid, lubricate 4x2 wheel bearings, install new grease seals and adjust bearings every 48,000 km (30,000 miles). If equipped, change the in-line service installed transmission fluid filter.
- Change manual transmission fluid as required.
- Inspect and lubricate U-joints and halfshafts as required.

During extensive idling and/or low speed driving for long distances, as in heavy commercial use such as delivery, taxi, patrol car or livery:

- Change engine oil and install a new oil filter every 4,800 km (3,000 miles), 3 months or 200 hours of engine operation (whichever occurs first).
- Lube front lower control arm and steering linkage ball joints with zerk fittings (if equipped) every 4,800 km (3,000 miles) or 3 months.
- Inspect brake system and check battery electrolyte level (Patrol cars) every 8,000 km (5,000 miles).
- Install a new fuel filter every 24,000 km (15,000 miles).
- Change automatic transmission fluid, lubricate 4x2 wheel bearings, install new grease seals and adjust bearings every 48,000 km (30,000 miles). If equipped, change the in-line service installed transmission fluid filter.
- Install new spark plugs and change transfer case fluid every 96,000 km (60,000 miles).
- Install a new cabin air filter as required.

When operating in dusty conditions such as unpaved or dusty roads:

- Change engine oil and install a new oil filter every 4,800 km (3,000 miles) or 3 months.
- Install a new fuel filter every 24,000 km (15,000 miles).



DESCRIPTION AND OPERATION (Continued)

- Change automatic transmission fluid, check air filter minder and install a new filter as required (Focus PZEV engine only) every 48,000 km (30,000 miles). If equipped, change the in-line service installed transmission fluid filter.
- Change transfer case fluid every 96,000 km (60,000 miles).
- Install a new engine air filter as required.
- Install a new cabin air filter as required.

When operating in off-road conditions:

- Change automatic transmission fluid every 48,000 km (30,000 miles). If equipped, change the in-line service installed transmission fluid filter.
- Change transfer case fluid every 96,000 km (60,000 miles).
- Install a new cabin air filter as required.
- Inspect and lubricate U-joints and halfshafts.
- Inspect and lubricate steering linkage ball joints with zerk fittings.

Checks and Services

Certain basic maintenance checks and inspections should be carried out at specified intervals. Any recognized adverse condition should be corrected as soon as possible.

Multi-Point Inspection

The following inspections are recommended at every service interval:

- Check and top off brake, coolant, manual and automatic power steering and window washer fluids.
- Inspect tires for wear and correct air pressure, including the spare.
- Check exhaust system for leaks, damage, loose parts and foreign material.
- Check battery performance.
- Check operation of horn, exterior lamps, turn signals and hazard warning lights.
- Check radiator, coolers, heater and air conditioning hoses.

Inspect windshield wiper spray and wiper operation.

ps and pitting.

- Inspect halfshaft dust boots.
- Check shocks, struts and other suspension components for leaks and damage.

In-Line, Service-Installed Transmission Fluid Filter

Some vehicles may be equipped with an in-line, service-installed transmission fluid filter. This filter is installed in the transmission fluid cooler return line. If equipped, install a new in-line filter during transmission fluid change intervals.

Maximum Oil Change Interval (Normal Schedule)

- 8,000 km (5,000 miles) or 6 months (whichever occurs first).

Maximum Oil Change Interval (Special Operating Conditions)

- 4,800 km (3,000 miles), 3 months or 200 hours of engine operation (whichever occurs first).

Monthly Checks

Check each of the following items every month:

- All interior and exterior lights.
- Tires for wear and correct air pressure.
- Engine oil fluid level.
- Windshield washer solvent fluid level.
- Spare tire air pressure.

Six Month Checks

Check each of the following items at least every six months:

- Lap/shoulder belts and seat latches for wear and function.
- Power steering fluid level.
- Parking brake for correct operation.
- Safety warning lamps (brake, ABS, air bag, safety belt) for correct operation.
- Coolant system fluid level and correct strength.
- Battery connections. Clean if necessary.
- Clutch fluid level, if equipped.
- Windshield washer spray, wiper operation, clean all wiper blades.
- Lubricate all hinges, latches and outside locks. Inspect for correct operation.



BUY IT NOW!

Click Here To Order



DESCRIPTION AND OPERATION (Continued)

- Lubricate door rubber weatherstrips. Inspect for excessive wear.
- Clean body and door drain holes. Inspect for clogs and obstructions.
- Lubricate upper and lower sliding door tracks, if equipped.
- Clean sliding door contact switches, if equipped.

Special Checks (Mustang Only)

Carry out the following check every 8,000 km (5,000 miles):

- Adjust clutch by lifting pedal (manual transmission, as described in owner guide).

Normal Schedule

NOTE: Rotate tires and inspect for wear at 5,000 miles, 15,000 miles and every 15,000 miles thereafter. At other 5,000-mile intervals, rotation is recommended for optimal life.

The following checks or procedures should be carried out for all cars, minivans, light trucks, sport utilities, vans, 4x4s, natural gas and propane vehicles.

8,000 Km (5,000 Miles)

- Change engine oil and install a new oil filter.
- Rotate tires and inspect for wear.
- Multi-point inspection recommended.

16,000 Km (10,000 Miles)

- Change engine oil and install a new oil filter.
- Inspect tires for wear. Rotation recommended for optimal tire life.
- Multi-point inspection recommended.

24,000 Km (15,000 Miles)

- Change engine oil and install a new oil filter.
- If equipped, inspect automatic transmission fluid level with dipstick.
- Inspect brake pads, shoes, rotors, drums, brake lines, hoses and parking brake system.
- Inspect wheel ends for end play and noise.
- Inspect engine cooling system and hoses.

- Rotate tires and inspect for wear.
- If equipped, install a new cabin air filter.
- Multi-point inspection recommended.

ADDITIONAL INFORMATION: For light trucks, sport utilities and vans, inspect and lubricate the 4x2 ball joints. Inspect and lubricate the steering linkage if equipped with zerker fittings.

32,000 Km (20,000 Miles)

- Change engine oil and install a new oil filter.
- Inspect tires for wear. Rotation recommended for optimal tire life.
- Multi-point inspection recommended.

40,000 Km (25,000 Miles)

- Change engine oil and install a new oil filter.
- Inspect tires for wear. Rotation recommended for optimal tire life.
- Drain coalescent fuel filter bowl and install a new filter (NGV).
- Multi-point inspection recommended.

48,000 Km (30,000 Miles)

- Change engine oil and install a new oil filter.
- Inspect brake pads, shoes, rotors, drums, brake lines, hoses and parking brake system.
- Inspect wheel ends for end play and noise.
- Inspect engine cooling system and hoses.
- Inspect exhaust system and heat shields.
- Inspect steering linkage, suspension and ball joints (if equipped), halfshafts, driveshaft and U-joints.
- Rotate tires and inspect for wear.
- Install a new engine air filter (not required for PZEV Focus).
- Install a new fuel filter. (See **ADDITIONAL INFORMATION** below.)
- If equipped, install a new cabin air filter.
- Change automatic transmission/transaxle fluid on all vehicles equipped with 4F50N, 4R100 and 4F27E. Inspect automatic transmission fluid level using dipstick on all other vehicles, if equipped. Change the in-line service installed transmission fluid filter, if equipped.



BUY IT NOW!

Click Here To Order



DESCRIPTION AND OPERATION (Continued)

- If equipped, install new climate controlled seat filters (Navigator, Lincoln LS, Freestar, Monterey, Expedition and Aviator).
- Multi-point inspection recommended.

ADDITIONAL INFORMATION: For light trucks, sport utilities and vans, inspect and lubricate the 4x2 ball joints. Inspect and lubricate the steering linkage if equipped with zerk fittings. If vehicle is registered in California, the California Air Resources Board (CARB) has determined that failure to install a new fuel filter at this interval will not nullify the emission warranty or limit recall liability prior to completion of the vehicle's useful life. It is, however, recommended that maintenance checks be carried out and recorded at the indicated intervals.

Natural gas and propane vehicles also require checking the fuel tanks and installing a new filter (propane vehicles).

56,000 Km (35,000 Miles)

- Change engine oil and install a new oil filter.
- Inspect tires for wear. Rotation recommended for optimal tire life.
- Multi-point inspection recommended.

64,000 Km (40,000 Miles)

- Change engine oil and install a new oil filter.
- Inspect tires for wear. Rotation recommended for optimal tire life.
- Multi-point inspection recommended.

72,000 Km (45,000 Miles)

- Change engine oil and install a new oil filter.
- Inspect automatic transmission fluid level using dipstick, if equipped.
- Inspect brake pads, shoes, rotors, drums, brake lines, hoses and parking brake system.
- Inspect wheel ends for end play and noise.
- Inspect engine cooling system and hoses.
- Inspect steering linkage, suspension and ball joints (if equipped), halfshafts, driveshaft and U-joints.

Rotate tires and inspect for wear.

air filter.

ended.

ADDITIONAL INFORMATION: For light trucks, sport utilities and vans, inspect and lubricate the 4x2 ball joints. Inspect and lubricate the steering linkage if equipped with zerk fittings.

80,000 Km (50,000 Miles)

- Change engine oil and install a new oil filter.
- Inspect tires for wear. Rotation recommended for optimal tire life.
- Drain coalescent fuel filter bowl and install a new filter (NGV).
- Clean injectors (natural gas vehicles).
- Multi-point inspection recommended.

88,000 Km (55,000 Miles)

- Change engine oil and install a new oil filter.
- Inspect tires for wear. Rotation recommended for optimal tire life.
- Multi-point inspection recommended.

96,000 Km (60,000 Miles)

- Change engine oil and install a new oil filter.
- Inspect brake pads, shoes, rotors, drums, brake lines, hoses and parking brake system.
- Inspect wheel ends for end play and noise.
- Inspect engine cooling system and hoses.
- Inspect steering linkage, suspension and ball joints (if equipped), halfshafts, driveshaft and U-joints.
- Rotate tires and inspect for wear.
- Install a new engine air filter (not required for PZEV Focus).
- Install a new fuel filter. (See **ADDITIONAL INFORMATION** below.)
- If equipped, install a new cabin air filter.
- Change automatic transmission/transaxle fluid on all vehicles equipped with 4F50N, 4R100 and 4F27E. Inspect automatic transmission fluid level using dipstick on all other vehicles, if equipped. If equipped, change the in-line service installed transmission fluid filter.
- If equipped, install new climate controlled seat filters (Navigator, Lincoln LS, Freestar, Monterey, Expedition and Aviator).
- Multi-point inspection recommended.



BUY IT NOW!

Click Here To Order



DESCRIPTION AND OPERATION (Continued)

ADDITIONAL INFORMATION: If vehicle is registered in California, the California Air Resources Board (CARB) has determined that failure to install a new fuel filter at this interval will not nullify the emission warranty or limit recall liability prior to completion of the vehicle's useful life. It is, however, recommended that maintenance checks be carried out and recorded at the indicated intervals.

Additional checks for natural gas and propane vehicles at this interval include inspecting fuel tanks, as well as draining coalescent fuel filter bowl and installing a new filter.

104,000 Km (65,000 Miles)

- Change engine oil and install a new oil filter.
- Inspect tires for wear. Rotation recommended for optimal tire life.
- Multi-point inspection recommended.

112,000 Km (70,000 Miles)

- Change engine oil and install a new oil filter.
- Inspect tires for wear. Rotation recommended for optimal tire life.
- Multi-point inspection recommended.

120,000 Km (75,000 Miles)

- Change engine oil and install a new oil filter.
- Inspect automatic transmission fluid level using dipstick.
- Inspect brake pads, shoes, rotors, drums, brake lines, hoses and parking brake system.
- Inspect wheel ends for end play and noise.
- Inspect engine cooling system and hoses.
- Inspect steering linkage, suspension and ball joints (if equipped), halfshafts, driveshaft and U-joints.
- Rotate tires and inspect for wear.
- Install a new cabin air filter.
- Drain coalescent fuel filter bowl and install a new filter (NGV).
- Multi-point inspection recommended.

ADDITIONAL INFORMATION: For light trucks, sport utilities and vans, inspect and lubricate the 4x2 ball joints. Inspect and lubricate the steering linkage if equipped with zerk fittings.

128,000 Km (80,000 Miles)

- Change engine oil and install a new oil filter.
- Inspect tires for wear. Rotation recommended for optimal tire life.
- Multi-point inspection recommended.

136,000 Km (85,000 Miles)

- Change engine oil and install a new oil filter.
- Inspect tires for wear. Rotation recommended for optimal tire life.
- Multi-point inspection recommended.

144,000 Km (90,000 Miles)

- Change engine oil and install a new oil filter.
- Inspect brake pads, shoes, rotors, drums, brake lines, hoses and parking brake system.
- Inspect wheel ends for end play and noise.
- Inspect engine cooling system and hoses.
- Inspect exhaust system and heat shields.
- Inspect steering linkage, suspension and ball joints (if equipped), halfshafts, driveshaft and U-joints.
- Rotate tires and inspect for wear.
- Install a new engine air filter.
- Install a new fuel filter.
- If equipped, install a new cabin air filter.
- Change automatic transmission/transaxle fluid on all vehicles equipped with 4F50N, 4R100 and 4F27E. Inspect automatic transmission fluid level using dipstick on all other vehicles, if equipped. If equipped, change the in-line service installed transmission fluid filter.
- If equipped, install new climate controlled seat filters (Navigator, Lincoln LS, Freestar, Monterey, Expedition and Aviator).
- Multi-point inspection recommended.

ADDITIONAL INFORMATION: For light trucks, sport utilities and vans, inspect and lubricate the 4x2 ball joints. Inspect and lubricate the steering linkage if equipped with zerk fittings.

Additional services for natural gas and propane vehicles include inspecting fuel tanks, as well as draining coalescent fuel filter bowl and installing a new filter.



BUY IT NOW!

Click Here To Order



DESCRIPTION AND OPERATION (Continued)**152,000 Km (95,000 Miles)**

- Change engine oil and install a new oil filter.
- Inspect tires for wear. Rotation recommended for optimal tire life.
- Multi-point inspection recommended.

160,000 Km (100,000 Miles)

- Change engine oil and install a new oil filter.
- Inspect accessory drive belt(s).
- Rotate tires and inspect for wear.
- Install new spark plugs.
- Change Premium Gold coolant or change at 5 years, whichever comes first.
- Install a new PCV external on all cars and light trucks under 6,000 pounds Gross Vehicle Weight (GVW), except 5.4L 3V engine.
- Drain coalescent fuel filter bowl and install a new filter (NGV).
- Clean injectors (NGV).
- Multi-point inspection recommended.

168,000 Km (105,000 Miles)

- Change engine oil and install a new oil filter.
- Inspect automatic transmission fluid level if equipped with dipstick.
- Inspect brake pads, shoes, rotors, drums, brake lines, hoses and parking brake system.
- Inspect wheel ends for end play and noise.
- Inspect engine coolant system and hoses.
- Lubricate 4x2 ball joints and steering linkage if equipped with zerk fittings.
- Inspect steering linkage, suspension and ball joints (if equipped), halfshafts, driveshaft and U-joints.
- Rotate tires and inspect for wear.
- If equipped, install a new cabin air filter.
- Change coolant.
- Multi-point inspection recommended.

176,000 Km (110,000 Miles)

- Change engine oil and install a new oil filter.
- Inspect tires for wear. Rotation recommended for optimal tire life.
- Multi-point inspection recommended.

184,000 Km (115,000 Miles)

- Change engine oil and install a new oil filter.
- Inspect tires for wear. Rotation recommended for optimal tire life.
- Multi-point inspection recommended.

192,000 Km (120,000 Miles)

- Change engine oil and install a new oil filter.
- Inspect brake pads, shoes, rotors, drums, brake lines, hoses and parking brake system.
- Inspect wheel ends for end play and noise.
- Inspect engine cooling system and hoses.
- Inspect exhaust system and heat shields.
- Inspect steering linkage, suspension and ball joints (if equipped), halfshafts, driveshaft and U-joints.
- Rotate tires and inspect for wear.
- Install a new engine air filter (not required for PZEV Focus).
- Install a new fuel filter. (See ADDITIONAL INFORMATION below.)
- If equipped, install a new cabin air filter.
- Install a new external PCV valve on all cars and light trucks over 6,000 Gross Vehicle Weight, except 5.4L 3V engine.
- Change automatic transmission/transaxle fluid on all vehicles equipped with 4F50N, 4R100 and 4F27E. Inspect automatic transmission fluid level using dipstick on all other vehicles, if equipped. If equipped, change the in-line service installed transmission fluid filter.
- Install a new camshaft belt on all 2.0L, 4-cylinder engines (Focus and Escape).
- If equipped, install new climate controlled seat filters (Navigator, Lincoln LS, Freestar, Monterey, Expedition and Aviator).
- Multi-point inspection recommended.

ADDITIONAL INFORMATION: Additional services for natural gas and propane vehicles include inspecting fuel tanks, as well as draining coalescent fuel filter bowl and installing a new filter (propane only). Change manual transmission fluid. Install a new camshaft belt on 4 cylinder engine (2.0L Escape).



BUY IT NOW!

Click Here To Order



DESCRIPTION AND OPERATION (Continued)**200,000 Km (125,000 Miles)**

- Change engine oil and install a new oil filter.
- Inspect tires for wear. Rotation recommended for optimal tire life.
- Drain coalescent fuel filter bowl and install a new filter (NGV).
- Multi-point inspection recommended.

208,000 Km (130,000 Miles)

- Change engine oil and install a new oil filter.
- Inspect tires for wear. Rotation recommended for optimal tire life.
- Multi-point inspection recommended.

216,000 Km (135,000 Miles)

- Change engine oil and install a new oil filter.
- If equipped, inspect automatic transmission fluid level with dipstick.
- Inspect brake pads, shoes, rotors, drums, brake lines, hoses and parking brake system.
- Inspect wheel ends for end play and noise.
- Inspect engine cooling system and hoses.
- Inspect steering linkage, suspension and ball joints (if equipped), halfshafts, driveshaft and U-joints.
- Rotate tires and inspect for wear.
- Install a new cabin air filter.
- Multi-point inspection recommended.

224,000 Km (140,000 Miles)

- Change engine oil and install a new oil filter.
- Inspect tires for wear. Rotation recommended for optimal tire life.
- Multi-point inspection recommended.

232,000 Km (145,000 Miles)

- Change engine oil and install a new oil filter.
- Inspect tires for wear. Rotation recommended for optimal tire life.
- Multi-point inspection recommended.

240,000 Km (150,000 Miles)

- Change engine oil and install a new oil filter.
- Inspect tires for wear. Rotation recommended for optimal tire life.
- Multi-point inspection recommended.
- Inspect belts and seals (if not already installed in

- Change engine oil and install a new oil filter.
- Inspect brake pads, shoes, rotors, drums, brake lines, hoses and parking brake system.
- Inspect wheel ends for end play and noise.
- Inspect engine cooling system and hoses.
- Inspect exhaust system and heat shields.
- Inspect steering linkage, suspension and ball joints (if equipped), halfshafts, driveshaft and U-joints.
- Rotate tires and inspect for wear.
- Install a new engine air filter (not required on PZEV Focus).
- Install a new fuel filter. (See ADDITIONAL INFORMATION below.)
- Lubricate 4x2 ball joints and steering linkage if equipped with zerk fittings.
- If equipped, install a new cabin air filter.
- Change Premium Gold coolant (See Exceptions To Normal Schedule).
- Change automatic transmission/transaxle fluid and filter.
- Change rear axle lubricant on all rear wheel (RWD) vehicles.
- Install a new camshaft on 4 cylinder engine (2.0L Escape).
- Install a new accessory drive belt(s) (if a new belt has not been installed within the last 100,000 miles).
- If equipped, install new climate controlled seat filters (Navigator, Lincoln LS, Freestar, Monterey, Expedition and Aviator).
- Multi-point inspection recommended.

ADDITIONAL INFORMATION: If vehicle is registered in California, the California Air Resources Board (CARB) has determined that failure to install a new fuel filter at this interval will not nullify the emission warranty or limit recall liability prior to completion of the vehicle's useful life. It is, however recommended that maintenance checks be carried out and recorded at the indicated intervals.

Additional checks for natural gas and propane vehicles include inspecting fuel tanks, as well as draining and installing a new filter.

g and seals (if
been installed in

DESCRIPTION AND OPERATION (Continued)**Exceptions To Normal Schedule****Premium Gold Coolant**

- Change Premium Gold coolant at 5 years or 160,000 km (100,000 miles) of the vehicle's life, whichever comes first.
- After the initial change, change coolant every 3 years or 80,000 km (50,000 miles) thereafter.

Natural Gas and Propane Vehicles

- Inspect NGV fuel tanks from the date of tank manufacture every 3 years.
- Inspect propane fuel tanks from vehicle build date every 5 years.
- Install new NGV fuel tanks from the date of tank manufacture every 15 years.

Normal Vehicle Axle Maintenance

Rear axles and power take off (PTO) units containing synthetic lubricant and light duty trucks equipped with Ford-design axles are lubricated for life. These lubricants are not to be checked or changed unless service is required, or if a leak is suspected, or the axle assembly has been submerged in water.

The axle and PTO should be changed anytime they have been submerged in water. Non-synthetic rear axle lubricants should be replaced every 4,800 km (3,000 miles) or three months, whichever occurs first, during extended trailer tow operation above 21°C (70°F) ambient and wide open throttle for extended periods above 45 mph.

The 3,000 mile lube change interval may be waived if the axle was filled with 75W140 synthetic gear lubricant meeting Ford specification WSL-M2C192-A, part number FITZ-19580-B or equivalent. Add four ounces of additive friction modifier C8AZ-19B546-A (EST-M2C118-A) or equivalent for complete refill of Traction-Lok rear axles.

The axle lubricant should be changed anytime an axle has been submerged in water.

Police and Taxi Vehicle Axle Maintenance

Replace rear axle lubricant every 160,000 km (100,000 miles). Rear axle lubricant change may be waived if the axle was filled with 75W140 synthetic gear lubricant meeting Ford specification WSL-M2C192-A, part number FITZ-19580-B or equivalent. Add four ounces of additive friction modifier C8AZ-19B546-A (EST-M2C118-A) or equivalent for complete refill of Traction-Lok rear axles.

The axle lubricant should be changed anytime an axle has been submerged in water.

BUY IT NOW!
Click Here To Order

PayPal American Express Discover MasterCard VISA

Manual Table of Contents

SECTION 100-04 Noise, Vibration and Harshness

CONTENTS	PAGE
DESCRIPTION AND OPERATION	
Noise, Vibration and Harshness (NVH).....	100-04-1
Acceptable Noise, Vibration and Harshness	100-04-1
Diagnostic Theory.....	100-04-1
Glossary of Terms.....	100-04-1
Tools and Techniques.....	100-04-6
DIAGNOSIS AND TESTING	
Noise, Vibration and Harshness (NVH).....	100-04-9
1: Customer Interview	100-04-13
2: Pre-Drive Check.....	100-04-13
3: Preparing for the Road Test.....	100-04-13
4: Verify the Customer Concern	100-04-13
5: Road Test.....	100-04-14
Slow Acceleration Test.....	100-04-14
Heavy Acceleration Test.....	100-04-14
Neutral Coast Down Speed Test.....	100-04-14
Downshift Speed Test	100-04-14
Steering Input Test	100-04-15
Brake Test.....	100-04-15
Road Test Over Bumps.....	100-04-15
Neutral Engine Run-Up (NERU) Test	100-04-15
Drive Engine Run-Up (DERU) Load Test	100-04-15
Engine Accessory Test.....	100-04-16
Vehicle Cold Soak Procedure	100-04-16
6: Check OASIS/TSBs/Repair History	100-04-16
7: Diagnostic Procedure.....	100-04-16
NVH Condition and Symptom Categories	100-04-17
Symptom Charts.....	100-04-18
Pinpoint Tests.....	100-04-53
Component Tests	100-04-65
GENERAL PROCEDURES	
Brake Disc Machining	100-04-71
Powertrain/Drivetrain Mount Neutralizing	100-04-72
Exhaust System Neutralizing	100-04-72
Wheel Bearing Check.....	100-04-73



DESCRIPTION AND OPERATION

Noise, Vibration and Harshness (NVH)

Noise is any undesirable sound, usually unpleasant in nature. Vibration is any motion, shaking or trembling, that can be felt or seen when an object moves back and forth or up and down. Harshness is a ride quality issue where the vehicle's response to the road transmits sharply to the customer.

Harshness normally describes a firmer than usual response from the suspension system. Noise, vibration and harshness (NVH) is a term used to describe these conditions, which result in varying degrees of dissatisfaction. Although, a certain level of NVH caused by road and environmental conditions is normal. This section is designed to aid in the diagnosis, testing and repair of NVH concerns.

Acceptable Noise, Vibration and Harshness

All internal combustion engines and drivelines produce some noise and vibration; operating in a real world environment adds noise that is not subject to control. Vibration isolators, mufflers and dampers reduce these to acceptable levels. A driver who is unfamiliar with a vehicle can think that some sounds are abnormal when actually the sounds are normal for the vehicle type. For example, Traction-Lok® differentials produce a slight noise on slow turns after extended highway driving. This is acceptable and has no detrimental effect on the locking axle function. As a technician, it is very important to be familiar with vehicle features and know how they relate to NVH concerns and their diagnosis. For example, if the vehicle has automatic overdrive, it is important to test drive the vehicle both in and out of overdrive mode.

Diagnostic Theory

The shortest route to an accurate diagnosis results from:

- system knowledge, including comparison with a known good system.
- system history, including repair history and usage patterns.
- condition history, especially any relationship to repairs or sudden change.

The diagnosis and correction of noise, vibration and harshness concerns requires:

- a road or system test to determine the exact nature of the concern.
- an analysis of the possible causes.
- testing to verify the cause.
- repairing any concerns found.
- a road test or system test to make sure the concern has been corrected or brought back to within an acceptable range.

Glossary of Terms

Acceleration-Light

An increase in speed at less than half throttle.

Acceleration-Medium

An increase in speed at half to nearly full throttle, such as 0-97 km/h (0-60 mph) in approximately 30 seconds.

Acceleration-Heavy

An increase in speed at one-half to full throttle, such as 0-97 km/h (0-60 mph) in approximately 20 seconds.

Ambient Temperature

The surrounding or prevailing temperature.

Amplitude

The quantity or amount of energy produced by a vibrating component (G force). An extreme vibration has a high amplitude. A mild vibration has a low amplitude.

Backlash

Gear teeth clearance.

Boom

Low frequency or low pitched noise often accompanied by a vibration. Also refer to Drumming.

Bound Up

An overstressed isolation (rubber) mount that transmits vibration/noise instead of absorbing it.

Brakes Applied

When the service brakes are applied with enough force to hold the vehicle against movement with the transmission in gear.

Buffet/Buffering

Strong noise fluctuations (less than 1000 Hz) caused by gusting winds. An example would be wind gusts against the side glass.

BUY IT NOW! method that divides

Click Here To Order

PayPal American Express Discover MasterCard VISA

DESCRIPTION AND OPERATION (Continued)**Buzz**

A low-pitched sound like (200-5000 Hz) that from a bee. Often a metallic or hard plastic humming sound. Also describes a high frequency (200-800 Hz) vibration. Vibration feels similar to an electric razor.

Camber

The angle of the wheel in relation to the true vertical as measured looking from the front of the vehicle. Camber is positive when the wheel angle is offset so that the top of the wheel is positioned away from the vehicle.

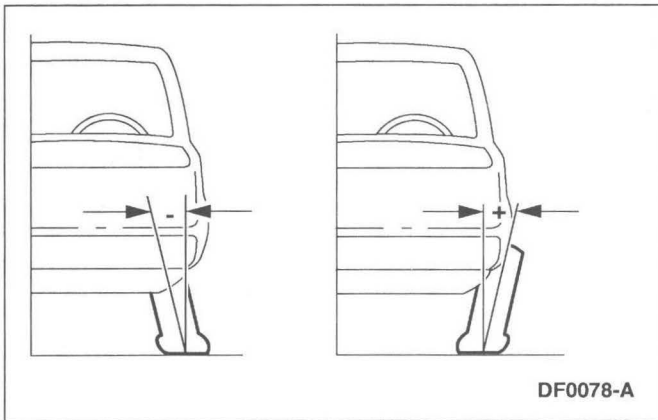
**Caster**

The angle of the steering knuckle in relation to the true vertical as measured looking from the side of the vehicle.

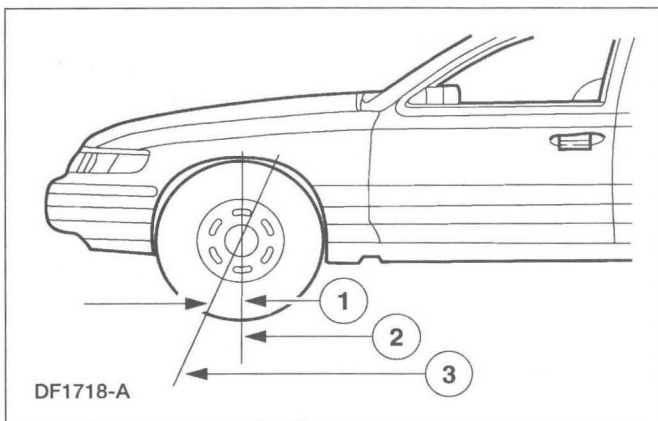

Item	Description
1	Positive caster
2	True vertical
3	Steering axis

Chatter

A pronounced series of rapidly repeating rattling or clicking sounds.

Chirp

A short-duration high-pitched noise associated with a slipping drive belt.

Chuckle

A repetitious low-pitched sound. A loud chuckle is usually described as a knock.

Click

A sharp, brief, non-resonant sound, similar to actuating a ball point pen.

Clonk

A hydraulic knocking sound. Sound occurs with air pockets in a hydraulic system. Also described as hammering.

Clunk/Driveline Clunk

A heavy or dull, short-duration, low-frequency sound. Occurs mostly on a vehicle that is accelerating or decelerating abruptly. Also described as a thunk.

Coast/Deceleration

Releasing the accelerator pedal at cruise, allowing the engine to reduce vehicle speed without applying the brakes.

Coast/Neutral Coast

Placing the transmission range selector in NEUTRAL (N) or depressing the clutch pedal while at cruise.

Constant Velocity (CV) Joint

A joint used to absorb vibrations caused by driving power being transmitted at an angle.

Controlled Rear Suspension Height

The height at which a designated vehicle element must be when driveline angle measurements are made.

Coupling Shaft

The shaft between the transfer case and the front drive axle or, in a two-piece rear driveshaft, the front section.

100% SATISFACTION GUARANTEED

BUY IT NOW!

Click Here To Order

PayPal | American Express | Discover | MasterCard | VISA

DESCRIPTION AND OPERATION (Continued)

CPS

Cycles per second. Same as hertz (Hz).

Cracks

A mid-frequency sound, related to squeak. Sound varies with temperature conditions.

Creak

A metallic squeak.

Cruise

Constant speed on level ground; neither accelerating nor decelerating.

Cycle

The process of a vibrating component going through a complete range of motion and returning to the starting point.

Decibel

A unit of measurement, referring to sound pressure level, abbreviated dB.

Drive Engine Run-Up (DERU) Test

The operation of the engine through the normal rpm range with the vehicle standing still, the brakes applied and the transmission engaged. This test is used for noise and vibration checks.

Driveline Angles

The differences of alignment between the transmission output shaft, the driveshaft, and the rear axle pinion centerline.

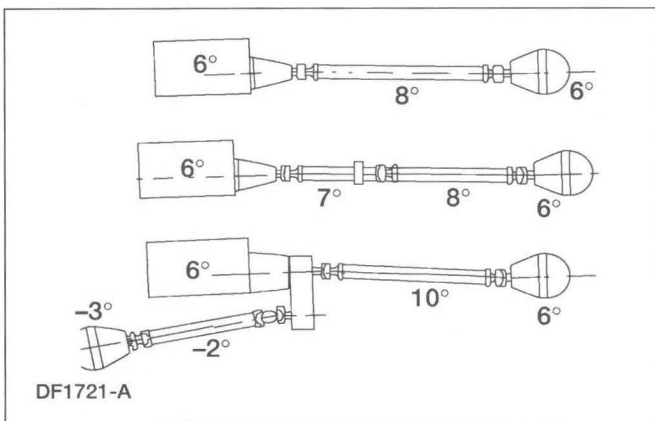

Driveshaft

The shaft that transmits power to the rear axle input shaft (pinion shaft). In a two-piece driveshaft, it is the rearmost shaft.

Drivetrain Damper

A weight attached to the engine, the transmission, the transfer case, or the axle. It is tuned by weight and placement to absorb vibration.

Drone

A low frequency (100-200 Hz) steady sound, like a freezer compressor. Also described as a moan.

Drumming

A cycling, low-frequency (20-100 Hz), rhythmic noise often accompanied by a sensation of pressure on the ear drums. Also described as a low rumble, boom, or rolling thunder.

Dynamic Balance

The equal distribution of weight on each side of the centerline, so that when the wheel and tire assembly spins, there is no tendency for the assembly to move from side-to-side (wobble). Dynamically unbalanced wheel and tire assemblies can cause wheel shimmy.

Engine Imbalance

A condition in which an engine's center mass is not concentric to the rotation center, causing excessive motion.

Engine Misfire

When combustion in one or more cylinders does not occur or occurs at the wrong time.

Engine Shake

An exaggerated engine movement or vibration that directly increases in frequency as the engine speed increases. It is caused by non-equal distribution of mass in the rotating or reciprocating components.

Flexible Coupling

A flexible joint.

Float

A drive mode on the dividing line between cruise and coast where the throttle setting matches the engine speed with the road speed.

Flutter

Mid to high (100-2000 Hz) intermittent sound due to air flow. Similar to a flag flapping in the wind.

Frequency

The rate at which a cycle occurs within a given time.

Gravelly Feel

A grinding or growl in a component, similar to the feel experienced when driving on gravel.

**SATISFACTION
100%
GUARANTEED**

BUY IT NOW!

Click Here To Order

PayPal American Express Discover MasterCard VISA

DESCRIPTION AND OPERATION (Continued)

Grind

An abrasive sound, similar to using a grinding wheel, or rubbing sand paper against wood.

Hiss

Steady high frequency (200-800 Hz) noise. Vacuum leak sound.

Hoot

A steady low frequency tone (50-500 Hz), sounds like blowing over a long neck bottle.

Howl

A mid-range frequency (200-800 Hz) noise between drumming and whine. Also described as a hum.

Hum

Mid-frequency (200-800 Hz) steady sound, like a small fan motor. Also described as a howl.

Hz

Hertz; a frequency measured in cycles per second.

Imbalance

Out of balance; heavier on one side than the other. In a rotating component, imbalance often causes vibration.

Inboard

Toward the centerline of the vehicle.

Intensity

The physical quality of sound that relates to the strength of the vibration (measured in decibels). The higher the sound's amplitude, the higher the intensity and vice versa.

Isolate

To separate the influence of one component to another.

Knock

A heavy, loud, repetitious sound, like a knock on the door.

Moan

A constant, low-frequency (100-200 Hz) tone. Also described as a hum.

Neutral Engine Run-Up (NERU) Test

The operation of the engine through the normal rpm range with the vehicle standing still and the transmission disengaged. This test is used to identify the related vibrations.

Outboard

Away from the centerline of the vehicle.

Ping

A short duration, high-frequency sound, which has a slight echo.

Pinion Shaft

The input shaft in a driving axle that is usually a part of the smaller driving or input hypoid gear of a ring and pinion gearset.

Pitch

The physical quality of sound that relates to its frequency. Pitch increases as frequency increases and vice versa.

Pumping Feel

A slow, pulsing movement.

Radial/Lateral

Radial is in the plane of rotation; lateral is at 90 degrees to the plane of rotation.

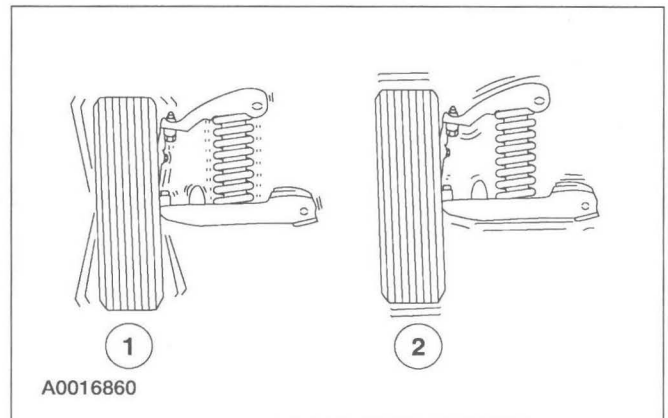

Item	Description
1	Lateral runout
2	Radial runout

Rattle

A random and momentary or short duration noise.

Ring Gear

The large, circular, driven gear in a ring and pinion gearset.

Road Test

The operation of the vehicle under conditions intended to produce the concern under investigation.

Roughness

A medium-frequency vibration. A slightly higher frequency (20 to 50 Hz) than a shake. This type of vibration is usually related to drivetrain components.

100% SATISFACTION GUARANTEED

BUY IT NOW! Used to

Click Here To Order

PayPal, American Express, Discover, MasterCard, VISA

DESCRIPTION AND OPERATION (Continued)

Runout

Lateral runout means measuring the movement or “wobble” of a wheel or tire at the sidewall. Radial runout means measuring the out-of-round at the tread surface.

Rustling

Intermittent sound of varying frequency (100-2000 Hz), sounds similar to shuffling through leaves.

Shake

A low-frequency vibration (5-20 Hz), usually with visible component movement. Usually relates to tires, wheels, brake drums or brake discs if it is vehicle speed sensitive, or engine if it is engine speed sensitive. Also referred to as a shimmy or wobble.

Shimmy

An abnormal vibration or wobbling, felt as a side-to-side motion of the steering wheel in the driveshaft rotation. Also described as waddle.

Shudder

A low-frequency vibration that is felt through the steering wheel or seat during light brake application.

Slap

A resonance from flat surfaces, such as safety belt webbing or door trim panels.

Slip Yoke/Slip Spline

The driveshaft coupling that allows length changes to occur while the suspension articulates and while the driveshaft rotates.

Squeak

A high-pitched transient sound, similar to rubbing fingers against a clean window.

Squeal

A long-duration, high-pitched noise.

Static Balance

The equal distribution of weight around the wheel. Statically unbalanced wheel and tire assemblies can cause a bouncing action called wheel tramp. This condition will eventually cause uneven tire wear.

Tap

A light, rhythmic, or intermittent hammering sound, similar to tapping a pencil on a table edge.

Tip-In Moan

A light moaning noise heard during light vehicle acceleration, usually between 40-100 km/h (25-65 mph).

TIR

The acronym for total indicated runout is TIR.

Tire Deflection

The change in tire diameter in the area where the tire contacts the ground.

Tire Flat Spots

A condition commonly caused by letting the vehicle stand while the tires cool off. This condition can be corrected by driving the vehicle until the tires are warm. Also, irregular tire wear patterns in the tire tread resulting from wheel-locked skids.

Tire Force Vibration

A tire vibration caused by variations in the construction of the tire that is noticeable when the tire rotates against the pavement. This condition can be present on perfectly round tires because of variations in the inner tire construction. This condition can occur at wheel rotation frequency or twice rotation frequency.

Transient

A noise or vibration that is momentary, a short duration.

Two-Plane Balance

Radial and lateral balance.

Vibration

Any motion, shaking or trembling, that can be felt or seen when an object moves back and forth or up and down.

Whine

A constant, high-pitched noise. Also described as a screech.

Whistle

High-pitched noise (above 500 Hz) with a very narrow frequency band. Examples of whistle noises are a turbocharger or airflow around an antenna.

Wind Noise

Any noise caused by air movement in, out or around the vehicle.

WOT

The acronym for wide open throttle is WOT.

up striking together.

noise.



PayPal American Express Discover MasterCard VISA

DESCRIPTION AND OPERATION (Continued)

Tools and Techniques

Electronic Vibration Analyzer (EVA)

The EVA is a hand-held electronic diagnostic tool which will assist in locating the source of unacceptable vibrations. The vibration sensor can be remotely mounted anywhere in the vehicle for testing purposes. The unit displays the three most common vibration frequencies and their corresponding amplitudes simultaneously. A bar graph provides a visual reference of the relative signal strength (amplitude) of each vibration being displayed and its relative G force. The keypad is arranged to make the EVA simple to program and use. Some of the functions include the ability to average readings as well as record, play back and freeze readings. The EVA has a strobe balancing function that can be used to detect imbalance on rotating components such as a driveshaft or engine accessories.

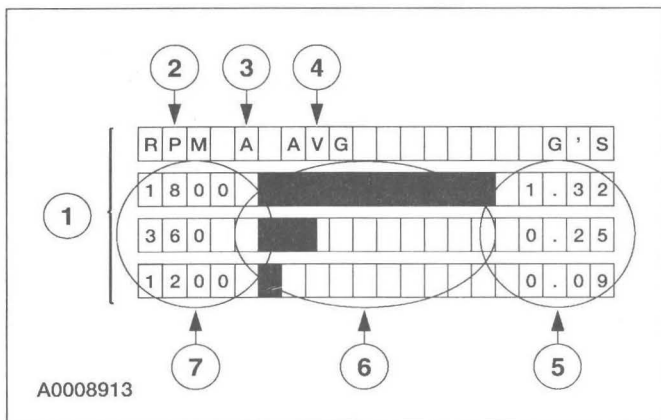

Item	Description
1	EVA screen
2	Frequency mode displayed in rpm or Hz
3	Active sensor input (A or B)
4	Current active mode
5	G force indicators or the strongest frequencies in descending strength of each vibration
6	Strength of each vibration
7	Frequency in rpm/Hz of each vibration

The EVA allows for a systematic collection of information that is necessary to accurately diagnose and repair NVH problems. For the best results, carry out the test as follows:

- Test drive the vehicle with the vibration sensor inside the vehicle.
- Place the sensor in the vehicle according to feel.
 - If the condition is felt through the steering wheel, the source is most likely in the front of the vehicle.
 - A vibration that is felt in the seat or floor only will most likely be found in the driveline, drive axle or rear wheels and tires.
- Record the readings. Also note when the condition begins, when it reaches maximum intensity, and if it tends to diminish above/below a certain speed.
 - Frequencies should be read in the "average" mode.
 - Frequencies have a range of plus or minus 2. A reading of 10 Hz can be displayed as an 8 Hz through 12 Hz.
- Place the vibration sensor on or near the suspect area outside the vehicle.
- Continue the road test, driving the vehicle at the speed the symptom occurs, and take another reading.
- Compare the readings.
 - A match in frequency indicates the problem component or area.
 - An unmatched test could indicate the concern is caused by the engine, torque converter, or engine accessory. Use the EVA in the rpm mode and check if concern is rpm related.
 - Example: A vibration is felt in the seat. Place the sensor on the console. Record the readings. Place the vibration sensor on the rear axle. Compare the readings. If the frequencies are the same, the axle is the problem component.

100% SATISFACTION GUARANTEED

BUY IT NOW!

Click Here To Order

DESCRIPTION AND OPERATION (Continued)

Vibrate Software®

Vibrate Software® (Rotunda tool number 215-00003) is a diagnostic aid which will assist in pinpointing the source of unacceptable vibrations. The engine's crankshaft is the point of reference for vibration diagnosis. Every rotating component will have an angular velocity that is faster, slower, or the same as the engine's crankshaft. Vibrate Software® calculates the angular velocity of each component and graphically represents these velocities on a computer screen and on a printed vibration worksheet. The following steps outline how Vibrate Software® helps diagnose a vibration concern:

- Enter the vehicle information. Vibrate will do all the calculations and display a graph showing tire, driveshaft and engine vibrations.
- Print a Vibration Worksheet graph. The printed graph is to be used during the road test.
- Road test the vehicle at the speed where the vibration is most noticeable. Record the vibration frequency (rpm) and the engine rpm on the worksheet graph. The point on the graph where the vibration frequency (rpm) reading and the engine rpm reading intersect indicates the specific component group causing the concern.
 - An EVA or equivalent tool capable of measuring vibration frequency and engine rpm will be needed.
- Provide pictures of diagnostic procedures to aid in testing components.

Combination EngineEAR/ChassisEAR

An electronic listening device used to quickly identify noise and the location under the chassis while the vehicle is being road tested. The ChassisEARs can identify the noise and location of damaged/worn wheel bearings, CV joints, brakes, springs, axle bearings or driveshaft carrier bearings.

EngineEAR Basic Unit

An electronic listening device used to detect even the faintest noises. The EngineEARs can detect the noise of damaged/worn bearings in generators, water pumps, A/C compressors and power steering pumps. They are also used to identify noisy lifters, exhaust manifold leaks, chipped gear teeth and for detecting wind noise. The EngineEAR has a sensing tip, amplifier, and headphones. The directional sensing tip is used to listen to the various components. Point the sensing tip at the suspect component and adjust the volume with the amplifier. Placing the tip in direct contact with a component will reveal structure-borne noise and vibrations, generated by or passing through, the component. Various volume levels can reveal different sounds.

Ultrasonic Leak Detector

The Ultrasonic Leak Detector is used to detect wind noises caused by leaks and gaps in areas where there is weather-stripping or other sealing material. It is also used to identify A/C leaks, vacuum leaks and evaporative emission noises. The Ultrasonic Leak Detector includes a multi-directional transmitter (operating in the ultrasonic range) and a hand-held detector. The transmitter is placed inside the vehicle. On the outside of the vehicle, the hand-held detector is used to sweep the area of the suspected leak. As the source of the leak is approached, a beeping sound is produced which increases in both speed and frequency.

Squeak and Rattle Repair Kit

The squeak and rattle repair kit (Rotunda tool number 164-R4900) contains lubricants and self-adhesive materials that can be used to eliminate interior and exterior squeaks and rattles. The kit consists of the following materials:

- PVC (soft foam) tape
- Urethane (hard foam) tape
- Flocked (black fuzzy) tape
- UHMW (frosted) tape
- Squeak and rattle oil tube
- Squeak and rattle grease tube

100% SATISFACTION GUARANTEED

BUY IT NOW!

Click Here To Order

PayPal American Express Discover MasterCard VISA

DESCRIPTION AND OPERATION (Continued)

Tracing Powder

Tracing powder is used to check both the uniformity of contact and the tension of a seal against its sealing surface. These tests are usually done when a suspected air leak/noise appears to originate from the seal area or during the alignment and adjustment of a component to a weatherstrip. Tracing powder can be ordered from Crest Industries as ATR Leak Trace. Carry out the tracing powder test as follows:

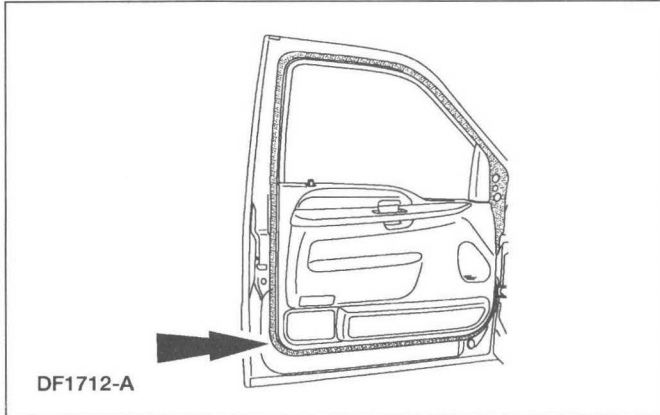

- Clean the weatherstrip.
- Spray the tracing powder on the mating surface only.
- Close the door completely. Do not slam the door.
- Open the door. An imprint is made where the weatherstrip contacted the mating surface seal. Gaps or a faint imprint will show where there is poor contact with the weatherstrip.

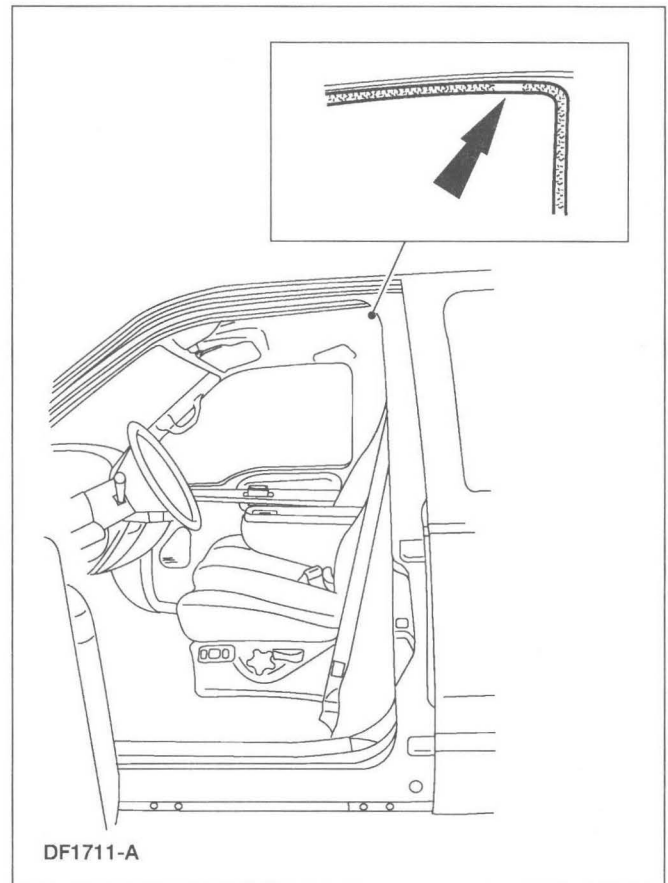

Index Card

Place an index card or a piece of paper between the weatherstrip and the sealing surface, then close the door. Slowly withdraw the index card or paper after the door is closed and check the amount of pressure on the weatherstrip. There should be a medium amount of resistance as it is withdrawn. Continue around the entire seal area. If there is little or no resistance, this indicates insufficient contact to form a good seal. At these points, the door, the glass, or the weatherstrip is out of alignment.

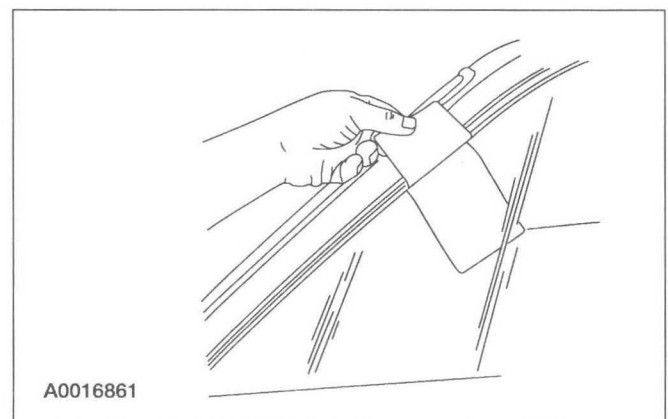

100% SATISFACTION GUARANTEED

BUY IT NOW!





Click Here To Order

PayPal | American Express | Discover | MasterCard | VISA

DIAGNOSIS AND TESTING

Noise, Vibration and Harshness (NVH)

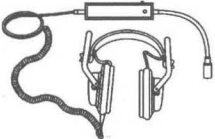
Special Tool(s)

 <p>ST2048-A</p>	<p>ChassisEAR 107-R2102 or Equivalent</p>
 <p>ST2311-A</p>	<p>Vibration Analyzer 100-F027 (014-00344) or Equivalent</p>
 <p>ST2312-A</p>	<p>EngineEAR 107-R2100 or Equivalent</p>
 <p>ST2314-A</p>	<p>Ultrasonic Leak Detector 134-R0135 or Equivalent</p>

To assist the service advisor and the technician, a Write-up Job Aid and an NVH Diagnostic Guide are included with this material. The Write-up Job Aid serves as a place to record all important symptom information. The NVH Diagnostic Guide serves as a place to record information reported on the Write-up Job Aid as well as data from the testing to be carried out.

100% SATISFACTION GUARANTEED

BUY IT NOW!

Click Here To Order



DIAGNOSIS AND TESTING (Continued)

NVH DIAGNOSTIC GUIDE

Dealer: _____ Date: _____

P.A. Code: _____ Order No. _____ Technician: _____

Owner's Name: _____ Address: _____

Phone No. Home: _____ Work: _____

Vehicle Make: _____ Model: _____ Year: _____

VIN: _____ Mileage: _____ Engine: _____ Trans: _____ Axle: _____

OWNER'S DESCRIPTION OF COMPLAINT:

Did Condition Exist When Vehicle Was New? Yes / No (circle one)

How Did Condition Begin? Gradually Suddenly

At What Mileage Did It Occur Or Begin Occuring? _____

Which Driving Conditions Affect The Vehicle?

- Light Accel Closed Throttle Decel Brakes Applied/Released
- Medium Accel Coast (Float) Driving The Vehicle: Straight
- Heavy Accel Constant Speed Cornering

Is Vibration Noticed? If So, Where:

- Seat Steering Wheel Instrument Panel Floor Body Panels Ft/Rr of Vehicle

Is There Sound Or Sensation Of Sound? Yes / No (circle one)

If So, Describe The Sound :

- Boom Hum Whine Growl Other: _____
- Drone Tip-In-Moan Squeak Rattle

PREDRIVE CHECKS

Tire Condition/Pressure: _____

Vehicle Body Damage? _____

Other: _____

ROAD TEST:

Vibration/Noise Occurs:

Vehicle Speed _____ Accel _____ Vibration Frequency _____ Hz/RPM
 Gear Range _____ Decel/Coast _____ Engine Speed _____ RPM

ENGINE RUN-UP TESTS

Neutral Engine Run-Up (NERU) Yes / No Engine RPM _____ Vibration/Frequency _____ Hz/RPM

Drive Engine Run-Up (DERU) Yes / No Engine RPM _____ Vibration/Frequency _____ Hz/RPM

Drivetrain Run-Up (DTRU) Yes / No Engine RPM _____ Vibration/Frequency _____ Hz/RPM

Indicate Suspected Area of Concern:

- Tire/Wheel/Brakes Engine/Accessory Rear
- Driveline/Axle Susp/Steering Right
- Body Front Left
- Other _____

Equipment Used:

- Reed Tachometer Electronic Noise Detector Tape
- Engine Tachometer Ultrasonic Leak Detector Other _____

688-A



BUY IT NOW!

Click Here To Order 







DIAGNOSIS AND TESTING (Continued)

WHEEL/TIRE/BRAKES CHECK:

Balance Check **Yes / No**

Maximum Runout Allowed:

Wheel: Radial _____ Lateral _____

Tire: Radial _____ Lateral _____

Measured Runout:

Tire/Wheel Radial: LF _____ LR _____ RF _____ RR _____

Lateral: LF _____ LR _____ RF _____ RR _____

Wheel Only Radial: LF _____ LR _____ RF _____ RR _____

Lateral: LF _____ LR _____ RF _____ RR _____

SUSPENSION INSPECTION:

Can Cause: Shimmy Clunk Squeak Harshness

Suspension Bushings: Loose Worn Missing OK

Front Upper Control Arm Stabilizer (sway bar) Rear Lower Control Arm

Front Lower Control Arm Rear Upper Control Arm Rear Upper Control Arm

Other _____

Suspension/Steering Components:

Loose Worn Missing OK

Ball Joints Idler Arm Pitman Arm

Shock Absorbers F/R Center Link Steering Gear

Springs F/R Tie Rod Ends/Sleeve Steering Coupler

DRIVESHAFT CONDITION:

Noise Vibration

Balance Weights Missing/Other Visual Defects? **Yes / No**

Maximum Allowable Runout: _____

Actual Runout: Front _____ Middle _____ Rear _____

Two-Piece Driveshaft Runout: Front _____ Rear _____

Middle Support Bearing: Loose Damaged Worn Other _____

Suspect Driveshaft Balanced? **Yes / No**

Pinion Angle: Engine Height: Specification _____ Actual _____

Pinion Angle: Specification _____ Actual _____

Driveline Angle - Truck: Specification _____ Actual _____

ENGINE/ACCESSORY CHECK:

Visual Inspection for Damage or Grounded Condition:

Powertrain Mounts Fuel Lines A/C Lines Power Steering/Cooler Lines

Air Intake Accessories Exhaust Radiator/Condenser

BODY (NOISE/RATTLE)

Indicate Suspected Area of Concern: Doors Windows Dash Panel Other _____

Tests Used to Isolate

NVH Concern: Vacuum/Leak Detector Ultrasonic Leak Detector Tracing Powder

Electronic Noise Detector Other _____

ROAD/ENGINE RUN-UP TESTS: Improved? **Yes / No** Vehicle Acceptable? **Yes / No**

Comments: _____

3914



BUY IT NOW!

Click Here To Order



DIAGNOSIS AND TESTING (Continued)

1: Customer Interview

The diagnostic process starts with the customer interview. The service advisor must obtain as much information as possible about the problem and take a test drive with the customer. There are many ways a customer will describe NVH concerns and this will help minimize confusion arising from descriptive language differences. It is important that the concern is correctly interpreted and the customer descriptions are recorded. During the interview, ask the following questions:

- When was it first noticed?
- Did it appear suddenly or gradually?
- Did any abnormal occurrence coincide with or precede its appearance?

Use the information gained from the customer to accurately begin the diagnostic process.

2: Pre-Drive Check

It is important to do a pre-drive check before road testing the vehicle. A pre-drive check verifies that the vehicle is relatively safe to drive and eliminates any obvious faults on the vehicle.

The pre-drive check consists of a brief visual inspection. During this brief inspection, take note of anything that will compromise safety during the road test and make those repairs/adjustments before taking the vehicle on the road.

3: Preparing for the Road Test

Observe the following when preparing for the road test:

- Review the information recorded on the NVH Diagnostic Guide. It is important to know the specific concern the customer has with the vehicle.
- Do not be misled by the reported location of the noise/vibration. The cause can actually be some distance away.

- Remember that the vibrating source component (originator) may only generate a small vibration. This small vibration can in turn cause a larger vibration/noise to emanate from another receiving component (reactor), due to contact with other components (transfer path).
- Conduct the road test on a quiet street where it is safe to duplicate the vibration/noise. The ideal testing route is an open, low-traffic area where it is possible to operate the vehicle at the speed in which the condition occurs.
- If possible, lower the radio antenna in order to minimize turbulence. Identify anything that could potentially make noise or be a source of wind noise. Inspect the vehicle for add-on items that create vibration/noise. Turn off the radio and the heating and cooling system blower.
- The engine speed is an important factor in arriving at a final conclusion. Therefore, connect an accurate tachometer to the engine, even if the vehicle has a tachometer. Use a tachometer that has clearly defined increments of less than 50 rpm. This ensures an exact engine speed reading.

4: Verify the Customer Concern

Verify the customer concern by carrying out a road test, an engine run-up test, or both.

The decision to carry out a road test, an engine run-up test, or both depends on the type of NVH concern. A road test may be necessary if the symptom relates to the suspension system or is sensitive to torque. A Drive Engine Run-Up (DERU) or a Neutral Engine Run-Up (NERU) Test identifies noises and vibrations relating to engine and drivetrain rpm. Remember, a condition will not always be identifiable by carrying out these tests, however, they will eliminate many possibilities if carried out correctly.



DIAGNOSIS AND TESTING (Continued)

5: Road Test

NOTE: It may be necessary to have the customer ride along or drive the vehicle to point out the concern. During the road test, take into consideration the customer's driving habits and the driving conditions. The customer's concern just may be an acceptable operating condition for that vehicle.

The following is a brief overview of each test in the order in which it appears. A review of this information helps to quickly identify the most appropriate process necessary to make a successful diagnosis. After reviewing this information, select and carry out the appropriate test(s), proceeding to the next step of this process.

- The Slow Acceleration Test is normally the first test to carry out when identifying an NVH concern, especially when a road test with the customer is not possible.
- The Heavy Acceleration Test helps to determine if the concern is torque-related.
- The Neutral Coast Down Speed Test helps to determine if the concern is vehicle speed-related.
- The Downshift Speed Test helps to determine if the concern is engine speed-related.
- The Steering Input Test helps to determine how the wheel bearings and other suspension components contribute to a vehicle speed-related concern.
- The Brake Test helps to identify vibrations or noise that are brake related.
- The Road Test Over Bumps helps isolate a noise that occurs when driving over a rough or bumpy surface.
- The Engine Run-Up Tests consist of the Neutral Run-Up Test and the Engine Load Test. These tests help to determine if the concern is engine speed-related.
- The Neutral Run-Up Test is used as a follow-up test to the Downshift Speed Test when the concern occurs at idle.
- The Engine Load Test helps to identify vibration/noise sensitive to engine load or torque.

- The Engine Accessory Test helps to locate faulty belts and accessories that cause engine speed-related concerns.
- The Vehicle Cold Soak Procedure helps to identify concerns occurring during initial start-up and when an extended time lapse occurs between vehicle usage.

Slow Acceleration Test

To carry out this test, proceed as follows:

- Slowly accelerate to the speed where the reported concern occurs. Note the vehicle speed, the engine rpm and, if possible, determine the vibration frequency.
- Attempt to identify from what part of the vehicle the concern is coming.
- Attempt to identify the source of the concern.
- Proceed as necessary.

Heavy Acceleration Test

To carry out this test, proceed as follows:

- Accelerate hard from 0-64 km/h (0-40 mph).
- Decelerate in a lower gear.
- The concern is torque related if duplicated while carrying out this test.
- Proceed as necessary.

Neutral Coast Down Speed Test

To carry out this test, proceed as follows:

- Drive at a higher rate of speed than where the concern occurred when carrying out the Slow Acceleration Test.
- Place the transmission in NEUTRAL and coast down past the speed where the concern occurs.
- The concern is vehicle speed-related if duplicated while carrying out this test. This eliminates the engine and the torque converter as sources.
- If the concern was not duplicated while carrying out this test, carry out the Downshift Speed Test to verify if the concern is engine speed related.
- Proceed as necessary.

Downshift Speed Test

To carry out this test, proceed as follows:

- Shift into a lower gear than the gear used when carrying out the Slow Acceleration Test.

100% SATISFACTION GUARANTEED

BUY IT NOW!

Click Here To Order

PayPal American Express Discover MasterCard VISA

DIAGNOSIS AND TESTING (Continued)

- Drive at the engine rpm where the concern occurs.
- The concern is engine speed related if duplicated while carrying out this test. This eliminates the tires, wheels, brakes and the suspension components as sources.
- If necessary, repeat this test using other gears and NEUTRAL to verify the results.
- Proceed as necessary.

Steering Input Test

To carry out this test, proceed as follows:

- Drive at the speed where the concern occurs, while making sweeping turns in both directions.
- If the concern goes away or gets worse, the wheel bearings, hubs, U-joints (contained in the axles of 4WD applications), and tire tread wear are all possible sources.
- Proceed as necessary.

Brake Test

To carry out this test, proceed as follows:

- Warm the brakes by slowing the vehicle a few times from 80-32 km/h (50-20 mph) using light braking applications. At highway speeds of 89-97 km/h (55-60 mph), apply the brake using a light pedal force.
- Accelerate to 89-97 km/h (55-60 mph).
- Lightly apply the brakes and slow the vehicle to 30 km/h (20 mph).
- A brake vibration noise can be felt in the steering wheel, seat or brake pedal. A brake noise can be heard upon brake application and diminish when the brake is released.

Road Test Over Bumps

To carry out this test, proceed as follows:

- Drive the vehicle over a bump or rough surface one wheel at a time to determine if the noise is coming from the front or the back and the left or the right side of the vehicle.
- Proceed as necessary.

Neutral Engine Run-Up (NERU) Test

To carry out this test, proceed as follows:

- Install a tachometer.
- Increase the engine rpm up from an idle to approximately 4000 rpm while in PARK on front wheel drive vehicles with automatic transmissions, or NEUTRAL for all other vehicles. Note the engine rpm and, if possible, determine the vibration frequency.
- Attempt to identify what part of the vehicle the concern is coming from.
- Attempt to identify the source of the concern.
- Proceed as necessary.

Drive Engine Run-Up (DERU) Load Test

To carry out this test, proceed as follows:

-  **WARNING: Block the front and rear wheels, and apply the parking brake and the service brake, or injury to personnel can result.**

 **CAUTION: Do not carry out the Engine Load Test for more than five seconds or damage to the transmission or transaxle can result.**
Block the front and rear wheels.

- Apply the parking brake and the service brake.
- Install a tachometer.
- Shift the transmission into DRIVE, and increase and decrease the engine rpm between an idle to approximately 2000 rpm. Note the engine rpm and, if possible, determine the vibration frequency.
- Repeat the test in REVERSE.
- If the vibration/noise is duplicated when carrying out this test, inspect the engine and transmission or transaxle mounts.
- If the concern is definitely engine speed-related, carry out the Engine Accessory Test to narrow down the source.
- Proceed as necessary.



100% SATISFACTION GUARANTEED

BUY IT NOW!

Click Here To Order

PayPal American Express Discover MasterCard VISA

DIAGNOSIS AND TESTING (Continued)

Engine Accessory Test

To carry out this test, proceed as follows:

-  **WARNING: Block the front and rear wheels, and apply the parking brake and the service brake, or injury to personnel can result.**

 **CAUTION: Limit engine running time to one minute or less with belts removed or serious engine damage will result.**

NOTE: A serpentine drive belt decreases the usefulness of this test. In these cases, use a vibration analyzer, such as the VA, to pinpoint accessory vibrations. An electronic listening device, such as an EngineEAR, will also help to identify noises from specific accessories.

Remove the accessory drive belts.

- Increase the engine rpm to where the concern occurs.
- If the vibration/noise is duplicated when carrying out this test, the belts and accessories are not sources.
- If the vibration/noise was not duplicated when carrying out this test, install each accessory belt, one at a time, to locate the source.

Vehicle Cold Soak Procedure

To carry out this procedure, proceed as follows:

- Test preparations include matching customer conditions (if known). If not known, document the test conditions: gear selection and engine rpm. Monitor the vibration/noise duration with a watch for up to three minutes.
- Park the vehicle where testing will occur. The vehicle must remain at or below the concern temperature (if known) for 6-8 hours.
- Before starting the engine, conduct a visual inspection under the hood.
- Turn the key on, but do not start the engine. Listen for the fuel pump, anti-lock brake system (ABS) and air suspension system noises.
- Start the engine.

-  **CAUTION: Never probe moving parts.**
Isolate the vibration/noise by carefully listening. Move around the vehicle while listening to find the general location of the vibration/noise. Then, search for a more precise location by using a stethoscope or EngineEAR.
- Refer to Idle Noise/Vibration in the Symptom Chart to assist with the diagnosis.

6: Check OASIS/TSBs/Repair History

After verifying the customer concern, check for OASIS reports, TSBs and the vehicle repair history for related concerns. If information relating to a diagnosis/repair is found, carry out the procedure(s) specified in that information.

If no information is available from these sources, carry out the vehicle preliminary inspection to eliminate any obvious faults.

7: Diagnostic Procedure

Qualifying the concern by the particular sensation present can help narrow down the concern. Always use the “symptom” to “system” to “component” to “cause” diagnosis technique. This diagnostic method divides the problem into related areas to correct the customer concern.

- Verify the “symptom”.
- Determine which “system(s)” can cause the “symptom”.
 - If a vibration concern is vehicle speed related, the tire and wheel rpm/frequency or driveshaft frequency should be calculated.
 - If a vibration concern is engine speed related, the engine, engine accessory or engine firing frequencies should be calculated.
- After determining the “system”, use the diagnostic tools to identify the worn or damaged “components”.
- After identifying the “components”, try to find the “cause” of the failure.

Once the concern is narrowed down to a symptom/condition, proceed to NVH Condition and Symptom Categories.



DIAGNOSIS AND TESTING (Continued)

NVH Condition and Symptom Categories

A good diagnostic process is a logical sequence of steps that lead to the identification of a causal system. Use the condition and symptom categories as follows:

- Identify the operating condition that the vehicle is exhibiting.
- Match the operating condition to the symptom.
- Verify the symptom.
- Identify which category or system could cause the symptom.
- Refer to the diagnostic symptom chart that is referred to.

Operating Condition—Vehicle is Not Moving

1. Static operation
 - Noise occurs during component/system functioning. GO to Symptom Chart - Squeak and Rattle.
2. While cranking
 - 1 Grinding or whine, differential ring gear or starter motor pinion noise. GO to Symptom Chart - Engine Noise/Vibration.
 - 2 Rattle. Exhaust hanger, exhaust heat shield or A/C line noise. GO to Symptom Chart - Squeak and Rattle.
 - 3 Vibration. Acceptable condition.
3. At idle
 - Idle noise. GO to Symptom Chart - Idle Noise/Vibration.
 - Idle vibration or shake. GO to Symptom Chart - Idle Noise/Vibration.
4. During Gear Selection
 - 1 Vehicle parked on a steep incline. Acceptable noise.
 - 2 Vehicle parked on a flat surface. GO to Symptom Chart - Driveline Noise/Vibration.
 - 3 Vehicle with a manual transmission. GO to Symptom Chart - Transmission (Manual) and Transfer Case Noise/Vibration.

Operating Condition—Vehicle is Moving

1. Depends more on how the vehicle is operated
 - 1 Speed related
 - Related to vehicle speed
 - Pitch increases with vehicle speed. GO to Symptom Chart - Tire Noise/Vibration.
 - Noise occurs at specific vehicle speed. A high-pitched noise (whine). GO to Symptom Chart - Driveline Noise/Vibration.
 - Loudness proportional to vehicle speed. Low-frequency noise at high speeds, noise and loudness increase with speed. GO to Symptom Chart - Driveline Noise/Vibration.
 - A low-pitched noise (drumming). GO to Symptom Chart - Engine Noise/Vibration.
 - Vibration occurs at a particular speed (mph) regardless of acceleration or deceleration. GO to Symptom Chart - Tire Noise/Vibration.
 - Noise varies with wind/vehicle speed and direction. GO to Symptom Chart - Air Leak and Wind Noise.
 - Related to engine speed
 - Noise varies with engine rpm. GO to Symptom Chart - Engine Noise/Vibration.
 - Vibration occurs at a particular speed (mph) regardless of engine speed (rpm).
 - 2 Acceleration
 - Wide open throttle (WOT)
 - Engine induced contact between components. Inspect and repair as necessary.
 - Noise is continuous throughout WOT. Exhaust system or engine ground out. GO to Symptom Chart - Engine Noise/Vibration.
 - Light/moderate acceleration
 - Tip-in moan. Engine/exhaust noise. GO to Symptom Chart - Engine Noise/Vibration.



DIAGNOSIS AND TESTING (Continued)

- Knock-type noise. GO to Symptom Chart - Engine Noise/Vibration.
 - Driveline shudder. GO to Symptom Chart - Driveline Noise/Vibration.
 - Engine vibration. GO to Symptom Chart - Engine Noise/Vibration.
- 3 Turning noise. GO to Symptom Chart - Steering Noise/Vibration.
- 4 Braking
- Clicking sound is signaling ABS is active. Acceptable ABS sound.
 - A continuous grinding/squeal. GO to Symptom Chart - Brake Noise/Vibration.
 - Brake vibration/shudder. GO to Symptom Chart - Brake Noise/Vibration.
- 5 Clutching
- A noise occurring during clutch operation. GO to Symptom Chart - Transmission (Manual) and Transfer Case Noise/Vibration.
 - Vibration. GO to Symptom Chart - Transmission (Manual) and Transfer Case Noise/Vibration.
- 6 Shifting
- Noise or vibration condition related to the transmission (automatic). GO to Symptom Chart - Transmission (Automatic) Noise/Vibration.
 - Noise or vibration related to the transmission (manual). GO to Symptom Chart - Transmission (Manual) and Transfer Case Noise/Vibration.
- 7 Engaged in four-wheel drive. GO to Symptom Chart - Transmission (Manual) and Transfer Case Noise/Vibration.
- 8 Cruising speeds
- Accelerator pedal vibration. GO to Symptom Chart - Engine Noise/Vibration.
 - Driveline vibration. GO to Symptom Chart - Driveline Noise/Vibration.
 - A shimmy or shake. GO to Symptom Chart - Tire Noise/Vibration.
- 9 Driving at low/medium speeds
- A wobble or shudder. GO to Symptom Chart - Tire Noise/Vibration.
2. Depends more on where the vehicle is operated
- 1 Bump/pothole, rough road or smooth road. GO to Symptom Chart - Suspension Noise/Vibration.
- Noise is random or intermittent occurring from road irregularities. GO to Symptom Chart - Squeak and Rattle.
 - Noise or vibration changes from one road surface to another. Normal sound changes.
 - Noise or vibration associated with a hard/firm ride. GO to Symptom Chart - Suspension Noise/Vibration.

Symptom Charts**Symptom Chart — Air Leak and Wind Noise**

Condition	Possible Sources	Action
<ul style="list-style-type: none"> • Air leak around door perimeter 	<ul style="list-style-type: none"> • Loose fit seal. • Seal installed incorrectly. • Door misaligned. • Scuff plate installed incorrectly. • Seal or seal push pins damaged. 	<ul style="list-style-type: none"> • PINCH the seal carrier to improve retention on the seal flange. • REINSTALL the seal. • REALIGN the door. CHECK door gaps and fit in the door opening and ADJUST as necessary. • REINSTALL the scuff plate. • INSTALL a new seal.



DIAGNOSIS AND TESTING (Continued)**Symptom Chart — Air Leak and Wind Noise (Continued)**

Condition	Possible Sources	Action
<ul style="list-style-type: none"> Air leak around glass run 	<ul style="list-style-type: none"> Door glass misaligned. Glass run installed incorrectly. Leak path behind glass run. Glass run channel spread wide. Blow-out clip bent or contacting door glass. Glass run damaged. 	<ul style="list-style-type: none"> ADJUST the door glass. ADJUST the glass run. INSERT foam in the glass run carrier. INSTALL foam rope behind the glass run. PINCH the glass run channel to reduce the size of the opening. ADJUST the blow-out clip or INSTALL a new glass run/blow-out clip molding assembly. INSTALL a new glass run.
<ul style="list-style-type: none"> Air leak at inner belt line 	<ul style="list-style-type: none"> Belt line seal installed incorrectly on flange. Belt line seal integrated with door trim installed incorrectly (no glass contact). No contact with side glass. No contact with glass runs at both ends of belt line seal. Belt line seal damaged. 	<ul style="list-style-type: none"> ADJUST the seal. (Do not bend the flange.) REINSTALL the door trim. ADJUST the door glass. ADJUST the belt line seal or ADD foam at the seal ends. INSTALL a new seal.
<ul style="list-style-type: none"> Air leak at outer belt line 	<ul style="list-style-type: none"> Belt line seal installed incorrectly on flange (no glass contact). Belt line seal does not contact the glass. No contact with glass runs at both ends of belt line seal. Belt line seal damaged. 	<ul style="list-style-type: none"> ADJUST the seal. ADJUST the door glass. ADJUST the belt line seal/ADD foam at the seal ends. INSTALL a new seal.
<ul style="list-style-type: none"> Draft at inner door handle/speaker opening 	<ul style="list-style-type: none"> Hole in watershield. Watershield misaligned. Exterior door handle seal misaligned/damaged. 	<ul style="list-style-type: none"> SEAL the hole with a suitable tape. REALIGN the watershield. INSTALL a new watershield if the pressure sensitive adhesive fails. REALIGN or INSTALL a new seal as necessary.



SATISFACTION 100% GUARANTEED

BUY IT NOW!

Click Here To Order

PayPal American Express Discover MasterCard VISA

DIAGNOSIS AND TESTING (Continued)**Symptom Chart — Air Leak and Wind Noise (Continued)**

Condition	Possible Sources	Action
<ul style="list-style-type: none"> Wind noise from side view mirror 	<ul style="list-style-type: none"> Outside mirror housing misaligned. Mirror sail gasket folded/misaligned. Mirror housing trim cap installed incorrectly. Air leak through mirror housing hinge. Inner sail trim installed incorrectly. Inner sail gasket/barrier installed incorrectly. Air path through wiring bundle/fastener access holes. Exposed fastener access hole on mirror housing/sail. 	<ul style="list-style-type: none"> REALIGN with the edges shingled correctly and no gaps. REINSTALL with the gasket unfolded and aligned correctly. REINSTALL with the edges shingled to the air flow. Fully ENGAGE the mirror into its operating position/USE foam to block the air path through the hinge. REINSTALL the sail trim/ADJUST the door trim. REINSTALL the trim cover with the gasket/barrier aligned correctly. BLOCK the air path(s) with foam/tape. INSTALL a new cap if it is missing.
<ul style="list-style-type: none"> Air leak around perimeter of fixed glass 	<ul style="list-style-type: none"> Gaps in the sealant bead. Air traveling up windshield molding along A-pillar. Windshield/backlite misaligned or not installed correctly. Rear hood seal at base of windshield misaligned/damaged. 	<ul style="list-style-type: none"> APPLY approved sealant. INSTALL foam rope the full length of the A-pillar. REINSTALL the windshield/backlite. REALIGN or INSTALL a new seal as necessary.
<ul style="list-style-type: none"> Air leak at cowl 	<ul style="list-style-type: none"> Cowl gasket misaligned/damaged. 	<ul style="list-style-type: none"> REALIGN or INSTALL a new seal as necessary.
<ul style="list-style-type: none"> Air leak around liftgate perimeter 	<ul style="list-style-type: none"> Loose fit seal. Seal misaligned. Liftgate misaligned. Scuff plate misaligned. Seal or seal push pins damaged. 	<ul style="list-style-type: none"> PINCH the seal carrier to improve retention on the seal flange or INSERT foam in the carrier. REINSTALL the seal. REALIGN the liftgate. CHECK the liftgate fit in the body opening and ADJUST as necessary. REINSTALL the scuff plate. INSTALL a new seal.
<ul style="list-style-type: none"> Air leak around the liftgate flip window perimeter 	<ul style="list-style-type: none"> Loose fit seal. Seal misaligned. Glass misaligned. Seal damaged. 	<ul style="list-style-type: none"> PINCH the seal carrier to improve the retention to the seal flange. REINSTALL the seal. REALIGN the glass. INSTALL a new seal.
	<ul style="list-style-type: none"> Shape of antenna. Air leak around antenna cable access hole. 	<ul style="list-style-type: none"> INSTALL an antenna boot or a spiral antenna. INSPECT the antenna access hole grommet. REPAIR as necessary.



BUY IT NOW!

Click Here To Order



DIAGNOSIS AND TESTING (Continued)**Symptom Chart — Air Leak and Wind Noise (Continued)**

Condition	Possible Sources	Action
<ul style="list-style-type: none"> Air leak from closed roof opening panel 	<ul style="list-style-type: none"> Seal installed incorrectly. Roof opening panel glass/door misaligned. Roof opening panel damaged. 	<ul style="list-style-type: none"> REINSTALL the seal. REALIGN the roof opening panel glass/door. INSTALL a new roof opening panel.
<ul style="list-style-type: none"> Buffeting from an open roof opening panel 	<ul style="list-style-type: none"> Wind deflector inoperative/damaged. Wind deflector height incorrect. 	<ul style="list-style-type: none"> REPAIR or INSTALL a new wind deflector as necessary. ADJUST the wind deflector higher.
<ul style="list-style-type: none"> Wind noise created by airflow over or behind body panels 	<ul style="list-style-type: none"> Fender splash shield misaligned. Body panel misaligned (exposed edge). Hood misaligned (front margin). Front grille edge noise. 	<ul style="list-style-type: none"> REALIGN the fender splash shield. REALIGN the appropriate body panel. CHECK hood gaps and fit. ADJUST the hood as necessary. APPLY foam in the hollow areas behind the louvers.
<ul style="list-style-type: none"> Wind noise created by grille opening panel 	<ul style="list-style-type: none"> Grille relationship to leading edge on hood. Sharp edges due to material imperfections. 	<ul style="list-style-type: none"> ADJUST the grille opening panel forward to eliminate wind noise. REMOVE the sharp edges (no damage to visible surface).
<ul style="list-style-type: none"> Wind noise from air extractor 	<ul style="list-style-type: none"> Air extractor housing seated incorrectly. Air extractor housing or flaps damaged. 	<ul style="list-style-type: none"> REINSTALL the air extractor housing. INSTALL a new air extractor.
<ul style="list-style-type: none"> Air leak at top of A-pillar — vehicles with a convertible top 	<ul style="list-style-type: none"> Seal at windshield header installed incorrectly. Seal pinched. Gap between side rail and header seal at A-pillar. 	<ul style="list-style-type: none"> REINSTALL the seal. FILL the seal with foam to reshape it. ADJUST the J-hook/vinyl top.
<ul style="list-style-type: none"> Air leak at rear quarter glass (division bar) — vehicles with a convertible top 	<ul style="list-style-type: none"> No contact between front side glass and quarter glass division bar. 	<ul style="list-style-type: none"> ADJUST the front side glass regulator and the rear quarter glass regulator.
<ul style="list-style-type: none"> Air leak or wind noise from top of side glass — vehicles with a convertible top 	<ul style="list-style-type: none"> Gap between side rail and vinyl top. Seal at windshield header installed incorrectly. Seal damaged between side rail and vinyl top. Vinyl top damaged. 	<ul style="list-style-type: none"> ADD additional foam tape to seal between the side rail and the vinyl top. REINSTALL the seal. INSTALL a new seal. INSPECT the vinyl top. INSTALL a new vinyl top as necessary.
<ul style="list-style-type: none"> Air leak or wind noise at windshield header — vehicles with a convertible top 	<ul style="list-style-type: none"> Vinyl top not flush with header. Seal at windshield header installed incorrectly. Header seal not flush with header. 	<ul style="list-style-type: none"> ADJUST the J-hook to lower the top to achieve a flush condition. REINSTALL the seal. REINSTALL the seal.

BUY IT NOW!
 Click Here To Order 







DIAGNOSIS AND TESTING (Continued)**Symptom Chart — Air Leak and Wind Noise (Continued)**

Condition	Possible Sources	Action
<ul style="list-style-type: none"> Convertible top flapping with the top up 	<ul style="list-style-type: none"> Vinyl top contacting interior headliner. 	<ul style="list-style-type: none"> Working from front to back, INSTALL a 6.35 mm (0.25 in) foam sheet between the headliner and the vinyl top at the suspected area. Allow a clearance of 50 mm (2 in) - 75 mm (3 in) away from the roof bows and the side rails.
<ul style="list-style-type: none"> Noise from roof rack 	<ul style="list-style-type: none"> Roof rack rails or crossbars loose. Roof rack fasteners missing. Roof rack crossbars installed backward. Roof rack rub strips partially lifting from roof. Roof rack gaskets loose or misaligned. 	<ul style="list-style-type: none"> TIGHTEN the fasteners. INSTALL the approved fasteners. REINSTALL the crossbars. REAPPLY adhesive or fasteners or INSTALL new rub strips as necessary. REINSTALL the gasket.
<ul style="list-style-type: none"> Wind noise from bug shield/exterior windshield sun visor 	<ul style="list-style-type: none"> Turbulence created by location and shape. 	<ul style="list-style-type: none"> REMOVE per customer direction if it is a dealer installed option.

Symptom Chart—Brake Noise/Vibration

Condition	Possible Sources	Action
<ul style="list-style-type: none"> Rattling noise 	<ul style="list-style-type: none"> Caliper mounting bolts loose. Damaged or worn caliper pins or retainers. Missing or damaged anti-rattle clips or springs. Loose brake disc shield. 	<ul style="list-style-type: none"> CHECK the caliper bolts. TIGHTEN to specifications. REFER to Section 206-00 for the front disc brake pads or rear disc brake pads. CHECK the caliper pins and retainers for lubrication and correct fit. LUBRICATE or INSTALL new components as necessary. REFER to Section 206-00 for the front disc brake pads or rear disc brake pads. CHECK the brake pads for missing clips or broken springs. INSTALL new components as necessary. REFER to Section 206-00 for the front disc brakes pads or rear disc brake pads. TIGHTEN the brake disc shield bolts to specification. REFER toSection 206-00.
<ul style="list-style-type: none"> Clicking noise—with brakes applied with ABS brakes 	<ul style="list-style-type: none"> ABS hydraulic control unit. 	<ul style="list-style-type: none"> Acceptable condition.
<ul style="list-style-type: none"> Squealing noise—occurs on 	<ul style="list-style-type: none"> Disc brake pads. 	<ul style="list-style-type: none"> Acceptable condition. Caused by humidity and low disc brake pad temperature.

SATISFACTION 100% GUARANTEED

BUY IT NOW!

Click Here To Order

PayPal American Express Discover MasterCard VISA

DIAGNOSIS AND TESTING (Continued)**Symptom Chart—Brake Noise/Vibration (Continued)**

Condition	Possible Sources	Action
<ul style="list-style-type: none"> Squealing noise—a continuous squeal 	<ul style="list-style-type: none"> Disc brake pads or linings worn below minimum thickness. 	<ul style="list-style-type: none"> INSTALL new disc brake pads. REFER to Section 206-00 for the front disc brake pads or rear disc brake pads.
<ul style="list-style-type: none"> Squealing noise—an intermittent squeal brought on by cold, heat, water, mud or snow 	<ul style="list-style-type: none"> Disc brake pad. 	<ul style="list-style-type: none"> Acceptable condition.
<ul style="list-style-type: none"> Groaning noise—occurs at low speeds with brake lightly applied (creeping) 	<ul style="list-style-type: none"> Disc brake pads. 	<ul style="list-style-type: none"> Acceptable condition.
<ul style="list-style-type: none"> Grinding noise—continuous 	<ul style="list-style-type: none"> Disc brake pads or linings worn below minimum thickness. 	<ul style="list-style-type: none"> INSPECT the disc brake pads, brake discs/drums and attaching hardware for damage. REPAIR or INSTALL new components as necessary. REFER to Section 206-00 for front disc brakes or rear disc brakes.
<ul style="list-style-type: none"> Moaning noise 	<ul style="list-style-type: none"> Brake linings contaminated with grease or oil. 	<ul style="list-style-type: none"> INSPECT the brake pads and shoes for contamination. REPAIR or INSTALL new components as necessary. REFER to Section 206-00 for front disc brakes or rear disc brakes.
<ul style="list-style-type: none"> Brake vibration/shudder—occurs when brakes are applied 	<ul style="list-style-type: none"> Uneven disc or drum wear. Uneven disc brake pad or lining transfer. Suspension components. 	<ul style="list-style-type: none"> GO to Pinpoint Test A.
<ul style="list-style-type: none"> Brake vibration/shudder—occurs when the brake pedal is released 	<ul style="list-style-type: none"> Brake drag. 	<ul style="list-style-type: none"> INSPECT the disc brake pads or linings for premature wear. REPAIR or INSTALL a new caliper or wheel cylinder as necessary. REFER to Section 206-00 for front disc brakes or rear disc brakes.



BUY IT NOW!
Click Here To Order



DIAGNOSIS AND TESTING (Continued)

Symptom Chart—Driveline Noise/Vibration

Condition	Possible Sources	Action
<ul style="list-style-type: none"> Axle howling or whine—front or rear axle 	<ul style="list-style-type: none"> Axle lubricant low. Axle housing damage. Damaged or worn wheel bearings or axle bearings. Damaged or worn differential ring and pinion. Damaged or worn differential side or pinion bearings. Damaged or worn differential side gears and pinion gears. 	<ul style="list-style-type: none"> CHECK the lubricant level. FILL the axle to specification. INSPECT the axle housing for damage. REPAIR or INSTALL a new axle as necessary. REFER to Section 205-00 for the rear axle or front axle. CHECK for abnormal wheel bearing play or roughness. Refer to Wheel Bearing Check in this section. ADJUST or INSTALL new wheel bearings as necessary. INSPECT the ring and pinion ring for abnormal wear patterns or broken teeth. INSTALL a new ring and pinion as necessary. REFER to Section 205-00 for the rear axle or front axle. CHECK for abnormal bearing play or roughness. INSTALL new bearings as necessary. REFER to Section 205-00 for the rear axle or front axle. DISASSEMBLE the differential carrier. INSPECT the side and pinion gears for abnormal wear patterns or broken teeth. INSTALL new gears as necessary. REFER to Section 205-00 for the rear axle or front axle.
<ul style="list-style-type: none"> Front axle groan, hum or vibration — occurs when operated in 2 high 	<ul style="list-style-type: none"> Front drive axle halfshaft rotational speed variance 	<ul style="list-style-type: none"> REFER to component test Front Drive Axle Halfshaft Rotation Speed in this section.

100% SATISFACTION GUARANTEED

BUY IT NOW!

Click Here To Order

PayPal American Express Cards DISCOVER NOVUS MasterCard VISA

DIAGNOSIS AND TESTING (Continued)**Symptom Chart—Driveline Noise/Vibration (Continued)**

Condition	Possible Sources	Action
<ul style="list-style-type: none"> • Driveline clunk—loud clunk when shifting from reverse to drive 	<ul style="list-style-type: none"> • Incorrect axle lubricant level. • Excessive backlash in the axle or transmission. • Damaged or worn pinion bearings. • Damaged or worn universal joints (U-joints). • Loose suspension components. • Broken powertrain mounts. • Idle speed too high. 	<ul style="list-style-type: none"> • CHECK the lubricant level. FILL the axle to specification. • CARRY OUT a total backlash check. REFER to Section 205-00. • CHECK for abnormal bearing play or roughness. INSTALL new bearings as necessary. REFER to Section 205-00. • INSPECT the U-joints for wear or damage. INSTALL new U-joints as necessary. REFER to Section 205-00. • INSPECT the suspension for damage or wear. REPAIR or INSTALL new components as necessary. • INSPECT the powertrain mounts. REFER to Section 303-01A for 4.6L SOHC engines, Section 303-01B for 5.4L engines or Section 307-01. INSTALL new mounts as necessary. • CHECK for the correct idle speed.
<ul style="list-style-type: none"> • Driveline clunk—occurs as the vehicle starts to move forward following a stop 	<ul style="list-style-type: none"> • Worn or galled driveshaft slip-yoke splines. • Worn or galled driveshaft and coupling shaft splines. • Loose rear leaf spring U-bolts. 	<ul style="list-style-type: none"> • CLEAN and INSPECT the splines of the yoke for a worn or galled condition. INSTALL a new yoke as necessary. REFER to Section 205-00. • CLEAN and INSPECT the splines of the driveshaft and coupling shaft for a worn or galled condition. INSTALL a new driveshaft assembly as necessary. REFER to Section 205-00. • CHECK the U-bolts for loose nuts. TIGHTEN to specification. REFER to Section 204-00.
<ul style="list-style-type: none"> • Driveline clunk (FWD vehicles)—occurs during acceleration or from cruise to coast/deceleration 	<ul style="list-style-type: none"> • Damaged or worn inboard constant velocity (CV) joint. 	<ul style="list-style-type: none"> • INSPECT the inboard CV joint and boot. REPAIR or INSTALL a new CV joint as necessary. REFER to Section 205-00.
<ul style="list-style-type: none"> • Driveline clunk (4WD vehicles)—occurs during shift-on-the-fly engagement 	<ul style="list-style-type: none"> • Clutch relay. • Shift motor. • Transfer case. • 4x4 module. 	<ul style="list-style-type: none"> • CHECK the 4WD engagement system. REPAIR or INSTALL new components as necessary. REFER to Section 308-07.



SATISFACTION 100% GUARANTEED

BUY IT NOW!

Click Here To Order

PayPal American Express Discover MasterCard VISA

DIAGNOSIS AND TESTING (Continued)**Symptom Chart—Driveline Noise/Vibration (Continued)**

Condition	Possible Sources	Action
<ul style="list-style-type: none"> Clicking, popping or grinding—occurs while vehicle is turning 	<ul style="list-style-type: none"> Inadequate or contaminated lubrication in the (CV) joints. Another component contacting the halfshaft Brake components. Steering components. Suspension components. Damaged or worn wheel bearings. 	<ul style="list-style-type: none"> CHECK the CV boots and joints for wear or damage. REPAIR or INSTALL new components as necessary. REFER to Section 205-00. CHECK the halfshafts and the area around the halfshafts. REPAIR as necessary. INSPECT the front brakes for wear or damage. REPAIR as necessary. REFER to Section 206-00. INSPECT the drag link, inner and outer tie-rods or idler arm for wear or damage. REPAIR as necessary. INSPECT the upper and lower ball joints for wear or damage. REPAIR as necessary. REFER to Section 204-00 for 2-wheel drive or 4-wheel drive. CHECK for abnormal wheel bearing play or roughness. Refer to Wheel Bearing Check in this section. ADJUST or INSTALL new wheel bearings as necessary.
<ul style="list-style-type: none"> Clicking or snapping—occurs when accelerating around a corner 	<ul style="list-style-type: none"> Damaged or worn outboard CV joint. 	<ul style="list-style-type: none"> INSPECT the outboard CV joint and boot. REPAIR or INSTALL a new CV joint as necessary. REFER to Section 205-00.
<ul style="list-style-type: none"> High pitched chattering—noise from the rear axle when the vehicle is turning 	<ul style="list-style-type: none"> Incorrect or contaminated lubricant. Damaged or worn differential (differential side gears and pinion gears). 	<ul style="list-style-type: none"> CHECK the vehicle by driving in tight circles (5 clockwise, 5 counterclockwise). FLUSH and REFILL with the specified rear axle lubricant and friction modifier as necessary. DISASSEMBLE the differential assembly. INSPECT the differential case, pin and gears for wear or damage. REPAIR or INSTALL a new differential as necessary. REFER to Section 205-00 for the rear axle or front axle.
<ul style="list-style-type: none"> Buzz—buzzing noise is the same at cruise or coast/deceleration 	<ul style="list-style-type: none"> Damaged or worn tires. Incorrect driveline angles. 	<ul style="list-style-type: none"> CHECK for abnormal tire wear or damage. INSTALL a new tire as necessary. REFER to Section 204-00. CHECK for correct driveline angles. REPAIR as necessary. REFER to Section 205-00.



BUY IT NOW!

Click Here To Order



DIAGNOSIS AND TESTING (Continued)**Symptom Chart—Driveline Noise/Vibration (Continued)**

Condition	Possible Sources	Action
<ul style="list-style-type: none"> Rumble or boom—noise occurs at coast/deceleration, usually driveshaft speed related and noticeable over a wide range of speeds 	<ul style="list-style-type: none"> Driveshaft is out-of-balance. U-joints binding or seized. Excessive pinion flange runout. 	<ul style="list-style-type: none"> CHECK the driveshaft for damage, missing balance weights or undercoating. CHECK the driveshaft balance. CARRY OUT a driveline vibration test. REFER to Section 205-00. ROTATE the driveshaft and CHECK for rough operation or seized U-joints. INSTALL new U-joints as necessary. REFER to Section 205-00. CARRY OUT a runout check. REPAIR as necessary. REFER to Section 205-00.
<ul style="list-style-type: none"> Grunting—normally associated with a shudder experienced during acceleration from a dead stop 	<ul style="list-style-type: none"> Driveshaft slip yoke binding. Loose rear spring U-bolts. 	<ul style="list-style-type: none"> CLEAN and LUBRICATE the male and female splines. INSPECT the rear suspension. TIGHTEN the U-bolt nuts to specification. REFER to Section 204-00.
<ul style="list-style-type: none"> Howl—can occur at various speeds and driving conditions. Affected by acceleration and deceleration 	<ul style="list-style-type: none"> Incorrect ring and pinion contact, incorrect bearing preload or gear damage. 	<ul style="list-style-type: none"> CHECK the ring and pinion and bearings for damage. INSPECT the ring and pinion wear pattern. REFER to Checking Tooth Contact Pattern and Condition of the Ring and Pinion component test in this section. ADJUST or INSTALL new components as necessary. REFER to Section 205-00 for the rear axle or the front axle.
<ul style="list-style-type: none"> Chuckle—heard at coast/deceleration. Also described as a knock 	<ul style="list-style-type: none"> Incorrect ring and pinion contact or by damaged teeth on the coast side of the ring and pinion. 	<ul style="list-style-type: none"> CHECK the ring and pinion for damage. INSPECT the ring and pinion wear pattern. REFER to Checking Tooth Contact Pattern and Condition of the Ring and Pinion component test in this section. ADJUST or INSTALL new components as necessary. REFER to Section 205-00 for the rear axle or front axle.



DIAGNOSIS AND TESTING (Continued)**Symptom Chart—Driveline Noise/Vibration (Continued)**

Condition	Possible Sources	Action
<ul style="list-style-type: none"> • Knock—noise occurs at various speeds. Not affected by acceleration or deceleration 	<ul style="list-style-type: none"> • Gear tooth damage to the drive side of the ring and pinion. • Excessive axle shaft end play. (Vehicles with integral axles). 	<ul style="list-style-type: none"> • CHECK the differential case and ring and pinion for damage. INSTALL new components as necessary. REFER to Section 205-00 for the rear axle or front axle. • CHECK the axle end play using a dial indicator. INSTALL a new axle shaft or side gears as necessary. REFER to Section 205-00.
<ul style="list-style-type: none"> • Scraping noise—a continuous low pitched noise starting at low speeds 	<ul style="list-style-type: none"> • Worn or damaged pinion bearings. 	<ul style="list-style-type: none"> • CHECK the pinion bearings. INSTALL new pinion bearings as necessary. REFER to Section 205-00 for the rear axle or front axle.
<ul style="list-style-type: none"> • Driveline shudder—occurs during acceleration from a slow speed or stop 	<ul style="list-style-type: none"> • Rear drive axle assembly mispositioned. • Loose rear spring U-bolts. • Incorrect or high CV joint operating angle. • Damaged or worn front suspension components. • Driveline angles out of specification. • U-joints binding or seized. • Binding, damaged or galled splines on the driveshaft slip-yoke. 	<ul style="list-style-type: none"> • CHECK the axle mounts and the rear suspension for damage or wear. REPAIR as necessary. • INSPECT the U-bolts. TIGHTEN the U-bolt nuts to specification. REFER to Section 204-00. • CHECK vehicle ride height is within limits. REPAIR as necessary. • CHECK for a loose stabilizer bar, damaged or loose strut/strut bushings or loose or worn ball joints. INSPECT the steering linkage for wear or damage. REPAIR or INSTALL new components as necessary. • CHECK for correct driveline angles. REPAIR as necessary. REFER to Section 205-00. • ROTATE the driveshaft and CHECK for rough operation or seized U-joints. INSTALL new U-joints as necessary. REFER to Section 205-00. • CLEAN and INSPECT the splines of the slip-yoke, driveshaft and coupling shaft for a worn, damaged or galled condition. INSTALL a new slip-yoke or driveshaft assembly as necessary. REPAIR as necessary. REFER to Section 205-00.



BUY IT NOW!

Click Here To Order



DIAGNOSIS AND TESTING (Continued)**Symptom Chart—Driveline Noise/Vibration (Continued)**

Condition	Possible Sources	Action
<ul style="list-style-type: none"> • Driveline vibration—occurs at cruising speeds 	<ul style="list-style-type: none"> • U-joints are worn. • Worn or damaged driveshaft center bearing support. • Loose axle pinion flange bolts • Excessive axle pinion flange runout. • Driveshaft is out-of-balance. • Binding or damaged splines on the driveshaft slip-yoke • Driveshaft runout. • Incorrect lateral and radial tire/wheel runout. • Driveline angles out of specification. • Incorrectly seated CV joint in the front wheel hub. 	<ul style="list-style-type: none"> • CHECK for wear or incorrect seating. INSTALL new U-joints as necessary. REFER to Section 205-00. • CHECK the insulator for damage or wear. ROTATE the driveshaft and CHECK for rough operation. INSTALL a new center bearing support as necessary. Section 205-00. • INSPECT the axle pinion flange. TIGHTEN the pinion flange bolts to specification. REFER to Section 205-00. • CARRY OUT a Runout Check. REPAIR as necessary. REFER to Section 205-00. • CHECK the driveshaft for damage, missing balance weights or undercoating. CHECK driveshaft balance. CARRY OUT a driveline vibration test. REFER to Section 205-00. REPAIR as necessary. • CLEAN and INSPECT the splines of the slip-yoke, driveshaft and coupling shaft for wear or damage. INSTALL a new slip-yoke or driveshaft assembly as necessary. REFER to Section 205-00. REPAIR as necessary. • CARRY OUT a Runout Check. REFER to Section 205-00. REPAIR as necessary. • INSPECT the tire and wheels. MEASURE tire runouts. REPAIR or INSTALL new components as necessary. REFER to Section 204-00. • CHECK for correct driveline angles. REPAIR as necessary. REFER to Section 205-00. • CHECK the outer CV joint for correct seating into the hub. REPAIR as necessary.



BUY IT NOW!
Click Here To Order



DIAGNOSIS AND TESTING (Continued)**Symptom Chart — Engine Noise/Vibration**

Condition	Possible Sources	Action
<ul style="list-style-type: none"> Grinding noise—occurs during engine cranking 	<ul style="list-style-type: none"> Incorrect starter motor mounting. Starter motor. Incorrect starter motor drive engagement. 	<ul style="list-style-type: none"> INSPECT the starter motor for correct mounting. REPAIR as necessary. REFER to Section 303-04A for 4.6L engines or Section 303-04B for 5.4L engines. CHECK the starter motor. REPAIR or INSTALL a new starter motor as necessary. REFER to Section 303-04A for 4.6L engines or Section 303-04B for 5.4L engines. INSPECT the starter motor drive and flywheel/flexplate for wear or damage. INSTALL a new starter motor drive or flywheel/flexplate as necessary. REFER to Section 303-04A for 4.6L engines or Section 303-04B for 5.4L engines.
<ul style="list-style-type: none"> Engine ticking noise 	<ul style="list-style-type: none"> Fuel injector. Fuel line. Oil pump. Valve lifter. Belt tensioner. Water pump. Obstruction of cooling fan. 	<ul style="list-style-type: none"> GO to Pinpoint Test B.
<ul style="list-style-type: none"> Engine drumming noise—normally accompanied by vibration 	<ul style="list-style-type: none"> Powertrain mount. Damaged or misaligned exhaust system. 	<ul style="list-style-type: none"> CARRY OUT Powertrain/Drivetrain Mount Neutralizing in this section. INSPECT the exhaust system for loose or broken clamps and brackets. CARRY OUT Exhaust System Neutralizing in this section.
<ul style="list-style-type: none"> Whistling noise—normally accompanied with poor idle condition 	<ul style="list-style-type: none"> Air intake system. 	<ul style="list-style-type: none"> CHECK the air intake ducts, air cleaner, throttle body and vacuum hoses for leaks and correct fit. REPAIR or ADJUST as necessary. REFER to Section 303-04A for 4.6L engines or Section 303-04B for 5.4L engines.
<ul style="list-style-type: none"> Clunking noise 	<ul style="list-style-type: none"> Water pump has excessive end play or imbalance. Generator has excessive end play. 	<ul style="list-style-type: none"> CHECK the water pump for excessive end play. INSPECT the water pump with the drive belt off for imbalance. INSTALL a new water pump as necessary. REFER to Section 303-03. CHECK the generator for excessive end play. REPAIR or INSTALL a new generator. REFER to Section 414-00.



SATISFACTION 100% GUARANTEED

BUY IT NOW!

Click Here To Order

PayPal American Express Discover MasterCard VISA

DIAGNOSIS AND TESTING (Continued)**Symptom Chart — Engine Noise/Vibration (Continued)**

Condition	Possible Sources	Action
<ul style="list-style-type: none"> Pinging noise 	<ul style="list-style-type: none"> Exhaust system leak. Gasoline octane too low. Knock sensor operation. Incorrect spark timing. High operating temperature. Foul-out spark plug. Catalytic converter. 	<ul style="list-style-type: none"> INSPECT the exhaust system for leaks. REPAIR as necessary. VERIFY with customer the type of gasoline used. CORRECT as necessary. CHECK the knock sensor. INSTALL a new knock sensor as necessary. REFER to Section 303-04A for 4.6L engines or Section 303-04B for 5.4L engines. CHECK the spark timing. REPAIR as necessary. INSPECT cooling system for leaks. CHECK the coolant level. REFILL as necessary. CHECK the coolant for the correct mix ratio. DRAIN and REFILL as needed. CHECK engine operating temperature is within specifications. REPAIR as necessary. CHECK the spark plugs. REPAIR or INSTALL new spark plugs as necessary. Acceptable noise.
<ul style="list-style-type: none"> Knocking noise—light knocking noise, also described as piston slap. Noise is most noticeable when engine is cold with light to medium acceleration. Noise disappears as engine warms 	<ul style="list-style-type: none"> Excessive clearance between the piston and the cylinder wall. 	<ul style="list-style-type: none"> Engine cold and at high idle. Using an EngineEAR, pull a spark plug or fuel injector connector until the noise goes away. CARRY OUT a cylinder bore clearance to piston check. INSTALL a new piston. REFER to Section 303-01A for 4.6L engines or Section 303-01B for 5.4L engines.
<ul style="list-style-type: none"> Knocking noise—light double knock or sharp rap sound. Occurs mostly with warm engine at idle or low speeds in DRIVE. Increases in relation to engine load. Associated with poor lubrication history 	<ul style="list-style-type: none"> Excessive clearance between the piston and the piston pin. 	<ul style="list-style-type: none"> INSTALL a new piston or piston pin. REFER to Section 303-01A for 4.6L engines or Section 303-01B for 5.4L engines.
<ul style="list-style-type: none"> Knocking noise—light knocking noise is most noticeable when engine is warm. Noise tends to decrease when vehicle is coasting or in neutral 	<ul style="list-style-type: none"> Excessive clearance between the connecting rod bearings and the crankshaft. 	<ul style="list-style-type: none"> Engine warm and at idle. Using an EngineEAR, PULL a spark plug or fuel injector connector until the noise goes away. INSTALL new bearings. REFER to Section 303-01A for 4.6L engines or Section 303-01B for 5.4L engines.



BUY IT NOW!

Click Here To Order



DIAGNOSIS AND TESTING (Continued)**Symptom Chart — Engine Noise/Vibration (Continued)**

Condition	Possible Sources	Action
<ul style="list-style-type: none"> Knocking—deep knocking noise. Noise is most noticeable when engine is warm, at lower rpm and under a light load and then at float 	<ul style="list-style-type: none"> Worn or damaged crankshaft main bearings. 	<ul style="list-style-type: none"> CARRY OUT DERU test. CHECK for noise with vehicle at operating temperature, during medium to heavy acceleration. CHECK at idle with injector disconnected, noise does not change. INSTALL new main bearings. REFER to Section 303-01A for 4.6L engines or Section 303-01B for 5.4L engines.
<ul style="list-style-type: none"> Knocking noise—occurs mostly with warm engine at light/medium acceleration 	<ul style="list-style-type: none"> Spark plugs. Carbon accumulation in combustion chamber. 	<ul style="list-style-type: none"> CHECK the spark plug for damage or wear. INSTALL new spark plugs as necessary. REMOVE carbon from combustion chamber.
<ul style="list-style-type: none"> Whine or moaning noise 	<ul style="list-style-type: none"> Air intake system. Generator electrical field or bearings. 	<ul style="list-style-type: none"> CHECK the air cleaner and ducts for correct fit. INSPECT the air intake system for leaks or damage. REPAIR as necessary. CARRY OUT generator load test. REPAIR or INSTALL a new generator as necessary. REFER to Section 414-00.
<ul style="list-style-type: none"> Drone type noise 	<ul style="list-style-type: none"> Exhaust system. A/C compressor. Powertrain mounts. 	<ul style="list-style-type: none"> CARRY OUT Exhaust System Neutralizing in this section. REPAIR as necessary. CHECK for noise with vehicle at constant speeds. CYCLE the compressor on and off and listen for a change in pitch. REPAIR as necessary. REFER to Section 412-00. CARRY OUT Powertrain/Drivetrain Mount Neutralizing in this section.
<ul style="list-style-type: none"> Sputter type noise—noise worse when cold, lessens or disappears when vehicle is at operating temperature 	<ul style="list-style-type: none"> Damaged or worn exhaust system components. 	<ul style="list-style-type: none"> INSPECT the exhaust system for leaks or damage. REPAIR as necessary. REFER to Section 309-00.



DIAGNOSIS AND TESTING (Continued)**Symptom Chart — Engine Noise/Vibration (Continued)**

Condition	Possible Sources	Action
<ul style="list-style-type: none"> Rattling noise—noise from the upper engine (valve train). Worse when engine is cold 	<ul style="list-style-type: none"> Low oil level. Thin or diluted oil. Low oil pressure. Worn rocker arms/fulcrums or followers. Worn valve guides. Excessive runout of valve seats on the valve face. 	<ul style="list-style-type: none"> CHECK oil level. FILL as necessary. INSPECT the oil for contamination. If oil is contaminated, CHECK for the source. REPAIR as necessary. CHANGE the oil and filter. CARRY OUT an oil pressure test. If not within specifications, REPAIR as necessary. REFER to Section 303-00. CARRY OUT a valve train analysis. INSTALL new valve train components as necessary. REFER to Section 303-01A for 4.6L engines or Section 303-01B for 5.4L engines. CARRY OUT a valve train analysis. INSTALL new valve guides as necessary. REFER to Section 303-01A for 4.6L engines or Section 303-01B for 5.4L engines. CARRY OUT a valve seat runout test. INSPECT the valve face and seat. INSTALL new valves as necessary. REFER to Section 303-01A for 4.6L engines or Section 303-01B for 5.4L engines.
<ul style="list-style-type: none"> Rattling noise—from the bottom of the vehicle 	<ul style="list-style-type: none"> Loose muffler shields or catalytic converter shields. 	<ul style="list-style-type: none"> CHECK the exhaust system for loose exhaust shields. REPAIR as necessary.
<ul style="list-style-type: none"> Thumping noise—from the bottom of the vehicle, worse at acceleration 	<ul style="list-style-type: none"> Exhaust pipe/muffler grounded to chassis. 	<ul style="list-style-type: none"> CHECK the exhaust system to chassis clearance. CHECK the exhaust system hangers for damage. REPAIR as necessary. REFER to Section 309-00.
<ul style="list-style-type: none"> Whoosh—occurs during light vehicle acceleration. Heard inside the vehicle 	<ul style="list-style-type: none"> Throttling late, creating turbulence transmitted through the plastic manifold. 	<ul style="list-style-type: none"> CHECK for leaks or missing seal in the dash panel.
<ul style="list-style-type: none"> Engine vibration—increases intensity as engine rpm is increased 	<ul style="list-style-type: none"> Engine out-of-balance. 	<ul style="list-style-type: none"> CARRY OUT Neutral Engine Run-Up (NERU) Test. ROTATE the torque converter, 120° for 3 bolt and 180° for 4 bolt. INSPECT the torque converter pilot outer diameter to crankshaft pilot inner diameter. REPAIR as necessary. REFER to Section 307-01.



BUY IT NOW!

Click Here To Order



DIAGNOSIS AND TESTING (Continued)**Symptom Chart — Engine Noise/Vibration (Continued)**

Condition	Possible Sources	Action
<ul style="list-style-type: none"> Engine vibration—is felt with increases and decreases in engine rpm 	<ul style="list-style-type: none"> Strain on exhaust mounts. Damaged or worn powertrain/drivetrain mounts. Engine or transmission grounded to chassis. 	<ul style="list-style-type: none"> CARRY OUT Exhaust System Neutralizing in this section. REPAIR as necessary. CHECK the powertrain/drivetrain mounts for damage. REFER to Section 303-01A for 4.6L engines or Section 303-01B for 5.4L engines, or Section 307-01. REPAIR as necessary. INSPECT the powertrain/drivetrain for correct clearances. REPAIR as necessary.
<ul style="list-style-type: none"> Engine vibration—vibration felt at all times 	<ul style="list-style-type: none"> Excessive engine pulley runout. Damaged or worn accessory component. 	<ul style="list-style-type: none"> CARRY OUT Engine Accessory Test. INSTALL a new engine pulley as necessary. REFER to Section 303-01A for 4.6L engines or Section 303-01B for 5.4L engines. CARRY OUT Engine Accessory Test. REPAIR or INSTALL a new component as necessary.
<ul style="list-style-type: none"> Accelerator pedal vibration—felt through the pedal as a buzz 	<ul style="list-style-type: none"> Throttle cable loose or misrouted. 	<ul style="list-style-type: none"> INSPECT the throttle cable. REPAIR as necessary. REFER to Section 310-00.
<ul style="list-style-type: none"> Engine vibration—mostly at coast/neutral coast. Condition improves with vehicle accelerating 	<ul style="list-style-type: none"> Combustion instability. 	<ul style="list-style-type: none"> CHECK the ignition system. INSTALL new components as necessary.
<ul style="list-style-type: none"> Engine vibration or shudder—occurs with light to medium acceleration above 56 km/h (35 mph) 	<ul style="list-style-type: none"> Worn or damaged spark plugs. Plugged fuel injector. Damaged spark plug wire. Contaminated fuel. Worn or damaged torque converter. 	<ul style="list-style-type: none"> INSPECT the spark plugs for cracks, high resistance or broken insulator. INSTALL a new spark plug(s) as necessary. REPAIR or INSTALL a new injector as necessary. INSPECT the spark plug wires for damage. INSTALL a new spark plug wire(s) as necessary. INSPECT the fuel for contamination. DRAIN the fuel system and refill. CHECK the torque converter. INSTALL a new torque converter as necessary. REFER to Section 307-01.



BUY IT NOW!

Click Here To Order



DIAGNOSIS AND TESTING (Continued)**Symptom Chart—Idle Noise/Vibration**

Condition	Possible Sources	Action
<ul style="list-style-type: none"> Idle air control (IAC) valve moan — occurs on throttle tip-out 	<ul style="list-style-type: none"> IAC valve is contaminated with oil. 	<ul style="list-style-type: none"> GO to Component Tests in this section.
<ul style="list-style-type: none"> Accessory drive belt chirp — occurs at idle or high idle, cold or hot. Most common occurrence is during humid weather. 	<ul style="list-style-type: none"> Accessory drive belt worn, or pulley is misaligned or loose. 	<ul style="list-style-type: none"> INSPECT for loose or misaligned pulleys. CHECK the drive belt for wear or damage. INSTALL new pulley(s)/accessory drive belt, as necessary. REFER to Section 303-00.
<ul style="list-style-type: none"> Accessory drive bearing hoot — occurs at idle or high idle in cold temperatures of approximately +4°C (+40°F) or colder at first start of the day 	<ul style="list-style-type: none"> Accessory drive idler or tensioner pulley bearing is experiencing stick/slip between ball bearings and bearing race. 	<ul style="list-style-type: none"> GO to Pinpoint Test C.
<ul style="list-style-type: none"> Power steering moan — occurs at high idle and possibly at idle during the first cold start of the day in temperatures of approximately -18°C (0°F) or colder. Noise can even be a severe screech for less than one minute in very cold temperatures of approximately -29°C (-20°F) or colder 	<ul style="list-style-type: none"> High fluid viscosity, or plugged reservoir screen in power steering reservoir starves pump causing cavitation. 	<ul style="list-style-type: none"> GO to Pinpoint Test D.
<ul style="list-style-type: none"> Generator whine — during high electrical loads at idle or high idle, a high pitch whine or moan is emitted from the generator 	<ul style="list-style-type: none"> Generator electrical field noise. 	<ul style="list-style-type: none"> Using an EngineEAR, PROBE near the generator housing. LISTEN for changes in the noise level while changing electrical loads (such as rear defrost, headlamps, etc.). CARRY OUT a generator load test. If the system passes the load test, the noise is from the generator bearings, INSTALL new bearings. If the system fails the load test, INSTALL a new generator. REFER to Section 414-00.
<ul style="list-style-type: none"> Engine-driven cooling fan moan — occurs during the first start of the day. It is most objectionable near idle speeds up to 2000 rpm. The noise increases with rpm 	<ul style="list-style-type: none"> The viscous cooling fan clutch engages until the fluid in the clutch reaches normal operating temperature, causing the fan to fully engage. 	<ul style="list-style-type: none"> GO to Pinpoint Test E.
<ul style="list-style-type: none"> Drumming noise — occurs inside the vehicle during idle or high idle, hot or cold. 	<ul style="list-style-type: none"> Exhaust system vibration excites the body resonances inducing interior noise. Engine vibration excites the body resonances inducing interior noise. 	<ul style="list-style-type: none"> GO to Pinpoint Test F.



BUY IT NOW!

Click Here To Order



DIAGNOSIS AND TESTING (Continued)**Symptom Chart—Idle Noise/Vibration (Continued)**

Condition	Possible Sources	Action
<ul style="list-style-type: none"> Hissing noise — occurs during idle or high idle that is apparent with the hood open 	<ul style="list-style-type: none"> Vacuum leak or idle air control (IAC) valve flow noise. Vehicles with a plastic intake manifold. 	<ul style="list-style-type: none"> Use the Ultrasonic Leak Detector/EngineEAR to locate the source. Scan the air intake system from the inlet to each cylinder intake port. DISCARD the leaking parts, and INSTALL a new component. Acceptable condition. Some plastic manifolds exhibit this noise, which is the effect of the plastic manifold.
<ul style="list-style-type: none"> Automatic transmission buzz or hiss 	<ul style="list-style-type: none"> Incorrect driveline angles. Worn or damaged main control solenoids or valves. 	<ul style="list-style-type: none"> CHECK for correct driveline angles. REPAIR as necessary. REFER to Section 205-00. Using a transmission tester, activate the solenoids to duplicate sound. INSTALL new components as necessary. REFER to Section 307-01.
<ul style="list-style-type: none"> Manual Transmission Clutch throw-out bearing whine. A change in noise pitch or loudness while depressing the clutch pedal 	<ul style="list-style-type: none"> Worn throw-out bearing. 	<ul style="list-style-type: none"> INSTALL a new throw-out bearing.
<ul style="list-style-type: none"> Heating, vacuum and air conditioning (HVAC) system chirp — most audible inside the vehicle. Listen for a change in noise pitch or loudness while changing the HVAC system blower speed 	<ul style="list-style-type: none"> Damaged or worn HVAC blower bearing. 	<ul style="list-style-type: none"> INSTALL a new blower motor. REFER to Section 412-00.
<ul style="list-style-type: none"> Air conditioning (A/C) clutch ticking — occurs when the compressor clutch engages 	<ul style="list-style-type: none"> Acceptable noise. Incorrect air gap. 	<ul style="list-style-type: none"> LISTEN to the clutch to determine if the noise occurs with clutch engagement. A small amount of noise is acceptable. If the noise is excessive, CHECK the A/C clutch air gap. INSPECT the A/C clutch for wear or damage. INSTALL a new clutch as necessary. REFER to Section 412-00.
<ul style="list-style-type: none"> Intermittent rattle, or scraping/rubbing noise 	<ul style="list-style-type: none"> Loose exhaust heat shield(s). Wiring, hose or other part interfering with accessory drive, drive belt or pulley. 	<ul style="list-style-type: none"> INSPECT the exhaust system for loose parts using a glove or clamps to verify cause. REPAIR as necessary. REFER to Section 309-00. INSPECT accessory drive system closely verifying there is adequate clearance to all rotating components. REPAIR as necessary.



BUY IT NOW!

Click Here To Order



DIAGNOSIS AND TESTING (Continued)**Symptom Chart—Idle Noise/Vibration (Continued)**

Condition	Possible Sources	Action
<ul style="list-style-type: none"> Engine ticking or knocking noise — occurs during idle or high idle during the first cold start of the day 	<ul style="list-style-type: none"> Piston noise or valve train noise (bled down lifter/lash adjuster). 	<ul style="list-style-type: none"> GO to Pinpoint Test G.
<ul style="list-style-type: none"> A continuous, speed-dependent rattle from the engine — occurs during idle or high idle during the first cold start of the day and disappears as the engine warms up 	<ul style="list-style-type: none"> Piston noise or valve train noise (bled down lifter/lash adjuster). 	<ul style="list-style-type: none"> GO to Pinpoint Test G.
<ul style="list-style-type: none"> Idle vibration—a low-frequency vibration (5-20 Hz) or mild shake that is felt through the seat/floorpan 	<ul style="list-style-type: none"> Cylinder misfire. Engine or torque converter out of balance. 	<ul style="list-style-type: none"> Using the NGS, CHECK the ignition system. CARRY OUT a cylinder power test. REFER to Section 303-00. VERIFY the torque converter to crankshaft pilot clearance is correct, REPAIR as necessary. RE-INDEX the torque converter on the flex plate by 120° on a 3 bolt converter or 180° for a 4 bolt converter. REFER to Section 307-01. RETEST the vehicle.
<ul style="list-style-type: none"> Idle vibration—a high-frequency vibration (20-80 Hz) or buzz, that is felt through the steering wheel or seat 	<ul style="list-style-type: none"> Exhaust system mounts bound up. Body mounts loose. Power steering lines grounded out. 	<ul style="list-style-type: none"> VERIFY concern occurs at engine firing frequency. CHECK that the exhaust system vibrates at the same frequency as the engine. ADD 9-14 km (20-30 lb.) to the tail pipe to test, CARRY OUT Exhaust System Neutralizing in this section. INSPECT the body mounts. CARRY OUT a Neutral Engine Run-Up (NERU) Test. REPAIR as necessary INSPECT that the power steering lines are not contacting the chassis or each other. REPAIR as necessary.

Symptom Chart—Squeak and Rattle

Condition	Possible Sources	Action
<ul style="list-style-type: none"> Squeak—heard inside the vehicle when closing/opening the door 	<ul style="list-style-type: none"> Insufficient lubrication on the door hinge or check strap. Internal door components loose, rubbing or misaligned. 	<ul style="list-style-type: none"> LUBRICATE the hinge or check strap. CHECK the inside of the door. TIGHTEN or ALIGN as necessary. USE the Rotunda Squeak and Rattle Kit to isolate any rubbing components.
	<ul style="list-style-type: none"> Worn or damaged glass run/channel. 	<ul style="list-style-type: none"> REPAIR or INSTALL a new glass run/channel. REFER to Section 501-00.



BUY IT NOW!
Click Here To Order



DIAGNOSIS AND TESTING (Continued)**Symptom Chart—Squeak and Rattle (Continued)**

Condition	Possible Sources	Action
<ul style="list-style-type: none"> Squeak—heard outside of vehicle when closing/opening the door 	<ul style="list-style-type: none"> Exhaust shield rubbing against the chassis or exhaust pipe. 	<ul style="list-style-type: none"> CHECK the exhaust system. REPAIR as necessary. Section 309-00.
<ul style="list-style-type: none"> Squeak—occurs with initial brake pedal application 	<ul style="list-style-type: none"> Disc brake pads. 	<ul style="list-style-type: none"> Under certain conditions, asbestos free pads can generate a squeak noise. This noise is normal and does not indicate a concern.
<ul style="list-style-type: none"> Squeak—a constant noise that occurs with brake pedal applications 	<ul style="list-style-type: none"> Damaged or worn disc brake pads. 	<ul style="list-style-type: none"> INSPECT the pads for oil, grease or brake fluid contamination. CHECK for glazed linings. A brake disc with hard spots will also cause a squeak type noise. REPAIR or INSTALL new pads as necessary. REFER to Section 206-00 for front disc brakes or rear disc brakes.
<ul style="list-style-type: none"> Squeak—noise occurs over bumps or when turning 	<ul style="list-style-type: none"> Worn control arm bushings. Worn or damaged shock absorber/strut. 	<ul style="list-style-type: none"> INSPECT the control arm bushings. Spray with lubricant and CARRY OUT a “bounce test” to determine which bushing. REPAIR as necessary. REFER to Section 204-00 for 2-wheel drive or 4-wheel drive. INSPECT the shock absorber for damage. CARRY OUT a “bounce test” to isolate the noise. INSTALL a new shock absorber/strut as necessary. REFER to Section 204-00 for the front shock absorber/strut or rear shock absorber/strut.
<ul style="list-style-type: none"> Rattle—heard when closing/opening the door or window 	<ul style="list-style-type: none"> Loose internal door mechanism, bracket or attachment. 	<ul style="list-style-type: none"> REPEAT the motion or CARRY OUT a “tap test” to duplicate the noise. INSPECT the door for loose components. TIGHTEN loose components or USE the Rotunda Squeak and Rattle Kit to isolate any rattling components.



BUY IT NOW!
Click Here To Order



DIAGNOSIS AND TESTING (Continued)**Symptom Chart—Squeak and Rattle (Continued)**

Condition	Possible Sources	Action
<ul style="list-style-type: none"> Squeak or rattle—heard inside the vehicle over rough roads/bumps 	<ul style="list-style-type: none"> Misaligned glove compartment door/hinge. Instrument panel trim loose or misaligned. Loose interior component or trim. 	<ul style="list-style-type: none"> ALIGN the glove compartment door. INSPECT the instrument panel trim for missing or loose clips or screws. REPAIR as necessary. CARRY OUT a “touch test”. ELIMINATE the noise by pressing or pulling on interior trim and components. USE the Rotunda Squeak and Rattle Kit to isolate any rattling/squeaking components.
<ul style="list-style-type: none"> Squeak or rattle—noise with a vibration concern 	<ul style="list-style-type: none"> Damaged or worn body mounts. Damaged or worn sub-frame mounts. 	<ul style="list-style-type: none"> INSPECT the upper and lower absorbers and washers for damage or wear. CHECK the body mount brackets for damage. CHECK the nuts and bolts are tightened to specifications. TIGHTEN as necessary. INSPECT the upper and lower absorbers for damage or wear. CHECK the sub-frame for damage. CHECK the nuts and bolts are tightened to specifications. TIGHTEN as necessary.

Symptom Chart—Steering Noise/Vibration

Condition	Possible Sources	Action
<ul style="list-style-type: none"> Steering grunt or shudder — occurs when turning into or out of a turn at low speeds (temperature sensitive) 	<ul style="list-style-type: none"> Steering gear or power steering hoses. 	<ul style="list-style-type: none"> GO to Steering Gear Grunt/Shudder Test component test in this section.
<ul style="list-style-type: none"> Steering System clonk—hydraulic knocking sound 	<ul style="list-style-type: none"> Air in the steering hydraulic system. 	<ul style="list-style-type: none"> CHECK for leaks in the system. PURGE the air from the system. REFER to Section 211-00.



DIAGNOSIS AND TESTING (Continued)**Symptom Chart—Steering Noise/Vibration (Continued)**

Condition	Possible Sources	Action
<ul style="list-style-type: none"> Power steering pump moan — loud humming noise occurs when the steering wheel is rotated to the stop position. Produces a 120-600 Hz frequency that changes with rpm 	<ul style="list-style-type: none"> Power steering hose grounded out to chassis. Aerated fluid. Steering gear isolators. Low fluid. Power steering pump brackets loose or misaligned. 	<ul style="list-style-type: none"> INSPECT the power steering hoses. REPAIR as necessary. CHECK for leaks in the system. PURGE the air from the system. REFER to Section 211-00. INSPECT the isolators for wear or damage. REPAIR as necessary. CHECK the fluid level. REFILL as necessary. CHECK bolts, brackets and bracket alignment. TIGHTEN bolts to specification. REPAIR or INSTALL new brackets as necessary. REFER to Section 211-00.
<ul style="list-style-type: none"> Steering gear clunk — occurs only while cornering over a bump (can be temperature sensitive) 	<ul style="list-style-type: none"> Steering gear. 	<ul style="list-style-type: none"> INSPECT the steering gear for loose mounting bolts. TIGHTEN as necessary. REFER to Section 211-00.
<ul style="list-style-type: none"> Feedback (rattle, chuckle or knocking noise in the steering gear) — a condition where roughness is felt in the steering wheel when the vehicle is driven over rough surfaces 	<ul style="list-style-type: none"> Column intermediate/flexible shaft joints damaged or worn. Loose, damaged or worn tie-rod ends. Steering gear insulators or mounting bolts loose or damaged. Steering column intermediate shaft bolts are loose. Steering column damaged or worn. Loose suspension bushings, bolts or ball joints. 	<ul style="list-style-type: none"> INSTALL a new intermediate/flexible shaft. REFER to Section 211-00. TIGHTEN the nuts to specification or INSTALL new tie-rod ends as necessary. REFER to Section 211-00. TIGHTEN the bolts or INSTALL new bolts as necessary. REFER to Section 211-00. TIGHTEN the bolts to specification. REFER to Section 211-00. REPAIR or INSTALL a new steering column as necessary. REFER to Section 211-00. INSPECT the suspension system. TIGHTEN or INSTALL new components as necessary. REFER to Section 204-00 for 2-wheel drive or 4-wheel drive.



BUY IT NOW!

Click Here To Order



DIAGNOSIS AND TESTING (Continued)**Symptom Chart—Steering Noise/Vibration (Continued)**

Condition	Possible Sources	Action
<ul style="list-style-type: none"> Feedback (nibble at the steering wheel) — a condition where slight rotational movement is felt in the steering wheel when the vehicle is driven over rough or grooved surfaces 	<ul style="list-style-type: none"> Lateral runout in the tire or wheel. Yoke spring in the steering gear. 	<ul style="list-style-type: none"> GO to Pinpoint Test H. CHECK TSBs for revised yoke spring for applicable vehicles.
<ul style="list-style-type: none"> Accessory drive belt squeal/chirp—when rotating the steering wheel from stop to stop 	<ul style="list-style-type: none"> Loose or worn accessory drive belt. 	<ul style="list-style-type: none"> ADJUST or INSTALL a new accessory drive belt as necessary. REFER to Section 303-00.
<ul style="list-style-type: none"> Power steering gear hiss 	<ul style="list-style-type: none"> Steering column intermediate/flexible shaft-to-steering gear is binding or misaligned. Grounded or loose steering column boot at the dash panel. Damaged or worn steering gear input shaft and valve. 	<ul style="list-style-type: none"> REPAIR or INSTALL a new intermediate/flexible shaft as necessary. REFER to Section 211-00. REPAIR as necessary. REPAIR or INSTALL a new steering gear as necessary. REFER to Section 211-00.
<ul style="list-style-type: none"> Steering column rattle 	<ul style="list-style-type: none"> Loose bolts or attaching brackets. Loose, worn or insufficiently lubricated column bearings. Steering shaft insulators damaged or worn. Intermediate/flexible shaft compressed or extended. 	<ul style="list-style-type: none"> TIGHTEN the bolts to specifications. LUBRICATE or INSTALL new steering column bearings as necessary. REFER to Section 211-00. INSTALL new insulators. REFER to Section 211-00. INSPECT the rubber spider coupling for damage. INSTALL a new intermediate/flexible shaft. REFER to Section 211-00.
<ul style="list-style-type: none"> Steering column squeak or cracks 	<ul style="list-style-type: none"> Insufficient lubricated steering shaft bushings. Loose or misaligned steering column shrouds. Steering wheel rubbing against steering column shrouds. Insufficient lubricated speed control slip ring. Upper or lower bearing sleeve out of position. 	<ul style="list-style-type: none"> LUBRICATE the steering shaft and shaft tube seals. TIGHTEN or ALIGN the steering column shrouds. REPOSITION the steering column shrouds. LUBRICATE the speed control slip ring. REPOSITION the bearing sleeves.



100% SATISFACTION GUARANTEED

BUY IT NOW!

Click Here To Order

PayPal American Express Discover MasterCard VISA

DIAGNOSIS AND TESTING (Continued)**Symptom Chart—Steering Noise/Vibration (Continued)**

Condition	Possible Sources	Action
<ul style="list-style-type: none"> Power steering pump noisy 	<ul style="list-style-type: none"> Incorrect assembly of components. Imperfections on the outside diameter or end surface of the power steering pump rotor. Damaged or worn power steering pump rotor splines. A crack on the inner surface of the power steering pump cam. Interference between the power steering pump rotor and cam. Damaged or worn power steering pump rotor and pressure plates. 	<ul style="list-style-type: none"> REPAIR or INSTALL a new power steering pump as necessary. REFER to Section 211-00.
<ul style="list-style-type: none"> Power steering pump swish noise 	<ul style="list-style-type: none"> Power steering fluid flow into the bypass valve of the pump valve housing with fluid temperature below 54°C (130°F). 	<ul style="list-style-type: none"> Acceptable condition.
<ul style="list-style-type: none"> Power steering pump whine noise 	<ul style="list-style-type: none"> Aerated fluid. Damaged power steering pump cam. Damaged valve cover O-ring seal. 	<ul style="list-style-type: none"> CHECK for a leak in the system. PURGE the air from the system. REFER to Section 211-00. REPAIR or INSTALL a new power steering pump as necessary. REFER to Section 211-00. REPAIR or INSTALL a new power steering pump as necessary. REFER to Section 211-00.
<ul style="list-style-type: none"> Power steering pump clicking (mechanical) noise 	<ul style="list-style-type: none"> Power steering pump rotor slippers too long, excessive rotor slipper-to-slot clearance or damaged or worn rotor assembly. 	<ul style="list-style-type: none"> REPAIR or INSTALL a new power steering pump as necessary. REFER to Section 211-00.
<ul style="list-style-type: none"> Power steering pump clatter noise 	<ul style="list-style-type: none"> Damaged corners on the outside diameter or the power steering rotor or distorted rotor slipper ring. 	<ul style="list-style-type: none"> REPAIR or INSTALL a new power steering pump as necessary. REFER to Section 211-00.



DIAGNOSIS AND TESTING (Continued)**Symptom Chart—Suspension Noise/Vibration**

Condition	Possible Sources	Action
<ul style="list-style-type: none"> Squeak or grunt—noise from the front suspension, occurs more in cold ambient temperatures. More noticeable over rough roads or when turning 	<ul style="list-style-type: none"> Front stabilizer bar insulators. 	<ul style="list-style-type: none"> Under these conditions, the noise is acceptable. CHECK TSBs.
<ul style="list-style-type: none"> Clunk—noise from the front suspension, occurs in and out of turns 	<ul style="list-style-type: none"> Loose front struts or shocks. 	<ul style="list-style-type: none"> INSPECT for loose nuts or bolts. TIGHTEN to specifications. REFER to Section 204-00 for 2-wheel drive vehicles or 4-wheel drive vehicles.
<ul style="list-style-type: none"> Clunk—noise from the rear suspension, occurs when shifting from reverse to drive 	<ul style="list-style-type: none"> Loose rear suspension components. 	<ul style="list-style-type: none"> INSPECT for loose or damaged rear suspension components. REPAIR or INSTALL new components as necessary. REFER to Section 204-00.
<ul style="list-style-type: none"> Click or pop—noise from the front suspension. More noticeable over rough roads or over bumps 	<ul style="list-style-type: none"> Worn or damaged ball joints. 	<ul style="list-style-type: none"> CARRY OUT a ball joint inspection. INSTALL new ball joints or control arms as necessary. REFER to Section 204-00 for 2-wheel drive vehicles or 4-wheel drive vehicles.
<ul style="list-style-type: none"> Click or pop (FWD vehicles)—noise occurs when vehicle is turning 	<ul style="list-style-type: none"> Worn or damaged ball joints. 	<ul style="list-style-type: none"> CARRY OUT a ball joint inspection. INSTALL new ball joints or control arms as necessary.
<ul style="list-style-type: none"> Click or snap—occurs when accelerating around a corner 	<ul style="list-style-type: none"> Damaged or worn outboard CV joint. 	<ul style="list-style-type: none"> INSPECT the outboard CV joint and boot. REPAIR or INSTALL a new CV joint as necessary.
<ul style="list-style-type: none"> Front suspension noise—a squeak, creak or rattle noise. Occurs mostly over bumps or rough roads 	<ul style="list-style-type: none"> Steering components. Loose or bent front struts or shock absorbers. Damaged spring or spring mounts. Damaged or worn control/radius arm bushings. Worn or damaged stabilizer bar bushings or links. 	<ul style="list-style-type: none"> GO to Pinpoint Test H.
<ul style="list-style-type: none"> Rear suspension noise—a squeak, creak or rattle noise. Occurs mostly over bumps or rough roads 	<ul style="list-style-type: none"> Loose or bent rear shock absorbers. Damaged spring or spring mounts. Damaged or worn control arm bushings. Worn or damaged stabilizer bar bushings or links. 	<ul style="list-style-type: none"> GO to Pinpoint Test I.



BUY IT NOW!

Click Here To Order



DIAGNOSIS AND TESTING (Continued)**Symptom Chart—Suspension Noise/Vibration (Continued)**

Condition	Possible Sources	Action
<ul style="list-style-type: none"> Shudder—occurs during acceleration from a slow speed or stop 	<ul style="list-style-type: none"> Rear drive axle assembly mispositioned. Incorrect or high CV joint operating angle. Damaged or worn front suspension components. 	<ul style="list-style-type: none"> CHECK the axle mounts and the rear suspension for damage or wear. REPAIR as necessary. CHECK vehicle ride height is within limits. REPAIR as necessary. CHECK for a loose stabilizer bar, damaged or loose strut/strut bushings or loose or worn ball joints. INSPECT the steering linkage for wear or damage. REPAIR or INSTALL new components as necessary.
<ul style="list-style-type: none"> Shimmy—most noticeable on coast/deceleration. Also hard steering condition 	<ul style="list-style-type: none"> Excessive positive caster. 	<ul style="list-style-type: none"> CHECK the caster alignment angle. CORRECT as necessary. REFER to Section 204-00.

Symptom Chart—Tire Noise/Vibration

Condition	Possible Sources	Action
<ul style="list-style-type: none"> Tire noise—hum/moan at constant speeds 	<ul style="list-style-type: none"> Abnormal wear patterns. 	<ul style="list-style-type: none"> SPIN the tire and CHECK for tire wear. INSTALL a new tire as necessary. INSPECT for damaged/worn suspension components. CARRY OUT wheel alignment.
<ul style="list-style-type: none"> Tire noise—noise tone lowers as the vehicle speed is lowered 	<ul style="list-style-type: none"> Out-of-balance tire. 	<ul style="list-style-type: none"> BALANCE the tire and road test. INSTALL a new tire as necessary. REFER to Section 204-00.
<ul style="list-style-type: none"> Tire noise — ticking noise, changes with speed 	<ul style="list-style-type: none"> Nail puncture or stone in tire tread. 	<ul style="list-style-type: none"> INSPECT the tire. REPAIR as necessary.
<ul style="list-style-type: none"> Wheel and tire—vibration and noise concern is directly related to vehicle speed and is not affected by acceleration, coasting or decelerating 	<ul style="list-style-type: none"> Damaged or worn tire. 	<ul style="list-style-type: none"> GO to Pinpoint Test J.



DIAGNOSIS AND TESTING (Continued)**Symptom Chart—Tire Noise/Vibration (Continued)**

Condition	Possible Sources	Action
<ul style="list-style-type: none"> Tire wobble or shudder — occurs at lower speeds 	<ul style="list-style-type: none"> Damaged wheel bearings. Damaged wheel. Damaged or worn suspension components. Loose wheel nuts. Damaged or uneven tire wear. 	<ul style="list-style-type: none"> SPIN the tire and CHECK for abnormal wheel bearing play or roughness. ADJUST or INSTALL new wheel bearings as necessary. REFER to Section 204-00 for 2-wheel drive vehicles or 4-wheel drive vehicles. INSPECT the wheel for damage. INSTALL a new wheel as necessary. REFER to Section 204-00 for 2-wheel drive vehicles or 4-wheel drive vehicles. INSPECT the suspension components for wear or damage. REPAIR as necessary. CHECK the wheel nuts. TIGHTEN to specification. REFER to Section 204-00. SPIN the tire and CHECK for abnormal tire wear or damage. INSTALL a new tire as necessary. REFER to Section 204-00.
<ul style="list-style-type: none"> Tire shimmy or shake— occurs at lower speeds 	<ul style="list-style-type: none"> Wheel/tire out of balance. Uneven tire wear. Excessive radial runout of wheel or tire. Worn or damaged wheel studs or elongated stud holes. Excessive lateral runout of the wheel or tire. Foreign material between the brake disc and hub or in the brake disc fins. 	<ul style="list-style-type: none"> BALANCE the wheel/tire assembly. CHECK for abnormal tire wear. INSTALL a new tire as necessary. REFER to Section 204-00. CARRY OUT a radial runout test of the wheel and tire. INSTALL a new tire as necessary. REFER to Section 204-00. INSPECT the wheel studs and wheels. INSTALL new components as necessary. REFER to Section 204-00. CARRY OUT a lateral runout test of the wheel and tire. CHECK the wheel, tire and hub. REPAIR or INSTALL new components as necessary. CLEAN the mounting surfaces of the brake disc and hub. CHECK the brake disc fins for material.



SATISFACTION 100% GUARANTEED

BUY IT NOW!

Click Here To Order

PayPal American Express Discover MasterCard VISA

DIAGNOSIS AND TESTING (Continued)**Symptom Chart—Tire Noise/Vibration (Continued)**

Condition	Possible Sources	Action
<ul style="list-style-type: none"> High speed shake or shimmy—occurs at high speeds 	<ul style="list-style-type: none"> Excessive wheel hub runout. Damaged or worn tires. Damaged or worn wheel bearings. Worn or damaged suspension or steering linkage components. Brake disc or drum imbalance. 	<ul style="list-style-type: none"> GO to Pinpoint Test K.

Symptom Chart—Transmission (Manual) and Transfer Case Noise/Vibration

Condition	Possible Sources	Action
<ul style="list-style-type: none"> Clutch rattling noise—occurs with clutch engaged, noise changes/disappears with clutch pedal depressed 	<ul style="list-style-type: none"> Flywheel bolts, clutch housing bolts or clutch pressure plate bolts loose. 	<ul style="list-style-type: none"> TIGHTEN the bolts to specifications. CHECK the bolts for damage.
<ul style="list-style-type: none"> Clutch squeaking noise—noise is heard when the clutch is operated. Vehicle moves slowly or creeps when the clutch is disengaged. Can also be difficult to shift into first and reverse gear 	<ul style="list-style-type: none"> Pilot bearing seized or damaged. 	<ul style="list-style-type: none"> INSTALL a new pilot bearing.
<ul style="list-style-type: none"> Clutch squeaking noise—occurs with clutch pedal depressed/released 	<ul style="list-style-type: none"> Worn clutch pedal shaft or bushings. 	<ul style="list-style-type: none"> INSPECT the clutch pedal for wear or damage. REPAIR as necessary.
<ul style="list-style-type: none"> Clutch whirring/rattle noise—occurs when clutch pedal is depressed 	<ul style="list-style-type: none"> Worn, damaged or misaligned clutch release bearing. 	<ul style="list-style-type: none"> INSTALL a new clutch release bearing.
<ul style="list-style-type: none"> Clutch grating/grinding noise—occurs when clutch pedal is depressed 	<ul style="list-style-type: none"> Clutch pressure plate fingers bent or worn. Contact surface of clutch release bearing worn or damaged. 	<ul style="list-style-type: none"> INSPECT the clutch pressure plate release fingers. INSTALL a new pressure plate as necessary. INSTALL a new clutch release bearing.
<ul style="list-style-type: none"> Clutch chatter—a small amount of noise when clutch pedal is released at initial take-off 	<ul style="list-style-type: none"> Clutch engagement. 	<ul style="list-style-type: none"> Acceptable operating condition.

100% SATISFACTION GUARANTEED

BUY IT NOW!

Click Here To Order

PayPal American Express Discover MasterCard VISA

DIAGNOSIS AND TESTING (Continued)**Symptom Chart—Transmission (Manual) and Transfer Case Noise/Vibration (Continued)**

Condition	Possible Sources	Action
<ul style="list-style-type: none"> Clutch chatter/grabs—in some cases a shudder is felt. Occurs with clutch pedal depressed/released 	<ul style="list-style-type: none"> Damaged or worn powertrain/driveline mounts. Binding or dragging plunger of the clutch master cylinder or slave cylinder. Grease or oil on the clutch disc facing. Clutch disc surface glazed or damaged. Damaged or worn clutch pressure plate. Flywheel surface damaged or glazed. 	<ul style="list-style-type: none"> INSPECT the powertrain/drivetrain mounts. INSTALL new mounts as necessary. CHECK the master and slave cylinder operation. INSPECT the components for damage or wear. INSTALL a new master or slave cylinder as necessary. CHECK the input shaft seal and rear main oil seal. REPAIR as necessary. INSTALL a new clutch disc. INSPECT the clutch disc surface for a glazed, hardened or damage condition. CARRY OUT a disc check. INSTALL a new clutch disc as necessary. INSPECT the clutch pressure plate for wear or damage. INSTALL a new clutch pressure plate as necessary. INSPECT the flywheel for damage or wear. CARRY OUT a flywheel runout check. INSTALL a new flywheel as necessary.
<ul style="list-style-type: none"> Clutch chatter noise—noise when clutch pedal is released at initial take-off. Clutch is hard to engage and disengage 	<ul style="list-style-type: none"> Pilot bearing worn, damaged or not correctly aligned in bore. 	<ul style="list-style-type: none"> INSPECT the clutch pressure plate release fingers for uneven wear, clutch components burnt or a seized pilot bearing. INSTALL a new pilot bearing as necessary.
<ul style="list-style-type: none"> Clutch vibration 	<ul style="list-style-type: none"> Loose flywheel bolts. Damaged or loose clutch pressure plate. Excessive flywheel runout. 	<ul style="list-style-type: none"> GO to Pinpoint Test L.
<ul style="list-style-type: none"> Transmission rattling/clattering noise—noise at idle or on light acceleration from a stop. Gear selection difficult 	<ul style="list-style-type: none"> Gearshift lever joint worn or damaged. Gearshift lever loose. Gearshift linkage rods worn or damaged. 	<ul style="list-style-type: none"> INSTALL a new gearshift lever. TIGHTEN the bolts to specification. CHECK the linkage bushings for wear. INSTALL new linkage rods as necessary. REFER to the appropriate workshop manual for the service procedures.
	<ul style="list-style-type: none"> Incorrect fluid level or fluid quality. 	<ul style="list-style-type: none"> CHECK that the transmission is filled to the correct level and with the specified fluid.



BUY IT NOW!

Click Here To Order



DIAGNOSIS AND TESTING (Continued)**Symptom Chart—Transmission (Manual) and Transfer Case Noise/Vibration (Continued)**

Condition	Possible Sources	Action
<ul style="list-style-type: none"> Transmission rattling/clattering noise—noise at idle in neutral 	<ul style="list-style-type: none"> Worn or rough reverse idler gear. Rough running engine, cylinder misfire. Excessive backlash in gears. Worn countershaft gears. 	<ul style="list-style-type: none"> CHECK the reverse idler gear. REPAIR as necessary. CHECK the ignition system. CARRY OUT a cylinder power test. REPAIR as necessary. CHECK the gear backlash. ADJUST as necessary. REPAIR as necessary.
<ul style="list-style-type: none"> Transmission whine—a mild whine at extreme speeds or high rpm 	<ul style="list-style-type: none"> Rotating gears/geartrain. 	<ul style="list-style-type: none"> Acceptable noise.
<ul style="list-style-type: none"> Transmission whine—a high pitched whine, also described as a squeal 	<ul style="list-style-type: none"> Transmission gears are worn (high mileage vehicle). Mismatched gear sets. Damaged or worn transmission bearing. 	<ul style="list-style-type: none"> Result of normal gear wear. REPAIR as necessary. INSPECT the gear sets for an uneven wear pattern on the face of the gear teeth. REPAIR as necessary. INSPECT the transmission bearings. INSTALL new bearings as necessary.
<ul style="list-style-type: none"> Transmission growling/humming—noise occurs in the forward gears. The noise is more prominent when the gear is loaded. The problem gear can be located as the noise occurs in a specific gear position 	<ul style="list-style-type: none"> Gear is cracked, chipped or rough. 	<ul style="list-style-type: none"> INSPECT the transmission gears for damage or wear. INSTALL new gears as necessary.
<ul style="list-style-type: none"> Transmission hissing—noise in neutral or in forward gears. As bearings wear or break up, the noise changes to a thumping noise 	<ul style="list-style-type: none"> Damaged or worn bearings. 	<ul style="list-style-type: none"> INSPECT the transmission bearings. INSTALL new bearings as necessary.
<ul style="list-style-type: none"> Transmission knocking/thudding—noise at low speeds in forward gears 	<ul style="list-style-type: none"> Bearings with damaged balls or rollers or with pitted and spalled races. 	<ul style="list-style-type: none"> INSPECT the transmission bearings. INSTALL new bearings as necessary.
<ul style="list-style-type: none"> Transmission rumble/growl—noise at higher speeds in forward gears, more pronounced in a coast/deceleration condition 	<ul style="list-style-type: none"> Incorrect driveline angle. Driveshaft out of balance or damaged. 	<ul style="list-style-type: none"> CHECK the driveline angle. REPAIR as necessary. REFER to Section 205-00. CHECK the driveshaft for damage, missing balance weights or undercoating. Using the vibration analyzer (VA), CHECK the driveshaft balance. CARRY OUT a driveline vibration test. For additional information, REFER to Section 205-00. REPAIR as necessary.



BUY IT NOW!

Click Here To Order



DIAGNOSIS AND TESTING (Continued)**Symptom Chart—Transmission (Manual) and Transfer Case Noise/Vibration (Continued)**

Condition	Possible Sources	Action
<ul style="list-style-type: none"> Transmission rumble/growl—noise at all speeds in forward gears, more pronounced in a heavy acceleration condition 	<ul style="list-style-type: none"> Damaged or worn transmission bearing or gears (high mileage vehicles). 	<ul style="list-style-type: none"> CHECK transmission fluid for excessive metal particles. REPAIR as necessary.
<ul style="list-style-type: none"> Transfer case whine—noise at all ranges 	<ul style="list-style-type: none"> Incorrect fluid level or fluid quality. Worn oil pump. Under-inflated or oversized tires. 	<ul style="list-style-type: none"> CHECK that the transfer case is filled to the correct level and with the specified fluid. REFER to Section 308-07. DISASSEMBLE the transfer case. CHECK the oil pump for wear or damage. REPAIR as necessary. REFER to Section 308-07. CONFIRM that the tires and wheels are correct for the vehicle. CHECK that the tire inflation pressures are correct.
<ul style="list-style-type: none"> Transfer case growl/rumble—noise at all ranges (A small amount of planetary noise can be heard when the transfer case is operated in low range.) 	<ul style="list-style-type: none"> Damaged or worn bearings or planetary gear. 	<ul style="list-style-type: none"> DISASSEMBLE the transfer case. CHECK the bearings or planetary gear for wear or damage. REPAIR as necessary. REFER to Section 308-07.
<ul style="list-style-type: none"> Transfer case scraping/grating—noise at all ranges 	<ul style="list-style-type: none"> Excessively stretched drive chain hitting the case. 	<ul style="list-style-type: none"> DISASSEMBLE the transfer case. CHECK the drive chain for wear or damage. REPAIR as necessary. REFER to Section 308-07.
<ul style="list-style-type: none"> Transfer case howl/hum—noise at all ranges or high range only 	<ul style="list-style-type: none"> Worn or damaged sun (input) gear, clutch pack (intermediate) gear or output shaft gear. 	<ul style="list-style-type: none"> DISASSEMBLE the transfer case. CHECK the gears for wear or damage. REPAIR as necessary. REFER to Section 308-07.
<ul style="list-style-type: none"> Transfer case howl/hum—noise at low range only 	<ul style="list-style-type: none"> Worn or damaged intermediate gear and sliding gears (clutch pack). 	<ul style="list-style-type: none"> DISASSEMBLE the transfer case. CHECK the gears for wear or damage. REPAIR as necessary. REFER to Section 308-07.
<ul style="list-style-type: none"> Transfer case vibration—vibration felt with vehicle in 4WD 	<ul style="list-style-type: none"> Transfer case mounting. Driveshaft out of balance. Excessive pinion flange runout. 	<ul style="list-style-type: none"> GO to Pinpoint Test M.



BUY IT NOW!

Click Here To Order 







DIAGNOSIS AND TESTING (Continued)**Symptom Chart—Transmission (Automatic) Noise/Vibration**

Condition	Possible Sources	Action
<ul style="list-style-type: none"> Rattle—occurs at idle or at light acceleration from a stop 	<ul style="list-style-type: none"> Damaged engine or transmission mounts. A loose front exhaust pipe heat shield. Loose inspection plate or dust cover plate. Loose flexplate to converter nuts. 	<ul style="list-style-type: none"> CHECK the powertrain/drivetrain mounts for damage. INSTALL new mounts as necessary. REFER to Section 303-01A for 4.6L engines, Section 303-01B for 5.4L engines or Section 307-01. REPAIR or INSTALL a new heat shield as necessary. CHECK for loose bolts. TIGHTEN to specifications. REFER to Section 307-01. CHECK for loose nuts. TIGHTEN to specifications. REFER to Section 307-01.
<ul style="list-style-type: none"> Whine—pitch increases with vehicle speed. Starts in first and second gear, decreases or goes away at higher gears 	<ul style="list-style-type: none"> Damaged or worn low one-way clutch. Damaged or worn intermediate one-way clutch. Friction elements. Damaged or worn planetary or sun gear. 	<ul style="list-style-type: none"> INSPECT the transmission for wear or damage. REPAIR or INSTALL new components as necessary. REFER to Section 307-01.
<ul style="list-style-type: none"> Whine—the pitch changes with engine speed 	<ul style="list-style-type: none"> A worn or damaged accessory drive component. Incorrect fluid level. Partially blocked filter. Worn or damaged torque converter. Worn or damaged front pump. 	<ul style="list-style-type: none"> CARRY OUT the Engine Accessory Test. REPAIR or INSTALL new components as necessary. CHECK that the transmission is filled to the correct level. ADD fluid as necessary. REFER to Section 307-01. INSPECT the filter. CLEAN or INSTALL a new filter as necessary. REFER to Section 307-01. CARRY OUT the torque converter service and replacement check. REFER to Section 307-01. INSPECT the front pump. INSTALL a new front pump as necessary. REFER to Section 307-01.
<ul style="list-style-type: none"> Whine—pitch changes with vehicle speed 	<ul style="list-style-type: none"> Speedometer cable or gears. 	<ul style="list-style-type: none"> REPAIR or INSTALL new cables or gears as necessary.



SATISFACTION 100% GUARANTEED

BUY IT NOW!

Click Here To Order

PayPal American Express Discover MasterCard VISA

DIAGNOSIS AND TESTING (Continued)**Symptom Chart—Transmission (Automatic) Noise/Vibration (Continued)**

Condition	Possible Sources	Action
<ul style="list-style-type: none"> Whine/moan type noise—pitch increases or changes with vehicle speed 	<ul style="list-style-type: none"> Damaged engine or transmission mount. U-joints worn or damaged. Damaged or worn differential ring and pinion. Planetary gears nicked or chipped. 	<ul style="list-style-type: none"> CHECK the powertrain/drivetrain mounts for damage. REFER to Section 303-01A for 4.6L engines, Section 303-01B for 5.4L engines or Section 307-01. INSPECT the U-joints for wear or damage. INSTALL new U-joints as necessary. REFER to Section 205-00. INSPECT the differential ring and pinion for damage. CARRY OUT the Checking Tooth Contact Pattern and Condition of the Ring and Pinion component test in this section. REPAIR or INSTALL a new differential ring and pinion as necessary. REFER to Section 205-00 for the rear drive axle or front drive axle. CHECK the planetary gears for damage. INSTALL new components as necessary. REFER to Section 307-01.
<ul style="list-style-type: none"> Whistle—noise is high pitched, constant. Changes in pitch with throttle position 	<ul style="list-style-type: none"> Hydraulic pressure in the main control. Incorrect band/clutch apply pressure. Worn or damaged torque converter. 	<ul style="list-style-type: none"> INSPECT the main control. REPAIR or INSTALL new components as necessary. REFER to Section 307-01. CARRY OUT the line pressure tests. REPAIR or INSTALL components as necessary. REFER to Section 307-01. CARRY OUT the torque converter service and replacement check. REFER to Section 307-01.



BUY IT NOW!
Click Here To Order 







DIAGNOSIS AND TESTING (Continued)**Symptom Chart—Transmission (Automatic) Noise/Vibration (Continued)**

Condition	Possible Sources	Action
<ul style="list-style-type: none"> Clunk—occurs when shifting from PARK to a drive or reverse position 	<ul style="list-style-type: none"> Damaged powertrain mounts. Damaged or worn pinion bearings. Worn or galled driveshaft slip yoke splines. Worn friction elements or excessive clutch pack end plate play. 	<ul style="list-style-type: none"> INSPECT the powertrain mounts for damage. INSTALL new mounts as necessary. CHECK for abnormal bearing play or roughness. INSTALL new bearings as necessary. REFER to Section 205-00 for the rear drive axle or front drive axle. CLEAN and INSPECT the splines of the yoke. INSTALL a new slip yoke as necessary. REFER to Section 205-00. INSPECT the transmission for wear. CHECK that all end play and clearances are within specification. REPAIR or INSTALL new components as necessary. REFER to Section 307-01.
<ul style="list-style-type: none"> Bump—occurs when shifting from PARK to a drive or reverse position. Similar to Clunk but with no sound 	<ul style="list-style-type: none"> Initial gear engagement. 	<ul style="list-style-type: none"> Acceptable condition.
<ul style="list-style-type: none"> Buzz or hiss 	<ul style="list-style-type: none"> Incorrect driveline angles. Worn or damaged main control solenoids or valves. 	<ul style="list-style-type: none"> CHECK for correct driveline angles. REPAIR as necessary. REFER to Section 205-00. Using a transmission tester, ACTIVATE the solenoids to duplicate sound. INSTALL new components as necessary. REFER to Section 307-01.
<ul style="list-style-type: none"> Vibration—a high frequency (20-80 Hz) that is felt through the seat or gear shifter. Changes with engine speed 	<ul style="list-style-type: none"> Transmission cooler lines grounded out. Flexplate to torque converter nuts loose. Fluid filler tube grounded out. Shift cable incorrectly routed, grounded out or loose. 	<ul style="list-style-type: none"> CHECK the transmission cooler lines. REPAIR as necessary. CHECK the flexplate nuts. TIGHTEN to specification. REFER to Section 307-01. CHECK the fluid filler tube. REPAIR as necessary. CHECK the shift cable. REPAIR as necessary. Section 307-01.



100% SATISFACTION GUARANTEED

BUY IT NOW!

Click Here To Order

PayPal American Express Discover MasterCard VISA

DIAGNOSIS AND TESTING (Continued)

Symptom Chart—Transmission (Automatic) Noise/Vibration (Continued)

Condition	Possible Sources	Action
<ul style="list-style-type: none"> Shutter or chatter—occurs with light to medium acceleration from low speeds or a stop 	<ul style="list-style-type: none"> Electrical inputs/outputs. Vehicle wiring harness. Incorrect inputs/outputs from the powertrain control module (PCM), digital transmission range (TR) sensor, brake pedal position (BPP) sensor, throttle position (TP) sensor, transmission speed sensor (TSS), output speed shaft (OSS) sensor or the torque converter clutch (TCC). 	<ul style="list-style-type: none"> CARRY OUT a Torque Converter Clutch Operation Test. RUN on-board diagnostics or self-test. REFER to Section 307-01. CLEAR the DTC's, road test and rerun on-board diagnostics or self-test.

Pinpoint Tests

The pinpoint tests are a step-by-step diagnostic process designed to determine the cause of a condition. It may not always be necessary to follow a pinpoint test to its conclusion. Carry out only the steps necessary to correct the condition. Then, test the system for normal operation. Sometimes, it is necessary to remove various vehicle components to gain access to the component requiring testing. Reinstall all components after verifying system operation is normal.

PINPOINT TEST A: BRAKE VIBRATION/SHUDDER

Test Step		Result / Action to Take
A1	ROAD TEST THE VEHICLE—LIGHT BRAKING	
	<ul style="list-style-type: none"> Check that the wheel and tires are correct for the vehicle. Inspect the tires for abnormal wear patterns. Road test the vehicle. Warm the brakes by slowing the vehicle a few times from 80-32 km/h (50-20 mph) using light braking applications. At highway speeds of 89-97 km/h (55-60 mph), apply the brake using a light pedal force. Is there a vibration/shudder felt in the steering wheel, seat or brake pedal? 	<p>Yes GO to A4.</p> <p>No GO to A2.</p>
A2	ROAD TEST THE VEHICLE—MODERATE TO HEAVY BRAKING	
	<ul style="list-style-type: none"> Road test the vehicle. At highway speeds of 89-97 km/h (55-60 mph), apply the brake using a moderate to heavy pedal force. Is there a vibration/shudder? 	<p>Yes For vehicles with ABS, GO to A3. For vehicles with standard brakes, GO to A4.</p> <p>No Vehicle is OK. VERIFY condition with customer. TEST the vehicle for normal operation.</p>
A3	NORMAL ACTUATION OF THE ABS SYSTEM	
	<ul style="list-style-type: none"> During moderate to heavy braking, noise from the hydraulic control unit (HCU) and pulsation in the brake pedal can be observed. Pedal pulsation coupled with noise during heavy braking or on loose gravel, bumps, wet or snowy surfaces is acceptable and indicates correct functioning of the ABS system. Pedal pulsation or steering wheel nibble (frequency is proportional to the vehicle speed) indicates a concern with a component. Is the vehicle speed sensitive? 	<p>Yes GO to A5.</p> <p>No The brake system is operating correctly.</p>

(Continued)



100% SATISFACTION GUARANTEED

BUY IT NOW!

Click Here To Order

PayPal American Express Discover MasterCard VISA

DIAGNOSIS AND TESTING (Continued)**PINPOINT TEST A: BRAKE VIBRATION/SHUDDER (Continued)**

Test Step		Result / Action to Take
A4	APPLICATION OF THE PARKING BRAKE	
	<ul style="list-style-type: none"> NOTE: Begin at the front of the vehicle unless the vibration or shudder has been isolated to the rear. This test is not applicable to vehicles with drum-in-hat type parking brakes. For vehicles with drum-in-hat parking brakes, proceed to the next test. For all other vehicles, apply the parking brake to identify if the problem is in the front or rear brake. At highway speeds of 89-97 km/h (55-60 mph), lightly apply the parking brake until the vehicle slows down. Release the parking brake immediately after the test. Is there a vibration/shudder? 	<p>Yes GO to A8.</p> <p>No GO to A5.</p>
A5	CHECK THE FRONT WHEEL BEARINGS	
	<ul style="list-style-type: none"> Check the front wheel bearings. Refer to Wheel Bearing Check in this section. Are the wheel bearings OK? 	<p>Yes GO to A6.</p> <p>No INSPECT the wheel bearings. ADJUST or REPAIR as necessary. TEST the system for normal operation.</p>
A6	CHECK THE FRONT SUSPENSION	
	<ul style="list-style-type: none"> Check the front suspension for: <ul style="list-style-type: none"> Broken or loose bolts. Damaged springs. Worn or damaged upper and lower control arm bushings. Loose or rough front bearings. Uneven tire wear. Are all the suspension components in satisfactory condition? 	<p>Yes GO to A7.</p> <p>No REPAIR or INSTALL new components as necessary. TEST the system for normal operation.</p>
A7	RESURFACE THE FRONT BRAKE DISCS	
	<ul style="list-style-type: none">  CAUTION: Do not use a bench lathe to machine brake discs. NOTE: Follow the manufacturer's instructions to machine the brake discs. After machining, make sure the brake disc meets the thickness specification. Resurface the front brake discs. Refer to Brake Disc Machining in this section. Road test the vehicle. Is the vibration/shudder present? 	<p>Yes GO to A8.</p> <p>No Vehicle is OK.</p>
A8	CHECK THE REAR SUSPENSION	
	<ul style="list-style-type: none"> Check the rear suspension for: <ul style="list-style-type: none"> Broken or loose bolts. Damaged or worn springs or spring bushings. Worn or damaged upper and lower control arm bushings. Worn or damaged trailing arms. Loose or rough rear bearings. Uneven tire wear. Are all the suspension components in satisfactory condition? 	<p>Yes GO to A9.</p> <p>No REPAIR or INSTALL new components as necessary. TEST the system for normal operation.</p>
A9	RESURFACE THE REAR BRAKE DISC OR DRUM	
	<ul style="list-style-type: none">  CAUTION: Do not use a bench lathe to machine brake discs. NOTE: Follow the manufacturers instructions to machine the brake discs. After machining, make sure the brake disc meets the thickness specification. Resurface the rear brake discs or drums. Refer to Brake Disc Machining in this section. Road test the vehicle. Is the vibration/shudder present? 	<p>Yes CHECK the front suspension for wear or damage, RESURFACE the front brake discs. TEST the system for normal operation.</p> <p>No Vehicle is OK.</p>



BUY IT NOW!

Click Here To Order 



DIAGNOSIS AND TESTING (Continued)

PINPOINT TEST B: ENGINE TICKING NOISE

Test Step		Result / Action to Take
B1	CHECK FOR TICKING NOISE AT THE FUEL RAIL	
	<ul style="list-style-type: none"> Disconnect the first fuel line clip. Is the ticking noise gone? 	<p>Yes CHECK for TSB for applicable vehicle. REPAIR as necessary. TEST the system for normal operation.</p> <p>No GO to B2.</p>
B2	CHECK FOR TICKING NOISE AT THE FUEL INJECTOR	
	<ul style="list-style-type: none"> Using an EngineEAR, listen at the fuel injectors by placing a probe on each injector. To isolate the faulty injector, disconnect the injector electrical connector and listen for the noise. Is the fuel injector the source of the ticking noise? 	<p>Yes INSTALL a new fuel injector. REFER to Section 303-04A for 4.6L engines or Section 303-04B for 5.4L engines. TEST the system for normal operation.</p> <p>No GO to B3.</p>
B3	CHECK THE BELT TENSIONER FOR TICKING NOISE	
	<ul style="list-style-type: none"> Inspect the accessory drive. Check for the belt tensioner bottoming at end of travel or not at end of stroke. Using an EngineEAR, listen at the belt tensioner. Is the belt tensioner the source of the noise? 	<p>Yes INSTALL a new belt tensioner. TEST the system for normal operation.</p> <p>No GO to B4.</p>
B4	CHECK THE WATER PUMP FOR TICKING NOISE	
	<ul style="list-style-type: none"> Using an EngineEAR, listen at the water pump for ticking noise. Is the water pump the source of the noise? 	<p>Yes INSTALL a new water pump. REFER to Section 303-03. TEST the system for normal operation.</p> <p>No GO to B5.</p>
B5	CHECK FOR AN OBSTRUCTION OF THE COOLING FAN	
	<ul style="list-style-type: none"> Inspect the cooling fan for obstructions. Check the cooling fan and shroud for wear or damage. Was there an obstruction or does the cooling fan show signs of damage? 	<p>Yes REPAIR or INSTALL a new cooling fan. REFER to Section 303-03. TEST the system for normal operation.</p> <p>No GO to B6.</p>
B6	CHECK THE OIL PUMP FOR TICKING NOISE	
	<ul style="list-style-type: none"> Check the oil pump using EngineEARs and probe at the oil filter adapter to verify the oil pump as a source. Is the oil pump the source of the noise? 	<p>Yes INSTALL a new oil pump. TEST the system for normal operation.</p> <p>No GO to B7.</p>
B7	CHECK VALVE LIFTERS OR LASH ADJUSTERS FOR CORRECT OPERATION	
	<ul style="list-style-type: none"> Check valve lifter/lash adjuster for correct operation, using EngineEARs. Are the valve lifters/lash adjusters operating correctly? 	<p>Yes VERIFY customer concern. CONDUCT a diagnosis of other suspect components.</p> <p>No INSTALL a new valve lifter/lash adjuster(s). TEST the system for normal operation.</p>



BUY IT NOW!

Click Here To Order



DIAGNOSIS AND TESTING (Continued)**PINPOINT TEST C: ACCESSORY DRIVE BEARING HOOT**

Test Step		Result / Action to Take
C1	CHECK THE ACCESSORY DRIVE IDLER AND TENSIONER PULLEY BEARINGS	<p>Yes INSTALL a new pulley/idler. CARRY OUT the Vehicle Cold Soak Procedure and TEST the system for normal operation.</p> <p>No CONDUCT a diagnosis on other suspect accessory drive components.</p>
	<ul style="list-style-type: none"> Carry out the Vehicle Cold Soak Procedure in this section. Key in START position. Place an EngineEAR probe directly on the pulley center post or bolt to verify which bearing is making the noise. Key in OFF position. Is either bearing making the noise? 	

PINPOINT TEST D: POWER STEERING MOAN

Test Step		Result / Action to Take
D1	CHECK THE POWER STEERING SYSTEM	<p>Yes GO to D2.</p> <p>No CONDUCT a diagnosis on other suspect accessory drive components.</p>
	<ul style="list-style-type: none"> Carry out the Vehicle Cold Soak Procedure in this section. Key in START position. Turn the steering wheel while the noise is occurring and listen for changes in sound pitch or loudness. Key in OFF position. Does the sound pitch or loudness change while turning the steering wheel? 	
D2	VERIFY THE SOURCE	<p>Yes VERIFY that the supply tube to the pump is unobstructed. CHECK the fluid condition and level. DRAIN the fluid and REFILL. CARRY OUT the Vehicle Cold Soak Procedure and TEST the system for normal operation.</p> <p>No Normal system operation.</p>
	<ul style="list-style-type: none"> Key in START position. Place an EngineEAR probe near the power steering pump/reservoir while the noise is occurring. While an assistant turns the steering wheel, listen for changes in sound pitch or loudness. Key in OFF position. Does the sound pitch or loudness change while turning the steering wheel? 	

PINPOINT TEST E: ENGINE DRIVEN COOLING FAN MOAN

Test Step		Result / Action to Take
E1	CHECK THE ENGINE DRIVEN COOLING FAN AFTER A COLD SOAK	<p>Yes TEST the fan for normal operation. If the fan tests normal, GO to E2. Otherwise, REPAIR as necessary.</p> <p>No Normal system operation.</p>
	<ul style="list-style-type: none"> Carry out the Vehicle Cold Soak Procedure in this section. Key in START position. Assess the airflow. Raise the engine speed to 1500 rpm while listening for the moan to increase in proportion to the airflow. Key in OFF position. Does the moan increase in proportion to the airflow? 	
E2	CHECK THE ENGINE DRIVEN COOLING FAN AT NORMAL OPERATING TEMPERATURE	<p>Yes Normal clutch operation.</p> <p>No INSTALL a new fan clutch. REFER to Section 303-03. TEST the system for normal operation.</p>
	<ul style="list-style-type: none"> Key in START position. Run the engine to normal operating temperature while listening for the moan to stop. Key in OFF position. Does the moan stop? 	

PINPOINT TEST F: DRUMMING NOISE

Test Step		Result / Action to Take
F1	CHECK THE EXHAUST SYSTEM	
	<ul style="list-style-type: none"> Key in START position. Increase the engine rpm until the noise is the loudest. Note the engine rpm. 	

(Continued)

100% SATISFACTION GUARANTEED

BUY IT NOW!

Click Here To Order

PayPal American Express Discover MasterCard VISA

DIAGNOSIS AND TESTING (Continued)

PINPOINT TEST F: DRUMMING NOISE (Continued)

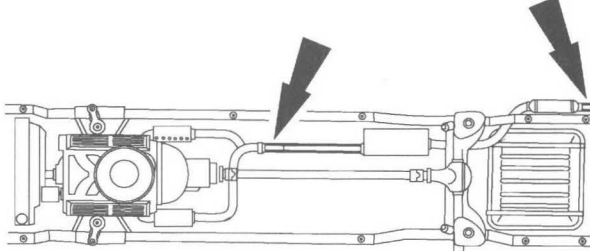
Test Step		Result / Action to Take
F1	<p>CHECK THE EXHAUST SYSTEM (Continued)</p> <ul style="list-style-type: none"> Add approximately 9 kg (20 lb) of weight to the exhaust system. First place the weight at the tail pipe and test, then at the front pipe.  <p>DF1768-A</p> <ul style="list-style-type: none"> Key in START position. Increase the engine rpm and listen for the drumming noise. Note the engine rpm if the noise occurs. Key in OFF position. Using a vibration analyzer (VA), determine the amount of vibration that occurs with the drumming noise. Is the noise/vibration reduced or eliminated, or does the noise/vibration occur at a different rpm? 	<p>Yes CARRY OUT Exhaust System Neutralizing in this section. TEST the system for normal operation.</p> <p>No GO to F2.</p>
F2	<p>POWERTRAIN/DRIVETRAIN MOUNT NEUTRALIZING</p> <ul style="list-style-type: none"> Carry out Powertrain/Drivetrain Mount Neutralizing in this section. Test the system for normal operation. Is the noise reduced or eliminated? 	<p>Yes Vehicle OK. TEST the system for normal operation.</p> <p>No CONDUCT diagnosis of other suspect components.</p>

PINPOINT TEST G: ENGINE TICKING, KNOCKING OR CONTINUOUS RATTLE

Test Step		Result / Action to Take
G1	<p>CHECK FOR NOISE AT THE VALVE COVERS AND THE FRONT COVERS (OHC ENGINES)</p> <ul style="list-style-type: none"> Carry out the Vehicle Cold Soak Procedure in this section. Key in START position. NOTE: For a short-duration ticking noise, multiple engine starts may be necessary. <p>Using an EngineEAR, listen closely at the valve covers and the front covers (OHC engines) by placing the probe near the surface of the valve cover and then on the surface front cover.</p> <ul style="list-style-type: none"> Key in OFF position. Is the noise source apparent? 	<p>Yes REMOVE the appropriate cover and INSPECT for loose, worn/broken components. REPAIR as necessary. TEST the system for normal operation.</p> <p>No GO to G2.</p>
G2	<p>CHECK FOR NOISE AT THE CYLINDER BLOCK</p> <ul style="list-style-type: none"> Key in START position. Using an EngineEAR, listen closely at the cylinder block by placing a probe on or near each freeze plug. Key in OFF position. Is the noise source apparent? 	<p>Yes REPAIR or INSTALL new components as necessary.</p> <p>No GO to G3.</p>
G3	<p>CHECK FOR NOISE WHILE DISCONNECTING EACH FUEL INJECTOR ELECTRICAL CONNECTOR, ONE AT A TIME</p> <ul style="list-style-type: none"> Key in START position. Disconnect the electrical connector, one at a time, and listen for the noise. Is the noise reduced or eliminated? 	<p>Yes INSTALL a new fuel injector. TEST the system for normal operation.</p> <p>No INSPECT accessory drive or the transmission as a possible source.</p>



100% SATISFACTION GUARANTEED

BUY IT NOW!

Click Here To Order

PayPal, American Express, Discover, MasterCard, VISA

DIAGNOSIS AND TESTING (Continued)

PINPOINT TEST H: FRONT SUSPENSION NOISE

Test Step		Result / Action to Take
H1	ROAD TEST THE VEHICLE	
	<ul style="list-style-type: none"> Test drive the vehicle. NOTE: An assistant will be needed for this road test. During the road test, drive the vehicle over a rough road. Using ChassisEARS, determine from which area/component the noise is originating. Is there a squeak, creak or rattle noise? 	<p>Yes GO to H2.</p> <p>No The suspension system is OK. CONDUCT a diagnosis on other suspect systems.</p>
H2	INSPECT THE STEERING SYSTEM	
	<ul style="list-style-type: none">  WARNING: The electrical power to the air suspension system must be shut off prior to hoisting, jacking or towing an air suspension vehicle. This can be accomplished by turning off the air suspension switch. Failure to do so can result in unexpected inflation or deflation of the air springs, which can result in shifting of the vehicle during these operations. Raise and support the vehicle. Check the steering system for wear or damage. Carry out a steering linkage test. Refer Section 211-00. Inspect the tire wear pattern. Refer to Tire Wear Patterns chart in this section. Are the steering components worn or damaged? 	<p>Yes REPAIR the steering system. INSTALL new components as necessary. TEST the system for normal operation.</p> <p>No GO to H3.</p>
H3	FRONT SHOCK ABSORBER/STRUT CHECK	
	<ul style="list-style-type: none"> Check the front shock absorbers/strut mounts for loose bolts or nuts. Check the front shock absorbers/struts for wear or damage. Carry out a "bounce test". Are the front shock absorbers/struts loose or damaged? 	<p>Yes TIGHTEN to specifications if loose. INSTALL new front shock absorbers/struts if damaged. TEST the system for normal operation.</p> <p>No GO to H4.</p>
H4	CHECK THE FRONT SPRINGS	
	<ul style="list-style-type: none"> Check the front spring and front spring mounts/brackets for wear or damage. Are the front springs or spring mounts/brackets worn or damaged? 	<p>Yes REPAIR or INSTALL new components as necessary. TEST the system for normal operation.</p> <p>No GO to H5.</p>
H5	CHECK THE CONTROL ARMS/RADIUS ARMS	
	<ul style="list-style-type: none"> Inspect the control arm bushings for wear or damage. Inspect for twisted or bent control arm/radius arm. Are the control arm/radius arms damaged or worn? 	<p>Yes REPAIR or INSTALL new components as necessary. TEST the system for normal operation.</p> <p>No GO to H6.</p>
H6	CHECK THE STABILIZER BAR/TRACK BAR	
	<ul style="list-style-type: none"> Check the stabilizer bar/track bar bushings and links for damage or wear. Check the stabilizer bar/track bar for damage. Check for loose or damaged stabilizer bar isolators or brackets. Are the stabilizer bar/track bar components loose, worn or damaged? 	<p>Yes REPAIR or INSTALL new components as necessary. TEST the system for normal operation.</p> <p>No Suspension system OK. CONDUCT diagnosis on other suspect systems.</p>

PINPOINT TEST I: REAR SUSPENSION NOISE

Test Step		Result / Action to Take
I1	ROAD TEST THE VEHICLE	
	<ul style="list-style-type: none"> Test drive the vehicle. NOTE: An assistant will be needed for this road test. Drive the vehicle over a rough road. Using ChassisEARS, determine from which area/component the noise is originating. Is there a squeak, creak or rattle noise? 	<p>Yes GO to I2.</p> <p>No The suspension system is OK. Conduct a diagnosis on other suspect systems.</p>

(Continued)



BUY IT NOW!

Click Here To Order



DIAGNOSIS AND TESTING (Continued)

PINPOINT TEST I: REAR SUSPENSION NOISE (Continued)

Test Step		Result / Action to Take
I2	REAR SHOCK ABSORBER/STRUT CHECK	<p>Yes TIGHTEN to specifications if loose. INSTALL new rear shock absorbers/struts if damaged. TEST the system for normal operation.</p> <p>No GO to I3.</p> <p>Yes REPAIR or INSTALL new components as necessary. TEST the system for normal operation.</p> <p>No GO to I4.</p> <p>Yes REPAIR or INSTALL new components as necessary. TEST the system for normal operation.</p> <p>No GO to I5.</p> <p>Yes REPAIR or INSTALL new components as necessary. Test the system for normal operation.</p> <p>No Suspension system OK. CONDUCT diagnosis on other suspect systems.</p>
<ul style="list-style-type: none"> ⚠ WARNING: The electrical power to the air suspension system must be shut off prior to hoisting, jacking or towing an air suspension vehicle. This can be accomplished by turning off the air suspension switch. Failure to do so can result in unexpected inflation or deflation of the air springs, which can result in shifting of the vehicle during these operations. Raise and support the vehicle. Check the rear shock absorber/strut mounts for loose bolts or nuts. Check the rear shock absorbers/struts for damage. Carry out a shock absorber check. Are the rear shock absorbers/struts loose or damaged? 		
I3	CHECK THE REAR SPRINGS	
<ul style="list-style-type: none"> Check the rear springs and rear spring mounts/brackets for wear or damage. Are the rear springs or spring mounts/brackets worn or damaged? 		
I4	CHECK THE CONTROL ARMS/TRAILING ARMS	
<ul style="list-style-type: none"> Inspect the control arm/trailing arm bushings for wear or damage. Check for loose control arm/trailing arm bolts. Inspect for twisted or bent control arm/trailing arms. Are the control arm/trailing arms loose, damaged or worn? 		
I5	CHECK THE STABILIZER BAR/TRACK BAR	
<ul style="list-style-type: none"> Check the stabilizer bar/track bar bushings and links for damage or wear. Check the stabilizer bar/track bar for damage. Check for loose or damaged stabilizer bar isolators or brackets. Are the stabilizer bar/track bar components loose, worn or damaged? 		

PINPOINT TEST J: WHEEL AND TIRE

Test Step		Result / Action to Take
J1	ROAD TEST THE VEHICLE	<p>Yes GO to J2.</p> <p>No The wheel and tires are OK. CONDUCT a diagnosis on other suspect systems.</p> <p>Yes GO to J3.</p> <p>No INSPECT the wheel bearings. ADJUST or REPAIR as necessary. TEST the system for normal operation.</p>
<ul style="list-style-type: none"> NOTE: Wheel or tire vibrations felt in the steering wheel are most likely related to the front wheel or tire. Vibration felt through the seat are most likely related to the rear wheel or tire. This may not always be true, but it can help to isolate the problem to the front or rear of the vehicle. Test drive the vehicle at different speed ranges. During the road test, if the vibration can be eliminated by placing the vehicle in neutral or is affected by the speed of the engine, the cause is not the wheels or tires. Is there a vibration and noise? 		
J2	CHECK THE FRONT WHEEL BEARINGS	
<ul style="list-style-type: none"> Check the front wheel bearings. Refer to Wheel Bearing Check in this section. Are the wheel bearings OK? 		

(Continued)

100% SATISFACTION GUARANTEED

BUY IT NOW!

Click Here To Order

PayPal American Express Discover MasterCard VISA

DIAGNOSIS AND TESTING (Continued)

PINPOINT TEST J: WHEEL AND TIRE (Continued)

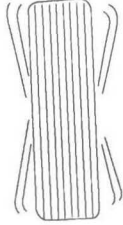
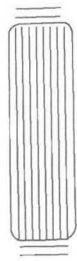
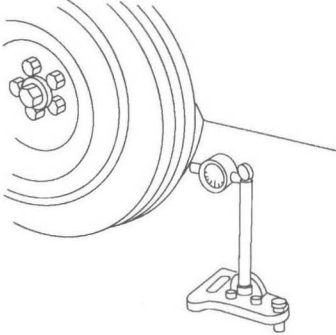
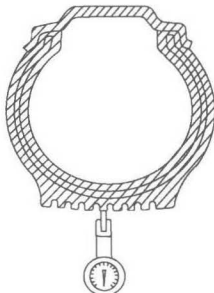
Test Step		Result / Action to Take
J3	<p>INSPECT THE TIRES</p> <ul style="list-style-type: none"> • Check the tires for missing weights. • Check the wheels for damage. • Inspect the tire wear pattern. Refer to the Tire Wear Patterns chart in this section. • Do the tires have an abnormal wear pattern? 	<p>Yes CORRECT the condition that caused the abnormal wear. INSTALL new tire(s). TEST the system for normal operation.</p> <p>No GO to J4.</p>
J4	<p>TIRE ROTATION DIAGNOSIS</p> <ul style="list-style-type: none"> • Spin the tires slowly and watch for signs of lateral runout. <div style="text-align: center;">  </div> <p>DF1713-A</p> <ul style="list-style-type: none"> • Spin the tires slowly and watch for signs of radial runout. <div style="text-align: center;">  </div> <p>DF1714-A</p> <ul style="list-style-type: none"> • Are there signs of visual runout? 	<p>Yes GO to J5.</p> <p>No CHECK the wheel and tire balance. CORRECT as necessary. TEST the system for normal operation.</p>
J5	<p>RADIAL RUNOUT CHECK ON THE TIRE</p> <ul style="list-style-type: none"> • Measure the radial runout of the wheel and tire assembly. A typical specification for total radial runout is 1.14 mm (0.045 in). <div style="display: flex; justify-content: space-around;">   </div> <p>specifications?</p>	<p>Yes GO to J8.</p> <p>No GO to J6.</p>

100% SATISFACTION GUARANTEED

BUY IT NOW!

Click Here To Order



(Continued)

DIAGNOSIS AND TESTING (Continued)

PINPOINT TEST J: WHEEL AND TIRE (Continued)

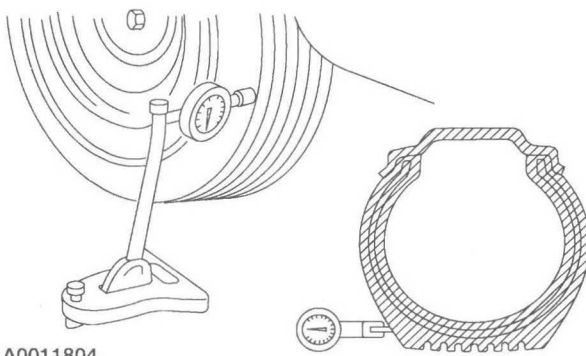
Test Step		Result / Action to Take
J6	RADIAL RUNOUT CHECK ON THE WHEEL	<p>Yes INSTALL a new tire. TEST the system for normal operation.</p> <p>No GO to J7.</p>
	<ul style="list-style-type: none"> • Measure the radial runout of the wheel. A typical specification for total radial runout is 1.14 mm (0.045 in). • Is the radial runout within specifications? 	
J7	CHECK THE HUB/BRAKE DISC OR DRUM PILOT RUNOUT OR BOLT CIRCLE RUNOUT	<p>Yes INSTALL a new wheel. TEST the system for normal operation.</p> <p>No REPAIR or INSTALL new components as necessary. REFER to Section 204-00.</p>
	<ul style="list-style-type: none"> • Measure the pilot or bolt circle runout. A typical specification for radial runout is: <ul style="list-style-type: none"> • Pilot runout— less than 0.15 mm (0.006 inch). • Bolt circle runout— less than 0.38 mm (0.015 inch). • Is the radial runout within specifications? 	
J8	LATERAL RUNOUT CHECK ON THE TIRE	<p>Yes Wheel and tires OK. CONDUCT diagnosis on other suspect systems.</p> <p>No GO to J9.</p>
	<ul style="list-style-type: none"> • Measure the lateral runout of the wheel and tire assembly. A typical specification for total lateral runout is 1.14 mm (0.045 inch).  <p>A0011804</p> <ul style="list-style-type: none"> • Is the lateral runout within specifications? 	
J9	LATERAL RUNOUT CHECK ON THE WHEEL	<p>Yes INSTALL a new tire. TEST the system for normal operation.</p> <p>No GO to J10.</p>
	<ul style="list-style-type: none"> • Measure the lateral runout of the wheel. A typical specification for total radial runout is 1.14mm (0.045 inch). • Is the lateral runout within specifications? 	
J10	CHECK THE FLANGE FACE LATERAL RUNOUT	<p>Yes INSTALL a new wheel. TEST the system for normal operation.</p> <p>No REPAIR or INSTALL new components as necessary. REFER to Section 204-00.</p>
	<ul style="list-style-type: none"> • Measure the flange face lateral runout. A typical specification for lateral runout is: <ul style="list-style-type: none"> • Hub/brake disc— less than 0.13 mm (0.005 inch). • Axle shaft— less than 0.25 mm (0.010 inch). • Is the lateral runout within specifications? 	

PINPOINT TEST K: HIGH SPEED SHAKE OR SHIMMY DIAGNOSIS

Test Step		Result / Action to Take
K1	CHECK FOR FRONT WHEEL BEARING ROUGHNESS	<p>Yes INSPECT the wheel bearings. REPAIR as necessary. TEST the system for normal operation.</p> <p>No GO to K2.</p>
	<ul style="list-style-type: none"> • Chock the rear wheels. • Raise and support the front end of the vehicle so that the front wheel and tire assemblies can spin. • Spin the front tires by hand. Refer to Wheel Bearing Check in this section. • Do the wheel bearings feel rough? 	

(Continued)



100% SATISFACTION GUARANTEED

BUY IT NOW!

Click Here To Order

PayPal American Express Discover MasterCard VISA

DIAGNOSIS AND TESTING (Continued)

PINPOINT TEST K: HIGH SPEED SHAKE OR SHIMMY DIAGNOSIS (Continued)

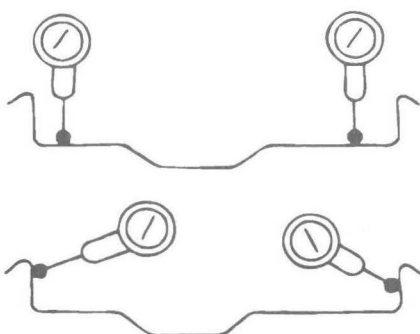
Test Step		Result / Action to Take
K2	CHECK THE END PLAY OF THE FRONT WHEEL BEARINGS	<p>Yes GO to K3.</p> <p>No ADJUST or REPAIR as necessary. TEST the system for normal operation.</p>
	<ul style="list-style-type: none"> Check the end play of the front wheel bearings. Refer to REFER to Section 204-00. Is the end play OK? 	
K3	MEASURE THE LATERAL RUNOUT AND THE RADIAL RUNOUT OF THE FRONT WHEELS ON THE VEHICLE	<p>Yes GO to K4.</p> <p>No INSTALL new wheels as necessary and BALANCE the assembly. TEST the system for normal operation.</p>
	<ul style="list-style-type: none"> Measure the lateral runout and the radial runout of the front wheels on the vehicle. GO to Pinpoint Test J. Are the measurements within specifications? 	
K4	MEASURE THE LATERAL RUNOUT OF THE FRONT TIRES ON THE VEHICLE	<p>Yes GO to K5.</p> <p>No INSTALL new tires as necessary and BALANCE the assembly. TEST the system for normal operation.</p>
	<ul style="list-style-type: none"> Measure the lateral runout of the front tires on the vehicle. GO to Pinpoint Test J. Is the runout within specifications? 	
K5	MEASURE THE RADIAL RUNOUT OF THE FRONT TIRES ON THE VEHICLE	<p>Yes BALANCE the front wheel and tire assemblies. If any tire cannot be balanced, INSTALL a new tire. TEST the system for normal operation.</p> <p>No GO to K6.</p>
	<ul style="list-style-type: none"> Measure the radial runout of the front tires on the vehicle. GO to Pinpoint Test J. Is the runout within specifications? 	
K6	MATCH MOUNT THE TIRE AND WHEEL ASSEMBLY	<p>Yes BALANCE the assembly. TEST the system for normal operation.</p> <p>No If the high spot is not within 101.6 mm (4 inches) of the first high spot on the tire, GO to K7.</p>
	<ul style="list-style-type: none"> Mark the high runout location on the tire and also on the wheel. Break the assembly down and rotate the tire 180 degrees (halfway around) on the wheel. Inflate the tire and measure the radial runout. Is the runout within specifications? 	
K7	MEASURE THE WHEEL FLANGE RUNOUT	<p>Yes LOCATE and MARK the low spot on the wheel. INSTALL the tire, matching the high spot on the tire with the low spot on the wheel. BALANCE the assembly. TEST the system for normal operation. If the condition persists, GO to K8.</p> <p>No INSTALL a new wheel. CHECK the runout on the new wheel. If the new wheel is within limits, LOCATE and MARK the low spot. INSTALL the tire, matching the high spot on the tire with the low spot on the wheel. BALANCE the assembly. TEST the system for normal operation. If the condition persists, GO to K8.</p>
	<ul style="list-style-type: none"> Dismount the tire and mount the wheel on a wheel balancer. Measure the runout on both wheel flanges. Refer to Section 204-00.  <p style="text-align: right;">DG0199-A</p>	

(Continued)



BUY IT NOW!

Click Here To Order



DIAGNOSIS AND TESTING (Continued)

PINPOINT TEST K: HIGH SPEED SHAKE OR SHIMMY DIAGNOSIS (Continued)

Test Step		Result / Action to Take
K8	CHECK FOR VIBRATION FROM THE FRONT OF THE VEHICLE	
	<p>⚠ WARNING: If only one drive wheel is allowed to rotate, speed must be limited to 55 km/h (34 mph) using the speedometer reading, since actual wheel speed will be twice that indicated on the speedometer. Exceeding a speed of 55 km/h (34 mph) or allowing the drive wheel to hang unsupported can result in tire disintegration or differential failure, which can cause serious personal injury and extensive vehicle damage.</p> <ul style="list-style-type: none"> Spin the front wheel and tire assemblies with a wheel balancer while the vehicle is raised on a hoist. Feel for vibration in the front fender or while seated in the vehicle. Is the vibration present? 	<p>Yes SUBSTITUTE known good wheel and tire assemblies as necessary. TEST the system for normal operation.</p> <p>No GO to K9.</p>
K9	CHECK FOR VIBRATION FROM THE REAR OF THE VEHICLE	
	<p>⚠ WARNING: If only one drive wheel is allowed to rotate, speed must be limited to 55 km/h (34 mph) using the speedometer reading, since actual wheel speed will be twice that indicated on the speedometer. Exceeding a speed of 55 km/h (34 mph) or allowing the drive wheel to hang unsupported can result in tire disintegration or differential failure, which can cause serious personal injury and extensive vehicle damage.</p> <ul style="list-style-type: none"> Chock the front wheels. Raise and support the rear end of the vehicle so that the rear wheel and tire assemblies can spin. Engage the drivetrain and carefully accelerate the drive wheels while checking for vibration. Is the vibration present? 	<p>Yes GO to K10.</p> <p>No TEST the system for normal operation.</p>
K10	CHECK THE DRIVETRAIN	
	<p>⚠ WARNING: If only one drive wheel is allowed to rotate, speed must be limited to 55 km/h (34 mph) using the speedometer reading, since actual wheel speed will be twice that indicated on the speedometer. Exceeding a speed of 55 km/h (34 mph) or allowing the drive wheel to hang unsupported can result in tire disintegration or differential failure, which can cause serious personal injury and extensive vehicle damage.</p> <ul style="list-style-type: none"> Remove the rear wheel and tire assemblies. Secure the brake drums (if so equipped), by installing wheel hub bolt nuts, reversed. Carefully accelerate the drivetrain while checking for vibration. Is the vibration present? 	<p>Yes CHECK/TEST the drivetrain and driveline components. TEST the system for normal operation.</p> <p>No SUBSTITUTE known good wheel and tire assemblies as necessary. TEST the system for normal operation.</p>

PINPOINT TEST L: CLUTCH VIBRATION

Test Step		Result / Action to Take
L1	CHECK ENGINE COMPONENTS FOR GROUNDING	
	<ul style="list-style-type: none"> NOTE: Make sure the clutch is the cause of the vibration concern. The vibration should occur during clutch operation. The clutch can also be difficult to engage or disengage. Eliminate all related systems before checking the clutch components. NOTE: Check the driveline angles and driveshaft runout before disassembling the clutch system. Refer to Section 205-00. Check the powertrain/drivetrain mounts, exhaust manifolds or other engine components for grounding on the chassis. Are any mounts or engine components grounded? 	<p>Yes REPAIR as necessary. TEST the system for normal operation.</p> <p>No GO to L2.</p>
L2	CHECK THE ACCESSORY DRIVE	
	<ul style="list-style-type: none"> Remove the accessory drive belt. Does the vibration stop with the accessory drive belt 	<p>Yes DIAGNOSE the accessory drive components.</p> <p>No GO to L3.</p>



BUY IT NOW!

Click Here To Order



(Continued)

DIAGNOSIS AND TESTING (Continued)

PINPOINT TEST L: CLUTCH VIBRATION (Continued)

Test Step		Result / Action to Take
L3	CHECK FOR LOOSE CLUTCH PRESSURE PLATE BOLTS	<p>Yes TIGHTEN the bolts to specifications or if damaged, INSTALL a new clutch pressure plate. REFER to Section 308-07. TEST the system for normal operation.</p> <p>No GO to L4.</p>
	<ul style="list-style-type: none"> Check for loose clutch pressure plate bolts. Inspect the clutch pressure plate for damage or for material between the pressure plate and flywheel. Are there any loose bolts or damage? 	
L4	CHECK THE CLUTCH DISC SPRINGS	<p>Yes INSTALL a new clutch disc. TEST the system for normal operation.</p> <p>No GO to L5.</p>
	<ul style="list-style-type: none"> Check for worn, broken or loose clutch disc springs. Are the clutch springs worn, broken or loose? 	
L5	CHECK THE CLUTCH DISC SPLINES	<p>Yes INSTALL a new clutch disc. TEST the system for normal operation.</p> <p>No GO to L6.</p>
	<ul style="list-style-type: none"> Inspect the clutch disc splines for damage or wear. Is there damage or wear? 	
L6	CHECK THE FLYWHEEL BOLTS	<p>Yes TIGHTEN the bolts to specifications. TEST the system for normal operation.</p> <p>No GO to L7.</p>
	<ul style="list-style-type: none"> Check for loose flywheel bolts. Are the bolts loose? 	
L7	CHECK THE FLYWHEEL SURFACE	<p>Yes INSTALL a new flywheel. TEST the system for normal operation.</p> <p>No Clutch system normal. CONDUCT a diagnosis on other suspect systems.</p>
	<ul style="list-style-type: none"> Inspect the flywheel surface for wear or damage. Check the flywheel runout. Is there any damage or excessive wear? 	

PINPOINT TEST M: TRANSFER CASE VIBRATION

Test Step		Result / Action to Take
M1	INSPECT THE TRANSFER CASE	<p>Yes TIGHTEN to specifications or INSTALL new bolts as necessary. TEST the system for normal operation.</p> <p>No GO to M2.</p>
	<ul style="list-style-type: none">  WARNING: The electrical power to the air suspension system must be shut off prior to hoisting, jacking or towing an air suspension vehicle. This can be accomplished by turning off the air suspension switch. Failure to do so can result in unexpected inflation or deflation of the air springs, which can result in shifting of the vehicle during these operations. Inspect the transfer case for loose or missing mounting bolts. Check for fluid seepage between the transfer case and the transmission. Are the mounting bolts missing or loose? 	
M2	INSPECT THE REAR DRIVESHAFT	<p>Yes REPAIR or INSTALL a new driveshaft as necessary. TEST the system for normal operation.</p> <p>No GO to M3.</p>
	<ul style="list-style-type: none"> NOTE: Verify that the driveshaft and pinion flange index marks are aligned. Inspect the driveshaft for missing weights, damage or undercoating. Inspect the U-joints for freedom of movement. Check driveshaft runout and, if necessary, check the pinion flange runout. Are the driveshaft or pinion flange worn or damaged or 	

(Continued)



BUY IT NOW!

Click Here To Order



DIAGNOSIS AND TESTING (Continued)**PINPOINT TEST M: TRANSFER CASE VIBRATION (Continued)**

Test Step		Result / Action to Take
M3	CHECK THE DRIVELINE ANGLES	
	<ul style="list-style-type: none"> Measure the rear driveshaft and pinion angles. Refer to Section 205-00. Measure the front driveshaft and pinion angles. Refer to Section 205-00. Are the driveline angles incorrect? 	<p>Yes REPAIR as necessary. TEST the system for normal operation.</p> <p>No GO to M4.</p>
M4	INSPECT THE FRONT DRIVESHAFT	
	<ul style="list-style-type: none"> NOTE: Verify that the driveshaft and pinion flange index marks are aligned. Inspect the front driveshaft for missing weights, damage or undercoating. Inspect the U-joints and slip yoke for freedom of movement. Check driveshaft runout and, if necessary, check the pinion flange runout. Is the driveshaft or U-joints worn or damaged? 	<p>Yes REPAIR or INSTALL a new driveshaft as necessary. TEST the system for normal operation.</p> <p>No GO to M5.</p>
M5	ROAD TEST WITH THE FRONT DRIVESHAFT ONLY	
	<ul style="list-style-type: none"> NOTE: Index mark the driveshaft to the pinion flange and to the output shaft before removal. Remove the rear driveshaft. Plug the transfer case with an output shaft seal plug. NOTE: Shift the transfer case into 4WD high so the vehicle is driven by the front driveshaft only. Test drive the vehicle. Is the vibration gone? 	<p>Yes INSTALL and BALANCE the rear driveshaft. TEST the system for normal operation.</p> <p>No GO to M6.</p>
M6	ROAD TEST WITH THE REAR DRIVESHAFT ONLY	
	<ul style="list-style-type: none"> NOTE: Index mark the front driveshaft to the pinion flange. Remove the front driveshaft. Test drive the vehicle. Is the vibration gone? 	<p>Yes INSTALL and BALANCE the front driveshaft. TEST the system for normal operation.</p> <p>No GO to M7.</p>
M7	TRANSFER CASE TAIL SHAFT INSPECTION	
	<ul style="list-style-type: none"> Inspect the splines of the output shaft for wear or damage. Inspect the splines of the driveshaft slip yoke for wear or damage. Are the splines worn or damaged? 	<p>Yes REPAIR or INSTALL new components as necessary. TEST the system for normal operation.</p> <p>No The transfer case is OK. CONDUCT a diagnosis on other suspect systems.</p>

Component Tests**Idle Air Control (IAC) Valve**

- Open the hood.
- NOTE:** Key symptom is elevated idle speed while noise is occurring.
NOTE: "Snapping" the throttle can induce the noise.
Verify the condition by operating the vehicle for a short time.
- Inspect the IAC valve. If physical evidence of contamination exists, install a new IAC valve.

- While the noise is occurring, either place an EngineEAR probe near the IAC valve and the inlet tube, or create a 6.35 mm (0.25 in)-12.7 mm (0.50 in) air gap between the inlet tube and the clean air tube. If the IAC valve is making the noise, install a new IAC valve.
- Test the vehicle for normal operation.

Steering Gear Grunt/Shudder Test

- Start and run the vehicle to operating temperature.
- Set engine idle speed to 1200 rpm.

100% SATISFACTION GUARANTEED

BUY IT NOW!

Click Here To Order

PayPal American Express Discover MasterCard VISA

DIAGNOSIS AND TESTING (Continued)

3.  **CAUTION: Do not hold the steering wheel against the stops for more than three to five seconds at a time. Damage to the power steering pump will occur.**

Rotate the steering wheel to the RH stop, then turn the steering wheel 90° back from that position. Turn the steering wheel slowly in a 15° to 30° arc.

4. Turn the steering wheel another 90°. Turn the steering wheel slowly in a 15° to 30° arc.
5. Repeat the test with power steering fluid at different temperatures.
6. If a light grunt is heard or a low (50-200 Hz) shudder is present, this is a normal steering system condition.
7. If a loud grunt is heard, or a strong shudder is felt, fill and purge the power steering system.

Checking Tooth Contact Pattern and Condition of the Ring and Pinion

There are two basic types of conditions that will produce ring and pinion noise. The first type is a howl or chuckle produced by broken, cracked, chipped, scored or forcibly damaged gear teeth and is usually quite audible over the entire speed range. The second type of ring and pinion noise pertains to the mesh pattern of the gear pattern. This gear noise can be recognized as it produces a cycling pitch or whine. Ring and pinion noise tends to peak in a narrow speed range or ranges, and will tend to remain constant in pitch.

1. Raise and support the vehicle. For additional information, refer to Section 100-00.
2. Drain the axle lubricant. Refer to Section 205-00 for rear axles or front axles.
3. Remove the carrier assembly or the axle housing cover depending on the axle type. Refer to Section 205-00 for rear axles or front axles.
4. Inspect the gear set for scoring or damage.

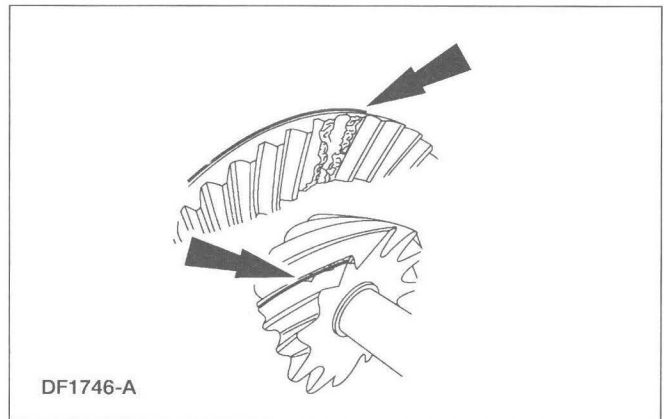
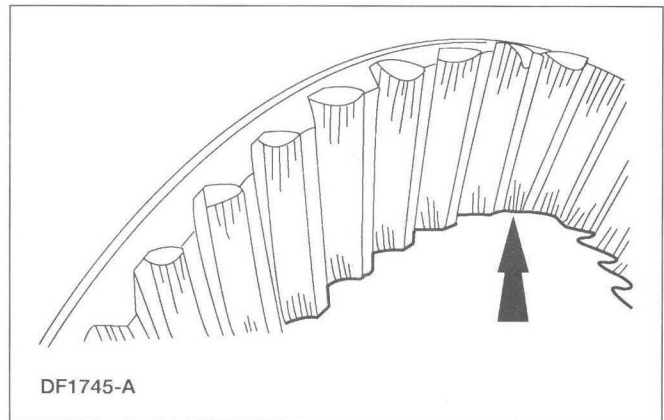

5. In the following steps, the movement of the contact pattern along the length is indicated as toward the "heel" or "toe" of the differential ring gear.

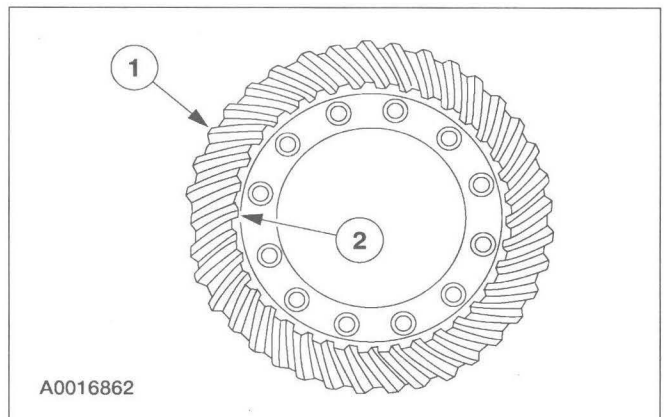

Item	Description
1	Heel
2	Toe



DIAGNOSIS AND TESTING (Continued)

6. Apply a marking compound to a third of the gear teeth on the differential ring gear. Rotate the differential ring gear several complete turns in both directions until a good, clear tooth pattern is obtained. Inspect the contact patterns on the ring gear teeth.
7. A good contact pattern should be centered on the tooth. It can also be slightly toward the toe. There should always be some clearance between the contact pattern and the top of the tooth.
- Tooth contact pattern shown on the drive side of the gear teeth.

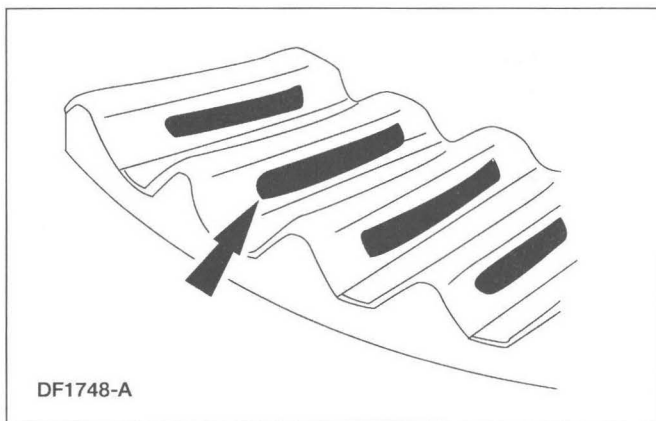

8. A high, thick contact pattern that is worn more toward the toe.
- Tooth contact pattern shown on the drive side of the gear teeth.
 - The high contact pattern indicates that the drive pinion is not installed deep enough into the carrier.
 - The differential ring gear backlash is correct, a thinner drive pinion shim is needed. A decrease will move the drive pinion toward the differential ring gear.



9. A high, thin contact pattern that is worn toward the toe.
- Tooth contact pattern shown on the drive side of the gear teeth.
 - The drive pinion depth is correct. Increase the differential ring gear backlash.

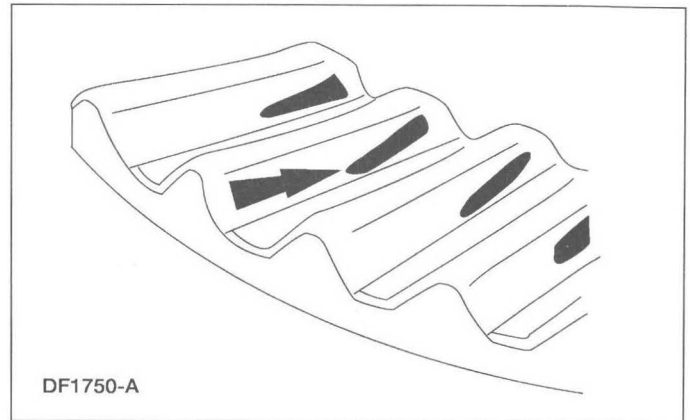

10. A contact pattern that is worn in the center of the differential ring gear tooth toward the heel.
- Tooth contact pattern shown on the drive side of the gear teeth.
 - The low contact pattern indicates that the drive pinion is installed too deep into the carrier.
 - The differential ring gear backlash is correct. A thicker drive pinion shim is needed.

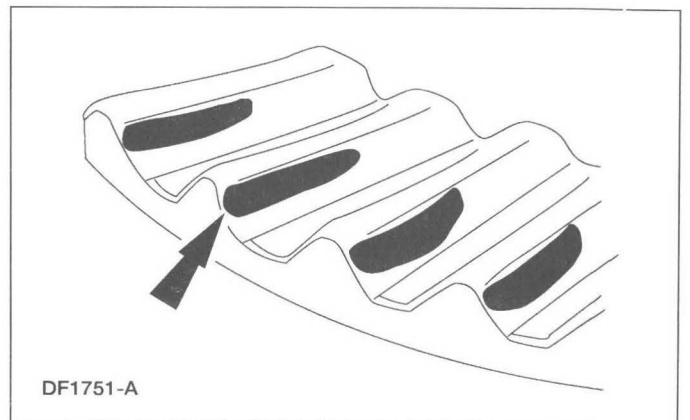

BUY IT NOW!

Click Here To Order



DIAGNOSIS AND TESTING (Continued)

11. A contact pattern that is worn at the top of the differential ring gear tooth toward the heel.
 - Tooth contact pattern shown on the drive side of the gear teeth.
 - The pinion gear depth is correct. Decrease the differential ring gear backlash.

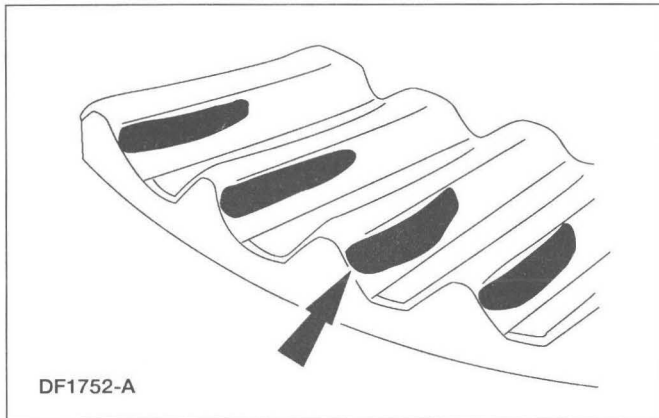
**Front Drive Axle Halfshaft Rotation Speed**

1. With the vehicle in NEUTRAL, position it on a hoist.
2. Remove the front differential cover and allow the fluid to drain.
3. Remove and discard the differential pinion shaft retaining bolt.
4. Remove the differential pinion shaft.
5. Remove and discard both axle shaft snap rings.
6. Push the axle shafts outboard beyond the face of the differential side gears.
7. Place a Traction-Lok® differential clutch spring between the differential side gears.
 - Use a soft-faced hammer to install the differential clutch spring.
8. Install new axle shaft snap rings.
9. Install the pinion shaft and a new pinion shaft lock bolt.
10. Install the differential housing cover. Refer to Section 205-00.
11. Fill the front axle with the specified fluid and amount.

100% SATISFACTION GUARANTEED

BUY IT NOW!

Click Here To Order









DIAGNOSIS AND TESTING (Continued)

Tire Wear Patterns and frequency calculations

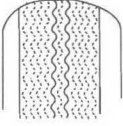
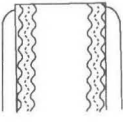
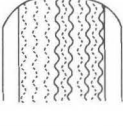
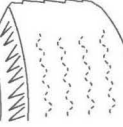
Tire Wear Chart

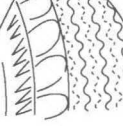
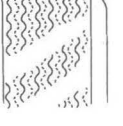
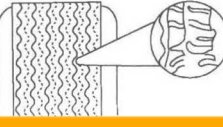
TIRE WEAR	CONDITION	POSSIBLE CAUSES
	<ul style="list-style-type: none"> • Rapid wear at both shoulders. 	<ul style="list-style-type: none"> • Tires underinflated. • Worn suspension components. • Excessive cornering speeds. • Lack of rotation.
	<ul style="list-style-type: none"> • Rapid wear at the center. 	<ul style="list-style-type: none"> • Tires overinflated. • Lack of rotation. • Excessive toe on drive wheels. • Heavy acceleration on drive wheels.
	<ul style="list-style-type: none"> • Wear at one shoulder. 	<ul style="list-style-type: none"> • Toe adjustment out of specification. • Camber out of specification. • Damaged strut. • Damaged lower control arm.
	<ul style="list-style-type: none"> • Feather edges. 	<ul style="list-style-type: none"> • Toe adjustment out of specification. • Damaged or worn tie rods. • Damaged spindle or knuckle.
	<ul style="list-style-type: none"> • Bald spots or cupping. 	<ul style="list-style-type: none"> • Unbalanced wheel. • Excessive radial runout. • Worn strut or shock absorber.
	<ul style="list-style-type: none"> • Tire scalloped. 	<ul style="list-style-type: none"> • Toe adjustment out of specification. • Camber out of specification. • Worn or damaged suspension components.
	<ul style="list-style-type: none"> • Wear pattern - FWD vehicles. 	<ul style="list-style-type: none"> • Excessive toe on non-drive wheels. • Lack of rotation.
	<ul style="list-style-type: none"> • Wear pattern - FWD vehicles. • Edge of thread blocks worn. 	<ul style="list-style-type: none"> • Excessive toe on non-drive wheels. • Lack of rotation.



BUY IT NOW!

Click Here To Order





**TECHNICAL
SUPPORT OPERATIONS**
Ford Customer Service Division

100% SATISFACTION GUARANTEED

BUY IT NOW!

Click Here To Order 

PayPal    

LITHO IN U.S.A.
AD-2640



FCS-13790-04