

2002 Workshop Manual



License #84356800

*** DEMO / SAMPLE ***

This DEMO contains only a few pages of the entire manual/product.

Not all Bookmarks work on the DEMO, but they do on the full version.

Features:

- Searchable text
- Printable pages
- Bookmarked for easy navigation
- High Resolution images
- Zoom to see exact details
- Money back Guarantee
- Available on USB and eBook download

[Buy Now](#)



** Watch Video **
explains how to
purchase and
access your eBook



BUY IT NOW!

[Click Here To Order](#)



F-150

VOLUME 1 AND 2

Motor Company

Copyright © 2025, Forel Publishing Company, LLC, Woodbridge, Virginia

All Rights Reserved. No part of this book may be used or reproduced in any manner whatsoever without written permission of Forel Publishing Company, LLC. For information write to Forel Publishing Company, LLC, Woodbridge, VA 22192

2002 Ford F-150 Truck Workshop Manual (Volume 1 and 2)

EAN: 978-1-60371-489-1

ISBN: 1-60371-489-8

Forel Publishing Company, LLC
Woodbridge, VA 22192
Email: sales@ForelPublishing.com
<https://www.ForelPublishing.com>



License #84356800

This publication contains material that is reproduced and distributed under a license from Ford Motor Company. No further reproduction or distribution of the Ford Motor Company material is allowed without the express written permission of Ford Motor Company.

Note from the Publisher

This product was created from the original Ford Motor Company's publication. Every effort has been made to use the original scanned images, however, due to the condition of the material; some pages have been modified to remove imperfections.

Disclaimer

Although every effort was made to ensure the accuracy of this book, no representations or warranties of any kind are made concerning the accuracy, completeness or suitability of the information, either expressed or implied. As a result, the information contained within this book should be used as general information only. The author and Forel Publishing Company, LLC shall have neither liability nor responsibility to any person or entity with respect to any loss or damage caused, or alleged to be caused, directly or indirectly by the information contained in this book. Further, the publisher and author are not engaged in rendering legal or other professional services. If legal, mechanical, electrical, or other expert assistance is required, the services of a competent professional should be sought.



2002 Workshop Manual



License #84356800



F-150

VOLUME 1



BUY IT NOW!

Click Here To Order



Motor Company



2002 F-150

TABLE OF CONTENTS

INTRODUCTION

GENERAL INFORMATION..... Volume 1

SERVICE INFORMATION

Identification Codes.....	100-01
Jacking and Lifting.....	100-02
Noise, Vibration and Harshness.....	100-04

CHASSIS..... Volume 1

SUSPENSION

Suspension System — General Information.....	204-00
Front Suspension — 4x2.....	204-01A
Front Suspension — 4x4.....	204-01B
Rear Suspension.....	204-02
Wheels and Tires.....	204-04

DRIVELINE

Driveline System — General Information.....	205-00
Driveshaft.....	205-01
Rear Drive Axle/Differential — Ford	
8.8-Inch Ring Gear.....	205-02A
Rear Drive Axle/Differential — Ford	
9.75-Inch Ring Gear.....	205-02B
Rear Drive Axle/Differential — Ford	
10.25-Inch Ring Gear.....	205-02C
Front Drive Axle/Differential — Ford	
8.8-Inch Ring Gear.....	205-03
Front Drive Halfshafts.....	205-04

BRAKE SYSTEM

Brake System — General Information.....	206-00
Drum Brake.....	206-02
Front Disc Brake.....	206-03
Rear Disc Brake.....	206-04
Parking Brake and Actuation.....	206-05
Hydraulic Brake Actuation.....	206-06
Power Brake Actuation.....	206-07
Anti-Lock Control — Rear.....	206-09A
Anti-Lock Control — 4-Wheel.....	206-09B

STEERING SYSTEM

Steering System — General Information.....	211-00
Power Steering.....	211-02
Steering Linkage.....	211-03
Steering Column.....	211-04
Steering Column Switches.....	211-05

POWERTRAIN..... Volume 2

ENGINE

Engine System — General Information.....	303-00
Engine — 4.2L.....	303-01A
Engine — 4.6L and 5.4L.....	303-01B
Engine Cooling.....	303-03A
Supercharger Cooling.....	303-03B
Fuel Charging and Controls — 4.2L.....	303-04A
Fuel Charging and Controls —	
4.6L (2V) and 5.4L (2V).....	303-04B
Fuel Charging and Controls —	
Natural Gas Vehicle.....	303-04C
Fuel Charging and Controls —	
Bi-Fuel Vehicles.....	303-04D
Accessory Drive.....	303-05
Starting System.....	303-06
Engine Ignition — 4.2L.....	303-07A
Engine Ignition — 4.6L (2V) and 5.4L (2V).....	303-07B
Engine Emission Control.....	303-08
Intake Air Distribution and Filtering.....	303-12
Evaporative Emissions.....	303-13
Electronic Engine Controls.....	303-14

AUTOMATIC TRANSMISSION

Automatic Transmission — 4R100.....	307-01A
Automatic Transmission — 4R70W.....	307-01B
Transaxle/Transmission Cooling.....	307-02
Automatic Transaxle/Transmission	
External Controls.....	307-05

NOTE: The descriptions and specifications contained in this manual were in effect at the time this manual was approved for printing. Ford Motor Company reserves the right to discontinue models at any time, or change specifications or design without notice and without incurring any obligation.

PUBLICATIONS ORDERING INFORMATION

To obtain information about ordering additional copies of this publication or to order any other Ford or Lincoln/Mercury publications, call 1-800-556-5656. Available publications include workshop manuals, wiring diagrams, PC/ED Manuals and Owner Guides.

Form by writing to: Ford Publications, care of Helm Inc., P.O. Box 07150, Detroit, MI 48207.

Reproduction, electronic or mechanical, including photocopying, recording, or by any information storage and retrieval system, is not permitted without written authorization from Ford Motor Company.



BUY IT NOW!

Click Here To Order





2002 F-150

TABLE OF CONTENTS

MANUAL TRANSMISSION, CLUTCH AND TRANSFER CASE

Manual Transaxle/Transmission and Clutch —	
General Information	308-00
Clutch	308-01
Clutch Controls	308-02
Manual Transaxle/Transmission	308-03
Transfer Case — General Information	308-07A
Transfer Case	308-07B

EXHAUST SYSTEM

Exhaust System	309-00
----------------------	--------

FUEL SYSTEM

Fuel System — General Information	310-00A
Fuel System — General Information —	
Natural Gas	310-00B
Fuel System — General Information —	
Bi-Fuel Vehicles	310-00C
Fuel Tank and Lines	310-01A
Fuel Tank and Lines — Natural Gas	310-01B
Fuel Tank and Lines — Bi-Fuel Vehicles	310-01C
Acceleration Control	310-02
Vehicle Speed Control	310-03

ELECTRICAL Volume 1

CLIMATE CONTROL SYSTEM

Climate Control System — General Information	412-00
Air Distribution and Filtering	412-01
Heating and Ventilation	412-02
Air Conditioning	412-03
Control Components	412-04

INSTRUMENTATION AND WARNING SYSTEMS

Instrument Cluster and Panel Illumination	413-00
Instrument Cluster — Conventional	413-01A
Instrument Cluster — Natural Gas Vehicle	413-01B
Instrument Cluster — Bi-Fuel Vehicles	413-01C
Horn	413-06
Warning Devices	413-09

BATTERY AND CHARGING SYSTEM

Charging System — General Information	414-00
Battery, Mounting and Cables	414-01
Generator and Regulator	414-02

AUDIO SYSTEMS

Entertainment System — General Information	415-00
Audio Unit	415-01
Antenna	415-02
Speakers	415-03
Video System	415-07

LIGHTING

Exterior Lighting	417-01
Interior Lighting	417-02
Daytime Running Lamps	417-04

ELECTRICAL DISTRIBUTION

Module Communications Network	418-00
Module Configuration	418-01

ELECTRONIC FEATURE GROUP

Anti-Theft — PATS	419-01
Remote Convenience	419-02
Multifunction Electronic Control Modules	419-10
Electronic Compass	419-11

BODY AND PAINT Volume 1

BODY

Body System — General Information	501-00
Front End Body Panels	501-02
Body Closures	501-03
Pickup Bed and Platform Body	501-04
Interior Trim and Ornamentation	501-05
Exterior Trim and Ornamentation	501-08
Rear View Mirrors	501-09
Seating	501-10
Glass, Frames and Mechanisms	501-11
Instrument Panel and Console	501-12
Handles, Locks, Latches and Entry Systems	501-14
Wipers and Washers	501-16
Roof Opening Panel	501-17
Bumpers	501-19
Occupant Restraints — Active	501-20A
Occupant Restraints — Passive —	
Supplemental Air Bag System	501-20B

FRAME AND MOUNTING

Full Frame and Body Mounting	502-02
------------------------------------	--------

INDEX

100% SATISFACTION GUARANTEED

BUY IT NOW!

Click Here To Order

INTRODUCTION

NOTE: The descriptions and specifications contained in this manual were in effect at the time this manual was approved for printing. Ford Motor Company reserves the right to discontinue models at any time, or change specifications or design without notice and without incurring any obligation.

IMPORTANT SAFETY NOTICE

Appropriate service methods and procedures are essential for the safe, reliable operation of all motor vehicles as well as the personal safety of the individual doing the work. This manual provides general directions for performing service with tested, effective techniques. Following them will help assure reliability.

There are numerous variations in procedure, techniques, tools and parts for servicing vehicles, as well as in the skill of the individual doing the work. This manual cannot possibly anticipate all such variations and provide advice or cautions as to each. Accordingly, anyone who departs from the instructions provided in this manual must first establish that he compromises neither his personal safety nor the vehicle integrity by his choice of methods, tools or parts.

NOTES, CAUTIONS, AND WARNINGS

As you read through the procedures, you will come across **NOTES**, **CAUTIONS**, and **WARNINGS**. Each one is there for a specific purpose. **NOTES** give you added information that will help you to perform a particular procedure. **CAUTIONS** are given to prevent you from making an error that could damage the vehicle. **WARNINGS** remind you to be especially careful in those areas where carelessness can cause you personal injury. The following list contains some general **WARNINGS** that you should follow when you work on a vehicle.

- **ALWAYS WEAR SAFETY GLASSES FOR EYE PROTECTION.**
- **USE SAFETY STANDS WHENEVER A PROCEDURE REQUIRES YOU TO BE UNDER THE VEHICLE.**
- **MAKE SURE THAT THE IGNITION SWITCH IS ALWAYS IN THE OFF POSITION, UNLESS OTHERWISE REQUIRED BY THE PROCEDURE.**
- **SET THE PARKING BRAKE WHEN WORKING ON THE VEHICLE. IF YOU HAVE AN AUTOMATIC TRANSMISSION, SET IN PARK UNLESS INSTRUCTED OTHERWISE FOR A SPECIFIC OPERATION. IF YOU HAVE A MANUAL TRANSMISSION, IT SHOULD BE IN REVERSE (ENGINE OFF) OR NEUTRAL (ENGINE ON) UNLESS INSTRUCTED OTHERWISE FOR A SPECIFIC OPERATION. PLACE WOOD BLOCKS (4" X 4" OR LARGER) AGAINST THE FRONT AND REAR SURFACES OF THE TIRES TO HELP PREVENT THE VEHICLE FROM MOVING.**
- **OPERATE THE ENGINE ONLY IN A WELL-VENTILATED AREA TO AVOID THE DANGER OF CARBON MONOXIDE POISONING.**
- **KEEP YOURSELF AND YOUR CLOTHING AWAY FROM MOVING PARTS WHEN THE ENGINE IS RUNNING, ESPECIALLY THE DRIVE BELTS.**
- **TO PREVENT SERIOUS BURNS, AVOID CONTACT WITH HOT METAL PARTS SUCH AS THE RADIATOR, EXHAUST MANIFOLD, TAIL PIPE, THREE-WAY CATALYTIC CONVERTER AND MUFFLER.**
- **DO NOT SMOKE WHILE WORKING ON A VEHICLE.**
- **TO AVOID INJURY, ALWAYS REMOVE RINGS, WATCHES, LOOSE HANGING JEWELRY AND LOOSE CLOTHING BEFORE BEGINNING TO WORK ON A VEHICLE.**
- **WHEN IT IS NECESSARY TO WORK UNDER THE HOOD, KEEP HANDS AND OTHER OBJECTS CLEAR OF FANS!**



BUY IT NOW!

Click Here To Order



General Information

GROUP **1**

SECTION TITLE	PAGE
Identification Codes	100-01-1
Jacking and Lifting	100-02-1
Noise, Vibration and Harshness	100-04-1

SECTION 100-01 Identification Codes

CONTENTS	PAGE
DESCRIPTION AND OPERATION	
Identification Codes	100-01-2



BUY IT NOW!
Click Here To Order 



DESCRIPTION AND OPERATION

Identification Codes

The vehicle identification number (VIN) is a 17-digit combination of letters and numbers. The VIN is stamped on a metal tab riveted to the instrument panel, top upper left of the dash. The VIN number is also found on the vehicle certification (VC) label.

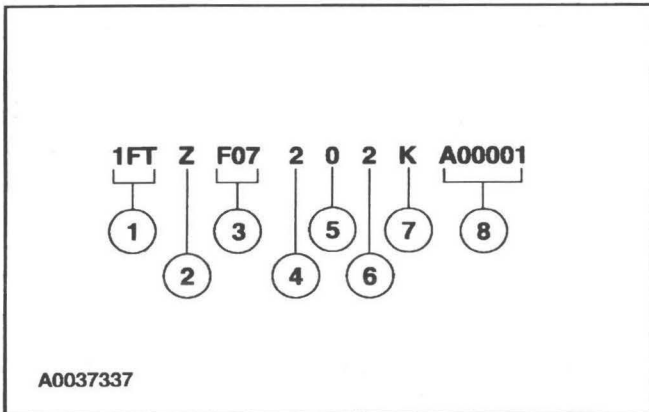

Item	Description
1	World manufacturer identifier (WMI)
2	Brake type and gross vehicle weight rating (GVWR), may also include the vehicle restraint type code
3	Vehicle line, series, body type code
4	Engine type code
5	Computer-generated check digit
6	Model year code
7	Assembly plant code
8	Production sequence number

Vehicle Identification Number

World Manufacturer Identifier

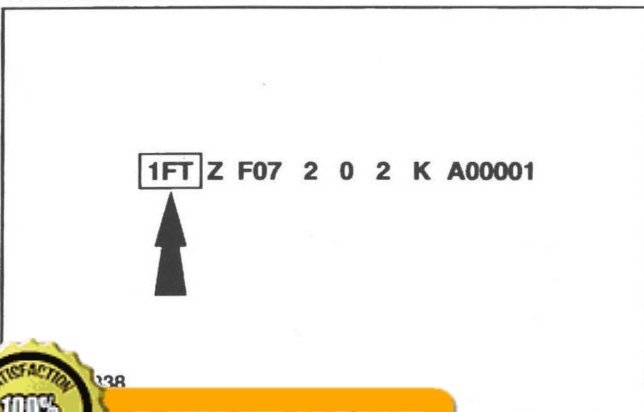

The first three vehicle identification number (VIN) positions are the world manufacturer identifier.

- 1FT — Ford Motor Company, USA, truck, completed vehicle
- 2FT — Ford Motor Company, Canada, truck, completed vehicle
- 3FT — Ford Motor Company, Mexico, truck, completed vehicle

Brake and Gross Vehicle Weight Code

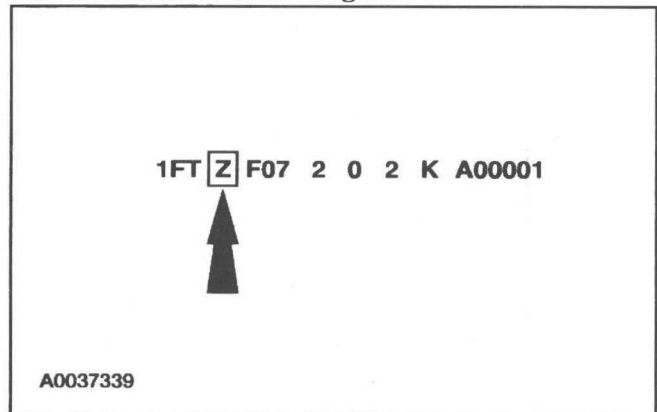

The fourth VIN position is the vehicle brake type and GVWR code (all vehicles use hydraulic brakes).

- Z — 5,001-6,000 pounds GVWR with driver and front passenger air bags
- R — 6,001-7,000 pounds GVWR with driver and front passenger air bags
- P — 7,001-8,000 pounds GVWR with driver and front passenger air bags

Line, Series and Body Type

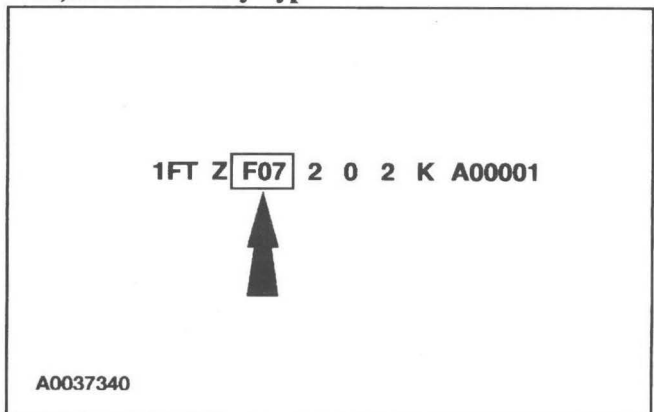

100% SATISFACTION GUARANTEED

BUY IT NOW!

Click Here To Order

DESCRIPTION AND OPERATION (Continued)

Positions 5 through 7 indicate vehicle line, series and body type.

- F07 — Regular Cab, 4x2, Flareside
- X07 — SuperCab, 4x2, Flareside
- F08 — Regular Cab, 4x4, Flareside
- X08 — SuperCab, 4x4, Flareside
- F17 — Regular Cab, 4x2, Styleside
- X17 — SuperCab, 4x2, Styleside
- F18 — Regular Cab, 4x4, Styleside
- X18 — SuperCab, 4x4, Styleside
- W07 — Crew Cab, 4x2, Flareside
- W08 — Crew Cab, 4x4, Flareside

- M — 5.4L, SOHC, V8, Natural Gas
- Z — 5.4L, Bi-Fuel, V8 (Natural Gas/Propane)
- 3 — 5.4L, SOHC, V8, Gas (Lightning)

Engine Code

1FT Z F07 2 0 2 K A00001

↑

A0037341

The eighth VIN position is the engine displacement and number of cylinders.

- 2 — 4.2L, OHV, V6, Gas
- W — 4.6L, SOHC, V8, Gas
- L — 5.4L, SOHC, V8, Gas

Check Digit

1FT Z F07 2 0 2 K A00001

↑

A0037342

The ninth VIN position is a government assigned, computer-generated check digit.

Model Year

1FT Z F07 2 0 2 K A00001

↑

A0037343

100% SATISFACTION GUARANTEED

BUY IT NOW!

Click Here To Order

DESCRIPTION AND OPERATION (Continued)

The tenth VIN position is the model year code.

- 2 — 2002

Assembly Plant Code

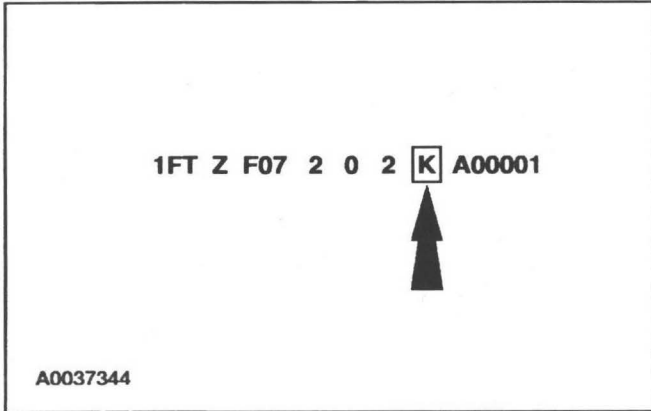

The eleventh VIN position is the assembly plant code.

- C — Ontario Truck (Oakville, Ontario)
- K — Kansas City (Claycomo, Missouri)
- N — Norfolk (Norfolk, Virginia)
- M — Cuautitlan (Cuautitlan, Mexico)

Vehicle Serial Number

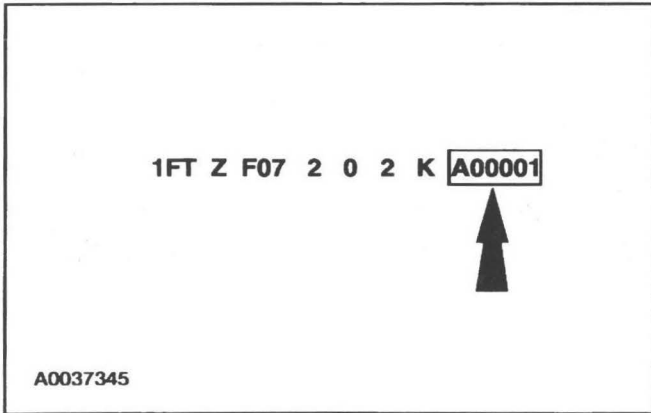

The last six VIN positions are an alphanumeric code for the vehicle build sequence. This is also the vehicle serial and warranty number.

Vehicle Certification (VC) Label

MFD. BY FORD MOTOR CO. IN U.S.A.

DATE: 01/98 GVWR: XXXXXXXXXXXXXXXX
 FRONT GAWR: XXXXXXXX REAR GAWR: XXXXXXXX
 WITH XXXXXXXX WITH XXXXXXXX
 XXXXXXXXXXXXXXXX TIRES XXXXXXXXXXXXXXXX TIRES
 XXXXXXXX RIMS XXXXXXXX RIMS
 AT XXXX kPa/XXX PSI COLD AT XXXX kPa/XXX PSI COLD
 XXXX

THIS VEHICLE CONFORMS TO ALL APPLICABLE FEDERAL MOTOR VEHICLE SAFETY STANDARDS IN EFFECT ON THE DATE OF MANUFACTURE SHOWN ABOVE.

VIN: XXXXXXXXXXXXXXXXXXXX
 TYPE: XXXXXXXXXXXXXXXXXXXX

EXT PNT: XXXXXXXX XXXXXXXX RC: XX DSO: XXXX
 WB | BRK | INT | TR | TP/PS | R | AXLE | TR | SPR | XXXX
 XXX | X | XX | XXX | X | XX | X | XXXX | XXXX
 ↑ ↑ ↑ UTC ↑ ↑ ↑ ↑ ↑ ↑ ↑ AB

A0008272

Item	Description
1	Exterior paint code
2	Region code
3	Domestic special order (DSO) code
4	Wheelbase code
5	Brake type code
6	Interior trim code
7	Tape/paint stripe code
8	Radio code
9	Axle code

(Continued)



DESCRIPTION AND OPERATION (Continued)

Item	Description
10	Transmission code
11	Spring code
12	Powertrain calibration information

The vehicle certification (VC) label contains the manufacturer name, the month and year of manufacture, the certification statement, and the VIN. It also includes gross vehicle weight ratings (GVWR).

Vehicle Certification (VC) Label — Canada (Typical)

MFD. BY FORD MOTOR CO. OF CANADA, LTD.
 DATE: 01/98
 GVWR/PNBV: XXXXXXXXXXXXXXXX
 FRONT GAWR / REAR GAWR
 PNBE AV PNBE AR
 XXXXXXXX XXXXXXXX
 XXXXXXXX XXXXXXXX
 WITH/AVEC TIRES/PNEUS
 XXXXXXXXXXXXXXXX / XXXXXXXXXXXXXXXX
 XXXXXXXXXXXX RIMS/JANTES XXXXXXXXXXXX
 AT/A kPa/PSI/LPC XXXXX/XXX COLD/A FROID XXXX/XXX
 XXXX/JUMELÉES
 VIN: XXXXXXXXXXXXXXXX XXXXX
 TYPE: XXXXXXXXXXXXXXXX COMPLIES: ICES-2 XXXXX





EXT PNT: XXXXXX XXXXXX | RC: XX | DSO: XXXX
 WB | BRK | INT | TR | TP/PS | R | AXLE | TR | SPR | XXXXX
 XXX X XX XXX X XX X XXXXX XXXXX
 A0008273 MADE IN CANADA CCT ∇ F85B-1520472-AB

Vehicle Certification (VC) Label — Mexico (Typical)

MFD. BY FORD MOTOR COMPANY
 DATE: XXXXX GVWR: XXXXXXXXXXXXXXXX
 FRONT GAWR: XXXXXXXX XXXXXXXX
 REAR GAWR: XXXXXXXX XXXXXXXX

 VIN: XXXXXXXXXXXXXXXX XXXXX
 TYPE: XXXXXXXXXXXXXXXX XXXXX



EXT PNT: XXXXXX XXXXXX | RC: XX | DSO: XXXX
 WB | BRK | INT | TR | TP/PS | R | AXLE | TR | SPR | XXXXX
 XXX X XX XXX X XX X XXXXX XXXXX
 A0008274 MADE IN MEXICO MPE ∇ F85B-1520472-AB

Exterior Paint

MFD. BY FORD MOTOR CO. IN U.S.A.

DATE: 01/98 GVWR: XXXXXXXXXXXXXXXX
 FRONT GAWR: XXXXXXXX REAR GAWR: XXXXXXXX
 XXXXXXXX WITH XXXXXXXX WITH
 XXXXXXXXXXXXXXXX TIRES XXXXXXXXXXXXXXXX TIRES
 XXXXXXXX RIMS XXXXXXXX RIMS
 AT XXXX kPa/XXX PSI COLD AT XXXX kPa/XXX PSI COLD
 XXXX

THIS VEHICLE CONFORMS TO ALL APPLICABLE FEDERAL MOTOR VEHICLE SAFETY STANDARDS IN EFFECT ON THE DATE OF MANUFACTURE SHOWN ABOVE.
 VIN: XXXXXXXXXXXXXXXX
 TYPE: XXXXXXXXXXXXXXXX



EXT PNT: XXXXXX XXXXXX | RC: XX | DSO: XXXX
 WB | BRK | INT | TR | TP/PS | R | AXLE | TR | SPR | XXXXX
 XXX X XX XXX X XX X XXXXX XXXXX
 UTC ∇ F85B-1520472-AB

A0018017

Paint Codes

Exterior paint color codes may be listed as a two-part code. The first set of paint code characters indicate the primary body color. The second set of paint code characters (if applicable), indicate a two-tone body color or accent body color.



BUY IT NOW!
 Click Here To Order



DESCRIPTION AND OPERATION (Continued)

Primary Body Color

- E4 — Vermilion, clear coat
- B4 — Chestnut, clear coat
- FL — Medium Toreador Red, clear coat
- YN — Silver Metallic, clear coat
- UA — Ebony, clear coat
- YZ — Oxford White, clear coat
- Y1 — Prime
- AQ — Arizona Beige
- PX — Dark Highland Green
- ST — Estate Green (King Ranch)
- KW — Charcoal Blue (King Ranch)
- L2 — True Blue
- CX — Dark Shadow Gray

- 120 — 120-inch wheelbase, regular cab
- 139 — 139-inch wheelbase, regular cab, SuperCab, Crew Cab
- 157 — 157-inch wheelbase, SuperCab

Wheelbase

MFD. BY FORD MOTOR CO. IN U.S.A.

DATE: 01/98	GWWR: XXXXXXXXXXXXXXXX
FRONT GAWR: XXXXXXXX	REAR GAWR: XXXXXXXX
XXXXXXXXXX WITH XXXXXXXX WITH	XXXXXXXXXX WITH XXXXXXXX WITH
XXXXXXXXXXXXX TIRES XXXXXXXXXXXXX TIRES	XXXXXXXXXXXXX TIRES XXXXXXXXXXXXX TIRES
XXXXXXXXXXXXX RIMS XXXXXXXXXX RIMS	XXXXXXXXXXXXX RIMS XXXXXXXXXX RIMS
AT XXXX kPa/XXX PSI COLD	AT XXXX kPa/XXX PSI COLD

THIS VEHICLE CONFORMS TO ALL APPLICABLE FEDERAL MOTOR VEHICLE SAFETY STANDARDS IN EFFECT ON THE DATE OF MANUFACTURE SHOWN ABOVE.

VIN: XXXXXXXXXXXXXXXXXXXX XXXXX
 TYPE: XXXXXXXXXXXXXXXXXXXX XXXXX



EXT PNT: XXXXXXXX XXXXXXXX	RC: XX	DSO: XXXX
WB BRK INT TR TP/PS R AXLE TR SPR XXXXX		
XXX X XX XXX X XX X XXXXX XXXXX		
	UTC	∇ F85B-1520472-AB

↑

A0018018

Brake Type

MFD. BY FORD MOTOR CO. IN U.S.A.

DATE: 01/98	GWWR: XXXXXXXXXXXXXXXX
FRONT GAWR: XXXXXXXX	REAR GAWR: XXXXXXXX
XXXXXXXXXX WITH XXXXXXXX WITH	XXXXXXXXXX WITH XXXXXXXX WITH
XXXXXXXXXXXXX TIRES XXXXXXXXXXXXX TIRES	XXXXXXXXXXXXX TIRES XXXXXXXXXXXXX TIRES
XXXXXXXXXXXXX RIMS XXXXXXXXXX RIMS	XXXXXXXXXXXXX RIMS XXXXXXXXXX RIMS
AT XXXX kPa/XXX PSI COLD	AT XXXX kPa/XXX PSI COLD

THIS VEHICLE CONFORMS TO ALL APPLICABLE FEDERAL MOTOR VEHICLE SAFETY STANDARDS IN EFFECT ON THE DATE OF MANUFACTURE SHOWN ABOVE.

VIN: XXXXXXXXXXXXXXXXXXXX XXXXX
 TYPE: XXXXXXXXXXXXXXXXXXXX XXXXX



EXT PNT: XXXXXXXX XXXXXXXX	RC: XX	DSO: XXXX
WB BRK INT TR TP/PS R AXLE TR SPR XXXXX		
XXX X XX XXX X XX X XXXXX XXXXX		
	UTC	∇ F85B-1520472-AB

↑

A0018019

- B — Four-wheel anti-lock brake system (ABS)



BUY IT NOW!

[Click Here To Order](#)



DESCRIPTION AND OPERATION (Continued)

Interior Trim

MFD. BY FORD MOTOR CO. IN U.S.A.

DATE: 01/98 GVWR: XXXXXXXXXXXXXXXX
 FRONT GAWR: XXXXXXX REAR GAWR: XXXXXXX
 XXXXXXXX WITH XXXXXXXX WITH
 XXXXXXXXXXXXXXXX TIRES XXXXXXXXXXXXXXXX TIRES
 XXXXXXXX RIMS XXXXXXXX RIMS
 AT XXXX kPa/XXX PSI COLD AT XXXX kPa/XXX PSI COLD
XXXX

THIS VEHICLE CONFORMS TO ALL APPLICABLE FEDERAL MOTOR VEHICLE SAFETY STANDARDS IN EFFECT ON THE DATE OF MANUFACTURE SHOWN ABOVE.
 VIN: XXXXXXXXXXXXXXXX XXXXX
 TYPE: XXXXXXXXXXXXXXXX XXXXX



EXT PNT: XXXXXXXX XXXXXXXX		RC: XX	DSO: XXXX						
WB	BRK	INT	TR	TP/PS	R	AXLE	TR	SPR	XXXXX
XXX	X		XX	XXX	X	XX	X	XXXXX	XXXXX

UTC ▽ F85B-1520472-AB

↑

A0018020

Interior trim codes are listed as a two-part code. The first character identifies the interior trim type. The second character identifies the interior trim color.

Interior Trim Type

- A — Vinyl full bench split-back
- C — Poly knit full bench
- F — Cloth captains chairs with console
- H — Leather captains chairs with console
- M — Cloth 40/60
- E — Leather 40/60
- L — Cloth/leather (Lightning)
- S — 60/40 split bench (Sport)
- T — Captains chairs (Sport)
- D — Leather captains chairs (Harley-Davidson edition)
- K — Leather captains chairs (King Ranch)

Interior Color Code

- T — Dark Graphite
- 2 — Medium Graphite
- H — Medium Parchment
- B — Ebony

Tape/Paint Stripe

MFD. BY FORD MOTOR CO. IN U.S.A.

DATE: 01/98 GVWR: XXXXXXXXXXXXXXXX
 FRONT GAWR: XXXXXXX REAR GAWR: XXXXXXX
 XXXXXXXX WITH XXXXXXXX WITH
 XXXXXXXXXXXXXXXX TIRES XXXXXXXXXXXXXXXX TIRES
 XXXXXXXX RIMS XXXXXXXX RIMS
 AT XXXX kPa/XXX PSI COLD AT XXXX kPa/XXX PSI COLD
XXXX

THIS VEHICLE CONFORMS TO ALL APPLICABLE FEDERAL MOTOR VEHICLE SAFETY STANDARDS IN EFFECT ON THE DATE OF MANUFACTURE SHOWN ABOVE.
 VIN: XXXXXXXXXXXXXXXX XXXXX
 TYPE: XXXXXXXXXXXXXXXX XXXXX



EXT PNT: XXXXXXXX XXXXXXXX		RC: XX	DSO: XXXX						
WB	BRK	INT	TR	TP/PS	R	AXLE	TR	SPR	XXXXX
XXX	X		XX	XXX	X	XX	X	XXXXX	XXXXX

UTC ▽ F85B-1520472-AB

↑

A0018021

- A — Light Argent/Medium Platinum
- B — Arizona Beige/Deep Sandlewood Metallic
- Z — NASCAR tapestripes
- O — Orange (Harley-Davidson edition)
- X — Tapestripe delete
- C — Light Argent/Medium Platinum (Lariat)
- D — Medium Platinum/Light Argent (Lariat)



BUY IT NOW!

Click Here To Order



DESCRIPTION AND OPERATION (Continued)

- E — Arizona Beige/Deep Sandlewood Metallic (Lariat)
- F — Deep Sandlewood Metallic/Arizona Beige (Lariat)

- E — Delete radio chassis only (AM/FM premium stereo with clock and compact disc (CD) player)
- R — Delete radio chassis only (AM/FM stereo with clock and cassette)

Radio Type

Axle Type

MFD. BY FORD MOTOR CO. IN U.S.A.

DATE: 01/98 GVWR: XXXXXXXXXXXXXXXX
 FRONT GAWR: XXXXXXXX REAR GAWR: XXXXXXXX
 XXXXXXXX WITH XXXXXXXX WITH
 XXXXXXXXXXXXXXXX TIRES XXXXXXXXXXXXXXXX TIRES
 XXXXXXXX RIMS XXXXXXXX RIMS
 AT XXXX kPa/XXX PSI COLD AT XXXX kPa/XXX PSI COLD
XXXX

THIS VEHICLE CONFORMS TO ALL APPLICABLE FEDERAL MOTOR VEHICLE SAFETY STANDARDS IN EFFECT ON THE DATE OF MANUFACTURE SHOWN ABOVE.
 VIN: XXXXXXXXXXXXXXXX XXXXX
 TYPE: XXXXXXXXXXXXXXXX XXXXX

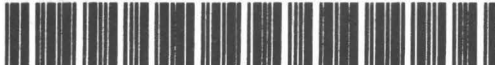

EXT PNT: XXXXXXXX XXXXXXXX		RC: XX	DSO: XXXX						
WB	BRK	INT	TR	TP/PS	R	AXLE	TR	SPR	XXXXX
XXX	X		XX	XXX	X	XX	X	XXXXX	XXXXX

↑ UTC
↑ UTC

▽ F85B-1520472-AB

A0018022

MFD. BY FORD MOTOR CO. IN U.S.A.

DATE: 01/98 GVWR: XXXXXXXXXXXXXXXX
 FRONT GAWR: XXXXXXXX REAR GAWR: XXXXXXXX
 XXXXXXXX WITH XXXXXXXX WITH
 XXXXXXXXXXXXXXXX TIRES XXXXXXXXXXXXXXXX TIRES
 XXXXXXXX RIMS XXXXXXXX RIMS
 AT XXXX kPa/XXX PSI COLD AT XXXX kPa/XXX PSI COLD
XXXX

THIS VEHICLE CONFORMS TO ALL APPLICABLE FEDERAL MOTOR VEHICLE SAFETY STANDARDS IN EFFECT ON THE DATE OF MANUFACTURE SHOWN ABOVE.
 VIN: XXXXXXXXXXXXXXXX XXXXX
 TYPE: XXXXXXXXXXXXXXXX XXXXX



EXT PNT: XXXXXXXX XXXXXXXX		RC: XX	DSO: XXXX						
WB	BRK	INT	TR	TP/PS	R	AXLE	TR	SPR	XXXXX
XXX	X		XX	XXX	X	XX	X	XXXXX	XXXXX

↑ UTC
↑ UTC

▽ F85B-1520472-AB

A0018023

- 9 — AM/FM stereo with clock and cassette (Mexico)
- 5 — AM/FM premium stereo with clock and compact disc (CD) player
- 8 — AM/FM premium stereo with compact disc (CD) changer and cassette
- Y — Delete standard AM radio with clock
- D — Delete radio chassis only (AM/FM stereo with compact disc (CD) changer and cassette)

- 18 — 3.08, non-limited slip
- 19 — 3.55, non-limited slip
- 26 — 3.73, non-limited slip
- 27 — 3.31, non-limited slip
- H9 — 3.55, limited slip
- B6 — 3.73, limited slip
- B5 — 4.10, limited slip

100% SATISFACTION GUARANTEED

BUY IT NOW!

Click Here To Order



DESCRIPTION AND OPERATION (Continued)

Front Springs

- Base part number — 5310

Front Torsion Bars

- Base part number — 5B326 (right-hand), 5B327 (left-hand)

Rear Springs

- Base part number — 5560

Powertrain Calibration Information

MFD. BY FORD MOTOR CO. IN U.S.A.

DATE: 01/98 GVWR: XXXXXXXXXXXXXXXX
 FRONT GAWR: XXXXXXXX REAR GAWR: XXXXXXXX
 XXXXXXXX WITH XXXXXXXX WITH
 XXXXXXXXXXXXXXXX TIRES XXXXXXXXXXXXXXXX TIRES
 XXXXXXXX RIMS XXXXXXXX RIMS
 AT XXXX kPa/XXX PSI COLD AT XXXX kPa/XXX PSI COLD
 XXXX

THIS VEHICLE CONFORMS TO ALL APPLICABLE FEDERAL MOTOR
 VEHICLE SAFETY STANDARDS IN EFFECT ON THE DATE OF
 MANUFACTURE SHOWN ABOVE.
 VIN: XXXXXXXXXXXXXXXX
 TYPE: XXXXXXXXXXXXXXXX



XXXX
XXXX

EXT	PNT:	XXXXXX	XXXXXX	RC:	XX	DSO:	XXXX
WB	BRK	INT	TR	TP/PS	R	AXLE	TR
XXX	X	XX	XXX	X	XX	X	XXXX
UTC							1520472-AB

A0010077

NOTE: Powertrain calibration information is limited to a maximum of five characters per line on the vehicle certification label. Because of this, calibration identification consisting of more than five characters will wrap to the second line on the VC label.

Powertrain calibration information is printed in the lower right corner of the vehicle certification label. Only the base calibration information is printed. Revision levels will not appear, however, they can be found in On Line Automotive Service Information System (OASIS). For the current model year, Ford Motor Company is using three different protocols which describe powertrain base calibration. These protocols are designed to provide worldwide standardization for vehicle calibration. If the electronic calibration strategy was introduced in 1998 and carried into the current model year, Protocol 1 will be used. Refer to Protocol 1 below. If the electronic calibration strategy was introduced in 1999 and is carried into the current model year, Protocol 2 will be used. Refer to Protocol 2 below. For new electronic calibration strategies introduced in 2000 or 2001 use Protocol 3. Refer to Protocol 3 below.

Protocol 1

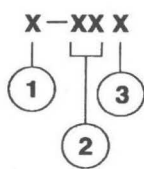

A0008982

100% SATISFACTION GUARANTEED

BUY IT NOW!

Click Here To Order



DESCRIPTION AND OPERATION (Continued)

Item	Description
1	Model year (model year in which calibration strategy was first introduced)
2	Engine code
3	Engine revision level

Protocol 2

X XX X - X X

A0008983

Item	Description
1	Model year (model year in which calibration strategy was first introduced)
2	Engine code
3	Transmission code
4	Emission standard (designates the specific country emission standard)
5	Design level (design level assigned to the engine)

Protocol 3

X XX X XX X X XX

A0008984

Item	Description
1	Model year (model year in which calibration strategy was first introduced)

Item	Description
3	Transmission code
4	Unique calibration (designates different hardware to similar vehicles). Example: tires, drive ratios, etc.
5	Fleet code (describes fleet to which the vehicle belongs). Example: 6 - evaporative emissions
6	Certification region (lead region where multiple regions are included in one calibration). Example: A - U.S. federal
7	Revision level (will advance as revisions occur). Not printed on label

Protocol 3

The following offers a more detailed explanation of the coding strategy used in Protocol 3.

Model Year

- 0 — 2000
- 1 — 2001
- 2 — 2002

Vehicle Line

- F5 — F-150

Transmission

- 1 — Automatic transmission
- 2 — Manual transmission

Unique Calibration

The Emissions/CAFE/CO2 Compliance Department is responsible for assigning these calibration numbers. Unique calibration identification identifications are assigned to cover similar vehicles to differentiate tires, drive configurations, final drive ratios and other calibration-significant factors.

These two characters are chosen by the analyst to provide identifiable information unique to each calibration. For example, using the number 2 to denote a two-valve engine versus using the number 4 to denote a four-valve engine, offers an easily identifiable difference.

Fleet Code

- 1 — HDGE/Dyno
- 2 — Fast AMA, U.S.
- 3 — ADP, U.S.
- 4 — Not assigned
- 5 — Not assigned



BUY IT NOW!

Click Here To Order



DESCRIPTION AND OPERATION (Continued)

- 6 — Evaporative emissions
- 7 — MACAA
- 8 — On-board diagnostics (OBD)
- 9 — Not assigned

Certification Region

Where multiple regions are included in one calibration, only the lead region will be listed.

- 5 — U.S. fifty states
- A — U.S. federal, including altitude, may include Canada and/or Mexico
- B — U.S. California standard, includes U.S. green states
- C — Canada
- D — China
- E — European Community (Austria, Belgium, Denmark, Finland, France, Germany, Greece, Ireland, Italy, Luxembourg, Netherlands, Portugal, Spain, Sweden and United Kingdom)
- F — Extended European Community (E plus Croatia, Czech Republic, Estonia, Hungary, Norway, Poland, Romania, Russian Federation, Slovakia, Slovenia, Switzerland and Yugoslavia)
- G — Gulf Cooperative Council (Bahrain, Kuwait, Oman, Qatar, Saudi Arabia and UAE)
- H — Hong Kong

- J — Japan
- K — Korea
- L — Malaysia
- M — Mexico
- N — New Zealand
- P — Australia
- Q — South America (Brazil)
- S — Singapore
- T — Taiwan
- U — South America (unleaded fuel regions)
- V — Vietnam
- Y — Military
- Z — Israel

Revision Level (not printed on label)

- 91-99 — Hardware calibration levels
- 01-04 — Preliminary levels
- 00 — Job 1 production (initial calibration)
- 05-09 — Pre-job 1 revisions to calibrations
- 10-89 — Post-job 1 revisions to calibrations
- 0B — Durability test level
- BD — On-board diagnostics (OBD) intermediate level (pre-05)



100% SATISFACTION GUARANTEED

BUY IT NOW!

Click Here To Order





SECTION 100-02 Jacking and Lifting

CONTENTS	PAGE
DESCRIPTION AND OPERATION	
Jacking.....	100-02-2
Lifting.....	100-02-3
Lifting Points — Twin Post Hoist.....	100-02-3

100% SATISFACTION GUARANTEED

BUY IT NOW!

Click Here To Order

PayPal American Express Cards DISCOVER NEW! MasterCard VISA

DESCRIPTION AND OPERATION

Jacking

⚠ WARNING: The electrical power to the air suspension system must be shut down prior to hoisting, jacking or towing an air suspension vehicle. This can be accomplished by turning off the air suspension switch located in the RH kick panel area. Failure to do so may result in unexpected inflation or deflation of the air springs which may result in shifting of the vehicle during these operations.

⚠ WARNING: Do not run the engine when jacking the vehicle. The wheels contacting the ground could cause the vehicle to move.

⚠ WARNING: Support the vehicle prior to performing any procedure requiring the vehicle to be jacked off the ground.

⚠ WARNING: Make sure the jack and jack stands are properly located to prevent the vehicle from falling.

⚠ WARNING: Wheel chocks should be used to prevent the vehicle from rolling and falling off the jack.

⚠ CAUTION: Never use a halfshaft as a lifting point.

Jacking Points — Front, 4x4

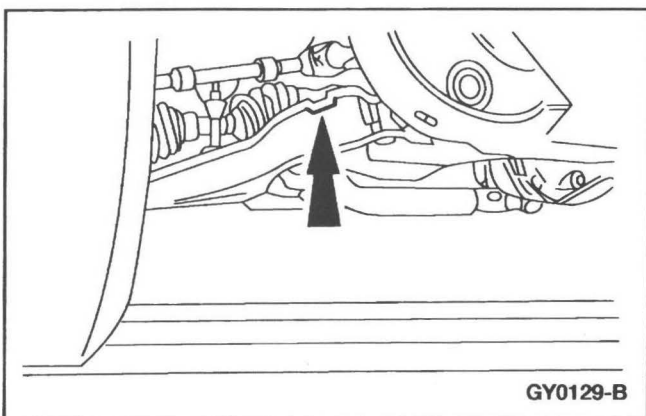

The jacking point is a raised boss located on the front suspension lower arm (3079).

Jacking Points — Front, 4x2

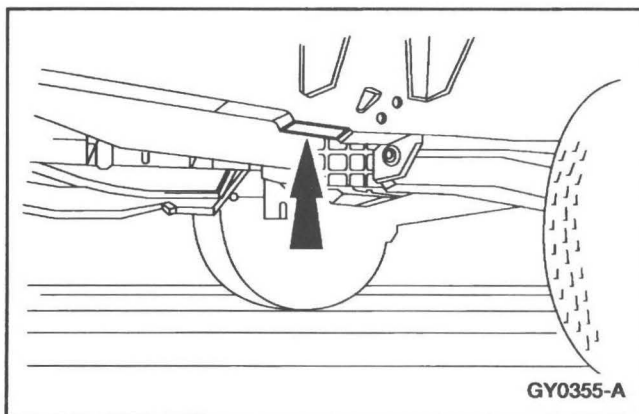

The jacking point is a flat portion on the frame indicated by the arrow cut out. The jacking point is located behind the front tire and wheel assembly.

Jacking Points — Rear

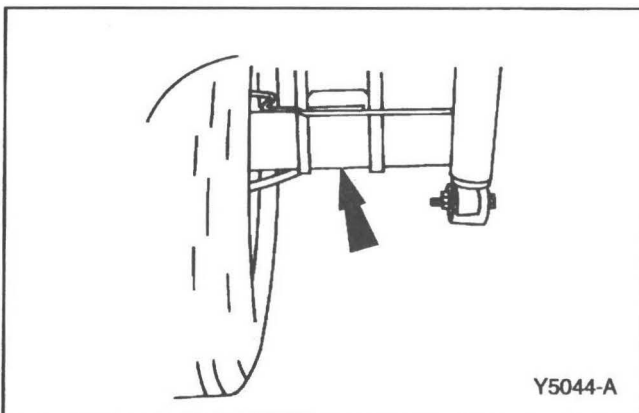

⚠ CAUTION: Never use the differential housing as a lifting point.

The rear jacking points are located on the rear axle (4001).



BUY IT NOW!

Click Here To Order



DESCRIPTION AND OPERATION (Continued)**Lifting**

⚠ WARNING: The electrical power to the air suspension system must be shut off prior to hoisting, jacking or towing an air suspension vehicle. This can be accomplished by turning off the air suspension switch located in the RH kick panel area. Failure to do so may result in unexpected inflation or deflation of the air spring which may result in shifting of the vehicle during these procedures.

⚠ CAUTION: Damage to suspension, exhaust and steering linkage components may occur if care is not exercised when positioning the hoist adapters prior to lifting the vehicle.

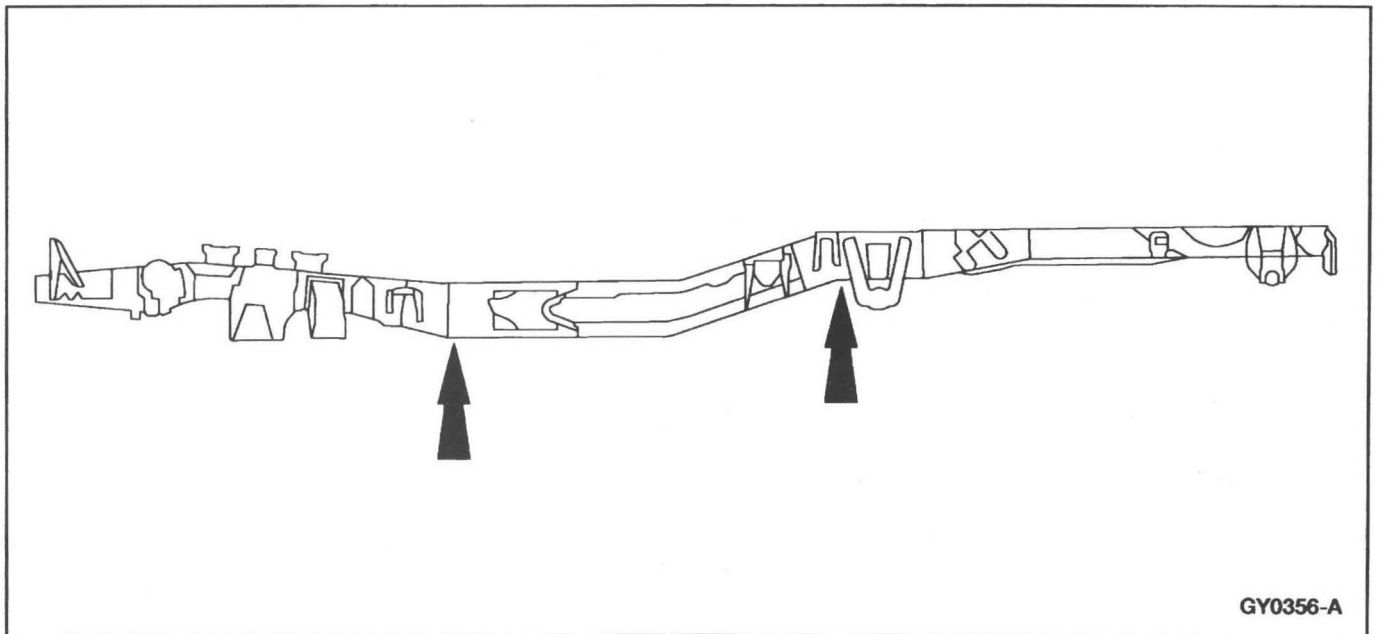
Lifting Points — Twin Post Hoist

Locate the front hoist adapters and rear hoist adapters (top of frame arc) as indicated.

**BUY IT NOW!****Click Here To Order** 

SECTION 100-04 Noise, Vibration and Harshness

CONTENTS	PAGE
DESCRIPTION AND OPERATION	
Noise, Vibration And Harshness (NVH)	100-04-2
Acceptable Noise, Vibration and Harshness	100-04-2
Diagnostic Theory	100-04-2
Glossary of Terms	100-04-2
Tools and Techniques	100-04-7
DIAGNOSIS AND TESTING	
Noise, Vibration And Harshness (NVH)	100-04-11
1: Customer Interview	100-04-15
2: Pre-Drive Check	100-04-15
3: Preparing for the Road Test	100-04-15
4: Verify the Customer Concern	100-04-15
5: Road Test	100-04-16
6: Check OASIS/TSBs/Repair History	100-04-18
7: Diagnostic Procedure	100-04-18
Component Tests	100-04-90
NVH Condition and Symptom Categories	100-04-19
Pinpoint Tests	100-04-57
Symptom Charts	100-04-20
GENERAL PROCEDURES	
Brake Disc Machining	100-04-95
Exhaust System Neutralizing	100-04-98
Powertrain/Drivetrain Mount Neutralizing	100-04-97
Wheel Bearing Check	100-04-99



BUY IT NOW!

Click Here To Order 



DESCRIPTION AND OPERATION

Noise, Vibration And Harshness (NVH)

Noise is any undesirable sound, usually unpleasant in nature. Vibration is any motion, shaking or trembling, that can be felt or seen when an object moves back and forth or up and down. Harshness is a ride quality issue where the vehicle's response to the road transmits sharply to the customer. Harshness normally describes a firmer than usual response from the suspension system. Noise, vibration and harshness (NVH) is a term used to describe these conditions, which result in varying degrees of dissatisfaction. Although, a certain level of NVH caused by road and environmental conditions is normal. This section is designed to aid in the diagnosis, testing and repair of NVH concerns.

Acceptable Noise, Vibration and Harshness

All internal combustion engines and drivelines produce some noise and vibration; operating in a real world environment adds noise that is not subject to control. Vibration isolators, mufflers and dampers reduce these to acceptable levels. A driver who is unfamiliar with a vehicle can think that some sounds are abnormal when actually the sounds are normal for the vehicle type. For example, Traction-Lok® differentials produce a slight noise on slow turns after extended highway driving. This is acceptable and has no detrimental effect on the locking axle function. As a technician, it is very important to be familiar with vehicle features and know how they relate to NVH concerns and their diagnosis. If, for example, the vehicle has automatic overdrive it is important to test drive the vehicle both in and out of overdrive mode.

Diagnostic Theory

The shortest route to an accurate diagnosis results from:

- system knowledge, including comparison with a known good system.
- system history, including repair history and usage patterns.
- condition history, especially any relationship to repairs or sudden change.
- knowledge of possible sources.
- using a systematic diagnostic method that divides the system into related areas.

The diagnosis and correction of noise, vibration and harshness concerns requires:

- a road or system test to determine the exact nature of the concern.
- an analysis of the possible causes.
- testing to verify the cause.
- repairing any concerns found.
- a road test or system test to make sure the concern has been corrected or brought back to within an acceptable range.

Glossary of Terms

Acceleration-Light

An increase in speed at less than half throttle.

Acceleration-Medium

An increase in speed at half to nearly full throttle, such as 0-97 km/h (0-60 mph) in approximately 30 seconds.

Acceleration-Heavy

An increase in speed at one-half to full throttle, such as 0-97 km/h (0-60 mph) in approximately 20 seconds.

Ambient Temperature

The surrounding or prevailing temperature.

Amplitude

The quantity or amount of energy produced by a vibrating component (G force). An extreme vibration has a high amplitude. A mild vibration has a low amplitude.

Backlash

Gear teeth clearance.

Boom

Low frequency or low pitched noise often accompanied by a vibration. Also refer to Drumming.

Bound Up

An overstressed isolation (rubber) mount that transmits vibration/noise instead of absorbing it.

Brakes Applied

When the service brakes are applied with enough force to hold the vehicle against movement with the transmission in gear.

100% SATISFACTION GUARANTEED

BUY IT NOW!

Click Here To Order

PayPal Discover MasterCard VISA

DESCRIPTION AND OPERATION (Continued)

Buffet/Buffering

Strong noise fluctuations (less than 1000 Hz) caused by gusting winds. An example would be wind gusts against the side glass.

Buzz

A low-pitched sound like (200-5000 Hz) that from a bee. Often a metallic or hard plastic humming sound. Also describes a high frequency (200-800 Hz) vibration. Vibration feels similar to an electric razor.

Camber

The angle of the wheel in relation to the true vertical as measured looking from the front of the vehicle. Camber is positive when the wheel angle is offset so that the top of the wheel is positioned away from the vehicle.

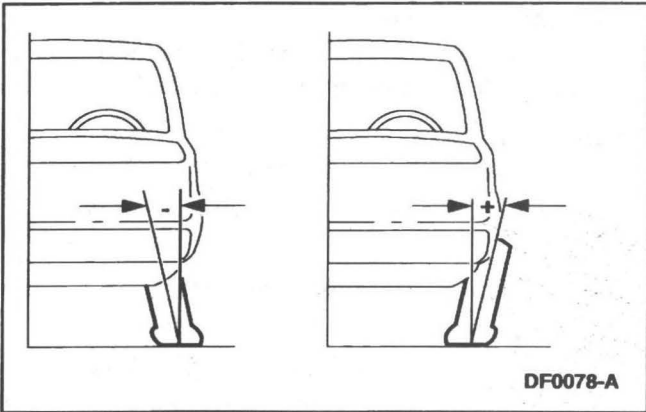

Caster

The angle of the steering knuckle in relation to the true vertical as measured looking from the side of the vehicle.

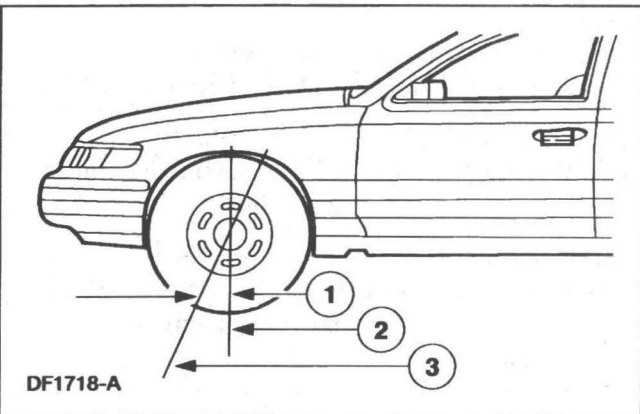

Chatter

A pronounced series of rapidly repeating rattling or clicking sounds.

Chirp

A short-duration high-pitched noise associated with a slipping drive belt.

Chuckle

A repetitious low-pitched sound. A loud chuckle is usually described as a knock.

Click

A sharp, brief, non-resonant sound, similar to actuating a ball point pen.

Clonk

A hydraulic knocking sound. Sound occurs with air pockets in a hydraulic system. Also described as hammering.

Clunk/Driveline Clunk

A heavy or dull, short-duration, low-frequency sound. Occurs mostly on a vehicle that is accelerating or decelerating abruptly. Also described as a thunk.

Coast/Deceleration

Releasing the accelerator pedal at cruise, allowing the engine to reduce vehicle speed without applying the brakes.

Coast/Neutral Coast

Placing the transmission range selector in NEUTRAL (N) or depressing the clutch pedal while at cruise.

Constant Velocity (CV) Joint

A joint used to absorb vibrations caused by driving power being transmitted at an angle.

Controlled Rear Suspension Height

The height at which a designated vehicle element must be when driveline angle measurements are made.

Coupling Shaft

The shaft between the transfer case and the front drive axle or, in a two-piece rear driveshaft, the front section.

CPS

Cycles per second. Same as hertz (Hz).

Cracks

A mid-frequency sound, related to squeak. Sound varies with temperature conditions.

Creak

A metallic squeak.

Item	Description
	Positive caster
	Negative vertical
	Steering axis



BUY IT NOW!

Click Here To Order



DESCRIPTION AND OPERATION (Continued)

Cruise

Constant speed on level ground; neither accelerating nor decelerating.

Cycle

The process of a vibrating component going through a complete range of motion and returning to the starting point.

Decibel

A unit of measurement, referring to sound pressure level, abbreviated dB.

Drive Engine Run-Up (DERU) Test

The operation of the engine through the normal rpm range with the vehicle standing still, the brakes applied and the transmission engaged. This test is used for noise and vibration checks.

Driveline Angles

The differences of alignment between the transmission output shaft, the driveshaft, and the rear axle pinion centerline.

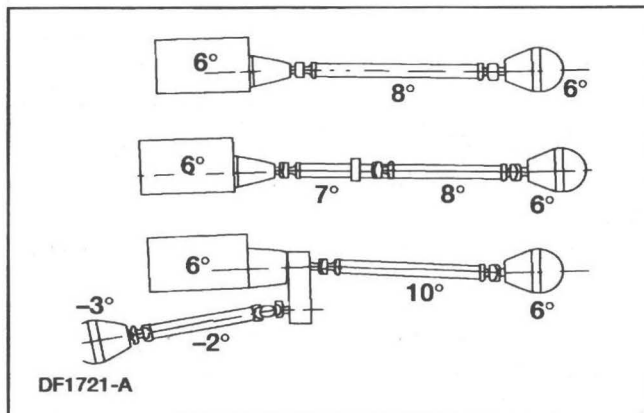

Driveshaft

The shaft that transmits power to the rear axle input shaft (pinion shaft). In a two-piece driveshaft, it is the rearmost shaft.

Drivetrain

All power transmitting components from the engine to the wheels; includes the clutch or torque converter, the transmission, the transfer case, the driveshaft, and the front or rear drive axle.

Drivetrain Damper

A weight attached to the engine, the transmission, the transfer case, or the axle. It is tuned by weight and placement to absorb vibration.

Drumming

A cycling, low-frequency (20-100 Hz), rhythmic noise often accompanied by a sensation of pressure on the ear drums. Also described as a low rumble, boom, or rolling thunder.

Dynamic Balance

The equal distribution of weight on each side of the centerline, so that when the wheel and tire assembly spins, there is no tendency for the assembly to move from side-to-side (wobble). Dynamically unbalanced wheel and tire assemblies can cause wheel shimmy.

Engine Imbalance

A condition in which an engine's center mass is not concentric to the rotation center, causing excessive motion.

Engine Misfire

When combustion in one or more cylinders does not occur or occurs at the wrong time.

Engine Shake

An exaggerated engine movement or vibration that directly increases in frequency as the engine speed increases. It is caused by non-equal distribution of mass in the rotating or reciprocating components.

Flexible Coupling

A flexible joint.

Float

A drive mode on the dividing line between cruise and coast where the throttle setting matches the engine speed with the road speed.

Flutter

Mid to high (100-2000 Hz) intermittent sound due to air flow. Similar to a flag flapping in the wind.

Frequency

The rate at which a cycle occurs within a given time.

Gravelly Feel

A grinding or growl in a component, similar to the feel experienced when driving on gravel.

Grind

An abrasive sound, similar to using a grinding wheel, or rubbing sand paper against wood.

Hiss

Steady high frequency (200-800 Hz) noise. Vacuum leak sound.

Hoot

A steady low frequency tone (50-500 Hz), sounds like blowing over a long neck bottle.



BUY IT NOW!

Click Here To Order

eady sound, like a
ed as a moan.



DESCRIPTION AND OPERATION (Continued)**Howl**

A mid-range frequency (200-800 Hz) noise between drumming and whine. Also described as a hum.

Hum

Mid-frequency (200-800 Hz) steady sound, like a small fan motor. Also described as a howl.

Hz

Hertz; a frequency measured in cycles per second.

Imbalance

Out of balance; heavier on one side than the other. In a rotating component, imbalance often causes vibration.

Inboard

Toward the centerline of the vehicle.

Intensity

The physical quality of sound that relates to the strength of the vibration (measured in decibels). The higher the sound's amplitude, the higher the intensity and vice versa.

Isolate

To separate the influence of one component to another.

Knock

A heavy, loud, repetitious sound, like a knock on the door.

Moan

A constant, low-frequency (100-200 Hz) tone. Also described as a hum.

Neutral Engine Run-Up (NERU) Test

The operation of the engine through the normal rpm range with the vehicle standing still and the transmission disengaged. This test is used to identify engine related vibrations.

Neutralize/Normalize

To return to an unstressed position. Used to describe mounts. Refer to Bound Up.

Outboard

Away from the centerline of the vehicle.

Ping

A short duration, high-frequency sound, which has a slight echo.

Pinion Shaft

The input shaft in a driving axle that is usually a part of the smaller driving or input hypoid gear of a ring and pinion gearset.

Pitch

The physical quality of sound that relates to its frequency. Pitch increases as frequency increases and vice versa.

Pumping Feel

A slow, pulsing movement.

Radial/Lateral

Radial is in the plane of rotation; lateral is at 90 degrees to the plane of rotation.

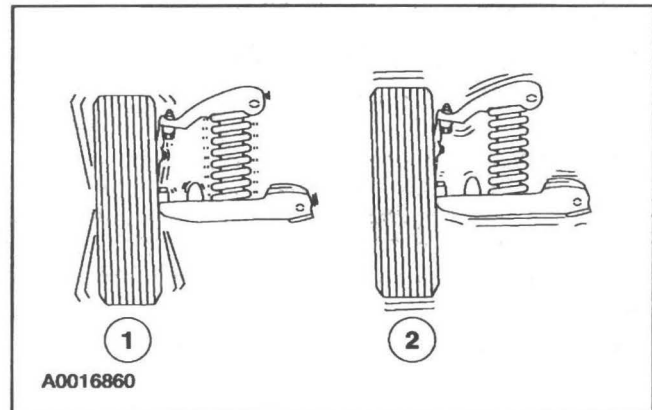

Item	Description
1	Lateral runout
2	Radial runout

Rattle

A random and momentary or short duration noise.

Ring Gear

The large, circular, driven gear in a ring and pinion gearset.

Road Test

The operation of the vehicle under conditions intended to produce the concern under investigation.

Roughness

A medium-frequency vibration. A slightly higher frequency (20 to 50 Hz) than a shake. This type of vibration is usually related to drivetrain components.

Runout

Lateral runout means measuring the movement or "wobble" of a wheel or tire at the sidewall. Radial runout means measuring the out-of-round at the tread surface.



BUY IT NOW!

Click Here To Order



DESCRIPTION AND OPERATION (Continued)**Rustling**

Intermittent sound of varying frequency (100-2000 Hz), sounds similar to shuffling through leaves.

Shake

A low-frequency vibration (5-20 Hz), usually with visible component movement. Usually relates to tires, wheels, brake drums or brake discs if it is vehicle speed sensitive, or engine if it is engine speed sensitive. Also referred to as a shimmy or wobble.

Shimmy

An abnormal vibration or wobbling, felt as a side-to-side motion of the steering wheel in the driveshaft rotation. Also described as waddle.

Shudder

A low-frequency vibration that is felt through the steering wheel or seat during light brake application.

Slap

A resonance from flat surfaces, such as safety belt webbing or door trim panels.

Slip Yoke/Slip Spline

The driveshaft coupling that allows length changes to occur while the suspension articulates and while the driveshaft rotates.

Squeak

A high-pitched transient sound, similar to rubbing fingers against a clean window.

Squeal

A long-duration, high-pitched noise.

Static Balance

The equal distribution of weight around the wheel. Statically unbalanced wheel and tire assemblies can cause a bouncing action called wheel tramp. This condition will eventually cause uneven tire wear.

Tap

A light, rhythmic, or intermittent hammering sound, similar to tapping a pencil on a table edge.

Thump

A dull beat caused by two items striking together.

Tick

A rhythmic tap, similar to a clock noise.

Tip-In Moan

A light moaning noise heard during light vehicle acceleration, usually between 40-100 km/h (25-65

TIR

The acronym for total indicated runout is TIR.

Tire Deflection

The change in tire diameter in the area where the tire contacts the ground.

Tire Flat Spots

A condition commonly caused by letting the vehicle stand while the tires cool off. This condition can be corrected by driving the vehicle until the tires are warm. Also, irregular tire wear patterns in the tire tread resulting from wheel-locked skids.

Tire Force Vibration

A tire vibration caused by variations in the construction of the tire that is noticeable when the tire rotates against the pavement. This condition can be present on perfectly round tires because of variations in the inner tire construction. This condition can occur at wheel rotation frequency or twice rotation frequency.

Transient

A noise or vibration that is momentary, a short duration.

Two-Plane Balance

Radial and lateral balance.

Vibration

Any motion, shaking or trembling, that can be felt or seen when an object moves back and forth or up and down.

Whine

A constant, high-pitched noise. Also described as a screech.

Whistle

High-pitched noise (above 500 Hz) with a very narrow frequency band. Examples of whistle noises are a turbocharger or airflow around an antenna.

Wind Noise

Any noise caused by air movement in, out or around the vehicle.

WOT

The acronym for wide open throttle is WOT.

**SATISFACTORY
100%
GUARANTEED**

BUY IT NOW!

Click Here To Order

PayPal American Express Discover MasterCard VISA

DESCRIPTION AND OPERATION (Continued)

Tools and Techniques

Electronic Vibration Analyzer (EVA)

The EVA is a hand-held electronic diagnostic tool which will assist in locating the source of unacceptable vibrations. The vibration sensor can be remotely mounted anywhere in the vehicle for testing purposes. The unit displays the three most common vibration frequencies and their corresponding amplitudes simultaneously. A bar graph provides a visual reference of the relative signal strength (amplitude) of each vibration being displayed and its relative G force. The keypad is arranged to make the EVA simple to program and use. Some of the functions include the ability to average readings as well as record, play back and freeze readings. The EVA has a strobe balancing function that can be used to detect imbalance on rotating components such as a driveshaft or engine accessories.

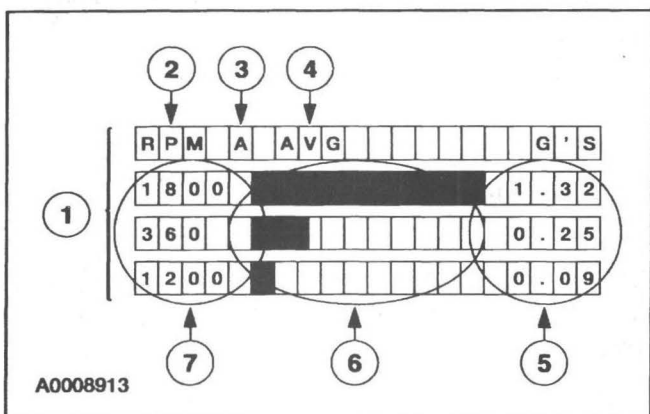

Item	Description
1	EVA screen
2	Frequency mode displayed in rpm or Hz
3	Active sensor input (A or B)
4	Current active mode
5	G force indicators or the strongest frequencies in descending strength of each vibration

(Continued)

Item	Description
6	Strength of each vibration
7	Frequency in rpm/Hz of each vibration

The EVA allows for a systematic collection of information that is necessary to accurately diagnose and repair NVH problems. For the best results, carry out the test as follows:

- Test drive the vehicle with the vibration sensor inside the vehicle.
- Place the sensor in the vehicle according to feel.
 - If the condition is felt through the steering wheel, the source is most likely in the front of the vehicle.
 - A vibration that is felt in the seat or floor only will most likely be found in the driveline, drive axle or rear wheels and tires.
- Record the readings. Also note when the condition begins, when it reaches maximum intensity, and if it tends to diminish above/below a certain speed.
 - Frequencies should be read in the “average” mode.
 - Frequencies have a range of plus or minus 2. A reading of 10 Hz can be displayed as an 8 Hz through 12 Hz.
- Determine what the normal frequency is for the vehicle at a specified speed. Multiply the rear axle ratio by the Hz (1 Hz per every 5 mph). Example: A vehicle travelling 50 mph with a 3.08 rear axle ratio, the acceptable amount of Hz for the vehicle at that speed would be $10 (1 \text{ Hz per every } 5 \text{ mph}) \times 3.08 (\text{rear axle ratio}) = 30.8 \text{ Hz}$.
- Place the vibration sensor on or near the suspect area outside the vehicle.
- Continue the road test, driving the vehicle at the speed the symptom occurs, and take another reading.

100% SATISFACTION GUARANTEED

BUY IT NOW!

Click Here To Order

DESCRIPTION AND OPERATION (Continued)

- g. Compare the readings.
 - A match in frequency indicates the problem component or area.
 - An unmatched test could indicate the concern is caused by the engine, torque converter, or engine accessory. Use the EVA in the rpm mode and check if concern is rpm related.
 - Example: A vibration is felt in the seat. Place the sensor on the console. Record the readings. Place the vibration sensor on the rear axle. Compare the readings. If the frequencies are the same, the axle is the problem component. Also refer to the following chart as a reference to acceptable vibration and noise ranges for the specified components.

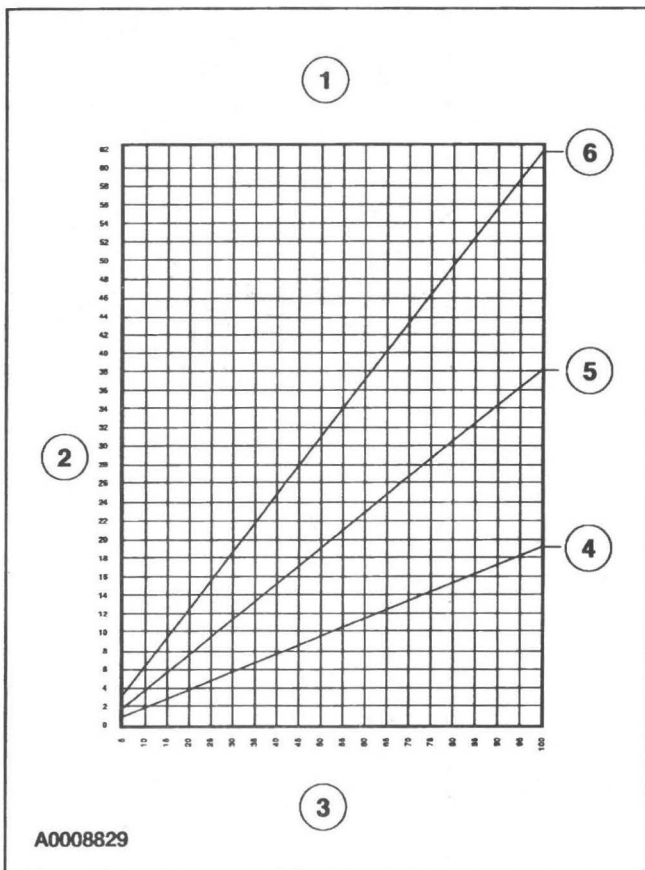

Item	Description
1	Acceptable vibration ranges for specified components
2	Hertz (Hz)

(Continued)

Item	Description
3	Miles per hour (mph)
4	First order tire (one disturbance for each revolution)
5	Second order tire (two disturbances for each revolution)
6	Driveline

Vibrate Software®

Vibrate Software® (Rotunda tool number 215-00003) is a diagnostic aid which will assist in pinpointing the source of unacceptable vibrations. The engine's crankshaft is the point of reference for vibration diagnosis. Every rotating component will have an angular velocity that is faster, slower, or the same as the engine's crankshaft. Vibrate Software® calculates the angular velocity of each component and graphically represents these velocities on a computer screen and on a printed vibration worksheet. The following steps outline how Vibrate Software® helps diagnose a vibration concern:

- Enter the vehicle information. Vibrate will do all the calculations and display a graph showing tire, driveshaft and engine vibrations.
- Print a Vibration Worksheet graph. The printed graph is to be used during the road test.
- Road test the vehicle at the speed where the vibration is most noticeable. Record the vibration frequency (rpm) and the engine rpm on the worksheet graph. The point on the graph where the vibration frequency (rpm) reading and the engine rpm reading intersect indicates the specific component group causing the concern.
 - An EVA or equivalent tool capable of measuring vibration frequency and engine rpm will be needed.
- Provide pictures of diagnostic procedures to aid in testing components.

Combination EngineEAR/ChassisEAR

An electronic listening device used to quickly identify noise and the location under the chassis while the vehicle is being road tested. The ChassisEARs can identify the noise and location of damaged/worn wheel bearings, CV joints, brakes, springs, axle bearings or driveshaft carrier bearings.



BUY IT NOW!

Click Here To Order



DESCRIPTION AND OPERATION (Continued)

EngineEAR Basic Unit

An electronic listening device used to detect even the faintest noises. The EngineEARs can detect the noise of damaged/worn bearings in generators, water pumps, A/C compressors and power steering pumps. They are also used to identify noisy lifters, exhaust manifold leaks, chipped gear teeth and for detecting wind noise. The EngineEAR has a sensing tip, amplifier, and headphones. The directional sensing tip is used to listen to the various components. Point the sensing tip at the suspect component and adjust the volume with the amplifier. Placing the tip in direct contact with a component will reveal structure-borne noise and vibrations, generated by or passing through, the component. Various volume levels can reveal different sounds.

Ultrasonic Leak Detector

The Ultrasonic Leak Detector is used to detect wind noises caused by leaks and gaps in areas where there is weather-stripping or other sealing material. It is also used to identify A/C leaks, vacuum leaks and evaporative emission noises. The Ultrasonic Leak Detector includes a multi-directional transmitter (operating in the ultrasonic range) and a hand-held detector. The transmitter is placed inside the vehicle. On the outside of the vehicle, the hand-held detector is used to sweep the area of the suspected leak. As the source of the leak is approached, a beeping sound is produced which increases in both speed and frequency.

Squeak and Rattle Repair Kit

The squeak and rattle repair kit (Rotunda tool number 164-R4900) contains lubricants and self-adhesive materials that can be used to eliminate interior and exterior squeaks and rattles. The kit consists of the following materials:

- PVC (soft foam) tape
- Urethane (hard foam) tape

- Flocked (black fuzzy) tape
- UHMW (frosted) tape
- Squeak and rattle oil tube
- Squeak and rattle grease tube

Tracing Powder

Tracing powder is used to check both the uniformity of contact and the tension of a seal against its sealing surface. These tests are usually done when a suspected air leak/noise appears to originate from the seal area or during the alignment and adjustment of a component to a weatherstrip. Tracing powder can be ordered from Crest Industries as ATR Leak Trace. Carry out the tracing powder test as follows:

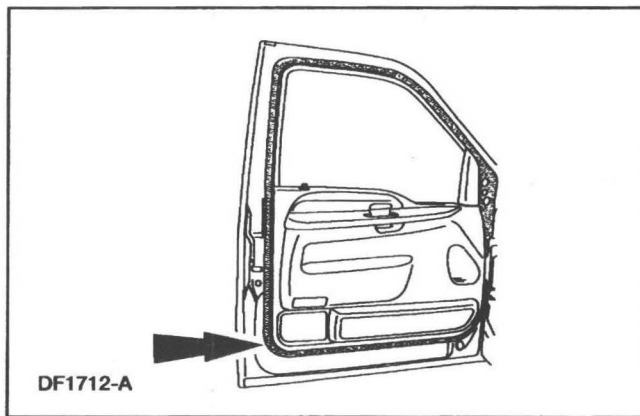

- a. Clean the weatherstrip.
- b. Spray the tracing powder on the mating surface only.
- c. Close the door completely. Do not slam the door.



BUY IT NOW!

Click Here To Order



DESCRIPTION AND OPERATION (Continued)

- d. Open the door. An imprint is made where the weatherstrip contacted the mating surface seal. Gaps or a faint imprint will show where there is poor contact with the weatherstrip.

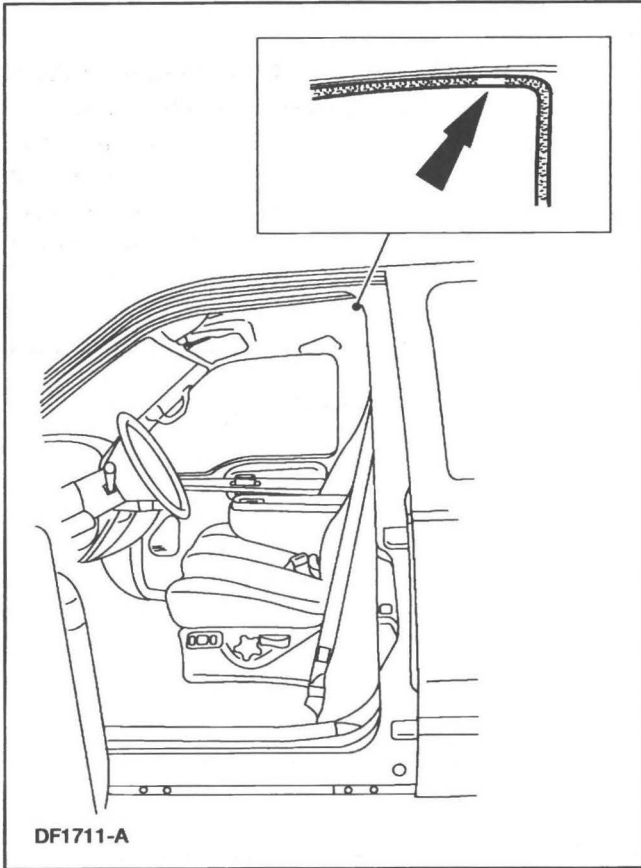

Index Card

Place an index card or a piece of paper between the weatherstrip and the sealing surface, then close the door. Slowly withdraw the index card or paper after the door is closed and check the amount of pressure on the weatherstrip. There should be a medium amount of resistance as it is withdrawn. Continue around the entire seal area. If there is little or no resistance, this indicates insufficient contact to form a good seal. At these points, the door, the glass, or the weatherstrip is out of alignment.

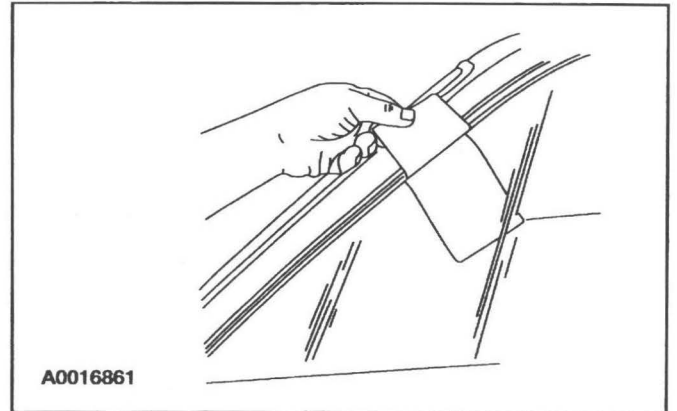

SATISFACTION 100% GUARANTEED

BUY IT NOW!



Click Here To Order

PayPal American Express Discover MasterCard VISA

DIAGNOSIS AND TESTING

Noise, Vibration And Harshness (NVH)

Special Tool(s)

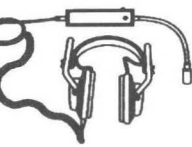
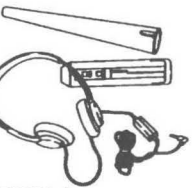
 <p>ST2048-A</p>	<p>ChassisEAR 107-R2102 or equivalent</p>
 <p>ST2311-A</p>	<p>Electronic Vibration Analyzer 100-F027 (014-00344) or equivalent</p>
 <p>ST2312-A</p>	<p>EngineEAR 107-R2100 or equivalent</p>
 <p>ST2314-A</p>	<p>Ultrasonic Leak Detector 134-R0135 or equivalent</p>

To assist the service advisor and the technician, a Write-up Job Aid and an NVH Diagnostic Guide are included with this material. The Write-up Job Aid serves as a place to record all important symptom information. The NVH Diagnostic Guide serves as a place to record information reported on the Write-up Job Aid as well as data from the testing to be carried out.

100% SATISFACTION GUARANTEED

BUY IT NOW!

Click Here To Order 







DIAGNOSIS AND TESTING (Continued)

To begin a successful diagnosis, fill out the NVH Diagnostic Guide, record the reported findings, then proceed to each of the numbered process steps to complete the diagnosis.



"WRITE-UP" JOB AID

REPAIR ORDER # _____
 CUSTOMER CONCERN # _____

SPECIFIC SENSE IDENTIFICATION AND LOCATION ON VEHICLE OF CUSTOMER SYMPTOM(S)

INSTRUCTIONS: Check below sense affected and location of concern on the generic vehicle illustration (darken the vehicle area). Plus circle appropriate responses to the right.

NOTE: Shaded backgrounds indicate caution areas. Selection of two or more caution areas "flag" difficult repairs. In general, shaded areas are the more difficult to verify and repair, and require all applicable columns to be completed.



SEE
YES



FEEL
YES



HEAR
YES



SMELL
YES

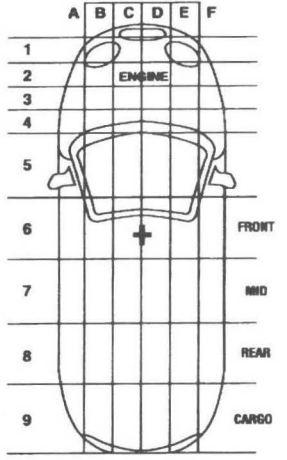

VEHICLE SYMPTOM AREA	HOW OFTEN?	VEHICLE OPERATING MODE	VEHICLE CONDITIONS	VEHICLE SPEED (mph)	WHEN VEHICLE IS*	AMBIENT CONDITION
Front of Vehicle	Always	Start Up	Accessories On (define below)	0	Turning Left	° Below Zero
Engine Compartment	Daily (A.M., P.M.)	Idle		1-9	Turning Right	Below Freezing (0°-19°)
Dash	Conditional	Gear Selection	Windows Open	10-19	Over Bumps	Below Freezing (20°-32°)
Steering Wheel	Weekly	Accel Light	4x4	20-29	Up Hills	33°-49°
Accelerator Pedal	Monthly	Accel Moderate	Hauling	30-39	Down Hills	50°-69°
Brake Pedal	Intermittent	Accel Heavy	Towing	40-49	Shifting	70°-89°
Clutch Pedal	Unknown	Steady Speed	Snow Plowing	50-59	Parked	90°+
Seat		Deceleration	Other (define below)	60-69	In Traffic	Sunny
Rear of Vehicle		Neutral		70+		Dry
Top of Vehicle		Reverse		ENGINE TEMP		Windy
Floor Pan		Stopping/Braking				Wet/Humid
Under Vehicle				Cold		Rain
Other (define below)				Normal		Snow
				Hot		Ice

DEALER VERIFICATION

	YES	NO
SERVICE ADVISOR	<input type="checkbox"/>	<input type="checkbox"/>
SHOP FOREMAN	<input type="checkbox"/>	<input type="checkbox"/>
SERVICE MANAGER	<input type="checkbox"/>	<input type="checkbox"/>
QC MANAGER	<input type="checkbox"/>	<input type="checkbox"/>
TECHNICIAN	<input type="checkbox"/>	<input type="checkbox"/>
VERIFIED WITH CUSTOMER	<input type="checkbox"/>	<input type="checkbox"/>

WHAT THE CUSTOMER SAID

OASIS SYMPTOM CODE(S)
VIN NUMBER

<table border="1" style="width: 100%; height: 20px; border-collapse: collapse;"> <tr><td style="width: 12.5%;"></td><td style="width: 12.5%;"></td><td style="width: 12.5%;"></td><td style="width: 12.5%;"></td><td style="width: 12.5%;"></td><td style="width: 12.5%;"></td><td style="width: 12.5%;"></td><td style="width: 12.5%;"></td></tr> <tr><td style="width: 12.5%;"></td><td style="width: 12.5%;"></td><td style="width: 12.5%;"></td><td style="width: 12.5%;"></td><td style="width: 12.5%;"></td><td style="width: 12.5%;"></td><td style="width: 12.5%;"></td><td style="width: 12.5%;"></td></tr> </table>																	<table border="1" style="width: 100%; height: 20px; border-collapse: collapse;"> <tr><td style="width: 12.5%;"></td><td style="width: 12.5%;"></td><td style="width: 12.5%;"></td><td style="width: 12.5%;"></td><td style="width: 12.5%;"></td><td style="width: 12.5%;"></td><td style="width: 12.5%;"></td><td style="width: 12.5%;"></td><td style="width: 12.5%;"></td><td style="width: 12.5%;"></td><td style="width: 12.5%;"></td><td style="width: 12.5%;"></td><td style="width: 12.5%;"></td><td style="width: 12.5%;"></td><td style="width: 12.5%;"></td><td style="width: 12.5%;"></td><td style="width: 12.5%;"></td><td style="width: 12.5%;"></td><td style="width: 12.5%;"></td></tr> </table>																			

A0017007

BUY IT NOW!

Click Here To Order





DIAGNOSIS AND TESTING (Continued)

NVH DIAGNOSTIC GUIDE

Dealer: _____ Date: _____

P.A. Code: _____ Order No. _____ Technician: _____

Owner's Name: _____ Address: _____

Phone No. Home: _____ Work: _____

Vehicle Make: _____ Model: _____ Year: _____

VIN: _____ Mileage: _____ Engine: _____ Trans: _____ Axle: _____

OWNER'S DESCRIPTION OF COMPLAINT:

Did Condition Exist When Vehicle Was New? Yes / No (circle one)

How Did Condition Begin? Gradually Suddenly

At What Mileage Did It Occur Or Begin Occuring? _____

Which Driving Conditions Affect The Vehicle?

- Light Accel Medium Accel Heavy Accel Closed Throttle Decel Coast (Float) Constant Speed Brakes Applied/Released Driving The Vehicle: Straight Cornering

Is Vibration Noticed? If So, Where:

- Seat Steering Wheel Instrument Panel Floor Body Panels Ft/Rr of Vehicle

Is There Sound Or Sensation Of Sound? Yes / No (circle one)

If So, Describe The Sound :

- Boom Hum Whine Growl Other: _____ Drone Tip-In-Moan Squeak Rattle

PREDRIVE CHECKS

Tire Condition/Pressure: _____

Vehicle Body Damage? _____

Other: _____

ROAD TEST:

Vibration/Noise Occurs:

Vehicle Speed _____ Accel _____ Vibration Frequency _____ Hz/RPM Gear Range _____ Decel/Coast _____ Engine Speed _____ RPM

ENGINE RUN-UP TESTS

Neutral Engine Run-Up (NERU) Yes / No Engine RPM _____ Vibration/Frequency _____ Hz/RPM

Drive Engine Run-Up (DERU) Yes / No Engine RPM _____ Vibration/Frequency _____ Hz/RPM

Drivetrain Run-Up (DTRU) Yes / No Engine RPM _____ Vibration/Frequency _____ Hz/RPM

Indicate Suspected Area of Concern:

- Tire/Wheel/Brakes Engine/Accessory Rear Driveline/Axle Susp/Steering Right Body Front Left

Other _____

Equipment Used:

- Reed Tachometer Electronic Noise Detector Tape Engine Tachometer Ultrasonic Leak Detector Other _____



BUY IT NOW!

Click Here To Order



DIAGNOSIS AND TESTING (Continued)

WHEEL/TIRE/BRAKES CHECK:

Balance Check Yes / No

Maximum Runout Allowed:

Wheel: Radial _____ Lateral _____

Tire: Radial _____ Lateral _____

Measured Runout:

Tire/Wheel Radial: LF _____ LR _____ RF _____ RR _____

Lateral: LF _____ LR _____ RF _____ RR _____

Wheel Only Radial: LF _____ LR _____ RF _____ RR _____

Lateral: LF _____ LR _____ RF _____ RR _____

SUSPENSION INSPECTION:

Can Cause: Shimmy Clunk Squeak Harshness

Suspension Bushings: Loose Worn Missing OK

Front Upper Control Arm Stabilizer (sway bar) Rear Lower Control Arm

Front Lower Control Arm Rear Upper Control Arm Rear Upper Control Arm

Other _____

Suspension/Steering Components: Loose Worn Missing OK

Ball Joints Idler Arm Pitman Arm

Shock Absorbers F/R Center Link Steering Gear

Springs F/R Tie Rod Ends/Sleeve Steering Coupler

DRIVESHAFT CONDITION: Noise Vibration

Balance Weights Missing/Other Visual Defects? Yes / No

Maximum Allowable Runout: _____

Actual Runout: Front _____ Middle _____ Rear _____

Two-Piece Driveshaft Runout: Front _____ Rear _____

Middle Support Bearing: Loose Damaged Worn Other _____

Suspect Driveshaft Balanced? Yes / No

Pinion Angle: Engine Height: Specification _____ Actual _____

Pinion Angle: Specification _____ Actual _____

Driveline Angle - Truck: Specification _____ Actual _____

ENGINE/ACCESSORY CHECK:

Visual Inspection for Damage or Grounded Condition:

Powertrain Mounts Fuel Lines A/C Lines Power Steering/Cooler Lines

Air Intake Accessories Exhaust Radiator/Condensor

BODY (NOISE/RATTLE)

Indicate Suspected Area of Concern: Doors Windows Dash Panel Other _____

Tests Used to Isolate

NVH Concern: Vacuum/Leak Detector Ultrasonic Leak Detector Tracing Powder

Electronic Noise Detector Other _____

ROAD/ENGINE RUN-UP TESTS: Improved? Yes / No Vehicle Acceptable? Yes / No

Comments: _____

A0008914

100% SATISFACTION GUARANTEED BUY IT NOW! Click Here To Order



DIAGNOSIS AND TESTING (Continued)

1: Customer Interview

The diagnostic process starts with the customer interview. The service advisor must obtain as much information as possible about the problem and take a test drive with the customer. There are many ways a customer will describe NVH concerns and this will help minimize confusion arising from descriptive language differences. It is important that the concern is correctly interpreted and the customer descriptions are recorded. During the interview, ask the following questions:

- When was it first noticed?
- Did it appear suddenly or gradually?
- Did any abnormal occurrence coincide with or precede its appearance?

Use the information gained from the customer to accurately begin the diagnostic process.

2: Pre-Drive Check

It is important to do a pre-drive check before road testing the vehicle. A pre-drive check verifies that the vehicle is relatively safe to drive and eliminates any obvious faults on the vehicle.

The pre-drive check consists of a brief visual inspection. During this brief inspection, take note of anything that will compromise safety during the road test and make those repairs/adjustments before taking the vehicle on the road.

3: Preparing for the Road Test

Observe the following when preparing for the road test:

- Review the information recorded on the NVH Diagnostic Guide. It is important to know the specific concern the customer has with the vehicle.
- Do not be misled by the reported location of the noise/vibration. The cause can actually be some distance away.

- Remember that the vibrating source component (originator) may only generate a small vibration. This small vibration can in turn cause a larger vibration/noise to emanate from another receiving component (reactor), due to contact with other components (transfer path).
- Conduct the road test on a quiet street where it is safe to duplicate the vibration/noise. The ideal testing route is an open, low-traffic area where it is possible to operate the vehicle at the speed in which the condition occurs.
- If possible, lower the radio antenna in order to minimize turbulence. Identify anything that could potentially make noise or be a source of wind noise. Inspect the vehicle for add-on items that create vibration/noise. Turn off the radio and the heating and cooling system blower.
- The engine speed is an important factor in arriving at a final conclusion. Therefore, connect an accurate tachometer to the engine, even if the vehicle has a tachometer. Use a tachometer that has clearly defined increments of less than 50 rpm. This ensures an exact engine speed reading.

4: Verify the Customer Concern

Verify the customer concern by carrying out a road test, an engine run-up test, or both.

The decision to carry out a road test, an engine run-up test, or both depends on the type of NVH concern. A road test may be necessary if the symptom relates to the suspension system or is sensitive to torque. A drive engine run-up (DERU) or a neutral engine run-up (NERU) test identifies noises and vibrations relating to engine and drivetrain rpm. Remember, a condition will not always be identifiable by carrying out these tests, however, they will eliminate many possibilities if carried out correctly.

SATISFACTION 100% GUARANTEED

BUY IT NOW!

Click Here To Order

PayPal American Express Discover MasterCard VISA

DIAGNOSIS AND TESTING (Continued)

5: Road Test

NOTE: It may be necessary to have the customer ride along or drive the vehicle to point out the concern. During the road test, take into consideration the customer's driving habits and the driving conditions. The customer's concern just may be an acceptable operating condition for that vehicle.

The following is a brief overview of each test in the order in which it appears. A review of this information helps to quickly identify the most appropriate process necessary to make a successful diagnosis. After reviewing this information, select and carry out the appropriate test(s), proceeding to the next step of this process.

- The Slow Acceleration Test is normally the first test to carry out when identifying an NVH concern, especially when a road test with the customer is not possible.
- The Heavy Acceleration Test helps to determine if the concern is torque-related.
- The Neutral Coast Down Speed Test helps to determine if the concern is vehicle speed-related.
- The Downshift Speed Test helps to determine if the concern is engine speed-related.
- The Steering Input Test helps to determine how the wheel bearings and other suspension components contribute to a vehicle speed-related concern.
- The Brake Test helps to identify vibrations or noise that are brake related.
- The Road Test Over Bumps helps isolate a noise that occurs when driving over a rough or bumpy surface.
- The Engine Run-Up Tests consist of the Neutral Run-Up Test and the Engine Load Test. These tests help to determine if the concern is engine speed-related.
- The Neutral Run-Up Test is used as a follow-up test to the Downshift Speed Test when the concern occurs at idle.
- The Engine Load Test helps to identify vibration/noise sensitive to engine load or torque. It also helps to reproduce engine speed-related concerns that cannot be duplicated when carrying out the Neutral Run-Up Test or the Neutral Coast Down Test.

- The Vehicle Cold Soak Procedure helps to identify concerns occurring during initial start-up and when an extended time lapse occurs between vehicle usage.

Slow Acceleration Test

To carry out this test, proceed as follows:

- Slowly accelerate to the speed where the reported concern occurs. Note the vehicle speed, the engine rpm and, if possible, determine the vibration frequency.
- Attempt to identify from what part of the vehicle the concern is coming.
- Attempt to identify the source of the concern.
- Proceed as necessary.

Heavy Acceleration Test

To carry out this test, proceed as follows:

- Accelerate hard from 0-64 km/h (0-40 mph).
- Decelerate in a lower gear.
- The concern is torque related if duplicated while carrying out this test.
- Proceed as necessary.

Neutral Coast Down Speed Test

To carry out this test, proceed as follows:

- Drive at a higher rate of speed than where the concern occurred when carrying out the Slow Acceleration Test.
- Place the transmission in NEUTRAL and coast down past the speed where the concern occurs.
- The concern is vehicle speed-related if duplicated while carrying out this test. This eliminates the engine and the torque converter as sources.
- If the concern was not duplicated while carrying out this test, carry out the Downshift Speed Test to verify if the concern is engine speed related.
- Proceed as necessary.

Downshift Speed Test

To carry out this test, proceed as follows:

- Shift into a lower gear than the gear used when carrying out the Slow Acceleration Test.
- Drive at the engine rpm where the concern occurs.



BUY IT NOW!

Click Here To Order

to locate faulty engine speed-related



DIAGNOSIS AND TESTING (Continued)

- The concern is engine speed related if duplicated while carrying out this test. This eliminates the tires, wheels, brakes and the suspension components as sources.
- If necessary, repeat this test using other gears and NEUTRAL to verify the results.
- Proceed as necessary.

Steering Input Test

To carry out this test, proceed as follows:

- Drive at the speed where the concern occurs, while making sweeping turns in both directions.
- If the concern goes away or gets worse, the wheel bearings, hubs, U-joints (contained in the axles of 4WD applications), and tire tread wear are all possible sources.
- Proceed as necessary.

Brake Test

To carry out this test, proceed as follows:

- Warm the brakes by slowing the vehicle a few times from 80-32 km/h (50-20 mph) using light braking applications. At highway speeds of 89-97 km/h (50-60 mph), apply the brake using a light pedal force.
- Accelerate to 89-97 km/h (55-60 mph).
- Lightly apply the brakes and slow the vehicle to 30 km/h (20 mph).
- A brake vibration noise can be felt in the steering wheel, seat or brake pedal. A brake noise can be heard upon brake application and diminish when the brake is released.

Road Test Over Bumps

To carry out this test, proceed as follows:

- Drive the vehicle over a bump or rough surface one wheel at a time to determine if the noise is coming from the front or the back and the left or the right side of the vehicle.
- Proceed as necessary.

Neutral Engine Run-Up (NERU) Test

To carry out this test, proceed as follows:

- Install a tachometer.
- Increase the engine rpm up from an idle to approximately 4000 rpm while in PARK on front wheel drive vehicles with automatic transmissions, or NEUTRAL for all other vehicles. Note the engine rpm and, if possible, determine the vibration frequency.
- Attempt to identify what part of the vehicle the concern is coming from.
- Attempt to identify the source of the concern.
- Proceed as necessary.

Drive Engine Run-Up (DERU) Load Test

To carry out this test, proceed as follows:

-  **WARNING: Block the front and rear wheels, and apply the parking brake and the service brake, or injury to personnel can result.**

 **CAUTION: Do not carry out the Engine Load Test for more than five seconds or damage to the transmission or transaxle can result.**
Block the front and rear wheels.

- Apply the parking brake and the service brake.
- Install a tachometer.
- Shift the transmission into DRIVE, and increase and decrease the engine rpm between an idle to approximately 2000 rpm. Note the engine rpm and, if possible, determine the vibration frequency.
- Repeat the test in REVERSE.
- If the vibration/noise is duplicated when carrying out this test, inspect the engine and transmission or transaxle mounts.
- If the concern is definitely engine speed-related, carry out the Engine Accessory Test to narrow down the source.
- Proceed as necessary.



100% SATISFACTION GUARANTEED

BUY IT NOW!

Click Here To Order

PayPal American Express Discover MasterCard VISA

DIAGNOSIS AND TESTING (Continued)

Engine Accessory Test

To carry out this test, proceed as follows:

- **⚠ WARNING: Block the front and rear wheels, and apply the parking brake and the service brake, or injury to personnel can result.**
- **⚠ CAUTION: Limit engine running time to one minute or less with belts removed or serious engine damage will result.**

NOTE: A serpentine drive belt decreases the usefulness of this test. In these cases, use an electronic vibration analyzer, such as the electronic vibration analyzer (EVA), to pinpoint accessory vibrations. An electronic listening device, such as an EngineEAR, will also help to identify noises from specific accessories.

Remove the accessory drive belts.

- Increase the engine rpm to where the concern occurs.
- If the vibration/noise is duplicated when carrying out this test, the belts and accessories are not sources.
- If the vibration/noise was not duplicated when carrying out this test, install each accessory belt, one at a time, to locate the source.

Vehicle Cold Soak Procedure

To carry out this procedure, proceed as follows:

- Test preparations include matching customer conditions (if known). If not known, document the test conditions: gear selection and engine rpm. Monitor the vibration/noise duration with a watch for up to three minutes.
- Park the vehicle where testing will occur. The vehicle must remain at or below the concern temperature (if known) for 6-8 hours.
- Before starting the engine, conduct a visual inspection under the hood.
- Turn the key on, but do not start the engine. Listen for the fuel pump, anti-lock brake system (ABS) and air suspension system noises.
- Start the engine.

- **⚠ CAUTION: Never probe moving parts.**
Isolate the vibration/noise by carefully listening. Move around the vehicle while listening to find the general location of the vibration/noise. Then, search for a more precise location by using a stethoscope or EngineEAR.
- Refer to Idle Noise/Vibration in the Symptom Chart to assist with the diagnosis.

6: Check OASIS/TSBs/Repair History

After verifying the customer concern, check for OASIS reports, TSBs and the vehicle repair history for related concerns. If information relating to a diagnosis/repair is found, carry out the procedure(s) specified in that information.

If no information is available from these sources, carry out the vehicle preliminary inspection to eliminate any obvious faults.

7: Diagnostic Procedure

Qualifying the concern by the particular sensation present can help narrow down the concern. Always use the “symptom” to “system” to “component” to “cause” diagnosis technique. This diagnostic method divides the problem into related areas to correct the customer concern.

- Verify the “symptom”.
- Determine which “system(s)” can cause the “symptom”.
 - If a vibration concern is vehicle speed related, the tire and wheel rpm/frequency or driveshaft frequency should be calculated.
 - If a vibration concern is engine speed related, the engine, engine accessory or engine firing frequencies should be calculated.
- After determining the “system”, use the diagnostic tools to identify the worn or damaged “components”.
- After identifying the “components”, try to find the “cause” of the failure.

100% SATISFACTION GUARANTEED

BUY IT NOW!

Click Here To Order

PayPal American Express Cards Discover MasterCard VISA

DIAGNOSIS AND TESTING (Continued)

Once the concern is narrowed down to a symptom/condition, proceed to NVH Condition and Symptom Categories.

NVH Condition and Symptom Categories

A good diagnostic process is a logical sequence of steps that lead to the identification of a causal system. Use the condition and symptom categories as follows:

- Identify the operating condition that the vehicle is exhibiting.
- Match the operating condition to the symptom.
- Verify the symptom.
- Identify which category or system could cause the symptom.
- Refer to the diagnostic symptom chart that is referred to.

Operating Condition—Vehicle is Not Moving

1. Static operation

- Noise occurs during component/system functioning. GO to **Symptom Chart — Squeak and Rattle**.

2. While cranking

- 1 Grinding or whine, differential ring gear or starter motor pinion noise. GO to **Symptom Chart — Engine Noise/Vibration**.
- 2 Rattle. Exhaust hanger, exhaust heat shield or A/C line noise. GO to **Symptom Chart — Squeak and Rattle**.
- 3 Vibration. Acceptable condition.

3. At idle

- Idle noise. GO to **Symptom Chart — Idle Noise/Vibration**.
- Idle vibration or shake. GO to **Symptom Chart — Idle Noise/Vibration**.

4. During Gear Selection

- 1 Vehicle parked on a steep incline. Acceptable noise.
- 2 Vehicle parked on a flat surface. GO to **Symptom Chart — Driveline Noise/Vibration**.

Vehicle with a manual transmission. GO to **Symptom Chart — Transmission (Manual) Operation**.

Operating Condition—Vehicle is Moving

1. Depends more on how the vehicle is operated

1 Speed related

■ Related to vehicle speed

- Pitch increases with vehicle speed. GO to **Symptom Chart — Tire Noise/Vibration**.
- Noise occurs at specific vehicle speed. A high-pitched noise (whine). GO to **Symptom Chart — Driveline Noise/Vibration**.
- Loudness proportional to vehicle speed. Low-frequency noise at high speeds, noise and loudness increase with speed. GO to **Symptom Chart — Driveline Noise/Vibration**.
- A low-pitched noise (drumming). GO to **Symptom Chart — Engine Noise/Vibration**.
- Vibration occurs at a particular speed (mph) regardless of acceleration or deceleration. GO to **Symptom Chart — Tire Noise/Vibration**.
- Noise varies with wind/vehicle speed and direction. GO to **Symptom Chart — Air Leak and Wind Noise**.

■ Related to engine speed.

- Noise varies with engine rpm. GO to **Symptom Chart — Engine Noise/Vibration**.
- Vibration occurs at a particular speed (mph) regardless of engine speed (rpm).

2 Acceleration

■ Wide open throttle (WOT)

- Engine induced contact between components. Inspect and repair as necessary.
- Noise is continuous throughout WOT. Exhaust system or engine ground out. GO to **Symptom Chart — Engine Noise/Vibration**.

DIAGNOSIS AND TESTING (Continued)

- Light/moderate acceleration
 - Tip-in moan. Engine/exhaust noise. GO to **Symptom Chart — Engine Noise/Vibration.**
 - Knock-type noise. GO to **Symptom Chart — Engine Noise/Vibration.**
 - Driveline shudder. GO to **Symptom Chart — Driveline Noise/Vibration.**
 - Engine vibration. GO to **Symptom Chart — Engine Noise/Vibration.**
- 3 Turning noise GO to **Symptom Chart — Steering Noise/Vibration.**
- 4 Braking
 - Clicking sound is signaling ABS is active. Acceptable ABS sound.
 - A continuous grinding/squeal. GO to **Symptom Chart — Brake Noise/Vibration.**
 - Brake vibration/shudder. GO to **Symptom Chart — Brake Noise/Vibration.**
- 5 Clutching
 - A noise occurring during clutch operation. GO to **Symptom Chart — Transmission (Manual) and Transfer Case Noise/Vibration.**
 - Vibration. GO to **Symptom Chart — Transmission (Manual) and Transfer Case Noise/Vibration.**
- 6 Shifting
 - Noise or vibration condition related to the transmission (automatic). GO to **Symptom Chart — Transmission (Automatic) Noise/Vibration.**
 - Noise or vibration related to the transmission (manual). GO to **Symptom Chart — Transmission (Manual) and Transfer Case Noise/Vibration.**
- 7 Engaged in four-wheel drive. GO to **Symptom Chart — Transmission (Manual) and Transfer Case Noise/Vibration.**
- 8 Cruising speeds
 - Accelerator pedal vibration. GO to **Symptom Chart — Engine Noise/Vibration.**
 - Driveline vibration. GO to **Symptom Chart — Driveline Noise/Vibration.**
 - A shimmy or shake. GO to **Symptom Chart — Tire Noise/Vibration.**
- 9 Driving at low/medium speeds
 - A wobble or shudder. GO to **Symptom Chart — Tire Noise/Vibration.**
- 2. Depends more on where the vehicle is operated
 - 1 Bump/pothole, rough road or smooth road. GO to **Symptom Chart — Suspension Noise/Vibration.**
 - Noise is random or intermittent occurring from road irregularities. GO to **Symptom Chart — Squeak and Rattle.**
 - Noise or vibration changes from one road surface to another. Normal sound changes.
 - Noise or vibration associated with a hard/firm ride. GO to **Symptom Chart — Suspension Noise/Vibration.**

Symptom Charts

Symptom Chart — Air Leak and Wind Noise

Condition	Possible Sources	Action
<ul style="list-style-type: none"> • Air leak around door perimeter 	<ul style="list-style-type: none"> • Loose fit seal. • Seal installed incorrectly. • Door misaligned. • Scuff plate installed incorrectly. • Seal or seal push pins damaged. 	<ul style="list-style-type: none"> • PINCH the seal carrier to improve retention on the seal flange. • REINSTALL the seal. • REALIGN the door. CHECK door gaps and fit in the door opening and ADJUST as necessary. • REINSTALL the scuff plate. • INSTALL a new seal.

DIAGNOSIS AND TESTING (Continued)**Symptom Chart — Air Leak and Wind Noise (Continued)**

Condition	Possible Sources	Action
<ul style="list-style-type: none"> Air leak around glass run 	<ul style="list-style-type: none"> Door glass misaligned. Glass run installed incorrectly. Leak path behind glass run. Glass run channel spread wide. Blow-out clip bent or contacting door glass. Glass run damaged. 	<ul style="list-style-type: none"> ADJUST the door glass. ADJUST the glass run. INSERT foam in the glass run carrier. INSTALL foam rope behind the glass run. PINCH the glass run channel to reduce the size of the opening. ADJUST the blow-out clip or INSTALL a new glass run/blow-out clip molding assembly. INSTALL a new glass run.
<ul style="list-style-type: none"> Air leak at inner belt line 	<ul style="list-style-type: none"> Belt line seal installed incorrectly on flange. Belt line seal integrated with door trim installed incorrectly (no glass contact). No contact with side glass. No contact with glass runs at both ends of belt line seal. Belt line seal damaged. 	<ul style="list-style-type: none"> ADJUST the seal. (Do not bend the flange.) REINSTALL the door trim. ADJUST the door glass. ADJUST the belt line seal or ADD foam at the seal ends. INSTALL a new seal.
<ul style="list-style-type: none"> Air leak at outer belt line 	<ul style="list-style-type: none"> Belt line seal installed incorrectly on flange (no glass contact). Belt line seal does not contact the glass. No contact with glass runs at both ends of belt line seal. Belt line seal damaged. 	<ul style="list-style-type: none"> ADJUST the seal. ADJUST the door glass. ADJUST the belt line seal/ADD foam at the seal ends. INSTALL a new seal.
<ul style="list-style-type: none"> Draft at inner door handle/speaker opening 	<ul style="list-style-type: none"> Hole in watershield. Watershield misaligned. Exterior door handle seal misaligned/damaged. 	<ul style="list-style-type: none"> SEAL the hole with a suitable tape. REALIGN the watershield. INSTALL a new watershield if the pressure sensitive adhesive fails. REALIGN or INSTALL a new seal as necessary.



BUY IT NOW!

Click Here To Order



DIAGNOSIS AND TESTING (Continued)**Symptom Chart — Air Leak and Wind Noise (Continued)**

Condition	Possible Sources	Action
<ul style="list-style-type: none"> Wind noise from side view mirror 	<ul style="list-style-type: none"> Outside mirror housing misaligned. Mirror sail gasket folded/misaligned. Mirror housing trim cap installed incorrectly. Air leak through mirror housing hinge. Inner sail trim installed incorrectly. Inner sail gasket/barrier installed incorrectly. Air path through wiring bundle/fastener access holes. Exposed fastener access hole on mirror housing/sail. 	<ul style="list-style-type: none"> REALIGN with the edges shingled correctly and no gaps. REINSTALL with the gasket unfolded and aligned correctly. REINSTALL with the edges shingled to the air flow. Fully ENGAGE the mirror into its operating position/USE foam to block the air path through the hinge. REINSTALL the sail trim/ADJUST the door trim. REINSTALL the trim cover with the gasket/barrier aligned correctly. BLOCK the air path(s) with foam/tape. INSTALL a new cap if it is missing.
<ul style="list-style-type: none"> Air leak around perimeter of fixed glass 	<ul style="list-style-type: none"> Gaps in the sealant bead. Air traveling up windshield molding along A-pillar. Windshield/backlite misaligned or not installed correctly. Rear hood seal at base of windshield misaligned/damaged. 	<ul style="list-style-type: none"> APPLY approved sealant. INSTALL foam rope the full length of the A-pillar. REINSTALL the windshield/backlite. REALIGN or INSTALL a new seal as necessary.
<ul style="list-style-type: none"> Air leak at cowl 	<ul style="list-style-type: none"> Cowl gasket misaligned/damaged. 	<ul style="list-style-type: none"> REALIGN or INSTALL a new seal as necessary.
<ul style="list-style-type: none"> Air leak around liftgate perimeter 	<ul style="list-style-type: none"> Loose fit seal. Seal misaligned. Liftgate misaligned. Scuff plate misaligned. Seal or seal push pins damaged. 	<ul style="list-style-type: none"> PINCH the seal carrier to improve retention on the seal flange or INSERT foam in the carrier. REINSTALL the seal. REALIGN the liftgate. CHECK the liftgate fit in the body opening and ADJUST as necessary. REINSTALL the scuff plate. INSTALL a new seal.
<ul style="list-style-type: none"> Air leak around the liftgate flip window perimeter 	<ul style="list-style-type: none"> Loose fit seal. Seal misaligned. Glass misaligned. Seal damaged. 	<ul style="list-style-type: none"> PINCH the seal carrier to improve the retention to the seal flange. REINSTALL the seal. REALIGN the glass. INSTALL a new seal.
<ul style="list-style-type: none"> Wind noise from antenna 	<ul style="list-style-type: none"> Shape of antenna. Air leak around antenna cable access hole. 	<ul style="list-style-type: none"> INSTALL an antenna boot or a spiral antenna. INSPECT the antenna access hole grommet. REPAIR as necessary.



BUY IT NOW!

Click Here To Order



DIAGNOSIS AND TESTING (Continued)**Symptom Chart — Air Leak and Wind Noise (Continued)**

Condition	Possible Sources	Action
<ul style="list-style-type: none"> Air leak from closed roof opening panel 	<ul style="list-style-type: none"> Seal installed incorrectly. Roof opening panel glass/door misaligned. Roof opening panel damaged. 	<ul style="list-style-type: none"> REINSTALL the seal. REALIGN the roof opening panel glass/door. INSTALL a new roof opening panel.
<ul style="list-style-type: none"> Buffeting from an open roof opening panel 	<ul style="list-style-type: none"> Wind deflector inoperative/damaged. Wind deflector height incorrect. 	<ul style="list-style-type: none"> REPAIR or INSTALL a new wind deflector as necessary. ADJUST the wind deflector higher.
<ul style="list-style-type: none"> Wind noise created by airflow over or behind body panels 	<ul style="list-style-type: none"> Fender splash shield misaligned. Body panel misaligned (exposed edge). Hood misaligned (front margin). Front grille edge noise. 	<ul style="list-style-type: none"> REALIGN the fender splash shield. REALIGN the appropriate body panel. CHECK hood gaps and fit. ADJUST the hood as necessary. APPLY foam in the hollow areas behind the louvers.
<ul style="list-style-type: none"> Wind noise created by grille opening panel 	<ul style="list-style-type: none"> Grille relationship to leading edge on hood. Sharp edges due to material imperfections. 	<ul style="list-style-type: none"> ADJUST the grille opening panel forward to eliminate wind noise. REMOVE the sharp edges (no damage to visible surface).
<ul style="list-style-type: none"> Wind noise from air extractor 	<ul style="list-style-type: none"> Air extractor housing seated incorrectly. Air extractor housing or flaps damaged. 	<ul style="list-style-type: none"> REINSTALL the air extractor housing. INSTALL a new air extractor.
<ul style="list-style-type: none"> Air leak at top of A-pillar — vehicles with a convertible top 	<ul style="list-style-type: none"> Seal at windshield header installed incorrectly. Seal pinched. Gap between side rail and header seal at A-pillar. 	<ul style="list-style-type: none"> REINSTALL the seal. FILL the seal with foam to reshape it. ADJUST the J-hook/vinyl top.
<ul style="list-style-type: none"> Air leak at rear quarter glass (division bar) — vehicles with a convertible top 	<ul style="list-style-type: none"> No contact between front side glass and quarter glass division bar. 	<ul style="list-style-type: none"> ADJUST the front side glass regulator and the rear quarter glass regulator.
<ul style="list-style-type: none"> Air leak or wind noise from top of side glass — vehicles with a convertible top 	<ul style="list-style-type: none"> Gap between side rail and vinyl top. Seal at windshield header installed incorrectly. Seal damaged between side rail and vinyl top. Vinyl top damaged. 	<ul style="list-style-type: none"> ADD additional foam tape to seal between the side rail and the vinyl top. REINSTALL the seal. INSTALL a new seal. INSPECT the vinyl top. INSTALL a new vinyl top as necessary.
<ul style="list-style-type: none"> Air leak or wind noise at windshield header — vehicles with a convertible top 	<ul style="list-style-type: none"> Vinyl top not flush with header. Seal at windshield header installed incorrectly. Header seal not flush with header. 	<ul style="list-style-type: none"> ADJUST the J-hook to lower the top to achieve a flush condition. REINSTALL the seal. REINSTALL the seal.



BUY IT NOW!

Click Here To Order



DIAGNOSIS AND TESTING (Continued)**Symptom Chart — Air Leak and Wind Noise (Continued)**

Condition	Possible Sources	Action
<ul style="list-style-type: none"> Convertible top flapping with the top up 	<ul style="list-style-type: none"> Vinyl top contacting interior headliner. 	<ul style="list-style-type: none"> Working from front to back, INSTALL a 6.35 mm (0.25 in) foam sheet between the headliner and the vinyl top at the suspected area. Allow a clearance of 50 mm (2 in) - 75 mm (3 in) away from the roof bows and the side rails.
<ul style="list-style-type: none"> Noise from roof rack 	<ul style="list-style-type: none"> Roof rack rails or crossbars loose. Roof rack fasteners missing. Roof rack crossbars installed backward. Roof rack rub strips partially lifting from roof. Roof rack gaskets loose or misaligned. 	<ul style="list-style-type: none"> TIGHTEN the fasteners. INSTALL the approved fasteners. REINSTALL the crossbars. REAPPLY adhesive or fasteners or INSTALL new rub strips as necessary. REINSTALL the gasket.
<ul style="list-style-type: none"> Wind noise from bug shield/exterior windshield sun visor 	<ul style="list-style-type: none"> Turbulence created by location and shape. 	<ul style="list-style-type: none"> REMOVE per customer direction if it is a dealer installed option.

Symptom Chart—Brake Noise/Vibration

Condition	Possible Sources	Action
<ul style="list-style-type: none"> Rattling noise 	<ul style="list-style-type: none"> Caliper mounting bolts loose. Damaged or worn caliper pins or retainers. Missing or damaged anti-rattle clips or springs. Loose brake disc shield. 	<ul style="list-style-type: none"> CHECK the caliper bolts. TIGHTEN to specifications. REFER to Section 206-03 for front disc brakes or Section 206-04 for rear disc brakes. CHECK the caliper pins and retainers for lubrication and correct fit. LUBRICATE or INSTALL new components as necessary. REFER to Section 206-03 for front disc brakes or Section 206-04 for rear disc brakes. CHECK the brake pads for missing clips or broken springs. INSTALL new components as necessary. REFER to Section 206-03 for front disc brakes or Section 206-04 for rear disc brakes. TIGHTEN the brake disc shield bolts to specification. REFER to Section 206-03.
<ul style="list-style-type: none"> Clicking noise—with brakes applied with ABS brakes 	<ul style="list-style-type: none"> ABS hydraulic control unit. 	<ul style="list-style-type: none"> Acceptable condition.
<ul style="list-style-type: none"> Squealing noise—occurs on first (morning) brake 	<ul style="list-style-type: none"> Disc brake pads. 	<ul style="list-style-type: none"> Acceptable condition. Caused by humidity and low disc brake pad temperature.



BUY IT NOW!

Click Here To Order



DIAGNOSIS AND TESTING (Continued)**Symptom Chart—Brake Noise/Vibration (Continued)**

Condition	Possible Sources	Action
<ul style="list-style-type: none"> Squealing noise—a continuous squeal 	<ul style="list-style-type: none"> Disc brake pads or linings worn below minimum thickness. 	<ul style="list-style-type: none"> INSTALL new disc brake pads. REFER to Section 206-03 for front disc brakes or Section 206-04 for rear disc brakes.
<ul style="list-style-type: none"> Squealing noise—an intermittent squeal brought on by cold, heat, water, mud or snow 	<ul style="list-style-type: none"> Disc brake pad. 	<ul style="list-style-type: none"> Acceptable condition.
<ul style="list-style-type: none"> Groaning noise—occurs at low speeds with brake lightly applied (creeping) 	<ul style="list-style-type: none"> Disc brake pads. 	<ul style="list-style-type: none"> Acceptable condition.
<ul style="list-style-type: none"> Grinding noise—continuous 	<ul style="list-style-type: none"> Disc brake pads or linings worn below minimum thickness. 	<ul style="list-style-type: none"> INSPECT the disc brake pads, brake discs/drums and attaching hardware for damage. REPAIR or INSTALL new components as necessary. REFER to Section 206-03 for front disc brakes or Section 206-04 for rear disc brakes.
<ul style="list-style-type: none"> Moaning noise 	<ul style="list-style-type: none"> Brake linings contaminated with grease or oil. 	<ul style="list-style-type: none"> INSPECT the brake pads and shoes for contamination. REPAIR or INSTALL new components as necessary. REFER to Section 206-03 for front disc brakes or Section 206-04 for rear disc brakes.
<ul style="list-style-type: none"> Brake vibration/shudder—occurs when brakes are applied 	<ul style="list-style-type: none"> Uneven disc or drum wear. Uneven disc brake pad or lining transfer. Suspension components. 	<ul style="list-style-type: none"> GO to Pinpoint Test A.
<ul style="list-style-type: none"> Brake vibration/shudder—occurs when the brake pedal is released 	<ul style="list-style-type: none"> Brake drag. 	<ul style="list-style-type: none"> INSPECT the disc brake pads or linings for premature wear. REPAIR or INSTALL a new caliper or wheel cylinder as necessary. REFER to Section 206-03 for front disc brakes or Section 206-04 for rear disc brakes.



BUY IT NOW!
Click Here To Order



DIAGNOSIS AND TESTING (Continued)

Symptom Chart—Driveline Noise/Vibration

Condition	Possible Sources	Action
<ul style="list-style-type: none"> Axle howling or whine—front or rear axle 	<ul style="list-style-type: none"> Axle lubricant low. Axle housing damage. Damaged or worn wheel bearings or axle bearings. Damaged or worn differential ring and pinion. Damaged or worn differential side or pinion bearings. Damaged or worn differential side gears and pinion gears. 	<ul style="list-style-type: none"> CHECK the lubricant level. FILL the axle to specification. INSPECT the axle housing for damage. REPAIR or INSTALL a new axle as necessary. REFER to Section 205-02A for Ford 8.8 rear axles, Section 205-02B for Ford 9.75 rear axles, Section 205-02C for Ford 10.25 rear axles or Section 205-03 for front axles. CHECK for abnormal wheel bearing play or roughness. REFER to Wheel Bearing Check in this section. ADJUST or INSTALL new wheel bearings as necessary. INSPECT the ring and pinion ring for abnormal wear patterns or broken teeth. INSTALL a new ring and pinion as necessary. REFER to Section 205-02A for Ford 8.8 rear axles, Section 205-02B for Ford 9.75 rear axles, Section 205-02C for Ford 10.25 rear axles or Section 205-03 for front axles. CHECK for abnormal bearing play or roughness. INSTALL new bearings as necessary. REFER to Section 205-02A for Ford 8.8 rear axles, Section 205-02B for Ford 9.75 rear axles, Section 205-02C for Ford 10.25 rear axles or Section 205-03 for front axles. DISASSEMBLE the differential carrier. INSPECT the side and pinion gears for abnormal wear patterns or broken teeth. INSTALL new gears as necessary. REFER to Section 205-02A for Ford 8.8 rear axles, Section 205-02B for Ford 9.75 rear axles, Section 205-02C for Ford 10.25 rear axles or Section 205-03 for front axles.



BUY IT NOW!

Click Here To Order



DIAGNOSIS AND TESTING (Continued)

Symptom Chart—Driveline Noise/Vibration (Continued)

Condition	Possible Sources	Action
<ul style="list-style-type: none"> • Driveline clunk—loud clunk when shifting from reverse to drive 	<ul style="list-style-type: none"> • Incorrect axle lubricant level. • Excessive backlash in the axle or transmission. • Damaged or worn pinion bearings. • Damaged or worn universal joints (U-joints). • Loose suspension components. • Broken powertrain mounts. • Idle speed too high. 	<ul style="list-style-type: none"> • CHECK the lubricant level. FILL the axle to specification. • CARRY OUT a total backlash check. REFER to Section 205-00. • CHECK for abnormal bearing play or roughness. INSTALL new bearings as necessary. REFER to Section 205-02A for Ford 8.8 rear axles, Section 205-02B for Ford 9.75 rear axles, Section 205-02C for Ford 10.25 rear axles or Section 205-03 for front axles. • INSPECT the U-joints for wear or damage. INSTALL new U-joints as necessary. REFER to Section 205-01. • INSPECT the suspension for damage or wear. REPAIR or INSTALL new components as necessary. • INSPECT the powertrain mounts. REFER to Section 303-01A for 4.2L engines or Section 303-01B for 4.6L and 5.4L engines. INSTALL new mounts as necessary. • CHECK for the correct idle speed.
<ul style="list-style-type: none"> • Driveline clunk—occurs as the vehicle starts to move forward following a stop 	<ul style="list-style-type: none"> • Worn or galled driveshaft slip-yoke splines. • Worn or galled driveshaft and coupling shaft splines. • Loose rear leaf spring U-bolts. 	<ul style="list-style-type: none"> • CLEAN and INSPECT the splines of the yoke for a worn or galled condition. INSTALL a new yoke as necessary. REFER to Section 205-01. • CLEAN and INSPECT the splines of the driveshaft and coupling shaft for a worn or galled condition. INSTALL a new driveshaft assembly as necessary. REFER to Section 205-01. • CHECK the U-bolts for loose nuts. TIGHTEN to specification. REFER to Section 204-02.
<ul style="list-style-type: none"> • Driveline clunk (FWD vehicles)—occurs during acceleration or from cruise to coast/deceleration 	<ul style="list-style-type: none"> • Damaged or worn inboard constant velocity (CV) joint. 	<ul style="list-style-type: none"> • INSPECT the inboard CV joint and boot. REPAIR or INSTALL a new CV joint as necessary.
<ul style="list-style-type: none"> • Driveline clunk (4WD vehicles)—occurs during 	<ul style="list-style-type: none"> • Clutch relay. • Shift motor. • Transfer case. • GEM. 	<ul style="list-style-type: none"> • CHECK the 4WD engagement system. REPAIR or INSTALL new components as necessary. REFER to Section 308-07A and Section 308-07B.

100% SATISFACTION GUARANTEED

BUY IT NOW!

Click Here To Order



DIAGNOSIS AND TESTING (Continued)**Symptom Chart—Driveline Noise/Vibration (Continued)**

Condition	Possible Sources	Action
<ul style="list-style-type: none"> Clicking, popping or grinding—occurs while vehicle is turning 	<ul style="list-style-type: none"> Inadequate or contaminated lubrication in the (CV) joints. Another component contacting the halfshaft. Brake components. Steering components. Suspension components. Damaged or worn wheel bearings. 	<ul style="list-style-type: none"> CHECK the CV boots and joints for wear or damage. REPAIR or INSTALL new components as necessary. REFER to Section 205-04. CHECK the halfshafts and the area around the halfshafts. REPAIR as necessary. INSPECT the front brakes for wear or damage. REPAIR as necessary. REFER to Section 206-03. INSPECT the drag link, inner and outer tie-rods or idler arm for wear or damage. REPAIR as necessary. REFER to Section 211-03. INSPECT the upper and lower ball joints for wear or damage. REPAIR as necessary. REFER to Section 204-01A for 2-wheel drive vehicles or Section 204-01B for 4-wheel drive vehicles. CHECK for abnormal wheel bearing play or roughness. REFER to Wheel Bearing Check in this section. ADJUST or INSTALL new wheel bearings as necessary.
<ul style="list-style-type: none"> Clicking or snapping—occurs when accelerating around a corner 	<ul style="list-style-type: none"> Damaged or worn outboard CV joint. 	<ul style="list-style-type: none"> INSPECT the outboard CV joint and boot. REPAIR or INSTALL a new CV joint as necessary. REFER to Section 205-04.
<ul style="list-style-type: none"> High pitched chattering—noise from the rear axle when the vehicle is turning 	<ul style="list-style-type: none"> Incorrect or contaminated lubricant. Damaged or worn differential (differential side gears and pinion gears). 	<ul style="list-style-type: none"> CHECK the vehicle by driving in tight circles (5 clockwise, 5 counterclockwise). FLUSH and REFILL with the specified rear axle lubricant and friction modifier as necessary. DISASSEMBLE the differential assembly. INSPECT the differential case, pin and gears for wear or damage. REPAIR or INSTALL a new differential as necessary. REFER to Section 205-02A for Ford 8.8 rear axles, Section 205-02B for Ford 9.75 rear axles, Section 205-02C for Ford 10.25 rear axles or Section 205-03 for front axles.



BUY IT NOW!

Click Here To Order



DIAGNOSIS AND TESTING (Continued)**Symptom Chart—Driveline Noise/Vibration (Continued)**

Condition	Possible Sources	Action
<ul style="list-style-type: none"> Buzz—buzzing noise is the same at cruise or coast/deceleration 	<ul style="list-style-type: none"> Damaged or worn tires. Incorrect driveline angles. 	<ul style="list-style-type: none"> CHECK for abnormal tire wear or damage. INSTALL new tire(s) as necessary. REFER to Section 204-04. CHECK for correct driveline angles. REPAIR as necessary. REFER to Section 205-00.
<ul style="list-style-type: none"> Rumble or boom—noise occurs at coast/deceleration, usually driveshaft speed related and noticeable over a wide range of speeds 	<ul style="list-style-type: none"> Driveshaft is out-of-balance. U-joints binding or seized. Excessive pinion flange runout. 	<ul style="list-style-type: none"> CHECK the driveshaft for damage, missing balance weights or undercoating. CHECK the driveshaft balance. CARRY OUT a driveline vibration test. REFER to Section 205-00. ROTATE the driveshaft and CHECK for rough operation or seized U-joints. INSTALL new U-joints as necessary. REFER to Section 205-01. CARRY OUT a runout check. REPAIR as necessary. REFER to Section 205-00.
<ul style="list-style-type: none"> Grunting—normally associated with a shudder experienced during acceleration from a dead stop 	<ul style="list-style-type: none"> Driveshaft slip yoke binding. Loose rear spring U-bolts. 	<ul style="list-style-type: none"> CLEAN and LUBRICATE the male and female splines. INSPECT the rear suspension. TIGHTEN the U-bolt nuts to specification. REFER to Section 204-02.
<ul style="list-style-type: none"> Howl—can occur at various speeds and driving conditions. Affected by acceleration and deceleration 	<ul style="list-style-type: none"> Incorrect ring and pinion contact, incorrect bearing preload or gear damage. 	<ul style="list-style-type: none"> CHECK the ring and pinion and bearings for damage. INSPECT the ring and pinion wear pattern. REFER to Checking Tooth Contact Pattern and Condition of the Ring and Pinion component test in this section. ADJUST or INSTALL new components as necessary. REFER to Section 205-02A for Ford 8.8 rear axles, Section 205-02B for Ford 9.75 rear axles, Section 205-02C for Ford 10.25 rear axles or Section 205-03 for front axles.



BUY IT NOW!
Click Here To Order



DIAGNOSIS AND TESTING (Continued)**Symptom Chart—Driveline Noise/Vibration (Continued)**

Condition	Possible Sources	Action
<ul style="list-style-type: none"> • Chuckle—heard at coast/deceleration. Also described as a knock 	<ul style="list-style-type: none"> • Incorrect ring and pinion contact or by damaged teeth on the coast side of the ring and pinion. 	<ul style="list-style-type: none"> • CHECK the ring and pinion for damage. INSPECT the ring and pinion wear pattern. REFER to Checking Tooth Contact Pattern and Condition of the Ring and Pinion component test in this section. ADJUST or INSTALL new components as necessary. REFER to Section 205-02A for Ford 8.8 rear axles, Section 205-02B for Ford 9.75 rear axles Section 205-02C for Ford 10.25 rear axles or Section 205-03 for front axles.
<ul style="list-style-type: none"> • Knock—noise occurs at various speeds. Not affected by acceleration or deceleration 	<ul style="list-style-type: none"> • Gear tooth damage to the drive side of the ring and pinion. • Excessive axle shaft end play. (Vehicles with integral axles). 	<ul style="list-style-type: none"> • CHECK the differential case and ring and pinion for damage. INSTALL new components as necessary. REFER to Section 205-02A for Ford 8.8 rear axles, Section 205-02B for Ford 9.75 rear axles, Section 205-02C for Ford 10.25 rear axles or Section 205-03 for front axles. • CHECK the axle end play using a dial indicator. INSTALL a new axle shaft or side gears as necessary. REFER to Section 205-02A for Ford 8.8 rear axles, Section 205-02B for Ford 9.75 rear axles, Section 205-02C for Ford 10.25 rear axles or Section 205-03 for front axles.
<ul style="list-style-type: none"> • Scraping noise—a continuous low pitched noise starting at low speeds 	<ul style="list-style-type: none"> • Worn or damaged pinion bearings. 	<ul style="list-style-type: none"> • CHECK the pinion bearings. INSTALL new pinion bearings as necessary. REFER to Section 205-02A for Ford 8.8 rear axles, Section 205-02B for Ford 9.75 rear axles, Section 205-02C for Ford 10.25 rear axles or Section 205-03 for front axles.



BUY IT NOW!

Click Here To Order



DIAGNOSIS AND TESTING (Continued)**Symptom Chart—Driveline Noise/Vibration (Continued)**

Condition	Possible Sources	Action
<ul style="list-style-type: none"> • Driveline shudder—occurs during acceleration from a slow speed or stop 	<ul style="list-style-type: none"> • Rear drive axle assembly mispositioned. • Loose rear spring U-bolts. • Incorrect or high CV joint operating angle. • Damaged or worn front suspension components. • Driveline angles out of specification. • U-joints binding or seized. • Binding, damaged or galled splines on the driveshaft slip-yoke. 	<ul style="list-style-type: none"> • CHECK the axle mounts and the rear suspension for damage or wear. REPAIR as necessary. • INSPECT the U-bolts. TIGHTEN the U-bolt nuts to specification. REFER to Section 204-02. • CHECK vehicle ride height is within limits. REPAIR as necessary. • CHECK for a loose stabilizer bar, damaged or loose strut/strut bushings or loose or worn ball joints. INSPECT the steering linkage for wear or damage. REPAIR or INSTALL new components as necessary. • CHECK for correct driveline angles. REPAIR as necessary. REFER to Section 205-00. • ROTATE the driveshaft and CHECK for rough operation or seized U-joints. INSTALL new U-joints as necessary. REFER to Section 205-01. • CLEAN and INSPECT the splines of the slip-yoke, driveshaft and coupling shaft for a worn, damaged or galled condition. INSTALL a new slip-yoke or driveshaft assembly as necessary. REPAIR as necessary. REFER to Section 205-01.



BUY IT NOW!

Click Here To Order

PayPal

AMERICAN EXPRESS
Cards

DISCOVER
NEWUS

MasterCard

VISA

DIAGNOSIS AND TESTING (Continued)**Symptom Chart—Driveline Noise/Vibration (Continued)**

Condition	Possible Sources	Action
<ul style="list-style-type: none"> • Driveline vibration—occurs at cruising speeds 	<ul style="list-style-type: none"> • U-joints are worn. • Worn or damaged driveshaft center bearing support. • Loose axle pinion flange bolts. • Excessive axle pinion flange runout. • Driveshaft is out-of-balance. • Binding or damaged splines on the driveshaft slip-yoke. • Driveshaft runout. • Incorrect lateral and radial tire/wheel runout. • Driveline angles out of specification. • Incorrectly seated CV joint in the front wheel hub. 	<ul style="list-style-type: none"> • CHECK for wear or incorrect seating. INSTALL new U-joints as necessary. REFER to Section 205-01. • CHECK the insulator for damage or wear. ROTATE the driveshaft and CHECK for rough operation. INSTALL a new center bearing support as necessary. REFER to Section 205-01. • INSPECT the axle pinion flange. TIGHTEN the pinion flange bolts to specification. REFER to Section 205-01. • CARRY OUT a Runout Check. REPAIR as necessary. REFER to Section 205-01. • CHECK the driveshaft for damage, missing balance weights or undercoating. CHECK driveshaft balance. CARRY OUT a driveline vibration test. REFER to Section 205-00. REPAIR as necessary. • CLEAN and INSPECT the splines of the slip-yoke, driveshaft and coupling shaft for wear or damage. INSTALL a new slip-yoke or driveshaft assembly as necessary. REFER to Section 205-01. REPAIR as necessary. • CARRY OUT a Runout Check. REFER to Section 205-00. REPAIR as necessary. • INSPECT the tire and wheels. MEASURE tire runouts. REPAIR or INSTALL new components as necessary. REFER to Section 204-04. • CHECK for correct driveline angles. REPAIR as necessary. REFER to Section 205-00. • CHECK the outer CV joint for correct seating into the hub. REPAIR as necessary. REFER to Section 205-04.



BUY IT NOW!

Click Here To Order



DIAGNOSIS AND TESTING (Continued)**Symptom Chart — Engine Noise/Vibration**

Condition	Possible Sources	Action
<ul style="list-style-type: none"> Grinding noise—occurs during engine cranking 	<ul style="list-style-type: none"> Incorrect starter motor mounting. Starter motor. Incorrect starter motor drive engagement. 	<ul style="list-style-type: none"> INSPECT the starter motor for correct mounting. REPAIR as necessary. REFER to Section 303-06. CHECK the starter motor. REPAIR or INSTALL a new starter motor as necessary. REFER to Section 303-06. INSPECT the starter motor drive and flexplate/flywheel for wear or damage. INSTALL a new starter motor drive or flexplate/flywheel as necessary. REFER to Section 303-06.
<ul style="list-style-type: none"> Engine ticking noise 	<ul style="list-style-type: none"> Fuel injector. Fuel line. Oil pump. Valve lifter. Belt tensioner. Water pump. Obstruction of cooling fan. 	<ul style="list-style-type: none"> GO to Pinpoint Test B.
<ul style="list-style-type: none"> Engine drumming noise—normally accompanied by vibration 	<ul style="list-style-type: none"> Powertrain mount. Damaged or misaligned exhaust system. 	<ul style="list-style-type: none"> CARRY OUT Powertrain/Drivetrain Mount Neutralizing in this section. INSPECT the exhaust system for loose or broken clamps and brackets. CARRY OUT Exhaust System Neutralizing in this section.
<ul style="list-style-type: none"> Whistling noise—normally accompanied with poor idle condition 	<ul style="list-style-type: none"> Air intake system. 	<ul style="list-style-type: none"> CHECK the air intake ducts, air cleaner, throttle body and vacuum hoses for leaks and correct fit. REPAIR or ADJUST as necessary. REFER to Section 303-12.
<ul style="list-style-type: none"> Clunking noise 	<ul style="list-style-type: none"> Water pump has excessive end play or imbalance. Generator has excessive end play. 	<ul style="list-style-type: none"> CHECK the water pump for excessive end play. INSPECT the water pump with the drive belt off for imbalance. INSTALL a new water pump as necessary. REFER to Section 303-03A for standard cooling or Section 303-03B for supercharger cooling. CHECK the generator for excessive end play. REPAIR or INSTALL a new generator. REFER to Section 414-02.



BUY IT NOW!
Click Here To Order



DIAGNOSIS AND TESTING (Continued)**Symptom Chart — Engine Noise/Vibration (Continued)**

Condition	Possible Sources	Action
<ul style="list-style-type: none"> Pinging noise 	<ul style="list-style-type: none"> Exhaust system leak. Gasoline octane too low. Knock sensor operation. Incorrect spark timing. High operating temperature. Foul-out spark plug. Catalytic converter. 	<ul style="list-style-type: none"> INSPECT the exhaust system for leaks. REPAIR as necessary. VERIFY with customer the type of gasoline used. CORRECT as necessary. CHECK the knock sensor. INSTALL a new knock sensor as necessary. REFER to Section 303-14. CHECK the spark timing. REPAIR as necessary. INSPECT cooling system for leaks. CHECK the coolant level. REFILL as necessary. CHECK the coolant for the correct mix ratio. DRAIN and REFILL as needed. CHECK engine operating temperature is within specifications. REPAIR as necessary. CHECK the spark plugs. REPAIR or INSTALL new spark plugs as necessary. Acceptable noise.
<ul style="list-style-type: none"> Knocking noise—light knocking noise, also described as piston slap. Noise is most noticeable when engine is cold with light to medium acceleration. Noise disappears as engine warms 	<ul style="list-style-type: none"> Excessive clearance between the piston and the cylinder wall. 	<ul style="list-style-type: none"> Engine cold and at high idle. Using an EngineEAR, pull a spark plug or fuel injector connector until the noise goes away. CARRY OUT a cylinder bore clearance to piston check. INSTALL a new piston. REFER to Section 303-01A for 4.2L engines or Section 303-01B for 4.6L and 5.4L engines.
<ul style="list-style-type: none"> Knocking noise—light double knock or sharp rap sound. Occurs mostly with warm engine at idle or low speeds in DRIVE. Increases in relation to engine load. Associated with poor lubrication history 	<ul style="list-style-type: none"> Excessive clearance between the piston and the piston pin. 	<ul style="list-style-type: none"> INSTALL a new piston or piston pin. REFER to Section 303-01A for 4.2L engines or Section 303-01B for 4.6L and 5.4L engines.
<ul style="list-style-type: none"> Knocking noise—light knocking noise is most noticeable when engine is warm. Noise tends to decrease when vehicle is coasting or in neutral 	<ul style="list-style-type: none"> Excessive clearance between the connecting rod bearings and the crankshaft. 	<ul style="list-style-type: none"> Engine warm and at idle. Using an EngineEAR, PULL a spark plug or fuel injector connector until the noise goes away. INSTALL new bearings. REFER to Section 303-01A for 4.2L engines or Section 303-01B for 4.6L and 5.4L engines.



BUY IT NOW!

Click Here To Order



DIAGNOSIS AND TESTING (Continued)**Symptom Chart — Engine Noise/Vibration (Continued)**

Condition	Possible Sources	Action
<ul style="list-style-type: none"> Knocking—deep knocking noise. Noise is most noticeable when engine is warm, at lower rpm and under a light load and then at float 	<ul style="list-style-type: none"> Worn or damaged crankshaft main bearings. 	<ul style="list-style-type: none"> CARRY OUT Drive Engine Run-Up (DERU) Test. CHECK for noise with vehicle at operating temperature, during medium to heavy acceleration. CHECK at idle with injector disconnected, noise does not change. INSTALL new main bearings. REFER to Section 303-01A for 4.2L engines or Section 303-01B for 4.6L and 5.4L engines.
<ul style="list-style-type: none"> Knocking noise—occurs mostly with warm engine at light/medium acceleration 	<ul style="list-style-type: none"> Spark plugs. Carbon accumulation in combustion chamber. 	<ul style="list-style-type: none"> CHECK the spark plugs for damage or wear. INSTALL new spark plugs as necessary. REMOVE carbon from combustion chamber.
<ul style="list-style-type: none"> Whine or moaning noise 	<ul style="list-style-type: none"> Air intake system. Generator electrical field or bearings. 	<ul style="list-style-type: none"> CHECK the air cleaner and ducts for correct fit. INSPECT the air intake system for leaks or damage. REPAIR as necessary. CARRY OUT generator load test. REPAIR or INSTALL a new generator as necessary. REFER to Section 414-02.
<ul style="list-style-type: none"> Drone type noise 	<ul style="list-style-type: none"> Exhaust system. A/C compressor. Powertrain mounts. 	<ul style="list-style-type: none"> CARRY OUT the Exhaust System Neutralizing in this section. REPAIR as necessary. CHECK for noise with vehicle at constant speeds. CYCLE the compressor on and off and listen for a change in pitch. REPAIR as necessary. REFER to Section 412-03. CARRY OUT the Powertrain/Drivetrain Mount Neutralizing in this section.
<ul style="list-style-type: none"> Sputter type noise—noise worse when cold, lessens or disappears when vehicle is at operating temperature 	<ul style="list-style-type: none"> Damaged or worn exhaust system components. 	<ul style="list-style-type: none"> INSPECT the exhaust system for leaks or damage. REPAIR as necessary. REFER to Section 309-00.



SATISFACTION 100% GUARANTEED

BUY IT NOW!

Click Here To Order

PayPal American Express Discover MasterCard VISA

DIAGNOSIS AND TESTING (Continued)**Symptom Chart — Engine Noise/Vibration (Continued)**

Condition	Possible Sources	Action
<ul style="list-style-type: none"> Rattling noise—noise from the upper engine (valve train). Worse when engine is cold 	<ul style="list-style-type: none"> Low oil level. Thin or diluted oil. Low oil pressure. Worn rocker arms/fulcrums or followers. Worn valve guides. Excessive runout of valve seats on the valve face. 	<ul style="list-style-type: none"> CHECK oil level. FILL as necessary. INSPECT the oil for contamination. If oil is contaminated, CHECK for the source. REPAIR as necessary. CHANGE the oil and filter. CARRY OUT an oil pressure test. If not within specifications, REPAIR as necessary. REFER to Section 303-01A for 4.2L engines or Section 303-01B for 4.6L and 5.4L engine. CARRY OUT a valve train analysis. INSTALL new valve train components as necessary. REFER to Section 303-01A for 4.2L engines or Section 303-01B for 4.6L and 5.4L engines. CARRY OUT a valve train analysis. INSTALL new valve guides as necessary. REFER to Section 303-01A for 4.2L engines or Section 303-01B for 4.6L and 5.4L engines. CARRY OUT a valve seat runout test. INSPECT the valve face and seat. INSTALL new valves as necessary. REFER to Section 303-01A for 4.2L engines or Section 303-01B for 4.6L and 5.4L engines.
<ul style="list-style-type: none"> Rattling noise—from the bottom of the vehicle 	<ul style="list-style-type: none"> Loose muffler shields or catalytic converter shields. 	<ul style="list-style-type: none"> CHECK the exhaust system for loose shields. REPAIR as necessary.
<ul style="list-style-type: none"> Thumping noise—from the bottom of the vehicle, worse at acceleration 	<ul style="list-style-type: none"> Exhaust pipe/muffler grounded to chassis. 	<ul style="list-style-type: none"> CHECK the exhaust system to chassis clearance. CHECK the exhaust system hangers for damage. REPAIR as necessary. REFER to Section 309-00.
<ul style="list-style-type: none"> Whoosh—occurs during light vehicle acceleration. Heard inside the vehicle 	<ul style="list-style-type: none"> Throttling late, creating turbulence transmitted through the plastic manifold. 	<ul style="list-style-type: none"> CHECK for leaks or missing seal in the dash panel.



BUY IT NOW!

Click Here To Order



DIAGNOSIS AND TESTING (Continued)**Symptom Chart — Engine Noise/Vibration (Continued)**

Condition	Possible Sources	Action
<ul style="list-style-type: none"> Engine vibration—increases intensity as engine rpm is increased 	<ul style="list-style-type: none"> Engine out-of-balance. 	<ul style="list-style-type: none"> CARRY OUT Neutral Engine Run-Up (NERU) Test. ROTATE the torque converter, 120° for 3 bolt and 180° for 4 bolt. INSPECT the torque converter pilot outer diameter to crankshaft pilot inner diameter. REPAIR as necessary. REFER to Section 307-01A for 4R100 transmissions. REFER to Section 307-01B for 4R70W transmissions.
<ul style="list-style-type: none"> Engine vibration—is felt with increases and decreases in engine rpm 	<ul style="list-style-type: none"> Strain on exhaust mounts. Damaged or worn powertrain/drivetrain mounts. Engine or transmission grounded to chassis. 	<ul style="list-style-type: none"> CARRY OUT the Exhaust System Neutralizing in this section. REPAIR as necessary. CHECK the powertrain/drivetrain mounts for damage. REFER to Section 303-01A for 4.2L engines or Section 303-01B for 4.6L and 5.4L engines. REPAIR as necessary. INSPECT the powertrain/drivetrain for correct clearances. REPAIR as necessary.
<ul style="list-style-type: none"> Engine vibration—vibration felt at all times 	<ul style="list-style-type: none"> Excessive engine pulley runout. Damaged or worn accessory component. 	<ul style="list-style-type: none"> CARRY OUT Engine Accessory Test. INSTALL a new engine pulley as necessary. REFER to Section 303-01A for 4.2L engines or Section 303-01B for 4.6L and 5.4L engines. CARRY OUT Engine Accessory Test. REPAIR or INSTALL a new component as necessary.
<ul style="list-style-type: none"> Accelerator pedal vibration—felt through the pedal as a buzz 	<ul style="list-style-type: none"> Throttle cable loose or misrouted. 	<ul style="list-style-type: none"> INSPECT the throttle cable. REPAIR as necessary. REFER to Section 310-02.
<ul style="list-style-type: none"> Engine vibration—mostly at coast/neutral coast. Condition improves with vehicle accelerating 	<ul style="list-style-type: none"> Combustion instability. 	<ul style="list-style-type: none"> CHECK the ignition system. INSTALL new components as necessary.



BUY IT NOW!

Click Here To Order



DIAGNOSIS AND TESTING (Continued)**Symptom Chart — Engine Noise/Vibration (Continued)**

Condition	Possible Sources	Action
<ul style="list-style-type: none"> Engine vibration or shudder—occurs with light to medium acceleration above 56 km/h (35 mph) 	<ul style="list-style-type: none"> Worn or damaged spark plugs. Plugged fuel injector. Damaged spark plug wire. Contaminated fuel. Worn or damaged torque converter. 	<ul style="list-style-type: none"> INSPECT the spark plugs for cracks, high resistance or broken insulator. INSTALL a new spark plug(s) as necessary. REPAIR or INSTALL a new injector as necessary. INSPECT the spark plug wires for damage. INSTALL a new spark plug wire(s) as necessary. INSPECT the fuel for contamination. DRAIN the fuel system and refill. CHECK the torque converter. INSTALL a new torque converter as necessary. REFER to Section 307-01B for 4R70W transmissions. REFER to Section 307-01A for 4R100 transmissions.

Symptom Chart—Idle Noise/Vibration

Condition	Possible Sources	Action
<ul style="list-style-type: none"> Idle air control (IAC) valve moan — occurs on throttle tip-out 	<ul style="list-style-type: none"> IAC valve is contaminated with oil. 	<ul style="list-style-type: none"> GO to Component Tests in this section.
<ul style="list-style-type: none"> Accessory drive belt chirp — occurs at idle or high idle, cold or hot. Most common occurrence is during humid weather 	<ul style="list-style-type: none"> Accessory drive belt worn, or pulley is misaligned or loose. 	<ul style="list-style-type: none"> INSPECT for loose or misaligned pulleys. CHECK the drive belt for wear or damage. INSTALL new pulley(s)/accessory drive components or drive belt, as necessary. REFER to Section 303-05.
<ul style="list-style-type: none"> Accessory drive bearing hoot — occurs at idle or high idle in cold temperatures of approximately +4°C (+40°F) or colder at first start of the day 	<ul style="list-style-type: none"> Accessory drive idler or tensioner pulley bearing is experiencing stick/slip between ball bearings and bearing race. 	<ul style="list-style-type: none"> GO to Pinpoint Test C.
<ul style="list-style-type: none"> Power steering moan — occurs at high idle and possibly at idle during the first cold start of the day in temperatures of approximately -18°C (0°F) or colder. Noise can even be a severe screech for less than one minute in very cold temperatures of approximately -29°C (-20°F) or colder 	<ul style="list-style-type: none"> High fluid viscosity, or plugged reservoir screen in power steering reservoir starves pump causing cavitation. 	<ul style="list-style-type: none"> GO to Pinpoint Test D.

**BUY IT NOW!****Click Here To Order**

DIAGNOSIS AND TESTING (Continued)**Symptom Chart—Idle Noise/Vibration (Continued)**

Condition	Possible Sources	Action
<ul style="list-style-type: none"> Generator whine — during high electrical loads at idle or high idle, a high pitch whine or moan is emitted from the generator 	<ul style="list-style-type: none"> Generator electrical field noise. 	<ul style="list-style-type: none"> Using an EngineEAR, PROBE near the generator housing. LISTEN for changes in the noise level while changing electrical loads (such as rear defrost, headlamps, etc.). CARRY OUT a generator load test. If the system passes the load test, the noise is from the generator bearings. INSTALL new bearings. If the system fails the load test, INSTALL a new generator. REFER to Section 414-02.
<ul style="list-style-type: none"> Engine-driven cooling fan moan — occurs during the first start of the day. It is most objectionable near idle speeds up to 2000 rpm. The noise increases with rpm 	<ul style="list-style-type: none"> The viscous cooling fan clutch engages until the fluid in the clutch reaches normal operating temperature, causing the fan to fully engage. 	<ul style="list-style-type: none"> GO to Pinpoint Test E.
<ul style="list-style-type: none"> Drumming noise — occurs inside the vehicle during idle or high idle, hot or cold. Very low-frequency drumming is very rpm dependent 	<ul style="list-style-type: none"> Exhaust system vibration excites the body resonances inducing interior noise. Engine vibration excites the body resonances inducing interior noise. 	<ul style="list-style-type: none"> GO to Pinpoint Test F.
<ul style="list-style-type: none"> Hissing noise — occurs during idle or high idle that is apparent with the hood open 	<ul style="list-style-type: none"> Vacuum leak or idle air control (IAC) valve flow noise. Vehicles with a plastic intake manifold. 	<ul style="list-style-type: none"> Use the Ultrasonic Leak Detector/EngineEAR to locate the source. Scan the air intake system from the inlet to each cylinder intake port. DISCARD the leaking parts, and INSTALL a new component. Acceptable condition. Some plastic manifolds exhibit this noise, which is the effect of the plastic manifold.
<ul style="list-style-type: none"> Automatic transmission buzz or hiss 	<ul style="list-style-type: none"> Incorrect driveline angles. Worn or damaged main control solenoids or valves. 	<ul style="list-style-type: none"> CHECK for correct driveline angles. REPAIR as necessary. REFER to Section 205-00. Using a transmission tester, activate the solenoids to duplicate sound. INSTALL new components as necessary. REFER to Section 307-01B for 4R70W transmissions. REFER to Section 307-01A for 4R100 transmissions.
<ul style="list-style-type: none"> Manual Transmission Clutch throw-out bearing whine. A change in noise pitch or 	<ul style="list-style-type: none"> Worn throw-out bearing. 	<ul style="list-style-type: none"> INSTALL a new throw-out bearing. REFER to Section 308-01.



BUY IT NOW!

Click Here To Order

PayPal

MasterCard

Discover

Novus

MasterCard

VISA

DIAGNOSIS AND TESTING (Continued)**Symptom Chart—Idle Noise/Vibration (Continued)**

Condition	Possible Sources	Action
<ul style="list-style-type: none"> • Heating, vacuum and air conditioning (HVAC) system chirp — most audible inside the vehicle. Listen for a change in noise pitch or loudness while changing the HVAC system blower speed 	<ul style="list-style-type: none"> • Damaged or worn HVAC blower bearing. 	<ul style="list-style-type: none"> • INSTALL a new blower motor. REFER to Section 412-02.
<ul style="list-style-type: none"> • Air conditioning (A/C) clutch ticking — occurs when the compressor clutch engages 	<ul style="list-style-type: none"> • Acceptable noise. • Incorrect air gap. 	<ul style="list-style-type: none"> • LISTEN to the clutch to determine if the noise occurs with clutch engagement. A small amount of noise is acceptable. If the noise is excessive, CHECK the A/C clutch air gap. INSPECT the A/C clutch for wear or damage. INSTALL a new clutch as necessary. REFER to Section 412-03.
<ul style="list-style-type: none"> • Intermittent rattle, or scraping/rubbing noise 	<ul style="list-style-type: none"> • Loose exhaust heat shield(s). • Wiring, hose or other part interfering with accessory drive, drive belt or pulley. 	<ul style="list-style-type: none"> • INSPECT the exhaust system for loose parts using a glove or clamps to verify cause. REPAIR as necessary. REFER to Section 309-00. • INSPECT accessory drive system closely verifying there is adequate clearance to all rotating components. REPAIR as necessary.
<ul style="list-style-type: none"> • Engine ticking or knocking noise — occurs during idle or high idle during the first cold start of the day 	<ul style="list-style-type: none"> • Piston noise or valvetrain noise (bled down lifter/lash adjuster). 	<ul style="list-style-type: none"> • GO to Pinpoint Test G.
<ul style="list-style-type: none"> • A continuous, speed-dependent rattle from the engine — occurs during idle or high idle during the first cold start of the day and disappears as the engine warms up 	<ul style="list-style-type: none"> • Piston noise or valvetrain noise (bled down lifter/lash adjuster). 	<ul style="list-style-type: none"> • GO to Pinpoint Test G.
<ul style="list-style-type: none"> • Idle vibration—a low-frequency vibration (5-20 Hz) or mild shake that is felt through the seat/floorpan 	<ul style="list-style-type: none"> • Cylinder misfire. • Engine or torque converter out of balance. 	<ul style="list-style-type: none"> • Using a scan tool, CHECK the ignition system. CARRY OUT a cylinder power test. REFER to Section 303-00. • VERIFY the torque converter to crankshaft pilot clearance is correct, REPAIR as necessary. RE-INDEX the torque converter on the flex plate by 120° on a 3 bolt converter or 180° for a 4 bolt converter. REFER to Section 307-01B for 4R70W transmissions. REFER to Section 307-01A for 4R100 transmissions. RETEST the vehicle.



BUY IT NOW!

Click Here To Order



DIAGNOSIS AND TESTING (Continued)**Symptom Chart—Idle Noise/Vibration (Continued)**

Condition	Possible Sources	Action
<ul style="list-style-type: none"> Idle vibration—a high-frequency vibration (20-80 Hz) or buzz, that is felt through the steering wheel or seat 	<ul style="list-style-type: none"> Exhaust system mounts bound up. Body mounts loose. Power steering lines grounded out. 	<ul style="list-style-type: none"> VERIFY concern occurs at engine firing frequency. CHECK that the exhaust system vibrates at the same frequency as the engine. ADD 9-14 km (20-30 lb.) to the tail pipe to test. CARRY OUT Exhaust System Neutralizing in this section. INSPECT the body mounts. REPAIR as necessary. INSPECT that the power steering lines are not contacting the chassis or each other. REPAIR as necessary.

Symptom Chart—Squeak and Rattle

Condition	Possible Sources	Action
<ul style="list-style-type: none"> Squeak—heard inside the vehicle when closing/opening the door 	<ul style="list-style-type: none"> Insufficient lubrication on the door hinge or check strap. Internal door components loose, rubbing or misaligned. 	<ul style="list-style-type: none"> LUBRICATE the hinge or check strap. CHECK the inside of the door. TIGHTEN or ALIGN as necessary. USE the Squeak and Rattle Repair Kit to isolate any rubbing components.
<ul style="list-style-type: none"> Squeak—heard inside the vehicle when closing/opening the window 	<ul style="list-style-type: none"> Worn or damaged glass run/channel. 	<ul style="list-style-type: none"> REPAIR or INSTALL a new glass run/channel. REFER to Section 501-11.
<ul style="list-style-type: none"> Squeak—heard outside of vehicle when closing/opening the door 	<ul style="list-style-type: none"> Exhaust shield rubbing against the chassis or exhaust pipe. 	<ul style="list-style-type: none"> CHECK the exhaust system. REPAIR as necessary. Section 309-00.
<ul style="list-style-type: none"> Squeak—occurs with initial brake pedal application 	<ul style="list-style-type: none"> Disc brake pads. 	<ul style="list-style-type: none"> Under certain conditions, asbestos free pads can generate a squeak noise. This noise is normal and does not indicate a concern.
<ul style="list-style-type: none"> Squeak—a constant noise that occurs with brake pedal applications 	<ul style="list-style-type: none"> Damaged or worn disc brake pads. 	<ul style="list-style-type: none"> INSPECT the pads for oil, grease or brake fluid contamination. CHECK for glazed linings. A brake disc with hard spots will also cause a squeak type noise. REPAIR or INSTALL new pads as necessary. REFER to Section 206-03 for front disc brakes or Section 206-04 for rear disc brakes.



BUY IT NOW!
Click Here To Order



DIAGNOSIS AND TESTING (Continued)**Symptom Chart—Squeak and Rattle (Continued)**

Condition	Possible Sources	Action
<ul style="list-style-type: none"> Squeak—noise occurs over bumps or when turning 	<ul style="list-style-type: none"> Worn control arm bushings. Worn or damaged shock absorber/strut. 	<ul style="list-style-type: none"> INSPECT the control arm bushings. Spray with lubricant and CARRY OUT a “bounce test” to determine which bushing. REPAIR as necessary. REFER to Section 204-01A for 2-wheel drive vehicles or Section 204-01B for 4-wheel drive vehicles. INSPECT the shock absorber for damage. CARRY OUT a “bounce test” to isolate the noise. INSTALL a new shock absorber/strut as necessary. REFER to Section 204-01A for 2-wheel drive vehicles and Section 204-01B for 4-wheel drive vehicles front shock absorber/strut or Section 204-02 for the rear shock absorber/strut.
<ul style="list-style-type: none"> Rattle—heard when closing/opening the door or window 	<ul style="list-style-type: none"> Loose internal door mechanism, bracket or attachment. 	<ul style="list-style-type: none"> REPEAT the motion or CARRY OUT a “tap test” to duplicate the noise. INSPECT the door for loose components. TIGHTEN loose components or USE the Rotunda Squeak and Rattle Kit to isolate any rattling components.
<ul style="list-style-type: none"> Squeak or rattle—heard inside the vehicle over rough roads/bumps 	<ul style="list-style-type: none"> Misaligned glove compartment door/hinge. Instrument panel trim loose or misaligned. Loose interior component or trim. 	<ul style="list-style-type: none"> ALIGN the glove compartment door. INSPECT the instrument panel trim for missing or loose clips or screws. REPAIR as necessary. CARRY OUT a “touch test”. ELIMINATE the noise by pressing or pulling on interior trim and components. USE the Rotunda Squeak and Rattle Kit to isolate any rattling/squeaking components.



BUY IT NOW!

Click Here To Order



DIAGNOSIS AND TESTING (Continued)**Symptom Chart—Squeak and Rattle (Continued)**

Condition	Possible Sources	Action
<ul style="list-style-type: none"> Squeak or rattle—noise with a vibration concern 	<ul style="list-style-type: none"> Damaged or worn body mounts. Damaged or worn sub-frame mounts. 	<ul style="list-style-type: none"> INSPECT the upper and lower absorbers and washers for damage or wear. CHECK the body mount brackets for damage. CHECK the nuts and bolts are tightened to specifications. TIGHTEN as necessary. INSPECT the upper and lower absorbers for damage or wear. CHECK the sub-frame for damage. CHECK the nuts and bolts are tightened to specifications. TIGHTEN as necessary.

Symptom Chart—Steering Noise/Vibration

Condition	Possible Sources	Action
<ul style="list-style-type: none"> Steering grunt or shudder — occurs when turning into or out of a turn at low speeds (temperature sensitive) 	<ul style="list-style-type: none"> Steering gear or power steering hoses. 	<ul style="list-style-type: none"> GO to Steering Gear Grunt/Shudder Test component test in this section.
<ul style="list-style-type: none"> Steering System clonk—hydraulic knocking sound 	<ul style="list-style-type: none"> Air in the steering hydraulic system. 	<ul style="list-style-type: none"> CHECK for leaks in the system. PURGE the air from the system. REFER to Section 211-00.
<ul style="list-style-type: none"> Power steering pump moan — loud humming noise occurs when the steering wheel is rotated to the stop position. Produces a 120-600 Hz frequency that changes with rpm 	<ul style="list-style-type: none"> Power steering hose grounded out to chassis. Aerated fluid. Steering gear isolators. Low fluid. Power steering pump brackets loose or misaligned. 	<ul style="list-style-type: none"> INSPECT the power steering hoses. REPAIR as necessary. CHECK for leaks in the system. PURGE the air from the system. REFER to Section 211-00. INSPECT the isolators for wear or damage. REPAIR as necessary. CHECK the fluid level. REFILL as necessary. CHECK bolts, brackets and bracket alignment. TIGHTEN bolts to specification. REPAIR or INSTALL new brackets as necessary. REFER to Section 211-02.
<ul style="list-style-type: none"> Steering gear clunk — occurs only while cornering over a bump (can be temperature sensitive) 	<ul style="list-style-type: none"> Steering gear. 	<ul style="list-style-type: none"> INSPECT the steering gear for loose mounting bolts. TIGHTEN as necessary. REFER to Section 211-02.

**BUY IT NOW!****Click Here To Order**

DIAGNOSIS AND TESTING (Continued)**Symptom Chart—Steering Noise/Vibration (Continued)**

Condition	Possible Sources	Action
<ul style="list-style-type: none"> Feedback (rattle, chuckle or knocking noise in the steering gear) — a condition where roughness is felt in the steering wheel when the vehicle is driven over rough surfaces 	<ul style="list-style-type: none"> Column intermediate/flexible shaft joints damaged or worn. Loose, damaged or worn tie-rod ends. Steering gear insulators or mounting bolts loose or damaged. Steering column intermediate shaft bolts are loose. Steering column damaged or worn. Loose suspension bushings, bolts or ball joints. 	<ul style="list-style-type: none"> INSTALL a new intermediate/flexible shaft. REFER to Section 211-04. TIGHTEN the nuts to specification or INSTALL new tie-rod ends as necessary. REFER to Section 211-03. TIGHTEN the bolts or INSTALL new bolts as necessary. REFER to Section 211-02. TIGHTEN the bolts to specification. REFER to Section 211-04. REPAIR or INSTALL a new steering column as necessary. REFER to Section 211-04. INSPECT the suspension system. TIGHTEN or INSTALL new components as necessary. REFER to Section 204-01A for 2-wheel drive vehicles or Section 204-01B for 4-wheel drive vehicles.
<ul style="list-style-type: none"> Feedback (nibble at the steering wheel) — a condition where slight rotational movement is felt in the steering wheel when the vehicle is driven over rough or grooved surfaces 	<ul style="list-style-type: none"> Lateral runout in the tire or wheel. Yoke spring in the steering gear. 	<ul style="list-style-type: none"> GO to Pinpoint Test H. CHECK TSBs for revised yoke spring for applicable vehicles.
<ul style="list-style-type: none"> Accessory drive belt squeal/chirp—when rotating the steering wheel from stop to stop 	<ul style="list-style-type: none"> Loose or worn accessory drive belt. 	<ul style="list-style-type: none"> ADJUST or INSTALL a new accessory belt as necessary. REFER to Section 303-05.
<ul style="list-style-type: none"> Power steering gear hiss 	<ul style="list-style-type: none"> Steering column intermediate/flexible shaft-to-steering gear is binding or misaligned. Grounded or loose steering column boot at the dash panel. Damaged or worn steering gear input shaft and valve. 	<ul style="list-style-type: none"> REPAIR or INSTALL a new intermediate/flexible shaft as necessary. REFER to Section 211-04. REPAIR as necessary. REPAIR or INSTALL a new steering gear as necessary. REFER to Section 211-02.



BUY IT NOW!

Click Here To Order



DIAGNOSIS AND TESTING (Continued)**Symptom Chart—Steering Noise/Vibration (Continued)**

Condition	Possible Sources	Action
<ul style="list-style-type: none"> Steering column rattle 	<ul style="list-style-type: none"> Loose bolts or attaching brackets. Loose, worn or insufficiently lubricated column bearings. Steering shaft insulators damaged or worn. Intermediate/flexible shaft compressed or extended. 	<ul style="list-style-type: none"> TIGHTEN the bolts to specifications. LUBRICATE or INSTALL new steering column bearings as necessary. REFER to Section 211-04. INSTALL new insulators. REFER to Section 211-04. INSPECT the rubber spider coupling for damage. INSTALL a new intermediate/flexible shaft. REFER to Section 211-04.
<ul style="list-style-type: none"> Steering column squeak or cracks 	<ul style="list-style-type: none"> Insufficient lubricated steering shaft bushings. Loose or misaligned steering column shrouds. Steering wheel rubbing against steering column shrouds. Insufficient lubricated speed control slip ring. Upper or lower bearing sleeve out of position. 	<ul style="list-style-type: none"> LUBRICATE the steering shaft and shaft tube seals. TIGHTEN or ALIGN the steering column shrouds. REPOSITION the steering column shrouds. LUBRICATE the speed control slip ring. REPOSITION the bearing sleeves.
<ul style="list-style-type: none"> Power steering pump noisy 	<ul style="list-style-type: none"> Incorrect assembly of components. Imperfections on the outside diameter or end surface of the power steering pump rotor. Damaged or worn power steering pump rotor splines. A crack on the inner surface of the power steering pump cam. Interference between the power steering pump rotor and cam. Damaged or worn power steering pump rotor and pressure plates. 	<ul style="list-style-type: none"> REPAIR or INSTALL a new power steering pump as necessary. REFER to Section 211-02.
<ul style="list-style-type: none"> Power steering pump swish noise 	<ul style="list-style-type: none"> Power steering fluid flow into the bypass valve of the pump valve housing with fluid temperature below 54°C (130°F). 	<ul style="list-style-type: none"> Acceptable condition.
<ul style="list-style-type: none"> Power steering pump whine noise 	<ul style="list-style-type: none"> Aerated fluid. Damaged power steering pump cam. Damaged valve cover O-ring seal. 	<ul style="list-style-type: none"> CHECK for a leak in the system. PURGE the air from the system. REFER to Section 211-00. REPAIR or INSTALL a new power steering pump as necessary. REFER to Section 211-02. REPAIR or INSTALL a new power steering pump as necessary. REFER to Section 211-02.



BUY IT NOW!

Click Here To Order



DIAGNOSIS AND TESTING (Continued)**Symptom Chart—Steering Noise/Vibration (Continued)**

Condition	Possible Sources	Action
<ul style="list-style-type: none"> Power steering pump clicking (mechanical) noise 	<ul style="list-style-type: none"> Power steering pump rotor slippers too long, excessive rotor slipper-to-slot clearance or damaged or worn rotor assembly. 	<ul style="list-style-type: none"> REPAIR or INSTALL a new power steering pump as necessary. REFER to Section 211-02.
<ul style="list-style-type: none"> Power steering pump clatter noise 	<ul style="list-style-type: none"> Damaged corners on the outside diameter or the power steering rotor or distorted rotor slipper ring. 	<ul style="list-style-type: none"> REPAIR or INSTALL a new power steering pump as necessary. REFER to Section 211-02.

Symptom Chart—Suspension Noise/Vibration

Condition	Possible Sources	Action
<ul style="list-style-type: none"> Squeak or grunt—noise from the front suspension, occurs more in cold ambient temperatures. More noticeable over rough roads or when turning 	<ul style="list-style-type: none"> Front stabilizer bar insulators. 	<ul style="list-style-type: none"> Under these conditions, the noise is acceptable. CHECK TSBs for applicable vehicle.
<ul style="list-style-type: none"> Clunk—noise from the front suspension, occurs in and out of turns 	<ul style="list-style-type: none"> Loose front struts or shocks. 	<ul style="list-style-type: none"> INSPECT for loose nuts or bolts. TIGHTEN to specifications. REFER to Section 204-01A for 2-wheel drive vehicles or Section 204-01B for 4-wheel drive vehicles.
<ul style="list-style-type: none"> Clunk—noise from the rear suspension, occurs when shifting from reverse to drive 	<ul style="list-style-type: none"> Loose rear suspension components. 	<ul style="list-style-type: none"> INSPECT for loose or damaged rear suspension components. REPAIR or INSTALL new components as necessary. REFER to Section 204-02.
<ul style="list-style-type: none"> Click or pop—noise from the front suspension. More noticeable over rough roads or over bumps 	<ul style="list-style-type: none"> Worn or damaged ball joints. 	<ul style="list-style-type: none"> CARRY OUT a ball joint inspection. INSTALL new ball joints or control arms as necessary REFER to Section 204-01A for 2-wheel drive vehicles or Section 204-01B for 4-wheel drive vehicles.
<ul style="list-style-type: none"> Click or pop (FWD vehicles)—noise occurs when vehicle is turning 	<ul style="list-style-type: none"> Worn or damaged ball joints. 	<ul style="list-style-type: none"> CARRY OUT a ball joint inspection. INSTALL new ball joints or control arms as necessary.
<ul style="list-style-type: none"> Click or snap—occurs when accelerating around a corner 	<ul style="list-style-type: none"> Damaged or worn outboard CV joint. 	<ul style="list-style-type: none"> INSPECT the outboard CV joint and boot. REPAIR or INSTALL a new CV joint as necessary. REFER to Section 204-01B.

**BUY IT NOW!****Click Here To Order**

DIAGNOSIS AND TESTING (Continued)**Symptom Chart—Suspension Noise/Vibration (Continued)**

Condition	Possible Sources	Action
<ul style="list-style-type: none"> Front suspension noise—a squeak, creak or rattle noise. Occurs mostly over bumps or rough roads 	<ul style="list-style-type: none"> Steering components. Loose or bent front struts or shock absorbers. Damaged spring or spring mounts. Damaged or worn control/radius arm bushings. Worn or damaged stabilizer bar bushings or links. 	<ul style="list-style-type: none"> GO to Pinpoint Test H.
<ul style="list-style-type: none"> Rear suspension noise—a squeak, creak or rattle noise. Occurs mostly over bumps or rough roads 	<ul style="list-style-type: none"> Loose or bent rear shock absorbers. Damaged spring or spring mounts. Damaged or worn control arm bushings. Worn or damaged stabilizer bar bushings or links. 	<ul style="list-style-type: none"> GO to Pinpoint Test I.
<ul style="list-style-type: none"> Shudder—occurs during acceleration from a slow speed or stop 	<ul style="list-style-type: none"> Rear drive axle assembly mispositioned. Incorrect or high CV joint operating angle. Damaged or worn front suspension components. 	<ul style="list-style-type: none"> CHECK the axle mounts and the rear suspension for damage or wear. REPAIR as necessary. CHECK vehicle ride height is within limits. REPAIR as necessary. CHECK for a loose stabilizer bar, damaged or loose strut/strut bushings or loose or worn ball joints. INSPECT the steering linkage for wear or damage. REPAIR or INSTALL new components as necessary.
<ul style="list-style-type: none"> Shimmy—most noticeable on coast/deceleration. Also hard steering condition 	<ul style="list-style-type: none"> Excessive positive caster. 	<ul style="list-style-type: none"> CHECK the caster alignment angle. CORRECT as necessary. REFER to Section 204-00.

Symptom Chart—Tire Noise/Vibration

Condition	Possible Sources	Action
<ul style="list-style-type: none"> Tire noise—hum/moan at constant speeds 	<ul style="list-style-type: none"> Abnormal wear patterns. 	<ul style="list-style-type: none"> SPIN the tire and CHECK for tire wear. INSTALL new tire(s) as necessary. INSPECT for damaged/worn suspension components. CARRY OUT wheel alignment.
<ul style="list-style-type: none"> Tire noise—noise tone lowers as the vehicle speed is lowered 	<ul style="list-style-type: none"> Out-of-balance tire. 	<ul style="list-style-type: none"> BALANCE the tire and road test. INSTALL a new tire as necessary. REFER to Section 204-04.
<ul style="list-style-type: none"> Tire noise—ticking noise, changes with speed 	<ul style="list-style-type: none"> Nail puncture or stone in tire tread. 	<ul style="list-style-type: none"> INSPECT the tire. REPAIR as necessary.
<ul style="list-style-type: none"> Wheel and tire—vibration and noise concern is directly related to vehicle speed and is not 	<ul style="list-style-type: none"> Damaged or worn tire. 	<ul style="list-style-type: none"> GO to Pinpoint Test J.



BUY IT NOW!

Click Here To Order



DIAGNOSIS AND TESTING (Continued)**Symptom Chart—Tire Noise/Vibration (Continued)**

Condition	Possible Sources	Action
<ul style="list-style-type: none"> Tire wobble or shudder — occurs at lower speeds 	<ul style="list-style-type: none"> Damaged wheel bearings. Damaged wheel. Damaged or worn suspension components. Loose wheel nuts. Damaged or uneven tire wear. 	<ul style="list-style-type: none"> SPIN the tire and CHECK for abnormal wheel bearing play or roughness. ADJUST or INSTALL new wheel bearings as necessary. REFER to Section 204-01A for 2-wheel drive vehicles or Section 204-01B for 4-wheel drive vehicles. INSPECT the wheel for damage. INSTALL a new wheel as necessary. REFER to Section 204-04. INSPECT the suspension components for wear or damage. REPAIR as necessary. CHECK the wheel nuts. TIGHTEN to specification. REFER to Section 204-04. SPIN the tire and CHECK for abnormal tire wear or damage. INSTALL a new tire as necessary. REFER to Section 204-04.
<ul style="list-style-type: none"> Tire shimmy or shake — occurs at lower speeds 	<ul style="list-style-type: none"> Wheel/tire out of balance. Uneven tire wear. Excessive radial runout of wheel or tire. Worn or damaged wheel studs or elongated stud holes. Excessive lateral runout of the wheel or tire. Foreign material between the brake disc and hub or in the brake disc fins. 	<ul style="list-style-type: none"> BALANCE the wheel/tire assembly. CHECK for abnormal tire wear. INSTALL a new tire as necessary. REFER to Section 204-04. CARRY OUT a radial runout test of the wheel and tire. INSTALL a new tire as necessary. REFER to Section 204-04. INSPECT the wheel studs and wheels. INSTALL new components as necessary. REFER to Section 204-01A for 2-wheel drive front wheels, Section 204-01B for 4-wheel drive front wheels and Section 204-02 for all rear wheels. CARRY OUT a lateral runout test of the wheel and tire. CHECK the wheel, tire and hub. REPAIR or INSTALL new components as necessary. CLEAN the mounting surfaces of the brake disc and hub. CHECK the brake disc fins for material.



BUY IT NOW!

Click Here To Order



DIAGNOSIS AND TESTING (Continued)**Symptom Chart—Tire Noise/Vibration (Continued)**

Condition	Possible Sources	Action
<ul style="list-style-type: none"> High speed shake or shimmy—occurs at high speeds 	<ul style="list-style-type: none"> Excessive wheel hub runout. Damaged or worn tires. Damaged or worn wheel bearings. Worn or damaged suspension or steering linkage components. Brake disc or drum imbalance. 	<ul style="list-style-type: none"> GO to Pinpoint Test K.

Symptom Chart—Transmission (Manual) and Transfer Case Noise/Vibration

Condition	Possible Sources	Action
<ul style="list-style-type: none"> Clutch rattling noise—occurs with clutch engaged, noise changes/disappears with clutch pedal depressed 	<ul style="list-style-type: none"> Flywheel bolts, clutch housing bolts or clutch pressure plate bolts loose. 	<ul style="list-style-type: none"> TIGHTEN the bolts to specifications. CHECK the bolts for damage.
<ul style="list-style-type: none"> Clutch squeaking noise—noise is heard when the clutch is operated. Vehicle moves slowly or creeps when the clutch is disengaged. Can also be difficult to shift into first and reverse gear 	<ul style="list-style-type: none"> Pilot bearing seized or damaged. 	<ul style="list-style-type: none"> INSTALL a new pilot bearing. REFER to Section 308-01.
<ul style="list-style-type: none"> Clutch squeaking noise—occurs with clutch pedal depressed/released 	<ul style="list-style-type: none"> Worn clutch pedal shaft or bushings. 	<ul style="list-style-type: none"> INSPECT the clutch pedal for wear or damage. REPAIR as necessary. REFER to Section 308-02.
<ul style="list-style-type: none"> Clutch whirring/rattle noise—occurs when clutch pedal is depressed 	<ul style="list-style-type: none"> Worn, damaged or misaligned clutch release bearing. 	<ul style="list-style-type: none"> INSTALL a new clutch release bearing. REFER to Section 308-01.
<ul style="list-style-type: none"> Clutch grating/grinding noise—occurs when clutch pedal is depressed 	<ul style="list-style-type: none"> Clutch pressure plate fingers bent or worn. Contact surface of clutch release bearing worn or damaged. 	<ul style="list-style-type: none"> INSPECT the clutch pressure plate release fingers. INSTALL a new pressure plate as necessary. REFER to Section 308-01. INSTALL a new clutch release bearing. REFER to Section 308-01.
<ul style="list-style-type: none"> Clutch chatter—a small amount of noise when clutch pedal is released at initial take-off 	<ul style="list-style-type: none"> Clutch engagement. 	<ul style="list-style-type: none"> Acceptable operating condition.



BUY IT NOW!

Click Here To Order



DIAGNOSIS AND TESTING (Continued)**Symptom Chart—Transmission (Manual) and Transfer Case Noise/Vibration (Continued)**

Condition	Possible Sources	Action
<ul style="list-style-type: none"> Clutch chatter/grabs—in some cases a shudder is felt. Occurs with clutch pedal depressed/released 	<ul style="list-style-type: none"> Damaged or worn powertrain/driveline mounts. Binding or dragging plunger of the clutch master cylinder or slave cylinder. Grease or oil on the clutch disc facing. Clutch disc surface glazed or damaged. Damaged or worn clutch pressure plate. Flywheel surface damaged or glazed. 	<ul style="list-style-type: none"> INSPECT the powertrain/drivetrain mounts. REFER to Section 303-01A for 4.2L engines or Section 303-01B for 4.6L and 5.4L engines. INSTALL new mounts as necessary. CHECK the master and slave cylinder operation. INSPECT the components for damage or wear. INSTALL a new master or slave cylinder as necessary. REFER to Section 308-02. CHECK the input shaft seal and rear main oil seal. REPAIR as necessary. INSTALL a new clutch disc. REFER to Section 308-01. INSPECT the clutch disc surface for a glazed, hardened or damage condition. CARRY OUT a disc check. INSTALL a new clutch disc as necessary. REFER to Section 308-01. INSPECT the clutch pressure plate for wear or damage. INSTALL a new clutch pressure plate as necessary. REFER to Section 308-01. INSPECT the flywheel for damage or wear. CARRY OUT a flywheel runout check. INSTALL a new flywheel as necessary. REFER to Section 303-01A for 4.2L engines or Section 303-01B for 4.6L and 5.4L engines.
<ul style="list-style-type: none"> Clutch chatter noise—noise when clutch pedal is released at initial take-off. Clutch is hard to engage and disengage 	<ul style="list-style-type: none"> Pilot bearing worn, damaged or not correctly aligned in bore. 	<ul style="list-style-type: none"> INSPECT the clutch pressure plate release fingers for uneven wear, clutch components burnt or a seized pilot bearing. INSTALL a new pilot bearing as necessary. REFER to Section 308-01.
<ul style="list-style-type: none"> Clutch vibration 	<ul style="list-style-type: none"> Loose flywheel bolts. Damaged or loose clutch pressure plate. Excessive flywheel runout. 	<ul style="list-style-type: none"> GO to Pinpoint Test L.



BUY IT NOW!

Click Here To Order



DIAGNOSIS AND TESTING (Continued)**Symptom Chart—Transmission (Manual) and Transfer Case Noise/Vibration (Continued)**

Condition	Possible Sources	Action
<ul style="list-style-type: none"> Transmission rattling/clattering noise—noise at idle or on light acceleration from a stop. Gear selection difficult 	<ul style="list-style-type: none"> Gearshift lever joint worn or damaged. Gearshift lever loose. Gearshift linkage rods worn or damaged. 	<ul style="list-style-type: none"> INSTALL a new gearshift lever. REFER to Section 308-03. TIGHTEN the bolts to specification. REFER to Section 308-03. CHECK the linkage bushings for wear. INSTALL new linkage rods as necessary.
<ul style="list-style-type: none"> Transmission rattling/clattering noise—occurs in neutral or in gear, at idle 	<ul style="list-style-type: none"> Incorrect fluid level or fluid quality. 	<ul style="list-style-type: none"> CHECK that the transmission is filled to the correct level and with the specified fluid. REFER to Section 308-00.
<ul style="list-style-type: none"> Transmission rattling/clattering noise—noise at idle in neutral 	<ul style="list-style-type: none"> Worn or rough reverse idler gear. Rough running engine, cylinder misfire. Excessive backlash in gears. Worn countershaft gears. 	<ul style="list-style-type: none"> CHECK the reverse idler gear. REPAIR as necessary. REFER to Section 308-03. CHECK the ignition system. CARRY OUT a cylinder power test. REFER to Section 303-00. CHECK the gear backlash. ADJUST as necessary. REFER to Section 308-03. REPAIR as necessary. REFER to Section 308-03.
<ul style="list-style-type: none"> Transmission whine—a mild whine at extreme speeds or high rpm 	<ul style="list-style-type: none"> Rotating gears/geartrain. 	<ul style="list-style-type: none"> Acceptable noise.
<ul style="list-style-type: none"> Transmission whine—a high pitched whine, also described as a squeal 	<ul style="list-style-type: none"> Transmission gears are worn (high mileage vehicle). Mismatched gear sets. Damaged or worn transmission bearing. 	<ul style="list-style-type: none"> Result of normal gear wear. REPAIR as necessary. REFER to Section 308-03. INSPECT the gear sets for an uneven wear pattern on the face of the gear teeth. REPAIR as necessary. REFER to Section 308-00. INSPECT the transmission bearings. INSTALL new bearings as necessary. REFER to the Section 308-03.
<ul style="list-style-type: none"> Transmission growling/humming—noise occurs in the forward gears. The noise is more prominent when the gear is loaded. The problem gear can be located as the noise occurs in a specific gear position 	<ul style="list-style-type: none"> Gear is cracked, chipped or rough. 	<ul style="list-style-type: none"> INSPECT the transmission gears for damage or wear. INSTALL new gears as necessary. REFER to Section 308-03.
<ul style="list-style-type: none"> Transmission hissing—noise in neutral or in forward gears. As bearings wear or break up, the noise changes to a thumping 	<ul style="list-style-type: none"> Damaged or worn bearings. 	<ul style="list-style-type: none"> INSPECT the transmission bearings. INSTALL new bearings as necessary. REFER to Section 308-03.



BUY IT NOW!

Click Here To Order



DIAGNOSIS AND TESTING (Continued)**Symptom Chart—Transmission (Manual) and Transfer Case Noise/Vibration (Continued)**

Condition	Possible Sources	Action
<ul style="list-style-type: none"> Transmission knocking/thudding—noise at low speeds in forward gears 	<ul style="list-style-type: none"> Bearings with damaged balls or rollers or with pitted and spalled races. 	<ul style="list-style-type: none"> INSPECT the transmission bearings. INSTALL new bearings as necessary. REFER to Section 308-03.
<ul style="list-style-type: none"> Transmission rumble/growl—noise at higher speeds in forward gears, more pronounced in a coast/deceleration condition 	<ul style="list-style-type: none"> Incorrect driveline angle. Driveshaft out of balance or damaged. 	<ul style="list-style-type: none"> CHECK the driveline angle. REPAIR as necessary. REFER to Section 205-00. CHECK the driveshaft for damage, missing balance weights or undercoating. Using the electronic vibration analyzer (EVA), CHECK the driveshaft balance. CARRY OUT a driveline vibration test. For additional information, REFER to Section 205-00. REPAIR as necessary.
<ul style="list-style-type: none"> Transmission rumble/growl—noise at all speeds in forward gears, more pronounced in a heavy acceleration condition 	<ul style="list-style-type: none"> Damaged or worn transmission bearing or gears (high mileage vehicles). 	<ul style="list-style-type: none"> CHECK transmission fluid for excessive metal particles. REPAIR as necessary. REFER to Section 308-03.
<ul style="list-style-type: none"> Transfer case whine—noise at all ranges 	<ul style="list-style-type: none"> Incorrect fluid level or fluid quality. Worn oil pump. Under-inflated or oversized tires. 	<ul style="list-style-type: none"> CHECK that the transfer case is filled to the correct level and with the specified fluid. REFER to Section 308-07B. DISASSEMBLE the transfer case. CHECK the oil pump for wear or damage. REPAIR as necessary. REFER to Section 308-07B. CONFIRM that the tires and wheels are correct for the vehicle. CHECK that the tire inflation pressures are correct.
<ul style="list-style-type: none"> Transfer case growl/rumble—noise at all ranges (A small amount of planetary noise can be heard when the transfer case is operated in low range.) 	<ul style="list-style-type: none"> Damaged or worn bearings or planetary gear. 	<ul style="list-style-type: none"> DISASSEMBLE the transfer case. CHECK the bearings or planetary gear for wear or damage. REPAIR as necessary. REFER to Section 308-07B.
<ul style="list-style-type: none"> Transfer case scraping/grating—noise at all ranges 	<ul style="list-style-type: none"> Excessively stretched drive chain hitting the case. 	<ul style="list-style-type: none"> DISASSEMBLE the transfer case. CHECK the drive chain for wear or damage. REPAIR as necessary. REFER to Section 308-07B.
<ul style="list-style-type: none"> Transfer case howl/hum—noise at all ranges or high range only 	<ul style="list-style-type: none"> Worn or damaged sun (input) gear, clutch pack (intermediate) gear or output shaft gear. 	<ul style="list-style-type: none"> DISASSEMBLE the transfer case. CHECK the gears for wear or damage. REPAIR as necessary. REFER to Section 308-07B.



BUY IT NOW!

Click Here To Order



DIAGNOSIS AND TESTING (Continued)**Symptom Chart—Transmission (Manual) and Transfer Case Noise/Vibration (Continued)**

Condition	Possible Sources	Action
<ul style="list-style-type: none"> Transfer case howl/hum—noise at low range only 	<ul style="list-style-type: none"> Worn or damaged intermediate gear and sliding gears (clutch pack). 	<ul style="list-style-type: none"> DISASSEMBLE the transfer case. CHECK the gears for wear or damage. REPAIR as necessary. REFER to Section 308-07B.
<ul style="list-style-type: none"> Transfer case vibration—vibration felt with vehicle in 4WD 	<ul style="list-style-type: none"> Transfer case mounting. Driveshaft out of balance. Excessive pinion flange runout. 	<ul style="list-style-type: none"> GO to Pinpoint Test M.

Symptom Chart—Transmission (Automatic) Noise/Vibration

Condition	Possible Sources	Action
<ul style="list-style-type: none"> Rattle—occurs at idle or at light acceleration from a stop 	<ul style="list-style-type: none"> Damaged engine or transmission mounts. A loose front pipe heat shield. Loose inspection plate or dust cover plate. Loose flexplate to converter nuts. 	<ul style="list-style-type: none"> CHECK the powertrain/drivetrain mounts for damage. CARRY OUT Powertrain/Drivetrain Mount Neutralizing in this section. REPAIR or INSTALL a new heat shield as necessary. CHECK for loose bolts. TIGHTEN to specifications. REFER to Section 307-01B for 4R70W transmissions or Section 307-01A for 4R100 transmissions. CHECK for loose nuts. TIGHTEN to specifications. REFER to Section 307-01B for 4R70W transmissions or Section 307-01A for 4R100 transmissions.
<ul style="list-style-type: none"> Whine—pitch increases with vehicle speed. Starts in first and second gear, decreases or goes away at higher gears 	<ul style="list-style-type: none"> Damaged or worn low one-way clutch. Damaged or worn intermediate one-way clutch. Friction elements. Damaged or worn planetary or sun gear. 	<ul style="list-style-type: none"> INSPECT the transmission for wear or damage. REPAIR or INSTALL new components as necessary. REFER to Section 307-01B for 4R70W transmissions or Section 307-01A for 4R100 transmissions.

**BUY IT NOW!****Click Here To Order**

DIAGNOSIS AND TESTING (Continued)**Symptom Chart—Transmission (Automatic) Noise/Vibration (Continued)**

Condition	Possible Sources	Action
<ul style="list-style-type: none"> Whine—the pitch changes with engine speed 	<ul style="list-style-type: none"> A worn or damaged accessory drive component. Incorrect fluid level. Partially blocked filter. Worn or damaged torque converter. Worn or damaged front pump. 	<ul style="list-style-type: none"> CARRY OUT the Engine Accessory Test. REPAIR or INSTALL new components as necessary. CHECK that the transmission is filled to the correct level. ADD fluid as necessary. REFER to Section 307-01B for 4R70W transmissions or Section 307-01A for 4R100 transmissions. INSPECT the filter. CLEAN or INSTALL a new filter as necessary. REFER to Section 307-01B for 4R70W transmissions or Section 307-01A for 4R100 transmissions. CARRY OUT the torque converter service and replacement check. REFER to Section 307-01B for 4R70W transmissions or Section 307-01A for 4R100 transmissions. INSPECT the front pump. INSTALL a new front pump as necessary. REFER to Section 307-01B for 4R70W transmissions or Section 307-01A for 4R100 transmissions.
<ul style="list-style-type: none"> Whine—pitch changes with vehicle speed 	<ul style="list-style-type: none"> Speedometer cable or gears. 	<ul style="list-style-type: none"> REPAIR or INSTALL new cables or gears as necessary.



BUY IT NOW!

Click Here To Order



PayPal



DIAGNOSIS AND TESTING (Continued)**Symptom Chart—Transmission (Automatic) Noise/Vibration (Continued)**

Condition	Possible Sources	Action
<ul style="list-style-type: none"> Whine/moan type noise—pitch increases or changes with vehicle speed 	<ul style="list-style-type: none"> Damaged engine or transmission mount. U-joints worn or damaged. Damaged or worn differential ring and pinion. Planetary gears nicked or chipped. 	<ul style="list-style-type: none"> CHECK the powertrain/drivetrain mounts for damage. CARRY OUT Powertrain/Drivetrain Mount Neutralizing in this section. INSPECT the U-joints for wear or damage. INSTALL new U-joints as necessary. REFER to Section 205-01. INSPECT the differential ring and pinion for damage. CARRY OUT the Checking Tooth Contact Pattern and Condition of the Ring and Pinion component test in this section. REPAIR or INSTALL a new differential ring and pinion as necessary. REFER to Section 205-02A for Ford 8.8 rear axles, Section 205-02B for Ford 9.75 rear axles, Section 205-02C for Ford 10.25 rear axles or Section 205-03 for front axles. CHECK the planetary gears for damage. INSTALL new components as necessary. REFER to Section 307-01B for 4R70W transmissions or Section 307-01A for 4R100 transmissions.
<ul style="list-style-type: none"> Whistle—noise is high pitched, constant. Changes in pitch with throttle position 	<ul style="list-style-type: none"> Hydraulic pressure in the main control. Incorrect band/clutch apply pressure. Worn or damaged torque converter. 	<ul style="list-style-type: none"> INSPECT the main control. REPAIR or INSTALL new components as necessary. REFER to Section 307-01B for 4R70W transmissions or Section 307-01A for 4R100 transmissions. CARRY OUT the line pressure tests. REPAIR or INSTALL components as necessary. REFER to Section 307-01B for 4R70W transmissions or Section 307-01A for 4R100 transmissions. CARRY OUT the torque converter service and replacement check. REFER to Section 307-01B for 4R70W transmissions or Section 307-01A for 4R100 transmissions.



BUY IT NOW!
Click Here To Order



DIAGNOSIS AND TESTING (Continued)**Symptom Chart—Transmission (Automatic) Noise/Vibration (Continued)**

Condition	Possible Sources	Action
<ul style="list-style-type: none"> • Clunk—occurs when shifting from PARK to a drive or reverse position 	<ul style="list-style-type: none"> • Damaged powertrain mounts. • Damaged or worn pinion bearings. • Worn or galled driveshaft slip yoke splines. • Worn friction elements or excessive clutch pack end plate play. 	<ul style="list-style-type: none"> • INSPECT the powertrain mounts for damage. INSTALL new mounts as necessary. REFER to Section 307-01B for 4R70W transmissions or Section 307-01A for 4R100 transmissions. • CHECK for abnormal bearing play or roughness. INSTALL new bearings as necessary. REFER to Section 205-02A for Ford 8.8 rear axles, Section 205-02B for Ford 9.75 rear axles, Section 205-02C for Ford 10.25 rear axles or Section 205-03 for front axles. • CLEAN and INSPECT the splines of the yoke. INSTALL a new slip yoke as necessary. REFER to Section 205-01. • INSPECT the transmission for wear. CHECK that all end play and clearances are within specification. REPAIR or INSTALL new components as necessary. REFER to Section 307-01B for 4R70W transmissions or Section 307-01A for 4R100 transmissions.
<ul style="list-style-type: none"> • Bump—occurs when shifting from PARK to a drive or reverse position. Similar to Clunk but with no sound 	<ul style="list-style-type: none"> • Initial gear engagement. 	<ul style="list-style-type: none"> • Acceptable condition.
<ul style="list-style-type: none"> • Buzz or hiss 	<ul style="list-style-type: none"> • Incorrect driveline angles. • Worn or damaged main control solenoids or valves. 	<ul style="list-style-type: none"> • CHECK for correct driveline angles. REPAIR as necessary. REFER to Section 205-00. • Using a transmission tester, ACTIVATE the solenoids to duplicate sound. INSTALL new components as necessary. REFER to Section 307-01B for 4R70W transmissions or Section 307-01A for 4R100 transmissions.



BUY IT NOW!

Click Here To Order

PayPal

Discover
Cards

Discover
NEWUS

MasterCard

VISA

DIAGNOSIS AND TESTING (Continued)**Symptom Chart—Transmission (Automatic) Noise/Vibration (Continued)**

Condition	Possible Sources	Action
<ul style="list-style-type: none"> Vibration—a high frequency (20-80 Hz) that is felt through the seat or gear shifter. Changes with engine speed 	<ul style="list-style-type: none"> Transmission cooler lines grounded out. Flexplate to torque converter nuts loose. Fluid filler tube grounded out. Shift cable incorrectly routed, grounded out or loose. 	<ul style="list-style-type: none"> CHECK the transmission cooler lines. REPAIR as necessary. CHECK the flexplate. TIGHTEN to specification. REFER to Section 307-01B for 4R70W transmissions or Section 307-01A for 4R100 transmissions. CHECK the fluid filler tube. REPAIR as necessary. CHECK the shift cable. REPAIR as necessary. REFER to Section 307-05.
<ul style="list-style-type: none"> Shutter or chatter—occurs with light to medium acceleration from low speeds or a stop 	<ul style="list-style-type: none"> Electrical inputs/outputs. Vehicle wiring harness. Incorrect inputs/outputs from the powertrain control module (PCM), digital transmission range (TR) sensor, brake pedal position (BPP) sensor, throttle position (TP) sensor, transmission speed sensor (TSS), output speed shaft (OSS) sensor or the torque converter clutch (TCC). 	<ul style="list-style-type: none"> CARRY OUT a Torque Converter Clutch Operation Test. RUN on-board diagnostics or self-test. REFER to Section 307-01A for 4R100 transmissions or Section 307-01B for 4R70W transmissions. CLEAR the DTC's, road test and rerun on-board diagnostics or self-test.

Pinpoint Tests

The pinpoint tests are a step-by-step diagnostic process designed to determine the cause of a condition. It may not always be necessary to follow a pinpoint test to its conclusion. Carry out only the steps necessary to correct the condition. Then, test the system for normal operation. Sometimes, it is necessary to remove various vehicle components to gain access to the component requiring testing. For additional information, refer to the appropriate section for removal and installation procedures. Reinstall all components after verifying system operation is normal.

PINPOINT TEST A: BRAKE VIBRATION/SHUDDER

CONDITIONS	DETAILS/RESULTS/ACTIONS
A1 ROAD TEST THE VEHICLE—LIGHT BRAKING	<ol style="list-style-type: none"> Check that the wheel and tires are correct for the vehicle. Inspect the tires for abnormal wear patterns.

(Continued)



DIAGNOSIS AND TESTING (Continued)**PINPOINT TEST A: BRAKE VIBRATION/SHUDDER (Continued)**

CONDITIONS	DETAILS/RESULTS/ACTIONS
A1 ROAD TEST THE VEHICLE—LIGHT BRAKING (Continued)	<p data-bbox="831 292 1513 443">2 Road test the vehicle. Warm the brakes by slowing the vehicle a few times from 80-32 km/h (50 to 20 mph) using light braking applications. At highway speeds of 89-97 km/h (55-60 mph), apply the brake using a light pedal force.</p> <ul data-bbox="895 472 1490 530" style="list-style-type: none"> • Is there a vibration/shudder felt in the steering wheel, seat or brake pedal? <p data-bbox="895 557 1082 615">→ Yes GO to A4.</p> <p data-bbox="895 644 1082 702">→ No GO to A2.</p>
A2 ROAD TEST THE VEHICLE—MODERATE TO HEAVY BRAKING	<p data-bbox="831 783 1490 876">1 Road test the vehicle. At highway speeds of 89-97 km/h (55-60 mph), apply the brake using a moderate to heavy pedal force.</p> <ul data-bbox="895 903 1278 932" style="list-style-type: none"> • Is there a vibration/shudder? <p data-bbox="895 961 1362 1019">→ Yes For vehicles with ABS, GO to A3.</p> <p data-bbox="887 1046 1426 1075">For vehicles with standard brakes, GO to A4.</p> <p data-bbox="895 1104 1426 1218">→ No Vehicle is OK. VERIFY condition with customer. TEST the vehicle for normal operation.</p>
A3 NORMAL ACTUATION OF THE ABS SYSTEM DIAGNOSIS	<p data-bbox="831 1301 1490 1591">1 During moderate to heavy braking, noise from the hydraulic control unit (HCU) and pulsation in the brake pedal can be observed. Pedal pulsation coupled with noise during heavy braking or on loose gravel, bumps, wet or snowy surfaces is acceptable and indicates correct functioning of the ABS system. Pedal pulsation or steering wheel nibble (frequency is proportioned to the vehicle speed) indicates a concern with a brake or suspension component.</p> <ul data-bbox="895 1620 1385 1678" style="list-style-type: none"> • Is the vibration/shudder vehicle speed sensitive? <p data-bbox="895 1707 1082 1765">→ Yes GO to A5.</p> <p data-bbox="895 1794 1426 1852">→ No The brake system is operating correctly.</p>

(Continued)

**BUY IT NOW!****Click Here To Order**

DIAGNOSIS AND TESTING (Continued)**PINPOINT TEST A: BRAKE VIBRATION/SHUDDER (Continued)**

CONDITIONS	DETAILS/RESULTS/ACTIONS
A4 APPLICATION OF THE PARKING BRAKE	<p>1 NOTE: Begin at the front of the vehicle unless the vibration or shudder has been isolated to the rear.</p> <p>This test is not applicable to vehicles with drum-in-hat type parking brakes. For vehicles with drum-in-hat parking brakes, proceed to the next test. For all other vehicles, apply the parking brake to identify if the problem is in the front or rear brake. At highway speeds of 89-97 km/h (55-60 mph), lightly apply the parking brake until the vehicle slows down. Release the parking brake immediately after the test.</p> <ul style="list-style-type: none"> • Is there a vibration/shudder? <p>→ Yes GO to A8.</p> <p>→ No GO to A5.</p>
A5 CHECK THE FRONT WHEEL BEARINGS	<p>1 Check the front wheel bearings. Refer to Wheel Bearing Check in this section.</p> <ul style="list-style-type: none"> • Are the wheel bearings OK? <p>→ Yes GO to A6.</p> <p>→ No INSPECT the wheel bearings. ADJUST or REPAIR as necessary. TEST the system for normal operation.</p>

(Continued)



BUY IT NOW!

Click Here To Order 







DIAGNOSIS AND TESTING (Continued)

PINPOINT TEST A: BRAKE VIBRATION/SHUDDER (Continued)

CONDITIONS	DETAILS/RESULTS/ACTIONS
<p>A6 CHECK THE FRONT SUSPENSION</p>	<p>1 Check the front suspension for:</p> <ul style="list-style-type: none"> • Broken or loose bolts. • Damaged springs. • Worn or damaged upper and lower control arm bushings. • Loose or rough front bearings. • Uneven tire wear. <p>• Are all the suspension components in satisfactory condition?</p> <p>→ Yes GO to A7.</p> <p>→ No REPAIR or INSTALL new components as necessary. TEST the system for normal operation.</p>
<p>A7 RESURFACE THE FRONT BRAKE DISCS</p>	<p>1  CAUTION: Do not use a bench lathe to machine brake discs.</p> <p>NOTE: Follow the manufacturer's instructions to machine the brake discs. After machining, make sure the brake disc meets the thickness specification.</p> <p>Resurface the front brake discs or drums. Refer to Brake Disc Machining in this section. Road test the vehicle.</p> <ul style="list-style-type: none"> • Is the vibration/shudder present? <p>→ Yes GO to A8.</p> <p>→ No Vehicle is OK.</p>

(Continued)



BUY IT NOW!

Click Here To Order 



DIAGNOSIS AND TESTING (Continued)**PINPOINT TEST A: BRAKE VIBRATION/SHUDDER (Continued)**

CONDITIONS	DETAILS/RESULTS/ACTIONS
A8 CHECK THE REAR SUSPENSION	<p>1 Check the rear suspension for:</p> <ul style="list-style-type: none"> • Broken or loose bolts. • Damaged or worn springs or spring bushings. • Worn or damaged upper and lower control arm bushings. • Worn or damaged trailing arms. • Loose or rough rear bearings. • Uneven tire wear. <p>• Are all the suspension components in satisfactory condition?</p> <p>→ Yes GO to A9.</p> <p>→ No REPAIR or INSTALL new components as necessary. TEST the system for normal operation.</p>
A9 RESURFACE THE REAR BRAKE DISC OR DRUM	<p>1  CAUTION: Do not use a bench lathe to machine brake discs.</p> <p>NOTE: Follow the manufacturer's instructions to machine the brake discs. After machining, make sure the brake disc meets the thickness specification.</p> <p>Resurface the front brake discs. Refer to Brake Disc Machining in this section. Road test the vehicle.</p> <ul style="list-style-type: none"> • Is the vibration/shudder present? <p>→ Yes CHECK the front suspension for wear or damage. RESURFACE the front brake discs. TEST the system for normal operation.</p> <p>→ No Vehicle is OK.</p>



BUY IT NOW!

Click Here To Order



DIAGNOSIS AND TESTING (Continued)

PINPOINT TEST B: ENGINE TICKING NOISE

CONDITIONS	DETAILS/RESULTS/ACTIONS
B1 CHECK FOR TICKING NOISE AT THE FUEL RAIL	
	<p>1 Disconnect the first fuel line clip.</p> <ul style="list-style-type: none"> • Is the ticking noise gone? → Yes CHECK for TSB for applicable vehicle. REPAIR as necessary. TEST the system for normal operation. → No GO to B2.
B2 CHECK FOR TICKING NOISE AT THE FUEL INJECTOR	
	<p>1 Using an EngineEAR, listen at the fuel injectors by placing a probe on each injector. To isolate the faulty injector, disconnect the injector electrical connector and listen for the noise.</p> <ul style="list-style-type: none"> • Is the fuel injector the source of the ticking noise? → Yes INSTALL a new fuel injector. REFER to Section 303-04A for 4.2L engines or Section 303-04B for 4.6L and 5.4L engines. TEST the system for normal operation. → No GO to B3.
B3 CHECK THE BELT TENSIONER FOR TICKING NOISE	
	<p>1 Inspect the accessory drive. Check for the belt tensioner bottoming at end of travel or not at end of stroke.</p> <p>2 Using an EngineEAR, listen at the belt tensioner.</p> <ul style="list-style-type: none"> • Is the belt tensioner the source of the noise? → Yes INSTALL a new belt tensioner. TEST the system for normal operation. → No GO to B4.

(Continued)



BUY IT NOW!
Click Here To Order



DIAGNOSIS AND TESTING (Continued)

PINPOINT TEST B: ENGINE TICKING NOISE (Continued)

CONDITIONS	DETAILS/RESULTS/ACTIONS
B4 CHECK THE WATER PUMP FOR TICKING NOISE	<p>1 Using an EngineEAR, listen at the water pump for ticking noise.</p> <ul style="list-style-type: none"> • Is the water pump the source of the noise? <p>→ Yes INSTALL a new water pump. REFER to Section 303-03A for standard cooling or Section 303-03B for supercharger cooling. TEST the system for normal operation.</p> <p>→ No GO to B5.</p>
B5 CHECK FOR AN OBSTRUCTION OF THE COOLING FAN	<p>1 Inspect the cooling fan for obstructions.</p> <p>2 Check the cooling fan and shroud for wear or damage.</p> <ul style="list-style-type: none"> • Was there an obstruction or does the cooling fan show signs of damage? <p>→ Yes REPAIR or INSTALL a new cooling fan. REFER to Section 303-03A for standard cooling or Section 303-03B for supercharger cooling. TEST the system for normal operation.</p> <p>→ No GO to B6.</p>
B6 CHECK THE OIL PUMP FOR TICKING NOISE	<p>1 Check the oil pump using EngineEARs and probe at the oil filter adapter to verify the oil pump as a source.</p> <ul style="list-style-type: none"> • Is the oil pump the source of the noise? <p>→ Yes INSTALL a new oil pump. REFER to Section 303-01A for 4.2L engines or Section 303-01B for 4.6L and 5.4L engines. TEST the system for normal operation.</p> <p>→ No GO to B7.</p>

(Continued)

100% SATISFACTION GUARANTEED

BUY IT NOW!

Click Here To Order



PayPal Discover MasterCard VISA

DIAGNOSIS AND TESTING (Continued)

PINPOINT TEST B: ENGINE TICKING NOISE (Continued)

CONDITIONS	DETAILS/RESULTS/ACTIONS
B7 CHECK VALVE LIFTERS OR LASH ADJUSTERS FOR CORRECT OPERATION	
	<p>1 Check valve lifter/lash adjuster for correct operation, using EngineEARS.</p> <ul style="list-style-type: none"> • Are the valve lifters/lash adjusters operating correctly? → Yes VERIFY customer concern. CONDUCT a diagnosis of other suspect components. → No INSTALL a new valve lifter/lash adjuster(s). TEST the system for normal operation.

PINPOINT TEST C: ACCESSORY DRIVE BEARING HOOT

CONDITIONS	DETAILS/RESULTS/ACTIONS
C1 CHECK THE ACCESSORY DRIVE IDLER AND TENSIONER PULLEY BEARINGS	
<p style="text-align: center;">2</p>  <p style="text-align: center;">4</p> 	<p>1 Carry out the Vehicle Cold Soak Procedure in this section.</p> <p>3 Place an EngineEAR probe directly on the pulley center post or bolt to verify which bearing is making the noise.</p> <ul style="list-style-type: none"> • Is either bearing making the noise? → Yes INSTALL a new pulley/idler. CARRY OUT the Vehicle Cold Soak Procedure and TEST the system for normal operation. → No CONDUCT a diagnosis on other suspect accessory drive components.







BUY IT NOW!

Click Here To Order



DIAGNOSIS AND TESTING (Continued)

PINPOINT TEST D: POWER STEERING MOAN

CONDITIONS	DETAILS/RESULTS/ACTIONS
<p>D1 CHECK THE POWER STEERING SYSTEM</p> <div style="text-align: center;">  <p>2</p>  <p>4</p> </div>	<p>1 Carry out the Vehicle Cold Soak Procedure in this section.</p> <p>3 Turn the steering wheel while the noise is occurring and listen for changes in sound pitch or loudness.</p> <ul style="list-style-type: none"> • Does the sound pitch or loudness change while turning the steering wheel? <p>→ Yes GO to D2.</p> <p>→ No CONDUCT a diagnosis on other suspect accessory drive components.</p>
<p>D2 VERIFY THE SOURCE</p> <div style="text-align: center;">  <p>1</p>  <p>3</p> </div>	<p>2 Place an EngineEAR probe near the power steering pump/reservoir while the noise is occurring. While an assistant turns the steering wheel, listen for changes in sound pitch or loudness.</p>

(Continued)



BUY IT NOW!

Click Here To Order





DIAGNOSIS AND TESTING (Continued)

PINPOINT TEST D: POWER STEERING MOAN (Continued)

CONDITIONS	DETAILS/RESULTS/ACTIONS
D2 VERIFY THE SOURCE (Continued)	
	<ul style="list-style-type: none"> • Does the sound pitch or loudness change while turning the steering wheel? → Yes VERIFY that the supply tube to the pump is unobstructed. CHECK the fluid condition and level. DRAIN the fluid and REFILL. REFER to Section 211-02. CARRY OUT the Vehicle Cold Soak Procedure and TEST the system for normal operation. → No Normal system operation.

PINPOINT TEST E: ENGINE DRIVEN COOLING FAN MOAN

CONDITIONS	DETAILS/RESULTS/ACTIONS
E1 CHECK THE ENGINE DRIVEN COOLING FAN AFTER A COLD SOAK	
 	<ol style="list-style-type: none"> 1 Carry out the Vehicle Cold Soak Procedure in this section. 3 Assess the airflow. 4 Raise the engine speed to 1500 rpm while listening for the moan to increase in proportion to the airflow. <ul style="list-style-type: none"> • Does the moan increase in proportion to the airflow? → Yes TEST the fan for normal operation. If the fan tests normal, GO to E2. Otherwise, REPAIR as necessary. → No Normal system operation.

(Continued)



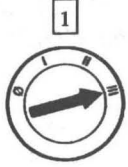
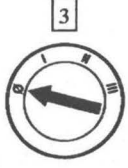

DIAGNOSIS AND TESTING (Continued)

PINPOINT TEST E: ENGINE DRIVEN COOLING FAN MOAN (Continued)

CONDITIONS	DETAILS/RESULTS/ACTIONS
<p>E2 CHECK THE ENGINE DRIVEN COOLING FAN AT NORMAL OPERATING TEMPERATURE</p> <div style="text-align: center;">  <p>1</p> </div> <div style="text-align: center;">  <p>3</p> </div>	<p>2 Run the engine to normal operating temperature while listening for the moan to stop.</p> <ul style="list-style-type: none"> • Does the moan stop? → Yes Normal clutch operation. → No INSTALL a new fan clutch. TEST the system for normal operation.

PINPOINT TEST F: DRUMMING NOISE

CONDITIONS	DETAILS/RESULTS/ACTIONS
<p>F1 CHECK THE EXHAUST SYSTEM</p> <div style="text-align: center;">  <p>1</p> </div> <div style="text-align: center;">  <p>3</p> </div>	<p>2 Increase the engine rpm until the noise is the loudest. Note the engine rpm.</p>

(Continued)



100% SATISFACTION GUARANTEED

BUY IT NOW!

Click Here To Order

DIAGNOSIS AND TESTING (Continued)

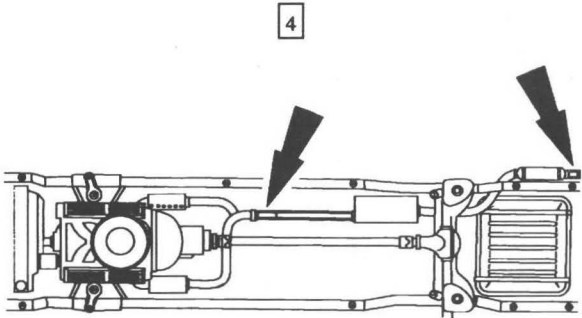
PINPOINT TEST F: DRUMMING NOISE (Continued)

CONDITIONS	DETAILS/RESULTS/ACTIONS
<p>F1 CHECK THE EXHAUST SYSTEM (Continued)</p>  <p>DF1768-A</p>  	<p>4 Add approximately 9 kg (20 lb) of weight to the exhaust system. First place the weight at the tail pipe and test, then place it at the front pipe.</p> <p>6 Increase the engine rpm and listen for the drumming noise. Note the engine rpm if the noise occurs.</p> <p>8 Using an electronic vibration analyzer (EVA), determine the amount of vibration that occurs with the drumming noise.</p> <ul style="list-style-type: none"> • Is the noise/vibration reduced or eliminated, or does the noise/vibration occur at a different rpm? <p>→ Yes CARRY OUT Exhaust System Neutralizing in this section. TEST the system for normal operation.</p> <p>→ No GO to F2.</p>

(Continued)



BUY IT NOW!

Click Here To Order





DIAGNOSIS AND TESTING (Continued)

PINPOINT TEST F: DRUMMING NOISE (Continued)

CONDITIONS	DETAILS/RESULTS/ACTIONS
<p>F2 POWERTRAIN/DRIVETRAIN MOUNT NEUTRALIZING</p>	<p>1 Carry out Powertrain/Drivetrain Mount Neutralizing in this section. Test the system for normal operation.</p> <ul style="list-style-type: none"> • Is the noise reduced or eliminated? → Yes Vehicle OK. TEST the system for normal operation. → No CONDUCT diagnosis of other suspect components.

PINPOINT TEST G: ENGINE TICKING, KNOCKING OR CONTINUOUS RATTLE

CONDITIONS	DETAILS/RESULTS/ACTIONS
<p>G1 CHECK FOR NOISE AT THE VALVE COVERS AND THE FRONT COVERS (OHC ENGINES)</p> <div style="text-align: center;"> <p>2</p>  </div> <div style="text-align: center;"> <p>4</p>  </div>	<p>1 Carry out the Vehicle Cold Soak Procedure in this section.</p> <p>3 NOTE: For a short-duration ticking noise, multiple engine starts may be necessary. Using an EngineEAR, listen closely at the valve covers and the front covers (OHC engines) by placing the probe near the surface of the valve cover and then on the surface front cover.</p> <ul style="list-style-type: none"> • Is the noise source apparent? → Yes REMOVE the appropriate cover and INSPECT for loose, worn/broken components. REPAIR as necessary. TEST the system for normal operation. → No GO to G2.

100% SATISFACTION GUARANTEED

BUY IT NOW!





Click Here To Order



(Continued)

DIAGNOSIS AND TESTING (Continued)

PINPOINT TEST G: ENGINE TICKING, KNOCKING OR CONTINUOUS RATTLE (Continued)

CONDITIONS	DETAILS/RESULTS/ACTIONS
G2 CHECK FOR NOISE AT THE CYLINDER BLOCK	
<div style="text-align: center;"> <p>1</p>  </div> <div style="text-align: center;"> <p>3</p>  </div>	<p>2 Using an EngineEAR, listen closely at the cylinder block by placing a probe on or near each freeze plug.</p> <ul style="list-style-type: none"> • Is the noise source apparent? → Yes REPAIR or INSTALL new components as necessary. → No GO to G3.
G3 CHECK FOR NOISE WHILE DISCONNECTING EACH FUEL INJECTOR ELECTRICAL CONNECTOR, ONE AT A TIME	
<div style="text-align: center;"> <p>1</p>  </div> <div style="text-align: center;"> <p>3</p>  </div>	<p>2 Disconnect each fuel injector electrical connector, one at a time, to decrease piston force and listen for the noise.</p>

(Continued)

100% SATISFACTION GUARANTEED

BUY IT NOW!

Click Here To Order

DIAGNOSIS AND TESTING (Continued)

PINPOINT TEST G: ENGINE TICKING, KNOCKING OR CONTINUOUS RATTLE (Continued)

CONDITIONS	DETAILS/RESULTS/ACTIONS
G3 CHECK FOR NOISE WHILE DISCONNECTING EACH FUEL INJECTOR ELECTRICAL CONNECTOR, ONE AT A TIME (Continued)	<ul style="list-style-type: none"> • Is the noise reduced or eliminated? → Yes INSTALL a new fuel injector. REFER to Section 303-04A for 4.2L engines or Section 303-04B for 4.6L and 5.4L engines. TEST the system for normal operation. → No INSPECT accessory drive or the transmission as a possible source.

PINPOINT TEST H: FRONT SUSPENSION NOISE

CONDITIONS	DETAILS/RESULTS/ACTIONS
H1 ROAD TEST THE VEHICLE	<ol style="list-style-type: none"> 1 Test drive the vehicle. 2 NOTE: An assistant will be needed for this road test. During the road test, drive the vehicle over a rough road. Using ChassisEARS, determine from which area/component the noise is originating. <ul style="list-style-type: none"> • Is there a squeak, creak or rattle noise? → Yes GO to H2. → No The suspension system is OK. CONDUCT a diagnosis on other suspect systems.
H2 INSPECT THE STEERING SYSTEM	<ol style="list-style-type: none"> 1  WARNING: The electrical power to the air suspension system must be shut off prior to hoisting, jacking or towing an air suspension vehicle. This can be accomplished by turning off the air suspension switch. Failure to do so can result in unexpected inflation or deflation of the air springs, which can result in shifting of the vehicle during these operations. Raise and support the vehicle. 2 Check the steering system for wear or damage. Carry out a steering linkage test. Refer to Section 211-00.

(Continued)



100% SATISFACTION GUARANTEED

BUY IT NOW!

Click Here To Order

PayPal American Express Discover MasterCard VISA

DIAGNOSIS AND TESTING (Continued)**PINPOINT TEST H: FRONT SUSPENSION NOISE (Continued)**

CONDITIONS	DETAILS/RESULTS/ACTIONS
H2 INSPECT THE STEERING SYSTEM (Continued)	<p data-bbox="826 312 1490 401">3 Inspect the tire wear pattern. Refer to Tire Wear Chart in Tire Wear Patterns and Frequency Calculations in this section.</p> <ul data-bbox="884 430 1372 488" style="list-style-type: none"> • Are the steering components worn or damaged? <p data-bbox="884 518 1490 634">→ Yes REPAIR the steering system. INSTALL new components as necessary. TEST the system for normal operation.</p> <p data-bbox="884 663 1069 721">→ No GO to H3.</p>
H3 FRONT SHOCK ABSORBER/STRUT CHECK	<p data-bbox="826 803 1490 861">1 Check the front shock absorbers/strut mounts for loose bolts or nuts.</p> <p data-bbox="826 907 1490 965">2 Check the front shock absorbers/struts for wear or damage. Carry out a “bounce test”</p> <ul data-bbox="884 994 1452 1052" style="list-style-type: none"> • Are the front shock absorbers/struts loose or damaged? <p data-bbox="884 1081 1490 1226">→ Yes TIGHTEN to specifications if loose. INSTALL new front shock absorbers/struts if damaged. TEST the system for normal operation.</p> <p data-bbox="884 1255 1069 1311">→ No GO to H4.</p>
H4 CHECK THE FRONT SPRINGS	<p data-bbox="826 1394 1490 1452">1 Check the front spring and front spring mounts/brackets for wear or damage.</p> <ul data-bbox="884 1481 1490 1539" style="list-style-type: none"> • Are the front springs or spring mounts/brackets worn or damaged? <p data-bbox="884 1568 1490 1684">→ Yes REPAIR or INSTALL new components as necessary. TEST the system for normal operation.</p> <p data-bbox="884 1713 1069 1769">→ No GO to H5.</p>

(Continued)

**BUY IT NOW!****Click Here To Order**

DIAGNOSIS AND TESTING (Continued)

PINPOINT TEST H: FRONT SUSPENSION NOISE (Continued)

CONDITIONS	DETAILS/RESULTS/ACTIONS
<p>H5 CHECK THE CONTROL ARMS/RADIUS ARMS</p>	<p>1 Inspect the control arm bushings for wear or damage.</p> <p>2 Inspect for twisted or bent control arms/radius arms.</p> <ul style="list-style-type: none"> • Are the control arms/radius arms damaged or worn? <p>→ Yes REPAIR or INSTALL new components as necessary. TEST the system for normal operation.</p> <p>→ No GO to H6.</p>
<p>H6 CHECK THE STABILIZER BAR/TRACK BAR</p>	<p>1 Check the stabilizer bar/track bar bushings and links for damage or wear.</p> <p>2 Check the stabilizer bar/track bar for damage.</p> <p>3 Check for loose or damaged stabilizer bar isolators or brackets.</p> <ul style="list-style-type: none"> • Are the stabilizer bar/track bar components loose, worn or damaged? <p>→ Yes REPAIR or INSTALL new components as necessary. TEST the system for normal operation.</p> <p>→ No Suspension system OK. CONDUCT diagnosis on other suspect systems.</p>

PINPOINT TEST I: REAR SUSPENSION NOISE

CONDITIONS	DETAILS/RESULTS/ACTIONS
<p>I1 ROAD TEST THE VEHICLE</p>	<p>1 Test drive the vehicle.</p>

(Continued)

100% SATISFACTION GUARANTEED

BUY IT NOW!

Click Here To Order

PayPal American Express Discover MasterCard VISA

DIAGNOSIS AND TESTING (Continued)

PINPOINT TEST I: REAR SUSPENSION NOISE (Continued)

CONDITIONS	DETAILS/RESULTS/ACTIONS
<p>I1 ROAD TEST THE VEHICLE (Continued)</p>	<p>2 NOTE: An assistant will be needed for this road test.</p> <p>During the road test, drive the vehicle over a rough road. Using ChassisEARS, determine from which area/component the noise is originating.</p> <ul style="list-style-type: none"> • Is there a squeak, creak or rattle noise? <p>→ Yes GO to I2.</p> <p>→ No The suspension system is OK. CONDUCT a diagnosis on other suspect systems.</p>
<p>I2 REAR SHOCK ABSORBER/STRUT CHECK</p>	<p>1  WARNING: The electrical power to the air suspension system must be shut off prior to hoisting, jacking or towing an air suspension vehicle. This can be accomplished by turning off the air suspension switch. Failure to do so can result in unexpected inflation or deflation of the air springs, which can result in shifting of the vehicle during these operations.</p> <p>Raise and support the vehicle.</p> <p>2 Check the rear shock absorber/strut mounts for loose bolts or nuts.</p> <p>3 Check the rear shock absorbers/struts for damage. Carry out a shock absorber check.</p> <ul style="list-style-type: none"> • Are the rear shock absorbers/struts loose or damaged? <p>→ Yes TIGHTEN to specifications if loose. INSTALL new rear shock absorbers/struts if damaged. TEST the system for normal operation.</p> <p>→ No GO to I3.</p>

(Continued)



BUY IT NOW!

Click Here To Order 



DIAGNOSIS AND TESTING (Continued)**PINPOINT TEST I: REAR SUSPENSION NOISE (Continued)**

CONDITIONS	DETAILS/RESULTS/ACTIONS
I3 CHECK THE REAR SPRINGS	<p data-bbox="770 327 1276 395">1 Check the rear springs and rear spring mounts/brackets for wear or damage.</p> <ul data-bbox="834 422 1417 478" style="list-style-type: none"> • Are the rear springs or spring mounts/brackets worn or damaged? <p data-bbox="834 505 1394 623">→ Yes REPAIR or INSTALL new components as necessary. TEST the system for normal operation.</p> <p data-bbox="834 650 1007 706">→ No GO to I4.</p>
I4 CHECK THE CONTROL ARMS/TRAILING ARMS	<p data-bbox="770 789 1394 886">1 Inspect the control arm/trailing arm bushings for wear or damage. Check for loose control arm/trailing arm bolts.</p> <p data-bbox="770 928 1378 984">2 Inspect for twisted or bent control arms/trailing arms.</p> <ul data-bbox="834 1011 1347 1067" style="list-style-type: none"> • Are the control arms/trailing arms loose, damaged or worn? <p data-bbox="834 1094 1394 1212">→ Yes REPAIR or INSTALL new components as necessary. TEST the system for normal operation.</p> <p data-bbox="834 1239 1002 1295">→ No GO to I5.</p>
I5 CHECK THE STABILIZER BAR/TRACK BAR	<p data-bbox="770 1384 1369 1440">1 Check the stabilizer bar/track bar bushings and links for damage or wear.</p> <p data-bbox="770 1487 1353 1514">2 Check the stabilizer bar/track bar for damage.</p>

(Continued)



BUY IT NOW!

Click Here To Order



DIAGNOSIS AND TESTING (Continued)

PINPOINT TEST I: REAR SUSPENSION NOISE (Continued)

CONDITIONS	DETAILS/RESULTS/ACTIONS
I5 CHECK THE STABILIZER BAR/TRACK BAR (Continued)	
	<p>3 Check for loose or damaged stabilizer bar isolators or brackets.</p> <ul style="list-style-type: none"> • Are the stabilizer bar/track bar components loose, worn or damaged? <p>→ Yes REPAIR or INSTALL new components as necessary. Test the system for normal operation.</p> <p>→ No Suspension system OK. CONDUCT diagnosis on other suspect systems.</p>

PINPOINT TEST J: WHEEL AND TIRE

CONDITIONS	DETAILS/RESULTS/ACTIONS
J1 ROAD TEST THE VEHICLE	
	<p>1 NOTE: Wheel or tire vibrations felt in the steering wheel are most likely related to the front wheel or tire. Vibration felt through the seat are most likely related to the rear wheel or tire. This may not always be true, but it can help to isolate the problem to the front or rear of the vehicle. Test drive the vehicle at different speed ranges.</p> <p>2 During the road test, if the vibration can be eliminated by placing the vehicle in neutral or is affected by the speed of the engine, the cause is not the wheels or tires.</p> <ul style="list-style-type: none"> • Is there a vibration and noise? <p>→ Yes GO to J2.</p> <p>→ No The wheel and tires are OK. CONDUCT a diagnosis on other suspect systems.</p>

(Continued)

100% SATISFACTION GUARANTEED

BUY IT NOW!

Click Here To Order

PayPal American Express Discover MasterCard VISA

DIAGNOSIS AND TESTING (Continued)

PINPOINT TEST J: WHEEL AND TIRE (Continued)

CONDITIONS	DETAILS/RESULTS/ACTIONS
<p>J2 CHECK THE FRONT WHEEL BEARINGS</p>	<p>1 Check the front wheel bearings. Refer to Wheel Bearing Check in this section.</p> <ul style="list-style-type: none"> • Are the wheel bearings OK? → Yes GO to J3. → No INSPECT the wheel bearings. ADJUST or REPAIR as necessary. TEST the system for normal operation.
<p>J3 INSPECT THE TIRES</p>	<p>1 Check the tires for missing weights.</p> <p>2 Check the wheels for damage.</p> <p>3 Inspect the tire wear pattern. Refer to the Tire Wear Patterns chart in this section.</p> <ul style="list-style-type: none"> • Do the tires have an abnormal wear pattern? → Yes CORRECT the condition that caused the abnormal wear. INSTALL new tire(s). TEST the system for normal operation. → No GO to J4.
<p>J4 TIRE ROTATION DIAGNOSIS</p> <div style="text-align: center;"> <p>1</p>  </div> <p>DF1713-A</p>	<p>1 Spin the tires slowly and watch for signs of lateral runout.</p>

(Continued)

100% SATISFACTION GUARANTEED

BUY IT NOW!

Click Here To Order

DIAGNOSIS AND TESTING (Continued)

PINPOINT TEST J: WHEEL AND TIRE (Continued)

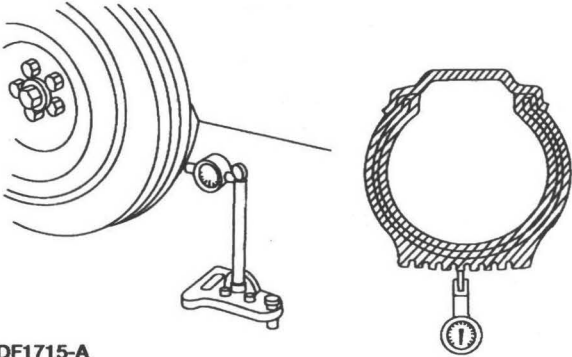
CONDITIONS	DETAILS/RESULTS/ACTIONS
J4 TIRE ROTATION DIAGNOSIS (Continued)	
<p style="text-align: center;">2</p>  <p style="text-align: left;">DF1714-A</p>	<p>2 Spin the tires slowly and watch for signs of radial runout.</p> <ul style="list-style-type: none"> • Are there signs of visual runout? → Yes GO to J5. → No CHECK the wheel and tire balance. CORRECT as necessary. TEST the system for normal operation.
J5 RADIAL RUNOUT CHECK ON THE TIRE	
<p style="text-align: center;">1</p>  <p style="text-align: left;">DF1715-A</p>	<p>1 Measure the radial runout of the wheel and tire assembly. A typical specification for total radial runout is 1.14 mm (0.04 in).</p> <ul style="list-style-type: none"> • Is the radial runout within specifications? → Yes GO to J8. → No GO to J6.
J6 RADIAL RUNOUT CHECK ON THE WHEEL	
	<p>1 Measure the radial runout of the wheel. A typical specification for total radial runout is 1.14 mm (0.04 in).</p> <ul style="list-style-type: none"> • Is the radial runout within specifications? → Yes INSTALL a new tire. TEST the system for normal operation. → No GO to J7.

(Continued)

100% SATISFACTION GUARANTEED

BUY IT NOW!

Click Here To Order



DIAGNOSIS AND TESTING (Continued)

PINPOINT TEST J: WHEEL AND TIRE (Continued)

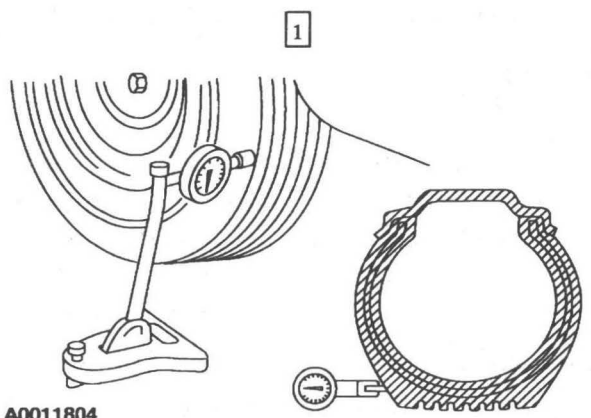
CONDITIONS	DETAILS/RESULTS/ACTIONS
<p>J7 CHECK THE HUB/BRAKE DISC OR DRUM PILOT RUNOUT OR BOLT CIRCLE RUNOUT</p>	<p>1 Measure the pilot or bolt circle runout. A typical specification for radial runout is:</p> <ul style="list-style-type: none"> • Pilot runout— less than 0.15 mm (0.006 inch). • Bolt circle runout— less than 0.38 mm (0.015 inch). <p>• Is the radial runout within specifications?</p> <p>→ Yes INSTALL a new wheel. TEST the system for normal operation.</p> <p>→ No REPAIR or INSTALL new components as necessary. REFER to Section 204-01A for 2-wheel drive front wheels, Section 204-01B for 4-wheel drive front wheels or Section 204-02 for the rear wheels.</p>
<p>J8 LATERAL RUNOUT CHECK ON THE TIRE</p>  <p>A0011804</p>	<p>1 Measure the lateral runout of the wheel and tire assembly. A typical specification for total lateral runout is 1.14 mm (0.04 in).</p> <p>• Is the lateral runout within specifications?</p> <p>→ Yes Wheel and tires OK. CONDUCT diagnosis on other suspect systems.</p> <p>→ No GO to J9.</p>
<p>J9 LATERAL RUNOUT CHECK ON THE WHEEL</p>	<p>1 Measure the lateral runout of the wheel. A typical specification for total radial runout is 1.14 mm (0.04 in).</p> <p>• Is the lateral runout within specifications?</p> <p>→ Yes INSTALL a new tire. TEST the system for normal operation.</p> <p>→ No GO to J10.</p>

(Continued)

100% SATISFACTION GUARANTEED

BUY IT NOW!

Click Here To Order 







DIAGNOSIS AND TESTING (Continued)

PINPOINT TEST J: WHEEL AND TIRE (Continued)

CONDITIONS	DETAILS/RESULTS/ACTIONS
J10 CHECK THE FLANGE FACE LATERAL RUNOUT	
	<ol style="list-style-type: none"> 1 Measure the flange face lateral runout. A typical specification for lateral runout is: <ul style="list-style-type: none"> • Hub/brake disc— less than 0.13 mm (0.005 inch). • Axle shaft— less than 0.25 mm (0.010 inch). <ul style="list-style-type: none"> • Is the lateral runout within specifications? <ul style="list-style-type: none"> → Yes INSTALL a new wheel. TEST the system for normal operation. → No REPAIR or INSTALL new components as necessary. REFER to Section 204-01A for 2-wheel drive front wheels, Section 204-01B for 4-wheel drive front wheels or Section 204-02 for the rear wheels.

PINPOINT TEST K: HIGH SPEED SHAKE OR SHIMMY

CONDITIONS	DETAILS/RESULTS/ACTIONS
K1 CHECK FOR FRONT WHEEL BEARING ROUGHNESS	
	<ol style="list-style-type: none"> 1 Chock the rear wheels. 2 Raise and support the front end of the vehicle so that the front wheel and tire assemblies can spin. 3 Spin the front tires by hand. Refer to Wheel Bearing Check in this section. <ul style="list-style-type: none"> • Do the wheel bearings feel rough? <ul style="list-style-type: none"> → Yes INSPECT the wheel bearings. REPAIR as necessary. TEST the system for normal operation. → No GO to K2.

(Continued)

100% SATISFACTION GUARANTEED

BUY IT NOW!

Click Here To Order

PayPal American Express Discover MasterCard VISA

DIAGNOSIS AND TESTING (Continued)**PINPOINT TEST K: HIGH SPEED SHAKE OR SHIMMY (Continued)**

CONDITIONS	DETAILS/RESULTS/ACTIONS
K2 CHECK THE END PLAY OF THE FRONT WHEEL BEARINGS	<p>1 Check the end play of the front wheel bearings. Refer to Section 204-01A for 2-wheel drive front wheels, Section 204-01B for 4-wheel drive front wheels or Section 204-02 for the rear wheels.</p> <ul style="list-style-type: none"> • Is the end play OK? <p>→ Yes GO to K3.</p> <p>→ No ADJUST or REPAIR as necessary. TEST the system for normal operation.</p>
K3 MEASURE THE LATERAL RUNOUT AND THE RADIAL RUNOUT OF THE FRONT WHEELS ON THE VEHICLE	<p>1 Measure the lateral runout and the radial runout of the front wheels on the vehicle. GO to Pinpoint Test J.</p> <ul style="list-style-type: none"> • Are the measurements within specifications? <p>→ Yes GO to K4.</p> <p>→ No INSTALL new wheels as necessary and BALANCE the assembly. TEST the system for normal operation.</p>
K4 MEASURE THE LATERAL RUNOUT OF THE FRONT TIRES ON THE VEHICLE	<p>1 Measure the lateral runout of the front tires on the vehicle. GO to Pinpoint Test J.</p> <ul style="list-style-type: none"> • Is the runout within specifications? <p>→ Yes GO to K5.</p> <p>→ No INSTALL new tires as necessary and BALANCE the assembly. TEST the system for normal operation.</p>

(Continued)



BUY IT NOW!

Click Here To Order 







DIAGNOSIS AND TESTING (Continued)

PINPOINT TEST K: HIGH SPEED SHAKE OR SHIMMY (Continued)

CONDITIONS	DETAILS/RESULTS/ACTIONS
K5 MEASURE THE RADIAL RUNOUT OF THE FRONT TIRES ON THE VEHICLE	
	<p>1 Measure the radial runout of the front tires on the vehicle. GO to Pinpoint Test J.</p> <ul style="list-style-type: none"> • Is the runout within specifications? → Yes BALANCE the front wheel and tire assemblies. If any tire cannot be balanced, INSTALL a new tire. TEST the system for normal operation. → No GO to K6.
K6 MATCH MOUNT THE TIRE AND WHEEL ASSEMBLY	
	<p>1 Mark the high runout location on the tire and also on the wheel. Break the assembly down and rotate the tire 180 degrees (halfway around) on the wheel. Inflate the tire and measure the radial runout.</p> <ul style="list-style-type: none"> • Is the runout within specifications? → Yes BALANCE the assembly. TEST the system for normal operation. → No If the high spot is not within 101.6 mm (4 inches) of the first high spot on the tire, GO to K7.

(Continued)

100% SATISFACTION GUARANTEED

BUY IT NOW!

Click Here To Order

PayPal American Express Cards DISCOVER NEW! MasterCard VISA

DIAGNOSIS AND TESTING (Continued)**PINPOINT TEST K: HIGH SPEED SHAKE OR SHIMMY (Continued)**

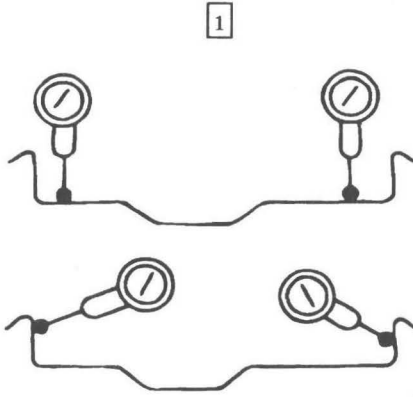
CONDITIONS	DETAILS/RESULTS/ACTIONS
<p>K7 MEASURE THE WHEEL FLANGE RUNOUT</p> <div style="text-align: center;">  <p>DG0199-A</p> </div>	<p>1 Dismount the tire and mount the wheel on a wheel balancer. Measure the runout on both wheel flanges. Refer to Section 204-04.</p> <ul style="list-style-type: none"> • Is the runout within specifications? → Yes LOCATE and MARK the low spot on the wheel. INSTALL the tire, matching the high spot on the tire with the low spot on the wheel. BALANCE the assembly. TEST the system for normal operation. If the condition persists, GO to K8. → No INSTALL a new wheel. CHECK the runout on the new wheel. If the new wheel is within limits, LOCATE and MARK the low spot. INSTALL the tire, matching the high spot on the tire with the low spot on the wheel. BALANCE the assembly. TEST the system for normal operation. If the condition persists, GO to K8.
<p>K8 CHECK FOR VIBRATION FROM THE FRONT OF THE VEHICLE</p> <p>⚠ WARNING: If only one drive wheel is allowed to rotate, speed must be limited to 55 km/h (34 mph) using the speedometer reading, since actual wheel speed will be twice that indicated on the speedometer. Exceeding a speed of 55 km/h (34 mph) or allowing the drive wheel to hang unsupported can result in tire disintegration or differential failure, which can cause serious personal injury and extensive vehicle damage.</p>	
	<p>1 Spin the front wheel and tire assemblies with a wheel balancer while the vehicle is raised on a hoist. Feel for vibration in the front fender or while seated in the vehicle.</p> <ul style="list-style-type: none"> • Is the vibration present? → Yes SUBSTITUTE known good wheel and tire assemblies as necessary. TEST the system for normal operation. → No GO to K9.

(Continued)

100% SATISFACTION GUARANTEED

BUY IT NOW!

Click Here To Order



DIAGNOSIS AND TESTING (Continued)**PINPOINT TEST K: HIGH SPEED SHAKE OR SHIMMY (Continued)**

CONDITIONS	DETAILS/RESULTS/ACTIONS
K9 CHECK FOR VIBRATION FROM THE REAR OF THE VEHICLE	
<p>⚠ WARNING: If only one drive wheel is allowed to rotate, speed must be limited to 55 km/h (34 mph) using the speedometer reading, since actual wheel speed will be twice that indicated on the speedometer. Exceeding a speed of 55 km/h (34 mph) or allowing the drive wheel to hang unsupported can result in tire disintegration or differential failure, which can cause serious personal injury and extensive vehicle damage.</p>	
	<ol style="list-style-type: none"> 1 Chock the front wheels. 2 Raise and support the rear end of the vehicle so that the rear wheel and tire assemblies can spin. 3 Engage the drivetrain and carefully accelerate the drive wheels while checking for vibration. <ul style="list-style-type: none"> • Is the vibration present? <ul style="list-style-type: none"> → Yes GO to K10. → No TEST the system for normal operation.
K10 CHECK THE DRIVETRAIN	
<p>⚠ WARNING: If only one drive wheel is allowed to rotate, speed must be limited to 55 km/h (34 mph) using the speedometer reading, since actual wheel speed will be twice that indicated on the speedometer. Exceeding a speed of 55 km/h (34 mph) or allowing the drive wheel to hang unsupported can result in tire disintegration or differential failure, which can cause serious personal injury and extensive vehicle damage.</p>	
	<ol style="list-style-type: none"> 1 Remove the rear wheel and tire assemblies. Refer to Section 204-04. 2 Secure the brake drums (if so equipped), by installing wheel hub bolt nuts, reversed. 3 Carefully accelerate the drivetrain while checking for vibration. <ul style="list-style-type: none"> • Is the vibration present? <ul style="list-style-type: none"> → Yes CHECK/TEST the drivetrain and driveline components. TEST the system for normal operation. → No SUBSTITUTE known good wheel and tire assemblies as necessary. TEST the system for normal operation.



BUY IT NOW!

Click Here To Order



DIAGNOSIS AND TESTING (Continued)

PINPOINT TEST L: CLUTCH VIBRATION

CONDITIONS	DETAILS/RESULTS/ACTIONS
<p>L1 CHECK ENGINE COMPONENTS FOR GROUNDING</p>	<p>1 NOTE: Make sure the clutch is the cause of the vibration concern. The vibration should occur during clutch operation. The clutch can also be difficult to engage or disengage. Eliminate all related systems before checking the clutch components.</p> <p>NOTE: Check the driveline angles and driveshaft runout before disassembling the clutch system. Refer to Section 205-00 for the correct driveline angle specifications.</p> <p>Check the powertrain/drivetrain mounts, exhaust manifolds or other engine components for grounding on the chassis.</p> <ul style="list-style-type: none"> • Are any mounts or engine components grounded? <p>→ Yes REPAIR as necessary. TEST the system for normal operation.</p> <p>→ No GO to L2.</p>
<p>L2 CHECK THE ACCESSORY DRIVE BELT</p>	<p>1 Remove the accessory drive belt.</p> <ul style="list-style-type: none"> • Does the vibration stop with the accessory drive belt removed? <p>→ Yes DIAGNOSE the accessory drive components.</p> <p>→ No GO to L3.</p>
<p>L3 CHECK FOR LOOSE CLUTCH PRESSURE PLATE BOLTS</p>	<p>1 Check for loose clutch pressure plate bolts. Inspect the clutch pressure plate for damage or for material between the pressure plate and flywheel.</p> <ul style="list-style-type: none"> • Are there any loose bolts or damage? <p>→ Yes TIGHTEN the bolts to specifications or if damaged, INSTALL a new clutch pressure plate. REFER to Section 308-01. TEST the system for normal operation.</p> <p>→ No GO to L4.</p>

(Continued)

100% SATISFACTION GUARANTEED

BUY IT NOW!

Click Here To Order

PayPal American Express Discover MasterCard VISA

DIAGNOSIS AND TESTING (Continued)

PINPOINT TEST L: CLUTCH VIBRATION (Continued)

CONDITIONS	DETAILS/RESULTS/ACTIONS
L4 CHECK THE CLUTCH DISC SPRINGS	
	<p>1 Check for worn, broken or loose clutch disc springs.</p> <ul style="list-style-type: none"> • Are the clutch springs worn, broken or loose? <p>→ Yes INSTALL a new clutch disc. REFER to Section 308-01. TEST the system for normal operation.</p> <p>→ No GO to L5.</p>
L5 CHECK THE CLUTCH DISC SPLINES	
	<p>1 Inspect the clutch disc splines for damage or wear.</p> <ul style="list-style-type: none"> • Is there damage or wear? <p>→ Yes INSTALL a new clutch disc. REFER to Section 308-01. TEST the system for normal operation.</p> <p>→ No GO to L6.</p>
L6 CHECK THE FLYWHEEL BOLTS	
	<p>1 Check for loose flywheel bolts.</p> <ul style="list-style-type: none"> • Are the bolts loose? <p>→ Yes TIGHTEN the bolts to specifications. TEST the system for normal operation.</p> <p>→ No GO to L7.</p>
L7 CHECK THE FLYWHEEL SURFACE	
	<p>1 Inspect the flywheel surface for wear or damage. Check the flywheel runout.</p> <ul style="list-style-type: none"> • Is there any damage or excessive wear? <p>→ Yes INSTALL a new flywheel. REFER to Section 303-01A for 4.2L engines or Section 303-01B for 4.6L and 5.4L engines. TEST the system for normal operation.</p> <p>→ No Clutch system normal. CONDUCT a diagnosis on other suspect systems.</p>



BUY IT NOW!
Click Here To Order



DIAGNOSIS AND TESTING (Continued)

PINPOINT TEST M: TRANSFER CASE VIBRATION

CONDITIONS	DETAILS/RESULTS/ACTIONS
<p>M1 INSPECT THE TRANSFER CASE</p>	<p>1  WARNING: The electrical power to the air suspension system must be shut off prior to hoisting, jacking or towing an air suspension vehicle. This can be accomplished by turning off the air suspension switch. Failure to do so can result in unexpected inflation or deflation of the air springs, which can result in shifting of the vehicle during these operations.</p> <p>Inspect the transfer case for loose or missing mounting bolts. Check for fluid seepage between the transfer case and the transmission.</p> <ul style="list-style-type: none"> • Are the mounting bolts missing or loose? <p>→ Yes TIGHTEN to specifications or INSTALL new bolts as necessary. TEST the system for normal operation.</p> <p>→ No GO to M2.</p>
<p>M2 INSPECT THE REAR DRIVESHAFT</p>	<p>1 NOTE: Verify that the driveshaft and pinion flange index marks are aligned.</p> <p>Inspect the driveshaft for missing weights, damage or undercoating.</p> <p>2 Inspect the U-joints for freedom of movement.</p> <p>3 Check driveshaft runout and, if necessary, check the pinion flange runout.</p> <ul style="list-style-type: none"> • Is the driveshaft or U-joints worn or damaged or misaligned? <p>→ Yes REPAIR or INSTALL a new driveshaft as necessary. TEST the system for normal operation.</p> <p>→ No GO to M3.</p>
<p>M3 CHECK THE DRIVELINE ANGLES</p>	<p>1 Measure the rear driveshaft and pinion angles. Refer to Section 205-00.</p>

(Continued)



BUY IT NOW!

Click Here To Order



DIAGNOSIS AND TESTING (Continued)

PINPOINT TEST M: TRANSFER CASE VIBRATION (Continued)

CONDITIONS	DETAILS/RESULTS/ACTIONS
M3 CHECK THE DRIVELINE ANGLES (Continued)	
	<p>2 Measure the front driveshaft and pinion angles. Refer to the appropriate workshop manual for the service procedures.</p> <ul style="list-style-type: none"> • Are the driveline angles incorrect? → Yes REPAIR as necessary. TEST the system for normal operation. → No GO to M4.
M4 INSPECT THE FRONT DRIVESHAFT	
	<p>1 NOTE: Verify that the driveshaft and pinion flange index marks are aligned. Inspect the front driveshaft for missing weights, damage or undercoating.</p> <p>2 Inspect the U-joints and slip yoke for freedom of movement.</p> <p>3 Check driveshaft runout and, if necessary, check the pinion flange runout. Refer to Section 205-00.</p> <ul style="list-style-type: none"> • Is the driveshaft or U-joints worn or damaged? → Yes REPAIR or INSTALL a new driveshaft as necessary. TEST the system for normal operation. → No GO to M5.
M5 ROAD TEST WITH THE FRONT DRIVESHAFT ONLY	
	<p>1 NOTE: Index mark the driveshaft to the pinion flange and to the output shaft before removal. Remove the rear driveshaft.</p> <p>2 Plug the transfer case with an output shaft seal plug.</p>

(Continued)

100% SATISFACTION GUARANTEED

BUY IT NOW!

Click Here To Order

PayPal Discover MasterCard VISA

DIAGNOSIS AND TESTING (Continued)

PINPOINT TEST M: TRANSFER CASE VIBRATION (Continued)

CONDITIONS	DETAILS/RESULTS/ACTIONS
M5 ROAD TEST WITH THE FRONT DRIVESHAFT ONLY (Continued)	
	<p>3 NOTE: Shift the transfer case into 4WD high so the vehicle is driven by the front driveshaft only. Test drive the vehicle.</p> <ul style="list-style-type: none"> • Is the vibration gone? → Yes INSTALL and BALANCE the rear driveshaft. TEST the system for normal operation. → No GO to M6.
M6 ROAD TEST WITH THE REAR DRIVESHAFT ONLY	
	<p>1 NOTE: Index mark the front driveshaft to the pinion flange. Remove the front driveshaft.</p> <p>2 Test drive the vehicle.</p> <ul style="list-style-type: none"> • Is the vibration gone? → Yes INSTALL and BALANCE the front driveshaft. TEST the system for normal operation. → No GO to M7.
M7 TRANSFER CASE TAIL SHAFT INSPECTION	
	<p>1 Inspect the splines of the output shaft for wear or damage.</p> <p>2 Inspect the splines of the driveshaft slip yoke for wear or damage.</p> <ul style="list-style-type: none"> • Are the splines worn or damaged? → Yes REPAIR or INSTALL new components as necessary. TEST the system for normal operation. → No The transfer case is OK. CONDUCT a diagnosis on other suspect systems.



BUY IT NOW!

Click Here To Order



DIAGNOSIS AND TESTING (Continued)

Component Tests

Idle Air Control (IAC) Valve

1. Open the hood.
2. **NOTE:** Key symptom is elevated idle speed while noise is occurring.
NOTE: "Snapping" the throttle can induce the noise.
Verify the condition by operating the vehicle for a short time.
3. Inspect the IAC valve. If physical evidence of contamination exists, install a new IAC valve.
4. While the noise is occurring, either place an EngineEAR probe near the IAC valve and the inlet tube, or create a 6.35 mm (0.25 in)-12.7 mm (0.50 in) air gap between the inlet tube and the clean air tube. If the IAC valve is making the noise, install a new IAC valve.
5. Test the vehicle for normal operation.

Steering Gear Grunt/Shudder Test

1. Start and run the vehicle to operating temperature.
2. Set engine idle speed to 1200 rpm.
3.  **CAUTION: Do not hold the steering wheel against the stops for more than three to five seconds at a time. Damage to the power steering pump will occur.**

Rotate the steering wheel to the RH stop, then turn the steering wheel 90° back from that position. Turn the steering wheel slowly in a 15° to 30° arc.

4. Turn the steering wheel another 90°. Turn the steering wheel slowly in a 15° to 30° arc.
5. Repeat the test with power steering fluid at different temperatures.
6. If a light grunt is heard or a low (50-200 Hz) shudder is present, this is a normal steering system condition.
7. If a loud grunt is heard or a strong shudder is felt, fill and purge the power steering system.

Checking Tooth Contact Pattern and Condition of the Ring and Pinion

There are two basic types of conditions that will produce ring and pinion noise. The first type is a howl or chuckle produced by broken, cracked, chipped, scored or forcibly damaged gear teeth and is usually quite audible over the entire speed range. The second type of ring and pinion noise pertains to the mesh pattern of the gear pattern. This gear noise can be recognized as it produces a cycling pitch or whine. Ring and pinion noise tends to peak in a narrow speed range or ranges, and will tend to remain constant in pitch.

1. Raise and support the vehicle. For additional information, refer to Section 100-02.
2. Drain the axle lubricant. Refer to Section 205-02A for Ford 8.8 rear axles, Section 205-02B for Ford 9.75 rear axles, Section 205-02C for Ford 10.25 rear axles or Section 205-03 for front axles.
3. Remove the carrier assembly or the axle housing cover depending on the axle type. Refer to Section 205-02A for Ford 8.8 rear axles, Section 205-02B for Ford 9.75 rear axles, Section 205-02C for Ford 10.25 rear axles or Section 205-03 for front axles.
4. Inspect the gear set for scoring or damage.

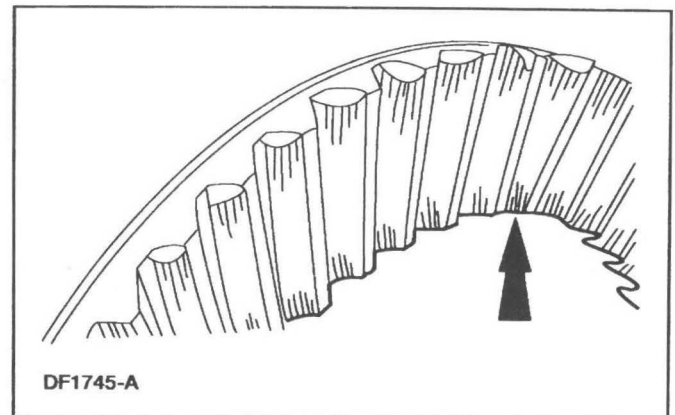

100% SATISFACTION GUARANTEED

BUY IT NOW!

Click Here To Order





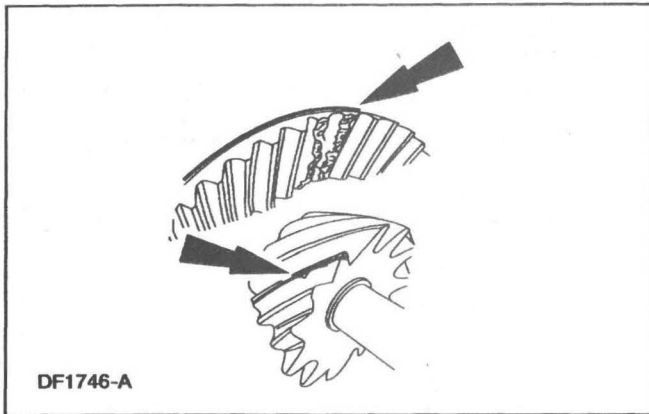

DIAGNOSIS AND TESTING (Continued)

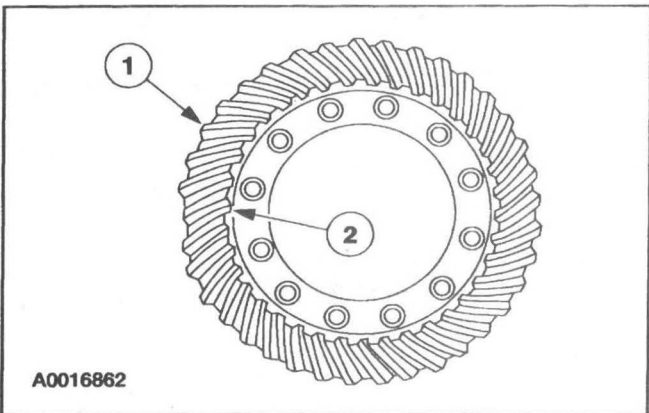

5. In the following steps, the movement of the contact pattern along the length is indicated as toward the “heel” or “toe” of the differential ring gear.



Item	Description
1	Heel
2	Toe

6. Apply a marking compound to a third of the gear teeth on the differential ring gear. Rotate the differential ring gear several complete turns in both directions until a good, clear tooth pattern is obtained. Inspect the contact patterns on the ring gear teeth.

7. A good contact pattern should be centered on the tooth. It can also be slightly toward the toe. There should always be some clearance between the contact pattern and the top of the tooth.

- Tooth contact pattern shown on the drive side of the gear teeth.

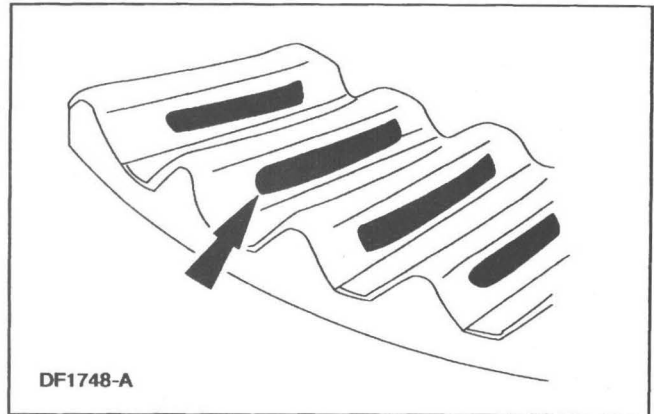

8. A high, thick contact pattern that is worn more toward the toe.

- Tooth contact pattern shown on the drive side of the gear teeth.
- The high contact pattern indicates that the drive pinion is not installed deep enough into the carrier.
- The differential ring gear backlash is correct, a thinner drive pinion shim is needed. A decrease will move the drive pinion toward the differential ring gear.

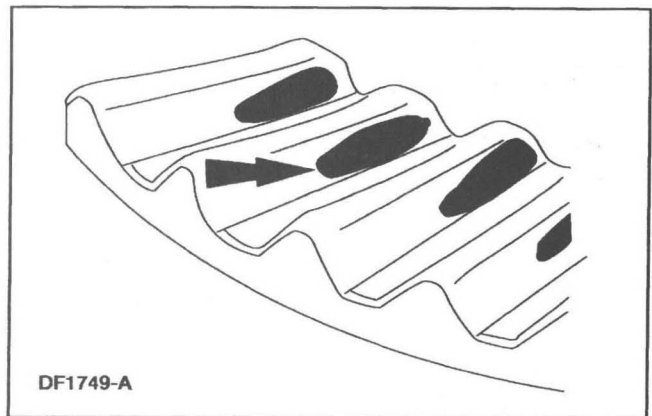

100% SATISFACTION GUARANTEED

BUY IT NOW!

Click Here To Order

DIAGNOSIS AND TESTING (Continued)

9. A high, thin contact pattern that is worn toward the toe.
- Tooth contact pattern shown on the drive side of the gear teeth.
 - The drive pinion depth is correct. Increase the differential ring gear backlash.

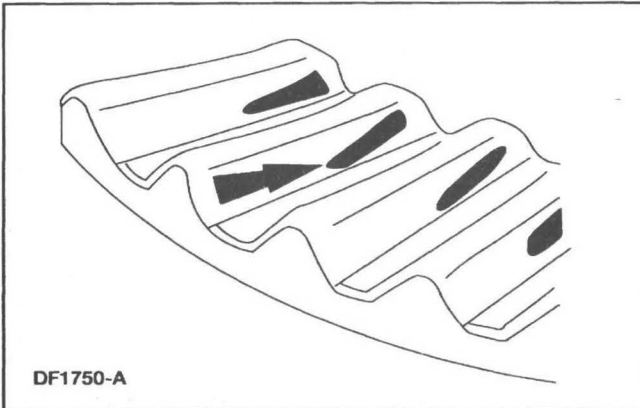

11. A contact pattern that is worn at the top of the differential ring gear tooth toward the heel.
- Tooth contact pattern shown on the drive side of the gear teeth.
 - The pinion gear depth is correct. Decrease the differential ring gear backlash.

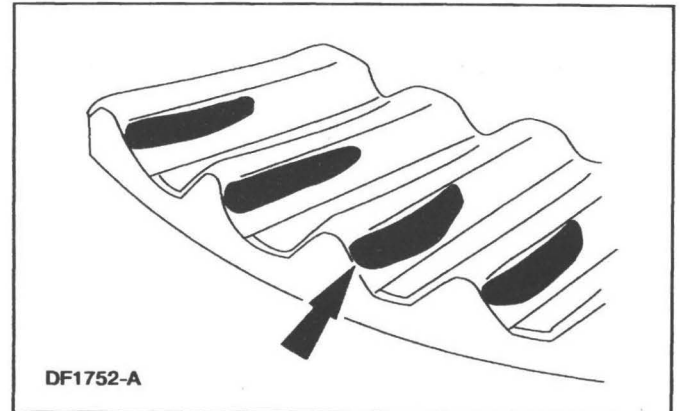

10. A contact pattern that is worn in the center of the differential ring gear tooth toward the heel.
- Tooth contact pattern shown on the drive side of the gear teeth.
 - The low contact pattern indicates that the drive pinion is installed too deep into the carrier.
 - The differential ring gear backlash is correct. A thicker drive pinion shim is needed.

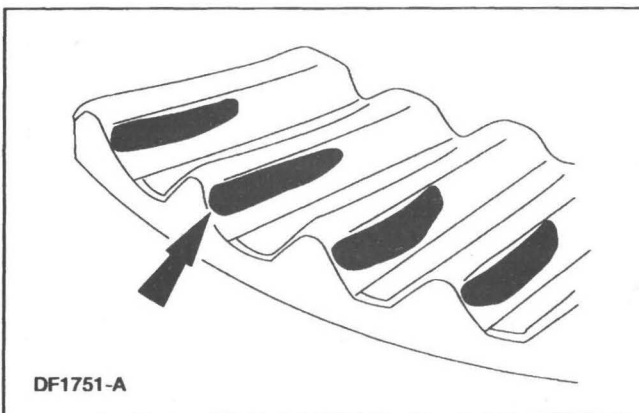

BUY IT NOW!



Click Here To Order



DIAGNOSIS AND TESTING (Continued)

Tire Wear Patterns and Frequency Calculations

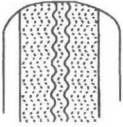
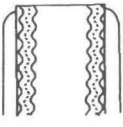
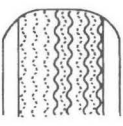
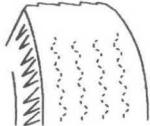
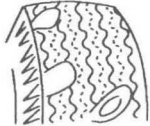
Tire Wear Chart

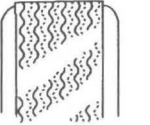
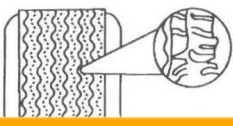
TIRE WEAR	CONDITION	POSSIBLE CAUSES
	<ul style="list-style-type: none"> • Rapid wear at both shoulders. 	<ul style="list-style-type: none"> • Tires underinflated. • Worn suspension components. • Excessive cornering speeds. • Lack of rotation.
	<ul style="list-style-type: none"> • Rapid wear at the center. 	<ul style="list-style-type: none"> • Tires overinflated. • Lack of rotation. • Excessive toe on drive wheels. • Heavy acceleration on drive wheels.
	<ul style="list-style-type: none"> • Wear at one shoulder. 	<ul style="list-style-type: none"> • Toe adjustment out of specification. • Camber out of specification. • Damaged strut. • Damaged lower control arm.
	<ul style="list-style-type: none"> • Feather edges. 	<ul style="list-style-type: none"> • Toe adjustment out of specification. • Damaged or worn tie rods. • Damaged spindle or knuckle.
	<ul style="list-style-type: none"> • Bald spots or cupping. 	<ul style="list-style-type: none"> • Unbalanced wheel. • Excessive radial runout. • Worn strut or shock absorber.
	<ul style="list-style-type: none"> • Tire scalloped. 	<ul style="list-style-type: none"> • Toe adjustment out of specification. • Camber out of specification. • Worn or damaged suspension components.
	<ul style="list-style-type: none"> • Wear pattern - FWD vehicles. 	<ul style="list-style-type: none"> • Excessive toe on non-drive wheels. • Lack of rotation.
	<ul style="list-style-type: none"> • Wear pattern - FWD vehicles. Edge of thread blocks worn. 	<ul style="list-style-type: none"> • Excessive toe on non-drive wheels. • Lack of rotation.



BUY IT NOW!

Click Here To Order



DIAGNOSIS AND TESTING (Continued)

Wheel and tire NVH concerns are directly related to vehicle speed and are not generally affected by acceleration, coasting or decelerating. Also, out-of-balance wheel and tires can vibrate at more than one speed. A vibration that is affected by the engine rpm, or is eliminated by placing the transmission in NEUTRAL is not related to the tire and wheel. As a general rule, tire and wheel vibrations felt in the steering wheel are related to the front tire and wheel assemblies. Vibrations felt in the seat or floor are related to the rear tire and wheel assemblies. This can initially isolate a concern to the front or rear.

Careful attention must be paid to the tire and wheels. There are several symptoms that can be caused by damaged or worn tire and wheels. Carry out a careful visual inspection of the tires and wheel assemblies. Spin the tires slowly and watch for signs of lateral or radial runout. Refer to the tire wear chart to determine the tire wear conditions and actions.

For a vibration concern, use the vehicle speed to determine tire/wheel frequency and rpm. Calculate tire and wheel rpm and frequency by carrying out and following:

- Measure the diameter of the tire.
- Record the speed at which the vibration occurs.
- Obtain the corresponding tire and wheel rpm and frequency from the Tire Speed and Frequency Chart.
 - If the vehicle speed is not listed, divide the vehicle speed at which the vibration occurs by 16 km/h (10 mph). Multiply that number by 16 km/h (10 mph) tire rpm listed for that tire diameter in the chart. Then divide that number by 60. For example: a 40 mph vibration with 835 mm (33 in) tires. $40 \div 10 = 4$. Multiply 4 by 105 = 420 rpm. Divide 420 rpm by 60 seconds = 7 Hz at 40 mph.

Tire Speed and Frequency Chart

Tire Diameter	Tire RPM/Hz	Tire RPM/Hz	Tire RPM/Hz	Tire RPM/Hz
mm (inch)	@ 16 km/h (10 mph)	@ 80 km/h (50 mph)	@ 97 km/h (60 mph)	@ 113 km/h (70 mph)
483 (19)	182	910/15	1092/18	1274/21
508 (20)	173	865/14	1038/17	1211/20
533 (21)	165	825/14	990/16	1155/19
560 (22)	158	790/13	948/16	1106/18
585 (23)	151	755/13	906/15	1057/18
610 (24)	145	725/12	870/14	1015/17
635 (25)	139	695/12	834/14	973/16
660 (26)	134	670/11	804/13	938/16
685 (27)	129	645/11	774/13	903/15
710 (28)	124	620/10	744/12	868/14
735 (29)	119	595/10	714/12	833/14
760 (30)	115	575/10	690/11	805/13
785 (31)	111	555/9	666/11	777/13
810 (32)	108	540/9	648/11	756/13
835 (33)	105	525/9	630/10	735/12
864 (34)	102	510/8	612/10	714/12

100% SATISFACTION GUARANTEED

BUY IT NOW!

Click Here To Order

GENERAL PROCEDURES

Brake Disc Machining

Special Tool(s)

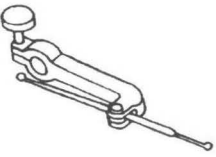
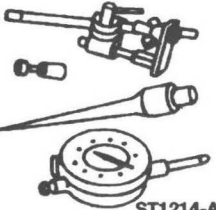
 <p>ST1348-A</p>	<p>Gauge, Clutch Housing 308-021 (T75L-4201-A)</p>
 <p>ST1214-A</p>	<p>Dial Indicator Gauge with Holding Fixture 100-002 (TOOL-4201-C) or equivalent</p>

Materials

Item	Specification
<p>Metal Surface Cleaner F4AZ-19A536-RA or equivalent</p>	<p>WSE-M5B392-A</p>
<p>High Temperature Nickel Anti-Seize Lubricant F6AZ-9L494-AA or equivalent</p>	<p>ESE-M12A4-A</p>

⚠ WARNING: The electrical power to the air suspension system must be shut off prior to hoisting, jacking or towing an air suspension vehicle. This can be accomplished by turning off the air suspension switch. Failure to do so can result in unexpected inflation or deflation of the air springs, which can result in shifting of the vehicle during these operations.

⚠ CAUTION: Do not install brake discs that are less than the minimum thickness specified. Do not machine a brake disc below the minimum thickness specification.

1. Check wheel bearing end-play and correct as necessary.
2. **NOTE:** Begin at the front of the vehicle unless the vibration has been isolated to the rear.
Remove the tire and wheel assembly.
3. Remove the brake caliper and the brake caliper anchor plate. Refer to the appropriate section in Group 206 for the procedure.
4. Inspect the brake linings. Install new brake linings if below specification. For additional information, refer to the appropriate brake section.

100% SATISFACTION GUARANTEED

BUY IT NOW!

Click Here To Order



GENERAL PROCEDURES (Continued)

5. Measure and record the brake disc thickness. Install a new brake disc if the thickness after machining will be at or below specification. The specification is molded into the brake disc.
 - Do not machine a new brake disc.

6. For vehicles with a two-piece hub and brake disc assembly:
 - Match-mark before disassembly.
 - Remove the brake disc.
 - Clean the hub and brake disc mounting surfaces with metal surface cleaner.
 - Using a die grinder with a mild abrasive (Scotch Brite® type), remove any rust or corrosion from the hub and brake disc mounting surfaces.
 - Align the match-marks and reinstall the brake disc on the hub.

7.  **CAUTION: Do not use a bench lathe to machine brake discs.**

NOTE: The depth of cut must be between 0.10 and 0.20 mm (0.004 and 0.008 inch). Lighter cuts will cause heat and wear. Heavier cuts will cause poor brake disc surface finish.

Using an on-car brake lathe, machine the brake discs. Follow the manufacturer's instructions. After machining, make sure the brake disc still meets the thickness specification.

8. Using the special tools, verify that the brake disc lateral runout is now within specification. For additional information, refer to Section 206-00.

9. Remove the special tool hub adapter.

10. Remove any remaining metal chips from the machining operation.



BUY IT NOW!
Click Here To Order 



GENERAL PROCEDURES (Continued)

11. For vehicles with a two-piece hub and brake disc assembly:
 - Remove the brake disc from the hub.
 - Remove any remaining metal chips from hub and brake disc mounting surfaces and from the ABS sensor.
 - Apply a liberal amount of lubricant to the hub flange, pilot area and to the brake disc-to-hub mounting surface.
 - Using the match marks, mount the brake disc on the hub.
12. Install the brake caliper anchor plate and the brake caliper.
13. Install the tire and wheel assembly.
14. Test the system for normal operation.

Powertrain/Drivetrain Mount Neutralizing

⚠ WARNING: The electrical power to the air suspension system must be shut off prior to hoisting, jacking or towing an air suspension vehicle. This can be accomplished by turning off the air suspension switch. Failure to do so can result in unexpected inflation or deflation of the air springs, which can result in shifting of the vehicle during these operations.

1. Raise and support the vehicle.
2. Loosen, but do not remove, the powertrain/drivetrain mount fasteners.
3. Lower the vehicle.
4. **⚠ CAUTION:** Do not twist or strain the powertrain/drivetrain mounts.
Move the vehicle in forward and reverse 0.6-1.2 meters (2-4 ft).
5. Raise and support the vehicle.
6. Tighten the powertrain/drivetrain mount fasteners.



GENERAL PROCEDURES (Continued)

7. Lower the vehicle.
8. Test the system for normal operation.

Exhaust System Neutralizing

⚠ WARNING: Exhaust gases contain carbon monoxide, which is harmful to health and potentially lethal. Repair exhaust system leaks immediately. Never operate the engine in an enclosed area.

⚠ WARNING: Exhaust system components are hot.

NOTE: Neutralize the exhaust system to relieve strain on mounts which can be sufficiently bound up to transmit vibration as if grounded.

1. **⚠ WARNING: The electrical power to the air suspension system must be shut off prior to hoisting, jacking or towing an air suspension vehicle. This can be accomplished by turning off the air suspension switch. Failure to do so can result in unexpected inflation or deflation of the air springs, which can result in shifting of the vehicle during these operations.**

⚠ CAUTION: Make sure the system is warmed up to normal operating temperature, as thermal expansion can be the cause of a strain problem.

Raise and support the vehicle.

2. Loosen all exhaust hanger attachments and reposition the hangers until they hang free and straight.
3. Loosen all exhaust flange joints.
4. Place a stand to support the muffler parallel to the vehicle frame with the muffler pipe bracket free of stress.
5. Tighten the muffler connection.



100% SATISFACTION GUARANTEED

BUY IT NOW!

Click Here To Order

PayPal American Express Discover MasterCard VISA

GENERAL PROCEDURES (Continued)

6. Tighten all the exhaust hanger clamps and flanges (tighten the exhaust manifold flange joint last).
 - Verify there is adequate clearance to prevent grounding at any point in the system. Make sure that the catalytic converter and heat shield do not contact the frame rails.
 - After neutralization, the rubber in the exhaust hangers should show some flexibility when movement is applied to the exhaust system.
 - With the exhaust system installed securely and cooled, the rear hanger should be angled forward.
7. Lower the vehicle.
8. Test the exhaust system for normal operation.

Wheel Bearing Check

1.  **WARNING:** The electrical power to the air suspension system must be shut off prior to hoisting, jacking or towing an air suspension vehicle. This can be accomplished by turning off the air suspension switch. Failure to do so can result in unexpected inflation or deflation of the air springs, which can result in shifting of the vehicle during these operations.

Raise the vehicle until the front tires are off the floor.

- Make sure the wheels are in a straight forward position.

2. **NOTE:** Make sure the wheel rotates freely and that the brake pads are retracted sufficiently to allow free movement of the tire and wheel assembly.

Spin the tire by hand to check the wheel bearings for roughness.

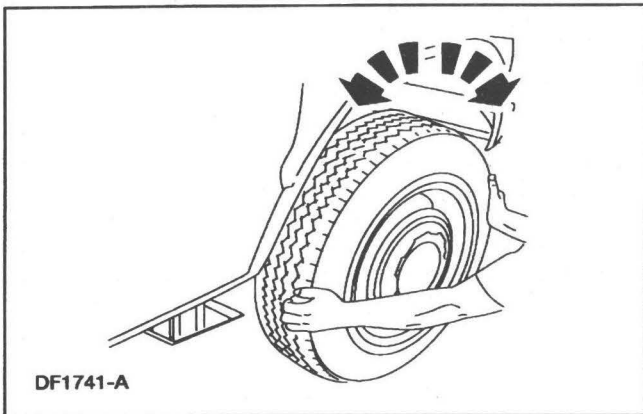

100% SATISFACTION GUARANTEED

BUY IT NOW!

Click Here To Order





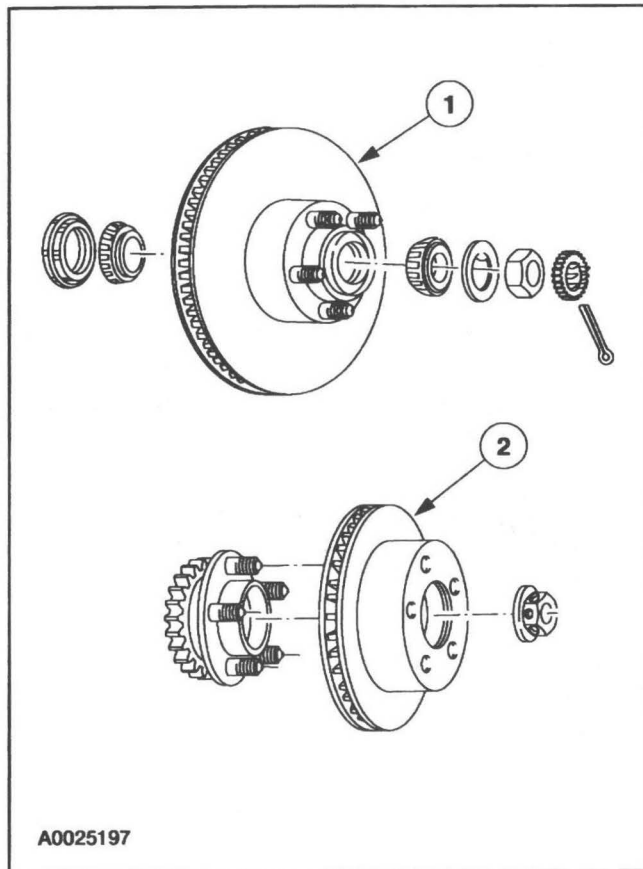
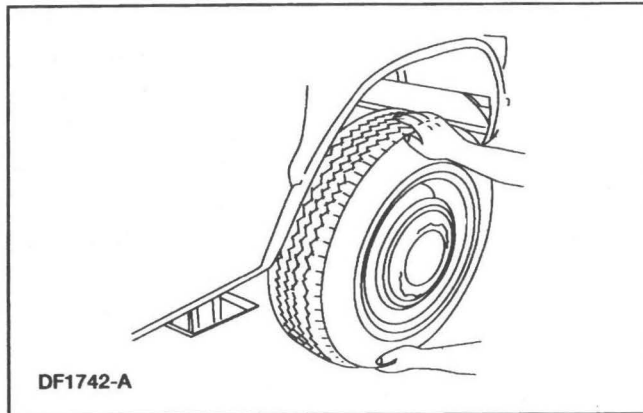

GENERAL PROCEDURES (Continued)

3. Grip each front tire at the top and bottom and move the wheel inward and outward while lifting the weight of the tire off the front wheel bearing.

4. If the tire and wheel (hub) is loose on the spindle, does not rotate freely, or has a rough feeling when spun, carry out one of the following:
 - 1 On vehicles with inner and outer bearings, inspect the bearings and cups for wear or damage. Adjust or install new bearings and cups as necessary.
 - 2 On vehicles with one sealed bearing, install a new wheel hub.



BUY IT NOW!

Click Here To Order



GROUP

Chassis **2**

SECTION TITLE	PAGE
Suspension System — General Information.....	204-00-1
Front Suspension — 4x2	204-01A-1
Front Suspension — 4x4	204-01B-1
Rear Suspension	204-02-1
Wheels and Tires.....	204-04-1
Driveline System — General Information.....	205-00-1
Driveshaft.....	205-01-1
Rear Drive Axle/Differential — Ford 8.8-Inch Ring Gear.....	205-02A-1
Rear Drive Axle/Differential — Ford 9.75-Inch Ring Gear.....	205-02B-1
Rear Drive Axle/Differential — Ford 10.25-Inch Ring Gear.....	205-02C-1
Front Drive Axle/Differential — Ford 8.8-Inch Ring Gear.....	205-03-1
Front Drive Halfshafts	205-04-1
Brake System — General Information	206-00-1
Drum Brake	206-02-1
Front Disc Brake	206-03-1
Rear Disc Brake	206-04-1
Parking Brake and Actuation	206-05-1
Hydraulic Brake Actuation	206-06-1
Power Brake Actuation.....	206-07-1
Anti-Lock Control — Rear	206-09A-1
Anti-Lock Control — 4-Wheel.....	206-09B-1
Steering System — General Information.....	211-00-1
Power Steering.....	211-02-1
Steering Linkage.....	211-03-1
Steering Column	211-04-1
Steering Column Switches.....	211-05-1

SECTION 204-00 Suspension System — General Information

CONTENTS	PAGE
SPECIFICATIONS	204-00-3
DESCRIPTION AND OPERATION	
Wheel Alignment Angles.....	204-00-3
Camber.....	204-00-4
Caster.....	204-00-4
Steering.....	204-00-6
Steering.....	204-00-6
Steering.....	204-00-6
Steering.....	204-00-6



BUY IT NOW!

Click Here To Order



Ford Motor Company

**TECHNICAL
SUPPORT OPERATIONS**
Automotive Consumer Services Group



100% SATISFACTION GUARANTEED

BUY IT NOW!

Click Here To Order

PayPal, American Express Cards, Discover, MasterCard, VISA

LITHO IN U.S.A.
PG-2608



2002 Workshop Manual



License #84356800



F-150

VOLUME 2



BUY IT NOW!

Click Here To Order



Motor Company



2002 F-150

TABLE OF CONTENTS

INTRODUCTION

GENERAL INFORMATION..... Volume 1

SERVICE INFORMATION

Identification Codes.....	100-01
Jacking and Lifting.....	100-02
Noise, Vibration and Harshness.....	100-04

CHASSIS..... Volume 1

SUSPENSION

Suspension System — General Information.....	204-00
Front Suspension — 4x2.....	204-01A
Front Suspension — 4x4.....	204-01B
Rear Suspension.....	204-02
Wheels and Tires.....	204-04

DRIVELINE

Driveline System — General Information.....	205-00
Driveshaft.....	205-01
Rear Drive Axle/Differential — Ford	
8.8-Inch Ring Gear.....	205-02A
Rear Drive Axle/Differential — Ford	
9.75-Inch Ring Gear.....	205-02B
Rear Drive Axle/Differential — Ford	
10.25-Inch Ring Gear.....	205-02C
Front Drive Axle/Differential — Ford	
8.8-Inch Ring Gear.....	205-03
Front Drive Halfshafts.....	205-04

BRAKE SYSTEM

Brake System — General Information.....	206-00
Drum Brake.....	206-02
Front Disc Brake.....	206-03
Rear Disc Brake.....	206-04
Parking Brake and Actuation.....	206-05
Hydraulic Brake Actuation.....	206-06
Power Brake Actuation.....	206-07
Anti-Lock Control — Rear.....	206-09A
Anti-Lock Control — 4-Wheel.....	206-09B

STEERING SYSTEM

Steering System — General Information.....	211-00
Power Steering.....	211-02
Steering Linkage.....	211-03
Steering Column.....	211-04
Steering Column Switches.....	211-05

POWERTRAIN..... Volume 2

ENGINE

Engine System — General Information.....	303-00
Engine — 4.2L.....	303-01A
Engine — 4.6L and 5.4L.....	303-01B
Engine Cooling.....	303-03A
Supercharger Cooling.....	303-03B
Fuel Charging and Controls — 4.2L.....	303-04A
Fuel Charging and Controls —	
4.6L (2V) and 5.4L (2V).....	303-04B
Fuel Charging and Controls —	
Natural Gas Vehicle.....	303-04C
Fuel Charging and Controls —	
Bi-Fuel Vehicles.....	303-04D
Accessory Drive.....	303-05
Starting System.....	303-06
Engine Ignition — 4.2L.....	303-07A
Engine Ignition — 4.6L (2V) and 5.4L (2V).....	303-07B
Engine Emission Control.....	303-08
Intake Air Distribution and Filtering.....	303-12
Evaporative Emissions.....	303-13
Electronic Engine Controls.....	303-14

AUTOMATIC TRANSMISSION

Automatic Transmission — 4R100.....	307-01A
Automatic Transmission — 4R70W.....	307-01B
Transaxle/Transmission Cooling.....	307-02
Automatic Transaxle/Transmission	
External Controls.....	307-05

NOTE: The descriptions and specifications contained in this manual were in effect at the time this manual was approved for printing. Ford Motor Company reserves the right to discontinue models at any time, or change specifications or design without notice and without incurring any obligation.

PUBLICATIONS ORDERING INFORMATION

To obtain information about ordering additional copies of this publication or to order any other Ford or Lincoln/Mercury publications, call 1-800-4-A-FORD. Available publications include workshop manuals, wiring diagrams, PC/ED Manuals and Owner Guides.

form by writing to: Ford Publications, care of Helm Inc., P.O. Box 07150, Detroit, MI 48207.

, electronic or mechanical, including photocopying, recording, or by any information storage and not permitted without written authorization from Ford Motor Company.



2002 F-150

TABLE OF CONTENTS

MANUAL TRANSMISSION, CLUTCH AND TRANSFER CASE

Manual Transaxle/Transmission and Clutch —	
General Information	308-00
Clutch	308-01
Clutch Controls	308-02
Manual Transaxle/Transmission	308-03
Transfer Case — General Information	308-07A
Transfer Case	308-07B

EXHAUST SYSTEM

Exhaust System	309-00
----------------------	--------

FUEL SYSTEM

Fuel System — General Information	310-00A
Fuel System — General Information —	
Natural Gas	310-00B
Fuel System — General Information —	
Bi-Fuel Vehicles	310-00C
Fuel Tank and Lines	310-01A
Fuel Tank and Lines — Natural Gas	310-01B
Fuel Tank and Lines — Bi-Fuel Vehicles	310-01C
Acceleration Control	310-02
Vehicle Speed Control	310-03

ELECTRICAL Volume 1

CLIMATE CONTROL SYSTEM

Climate Control System — General Information	412-00
Air Distribution and Filtering	412-01
Heating and Ventilation	412-02
Air Conditioning	412-03
Control Components	412-04

INSTRUMENTATION AND WARNING SYSTEMS

Instrument Cluster and Panel Illumination	413-00
Instrument Cluster — Conventional	413-01A
Instrument Cluster — Natural Gas Vehicle	413-01B
Instrument Cluster — Bi-Fuel Vehicles	413-01C
Horn	413-06
Warning Devices	413-09

BATTERY AND CHARGING SYSTEM

Charging System — General Information	414-00
Battery, Mounting and Cables	414-01
Generator and Regulator	414-02

AUDIO SYSTEMS

Entertainment System — General Information	415-00
Audio Unit	415-01
Antenna	415-02
Speakers	415-03
Video System	415-07

LIGHTING

Exterior Lighting	417-01
Interior Lighting	417-02
Daytime Running Lamps	417-04

ELECTRICAL DISTRIBUTION

Module Communications Network	418-00
Module Configuration	418-01

ELECTRONIC FEATURE GROUP

Anti-Theft — PATS	419-01
Remote Convenience	419-02
Multifunction Electronic Control Modules	419-10
Electronic Compass	419-11

BODY AND PAINT Volume 1

BODY

Body System — General Information	501-00
Front End Body Panels	501-02
Body Closures	501-03
Pickup Bed and Platform Body	501-04
Interior Trim and Ornamentation	501-05
Exterior Trim and Ornamentation	501-08
Rear View Mirrors	501-09
Seating	501-10
Glass, Frames and Mechanisms	501-11
Instrument Panel and Console	501-12
Handles, Locks, Latches and Entry Systems	501-14
Wipers and Washers	501-16
Roof Opening Panel	501-17
Bumpers	501-19
Occupant Restraints — Active	501-20A
Occupant Restraints — Passive —	
Supplemental Air Bag System	501-20B

FRAME AND MOUNTING

Full Frame and Body Mounting	502-02
------------------------------------	--------

INDEX

100% SATISFACTION GUARANTEED

BUY IT NOW!

Click Here To Order

INTRODUCTION

NOTE: The descriptions and specifications contained in this manual were in effect at the time this manual was approved for printing. Ford Motor Company reserves the right to discontinue models at any time, or change specifications or design without notice and without incurring any obligation.

IMPORTANT SAFETY NOTICE

Appropriate service methods and procedures are essential for the safe, reliable operation of all motor vehicles as well as the personal safety of the individual doing the work. This manual provides general directions for performing service with tested, effective techniques. Following them will help assure reliability.

There are numerous variations in procedure, techniques, tools and parts for servicing vehicles, as well as in the skill of the individual doing the work. This manual cannot possibly anticipate all such variations and provide advice or cautions as to each. Accordingly, anyone who departs from the instructions provided in this manual must first establish that he compromises neither his personal safety nor the vehicle integrity by his choice of methods, tools or parts.

NOTES, CAUTIONS, AND WARNINGS

As you read through the procedures, you will come across **NOTES**, **CAUTIONS**, and **WARNINGS**. Each one is there for a specific purpose. **NOTES** give you added information that will help you to perform a particular procedure. **CAUTIONS** are given to prevent you from making an error that could damage the vehicle. **WARNINGS** remind you to be especially careful in those areas where carelessness can cause you personal injury. The following list contains some general **WARNINGS** that you should follow when you work on a vehicle.

- **ALWAYS WEAR SAFETY GLASSES FOR EYE PROTECTION.**
- **USE SAFETY STANDS WHENEVER A PROCEDURE REQUIRES YOU TO BE UNDER THE VEHICLE.**
- **MAKE SURE THAT THE IGNITION SWITCH IS ALWAYS IN THE OFF POSITION, UNLESS OTHERWISE REQUIRED BY THE PROCEDURE.**
- **SET THE PARKING BRAKE WHEN WORKING ON THE VEHICLE. IF YOU HAVE AN AUTOMATIC TRANSMISSION, SET IN PARK UNLESS INSTRUCTED OTHERWISE FOR A SPECIFIC OPERATION. IF YOU HAVE A MANUAL TRANSMISSION, IT SHOULD BE IN REVERSE (ENGINE OFF) OR NEUTRAL (ENGINE ON) UNLESS INSTRUCTED OTHERWISE FOR A SPECIFIC OPERATION. PLACE WOOD BLOCKS (4" X 4" OR LARGER) AGAINST THE FRONT AND REAR SURFACES OF THE TIRES TO HELP PREVENT THE VEHICLE FROM MOVING.**
- **OPERATE THE ENGINE ONLY IN A WELL-VENTILATED AREA TO AVOID THE DANGER OF CARBON MONOXIDE POISONING.**
- **KEEP YOURSELF AND YOUR CLOTHING AWAY FROM MOVING PARTS WHEN THE ENGINE IS RUNNING, ESPECIALLY THE DRIVE BELTS.**
- **TO PREVENT SERIOUS BURNS, AVOID CONTACT WITH HOT METAL PARTS SUCH AS THE RADIATOR, EXHAUST MANIFOLD, TAIL PIPE, THREE-WAY CATALYTIC CONVERTER AND MUFFLER.**
- **DO NOT SMOKE WHILE WORKING ON A VEHICLE.**
- **TO AVOID INJURY, ALWAYS REMOVE RINGS, WATCHES, LOOSE HANGING JEWELRY AND LOOSE CLOTHING BEFORE BEGINNING TO WORK ON A VEHICLE.**

WHEN IT IS NECESSARY TO WORK UNDER THE HOOD, KEEP HANDS AND OTHER OBJECTS CLEAR OF MOVING PARTS!



BUY IT NOW!

Click Here To Order



GROUP

Powertrain 3

SECTION TITLE	PAGE
Engine System — General Information	303-00-1
Engine — 4.2L	303-01A-1
Engine — 4.6L and 5.4L	303-01B-1
Engine Cooling	303-03A-1
Supercharger Cooling	303-03B-1
Fuel Charging and Controls — 4.2L.....	303-04A-1
Fuel Charging and Controls — 4.6L (2V) and 5.4L (2V).....	303-04B-1
Fuel Charging and Controls — Natural Gas Vehicle	303-04C-1
Fuel Charging and Controls — Bi-Fuel Vehicles.....	303-04D-1
Accessory Drive.....	303-05-1
Starting System	303-06-1
Engine Ignition — 4.2L.....	303-07A-1
Engine Ignition — 4.6L (2V) and 5.4L (2V).....	303-07B-1
Engine Emission Control	303-08-1
Intake Air Distribution and Filtering	303-12-1
Evaporative Emissions	303-13-1
Electronic Engine Controls.....	303-14-1
Automatic Transmission — 4R100	307-01A-1
Automatic Transmission — 4R70W	307-01B-1
Transaxle/Transmission Cooling.....	307-02-1
Automatic Transaxle/Transmission External Controls	307-05-1
Manual Transaxle/Transmission and Clutch — General Information.....	308-00-1
Clutch	308-01-1
Clutch Controls.....	308-02-1
Manual Transaxle/Transmission.....	308-03-1
Transfer Case — General Information	308-07A-1
Transfer Case	308-07B-1
Exhaust System	309-00-1
Fuel System — General Information.....	310-00A-1
Fuel System — General Information — Natural Gas.....	310-00B-1
Fuel System — General Information — Bi-Fuel Vehicles	310-00C-1
Fuel Tank and Lines	310-01A-1
Fuel Tank and Lines — Natural Gas	310-01B-1
Fuel Tank and Lines — Bi-Fuel Vehicles.....	310-01C-1
Acceleration Control	310-02-1
Vehicle Speed Control	310-03-1

SECTION 303-00 Engine System — General Information

100% SATISFACTION GUARANTEED

BUY IT NOW!

Click Here To Order

PAGE

.....303-00-4

CONTENTS	PAGE
DESCRIPTION AND OPERATION	
Engine	303-00-4
DIAGNOSIS AND TESTING	
Engine	303-00-5
Component Tests	303-00-9
Compression Test—Compression Gauge Check	303-00-10
Cylinder Leakage Detection	303-00-11
Excessive Engine Oil Consumption	303-00-14
Inspection and Verification	303-00-5
Intake Manifold Vacuum Test	303-00-13
Oil Consumption Test	303-00-11
Symptom Chart	303-00-6
Valve Train Analysis—Engine Off—Valve Cover Removed	303-00-15
Valve Train Analysis—Engine Running	303-00-15
GENERAL PROCEDURES	
Bearing — Inspection	303-00-48
Camshaft — Lobe Surface	303-00-23
Camshaft End Play — OHC Engines	303-00-22
Camshaft End Play — Push Rod Engines	303-00-21
Camshaft Journal — Clearance, Plastigage Method	303-00-21
Camshaft Journal — Clearance, Push Rod Engines, Micrometer Method	303-00-20
Camshaft Journal — Diameter	303-00-20
Camshaft Lobe Lift	303-00-23
Camshaft Runout	303-00-24
Connecting Rod — Bearing Journal Clearance	303-00-35
Connecting Rod — Bend	303-00-34
Connecting Rod — Bushing Diameter	303-00-34
Connecting Rod — Cleaning	303-00-33
Connecting Rod — Large End Bore	303-00-33
Connecting Rod — Piston Pin Side Clearance	303-00-35
Connecting Rod — Side Clearance	303-00-36
Connecting Rod — Twist	303-00-34
Crankshaft — Connecting Rod Journal Taper, Out of Round	303-00-27
Crankshaft End Play	303-00-26
Crankshaft Main Bearing Journal — Clearance	303-00-25
Crankshaft Main Bearing Journal — Diameter	303-00-24
Crankshaft Main Bearing Journal — Taper	303-00-25
Crankshaft Runout	303-00-27
Cylinder Block Core Plug Replacement	303-00-44
Cylinder Bore — Cleaning	303-00-43
Cylinder Bore — Out-of-Round	303-00-28
Cylinder Bore — Taper	303-00-28
Cylinder Head — Distortion	303-00-43
Exhaust Manifold — Inspection	303-00-47
.....	303-00-30
.....	303-00-33
.....	303-00-29
.....	303-00-31



BUY IT NOW!

Click Here To Order



CONTENTS

PAGE

Piston — Ring-to-Groove Clearance.....	303-00-32
Piston — Selection.....	303-00-31
Piston — to Cylinder Bore Clearance	303-00-30
Piston Inspection	303-00-28
Push Rods — Cleaning	303-00-19
Push Rods — Inspection.....	303-00-19
Rocker Arms — Cleaning.....	303-00-18
Rocker Arms — Inspection	303-00-19
Roller Follower — Inspection	303-00-36
Spark Plug — Inspection.....	303-00-45
Spark Plug Hole Thread Repair.....	303-00-45
Sprockets	303-00-18
Valve — Guide Inner Diameter	303-00-39
Valve — Guide Reaming	303-00-40
Valve — Inspection	303-00-39
Valve — Seat Inspection	303-00-42
Valve — Seat Runout	303-00-43
Valve — Seat Width	303-00-42
Valve — Spring Free Length	303-00-40
Valve — Spring Installed Length	303-00-40
Valve — Spring Squareness	303-00-41
Valve — Stem Diameter	303-00-38
Valve — Stem to Valve Guide Clearance.....	303-00-38
Valve Spring Strength	303-00-41
Valve Tappet — Inspection.....	303-00-37



BUY IT NOW!

Click Here To Order

PayPal

Discover
Cards

DISCOVER
NEW! VISA

MasterCard

VISA

SPECIFICATIONS

General Specifications

Item	Specification
Threadlock® 262 E2FZ-19554-B	WSK-M2G351-A6
Lubricants	
Super Premium SAE Motor Oil	Refer to owner literature
Diesel engine oil	Refer to owner literature
Gasoline Engine Oil Dye 164-R3705	ESE-M99C103-B1

DESCRIPTION AND OPERATION

Engine

NOTE: This section contains information, steps and procedures that may not be specific to your engine.

This section covers general procedures and diagnosis and testing of the engine system, except for exhaust emission control devices, which are covered in the Powertrain Control/Emissions Diagnosis Manual.

The engine incorporates the following features:

- a closed positive crankcase ventilation (PCV) system. For additional information, refer to Section 303-08.
- an exhaust emission control system. For additional information, refer to Section 303-08.
- an evaporative emission control system. For additional information, refer to Section 303-13.

Some engines incorporate a fail-safe cooling system. Refer to the appropriate section in Group 303 for the procedure.

The engine, fuel system, ignition system, emissions system and exhaust system all affect exhaust emission levels and must be maintained according to the maintenance schedule. Refer to the scheduled Maintenance Guide.







Correct engine identification is required to order parts. Refer to the appropriate section in Group 303 for the procedure.

For complete vehicle and engine identification codes, refer to Section 100-01.

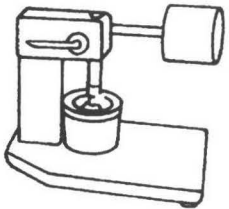
DIAGNOSIS AND TESTING

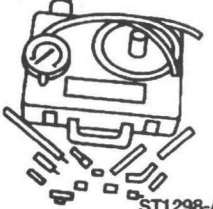

Engine

Special Tool(s)

	Commercially Available Leakdown Tester —
	Quick Disconnect Compression Tester 134-R0212 or equivalent
	Dial Indicator Gauge Adapter 303-007 (TOOL-6565-AB) or equivalent
	Dial Indicator Gauge with Holding Fixture 100-002 (TOOL-4201-C) or equivalent
	Engine Cylinder Leak Detection/Air Pressurization Kit 014-00708 or equivalent
	Oil Pressure Gauge 303-088 (T73L-6600-A)

(Continued)

Special Tool(s)

	UV Leak Detector Kit 164-R0756 or equivalent
	Vacuum/Pressure Tester 164-R0253 or equivalent

Materials

Item	Specification
Gasoline Engine Oil Dye 164-R3705 or equivalent	ESE-M99C103-B1
Engine Oil	Refer to owner literature

Inspection and Verification

1. Verify the customer concern by operating the engine to duplicate the condition.
2. Visually inspect for obvious signs of mechanical damage. Refer to the following chart.

Visual Inspection Chart

Mechanical
<ul style="list-style-type: none"> • Engine coolant leaks • Engine oil leaks • Fuel leaks • Damaged or severely worn parts • Loose mounting bolts, studs and nuts

3. If the inspection reveals obvious concerns that can be readily identified, repair as necessary.
4. If the concerns remain after the inspection, determine the symptoms and go to the Symptom Chart.



BUY IT NOW!

Click Here To Order



DIAGNOSIS AND TESTING (Continued)**Symptom Chart****Symptom Chart**

Condition	Possible Sources	Action
<ul style="list-style-type: none"> • Difficult starting 	<ul style="list-style-type: none"> • Damaged ignition system. • Damaged fuel system. • Damaged starting system. • Damaged charging system/battery. • Burnt valve. • Worn piston. • Worn piston rings. • Worn cylinder. • Damaged head gasket. • Damaged cooling system. 	<ul style="list-style-type: none"> • Refer to the appropriate section in Group 303 for the procedure. REFER to the Powertrain Control/Emissions Diagnosis (PC/ED) manual ¹. • Refer to the appropriate section in Group 303 for the procedure. REFER to the Powertrain Control/Emissions Diagnosis (PC/ED) manual ¹. • Refer to the appropriate section in Group 303 for the procedure. REFER to the Powertrain Control/Emissions Diagnosis (PC/ED) manual ¹. • REFER to Section 414-00. • INSTALL a new valve. • INSTALL a new piston. • INSTALL new piston rings. • REPAIR or INSTALL a new cylinder block. • INSTALL a new head gasket. • Refer to the appropriate section in Group 303 for the procedure. REFER to the Powertrain Control/Emissions Diagnosis (PC/ED) manual ¹.
<ul style="list-style-type: none"> • Poor idling 	<ul style="list-style-type: none"> • Vacuum leaks. • Malfunctioning or damaged ignition system. • Malfunctioning or damaged fuel system. • Damaged valve tappet or lash adjuster. • Damaged valve tappet guide or lash adjuster. • Incorrect valve-to-valve seat contact. • Damaged head gasket. 	<ul style="list-style-type: none"> • Refer to the appropriate section in Group 303 for the procedure. REFER to the Powertrain Control/Emissions Diagnosis (PC/ED) manual ¹. • Refer to the appropriate section in Group 303 for the procedure. REFER to the Powertrain Control/Emissions Diagnosis (PC/ED) manual ¹. • Refer to the appropriate section in Group 303 for the procedure. REFER to the Powertrain Control/Emissions Diagnosis (PC/ED) manual ¹. • INSTALL a new valve tappet or lash adjuster. • INSTALL a new valve tappet guide or valve tappet. • REPAIR or INSTALL a new valve or valve seat. • INSTALL a new head gasket.



BUY IT NOW!

Click Here To Order



DIAGNOSIS AND TESTING (Continued)**Symptom Chart (Continued)**

Condition	Possible Sources	Action
<ul style="list-style-type: none"> Abnormal combustion 	<ul style="list-style-type: none"> Malfunctioning or damaged fuel system. Malfunctioning or damaged ignition system. Malfunctioning or damaged air intake system. Damaged valve tappet or lash adjuster. Damaged valve tappet guide or valve tappet. Burnt or sticking valve. Weak or broken valve spring. Carbon accumulation in combustion chamber. 	<ul style="list-style-type: none"> Refer to the appropriate section in Group 303 for the procedure. REFER to the Powertrain Control/Emissions Diagnosis (PC/ED) manual ². Refer to the appropriate section in Group 303 for the procedure. REFER to the Powertrain Control/Emissions Diagnosis (PC/ED) manual ². Refer to the appropriate section in Group 303 for the procedure. REFER to the Powertrain Control/Emissions Diagnosis (PC/ED) manual ². INSTALL a new valve tappet or lash adjuster. INSTALL a new valve tappet guide or valve tappet. REPAIR or INSTALL a new valve. INSTALL a new valve spring. ELIMINATE carbon buildup.
<ul style="list-style-type: none"> Excessive oil consumption 	<ul style="list-style-type: none"> Leaking oil. Malfunctioning PCV system. Worn valve stem seal. Worn valve stem or valve guide. Sticking piston rings. Worn piston ring groove. Worn piston or cylinder. 	<ul style="list-style-type: none"> REPAIR oil leakage. REPAIR or INSTALL new necessary components. INSTALL a new valve stem seal. INSTALL a new valve and valve guide. REPAIR or INSTALL new piston rings. INSTALL a new piston and piston pin. REPAIR or INSTALL a new piston or cylinder block.



100% SATISFACTION GUARANTEED

BUY IT NOW!

Click Here To Order

PayPal American Express Discover MasterCard VISA

DIAGNOSIS AND TESTING (Continued)**Symptom Chart (Continued)**

Condition	Possible Sources	Action
<ul style="list-style-type: none"> • Engine noise 	<ul style="list-style-type: none"> • Leaking exhaust system. • Incorrect drive belt tension. • Malfunctioning generator bearing. • Malfunctioning water pump bearing. • Malfunctioning or damaged cooling system. • Malfunctioning or damaged fuel system. • Loose timing chain/belt (6268). • Damaged timing chain tensioner (6L266). • Excessive main bearing clearance. • Seized or heat damaged crankshaft main bearing. • Excessive crankshaft end play. • Excessive connecting rod bearing clearance. • Heat damaged connecting rod bearing (6211). • Damaged connecting rod bushing (6207). • Worn cylinder. • Worn piston (6108) or piston pin (6135). • Damaged piston rings. • Bent connecting rod. • Malfunctioning valve tappet (6500) or lash adjuster. • Excessive valve tappet or lash adjuster clearance. • Broken valve spring (6513). • Excessive valve guide clearance. 	<ul style="list-style-type: none"> • REPAIR exhaust leakage. • REFER to Section 303-05. • Refer to the appropriate section in Group 414 for the procedure. • REFER to Section 303-03A. • REFER to Section 303-03A. • Refer to the appropriate section in Group 303 for the procedure. REFER to the Powertrain Control/Emissions Diagnosis (PC/ED) manual ³. • ADJUST or INSTALL a new timing chain/belt. • INSTALL a new timing chain tensioner. • ADJUST clearance or INSTALL a new crankshaft main bearing (6333). • INSTALL a new crankshaft main bearing. • INSTALL a new thrust bearing or crankshaft (6303). • INSTALL a new connecting rod bearing or connecting rod (6200). • INSTALL a new connecting rod bearing. • INSTALL a new connecting rod bushing. • REPAIR or INSTALL a new cylinder block (6010). • INSTALL a new piston or piston pin. • INSTALL new piston rings. • INSTALL a new connecting rod. • INSTALL a new valve tappet or lash adjuster. • ADJUST clearance or INSTALL a new valve tappet guide or valve tappet. • INSTALL a new valve spring. • ADJUST clearance or INSTALL a new valve guide (6510) or valve.



BUY IT NOW!

Click Here To Order

Can be purchased as a separate item



DIAGNOSIS AND TESTING (Continued)**Symptom Chart (Continued)**

Condition	Possible Sources	Action
<ul style="list-style-type: none"> Insufficient power 	<ul style="list-style-type: none"> Malfunctioning or damaged ignition system. Malfunctioning or damaged fuel system. Malfunctioning or damaged air intake system. Damaged or plugged exhaust system. Incorrect tire size. Dragging brakes. Slipping transmission. Malfunctioning valve tappet or lash adjuster. Damaged valve tappet guide or valve tappet. Compression leakage at valve seat. Seized valve stem. Weak or broken valve spring. Worn or damaged camshaft. Damaged head gasket (6051). Cracked or distorted cylinder head. Damaged, worn or sticking piston ring(s). Worn or damaged piston. 	<ul style="list-style-type: none"> Refer to the appropriate section in Group 303 for the procedure. REFER to the Powertrain Control/Emissions Diagnosis (PC/ED) manual ⁴. Refer to the appropriate section in Group 303 for the procedure. REFER to the Powertrain Control/Emissions Diagnosis (PC/ED) manual ⁴. Refer to the appropriate section in Group 303 for the procedure. REFER to the Powertrain Control/Emissions Diagnosis (PC/ED) manual ⁴. INSPECT exhaust system. REFER to Section 204-04. REFER to Section 206-00. Refer to the appropriate section in Group 307 for the procedure. INSTALL a new valve tappet or lash adjuster. INSTALL a new valve tappet guide or valve tappet. REPAIR or INSTALL a new valve, valve seat or cylinder head (6049). INSTALL a new valve. INSTALL a new valve spring. INSTALL a new camshaft. INSTALL a new head gasket. INSTALL a new cylinder head. REPAIR or INSTALL a new piston ring(s). INSTALL a new piston and piston pin.

Component Tests**Engine Oil Leaks**

NOTE: When diagnosing engine oil leaks, the source and location of the leak must be positively identified prior to repair.

Prior to carrying out this procedure, clean all sealing surface areas with a suitable solvent to remove all traces of oil.

Engine Oil Leaks—Fluorescent Oil Additive method

- Add gasoline engine oil dye. Use a minimum 14.8 ml (0.5 ounce) to a maximum 29.6 ml (1 ounce) of fluorescent additive to all engines. If the oil is not premixed, fluorescent additive must first be added to crankcase.
- Run the engine for 15 minutes. Stop the engine and inspect all seal and gasket areas for leaks using the UV Leak Detector Kit. A clear bright yellow or orange area will identify the leak. For extremely small leaks, several hours may be required for the leak to appear.

carry out the diagnosis.



BUY IT NOW!

Click Here To Order



DIAGNOSIS AND TESTING (Continued)

Leakage Points—Underhood

Examine the following areas for oil leakage:

- valve cover gaskets
- intake manifold gaskets
- cylinder head gaskets
- oil bypass filter
- oil filter adapter
- engine front cover
- oil filter adapter and filter body
- oil level indicator tube connection
- oil pressure sensor

Leakage Points—Under Engine—With Vehicle on Hoist

- oil pan gaskets (6710)
- oil pan sealer
- oil pan rear seal (6723)
- engine front cover gasket
- crankshaft front seal (6700)
- crankshaft rear oil seal (6701)
- crankshaft main bearing cap side bolts
- oil filter adapter and filter body
- oil cooler, if equipped

Leakage Points—With Transmission and Flywheel Removed

- crankshaft rear oil seal
- rear main bearing cap parting line
- rear main bearing cap and seals

- flywheel mounting bolt holes (with flywheel installed)
- camshaft rear bearing covers (6266) or pipe plugs at the end of oil passages

Oil leaks at crimped seams in sheet metal parts and cracks in cast or stamped parts can be detected when using the dye method.

Compression Test—Compression Gauge Check

1. Make sure the oil in the crankcase is of the correct viscosity and at the correct level and that the battery (10655) is correctly charged. Operate the vehicle until the engine is at normal operating temperature. Turn the ignition switch to the OFF position, then remove all the spark plugs (12405).
2. Set the throttle plates in the wide-open position.
3. Install a compression gauge such as the Compression Tester in the No. 1 cylinder.
4. Install an auxiliary starter switch in the starting circuit. With the ignition switch in the OFF position, and using the auxiliary starter switch, crank the engine a minimum of five compression strokes and record the highest reading. Note the approximate number of compression strokes required to obtain the highest reading.
5. Repeat the test on each cylinder, cranking the engine approximately the same number of compression strokes.

Compression Test—Test Results

The indicated compression pressures are considered within specification if the lowest reading cylinder is within 75 percent of the highest reading. Refer to the Compression Pressure Limit Chart.

Compression Pressure Limit Chart

Maximum Pressure	Minimum Pressure	Maximum Pressure	Minimum Pressure	Maximum Pressure	Minimum Pressure	Maximum Pressure	Minimum Pressure
924 kPa (134 psi)	696 kPa (101 psi)	1131 kPa (164 psi)	848 kPa (123 psi)	1338 kPa (194 psi)	1000 kPa (146 psi)	1544 kPa (224 psi)	1158 kPa (168 psi)
938 kPa (136 psi)	703 kPa (102 psi)	1145 kPa (166 psi)	855 kPa (124 psi)	1351 kPa (196 psi)	1014 kPa (147 psi)	1558 kPa (226 psi)	1165 kPa (169 psi)
952 kPa (138 psi)	717 kPa (104 psi)	1158 kPa (168 psi)	869 kPa (126 psi)	1365 kPa (198 psi)	1020 kPa (148 psi)	1572 kPa (228 psi)	1179 kPa (171 psi)
966 kPa (140 psi)	724 kPa (106 psi)	1172 kPa (170 psi)	876 kPa (127 psi)	1379 kPa (200 psi)	1034 kPa (150 psi)	1586 kPa (230 psi)	1186 kPa (172 psi)
980 kPa (142 psi)	731 kPa (107 psi)	1186 kPa (172 psi)	889 kPa (129 psi)	1393 kPa (202 psi)	1041 kPa (151 psi)	1600 kPa (232 psi)	1200 kPa (174 psi)



BUY IT NOW!

Click Here To Order



DIAGNOSIS AND TESTING (Continued)**Compression Pressure Limit Chart**

Maximum Pressure	Minimum Pressure	Maximum Pressure	Minimum Pressure	Maximum Pressure	Minimum Pressure	Maximum Pressure	Minimum Pressure
933 kPa (144 psi)	745 kPa (109 psi)	1200 kPa (174 psi)	903 kPa (131 psi)	1407 kPa (204 psi)	1055 kPa (153 psi)	1055 kPa (153 psi)	1207 kPa (175 psi)
1007 kPa (146 psi)	758 kPa (110 psi)	1214 kPa (176 psi)	910 kPa (132 psi)	1420 kPa (206 psi)	1062 kPa (154 psi)	1627 kPa (154 psi)	1220 kPa (177 psi)
1020 kPa (148 psi)	765 kPa (111 psi)	1227 kPa (178 psi)	917 kPa (133 psi)	1434 kPa (208 psi)	1075 kPa (156 psi)	1641 kPa (238 psi)	1227 kPa (178 psi)
1034 kPa (150 psi)	779 kPa (113 psi)	1241 kPa (180 psi)	931 kPa (135 psi)	1448 kPa (210 psi)	1083 kPa (157 psi)	1655 kPa (240 psi)	1241 kPa (180 psi)
1048 kPa (152 psi)	786 kPa (114 psi)	1255 kPa (182 psi)	936 kPa (136 psi)	1462 kPa (212 psi)	1089 kPa (158 psi)	1669 kPa (242 psi)	1248 kPa (181 psi)
1062 kPa (154 psi)	793 kPa (115 psi)	1269 kPa (184 psi)	952 kPa (138 psi)	1476 kPa (214 psi)	1103 kPa (160 psi)	1682 kPa (244 psi)	1262 kPa (183 psi)
1076 kPa (156 psi)	807 kPa (117 psi)	1282 kPa (186 psi)	965 kPa (140 psi)	1489 kPa (216 psi)	1117 kPa (162 psi)	1696 kPa (246 psi)	1269 kPa (184 psi)
1089 kPa (158 psi)	814 kPa (118 psi)	1296 kPa (188 psi)	972 kPa (141 psi)	1503 kPa (218 psi)	1124 kPa (163 psi)	1710 kPa (248 psi)	1202 kPa (186 psi)
1103 kPa (160 psi)	827 kPa (120 psi)	1310 kPa (190 psi)	979 kPa (142 psi)	1517 kPa (220 psi)	1138 kPa (165 psi)	1724 kPa (250 psi)	1289 kPa (187 psi)
1110 kPa (161 psi)	834 kPa (121 psi)	1324 kPa (192 psi)	993 kPa (144 psi)	1631 kPa (222 psi)	1145 kPa (166 psi)	—	—

If one or more cylinders reads low, squirt approximately one tablespoon of engine oil on top of the pistons in the low-reading cylinders. Repeat the compression pressure check on these cylinders.

Compression Test—Interpreting Compression Readings

1. If compression improves considerably, piston rings are faulty.
2. If compression does not improve, valves are sticking or seating incorrectly.
3. If two adjacent cylinders indicate low compression pressures and squirting oil on each piston does not increase compression, the head gasket may be leaking between cylinders. Engine oil or coolant in cylinders could result from this condition.

Use the Compression Pressure Limit Chart when checking cylinder compression so that the lowest reading is within 75 percent of the highest reading.

Cylinder Leakage Detection

When a cylinder produces a low reading, use of the **Cylinder Leakage Detector/Air Pressurization Kit** can help determine the exact cause.

The leakage detector is inserted in the spark plug hole, the piston is brought up to dead center on the compression stroke, and compressed air is admitted.

Once the combustion chamber is pressurized, a special gauge included in the kit will read the percentage of leakage. Leakage exceeding 20 percent is excessive.

While the air pressure is retained in the cylinder, listen for the hiss of escaping air. A leak at the intake valve (6507) will be heard in the throttle body (9E926). A leak at the exhaust valve (6505) can be heard at the tail pipe. Leakage past the piston rings will be audible at the positive crankcase ventilation (PCV) connection. If air is passing through a blown head gasket to an adjacent cylinder, the noise will be evident at the spark plug hole of the cylinder into which the air is leaking. Cracks in the cylinder block or gasket leakage into the cooling system may be detected by a stream of bubbles in the radiator (8005).

Oil Consumption Test

The following diagnostic procedure is used to determine the source of excessive internal oil consumption.



BUY IT NOW!

Click Here To Order



DIAGNOSIS AND TESTING (Continued)

1. **NOTE:** Oil use is normally greater during the first 16,100 km (10,000 miles) of service. As mileage increases, oil use generally decreases. Vehicles in normal service should get at least 1,450 km per liter (900 miles per quart) after 16,000 km (10,000 miles) of service. High speed driving, towing, high ambient temperature and other factors may result in greater oil use.

Define excessive oil consumption, such as the number of miles driven per liter (quart) of oil used. Also determine customer's driving habits, such as sustained high speed operation, towing, extended idle and other considerations.

2. Verify that the engine has no external oil leak as described under Engine Oil Leaks in the Diagnosis and Testing portion of this section.
3. Verify that the engine has the correct oil level dipstick (6750).
4. Verify that the engine is not being run in an overfilled condition. Check the oil level at least five minutes after a hot shutdown with the vehicle parked on a level surface. In no case should the level be above MAX or the letter F in FULL. If significantly overfilled, carry out Steps 6a through 6d.
5. Verify the spark plugs are not oil saturated. If the spark plugs are oil saturated and compression is good it can be assumed the valve seals or valve guides are at fault.
6. Carry out an oil consumption test:
 - a. Drain the engine oil, remove the oil bypass filter (6714) and refill with one liter (quart) less than the recommended amount.
 - b. Run the engine for three minutes (10 minutes if cold), and allow the oil to drain back for at least five minutes with the vehicle on a level surface.
 - c. Remove oil level dipstick and wipe clean. (Do not wipe with anything contaminated with silicone compounds.) Reinstall the oil level dipstick, being sure to seat it firmly in the oil level indicator tube (6754). Remove the oil level dipstick and draw a mark on the back (unmarked) surface at the indicated oil level. This level should be about the same as

- d. Add one liter (quart) of oil. Restart the engine and allow to idle for at least two minutes. Shut off the engine and allow the oil to drain back for at least five minutes. Mark the oil level dipstick, using the procedure above.
 - e. Record the vehicle mileage.
 - f. Instruct the customer to drive the vehicle as usual and perform the following:
 - Check the oil level regularly at intervals of 160 to 240 km (100-150 miles).
 - Return to the service point when the oil level drops below the lower (MIN or ADD) mark on the oil level dipstick.
 - Add only full liters (quarts) of the same oil in an emergency. Note the mileage at which the oil is added.
 - g. Check the oil level under the same conditions and at the same location as in Steps 6c and 6d.
 - Measure the distance from the oil level to the UPPER mark on the oil level dipstick and record.
 - Measure the distance between the two scribe marks and record.
 - Divide the first measurement by the second.
 - Divide the distance driven during the oil test by the result. This quantity is the approximate oil consumption rate in kilometers per liter or in miles per quart.
 - h. If the oil consumption rate is unacceptable, go to Step 7.
7. Check the positive crankcase ventilation (PCV) system. Make sure the system is not plugged.
 8. Check for plugged oil drain-back holes in the cylinder heads and cylinder block.
 9. If the condition still exists after performing the above steps, go to Step 10.
 10. Perform a cylinder compression test or perform a cylinder leak detection test with Engine Cylinder Leak Detection/Air Pressurization Kit. This can help determine the source of oil consumption such as valves, piston rings or other areas.



BUY IT NOW!

Click Here To Order



DIAGNOSIS AND TESTING (Continued)

11. **NOTE:** After determining if new parts should be installed, make sure correct parts are used.

Check valve guides for excessive guide clearance. Install new all valve stem seals (6571) after verifying valve guide clearance.

12. Worn or damaged internal engine components can cause excessive oil consumption. Small deposits of oil on the tips of spark plugs can be a clue to internal oil consumption. If internal oil consumption still persists, proceed as follows:
- Remove the engine from the vehicle and place it on an engine work stand. Remove the intake manifolds (9424), cylinder heads, oil pan (6675) and oil pump (6600).
 - Check piston ring clearance, ring gap and ring orientation. Repair as necessary.
 - Check for excessive bearing clearance. Repair as necessary.
13. Repeat the oil consumption test (Step 6) to confirm the oil consumption concern has been resolved.

Intake Manifold Vacuum Test

Bring the engine to normal operating temperature. Connect the Vacuum/Pressure Tester to the intake manifold. Run the engine at the specified idle speed.

The vacuum gauge should read between 51-74 kPa (15-22 in-Hg) depending upon the engine condition and the altitude at which the test is performed. Subtract 4.0193 kPa (1 in-Hg) from the specified reading for every 304.8 m (1,000 feet) of elevation above sea level.

The reading should be steady. If necessary, adjust the gauge damper control (where used) if the needle is fluttering rapidly. Adjust the damper until the needle moves easily without excessive flutter.

Intake Manifold Vacuum Test—Interpreting Vacuum Gauge Readings

A careful study of the vacuum gauge reading while the engine is idling will help pinpoint trouble areas. Always conduct other appropriate tests before arriving at a final diagnostic decision. Vacuum gauge readings, although helpful, must be interpreted carefully.

Most vacuum gauges have a normal band indicated on

readings. Some are
ed further.

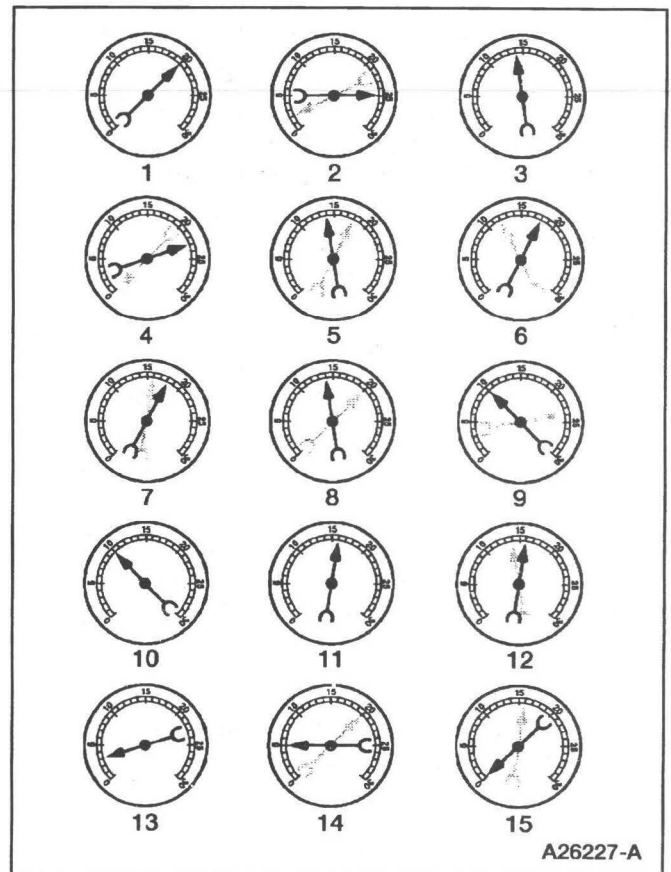

- NORMAL READING:** Needle between 51-74 kPa (15-22 in-Hg) and holding steady.
- NORMAL READING DURING RAPID ACCELERATION AND DECELERATION:** When the engine is rapidly accelerated (dotted needle), the needle will drop to a low reading (not to zero). When the throttle is suddenly released, the needle will snap back up to a higher than normal figure.
- NORMAL FOR HIGH-LIFT CAMSHAFT WITH LARGE OVERLAP:** The needle will register as low as 51 kPa (15 in-Hg) but will be relatively steady. Some oscillation is normal.
- WORN RINGS OR DILUTED OIL:** When the engine is accelerated (dotted needle), the needle drops to 0 kPa (0 in-Hg). Upon deceleration, the needle runs slightly above 74 kPa (22 in-Hg).
- STICKING VALVES:** When the needle (dotted) remains steady at a normal vacuum but occasionally flicks (sharp, fast movement) down and back about 13 kPa (4 in-Hg), one or more valves may be sticking.



BUY IT NOW!

Click Here To Order



DIAGNOSIS AND TESTING (Continued)

6. **BURNED OR WARPED VALVES:** A regular, evenly-spaced, downscale flicking of the needle indicates one or more burned or warped valves. Insufficient hydraulic lash adjuster or hydraulic lash adjuster (HLA) clearance will also cause this reaction.
7. **POOR VALVE SEATING:** A small but regular downscale flicking can mean one or more valves are not seating.
8. **WORN VALVE GUIDES:** When the needle oscillates over about a 13 kPa (4 in-Hg) range at idle speed, the valve guides could be worn. As engine speed increases, the needle will become steady if guides are responsible.
9. **WEAK VALVE SPRINGS:** When the needle oscillation becomes more violent as engine rpm is increased, weak valve springs are indicated. The reading at idle could be relatively steady.
10. **LATE VALVE TIMING:** A steady but low reading could be caused by late valve timing.
11. **IGNITION TIMING RETARDING:** Retarded ignition timing will produce a steady but somewhat low reading.
12. **INSUFFICIENT SPARK PLUG GAP:** When spark plugs are gapped too close, a regular, small pulsation of the needle can occur.
13. **INTAKE LEAK:** A low, steady reading can be caused by an intake manifold or throttle body gasket leak.
14. **BLOWN HEAD GASKET:** A regular drop of fair magnitude can be caused by a blown head gasket or warped cylinder head-to-cylinder block surface.
15. **RESTRICTED EXHAUST SYSTEM:** When the engine is first started and is idled, the reading may be normal, but as the engine rpm is increased, the back pressure caused by a clogged muffler (5230), kinked tail pipe or other concerns will cause the needle to slowly drop to 0 kPa (0 in-Hg). The needle then may slowly rise. Excessive exhaust clogging will cause the needle to drop to a low point even if the engine is only idling.
16. When vacuum leaks are indicated, search out and correct the cause. Excess air leaking into the system will upset the fuel mixture and cause symptoms such as rough idle, missing on a lean mixture, a vacuum leak exists in the brake booster or master cylinder, or the system does not operate correctly.

Excessive Engine Oil Consumption

The amount of oil an engine uses will vary with the way the vehicle is driven in addition to normal engine-to-engine variation. This is especially true during the first 16,100 km (10,000 miles) when a new engine is being broken in or until certain internal engine components become conditioned. Vehicles used in heavy-duty operation may use more oil. The following are examples of heavy-duty operation:

- trailer towing applications
- severe loading applications
- sustained high speed operation

Engines need oil to lubricate the following internal components:

- cylinder block cylinder walls
- pistons and piston, pin and rings (6102)
- intake and exhaust valve stems
- intake and exhaust valve guides
- all internal engine components

When the pistons move downward, a thin film of oil is left on the cylinder walls. As the vehicle is operated, some oil is also drawn into the combustion chambers past the intake and exhaust valve stem seals and burned.

The following is a partial list of conditions that can affect oil consumption rates:

- engine duty cycle
- operator driving habits
- ambient temperature
- quality and viscosity of the oil

Operation under varying conditions can frequently be misleading. A vehicle that has been run for several thousand miles on short trips or in below-freezing ambient temperatures may have consumed a “normal” amount of oil. However, when checking the engine oil level, it may measure up to the FULL or MAX on the oil level dipstick due to dilution (condensation and fuel) in the engine crankcase. The vehicle might then be driven at high speeds on the highway where the condensation and fuel boil off. The next time the engine oil is checked, it may appear that a liter (quart) of oil was used in about 160 km (100 miles). This perceived 160 km (100 miles) per liter (quart) oil consumption rate causes customer concern even though the actual overall oil consumption rate is about 2,400 km (1,500 miles) per liter (quart).



BUY IT NOW!

Click Here To Order



DIAGNOSIS AND TESTING (Continued)

Make sure the selected engine oil meets the current recommended API performance category with SAE viscosity grade as shown in the vehicle Owner's Guide. It is also important that the engine oil is changed at the intervals specified. Refer to the vehicle Owner's Guide.

Oil Pressure Test

1. Disconnect and remove the oil pressure sensor (9278) from the engine.
2. Connect the Oil Pressure Gauge to the oil pressure sender oil galley port.
3. Run the engine until normal operating temperature is reached.
4. Run the engine at the specified rpm and record the gauge reading.
5. The oil pressure should be within specifications; refer to the specification chart in the appropriate engine section.
6. If the pressure is not within specification, check the following possible sources:
 - insufficient oil
 - oil leakage
 - worn or damaged oil pump
 - oil pump screen cover and tube (6622)
 - excessive main bearing clearance
 - excessive connecting rod bearing clearance

Valve Train Analysis—Engine Off—Valve Cover Removed

Check for damaged or severely worn parts and correct assembly. Make sure correct parts are used with the static engine analysis as follows.

Valve Train Analysis—Engine Off, Rocker Arm

- Check for loose mounting bolts, studs and nuts.
- Check for plugged oil feed in the rocker arms (6564) or cylinder head.

Valve Train Analysis—Engine Off, Camshaft Roller Followers and Hydraulic Lash Adjusters, Overhead Camshaft

- Check for loose mounting bolts on camshaft carriers.
- Check for plugged oil feed in the camshaft roller followers and cylinder heads.

Valve Train Analysis—Engine Off, Camshaft—Engines

- Check for broken or damaged parts.

Valve Train Analysis—Engine Off, Push Rods

- Check for bent push rods (6565) and restricted oil passage.

Valve Train Analysis—Valve Springs

- Check for broken or damaged parts.

Valve Train Analysis—Engine Off, Valve Spring Retainer and Valve Spring Retainer Keys

- Check for correct seating of the valve spring retainer key (6518) on the valve stem and in valve spring retainer (6514).
- Check for correct seating on the valve stem.

Valve Train Analysis—Engine Off, Valves and Cylinder Head

- Check for plugged oil drain back holes.
- Check for worn or damaged valve tips.
- Check for missing or damaged guide-mounted valve stem seal.
- Check collapsed valve tappet gap.
- Check installed valve spring height.
- Check for missing or worn valve spring seats.
- Check for plugged oil metering orifice in cylinder head oil reservoir (if equipped).

Static checks (engine off) are to be made on the engine prior to the dynamic procedure.

Valve Train Analysis—Engine Running

- Start the engine and, while idling, check for correct operation of all parts. Check the following:

Valve Train Analysis—Engine Running, Valves and Cylinder Head

- Check for plugged oil drain back holes.
- Check for missing or damaged valve stem seals or guide mounted valve stem seals.
- Check for a plugged oil metering orifice in the cylinder head oil reservoir (4.6L engine only).



DIAGNOSIS AND TESTING (Continued)

If insufficient oiling is suspected, check oil passages for blockage, then accelerate the engine to 1,200 rpm with the transmission in NEUTRAL and the engine at normal operating temperature. Oil should spurt from the rocker arm oil holes such that valve tips and camshaft roller followers are well oiled. With the valve covers (6582) off, some oil splash may overshoot camshaft roller followers.

Valve Train Analysis—Engine Running, Camshaft Lobe Lift—OHC Engines

Check the lift of each camshaft lobe in consecutive order and make a note of the readings.

1. Remove the valve covers.
2. Remove the spark plugs.
3. Install the Dial Indicator Gauge with Holding Fixture so the rounded tip of indicator is on top of the camshaft lobe and on the same plane as the valve tappet.
4. Rotate the crankshaft using a breaker bar and socket attached to the crankshaft pulley retainer bolt. Rotate the crankshaft until the base circle of the camshaft lobe is reached.

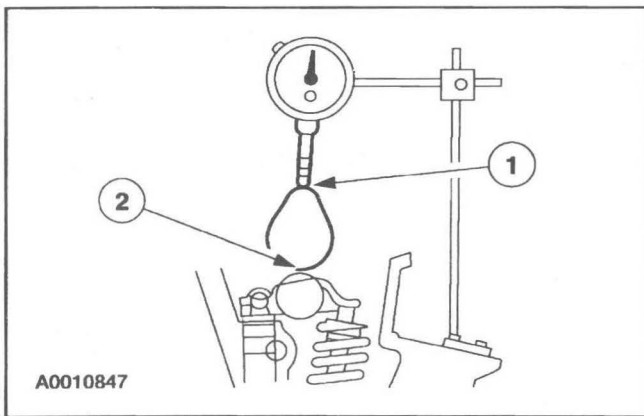

5. Zero the dial indicator. Continue to rotate the crankshaft until the (1) high-lift point of the camshaft lobe is in the fully-raised position (highest indicator reading).
6. To check the accuracy of the original indicator reading, continue to rotate crankshaft until the (2) base circle is reached. The indicator reading should be zero. If zero reading is not obtained, repeat Steps 1 through 6.

NOTE: If the lift on any lobe is below specified service limits, install a new camshaft, and new valve tappets.

BUY IT NOW!

Click Here To Order

with Holding

8. Install the spark plugs.
9. Install the valve covers.

Valve Train Analysis—Engine Running, Camshaft Lobe Lift—Push Rod Engine

Check the lift of each lobe in consecutive order and make a note of the readings.

1. Remove the valve covers.
2. Remove the rocker arm seat bolts, rocker arm seat (6A528) and rocker arms.

Typical Engine With Push Rods

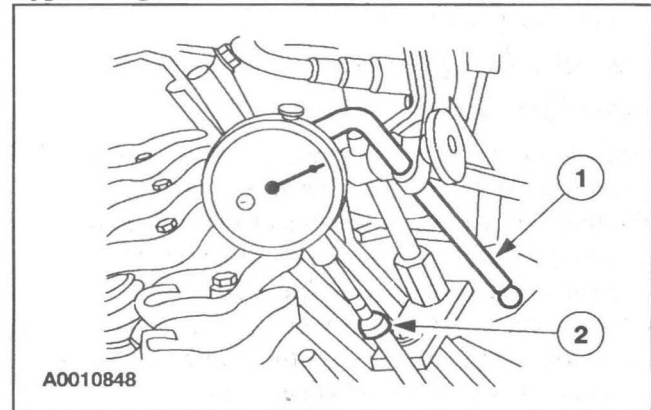

3. Make sure the valve tappet is seated against camshaft (6250). Install (1) Dial Indicator Gauge with Holding Fixture so the ball socket adapter of the indicator is on top of the valve tappet or (2) Dial Indicator Gauge Adapter is on top of push rod and in same plane as valve tappet push rod movement.
4. Remove the spark plugs.
5. Connect an auxiliary starter switch in the starting circuit. Crank the engine with ignition switch in OFF position. Bump crankshaft over until valve tappet is on base circle of camshaft lobe. At this point, valve tappet will be in its lowest position. If checking during engine assembly, turn crankshaft using a socket or ratchet.
6. Zero the dial indicator. Continue to rotate crankshaft slowly until valve tappet is in fully-raised position (highest indicator reading).
7. **NOTE:** If lift on any lobe is below specified service limits, install a new camshaft, and new valve tappets.

Remove the Dial Indicator with Holding Fixture, Dial Indicator Gauge Adapter, and auxiliary starter switch.



DIAGNOSIS AND TESTING (Continued)

8. Install rocker arm seats, rocker arms and rocker arm seat bolts.
9. Install valve covers.
10. Install spark plugs.

Valve Train Analysis—Engine Running, Valve Tappet

Valve tappet noise can be caused by any of the following:

- excessive valve tappet gap (collapsed)
- incorrectly functioning valve tappet
- air in lubrication system
- excessive valve guide wear
- low oil pressure

Excessive collapsed valve tappet gap can be caused by loose rocker arm seat bolts/nuts, incorrect initial adjustment or wear of valve tappet face, or worn roller valve tappets, push rod (6565), rocker arm (6564), rocker arm seat or valve tip. With valve tappet collapsed, check gap between the valve tip and the rocker arm to determine if any other valve train parts are damaged, worn or out of adjustment.

An incorrectly functioning valve tappet can be sticking, caused by contaminants or varnish inside the tappet. The tappet can have a check valve that is not functioning correctly, which can be caused by an obstruction, such as dirt or chips that prevent the check valve from closing, or a broken check valve spring. A tappet with a leakdown time out of specification can cause tappet noise. If no other cause for noisy valve tappets can be found, the leakdown rate should be checked and new valve tappets installed if found to be out of specification.

Assembled valve tappets can be tested with Hydraulic Tappet Leakdown Tester to check the leakdown rate. The leakdown rate specification is the time in seconds for the plunger to move a specified distance while under a 22.7 kg (50 lb) load.

Air bubbles in the lubrication system will prevent the valve tappet from supporting the valve spring load. This can be caused by too high or too low an oil level in the oil pan or by air being drawn into the system through a hole, crack or leaking gasket on the oil pump screen cover and tube.





BUY IT NOW!
Click Here To Order

PayPal American Express Discover MasterCard VISA

GENERAL PROCEDURES

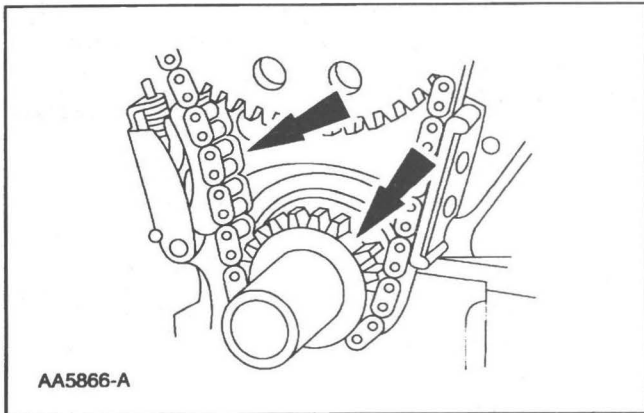
Sprockets



1.  **WARNING:** To avoid the possibility of personal injury or damage to the vehicle, do not operate the engine with the hood open until the fan blade has been examined for possible cracks and separation.

NOTE: Specifications show the expected minimum or maximum condition. Refer to the appropriate section in Group 303 for the procedure.

NOTE: If a component fails to meet the specifications, it is necessary to install a new component or refinish. If the component can be refinished, wear limits are provided as an aid to making a decision. A new component must be installed for any component that fails to meet specifications and cannot be refinished.

Inspect the timing chain/belt and the sprockets.

- Install new components as necessary. Refer to the appropriate section in Group 303 for the procedure.

Rocker Arms — Cleaning

1. Clean all parts thoroughly. Make sure all oil passages are open.
2. Make sure oil passage in the push rod/valve tappet end of the rocker arm (6564) is open.

100% SATISFACTION GUARANTEED

BUY IT NOW!

Click Here To Order 







GENERAL PROCEDURES (Continued)

Rocker Arms — Inspection

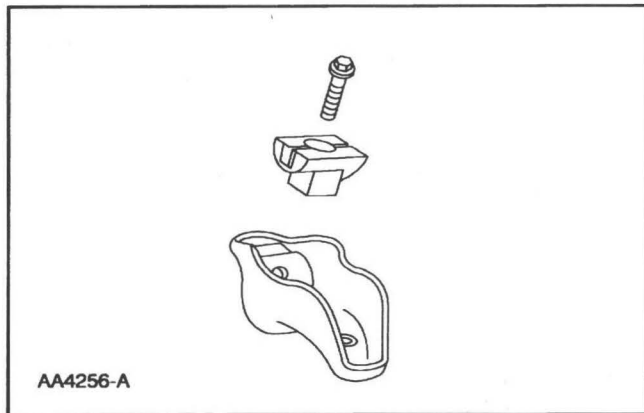

⚠ CAUTION: Do not attempt to true surfaces by grinding. Check the rocker arm pad, side rails and seat for excessive wear, cracks, nicks or burrs. Check the rocker arm seat bolt for stripped or broken threads. Install new components as necessary or possible damage may occur.

1. Inspect the rocker arm push rod bore for nicks, scratches, scores or scuffs. Install new components as necessary. Refer to the appropriate section in Group 303 for the procedure.
2. Inspect the pad at the valve end of the rocker arm for indications of scuffing or abnormal wear. If the pad is grooved, install a new rocker arm. Refer to the appropriate section in Group 303 for the procedure.

Push Rods — Cleaning

1. Clean the push rods (6565) in a suitable solvent. Blow out the oil passage in the push rods with compressed air.

Push Rods — Inspection

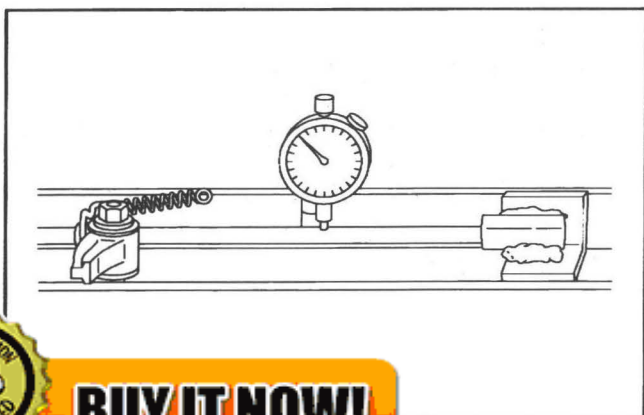

1. **⚠ CAUTION:** Do not attempt to straighten push rods.

Check the ends of the push rods for nicks, grooves, roughness or excessive wear. Install new push rods as necessary. Refer to the appropriate section in Group 303 for the procedure.

- The push rods can be checked for straightness while they are installed in the engine by rotating them with the valve closed.
- They also can be checked using a Dial Indicator with Bracketry.



BUY IT NOW!

Click Here To Order



GENERAL PROCEDURES (Continued)

2. If the push rod is bent beyond specifications, install a new push rod. Refer to the appropriate section in Group 303 for the procedure.

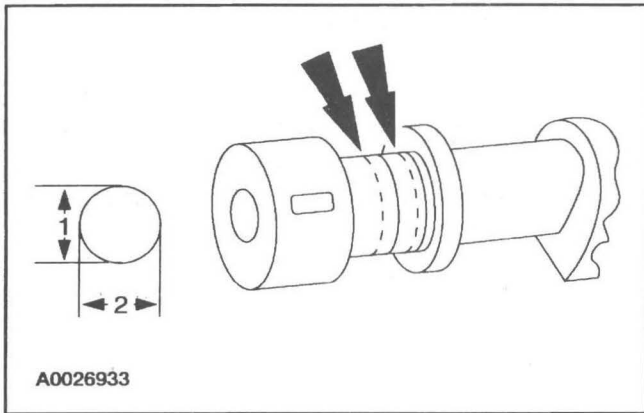
Camshaft Journal — Diameter

1. Measure each camshaft journal diameter in two directions.
 - If out of specification, install new components as necessary. Refer to the appropriate section in Group 303 for the procedure.

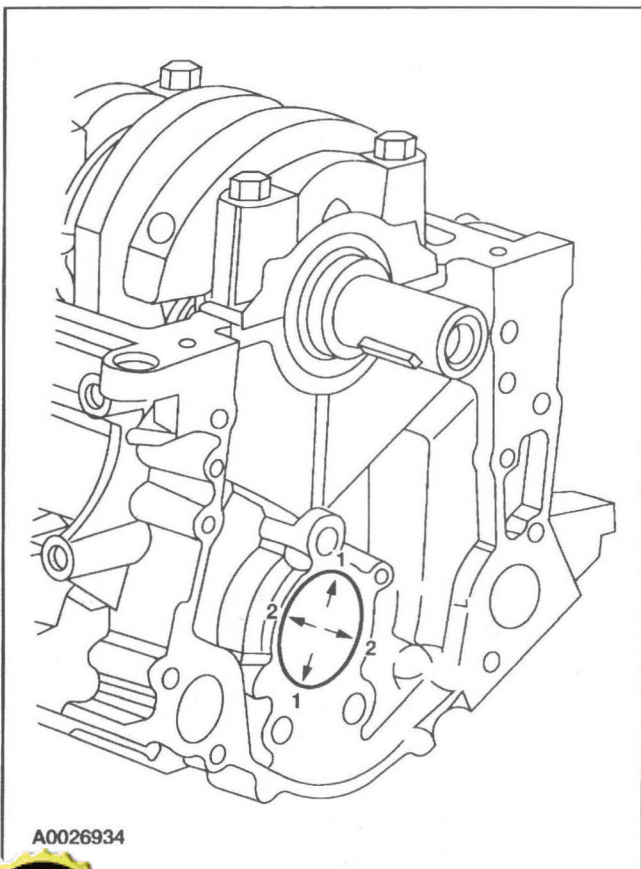
Camshaft Journal — Clearance, Push Rod Engines, Micrometer Method

1. **NOTE:** The camshaft journals must meet specifications before checking camshaft journal clearance.

Measure each camshaft bearing (6261) in two directions.

- Subtract the camshaft journal diameter from the camshaft bearing diameter.

**BUY IT NOW!****Click Here To Order**

PayPal

American Express
CardsDISCOVER
NEWUS

MasterCard

VISA

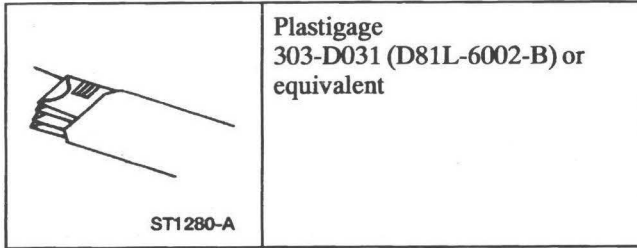
GENERAL PROCEDURES (Continued)**Camshaft Journal — Clearance, Plastigage Method****Special Tool(s)**

NOTE: The camshaft journals must meet specifications before checking camshaft journal clearance.

1. Remove the camshaft bearing cap and lay Plastigage across the surface. Refer to the appropriate section in Group 303 for the procedure.

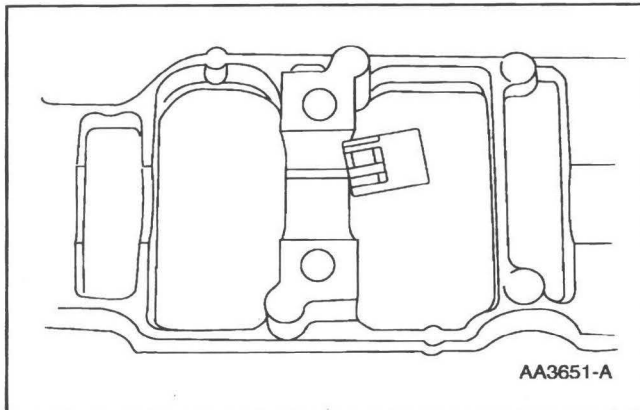

2. **NOTE:** Do not turn the camshaft while carrying out this procedure.

Position the camshaft bearing cap and install the bolts. Refer to the appropriate section in Group 303 for the procedure.

3. Use Plastigage to verify the camshaft journal clearance.
 - If out of specification, install new components as necessary. Refer to the appropriate section in Group 303 for the procedure.

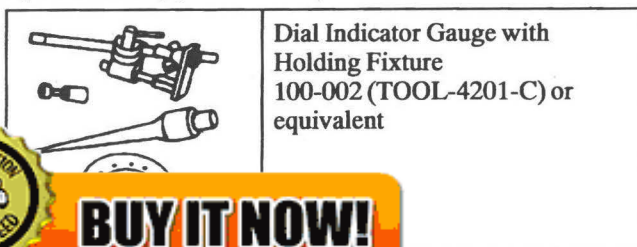
Camshaft End Play — Push Rod Engines**Special Tool(s)**

100% SATISFACTION GUARANTEED

BUY IT NOW!

Click Here To Order



GENERAL PROCEDURES (Continued)

1. Remove the valve tappets. Refer to the appropriate section in Group 303 for the procedure.
2. Use a Dial Indicator Gauge with Holding Fixture to measure camshaft end play.
3. Position the camshaft to the rear of the cylinder block.
4. Zero the indicator.
5. Move the camshaft to the front of the cylinder block. Note and record the camshaft end play.
 - If the camshaft end play exceeds specifications, install a new camshaft thrust plate. Refer to the appropriate section in Group 303 for the procedure.

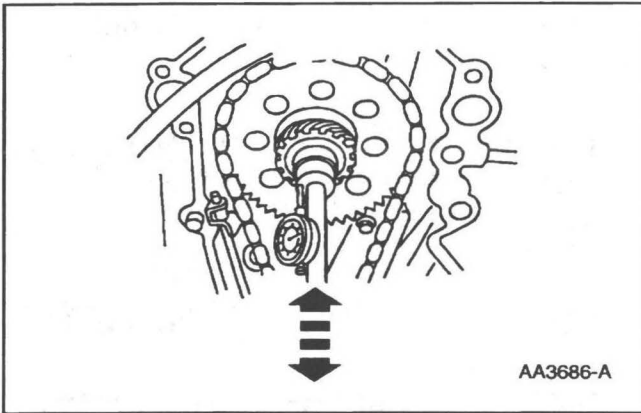
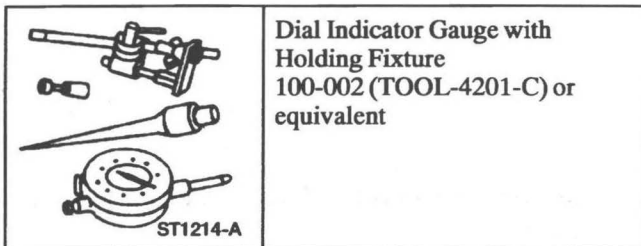
**Camshaft End Play — OHC Engines****Special Tool(s)**

1. Remove the roller followers. Refer to the appropriate section in Group 303 for the procedure.
2. Use a Dial Indicator Gauge with Holding Fixture to measure camshaft end play.
3. Position the camshaft to the rear of the cylinder head.
4. Zero the indicator.

100% SATISFACTION GUARANTEED

BUY IT NOW!

Click Here To Order

GENERAL PROCEDURES (Continued)

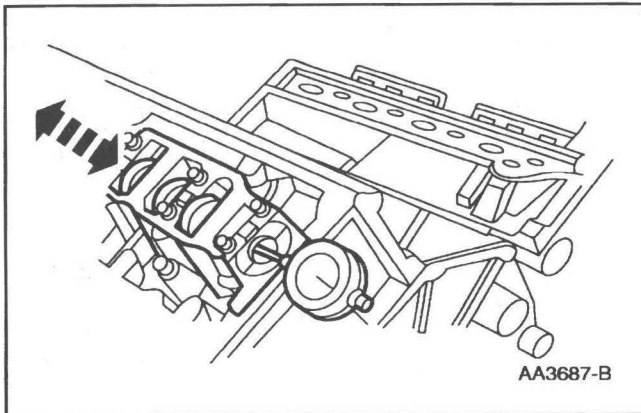

5. Move the camshaft to the front of the cylinder head. Note and record the camshaft end play.
 - If camshaft end play exceeds specifications, install new camshaft and recheck end play. Refer to the appropriate section in Group 303 for the procedure.
 - If camshaft end play exceeds specification after camshaft installation, install a new cylinder head. Refer to the appropriate section in Group 303 for the procedure.

Camshaft — Lobe Surface

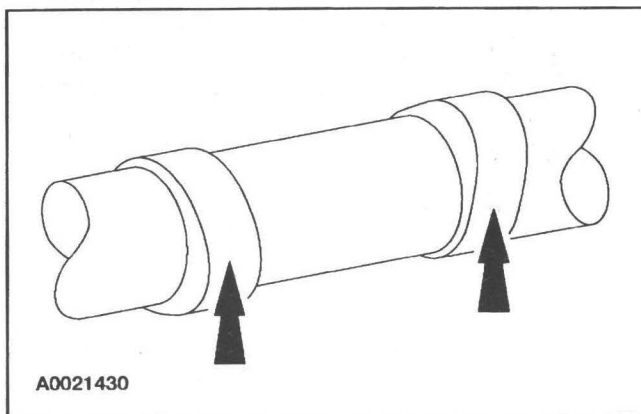

1. Inspect camshaft lobes for pitting or damage in the contact area. Minor pitting is acceptable outside the contact area.
 - If excessive pitting or damage is present, install new components as necessary. Refer to the appropriate section in Group 303 for the procedure.

Camshaft Lobe Lift

Special Tool(s)

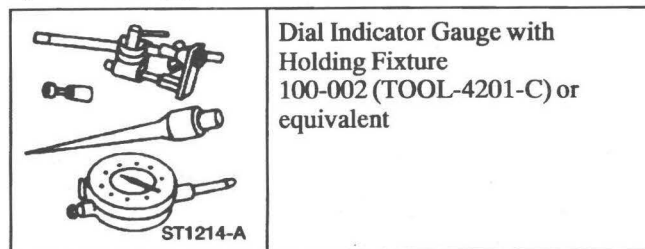

1. Use a Dial Indicator Gauge with Holding Fixture to measure camshaft intake/exhaust lobe lift.
 - Rotate the camshaft and subtract the lowest indicator reading from the highest indicator reading to figure the camshaft lobe lift.
 - Refer to the appropriate section in Group 303 for the procedure.

100% SATISFACTION GUARANTEED

BUY IT NOW!

Click Here To Order

GENERAL PROCEDURES (Continued)

Camshaft Runout

Special Tool(s)

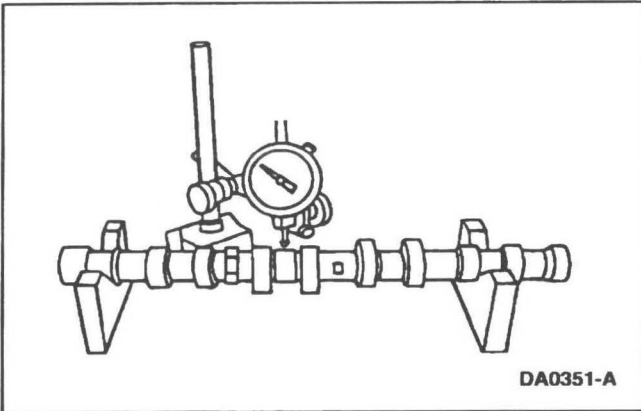
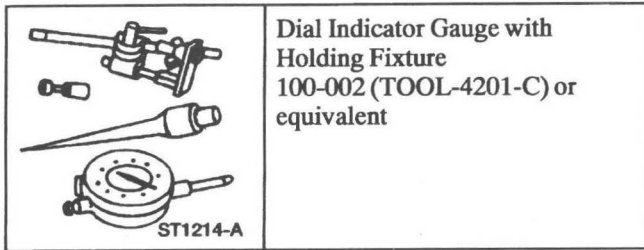

- NOTE:** Camshaft journals must be within specifications before checking runout.
Use a Dial Indicator Gauge with Holding Fixture to measure the camshaft runout.

- Rotate the camshaft and subtract the lowest indicator reading from the highest indicator reading.
- For additional information, refer to the specification chart in the appropriate engine section.
- If out of specification, install new components as necessary. Refer to the appropriate section in Group 303 for the procedure.

Crankshaft Main Bearing Journal — Diameter

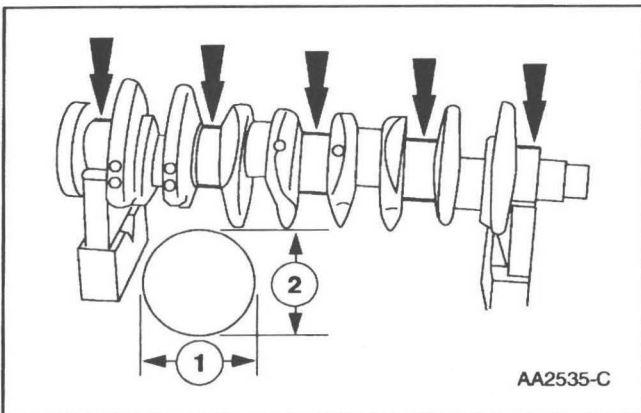

1. Measure each of the crankshaft main bearing journal diameters in at least two directions.
 - Refer to the appropriate section in Group 303 for the procedure.
 - If out of specification, install new components as necessary. Refer to the appropriate section in Group 303 for the procedure.

100% SATISFACTION GUARANTEED

BUY IT NOW!

Click Here To Order

PayPal | American Express | Discover | MasterCard | VISA

GENERAL PROCEDURES (Continued)

Crankshaft Main Bearing Journal — Taper

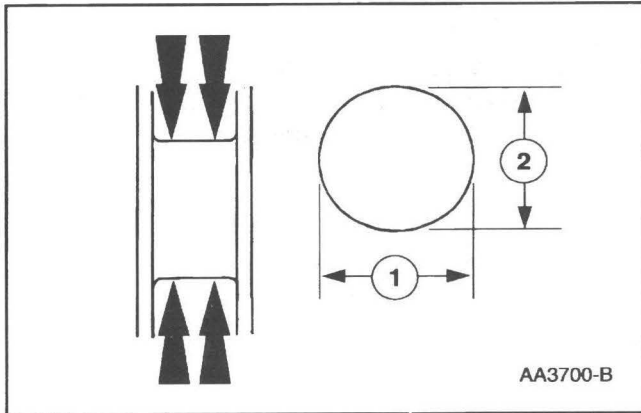

1. Measure each of the crankshaft main bearing journal diameters in at least two directions at each end of the main bearing journal.
 - Refer to the appropriate section in Group 303 for the procedure.
 - If out of specification, install new components as necessary. Refer to the appropriate section in Group 303 for the procedure.

Crankshaft Main Bearing Journal — Clearance

Special Tool(s)

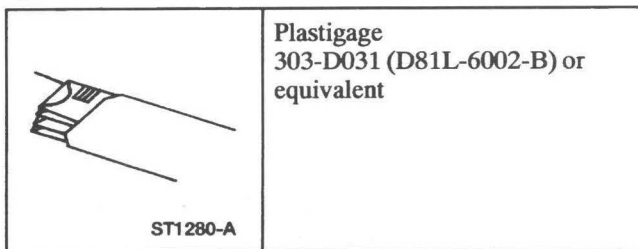

NOTE: Crankshaft main bearing journals must be within specifications before checking journal clearance.

1. Remove the crankshaft main bearing caps and crankshaft main bearing.
2. Lay a piece of Plastigage across the face of each crankshaft main bearing surface.

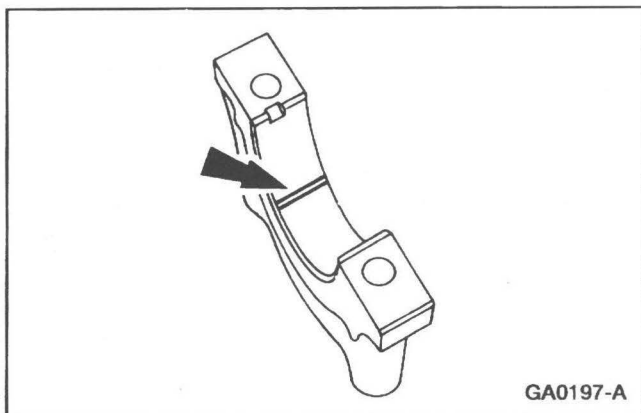

3. **NOTE:** Do not turn the crankshaft while carrying out this procedure.
Install and remove the crankshaft main bearing cap.

100% SATISFACTION GUARANTEED

BUY IT NOW!

Click Here To Order

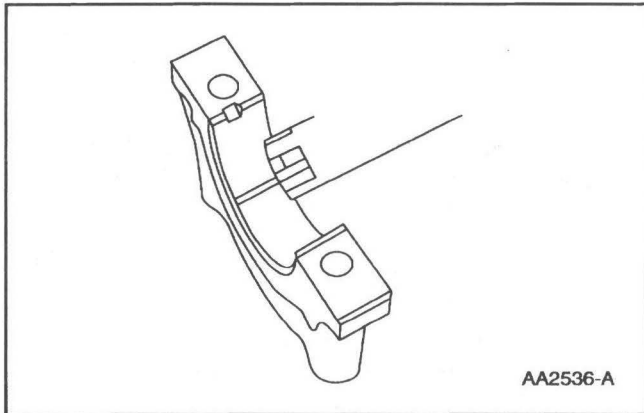
GENERAL PROCEDURES (Continued)

4. Verify the crankshaft journal clearance.
 - Refer to the appropriate section in Group 303 for the procedure.
 - If out of specification, install new components as necessary. Refer to the appropriate section in Group 303 for the procedure.

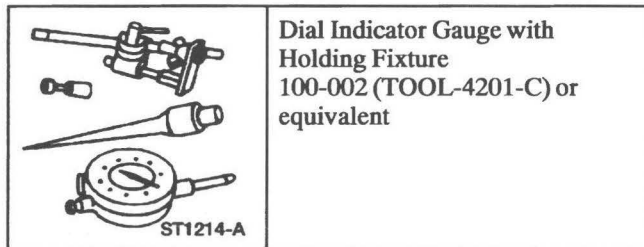
Crankshaft End Play**Special Tool(s)**

Dial Indicator Gauge with Holding Fixture
100-002 (TOOL-4201-C) or equivalent

1. Measure the crankshaft end play. Use a Dial Indicator Gauge with Holding Fixture to measure crankshaft end play.
2. Position the crankshaft to the rear of the cylinder block.
3. Zero the indicator.
4. Move the crankshaft to the front of the cylinder block. Note and record the crankshaft end play.
 - If crankshaft end play exceeds specifications, install a new crankshaft thrust washer (6334) or crankshaft thrust main bearing (6337). Refer to the appropriate section in Group 303 for the procedure.

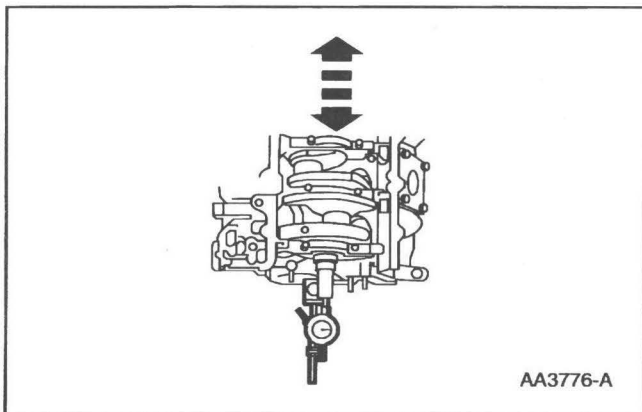

AA3776-A

100% SATISFACTION GUARANTEED

BUY IT NOW!

Click Here To Order

PayPal American Express DISCOVER NOVUS MasterCard VISA

GENERAL PROCEDURES (Continued)

Crankshaft Runout

Special Tool(s)

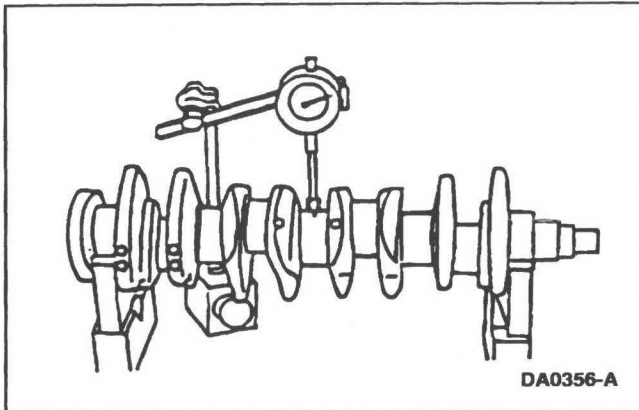
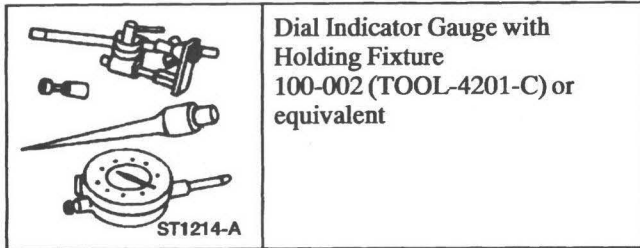

- NOTE:** Crankshaft main bearing journals must be within specifications before checking runout.

Use the Dial Indicator Gauge with Holding Fixture to measure the crankshaft runout.

- Refer to the appropriate section in Group 303 for the procedure.
- Rotate the crankshaft and subtract the lowest dial indicator reading from the highest dial indicator reading to figure the crankshaft runout. If it is out of specification, install new components as necessary. Refer to the appropriate section in Group 303 for the procedure.

Crankshaft — Connecting Rod Journal Taper, Out of Round

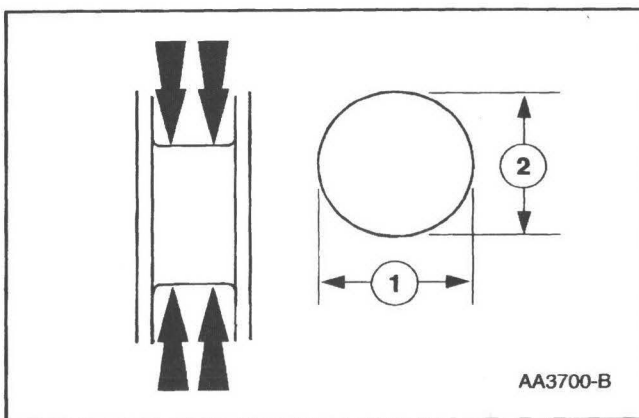

- Measure the crankshaft connecting rod journal diameters in two directions perpendicular to one another at each end of the connecting rod journal. The difference in the measurements from one end to the other is the taper. Verify measurement is within the wear limit.
 - Refer to the appropriate section in Group 303 for the procedure.
 - If out of specification, install new components as necessary. Refer to the appropriate section in Group 303 for the procedure.

100% SATISFACTION GUARANTEED

BUY IT NOW!

Click Here To Order

PayPal | American Express | Discover | MasterCard | VISA

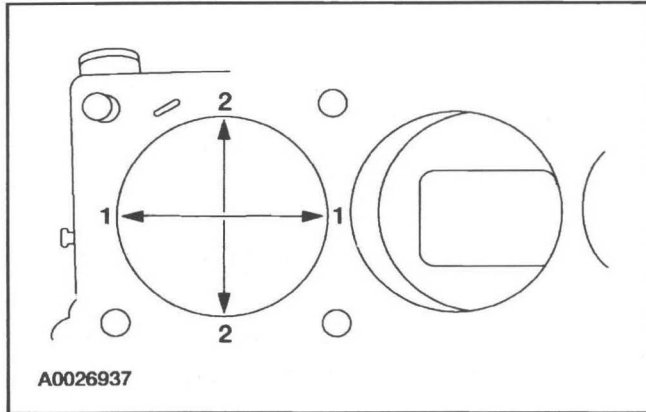
GENERAL PROCEDURES (Continued)**Cylinder Bore — Taper**

1. Measure the cylinder bore at the top, middle, and bottom of piston ring travel in two directions as indicated. Verify the cylinder bore is within the wear limit. The difference indicates the cylinder bore taper. Bore the cylinder to the next oversize.
 - Refer to the appropriate section in Group 303 for the procedure.

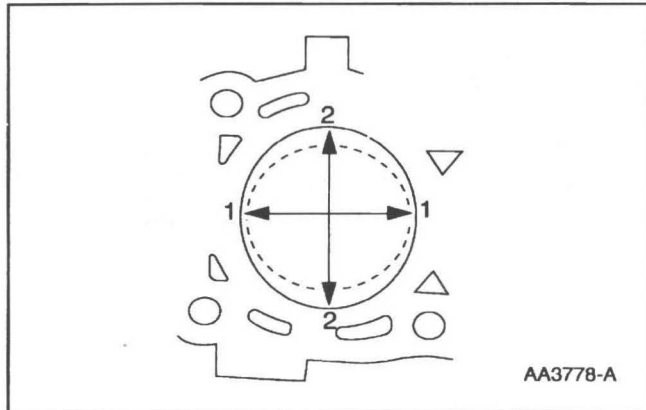
Cylinder Bore — Out-of-Round

1. Measure the cylinder bore in two directions. The difference is the out-of-round. Verify the out-of-round is within the wear limit and bore the cylinder to the next oversize limit.
 - Refer to the appropriate section in Group 303 for the procedure.

Piston Inspection**Special Tool(s)**

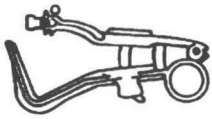
 <p>ST1279-A</p>	<p>Scraper, Piston Ring Groove 303-D033 (D81L-6002-D) or equivalent</p>
---	---

100% SATISFACTION GUARANTEED

BUY IT NOW!

Click Here To Order



GENERAL PROCEDURES (Continued)

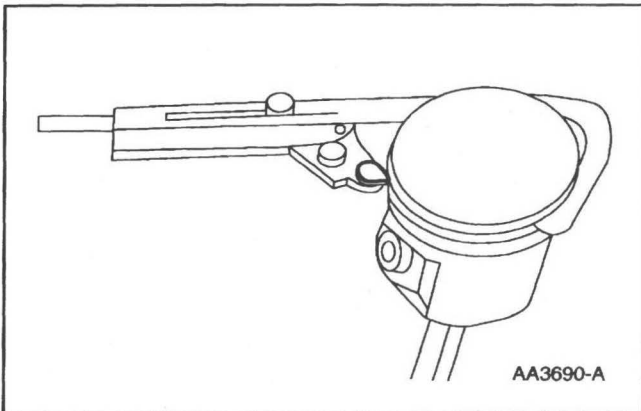
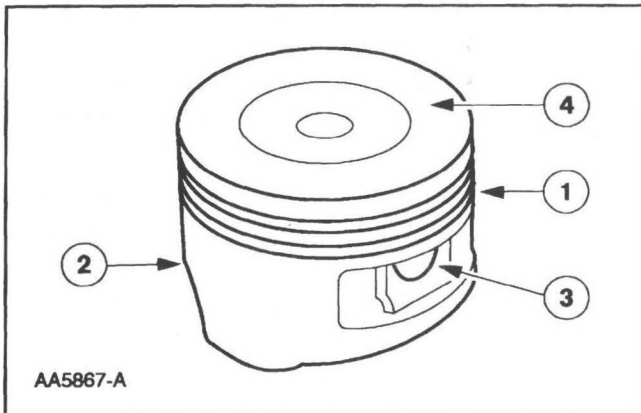

Piston — Pin to Bore Diameter

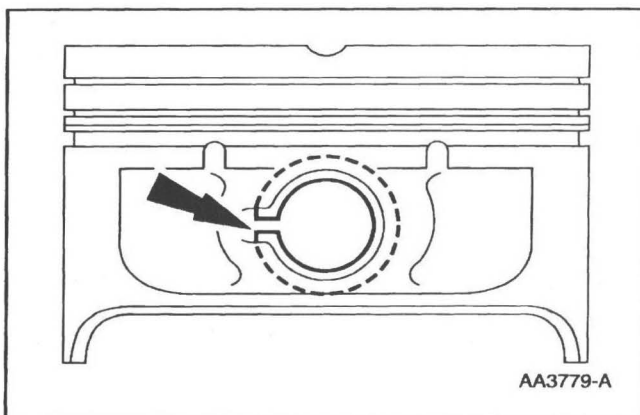

⚠ CAUTION: Do not use a caustic cleaning solution or a wire brush to clean the pistons or damage can occur.

1. Clean and inspect the (1) ring lands, (2) skirts, (3) pin bosses, and the (4) tops of the pistons. If wear marks, scores or glazing is found on the piston skirt, check for a bent or twisted connecting rod.

2. Use the Piston Ring Groove Scraper to clean the piston ring grooves.
 - Make sure the oil ring holes are clean.

1. **⚠ WARNING:** Cover the end of the pin bore with a hand or shop rag when removing the retainer ring, since it has a tendency to spring out. Wear eye protection.

NOTE: Piston and piston pins are a matched set and should not be interchanged.

Measure the piston pin bore diameter in two directions on each side. Verify the diameter is within specification.

- If out of specification, install new components as necessary. Refer to the appropriate section in Group 303 for the procedure.



BUY IT NOW!

Click Here To Order

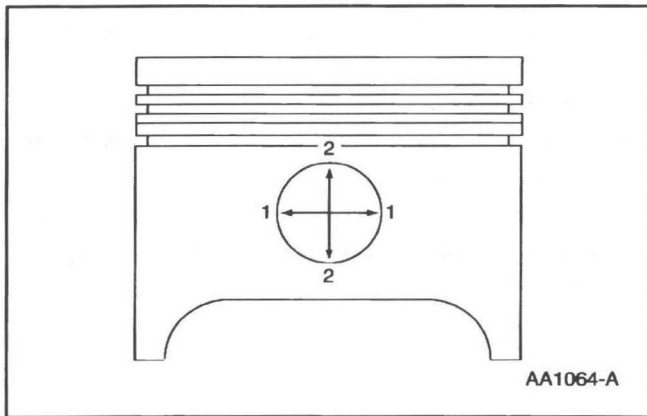
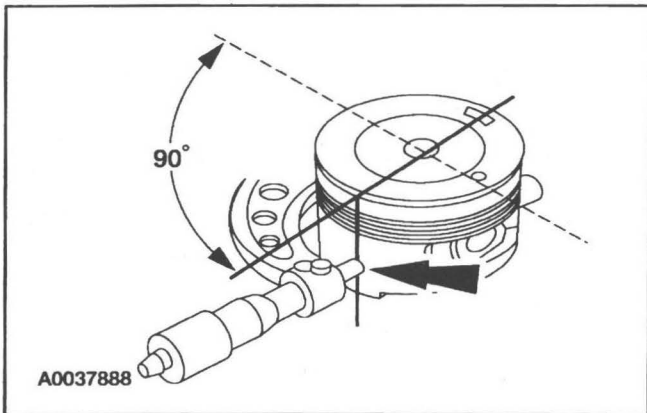

GENERAL PROCEDURES (Continued)**Piston — Diameter****Piston — to Cylinder Bore Clearance**

1. Measure the piston diameter 90 degrees from the piston pin at the point indicated. Refer to the appropriate section in Group 303 for the procedure.
 - If out of specification, install new components as necessary. Refer to the appropriate section in Group 303 for the procedure.

1. Subtract the piston diameter from the cylinder bore diameter to find the piston-to-cylinder bore clearance.

100% SATISFACTION GUARANTEED

BUY IT NOW!

Click Here To Order

PayPal American Express Discover MasterCard VISA

GENERAL PROCEDURES (Continued)

Piston — Selection

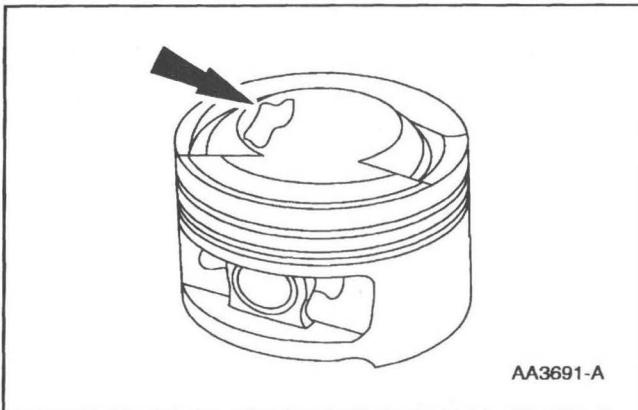
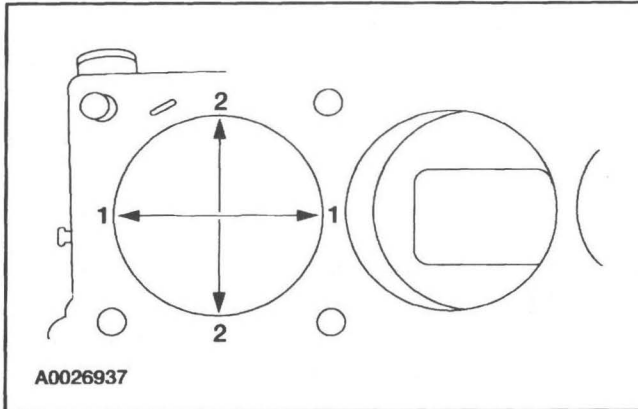

NOTE: The cylinder bore must be within the specifications for taper and out-of-round before fitting a piston.

1. Select a piston size based on the cylinder bore.

2. **NOTE:** For precision fit, new pistons are divided into three categories within each size range based on their relative position within the range. A paint spot on the new pistons indicates the position within the size range.

Choose the piston with the correct paint color.

- Refer to the appropriate section in Group 303 for the procedure.

Piston — Ring End Gap

CAUTION: Use care when fitting piston rings to avoid possible damage to the piston ring or the cylinder bore.

CAUTION: Piston rings should not be transferred from one piston to another.

NOTE: Cylinder bore must be within specification for taper and out-of-round.

100% SATISFACTION GUARANTEED

BUY IT NOW!

Click Here To Order

PayPal | American Express | Discover | MasterCard | VISA

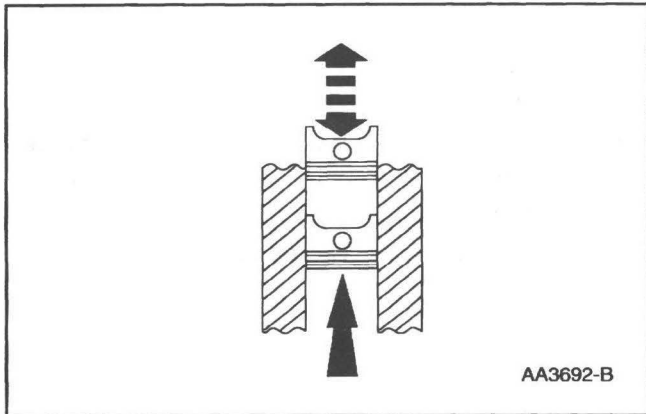
GENERAL PROCEDURES (Continued)

1. Use a piston without rings to push a piston ring in a cylinder to the bottom of ring travel.

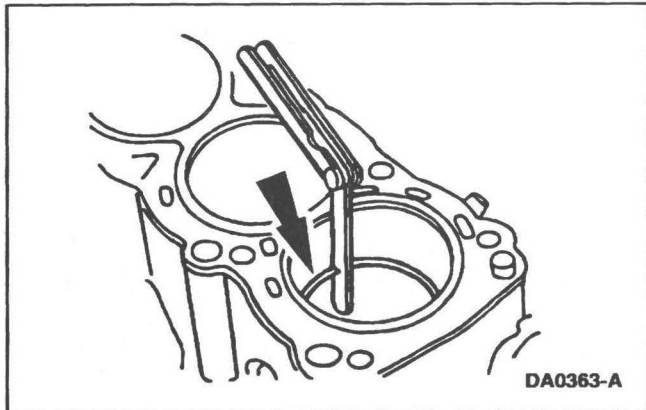

2. Use a feeler gauge to measure the top piston ring end gap and the second piston ring end gap.
 - Refer to the appropriate section in Group 303 for the procedure.

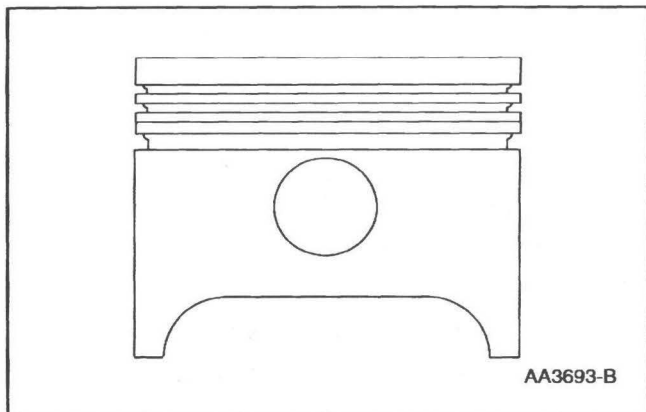
Piston — Ring-to-Groove Clearance

1. Inspect the piston for ring land damage or accelerated wear.



2. Measure the piston ring-to-groove clearance.
 - Refer to the appropriate section in Group 303 for the procedure.
 - If out of specification, install new components as necessary. Refer to the appropriate section in Group 303 for the procedure.

100% SATISFACTION GUARANTEED

BUY IT NOW!

Click Here To Order

GENERAL PROCEDURES (Continued)

Piston — Pin Diameter

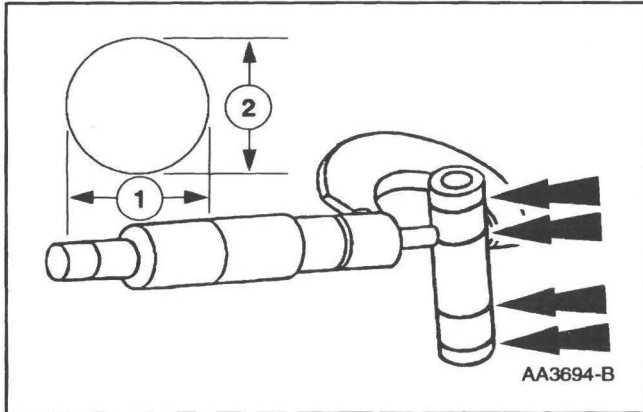

1. Measure the piston pin diameter in two directions at the points shown. Verify the diameter is within specification.
 - Refer to the appropriate section in Group 303 for the procedure.
 - If out of specification, install new components as necessary. Refer to the appropriate section in Group 303 for the procedure.

Connecting Rod — Cleaning

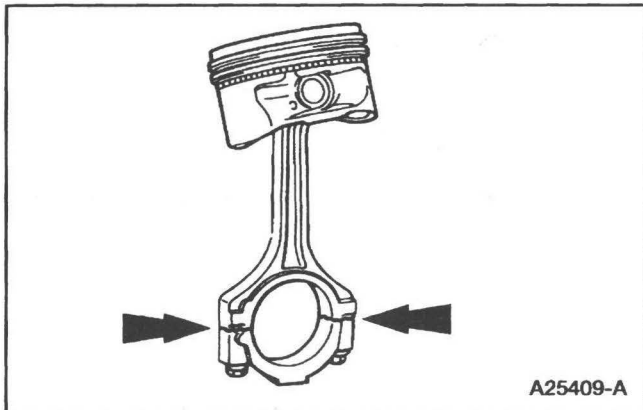

⚠ CAUTION: Do not use a caustic cleaning solution or damage to connecting rods can occur.

1. **NOTE:** The connecting rod large end is a matched set. The connecting rod cap must be installed on the original connecting rod in the original position. Do not reverse the cap. Parts are not interchangeable.

Mark and separate the parts and clean with solvent. Clean the oil passages.

Connecting Rod — Large End Bore

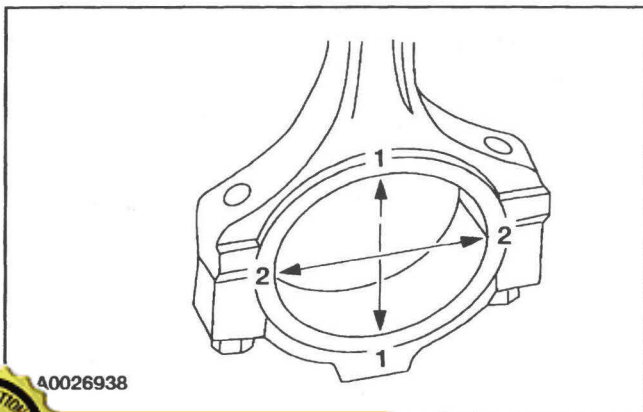

1. Tighten the bolts to specification, then measure the bore in two directions. The difference is the connecting rod bore out-of-round. Verify the out-of-round is within specification.
 - Refer to the appropriate section in Group 303 for the procedure.
 - If out of specification, install new components as necessary. Refer to the appropriate section in Group 303 for the procedure.

100% SATISFACTION GUARANTEED

BUY IT NOW!

Click Here To Order

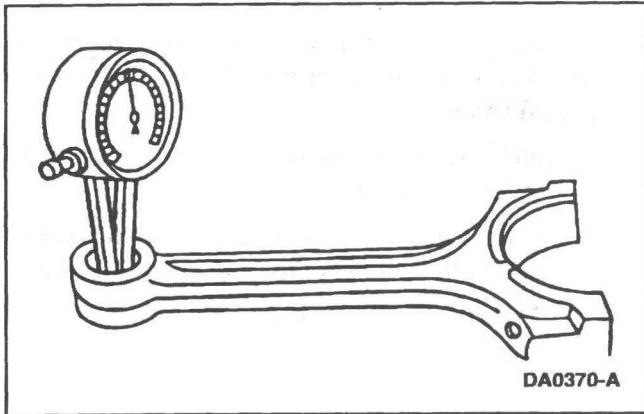
GENERAL PROCEDURES (Continued)**Connecting Rod — Bushing Diameter**

1. Measure the inner diameter of the connecting rod bushing, if equipped. Verify the diameter is within specification.
 - Refer to the appropriate section in Group 303 for the procedure.
 - If out of specification, install new components as necessary. Refer to the appropriate section in Group 303 for the procedure.

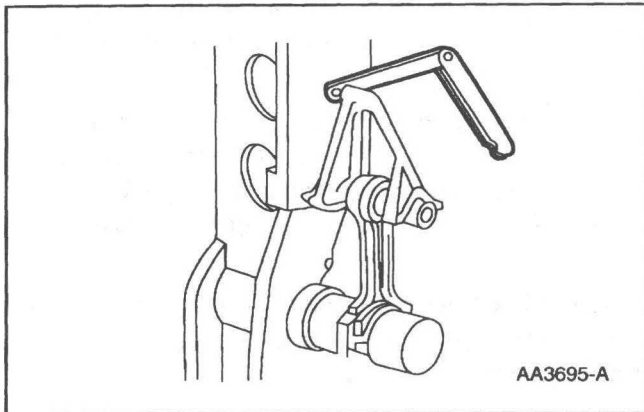
Connecting Rod — Bend

1. Measure the connecting rod bend on a suitable alignment fixture. Follow the instructions of the fixture manufacturer. Verify the bend measurement is within specification.
 - Refer to the appropriate section in Group 303 for the procedure.
 - If out of specification, install new components as necessary. Refer to the appropriate section in Group 303 for the procedure.

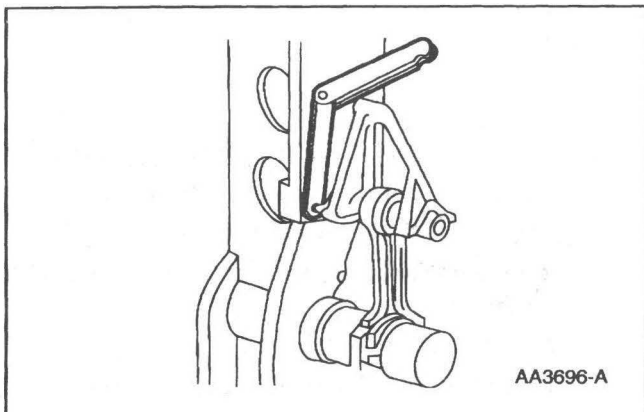
Connecting Rod — Twist

1. Measure the connecting rod twist on a suitable alignment fixture. Follow the instructions of the fixture manufacturer. Verify the measurement is within specification.
 - Refer to the appropriate section in Group 303 for the procedure.
 - If out of specification, install new components as necessary. Refer to the appropriate section in Group 303 for the procedure.

100% SATISFACTION GUARANTEED

BUY IT NOW!

Click Here To Order

GENERAL PROCEDURES (Continued)

Connecting Rod — Piston Pin Side Clearance

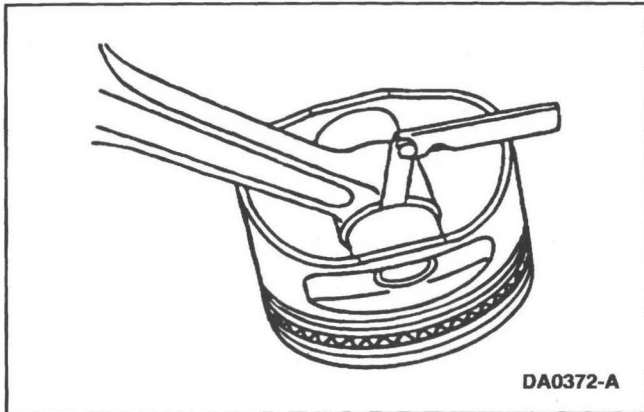

1. Measure the clearance between the connecting rod and the piston. Verify the measurement is within specification.
 - Refer to the appropriate section in Group 303 for the procedure.
 - If out of specification, install new components as necessary. Refer to the appropriate section in Group 303 for the procedure.

Connecting Rod — Bearing Journal Clearance

Special Tool(s)

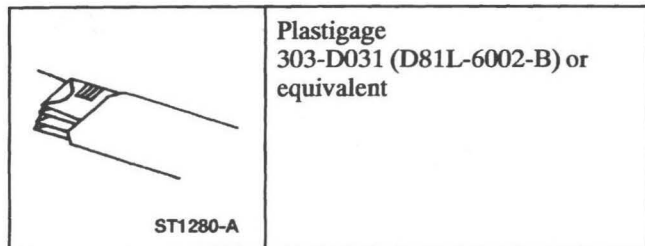

NOTE: The crankshaft connecting rod journals must be within specifications to check the connecting rod bearing journal clearance.

1. Remove the connecting rod bearing cap.
2. Position a piece of Plastigage across the bearing surface.

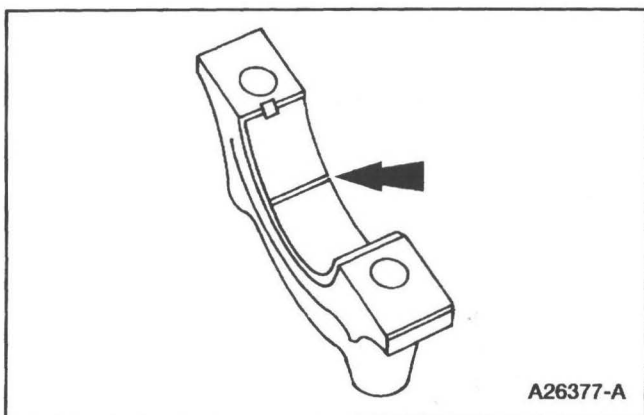

3. **NOTE:** Do not turn the crankshaft during this step.
Install and tighten to specifications, then remove the connecting rod bearing cap.

BUY IT NOW!
[Click Here To Order](#)

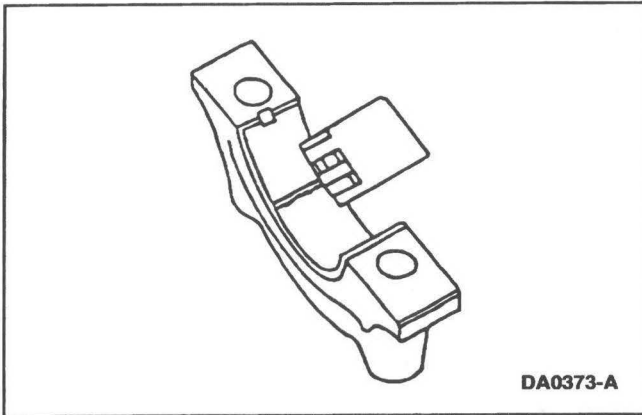
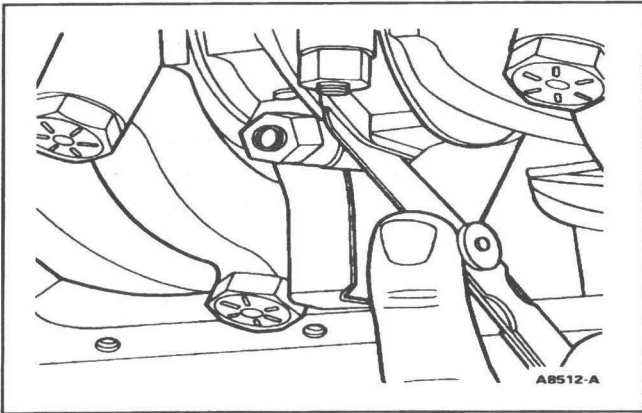
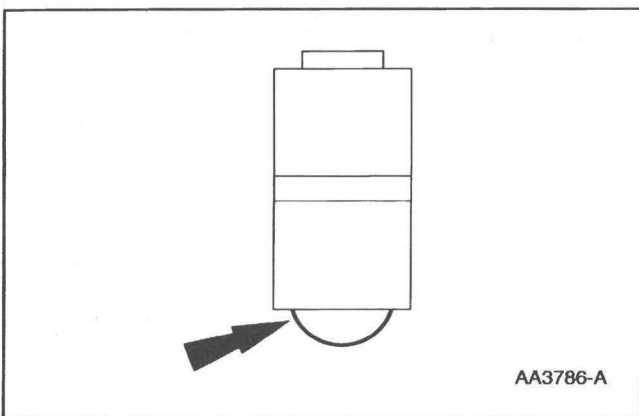

GENERAL PROCEDURES (Continued)**Connecting Rod — Side Clearance****Roller Follower — Inspection**

4. Measure the Plastigage to get the connecting rod bearing journal clearance. The Plastigage should be smooth and flat. A changing width indicates a tapered or damaged connecting rod or connecting rod bearing.
 - Refer to the appropriate section in Group 303 for the procedure.
 - If out of specification, install new components as necessary. Refer to the appropriate section in Group 303 for the procedure.

1. Measure the clearance between the connecting rod and the crankshaft. Verify the measurement is within specification.
 - Refer to the appropriate section in Group 303 for the procedure.
 - If out of specification, install new components as necessary. Refer to the appropriate section in Group 303 for the procedure.

Push rod engines

1. Inspect the roller for flat spots or scoring. If any damage is found, inspect the camshaft lobes and valve tappet for damage.

100% SATISFACTION GUARANTEED

BUY IT NOW!

Click Here To Order

GENERAL PROCEDURES (Continued)

OHC engines

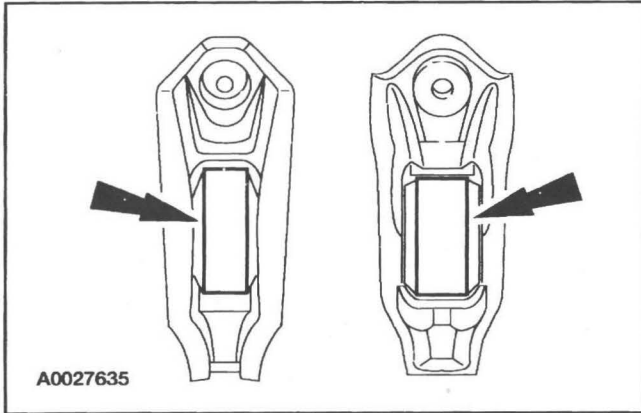

Valve Tappet — Inspection

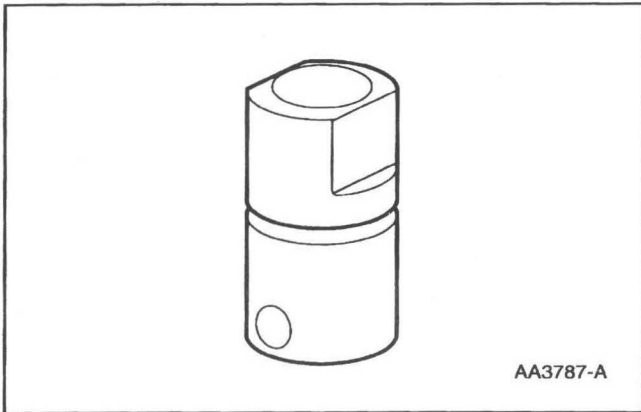

Push rod engines

1. Inspect the hydraulic valve tappet and roller for damage. If any damage is found, inspect the camshaft lobes and valves for damage.

OHC engines

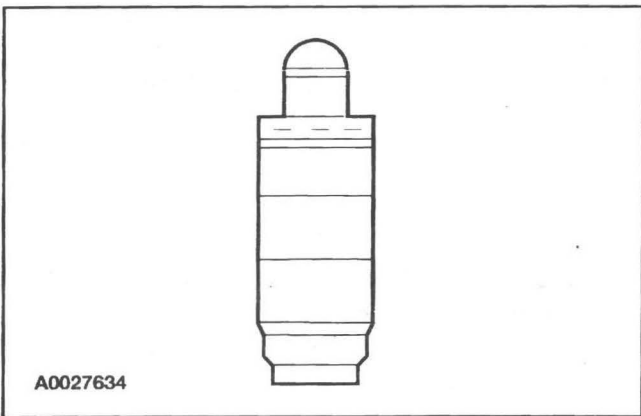

100% SATISFACTION GUARANTEED

BUY IT NOW!

Click Here To Order

Logos for PayPal, American Express, Discover, MasterCard, and VISA are displayed at the bottom of the advertisement.

GENERAL PROCEDURES (Continued)

Valve — Stem Diameter

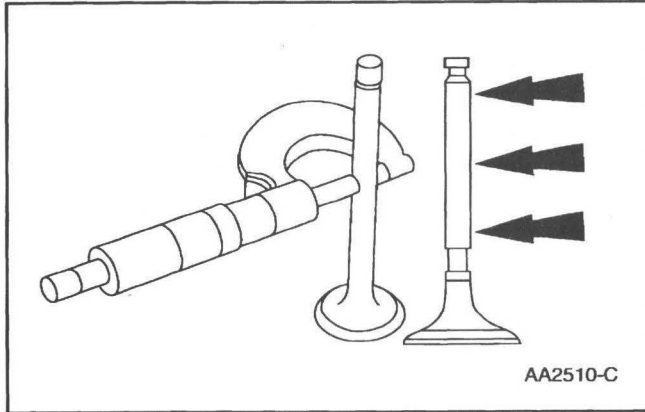

1. Measure the diameter of each intake and exhaust valve stem at the points shown. Verify the diameter is within specification.
 - Refer to the appropriate section in Group 303 for the procedure.
 - If out of specification, install new components as necessary. Refer to the appropriate section in Group 303 for the procedure.

Valve — Stem to Valve Guide Clearance

Special Tool(s)

<p>ST1214-A</p>	<p>Dial Indicator with Bracketry 100-002 (TOOL-4201-C) or equivalent</p>
<p>ST1251-A</p>	<p>Valve Stem Checking Tool 303-004 (TOOL-6505-E) or equivalent</p>

NOTE: Valve stem diameter must be within specifications before checking valve stem to valve guide clearance.



1. **NOTE:** If necessary, use a magnetic base.
Install a Valve Stem Clearance Tool on the valve stem and install a Dial Indicator with Bracketry. Lower the valve until the Valve Stem Clearance Tool contacts the upper surface of the valve guide.

100% SATISFACTION GUARANTEED

BUY IT NOW!

Click Here To Order

GENERAL PROCEDURES (Continued)

Valve — Inspection

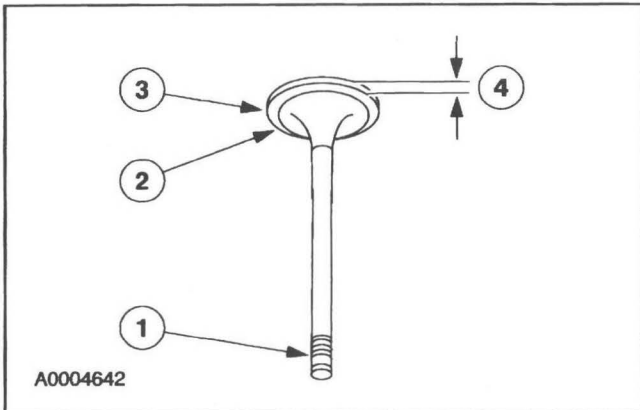

2. Move the Valve Stem Clearance Tool toward the indicator and zero the indicator. Move the Valve Stem Clearance Tool away from the indicator and note the reading. The reading will be **DOUBLE** the valve stem-to-valve guide clearance. Valves with oversize stems will need to be installed if out of specification.

Valve — Guide Inner Diameter

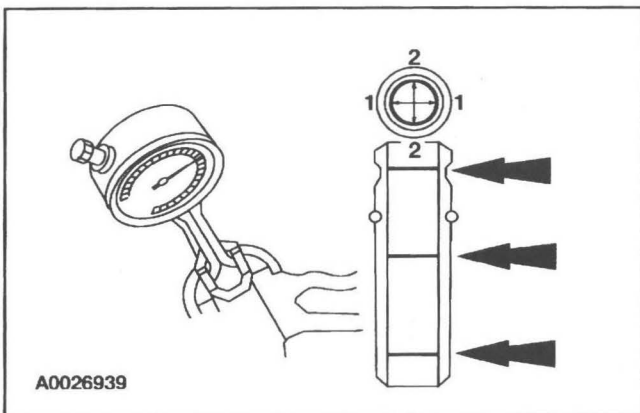

1. Inspect the following valve areas:
 - 1 the end of the stem for grooves or scoring
 - 2 the valve face and the edge for pits, grooves or scores
 - 3 the valve head for signs of burning, erosion, warpage and cracking
 - 4 the valve margin for wear
1. Measure the inner diameter of the valve guides in two directions where indicated.
 - Refer to the appropriate section in Group 303 for the procedure.
2. If the valve guide is not within specifications, ream the valve guide and install a valve with an oversize stem or remove the valve guide and install a new valve guide.

100% SATISFACTION GUARANTEED

BUY IT NOW!

Click Here To Order

PayPal | American Express | Discover | MasterCard | VISA

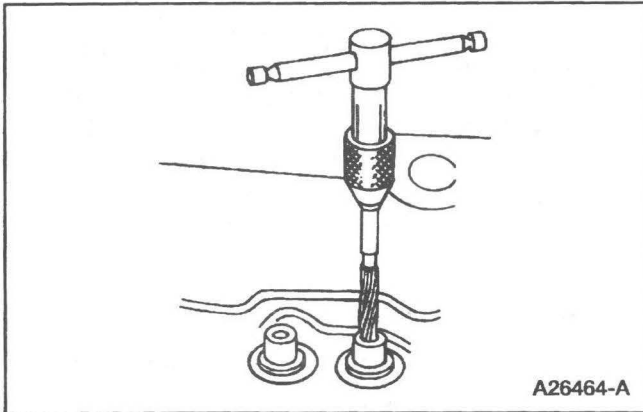
GENERAL PROCEDURES (Continued)**Valve — Guide Reaming**

A26464-A

1. Use a hand-reaming kit to ream the valve guide.

2. Reface the valve seat.
3. Clean the sharp edges left by reaming.

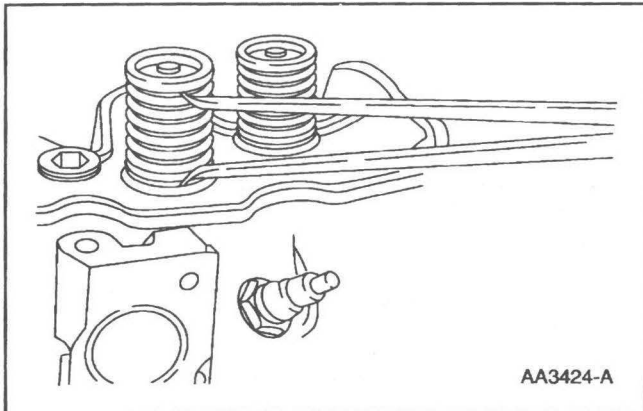
Valve — Spring Installed Length

AA3424-A

1. Measure the installed length of each valve spring.
 - Refer to the appropriate section in Group 303 for the procedure.
 - If out of specification, install new components. Refer to the appropriate section in Group 303 for the procedure.

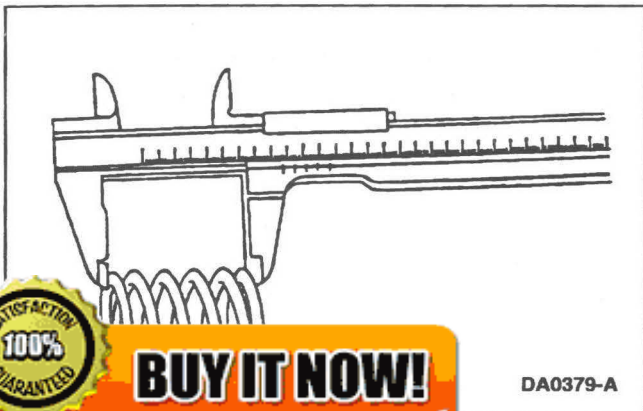
Valve — Spring Free Length

DA0379-A

1. Measure the free length of each valve spring.
 - Refer to the appropriate section in Group 303 for the procedure.
 - If out of specification, install new components as necessary. Refer to the appropriate section in Group 303 for the procedure.

100% SATISFACTION GUARANTEED

BUY IT NOW!

Click Here To Order

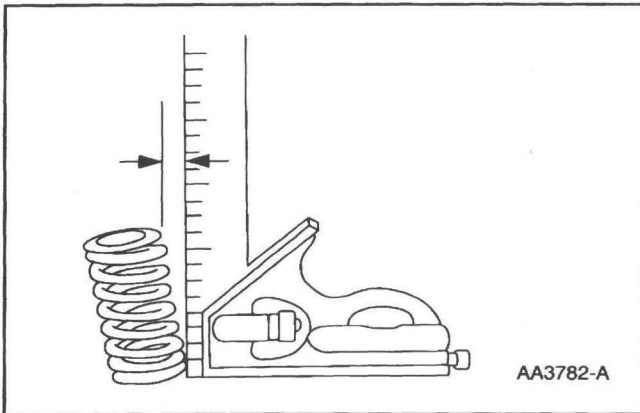

GENERAL PROCEDURES (Continued)**Valve — Spring Squareness**

1. Measure the out-of-square on each valve spring.
 - Turn the valve spring and observe the space between the top of the valve spring and the square. Install a new valve spring if out of square. Refer to the appropriate section in Group 303 for the procedure.

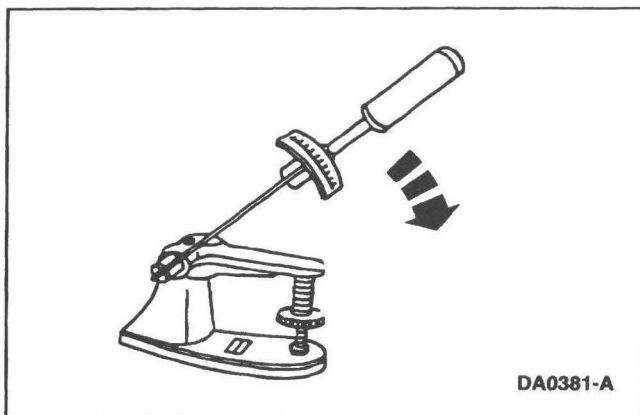
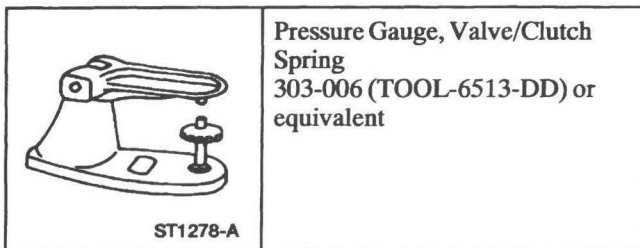
Valve Spring Strength**Special Tool(s)**

1. Use a Valve/Clutch Spring Pressure Gauge to check the valve spring for correct strength at the specified valve spring length.
 - Refer to the appropriate section in Group 303 for the procedure.
 - If out of specification, install new components as necessary. Refer to the appropriate section in Group 303 for the procedure.

100% SATISFACTION GUARANTEED

BUY IT NOW!

Click Here To Order

GENERAL PROCEDURES (Continued)

Valve — Seat Inspection

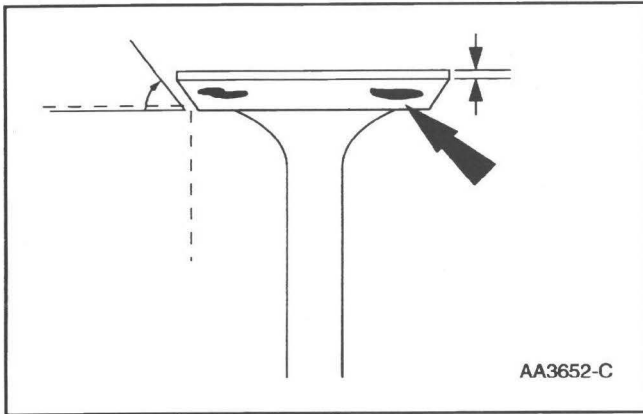

Valve — Seat Width

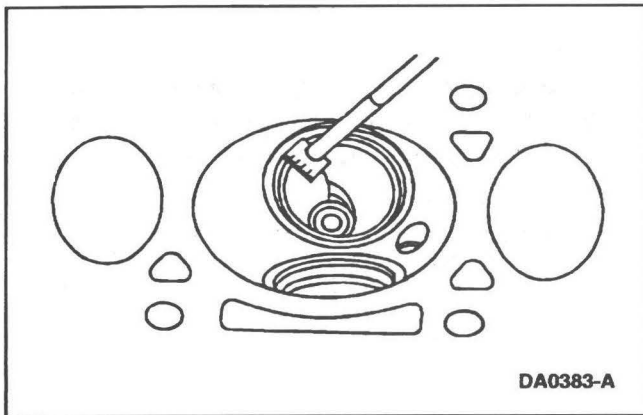

Valve and Seat Refacing Measurements

⚠ CAUTION: After grinding valves or valve seats, check valve clearance.

1. Check the valve head and seat.
 - Check valve angles.
 - Check margin width.
 - Refer to the appropriate section in Group 303 for the procedure.
 - Be sure margin width is within specification.

2. Inspect for abnormalities on the valve face and seat.

1. Measure the valve seat width. If necessary, grind the valve seat to specification.
 - Measure the intake valve seat width.
 - Measure the exhaust valve seat width.
 - Recheck the valve spring installed length after the seats have been ground, and shim the valve springs as necessary to achieve the correct installed spring length.
 - Refer to the appropriate section in Group 303 for the procedure.

100% SATISFACTION GUARANTEED

BUY IT NOW!

Click Here To Order

PayPal | American Express | Discover | MasterCard | VISA

GENERAL PROCEDURES (Continued)

Valve — Seat Runout

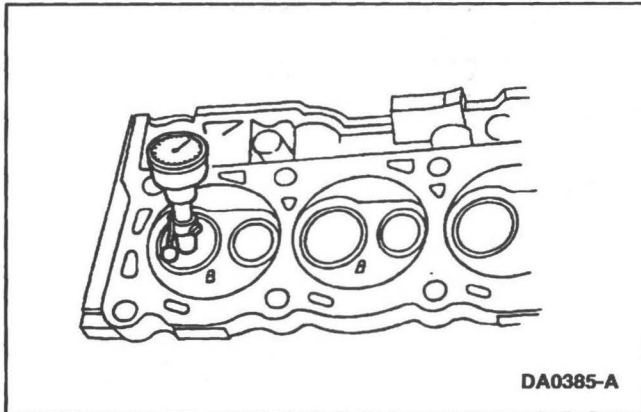

1. Use the Valve Seat Runout Gauge to check valve seat runout.

Cylinder Head — Distortion

Special Tool(s)

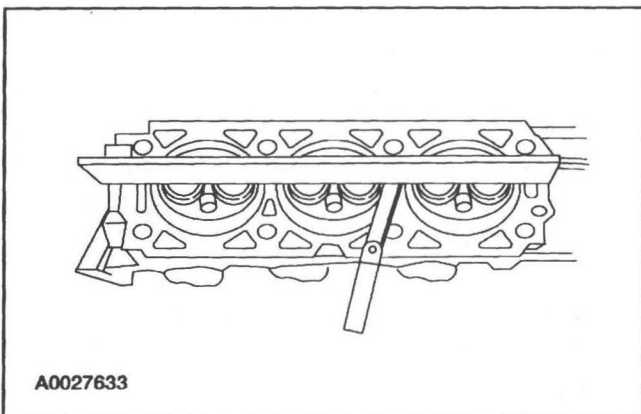
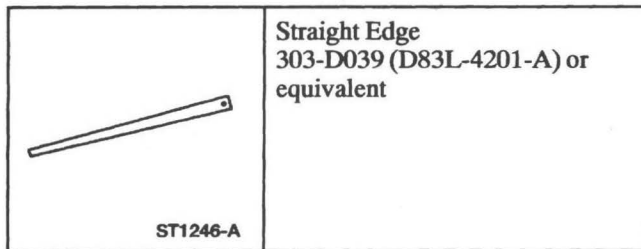

1. Use a straight edge and a feeler gauge to inspect the cylinder head for flatness. If the cylinder head is distorted, install a new cylinder head.

Cylinder Bore — Cleaning

1. **CAUTION:** If these procedures are not followed, rusting of the cylinder bores may occur.

Clean the cylinder bores with soap or detergent and water.

2. Thoroughly rinse with clean water and wipe dry with a clean, lint-free cloth.

100% SATISFACTION GUARANTEED

BUY IT NOW!

Click Here To Order

GENERAL PROCEDURES (Continued)

3. Use a clean, lint-free cloth and lubricate the cylinder bores.
 - Use clean engine oil meeting Ford specification.

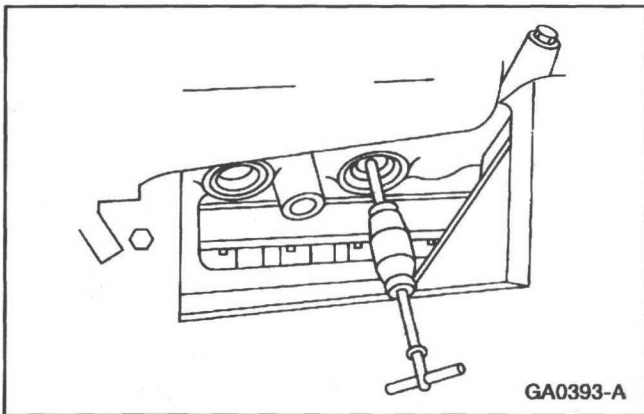
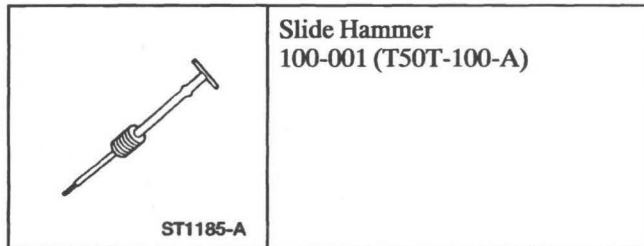
Cylinder Block Core Plug Replacement**Special Tool(s)****Materials**

Item	Specification
Threadlock® 262 E2FZ-19554-A or equivalent	WSK-M2G351-A6

1. Use a slide hammer or tools suitable to remove the cylinder block core plug.
2. Inspect the cylinder block plug bore for any damage that would interfere with the correct sealing of the plug. If the cylinder block plug bore is damaged, bore for the next oversize plug.
3. **NOTE:** Oversize plugs are identified by the OS stamped in the flat located on the cup side of the plug.
Coat the cylinder block core plug and bore lightly with Threadlock® 262 and install the cylinder block core plug.

100% SATISFACTION GUARANTEED

BUY IT NOW!

Click Here To Order



GENERAL PROCEDURES (Continued)

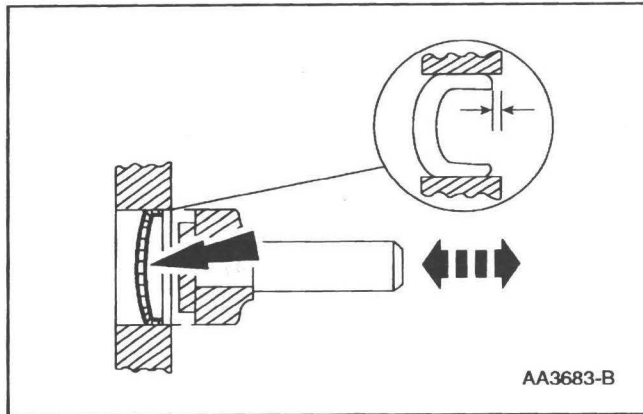

Cup-Type

- CAUTION:** Use care during this procedure so as not to disturb or distort the cup sealing surface.

CAUTION: When installed, the flanged edge must be below the chamfered edge of the bore to effectively seal the bore.

Use a tool suitable to seat the cup-type cylinder block core plug.

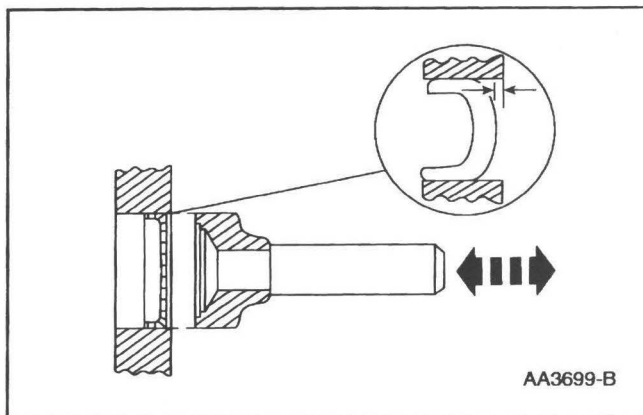

Expansion-Type

- CAUTION:** Do not contact the crown when installing an expansion-type cylinder block core plug. This could expand the plug before seating and result in leakage.

Use tool suitable to seat the expansion-type cylinder block core plug.

Spark Plug Hole Thread Repair

- There is no authorized repair for spark plug hole threads. If the threads are damaged, install a new cylinder head.

Spark Plug — Inspection



- Inspect the spark plug for a bridged gap.
 - Check for deposit build-up closing the gap between the electrodes. Deposits are caused by oil or carbon fouling.
 - Clean the spark plug.

100% SATISFACTION GUARANTEED

BUY IT NOW!

Click Here To Order

PayPal | American Express | DISCOVER | MasterCard | VISA

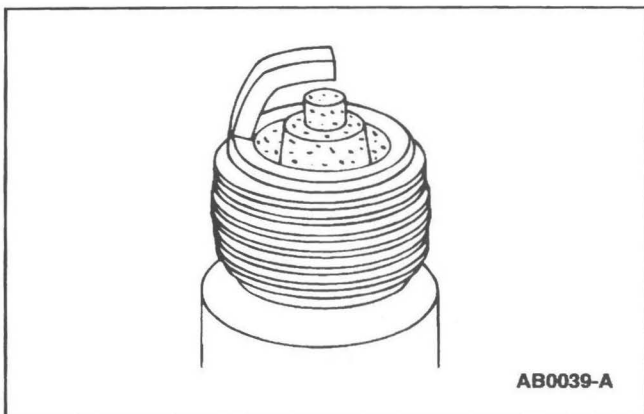
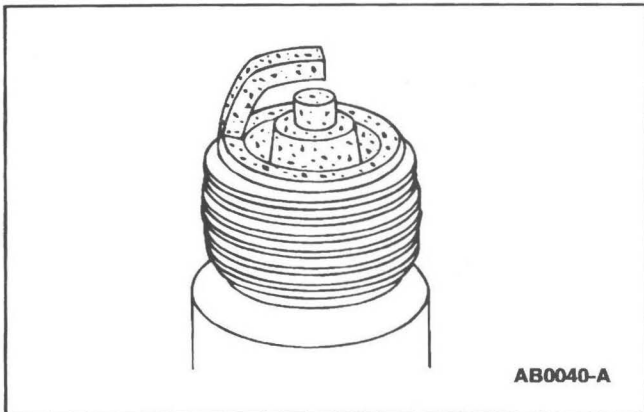
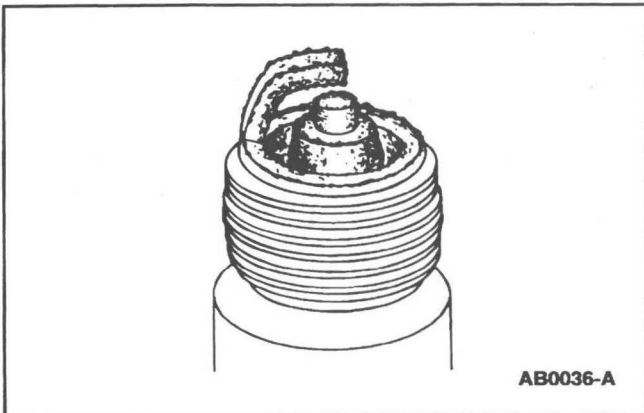
GENERAL PROCEDURES (Continued)

2. Check for oil fouling.
 - Check for wet, black deposits on the insulator shell bore electrodes, caused by excessive oil entering the combustion chamber through worn rings and pistons, excessive valve-to-guide clearance or worn or loose bearings.
 - Correct the oil leak concern.
 - Install a new spark plug.

3. Inspect for carbon fouling. Look for black, dry, fluffy carbon deposits on the insulator tips, exposed shell surfaces and electrodes, caused by a spark plug with an incorrect heat range, dirty air cleaner, too rich a fuel mixture or excessive idling.
 - Clean the spark plug.

4. Inspect for normal burning.
 - Check for light tan or gray deposits on the firing tip.

5. Inspect for pre-ignition, identified by melted electrodes and a possibly damaged insulator. Metallic deposits on the insulator indicate engine damage. This may be caused by incorrect ignition timing, wrong type of fuel or the unauthorized installation of a heli-coil insert in place of the spark plug threads.
 - Install a new spark plug.



BUY IT NOW!

Click Here To Order

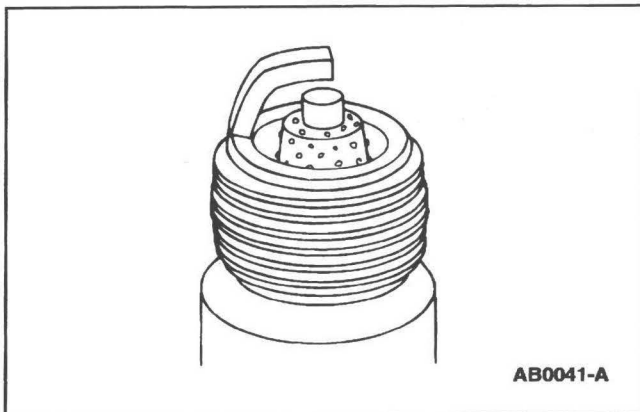
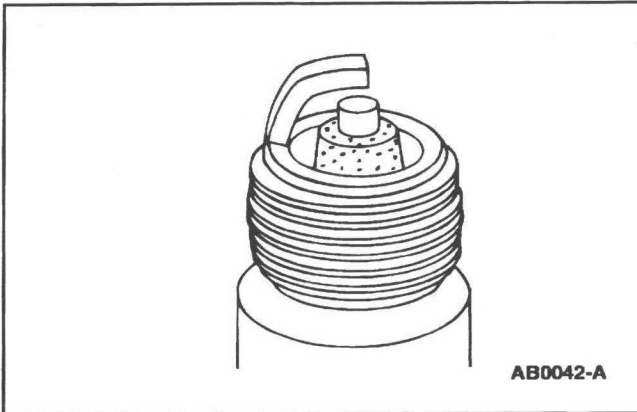

GENERAL PROCEDURES (Continued)

6. Inspect for overheating, identified by a white or light gray spots and with bluish-burnt appearance of electrodes. This is caused by engine overheating, wrong type of fuel, loose spark plugs, spark plugs with an incorrect heat range, low fuel pump pressure or incorrect ignition timing.
 - Install a new spark plug.

7. Inspect for fused deposits, identified by melted or spotty deposits resembling bubbles or blisters. These are caused by sudden acceleration.
 - Clean the spark plug.

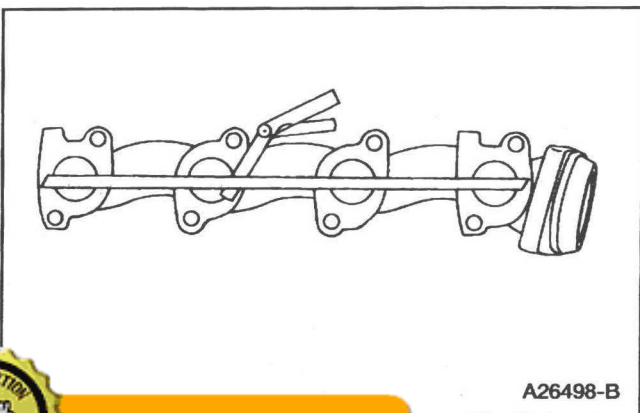
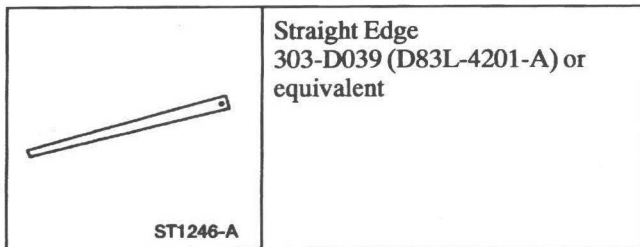
Exhaust Manifold — Inspection**Special Tool(s)**

1. Place a straight edge across the exhaust manifold flanges and check for warping with a feeler gauge.

100% SATISFACTION GUARANTEED

BUY IT NOW!

Click Here To Order

GENERAL PROCEDURES (Continued)

Bearing — Inspection

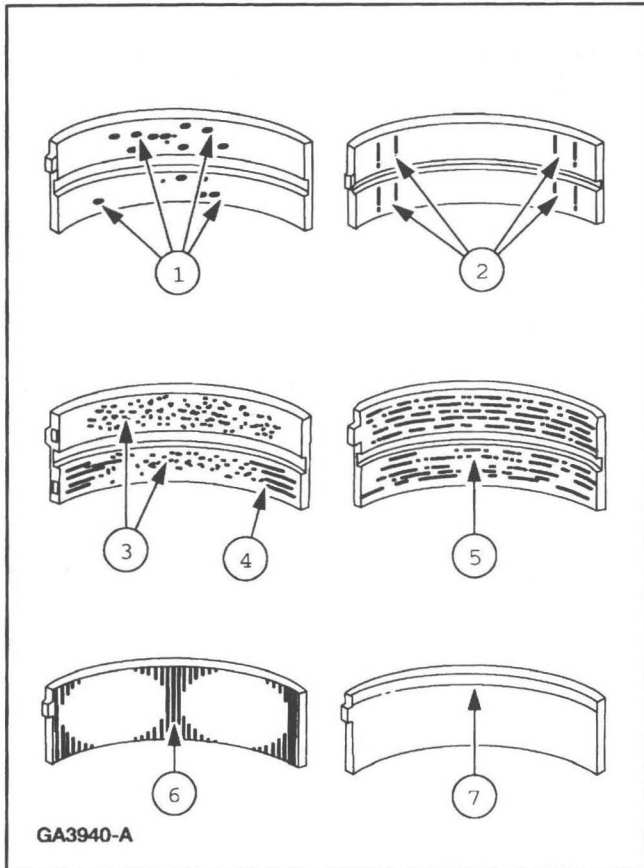

1. Inspect bearings for the following defects. Possible causes are shown:
 - 1 Cratering — fatigue failure.
 - 2 Spot polishing — incorrect seating.
 - 3 Imbedded dirt engine oil.
 - 4 Scratching — dirty engine oil.
 - 5 Base exposed — poor lubrication.
 - 6 Both edges worn — journal damaged.
 - 7 One edge worn — journal tapered or bearing not seated.

100% SATISFACTION GUARANTEED

BUY IT NOW!

Click Here To Order

SECTION 303-01A Engine — 4.2L

CONTENTS	PAGE
SPECIFICATIONS	303-01A-2
DESCRIPTION AND OPERATION	
Engine.....	303-01A-7
DIAGNOSIS AND TESTING	
Engine.....	303-01A-15
IN-VEHICLE REPAIR	
Camshaft.....	303-01A-56
Crankshaft Front Oil Seal	303-01A-41
Crankshaft Pulley	303-01A-38
Crankshaft Rear Oil Seal	303-01A-86
Cylinder Head	303-01A-66
Engine Dynamic Balance Shaft	303-01A-57
Engine Front Cover	303-01A-42
Exhaust Manifold LH	303-01A-62
Exhaust Manifold RH.....	303-01A-64
Flexplate	303-01A-85
Flywheel.....	303-01A-85
Intake Manifold — Spacer Assembly	303-01A-26
Lower Intake Manifold	303-01A-19
Oil Level Indicator and Tube	303-01A-75
Oil Pan — 4x2.....	303-01A-75
Oil Pan — 4x4.....	303-01A-78
Oil Pump	303-01A-82
Oil Pump Screen and Pickup Tube	303-01A-84
Timing Chain — Tensioner.....	303-01A-58
Upper Intake Manifold	303-01A-15
Valve Cover LH.....	303-01A-32
Valve Cover RH	303-01A-35
Valve Spring	303-01A-50
ValveTappet.....	303-01A-53
REMOVAL	
Engine.....	303-01A-87
DISASSEMBLY	
Engine.....	303-01A-94
DISASSEMBLY AND ASSEMBLY OF SUBASSEMBLIES	
Cylinder Head	303-01A-108
Piston.....	303-01A-109
ASSEMBLY	
Engine.....	303-01A-111
INSTALLATION	
.....	303-01A-132



BUY IT NOW!

Click Here To Order



SPECIFICATIONS

General Specifications

Item	Specification
Displacement	4.2L
Number of Cylinders	6
Bore	96.8325 mm (3.81 in)
Stroke	95.0 mm (3.8 in)
Firing Order	1-4-2-5-3-6
Oil Pressure (HOT 2500 rpm)	40-125 psi
Cylinder Head and Valve Train	
Cylinder Head Volume	61.5-64.5
Valve Guide Bore Diameter Intake and Exhaust	7.015-7.044 mm (.276-.277 in)
Valve Seats Width — Intake and Exhaust Angle Runout (T.I.R.)	1.5-2.0 mm (0.06-0.08 in) 44.75 degrees 0.076 mm (0.003 in)
Bore Diameter (Bearing Counterbore Diameter) Intake Exhaust	47.097 mm (1.8542 in) MAX 47.072 mm (1.8532 in) MIN 39.739 mm (1.5645 in) MAX 39.714 mm (1.5635 in) MIN
Gasket Surface Flatness	0.18 mm (0.007 in)
Gasket Surface Finish *	
Valve Stem to Guide Clearance Intake Exhaust	0.020-0.069 mm (0.045-0.090 in) 0.038-0.083 mm (0.0015-0.0033 in)
Valve Head Diameter Intake Exhaust	47.27 mm (1.86 in) 37.1 mm (1.46 in)
Valve Face Runout Limit	0.05 mm (0.002 in)
Valve Face Angle	45.675 degrees
Valve Stem Diameter (STD)	6.955-6.988 mm (0.2735-0.2751 in) 6.962 mm (0.2741 in)

General Specifications

Item	Specification
Enlarge Intake Exhaust	9.075-9.055 mm (0.3573-0.3565 in) 9.063-9.043 mm (0.3568-0.3560 in)
Enlarge Intake Exhaust	9.456-9.436 mm (0.3723-0.3715 in) 9.444-9.424 mm (0.3718-0.3710 in)
Valve Springs	
Compression Pressure (N [Lb] @ Spec Length) Valve Open (Without Damper) Valve Closed (Without Damper) Assembled Height Service Limit	1000 N (224 lbs) @ 29.2 mm (1.16 in) 350 N (79 lbs) @ 40.7 mm (1.62 in) 40.7 mm (1.62 in) 10% Force Loss @ Specified Height
Rocker Arm Ratio	1.73
Valve Tappet, Hydraulic Diameter (Std) Clearance to Bore Service Limit Hydraulic Leakdown Rate Collapsed Tappet Gap Intake Exhaust	22.195-22.212 mm (0.8738-0.8745 in) 0.018-0.068 mm (0.0007-0.0027 in) 0.127 mm (0.005 in) (a) (Nominal) 2.25-4.79 mm (0.089-0.189 in) 2.25-4.79 mm (0.089-0.189 in)
Camshaft Synchronizer Shaft Bearing Bore Diameter Bore Diameter	22.268-22.230 mm (0.8767-0.8752 in)
Camshaft Bore Inside Diameter No. 1 No. 2 No. 3	55.689-55.664 mm (2.192-2.191 in) 55.308-55.283 mm (2.177-2.176 in) 55.308-55.283 mm (2.177-2.176 in)

(Continued)

BUY IT NOW!
[Click Here To Order](#)

SPECIFICATIONS (Continued)**General Specifications**

Item	Specification
No. 4	55.684-55.664 mm (2.192-2.191 in)
Camshaft	
Lobe Lift	
Intake	6.22 mm (0.24 in)
Exhaust	6.57 mm (0.26 in)
Allowable Lobe Lift Loss	0.127 mm (0.005 in)
Theoretical Valve Lift @ Zero Lash	
Intake	11.30 mm (0.45 in)
Exhaust	11.47 mm (0.45 in)
End Play	
Service Limit	0.025-0.150 mm (0.001-0.006 in)
Journal to Bearing Clearance	0.025-0.076 mm (0.001-0.003 in)
Journal Diameter	
All	52.502-52.704 mm (2.067-2.074 in)
Cam Bearing I.D.	
Runout Limit	52.158-52.133 mm (2.0535-2.0525 in) 0.05 mm (0.002 in) Runout of #2 or #3 relative to #1 and #4
Out-of-Round Limit	0.025 mm (0.001 in)
Balance Shaft Bore	
Inside Diameter	55.689-55.664 mm (2.192-2.191 in)
End Plug	0.16-0.075 mm (0.006-0.003 in)
Balance Shaft	
End Play	0.075-0.200 mm (0.003-0.008 in)
Journal Diameter	52.108-52.082 mm (2.0515-2.0505 in)
Runout	0.025 mm (0.001 in)
Camshaft Drive	
Assembled Gear Face Runout	
Crankshaft	0.10 mm (0.004 in)
Camshaft	0.25 mm (0.010 in)
Timing Chain Deflection	12.7 mm (0.5 in)
Cylinder Block	
Cylinder Gasket Surface	0.08 mm (0.003 in) in 2.0 mm (6.00 in)
	@ 0.85.5 @ 2.5

General Specifications

Item	Specification
Cylinder Bore	
Diameter	96.813 mm (3.81 in)
Surface Finish (RMS)	0.45-0.96
Out-of-Round Limit	0.025 mm (0.001 in)
Out-of-Round Service Limit	0.050 mm (0.002 in)
Taper Service Limit	0.050 mm (0.002 in)
Main Bearing Bore	
Diameter	68.905 mm (2.713 in) 68.885 mm (2.712 in)
Crankshaft and Flywheel	
Main Bearing Journal	
Diameter 1, 2, 3	63.983-64.003 mm (2.5190-2.5198 in)
Out-of-Round Limit	0.008 mm (0.0003 in) MAX in 45 degrees, 0.015 mm (0.006 in) TOTAL
Taper Limit	0.008 mm (0.0003 in) per 25 mm (1 in)
Journal Runout Limit	0.05 mm (0.002 in) (2) 0.05 mm (0.002 in) (3)
Surface Finish (RMS)	0.3 micrometers (11.8 micro in)
Thrust Bearing Journal	
Length	29.725-29.775 mm (1.703-1.722 in)
Connecting Rod Journal	
Diameter	58.682-58.702 mm (2.3103-2.3111 in)
Out-of-Round Limit	0.008 mm (0.0003 in) MAX in 45 degrees, 0.015 mm (0.0006 in) TOTAL
Taper Limit	0.008 mm per 25 mm (0.0003 in per in)
Surface Limit (RMS)	0.3 micrometers (11.8 micro in)
Main Bearing Thrust Face	
Surface Finish (RMS)	0.9 micrometers (0.354 micro in) FRONT; 0.6 micrometers (0.236 micro in) REAR
Runout Limit	0.025 mm (0.001 in)
Flywheel Ring Gear Lateral Runout (T.I.R.)	
Automatic Transmission	1.778 mm (0.07 in)
Crankshaft End Play	0.10-0.20 mm (0.004-0.008 in)
Connecting Rod Bearings	
Clearance to Crankshaft	
Desired	0.025-0.035 mm (0.001-0.0014 in)

(Continued)



SPECIFICATIONS (Continued)

General Specifications

Item	Specification
Allowable	0.022-0.069 mm (0.00086-0.0027 in)
Bearing Wall Thickness (Std)	1.453-1.466 mm (0.0572-0.0577 in)
Main Bearings	
Clearance to Crankshaft Desired	0.025-0.035 mm (0.001-0.0014 in)
Allowable	0.013-0.058 mm (0.0005-0.0023 in)
Bearing Wall Thickness	2.435-2.443 mm (0.0959-0.0962 in)
Connecting Rod, Piston and Rings	
Connecting Rod Piston Pin Bore Diameter	22.94-22.98 mm (0.90315-0.90472 in)
Crankshaft Bearing Bore Diameter	61.635-61.655 mm (2.4266-2.4274 in)
Out-of-Round Limit—Piston Pin Bore Taper Limit Piston Bore	0.003 mm (0.00012 in)
Length (Center-to-Center)	154.66-154.74 mm (6.08896-6.09211 in)
Alignment (Bore-To-Bore Max. Diff.) Twist	0.059 per 25 mm (0.002 per in)
Bend	0.04 per 25 mm (0.0016 per in)
Side Clearance (Assembled to Crank) Standard	0.11-0.49 mm (0.0047-0.01929 in)
Service Limit	0.36 mm MAX (0.014 in MAX)
Piston	
Diameter Coded Red	96.795-96.782 mm (3.81082-3.81031 in)
Coded Blue	96.808-96.795 mm (3.81133-3.81082 in)
Coded Yellow	96.821-96.808 mm (3.81184-3.81133 in)
Piston-to-Bore Clearance (Uncoated Clearance)	0.018-0.044 mm (0.00071-0.00173 in)
Piston Selection	Required

General Specifications

Item	Specification
Red	96.826-96.813 mm (3.81204-3.811528 in)
Blue	96.839-96.826 mm (3.81255-3.81204 in)
Yellow	96.852-96.839 mm (3.81306-3.81255 in)
When replacing pistons, measure the cylinder bore as described in Section 303-00. Install the service piston matched to the piston bore diameter above.	
Pin Bore Diameter	23.014-23.018 mm (0.90606-0.90622 in)
Ring Groove Width Compression (Top)	1.54-1.52 mm (0.0606-0.0598 in)
Compression (Bottom)	1.54-1.52 mm (0.0606-0.0598 in)
Oil	3.05-3.03 mm (0.12001-0.11929 in)
Piston Pin Length	63.55-63.05 mm (2.5096-2.4823 in)
Diameter	23.000-23.003 mm (0.90551-0.90563 in)
Pin to Piston Clearance	0.011-0.018 mm (0.00043-0.00071 in)
Pin to Rod Clearance	Press Fit 8 Kilonewtons (1800 lbs)
Piston Rings Ring Width Compression (Top)	1.460-1.490 mm (0.05748-0.05866 in)
Compression (Bottom)	1.460-1.490 mm (0.05748-0.05866 in)
Oil Ring Service Limit	Side Seal—Snug Fit Side Clearance 0.015 mm MAX (0.0006 in MAX)
Ring Gap Compression (Top) (In Gauge)	0.17-0.33 mm (—in)
Compression (Bottom) (In Gauge)	0.3-0.55 (—in)
Oil Ring (Steel Rail) (In Gauge)	0.15-0.165 (0.0059-0.0065 in)
Side Clearance 1st Ring	0.030-0.080 mm (0.00118-0.00315 in)
2nd Ring	0.030-0.080 mm (0.00118-0.00315 in)

(Continued)

BUY IT NOW!

 Click Here To Order
 

SPECIFICATIONS (Continued)**General Specifications**

Item	Specification
(a) 20-200 seconds to leakdown 3.18 mm (0.125 in) with 225 Newtons (50 pounds) load and tappet filled with leak-down fluid.	
(1) Smaller than pin bore measured along center to center axis.	
(2) Runout of journals No. 2 and No. 3 to journals No. 1 and No. 4.	
(3) Runout of adjacent journals to each other.	
Lubrication System	
Oil Pump	
Relief Valve Spring Tension (Force @ Length)	76.2-67.6 N (17.1-15.2 lbs) @ 30.5 mm (1.20 in)
Relief Valve to Bore Clearance	0.073-0.043 mm (0.0029-0.0017 in)
Oil Pump Gear Backlash	0.02-0.03 mm (0.008-0.012 in)
Oil Pump Gear Radial Clearance (Idler and Drive)	0.125-0.050 mm (0.0055-0.002 in)
Oil Pump Gear End Height	0.100-0.010 mm (—in)
Idler Shaft to Idler Gear Clearance	0.044-0.010 mm (0.0017-0.0005 in)
Driver Shaft to Housing Clearance	0.076-0.038 mm (0.0030-0.0015 in)
Oil Capacity	5.5 quarts + 1/2 quart with filter change (6.0 quarts total).

- a Head Gasket Surface - WT=12/2.5. Head Gasket Surface Finish-RZU-13.5 micron. Filter cut off at .08 min TPI @ 3.5 microns below the peak 63 % min. Cut off at .08 mm (0.031496 in), O Ref=2V.

General Specifications

Item	Specification
Super Premium SAE 5W-20 Motor Oil (XO-5W20-QSP)	WSS-M2C153-H
Gasket and Trim Adhesive (F3AZ-19B508-AA)	ESE-M2G52-A
Pipe Sealant with Teflon® (D8AZ-19554-A)	WSK-M2G350-A2
Silicone Gasket and Sealant (F7AZ-19554-EA)	WSE-M4G323-A4
Metal Surface Cleaner (F4AZ-19A536-RA)	WSE-M5B392-A

Torque Specifications

Description	Nm	Lb-Ft	Lb-In
EGR transducer bracket-to-intake manifold bolts	10	—	89
Ignition coil-to-valve cover	6	—	53
Water outlet tube-to-intake manifold stud bolt	10	—	89
EGR tube-to-EGR valve nut	40	30	—
Water outlet tube-to-front water pump bolt	10	—	89
Fuel supply manifold bolts	10	—	89
LH valve cover-to-cylinder head bolts	10	—	89
LH valve cover-to-cylinder head stud bolts	10	—	89
EGR tube-to-exhaust manifold nut	40	30	—
RH valve cover-to-cylinder head bolts	10	—	89
RH valve cover-to-cylinder head stud bolts	10	—	89
Coolant recovery reservoir-to-cylinder head stud bolts	10	—	89
Coolant recovery reservoir-to-bracket bolts	5	—	44
Crankshaft damper bolt	150	111	—
Exhaust manifold flange nuts	40	30	—
Camshaft position sensor bolts	3	—	27
Camshaft synchronizer-to-front-cover bolt	25	18	—
Front cover-to-cylinder block bolts	*	—	—
Radiator fan shroud-to-radiator bolts	9	—	80

(Continued)

100% SATISFACTION GUARANTEED

BUY IT NOW!

Click Here To Order

PayPal American Express Discover MasterCard VISA

SPECIFICATIONS (Continued)**Torque Specifications**

Description	Nm	Lb-Ft	Lb-In
Camshaft thrust plate-to-cylinder block bolts	12	9	—
Camshaft synchronizer drive gear-to-camshaft bolt	45	33	—
Timing chain tensioner-to-cylinder block bolts	12	9	—
Power steering pump bolts	25	18	—
IMRC mounting bracket	10	—	89
Power steering pump reservoir bolts	10	—	89
A/C compressor manifold bolt	21	15	—
Exhaust manifold-to-cylinder head nuts	33	24	—
Power steering pump bracket-to-water pump nuts	20	15	—
Power steering pump bracket-to-generator bracket bolts	20	15	—
Generator bracket-to-cylinder head bolts	40	30	—
Exhaust manifold studs	8	—	71
A/C compressor bracket-to-cylinder head bolts	48	35	—
A/C compressor bracket-to-cylinder head nut	48	35	—
A/C compressor bracket-to-cylinder head stud bolt	25	18	—
Oil level indicator tube-to-cylinder head bolt	10	—	89
Coolant recovery reservoir bracket-to-GOP bolts	9	—	80
Motor mount-to-subframe nuts	115	85	—
Oil pan drain plug	26	19	—
Accessories bracket to	27	20	—
		35	—

Torque Specifications

Description	Nm	Lb-Ft	Lb-In
Front subframe-to-body bolts	90	66	—
Front subframe-to-shock tower bolts	115	85	—
Oil pan-to-cylinder block bolts	*	—	—
Oil pan-to-transmission bell housing	45	33	—
Oil pan baffle nuts	48	35	—
Oil pump cover-to-engine front cover bolts	25	18	—
Oil pump cover-to-engine front cover bolt	10	89	—
Oil pickup tube-to-cylinder block bolts	25	18	—
Oil pickup tube-to-oil pan baffle nut	48	35	—
Flywheel-to-crankshaft bolts	80	59	—
Wire harness bracket-to-motor mount stud-nut	27	20	—
Engine ground strap-to-motor mount nut	27	20	—
Motor mount-to-motor mount bracket bolts	70	52	—
RH motor mount-to-motor mount bracket nut	70	52	—
Hood ground strap-to-hood hinge bolt	12	9	—
Hood hinge nuts	12	9	—
Generator positive cable nut	10	—	89
Power steering pressure tube to pump nut	40	30	—
42-pin connector bolt	10	—	89
Transmission oil cooler tube bracket-to-motor mount bracket nut	27	20	—
Torque converter-to-flywheel nuts	36	27	—
Engine-to-transmission bolts	40	30	—

(Continued)



BUY IT NOW!
Click Here To Order



SPECIFICATIONS (Continued)**Torque Specifications**

Description	Nm	Lb-Ft	Lb-In
Motor mount bracket-to-engine bolts	70	52	—
Motor mount bracket-to-engine nuts	70	52	—
Water pump pulley bolts	25	18	—
Oil bypass filter	•	—	—
Upper intake manifold-to-lower intake manifold bolts	•	—	—
Lower intake manifold-to-cylinder head bolts	•	—	—

(Continued)

Torque Specifications

Description	Nm	Lb-Ft	Lb-In
Rocker arm pivot-to-cylinder head bolts	•	—	—
Intake manifold spacer assembly	•	—	—
Cylinder head bolts	•	—	—
Crankshaft main bearing bolts	•	—	—
Connecting rod cap bolts	•	—	—

a Refer to the procedure.

DESCRIPTION AND OPERATION**Engine**

The 4.2L engine has:

- a V-block with six cylinders and splayed crankpins
- a distributorless ignition system
- a multiport, sequential fuel injection (SFI) system
- a variable length induction system (intake manifold runner control)
- overhead valves
- hydraulic valve tappets (6500) for automatic lash adjustment
- connecting rod parting faces that are unique with an interference fit
- an engine dynamic balance shaft (6A311)



BUY IT NOW!
Click Here To Order







DESCRIPTION AND OPERATION (Continued)

Major Upper Engine Components

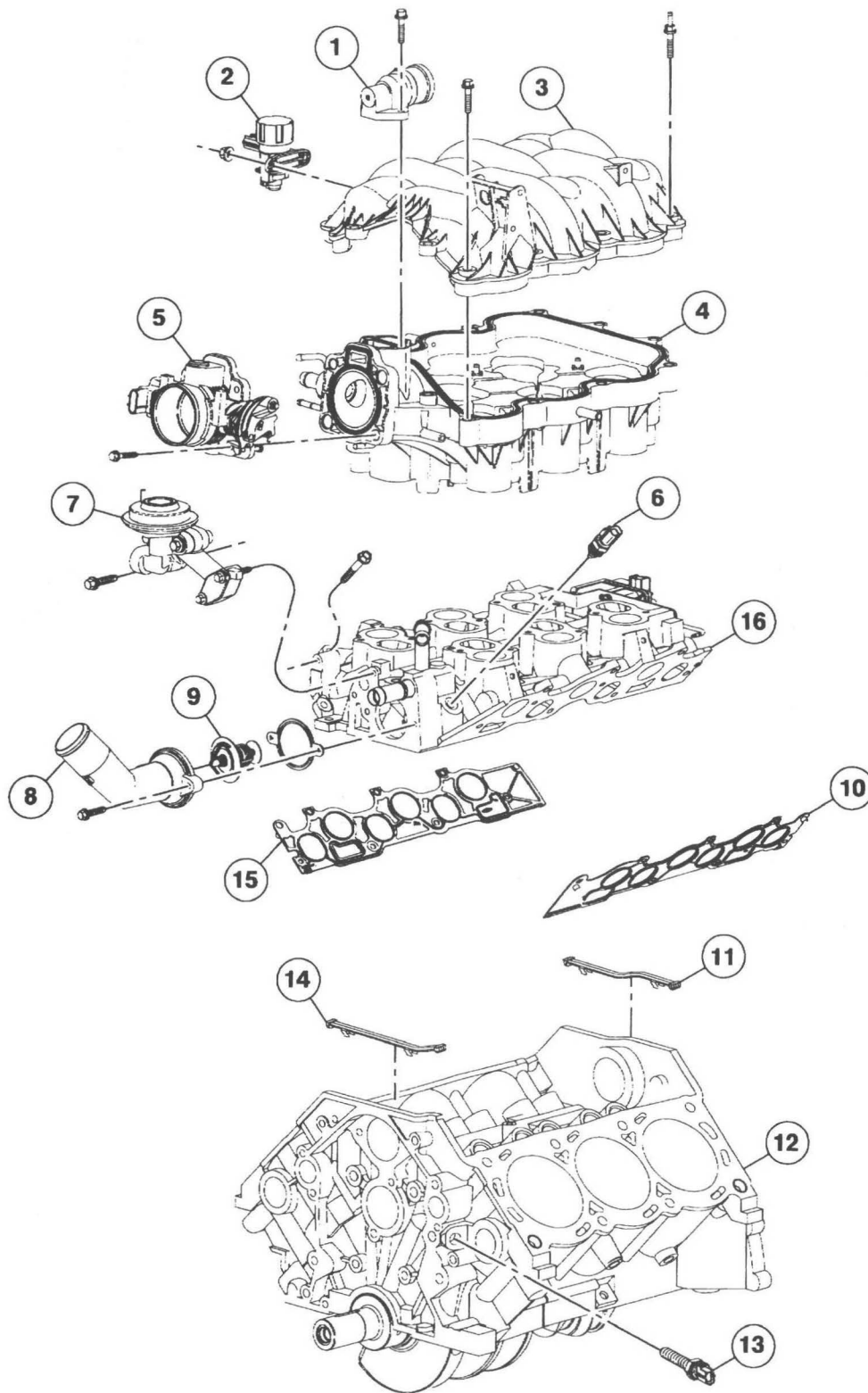

10002746

100% SATISFACTION GUARANTEED

BUY IT NOW!

Click Here To Order

PayPal American Express Discover MasterCard VISA

METRICS

ENGLISH/METRIC CONVERSION

DESCRIPTION	MULTIPLY	BY	FOR METRIC EQUIVALENT
Acceleration	ft/s ²	0.3048	m/s ²
	in/s ²	0.0254	m/s ²
Torque	lb-in	0.11298	N·m
	lb-ft	1.3558	N·m
Power	horsepower	0.746	kW
Pressure or Stress	inches of water	0.2491	kPa
	psi	6.895	kPa
	psi	0.069	bar
Energy or Work	BTU	1055.0	Joules(J)
	lb-ft	1.3558	Joules(J)
	kiloWatt-hour	3,600,000 or 3.6 x 10 ⁶	Joules(J)
Light	foot candle	10.764	lumens/square meter (lm/m ²)
Fuel Performance	miles/gal	0.4251	kilometers/liter (km/L)
	gal/mile	2.3527	liters/kilometer (L/km)
Velocity	mph	1.6093	kilometers/hour (km/h)
Length	inch	25.4	mm
	foot	0.3048	m
	yard	0.9144	m
	mile	1.609	km
Area	square inch (in ²)	645.2	mm ²
		6.45	cm ²
	square ft (ft ²)	0.0929	m ²
	square yard	0.8361	m ²
Volume	cubic inch (in ³)	16387.0	mm ³
		16.387	cm ³
		0.0164	liters (L)
	quart	0.9464	liters (L)
	gallon	3.7854	liters(L)
	cubic yard	0.7646	m ³
Mass	pound	0.4536	kg
	ton	907.18	kg
	ton	0.9078	tonne (t)
Force	kilogram	9.807	N
	ounce	0.2780	N
		4.448	N
	Fahrenheit (°F)	(°F-32) 0.556	degree Celsius (°C)



BUY IT NOW!

Click Here To Order



Alphabetical Index

1

1-2 Accumulator307-01B-170

2

2-3 Accumulator307-01B-171

A

A/C Cycling Switch412-03-35
 Acceleration Control, Description and Operation 310-02-2
 Acceleration Control, Diagnosis and Testing..... 310-02-3
 Symptom Chart..... 310-02-3
 Inspection and Verification..... 310-02-3
 Accelerator Cable — 4.2L..... 310-02-6
 Accelerator Cable — 4.6L..... 310-02-8
 Accelerator Cable — 5.4L.....310-02-10
 Accelerator Cable — Supercharged Engines310-02-12
 Accelerator Pedal — Adjustable 310-02-5
 Accelerator Pedal — Fixed 310-02-4
 Accessory Drive, Description and Operation..... 303-05-2
 Accessory Drive, Diagnosis and Testing 303-05-4
 Inspection and Verification..... 303-05-4
 Symptom Chart..... 303-05-5
 Component Tests 303-05-6
 Accessory Drive — Supercharged Engines 303-05-3
 Accessory Drive Belt Tensioner — Supercharged
 Engines303-05-11
 Adapter 206-04-9
 Air Bag and Safety Belt Pretensioner
 Supplemental Restraint System (SRS),
 Description and Operation501-20B-3
 Driver Air Bag Module501-20B-3
 Clockspring501-20B-3
 Passenger Air Bag Deactivation (PAD) Switch501-20B-4
 Safety Belt Pretensioners501-20B-4
 Passenger Air Bag Module501-20B-4
 Restraints Control Module (RCM)501-20B-4
 Electrical System.....501-20B-5
 Impact Sensors.....501-20B-5
 Air Bag and Safety Belt Pretensioner
 Supplemental Restraint System (SRS),
 Diagnosis and Testing501-20B-5
 Diagnosing Customer Concerns Without Hard
 DTCs501-20B-5
 Restraint System Diagnostic Tool Warning501-20B-5
 Procedures501-20B-6
 Without Hard501-20B-6

**Air Bag and Safety Belt Pretensioner
 Supplemental Restraint System (SRS),
 Diagnosis and Testing (Continued)**

Glossary501-20B-8
 Air Bag Reconnect Checklist501-20B-9
 Air Bag Disposal — Deployed501-20B-116
 Air Bag Disposal — Driver, Undeployed,
 Scrapped Vehicle501-20B-118
 Remote Deployment501-20B-118
 Air Bag Disposal — Passenger, Undeployed,
 Scrapped Vehicle501-20B-120
 Air Bag Disposal — Undeployed Inoperative501-20B-116
 Air Cleaner — Inlet303-12-12
 Air Cleaner — Outlet303-12-11
 Air Cleaner — Supercharged Engines 303-12-14
 Air Cleaner Element303-12-15
 Air Cleaner Element — Supercharged Engines303-12-16
 Air Cleaner Outlet Pipe — 4.2L 303-12-9
 Air Cleaner Outlet Pipe — Resonator, 4.6L and
 5.4L303-12-10
 Air Conditioning412-03-11
 Air Conditioning (A/C) Clutch Air Gap Adjustment 412-00-128
 Air Conditioning (A/C) Compressor — 4.2L412-03-12
 Air Conditioning (A/C) Compressor — 4.6L and
 5.4L412-03-14
 Air Conditioning (A/C) System Check — Retail
 Procedure 412-00-114
 Air Conditioning (A/C) System Flushing 412-00-139
 Air Conditioning (A/C) System Recovery,
 Evacuation and Charging 412-00-136
 Air Conditioning Line (Peanut) Fitting 412-00-121
 Air Conditioning System 412-03-3
 Air Distribution, Description and Operation 412-01-2
 Air Distribution, Diagnosis and Testing 412-01-2
 Ambient Air Temperature Sensor.....412-04-14
 Antenna 415-02-2
 Anti-Lock Brake System (ABS) Module 206-09B-51
 Anti-Lock Control, Description and Operation.....206-09A-2
 Anti-Lock Control, Description and Operation.....206-09B-2
 Anti-Lock Control, Diagnosis and Testing206-09A-2
 Principles of Operation.....206-09A-2
 Inspection and Verification.....206-09A-3
 Symptom Chart.....206-09A-5
 Pinpoint Tests206-09A-9
 Anti-Lock Control, Diagnosis and Testing206-09B-3
 Inspection and Verification — Scan Tool
 Communications Check206-09B-3
 Principles of Operation.....206-09B-3
 Inspection and Verification — Drive Cycle Test206-09B-4
 Symptom Chart.....206-09B-6
 Pinpoint Tests206-09B-9
 Component Test — Intermittent Failures 206-09B-48
 Anti-Theft 419-01-3
 Inspection and Verification..... 419-01-3



BUY IT NOW!

Click Here To Order



Alphabetical Index

Anti-Theft (Continued)

Pinpoint Tests	419-01-6
Symptom Chart	419-01-6
Anti-Theft — PATS	419-01-2
Apply Components	307-01B-20
Arm — Lower, Removal and Installation	204-01A-6
Arm — Lower, Removal and Installation	204-01B-14
Arm — Upper, Removal and Installation	204-01A-10
Arm — Upper, Removal and Installation	204-01B-10
Audio System, Description and Operation	415-01-2
Audio System, Diagnosis and Testing	415-00-2
Inspection and Verification	415-00-2
Symptom Chart	415-00-4
Pinpoint Tests	415-00-6
Audio System, Diagnosis and Testing	415-01-4
Audio Unit	415-01-4
Autolamps	417-01-16
Inspection and Verification	417-01-16
Pinpoint Tests	417-01-17
Symptom Chart	417-01-17
Auxiliary Transmission Fluid Cooler	307-02-8
Axle — Front Drive	205-03-28
Axle Assembly — Front Drive	205-03-18
Axle Housing, Removal and Installation	205-02A-40
Axle Housing, Removal and Installation	205-02B-39
Axle Housing, Removal and Installation	205-02C-44
Axle Housing Casting Porosity (Holes in Casting) Repair	205-00-28
Axle Housing Weld Leaks Repair	205-00-29
Axle Shaft, In-Vehicle Repair	205-02A-5
Axle Shaft, In-Vehicle Repair	205-02B-6
Axle Shaft — Disc Brake	205-02C-6
Axle Shaft — Drum Brake	205-02C-9

B

B-Pillar Trim Panel — SuperCrew	501-05-6
Backing Plate	206-02-16
Ball Joint	204-01B-28
Bar — Stabilizer	204-01B-28
Bar — Stabilizer, Lightning Vehicles	204-02-7
Bar and Link	204-01A-13
Barometric Pressure (BARO) Sensor — Supercharged Engines	303-14-19
Battery, Diagnosis and Testing	414-01-2
Battery, Removal and Installation	414-01-4
Battery And Cables	414-01-2
Battery Cables	414-01-6
Battery Disconnect	414-01-3
Tray	414-01-5
General Procedure	308-00-21
General Procedure	308-01-5

Bearing — Inspection	303-00-48
Bearings — Inspection	308-03-4
Belt — 4.2L	303-05-8
Belt — 4.6L, 5.4L With A/C	303-05-8
Belt — 4.6L, 5.4L Without A/C	303-05-9
Belt — Supercharged Engines	303-05-9
Belt Idler Pulley — 4.2L	303-05-12
Belt Idler Pulley — 4.6L, 5.4L	303-05-12
Belt Idler Pulley — Supercharged Engines	303-05-13
Belt Minder Deactivating/Activating	413-09-29
Preparation	413-09-29
Deactivating/Activating	413-09-29
Belt Tensioner — 4.2L	303-05-10
Belt Tensioner — 4.6L, 5.4L	303-05-10
Bleeding — Components	206-00-19
Bleeding — System	206-00-26
Block Heater	303-03A-29
Blower Motor	412-02-3
Blower Motor Speed Control	412-04-20
Body	501-00-2
Body Closures	501-03-2
Body Sealer Types And Applications	501-00-2
Body System	501-00-3
Inspection and Verification — Body System	501-00-3
Symptom Chart — Body System	501-00-3
Brake Booster, Description and Operation	206-07-2
Hose and Check Valve	206-07-2
Brake Booster, Removal and Installation	206-07-3
Brake Caliper Anchor Plate	206-03-12
Brake Disc Machining	100-04-95
Brake Pedal — Adjustable	206-06-16
Brake Pedal Control Switch	206-06-24
Brake Pedal Motor	206-06-22
Brake Pedal Motor Cable	206-06-23
Brake Shift Interlock Actuator	307-05-17
Brake Shoe Adjustment	206-02-4
Brake Drums Removed	206-02-5
Brake Drums Installed	206-02-6
Brake System, Description and Operation	206-00-3
Brake Fluid	206-00-4
Brake System, Diagnosis and Testing	206-00-4
Symptom Chart	206-00-7
Pinpoint Tests	206-00-9
Component Tests	206-00-17
Bulb — Fog Lamp	417-01-70
Bulb — Headlamp	417-01-68
Bulb — Map Lamp	417-02-43
Bumper — Front	501-19-4
Bumper — Front, Arms	501-19-8
Bumper — Rear	501-19-6
Bumper Arms — Rear, Styleside	501-19-9
Bumper Bracket — Front	501-19-10
Bumper Cover — Lightning	501-19-2
Bumpers	501-19-2



BUY IT NOW!

Click Here To Order



Alphabetical Index

Bushing — Carrier 205-03-22
 Bushing — Control Arm 204-01B-28
 Bushing — Cover 205-03-24
 Bushing — Tube 205-03-26
 Bushings, Bearing and Thrust Washer Locator,
 Description and Operation 307-01A-17
 Bushings, Bearing and Thrust Washer Locator,
 Description and Operation 307-01B-14

C

C-Pillar Trim Panel 501-05-8
 Cable — Lead-In 415-02-2
 Cable Adjustment — Shift Indicator 307-05-14
 Cable and Bracket 307-05-18
 Cable and Bracket Adjustment — 4.2L, 4.6L,
 5.4L, 4R70W and 4R100 Transmission 307-05-15
 Cable and Conduit — Front 206-05-9
 Cable and Conduit — Rear 206-05-11
 Caliper, Disassembly and Assembly 206-03-18
 Caliper, Disassembly and Assembly 206-04-11
 Caliper, Removal and Installation 206-03-9
 Caliper, Removal and Installation 206-04-4
 Camber and Caster Adjustment — 4x2 204-00-15
 Camber and Caster Adjustment — 4x4 204-00-17
 Camshaft, In-Vehicle Repair 303-01A-56
 Camshaft, In-Vehicle Repair 303-01B-143
 Camshaft — Lobe Surface 303-00-23
 Camshaft End Play — OHC Engines 303-00-22
 Camshaft End Play — Push Rod Engines 303-00-21
 Camshaft Journal — Clearance, Plastigage
 Method 303-00-21
 Camshaft Journal — Clearance, Push Rod
 Engines, Micrometer Method 303-00-20
 Camshaft Journal — Diameter 303-00-20
 Camshaft Lobe Lift 303-00-23
 Camshaft Position (CMP) Sensor — 4.2L 303-14-4
 Camshaft Position (CMP) Sensor — 4.6L and
 5.4L 303-14-5
 Camshaft Roller Followers 303-01B-141
 Camshaft Runout 303-00-24
 Canister — Evaporative Emissions 303-13-38
 Canister Vent Solenoid Closing Procedure 303-13-33
 Center Support 307-01A-251
 Central Security Module 419-10-19
 Principles of Operation 419-10-19
 Inspection and Verification 419-10-19
 Pinpoint Tests 419-10-20
 Symptom Chart 419-10-20
 Central Timer Module (CTM)/Generic Electronic
 419-10-16
 419-10-16

**Central Timer Module (CTM)/Generic
 Electronic Module (GEM) (Continued)**
 Principles of Operation 419-10-16
 Inspection and Verification 419-10-17
 Pinpoint Tests 419-10-17
 Symptom Chart 419-10-17
 Charge Air Cooler — Supercharged Engines 303-12-17
 Charging System, Description and Operation 414-00-2
 Charging System, Diagnosis and Testing 414-00-2
 Principles of Operation 414-00-2
 Inspection and Verification 414-00-3
 Symptom Chart 414-00-4
 Pinpoint Tests 414-00-5
 Component Tests 414-00-19
 Child Safety Seat Tether Anchor 501-20A-65
 Climate Control Assembly — EATC 412-04-8
 Climate Control Assembly — Manual A/C 412-04-10
 Climate Control System, Description and
 Operation 412-00-3
 System Airflow Description — Manual Climate
 Control 412-00-8
 System Airflow Description — EATC 412-00-9
 Climate Control System, Diagnosis and Testing 412-00-11
 Inspection and Verification 412-00-16
 Symptom Chart 412-00-19
 Pinpoint Tests 412-00-21
 Clockspring, Removal and Installation 501-20B-179
 Clockspring, Removal and Installation 211-04-37
 Cluster Lens 413-01A-86
 Clutch And Clutch Field Coil 412-03-17
 Clutch Controls, Description and Operation 308-02-2
 Clutch Controls, Diagnosis and Testing 308-02-3
 Clutch Master Cylinder/Reservoir 308-02-5
 Clutch Pedal 308-02-3
 Clutch Pedal Position (CPP) Switch 303-14-36
 Coalescer 310-01B-35
 Coalescer Filter Element 310-01B-38
 Coast Clutch Assembly 307-01A-236
 Column 211-04-38
 Communication Circuit Wiring Repair 418-00-42
 Communications Network, Description and
 Operation 418-00-2
 Communications Network, Diagnosis and Testing 418-00-2
 Principles of Operation 418-00-2
 Inspection and Verification 418-00-3
 Pinpoint Tests 418-00-5
 Compact Disc (CD) Changer — Regular Cab 415-01-6
 Compact Disc (CD) Changer — Super Crew with
 Video System 415-01-8
 Compact Disc (CD) Changer — SuperCab and
 Supercab Without Video 415-01-6
 Compass Calibration 419-11-11
 Compass Display 419-11-13
 Compass Zone Adjustment 419-11-11



BUY IT NOW!

Click Here To Order



Alphabetical Index

Diagnostics, Diagnosis and Testing	307-01B-39	Drive Pinion Seal, In-Vehicle Repair	205-02B-15
Differential Bench Torque Test	205-02C-6	Drive Pinion Seal, In-Vehicle Repair	205-03-12
Differential Case, Disassembly and Assembly	205-03-60	Driveline Angle Inspection	205-00-26
Differential Case, In-Vehicle Repair	205-02A-31	Driveline System, Description and Operation	205-00-3
Differential Case, In-Vehicle Repair	205-02B-30	Driveline System, Diagnosis and Testing	205-00-6
Differential Case, In-Vehicle Repair	205-02C-35	Inspection and Verification.....	205-00-7
Differential Case and Ring Gear — Conventional, Disassembly and Assembly	205-02A-45	Symptom Chart.....	205-00-16
Differential Case and Ring Gear — Conventional, Disassembly and Assembly	205-02B-44	Pinpoint Tests	205-00-17
Differential Case and Ring Gear — Conventional, Disassembly and Assembly	205-02C-47	Component Tests	205-00-20
Differential Case and Ring Gear — Traction-Lok, Disassembly and Assembly	205-02A-50	Driveshaft, Description and Operation.....	205-01-2
Differential Case and Ring Gear — Traction-Lok, Disassembly and Assembly	205-02C-52	Driveshaft, Diagnosis and Testing	205-01-5
Differential Case and Ring Gear — Traction-Lok'	205-02B-49	Driveshaft — Front	205-01-5
Differential Case Runout Check	205-03-7	Driveshaft — Rear, One-Piece	205-01-7
Differential Housing Cover, In-Vehicle Repair	205-02A-19	Driveshaft — Rear, Two-Piece	205-01-9
Differential Housing Cover, In-Vehicle Repair	205-02B-16	Driveshaft Center Bearing.....	205-01-11
Differential Housing Cover, In-Vehicle Repair	205-02C-21	Driveshaft Slip Yoke	205-01-29
Differential Pressure Feedback Exhaust Gas Recirculation (EGR) System — 4.2L and 4.6L	303-08-11	Driveshaft Universal Joint — Double Cardan	205-01-24
Differential Pressure Feedback Exhaust Gas Recirculation (EGR) System — 5.4L.....	303-08-12	Driveshaft Universal Joint — Single Cardan, Flange Yoke	205-01-20
Digital Transmission Range (TR) Sensor, In-Vehicle Repair.....	307-01A-172	Driveshaft Universal Joint — Single Cardan, Slip Yoke	205-01-16
Digital Transmission Range (TR) Sensor, In-Vehicle Repair.....	307-01B-162	Drum	206-02-7
Direct Clutch Assembly and Intermediate Brake Drum	307-01A-253	Drum Brake, Description and Operation	206-02-2
Disassembled Views, Description and Operation	307-01A-10	Drum Brake, Diagnosis and Testing.....	206-02-4
Disassembled Views, Description and Operation	307-01B-8	Dual Converter Y-Pipe	309-00-10
Disc, Removal and Installation.....	206-03-13	Duct — Defrost Nozzles and Side Demister.....	412-01-6
Disc, Removal and Installation.....	206-04-8		
Disc and Pressure Plate	308-01-2		
Disc Check	308-00-19		
Door Ajar Switch.....	501-14-96		
Door Latch Remote Control — Rear, F-150	501-14-91		
Door Lock Actuator	501-14-95		
Door Lock Actuator — Rear, SuperCrew	501-14-95		
Door Lock Cylinder	501-14-90		
Dowels — Flywheel	308-00-22		
Dowels — Flywheel Housing to Block.....	308-00-23		
Draining — Coalescer	310-00C-18		
Draining — Coalescer/Filter	310-00B-4		
Drive Cables and Guide Rails	501-17-22		
Drive Pinion, In-Vehicle Repair	205-02A-21		
Drive Pinion, In-Vehicle Repair	205-02B-18		
Drive Pinion, In-Vehicle Repair	205-02C-23		
Drive Pinion Flange, In-Vehicle Repair.....	205-02A-11		
Drive Pinion Flange, In-Vehicle Repair.....	205-02B-11		
.....	205-02C-16		
.....	205-02A-17		

E

Electronic Compass, Description and Operation.....	419-11-2
Electronic Compass, Diagnosis and Testing.....	419-11-2
Inspection and Verification.....	419-11-2
Pinpoint Tests	419-11-3
Symptom Chart.....	419-11-3
Electronic Engine Controls, Description and Operation	303-14-2
Electronic Engine Controls, Diagnosis and Testing.....	303-14-4
Electronic Engine Controls — Supercharged Engines	303-14-4
Electronic Leak Detection	412-00-130
Electronic Pressure Control (EPC) Solenoid.....	307-01B-154
Engine, Assembly	303-01A-111
Engine, Assembly	303-01B-284
Engine, Description and Operation	303-00-4
Engine, Description and Operation	303-01A-7
Engine, Description and Operation	303-01B-11
Engine, Diagnosis and Testing	303-00-5
Inspection and Verification.....	303-00-5
Symptom Chart.....	303-00-6
Component Tests	303-00-9



BUY IT NOW!

Click Here To Order



Alphabetical Index

Engine, Diagnosis and Testing (Continued)

Compression Test—Compression Gauge Check	303-00-10
Cylinder Leakage Detection	303-00-11
Oil Consumption Test	303-00-11
Intake Manifold Vacuum Test	303-00-13
Excessive Engine Oil Consumption	303-00-14
Valve Train Analysis—Engine Off—Valve Cover Removed	303-00-15
Valve Train Analysis—Engine Running	303-00-15
Engine, Diagnosis and Testing	303-01A-15
Engine, Diagnosis and Testing	303-01B-29
Engine, Disassembly	303-01A-94
Engine, Disassembly	303-01B-244
Engine, Installation	303-01A-132
Engine, Installation	303-01B-330
Engine, Removal	303-01A-87
Engine, Removal	303-01B-234
Engine and Radiator Flushing	303-03A-26
Engine Component View	303-01B-11
Engine Coolant Temperature (ECT) Sensor — 4.2L	303-14-18
Engine Cooling, Description and Operation	303-03A-3
Engine Cooling, Diagnosis and Testing	303-03A-9
Inspection and Verification	303-03A-9
Symptom Chart	303-03A-11
Pinpoint Tests	303-03A-12
Component Tests	303-03A-19
Engine Dynamic Balance Shaft	303-01A-57
Engine Emission Control, Description and Operation	303-08-2
Engine Emission Control, Diagnosis and Testing	303-08-3
Engine Front Cover, In-Vehicle Repair	303-01A-42
Engine Front Cover, In-Vehicle Repair	303-01B-105
Engine Ignition, Description and Operation	303-07A-2
Engine Ignition, Description and Operation	303-07B-2
Engine Ignition, Diagnosis and Testing	303-07A-3
Engine Mount — LH	303-01B-228
Engine Mount — RH	303-01B-231
Evaporative Emission Repair Verification Drive Cycle	303-13-35
Evaporative Emissions, Description and Operation	303-13-2
Evaporative Emissions, Diagnosis and Testing	303-13-4
Principles of Operation	303-13-5
Inspection and Verification	303-13-6
Pinpoint Tests	303-13-7
Symptom Chart	303-13-7
Evaporator Core	412-03-25
Evaporator Core Orifice	412-03-27
Exhaust Gas Recirculation (EGR) Valve — 4.2L	303-08-4
Exhaust Gas Recirculation (EGR) Valve — 4.6L	303-08-5
Exhaust Gas Recirculation (EGR) Valve — 4.4L	303-08-6
Exhaust System, Description and Operation	309-00-14

Exhaust Manifold — Inspection	303-00-47
Exhaust Manifold LH, In-Vehicle Repair	303-01A-62
Exhaust Manifold LH, In-Vehicle Repair	303-01B-150
Exhaust Manifold RH, In-Vehicle Repair	303-01A-64
Exhaust Manifold RH, In-Vehicle Repair	303-01B-149
Exhaust Manifold To Exhaust Gas Recirculation (EGR) Valve Tube — 4.2L	303-08-11
Exhaust Manifold To Exhaust Gas Recirculation (EGR) Valve Tube — 4.6L and 5.4L	303-08-9
Exhaust System, Description and Operation	309-00-2
Exhaust System, Diagnosis and Testing	309-00-9
Symptom Chart	309-00-9
Inspection and Verification	309-00-9
Exhaust System — Lightning	309-00-7
Exhaust System Alignment	309-00-9
Exhaust System Neutralizing	100-04-98
Extension Housing	308-03-7
Extension Housing Gasket — 4x2	307-01A-160
Extension Housing Seal and Bushing	307-01A-157
Extension Housing Seal and Gasket	307-01B-149
Exterior Front Door Handle	501-14-81
Exterior Lighting	417-01-2
Exterior Mirror	501-09-16
Exterior Rear Door Handle — F-150	501-14-83
Exterior Rear Door Handle — SuperCrew	501-14-85
Exterior Trim	501-08-2
External Controls, Description and Operation	307-05-2
External Controls, Diagnosis and Testing	307-05-3
Inspection and Verification	307-05-3
Symptom Chart	307-05-3
Pinpoint Tests	307-05-4

F

Fender — Front	501-02-7
Fill	211-00-16
Filler Pipe	310-01A-17
Filler Valve — Compressed Natural Gas (CNG)	310-01C-15
Filler Valve — Fuel	310-01B-33
Filler Valve — Liquefied Petroleum Gas (LPG)	310-01C-12
Filter	310-01A-19
Filter — Coalescent	310-01C-17
Filter — Fuel Filler Valve	310-01B-34
Fittings — R-Clip	310-00A-11
Fittings — Vapor Tube	310-00A-13
Flexplate	303-01A-85
Flexplate — Automatic Transmission	303-01B-216
Floor Console — Rear	501-12-32
Floor Duct	412-01-7
Fluid Pan, Gasket and Filter	307-01B-138
Fluorescent Dye Leak Detection	412-00-131
Flywheel	303-01A-85



BUY IT NOW!

Click Here To Order



Alphabetical Index

Flywheel — Manual Transmission	303-01B-218	Front Seat Cushion — With Seat Integrated	
Flywheel Check	308-00-20	Restraints (SIR)	501-10-138
Flywheel Runout Check	308-00-20	Front Suspension, Description and Operation	204-01A-3
Fog Lamps	417-01-38	Front Suspension, Description and Operation	204-01B-3
Inspection and Verification	417-01-38	Front Suspension, Diagnosis and Testing	204-01A-4
Pinpoint Tests	417-01-39	Front Suspension — 4x4	204-01B-4
Symptom Chart	417-01-39	Fuel Charging And Controls, Description and	
Forward Clutch Assembly	307-01A-261	Operation	303-04A-2
Forward Clutch Cylinder	307-01B-227	Fuel Charging And Controls, Description and	
Forward Hub and Ring Gear	307-01A-252	Operation	303-04B-2
Forward Planet Assembly	307-01A-272	Fuel Charging And Controls, Description and	
Frame and Body Mounting	502-02-2	Operation	303-04C-2
Frame Maintenance — Drilling Precautions	502-02-8	Fuel Pressure Regulator	303-04C-4
Frame Maintenance — Frame Reinforcing	502-02-10	Fuel Injection Supply Manifold	303-04C-6
Frame Maintenance — Frame Straightening	502-02-9	Fuel Injectors	303-04C-6
Frame Maintenance — Rivet Removal	502-02-7	Fuel Shutoff Valve Solenoid	303-04C-6
Frame Maintenance — Rivet Replacement	502-02-8	Fuel Charging Wiring	303-04C-7
Frame Maintenance — Welding Precautions	502-02-9	Fuel Pressure Relief Valve	303-04C-7
Front Case Bushings	307-01A-228	Injection Pressure Sensor	303-04C-7
Front Disc Brake, Description and Operation	206-03-3	Fuel Temperature Sensor	303-04C-7
Front Disc Brake, Diagnosis and Testing	206-03-5	Fuel Charging And Controls, Description and	
Front Door Latch	501-14-67	Operation	303-04D-3
Front Door Latch — SuperCrew	501-14-69	Fuel Charging And Controls, Diagnosis and	
Front Door Trim Panel	501-05-4	Testing	303-04A-2
Front Door Window Glass	501-11-57	Fuel Charging And Controls, Diagnosis and	
Front Door Window Regulator	501-11-64	Testing	303-04B-3
Front Door Window Regulator Motor	501-11-61	Fuel Charging And Controls, Diagnosis and	
Front Drive Axle	205-03-6	Testing	303-04C-9
Front Drive Axle and Differential	205-03-3	Fuel Charging And Controls, Diagnosis and	
Front Drive Halfshafts, Description and Operation	205-04-2	Testing	303-04D-6
Front Drive Halfshafts, Diagnosis and Testing	205-04-3	Fuel Charging Wiring Harness, Removal and	
Front End Body Panels	501-02-3	Installation	303-04A-6
Front Safety Belt Retractor — Seat Integrated		Fuel Charging Wiring Harness, Removal and	
Restraint (SIR), SuperCab	501-20A-40	Installation	303-04B-8
Front Seat — 40 Percent and Captain's Chair	501-10-72	Fuel Charging Wiring Harness — Supercharged	
Front Seat — 60 Percent	501-10-71	Engines	303-04B-17
Front Seat — Full Bench	501-10-70	Fuel Heater — Vaporizer	303-04D-39
Front Seat — With Seat Integrated Restraints		Fuel Injection Supply Manifold, Removal and	
(SIR)	501-10-74	Installation	303-04A-10
Front Seat Backrest — 40 Percent and Captain's		Fuel Injection Supply Manifold, Removal and	
Chair	501-10-150	Installation	303-04B-23
Front Seat Backrest — 60 Percent	501-10-149	Fuel Injection Supply Manifold — Liquid Propane	
Front Seat Backrest — Front Bench	501-10-147	Gas	303-04D-16
Front Seat Backrest — Seat Integrated Restraints		Fuel Injection Supply Manifold — Natural Gas	303-04D-22
(SIR), Disassembly and Assembly	501-10-153	Fuel Injectors, Removal and Installation	303-04A-4
Front Seat Backrest — Seat Integrated Restraints		Fuel Injectors, Removal and Installation	303-04B-6
(SIR), Removal and Installation	501-10-90	Fuel Injectors, Removal and Installation	303-04C-11
Front Seat Cushion — 40 Percent and Captain's		Fuel Injectors — Liquid Propane Gas	303-04D-10
Chair	501-10-135	Fuel Injectors — Natural Gas	303-04D-13
Front Seat Cushion — 60 Percent	501-10-134	Fuel Line Evacuation	310-00B-7
Front Seat Cushion — Front Bench	501-10-132	Fuel Line Fittings — Push Connect	310-00A-9
Front Seat Cushion — Seat Integrated Restraints		Fuel Pressure Regulator, Removal and	
Chair	501-10-107	Installation	303-04A-12



BUY IT NOW!

Click Here To Order



Alphabetical Index

Fuel Pressure Regulator, Removal and Installation	303-04B-35	Gear — Power Steering	211-02-21
Fuel Pressure Regulator — Natural Gas	310-01C-19	Geartrain	307-01B-19
Fuel Pressure Relief Valve	303-04A-14	Generator, Description and Operation	414-02-2
Fuel System, Description and Operation	310-00A-3	Generator, Diagnosis and Testing	414-02-2
Fuel System, Description and Operation	310-00B-2	Generator — 4.2L	414-02-2
Coalescer/Filter	310-00B-2	Generator — 4.6L and 5.4L	414-02-3
Typical Vent Stack Installation	310-00B-3	Generator — Lightning	414-02-4
Fuel System, Diagnosis and Testing	310-00A-4	Glass, Frames And Mechanisms, Description and Operation	501-11-2
Fuel System, Diagnosis and Testing	310-00B-3	Window Glass — Rear Side	501-11-2
Fuel System — Bi-Fuel Systems	310-00C-5	Windshield Glass	501-11-2
Fuel System — Lightning	310-00A-4	Window Glass — Rear Door—SuperCrew	501-11-2
Fuel System — Liquid Propane Gas	310-00C-3	Window Glass — Back	501-11-2
Fuel System — Natural Gas	310-00C-4	Glass, Frames And Mechanisms, Diagnosis and Testing	501-11-3
Fuel System Leak Test	310-00B-27	Principles of Operation:	501-11-3
Fuel System Service Precautions	303-04C-10	Inspection and Verification	501-11-3
Fuel System Service Precautions — Liquid Propane Gas	303-04D-7	Pinpoint Tests	501-11-10
Fuel System Service Precautions — Natural Gas	303-04D-9	Symptom Chart	501-11-10
Fuel Tank And Lines, Description and Operation	310-01A-3	Glass, Frames And Mechanisms — Window Regulator Control	501-11-2
Fuel Tank And Lines, Description and Operation	310-01B-3	Glove Compartment	501-12-33
Coalescer/Filter	310-01B-4	Grille Opening Panel Reinforcement	501-02-11
Fuel Filler Valve	310-01B-4		
Fuel Tank Straps	310-01B-4		
Fuel Tanks and Solenoid Valves	310-01B-4		
Fuel Lines	310-01B-4		
Fuel Tank And Lines, Description and Operation	310-01C-2		
Fuel Tank And Lines, Diagnosis and Testing	310-01A-4		
Fuel Tank And Lines, Diagnosis and Testing	310-01B-5		
Inspection and Verification	310-01B-5		
Pinpoint Test	310-01B-5		
Symptom Chart	310-01B-5		
Fuel Tank And Lines, Diagnosis and Testing	310-01C-2		
Fuel Tank Draining	310-00A-5		
Fuel Tank Evacuation — Liquid Propane Gas	310-00C-11		
Fuel Tank Evacuation — Natural Gas	310-00C-13		
Fuel Tank Inspection, General Procedures	310-00B-28		
Fuel Tank Inspection, General Procedures	310-00C-23		
Fuel Tank Pressure Sensor, Removal and Installation	310-01B-49		
Fuel Tank Pressure Sensor, Removal and Installation	310-01C-22		
Fuel Tank Temperature Sensor	310-01B-48		
Fuel Tank Temperature Sensor — Natural Gas	310-01C-22		

G

Gauges And Warning Devices — GEM/CTM	413-09-2
Principles of Operation	413-09-3
Inspection and Verification	413-09-5
Pinpoint Test	413-09-9
Symptom Chart	211-02-17

H

Halfshaft, Disassembly and Assembly	205-04-5
Halfshaft, Removal and Installation	205-04-3
Handles, Locks, Latches And Mechanisms	501-14-3
Anti-Scan Feature	501-14-4
Keyless Entry	501-14-4
Autolock Enable/Disable — Using the Ignition Switch	501-14-5
Deactivating/Activating Power Door Unlock Switch Inhibit	501-14-5
Power Unlock Inhibit	501-14-5
Autolock Enable/Disable — Using the Keypad	501-14-5
Headlamp Adjustment	417-01-64
Headlamp Aiming	417-01-64
Photometric Aiming	417-01-65
Screen Method Aiming	417-01-65
Mechanical Aiming	417-01-67
Headlamps	417-01-2
Inspection and Verification	417-01-2
Symptom Chart	417-01-3
Pinpoint Tests	417-01-4
Headliner	501-05-11
Heated Oxygen Sensor (HO2S) — Front	303-14-26
Heated Oxygen Sensor (HO2S) — Front LH — Supercharged Engines	303-14-31
Heated Oxygen Sensor (HO2S) — Front RH — Supercharged Engines	303-14-29



BUY IT NOW!

Click Here To Order



Alphabetical Index

<p>Heated Oxygen Sensor (HO2S) — Rear 303-14-28</p> <p>Heated Oxygen Sensor (HO2S) — Rear LH — Supercharged Engines..... 303-14-32</p> <p>Heated Oxygen Sensor (HO2S) — Rear RH — Supercharged Engines..... 303-14-30</p> <p>Heated Seat Module — Seat Integrated Restraints (SIR) 501-10-115</p> <p>Heated Seat Switch — Seat Integrated Restraints (SIR) 501-10-86</p> <p>Heater Core 412-02-5</p> <p>Heater Core Backflushing 303-03A-28</p> <p>Heater Hose Coupling 412-00-123</p> <p>Heating and Ventilation 412-02-2</p> <p>Heating/Defrosting 412-02-2</p> <p>Height Adjuster — Shoulder Safety Belt, Regular Cab 501-20A-66</p> <p>Hinge Adjustment — Front Door, Fore and Aft 501-03-3</p> <p>Hinge Adjustment — Front Door, Horizontal and Vertical 501-03-2</p> <p>Hinge Adjustment — Rear Door 501-03-4</p> <p>Hinge Adjustment — Rear Door, SuperCrew 501-03-5</p> <p>Hood Alignment — Horizontal 501-02-4</p> <p>Hood Latch 501-14-66</p> <p>Hood Latch Release Handle 501-14-80</p> <p>Horn, Description and Operation 413-06-2</p> <p>Horn, Diagnosis and Testing 413-06-2</p> <p>Inspection and Verification 413-06-2</p> <p>Pinpoint Tests 413-06-3</p> <p>Symptom Chart 413-06-3</p> <p>Hose 211-02-14</p> <p>Hydraulic Brake Actuation, Description and Operation 206-06-2</p> <p>Hydraulic Brake Actuation, Diagnosis and Testing 206-06-4</p> <p>Hydraulic Control Unit (HCU) 206-09B-49</p> <p>Hydraulic Lash Adjuster 303-01B-140</p> <p>Hydraulic Leak Check 206-00-29</p> <p>Hydraulic System 307-01B-25</p> <p>Hydraulic Tubes 308-02-11</p> <div style="border: 1px solid black; width: 100px; height: 100px; margin: 10px auto; text-align: center; line-height: 100px; font-size: 2em; font-weight: bold;">I</div> <p>Identification Codes 100-01-2</p> <p>Identification Tags, Description and Operation 307-01A-8</p> <p>Identification Tags, Description and Operation 307-01B-6</p> <p>Idle Air Control (IAC) Valve — 4.2L 303-14-15</p> <p>Idle Air Control (IAC) Valve — 4.6L and 5.4L 303-14-16</p> <p>Idle Air Control (IAC) Valve — Supercharged Engines 303-14-18</p> <p>Idle Speed Adjustment 303-04C-9</p> <p>Idle Speed Adjustment — Supercharged Engines 303-04B-3</p> <p>Ignition Coil-On-Plug 303-07B-3</p> <p>Ignition Switch 211-05-17</p> <p>Ignition Switch Lock Cylinder — Functional Lock Cylinder 211-04-32</p> <p>Ignition Switch Lock Cylinder — Non-Functional Lock Cylinder 211-04-33</p> <p>Ignition System 303-07B-2</p> <p>In-Car Temperature Sensor 412-04-16</p> <p>Indicator Switch — Shift Range Selector 308-07B-10</p> <p>Input Shaft Bearing 308-03-38</p> <p>Input Shell 307-01A-273</p> <p>Inspection and Repair After a Supplemental Restraint System (SRS) Deployment 501-20B-115</p> <p>Instrument Cluster, Description and Operation 413-01A-2</p> <p>Instrument Cluster, Description and Operation 413-01C-2</p> <p>Instrument Cluster, Diagnosis and Testing 413-01A-5</p> <p>Principles of Operation 413-01A-5</p> <p>Inspection and Verification 413-01A-7</p> <p>Symptom Chart 413-01A-11</p> <p>Pinpoint Tests 413-01A-14</p> <p>Instrument Cluster, Diagnosis and Testing 413-01B-2</p> <p>Diagnostic Instructions 413-01B-4</p> <p>Principles of Operation 413-01B-4</p> <p>Inspection and Verification 413-01B-6</p> <p>Pinpoint Tests 413-01B-11</p> <p>Symptom Chart 413-01B-11</p> <p>Instrument Cluster, Diagnosis and Testing 413-01C-2</p> <p>Principles of Operation 413-01C-2</p> <p>Inspection and Verification 413-01C-3</p> <p>Symptom Chart 413-01C-6</p> <p>Pinpoint Tests 413-01C-7</p> <p>Instrument Cluster, Removal and Installation 413-01A-83</p> <p>Instrument Cluster — Natural Gas Vehicle 413-01B-2</p> <p>Instrument Panel, Description and Operation 501-12-2</p> <p>Instrument Panel, Removal and Installation 501-12-3</p> <p>Instrument Panel — Cluster Panel 501-12-30</p> <p>Instrument Panel — Steering Column Cover 501-12-28</p> <p>Instrument Panel Illumination, Description and Operation 413-00-2</p> <p>Instrument Panel Illumination, Diagnosis and Testing 413-00-2</p> <p>Inspection and Verification 413-00-2</p> <p>Symptom Chart 413-00-2</p> <p>Principles of Operation 413-00-2</p> <p>Pinpoint Tests 413-00-3</p> <p>Insulation 501-00-2</p> <p>Intake Air Distribution And Filtering, Description and Operation 303-12-2</p> <p>Intake Air Distribution And Filtering, Diagnosis and Testing 303-12-6</p> <p>Intake Air Distribution And Filtering — Supercharger 303-12-7</p> <p>Intake Air Distribution And Filtering — Supercharger, Charge Air Cooler 303-12-4</p>	<p>Ignition Coil-On-Plug 303-07B-3</p> <p>Ignition Switch 211-05-17</p> <p>Ignition Switch Lock Cylinder — Functional Lock Cylinder 211-04-32</p> <p>Ignition Switch Lock Cylinder — Non-Functional Lock Cylinder 211-04-33</p> <p>Ignition System 303-07B-2</p> <p>In-Car Temperature Sensor 412-04-16</p> <p>Indicator Switch — Shift Range Selector 308-07B-10</p> <p>Input Shaft Bearing 308-03-38</p> <p>Input Shell 307-01A-273</p> <p>Inspection and Repair After a Supplemental Restraint System (SRS) Deployment 501-20B-115</p> <p>Instrument Cluster, Description and Operation 413-01A-2</p> <p>Instrument Cluster, Description and Operation 413-01C-2</p> <p>Instrument Cluster, Diagnosis and Testing 413-01A-5</p> <p>Principles of Operation 413-01A-5</p> <p>Inspection and Verification 413-01A-7</p> <p>Symptom Chart 413-01A-11</p> <p>Pinpoint Tests 413-01A-14</p> <p>Instrument Cluster, Diagnosis and Testing 413-01B-2</p> <p>Diagnostic Instructions 413-01B-4</p> <p>Principles of Operation 413-01B-4</p> <p>Inspection and Verification 413-01B-6</p> <p>Pinpoint Tests 413-01B-11</p> <p>Symptom Chart 413-01B-11</p> <p>Instrument Cluster, Diagnosis and Testing 413-01C-2</p> <p>Principles of Operation 413-01C-2</p> <p>Inspection and Verification 413-01C-3</p> <p>Symptom Chart 413-01C-6</p> <p>Pinpoint Tests 413-01C-7</p> <p>Instrument Cluster, Removal and Installation 413-01A-83</p> <p>Instrument Cluster — Natural Gas Vehicle 413-01B-2</p> <p>Instrument Panel, Description and Operation 501-12-2</p> <p>Instrument Panel, Removal and Installation 501-12-3</p> <p>Instrument Panel — Cluster Panel 501-12-30</p> <p>Instrument Panel — Steering Column Cover 501-12-28</p> <p>Instrument Panel Illumination, Description and Operation 413-00-2</p> <p>Instrument Panel Illumination, Diagnosis and Testing 413-00-2</p> <p>Inspection and Verification 413-00-2</p> <p>Symptom Chart 413-00-2</p> <p>Principles of Operation 413-00-2</p> <p>Pinpoint Tests 413-00-3</p> <p>Insulation 501-00-2</p> <p>Intake Air Distribution And Filtering, Description and Operation 303-12-2</p> <p>Intake Air Distribution And Filtering, Diagnosis and Testing 303-12-6</p> <p>Intake Air Distribution And Filtering — Supercharger 303-12-7</p> <p>Intake Air Distribution And Filtering — Supercharger, Charge Air Cooler 303-12-4</p>
--	---



BUY IT NOW!

Click Here To Order



Alphabetical Index

Intake Air Temperature (IAT) Sensor.....	303-14-23
Intake Air Temperature (IAT) Sensor — Air Cleaner — Supercharged Engines.....	303-14-26
Intake Air Temperature (IAT) Sensor — Intake Manifold — Supercharged Engines.....	303-14-24
Intake Manifold — 4.6L.....	303-01B-29
Intake Manifold — 5.4L.....	303-01B-46
Intake Manifold — Spacer Assembly.....	303-01A-26
Intake Manifold — Supercharged Engines.....	303-01B-64
Intake Manifold Assembly — 4.6L.....	303-01B-275
Intake Manifold Assembly — 5.4L.....	303-01B-281
Interior Door Handle — Front.....	501-14-86
Interior Door Handle — Rear, F-150.....	501-14-88
Interior Door Handle — Rear, SuperCrew.....	501-14-87
Interior Lighting.....	417-02-2
Interior Lighting — GEM/CTM.....	417-02-2
Principles of Operation.....	417-02-2
GEM Diagnostic Trouble Code (DTC) Index.....	417-02-3
Inspection and Verification.....	417-02-3
Symptom Chart.....	417-02-4
Pinpoint Tests.....	417-02-5
Interior Trim.....	501-05-2
Intermediate One-Way Clutch.....	307-01B-217
Intermediate Servo.....	307-01A-176
Intermediate/Overdrive Cylinder Assembly.....	307-01A-246

J

Jacking.....	100-02-2
--------------	----------

K

Key Programming — Additional Key With One Programmed Key.....	419-01-37
Key Programming — Enable/Disable Spare Key Programming.....	419-01-36
Key Programming — Erase All Key Codes and Program Two Keys.....	419-01-34
Key Programming — Program a Key Using Two Programmed Keys.....	419-01-33
Key Release Button.....	211-05-19
Keyless Entry Keypad.....	501-14-96
Keyless Entry Keypad Code Programming.....	501-14-66
Knock Sensor (KS) — 4.2L.....	303-14-33
Knock Sensor (KS) — 4.6L and 5.4L.....	303-14-33
Knuckle — Front Wheel.....	204-01B-22

L

Lamp Assembly — Fog Lamp.....	417-01-72
Lamp Assembly — Map.....	417-02-42
Lamp Assembly — Signal Mirrors.....	417-01-74
Lamp Switch — Brake Pedal Position (BPP).....	417-01-76
Lamp Switch — Headlamp.....	417-01-75
Leak Test — Bi-Fuel System.....	310-00C-20
Leak Test — Evaporative Emission System.....	303-13-34
Leakage Inspection.....	307-01B-97
Lifting.....	100-02-3
Lifting Points — Twin Post Hoist.....	100-02-3
Line — 4.2L.....	412-03-44
Line — 4.6L and 5.4L.....	412-03-46
Lines — Front High-Pressure Fuel.....	310-01B-42
Lines — Low-Pressure Fuel.....	310-01B-44
Lines — Rear High-Pressure Fuel.....	310-01B-40
Locks, Latches and Entry Systems — Module	
Controlled Vehicles.....	501-14-17
Principles of Operation.....	501-14-17
Inspection and Verification.....	501-14-18
Symptom Chart.....	501-14-19
Pinpoint Tests.....	501-14-20
Locks, Latches and Entry Systems — Non Module Controlled.....	501-14-6
Inspection and Verification.....	501-14-6
Symptom Chart.....	501-14-6
Pinpoint Tests.....	501-14-7
Low One-Way Clutch Assembly.....	307-01A-275
Lower Intake Manifold.....	303-01A-19

M

Main Components and Functions, Description and Operation.....	307-01A-20
Torque Converter.....	307-01A-20
Geartrain.....	307-01A-21
Main Components and Functions, Description and Operation.....	307-01B-18
Main Control Valve Body, Disassembly and Assembly of Subassemblies.....	307-01B-203
Main Control Valve Body, In-Vehicle Repair.....	307-01B-144
Main Control Valve Body — Accumulator Body Check.....	307-01A-215
Main Control Valve Body — Accumulator Body, Solenoid Body.....	307-01A-145
Main Control Valve Body — Disassembly and Assembly.....	307-01A-208
Main Control Valve Body — Solenoid Body Check.....	307-01A-214
Manifold And Tube Assembly — 4.2L.....	412-03-40
Manifold And Tube Assembly — 4.6L and 5.4L.....	412-03-42



Alphabetical Index

Manifold Gauge Set Connection 412-00-128

Manual Control Lever Shaft and Seal, In-Vehicle
Repair 307-01A-165

Manual Control Lever Shaft and Seal, In-Vehicle
Repair 307-01B-156

Manual Transmission, Description and Operation 308-03-2

Manual Transmission, Diagnosis and Testing 308-03-4

Manual Transmission and Clutch, Description and
Operation 308-00-2

Manual Transmission and Clutch, Diagnosis and
Testing 308-00-3

Symptom Chart 308-00-3

Mass Air Flow (MAF) Sensor 303-14-20

Mass Air Flow (MAF) Sensor — Supercharged
Engines 303-14-22

Master Cylinder, Disassembly and Assembly 206-06-29

Master Cylinder, Removal and Installation 206-06-25

Meshload Adjustment 211-00-18

Mirror — Cover, Exterior Rear View Mirror 501-09-17

Mirror — Glass, Exterior Rear View Mirror 501-09-19

Mirror — Inside Rear View, Bracket 501-09-23

Mirror — Interior Mirror 501-09-22

Module — Anti-Lock Brake Control 206-09A-49

Module — Central Security Module (CSM) 419-10-24

Module — Driver Air Bag 501-20B-164

Module — Generic Electronic (GEM)/Central
Timer (CTM) 419-10-22

Module — Natural Gas Vehicle (NGV) 413-01B-54

Module — Passenger Air Bag 501-20B-172

Module — Passive Anti-Theft Transceiver 419-01-39

Module — Restraints Control 501-20B-160

Module Configuration 418-01-2

Principles of Operation 418-01-2

Inspection and Verification 418-01-3

Module Controlled Functions 419-10-2

Motor 501-16-63

Mounting Arm and Pivot Shaft — Windshield
Wiper 501-16-60

Multifunction Switch 211-05-15

**Noise, Vibration And Harshness (NVH),
Diagnosis and Testing (Continued)**

3: Preparing for the Road Test 100-04-15

4: Verify the Customer Concern 100-04-15

5: Road Test 100-04-16

6: Check OASIS/TSBs/Repair History 100-04-18

7: Diagnostic Procedure 100-04-18

NVH Condition and Symptom Categories 100-04-19

Symptom Charts 100-04-20

Pinpoint Tests 100-04-57

Component Tests 100-04-90

O

Occupant Restraint System, Description and
Operation 501-20A-4

Seat Integrated Restraints (SIR) 501-20A-4

Pretensioner System 501-20A-4

Dual Locking Mode Retractors 501-20A-5

Safety Belt Extension Assembly 501-20A-5

Safety Belt, Buckle End—Front 501-20A-5

Fastening Safety Belts 501-20A-5

Attaching Safety Seats With Tether Straps 501-20A-6

Warning System — Driver Safety Belt 501-20A-6

Occupant Restraint System, Diagnosis and
Testing 501-20A-7

Inspection and Verification 501-20A-7

Symptom Chart 501-20A-7

Component Test 501-20A-7

Oil Filter Adapter — 4x2 303-01B-164

Oil Filter Adapter — 4x4 303-01B-168

Oil Level Indicator and Tube, In-Vehicle Repair 303-01A-75

Oil Level Indicator and Tube, In-Vehicle Repair 303-01B-173

Oil Pan — 4x2 303-01A-75

Oil Pan — 4x2, 4.6L 303-01B-174

Oil Pan — 4x2, 5.4L 303-01B-191

Oil Pan — 4x4, In-Vehicle Repair 303-01A-78

Oil Pan — 4x4, In-Vehicle Repair 303-01B-208

Oil Pump, In-Vehicle Repair 303-01A-82

Oil Pump, In-Vehicle Repair 303-01B-212

Oil Pump Screen and Pickup Tube, In-Vehicle
Repair 303-01A-84

Oil Pump Screen and Pickup Tube, In-Vehicle
Repair 303-01B-215

Output Shaft 308-03-39

Output Shaft — Check 307-01A-269

Output Shaft and Direct Clutch Cylinder 307-01B-237

Output Shaft Speed Sensor 308-07B-11

Output State Control (OSC) Mode, Diagnosis and
Testing 307-01A-38

Output State Control (OSC) Mode, Diagnosis and
Testing 307-01B-40

N

Noise, Vibration And Harshness (NVH),
Description and Operation 100-04-2

Acceptable Noise, Vibration and Harshness 100-04-2

Diagnostic Theory 100-04-2

Glossary of Terms 100-04-2

Tools and Techniques 100-04-7

Noise, Vibration And Harshness (NVH), Diagnosis
and Testing 100-04-11

..... 100-04-15

..... 100-04-15



BUY IT NOW!

Click Here To Order



Alphabetical Index

Overdrive Ring Gear and Center Shaft Assembly307-01A-241
 Overdrive Servo307-01B-169

P

Pads, Removal and Installation 206-03-5
 Pads, Removal and Installation 206-04-6
 Panel 501-04-2
 Park System307-01A-177
 Parking Brake, Description and Operation 206-05-3
 Rear Disc Brakes 206-05-4
 Parking Brake, Diagnosis and Testing 206-05-5
 Symptom Chart 206-05-5
 Inspection and Verification 206-05-5
 Parking, Rear and License Lamps 417-01-31
 Inspection and Verification 417-01-31
 Pinpoint Tests 417-01-32
 Symptom Chart 417-01-32
 Passenger Air Bag Deactivation (PAD) Switch 501-20B-193
 Pedal and Bracket — Adjustable 206-06-9
 Pedal and Bracket — Fixed, Automatic
 Transmission 206-06-4
 Pedal and Bracket — Fixed, Manual
 Transmission 206-06-6
 Pickup Bed, Description and Operation 501-04-2
 Pickup Bed, Removal and Installation 501-04-7
 Pinion Seal 205-02C-20
 Pinpoint Tests — Air Bag and Safety Belt
 Pretensioner Supplemental Restraint System
 (SRS) 501-20B-13
 Pinpoint Tests — OSC Equipped Vehicles 307-01B-57
 Piston 303-01A-109
 Piston — Pin Connecting Rod, Floating Pin 303-01B-272
 Piston — Pin Connecting Rod, Press Fit 303-01B-270
 Piston — Diameter 303-00-30
 Piston — Pin Diameter 303-00-33
 Piston — Pin to Bore Diameter 303-00-29
 Piston — Ring End Gap 303-00-31
 Piston — Ring-to-Groove Clearance 303-00-32
 Piston — Selection 303-00-31
 Piston — to Cylinder Bore Clearance 303-00-30
 Piston Inspection 303-00-28
 Pivot Arm 501-16-60
 Planetary Gear Support Assembly and Planetary
 One-Way Clutch 307-01B-235
 Plenum Chamber 412-01-8
 Power Brake System 206-07-2
 Power Steering, Description and Operation 211-02-2
 Power Steering Pump 211-02-3
 Power Steering Servo 211-02-3
 Power Steering Valve 211-02-5
 Rack and Pinion 211-02-5

Power Steering, Diagnosis and Testing 211-02-5
 Powertrain Control Module (PCM) 303-14-12
 Powertrain/Drivetrain Mount Neutralizing 100-04-97
 Preliminary Inspection, Diagnosis and Testing 307-01A-33
 Know/Understand the Concern 307-01A-33
 Verification of Condition 307-01A-33
 Visual Inspection 307-01A-37
 Preliminary Inspection, Diagnosis and Testing 307-01B-32
 Pressure Cutoff Switch 412-03-36
 Pressure Plate Adjustment 308-00-21
 Pressure Plate Check 308-00-20
 Pressure Regulator — Fuel 303-04C-25
 Pressure Relief 310-00A-4
 Pressure Relief — Fuel Rail Tuning Adjustment 310-00C-30
 Pressure Relief — Fuel Tank Venting 310-00B-10
 Pressure Relief — Liquid Propane Gas Bi-Fuel
 System 310-00C-6
 Pressure Relief — Natural Gas Bi-Fuel System 310-00C-9
 Pressure Relief Valve 303-04B-37
 Pressure Relief Valve — 4.2L 412-03-37
 Pressure Relief Valve — 4.6L and 5.4L 412-03-37
 Pressure Relief Valve — Fuel 303-04C-29
 Pressure Sensor — Fuel Tank 303-13-43
 Programming 419-02-4
 Training a Garage Door Opener Equipped With
 "Rolling Codes" 419-02-5
 Erasing Channels 419-02-6
 Pulley — Pump, In-Vehicle, Lightning Vehicles 211-02-13
 Pulley — Pump, On-Bench 211-02-12
 Pump, Removal and Installation 310-01A-15
 Pump, Removal and Installation 211-02-8
 Pump — Lightning 310-01A-16
 Pump and Intermediate Clutch Piston 307-01B-211
 Pump Assembly 307-01A-216
 Purging 211-00-13
 Push Rod Adjustment 206-07-2
 Push Rods — Cleaning 303-00-19
 Push Rods — Inspection 303-00-19

R

Radiator, Removal and Installation 303-03A-37
 Radiator, Removal and Installation 303-03B-16
 Radiator Grille 501-08-2
 Radiator Grille — Bumper Cover 501-08-4
 Range Selection, Description and Operation 307-01A-8
 Range Selection, Description and Operation 307-01B-6
 Rear Case Bushings 307-01A-230
 Rear Disc Brake, Description and Operation 206-04-3
 Rear Disc Brake, Diagnosis and Testing 206-04-3
 Rear Door Latch — Lower 501-14-72
 Rear Door Latch — SuperCrew 501-14-75



BUY IT NOW!

Click Here To Order



Alphabetical Index

Rear Door Latch — Upper	501-14-73	Rear Wheel Bearing and Axle Shaft Oil Seal, In-Vehicle Repair	205-02A-9
Rear Door Trim Panel — SuperCrew	501-05-10	Rear Wheel Bearing and Axle Shaft Oil Seal, In-Vehicle Repair	205-02B-9
Rear Door Window Glass — SuperCrew	501-11-59	Rear Wheel Bearing and Axle Shaft Oil Seal — Disc Brake	205-02C-12
Rear Door Window Regulator — SuperCrew	501-11-66	Rear Wheel Bearing and Axle Shaft Oil Seal — Drum Brake	205-02C-14
Rear Door Window Regulator Motor — SuperCrew	501-11-62	Refrigerant Identification Testing	412-00-147
Rear Drive Axle and Differential, Description and Operation	205-02A-3	Refrigerant Oil Adding	412-00-146
Rear Drive Axle and Differential, Description and Operation	205-02B-3	Refrigerant System Filtering Following Air Conditioning (A/C) Component Installation	412-00-142
Rear Drive Axle and Differential, Description and Operation	205-02C-3	Refrigerant System Tests	412-00-125
Rear Drive Axle and Differential, Diagnosis and Testing	205-02A-5	Register — Center	412-01-4
Rear Drive Axle and Differential, Diagnosis and Testing	205-02B-6	Register — LH	412-01-3
Rear Drive Axle and Differential, Diagnosis and Testing	205-02C-5	Register — RH	412-01-5
Rear Footwell Duct	412-01-7	Remote Transmitter Programming	501-14-65
Rear Safety Belt Retractor — Center, SuperCrew	501-20A-51	Replacement of the Weld Nut and Reinforcement	501-20A-35
Rear Safety Belt Retractor — Outboard, SuperCrew	501-20A-51	Reservoir	206-06-27
Rear Seat — 40 Percent and Quad Bucket, SuperCrew	501-10-79	Reservoir — 4.2L Engine	211-02-5
Rear Seat — 60 Percent, SuperCrew	501-10-78	Reservoir — 4.6L and 5.4L Engines	211-02-7
Rear Seat — SuperCab	501-10-78	Retractor — Rear, SuperCab	501-20A-39
Rear Seat Backrest — 40 Percent and Quad Bucket, SuperCrew, Disassembly and Assembly	501-10-163	Reverse Clutch	307-01B-218
Rear Seat Backrest — 40 Percent and Quad Bucket, SuperCrew, Removal and Installation	501-10-97	Reverse Clutch Piston	307-01A-277
Rear Seat Backrest — SuperCab	501-10-161	Reverse Idler Gear	308-03-45
Rear Seat Backrest — SuperCrew 60 Percent, Disassembly and Assembly	501-10-162	Reverse Planet Assembly	307-01A-274
Rear Seat Backrest — SuperCrew 60 Percent, Removal and Installation	501-10-95	Reverse Servo Assembly	307-01B-165
Rear Seat Backrest Latch — SuperCrew	501-10-120	Reverse Sun Gear	307-01B-236
Rear Seat Cushion — 40 Percent and Quad Bucket, SuperCrew	501-10-146	Reversing Lamps	417-01-44
Rear Seat Cushion — 60/40 Bench and Quad Bucket, SuperCrew	501-10-114	Symptom Chart	417-01-44
Rear Seat Cushion — SuperCab	501-10-142	Inspection and Verification	417-01-44
Rear Seat Cushion — SuperCrew 60 Percent	501-10-142	Pinpoint Tests	417-01-45
Rear Suspension, Description and Operation	204-02-2	Ride Height	204-01B-4
Rear Axle Bumpers	204-02-4	Ring Gear	308-01-7
Suspension Fasteners	204-02-4	Road Testing Vehicle	307-01B-34
Shock Absorbers	204-02-4	Rocker Arms — Cleaning	303-00-18
Rear Spring	204-02-4	Rocker Arms — Inspection	303-00-19
Rear Suspension, Diagnosis and Testing	204-02-4	Roller Follower — Inspection	303-00-36
Rear View Mirrors, Description and Operation	501-09-2	Roof Opening Panel, Description and Operation	501-17-2
Rear View Mirrors, Diagnosis and Testing	501-09-2	Roof Opening Panel, Diagnosis and Testing	501-17-2
Inspection and Verification	501-09-2	Inspection and Verification	501-17-2
Pinpoint Tests	501-09-3	Symptom Chart	501-17-3
.....	501-09-3	Pinpoint Tests	501-17-4
.....	501-09-3	Roof Opening Panel, Removal and Installation	501-17-18
.....	501-09-16	Roof Opening Panel Alignment — Height Adjustment	501-17-17
		Roof Opening Panel Alignment — Horizontal Adjustment	501-17-16
		Roof Opening Panel Frame	501-17-20
		Roof Opening Panel Module	501-17-21
		Roof Opening Panel Motor	501-17-18



BUY IT NOW!

Click Here To Order



Alphabetical Index

S

Safety Belt — 60/40 Split and Front Bench Seat, Center Passenger.....	501-20A-64	Seat Track — Manual	501-10-98
Safety Belt — Rear, SuperCab	501-20A-65	Seat Track — Power	501-10-100
Safety Belt Buckle — 40 Percent Portion of 60/40 Split Bench	501-20A-78	Seat Track — With Seat Integrated Restraints	501-10-102
Safety Belt Buckle — 60 Percent Portion of 60/40 Split Bench	501-20A-77	Seats, Description and Operation	501-10-4
Safety Belt Buckle — Bucket Seats	501-20A-74	Rear—CrewCab	501-10-5
Safety Belt Buckle — Full Bench Seat	501-20A-76	Seats, Diagnosis and Testing.....	501-10-5
Safety Belt Buckle — Rear, Left Hand Passenger, SuperCrew	501-20A-81	Inspection and Verification.....	501-10-6
Safety Belt Buckle — Rear, Right Hand and Center Passenger SuperCrew.....	501-20A-81	Principles of Operation.....	501-10-6
Safety Belt Buckle — Rear, SuperCab.....	501-20A-79	Restraint System Diagnostic Tool Warning.....	501-10-6
Safety Belt Buckle and Pretensioner — Seat Integrated Restraints (SIR), SuperCab	501-20A-83	Symptom Chart.....	501-10-7
Safety Belt Cleaning.....	501-20A-35	Pinpoint Tests	501-10-8
Safety Belt Pretensioner Disposal — Deployed	501-20B-121	Sector Shaft Arm — 4x2	211-03-11
Safety Belt Pretensioner Disposal — Undeployed, Inoperative.....	501-20B-122	Sector Shaft Arm — 4x4	211-03-13
Safety Belt Pretensioner Disposal — Undeployed, Scrapped Vehicle	501-20B-123	Sector Shaft Arm Drag Link.....	211-03-9
Safety Belt Buckle Pretensioner Remote Deployment	501-20B-123	Security Access — Procedure	419-01-38
Safety Belt Retractor Pretensioner Remote Deployment	501-20B-125	Selector Lever	307-05-20
Safety Belt Procedure After a Collision	501-20A-38	Sender Unit — 4.2L	303-03A-43
Safety Belt Retractor and Pretensioner — Without Seat Integrated Restraints (SIR)	501-20A-53	Sensor — Front, 4x2	206-09B-53
Safety Belt Shoulder Height Adjuster — Front, SuperCrew.....	501-20A-68	Sensor — Front, 4x4	206-09B-54
Safety Belt Shoulder Height Adjuster — Rear, SuperCrew.....	501-20A-71	Sensor — Fuel Tank Pressure	413-01B-56
Safety Belt Shoulder Height Adjuster With Stripped Weld Nuts	501-20A-36	Sensor — Rear, Removal and Installation	206-09A-49
Safety Belt Tongue Rotated on Belt.....	501-20A-38	Sensor — Rear, Removal and Installation	206-09B-52
Safety Precautions	204-04-2	Sensor — Tank Temperature	413-01B-57
Seal — Oil	308-07B-5	Sensor Indicator	206-09A-50
Seals, Rings and Gasket Locator, Description and Operation	307-01A-18	Sensor Indicator — Front, 4x2.....	206-09B-55
Seals, Rings and Gasket Locator, Description and Operation	307-01B-16	Shaft Seal	412-03-21
Seat — 40 Percent and Captain's Chair	501-10-128	Shield, Removal and Installation.....	206-03-16
Seat — 60 Percent Front Bench	501-10-122	Shield, Removal and Installation.....	206-04-10
Seat — Front Bench	501-10-121	Shift Control Housing.....	308-03-31
Seat — Track, Manual	501-10-131	Shift Lever	308-07B-7
Seat Backrest — Rear Seat	501-10-85	Shift Lever and Boot	308-03-14
Seat Control Switch — Seat Integrated Restraints	501-10-81	Shift Patterns, Description and Operation.....	307-01A-9
Seat Control Switch — Seat Integrated Restraints	501-10-80	Shift Patterns, Description and Operation.....	307-01B-7
Seat Control Switch — Seat Integrated Restraints	501-10-119	Shift Point Road Test.....	307-01B-34
		Shift Switch — 4WD Indicator	308-07B-6
		Shoes	206-02-10
		Shoes — Rear Disc Brakes.....	206-05-13
		Slave Cylinder	308-02-10
		Solenoid — Canister Vent	303-13-44
		Solenoid Valve — Fuel Tank	310-01B-30
		Solenoid Valve — Tank	310-01C-10
		Spacer — Mid-Ship Fuel Tank Mounting	310-01B-32
		Spark Plug, Removal and Installation	303-07A-5
		Spark Plug, Removal and Installation	303-07B-4
		Spark Plug — Inspection.....	303-00-45
		Spark Plug Hole Thread Repair	303-00-45
		Spark Plug Wire	303-07A-4
		Speakers	415-03-2
		Speakers — Door Mounted.....	415-03-2
		Special Testing Procedures.....	307-01B-91
		SPECIFICATIONS	
		Body System — General Information	501-00-2
		Front End Body Panels	501-02-2
		Body Closures.....	501-03-2



BUY IT NOW!

Click Here To Order



Alphabetical Index

SPECIFICATIONS (Continued)

Pickup Bed and Platform Body	501-04-2
Interior Trim and Ornamentation	501-05-2
Exterior Trim and Ornamentation	501-08-2
Rear View Mirrors	501-09-2
Seating	501-10-3
Glass, Frames and Mechanisms	501-11-2
Instrument Panel and Console	501-12-2
Handles, Locks, Latches and Entry Systems	501-14-3
Wipers and Washers	501-16-2
Roof Opening Panel	501-17-2
Bumpers	501-19-2
Occupant Restraints — Active	501-20A-3
Occupant Restraints — Passive — Supplemental Air Bag System	501-20B-3
Full Frame and Body Mounting	502-02-2
Engine System — General Information	303-00-4
Engine — 4.2L	303-01A-2
Engine — 4.6L and 5.4L	303-01B-3
Engine Cooling	303-03A-2
Supercharger Cooling	303-03B-2
Fuel Charging and Controls — 4.2L	303-04A-2
Fuel Charging and Controls — 4.6L (2V) and 5.4L (2V)	303-04B-2
Fuel Charging and Controls — Natural Gas Vehicle	303-04C-2
Fuel Charging and Controls — Bi-Fuel Vehicles	303-04D-2
Accessory Drive	303-05-2
Starting System	303-06-2
Engine Ignition — 4.2L	303-07A-2
Engine Ignition — 4.6L (2V) and 5.4L (2V)	303-07B-2
Engine Emission Control	303-08-2
Intake Air Distribution and Filtering	303-12-2
Evaporative Emissions	303-13-2
Electronic Engine Controls	303-14-2
Suspension System — General Information	204-00-3
Front Suspension — 4x2	204-01A-2
Front Suspension — 4x4	204-01B-2
Rear Suspension	204-02-2
Wheels and Tires	204-04-2
Driveline System — General Information	205-00-2
Driveshaft	205-01-2
Rear Drive Axle/Differential — Ford 8.8-Inch Ring Gear	205-02A-2
Rear Drive Axle/Differential — Ford 9.75-Inch Ring Gear	205-02B-2
Rear Drive Axle/Differential — Ford 10.25-Inch Ring Gear	205-02C-2
Front Drive Axle/Differential — Ford 8.8-Inch Ring Gear	205-03-2
Front Drive Halfshafts	205-04-2
Brake System — General Information	206-00-2
.....	206-02-2
.....	206-03-2

SPECIFICATIONS (Continued)

Rear Disc Brake	206-04-2
Parking Brake and Actuation	206-05-2
Hydraulic Brake Actuation	206-06-2
Power Brake Actuation	206-07-2
Anti-Lock Control — Rear	206-09A-2
Anti-Lock Control — 4-Wheel	206-09B-2
Automatic Transmission — 4R100	307-01A-3
Automatic Transmission — 4R70W	307-01B-3
Transaxle/Transmission Cooling	307-02-2
Automatic Transaxle/Transmission External Controls	307-05-2
Manual Transaxle/Transmission and Clutch — General Information	308-00-2
Clutch	308-01-2
Clutch Controls	308-02-2
Manual Transaxle/Transmission	308-03-2
Transfer Case	308-07B-2
Exhaust System	309-00-2
Fuel System — General Information	310-00A-2
Fuel System — General Information — Natural Gas	310-00B-2
Fuel System — General Information — Bi-Fuel Vehicles	310-00C-2
Fuel Tank and Lines	310-01A-2
Fuel Tank and Lines — Natural Gas	310-01B-2
Fuel Tank and Lines — Bi-Fuel Vehicles	310-01C-2
Acceleration Control	310-02-2
Vehicle Speed Control	310-03-2
Steering System — General Information	211-00-2
Power Steering	211-02-2
Steering Linkage	211-03-2
Steering Column	211-04-2
Steering Column Switches	211-05-2
Climate Control System — General Information	412-00-3
Air Distribution and Filtering	412-01-2
Heating and Ventilation	412-02-2
Air Conditioning	412-03-2
Control Components	412-04-2
Instrument Cluster — Conventional	413-01A-2
Instrument Cluster — Natural Gas Vehicle	413-01B-2
Horn	413-06-2
Battery, Mounting and Cables	414-01-2
Generator and Regulator	414-02-2
Audio Unit	415-01-2
Antenna	415-02-2
Exterior Lighting	417-01-2
Daytime Running Lamps	417-04-2
Module Communications Network	418-00-2
Anti-Theft — PATS	419-01-2
Multifunction Electronic Control Modules	419-10-2
Speed Control Cable	310-03-33
Speed Control Servo	310-03-34
Spindle	204-01A-16



BUY IT NOW!

Click Here To Order



Alphabetical Index

Spring	204-02-8	Supplemental Restraint System (SRS) Deactivation and Reactivation, General Procedures	501-20A-8
Spring — Coil	204-01A-21	Supplemental Restraint System (SRS) Deactivation and Reactivation, General Procedures	501-20B-127
Spring Lock Coupling	412-00-116	Supplemental Restraint System (SRS) Deactivation and Reactivation, General Procedures	211-04-5
Spring Lock Couplings	310-00B-5	Supply Manifold — Fuel Injection	303-04C-16
Spring Lock Couplings — Spring Lock	310-00A-6	Support — Cab	502-02-10
Sprockets	303-00-18	Support Straps	310-01A-13
Starter Drive and Flywheel Ring Gear Inspection	303-06-27	Support Straps — In-Bed Tank Assembly, Upper	310-01B-32
Starter Motor	303-06-29	Support Straps — Mid-Ship Tank	310-01B-32
Starting System, Description and Operation	303-06-2	Suspension System	204-00-7
Starting System, Diagnosis and Testing	303-06-4	Inspection and Verification	204-00-7
Inspection and Verification	303-06-4	Symptom Chart	204-00-8
Symptom Chart	303-06-5	Component Tests	204-00-14
Pinpoint Tests	303-06-6	Switch — Clutch Pedal Position (CPP)	303-06-33
Steering Column, Description and Operation	211-04-3	Switch — Deactivator	310-03-36
Steering Column, Diagnosis and Testing	211-04-5	Switch — Door Open Warning Lamp	413-09-30
Steering Column — Manual Transmission	211-04-42	Switch — Relay Solenoid	303-06-27
Steering Column — Automatic Transmission	211-04-57	Switch — Speed Control Actuator	310-03-35
Steering Column Shaft	211-04-41	Switches	412-04-11
Steering Column Switches, Description and Operation	211-05-3	Synchronizer — Camshaft, 4.2L	303-14-6
Steering Column Switches, Diagnosis and Testing	211-05-4	Synchronizers	308-03-46
Inspection and Verification	211-05-4	System Flushing	211-00-10
Symptom Chart	211-05-8		
Pinpoint Tests	211-05-9		
Component Test	211-05-15		
Steering Linkage, Description and Operation	211-03-3		
Steering Linkage, Diagnosis and Testing	211-03-3		
Steering System, Description and Operation	211-00-3		
Steering System, Diagnosis and Testing	211-00-4		
Inspection and Verification	211-00-4		
Symptom Chart	211-00-6		
Component Tests	211-00-8		
Stoplamps	417-01-22		
Symptom Chart	417-01-22		
Inspection and Verification	417-01-22		
Pinpoint Tests	417-01-23		
Suction Accumulator — 4.2L	412-03-30		
Suction Accumulator — 4.6L and 5.4L	412-03-32		
Sunload Sensor	412-04-18		
Supercharger Bypass Vacuum Solenoid	303-14-37		
Supercharger Bypass Vacuum Solenoid — Actuator	303-14-38		
Supercharger Cooling, Description and Operation	303-03B-2		
Supercharger Cooling, Diagnosis and Testing	303-03B-3		
Inspection and Verification	303-03B-4		
Pinpoint Tests	303-03B-6		
Symptom Chart	303-03B-6		
Component Tests	303-03B-8		
Supercharger Cooling System Draining, Filling and Bleeding	303-03B-11		
Supercharger Cooling System Flushing	303-03B-14		
Supplemental Restraint System (SRS) Procedures	501-10-43		

T

Tailgate Latch	501-14-78
Tailgate Latch Remote Control	501-14-93
Tailgate Lock Cylinder	501-14-90
Tailgate Release Handle	501-14-89
Tank — Compressed Natural Gas (CNG)	310-01C-7
Tank — Forward In-Bed	310-01B-23
Tank — Fuel	310-01A-4
Tank — Fuel, Lightning	310-01A-9
Tank — Liquefied Petroleum Gas (LPG)	310-01C-3
Tank — Midship	310-01B-17
Tank — Rear In-Bed	310-01B-27
Tank Inspection — Purging	310-00C-28
Temperature Blend Door Actuator	412-04-12
Thermostat — 4.2L	303-03A-30
Thermostat — 4.6L and 5.4L	303-03A-31
Throttle Body, Removal and Installation	303-04A-3
Throttle Body, Removal and Installation	303-04B-3
Throttle Body — Supercharged Engines	303-04B-5
Throttle Position (TP) Sensor — 4.2L	303-14-13
Throttle Position (TP) Sensor — 4.6L and 5.4L	303-14-14
Throttle Position (TP) Sensor — Supercharged Engines	303-14-15

100% SATISFACTION GUARANTEED

BUY IT NOW!

Click Here To Order

Alphabetical Index

Tie Rod End — Inner.....	211-03-4	Transfer Case, Description and Operation.....	308-07A-2
Tie Rod End — Outer.....	211-03-6	Transfer Case, Description and Operation.....	308-07B-2
Tie Rod End — Adjusting Sleeve.....	211-03-8	Transfer Case, Diagnosis and Testing.....	308-07B-4
Timing Chain — Tensioner.....	303-01A-58	Transfer Case, Disassembly and Assembly.....	308-07B-12
Timing Drive Components — Romeo Engine.....	303-01B-128	Transfer Case, Installation.....	308-07B-51
Timing Drive Components — Windsor Engine.....	303-01B-116	Transfer Case — 4R100 Transmission.....	308-07B-45
Toe Adjustment.....	204-00-18	Transfer Case — 4R70W Transmission.....	308-07B-40
Tonneau Cover.....	501-00-4	Transfer Case — Electronic Shift on the Fly (ESOF) Features.....	308-07A-4
Tonneau Cover — Side Rail.....	501-04-10	Transfer Case — Electronic Shift on the Fly (ESOF) Operation.....	308-07A-3
Tonneau Cover — Side Rail End Cap.....	501-04-11	Transfer Case — ESOF.....	308-07A-4
Torque Converter, Description and Operation.....	307-01B-18	Inspection and Verification — Electronic Shift on the Fly (ESOF).....	308-07A-7
Torque Converter, Disassembly and Assembly of Subassemblies.....	307-01A-278	Symptom Chart — Electronic Shift on the Fly (ESOF).....	308-07A-11
Torque Converter, Disassembly and Assembly of Subassemblies.....	307-01B-248	Pinpoint Tests.....	308-07A-12
Torque Converter Cleaning And Inspection, Disassembly and Assembly of Subassemblies.....	307-01A-278	Transfer Case — Mechanical Shift On The Fly (MSOF) Operation.....	308-07A-3
Torque Converter Cleaning And Inspection, Disassembly and Assembly of Subassemblies.....	307-01B-248	Transfer Case — MSOF.....	308-07A-103
Torque Converter Diagnosis.....	307-01B-36	Inspection and Verification.....	308-07A-104
Torque Converter End Play Check, Disassembly and Assembly of Subassemblies.....	307-01A-283	Pinpoint Tests.....	308-07A-108
Torque Converter End Play Check, Disassembly and Assembly of Subassemblies.....	307-01B-253	Symptom Chart.....	308-07A-108
Torque Converter Flushing, Disassembly and Assembly of Subassemblies.....	307-01A-280	Transfer Case — Power Flow.....	308-07A-2
Torque Converter Flushing, Disassembly and Assembly of Subassemblies.....	307-01B-250	Transfer Case Draining and Filling.....	308-07B-4
Torque Converter Impeller to Pump Stator Interference Check, Disassembly and Assembly of Subassemblies.....	307-01A-282	Transmission, Assembly.....	307-01A-287
Torque Converter Impeller to Pump Stator Interference Check, Disassembly and Assembly of Subassemblies.....	307-01B-252	Transmission, Assembly.....	307-01B-256
Torque Converter Leak Check, Disassembly and Assembly of Subassemblies.....	307-01A-280	Transmission, Assembly.....	308-03-46
Torque Converter Leak Check, Disassembly and Assembly of Subassemblies.....	307-01B-250	Transmission, Disassembly.....	307-01A-191
Torque Converter One-Way Clutch Check, Disassembly and Assembly of Subassemblies.....	307-01A-284	Transmission, Disassembly.....	307-01B-188
Torque Converter One-Way Clutch Check, Disassembly and Assembly of Subassemblies.....	307-01B-254	Transmission, Disassembly.....	308-03-21
Torque Converter Turbine to Pump Stator Interference Check, Disassembly and Assembly of Subassemblies.....	307-01A-285	Transmission, Installation.....	307-01A-318
Torque Converter Turbine to Pump Stator Interference Check, Disassembly and Assembly of Subassemblies.....	307-01B-255	Transmission, Installation.....	307-01B-278
Torque Multiplication Conversion.....	310-00B-32	Transmission, Installation.....	308-03-61
Torsion Bar.....	204-01B-19	Transmission, Removal.....	307-01A-182
Trailer Lamps.....	417-01-49	Transmission, Removal.....	307-01B-178
Inspection and Verification.....	417-01-49	Transmission, Removal.....	308-03-16
Inspection and Verification.....	417-01-49	Transmission Connector Layouts.....	307-01B-54
Inspection and Verification.....	417-01-50	Transmission Control Switch.....	307-05-21
		Transmission Cooling, Description and Operation.....	307-02-2
		Transmission Cooling, Diagnosis and Testing.....	307-02-6
		Inspection and Verification.....	307-02-6
		Symptom Chart.....	307-02-7
		Transmission Description, Description and Operation.....	307-01A-7
		Transmission Description, Description and Operation.....	307-01B-5
		Transmission Drive Cycle Test.....	307-01B-45
		Transmission Electronic Control System, Description and Operation.....	307-01A-29
		Transmission Electronic Control System, Description and Operation.....	307-01B-28
		Digital Transmission Range (TR) Sensor.....	307-01B-29
		Transmission Filler Tube, In-Vehicle Repair.....	307-01A-142



BUY IT NOW!

Click Here To Order



Alphabetical Index

Transmission Filler Tube, In-Vehicle Repair307-01B-143
 Transmission Fluid Cooler307-01B-100
 Transmission Fluid Cooler — Backflushing and
 Cleaning, General Procedures307-01A-131
 Transmission Fluid Cooler — Backflushing and
 Cleaning, General Procedures307-01B-128
 Transmission Fluid Cooler Tubes.....307-02-16
 Transmission Fluid Drain And Refill, General
 Procedures307-01B-129
 Transmission Fluid Drain And Refill, In-Vehicle
 Repair.....307-01A-132
 Transmission Insulator and Retainer, In-Vehicle
 Repair.....307-01A-179
 Transmission Insulator and Retainer, In-Vehicle
 Repair.....307-01B-173
 Transmission Support Crossmember.....307-01B-177
 Trim Panel — Comer, Upper501-05-14
 Trim Panel — Rear Door501-05-3
 Turbine Shaft Speed (TSS) Sensor and Output
 Shaft Speed (OSS) Sensor.....307-01A-155
 Turn Signal and Hazard Lamps417-01-26
 Inspection and Verification.....417-01-26
 Pinpoint Tests417-01-27
 Symptom Chart.....417-01-27

Valve — Seat Runout303-00-43
 Valve — Seat Width.....303-00-42
 Valve — Spring Free Length303-00-40
 Valve — Spring Squareness303-00-41
 Valve — Stem Diameter303-00-38
 Valve — Stem to Valve Guide Clearance.....303-00-38
 Valve Cover LH, In-Vehicle Repair303-01A-32
 Valve Cover LH, In-Vehicle Repair303-01B-76
 Valve Cover RH, In-Vehicle Repair.....303-01A-35
 Valve Cover RH, In-Vehicle Repair.....303-01B-86
 Valve Seals303-01B-139
 Valve Spring303-01A-50
 Valve Spring Strength303-00-41
 Valve Springs303-01B-137
 Valve Tappet.....303-01A-53
 Valve Tappet — Inspection303-00-37
 Vehicle Demagnetizing419-11-12
 Vehicle Speed Control, Description and Operation310-03-2
 Vehicle Speed Control, Diagnosis and Testing310-03-2
 Principles of Operation.....310-03-2
 Inspection and Verification.....310-03-3
 Self-Test Diagnostics310-03-3
 Symptom Chart.....310-03-4
 Pinpoint Tests310-03-6
 Video Cassette Player.....415-07-2
 Video System, Description and Operation415-07-2
 Video System, Diagnosis and Testing.....415-07-2
 Visual Inspection.....307-01B-38
 Voltage Regulator414-02-6

U

Universal Joint Flange — Front.....205-03-13
 Universal Joints205-01-5
 Universal Transmitter, Description and Operation419-02-2
 Universal Transmitter, Diagnosis and Testing419-02-2
 Inspection and Verification.....419-02-2
 Pinpoint Tests419-02-3
 Symptom Chart.....419-02-3
 Upper Intake Manifold.....303-01A-15

V

Vacuum Control Motor — Air Inlet Door412-04-19
 Vacuum Control Motor — Panel/Defrost Door412-04-14
 Vacuum Control Motor — Panel/Floor Door412-04-13
 Vacuum Hose Repair — Mini-Tube412-00-150
 Vacuum Reservoir Tank and Bracket412-04-19
 Valve206-09A-48
 Valve — Seat Inspection303-00-42
 Valve — Spring Installed Length303-00-40
 Valve — Evaporative Emission Canister Purge303-13-41
 Valve — Fuel Vapor Vent.....303-13-42
 Valve — Spring Free Length303-00-39
 Valve — Spring Squareness303-00-40
 Valve — Stem Diameter303-00-39

W

Warning Devices.....413-09-2
 Warning Indicator Bulb413-01A-85
 Washer Pump and Reservoir501-16-64
 Water Pump, Removal and Installation303-03A-33
 Water Pump, Removal and Installation303-03B-15
 Weld Nut Repair — “J” Nut, Restraints Control
 Module (RCM).....501-20B-155
 Weld Nut Repair — Missing Weld Nut, Restraints
 Control Module (RCM).....501-20B-157
 Weld Nut Repair — Stripped Weld Nut,
 Restraints Control Module (RCM).....501-20B-159
 Wheel211-04-36
 Wheel Alignment Angles204-00-3
 Camber204-00-4
 Toe204-00-4
 Ride Height204-00-5
 Wheel Track204-00-5
 Dogtracking204-00-6
 Nibble204-00-6
 Poor Returnability/Sticky Steering204-00-6

100% SATISFACTION GUARANTEED
BUY IT NOW!
 Click Here To Order

PayPal American Express Discover MasterCard VISA

Alphabetical Index

Wheel Alignment Angles (Continued)

Wander	204-00-6
Shimmy	204-00-6
Drift/Pull	204-00-6
Wheel And Tire	204-04-6
Wheel Bearing Check	100-04-99
Wheel Bearing Inspection	204-00-15
Wheel Cylinder, Disassembly and Assembly	206-02-18
Wheel Cylinder, Removal and Installation	206-02-16
Wheel Hub	204-01B-6
Wheel Leaks	204-04-6
Wheel Studs, Removal and Installation	204-01A-5
Wheel Studs, Removal and Installation	204-01B-10
Wheel Studs, Removal and Installation	204-02-5
Wheels And Tires, Description and Operation	204-04-3
Wheels And Tires, Diagnosis and Testing	204-04-3
Inspection and Verification	204-04-3

Wheels And Tires, Diagnosis and Testing (Continued)

Symptom Chart	204-04-4
Component Tests	204-04-5
Window Control Switch	501-11-50
Window Glass — Back	501-11-54
Window Glass — Rear Side	501-11-51
Windshield Glass	501-11-69
Wiper Blade and Pivot Arm Adjustment — Windshield	501-16-58
Wipers And Washers	501-16-2
Wipers And Washers — GEM/CTM	501-16-2
Inspection and Verification	501-16-3
Symptom Chart	501-16-7
Pinpoint Tests	501-16-8
Wiring Harness — Fuel Charging	303-04C-11
Wiring Repair	501-20B-154



BUY IT NOW!

Click Here To Order



Instructions:

- Use only one form for each publication
- Use separate form for each concern
- Do not use this form to order publications
- Mail the completed form to the address on the reverse side **OR**
- FAX the completed form to (313) 565-7022

Date: _____

- Publication:**
- | | |
|--|--|
| <input type="checkbox"/> Passenger Car Workshop Manual | <input type="checkbox"/> Body Repair Manual |
| <input type="checkbox"/> Wiring Diagram/EVTM | <input type="checkbox"/> Truck Workshop Manual |
| <input type="checkbox"/> PC/ED Manual | <input type="checkbox"/> Rotunda Publication |
| <input type="checkbox"/> TSB Article | |

Vehicle Line: _____ Section and Pages: _____ Model Year: _____

Please check the area in which the concern is located in the publication:

- | | | |
|---|--|--|
| <input type="checkbox"/> Schematic(s) | <input type="checkbox"/> Pinpoint Test(s) | <input type="checkbox"/> Diagnostic(s) |
| <input type="checkbox"/> Removal & Installation | <input type="checkbox"/> Special Service Tools/Equipment | <input type="checkbox"/> Vehicle Application |
| <input type="checkbox"/> Disassembly & Assembly | <input type="checkbox"/> Description & Operation | <input type="checkbox"/> Cleaning & Inspection |
| <input type="checkbox"/> Specifications | <input type="checkbox"/> Adjustments | |

Explain your concern below: (Please print)

What do you think is the main cause of your concern?

- | | | |
|--|---|---|
| <input type="checkbox"/> Missing Information | <input type="checkbox"/> Inaccurate Information | <input type="checkbox"/> Incomplete Information |
|--|---|---|

Is the concern:

- | | | |
|------------------------------------|------------------------------------|-------------------------------|
| <input type="checkbox"/> Editorial | <input type="checkbox"/> Technical | <input type="checkbox"/> Both |
|------------------------------------|------------------------------------|-------------------------------|

Please tell us who you are: (Please print)

Your Name: _____

Company Name: _____ P&A Code: _____ Occupation: _____

Street: _____

City: _____ State: _____ Zip/ Postal Code: _____

Phone Number: _____ FAX Number: _____

Email Address: _____

How would you suggest we change the publication?



BUY IT NOW!

Click Here To Order

...ers! You can submit your Service Publication Concern via the web by visiting " and then choose "Service Publication Error Correction System (SPECS)". Also Technician Society (PTS) web site by choosing "Service Publications" and then



DO NOT STAPLE — USE TRANSPARENT TAPE



NO POSTAGE
NECESSARY
IF MAILED
IN THE
UNITED STATES

BUSINESS REPLY MAIL
FIRST CLASS PERMIT NO. 400 DEARBORN, MI



POSTAGE WILL BE PAID BY ADDRESSEE

Technical Service Publications
P.O. Box 2728
Dearborn, MI 48123-9905



BUY IT NOW!
Click Here To Order 



Ford Motor Company

**TECHNICAL
SUPPORT OPERATIONS**
Automotive Consumer Services Group



A promotional banner with a yellow and orange gradient background. On the left is a circular seal with a scalloped edge containing the text "SATISFACTION 100% GUARANTEED". To the right of the seal, the text "BUY IT NOW!" is written in large, bold, black letters with a white outline. Below this, "Click Here To Order" is written in smaller black letters with a white outline, followed by a red arrow pointing to the right. At the bottom of the banner are five payment logos: PayPal, American Express Cards, Discover, MasterCard, and VISA.

LITHO IN U.S.A.
PG-2608

