

Ford Motor Company



2001 Wiring Diagrams Mustang

[Buy Now](#)



DEMO

This DEMO contains only a few pages of the entire manual/product.

Not all Bookmarks work on the Demo, but they do on the full version.

Features:

- Searchable text
- Printable pages
- Bookmarked for easy navigation
- High Resolution images
- Zoom to see exact details
- Money back Guarantee
- Available on USB and eBook download



License #84356800

Copyright © 2024, Forel Publishing Company, LLC, Woodbridge, Virginia

All Rights Reserved. No part of this book may be used or reproduced in any manner whatsoever without written permission of Forel Publishing Company, LLC. For information write to Forel Publishing Company, LLC, Woodbridge, VA 22192

2001 Mustang Wiring Diagrams

EAN: 978-1-60371-436-5

ISBN: 1-60371-436-7

Forel Publishing Company, LLC
Woodbridge, VA 22192
Email: sales@ForelPublishing.com
<https://www.ForelPublishing.com>



License #84356800

This publication contains material that is reproduced and distributed under a license from Ford Motor Company. No further reproduction or distribution of the Ford Motor Company material is allowed without the express written permission of Ford Motor Company.

Note from the Publisher

This product was created from the original Ford Motor Company's publication. Every effort has been made to use the original scanned images, however, due to the condition of the material; some pages have been modified to remove imperfections.

Disclaimer

Although every effort was made to ensure the accuracy of this book, no representations or warranties of any kind are made concerning the accuracy, completeness or suitability of the information, either expressed or implied. As a result, the information contained within this book should be used as general information only. The author and Forel Publishing Company, LLC shall have neither liability nor responsibility to any person or entity with respect to any loss or damage caused, or alleged to be caused, directly or indirectly by the information contained in this book. Further, the publisher and author are not engaged in rendering legal or other professional services. If legal, mechanical, electrical, or other expert assistance is required, the services of a competent professional should be sought.



WIRING DIAGRAMS

FCS-12121-01

FORD CUSTOMER SERVICE DIVISION

Quality is Job 1

Ford Customer Service Division has developed a new format for the 2001 Mustang Wiring Diagrams. Our goal is to provide accurate and timely electrical information.

2001 Wiring Diagrams Features

- Schematic pages now contain **Component Location** references to full-view illustrations and **Component Descriptions** that describe the system function of a component.
- **"COMPONENT TESTING"** procedures (CELL 149) that tell the user how to perform diagnostic tests on various circuits.
- **Connector End Views** are now located at the end of individual cells and are shown for connectors with five or more cavities; a circuit function chart is provided.
- **NOTES, CAUTIONS and WARNINGS** contain important safety information.
- Full view **"COMPONENT LOCATION VIEWS"** (CELL 151) to help locate on-vehicle components.
- Circuit voltages have been added to schematic pages to help simplify troubleshooting. Nonessential troubleshooting hints have been deleted.
- **Cellular Pagination:** A specific section (or cell) in all Wiring Diagrams is numbered by cell and starts with page 1. For example: **"HOW TO USE THIS MANUAL"** is CELL 2 and begins with page 2-1.
- **"IN-LINE CONNECTOR FACES"** (CELL 150) has been added for in-line connectors with six or more terminals, to aid in servicing electrical wiring.
- **"C"** numbers have been assigned for all electrical connectors. **"C"** numbers are listed in the **"LOCATION INDEX"** (CELL 152).
- **"HARNESS CAUSAL PART NUMBERS"** (CELL 153) has been added to aid in identifying warranty concerns.

in a suffix to denote connector "gender" type (F-socket, M-prior blade).

ditions contained in this manual were in effect at the time this manual was
tor Company reserves the right to discontinue models at any time, or change
notice and without incurring any obligation.

ORDERING INFORMATION

To obtain information about ordering additional copies of this publication or to order any other Ford or Lincoln/Mercury publications, call 1-800-782-4356. Available publications include workshop manuals, wiring diagrams, PC/ED Manuals and Owner Guides.

In addition, you can obtain a publications order form by writing to: Ford Publications, care of Helm Inc., P.O. Box 07150, Detroit, MI 48207.

All rights reserved. Reproduction by any means, electronic or mechanical, including photocopying, recording, or by any information storage and retrieval system or translation in whole or part is not permitted without written authorization from Ford Motor Company.

Copyright © 2000, Ford Motor Company



1-1 TABLE OF CONTENTS/INDEX

2001 MUSTANG

Table of Contents

How to Use This Manual	2-1
Grounds	10-1
Fuse Panel/Circuit Protection	11-1
Charging System	12-1
Power Distribution	13-1
Multiplex Communication Network ...	14-1
Starting System	20-1
Ignition System	21-1
Electronic Engine Controls (3.8L)	23-1
Electronic Engine Controls (4.6L 2V) .	24-1
Electronic Engine Controls (4.6L 4V) .	25-1
Transmission Controls (4R70W)	29-1
Speed Control	31-1
Cooling Fan	33-1
Shift Lock	37-1
Anti-lock Brake System (ABS)	42-1
Horn/Cigar Lighter	44-1
Air Bag Restraint System	46-1
Air Conditioner/Heater	54-1
Rear Window Defrost	56-1
Multifunction Electronic	
Control Modules	59-1
Instrument Cluster	60-1
Warning Chime	66-1
Instrument Illumination	71-1
Interval Wiper/Washer	81-1
Headlamps	85-1
Fog Lamps	86-1
Courtesy Lamps	89-1
Daytime Running Lamps (DRL)	97-1
Turn Signal/Hazard Lamps	90-1
Lamps	92-1
Lamps	93-1
Lamps	100-1
Lamps	102-1
Lamps	10-1

Remote Keyless Entry	111-1
Anti-Theft	112-1
Luggage Compartment	
Lid Release	113-1
Power Seats	120-1
Power Lumbar Seats	122-1
Power Mirrors	124-1
Radio	130-1
Component Testing	149-1
In-Line Connector Faces	150-1
Component Location Views	151-1
Location Index	152-1
Harness Causal Part Number	153-1
Vehicle Repair Location Codes	160-1

Index

Air Bag Restraint System	46-1
Air Conditioner/Heater	54-1
Anti-Lock Brake System (ABS)	42-1
Anti-Theft	112-1
Battery Junction Box	
ABS 1	13-3
ABS 2	13-3
A/C PRESSURE	13-1
ALT	13-1
CONV TOP	13-3
FAN	13-1
FOG, DRL	13-4
FUEL PUMP	13-1
HD LPS	13-2, 13-13
HORN	13-4
HTD BL	13-1
IGN SW	13-2
I/P	13-4
PARK LAMPS	13-2, 13-13
PCM PWR	13-2
POWER POINT	13-3

POWER SEAT	13-4
POWER WINDOWS	13-4
Central Junction Box	
Fuse 1	13-7
Fuse 4	85-1
Fuse 5	13-6, 13-11
Fuse 6	13-5
Fuse 7	13-7, 13-13
Fuse 10	85-1
Fuse 11	13-6, 13-11
Fuse 13	13-7
Fuse 15	13-8
Fuse 17	13-6, 13-11
Fuse 18	13-5, 13-12
Fuse 19	13-7
Fuse 20	13-5, 13-10
Fuse 21	13-8
Fuse 23	13-6, 13-11
Fuse 24	13-5, 13-12
Fuse 25	13-8
Fuse 26	13-5, 13-10
Fuse 27	13-9
Fuse 28	13-5, 13-12
Fuse 29	13-6, 13-11
Fuse 30	13-5, 13-12
Fuse 31	13-8
Fuse 32	13-5, 13-12
Fuse 33	13-9
Fuse 34	13-5, 13-10
Fuse 35	90-1
Fuse 36	13-5, 13-12
Fuse 37	13-13
Fuse 38	85-1
Fuse 39	13-9
Fuse 41	90-1
Charging System	12-1
Cigar Lighter	44-2

100% SATISFACTION GUARANTEED

BUY IT NOW!

Click Here To Order

PayPal American Express Discover MasterCard VISA

TABLE OF CONTENTS/INDEX 1-2

2001 MUSTANG

Component Location Views	151-1	G103	10-3	Fog	86-1
Component Testing		G104	10-2	Hazard	90-1
Driver Seat Control Switch	149-10	G105	10-2	Headlamps	85-1
Exterior Rear View Mirror	149-11	G201	10-4	License	92-1
Ignition Switch	149-2	G203	10-5	Park	
Introduction	149-1	G204	10-6	Front	92-1
Main Light Switch	149-1	G205	10-5	Rear	92-1
Master Window/Door Lock		G300	10-9	Reversing	93-1
Control Switch	149-5, 149-6, 149-7, 149-8	G400	10-7	Side	
Micro ISO Relay	149-13	G402	56-1	Front	92-1
Mini ISO Relay	149-12	Harness Causal Part Numbers	153-1	Rear	92-1
Multifunction Switch	149-3, 149-4	Headlamps	85-1	Stop	90-3
Right Window/Door Lock		Horn	44-1	Turn	
Control Switch	149-9	Ignition Switch	13-5, 13-6	Front	90-2
Convertible Top	102-1	Ignition System	21-1	Rear	90-3
Courtesy Lamps	89-1	Indicators		Lamps (Interior)	
Daytime Running Lamps (DRL)	97-1	Air Bag	60-2	Courtesy	89-1
Defrost (Rear Window)	56-1	Anti-Lock	60-1	Instrument Illumination	71-1
Door Locks (Power)	110-1	Anti-Theft	60-2	Interior	89-2, 89-3
Electronic Engine Control (3.8L)	23-1	Brake	60-2	Luggage Compartment	89-4
Electronic Engine Control (4.6L 2V)	24-1	Charge	60-2	Map	89-2, 89-3
Electronic Engine Control (4.6L 4V)	25-1	Fasten Belts	60-2	Vanity Mirror	89-2, 89-3
Exterior Lamps	92-1	High Beam	60-2	Location Index	152-1
Fog Lamps	86-1	Left Turn	60-2	Luggage Compartment Lid Release ...	113-1
Fuse Panel/Circuit Protection	11-1	Low Coolant	60-2	Main Light Switch	13-13
Gauges		Malfunction Indicator Lamp (MIL)		Mirrors (Power)	124-1
Fuel	60-1	(Check Engine)	60-2	Multiplex Communication Network	14-1
Oil Pressure	60-1	Right Turn	60-2	Power Distribution	13-1
Speedometer	60-2	Transmission Control Indicator		Power Door Locks	110-1
Tachometer	60-2	Lamp (TCIL) (OD OFF)	60-2	Power Lumbar Seat	122-1
Temperature	60-2	In-Line Connector Faces	150-1	Power Mirrors	124-1
Water Temperature	60-2	Instrument Cluster	60-1	Power Windows	100-1
Wiper/Washer	59-1	Instrument Illumination	71-1	Convertible	100-1
Wiper/Washer Control	59-1	Interval Wiper/Washer	81-1	Coupe	100-3
Wiper/Washer Control Switch	59-1	Lamps (Exterior)		Radio	
Wiper/Washer Control Switch	59-1	Daytime Running	97-1	Premium Sound	130-1
Wiper/Washer Control Switch	59-1	Exterior	92-1	MACH 460	130-3



1-3 TABLE OF CONTENTS/INDEX

2001 MUSTANG

Rear Window Defrost	56-1
Remote/Keyless Entry	111-1
Reversing Lamps	93-1
Seats (Lumbar)	122-1
Shift Lock	37-1
Speed Control	31-1
Starting System	20-1
Turn/Stop/Hazard Lamps	90-1
Vehicle Repair Location Codes	160-1
Warning Chime	66-1
Windows (Power)	100-1
Wiper/Washer (Interval)	81-1

IMPORTANT SAFETY NOTICE

Appropriate service methods and proper repair procedures are essential for the safe, reliable operation of all motor vehicles, as well as the personal safety of the individual doing the work. This Manual provides general directions for accomplishing service and repair work with tested, effective techniques. Following them will help assure reliability.

There are numerous variations in procedures, techniques, tools, and parts for servicing vehicles, as well as in the skill of the individual doing the work. This Manual cannot possibly anticipate all such variations and provide advice or cautions as to each. Accordingly, anyone who departs from the instructions provided in this Manual must first establish that the choice of methods, tools, or parts does not compromise personal safety or the vehicle integrity.



BUY IT NOW!
Click Here To Order 

2-1 HOW TO USE THIS MANUAL

2001 MUSTANG

The purpose of this manual is to show electrical circuits in a clear and simple fashion to make troubleshooting easier. **NOTES, CAUTIONS** and **WARNINGS** contain important information.

- **NOTES** describe how switches and other components operate to help complete a particular procedure.
- **CAUTIONS** provide information that could prevent making an error that may damage the vehicle.
- **WARNINGS** provide information to prevent personal injury.

The **WARNINGS** list on page 2-2 contains general warnings to follow when servicing a vehicle.

Components that work together are shown together. All electrical components used in a specific system are shown on one diagram. The circuit breaker or fuse is shown at the top of the page. All wires, connectors, components and splices are shown in the flow of current to ground at the bottom of the page. If a component is used in several different systems, it is shown in several places. For example, the Main Light Switch is electrically a part of many systems and is repeated on many pages.

In some cases, a component may seem (by its name) to belong to a system where it has no electrical connection. For example, Radio Illumination is electrically part of Instrument Illumination, but because it has no electrical connection to the Radio system, it is not shown on the Radio diagram.

Schematic pages contain references to full-view illustrations and description notes for various components. The references are reverse-text blocks on the connector and page and operation

Schematic pages contain circuit voltages to help simplify troubleshooting hints. 12V is used to imply battery voltage on a component connector terminal, and 0V is used to show that there should be continuity to ground on that particular terminal. Conditional voltages such as "12V with the ignition switch in RUN" will also be provided. Troubleshooting hints that can't be simplified with circuit voltages will be shown at the end of each cell.

Component connector face information specific to a certain cell is found at the end of that cell. A Connector Face Reference List is provided to locate connector faces that are shown in different cells. Component connectors with five or more terminals are illustrated and are accompanied by a pinout chart that lists the function of all circuitry associated with that component.

"GROUNDS" (Cell 10) contains ground circuitry shown in complete detail. This information is useful for checking interconnections of the ground circuits of different systems.

"POWER DISTRIBUTION" (Cell 13) contains power distribution circuitry shown in complete detail. This section displays how the various fuses are powered and, in turn, how each system is powered.

"COMPONENT TESTING" (Cell 149) contains testing procedures for various switches. This information includes schematics, component terminal locations and step-by-step procedures.

"IN-LINE CONNECTOR FACES" (Cell 150) contains illustrations of all the in-line connectors that have 6 or more terminals. The terminals have pin numbers assigned to them.

"COMPONENT LOCATION VIEWS" (Cell 151) contains full-view illustrations which show the location of components and connectors in the vehicle.

The **"LOCATION INDEX"** (Cell 152) provides the base part numbers, locations, connector face references and illustration references for all components, connectors, splices and grounds.

HELPFUL REMINDERS

Before using the wiring diagrams for troubleshooting, refer to these HELPFUL REMINDERS:

1. The abbreviation T/O, for take out, used in the Location Index (Cell 152), refers to the point at which a group of wires branch off the harness trunk. Refer to the wiring harness illustration.

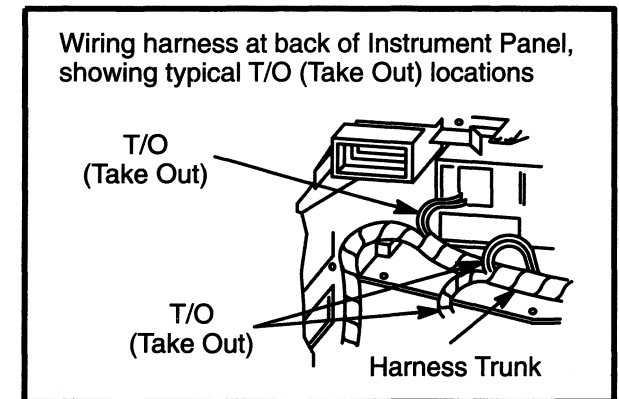

2. If a connector serves the same purpose in two separate versions (e.g., Automatic/Manual), but is physically different, *two* connector numbers are used. However, if a connector serves the same purpose in two separate versions (e.g., Automatic/Manual) and is physically the same, but the wire colors are different, only *one* connector number is used. If the same physical connector is used more than once, then more than *one* connector number is used.

Satisfied 100% Guaranteed

BUY IT NOW!

Click Here To Order

PayPal Discover Cards AMERICAN EXPRESS MasterCard VISA

3. Wiring schematics provide a picture of how and under what conditions the circuit is powered, of the current path to circuit components, and of how a circuit is grounded. Each circuit component is named (underlined titles). Wire and connector colors are listed as follows (standard Ford color abbreviations are used):

COLOR ABBREVIATIONS

BU	Blue	NA	Natural
BK	Black	OG	Orange
BN	Brown	PK	Pink
DB	Dark Blue	VT	Purple
DG	Dark Green	RD	Red
GN	Green	SR	Silver
GY	Gray	TN	Tan
LB	Light Blue	WH	White
LG	Light Green	YE	Yellow

Note: Whenever a wire is labeled with two colors, the first color listed is the basic color of the wire, and the second color listed is the stripe marking of the wire.

4. When reporting Vehicle Repair Location Codes to Ford Customer Service Division, refer to Cell 160 (beginning on page 160-1). Note: Do *not* use the illustrations in Cell 151 (beginning on page 151-1) for reporting Vehicle Repair Location Codes.

5. WARNINGS

- *Always wear safety glasses for eye protection.*
- *Use safety stands whenever a procedure requires being under a vehicle.*
- *Be sure that the **Ignition Switch** is always in the OFF position, unless otherwise required by the procedure.*
- *Set the parking brake when working on any vehicle. An automatic transmission should be in PARK. A manual transmission should be in NEUTRAL.*
- *Operate the engine only in a well-ventilated area to avoid danger of carbon monoxide.*
- *Keep away from moving parts, especially the fan and belts, when the engine is running.*
- *To prevent serious burns, avoid contact with hot metal parts such as the radiator, exhaust manifold, tail pipe, catalytic converter and muffler.*
- *Do not allow flame or sparks near the battery. Gases are always present in and around the battery cell. An explosion could occur.*
- *Do not smoke when working on a vehicle.*
- *To avoid injury, always remove rings, watches, loose hanging jewelry and avoid wearing loose clothing.*

HOW TO FIND ELECTRICAL CONCERNS

TROUBLESHOOTING STEPS

These six steps present an orderly method of troubleshooting.

Step 1. Verify the concern.

- Operate the complete system to check the accuracy and completeness of the customer's complaint.

Step 2. Narrow the concern.

- Using the wiring diagrams, narrow down the possible causes and locations of the concern to pinpoint the exact cause.
- Read the description notes at the components and study the wiring schematic. You should then know enough about the circuit operation to determine where to check for the trouble. Further information can be found by referring to the Service Manual pages listed in the box at the top of the page.

Step 3. Test the suspected cause.

- Use electrical test procedures to find the specific cause of the symptoms.
- The component location reference bars and the pictures will help you find components. The Location Index (at the end of the manual) gives component location information for connectors, diodes, resistors, splices and grounds.

Step 4. Verify the cause.

- Confirm that you have found the correct cause by connecting jumper wires and/or temporarily installing a known good component and operating the circuit.

Step 5. Make the repair.

- Repair or replace the inoperative component.

Step 6. Verify the repair.

- Operate the system as in Step 1 and check that your repair has removed all symptoms without creating any new symptoms.



2-3 HOW TO USE THIS MANUAL

2001 MUSTANG

Some engine circuits may need special test equipment and special procedures. See the *Workshop Manual* and other service books for details. You will find the circuits in this manual to be helpful with those special test procedures.

TROUBLESHOOTING TOOLS

JUMPER WIRE

This is a test lead used to connect two points of a circuit. A Jumper Wire can bypass an open to complete a circuit.

WARNING

Never use a jumper wire across loads (motors, etc.) connected between hot and ground. This direct battery short may cause injury or fire.

VOLTMETER

A DC Voltmeter measures circuit voltage. Connect negative (- or black) lead to ground, and positive (+ or red) lead to voltage measuring point.

OHMMETER

An Ohmmeter shows the resistance between two connected points (Figure 1).

TEST LAMP

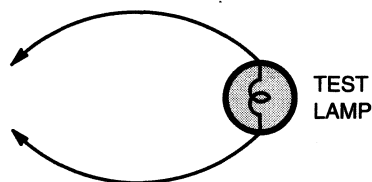

Figure 2 – Test Lamp

A Test Light is a 12-volt bulb with two test leads (Figure 2).

Uses: Voltage Check, Short Check.

SELF-POWERED TEST LAMP

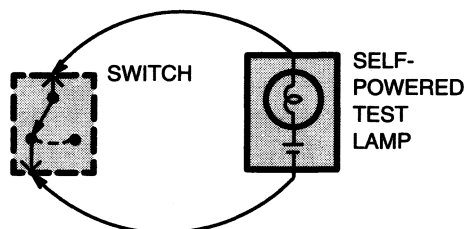

Figure 3 – Continuity Check

The Self-Powered Test Lamp is a bulb, battery and set of test leads wired in series (Figure 3). When connected to two points of a continuous circuit, the bulb glows.

Uses: Continuity Check, Ground Check.

CAUTION

When using a self-powered test lamp or ohmmeter, be sure power is off in circuit during testing. Hot circuits can cause equipment damage and false readings.

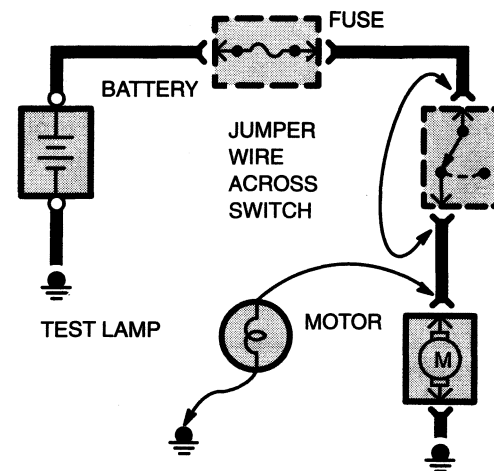

Figure 4 – Switch Circuit Check and Voltage Check

In an inoperative circuit with a switch in series with the load, jumper the terminals of the switch to power the load. If jumpering the terminals powers the circuit, the switch is inoperative (Figure 4).

CONTINUITY CHECK (Locating open circuits)

Connect one lead of Self-Powered Test Lamp or Ohmmeter to each end of circuit (Figure 3). Lamp will glow if circuit is closed. Switches and fuses can be checked in the same way.



100% SATISFACTION GUARANTEED

BUY IT NOW!

Click Here To Order

PayPal, American Express, Discover, MasterCard, VISA

VOLTAGE CHECK

Connect one lead of test lamp to a known good ground or the negative (-) battery terminal. Test for voltage by touching the other lead to the test point. Bulb goes on when the test point has voltage (Figure 4).

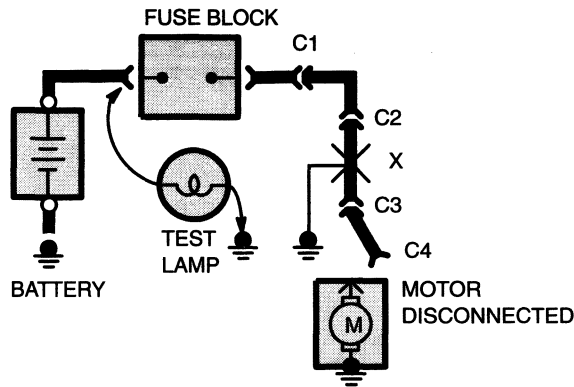

Figure 5 – Short Check

A fuse that repeatedly blows is usually caused by a short to ground. It's important to be able to locate such a short quickly (Figure 5).

1. Turn off everything powered through the fuse.
2. Disconnect other loads powered through the fuse:
 - Motors: disconnect motor connector (Connector C4 in Figure 5).
 - Lights: remove bulbs.

Turn Ignition Switch to RUN (if necessary) to

4. Connect one Test Lamp lead to hot end of blown fuse. Connect other lead to ground. Bulb should glow, showing power to fuse. *(This step is just a check to be sure you have power to the circuit.)*
5. Disconnect the test lamp lead that is connected to ground, and reconnect it to the load side of the fuse at the connector of the disconnected component. (In Figure 5, connect the test lamp lead to connector C4.)
 - If the Test Lamp is off, the short is in the disconnected component.
 - If the Test Lamp goes on, the short is in the wiring. You must find the short by disconnecting the circuit connectors, one at a time, until the Test Lamp goes out. For example, in Figure 5 with a ground at X, the bulb goes out when C1 or C2 is disconnected, but not after disconnecting C3. This means the short is between C2 and C3.

Turn on power to the circuit. Perform a Voltage Check between the suspected inoperative ground and the frame. Any indicated voltage means that the ground is inoperative (Figure 6).

Turn off power to the circuit. Connect one lead of a Self-Powered Test Lamp or Ohmmeter to the wire in question and the other lead to a known ground. If the bulb glows, the circuit ground is OK (Figure 6).

The circuit schematics in this manual make it easy to identify common points in circuits. This knowledge can help narrow the concern to a specific area. For example, if several circuits fail at the same time, check for a common power or ground connection (see *Power Distribution* or *Grounds*). If part of a circuit fails, check the connections between the part that works and the part that doesn't work.

For example, if the low beam headlights work, but the high beams and the indicator lamp don't work, then power and ground paths must be good. Since the dimmer switch is the component that switches this power to the high beam lights and indicator, it is most likely the cause of failure.

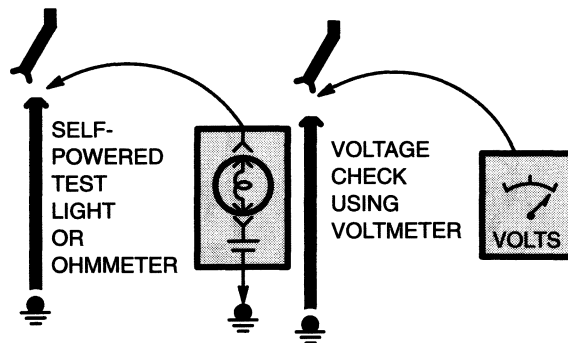

Figure 6 – Ground Check

100% SATISFACTION GUARANTEED

BUY IT NOW!

Click Here To Order

2-5 HOW TO USE THIS MANUAL

2001 MUSTANG

TROUBLESHOOTING WIRING HARNESS AND CONNECTOR HIDDEN CONCERNS

The following illustrations are known examples of wiring harness, splices and connectors that will create intermittent electrical concerns. The concerns are hidden and can only be discovered by a physical evaluation as shown in each illustration.

NOTE: Several components, such as the PCM, utilize gold plated terminals in their connections to the wiring harness. If those terminals need to be replaced, they must be replaced with a gold plated terminal.

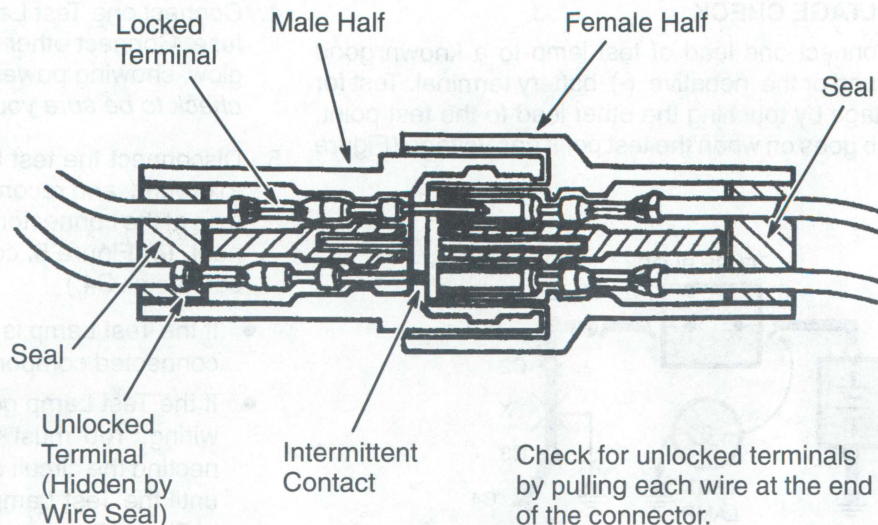

TERMINAL NOT PROPERLY SEATED

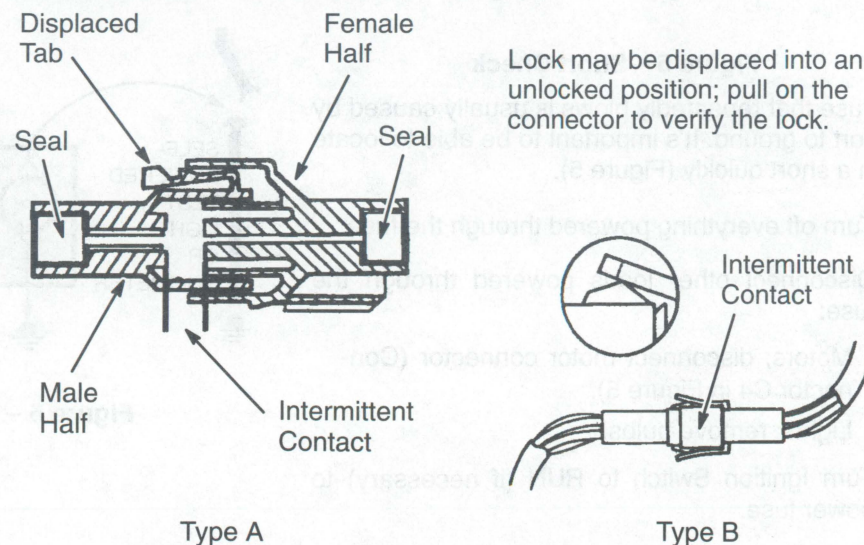
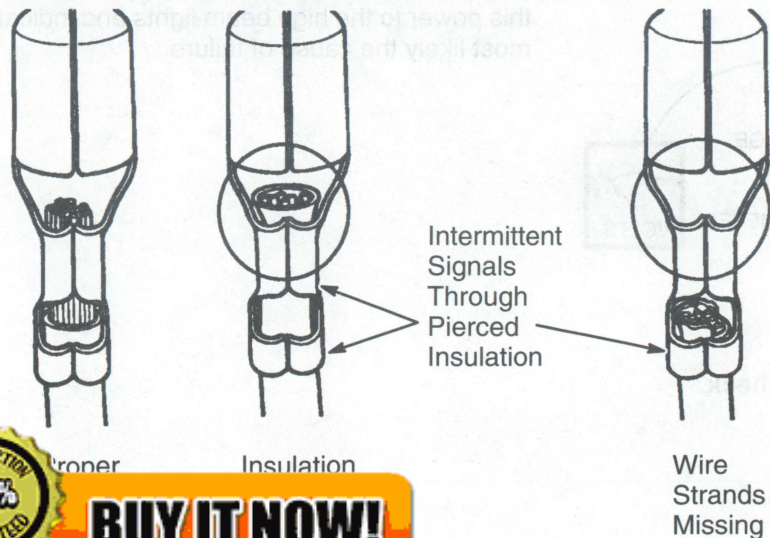

PARTIALLY MATED CONNECTORS

100% SATISFACTION GUARANTEED

BUY IT NOW!

Click Here To Order

PayPal, American Express, Discover, MasterCard, VISA

WIRE STRIPPING

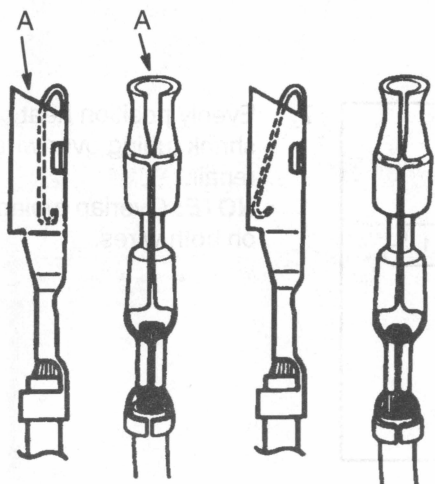

Enlarged

Normal

Any probe entering the terminal may enlarge the contact spring opening creating an intermittent signal. Insert the correct mating terminal (Location A) from the service kit and feel for a loose fit.

DEFORMED (ENLARGED) FEMALE TERMINALS

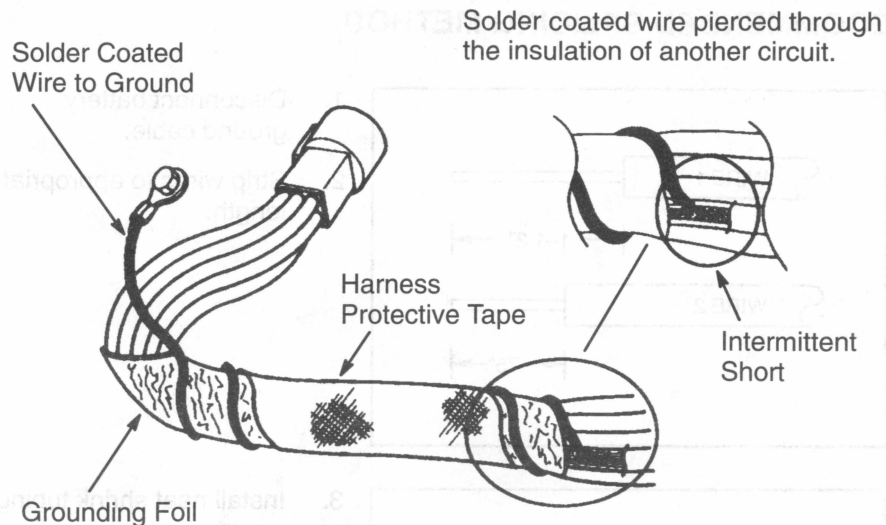

ELECTRICAL SHORT INSIDE THE HARNESS

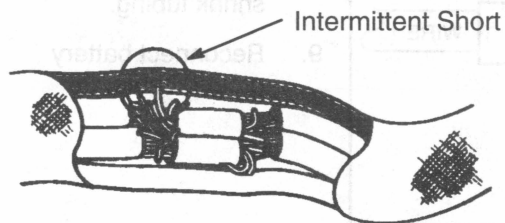

Splice Tape Removed

Intermittent Short

Operate the system and flex the harness at splice location noted in Section 152.

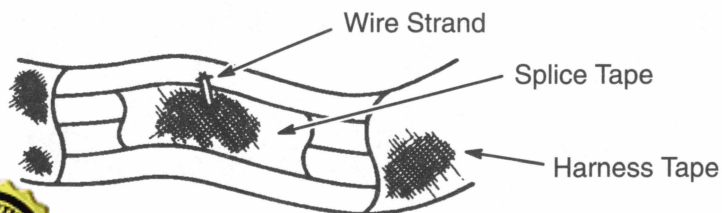

Wire Strand

Splice Tape

Harness Tape

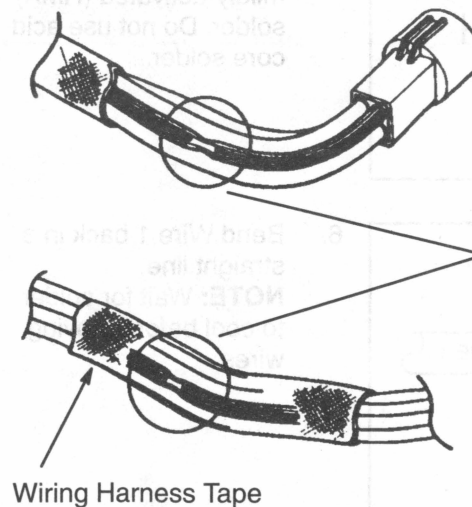

Wiring Harness Tape

Circuit Insulation

Wiring Strand

Broken Strands Intermittent Signal

Remove the tape and flex/feel each circuit for a reduction in diameter at break.

BROKEN WIRE STRANDS IN HARNESS

100% SATISFACTION GUARANTEED

BUY IT NOW!

Click Here To Order

WITHIN THE HARNESS

2-7 HOW TO USE THIS MANUAL

2001 MUSTANG

RECOMMENDED SPLICING METHOD:

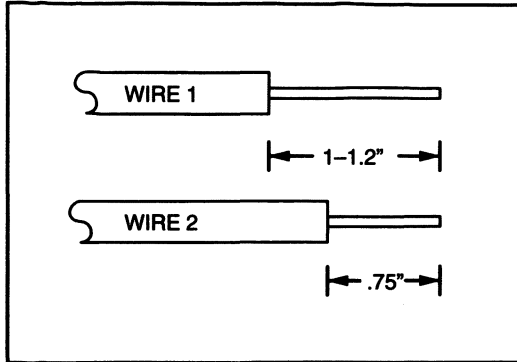

1. Disconnect battery ground cable.
2. Strip wires to appropriate length.

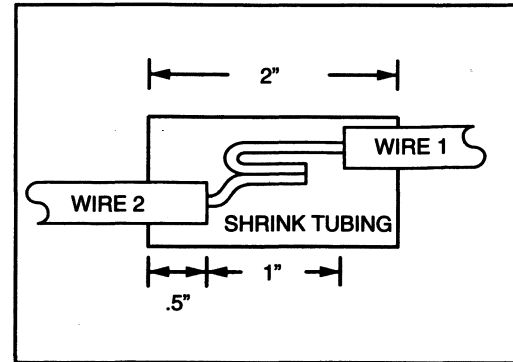

7. Evenly position heat shrink tubing over wire repair.
NOTE: Overlap tubing on both wires.

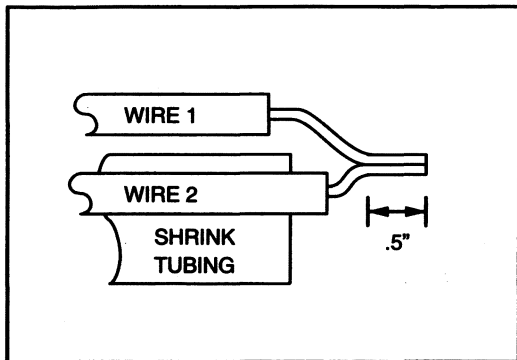

3. Install heat shrink tubing.
4. Twist wires together.
5. Solder wires together.
NOTE: Use rosin core mildly-activated (RMA) solder. Do not use acid core solder.

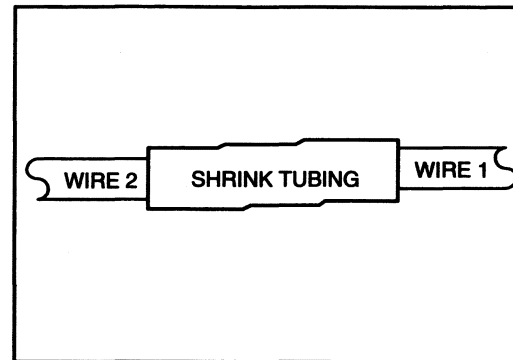

8. Use heat gun to heat the repaired area until adhesive flows out of both ends of heat shrink tubing.
9. Reconnect battery ground cable.



6. Bend Wire 1 back in a straight line.
NOTE: Wait for solder to cool before moving wires.

100% SATISFACTORY GUARANTEED

BUY IT NOW!

Click Here To Order

PayPal, American Express, Discover, MasterCard, VISA

ELECTRICAL SYMBOLS

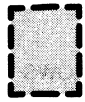

DASHED COMPONENT BOX ONLY PART OF THE COMPONENT IS SHOWN ON THE PAGE; THE COMPONENT IS SHOWN COMPLETE IN ANOTHER LOCATION

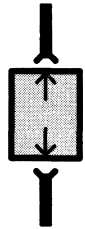

COMPONENT WITH CONNECTORS

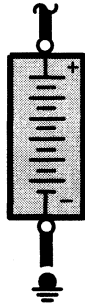

BATTERY

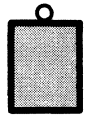

SCREW TERMINAL ON COMPONENT

SOLID STATE

SEALED ELECTRONIC COMPONENT ANY CIRCUITRY SHOWN INSIDE THE BOX IS A FUNCTIONAL

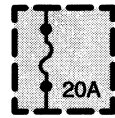

FUSE
CURRENT RATING

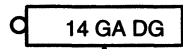

FUSIBLE LINK
WIRE SIZE AND COLOR

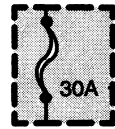

MAXI-FUSE or FUSIBLE LINK CARTRIDGE
CURRENT RATING

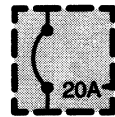

CIRCUIT BREAKER
CURRENT RATING

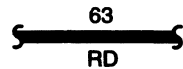

SOLID WIRES

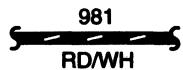

STRIPED WIRES

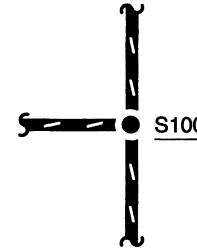

SPLICE OR CRIMP TERMINAL

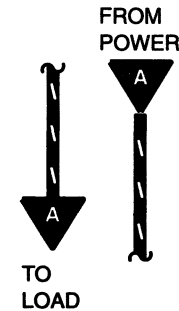

"CUT" WIRES REFERENCED BETWEEN PAGES ARROWS SHOW CURRENT FLOW FROM POWER TO GROUND



REVERSING LAMPS

"REFERENCE" WIRES COMPLETE WIRING SHOWN ON ANOTHER PAGE

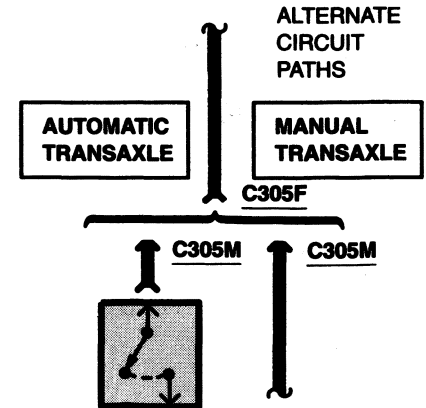

100% SATISFACTION GUARANTEED

BUY IT NOW!

Click Here To Order

2-9 HOW TO USE THIS MANUAL

2001 MUSTANG

ELECTRICAL SYMBOLS

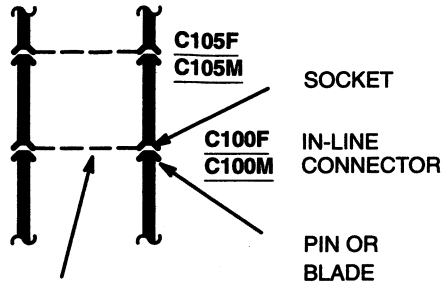

SINGLE DASHED LINE INDICATES THAT WIRE ON LEFT ALSO PASSES THROUGH THE SAME CONNECTOR

SEE GROUNDS
PAGES 10-1,
10-2

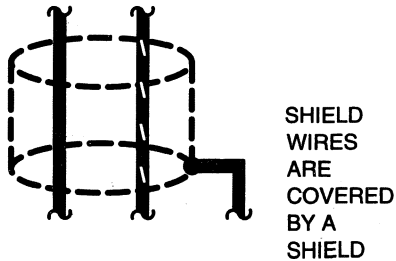
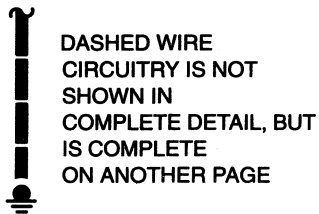

MOTOR



HEATING ELEMENT



THERMISTOR



RHEOSTAT OR POTENTIOMETER



SOLENOID

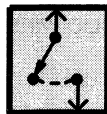

SWITCH



GANGED SWITCHES CONTACTS MOVE AT THE SAME TIME



DIODES CURRENT FLOWS IN DIRECTION OF ARROW ONLY

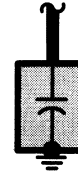

CAPACITOR



TRANSISTOR



GAUGE



LIGHT EMITTING DIODE (LED)



LIGHT BULB



DUAL FILAMENT LIGHT BULB

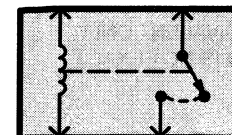

RELAY CONTACTS CHANGE POSITION WITH CURRENT THROUGH COIL

SATISFACTORY 100% GUARANTEED

BUY IT NOW!

Click Here To Order

HOW TO USE THIS MANUAL 2-10

2001 MUSTANG

100% SATISFACTION GUARANTEED

BUY IT NOW!

Click Here To Order

PayPal American Express Discover MasterCard VISA

10-1 GROUNDS

2001 MUSTANG

All wires are
1205 (BK)
unless other-
wise noted.

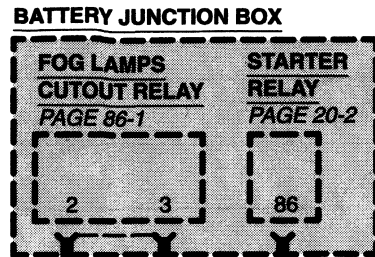

**LEFT
FOG
LAMP**
PAGE 86-1



C124

**LEFT FRONT
PARK/TURN
LAMP**
PAGES 90-2,
92-1



C122

**LEFT
HEADLAMP**
PAGES 85-1,
97-2

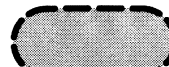

C120

**WINDSHIELD
WASHER
PUMP
MOTOR**
PAGE 81-1



C126

**SPEED
CONTROL
SERVO**
PAGE 31-1



C136

**DAYTIME
RUNNING
LAMPS (DRL)
MODULE**
PAGE 97-1



C170

**ANTI-LOCK
BRAKE
CONTROL
MODULE**
PAGE 42-1



C141

151-2 F9

G102

**SATISFACTORY
100%
GUARANTEED**

BUY IT NOW!

Click Here To Order

PayPal
Credit Cards
DISCOVER
MasterCard
VISA

10-3 GROUNDS

2001 MUSTANG

All wires are 1205 (BK)
unless otherwise noted.

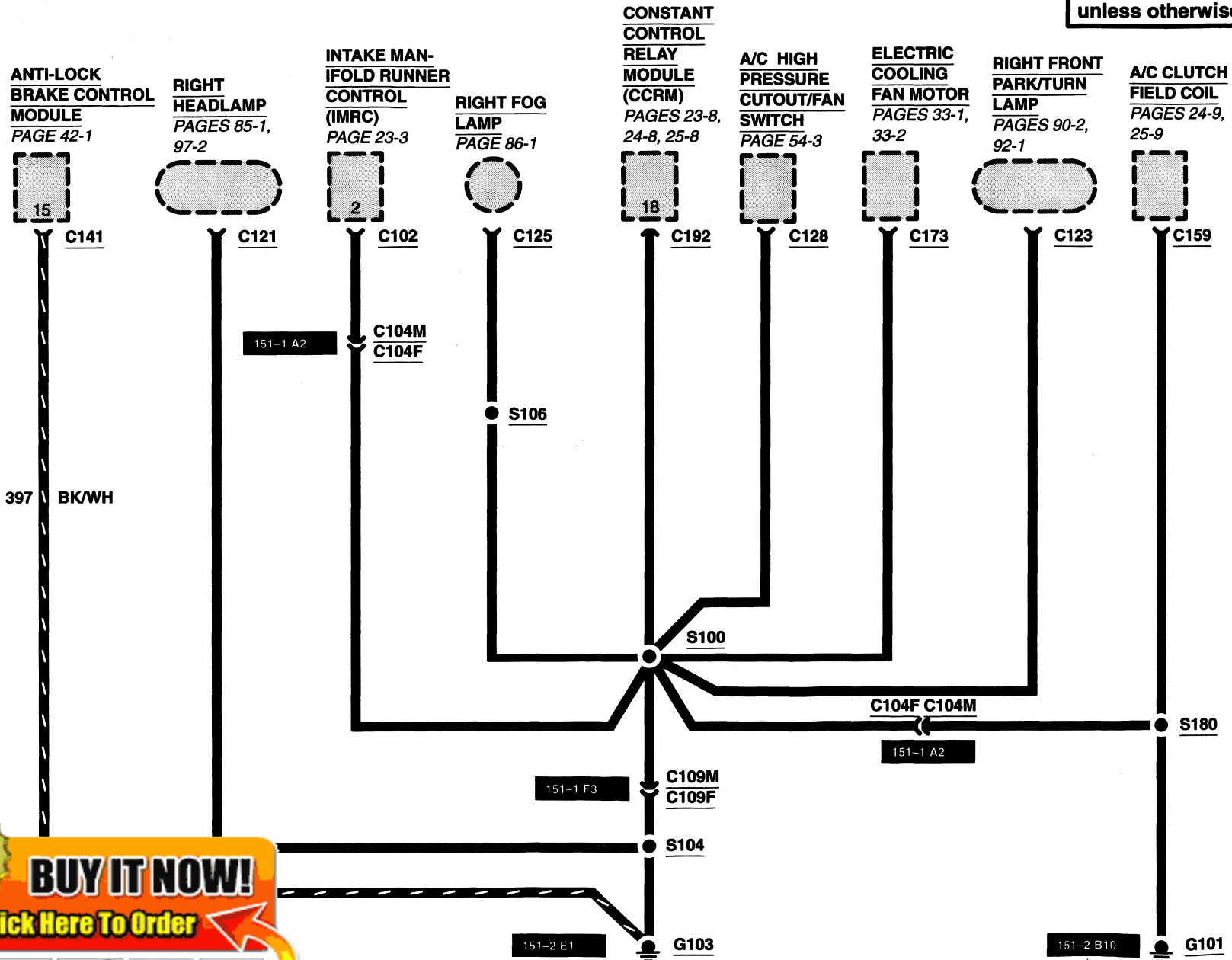

100% SATISFACTION GUARANTEED

BUY IT NOW!

Click Here To Order

PayPal
Discover
MasterCard
VISA

All wires are 1205 (BK) unless otherwise noted.

POWERTRAIN CONTROL MODULE (PCM)
PAGES 23-1, 24-1, 25-1

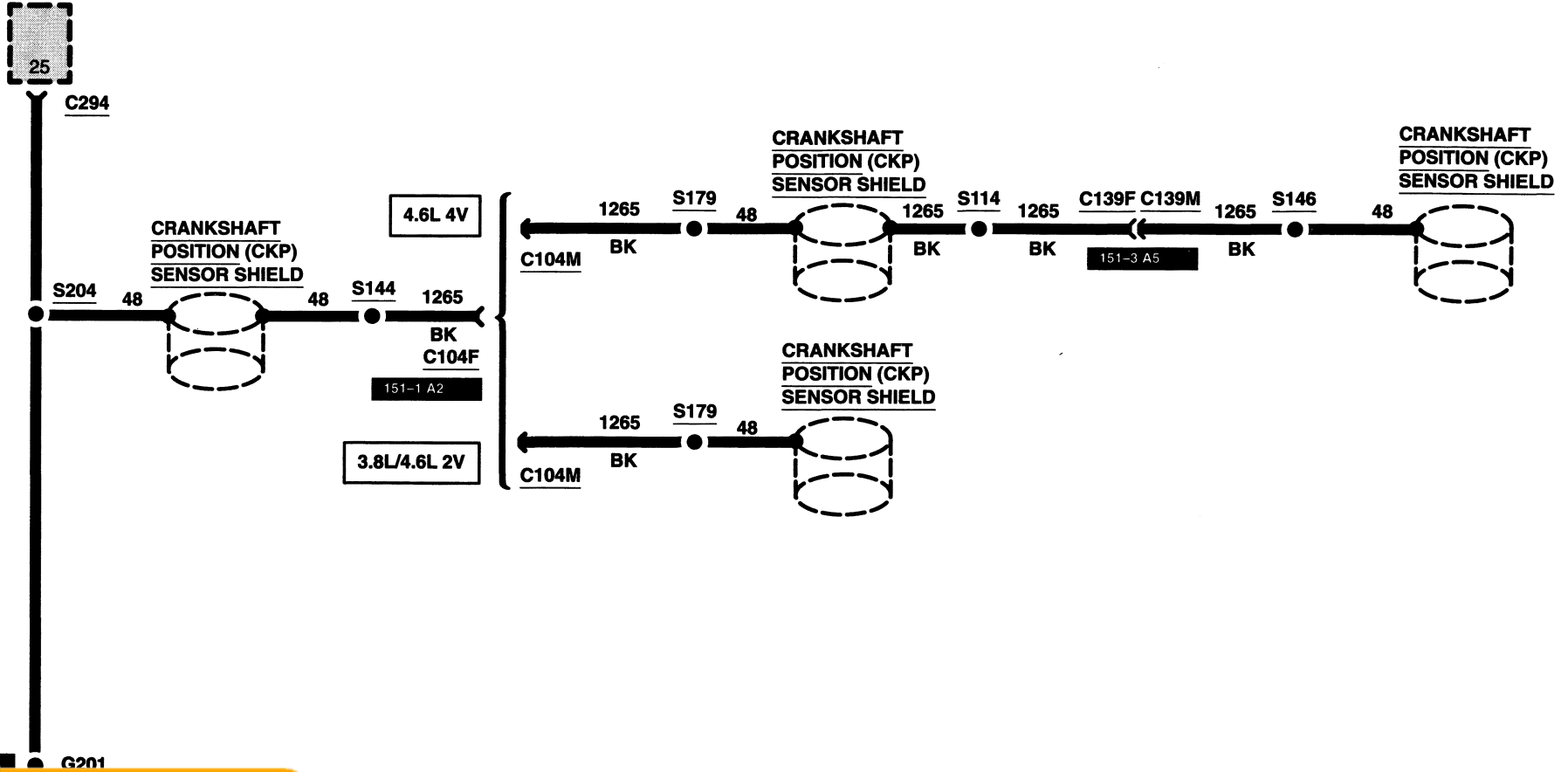

100% SATISFACTION GUARANTEED

BUY IT NOW!

Click Here To Order

10-5 GROUNDS

2001 MUSTANG

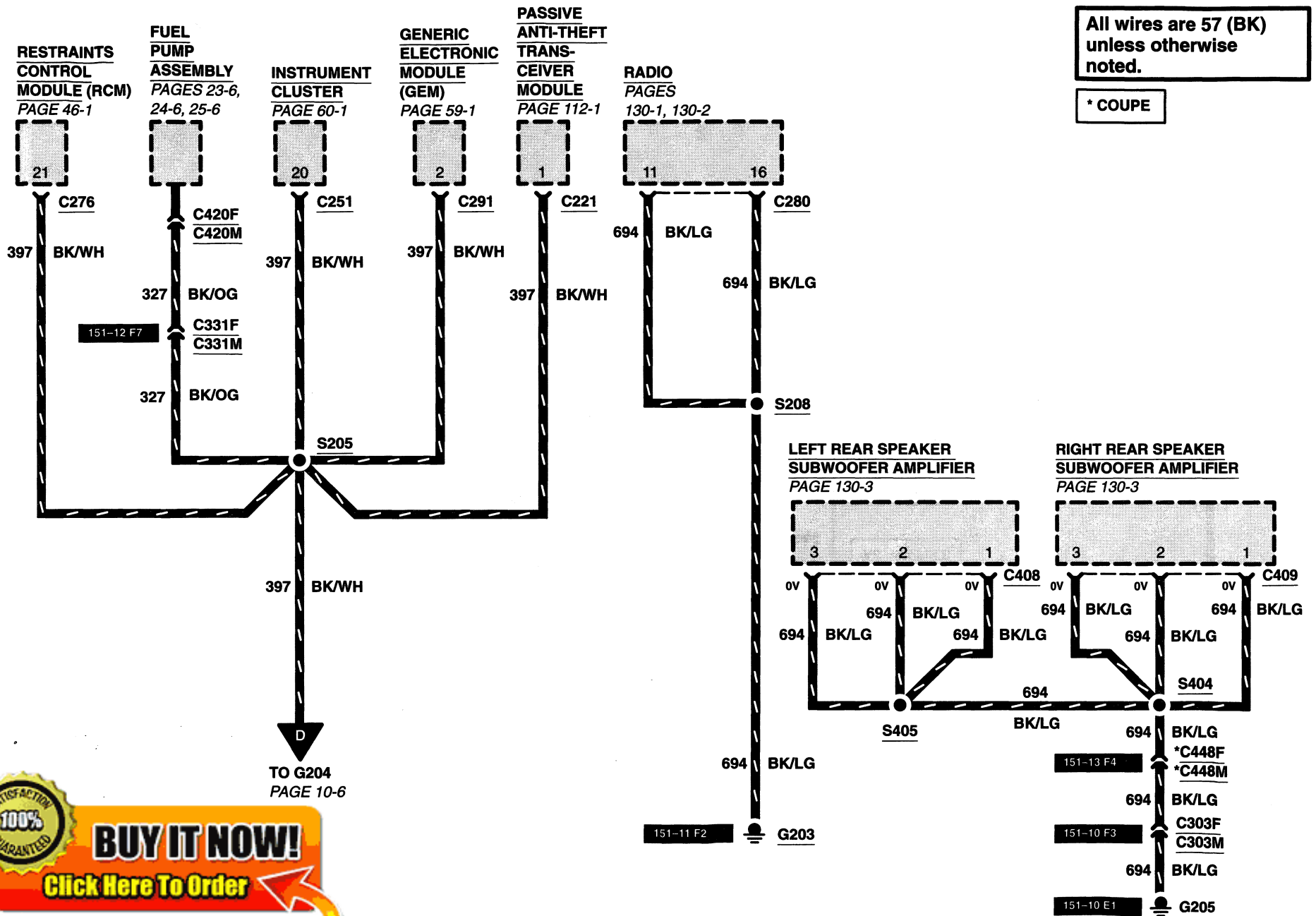

100% SATISFACTION GUARANTEED

BUY IT NOW!

Click Here To Order

All wires are 1205 (BK) unless otherwise noted.

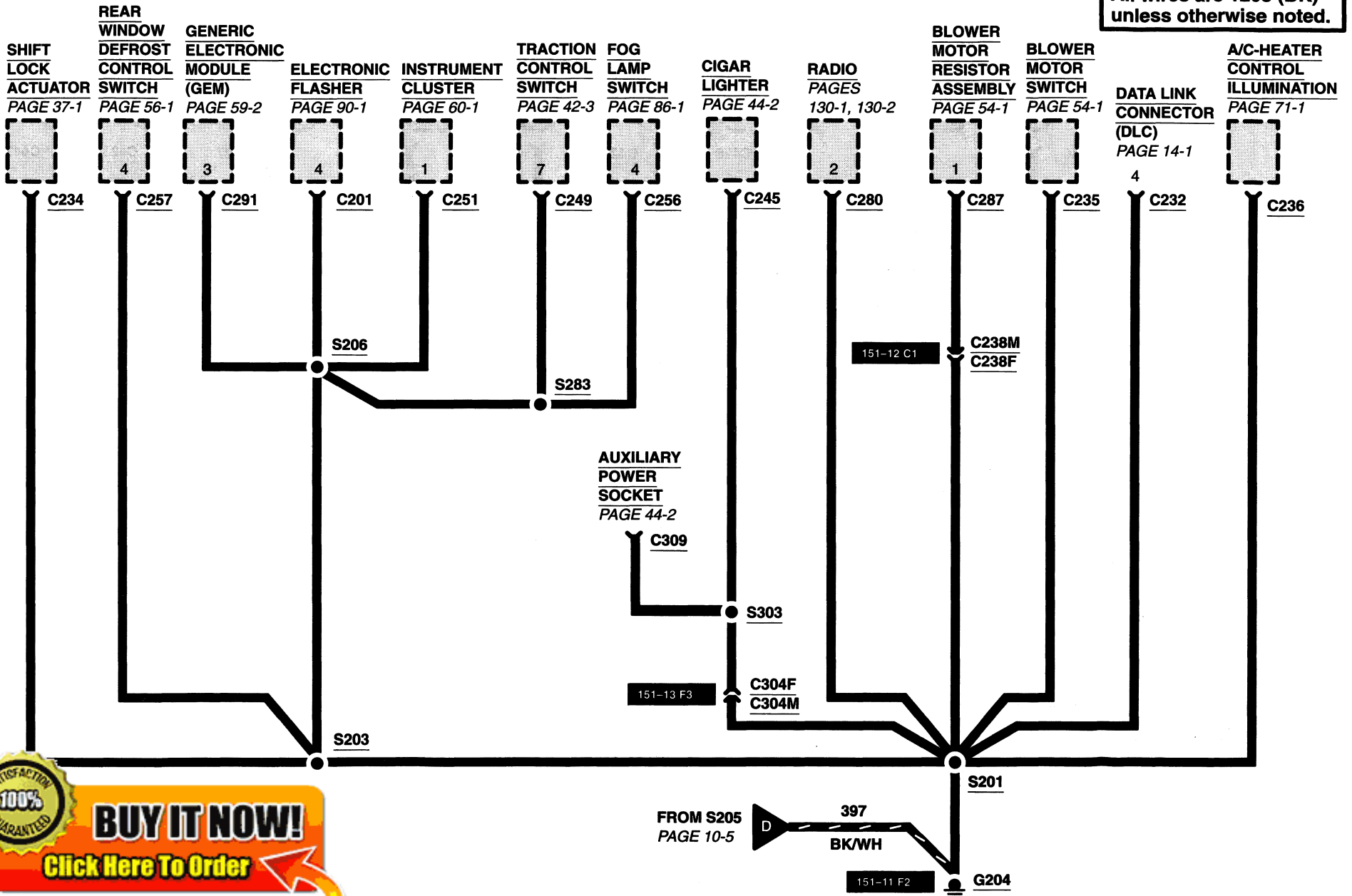

100% SATISFACTION GUARANTEED

BUY IT NOW!

Click Here To Order

PayPal, Discover, MasterCard, VISA

10-7 GROUNDS

2001 MUSTANG

* COBRA

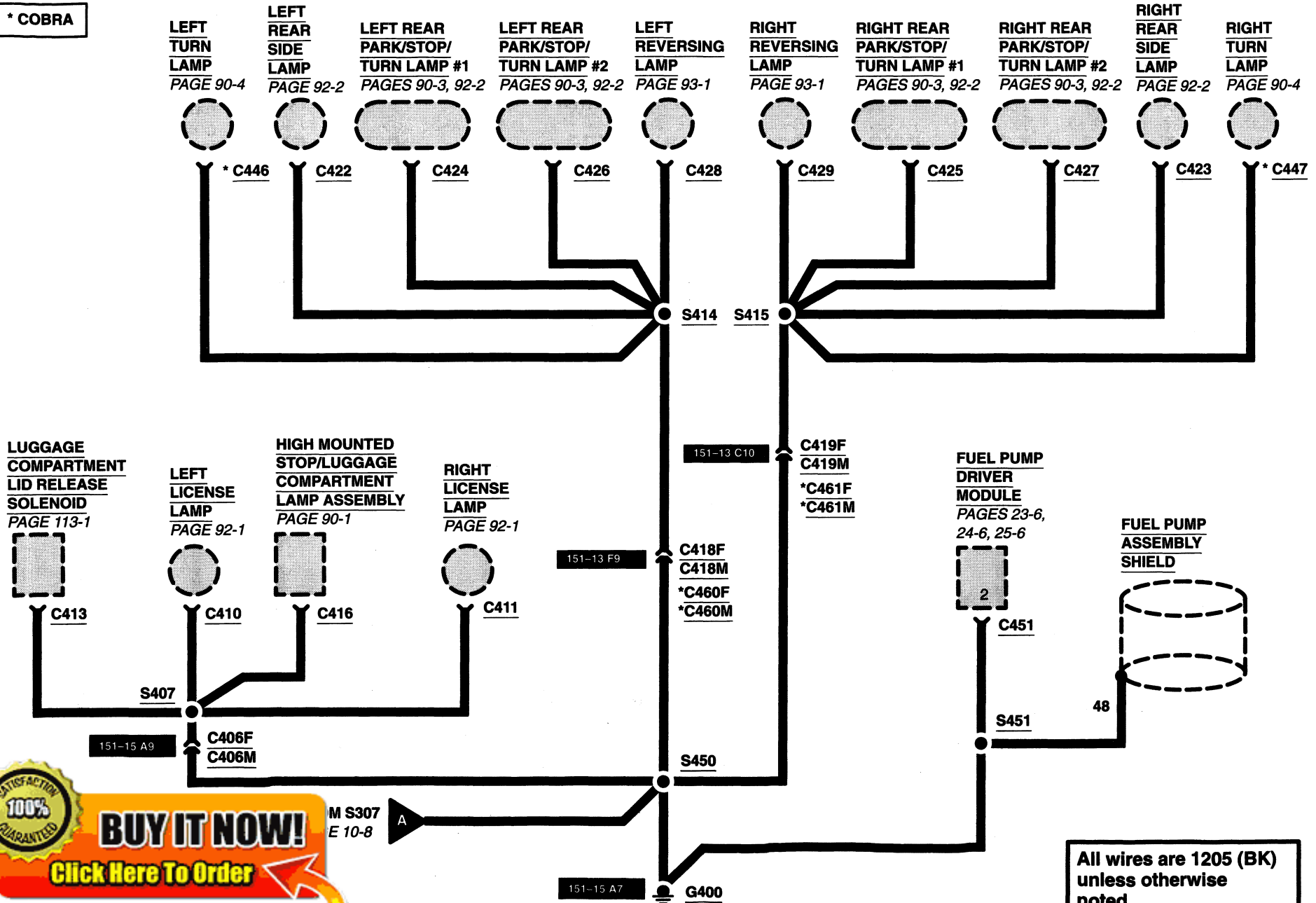

All wires are 1205 (BK) unless otherwise noted.

100% SATISFACTION GUARANTEED

BUY IT NOW!

Click Here To Order

PayPal | American Express | Discover | MasterCard | VISA

GROUNDS 10-8

2001 MUSTANG

* COUPE
** CONVERTIBLE

All wires are 1205 (BK) unless otherwise noted.

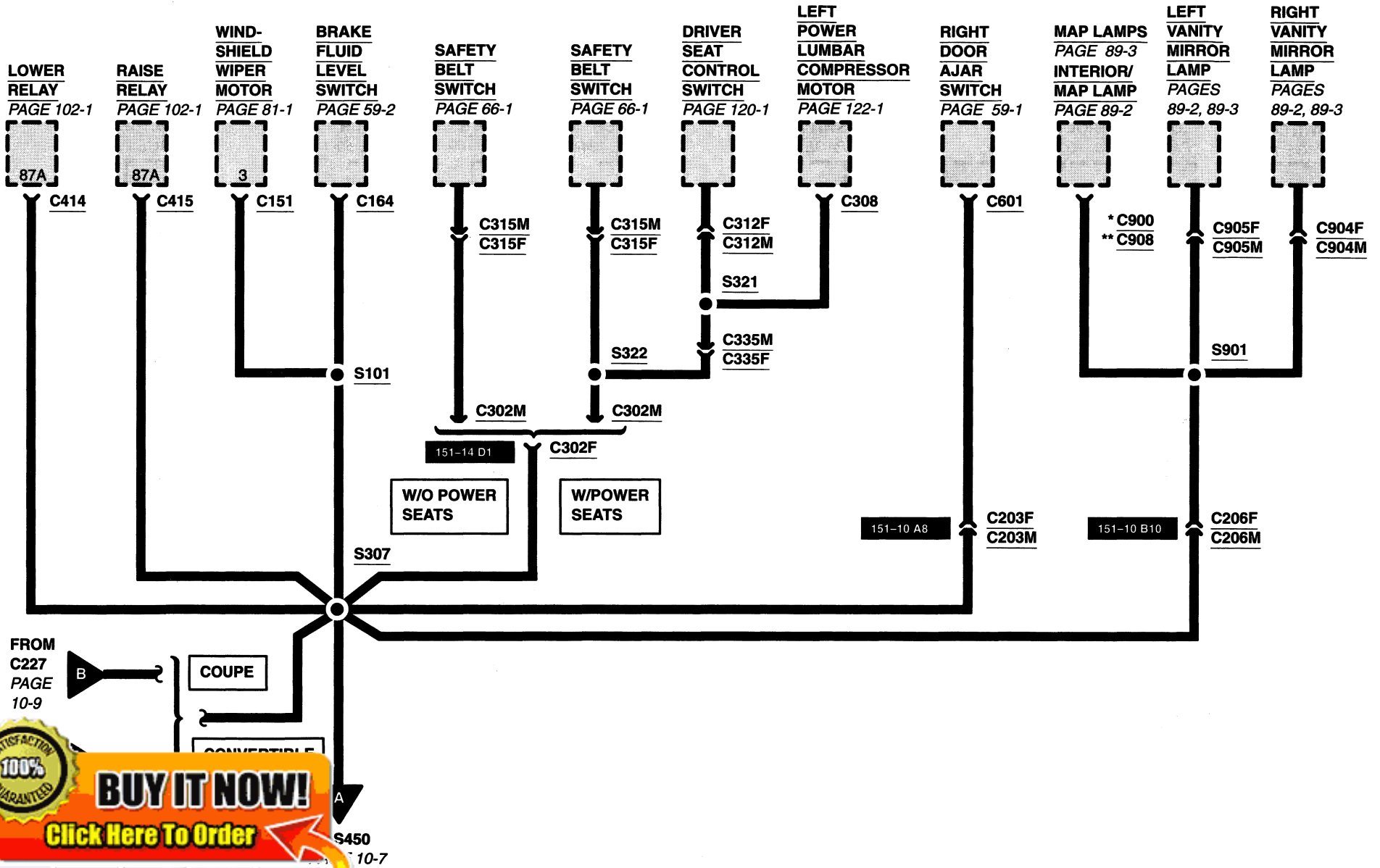

100% SATISFACTION GUARANTEED

BUY IT NOW!

[Click Here To Order](#)

FROM C227 PAGE 10-9

COUPE

CONVERTIBLE

S450 PAGE 10-7

PayPal

Discover

MasterCard

VISA

100% SATISFACTION GUARANTEE
NO QUESTIONS ASKED

BUY IT NOW!

Click Here To Order

PayPal American Express Discover MasterCard VISA

Ford Motor Company

**TECHNICAL
SUPPORT OPERATIONS**
Automotive Consumer Services Group

OCTOBER 2000

LITHO IN U.S.A.
AD-296



FCS-12121-01