

Ford Motor Company

2001 Workshop Manual

DEMO

This DEMO contains only a few pages of the entire manual/product.

Not all Bookmarks work on the Demo, but they do on the full version.

Features:

- Searchable text
- Printable pages
- Bookmarked for easy navigation
- High Resolution images
- Zoom to see exact details
- Money back Guarantee
- Available on USB and eBook download



[Buy Now](#)



F-150

VOLUME 1 and 2



Official
Licensed
Product

184356800



BUY IT NOW!

[Click Here To Order](#)



Copyright © 2025, Forel Publishing Company, LLC, Woodbridge, Virginia

All Rights Reserved. No part of this book may be used or reproduced in any manner whatsoever without written permission of Forel Publishing Company, LLC. For information write to Forel Publishing Company, LLC, Woodbridge, VA 22192

2001 Ford F-150 Truck Workshop Manual (Volume 1 and 2)

EAN: 978-1-60371-487-7

ISBN: 1-60371-487-1

Forel Publishing Company, LLC
Woodbridge, VA 22192
Email: sales@ForelPublishing.com
<https://www.ForelPublishing.com>



License #84356800

This publication contains material that is reproduced and distributed under a license from Ford Motor Company. No further reproduction or distribution of the Ford Motor Company material is allowed without the express written permission of Ford Motor Company.

Note from the Publisher

This product was created from the original Ford Motor Company's publication. Every effort has been made to use the original scanned images, however, due to the condition of the material; some pages have been modified to remove imperfections.

Disclaimer

Although every effort was made to ensure the accuracy of this book, no representations or warranties of any kind are made concerning the accuracy, completeness or suitability of the information, either expressed or implied. As a result, the information contained within this book should be used as general information only. The author and Forel Publishing Company, LLC shall have neither liability nor responsibility to any person or entity with respect to any loss or damage caused, or alleged to be caused, directly or indirectly by the information contained in this book. Further, the publisher and author are not engaged in rendering legal or other professional services. If legal, mechanical, electrical, or other expert assistance is required, the services of a competent professional should be sought.



Ford Motor Company

2001 Workshop Manual



F-150

VOLUME 1



184356800



BUY IT NOW!

Click Here To Order 



2001 F-150

TABLE OF CONTENTS

INTRODUCTION

GENERAL INFORMATION Volume 1

SERVICE INFORMATION

Identification Codes	100-01
Jacking and Lifting	100-02
Noise, Vibration and Harshness	100-04

CHASSIS Volume 1

SUSPENSION

Suspension System — General Information	204-00
Front Suspension — 4x2	204-01A
Front Suspension — 4x4	204-01B
Rear Suspension	204-02
Wheels and Tires	204-04

DRIVELINE

Driveline System — General Information	205-00
Driveshaft	205-01
Rear Drive Axle/Differential —	
Ford 8.8-Inch Ring Gear	205-02A
Rear Drive Axle/Differential —	
Ford 9.75-Inch Ring Gear	205-02B
Rear Drive Axle/Differential —	
Ford 10.25-Inch Ring Gear	205-02C
Front Drive Axle/Differential —	
Ford 8.8-Inch Ring Gear	205-03
Front Drive Halfshafts	205-04

BRAKE SYSTEM

Brake System — General Information	206-00
Drum Brake	206-02
Front Disc Brake	206-03
Rear Disc Brake	206-04
Parking Brake and Actuation	206-05
Hydraulic Brake Actuation	206-06
Power Brake Actuation	206-07
Anti-Lock Control — Rear	206-09A
Anti-Lock Control — 4-Wheel	206-09B

STEERING SYSTEM

Steering System — General Information	211-00
Power Steering	211-02
Steering Linkage	211-03
Steering Column	211-04
Steering Column Switches	211-05

POWERTRAIN..... Volume 2

ENGINE

Engine System — General Information	303-00
Engine — 4.2L	303-01A
Engine — 4.6L and 5.4L	303-01B
Engine Cooling	303-03A
Supercharger Cooling	303-03B
Fuel Charging and Controls — 4.2L	303-04A
Fuel Charging and Controls —	
4.6L (2V) and 5.4L (2V)	303-04B
Fuel Charging and Controls —	
Natural Gas Vehicle	303-04C
Fuel Charging and Controls —	
Bi-Fuel Vehicles	303-04D
Accessory Drive	303-05
Starting System	303-06
Engine Ignition — 4.2L	303-07A
Engine Ignition — 4.6L (2V) and 5.4L (2V)	303-07B
Engine Emission Control	303-08
Intake Air Distribution and Filtering	303-12
Evaporative Emissions	303-13
Electronic Engine Controls	303-14

AUTOMATIC TRANSMISSION

Automatic Transmission — 4R100	307-01A
Automatic Transmission — 4R70W	307-01B
Transaxle/Transmission Cooling	307-02
Automatic Transaxle/Transmission	
External Controls	307-05

NOTE: The descriptions and specifications contained in this manual were in effect at the time this manual was approved for printing. Ford Motor Company reserves the right to discontinue models at any time, or change specifications or design without notice and without incurring any obligation.

PUBLICATIONS ORDERING INFORMATION

To obtain information about ordering additional copies of this publication or to order any other Ford or Lincoln/Mercury publications, call 1-800-782-4356. Available publications include workshop manuals, wiring diagrams, PC/ED Manuals and Owner Guides.

You can obtain a publications order form by writing to: Ford Publications, care of Helm Inc., P.O. Box 07150, Detroit, MI 48207.

Electronic or mechanical, including photocopying, recording, or by any information storage and permitted without written authorization from Ford Motor Company.



BUY IT NOW!

Click Here To Order



2001 F-150

TABLE OF CONTENTS

MANUAL TRANSMISSION, CLUTCH AND TRANSFER CASE

Manual Transaxle/Transmission and Clutch — General Information	308-00
Clutch	308-01
Clutch Controls	308-02
Manual Transaxle/Transmission	308-03
Transfer Case — General Information	308-07A
Transfer Case	308-07B

EXHAUST SYSTEM

Exhaust System — General Information	309-00
--	--------

FUEL SYSTEM

Fuel System — General Information	310-00A
Fuel System — General Information — Natural Gas	310-00B
Fuel System — General Information — Bi-Fuel Vehicles	310-00C
Fuel Tank and Lines	310-01A
Fuel Tank and Lines — Natural Gas	310-01B
Fuel Tank and Lines — Bi-Fuel Vehicles	310-01C
Acceleration Control	310-02
Vehicle Speed Control	310-03

ELECTRICAL..... Volume 1

CLIMATE CONTROL SYSTEM

Climate Control System — General Information.....	412-00
Air Distribution and Filtering	412-01
Heating and Ventilation	412-02
Air Conditioning	412-03
Control Components	412-04

INSTRUMENTATION AND WARNING SYSTEMS

Instrument Cluster and Panel Illumination	413-00
Instrument Cluster — Conventional	413-01A
Instrument Cluster — Natural Gas Vehicle	413-01B
Instrument Cluster — Bi-Fuel Vehicles	413-01C
Horn	413-06
Warning Devices	413-09

BATTERY AND CHARGING SYSTEM

Charging System — General Information	414-00
Battery, Mounting and Cables	414-01
Generator and Regulator	414-02

AUDIO SYSTEMS

Entertainment System — General Information.....	415-00
Audio Unit	415-01
Antenna	415-02
Speakers	415-03
Video System	415-07

LIGHTING

Exterior Lighting	417-01
Interior Lighting	417-02
Daytime Running Lamps	417-04

ELECTRICAL DISTRIBUTION

Module Communications Network	418-00
Module Configuration	418-01

ELECTRONIC FEATURE GROUP

Anti-Theft — PATS	419-01
Remote Convenience	419-02
Multifunction Electronic Control Modules	419-10
Electronic Compass	419-11

BODY AND PAINT..... Volume 1

BODY

Body System — General Information.....	501-00
Front End Body Panels	501-02
Body Closures.....	501-03
Pickup Bed and Platform Body	501-04
Interior Trim and Ornamentation	501-05
Exterior Trim and Ornamentation	501-08
Rear View Mirrors	501-09
Seating.....	501-10
Glass, Frames and Mechanisms.....	501-11
Instrument Panel and Console.....	501-12
Handles, Locks, Latches and Entry Systems	501-14
Wipers and Washers.....	501-16
Roof Opening Panel.....	501-17
Bumpers	501-19
Occupant Restraints — Active	501-20A
Occupant Restraints — Passive — Supplemental Air Bag System	501-20B

FRAME AND MOUNTING

Full Frame and Body Mounting	502-02
------------------------------------	--------

INDEX



INTRODUCTION

NOTE: The descriptions and specifications contained in this manual were in effect at the time this manual was approved for printing. Ford Motor Company reserves the right to discontinue models at any time, or change specifications or design without notice and without incurring any obligation.

IMPORTANT SAFETY NOTICE

Appropriate service methods and procedures are essential for the safe, reliable operation of all motor vehicles as well as the personal safety of the individual doing the work. This manual provides general directions for performing service with tested, effective techniques. Following them will help assure reliability.

There are numerous variations in procedure, techniques, tools and parts for servicing vehicles, as well as in the skill of the individual doing the work. This manual cannot possibly anticipate all such variations and provide advice or cautions as to each. Accordingly, anyone who departs from the instructions provided in this manual must first establish that he comprises neither his personal safety nor the vehicle integrity by his choice of methods, tools or parts.

NOTES, CAUTIONS, AND WARNINGS

As you read through the procedures, you will come across **NOTES**, **CAUTIONS**, and **WARNINGS**. Each one is there for a specific purpose. **NOTES** give you added information that will help you to perform a particular procedure. **CAUTIONS** are given to prevent you from making an error that could damage the vehicle. **WARNINGS** remind you to be especially careful in those areas where carelessness can cause you personal injury. The following list contains some general **WARNINGS** that you should follow when you work on a vehicle.

- **ALWAYS WEAR SAFETY GLASSES FOR EYE PROTECTION.**
- **USE SAFETY STANDS WHENEVER A PROCEDURE REQUIRES YOU TO BE UNDER THE VEHICLE.**
- **MAKE SURE THAT THE IGNITION SWITCH IS ALWAYS IN THE OFF POSITION, UNLESS OTHERWISE REQUIRED BY THE PROCEDURE.**
- **SET THE PARKING BRAKE WHEN WORKING ON THE VEHICLE. IF YOU HAVE AN AUTOMATIC TRANSMISSION, SET IN PARK UNLESS INSTRUCTED OTHERWISE FOR A SPECIFIC OPERATION. IF YOU HAVE A MANUAL TRANSMISSION, IT SHOULD BE IN REVERSE (ENGINE OFF) OR NEUTRAL (ENGINE ON) UNLESS INSTRUCTED OTHERWISE FOR A SPECIFIC OPERATION. PLACE WOOD BLOCKS (4" X 4" OR LARGER) AGAINST THE FRONT AND REAR SURFACES OF THE TIRES TO HELP PREVENT THE VEHICLE FROM MOVING.**
- **OPERATE THE ENGINE ONLY IN A WELL-VENTILATED AREA TO AVOID THE DANGER OF CARBON MONOXIDE POISONING.**
- **KEEP YOURSELF AND YOUR CLOTHING AWAY FROM MOVING PARTS WHEN THE ENGINE IS RUNNING, ESPECIALLY THE DRIVE BELTS.**
- **TO PREVENT SERIOUS BURNS, AVOID CONTACT WITH HOT METAL PARTS SUCH AS THE RADIATOR, EXHAUST MANIFOLD, TAIL PIPE, THREE-WAY CATALYTIC CONVERTER AND MUFFLER.**
- **DO NOT SMOKE WHILE WORKING ON A VEHICLE.**

DO NOT SMOKE WHILE WORKING ON A VEHICLE. ALWAYS REMOVE RINGS, WATCHES, LOOSE HANGING JEWELRY AND LOOSE CLOTHING BEFORE WORKING ON A VEHICLE.

UNDER THE HOOD, KEEP HANDS AND OTHER OBJECTS CLEAR OF



BUY IT NOW!

Click Here To Order



General Information

GROUP

1

SECTION TITLE	PAGE
Identification Codes	100-01-1
Jacking and Lifting	100-02-1
Noise, Vibration and Harshness	100-04-1

SECTION 100-01 Identification Codes

VEHICLE APPLICATION: F150

CONTENTS	PAGE
DESCRIPTION AND OPERATION	
Identification Codes	100-01-2

100% SATISFACTION GUARANTEED

BUY IT NOW!

Click Here To Order

PayPal American Express Cards DISCOVER NOVUS MasterCard VISA

DESCRIPTION AND OPERATION

Identification Codes

The vehicle identification number (VIN) is a 17-digit combination of letters and numbers. The VIN is stamped on a metal tab riveted to the instrument panel, top upper left of the dash. The VIN number is also found on the vehicle certification (VC) label.

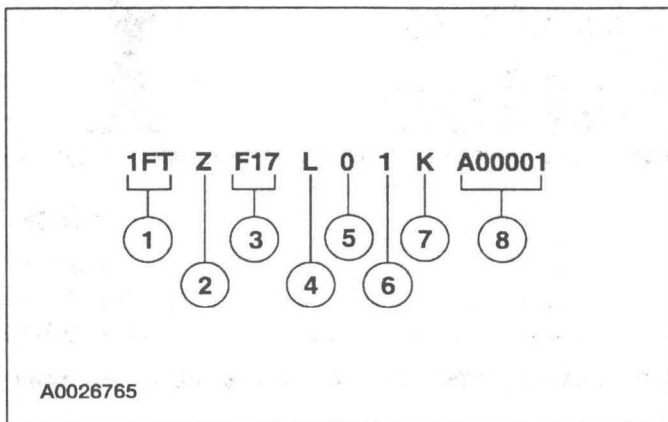

Item	Description
1	World manufacturer identifier (WMI)
2	Brake type and gross vehicle weight rating (GVWR), may also include the vehicle restraint type code
3	Vehicle line, series, body type code
4	Engine type code
5	Computer-generated check digit
6	Model year code
7	Assembly plant code
8	Production sequence number

Vehicle Identification Number

World Manufacturer Identifier

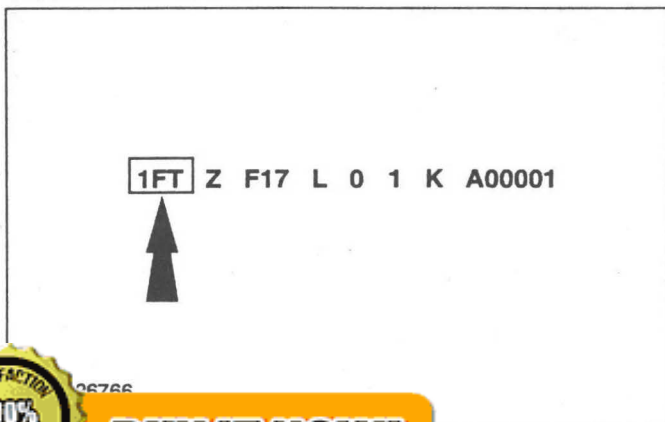

The first three vehicle identification number (VIN) positions are the world manufacturer identifier.

- 1FT — Ford Motor Company, USA, truck, completed vehicle
- 1FD — Ford Motor Company, USA, incomplete vehicle
- 2FT — Ford Motor Company, Canada, truck, completed vehicle
- 2FD — Ford Motor Company, Canada, incomplete vehicle
- 3FT — Ford Motor Company, Mexico, truck, completed vehicle
- 3FE — Ford Motor Company, Mexico, incomplete vehicle

Brake and Gross Vehicle Weight Code

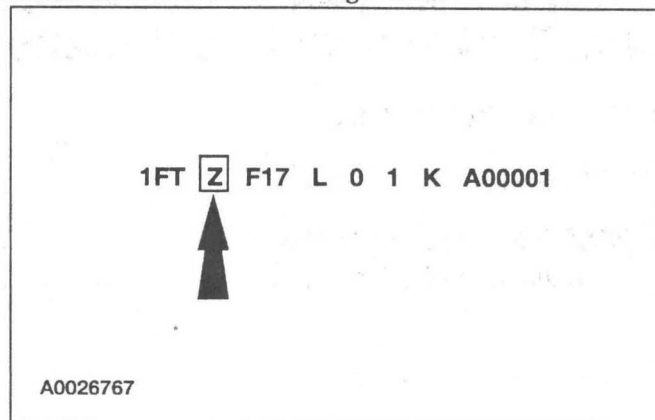

The fourth VIN position is the vehicle brake type and GVWR code (all vehicles use hydraulic brakes).

- Z — 5,001-6,000 pounds GVWR with driver and front passenger air bags
- R — 6,001-7,000 pounds GVWR with driver and front passenger air bags
- P — 7,001-8,000 pounds GVWR with driver and front passenger air bags



BUY IT NOW!

Click Here To Order



DESCRIPTION AND OPERATION (Continued)

Line, Series and Body Type

1FT Z **F17** L 0 1 K A00001

↑

A0026768

Positions 5 through 7 indicate vehicle line, series and body type.

- F07 — Regular Cab, 4x2, Flareside
- X07 — SuperCab, 4x2, Flareside
- F08 — Regular Cab, 4x4, Flareside
- X08 — SuperCab, 4x4, Flareside
- F17 — Regular Cab, 4x2, Styleside
- X17 — SuperCab, 4x2, Styleside
- F18 — Regular Cab, 4x4, Styleside
- X18 — SuperCab, 4x4, Styleside
- W07 — Crew Cab, 4x2, Flareside
- W08 — Crew Cab, 4x4, Flareside

Engine Code

1FT Z F17 **L** 0 1 K A00001

↑

A0026769

The eighth VIN position is the engine displacement and number of cylinders.

- 2 — 4.2L, OHV, V6, Gas
- W — 4.6L, SOHC, V8, Gas (Romeo)
- L — 5.4L, SOHC, V8, Gas
- M — 5.4L, SOHC, V8, Natural Gas
- Z — 5.4L, Bi-Fuel, V8 (Natural Gas/Propane)
- 3 — 5.4L, SOHC, V8, Gas (Lightning)

Check Digit

1FT Z F17 L **0** 1 K A00001

↑

A0026770

The ninth VIN position is a government assigned, computer-generated check digit.

Model Year

1FT Z F17 L 0 **1** K A00001

↑

A0026771

100% SATISFACTION GUARANTEED

BUY IT NOW!

Click Here To Order

PayPal American Express Discover MasterCard VISA

DESCRIPTION AND OPERATION (Continued)

The tenth VIN position is the model year code.

- 1 — 2001

Assembly Plant Code

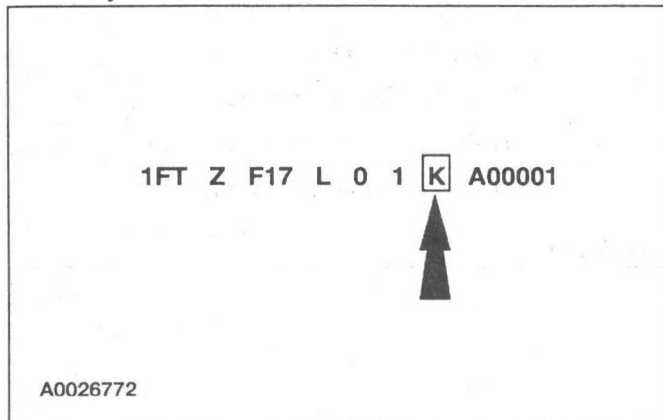

The eleventh VIN position is the assembly plant code.

- C — Ontario Truck (Oakville, Ontario)
- K — Kansas City (Claycomo, Missouri)
- N — Norfolk (Norfolk, Virginia)
- M — Cuautitlan (Cuautitlan, Mexico)

Vehicle Serial Number

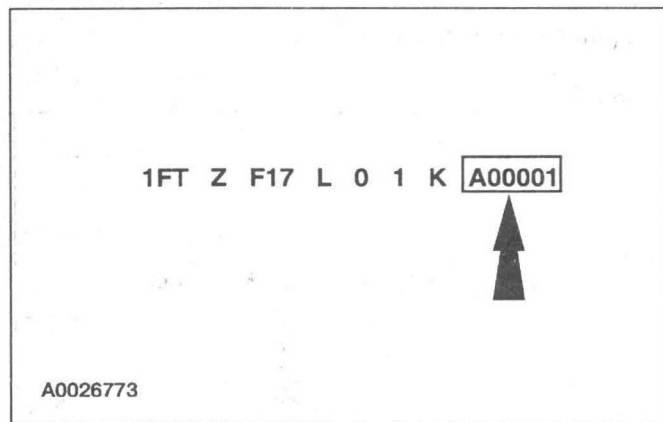

The last six VIN positions are an alphanumeric code for the vehicle build sequence. This is also the vehicle serial and warranty number.

Vehicle Certification (VC) Label

MFD. BY FORD MOTOR CO. IN U.S.A.

DATE: 01/98 GVWR: XXXXXXXXXXXXXXXX
 FRONT GAWR: XXXXXXXX REAR GAWR: XXXXXXXX
 WITH XXXXXXXX WITH XXXXXXXX
 XXXXXXXXXXXX TIRES XXXXXXXXXXXX TIRES
 XXXXXXXX RIMS XXXXXXXX RIMS
 AT XXXX kPa/XXX PSI COLD AT XXXX kPa/XXX PSI COLD
 XXXX

THIS VEHICLE CONFORMS TO ALL APPLICABLE FEDERAL MOTOR VEHICLE SAFETY STANDARDS IN EFFECT ON THE DATE OF MANUFACTURE SHOWN ABOVE.
 VIN: XXXXXXXXXXXXXXXXXXXX
 TYPE: XXXXXXXXXXXXXXXXXXXX

EXT PNT: XXXXXXXX XXXXXXXX RC: XX DSO: XXXX
 WB | BRK | INT | TR | TP/PS | R | AXLE | TR | SPR | XXXX
 XXX | X | XX | XXX | X | XX | X | XXXX | XXXX
 ↑ ↑ ↑ ↑ ↑ ↑ ↑ ↑ ↑ ↑ ↑ ↑
 4 5 6 7 8 9 10 11 12

A0008272

Item	Description
1	Exterior paint code
2	Region code
3	Domestic special order code
4	Wheelbase code
5	Brake type code
6	Interior trim code
7	Tape/paint stripe code
8	Radio code
9	Axle code

(Continued)



DESCRIPTION AND OPERATION (Continued)

Item	Description
10	Transmission code
11	Spring code
12	Powertrain calibration information

The vehicle certification (VC) label contains the manufacturer name, the month and year of manufacture, the certification statement, and the VIN. It also includes gross vehicle weight ratings (GVWR).

Vehicle Certification (VC) Label — Canada (Typical)

MFD. BY FORD MOTOR CO. OF CANADA, LTD.
 DATE: 01/98 GVWR/PNBV: XXXXXXXXXXXXXXXXXXXX
 FRONT GAWR / REAR GAWR
 PNBE AV PNBE AR
 XXXXXXXX XXXXXXXX
 XXXXXXXX XXXXXXXX
 WITH/AVEC TIRES/PNEUS
 XXXXXXXXXXXXXXXX / XXXXXXXXXXXXXXXX
 XXXXXXXXXXXX RIMS/JANTES XXXXXXXXXXXX
 AT/A kPa/PSI/LPC XXXXX/XXX COLD/A FROID XXXX/XXX
 XXXX/JUMELÉES
 VIN: XXXXXXXXXXXXXXXXXXXX XXXXX
 TYPE: XXXXXXXXXXXXXXXXXXXX COMPLIES: ICES-2 XXXXX





EXT PNT: XXXXXX XXXXXX | RC: XX | DSO: XXXX
 WB | BRK | INT | TR | TP/PS | R | AXLE | TR | SPR | XXXXX
 XXX X XX XXX X XX X XXXXX XXXXX
 A0008273 MADE IN CANADA CCT ∇ F85B-1520472-AB

Vehicle Certification (VC) Label — Mexico (Typical)

MFD. BY FORD MOTOR COMPANY
 DATE: XXXXX GVWR: XXXXXXXXXXXXXXXXXXXX
 FRONT GAWR: XXXXXXX XXXXXXX
 REAR GAWR: XXXXXXX XXXXXXX

 VIN: XXXXXXXXXXXXXXXXXXXX XXXXX
 TYPE: XXXXXXXXXXXXXXXXXXXX XXXXX



EXT PNT: XXXXXX XXXXXX | RC: XX | DSO: XXXX
 WB | BRK | INT | TR | TP/PS | R | AXLE | TR | SPR | XXXXX
 XXX X XX XXX X XX X XXXXX XXXXX
 A0008274 MADE IN MEXICO MPE ∇ F85B-1520472-AB

Vehicle Certification (VC) Label — Incomplete Vehicle (Typical)

INCOMPLETE VEHICLE MANUFACTURED BY
 FORD MOTOR COMPANY
 DATE: XXXXX GVWR: XXXXXXXXXXXXXXXXXXXX
 FRONT GAWR: XXXXXXX REAR GAWR: XXXXXXX
 XXXXXXX WITH XXXXXXX WITH
 XXXXXXXXXXXX TIRES XXXXXXXXXXXX TIRES
 XXXXXXXXXXXX RIMS XXXXXXXXXXXX RIMS
 AT XXXX kPa/XXX PSI COLD AT XXXX kPa/XXX PSI COLD
 VIN: XXXXXXXXXXXXXXXXXXXX XXXXX
 XXXXXXXXXXXXXXXXXXXXXXXXXXXXXXXXXXXX XXXXX



DSO: XXXX
 SPR | XXXXX
 XXXXX XXXXX
 ∇ F85B-1520472-AB

Exterior Paint

MFD. BY FORD MOTOR CO. IN U.S.A.

DATE: 01/98 GVWR: XXXXXXXXXXXXXXXXXXXX
 FRONT GAWR: XXXXXXX WITH REAR GAWR: XXXXXXX
 XXXXXXX WITH XXXXXXX WITH
 XXXXXXXXXXXX TIRES XXXXXXXXXXXX TIRES
 XXXXXXX RIMS XXXXXXX RIMS
 AT XXXX kPa/XXX PSI COLD AT XXXX kPa/XXX PSI COLD
 XXXX

THIS VEHICLE CONFORMS TO ALL APPLICABLE FEDERAL MOTOR VEHICLE SAFETY STANDARDS IN EFFECT ON THE DATE OF MANUFACTURE SHOWN ABOVE.
 VIN: XXXXXXXXXXXXXXXXXXXX
 TYPE: XXXXXXXXXXXXXXXXXXXX



EXT PNT: XXXXXXX XXXXXXX | RC: XX | DSO: XXXX
 WB | BRK | INT | TR | TP/PS | R | AXLE | TR | SPR | XXXXX
 XXX X XX XXX X XX X XXXXX XXXXX
 UTC ∇ F85B-1520472-AB

A0018017

Paint Codes

Exterior paint color codes may be listed as a two-part code. The first set of paint code characters indicate the primary body color. The second set of paint code characters (if applicable), indicate a two-tone body color or accent body color.

Primary Body Color

- E4 — Vermilion, clear coat
- B4 — Chestnut, clear coat
- FL — Medium Toreador Red, clear coat
- LL — Deep Wedgewood Blue, clear coat
- R1 — Island Blue, clear coat
- YN — Silver Metallic, clear coat
- UA — Ebony, clear coat
- YZ — Oxford White, clear coat
- Y1 — Prime
- AQ — Arizona Beige
- PX — Dark Highland Green
- ST — Estate Green (King Ranch)



BUY IT NOW!

Click Here To Order



DESCRIPTION AND OPERATION (Continued)

- KW — Charcoal Blue (King Ranch)
- EP — Vermilion, Mexico build
- GX — Toreador Red, Mexico build
- RH — Medium Platinum, Mexico build
- PK — Chesapeake Blue, Mexico build
- PB — Jewel Green Metallic, Mexico build
- TX — Bright Silver, Mexico build
- Y0 — Oxford White, Mexico build
- B2 — Harvest Gold
- SU — Amazon Green

- 120 — 120-inch wheelbase, regular cab
- 139 — 139-inch wheelbase, regular cab, SuperCab, Crew Cab
- 157 — 157-inch wheelbase, SuperCab

Wheelbase

MFD. BY FORD MOTOR CO. IN U.S.A.

DATE: 01/98 GVWR: XXXXXXXXXXXXXXXX
 FRONT GAWR: XXXXXXXX REAR GAWR: XXXXXXXX
 XXXXXXXX WITH XXXXXXXX WITH
 XXXXXXXXXXXXXXXX TIRES XXXXXXXXXXXXXXXX TIRES
 XXXXXXXX RIMS XXXXXXXX RIMS
 AT XXXX kPa/XXX PSI COLD AT XXXX kPa/XXX PSI COLD
 XXXX

THIS VEHICLE CONFORMS TO ALL APPLICABLE FEDERAL MOTOR VEHICLE SAFETY STANDARDS IN EFFECT ON THE DATE OF MANUFACTURE SHOWN ABOVE.
 VIN: XXXXXXXXXXXXXXXX XXXXX
 TYPE: XXXXXXXXXXXXXXXX XXXXX



EXT PNT: XXXXXXXX XXXXXXXX RC: XX DSO: XXXX
 WB | BRK | INT | TR | TP/PS | R | AXLE | TR | SPR | XXXXX
 XXX X XX XXX X XX X XXXX XXXX
 UTC ▽ F85B-1520472-AB

A0018018

Brake Type

MFD. BY FORD MOTOR CO. IN U.S.A.

DATE: 01/98 GVWR: XXXXXXXXXXXXXXXX
 FRONT GAWR: XXXXXXXX REAR GAWR: XXXXXXXX
 XXXXXXXX WITH XXXXXXXX WITH
 XXXXXXXXXXXXXXXX TIRES XXXXXXXXXXXXXXXX TIRES
 XXXXXXXX RIMS XXXXXXXX RIMS
 AT XXXX kPa/XXX PSI COLD AT XXXX kPa/XXX PSI COLD
 XXXX

THIS VEHICLE CONFORMS TO ALL APPLICABLE FEDERAL MOTOR VEHICLE SAFETY STANDARDS IN EFFECT ON THE DATE OF MANUFACTURE SHOWN ABOVE.
 VIN: XXXXXXXXXXXXXXXX XXXXX
 TYPE: XXXXXXXXXXXXXXXX XXXXX



EXT PNT: XXXXXXXX XXXXXXXX RC: XX DSO: XXXX
 WB | BRK | INT | TR | TP/PS | R | AXLE | TR | SPR | XXXXX
 XXX X XX XXX X XX X XXXX XXXX
 UTC ▽ F85B-1520472-AB

A0018019

- 3 — Four-wheel anti-lock brake system (ABS)
- 4 — Rear-wheel anti-lock brake system (RABS)

100% SATISFACTION GUARANTEED

BUY IT NOW!

Click Here To Order



DESCRIPTION AND OPERATION (Continued)

- E — Arizona Beige/Deep Sandlewood Metallic (Lariat)
- F — Deep Sandlewood Metallic/Arizona Beige (Lariat)

- R — Radio chassis only (AM/FM stereo with clock and cassette)
- D — Radio chassis only (AM/FM stereo with compact disc (CD) changer and cassette)
- X — Radio chassis only (AM/FM premium stereo with compact disc (CD) player and cassette)

Radio Type

MFD. BY FORD MOTOR CO. IN U.S.A.

DATE: 01/98 GVWR: XXXXXXXXXXXXX
 FRONT GAWR: XXXXXXXX REAR GAWR: XXXXXXXX
 XXXXXXXX WITH XXXXXXXX WITH
 XXXXXXXXXXXXX TIRES XXXXXXXXXXXXX TIRES
 XXXXXXXX RIMS XXXXXXXX RIMS
 AT XXXX kPa/XXX PSI COLD AT XXXX kPa/XXX PSI COLD
XXXX

THIS VEHICLE CONFORMS TO ALL APPLICABLE FEDERAL MOTOR VEHICLE SAFETY STANDARDS IN EFFECT ON THE DATE OF MANUFACTURE SHOWN ABOVE.
 VIN: XXXXXXXXXXXXXXXXXXXX XXXXX
 TYPE: XXXXXXXXXXXXXXXXXXXX XXXXX



EXT PNT: XXXXXXXX XXXXXXXX RC: XX DSO: XXXX
 WB | BRK | INT | TR | TP/PS | R | AXLE | TR | SPR | XXXXX
 XXX | X | XX XXX | X XX | X XXXXX XXXXX
↑ UTC ▽ F85B-1520472-AB

A0018022

- 7 — AM/FM stereo with clock (Mexico)
- 9 — AM/FM stereo with clock and cassette (Mexico)
- 5 — AM/FM premium stereo with clock and compact disc (CD) player
- E — AM/FM premium stereo with compact disc (CD) changer and cassette
- A — AM/FM stereo with clock and cassette
- Y — Radio chassis only (standard radio with clock)
- G — Radio chassis only (AM/FM stereo with clock)

Axle Type

MFD. BY FORD MOTOR CO. IN U.S.A.

DATE: 01/98 GVWR: XXXXXXXXXXXXX
 FRONT GAWR: XXXXXXXX REAR GAWR: XXXXXXXX
 XXXXXXXX WITH XXXXXXXX WITH
 XXXXXXXXXXXXX TIRES XXXXXXXXXXXXX TIRES
 XXXXXXXX RIMS XXXXXXXX RIMS
 AT XXXX kPa/XXX PSI COLD AT XXXX kPa/XXX PSI COLD
XXXX

THIS VEHICLE CONFORMS TO ALL APPLICABLE FEDERAL MOTOR VEHICLE SAFETY STANDARDS IN EFFECT ON THE DATE OF MANUFACTURE SHOWN ABOVE.
 VIN: XXXXXXXXXXXXXXXXXXXX XXXXX
 TYPE: XXXXXXXXXXXXXXXXXXXX XXXXX



EXT PNT: XXXXXXXX XXXXXXXX RC: XX DSO: XXXX
 WB | BRK | INT | TR | TP/PS | R | AXLE | TR | SPR | XXXXX
 XXX | X | XX XXX | X XX | X XXXXX XXXXX
↑ UTC ▽ F85B-1520472-AB

A0018023

- 18 — 3.08, non-limited slip
- 19 — 3.55, non-limited slip
- 26 — 3.73, non-limited slip
- 27 — 3.31, non-limited slip
- H9 — 3.55, limited slip
- B6 — 3.73, limited slip

100% SATISFACTORY GUARANTEED

BUY IT NOW!

Click Here To Order 





DESCRIPTION AND OPERATION (Continued)

Transmission Type

MFD. BY FORD MOTOR CO. IN U.S.A.

DATE: 01/98	GVWR: XXXXXXXXXXXXXXX		
FRONT GAWR: XXXXXXX	REAR GAWR: XXXXXXX		
XXXXXXXXXX	WITH	XXXXXXXXXX	WITH
XXXXXXXXXXXX	TIRES	XXXXXXXXXXXX	TIRES
XXXXXXXXXX	RIMS	XXXXXXXXXX	RIMS
AT XXXX kPa/XXX PSI COLD		AT XXXX kPa/XXX PSI COLD	XXXX

THIS VEHICLE CONFORMS TO ALL APPLICABLE FEDERAL MOTOR VEHICLE SAFETY STANDARDS IN EFFECT ON THE DATE OF MANUFACTURE SHOWN ABOVE.

VIN: XXXXXXXXXXXXXXXXXXXX
TYPE: XXXXXXXXXXXXXXXXXXXX



EXT PNT: XXXXXXX XXXXXXX	RC: XX	DSO: XXXX	
WB BRK INT TR TP/PS R AXLE TR SPR XXXXX			
XXX X XX XXX X XX X XXXX XXXX			
	UTC	↑ F85B-1520472-AB	

A0018024

Spring Codes

MFD. BY FORD MOTOR CO. IN U.S.A.

DATE: 01/98	GVWR: XXXXXXXXXXXXXXX		
FRONT GAWR: XXXXXXX	REAR GAWR: XXXXXXX		
XXXXXXXXXX	WITH	XXXXXXXXXX	WITH
XXXXXXXXXXXX	TIRES	XXXXXXXXXXXX	TIRES
XXXXXXXXXX	RIMS	XXXXXXXXXX	RIMS
AT XXXX kPa/XXX PSI COLD		AT XXXX kPa/XXX PSI COLD	XXXX

THIS VEHICLE CONFORMS TO ALL APPLICABLE FEDERAL MOTOR VEHICLE SAFETY STANDARDS IN EFFECT ON THE DATE OF MANUFACTURE SHOWN ABOVE.

VIN: XXXXXXXXXXXXXXXXXXXX
TYPE: XXXXXXXXXXXXXXXXXXXX



EXT PNT: XXXXXXX XXXXXXX	RC: XX	DSO: XXXX	
WB BRK INT TR TP/PS R AXLE TR SPR XXXXX			
XXX X XX XXX X XX X XXXX XXXX			
	UTC	↑ F B-1520472-AB	

A0018025

Spring codes are listed as a two-part code. The first characters listed identify the front springs or torsion bars. The second character listed identifies the rear springs.

-
- M — five-speed manual overdrive (Mazda M5R2-C)
- U — four-speed automatic (AODE, W/4R70W)
- E — four-speed automatic (4R100)
- 7 — four-speed automatic (4R100), Lightning



BUY IT NOW!

Click Here To Order



DESCRIPTION AND OPERATION (Continued)

Front Springs

- Base part number — 5310

Front Torsion Bars

- Base part number — 5B326 (right-hand), 5B327 (left-hand)

Rear Springs

- Base part number — 5560

Powertrain Calibration Information

NOTE: Powertrain calibration information is limited to a maximum of five characters per line on the vehicle certification label. Because of this, calibration identification consisting of more than five characters will wrap to the second line on the VC label.

Powertrain calibration information is printed in the lower right corner of the vehicle certification label. Only the base calibration information is printed. Revision levels will not appear, however, they can be found in On Line Automotive Service Information System (OASIS). For the current model year, Ford Motor Company is using three different protocols which describe powertrain base calibration. These protocols are designed to provide worldwide standardization for vehicle calibration. If the electronic calibration strategy was introduced in 1998 and carried into the current model year, Protocol 1 will be used. Refer to Protocol 1 below. If the electronic calibration strategy was introduced in 1999 and is carried into the current model year, Protocol 2 will be used. Refer to Protocol 2 below. For new electronic calibration strategies introduced in 2000 or 2001 use Protocol 3. Refer to Protocol 3 below.

MFD. BY FORD MOTOR CO. IN U.S.A.

DATE: 01/98	GVWR: XXXXXXXXXXXXXXX
FRONT GAWR: XXXXXXX	REAR GAWR: XXXXXXX
XXXXXXXX	WITH XXXXXXX WITH
XXXXXXXXXXXX	TIRES XXXXXXXXXXXX TIRES
XXXXXXXX	RIMS XXXXXXX RIMS
AT XXXX kPa/XXX PSI COLD	AT XXXX kPa/XXX PSI COLD XXXX

THIS VEHICLE CONFORMS TO ALL APPLICABLE FEDERAL MOTOR VEHICLE SAFETY STANDARDS IN EFFECT ON THE DATE OF MANUFACTURE SHOWN ABOVE.

VIN: XXXXXXXXXXXXXXX
 TYPE: XXXXXXXXXXXXXXX

XXXXX
 XXXXX



EXT PNT: XXXXXXX XXXXXXX	RC: XX	DSO: XXXX
WB BRK INT TR TP/PS R AXLE TR SPR XXXXX		
XXX X XX XXX X XX X XXXX XXXXX		

UTC

1520472-AB

A0010077

Protocol 1

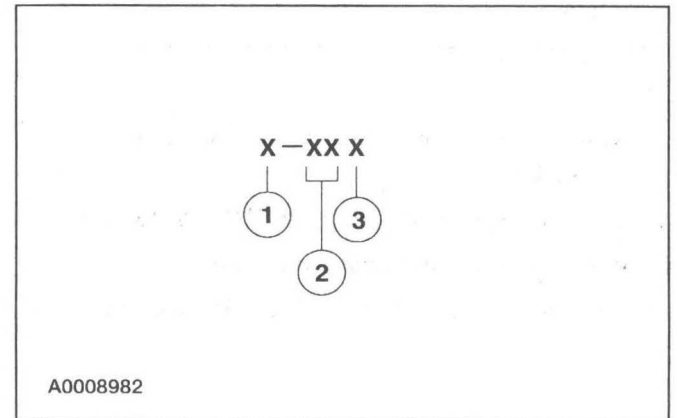

100% SATISFACTION GUARANTEED

BUY IT NOW!

Click Here To Order



DESCRIPTION AND OPERATION (Continued)

Item	Description
1	Model year (model year in which calibration strategy was first introduced)
2	Engine code
3	Engine revision level

Protocol 2

X XX X - X X

A0008983

Item	Description
1	Model year (model year in which calibration strategy was first introduced)
2	Engine code
3	Transmission code
4	Emission standard (designates the specific country emission standard)
5	Design level (design level assigned to the engine)

Protocol 3

X XX X XX X X XX

A0008984

Item	Description
1	Model year (model year in which calibration strategy was first introduced)

Item	Description
3	Transmission code
4	Unique calibration (designates different hardware to similar vehicles). Example: tires, drive ratios, etc.
5	Fleet code (describes fleet to which the vehicle belongs). Example: 6 - evaporative emissions
6	Certification region (lead region where multiple regions are included in one calibration). Example: A - U.S. federal
7	Revision level (will advance as revisions occur). Not printed on label

Protocol 3

The following offers a more detailed explanation of the coding strategy used in Protocol 3.

Model Year

- 0 — 2000
- 1 — 2001

Vehicle Line

- F5 — F-150

Transmission

- 1 — Automatic transmission
- 2 — Manual transmission

Unique Calibration

The Emissions/CAFE/CO2 Compliance Department is responsible for assigning these calibration numbers. Unique calibration identification identifications are assigned to cover similar vehicles to differentiate tires, drive configurations, final drive ratios and other calibration-significant factors.

These two characters are chosen by the analyst to provide identifiable information unique to each calibration. For example, using the number 2 to denote a two-valve engine versus using the number 4 to denote a four-valve engine, offers an easily identifiable difference.

Fleet Code

- 1 — HDGE/Dyno
- 2 — Fast AMA, U.S.
- 3 — ADP, U.S.
- 4 — Not assigned
- 5 — Not assigned
- 6 — Evaporative emissions

DESCRIPTION AND OPERATION (Continued)

- 7 — MACAA
- 8 — On-board diagnostics (OBD)
- 9 — Not assigned

Certification Region

Where multiple regions are included in one calibration, only the lead region will be listed.

- 5 — U.S. fifty states
- A — U.S. federal, including altitude, may include Canada and/or Mexico
- B — U.S. California standard, includes U.S. green states
- C — Canada
- D — China
- E — European Community (Austria, Belgium, Denmark, Finland, France, Germany, Greece, Ireland, Italy, Luxembourg, Netherlands, Portugal, Spain, Sweden and United Kingdom)
- F — Extended European Community (E plus Croatia, Czech Republic, Estonia, Hungary, Norway, Poland, Romania, Russian Federation, Slovakia, Slovenia, Switzerland and Yugoslavia)
- G — Gulf Cooperative Council (Bahrain, Kuwait, Oman, Qatar, Saudi Arabia and UAE)
- H — Hong Kong
- J — Japan

- K — Korea
- L — Malaysia
- M — Mexico
- N — New Zealand
- P — Australia
- Q — South America (Brazil)
- S — Singapore
- T — Taiwan
- U — South America (unleaded fuel regions)
- V — Vietnam
- Y — Military
- Z — Israel

Revision Level (not printed on label)

- 91-99 — Hardware calibration levels
- 01-04 — Preliminary levels
- 00 — Job 1 production (initial calibration)
- 05-09 — Pre-job 1 revisions to calibrations
- 10-89 — Post-job 1 revisions to calibrations
- 0B — Durability test level
- BD — On-board diagnostics (OBD) intermediate level (pre-05)



BUY IT NOW!

Click Here To Order



SECTION 100-02 Jacking and Lifting

VEHICLE APPLICATION: F150

CONTENTS

PAGE

DESCRIPTION AND OPERATION

Jacking	100-02-2
Lifting	100-02-3
Lifting Points — Twin Post Hoist	100-02-3



BUY IT NOW!
Click Here To Order



DESCRIPTION AND OPERATION

Jacking

⚠ WARNING: The electrical power to the air suspension system must be shut down prior to hoisting, jacking or towing an air suspension vehicle. This can be accomplished by turning off the air suspension switch located in the RH kick panel area. Failure to do so may result in unexpected inflation or deflation of the air springs which may result in shifting of the vehicle during these operations.

⚠ WARNING: Do not run the engine when jacking the vehicle. The wheels contacting the ground could cause the vehicle to move.

⚠ WARNING: Support the vehicle prior to performing any procedure requiring the vehicle to be jacked off the ground.

⚠ WARNING: Make sure the jack and jack stands are properly located to prevent the vehicle from falling.

⚠ WARNING: Wheel chocks should be used to prevent the vehicle from rolling and falling off the jack.

⚠ CAUTION: Never use a halfshaft as a lifting point.

Jacking Points — Front, 4x4

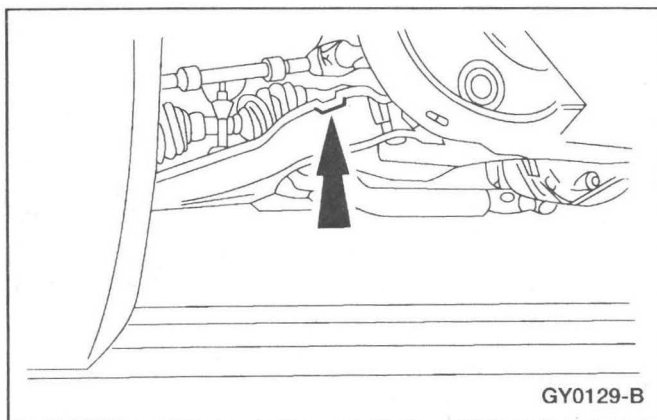

The jacking point is a raised boss located on the front suspension lower arm (3079).

Jacking Points — Front, 4x2

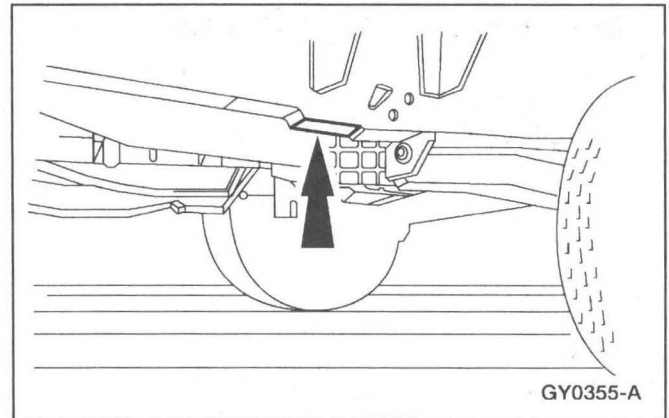

The jacking point is a flat portion on the frame indicated by the arrow cut out. The jacking point is located behind the front tire and wheel assembly.

Jacking Points — Rear

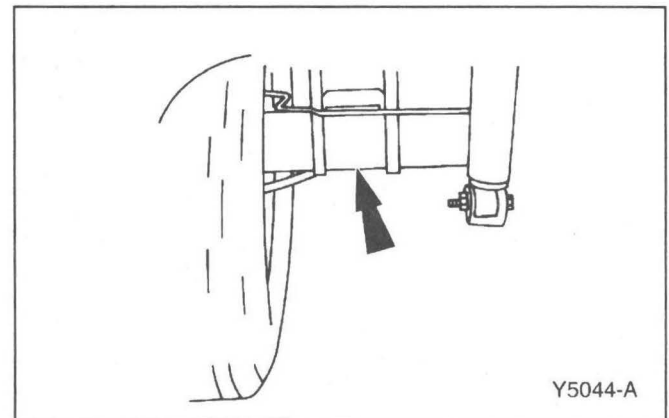

⚠ CAUTION: Never use the differential housing as a lifting point.

The rear jacking points are located on the rear axle (4001).

100% SATISFACTION GUARANTEED

BUY IT NOW!

Click Here To Order

PayPal Discover MasterCard VISA

DESCRIPTION AND OPERATION (Continued)**Lifting**

⚠ WARNING: The electrical power to the air suspension system must be shut off prior to hoisting, jacking or towing an air suspension vehicle. This can be accomplished by turning off the air suspension switch located in the RH kick panel area. Failure to do so may result in unexpected inflation or deflation of the air spring which may result in shifting of the vehicle during these procedures.

⚠ CAUTION: Damage to suspension, exhaust and steering linkage components may occur if care is not exercised when positioning the hoist adapters prior to lifting the vehicle.

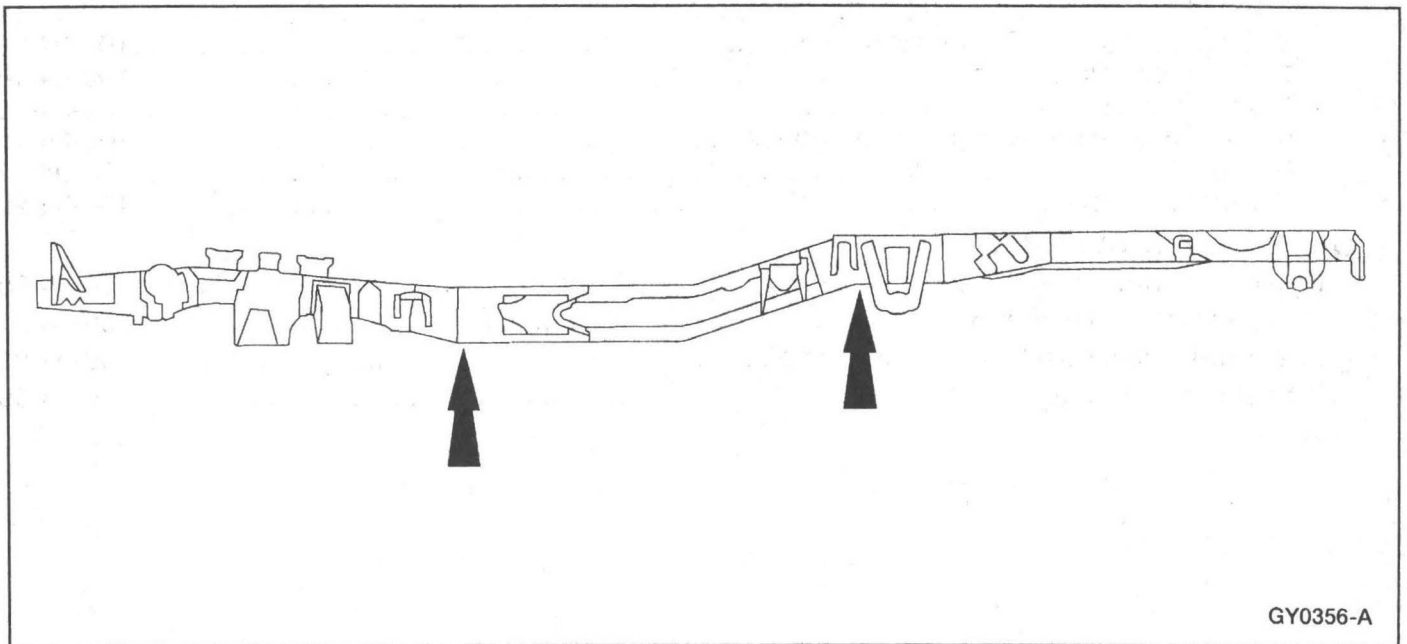
Lifting Points — Twin Post Hoist

GY0356-A

Locate the front hoist adapters and rear hoist adapters (top of frame arc) as indicated.

100% SATISFACTION GUARANTEED

BUY IT NOW!

Click Here To Order

PayPal American Express Discover MasterCard VISA

SECTION 100-04 Noise, Vibration and Harshness

VEHICLE APPLICATION: F150

CONTENTS	PAGE
DESCRIPTION AND OPERATION	
Noise, Vibration and Harshness (NVH)	100-04-2
Acceptable Noise, Vibration and Harshness	100-04-2
Diagnostic Theory	100-04-2
Glossary of Terms	100-04-2
Tools and Techniques	100-04-7
DIAGNOSIS AND TESTING	
Noise, Vibration and Harshness (NVH)	100-04-11
1: Customer Interview	100-04-15
2: Pre-Drive Check	100-04-15
3: Preparing for the Road Test	100-04-15
4: Verify the Customer Concern	100-04-15
5: Road Test	100-04-16
6: Check OASIS/TSBs/Repair History	100-04-18
7: Diagnostic Procedure	100-04-18
Component Tests	100-04-90
NVH Condition and Symptom Categories	100-04-18
Pinpoint Tests	100-04-57
Symptom Charts	100-04-20
GENERAL PROCEDURES	
Brake Disc Machining	100-04-95
Exhaust System Neutralizing	100-04-97
Powertrain/Drivetrain Mount Neutralizing	100-04-97
Wheel Bearing Check	100-04-99

100% SATISFACTORY GUARANTEED

BUY IT NOW!

Click Here To Order

PayPal American Express Discover MasterCard VISA

DESCRIPTION AND OPERATION

Noise, Vibration and Harshness (NVH)

Noise is any undesirable sound, usually unpleasant in nature. Vibration is any motion, shaking or trembling, that can be felt or seen when an object moves back and forth or up and down. Harshness is a ride quality issue where the vehicle's response to the road transmits sharply to the customer. Harshness normally describes a firmer than usual response from the suspension system. Noise, vibration and harshness (NVH) is a term used to describe these conditions, which result in varying degrees of dissatisfaction. Although, a certain level of NVH caused by road and environmental conditions is normal. This section is designed to aid in the diagnosis, testing and repair of NVH concerns.

Acceptable Noise, Vibration and Harshness

All internal combustion engines and drivelines produce some noise and vibration; operating in a real world environment adds noise that is not subject to control. Vibration isolators, mufflers and dampers reduce these to acceptable levels. A driver who is unfamiliar with a vehicle can think that some sounds are abnormal when actually the sounds are normal for the vehicle type. For example, Traction-Lok® differentials produce a slight noise on slow turns after extended highway driving. This is acceptable and has no detrimental effect on the locking axle function. As a technician, it is very important to be familiar with vehicle features and know how they relate to NVH concerns and their diagnosis. If, for example, the vehicle has automatic overdrive it is important to test drive the vehicle both in and out of overdrive mode.

Diagnostic Theory

The shortest route to an accurate diagnosis results from:

- system knowledge, including comparison with a known good system.
- system history, including repair history and usage patterns.
- condition history, especially any relationship to repairs or sudden change.
- knowledge of possible sources.
- using a systematic diagnostic method that divides the problem into related areas.

The diagnosis and correction of noise, vibration and harshness concerns requires:

- a road or system test to determine the exact nature of the concern.
- an analysis of the possible causes.
- testing to verify the cause.
- repairing any concerns found.
- a road test or system test to make sure the concern has been corrected or brought back to within an acceptable range.

Glossary of Terms

Acceleration-Light

An increase in speed at less than half throttle.

Acceleration-Medium

An increase in speed at half to nearly full throttle, such as 0-97 km/h (0-60 mph) in approximately 30 seconds.

Acceleration-Heavy

An increase in speed at one-half to full throttle, such as 0-97 km/h (0-60 mph) in approximately 20 seconds.

Ambient Temperature

The surrounding or prevailing temperature.

Amplitude

The quantity or amount of energy produced by a vibrating component (G force). An extreme vibration has a high amplitude. A mild vibration has a low amplitude.

Backlash

Gear teeth clearance.

Boom

Low frequency or low pitched noise often accompanied by a vibration. Also refer to Drumming.

Bound Up

An overstressed isolation (rubber) mount that transmits vibration/noise instead of absorbing it.

Brakes Applied

When the service brakes are applied with enough force to hold the vehicle against movement with the transmission in gear.

DESCRIPTION AND OPERATION (Continued)**Buffet/Buffering**

Strong noise fluctuations (less than 1000 Hz) caused by gusting winds. An example would be wind gusts against the side glass.

Buzz

A low-pitched sound like (200-5000 Hz) that from a bee. Often a metallic or hard plastic humming sound. Also describes a high frequency (200-800 Hz) vibration. Vibration feels similar to an electric razor.

Camber

The angle of the wheel in relation to the true vertical as measured looking from the front of the vehicle. Camber is positive when the wheel angle is offset so that the top of the wheel is positioned away from the vehicle.

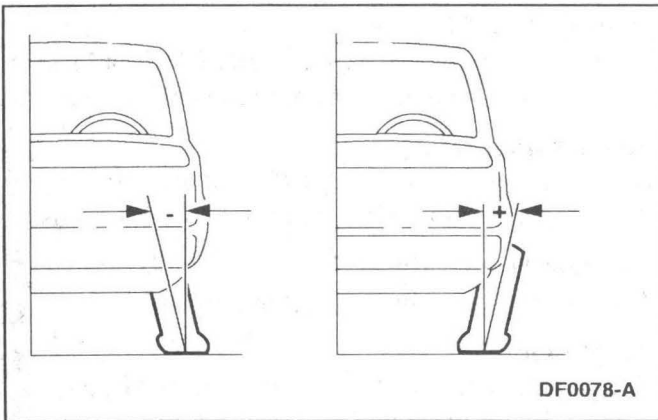
**Caster**

The angle of the steering knuckle in relation to the true vertical as measured looking from the side of the vehicle.

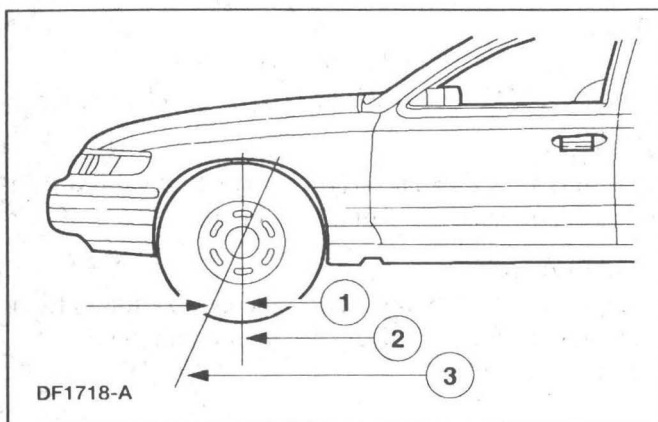
**Chatter**

A pronounced series of rapidly repeating rattling or clicking sounds.

Chirp

A short-duration high-pitched noise associated with a slipping drive belt.

Chuckle

A repetitious low-pitched sound. A loud chuckle is usually described as a knock.

Click

A sharp, brief, non-resonant sound, similar to actuating a ball point pen.

Clonk

A hydraulic knocking sound. Sound occurs with air pockets in a hydraulic system. Also described as hammering.

Clunk/Driveline Clunk

A heavy or dull, short-duration, low-frequency sound. Occurs mostly on a vehicle that is accelerating or decelerating abruptly. Also described as a thunk.

Coast/Deceleration

Releasing the accelerator pedal at cruise, allowing the engine to reduce vehicle speed without applying the brakes.

Coast/Neutral Coast

Placing the transmission range selector in NEUTRAL (N) or depressing the clutch pedal while at cruise.

Constant Velocity (CV) Joint

A joint used to absorb vibrations caused by driving power being transmitted at an angle.

Controlled Rear Suspension Height

The height at which a designated vehicle element must be when driveline angle measurements are made.

Coupling Shaft

The shaft between the transfer case and the front drive axle or, in a two-piece rear driveshaft, the front section.

CPS

Cycles per second. Same as hertz (Hz).

Cracks

A mid-frequency sound, related to squeak. Sound varies with temperature conditions.

Creak

A metallic squeak.

Item	Description
	Positive caster
	True vertical
	Steering axis



BUY IT NOW!

Click Here To Order



DESCRIPTION AND OPERATION (Continued)

Cruise

Constant speed on level ground; neither accelerating nor decelerating.

Cycle

The process of a vibrating component going through a complete range of motion and returning to the starting point.

Decibel

A unit of measurement, referring to sound pressure level, abbreviated dB.

Drive Engine Run-Up (DERU) Test

The operation of the engine through the normal rpm range with the vehicle standing still, the brakes applied and the transmission engaged. This test is used for noise and vibration checks.

Driveline Angles

The differences of alignment between the transmission output shaft, the driveshaft, and the rear axle pinion centerline.

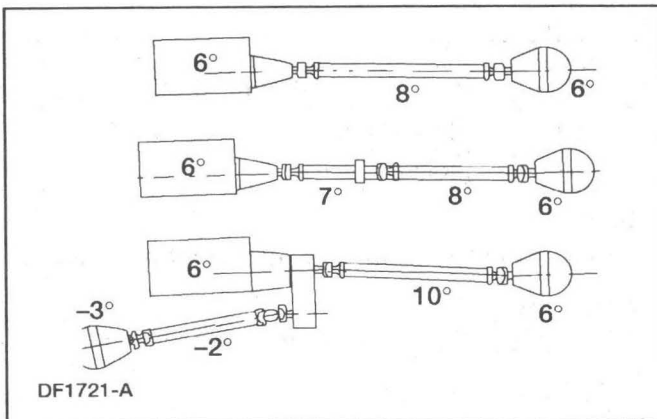

Driveshaft

The shaft that transmits power to the rear axle input shaft (pinion shaft). In a two-piece driveshaft, it is the rearmost shaft.

Drivetrain

All power transmitting components from the engine to the wheels; includes the clutch or torque converter, the transmission, the transfer case, the driveshaft, and the front or rear drive axle.

Drivetrain Damper

A weight attached to the engine, the transmission, the transfer case, or the axle. It is tuned by weight and placement to absorb vibration.

Drumming

A cycling, low-frequency (20-100 Hz), rhythmic noise often accompanied by a sensation of pressure on the ear drums. Also described as a low rumble, boom, or rolling thunder.

Dynamic Balance

The equal distribution of weight on each side of the centerline, so that when the wheel and tire assembly spins, there is no tendency for the assembly to move from side-to-side (wobble). Dynamically unbalanced wheel and tire assemblies can cause wheel shimmy.

Engine Imbalance

A condition in which an engine's center mass is not concentric to the rotation center, causing excessive motion.

Engine Misfire

When combustion in one or more cylinders does not occur or occurs at the wrong time.

Engine Shake

An exaggerated engine movement or vibration that directly increases in frequency as the engine speed increases. It is caused by non-equal distribution of mass in the rotating or reciprocating components.

Flexible Coupling

A flexible joint.

Float

A drive mode on the dividing line between cruise and coast where the throttle setting matches the engine speed with the road speed.

Flutter

Mid to high (100-2000 Hz) intermittent sound due to air flow. Similar to a flag flapping in the wind.

Frequency

The rate at which a cycle occurs within a given time.

Gravelly Feel

A grinding or growl in a component, similar to the feel experienced when driving on gravel.

Grind

An abrasive sound, similar to using a grinding wheel, or rubbing sand paper against wood.

Hiss

Steady high frequency (200-800 Hz) noise. Vacuum leak sound.

Hoot

A steady low frequency tone (50-500 Hz), sounds like blowing over a long neck bottle.



BUY IT NOW!

Click Here To Order



DESCRIPTION AND OPERATION (Continued)**Howl**

A mid-range frequency (200-800 Hz) noise between drumming and whine. Also described as a hum.

Hum

Mid-frequency (200-800 Hz) steady sound, like a small fan motor. Also described as a howl.

Hz

Hertz; a frequency measured in cycles per second.

Imbalance

Out of balance; heavier on one side than the other. In a rotating component, imbalance often causes vibration.

Inboard

Toward the centerline of the vehicle.

Intensity

The physical quality of sound that relates to the strength of the vibration (measured in decibels). The higher the sound's amplitude, the higher the intensity and vice versa.

Isolate

To separate the influence of one component to another.

Knock

A heavy, loud, repetitious sound, like a knock on the door.

Moan

A constant, low-frequency (100-200 Hz) tone. Also described as a hum.

Neutral Engine Run-Up (NERU) Test

The operation of the engine through the normal rpm range with the vehicle standing still and the transmission disengaged. This test is used to identify engine related vibrations.

Neutralize/Normalize

To return to an unstressed position. Used to describe mounts. Refer to Bound Up.

Outboard

Away from the centerline of the vehicle.

Ping

A short duration, high-frequency sound, which has a slight echo.

Pinion Shaft

The input shaft in a driving axle that is usually a part of the smaller driving or input hypoid gear of a ring and pinion gearset.

Pitch

The physical quality of sound that relates to its frequency. Pitch increases as frequency increases and vice versa.

Pumping Feel

A slow, pulsing movement.

Radial/Lateral

Radial is in the plane of rotation; lateral is at 90 degrees to the plane of rotation.

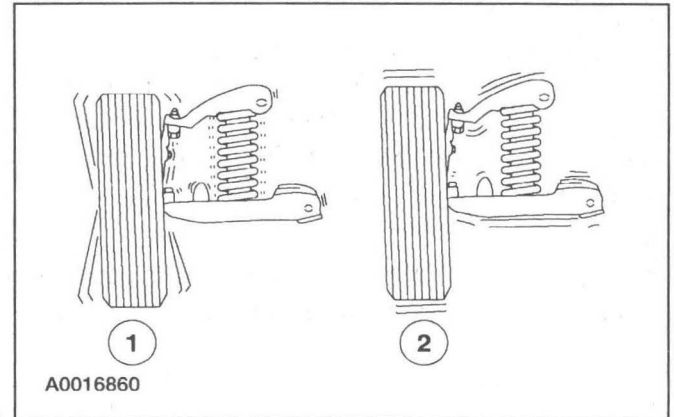

Item	Description
1	Lateral runout
2	Radial runout

Rattle

A random and momentary or short duration noise.

Ring Gear

The large, circular, driven gear in a ring and pinion gearset.

Road Test

The operation of the vehicle under conditions intended to produce the concern under investigation.

Roughness

A medium-frequency vibration. A slightly higher frequency (20 to 50 Hz) than a shake. This type of vibration is usually related to drivetrain components.

Runout

Lateral runout means measuring the movement or "wobble" of a wheel or tire at the sidewall. Radial runout means measuring the out-of-round at the tread surface.



BUY IT NOW!

Click Here To Order



DESCRIPTION AND OPERATION (Continued)**Rustling**

Intermittent sound of varying frequency (100-2000 Hz), sounds similar to shuffling through leaves.

Shake

A low-frequency vibration (5-20 Hz), usually with visible component movement. Usually relates to tires, wheels, brake drums or brake discs if it is vehicle speed sensitive, or engine if it is engine speed sensitive. Also referred to as a shimmy or wobble.

Shimmy

An abnormal vibration or wobbling, felt as a side-to-side motion of the steering wheel in the driveshaft rotation. Also described as waddle.

Shudder

A low-frequency vibration that is felt through the steering wheel or seat during light brake application.

Slap

A resonance from flat surfaces, such as safety belt webbing or door trim panels.

Slip Yoke/Slip Spline

The driveshaft coupling that allows length changes to occur while the suspension articulates and while the driveshaft rotates.

Squeak

A high-pitched transient sound, similar to rubbing fingers against a clean window.

Squeal

A long-duration, high-pitched noise.

Static Balance

The equal distribution of weight around the wheel. Statically unbalanced wheel and tire assemblies can cause a bouncing action called wheel tramp. This condition will eventually cause uneven tire wear.

Tap

A light, rhythmic, or intermittent hammering sound, similar to tapping a pencil on a table edge.

Thump

A dull beat caused by two items striking together.

Tick

A rhythmic tap, similar to a clock noise.

Tip-In Moan

A moaning noise heard during light vehicle acceleration, usually between 40-100 km/h (25-65 mph).

TIR

The acronym for total indicated runout is TIR.

Tire Deflection

The change in tire diameter in the area where the tire contacts the ground.

Tire Flat Spots

A condition commonly caused by letting the vehicle stand while the tires cool off. This condition can be corrected by driving the vehicle until the tires are warm. Also, irregular tire wear patterns in the tire tread resulting from wheel-locked skids.

Tire Force Vibration

A tire vibration caused by variations in the construction of the tire that is noticeable when the tire rotates against the pavement. This condition can be present on perfectly round tires because of variations in the inner tire construction. This condition can occur at wheel rotation frequency or twice rotation frequency.

Transient

A noise or vibration that is momentary, a short duration.

Two-Plane Balance

Radial and lateral balance.

Vibration

Any motion, shaking or trembling, that can be felt or seen when an object moves back and forth or up and down.

Whine

A constant, high-pitched noise. Also described as a screech.

Whistle

High-pitched noise (above 500 Hz) with a very narrow frequency band. Examples of whistle noises are a turbocharger or airflow around an antenna.

Wind Noise

Any noise caused by air movement in, out or around the vehicle.

WOT

The acronym for wide open throttle is WOT.



BUY IT NOW!

Click Here To Order



DESCRIPTION AND OPERATION (Continued)

Tools and Techniques

Vibration Analyzer (VA)

The VA is a hand-held electronic diagnostic tool which will assist in locating the source of unacceptable vibrations. The vibration sensor can be remotely mounted anywhere in the vehicle for testing purposes. The unit displays the three most common vibration frequencies and their corresponding amplitudes simultaneously. A bar graph provides a visual reference of the relative signal strength (amplitude) of each vibration being displayed and its relative G force. The keypad is arranged to make the VA simple to program and use. Some of the functions include the ability to average readings as well as record, play back and freeze readings. The VA has a strobe balancing function that can be used to detect imbalance on rotating components such as a driveshaft or engine accessories.

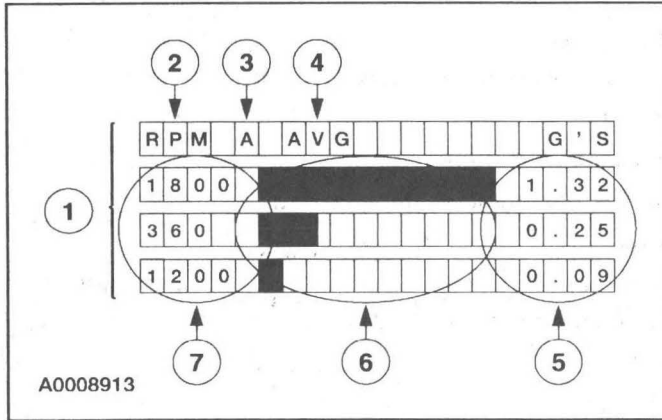

A0008913

Item	Description
1	VA screen
2	Frequency mode displayed in rpm or Hz
3	Active sensor input (A or B)
4	Current active mode
5	G force indicators or the strongest frequencies in descending strength of each vibration

(Continued)

Item	Description
6	Strength of each vibration
7	Frequency in rpm/Hz of each vibration

The VA allows for a systematic collection of information that is necessary to accurately diagnose and repair NVH problems. For the best results, carry out the test as follows:

- Test drive the vehicle with the vibration sensor inside the vehicle.
- Place the sensor in the vehicle according to feel.
 - If the condition is felt through the steering wheel, the source is most likely in the front of the vehicle.
 - A vibration that is felt in the seat or floor only will most likely be found in the driveline, drive axle or rear wheels and tires.
- Record the readings. Also note when the condition begins, when it reaches maximum intensity, and if it tends to diminish above/below a certain speed.
 - Frequencies should be read in the "average" mode.
 - Frequencies have a range of plus or minus 2. A reading of 10 Hz can be displayed as an 8 Hz through 12 Hz.
- Determine what the normal frequency is for the vehicle at a specified speed. Multiply the rear axle ratio by the Hz (1 Hz per every 5 mph). Example: A vehicle travelling 50 mph with a 3.08 rear axle ratio, the acceptable amount of Hz for the vehicle at that speed would be 10 (1 Hz per every 5 mph) X 3.08 (rear axle ratio) = 30.8 Hz.
- Place the vibration sensor on or near the suspect area outside the vehicle.
- Continue the road test, driving the vehicle at the speed the symptom occurs, and take another reading.

100% SATISFACTORY GUARANTEED

BUY IT NOW!

Click Here To Order

DESCRIPTION AND OPERATION (Continued)

- g. Compare the readings.
- A match in frequency indicates the problem component or area.
 - An unmatched test could indicate the concern is caused by the engine, torque converter, or engine accessory. Use the VA in the rpm mode and check if concern is rpm related.
 - Example: A vibration is felt in the seat. Place the sensor on the console. Record the readings. Place the vibration sensor on the rear axle. Compare the readings. If the frequencies are the same, the axle is the problem component. Also refer to the following chart as a reference to acceptable vibration and noise ranges for the specified components.

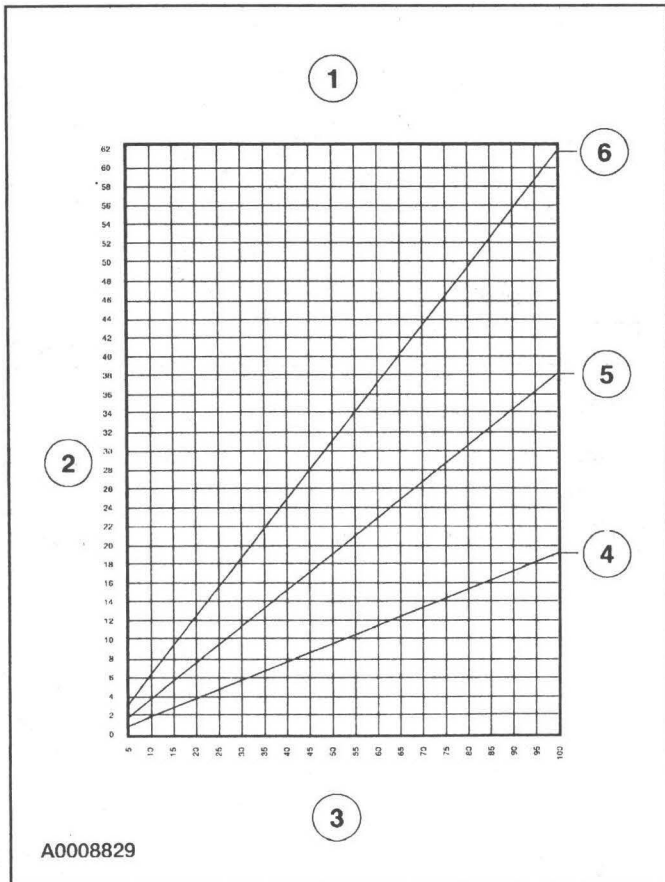

Item	Description
3	Miles per hour (mph)
4	First order tire (one disturbance for each revolution)
5	Second order tire (two disturbances for each revolution)
6	Driveline

Vibrate Software®

Vibrate software® (Rotunda tool number 215-00003) is a diagnostic aid which will assist in pinpointing the source of unacceptable vibrations. The engine's crankshaft is the point of reference for vibration diagnosis. Every rotating component will have an angular velocity that is faster, slower, or the same as the engine's crankshaft. Vibrate software® calculates the angular velocity of each component and graphically represents these velocities on a computer screen and on a printed vibration worksheet. The following steps outline how Vibrate software® helps diagnose a vibration concern:

- Enter the vehicle information. Vibrate will do all the calculations and display a graph showing tire, driveshaft and engine vibrations.
- Print a Vibration Worksheet graph. The printed graph is to be used during the road test.
- Road test the vehicle at the speed where the vibration is most noticeable. Record the vibration frequency (rpm) and the engine rpm on the worksheet graph. The point on the graph where the vibration frequency (rpm) reading and the engine rpm reading intersect indicates the specific component group causing the concern.
 - A VA or equivalent tool capable of measuring vibration frequency and engine rpm will be needed.
- Provide pictures of diagnostic procedures to aid in testing components.

ChassisEAR

An electronic listening device used to quickly identify noise and the location under the chassis while the vehicle is being road tested. The ChassisEARs can identify the noise and location of damaged/worn wheel bearings, CV joints, brakes, springs, axle bearings or driveshaft carrier bearings.

Item	Description
1	Acceptable vibration ranges for specified components
	Hertz (Hz)

100% SATISFACTION GUARANTEED

BUY IT NOW!

Click Here To Order

DESCRIPTION AND OPERATION (Continued)

EngineEAR

An electronic listening device used to detect even the faintest noises. The EngineEARs can detect the noise of damaged/worn bearings in generators, water pumps, A/C compressors and power steering pumps. They are also used to identify noisy lifters, exhaust manifold leaks, chipped gear teeth and for detecting wind noise. The EngineEAR has a sensing tip, amplifier, and headphones. The directional sensing tip is used to listen to the various components. Point the sensing tip at the suspect component and adjust the volume with the amplifier. Placing the tip in direct contact with a component will reveal structure-borne noise and vibrations, generated by or passing through, the component. Various volume levels can reveal different sounds.

Ultrasonic Leak Detector

The Ultrasonic Leak Detector is used to detect wind noises caused by leaks and gaps in areas where there is weather-stripping or other sealing material. It is also used to identify A/C leaks, vacuum leaks and evaporative emission noises. The Ultrasonic Leak Detector includes a multi-directional transmitter (operating in the ultrasonic range) and a hand-held detector. The transmitter is placed inside the vehicle. On the outside of the vehicle, the hand-held detector is used to sweep the area of the suspected leak. As the source of the leak is approached, a beeping sound is produced which increases in both speed and frequency.

Squeak and Rattle Repair Kit

The squeak and rattle repair kit (Rotunda tool number 164-R4900) contains lubricants and self-adhesive materials that can be used to eliminate interior and exterior squeaks and rattles. The kit consists of the following materials:

- PVC (soft foam) tape
- Urethane (hard foam) tape

- Flocked (black fuzzy) tape
- UHMW (frosted) tape
- Squeak and rattle oil tube
- Squeak and rattle grease tube

Tracing Powder

Tracing powder is used to check both the uniformity of contact and the tension of a seal against its sealing surface. These tests are usually done when a suspected air leak/noise appears to originate from the seal area or during the alignment and adjustment of a component to a weatherstrip. Tracing powder can be ordered from Crest Industries as ATR Leak Trace. Carry out the tracing powder test as follows:

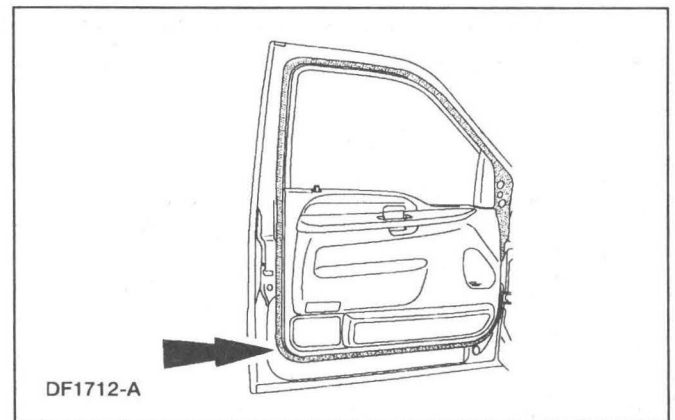

- Clean the weatherstrip.
- Spray the tracing powder on the mating surface only.
- Close the door completely. Do not slam the door.

100% SATISFACTION GUARANTEED

BUY IT NOW!

Click Here To Order

PayPal | American Express | Discover | MasterCard | VISA

DESCRIPTION AND OPERATION (Continued)

- d. Open the door. An imprint is made where the weatherstrip contacted the mating surface seal. Gaps or a faint imprint will show where there is poor contact with the weatherstrip.

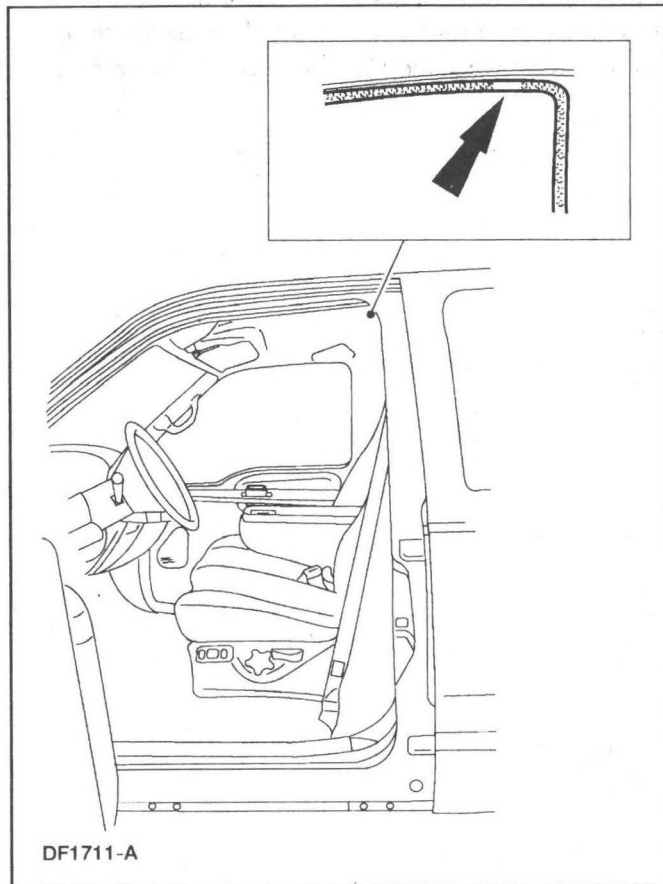
**Index Card**

Place an index card or a piece of paper between the weatherstrip and the sealing surface, then close the door. Slowly withdraw the index card or paper after the door is closed and check the amount of pressure on the weatherstrip. There should be a medium amount of resistance as it is withdrawn. Continue around the entire seal area. If there is little or no resistance, this indicates insufficient contact to form a good seal. At these points, the door, the glass, or the weatherstrip is out of alignment.

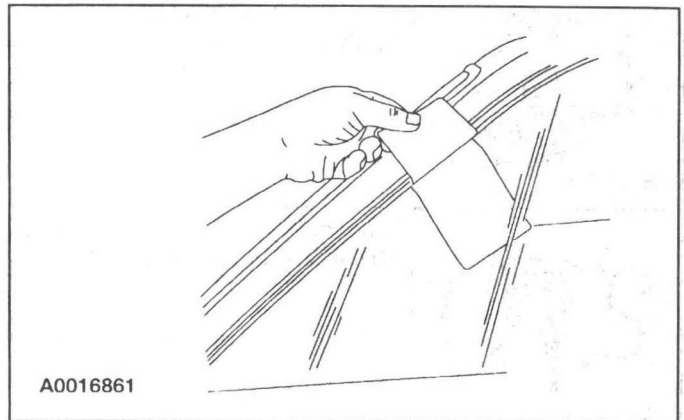

100% SATISFACTION GUARANTEED

BUY IT NOW!





Click Here To Order

PayPal Discover MasterCard VISA

DIAGNOSIS AND TESTING

Noise, Vibration and Harshness (NVH)

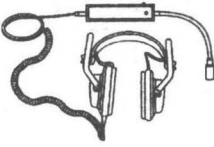
Special Tool(s)

 <p>ST2048-A</p>	<p>ChassisEAR 107-R2102 or Equivalent</p>
 <p>ST2311-A</p>	<p>Vibration Analyzer 100-F027 (014-00344) or Equivalent</p>
 <p>ST2312-A</p>	<p>EngineEAR 107-R2100 or Equivalent</p>
 <p>ST2314-A</p>	<p>Ultrasonic Leak Detector 134-R0135 or Equivalent</p>

To assist the service advisor and the technician, a Write-up Job Aid and an NVH Diagnostic Guide are included with this material. The Write-up Job Aid serves as a place to record all important symptom information. The NVH Diagnostic Guide serves as a place to record information reported on the Write-up Job Aid as well as data from the testing to be carried out.

100% SATISFACTION GUARANTEED

BUY IT NOW!

Click Here To Order 



DIAGNOSIS AND TESTING (Continued)

To begin a successful diagnosis, fill out the NVH Diagnostic Guide, record the reported findings, then proceed to each of the numbered process steps to complete the diagnosis.





"WRITE-UP" JOB AID

REPAIR ORDER # _____
 CUSTOMER CONCERN # _____

SPECIFIC SENSE IDENTIFICATION AND LOCATION ON VEHICLE OF CUSTOMER SYMPTOM(S)

INSTRUCTIONS: Check below sense affected and location of concern on the generic vehicle illustration (darken the vehicle area). Plus circle appropriate responses to the right.

NOTE: Shaded backgrounds indicate caution areas. Selection of two or more caution areas "flag" difficult repairs. In general, shaded areas are the more difficult to verify and repair, and require all applicable columns to be completed.

	SEE YES <input type="checkbox"/>		FEEL YES <input type="checkbox"/>
	HEAR YES <input type="checkbox"/>		SMELL YES <input type="checkbox"/>

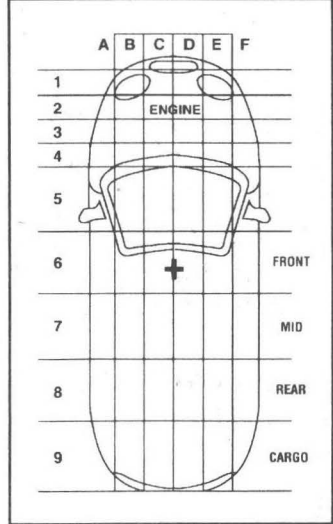

VEHICLE SYMPTOM AREA	HOW OFTEN?	VEHICLE OPERATING MODE	VEHICLE CONDITIONS	VEHICLE SPEED(mph)	WHEN VEHICLE IS?	AMBIENT CONDITION
Front of Vehicle	Always	Start Up	Accessories On (define below)	0	Turning Left	_____° Below Zero
Engine Compartment	Daily <input type="checkbox"/> A.M. <input type="checkbox"/> P.M.	Idle		1-9	Turning Right	Below Freezing (0°-19°)
Dash	<input type="checkbox"/> Conditional	Gear Selection	Windows Open	10-19	Over Bumps	Below Freezing (20°-32°)
Steering Wheel	<input type="checkbox"/> Weekly	Accel Light	4x4	20-29	Up Hills	33°-49°
Accelerator Pedal	<input type="checkbox"/> Monthly	Accel Moderate	Hauling	30-39	Down Hills	50°-69°
Brake Pedal	<input type="checkbox"/> Intermittent	Accel Heavy	Towing	40-49	Shifting	70°-89°
Clutch Pedal	<input type="checkbox"/> Unknown	Steady Speed	Snow Plowing	50-59	Parked	90°+
Seat		Deceleration	Other	60-69	In Traffic	Sunny
Rear of Vehicle		Neutral	(define below)	70+		Dry
Top of Vehicle		Reverse		ENGINE		
Floor Pan		Stopping/Braking		TEMP		Wet/Humid
Under Vehicle				Cold		Rain
Other (define below)				Normal		Snow
				Hot		Ice

DEALER VERIFICATION	WHAT THE CUSTOMER SAID
SERVICE ADVISOR <input type="checkbox"/> YES <input type="checkbox"/> NO	_____ _____ _____ _____ _____ _____ _____
SHOP FOREMAN <input type="checkbox"/> YES <input type="checkbox"/> NO	
SERVICE MANAGER <input type="checkbox"/> YES <input type="checkbox"/> NO	
QC MANAGER <input type="checkbox"/> YES <input type="checkbox"/> NO	
TECHNICIAN <input type="checkbox"/> YES <input type="checkbox"/> NO	
VERIFIED WITH CUSTOMER <input type="checkbox"/> YES <input type="checkbox"/> NO	
OASIS SYMPTOM CODE(S)	

OASIS SYMPTOM CODE(S) _____ _____	VIN NUMBER _____ _____
---	------------------------------

A0017007

100% SATISFACTION GUARANTEED

BUY IT NOW!

Click Here To Order







DIAGNOSIS AND TESTING (Continued)

NVH DIAGNOSTIC GUIDE

Dealer: _____ Date: _____

P.A. Code: _____ Order No. _____ Technician: _____

Owner's Name: _____ Address: _____

Phone No. Home: _____ Work: _____

Vehicle Make: _____ Model: _____ Year: _____

VIN: _____ Mileage: _____ Engine: _____ Trans: _____ Axle: _____

OWNER'S DESCRIPTION OF COMPLAINT:

Did Condition Exist When Vehicle Was New? Yes / No (circle one)

How Did Condition Begin? Gradually Suddenly

At What Mileage Did It Occur Or Begin Occuring? _____

Which Driving Conditions Affect The Vehicle?

- Light Accel Closed Throttle Decel Brakes Applied/Released
Medium Accel Coast (Float) Driving The Vehicle: Straight
Heavy Accel Constant Speed Cornering

Is Vibration Noticed? If So, Where:

- Seat Steering Wheel Instrument Panel Floor Body Panels Ft/Rr of Vehicle

Is There Sound Or Sensation Of Sound? Yes / No (circle one)

If So, Describe The Sound :

- Boom Hum Whine Growl Other: _____
Drone Tip-In-Moan Squeak Rattle

PREDRIVE CHECKS

Tire Condition/Pressure: _____

Vehicle Body Damage? _____

Other: _____

ROAD TEST:

Vibration/Noise Occurs:

Vehicle Speed _____ Accel _____ Vibration Frequency _____ Hz/RPM
Gear Range _____ Decel/Coast _____ Engine Speed _____ RPM

ENGINE RUN-UP TESTS

Neutral Engine Run-Up (NERU) Yes / No Engine RPM _____ Vibration/Frequency _____ Hz/RPM

Drive Engine Run-Up (DERU) Yes / No Engine RPM _____ Vibration/Frequency _____ Hz/RPM

Drivetrain Run-Up (DTRU) Yes / No Engine RPM _____ Vibration/Frequency _____ Hz/RPM

Indicate Suspected Area of Concern:

- Tire/Wheel/Brakes Engine/Accessory Rear
Driveline/Axle Susp/Steering Right
Body Front Left
Other _____

Equipment Used:

- Reed Tachometer Electronic Noise Detector Tape
Engine Tachometer Ultrasonic Leak Detector Other _____

DF1688-A

100% SATISFACTION GUARANTEED BUY IT NOW! Click Here To Order [PayPal, American Express, Discover, MasterCard, VISA logos]

DIAGNOSIS AND TESTING (Continued)

WHEEL/TIRE/BRAKES CHECK:

Balance Check Yes / No

Maximum Runout Allowed:

Wheel: Radial _____ Lateral _____

Tire: Radial _____ Lateral _____

Measured Runout:

Tire/Wheel Radial: LF _____ LR _____ RF _____ RR _____

Lateral: LF _____ LR _____ RF _____ RR _____

Wheel Only Radial: LF _____ LR _____ RF _____ RR _____

Lateral: LF _____ LR _____ RF _____ RR _____

SUSPENSION INSPECTION:

Can Cause: Shimmy Clunk Squeak Harshness

Suspension Bushings: Loose Worn Missing OK

Front Upper Control Arm Stabilizer (sway bar) Rear Lower Control Arm

Front Lower Control Arm Rear Upper Control Arm Rear Upper Control Arm

Other _____

Suspension/Steering Components: Loose Worn Missing OK

Ball Joints Idler Arm Pitman Arm

Shock Absorbers F/R Center Link Steering Gear

Springs F/R Tie Rod Ends/Sleeve Steering Coupler

DRIVESHAFT CONDITION: Noise Vibration

Balance Weights Missing/Other Visual Defects? Yes / No

Maximum Allowable Runout: _____

Actual Runout: Front _____ Middle _____ Rear _____

Two-Piece Driveshaft Runout: Front _____ Rear _____

Middle Support Bearing: Loose Damaged Worn Other _____

Suspect Driveshaft Balanced? Yes / No

Pinion Angle: Engine Height: Specification _____ Actual _____

Pinion Angle: Specification _____ Actual _____

Driveline Angle - Truck: Specification _____ Actual _____

ENGINE/ACCESSORY CHECK:

Visual Inspection for Damage or Grounded Condition:

Powertrain Mounts Fuel Lines A/C Lines Power Steering/Cooler Lines

Air Intake Accessories Exhaust Radiator/Condensator

BODY (NOISE/RATTLE)

Indicate Suspected Area of Concern: Doors Windows Dash Panel Other _____

Tests Used to Isolate

NVH Concern: Vacuum/Leak Detector Ultrasonic Leak Detector Tracing Powder

Electronic Noise Detector Other _____

ROAD/ENGINE RUN-UP TESTS: Improved? Yes / No Vehicle Acceptable? Yes / No

Comments: _____

14 SATISFACTION 100% GUARANTEED BUY IT NOW! Click Here To Order [PayPal, American Express, Discover, MasterCard, VISA logos]

DIAGNOSIS AND TESTING (Continued)

1: Customer Interview

The diagnostic process starts with the customer interview. The service advisor must obtain as much information as possible about the problem and take a test drive with the customer. There are many ways a customer will describe NVH concerns and this will help minimize confusion arising from descriptive language differences. It is important that the concern is correctly interpreted and the customer descriptions are recorded. During the interview, ask the following questions:

- When was it first noticed?
- Did it appear suddenly or gradually?
- Did any abnormal occurrence coincide with or precede its appearance?

Use the information gained from the customer to accurately begin the diagnostic process.

2: Pre-Drive Check

It is important to do a pre-drive check before road testing the vehicle. A pre-drive check verifies that the vehicle is relatively safe to drive and eliminates any obvious faults on the vehicle.

The pre-drive check consists of a brief visual inspection. During this brief inspection, take note of anything that will compromise safety during the road test and make those repairs/adjustments before taking the vehicle on the road.

3: Preparing for the Road Test

Observe the following when preparing for the road test:

- Review the information recorded on the NVH Diagnostic Guide. It is important to know the specific concern the customer has with the vehicle.
- Do not be misled by the reported location of the noise/vibration. The cause can actually be some distance away.

- Remember that the vibrating source component (originator) may only generate a small vibration. This small vibration can in turn cause a larger vibration/noise to emanate from another receiving component (reactor), due to contact with other components (transfer path).
- Conduct the road test on a quiet street where it is safe to duplicate the vibration/noise. The ideal testing route is an open, low-traffic area where it is possible to operate the vehicle at the speed in which the condition occurs.
- If possible, lower the radio antenna in order to minimize turbulence. Identify anything that could potentially make noise or be a source of wind noise. Inspect the vehicle for add-on items that create vibration/noise. Turn off the radio and the heating and cooling system blower.
- The engine speed is an important factor in arriving at a final conclusion. Therefore, connect an accurate tachometer to the engine, even if the vehicle has a tachometer. Use a tachometer that has clearly defined increments of less than 50 rpm. This ensures an exact engine speed reading.

4: Verify the Customer Concern

Verify the customer concern by carrying out a road test, an engine run-up test, or both.

The decision to carry out a road test, an engine run-up test, or both depends on the type of NVH concern. A road test may be necessary if the symptom relates to the suspension system or is sensitive to torque. A drive engine run-up (DERU) or a neutral engine run-up (NERU) test identifies noises and vibrations relating to engine and drivetrain rpm. Remember, a condition will not always be identifiable by carrying out these tests, however, they will eliminate many possibilities if carried out correctly.

SATISFACTION 100% GUARANTEED

BUY IT NOW!

Click Here To Order

PayPal American Express Discover MasterCard VISA

DIAGNOSIS AND TESTING (Continued)

5: Road Test

NOTE: It may be necessary to have the customer ride along or drive the vehicle to point out the concern. During the road test, take into consideration the customer's driving habits and the driving conditions. The customer's concern just may be an acceptable operating condition for that vehicle.

The following is a brief overview of each test in the order in which it appears. A review of this information helps to quickly identify the most appropriate process necessary to make a successful diagnosis. After reviewing this information, select and carry out the appropriate test(s), proceeding to the next step of this process.

- The Slow Acceleration Test is normally the first test to carry out when identifying an NVH concern, especially when a road test with the customer is not possible.
- The Heavy Acceleration Test helps to determine if the concern is torque-related.
- The Neutral Coast Down Speed Test helps to determine if the concern is vehicle speed-related.
- The Downshift Speed Test helps to determine if the concern is engine speed-related.
- The Steering Input Test helps to determine how the wheel bearings and other suspension components contribute to a vehicle speed-related concern.
- The Brake Test helps to identify vibrations or noise that are brake related.
- The Road Test Over Bumps helps isolate a noise that occurs when driving over a rough or bumpy surface.
- The Engine Run-Up Tests consist of the Neutral Run-Up Test and the Engine Load Test. These tests help to determine if the concern is engine speed-related.
- The Neutral Run-Up Test is used as a follow-up test to the Downshift Speed Test when the concern occurs at idle.
- The Engine Load Test helps to identify vibration/noise sensitive to engine load or torque. It also helps to reproduce engine speed-related concerns that cannot be duplicated when carrying out the Neutral Run-Up Test or the Neutral Coast Test.

- The Vehicle Cold Soak Procedure helps to identify concerns occurring during initial start-up and when an extended time lapse occurs between vehicle usage.

Slow Acceleration Test

To carry out this test, proceed as follows:

- Slowly accelerate to the speed where the reported concern occurs. Note the vehicle speed, the engine rpm and, if possible, determine the vibration frequency.
- Attempt to identify from what part of the vehicle the concern is coming.
- Attempt to identify the source of the concern.
- Proceed as necessary.

Heavy Acceleration Test

To carry out this test, proceed as follows:

- Accelerate hard from 0-64 km/h (0-40 mph).
- Decelerate in a lower gear.
- The concern is torque related if duplicated while carrying out this test.
- Proceed as necessary.

Neutral Coast Down Speed Test

To carry out this test, proceed as follows:

- Drive at a higher rate of speed than where the concern occurred when carrying out the Slow Acceleration Test.
- Place the transmission in NEUTRAL and coast down past the speed where the concern occurs.
- The concern is vehicle speed-related if duplicated while carrying out this test. This eliminates the engine and the torque converter as sources.
- If the concern was not duplicated while carrying out this test, carry out the Downshift Speed Test to verify if the concern is engine speed related.
- Proceed as necessary.

Downshift Speed Test

To carry out this test, proceed as follows:

- Shift into a lower gear than the gear used when carrying out the Slow Acceleration Test.
- Drive at the engine rpm where the concern occurs.

ocate faulty
the speed-related



BUY IT NOW!

Click Here To Order



DIAGNOSIS AND TESTING (Continued)

- The concern is engine speed related if duplicated while carrying out this test. This eliminates the tires, wheels, brakes and the suspension components as sources.
- If necessary, repeat this test using other gears and NEUTRAL to verify the results.
- Proceed as necessary.

Steering Input Test

To carry out this test, proceed as follows:

- Drive at the speed where the concern occurs, while making sweeping turns in both directions.
- If the concern goes away or gets worse, the wheel bearings, hubs, U-joints (contained in the axles of 4WD applications), and tire tread wear are all possible sources.
- Proceed as necessary.

Brake Test

To carry out this test, proceed as follows:

- Warm the brakes by slowing the vehicle a few times from 80-32 km/h (50-20 mph) using light braking applications. At highway speeds of 89-97 km/h (50-60 mph), apply the brake using a light pedal force.
- Accelerate to 89-97 km/h (55-60 mph).
- Lightly apply the brakes and slow the vehicle to 30 km/h (20 mph).
- A brake vibration noise can be felt in the steering wheel, seat or brake pedal. A brake noise can be heard upon brake application and diminish when the brake is released.

Road Test Over Bumps

To carry out this test, proceed as follows:

- Drive the vehicle over a bump or rough surface one wheel at a time to determine if the noise is coming from the front or the back and the left or the right side of the vehicle.
- Proceed as necessary.

Neutral Engine Run-Up (NERU) Test

To carry out this test, proceed as follows:

- Install a tachometer.
- Increase the engine rpm up from an idle to approximately 4000 rpm while in PARK on front wheel drive vehicles with automatic transmissions, or NEUTRAL for all other vehicles. Note the engine rpm and, if possible, determine the vibration frequency.
- Attempt to identify what part of the vehicle the concern is coming from.
- Attempt to identify the source of the concern.
- Proceed as necessary.

Drive Engine Run-Up (DERU) Load Test

To carry out this test, proceed as follows:

-  **WARNING: Block the front and rear wheels, and apply the parking brake and the service brake, or injury to personnel can result.**

 **CAUTION: Do not carry out the Engine Load Test for more than five seconds or damage to the transmission or transaxle can result.**
Block the front and rear wheels.

- Apply the parking brake and the service brake.
- Install a tachometer.
- Shift the transmission into DRIVE, and increase and decrease the engine rpm between an idle to approximately 2000 rpm. Note the engine rpm and, if possible, determine the vibration frequency.
- Repeat the test in REVERSE.
- If the vibration/noise is duplicated when carrying out this test, inspect the engine and transmission or transaxle mounts.
- If the concern is definitely engine speed-related, carry out the Engine Accessory Test to narrow down the source.
- Proceed as necessary.



100% SATISFACTION GUARANTEED

BUY IT NOW!

Click Here To Order

PayPal American Express Discover MasterCard VISA

DIAGNOSIS AND TESTING (Continued)

Operating Condition—Vehicle is Not Moving

1. Static operation
 - Noise occurs during component/system functioning. GO to **Symptom Chart — Squeak and Rattle**.
2. While cranking
 - 1 Grinding or whine, differential ring gear or starter motor pinion noise. GO to **Symptom Chart — Engine Noise/Vibration**.
 - 2 Rattle. Exhaust hanger, exhaust heat shield or A/C line noise. GO to **Symptom Chart — Squeak and Rattle**.
 - 3 Vibration. Acceptable condition.
3. At idle
 - Idle noise. GO to **Symptom Chart — Idle Noise/Vibration**.
 - Idle vibration or shake. GO to **Symptom Chart — Idle Noise/Vibration**.
4. During Gear Selection
 - 1 Vehicle parked on a steep incline. Acceptable noise.
 - 2 Vehicle parked on a flat surface. GO to **Symptom Chart — Driveline Noise/Vibration**.
 - 3 Vehicle with a manual transmission. GO to **Symptom Chart — Transmission (Manual) and Transfer Case Noise/Vibration**.

Operating Condition—Vehicle is Moving

1. Depends more on how the vehicle is operated
 - 1 Speed related
 - Related to vehicle speed
 - Pitch increases with vehicle speed. GO to **Symptom Chart — Tire Noise/Vibration**.
 - Noise occurs at specific vehicle speed. A high-pitched noise (whine). GO to **Symptom Chart — Driveline Noise/Vibration**.
 - Loudness proportional to vehicle speed. Low-frequency noise at high speeds, noise and loudness increase with speed. GO to **Symptom Chart — Driveline Noise/Vibration**.

- A low-pitched noise (drumming). GO to **Symptom Chart — Engine Noise/Vibration**.
- Vibration occurs at a particular speed (mph) regardless of acceleration or deceleration. GO to **Symptom Chart — Tire Noise/Vibration**.
- Noise varies with wind/vehicle speed and direction. GO to **Symptom Chart — Air Leak and Wind Noise**.

- Related to engine speed.

- Noise varies with engine rpm. GO to **Symptom Chart — Engine Noise/Vibration**.
- Vibration occurs at a particular speed (mph) regardless of engine speed (rpm).

- 2 Acceleration

- Wide open throttle (WOT)

- Engine induced contact between components. Inspect and repair as necessary.
- Noise is continuous throughout WOT. Exhaust system or engine ground out. GO to **Symptom Chart — Engine Noise/Vibration**.

- Light/moderate acceleration

- Tip-in moan. Engine/exhaust noise. GO to **Symptom Chart — Engine Noise/Vibration**.
- Knock-type noise. GO to **Symptom Chart — Engine Noise/Vibration**.
- Driveline shudder. GO to **Symptom Chart — Driveline Noise/Vibration**.
- Engine vibration. GO to **Symptom Chart — Engine Noise/Vibration**.

- 3 Turning noise GO to **Symptom Chart — Steering Noise/Vibration**.

- 4 Braking

- Clicking sound is signaling ABS is active. Acceptable ABS sound.



BUY IT NOW!

Click Here To Order



DIAGNOSIS AND TESTING (Continued)

- A continuous grinding/squeal. GO to **Symptom Chart — Brake Noise/Vibration.**
 - Brake vibration/shudder. GO to **Symptom Chart — Brake Noise/Vibration.**
- 5 Clutching
- A noise occurring during clutch operation. GO to **Symptom Chart — Transmission (Manual) and Transfer Case Noise/Vibration.**
 - Vibration. GO to **Symptom Chart — Transmission (Manual) and Transfer Case Noise/Vibration.**
- 6 Shifting
- Noise or vibration condition related to the transmission (automatic). GO to **Symptom Chart — Transmission (Automatic) Noise/Vibration.**
 - Noise or vibration related to the transmission (manual). GO to **Symptom Chart — Transmission (Manual) and Transfer Case Noise/Vibration.**
- 7 Engaged in four-wheel drive. GO to **Symptom Chart — Transmission (Manual) and Transfer Case Noise/Vibration.**
- 8 Cruising speeds
- Accelerator pedal vibration. GO to **Symptom Chart — Engine Noise/Vibration.**
 - Driveline vibration. GO to **Symptom Chart — Driveline Noise/Vibration.**
 - A shimmy or shake. GO to **Symptom Chart — Tire Noise/Vibration.**
- 9 Driving at low/medium speeds
- A wobble or shudder. GO to **Symptom Chart — Tire Noise/Vibration.**
2. Depends more on where the vehicle is operated
- 1 Bump/pothole, rough road or smooth road. GO to **Symptom Chart — Suspension Noise/Vibration.**
- Noise is random or intermittent occurring from road irregularities. GO to **Symptom Chart — Squeak and Rattle.**
 - Noise or vibration changes from one road surface to another. Normal sound changes.
 - Noise or vibration associated with a hard/firm ride. GO to **Symptom Chart — Suspension Noise/Vibration.**

Symptom Charts**Symptom Chart — Air Leak and Wind Noise**

Condition	Possible Sources	Action
<ul style="list-style-type: none"> • Air leak around door perimeter 	<ul style="list-style-type: none"> • Loose fit seal. • Seal installed incorrectly. • Door misaligned. • Scuff plate installed incorrectly. • Seal or seal push pins damaged. 	<ul style="list-style-type: none"> • PINCH the seal carrier to improve retention on the seal flange. • REINSTALL the seal. • REALIGN the door. CHECK door gaps and fit in the door opening and ADJUST as necessary. • REINSTALL the scuff plate. • INSTALL a new seal.



DIAGNOSIS AND TESTING (Continued)**Symptom Chart — Air Leak and Wind Noise (Continued)**

Condition	Possible Sources	Action
<ul style="list-style-type: none"> Air leak around glass run 	<ul style="list-style-type: none"> Door glass misaligned. Glass run installed incorrectly. Leak path behind glass run. Glass run channel spread wide. Blow-out clip bent or contacting door glass. Glass run damaged. 	<ul style="list-style-type: none"> ADJUST the door glass. ADJUST the glass run. INSERT foam in the glass run carrier. INSTALL foam rope behind the glass run. PINCH the glass run channel to reduce the size of the opening. ADJUST the blow-out clip or INSTALL a new glass run/blow-out clip molding assembly. INSTALL a new glass run.
<ul style="list-style-type: none"> Air leak at inner belt line 	<ul style="list-style-type: none"> Belt line seal installed incorrectly on flange. Belt line seal integrated with door trim installed incorrectly (no glass contact). No contact with side glass. No contact with glass runs at both ends of belt line seal. Belt line seal damaged. 	<ul style="list-style-type: none"> ADJUST the seal. (Do not bend the flange.) REINSTALL the door trim. ADJUST the door glass. ADJUST the belt line seal or ADD foam at the seal ends. INSTALL a new seal.
<ul style="list-style-type: none"> Air leak at outer belt line 	<ul style="list-style-type: none"> Belt line seal installed incorrectly on flange (no glass contact). Belt line seal does not contact the glass. No contact with glass runs at both ends of belt line seal. Belt line seal damaged. 	<ul style="list-style-type: none"> ADJUST the seal. ADJUST the door glass. ADJUST the belt line seal/ADD foam at the seal ends. INSTALL a new seal.
<ul style="list-style-type: none"> Draft at inner door handle/speaker opening 	<ul style="list-style-type: none"> Hole in watershield. Watershield misaligned. Exterior door handle seal misaligned/damaged. 	<ul style="list-style-type: none"> SEAL the hole with a suitable tape. REALIGN the watershield. INSTALL a new watershield if the pressure sensitive adhesive fails. REALIGN or INSTALL a new seal as necessary.



BUY IT NOW!

Click Here To Order



DIAGNOSIS AND TESTING (Continued)**Symptom Chart — Air Leak and Wind Noise (Continued)**

Condition	Possible Sources	Action
<ul style="list-style-type: none"> Wind noise from side view mirror 	<ul style="list-style-type: none"> Outside mirror housing misaligned. Mirror sail gasket folded/misaligned. Mirror housing trim cap installed incorrectly. Air leak through mirror housing hinge. Inner sail trim installed incorrectly. Inner sail gasket/barrier installed incorrectly. Air path through wiring bundle/fastener access holes. Exposed fastener access hole on mirror housing/sail. 	<ul style="list-style-type: none"> REALIGN with the edges shingled correctly and no gaps. REINSTALL with the gasket unfolded and aligned correctly. REINSTALL with the edges shingled to the air flow. Fully ENGAGE the mirror into its operating position/USE foam to block the air path through the hinge. REINSTALL the sail trim/ADJUST the door trim. REINSTALL the trim cover with the gasket/barrier aligned correctly. BLOCK the air path(s) with foam/tape. INSTALL a new cap if it is missing.
<ul style="list-style-type: none"> Air leak around perimeter of fixed glass 	<ul style="list-style-type: none"> Gaps in the sealant bead. Air traveling up windshield molding along A-pillar. Windshield/backlite misaligned or not installed correctly. Rear hood seal at base of windshield misaligned/damaged. 	<ul style="list-style-type: none"> APPLY approved sealant. INSTALL foam rope the full length of the A-pillar. REINSTALL the windshield/backlite. REALIGN or INSTALL a new seal as necessary.
<ul style="list-style-type: none"> Air leak at cowl 	<ul style="list-style-type: none"> Cowl gasket misaligned/damaged. 	<ul style="list-style-type: none"> REALIGN or INSTALL a new seal as necessary.
<ul style="list-style-type: none"> Air leak around liftgate perimeter 	<ul style="list-style-type: none"> Loose fit seal. Seal misaligned. Liftgate misaligned. Scuff plate misaligned. Seal or seal push pins damaged. 	<ul style="list-style-type: none"> PINCH the seal carrier to improve retention on the seal flange or INSERT foam in the carrier. REINSTALL the seal. REALIGN the liftgate. CHECK the liftgate fit in the body opening and ADJUST as necessary. REINSTALL the scuff plate. INSTALL a new seal.
<ul style="list-style-type: none"> Air leak around the liftgate flip window perimeter 	<ul style="list-style-type: none"> Loose fit seal. Seal misaligned. Glass misaligned. Seal damaged. 	<ul style="list-style-type: none"> PINCH the seal carrier to improve the retention to the seal flange. REINSTALL the seal. REALIGN the glass. INSTALL a new seal.
<ul style="list-style-type: none"> Wind noise from antenna 	<ul style="list-style-type: none"> Shape of antenna. Air leak around antenna cable access hole. 	<ul style="list-style-type: none"> INSTALL an antenna boot or a spiral antenna. INSPECT the antenna access hole grommet. REPAIR as necessary.



BUY IT NOW!

Click Here To Order



DIAGNOSIS AND TESTING (Continued)**Symptom Chart — Air Leak and Wind Noise (Continued)**

Condition	Possible Sources	Action
<ul style="list-style-type: none"> Air leak from closed roof opening panel 	<ul style="list-style-type: none"> Seal installed incorrectly. Roof opening panel glass/door misaligned. Roof opening panel damaged. 	<ul style="list-style-type: none"> REINSTALL the seal. REALIGN the roof opening panel glass/door. INSTALL a new roof opening panel.
<ul style="list-style-type: none"> Buffeting from an open roof opening panel 	<ul style="list-style-type: none"> Wind deflector inoperative/damaged. Wind deflector height incorrect. 	<ul style="list-style-type: none"> REPAIR or INSTALL a new wind deflector as necessary. ADJUST the wind deflector higher.
<ul style="list-style-type: none"> Wind noise created by airflow over or behind body panels 	<ul style="list-style-type: none"> Fender splash shield misaligned. Body panel misaligned (exposed edge). Hood misaligned (front margin). Front grille edge noise. 	<ul style="list-style-type: none"> REALIGN the fender splash shield. REALIGN the appropriate body panel. CHECK hood gaps and fit. ADJUST the hood as necessary. APPLY foam in the hollow areas behind the louvers.
<ul style="list-style-type: none"> Wind noise created by grille opening panel 	<ul style="list-style-type: none"> Grille relationship to leading edge on hood. Sharp edges due to material imperfections. 	<ul style="list-style-type: none"> ADJUST the grille opening panel forward to eliminate wind noise. REMOVE the sharp edges (no damage to visible surface).
<ul style="list-style-type: none"> Wind noise from air extractor 	<ul style="list-style-type: none"> Air extractor housing seated incorrectly. Air extractor housing or flaps damaged. 	<ul style="list-style-type: none"> REINSTALL the air extractor housing. INSTALL a new air extractor.
<ul style="list-style-type: none"> Air leak at top of A-pillar — vehicles with a convertible top 	<ul style="list-style-type: none"> Seal at windshield header installed incorrectly. Seal pinched. Gap between side rail and header seal at A-pillar. 	<ul style="list-style-type: none"> REINSTALL the seal. FILL the seal with foam to reshape it. ADJUST the J-hook/vinyl top.
<ul style="list-style-type: none"> Air leak at rear quarter glass (division bar) — vehicles with a convertible top 	<ul style="list-style-type: none"> No contact between front side glass and quarter glass division bar. 	<ul style="list-style-type: none"> ADJUST the front side glass regulator and the rear quarter glass regulator.
<ul style="list-style-type: none"> Air leak or wind noise from top of side glass — vehicles with a convertible top 	<ul style="list-style-type: none"> Gap between side rail and vinyl top. Seal at windshield header installed incorrectly. Seal damaged between side rail and vinyl top. Vinyl top damaged. 	<ul style="list-style-type: none"> ADD additional foam tape to seal between the side rail and the vinyl top. REINSTALL the seal. INSTALL a new seal. INSPECT the vinyl top. INSTALL a new vinyl top as necessary.
<ul style="list-style-type: none"> Air leak or wind noise at windshield header — vehicles with a convertible top 	<ul style="list-style-type: none"> Vinyl top not flush with header. Seal at windshield header installed incorrectly. Header seal not flush with header. 	<ul style="list-style-type: none"> ADJUST the J-hook to lower the top to achieve a flush condition. REINSTALL the seal. REINSTALL the seal.



BUY IT NOW!

Click Here To Order



DIAGNOSIS AND TESTING (Continued)**Symptom Chart — Air Leak and Wind Noise (Continued)**

Condition	Possible Sources	Action
<ul style="list-style-type: none"> Convertible top flapping with the top up 	<ul style="list-style-type: none"> Vinyl top contacting interior headliner. 	<ul style="list-style-type: none"> Working from front to back, INSTALL a 6.35 mm (0.25 in) foam sheet between the headliner and the vinyl top at the suspected area. Allow a clearance of 50 mm (2 in) - 75 mm (3 in) away from the roof bows and the side rails.
<ul style="list-style-type: none"> Noise from roof rack 	<ul style="list-style-type: none"> Roof rack rails or crossbars loose. Roof rack fasteners missing. Roof rack crossbars installed backward. Roof rack rub strips partially lifting from roof. Roof rack gaskets loose or misaligned. 	<ul style="list-style-type: none"> TIGHTEN the fasteners. INSTALL the approved fasteners. REINSTALL the crossbars. REAPPLY adhesive or fasteners or INSTALL new rub strips as necessary. REINSTALL the gasket.
<ul style="list-style-type: none"> Wind noise from bug shield/exterior windshield sun visor 	<ul style="list-style-type: none"> Turbulence created by location and shape. 	<ul style="list-style-type: none"> REMOVE per customer direction if it is a dealer installed option.

Symptom Chart—Brake Noise/Vibration

Condition	Possible Sources	Action
<ul style="list-style-type: none"> Rattling noise 	<ul style="list-style-type: none"> Caliper mounting bolts loose. Damaged or worn caliper pins or retainers. Missing or damaged anti-rattle clips or springs. Loose brake disc shield. 	<ul style="list-style-type: none"> CHECK the caliper bolts. TIGHTEN to specifications. REFER to Section 206-03 for front disc brakes or Section 206-04 for rear disc brakes. CHECK the caliper pins and retainers for lubrication and correct fit. LUBRICATE or INSTALL new components as necessary. REFER to Section 206-03 for front disc brakes or Section 206-04 for rear disc brakes. CHECK the brake pads for missing clips or broken springs. INSTALL new components as necessary. REFER to Section 206-03 for front disc brakes or Section 206-04 for rear disc brakes. TIGHTEN the brake disc shield bolts to specification. REFER to Section 206-03.
<ul style="list-style-type: none"> Clicking noise—with brakes applied with ABS brakes 	<ul style="list-style-type: none"> ABS hydraulic control unit. 	<ul style="list-style-type: none"> Acceptable condition.
<ul style="list-style-type: none"> Squealing noise—occurs on cold (morning) brake 	<ul style="list-style-type: none"> Disc brake pads. 	<ul style="list-style-type: none"> Acceptable condition. Caused by humidity and low disc brake pad temperature.

**BUY IT NOW!****Click Here To Order**

DIAGNOSIS AND TESTING (Continued)**Symptom Chart—Brake Noise/Vibration (Continued)**

Condition	Possible Sources	Action
<ul style="list-style-type: none"> Squealing noise—a continuous squeal 	<ul style="list-style-type: none"> Disc brake pads or linings worn below minimum thickness. 	<ul style="list-style-type: none"> INSTALL new disc brake pads. REFER to Section 206-03 for front disc brakes or Section 206-04 for rear disc brakes.
<ul style="list-style-type: none"> Squealing noise—an intermittent squeal brought on by cold, heat, water, mud or snow 	<ul style="list-style-type: none"> Disc brake pad. 	<ul style="list-style-type: none"> Acceptable condition.
<ul style="list-style-type: none"> Groaning noise—occurs at low speeds with brake lightly applied (creeping) 	<ul style="list-style-type: none"> Disc brake pads. 	<ul style="list-style-type: none"> Acceptable condition.
<ul style="list-style-type: none"> Grinding noise—continuous 	<ul style="list-style-type: none"> Disc brake pads or linings worn below minimum thickness. 	<ul style="list-style-type: none"> INSPECT the disc brake pads, brake discs/drums and attaching hardware for damage. REPAIR or INSTALL new components as necessary. REFER to Section 206-03 for front disc brakes or Section 206-04 for rear disc brakes.
<ul style="list-style-type: none"> Moaning noise 	<ul style="list-style-type: none"> Brake linings contaminated with grease or oil. 	<ul style="list-style-type: none"> INSPECT the brake pads and shoes for contamination. REPAIR or INSTALL new components as necessary. REFER to Section 206-03 for front disc brakes or Section 206-04 for rear disc brakes.
<ul style="list-style-type: none"> Brake vibration/shudder—occurs when brakes are applied 	<ul style="list-style-type: none"> Uneven disc or drum wear. Uneven disc brake pad or lining transfer. Suspension components. 	<ul style="list-style-type: none"> GO to Pinpoint Test A.
<ul style="list-style-type: none"> Brake vibration/shudder—occurs when the brake pedal is released 	<ul style="list-style-type: none"> Brake drag. 	<ul style="list-style-type: none"> INSPECT the disc brake pads or linings for premature wear. REPAIR or INSTALL a new caliper or wheel cylinder as necessary. REFER to Section 206-03 for front disc brakes or Section 206-04 for rear disc brakes.



BUY IT NOW!

Click Here To Order



DIAGNOSIS AND TESTING (Continued)**Symptom Chart—Driveline Noise/Vibration**

Condition	Possible Sources	Action
<ul style="list-style-type: none"> Axle howling or whine—front or rear axle 	<ul style="list-style-type: none"> Axle lubricant low. Axle housing damage. Damaged or worn wheel bearings or axle bearings. Damaged or worn differential ring and pinion. Damaged or worn differential side or pinion bearings. Damaged or worn differential side gears and pinion gears. 	<ul style="list-style-type: none"> CHECK the lubricant level. FILL the axle to specification. INSPECT the axle housing for damage. REPAIR or INSTALL a new axle as necessary. REFER to Section 205-02A for Ford 8.8 rear axles, Section 205-02B for Ford 9.75 rear axles, Section 205-02C for Ford 10.25 rear axles or Section 205-03 for front axles. CHECK for abnormal wheel bearing play or roughness. Refer to Wheel Bearing Check in this section. ADJUST or INSTALL new wheel bearings as necessary. INSPECT the ring and pinion ring for abnormal wear patterns or broken teeth. INSTALL a new ring and pinion as necessary. REFER to Section 205-02A for Ford 8.8 rear axles, Section 205-02B for Ford 9.75 rear axles, Section 205-02C for Ford 10.25 rear axles or Section 205-03 for front axles. CHECK for abnormal bearing play or roughness. INSTALL new bearings as necessary. REFER to Section 205-02A for Ford 8.8 rear axles, Section 205-02B for Ford 9.75 rear axles, Section 205-02C for Ford 10.25 rear axles or Section 205-03 for front axles. DISASSEMBLE the differential carrier. INSPECT the side and pinion gears for abnormal wear patterns or broken teeth. INSTALL new gears as necessary. REFER to Section 205-02A for Ford 8.8 rear axles, Section 205-02B for Ford 9.75 rear axles, Section 205-02C for Ford 10.25 rear axles or Section 205-03 for front axles.



BUY IT NOW!

Click Here To Order



DIAGNOSIS AND TESTING (Continued)**Symptom Chart—Driveline Noise/Vibration (Continued)**

Condition	Possible Sources	Action
<ul style="list-style-type: none"> • Driveline clunk—loud clunk when shifting from reverse to drive 	<ul style="list-style-type: none"> • Incorrect axle lubricant level. • Excessive backlash in the axle or transmission. • Damaged or worn pinion bearings. • Damaged or worn universal joints (U-joints). • Loose suspension components. • Broken powertrain mounts. • Idle speed too high. 	<ul style="list-style-type: none"> • CHECK the lubricant level. FILL the axle to specification. • CARRY OUT a total backlash check. REFER to Section 205-00. • CHECK for abnormal bearing play or roughness. INSTALL new bearings as necessary. REFER to Section 205-02A for Ford 8.8 rear axles, Section 205-02B for Ford 9.75 rear axles, Section 205-02C for Ford 10.25 rear axles or Section 205-03 for front axles. • INSPECT the U-joints for wear or damage. INSTALL new U-joints as necessary. REFER to Section 205-01. • INSPECT the suspension for damage or wear. REPAIR or INSTALL new components as necessary. • INSPECT the powertrain mounts. REFER to Section 303-01A for 4.2L engines or Section 303-01B for 4.6L and 5.4L engines. INSTALL new mounts as necessary. • CHECK for the correct idle speed.
<ul style="list-style-type: none"> • Driveline clunk—occurs as the vehicle starts to move forward following a stop 	<ul style="list-style-type: none"> • Worn or galled driveshaft slip-yoke splines. • Worn or galled driveshaft and coupling shaft splines. • Loose rear leaf spring U-bolts. 	<ul style="list-style-type: none"> • CLEAN and INSPECT the splines of the yoke for a worn or galled condition. INSTALL a new yoke as necessary. REFER to Section 205-01. • CLEAN and INSPECT the splines of the driveshaft and coupling shaft for a worn or galled condition. INSTALL a new driveshaft assembly as necessary. REFER to Section 205-01. • CHECK the U-bolts for loose nuts. TIGHTEN to specification. REFER to Section 204-02.
<ul style="list-style-type: none"> • Driveline clunk (FWD vehicles)—occurs during acceleration or from cruise to coast/deceleration 	<ul style="list-style-type: none"> • Damaged or worn inboard constant velocity (CV) joint. 	<ul style="list-style-type: none"> • INSPECT the inboard CV joint and boot. REPAIR or INSTALL a new CV joint as necessary.
<ul style="list-style-type: none"> • Driveline clunk (4WD vehicles)—occurs during 	<ul style="list-style-type: none"> • Clutch relay. • Shift motor. • Transfer case. • GEM. 	<ul style="list-style-type: none"> • CHECK the 4WD engagement system. REPAIR or INSTALL new components as necessary. REFER to Section 308-07A and Section 308-07B.



BUY IT NOW!

Click Here To Order



DIAGNOSIS AND TESTING (Continued)**Symptom Chart—Driveline Noise/Vibration (Continued)**

Condition	Possible Sources	Action
<ul style="list-style-type: none"> Clicking, popping or grinding—occurs while vehicle is turning 	<ul style="list-style-type: none"> Inadequate or contaminated lubrication in the (CV) joints. Another component contacting the halfshaft. Brake components. Steering components. Suspension components. Damaged or worn wheel bearings. 	<ul style="list-style-type: none"> CHECK the CV boots and joints for wear or damage. REPAIR or INSTALL new components as necessary. REFER to Section 205-04. CHECK the halfshafts and the area around the halfshafts. REPAIR as necessary. INSPECT the front brakes for wear or damage. REPAIR as necessary. REFER to Section 206-03. INSPECT the drag link, inner and outer tie-rods or idler arm for wear or damage. REPAIR as necessary. REFER to Section 211-03. INSPECT the upper and lower ball joints for wear or damage. REPAIR as necessary. REFER to Section 204-01A for 2-wheel drive vehicles or Section 204-01B for 4-wheel drive vehicles. CHECK for abnormal wheel bearing play or roughness. Refer to Wheel Bearing Check in this section. ADJUST or INSTALL new wheel bearings as necessary.
<ul style="list-style-type: none"> Clicking or snapping—occurs when accelerating around a corner 	<ul style="list-style-type: none"> Damaged or worn outboard CV joint. 	<ul style="list-style-type: none"> INSPECT the outboard CV joint and boot. REPAIR or INSTALL a new CV joint as necessary. REFER to Section 205-04.
<ul style="list-style-type: none"> High pitched chattering—noise from the rear axle when the vehicle is turning 	<ul style="list-style-type: none"> Incorrect or contaminated lubricant. Damaged or worn differential (differential side gears and pinion gears). 	<ul style="list-style-type: none"> CHECK the vehicle by driving in tight circles (5 clockwise, 5 counterclockwise). FLUSH and REFILL with the specified rear axle lubricant and friction modifier as necessary. DISASSEMBLE the differential assembly. INSPECT the differential case, pin and gears for wear or damage. REPAIR or INSTALL a new differential as necessary. REFER to Section 205-02A for Ford 8.8 rear axles, Section 205-02B for Ford 9.75 rear axles, Section 205-02C for Ford 10.25 rear axles or Section 205-03 for front axles.



BUY IT NOW!

Click Here To Order



DIAGNOSIS AND TESTING (Continued)**Symptom Chart—Driveline Noise/Vibration (Continued)**

Condition	Possible Sources	Action
<ul style="list-style-type: none"> Buzz—buzzing noise is the same at cruise or coast/deceleration 	<ul style="list-style-type: none"> Damaged or worn tires. Incorrect driveline angles. 	<ul style="list-style-type: none"> CHECK for abnormal tire wear or damage. INSTALL new tire(s) as necessary. REFER to Section 204-04. CHECK for correct driveline angles. REPAIR as necessary. REFER to Section 205-00.
<ul style="list-style-type: none"> Rumble or boom—noise occurs at coast/deceleration, usually driveshaft speed related and noticeable over a wide range of speeds 	<ul style="list-style-type: none"> Driveshaft is out-of-balance. U-joints binding or seized. Excessive pinion flange runout. 	<ul style="list-style-type: none"> CHECK the driveshaft for damage, missing balance weights or undercoating. CHECK the driveshaft balance. CARRY OUT a driveline vibration test. REFER to Section 205-00. ROTATE the driveshaft and CHECK for rough operation or seized U-joints. INSTALL new U-joints as necessary. REFER to Section 205-01. CARRY OUT a runout check. REPAIR as necessary. REFER to Section 205-00.
<ul style="list-style-type: none"> Grunting—normally associated with a shudder experienced during acceleration from a dead stop 	<ul style="list-style-type: none"> Driveshaft slip yoke binding. Loose rear spring U-bolts. 	<ul style="list-style-type: none"> CLEAN and LUBRICATE the male and female splines. INSPECT the rear suspension. TIGHTEN the U-bolt nuts to specification. REFER to Section 204-02.
<ul style="list-style-type: none"> Howl—can occur at various speeds and driving conditions. Affected by acceleration and deceleration 	<ul style="list-style-type: none"> Incorrect ring and pinion contact, incorrect bearing preload or gear damage. 	<ul style="list-style-type: none"> CHECK the ring and pinion and bearings for damage. INSPECT the ring and pinion wear pattern. REFER to Checking Tooth Contact Pattern and Condition of the Ring and Pinion component test in this section. ADJUST or INSTALL new components as necessary. REFER to Section 205-02A for Ford 8.8 rear axles, Section 205-02B for Ford 9.75 rear axles, Section 205-02C for Ford 10.25 rear axles or Section 205-03 for front axles.



BUY IT NOW!

Click Here To Order



DIAGNOSIS AND TESTING (Continued)**Symptom Chart—Driveline Noise/Vibration (Continued)**

Condition	Possible Sources	Action
<ul style="list-style-type: none"> • Chuckle—heard at coast/deceleration. Also described as a knock 	<ul style="list-style-type: none"> • Incorrect ring and pinion contact or by damaged teeth on the coast side of the ring and pinion. 	<ul style="list-style-type: none"> • CHECK the ring and pinion for damage. INSPECT the ring and pinion wear pattern. REFER to Checking Tooth Contact Pattern and Condition of the Ring and Pinion component test in this section. ADJUST or INSTALL new components as necessary. REFER to Section 205-02A for Ford 8.8 rear axles, Section 205-02B for Ford 9.75 rear axles Section 205-02C for Ford 10.25 rear axles or Section 205-03 for front axles.
<ul style="list-style-type: none"> • Knock—noise occurs at various speeds. Not affected by acceleration or deceleration 	<ul style="list-style-type: none"> • Gear tooth damage to the drive side of the ring and pinion. • Excessive axle shaft end play. (Vehicles with integral axles). 	<ul style="list-style-type: none"> • CHECK the differential case and ring and pinion for damage. INSTALL new components as necessary. REFER to Section 205-02A for Ford 8.8 rear axles, Section 205-02B for Ford 9.75 rear axles, Section 205-02C for Ford 10.25 rear axles or Section 205-03 for front axles. • CHECK the axle end play using a dial indicator. INSTALL a new axle shaft or side gears as necessary. REFER to Section 205-02A for Ford 8.8 rear axles, Section 205-02B for Ford 9.75 rear axles, Section 205-02C for Ford 10.25 rear axles or Section 205-03 for front axles.
<ul style="list-style-type: none"> • Scraping noise—a continuous low pitched noise starting at low speeds 	<ul style="list-style-type: none"> • Worn or damaged pinion bearings. 	<ul style="list-style-type: none"> • CHECK the pinion bearings. INSTALL new pinion bearings as necessary. REFER to Section 205-02A for Ford 8.8 rear axles, Section 205-02B for Ford 9.75 rear axles, Section 205-02C for Ford 10.25 rear axles or Section 205-03 for front axles.



BUY IT NOW!

Click Here To Order



DIAGNOSIS AND TESTING (Continued)**Symptom Chart—Driveline Noise/Vibration (Continued)**

Condition	Possible Sources	Action
<ul style="list-style-type: none"> • Driveline shudder—occurs during acceleration from a slow speed or stop 	<ul style="list-style-type: none"> • Rear drive axle assembly mispositioned. • Loose rear spring U-bolts. • Incorrect or high CV joint operating angle. • Damaged or worn front suspension components. • Driveline angles out of specification. • U-joints binding or seized. • Binding, damaged or galled splines on the driveshaft slip-yoke. 	<ul style="list-style-type: none"> • CHECK the axle mounts and the rear suspension for damage or wear. REPAIR as necessary. • INSPECT the U-bolts. TIGHTEN the U-bolt nuts to specification. REFER to Section 204-02. • CHECK vehicle ride height is within limits. REPAIR as necessary. • CHECK for a loose stabilizer bar, damaged or loose strut/strut bushings or loose or worn ball joints. INSPECT the steering linkage for wear or damage. REPAIR or INSTALL new components as necessary. • CHECK for correct driveline angles. REPAIR as necessary. REFER to Section 205-00. • ROTATE the driveshaft and CHECK for rough operation or seized U-joints. INSTALL new U-joints as necessary. REFER to Section 205-01. • CLEAN and INSPECT the splines of the slip-yoke, driveshaft and coupling shaft for a worn, damaged or galled condition. INSTALL a new slip-yoke or driveshaft assembly as necessary. REPAIR as necessary. REFER to Section 205-01.



BUY IT NOW!

Click Here To Order

PayPal



DIAGNOSIS AND TESTING (Continued)**Symptom Chart—Driveline Noise/Vibration (Continued)**

Condition	Possible Sources	Action
<ul style="list-style-type: none"> • Driveline vibration—occurs at cruising speeds 	<ul style="list-style-type: none"> • U-joints are worn. • Worn or damaged driveshaft center bearing support. • Loose axle pinion flange bolts. • Excessive axle pinion flange runout. • Driveshaft is out-of-balance. • Binding or damaged splines on the driveshaft slip-yoke. • Driveshaft runout. • Incorrect lateral and radial tire/wheel runout. • Driveline angles out of specification. • Incorrectly seated CV joint in the front wheel hub. 	<ul style="list-style-type: none"> • CHECK for wear or incorrect seating. INSTALL new U-joints as necessary. REFER to Section 205-01. • CHECK the insulator for damage or wear. ROTATE the driveshaft and CHECK for rough operation. INSTALL a new center bearing support as necessary. REFER to Section 205-01. • INSPECT the axle pinion flange. TIGHTEN the pinion flange bolts to specification. REFER to Section 205-01. • CARRY OUT a Runout Check. REPAIR as necessary. REFER to Section 205-01. • CHECK the driveshaft for damage, missing balance weights or undercoating. CHECK driveshaft balance. CARRY OUT a driveline vibration test. REFER to Section 205-00. REPAIR as necessary. • CLEAN and INSPECT the splines of the slip-yoke, driveshaft and coupling shaft for wear or damage. INSTALL a new slip-yoke or driveshaft assembly as necessary. REFER to Section 205-01. REPAIR as necessary. • CARRY OUT a Runout Check. REFER to Section 205-00. REPAIR as necessary. • INSPECT the tire and wheels. MEASURE tire runouts. REPAIR or INSTALL new components as necessary. REFER to Section 204-04. • CHECK for correct driveline angles. REPAIR as necessary. REFER to Section 205-00. • CHECK the outer CV joint for correct seating into the hub. REPAIR as necessary. REFER to Section 205-04.



BUY IT NOW!

Click Here To Order



DIAGNOSIS AND TESTING (Continued)**Symptom Chart — Engine Noise/Vibration**

Condition	Possible Sources	Action
<ul style="list-style-type: none"> Grinding noise—occurs during engine cranking 	<ul style="list-style-type: none"> Incorrect starter motor mounting. Starter motor. Incorrect starter motor drive engagement. 	<ul style="list-style-type: none"> INSPECT the starter motor for correct mounting. REPAIR as necessary. REFER to Section 303-06. CHECK the starter motor. REPAIR or INSTALL a new starter motor as necessary. REFER to Section 303-06. INSPECT the starter motor drive and flexplate/flywheel for wear or damage. INSTALL a new starter motor drive or flexplate/flywheel as necessary. REFER to Section 303-06.
<ul style="list-style-type: none"> Engine ticking noise 	<ul style="list-style-type: none"> Fuel injector. Fuel line. Oil pump. Valve lifter. Belt tensioner. Water pump. Obstruction of cooling fan. 	<ul style="list-style-type: none"> GO to Pinpoint Test B.
<ul style="list-style-type: none"> Engine drumming noise—normally accompanied by vibration 	<ul style="list-style-type: none"> Powertrain mount. Damaged or misaligned exhaust system. 	<ul style="list-style-type: none"> CARRY OUT Powertrain/Drivetrain Mount Neutralizing in this section. INSPECT the exhaust system for loose or broken clamps and brackets. CARRY OUT Exhaust System Neutralizing in this section.
<ul style="list-style-type: none"> Whistling noise—normally accompanied with poor idle condition 	<ul style="list-style-type: none"> Air intake system. 	<ul style="list-style-type: none"> CHECK the air intake ducts, air cleaner, throttle body and vacuum hoses for leaks and correct fit. REPAIR or ADJUST as necessary. REFER to Section 303-12.
<ul style="list-style-type: none"> Clunking noise 	<ul style="list-style-type: none"> Water pump has excessive end play or imbalance. Generator has excessive end play. 	<ul style="list-style-type: none"> CHECK the water pump for excessive end play. INSPECT the water pump with the drive belt off for imbalance. INSTALL a new water pump as necessary. REFER to Section 303-03A for standard cooling or Section 303-03B for supercharger cooling. CHECK the generator for excessive end play. REPAIR or INSTALL a new generator. REFER to Section 414-02.



BUY IT NOW!

Click Here To Order



DIAGNOSIS AND TESTING (Continued)**Symptom Chart — Engine Noise/Vibration (Continued)**

Condition	Possible Sources	Action
<ul style="list-style-type: none"> Pinging noise 	<ul style="list-style-type: none"> Exhaust system leak. Gasoline octane too low. Knock sensor operation. Incorrect spark timing. High operating temperature. Foul-out spark plug. Catalytic converter. 	<ul style="list-style-type: none"> INSPECT the exhaust system for leaks. REPAIR as necessary. VERIFY with customer the type of gasoline used. CORRECT as necessary. CHECK the knock sensor. INSTALL a new knock sensor as necessary. REFER to Section 303-14. CHECK the spark timing. REPAIR as necessary. INSPECT cooling system for leaks. CHECK the coolant level. REFILL as necessary. CHECK the coolant for the correct mix ratio. DRAIN and REFILL as needed. CHECK engine operating temperature is within specifications. REPAIR as necessary. CHECK the spark plugs. REPAIR or INSTALL new spark plugs as necessary. Acceptable noise.
<ul style="list-style-type: none"> Knocking noise—light knocking noise, also described as piston slap. Noise is most noticeable when engine is cold with light to medium acceleration. Noise disappears as engine warms 	<ul style="list-style-type: none"> Excessive clearance between the piston and the cylinder wall. 	<ul style="list-style-type: none"> Engine cold and at high idle. Using an EngineEAR, pull a spark plug or fuel injector connector until the noise goes away. CARRY OUT a cylinder bore clearance to piston check. INSTALL a new piston. REFER to Section 303-01A for 4.2L engines or Section 303-01B for 4.6L and 5.4L engines.
<ul style="list-style-type: none"> Knocking noise—light double knock or sharp rap sound. Occurs mostly with warm engine at idle or low speeds in DRIVE. Increases in relation to engine load. Associated with poor lubrication history 	<ul style="list-style-type: none"> Excessive clearance between the piston and the piston pin. 	<ul style="list-style-type: none"> INSTALL a new piston or piston pin. REFER to Section 303-01A for 4.2L engines or Section 303-01B for 4.6L and 5.4L engines.
<ul style="list-style-type: none"> Knocking noise—light knocking noise is most noticeable when engine is warm. Noise tends to decrease when vehicle is coasting or in neutral 	<ul style="list-style-type: none"> Excessive clearance between the connecting rod bearings and the crankshaft. 	<ul style="list-style-type: none"> Engine warm and at idle. Using an EngineEAR, PULL a spark plug or fuel injector connector until the noise goes away. INSTALL new bearings. REFER to Section 303-01A for 4.2L engines or Section 303-01B for 4.6L and 5.4L engines.



BUY IT NOW!

Click Here To Order



DIAGNOSIS AND TESTING (Continued)**Symptom Chart — Engine Noise/Vibration (Continued)**

Condition	Possible Sources	Action
<ul style="list-style-type: none"> Knocking—deep knocking noise. Noise is most noticeable when engine is warm, at lower rpm and under a light load and then at float 	<ul style="list-style-type: none"> Worn or damaged crankshaft main bearings. 	<ul style="list-style-type: none"> CARRY OUT Drive Engine Run-Up (DERU) Test. CHECK for noise with vehicle at operating temperature, during medium to heavy acceleration. CHECK at idle with injector disconnected, noise does not change. INSTALL new main bearings. REFER to Section 303-01A for 4.2L engines or Section 303-01B for 4.6L and 5.4L engines.
<ul style="list-style-type: none"> Knocking noise—occurs mostly with warm engine at light/medium acceleration 	<ul style="list-style-type: none"> Spark plugs. Carbon accumulation in combustion chamber. 	<ul style="list-style-type: none"> CHECK the spark plugs for damage or wear. INSTALL new spark plugs as necessary. REMOVE carbon from combustion chamber.
<ul style="list-style-type: none"> Whine or moaning noise 	<ul style="list-style-type: none"> Air intake system. Generator electrical field or bearings. 	<ul style="list-style-type: none"> CHECK the air cleaner and ducts for correct fit. INSPECT the air intake system for leaks or damage. REPAIR as necessary. CARRY OUT generator load test. REPAIR or INSTALL a new generator as necessary. REFER to Section 414-02.
<ul style="list-style-type: none"> Drone type noise 	<ul style="list-style-type: none"> Exhaust system. A/C compressor. Powertrain mounts. 	<ul style="list-style-type: none"> CARRY OUT the Exhaust System Neutralizing in this section. REPAIR as necessary. CHECK for noise with vehicle at constant speeds. CYCLE the compressor on and off and listen for a change in pitch. REPAIR as necessary. REFER to Section 412-03. CARRY OUT the Powertrain/Drivetrain Mount Neutralizing in this section.
<ul style="list-style-type: none"> Sputter type noise—noise worse when cold, lessens or disappears when vehicle is at operating temperature 	<ul style="list-style-type: none"> Damaged or worn exhaust system components. 	<ul style="list-style-type: none"> INSPECT the exhaust system for leaks or damage. REPAIR as necessary. REFER to Section 309-00.



BUY IT NOW!

Click Here To Order



DIAGNOSIS AND TESTING (Continued)**Symptom Chart — Engine Noise/Vibration (Continued)**

Condition	Possible Sources	Action
<ul style="list-style-type: none"> Rattling noise—noise from the upper engine (valve train). Worse when engine is cold 	<ul style="list-style-type: none"> Low oil level. Thin or diluted oil. Low oil pressure. Worn rocker arms/fulcrums or followers. Worn valve guides. Excessive runout of valve seats on the valve face. 	<ul style="list-style-type: none"> CHECK oil level. FILL as necessary. INSPECT the oil for contamination. If oil is contaminated, CHECK for the source. REPAIR as necessary. CHANGE the oil and filter. CARRY OUT an oil pressure test. If not within specifications, REPAIR as necessary. REFER to Section 303-01A for 4.2L engines or Section 303-01B for 4.6L and 5.4L engine. CARRY OUT a valve train analysis. INSTALL new valve train components as necessary. REFER to Section 303-01A for 4.2L engines or Section 303-01B for 4.6L and 5.4L engines. CARRY OUT a valve train analysis. INSTALL new valve guides as necessary. REFER to Section 303-01A for 4.2L engines or Section 303-01B for 4.6L and 5.4L engines. CARRY OUT a valve seat runout test. INSPECT the valve face and seat. INSTALL new valves as necessary. REFER to Section 303-01A for 4.2L engines or Section 303-01B for 4.6L and 5.4L engines.
<ul style="list-style-type: none"> Rattling noise—from the bottom of the vehicle 	<ul style="list-style-type: none"> Loose muffler shields or catalytic converter shields. 	<ul style="list-style-type: none"> CHECK the exhaust system for loose shields. REPAIR as necessary.
<ul style="list-style-type: none"> Thumping noise—from the bottom of the vehicle, worse at acceleration 	<ul style="list-style-type: none"> Exhaust pipe/muffler grounded to chassis. 	<ul style="list-style-type: none"> CHECK the exhaust system to chassis clearance. CHECK the exhaust system hangers for damage. REPAIR as necessary. REFER to Section 309-00.
<ul style="list-style-type: none"> Whoosh—occurs during light vehicle acceleration. Heard inside the vehicle 	<ul style="list-style-type: none"> Throttling late, creating turbulence transmitted through the plastic manifold. 	<ul style="list-style-type: none"> CHECK for leaks or missing seal in the dash panel.



BUY IT NOW!

Click Here To Order



DIAGNOSIS AND TESTING (Continued)**Symptom Chart — Engine Noise/Vibration (Continued)**

Condition	Possible Sources	Action
<ul style="list-style-type: none"> Engine vibration—increases intensity as engine rpm is increased 	<ul style="list-style-type: none"> Engine out-of-balance. 	<ul style="list-style-type: none"> CARRY OUT Neutral Engine Run-Up (NERU) Test. ROTATE the torque converter, 120° for 3 bolt and 180° for 4 bolt. INSPECT the torque converter pilot outer diameter to crankshaft pilot inner diameter. REPAIR as necessary. REFER to Section 307-01A for 4R100 transmissions. REFER to Section 307-01B for 4R70W transmissions.
<ul style="list-style-type: none"> Engine vibration—is felt with increases and decreases in engine rpm 	<ul style="list-style-type: none"> Strain on exhaust mounts. Damaged or worn powertrain/drivetrain mounts. Engine or transmission grounded to chassis. 	<ul style="list-style-type: none"> CARRY OUT the Exhaust System Neutralizing in this section. REPAIR as necessary. CHECK the powertrain/drivetrain mounts for damage. REFER to Section 303-01A for 4.2L engines or Section 303-01B for 4.6L and 5.4L engines. REPAIR as necessary. INSPECT the powertrain/drivetrain for correct clearances. REPAIR as necessary.
<ul style="list-style-type: none"> Engine vibration—vibration felt at all times 	<ul style="list-style-type: none"> Excessive engine pulley runout. Damaged or worn accessory component. 	<ul style="list-style-type: none"> CARRY OUT Engine Accessory Test. INSTALL a new engine pulley as necessary. REFER to Section 303-01A for 4.2L engines or Section 303-01B for 4.6L and 5.4L engines. CARRY OUT Engine Accessory Test. REPAIR or INSTALL a new component as necessary.
<ul style="list-style-type: none"> Accelerator pedal vibration—felt through the pedal as a buzz 	<ul style="list-style-type: none"> Throttle cable loose or misrouted. 	<ul style="list-style-type: none"> INSPECT the throttle cable. REPAIR as necessary. REFER to Section 310-02.
<ul style="list-style-type: none"> Engine vibration—mostly at coast/neutral coast. Condition improves with vehicle accelerating 	<ul style="list-style-type: none"> Combustion instability. 	<ul style="list-style-type: none"> CHECK the ignition system. INSTALL new components as necessary.



BUY IT NOW!

Click Here To Order

PayPal

MasterCard

DISCOVER
NEWUS

MasterCard

VISA

DIAGNOSIS AND TESTING (Continued)**Symptom Chart — Engine Noise/Vibration (Continued)**

Condition	Possible Sources	Action
<ul style="list-style-type: none"> Engine vibration or shudder—occurs with light to medium acceleration above 56 km/h (35 mph) 	<ul style="list-style-type: none"> Worn or damaged spark plugs. Plugged fuel injector. Damaged spark plug wire. Contaminated fuel. Worn or damaged torque converter. 	<ul style="list-style-type: none"> INSPECT the spark plugs for cracks, high resistance or broken insulator. INSTALL a new spark plug(s) as necessary. REPAIR or INSTALL a new injector as necessary. INSPECT the spark plug wires for damage. INSTALL a new spark plug wire(s) as necessary. INSPECT the fuel for contamination. DRAIN the fuel system and refill. CHECK the torque converter. INSTALL a new torque converter as necessary. REFER to Section 307-01B for 4R70W transmissions. REFER to Section 307-01A for 4R100 transmissions.

Symptom Chart—Idle Noise/Vibration

Condition	Possible Sources	Action
<ul style="list-style-type: none"> Idle air control (IAC) valve moan — occurs on throttle tip-out 	<ul style="list-style-type: none"> IAC valve is contaminated with oil. 	<ul style="list-style-type: none"> GO to Component Tests in this section.
<ul style="list-style-type: none"> Accessory drive belt chirp — occurs at idle or high idle, cold or hot. Most common occurrence is during humid weather 	<ul style="list-style-type: none"> Accessory drive belt worn, or pulley is misaligned or loose. 	<ul style="list-style-type: none"> INSPECT for loose or misaligned pulleys. CHECK the drive belt for wear or damage. INSTALL new pulley(s)/accessory drive components or drive belt, as necessary. REFER to Section 303-05.
<ul style="list-style-type: none"> Accessory drive bearing hoot — occurs at idle or high idle in cold temperatures of approximately +4°C (+40°F) or colder at first start of the day 	<ul style="list-style-type: none"> Accessory drive idler or tensioner pulley bearing is experiencing stick/slip between ball bearings and bearing race. 	<ul style="list-style-type: none"> GO to Pinpoint Test C.
<ul style="list-style-type: none"> Power steering moan — occurs at high idle and possibly at idle during the first cold start of the day in temperatures of approximately -18°C (0°F) or colder. Noise can even be a severe screech for less than one minute in very cold temperatures of approximately -29°C (-20°F) or colder 	<ul style="list-style-type: none"> High fluid viscosity, or plugged reservoir screen in power steering reservoir starves pump causing cavitation. 	<ul style="list-style-type: none"> GO to Pinpoint Test D.



BUY IT NOW!
Click Here To Order



DIAGNOSIS AND TESTING (Continued)**Symptom Chart—Idle Noise/Vibration (Continued)**

Condition	Possible Sources	Action
<ul style="list-style-type: none"> Generator whine — during high electrical loads at idle or high idle, a high pitch whine or moan is emitted from the generator 	<ul style="list-style-type: none"> Generator electrical field noise. 	<ul style="list-style-type: none"> Using an EngineEAR, PROBE near the generator housing. LISTEN for changes in the noise level while changing electrical loads (such as rear defrost, headlamps, etc.). CARRY OUT a generator load test. If the system passes the load test, the noise is from the generator bearings. INSTALL new bearings. If the system fails the load test, INSTALL a new generator. REFER to Section 414-02.
<ul style="list-style-type: none"> Engine-driven cooling fan moan — occurs during the first start of the day. It is most objectionable near idle speeds up to 2000 rpm. The noise increases with rpm 	<ul style="list-style-type: none"> The viscous cooling fan clutch engages until the fluid in the clutch reaches normal operating temperature, causing the fan to fully engage. 	<ul style="list-style-type: none"> GO to Pinpoint Test E.
<ul style="list-style-type: none"> Drumming noise — occurs inside the vehicle during idle or high idle, hot or cold. Very low-frequency drumming is very rpm dependent 	<ul style="list-style-type: none"> Exhaust system vibration excites the body resonances inducing interior noise. Engine vibration excites the body resonances inducing interior noise. 	<ul style="list-style-type: none"> GO to Pinpoint Test F.
<ul style="list-style-type: none"> Hissing noise — occurs during idle or high idle that is apparent with the hood open 	<ul style="list-style-type: none"> Vacuum leak or idle air control (IAC) valve flow noise. Vehicles with a plastic intake manifold. 	<ul style="list-style-type: none"> Use the Ultrasonic Leak Detector/EngineEAR to locate the source. Scan the air intake system from the inlet to each cylinder intake port. DISCARD the leaking parts, and INSTALL a new component. Acceptable condition. Some plastic manifolds exhibit this noise, which is the effect of the plastic manifold.
<ul style="list-style-type: none"> Automatic transmission buzz or hiss 	<ul style="list-style-type: none"> Incorrect driveline angles. Worn or damaged main control solenoids or valves. 	<ul style="list-style-type: none"> CHECK for correct driveline angles. REPAIR as necessary. REFER to Section 205-00. Using a transmission tester, activate the solenoids to duplicate sound. INSTALL new components as necessary. REFER to Section 307-01B for 4R70W transmissions. REFER to Section 307-01A for 4R100 transmissions.
<ul style="list-style-type: none"> Manual Transmission Clutch throw-out bearing whine. A change in noise pitch or 	<ul style="list-style-type: none"> Worn throw-out bearing. 	<ul style="list-style-type: none"> INSTALL a new throw-out bearing. REFER to Section 308-01.



BUY IT NOW!

Click Here To Order



DIAGNOSIS AND TESTING (Continued)**Symptom Chart—Idle Noise/Vibration (Continued)**

Condition	Possible Sources	Action
<ul style="list-style-type: none"> • Heating, vacuum and air conditioning (HVAC) system chirp — most audible inside the vehicle. Listen for a change in noise pitch or loudness while changing the HVAC system blower speed 	<ul style="list-style-type: none"> • Damaged or worn HVAC blower bearing. 	<ul style="list-style-type: none"> • INSTALL a new blower motor. REFER to Section 412-02.
<ul style="list-style-type: none"> • Air conditioning (A/C) clutch ticking — occurs when the compressor clutch engages 	<ul style="list-style-type: none"> • Acceptable noise. • Incorrect air gap. 	<ul style="list-style-type: none"> • LISTEN to the clutch to determine if the noise occurs with clutch engagement. A small amount of noise is acceptable. If the noise is excessive, CHECK the A/C clutch air gap. INSPECT the A/C clutch for wear or damage. INSTALL a new clutch as necessary. REFER to Section 412-03.
<ul style="list-style-type: none"> • Intermittent rattle, or scraping/rubbing noise 	<ul style="list-style-type: none"> • Loose exhaust heat shield(s). • Wiring, hose or other part interfering with accessory drive, drive belt or pulley. 	<ul style="list-style-type: none"> • INSPECT the exhaust system for loose parts using a glove or clamps to verify cause. REPAIR as necessary. REFER to Section 309-00. • INSPECT accessory drive system closely verifying there is adequate clearance to all rotating components. REPAIR as necessary.
<ul style="list-style-type: none"> • Engine ticking or knocking noise — occurs during idle or high idle during the first cold start of the day 	<ul style="list-style-type: none"> • Piston noise or valvetrain noise (bled down lifter/lash adjuster). 	<ul style="list-style-type: none"> • GO to Pinpoint Test G.
<ul style="list-style-type: none"> • A continuous, speed-dependent rattle from the engine — occurs during idle or high idle during the first cold start of the day and disappears as the engine warms up 	<ul style="list-style-type: none"> • Piston noise or valvetrain noise (bled down lifter/lash adjuster). 	<ul style="list-style-type: none"> • GO to Pinpoint Test G.
<ul style="list-style-type: none"> • Idle vibration—a low-frequency vibration (5-20 Hz) or mild shake that is felt through the seat/floorpan 	<ul style="list-style-type: none"> • Cylinder misfire. • Engine or torque converter out of balance. 	<ul style="list-style-type: none"> • Using a scan tool, CHECK the ignition system. CARRY OUT a cylinder power test. REFER to Section 303-00. • VERIFY the torque converter to crankshaft pilot clearance is correct, REPAIR as necessary. RE-INDEX the torque converter on the flex plate by 120° on a 3 bolt converter or 180° for a 4 bolt converter. REFER to Section 307-01B for 4R70W transmissions. REFER to Section 307-01A for 4R100 transmissions. RETEST the vehicle.



BUY IT NOW!

Click Here To Order



DIAGNOSIS AND TESTING (Continued)**Symptom Chart—Idle Noise/Vibration (Continued)**

Condition	Possible Sources	Action
<ul style="list-style-type: none"> Idle vibration—a high-frequency vibration (20-80 Hz) or buzz, that is felt through the steering wheel or seat 	<ul style="list-style-type: none"> Exhaust system mounts bound up. Body mounts loose. Power steering lines grounded out. 	<ul style="list-style-type: none"> VERIFY concern occurs at engine firing frequency. CHECK that the exhaust system vibrates at the same frequency as the engine. ADD 9-14 km (20-30 lb.) to the tail pipe to test. CARRY OUT Exhaust System Neutralizing in this section. INSPECT the body mounts. REPAIR as necessary. INSPECT that the power steering lines are not contacting the chassis or each other. REPAIR as necessary.

Symptom Chart—Squeak and Rattle

Condition	Possible Sources	Action
<ul style="list-style-type: none"> Squeak—heard inside the vehicle when closing/opening the door 	<ul style="list-style-type: none"> Insufficient lubrication on the door hinge or check strap. Internal door components loose, rubbing or misaligned. 	<ul style="list-style-type: none"> LUBRICATE the hinge or check strap. CHECK the inside of the door. TIGHTEN or ALIGN as necessary. USE the Squeak and Rattle Repair Kit to isolate any rubbing components.
<ul style="list-style-type: none"> Squeak—heard inside the vehicle when closing/opening the window 	<ul style="list-style-type: none"> Worn or damaged glass run/channel. 	<ul style="list-style-type: none"> REPAIR or INSTALL a new glass run/channel. REFER to Section 501-11.
<ul style="list-style-type: none"> Squeak—heard outside of vehicle when closing/opening the door 	<ul style="list-style-type: none"> Exhaust shield rubbing against the chassis or exhaust pipe. 	<ul style="list-style-type: none"> CHECK the exhaust system. REPAIR as necessary. Section 309-00.
<ul style="list-style-type: none"> Squeak—occurs with initial brake pedal application 	<ul style="list-style-type: none"> Disc brake pads. 	<ul style="list-style-type: none"> Under certain conditions, asbestos free pads can generate a squeak noise. This noise is normal and does not indicate a concern.
<ul style="list-style-type: none"> Squeak—a constant noise that occurs with brake pedal applications 	<ul style="list-style-type: none"> Damaged or worn disc brake pads. 	<ul style="list-style-type: none"> INSPECT the pads for oil, grease or brake fluid contamination. CHECK for glazed linings. A brake disc with hard spots will also cause a squeak type noise. REPAIR or INSTALL new pads as necessary. REFER to Section 206-03 for front disc brakes or Section 206-04 for rear disc brakes.



BUY IT NOW!
Click Here To Order



DIAGNOSIS AND TESTING (Continued)**Symptom Chart—Squeak and Rattle (Continued)**

Condition	Possible Sources	Action
<ul style="list-style-type: none"> Squeak—noise occurs over bumps or when turning 	<ul style="list-style-type: none"> Worn control arm bushings. Worn or damaged shock absorber/strut. 	<ul style="list-style-type: none"> INSPECT the control arm bushings. Spray with lubricant and CARRY OUT a “bounce test” to determine which bushing. REPAIR as necessary. REFER to Section 204-01A for 2-wheel drive vehicles or Section 204-01B for 4-wheel drive vehicles. INSPECT the shock absorber for damage. CARRY OUT a “bounce test” to isolate the noise. INSTALL a new shock absorber/strut as necessary. REFER to Section 204-01A for 2-wheel drive vehicles and Section 204-01B for 4-wheel drive vehicles front shock absorber/strut or Section 204-02 for the rear shock absorber/strut.
<ul style="list-style-type: none"> Rattle—heard when closing/opening the door or window 	<ul style="list-style-type: none"> Loose internal door mechanism, bracket or attachment. 	<ul style="list-style-type: none"> REPEAT the motion or CARRY OUT a “tap test” to duplicate the noise. INSPECT the door for loose components. TIGHTEN loose components or USE the Rotunda Squeak and Rattle Kit to isolate any rattling components.
<ul style="list-style-type: none"> Squeak or rattle—heard inside the vehicle over rough roads/bumps 	<ul style="list-style-type: none"> Misaligned glove compartment door/hinge. Instrument panel trim loose or misaligned. Loose interior component or trim. 	<ul style="list-style-type: none"> ALIGN the glove compartment door. INSPECT the instrument panel trim for missing or loose clips or screws. REPAIR as necessary. CARRY OUT a “touch test”. ELIMINATE the noise by pressing or pulling on interior trim and components. USE the Rotunda Squeak and Rattle Kit to isolate any rattling/squeaking components.



BUY IT NOW!

Click Here To Order



DIAGNOSIS AND TESTING (Continued)**Symptom Chart—Squeak and Rattle (Continued)**

Condition	Possible Sources	Action
<ul style="list-style-type: none"> Squeak or rattle—noise with a vibration concern 	<ul style="list-style-type: none"> Damaged or worn body mounts. Damaged or worn sub-frame mounts. 	<ul style="list-style-type: none"> INSPECT the upper and lower absorbers and washers for damage or wear. CHECK the body mount brackets for damage. CHECK the nuts and bolts are tightened to specifications. TIGHTEN as necessary. INSPECT the upper and lower absorbers for damage or wear. CHECK the sub-frame for damage. CHECK the nuts and bolts are tightened to specifications. TIGHTEN as necessary.

Symptom Chart—Steering Noise/Vibration

Condition	Possible Sources	Action
<ul style="list-style-type: none"> Steering grunt or shudder — occurs when turning into or out of a turn at low speeds (temperature sensitive) 	<ul style="list-style-type: none"> Steering gear or power steering hoses. 	<ul style="list-style-type: none"> GO to Steering Gear Grunt/Shudder Test component test in this section.
<ul style="list-style-type: none"> Steering System clonk—hydraulic knocking sound 	<ul style="list-style-type: none"> Air in the steering hydraulic system. 	<ul style="list-style-type: none"> CHECK for leaks in the system. PURGE the air from the system. REFER to Section 211-00.
<ul style="list-style-type: none"> Power steering pump moan — loud humming noise occurs when the steering wheel is rotated to the stop position. Produces a 120-600 Hz frequency that changes with rpm 	<ul style="list-style-type: none"> Power steering hose grounded out to chassis. Aerated fluid. Steering gear isolators. Low fluid. Power steering pump brackets loose or misaligned. 	<ul style="list-style-type: none"> INSPECT the power steering hoses. REPAIR as necessary. CHECK for leaks in the system. PURGE the air from the system. REFER to Section 211-00. INSPECT the isolators for wear or damage. REPAIR as necessary. CHECK the fluid level. REFILL as necessary. CHECK bolts, brackets and bracket alignment. TIGHTEN bolts to specification. REPAIR or INSTALL new brackets as necessary. REFER to Section 211-02.
<ul style="list-style-type: none"> Steering gear clunk — occurs only while cornering over a bump (can be temperature sensitive) 	<ul style="list-style-type: none"> Steering gear. 	<ul style="list-style-type: none"> INSPECT the steering gear for loose mounting bolts. TIGHTEN as necessary. REFER to Section 211-02.

**BUY IT NOW!****Click Here To Order**

DIAGNOSIS AND TESTING (Continued)**Symptom Chart—Steering Noise/Vibration (Continued)**

Condition	Possible Sources	Action
<ul style="list-style-type: none"> Feedback (rattle, chuckle or knocking noise in the steering gear) — a condition where roughness is felt in the steering wheel when the vehicle is driven over rough surfaces 	<ul style="list-style-type: none"> Column intermediate/flexible shaft joints damaged or worn. Loose, damaged or worn tie-rod ends. Steering gear insulators or mounting bolts loose or damaged. Steering column intermediate shaft bolts are loose. Steering column damaged or worn. Loose suspension bushings, bolts or ball joints. 	<ul style="list-style-type: none"> INSTALL a new intermediate/flexible shaft. REFER to Section 211-04. TIGHTEN the nuts to specification or INSTALL new tie-rod ends as necessary. REFER to Section 211-03. TIGHTEN the bolts or INSTALL new bolts as necessary. REFER to Section 211-02. TIGHTEN the bolts to specification. REFER to Section 211-04. REPAIR or INSTALL a new steering column as necessary. REFER to Section 211-04. INSPECT the suspension system. TIGHTEN or INSTALL new components as necessary. REFER to Section 204-01A for 2-wheel drive vehicles or Section 204-01B for 4-wheel drive vehicles.
<ul style="list-style-type: none"> Feedback (nibble at the steering wheel) — a condition where slight rotational movement is felt in the steering wheel when the vehicle is driven over rough or grooved surfaces 	<ul style="list-style-type: none"> Lateral runout in the tire or wheel. Yoke spring in the steering gear. 	<ul style="list-style-type: none"> GO to Pinpoint Test H. CHECK TSBs for revised yoke spring for applicable vehicles.
<ul style="list-style-type: none"> Accessory drive belt squeal/chirp—when rotating the steering wheel from stop to stop 	<ul style="list-style-type: none"> Loose or worn accessory drive belt. 	<ul style="list-style-type: none"> ADJUST or INSTALL a new accessory belt as necessary. REFER to Section 303-05.
<ul style="list-style-type: none"> Power steering gear hiss 	<ul style="list-style-type: none"> Steering column intermediate/flexible shaft-to-steering gear is binding or misaligned. Grounded or loose steering column boot at the dash panel. Damaged or worn steering gear input shaft and valve. 	<ul style="list-style-type: none"> REPAIR or INSTALL a new intermediate/flexible shaft as necessary. REFER to Section 211-04. REPAIR as necessary. REPAIR or INSTALL a new steering gear as necessary. REFER to Section 211-02.



BUY IT NOW!

Click Here To Order



DIAGNOSIS AND TESTING (Continued)**Symptom Chart—Steering Noise/Vibration (Continued)**

Condition	Possible Sources	Action
<ul style="list-style-type: none"> Steering column rattle 	<ul style="list-style-type: none"> Loose bolts or attaching brackets. Loose, worn or insufficiently lubricated column bearings. Steering shaft insulators damaged or worn. Intermediate/flexible shaft compressed or extended. 	<ul style="list-style-type: none"> TIGHTEN the bolts to specifications. LUBRICATE or INSTALL new steering column bearings as necessary. REFER to Section 211-04. INSTALL new insulators. REFER to Section 211-04. INSPECT the rubber spider coupling for damage. INSTALL a new intermediate/flexible shaft. REFER to Section 211-04.
<ul style="list-style-type: none"> Steering column squeak or cracks 	<ul style="list-style-type: none"> Insufficient lubricated steering shaft bushings. Loose or misaligned steering column shrouds. Steering wheel rubbing against steering column shrouds. Insufficient lubricated speed control slip ring. Upper or lower bearing sleeve out of position. 	<ul style="list-style-type: none"> LUBRICATE the steering shaft and shaft tube seals. TIGHTEN or ALIGN the steering column shrouds. REPOSITION the steering column shrouds. LUBRICATE the speed control slip ring. REPOSITION the bearing sleeves.
<ul style="list-style-type: none"> Power steering pump noisy 	<ul style="list-style-type: none"> Incorrect assembly of components. Imperfections on the outside diameter or end surface of the power steering pump rotor. Damaged or worn power steering pump rotor splines. A crack on the inner surface of the power steering pump cam. Interference between the power steering pump rotor and cam. Damaged or worn power steering pump rotor and pressure plates. 	<ul style="list-style-type: none"> REPAIR or INSTALL a new power steering pump as necessary. REFER to Section 211-02.
<ul style="list-style-type: none"> Power steering pump swish noise 	<ul style="list-style-type: none"> Power steering fluid flow into the bypass valve of the pump valve housing with fluid temperature below 54°C (130°F). 	<ul style="list-style-type: none"> Acceptable condition.
<ul style="list-style-type: none"> Power steering pump whine noise 	<ul style="list-style-type: none"> Aerated fluid. Damaged power steering pump cam. Damaged valve cover O-ring seal. 	<ul style="list-style-type: none"> CHECK for a leak in the system. PURGE the air from the system. REFER to Section 211-00. REPAIR or INSTALL a new power steering pump as necessary. REFER to Section 211-02. REPAIR or INSTALL a new power steering pump as necessary. REFER to Section 211-02.



BUY IT NOW!

Click Here To Order



DIAGNOSIS AND TESTING (Continued)**Symptom Chart—Steering Noise/Vibration (Continued)**

Condition	Possible Sources	Action
<ul style="list-style-type: none"> Power steering pump clicking (mechanical) noise 	<ul style="list-style-type: none"> Power steering pump rotor slippers too long, excessive rotor slipper-to-slot clearance or damaged or worn rotor assembly. 	<ul style="list-style-type: none"> REPAIR or INSTALL a new power steering pump as necessary. REFER to Section 211-02.
<ul style="list-style-type: none"> Power steering pump clatter noise 	<ul style="list-style-type: none"> Damaged corners on the outside diameter or the power steering rotor or distorted rotor slipper ring. 	<ul style="list-style-type: none"> REPAIR or INSTALL a new power steering pump as necessary. REFER to Section 211-02.

Symptom Chart—Suspension Noise/Vibration

Condition	Possible Sources	Action
<ul style="list-style-type: none"> Squeak or grunt—noise from the front suspension, occurs more in cold ambient temperatures. More noticeable over rough roads or when turning 	<ul style="list-style-type: none"> Front stabilizer bar insulators. 	<ul style="list-style-type: none"> Under these conditions, the noise is acceptable. CHECK TSBs for applicable vehicle.
<ul style="list-style-type: none"> Clunk—noise from the front suspension, occurs in and out of turns 	<ul style="list-style-type: none"> Loose front struts or shocks. 	<ul style="list-style-type: none"> INSPECT for loose nuts or bolts. TIGHTEN to specifications. REFER to Section 204-01A for 2-wheel drive vehicles or Section 204-01B for 4-wheel drive vehicles.
<ul style="list-style-type: none"> Clunk—noise from the rear suspension, occurs when shifting from reverse to drive 	<ul style="list-style-type: none"> Loose rear suspension components. 	<ul style="list-style-type: none"> INSPECT for loose or damaged rear suspension components. REPAIR or INSTALL new components as necessary. REFER to Section 204-02.
<ul style="list-style-type: none"> Click or pop—noise from the front suspension. More noticeable over rough roads or over bumps 	<ul style="list-style-type: none"> Worn or damaged ball joints. 	<ul style="list-style-type: none"> CARRY OUT a ball joint inspection. INSTALL new ball joints or control arms as necessary. REFER to Section 204-01A for 2-wheel drive vehicles or Section 204-01B for 4-wheel drive vehicles.
<ul style="list-style-type: none"> Click or pop (FWD vehicles)—noise occurs when vehicle is turning 	<ul style="list-style-type: none"> Worn or damaged ball joints. 	<ul style="list-style-type: none"> CARRY OUT a ball joint inspection. INSTALL new ball joints or control arms as necessary.
<ul style="list-style-type: none"> Click or snap—occurs when accelerating around a corner 	<ul style="list-style-type: none"> Damaged or worn outboard CV joint. 	<ul style="list-style-type: none"> INSPECT the outboard CV joint and boot. REPAIR or INSTALL a new CV joint as necessary. REFER to Section 204-01B.



BUY IT NOW!
Click Here To Order



DIAGNOSIS AND TESTING (Continued)**Symptom Chart—Suspension Noise/Vibration (Continued)**

Condition	Possible Sources	Action
<ul style="list-style-type: none"> Front suspension noise—a squeak, creak or rattle noise. Occurs mostly over bumps or rough roads 	<ul style="list-style-type: none"> Steering components. Loose or bent front struts or shock absorbers. Damaged spring or spring mounts. Damaged or worn control/radius arm bushings. Worn or damaged stabilizer bar bushings or links. 	<ul style="list-style-type: none"> GO to Pinpoint Test H.
<ul style="list-style-type: none"> Rear suspension noise—a squeak, creak or rattle noise. Occurs mostly over bumps or rough roads 	<ul style="list-style-type: none"> Loose or bent rear shock absorbers. Damaged spring or spring mounts. Damaged or worn control arm bushings. Worn or damaged stabilizer bar bushings or links. 	<ul style="list-style-type: none"> GO to Pinpoint Test I.
<ul style="list-style-type: none"> Shudder—occurs during acceleration from a slow speed or stop 	<ul style="list-style-type: none"> Rear drive axle assembly mispositioned. Incorrect or high CV joint operating angle. Damaged or worn front suspension components. 	<ul style="list-style-type: none"> CHECK the axle mounts and the rear suspension for damage or wear. REPAIR as necessary. CHECK vehicle ride height is within limits. REPAIR as necessary. CHECK for a loose stabilizer bar, damaged or loose strut/strut bushings or loose or worn ball joints. INSPECT the steering linkage for wear or damage. REPAIR or INSTALL new components as necessary.
<ul style="list-style-type: none"> Shimmy—most noticeable on coast/deceleration. Also hard steering condition 	<ul style="list-style-type: none"> Excessive positive caster. 	<ul style="list-style-type: none"> CHECK the caster alignment angle. CORRECT as necessary. REFER to Section 204-00.

Symptom Chart—Tire Noise/Vibration

Condition	Possible Sources	Action
<ul style="list-style-type: none"> Tire noise—hum/moan at constant speeds 	<ul style="list-style-type: none"> Abnormal wear patterns. 	<ul style="list-style-type: none"> SPIN the tire and CHECK for tire wear. INSTALL new tire(s) as necessary. INSPECT for damaged/worn suspension components. CARRY OUT wheel alignment.
<ul style="list-style-type: none"> Tire noise—noise tone lowers as the vehicle speed is lowered 	<ul style="list-style-type: none"> Out-of-balance tire. 	<ul style="list-style-type: none"> BALANCE the tire and road test. INSTALL a new tire as necessary. REFER to Section 204-04.
<ul style="list-style-type: none"> Tire noise — ticking noise, changes with speed 	<ul style="list-style-type: none"> Nail puncture or stone in tire tread. 	<ul style="list-style-type: none"> INSPECT the tire. REPAIR as necessary.
<ul style="list-style-type: none"> Wheel and tire—vibration and noise concern is directly related 	<ul style="list-style-type: none"> Damaged or worn tire. 	<ul style="list-style-type: none"> GO to Pinpoint Test J.



BUY IT NOW!

Click Here To Order



DIAGNOSIS AND TESTING (Continued)**Symptom Chart—Tire Noise/Vibration (Continued)**

Condition	Possible Sources	Action
<ul style="list-style-type: none"> Tire wobble or shudder — occurs at lower speeds 	<ul style="list-style-type: none"> Damaged wheel bearings. Damaged wheel. Damaged or worn suspension components. Loose wheel nuts. Damaged or uneven tire wear. 	<ul style="list-style-type: none"> SPIN the tire and CHECK for abnormal wheel bearing play or roughness. ADJUST or INSTALL new wheel bearings as necessary. REFER to Section 204-01A for 2-wheel drive vehicles or Section 204-01B for 4-wheel drive vehicles. INSPECT the wheel for damage. INSTALL a new wheel as necessary. REFER to Section 204-04. INSPECT the suspension components for wear or damage. REPAIR as necessary. CHECK the wheel nuts. TIGHTEN to specification. REFER to Section 204-04. SPIN the tire and CHECK for abnormal tire wear or damage. INSTALL a new tire as necessary. REFER to Section 204-04.
<ul style="list-style-type: none"> Tire shimmy or shake— occurs at lower speeds 	<ul style="list-style-type: none"> Wheel/tire out of balance. Uneven tire wear. Excessive radial runout of wheel or tire. Worn or damaged wheel studs or elongated stud holes. Excessive lateral runout of the wheel or tire. Foreign material between the brake disc and hub or in the brake disc fins. 	<ul style="list-style-type: none"> BALANCE the wheel/tire assembly. CHECK for abnormal tire wear. INSTALL a new tire as necessary. REFER to Section 204-04. CARRY OUT a radial runout test of the wheel and tire. INSTALL a new tire as necessary. REFER to Section 204-04. INSPECT the wheel studs and wheels. INSTALL new components as necessary. REFER to Section 204-01A for 2-wheel drive front wheels, Section 204-01B for 4-wheel drive front wheels and Section 204-02 for all rear wheels. CARRY OUT a lateral runout test of the wheel and tire. CHECK the wheel, tire and hub. REPAIR or INSTALL new components as necessary. CLEAN the mounting surfaces of the brake disc and hub. CHECK the brake disc fins for material.



BUY IT NOW!

Click Here To Order



DIAGNOSIS AND TESTING (Continued)**Symptom Chart—Tire Noise/Vibration (Continued)**

Condition	Possible Sources	Action
<ul style="list-style-type: none"> High speed shake or shimmy—occurs at high speeds 	<ul style="list-style-type: none"> Excessive wheel hub runout. Damaged or worn tires. Damaged or worn wheel bearings. Worn or damaged suspension or steering linkage components. Brake disc or drum imbalance. 	<ul style="list-style-type: none"> GO to Pinpoint Test K.

Symptom Chart—Transmission (Manual) and Transfer Case Noise/Vibration

Condition	Possible Sources	Action
<ul style="list-style-type: none"> Clutch rattling noise—occurs with clutch engaged, noise changes/disappears with clutch pedal depressed 	<ul style="list-style-type: none"> Flywheel bolts, clutch housing bolts or clutch pressure plate bolts loose. 	<ul style="list-style-type: none"> TIGHTEN the bolts to specifications. CHECK the bolts for damage.
<ul style="list-style-type: none"> Clutch squeaking noise—noise is heard when the clutch is operated. Vehicle moves slowly or creeps when the clutch is disengaged. Can also be difficult to shift into first and reverse gear 	<ul style="list-style-type: none"> Pilot bearing seized or damaged. 	<ul style="list-style-type: none"> INSTALL a new pilot bearing. REFER to Section 308-01.
<ul style="list-style-type: none"> Clutch squeaking noise—occurs with clutch pedal depressed/released 	<ul style="list-style-type: none"> Worn clutch pedal shaft or bushings. 	<ul style="list-style-type: none"> INSPECT the clutch pedal for wear or damage. REPAIR as necessary. REFER to Section 308-02.
<ul style="list-style-type: none"> Clutch whirring/rattle noise—occurs when clutch pedal is depressed 	<ul style="list-style-type: none"> Worn, damaged or misaligned clutch release bearing. 	<ul style="list-style-type: none"> INSTALL a new clutch release bearing. REFER to Section 308-01.
<ul style="list-style-type: none"> Clutch grating/grinding noise—occurs when clutch pedal is depressed 	<ul style="list-style-type: none"> Clutch pressure plate fingers bent or worn. Contact surface of clutch release bearing worn or damaged. 	<ul style="list-style-type: none"> INSPECT the clutch pressure plate release fingers. INSTALL a new pressure plate as necessary. REFER to Section 308-01. INSTALL a new clutch release bearing. REFER to Section 308-01.
<ul style="list-style-type: none"> Clutch chatter—a small amount of noise when clutch pedal is released at initial take-off 	<ul style="list-style-type: none"> Clutch engagement. 	<ul style="list-style-type: none"> Acceptable operating condition.



BUY IT NOW!
Click Here To Order



DIAGNOSIS AND TESTING (Continued)**Symptom Chart—Transmission (Manual) and Transfer Case Noise/Vibration (Continued)**

Condition	Possible Sources	Action
<ul style="list-style-type: none"> Clutch chatter/grabs—in some cases a shudder is felt. Occurs with clutch pedal depressed/released 	<ul style="list-style-type: none"> Damaged or worn powertrain/driveline mounts. Binding or dragging plunger of the clutch master cylinder or slave cylinder. Grease or oil on the clutch disc facing. Clutch disc surface glazed or damaged. Damaged or worn clutch pressure plate. Flywheel surface damaged or glazed. 	<ul style="list-style-type: none"> INSPECT the powertrain/drivetrain mounts. REFER to Section 303-01A for 4.2L engines or Section 303-01B for 4.6L and 5.4L engines. INSTALL new mounts as necessary. CHECK the master and slave cylinder operation. INSPECT the components for damage or wear. INSTALL a new master or slave cylinder as necessary. REFER to Section 308-02. CHECK the input shaft seal and rear main oil seal. REPAIR as necessary. INSTALL a new clutch disc. REFER to Section 308-01. INSPECT the clutch disc surface for a glazed, hardened or damage condition. CARRY OUT a disc check. INSTALL a new clutch disc as necessary. REFER to Section 308-01. INSPECT the clutch pressure plate for wear or damage. INSTALL a new clutch pressure plate as necessary. REFER to Section 308-01. INSPECT the flywheel for damage or wear. CARRY OUT a flywheel runout check. INSTALL a new flywheel as necessary. REFER to Section 303-01A for 4.2L engines or Section 303-01B for 4.6L and 5.4L engines.
<ul style="list-style-type: none"> Clutch chatter noise—noise when clutch pedal is released at initial take-off. Clutch is hard to engage and disengage 	<ul style="list-style-type: none"> Pilot bearing worn, damaged or not correctly aligned in bore. 	<ul style="list-style-type: none"> INSPECT the clutch pressure plate release fingers for uneven wear, clutch components burnt or a seized pilot bearing. INSTALL a new pilot bearing as necessary. REFER to Section 308-01.
<ul style="list-style-type: none"> Clutch vibration 	<ul style="list-style-type: none"> Loose flywheel bolts. Damaged or loose clutch pressure plate. Excessive flywheel runout. 	<ul style="list-style-type: none"> GO to Pinpoint Test L.



BUY IT NOW!

Click Here To Order



DIAGNOSIS AND TESTING (Continued)**Symptom Chart—Transmission (Manual) and Transfer Case Noise/Vibration (Continued)**

Condition	Possible Sources	Action
<ul style="list-style-type: none"> Transmission rattling/clattering noise—noise at idle or on light acceleration from a stop. Gear selection difficult 	<ul style="list-style-type: none"> Gearshift lever joint worn or damaged. Gearshift lever loose. Gearshift linkage rods worn or damaged. 	<ul style="list-style-type: none"> INSTALL a new gearshift lever. REFER to Section 308-03. TIGHTEN the bolts to specification. REFER to Section 308-03. CHECK the linkage bushings for wear. INSTALL new linkage rods as necessary.
<ul style="list-style-type: none"> Transmission rattling/clattering noise—occurs in neutral or in gear, at idle 	<ul style="list-style-type: none"> Incorrect fluid level or fluid quality. 	<ul style="list-style-type: none"> CHECK that the transmission is filled to the correct level and with the specified fluid. REFER to Section 308-00.
<ul style="list-style-type: none"> Transmission rattling/clattering noise—noise at idle in neutral 	<ul style="list-style-type: none"> Worn or rough reverse idler gear. Rough running engine, cylinder misfire. Excessive backlash in gears. Worn countershaft gears. 	<ul style="list-style-type: none"> CHECK the reverse idler gear. REPAIR as necessary. REFER to Section 308-03. CHECK the ignition system. CARRY OUT a cylinder power test. REFER to Section 303-00. CHECK the gear backlash. ADJUST as necessary. REFER to Section 308-03. REPAIR as necessary. REFER to Section 308-03.
<ul style="list-style-type: none"> Transmission whine—a mild whine at extreme speeds or high rpm 	<ul style="list-style-type: none"> Rotating gears/geartrain. 	<ul style="list-style-type: none"> Acceptable noise.
<ul style="list-style-type: none"> Transmission whine—a high pitched whine, also described as a squeal 	<ul style="list-style-type: none"> Transmission gears are worn (high mileage vehicle). Mismatched gear sets. Damaged or worn transmission bearing. 	<ul style="list-style-type: none"> Result of normal gear wear. REPAIR as necessary. REFER to Section 308-03. INSPECT the gear sets for an uneven wear pattern on the face of the gear teeth. REPAIR as necessary. REFER to Section 308-00. INSPECT the transmission bearings. INSTALL new bearings as necessary. REFER to the Section 308-03.
<ul style="list-style-type: none"> Transmission growling/humming—noise occurs in the forward gears. The noise is more prominent when the gear is loaded. The problem gear can be located as the noise occurs in a specific gear position 	<ul style="list-style-type: none"> Gear is cracked, chipped or rough. 	<ul style="list-style-type: none"> INSPECT the transmission gears for damage or wear. INSTALL new gears as necessary. REFER to Section 308-03.
<ul style="list-style-type: none"> Transmission hissing—noise in neutral or in forward gears. As bearings wear or break up, the 	<ul style="list-style-type: none"> Damaged or worn bearings. 	<ul style="list-style-type: none"> INSPECT the transmission bearings. INSTALL new bearings as necessary. REFER to Section 308-03.



BUY IT NOW!

Click Here To Order



DIAGNOSIS AND TESTING (Continued)**Symptom Chart—Transmission (Manual) and Transfer Case Noise/Vibration (Continued)**

Condition	Possible Sources	Action
<ul style="list-style-type: none"> Transmission knocking/thudding—noise at low speeds in forward gears 	<ul style="list-style-type: none"> Bearings with damaged balls or rollers or with pitted and spalled races. 	<ul style="list-style-type: none"> INSPECT the transmission bearings. INSTALL new bearings as necessary. REFER to Section 308-03.
<ul style="list-style-type: none"> Transmission rumble/growl—noise at higher speeds in forward gears, more pronounced in a coast/deceleration condition 	<ul style="list-style-type: none"> Incorrect driveline angle. Driveshaft out of balance or damaged. 	<ul style="list-style-type: none"> CHECK the driveline angle. REPAIR as necessary. REFER to Section 205-00. CHECK the driveshaft for damage, missing balance weights or undercoating. Using the vibration analyzer (VA), CHECK the driveshaft balance. CARRY OUT a driveline vibration test. For additional information, REFER to Section 205-00. REPAIR as necessary.
<ul style="list-style-type: none"> Transmission rumble/growl—noise at all speeds in forward gears, more pronounced in a heavy acceleration condition 	<ul style="list-style-type: none"> Damaged or worn transmission bearing or gears (high mileage vehicles). 	<ul style="list-style-type: none"> CHECK transmission fluid for excessive metal particles. REPAIR as necessary. REFER to Section 308-03.
<ul style="list-style-type: none"> Transfer case whine—noise at all ranges 	<ul style="list-style-type: none"> Incorrect fluid level or fluid quality. Worn oil pump. Under-inflated or oversized tires. 	<ul style="list-style-type: none"> CHECK that the transfer case is filled to the correct level and with the specified fluid. REFER to Section 308-07B. DISASSEMBLE the transfer case. CHECK the oil pump for wear or damage. REPAIR as necessary. REFER to Section 308-07B. CONFIRM that the tires and wheels are correct for the vehicle. CHECK that the tire inflation pressures are correct.
<ul style="list-style-type: none"> Transfer case growl/rumble—noise at all ranges (A small amount of planetary noise can be heard when the transfer case is operated in low range.) 	<ul style="list-style-type: none"> Damaged or worn bearings or planetary gear. 	<ul style="list-style-type: none"> DISASSEMBLE the transfer case. CHECK the bearings or planetary gear for wear or damage. REPAIR as necessary. REFER to Section 308-07B.
<ul style="list-style-type: none"> Transfer case scraping/grating—noise at all ranges 	<ul style="list-style-type: none"> Excessively stretched drive chain hitting the case. 	<ul style="list-style-type: none"> DISASSEMBLE the transfer case. CHECK the drive chain for wear or damage. REPAIR as necessary. REFER to Section 308-07B.
<ul style="list-style-type: none"> Transfer case howl/hum—noise at all ranges or high range only 	<ul style="list-style-type: none"> Worn or damaged sun (input) gear, clutch pack (intermediate) gear or output shaft gear. 	<ul style="list-style-type: none"> DISASSEMBLE the transfer case. CHECK the gears for wear or damage. REPAIR as necessary. REFER to Section 308-07B.



BUY IT NOW!

Click Here To Order



DIAGNOSIS AND TESTING (Continued)**Symptom Chart—Transmission (Manual) and Transfer Case Noise/Vibration (Continued)**

Condition	Possible Sources	Action
<ul style="list-style-type: none"> Transfer case howl/hum—noise at low range only 	<ul style="list-style-type: none"> Worn or damaged intermediate gear and sliding gears (clutch pack). 	<ul style="list-style-type: none"> DISASSEMBLE the transfer case. CHECK the gears for wear or damage. REPAIR as necessary. REFER to Section 308-07B.
<ul style="list-style-type: none"> Transfer case vibration—vibration felt with vehicle in 4WD 	<ul style="list-style-type: none"> Transfer case mounting. Driveshaft out of balance. Excessive pinion flange runout. 	<ul style="list-style-type: none"> GO to Pinpoint Test M.

Symptom Chart—Transmission (Automatic) Noise/Vibration

Condition	Possible Sources	Action
<ul style="list-style-type: none"> Rattle—occurs at idle or at light acceleration from a stop 	<ul style="list-style-type: none"> Damaged engine or transmission mounts. A loose front pipe heat shield. Loose inspection plate or dust cover plate. Loose flexplate to converter nuts. 	<ul style="list-style-type: none"> CHECK the powertrain/drivetrain mounts for damage. CARRY OUT Powertrain/Drivetrain Mount Neutralizing in this section. REPAIR or INSTALL a new heat shield as necessary. CHECK for loose bolts. TIGHTEN to specifications. REFER to Section 307-01B for 4R70W transmissions or Section 307-01A for 4R100 transmissions. CHECK for loose nuts. TIGHTEN to specifications. REFER to Section 307-01B for 4R70W transmissions or Section 307-01A for 4R100 transmissions.
<ul style="list-style-type: none"> Whine—pitch increases with vehicle speed. Starts in first and second gear, decreases or goes away at higher gears 	<ul style="list-style-type: none"> Damaged or worn low one-way clutch. Damaged or worn intermediate one-way clutch. Friction elements. Damaged or worn planetary or sun gear. 	<ul style="list-style-type: none"> INSPECT the transmission for wear or damage. REPAIR or INSTALL new components as necessary. REFER to Section 307-01B for 4R70W transmissions or Section 307-01A for 4R100 transmissions.



BUY IT NOW!

Click Here To Order 



DIAGNOSIS AND TESTING (Continued)**Symptom Chart—Transmission (Automatic) Noise/Vibration (Continued)**

Condition	Possible Sources	Action
<ul style="list-style-type: none"> Whine—the pitch changes with engine speed 	<ul style="list-style-type: none"> A worn or damaged accessory drive component. Incorrect fluid level. Partially blocked filter. Worn or damaged torque converter. Worn or damaged front pump. 	<ul style="list-style-type: none"> CARRY OUT the Engine Accessory Test. REPAIR or INSTALL new components as necessary. CHECK that the transmission is filled to the correct level. ADD fluid as necessary. REFER to Section 307-01B for 4R70W transmissions or Section 307-01A for 4R100 transmissions. INSPECT the filter. CLEAN or INSTALL a new filter as necessary. REFER to Section 307-01B for 4R70W transmissions or Section 307-01A for 4R100 transmissions. CARRY OUT the torque converter service and replacement check. REFER to Section 307-01B for 4R70W transmissions or Section 307-01A for 4R100 transmissions. INSPECT the front pump. INSTALL a new front pump as necessary. REFER to Section 307-01B for 4R70W transmissions or Section 307-01A for 4R100 transmissions.
<ul style="list-style-type: none"> Whine—pitch changes with vehicle speed 	<ul style="list-style-type: none"> Speedometer cable or gears. 	<ul style="list-style-type: none"> REPAIR or INSTALL new cables or gears as necessary.



BUY IT NOW!
Click Here To Order 







DIAGNOSIS AND TESTING (Continued)**Symptom Chart—Transmission (Automatic) Noise/Vibration (Continued)**

Condition	Possible Sources	Action
<ul style="list-style-type: none"> Whine/moan type noise—pitch increases or changes with vehicle speed 	<ul style="list-style-type: none"> Damaged engine or transmission mount. U-joints worn or damaged. Damaged or worn differential ring and pinion. Planetary gears nicked or chipped. 	<ul style="list-style-type: none"> CHECK the powertrain/drivetrain mounts for damage. CARRY OUT Powertrain/Drivetrain Mount Neutralizing in this section. INSPECT the U-joints for wear or damage. INSTALL new U-joints as necessary. REFER to Section 205-01. INSPECT the differential ring and pinion for damage. CARRY OUT the Checking Tooth Contact Pattern and Condition of the Ring and Pinion component test in this section. REPAIR or INSTALL a new differential ring and pinion as necessary. REFER to Section 205-02A for Ford 8.8 rear axles, Section 205-02B for Ford 9.75 rear axles, Section 205-02C for Ford 10.25 rear axles or Section 205-03 for front axles. CHECK the planetary gears for damage. INSTALL new components as necessary. REFER to Section 307-01B for 4R70W transmissions or Section 307-01A for 4R100 transmissions.
<ul style="list-style-type: none"> Whistle—noise is high pitched, constant. Changes in pitch with throttle position 	<ul style="list-style-type: none"> Hydraulic pressure in the main control. Incorrect band/clutch apply pressure. Worn or damaged torque converter. 	<ul style="list-style-type: none"> INSPECT the main control. REPAIR or INSTALL new components as necessary. REFER to Section 307-01B for 4R70W transmissions or Section 307-01A for 4R100 transmissions. CARRY OUT the line pressure tests. REPAIR or INSTALL components as necessary. REFER to Section 307-01B for 4R70W transmissions or Section 307-01A for 4R100 transmissions. CARRY OUT the torque converter service and replacement check. REFER to Section 307-01B for 4R70W transmissions or Section 307-01A for 4R100 transmissions.



BUY IT NOW!

Click Here To Order



DIAGNOSIS AND TESTING (Continued)**Symptom Chart—Transmission (Automatic) Noise/Vibration (Continued)**

Condition	Possible Sources	Action
<ul style="list-style-type: none"> Clunk—occurs when shifting from PARK to a drive or reverse position 	<ul style="list-style-type: none"> Damaged powertrain mounts. Damaged or worn pinion bearings. Worn or galled driveshaft slip yoke splines. Worn friction elements or excessive clutch pack end plate play. 	<ul style="list-style-type: none"> INSPECT the powertrain mounts for damage. INSTALL new mounts as necessary. REFER to Section 307-01B for 4R70W transmissions or Section 307-01A for 4R100 transmissions. CHECK for abnormal bearing play or roughness. INSTALL new bearings as necessary. REFER to Section 205-02A for Ford 8.8 rear axles, Section 205-02B for Ford 9.75 rear axles, Section 205-02C for Ford 10.25 rear axles or Section 205-03 for front axles. CLEAN and INSPECT the splines of the yoke. INSTALL a new slip yoke as necessary. REFER to Section 205-01. INSPECT the transmission for wear. CHECK that all end play and clearances are within specification. REPAIR or INSTALL new components as necessary. REFER to Section 307-01B for 4R70W transmissions or Section 307-01A for 4R100 transmissions.
<ul style="list-style-type: none"> Bump—occurs when shifting from PARK to a drive or reverse position. Similar to Clunk but with no sound 	<ul style="list-style-type: none"> Initial gear engagement. 	<ul style="list-style-type: none"> Acceptable condition.
<ul style="list-style-type: none"> Buzz or hiss 	<ul style="list-style-type: none"> Incorrect driveline angles. Worn or damaged main control solenoids or valves. 	<ul style="list-style-type: none"> CHECK for correct driveline angles. REPAIR as necessary. REFER to Section 205-00. Using a transmission tester, ACTIVATE the solenoids to duplicate sound. INSTALL new components as necessary. REFER to Section 307-01B for 4R70W transmissions or Section 307-01A for 4R100 transmissions.

100% SATISFACTION GUARANTEED

BUY IT NOW!

Click Here To Order



DIAGNOSIS AND TESTING (Continued)

Symptom Chart—Transmission (Automatic) Noise/Vibration (Continued)

Condition	Possible Sources	Action
<ul style="list-style-type: none"> Vibration—a high frequency (20-80 Hz) that is felt through the seat or gear shifter. Changes with engine speed 	<ul style="list-style-type: none"> Transmission cooler lines grounded out. Flexplate to torque converter nuts loose. Fluid filler tube grounded out. Shift cable incorrectly routed, grounded out or loose. 	<ul style="list-style-type: none"> CHECK the transmission cooler lines. REPAIR as necessary. CHECK the flexplate. TIGHTEN to specification. REFER to Section 307-01B for 4R70W transmissions or Section 307-01A for 4R100 transmissions. CHECK the fluid filler tube. REPAIR as necessary. CHECK the shift cable. REPAIR as necessary. REFER to Section 307-05.
<ul style="list-style-type: none"> Shutter or chatter—occurs with light to medium acceleration from low speeds or a stop 	<ul style="list-style-type: none"> Electrical inputs/outputs. Vehicle wiring harness. Incorrect inputs/outputs from the powertrain control module (PCM), digital transmission range (TR) sensor, brake pedal position (BPP) sensor, throttle position (TP) sensor, transmission speed sensor (TSS), output speed shaft (OSS) sensor or the torque converter clutch (TCC). 	<ul style="list-style-type: none"> CARRY OUT a Torque Converter Clutch Operation Test. RUN on-board diagnostics or self-test. REFER to Section 307-01A for 4R100 transmissions or Section 307-01B for 4R70W transmissions. CLEAR the DTC's, road test and rerun on-board diagnostics or self-test.

Pinpoint Tests

The pinpoint tests are a step-by-step diagnostic process designed to determine the cause of a condition. It may not always be necessary to follow a pinpoint test to its conclusion. Carry out only the steps necessary to correct the condition. Then, test the system for normal operation. Sometimes, it is necessary to remove various vehicle components to gain access to the component requiring testing. For additional information, refer to the appropriate section for removal and installation procedures. Reinstall all components after verifying system operation is normal.

PINPOINT TEST A: BRAKE VIBRATION/SHUDDER

CONDITIONS	DETAILS/RESULTS/ACTIONS
A1 ROAD TEST THE VEHICLE—LIGHT BRAKING	<ol style="list-style-type: none"> Check that the wheel and tires are correct for the vehicle. Inspect the tires for abnormal wear patterns.

(Continued)

DIAGNOSIS AND TESTING (Continued)**PINPOINT TEST A: BRAKE VIBRATION/SHUDDER (Continued)**

CONDITIONS	DETAILS/RESULTS/ACTIONS
A1 ROAD TEST THE VEHICLE—LIGHT BRAKING (Continued)	<p data-bbox="785 302 1455 453">2 Road test the vehicle. Warm the brakes by slowing the vehicle a few times from 80-32 km/h (50 to 20 mph) using light braking applications. At highway speeds of 89-97 km/h (55-60 mph), apply the brake using a light pedal force.</p> <ul data-bbox="843 485 1444 541" style="list-style-type: none"> • Is there a vibration/shudder felt in the steering wheel, seat or brake pedal? <p data-bbox="843 573 1028 630">→ Yes GO to A4.</p> <p data-bbox="843 661 1028 718">→ No GO to A2.</p>
A2 ROAD TEST THE VEHICLE—MODERATE TO HEAVY BRAKING	<p data-bbox="785 804 1444 898">1 Road test the vehicle. At highway speeds of 89-97 km/h (55-60 mph), apply the brake using a moderate to heavy pedal force.</p> <ul data-bbox="843 926 1229 953" style="list-style-type: none"> • Is there a vibration/shudder? <p data-bbox="843 984 1318 1041">→ Yes For vehicles with ABS, GO to A3.</p> <p data-bbox="835 1073 1381 1100">For vehicles with standard brakes, GO to A4.</p> <p data-bbox="843 1131 1381 1245">→ No Vehicle is OK. VERIFY condition with customer. TEST the vehicle for normal operation.</p>
A3 NORMAL ACTUATION OF THE ABS SYSTEM DIAGNOSIS	<p data-bbox="785 1335 1444 1633">1 During moderate to heavy braking, noise from the hydraulic control unit (HCU) and pulsation in the brake pedal can be observed. Pedal pulsation coupled with noise during heavy braking or on loose gravel, bumps, wet or snowy surfaces is acceptable and indicates correct functioning of the ABS system. Pedal pulsation or steering wheel nibble (frequency is proportioned to the vehicle speed) indicates a concern with a brake or suspension component.</p> <ul data-bbox="843 1661 1339 1717" style="list-style-type: none"> • Is the vibration/shudder vehicle speed sensitive? <p data-bbox="843 1749 1028 1806">→ Yes GO to A5.</p> <p data-bbox="843 1837 1381 1894">→ No The brake system is operating correctly.</p>

(Continued)

**BUY IT NOW!****Click Here To Order**

DIAGNOSIS AND TESTING (Continued)

PINPOINT TEST A: BRAKE VIBRATION/SHUDDER (Continued)

CONDITIONS	DETAILS/RESULTS/ACTIONS
<p>A4 APPLICATION OF THE PARKING BRAKE</p>	<p>1 NOTE: Begin at the front of the vehicle unless the vibration or shudder has been isolated to the rear.</p> <p>This test is not applicable to vehicles with drum-in-hat type parking brakes. For vehicles with drum-in-hat parking brakes, proceed to the next test. For all other vehicles, apply the parking brake to identify if the problem is in the front or rear brake. At highway speeds of 89-97 km/h (55-60 mph), lightly apply the parking brake until the vehicle slows down. Release the parking brake immediately after the test.</p> <ul style="list-style-type: none"> • Is there a vibration/shudder? <p>→ Yes GO to A8.</p> <p>→ No GO to A5.</p>
<p>A5 CHECK THE FRONT WHEEL BEARINGS</p>	<p>1 Check the front wheel bearings. Refer to Wheel Bearing Check in this section.</p> <ul style="list-style-type: none"> • Are the wheel bearings OK? <p>→ Yes GO to A6.</p> <p>→ No INSPECT the wheel bearings. ADJUST or REPAIR as necessary. TEST the system for normal operation.</p>

(Continued)

100% SATISFACTION GUARANTEED

BUY IT NOW!

Click Here To Order

PayPal American Express Discover MasterCard VISA

DIAGNOSIS AND TESTING (Continued)**PINPOINT TEST A: BRAKE VIBRATION/SHUDDER (Continued)**

CONDITIONS	DETAILS/RESULTS/ACTIONS
A6 CHECK THE FRONT SUSPENSION	<p>1 Check the front suspension for:</p> <ul style="list-style-type: none"> • Broken or loose bolts. • Damaged springs. • Worn or damaged upper and lower control arm bushings. • Loose or rough front bearings. • Uneven tire wear. <p>• Are all the suspension components in satisfactory condition?</p> <p>→ Yes GO to A7.</p> <p>→ No REPAIR or INSTALL new components as necessary. TEST the system for normal operation.</p>
A7 RESURFACE THE FRONT BRAKE DISCS	<p>1  CAUTION: Do not use a bench lathe to machine brake discs.</p> <p>NOTE: Follow the manufacturer's instructions to machine the brake discs. After machining, make sure the brake disc meets the thickness specification.</p> <p>Resurface the front brake discs or drums. REFER to Brake Disc Machining in this section. Road test the vehicle.</p> <ul style="list-style-type: none"> • Is the vibration/shudder present? <p>→ Yes GO to A8.</p> <p>→ No Vehicle is OK.</p>

(Continued)



BUY IT NOW!

Click Here To Order 



DIAGNOSIS AND TESTING (Continued)**PINPOINT TEST A: BRAKE VIBRATION/SHUDDER (Continued)**

CONDITIONS	DETAILS/RESULTS/ACTIONS
A8 CHECK THE REAR SUSPENSION	<p>1 Check the rear suspension for:</p> <ul style="list-style-type: none"> • Broken or loose bolts. • Damaged or worn springs or spring bushings. • Worn or damaged upper and lower control arm bushings. • Worn or damaged trailing arms. • Loose or rough rear bearings. • Uneven tire wear. <p>• Are all the suspension components in satisfactory condition?</p> <p>→ Yes GO to A9.</p> <p>→ No REPAIR or INSTALL new components as necessary. TEST the system for normal operation.</p>
A9 RESURFACE THE REAR BRAKE DISC OR DRUM	<p>1  CAUTION: Do not use a bench lathe to machine brake discs.</p> <p>NOTE: Follow the manufacturer's instructions to machine the brake discs. After machining, make sure the brake disc meets the thickness specification.</p> <p>Resurface the front brake discs. Refer to Brake Disc Machining in this section. Road test the vehicle.</p> <ul style="list-style-type: none"> • Is the vibration/shudder present? <p>→ Yes CHECK the front suspension for wear or damage. RESURFACE the front brake discs. TEST the system for normal operation.</p> <p>→ No Vehicle is OK.</p>



BUY IT NOW!

Click Here To Order



DIAGNOSIS AND TESTING (Continued)

PINPOINT TEST B: ENGINE TICKING NOISE

CONDITIONS	DETAILS/RESULTS/ACTIONS
B1 CHECK FOR TICKING NOISE AT THE FUEL RAIL	<p>1 Disconnect the first fuel line clip.</p> <ul style="list-style-type: none"> • Is the ticking noise gone? → Yes CHECK for TSB for applicable vehicle. REPAIR as necessary. TEST the system for normal operation. → No GO to B2.
B2 CHECK FOR TICKING NOISE AT THE FUEL INJECTOR	<p>1 Using an EngineEAR, listen at the fuel injectors by placing a probe on each injector. To isolate the faulty injector, disconnect the injector electrical connector and listen for the noise.</p> <ul style="list-style-type: none"> • Is the fuel injector the source of the ticking noise? → Yes INSTALL a new fuel injector. REFER to Section 303-04A for 4.2L engines or Section 303-04B for 4.6L and 5.4L engines. TEST the system for normal operation. → No GO to B3.
B3 CHECK THE BELT TENSIONER FOR TICKING NOISE	<p>1 Inspect the accessory drive. Check for the belt tensioner bottoming at end of travel or not at end of stroke.</p> <p>2 Using an EngineEAR, listen at the belt tensioner.</p> <ul style="list-style-type: none"> • Is the belt tensioner the source of the noise? → Yes INSTALL a new belt tensioner. TEST the system for normal operation. → No GO to B4.

(Continued)

100% SATISFACTION GUARANTEED

BUY IT NOW!

Click Here To Order

PayPal American Express Discover MasterCard VISA

DIAGNOSIS AND TESTING (Continued)**PINPOINT TEST B: ENGINE TICKING NOISE (Continued)**

CONDITIONS	DETAILS/RESULTS/ACTIONS
B4 CHECK THE WATER PUMP FOR TICKING NOISE	<p>1 Using an EngineEAR, listen at the water pump for ticking noise.</p> <ul style="list-style-type: none"> • Is the water pump the source of the noise? <p>→ Yes INSTALL a new water pump. REFER to Section 303-03A for standard cooling or Section 303-03B for supercharger cooling. TEST the system for normal operation.</p> <p>→ No GO to B5.</p>
B5 CHECK FOR AN OBSTRUCTION OF THE COOLING FAN	<p>1 Inspect the cooling fan for obstructions.</p> <p>2 Check the cooling fan and shroud for wear or damage.</p> <ul style="list-style-type: none"> • Was there an obstruction or does the cooling fan show signs of damage? <p>→ Yes REPAIR or INSTALL a new cooling fan. REFER to Section 303-03A for standard cooling or Section 303-03B for supercharger cooling. TEST the system for normal operation.</p> <p>→ No GO to B6.</p>
B6 CHECK THE OIL PUMP FOR TICKING NOISE	<p>1 Check the oil pump using EngineEARs and probe at the oil filter adapter to verify the oil pump as a source.</p> <ul style="list-style-type: none"> • Is the oil pump the source of the noise? <p>→ Yes INSTALL a new oil pump. REFER to Section 303-01A for 4.2L engines or Section 303-01B for 4.6L and 5.4L engines. TEST the system for normal operation.</p> <p>→ No GO to B7.</p>

(Continued)



**BUY IT NOW!****Click Here To Order**

DIAGNOSIS AND TESTING (Continued)

PINPOINT TEST B: ENGINE TICKING NOISE (Continued)

CONDITIONS	DETAILS/RESULTS/ACTIONS
<p>B7 CHECK VALVE LIFTERS OR LASH ADJUSTERS FOR CORRECT OPERATION</p>	<p>1 Check valve lifter/lash adjuster for correct operation, using EngineEARS.</p> <ul style="list-style-type: none"> • Are the valve lifters/lash adjusters operating correctly? <p>→ Yes VERIFY customer concern. CONDUCT a diagnosis of other suspect components.</p> <p>→ No INSTALL a new valve lifter/lash adjuster(s). TEST the system for normal operation.</p>

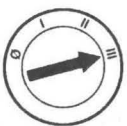
PINPOINT TEST C: ACCESSORY DRIVE BEARING HOOT

CONDITIONS	DETAILS/RESULTS/ACTIONS
<p>C1 CHECK THE ACCESSORY DRIVE IDLER AND TENSIONER PULLEY BEARINGS</p> <div style="text-align: center;"> <p>2</p>  </div> <div style="text-align: center;"> <p>4</p>  </div>	<p>1 Carry out the Vehicle Cold Soak Procedure in this section.</p> <p>3 Place an EngineEAR probe directly on the pulley center post or bolt to verify which bearing is making the noise.</p> <ul style="list-style-type: none"> • Is either bearing making the noise? <p>→ Yes INSTALL a new pulley/idler. CARRY OUT the Vehicle Cold Soak Procedure and TEST the system for normal operation.</p> <p>→ No CONDUCT a diagnosis on other suspect accessory drive components.</p>

100% SATISFACTION GUARANTEED



BUY IT NOW!

Click Here To Order

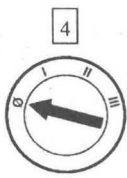
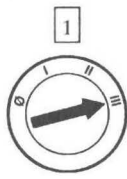

DIAGNOSIS AND TESTING (Continued)

PINPOINT TEST D: POWER STEERING MOAN

CONDITIONS	DETAILS/RESULTS/ACTIONS
<p>D1 CHECK THE POWER STEERING SYSTEM</p> <div style="text-align: center;">  <p>2</p>  <p>4</p> </div>	<p>1 Carry out the Vehicle Cold Soak Procedure in this section.</p> <p>3 Turn the steering wheel while the noise is occurring and listen for changes in sound pitch or loudness.</p> <ul style="list-style-type: none"> • Does the sound pitch or loudness change while turning the steering wheel? <p>→ Yes GO to D2.</p> <p>→ No CONDUCT a diagnosis on other suspect accessory drive components.</p>
<p>D2 VERIFY THE SOURCE</p> <div style="text-align: center;">  <p>1</p>  <p>3</p> </div>	<p>2 Place an EngineEAR probe near the power steering pump/reservoir while the noise is occurring. While an assistant turns the steering wheel, listen for changes in sound pitch or loudness.</p>

(Continued)

100% SATISFACTION GUARANTEED

BUY IT NOW!

Click Here To Order 



DIAGNOSIS AND TESTING (Continued)

PINPOINT TEST D: POWER STEERING MOAN (Continued)

CONDITIONS	DETAILS/RESULTS/ACTIONS
<p>D2 VERIFY THE SOURCE (Continued)</p>	<ul style="list-style-type: none"> • Does the sound pitch or loudness change while turning the steering wheel? → Yes VERIFY that the supply tube to the pump is unobstructed. CHECK the fluid condition and level. DRAIN the fluid and REFILL. REFER to Section 211-02. CARRY OUT the Vehicle Cold Soak Procedure and TEST the system for normal operation. → No Normal system operation.

PINPOINT TEST E: ENGINE DRIVEN COOLING FAN MOAN

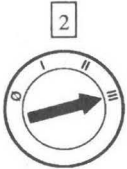
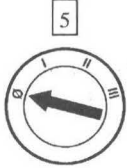
CONDITIONS	DETAILS/RESULTS/ACTIONS
<p>E1 CHECK THE ENGINE DRIVEN COOLING FAN AFTER A COLD SOAK</p> <div style="text-align: center;">   </div>	<ol style="list-style-type: none"> 1 Carry out the Vehicle Cold Soak Procedure in this section. 3 Assess the airflow. 4 Raise the engine speed to 1500 rpm while listening for the moan to increase in proportion to the airflow. <ul style="list-style-type: none"> • Does the moan increase in proportion to the airflow? → Yes TEST the fan for normal operation. If the fan tests normal, GO to E2. Otherwise, REPAIR as necessary. → No Normal system operation.

(Continued)

100% SATISFACTION GUARANTEED



BUY IT NOW!

Click Here To Order



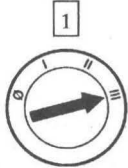

DIAGNOSIS AND TESTING (Continued)

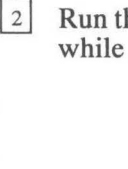
PINPOINT TEST E: ENGINE DRIVEN COOLING FAN MOAN (Continued)

CONDITIONS	DETAILS/RESULTS/ACTIONS
E2 CHECK THE ENGINE DRIVEN COOLING FAN AT NORMAL OPERATING TEMPERATURE	
<div style="text-align: center;">  <p>1</p> </div> <div style="text-align: center;">  <p>3</p> </div>	<div style="text-align: center;">  <p>2</p> </div> <p>Run the engine to normal operating temperature while listening for the moan to stop.</p> <ul style="list-style-type: none"> • Does the moan stop? → Yes Normal clutch operation. → No INSTALL a new fan clutch. TEST the system for normal operation.

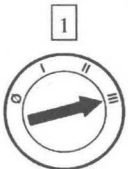
PINPOINT TEST F: DRUMMING NOISE

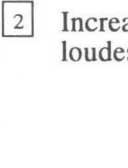
CONDITIONS	DETAILS/RESULTS/ACTIONS
F1 CHECK THE EXHAUST SYSTEM	
<div style="text-align: center;">  <p>1</p> </div> <div style="text-align: center;">  <p>3</p> </div>	<div style="text-align: center;">  <p>2</p> </div> <p>Increase the engine rpm until the noise is the loudest. Note the engine rpm.</p>

(Continued)



BUY IT NOW!

Click Here To Order 







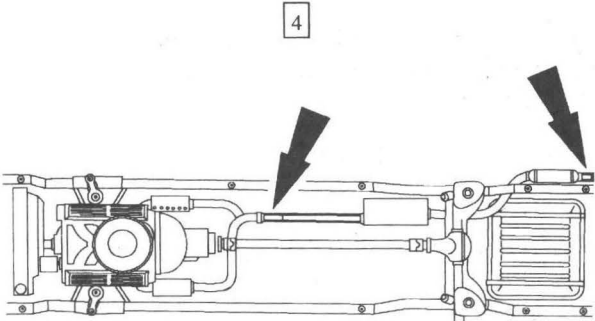
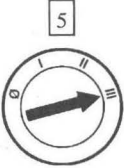

DIAGNOSIS AND TESTING (Continued)

PINPOINT TEST F: DRUMMING NOISE (Continued)

CONDITIONS	DETAILS/RESULTS/ACTIONS
<p>F1 CHECK THE EXHAUST SYSTEM (Continued)</p> <div style="text-align: center;">  </div> <p>DF1768-A</p> <div style="text-align: center;">  </div> <div style="text-align: center;">  </div>	<p>4 Add approximately 9 kg (20 lb) of weight to the exhaust system. First place the weight at the tail pipe and test, then place it at the front pipe.</p> <p>6 Increase the engine rpm and listen for the drumming noise. Note the engine rpm if the noise occurs.</p> <p>8 Using a vibration analyzer (VA), determine the amount of vibration that occurs with the drumming noise.</p> <ul style="list-style-type: none"> • Is the noise/vibration reduced or eliminated, or does the noise/vibration occur at a different rpm? <p>→ Yes CARRY OUT Exhaust System Neutralizing in this section. TEST the system for normal operation.</p> <p>→ No GO to F2.</p>

(Continued)

100% SATISFACTION GUARANTEED

BUY IT NOW!

Click Here To Order





DIAGNOSIS AND TESTING (Continued)

PINPOINT TEST F: DRUMMING NOISE (Continued)

CONDITIONS	DETAILS/RESULTS/ACTIONS
F2 POWERTRAIN/DRIVETRAIN MOUNT NEUTRALIZING	
	<p>1 Carry out Powertrain/Drivetrain Mount Neutralizing in this section. Test the system for normal operation.</p> <ul style="list-style-type: none"> • Is the noise reduced or eliminated? → Yes Vehicle OK. TEST the system for normal operation. → No CONDUCT diagnosis of other suspect components.

PINPOINT TEST G: ENGINE TICKING, KNOCKING OR CONTINUOUS RATTLE

CONDITIONS	DETAILS/RESULTS/ACTIONS
G1 CHECK FOR NOISE AT THE VALVE COVERS AND THE FRONT COVERS (OHC ENGINES)	
<div style="text-align: center;"> <p>2</p>  <p>4</p>  </div>	<p>1 Carry out the Vehicle Cold Soak Procedure in this section.</p> <p>3 NOTE: For a short-duration ticking noise, multiple engine starts may be necessary. Using an EngineEAR, listen closely at the valve covers and the front covers (OHC engines) by placing the probe near the surface of the valve cover and then on the surface front cover.</p> <ul style="list-style-type: none"> • Is the noise source apparent? → Yes REMOVE the appropriate cover and INSPECT for loose, worn/broken components. REPAIR as necessary. TEST the system for normal operation. → No GO to G2.

(Continued)

100% SATISFACTION GUARANTEED





BUY IT NOW!

Click Here To Order

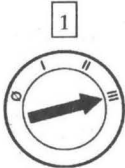

DIAGNOSIS AND TESTING (Continued)

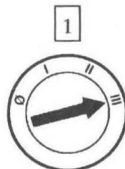
PINPOINT TEST G: ENGINE TICKING, KNOCKING OR CONTINUOUS RATTLE (Continued)

CONDITIONS	DETAILS/RESULTS/ACTIONS
<p>G2 CHECK FOR NOISE AT THE CYLINDER BLOCK</p> <div style="text-align: center;">  <p>1</p> </div> <div style="text-align: center;">  <p>3</p> </div>	<p>2 Using an EngineEAR, listen closely at the cylinder block by placing a probe on or near each freeze plug.</p> <ul style="list-style-type: none"> • Is the noise source apparent? → Yes REPAIR or INSTALL new components as necessary. → No GO to G3.
<p>G3 CHECK FOR NOISE WHILE DISCONNECTING EACH FUEL INJECTOR ELECTRICAL CONNECTOR, ONE AT A TIME</p> <div style="text-align: center;">  <p>1</p> </div> <div style="text-align: center;">  <p>3</p> </div>	<p>2 Disconnect each fuel injector electrical connector, one at a time, to decrease piston force and listen for the noise.</p>

(Continued)

100% SATISFACTION GUARANTEED

BUY IT NOW!

Click Here To Order







DIAGNOSIS AND TESTING (Continued)

PINPOINT TEST G: ENGINE TICKING, KNOCKING OR CONTINUOUS RATTLE (Continued)

CONDITIONS	DETAILS/RESULTS/ACTIONS
G3 CHECK FOR NOISE WHILE DISCONNECTING EACH FUEL INJECTOR ELECTRICAL CONNECTOR, ONE AT A TIME (Continued)	<ul style="list-style-type: none"> • Is the noise reduced or eliminated? → Yes INSTALL a new fuel injector. REFER to Section 303-04A for 4.2L engines or Section 303-04B for 4.6L and 5.4L engines. TEST the system for normal operation. → No INSPECT accessory drive or the transmission as a possible source.

PINPOINT TEST H: FRONT SUSPENSION NOISE

CONDITIONS	DETAILS/RESULTS/ACTIONS
H1 ROAD TEST THE VEHICLE	<ol style="list-style-type: none"> 1 Test drive the vehicle. 2 NOTE: An assistant will be needed for this road test. During the road test, drive the vehicle over a rough road. Using ChassisEARS, determine from which area/component the noise is originating. <ul style="list-style-type: none"> • Is there a squeak, creak or rattle noise? → Yes GO to H2. → No The suspension system is OK. CONDUCT a diagnosis on other suspect systems.
H2 INSPECT THE STEERING SYSTEM	<ol style="list-style-type: none"> 1  WARNING: The electrical power to the air suspension system must be shut off prior to hoisting, jacking or towing an air suspension vehicle. This can be accomplished by turning off the air suspension switch. Failure to do so can result in unexpected inflation or deflation of the air springs, which can result in shifting of the vehicle during these operations. Raise and support the vehicle. 2 Check the steering system for wear or damage. Carry out a steering linkage test. Refer to Section 211-00.

(Continued)



100% SATISFACTION GUARANTEED

BUY IT NOW!

Click Here To Order

PayPal Discover MasterCard VISA

DIAGNOSIS AND TESTING (Continued)

PINPOINT TEST H: FRONT SUSPENSION NOISE (Continued)

CONDITIONS	DETAILS/RESULTS/ACTIONS
H2 INSPECT THE STEERING SYSTEM (Continued)	
	<p>3 Inspect the tire wear pattern. Refer to Tire Wear Chart in Tire Wear Patterns and Frequency Calculations in this section.</p> <ul style="list-style-type: none"> • Are the steering components worn or damaged? <p>→ Yes REPAIR the steering system. INSTALL new components as necessary. TEST the system for normal operation.</p> <p>→ No GO to H3.</p>
H3 FRONT SHOCK ABSORBER/STRUT CHECK	
	<p>1 Check the front shock absorbers/strut mounts for loose bolts or nuts.</p> <p>2 Check the front shock absorbers/struts for wear or damage. Carry out a “bounce test”</p> <ul style="list-style-type: none"> • Are the front shock absorbers/struts loose or damaged? <p>→ Yes TIGHTEN to specifications if loose. INSTALL new front shock absorbers/struts if damaged. TEST the system for normal operation.</p> <p>→ No GO to H4.</p>
H4 CHECK THE FRONT SPRINGS	
	<p>1 Check the front spring and front spring mounts/brackets for wear or damage.</p> <ul style="list-style-type: none"> • Are the front springs or spring mounts/brackets worn or damaged? <p>→ Yes REPAIR or INSTALL new components as necessary. TEST the system for normal operation.</p> <p>→ No GO to H5.</p>

(Continued)

100% SATISFACTION GUARANTEED

BUY IT NOW!

Click Here To Order

PayPal Discover MasterCard VISA

DIAGNOSIS AND TESTING (Continued)**PINPOINT TEST H: FRONT SUSPENSION NOISE (Continued)**

CONDITIONS	DETAILS/RESULTS/ACTIONS
H5 CHECK THE CONTROL ARMS/RADIUS ARMS	<ol style="list-style-type: none"> 1 Inspect the control arm bushings for wear or damage. 2 Inspect for twisted or bent control arms/radius arms. <ul style="list-style-type: none"> • Are the control arms/radius arms damaged or worn? → Yes REPAIR or INSTALL new components as necessary. TEST the system for normal operation. → No GO to H6.
H6 CHECK THE STABILIZER BAR/TRACK BAR	<ol style="list-style-type: none"> 1 Check the stabilizer bar/track bar bushings and links for damage or wear. 2 Check the stabilizer bar/track bar for damage. 3 Check for loose or damaged stabilizer bar isolators or brackets. <ul style="list-style-type: none"> • Are the stabilizer bar/track bar components loose, worn or damaged? → Yes REPAIR or INSTALL new components as necessary. TEST the system for normal operation. → No Suspension system OK. CONDUCT diagnosis on other suspect systems.

PINPOINT TEST I: REAR SUSPENSION NOISE

CONDITIONS	DETAILS/RESULTS/ACTIONS
I1 ROAD TEST THE VEHICLE	
	<ol style="list-style-type: none"> 1 Test drive the vehicle.

(Continued)



BUY IT NOW!
Click Here To Order



DIAGNOSIS AND TESTING (Continued)**PINPOINT TEST I: REAR SUSPENSION NOISE (Continued)**

CONDITIONS	DETAILS/RESULTS/ACTIONS
I1 ROAD TEST THE VEHICLE (Continued)	<p data-bbox="754 296 1426 464">2 NOTE: An assistant will be needed for this road test. During the road test, drive the vehicle over a rough road. Using ChassisEARS, determine from which area/component the noise is originating.</p> <ul data-bbox="816 491 1324 525" style="list-style-type: none"> • Is there a squeak, creak or rattle noise? <p data-bbox="816 552 995 611">→ Yes GO to I2.</p> <p data-bbox="816 638 1419 730">→ No The suspension system is OK. CONDUCT a diagnosis on other suspect systems.</p>
I2 REAR SHOCK ABSORBER/STRUT CHECK	<p data-bbox="754 814 1434 1066">1  WARNING: The electrical power to the air suspension system must be shut off prior to hoisting, jacking or towing an air suspension vehicle. This can be accomplished by turning off the air suspension switch. Failure to do so can result in unexpected inflation or deflation of the air springs, which can result in shifting of the vehicle during these operations. Raise and support the vehicle.</p> <p data-bbox="754 1150 1376 1209">2 Check the rear shock absorber/strut mounts for loose bolts or nuts.</p> <p data-bbox="754 1262 1412 1320">3 Check the rear shock absorbers/struts for damage. Carry out a shock absorber check.</p> <ul data-bbox="816 1348 1381 1407" style="list-style-type: none"> • Are the rear shock absorbers/struts loose or damaged? <p data-bbox="816 1434 1419 1581">→ Yes TIGHTEN to specifications if loose. INSTALL new rear shock absorbers/struts if damaged. TEST the system for normal operation.</p> <p data-bbox="816 1608 995 1667">→ No GO to I3.</p>

(Continued)



BUY IT NOW!

Click Here To Order



DIAGNOSIS AND TESTING (Continued)**PINPOINT TEST I: REAR SUSPENSION NOISE (Continued)**

CONDITIONS	DETAILS/RESULTS/ACTIONS
I3 CHECK THE REAR SPRINGS	<p>1 Check the rear springs and rear spring mounts/brackets for wear or damage.</p> <ul style="list-style-type: none"> • Are the rear springs or spring mounts/brackets worn or damaged? <p>→ Yes REPAIR or INSTALL new components as necessary. TEST the system for normal operation.</p> <p>→ No GO to I4.</p>
I4 CHECK THE CONTROL ARMS/TRAILING ARMS	<p>1 Inspect the control arm/trailing arm bushings for wear or damage. Check for loose control arm/trailing arm bolts.</p> <p>2 Inspect for twisted or bent control arms/trailing arms.</p> <ul style="list-style-type: none"> • Are the control arms/trailing arms loose, damaged or worn? <p>→ Yes REPAIR or INSTALL new components as necessary. TEST the system for normal operation.</p> <p>→ No GO to I5.</p>
I5 CHECK THE STABILIZER BAR/TRACK BAR	<p>1 Check the stabilizer bar/track bar bushings and links for damage or wear.</p> <p>2 Check the stabilizer bar/track bar for damage.</p>

(Continued)

100% SATISFACTION GUARANTEED

BUY IT NOW!

Click Here To Order



DIAGNOSIS AND TESTING (Continued)**PINPOINT TEST I: REAR SUSPENSION NOISE (Continued)**

CONDITIONS	DETAILS/RESULTS/ACTIONS
I5 CHECK THE STABILIZER BAR/TRACK BAR (Continued)	<p data-bbox="760 304 1434 367">3 Check for loose or damaged stabilizer bar isolators or brackets.</p> <ul data-bbox="823 388 1387 451" style="list-style-type: none"> • Are the stabilizer bar/track bar components loose, worn or damaged? <p data-bbox="823 472 1403 598">→ Yes REPAIR or INSTALL new components as necessary. Test the system for normal operation.</p> <p data-bbox="823 619 1324 714">→ No Suspension system OK. CONDUCT diagnosis on other suspect systems.</p>

PINPOINT TEST J: WHEEL AND TIRE

CONDITIONS	DETAILS/RESULTS/ACTIONS
J1 ROAD TEST THE VEHICLE	<p data-bbox="760 913 1434 1134">1 NOTE: Wheel or tire vibrations felt in the steering wheel are most likely related to the front wheel or tire. Vibration felt through the seat are most likely related to the rear wheel or tire. This may not always be true, but it can help to isolate the problem to the front or rear of the vehicle. Test drive the vehicle at different speed ranges.</p> <p data-bbox="760 1165 1434 1291">2 During the road test, if the vibration can be eliminated by placing the vehicle in neutral or is affected by the speed of the engine, the cause is not the wheels or tires.</p> <ul data-bbox="823 1323 1223 1354" style="list-style-type: none"> • Is there a vibration and noise? <p data-bbox="823 1375 1003 1438">→ Yes GO to J2.</p> <p data-bbox="823 1459 1395 1554">→ No The wheel and tires are OK. CONDUCT a diagnosis on other suspect systems.</p>

(Continued)



BUY IT NOW!

Click Here To Order



DIAGNOSIS AND TESTING (Continued)

PINPOINT TEST J: WHEEL AND TIRE (Continued)

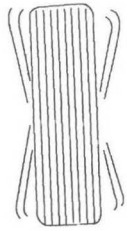
CONDITIONS	DETAILS/RESULTS/ACTIONS
<p>J2 CHECK THE FRONT WHEEL BEARINGS</p>	<p>1 Check the front wheel bearings. Refer to Wheel Bearing Check in this section.</p> <ul style="list-style-type: none"> • Are the wheel bearings OK? <p>→ Yes GO to J3.</p> <p>→ No INSPECT the wheel bearings. ADJUST or REPAIR as necessary. TEST the system for normal operation.</p>
<p>J3 INSPECT THE TIRES</p>	<p>1 Check the tires for missing weights.</p> <p>2 Check the wheels for damage.</p> <p>3 Inspect the tire wear pattern. Refer to the Tire Wear Patterns chart in this section.</p> <ul style="list-style-type: none"> • Do the tires have an abnormal wear pattern? <p>→ Yes CORRECT the condition that caused the abnormal wear. INSTALL new tire(s). TEST the system for normal operation.</p> <p>→ No GO to J4.</p>
<p>J4 TIRE ROTATION DIAGNOSIS</p> <div style="text-align: center;"> <p>1</p>  </div> <p>DF1713-A</p>	<p>1 Spin the tires slowly and watch for signs of lateral runout.</p>

(Continued)

100% SATISFACTION GUARANTEED

BUY IT NOW!

Click Here To Order

DIAGNOSIS AND TESTING (Continued)

PINPOINT TEST J: WHEEL AND TIRE (Continued)

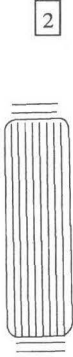
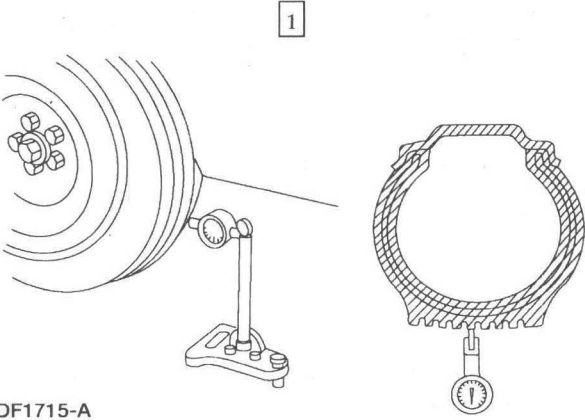
CONDITIONS	DETAILS/RESULTS/ACTIONS
<p>J4 TIRE ROTATION DIAGNOSIS (Continued)</p> <div style="text-align: center;">  </div> <p>DF1714-A</p>	<p>2 Spin the tires slowly and watch for signs of radial runout.</p> <ul style="list-style-type: none"> • Are there signs of visual runout? <p>→ Yes GO to J5.</p> <p>→ No CHECK the wheel and tire balance. CORRECT as necessary. TEST the system for normal operation.</p>
<p>J5 RADIAL RUNOUT CHECK ON THE TIRE</p> <div style="text-align: center;">  </div> <p>DF1715-A</p>	<p>1 Measure the radial runout of the wheel and tire assembly. A typical specification for total radial runout is 1.14 mm (0.04 in).</p> <ul style="list-style-type: none"> • Is the radial runout within specifications? <p>→ Yes GO to J8.</p> <p>→ No GO to J6.</p>
<p>J6 RADIAL RUNOUT CHECK ON THE WHEEL</p>	<p>1 Measure the radial runout of the wheel. A typical specification for total radial runout is 1.14 mm (0.04 in).</p> <ul style="list-style-type: none"> • Is the radial runout within specifications? <p>→ Yes INSTALL a new tire. TEST the system for normal operation.</p> <p>→ No GO to J7.</p>

(Continued)

100% SATISFACTION GUARANTEED

BUY IT NOW!

Click Here To Order





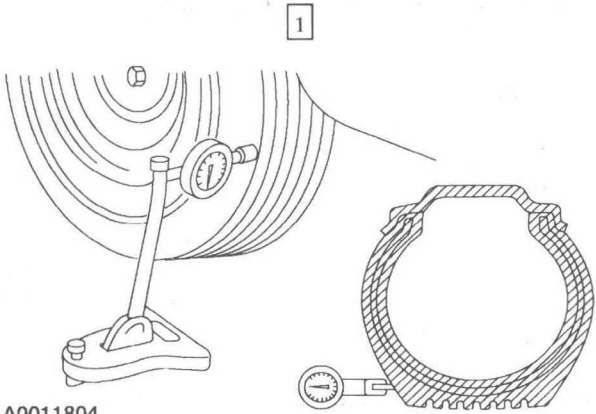

DIAGNOSIS AND TESTING (Continued)**PINPOINT TEST J: WHEEL AND TIRE (Continued)**

CONDITIONS	DETAILS/RESULTS/ACTIONS
J7 CHECK THE HUB/BRAKE DISC OR DRUM PILOT RUNOUT OR BOLT CIRCLE RUNOUT	<p>1 Measure the pilot or bolt circle runout. A typical specification for radial runout is:</p> <ul style="list-style-type: none"> • Pilot runout— less than 0.15 mm (0.006 inch). • Bolt circle runout— less than 0.38 mm (0.015 inch). <p>• Is the radial runout within specifications?</p> <p>→ Yes INSTALL a new wheel. TEST the system for normal operation.</p> <p>→ No REPAIR or INSTALL new components as necessary. REFER to Section 204-01A for 2-wheel drive front wheels, Section 204-01B for 4-wheel drive front wheels or Section 204-02 for the rear wheels.</p>
J8 LATERAL RUNOUT CHECK ON THE TIRE  <p>A0011804</p>	<p>1 Measure the lateral runout of the wheel and tire assembly. A typical specification for total lateral runout is 1.14 mm (0.04 in).</p> <p>• Is the lateral runout within specifications?</p> <p>→ Yes Wheel and tires OK. CONDUCT diagnosis on other suspect systems.</p> <p>→ No GO to J9.</p>
J9 LATERAL RUNOUT CHECK ON THE WHEEL	<p>1 Measure the lateral runout of the wheel. A typical specification for total radial runout is 1.14 mm (0.04 in).</p> <p>• Is the lateral runout within specifications?</p> <p>→ Yes INSTALL a new tire. TEST the system for normal operation.</p> <p>→ No GO to J10.</p>

(Continued)

**BUY IT NOW!****Click Here To Order**

PayPal

American Express
CardsDiscover
Novus

MasterCard

VISA

Ford Motor Company

**TECHNICAL
SUPPORT OPERATIONS**
Automotive Consumer Services Group

100% SATISFACTION GUARANTEED

BUY IT NOW!

Click Here To Order 

LITHO IN U.S.A.
PG-2392



FCS-12272-01-1

Ford Motor Company

2001 Workshop Manual



F-150

VOLUME 2



184356800



BUY IT NOW!

Click Here To Order 

PayPal

Discover
Cards

DISCOVER
NEWUS

MasterCard

VISA

2001 F-150

TABLE OF CONTENTS

INTRODUCTION

GENERAL INFORMATION Volume 1

SERVICE INFORMATION

Identification Codes	100-01
Jacking and Lifting.....	100-02
Noise, Vibration and Harshness	100-04

CHASSIS Volume 1

SUSPENSION

Suspension System — General Information.....	204-00
Front Suspension — 4x2	204-01A
Front Suspension — 4x4	204-01B
Rear Suspension	204-02
Wheels and Tires.....	204-04

DRIVELINE

Driveline System — General Information.....	205-00
Driveshaft	205-01
Rear Drive Axle/Differential —	
Ford 8.8-Inch Ring Gear.....	205-02A
Rear Drive Axle/Differential —	
Ford 9.75-Inch Ring Gear.....	205-02B
Rear Drive Axle/Differential —	
Ford 10.25-Inch Ring Gear.....	205-02C
Front Drive Axle/Differential —	
Ford 8.8-Inch Ring Gear.....	205-03
Front Drive Halfshafts.....	205-04

BRAKE SYSTEM

Brake System — General Information	206-00
Drum Brake	206-02
Front Disc Brake.....	206-03
Rear Disc Brake	206-04
Parking Brake and Actuation	206-05
Hydraulic Brake Actuation	206-06
Power Brake Actuation	206-07
Anti-Lock Control — Rear.....	206-09A
Anti-Lock Control — 4-Wheel	206-09B

STEERING SYSTEM

Steering System — General Information.....	211-00
Power Steering	211-02
Steering Linkage	211-03
Steering Column	211-04
Steering Column Switches	211-05

POWERTRAIN..... Volume 2

ENGINE

Engine System — General Information.....	303-00
Engine — 4.2L	303-01A
Engine — 4.6L and 5.4L	303-01B
Engine Cooling.....	303-03A
Supercharger Cooling	303-03B
Fuel Charging and Controls — 4.2L.....	303-04A
Fuel Charging and Controls —	
4.6L (2V) and 5.4L (2V).....	303-04B
Fuel Charging and Controls —	
Natural Gas Vehicle	303-04C
Fuel Charging and Controls —	
Bi-Fuel Vehicles	303-04D
Accessory Drive	303-05
Starting System.....	303-06
Engine Ignition — 4.2L.....	303-07A
Engine Ignition — 4.6L (2V) and 5.4L (2V).....	303-07B
Engine Emission Control.....	303-08
Intake Air Distribution and Filtering	303-12
Evaporative Emissions.....	303-13
Electronic Engine Controls.....	303-14

AUTOMATIC TRANSMISSION

Automatic Transmission — 4R100.....	307-01A
Automatic Transmission — 4R70W	307-01B
Transaxle/Transmission Cooling	307-02
Automatic Transaxle/Transmission	
External Controls.....	307-05

NOTE: The descriptions and specifications contained in this manual were in effect at the time this manual was approved for printing. Ford Motor Company reserves the right to discontinue models at any time, or change specifications or design without notice and without incurring any obligation.

PUBLICATIONS ORDERING INFORMATION

To obtain information about ordering additional copies of this publication or to order any other Ford or Lincoln/Mercury publications, call 1-800-782-4356. Available publications include workshop manuals, wiring diagrams, PC/ED Manuals and Owner Guides.

To obtain a publications order form by writing to: Ford Publications, care of Helm Inc., P.O. Box 07150, Detroit, MI 48207.

Electronic or mechanical, including photocopying, recording, or by any information storage and permitted without written authorization from Ford Motor Company.



BUY IT NOW!

Click Here To Order



2001 F-150

TABLE OF CONTENTS

MANUAL TRANSMISSION, CLUTCH AND TRANSFER CASE

Manual Transaxle/Transmission and Clutch — General Information	308-00
Clutch	308-01
Clutch Controls.....	308-02
Manual Transaxle/Transmission.....	308-03
Transfer Case — General Information	308-07A
Transfer Case.....	308-07B

EXHAUST SYSTEM

Exhaust System — General Information	309-00
--	--------

FUEL SYSTEM

Fuel System — General Information	310-00A
Fuel System — General Information — Natural Gas	310-00B
Fuel System — General Information — Bi-Fuel Vehicles	310-00C
Fuel Tank and Lines.....	310-01A
Fuel Tank and Lines — Natural Gas	310-01B
Fuel Tank and Lines — Bi-Fuel Vehicles	310-01C
Acceleration Control.....	310-02
Vehicle Speed Control.....	310-03

ELECTRICAL..... Volume 1

CLIMATE CONTROL SYSTEM

Climate Control System — General Information.....	412-00
Air Distribution and Filtering	412-01
Heating and Ventilation	412-02
Air Conditioning	412-03
Control Components	412-04

INSTRUMENTATION AND WARNING SYSTEMS

Instrument Cluster and Panel Illumination.....	413-00
Instrument Cluster — Conventional.....	413-01A
Instrument Cluster — Natural Gas Vehicle.....	413-01B
Instrument Cluster — Bi-Fuel Vehicles.....	413-01C
Horn	413-06
Warning Devices	413-09

BATTERY AND CHARGING SYSTEM

Charging System — General Information.....	414-00
Battery, Mounting and Cables	414-01
Generator and Regulator.....	414-02

AUDIO SYSTEMS

Entertainment System — General Information.....	415-00
Audio Unit	415-01
Antenna	415-02
Speakers.....	415-03
Video System.....	415-07

LIGHTING

Exterior Lighting.....	417-01
Interior Lighting	417-02
Daytime Running Lamps.....	417-04

ELECTRICAL DISTRIBUTION

Module Communications Network	418-00
Module Configuration.....	418-01

ELECTRONIC FEATURE GROUP

Anti-Theft — PATS	419-01
Remote Convenience	419-02
Multifunction Electronic Control Modules	419-10
Electronic Compass	419-11

BODY AND PAINT..... Volume 1

BODY

Body System — General Information.....	501-00
Front End Body Panels	501-02
Body Closures.....	501-03
Pickup Bed and Platform Body	501-04
Interior Trim and Ornamentation	501-05
Exterior Trim and Ornamentation.....	501-08
Rear View Mirrors	501-09
Seating.....	501-10
Glass, Frames and Mechanisms.....	501-11
Instrument Panel and Console.....	501-12
Handles, Locks, Latches and Entry Systems.....	501-14
Wipers and Washers.....	501-16
Roof Opening Panel.....	501-17
Bumpers	501-19
Occupant Restraints — Active	501-20A
Occupant Restraints — Passive — Supplemental Air Bag System	501-20B

FRAME AND MOUNTING

Full Frame and Body Mounting.....	502-02
-----------------------------------	--------

INDEX



BUY IT NOW!

Click Here To Order



INTRODUCTION

NOTE: The descriptions and specifications contained in this manual were in effect at the time this manual was approved for printing. Ford Motor Company reserves the right to discontinue models at any time, or change specifications or design without notice and without incurring any obligation.

IMPORTANT SAFETY NOTICE

Appropriate service methods and procedures are essential for the safe, reliable operation of all motor vehicles as well as the personal safety of the individual doing the work. This manual provides general directions for performing service with tested, effective techniques. Following them will help assure reliability.

There are numerous variations in procedure, techniques, tools and parts for servicing vehicles, as well as in the skill of the individual doing the work. This manual cannot possibly anticipate all such variations and provide advice or cautions as to each. Accordingly, anyone who departs from the instructions provided in this manual must first establish that he comprises neither his personal safety nor the vehicle integrity by his choice of methods, tools or parts.

NOTES, CAUTIONS, AND WARNINGS

As you read through the procedures, you will come across **NOTES**, **CAUTIONS**, and **WARNINGS**. Each one is there for a specific purpose. **NOTES** give you added information that will help you to perform a particular procedure. **CAUTIONS** are given to prevent you from making an error that could damage the vehicle. **WARNINGS** remind you to be especially careful in those areas where carelessness can cause you personal injury. The following list contains some general **WARNINGS** that you should follow when you work on a vehicle.

- **ALWAYS WEAR SAFETY GLASSES FOR EYE PROTECTION.**
- **USE SAFETY STANDS WHENEVER A PROCEDURE REQUIRES YOU TO BE UNDER THE VEHICLE.**
- **MAKE SURE THAT THE IGNITION SWITCH IS ALWAYS IN THE OFF POSITION, UNLESS OTHERWISE REQUIRED BY THE PROCEDURE.**
- **SET THE PARKING BRAKE WHEN WORKING ON THE VEHICLE. IF YOU HAVE AN AUTOMATIC TRANSMISSION, SET IN PARK UNLESS INSTRUCTED OTHERWISE FOR A SPECIFIC OPERATION. IF YOU HAVE A MANUAL TRANSMISSION, IT SHOULD BE IN REVERSE (ENGINE OFF) OR NEUTRAL (ENGINE ON) UNLESS INSTRUCTED OTHERWISE FOR A SPECIFIC OPERATION. PLACE WOOD BLOCKS (4" X 4" OR LARGER) AGAINST THE FRONT AND REAR SURFACES OF THE TIRES TO HELP PREVENT THE VEHICLE FROM MOVING.**
- **OPERATE THE ENGINE ONLY IN A WELL-VENTILATED AREA TO AVOID THE DANGER OF CARBON MONOXIDE POISONING.**
- **KEEP YOURSELF AND YOUR CLOTHING AWAY FROM MOVING PARTS WHEN THE ENGINE IS RUNNING, ESPECIALLY THE DRIVE BELTS.**
- **TO PREVENT SERIOUS BURNS, AVOID CONTACT WITH HOT METAL PARTS SUCH AS THE RADIATOR, EXHAUST MANIFOLD, TAIL PIPE, THREE-WAY CATALYTIC CONVERTER AND MUFFLER.**
- **DO NOT SMOKE WHILE WORKING ON A VEHICLE.**

TO AVOID INJURY, ALWAYS REMOVE RINGS, WATCHES, LOOSE HANGING JEWELRY AND LOOSE CLOTHING BEFORE WORKING ON A VEHICLE.

BEFORE WORKING UNDER THE HOOD, KEEP HANDS AND OTHER OBJECTS CLEAR OF



BUY IT NOW!

Click Here To Order



GROUP

Powertrain

3

SECTION TITLE	PAGE
Engine System — General Information	303-00-1
Engine — 4.2L	303-01A-1
Engine — 4.6L and 5.4L	303-01B-1
Engine Cooling	303-03A-1
Supercharger Cooling	303-03B-1
Fuel Charging and Controls — 4.2L	303-04A-1
Fuel Charging and Controls — 4.6L (2V) and 5.4L (2V)	303-04B-1
Fuel Charging and Controls — Natural Gas Vehicle	303-04C-1
Fuel Charging and Controls — Bi-Fuel Vehicles	303-04D-1
Accessory Drive	303-05-1
Starting System	303-06-1
Engine Ignition — 4.2L	303-07A-1
Engine Ignition — 4.6L (2V) and 5.4L (2V)	303-07B-1
Engine Emission Control	303-08-1
Intake Air Distribution and Filtering	303-12-1
Evaporative Emissions	303-13-1
Electronic Engine Controls	303-14-1
Automatic Transmission — 4R100	307-01A-1
Automatic Transmission — 4R70W	307-01B-1
Transaxle/Transmission Cooling	307-02-1
Automatic Transaxle/Transmission External Controls	307-05-1
Manual Transaxle/Transmission and Clutch — General Information	308-00-1
Clutch	308-01-1
Clutch Controls	308-02-1
Manual Transaxle/Transmission	308-03-1
Transfer Case — General Information	308-07A-1
Transfer Case	308-07B-1
Exhaust System — General Information	309-00-1
Fuel System — General Information	310-00A-1
Fuel System — General Information — Natural Gas	310-00B-1
Fuel System — General Information — Bi-Fuel Vehicles	310-00C-1
Fuel Tank and Lines	310-01A-1
Fuel Tank and Lines — Natural Gas	310-01B-1
Fuel Tank and Lines — Bi-Fuel Vehicles	310-01C-1
Acceleration Control	310-02-1
Vehicle Speed Control	310-03-1

SECTION 303-00 Engine System — General Information



BUY IT NOW!

Click Here To Order



CONTENTS

PAGE

DESCRIPTION AND OPERATION

Engine303-00-4

DIAGNOSIS AND TESTING

Engine303-00-4
 Component Tests303-00-9
 Compression Test—Compression Gauge Check303-00-10
 Cylinder Leakage Detection303-00-11
 Excessive Engine Oil Consumption.....303-00-14
 Inspection and Verification303-00-5
 Intake Manifold Vacuum Test.....303-00-13
 Oil Consumption Test303-00-11
 Symptom Chart303-00-6
 Valve Train Analysis—Engine Off—Valve Cover Removed303-00-15
 Valve Train Analysis—Engine Running303-00-15

GENERAL PROCEDURES

Bearing —Inspection303-00-48
 Camshaft —End Play Push Rod Engines.....303-00-21
 Camshaft —End Play, OHC Engines303-00-22
 Camshaft —Lobe Lift303-00-23
 Camshaft —Lobe Surface.....303-00-23
 Camshaft —Runout303-00-24
 Camshaft Journal —Clearance, Plastigage Method.....303-00-21
 Camshaft Journal —Clearance, Push Rod Engines, Micrometer Method303-00-20
 Camshaft Journal —Diameter.....303-00-20
 Connecting Rod —Bearing Journal Clearance.....303-00-35
 Connecting Rod —Bend303-00-34
 Connecting Rod —Bushing Diameter303-00-34
 Connecting Rod —Cleaning303-00-33
 Connecting Rod —Large End Bore303-00-33
 Connecting Rod —Piston Pin Side Clearance.....303-00-35
 Connecting Rod —Twist303-00-34
 Crankshaft —Connecting Rod Journal Taper, Out of Round303-00-27
 Crankshaft —End Play.....303-00-26
 Crankshaft —Runout303-00-27
 Crankshaft Main Bearing Journal —Clearance303-00-25
 Crankshaft Main Bearing Journal —Diameter303-00-24
 Crankshaft Main Bearing Journal —Taper.....303-00-25
 Cylinder Block —Core Plug Replacement.....303-00-43
 Cylinder Bore —Cleaning303-00-43
 Cylinder Bore —Out-of-Round.....303-00-28
 Cylinder Bore —Taper.....303-00-28
 Cylinder Head —Distortion303-00-42
 Exhaust Manifold —Inspection303-00-47
 Piston —Diameter303-00-30
 Piston —Inspection303-00-28
 Piston —Runout303-00-33
 Piston —Taper.....303-00-29
 Piston —Twist.....303-00-31

CONTENTS	PAGE
Piston — Ring-to-Groove Clearance	303-00-32
Piston — Selection	303-00-31
Piston — to Cylinder Bore Clearance	303-00-30
Push Rods — Cleaning	303-00-19
Push Rods — Inspection	303-00-19
Rocker Arms — Cleaning	303-00-18
Rocker Arms — Inspection	303-00-19
Roller Follower — Inspection	303-00-36
Spark Plug — Inspection	303-00-45
Sprockets	303-00-18
Valve — Guide Inner Diameter	303-00-39
Valve — Guide Reaming	303-00-39
Valve — Inspection	303-00-39
Valve — Seat Inspection	303-00-41
Valve — Seat Runout	303-00-42
Valve — Seat Width	303-00-42
Valve — Spring Free Length	303-00-40
Valve — Spring Installed Length	303-00-40
Valve — Spring Squareness	303-00-40
Valve — Spring Strength	303-00-41
Valve — Stem Diameter	303-00-37
Valve — Stem to Valve Guide Clearance	303-00-38
Valve Tappet — Inspection	303-00-37
SPECIFICATIONS	303-00-48



BUY IT NOW!

Click Here To Order



DESCRIPTION AND OPERATION

Engine

NOTE: This section contains information, steps and procedures that may not be specific to your engine.

This section covers general procedures and diagnosis and testing of the engine system, except for exhaust emission control devices, which are covered in the Powertrain Control/Emissions Diagnosis Manual.

The engine incorporates the following features:

- a closed positive crankcase ventilation (PCV) system. For additional information, refer to Section 303-08.
- an exhaust emission control system. For additional information, refer to Section 303-08.
- an evaporative emission control system. For additional information, refer to Section 303-13.

Some engines incorporate a fail-safe cooling system. Refer to the appropriate section in Group 303 for the procedure.

The engine, fuel system, ignition system, emissions system and exhaust system all affect exhaust emission levels and must be maintained according to the maintenance schedule. Refer to the scheduled Maintenance Guide.



Correct engine identification is required to order parts. Refer to the appropriate section in Group 303 for the procedure.

For complete vehicle and engine identification codes, refer to Section 100-01.

DIAGNOSIS AND TESTING

Engine

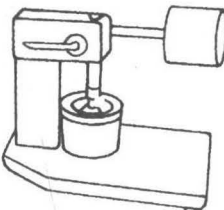
Special Tool(s)

	Commercially Available Leakdown Tester —
	Quick Disconnect Compression Tester 134-R0212 or equivalent
	Cup Shaped Adapter 303-007 (TOOL-6565-AB) or equivalent

(Continued)

Special Tool(s)

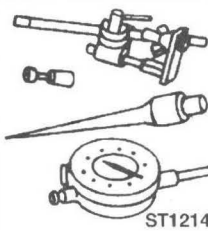
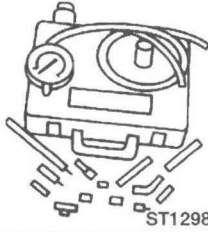
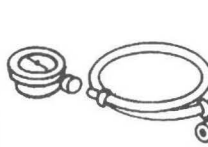
	Dial Indicator with Bracketry 100-002 (TOOL-4201-C) or equivalent
	Engine Cylinder Leak Detection/Air Pressurization Kit 014-00708 or equivalent
	Oil Pressure Tester 303-088 (T73L-6600-A)

(Continued)





BUY IT NOW!

Click Here To Order



DIAGNOSIS AND TESTING (Continued)

Special Tool(s)

 <p>ST1300-A</p>	<p>12 Volt Master UV Diagnostic Inspection Kit 164-R0756 or equivalent (Leak Detector)</p>
 <p>ST1297-A</p>	<p>Vacuum/Pressure Tester 164-R0253 or equivalent</p>

Materials

Item	Specification
Gasoline Engine Oil Dye 164-R3705 or equivalent	ESE-M99C103-B1
Engine Oil	Refer to owner literature

Inspection and Verification

1. Verify the customer concern by operating the engine to duplicate the condition.
2. Visually inspect for obvious signs of mechanical damage. Refer to the following chart.

Visual Inspection Chart

Mechanical
<ul style="list-style-type: none"> • Engine coolant leaks • Engine oil leaks • Fuel leaks • Damaged or severely worn parts • Loose mounting bolts, studs and nuts

3. If the inspection reveals obvious concerns that can be readily identified, repair as necessary.
4. If the concerns remain after the inspection, determine the symptoms and go to the Symptom Chart.

100% SATISFACTION GUARANTEED

BUY IT NOW!

Click Here To Order 





DIAGNOSIS AND TESTING (Continued)**Symptom Chart****Symptom Chart**

Condition	Possible Sources	Action
<ul style="list-style-type: none"> • Difficult starting 	<ul style="list-style-type: none"> • Damaged ignition system. • Damaged fuel system. • Damaged starting system. • Damaged charging system/battery. • Burnt valve. • Worn piston. • Worn piston rings. • Worn cylinder. • Damaged head gasket. • Damaged cooling system. 	<ul style="list-style-type: none"> • Refer to the appropriate section in Group 303 for the procedure. REFER to the Powertrain Control/Emissions Diagnosis (PC/ED) manual ¹. • Refer to the appropriate section in Group 303 for the procedure. REFER to the Powertrain Control/Emissions Diagnosis (PC/ED) manual ¹. • Refer to the appropriate section in Group 303 for the procedure. REFER to the Powertrain Control/Emissions Diagnosis (PC/ED) manual ¹. • REFER to Section 414-00. • INSTALL a new valve. • INSTALL a new piston and piston head. • INSTALL a new piston ring. • REPAIR or INSTALL a new cylinder block. • INSTALL a new head gasket. • Refer to the appropriate section in Group 303 for the procedure. REFER to the Powertrain Control/Emissions Diagnosis (PC/ED) manual ¹.
<ul style="list-style-type: none"> • Poor idling 	<ul style="list-style-type: none"> • Vacuum leaks. • Malfunctioning or damaged ignition system. • Malfunctioning or damaged fuel system. • Damaged valve tappet or lash adjuster. • Damaged valve tappet guide or lash adjuster. • Incorrect valve-to-valve seat contact. • Damaged head gasket. 	<ul style="list-style-type: none"> • Refer to the appropriate section in Group 303 for the procedure. REFER to the Powertrain Control/Emissions Diagnosis (PC/ED) manual ¹. • Refer to the appropriate section in Group 303 for the procedure. REFER to the Powertrain Control/Emissions Diagnosis (PC/ED) manual ¹. • Refer to the appropriate section in Group 303 for the procedure. REFER to the Powertrain Control/Emissions Diagnosis (PC/ED) manual ¹. • INSTALL a new valve tappet or lash adjuster. • INSTALL a new valve tappet guide or valve tappet. • REPAIR or INSTALL a new valve or valve seat. • INSTALL a new head gasket.



BUY IT NOW!

Click Here To Order



DIAGNOSIS AND TESTING (Continued)**Symptom Chart (Continued)**

Condition	Possible Sources	Action
<ul style="list-style-type: none"> Abnormal combustion 	<ul style="list-style-type: none"> Malfunctioning or damaged fuel system. Malfunctioning or damaged ignition system. Malfunctioning or damaged air intake system. Damaged valve tappet or lash adjuster. Damaged valve tappet guide or valve tappet. Burnt or sticking valve. Weak or broken valve spring. Carbon accumulation in combustion chamber. 	<ul style="list-style-type: none"> Refer to the appropriate section in Group 303 for the procedure. REFER to the Powertrain Control/Emissions Diagnosis (PC/ED) manual ². Refer to the appropriate section in Group 303 for the procedure. REFER to the Powertrain Control/Emissions Diagnosis (PC/ED) manual ². Refer to the appropriate section in Group 303 for the procedure. REFER to the Powertrain Control/Emissions Diagnosis (PC/ED) manual ². INSTALL a new valve tappet or lash adjuster. INSTALL a new valve tappet guide or valve tappet. REPAIR or INSTALL a new valve. INSTALL a new valve spring. ELIMINATE carbon buildup.
<ul style="list-style-type: none"> Excessive oil consumption 	<ul style="list-style-type: none"> Leaking oil. Malfunctioning PCV system. Worn valve stem seal. Worn valve stem or valve guide. Sticking piston rings. Worn piston ring groove. Worn piston or cylinder. 	<ul style="list-style-type: none"> REPAIR oil leakage. REPAIR or INSTALL new necessary components. INSTALL a new valve stem seal. INSTALL a new valve and valve guide. REPAIR or INSTALL new piston rings. INSTALL a new piston and piston pin. REPAIR or INSTALL a new piston or cylinder block.



BUY IT NOW!

Click Here To Order



DIAGNOSIS AND TESTING (Continued)**Symptom Chart (Continued)**

Condition	Possible Sources	Action
<ul style="list-style-type: none"> Engine noise 	<ul style="list-style-type: none"> Leaking exhaust system. Incorrect drive belt tension. Malfunctioning generator bearing. Malfunctioning water pump bearing. Malfunctioning or damaged cooling system. Malfunctioning or damaged fuel system. Loose timing chain/belt (6268). Damaged timing chain tensioner (6L266). Excessive main bearing clearance. Seized or heat damaged crankshaft main bearing. Excessive crankshaft end play. Excessive connecting rod bearing clearance. Heat damaged connecting rod bearing (6211). Damaged connecting rod bushing (6207). Worn cylinder. Worn piston (6108) or piston pin (6135). Damaged piston rings. Bent connecting rod. Malfunctioning valve tappet (6500) or lash adjuster. Excessive valve tappet or lash adjuster clearance. Broken valve spring (6513). Excessive valve guide clearance. 	<ul style="list-style-type: none"> REPAIR exhaust leakage. REFER to Section 303-05. Refer to the appropriate section in Group 414 for the procedure. REFER to Section 303-03A. REFER to Section 303-03A. Refer to the appropriate section in Group 303 for the procedure. REFER to the Powertrain Control/Emissions Diagnosis (PC/ED) manual ³. ADJUST or INSTALL a new timing chain/belt. INSTALL a new timing chain tensioner. ADJUST clearance or INSTALL a new crankshaft main bearing (6333). INSTALL a new crankshaft main bearing. INSTALL a new thrust bearing or crankshaft (6303). INSTALL a new connecting rod bearing or connecting rod (6200). INSTALL a new connecting rod bearing. INSTALL a new connecting rod bushing. REPAIR or INSTALL a new cylinder block (6010). INSTALL a new piston or piston pin. INSTALL new piston rings. INSTALL a new connecting rod. INSTALL a new valve tappet or lash adjuster. ADJUST clearance or INSTALL a new valve tappet guide or valve tappet. INSTALL a new valve spring. ADJUST clearance or INSTALL a new valve guide (6510) and stem.



BUY IT NOW!

Click Here To Order



DIAGNOSIS AND TESTING (Continued)

Symptom Chart (Continued)

Condition	Possible Sources	Action
<ul style="list-style-type: none"> Insufficient power 	<ul style="list-style-type: none"> Malfunctioning or damaged ignition system. Malfunctioning or damaged fuel system. Malfunctioning or damaged air intake system. Damaged or plugged exhaust system. Incorrect tire size. Dragging brakes. Slipping transmission. Malfunctioning valve tappet or lash adjuster. Damaged valve tappet guide or valve tappet. Compression leakage at valve seat. Seized valve stem. Weak or broken valve spring. Worn or damaged cam. Damaged head gasket (6051). Cracked or distorted cylinder head. Damaged, worn or sticking piston ring(s). Worn or damaged piston. 	<ul style="list-style-type: none"> Refer to the appropriate section in Group 303 for the procedure. REFER to the Powertrain Control/Emissions Diagnosis (PC/ED) manual ⁴. Refer to the appropriate section in Group 303 for the procedure. REFER to the Powertrain Control/Emissions Diagnosis (PC/ED) manual ⁴. Refer to the appropriate section in Group 303 for the procedure. REFER to the Powertrain Control/Emissions Diagnosis (PC/ED) manual ⁴. INSPECT exhaust system. REFER to Section 204-04. REFER to Section 206-00. Refer to the appropriate section in Group 307 for the procedure. INSTALL a new valve tappet or lash adjuster. INSTALL a new valve tappet guide or valve tappet. REPAIR or INSTALL a new valve, valve seat or cylinder head (6049). INSTALL a new valve. INSTALL a new valve spring. INSTALL a new camshaft. INSTALL a new head gasket. INSTALL a new cylinder head. REPAIR or INSTALL a new piston ring(s). INSTALL a new piston and piston pin.

Component Tests

Engine Oil Leaks

NOTE: When diagnosing engine oil leaks, the source and location of the leak must be positively identified prior to repair.

Prior to carrying out this procedure, clean all sealing surface areas with a suitable solvent to remove all traces of oil.

Engine Oil Leaks—Fluorescent Oil Additive

1. Add gasoline engine oil dye. Use a minimum 14.8 ml (0.5 ounce) to a maximum 29.6 ml (1 ounce) of fluorescent additive to all engines. If the oil is not premixed, fluorescent additive must first be added to crankcase.
2. Run the engine for 15 minutes. Stop the engine and inspect all seal and gasket areas for leaks using the 12 Volt Master UV Diagnostic Inspection Kit. A clear bright yellow or orange area will identify the leak. For extremely small leaks, several hours may be required for the leak to appear.



BUY IT NOW!

Click Here To Order

UV Diagnostic Inspection Kit for oil leak



DIAGNOSIS AND TESTING (Continued)**Leakage Points—Underhood**

Examine the following areas for oil leakage:

- valve cover gaskets
- intake manifold gaskets
- cylinder head gaskets
- oil bypass filter
- oil filter adapter
- engine front cover
- oil filter adapter and filter body
- oil level indicator tube connection
- oil pressure sensor

Leakage Points—Under Engine—With Vehicle on Hoist

- oil pan gaskets (6710)
- oil pan sealer
- oil pan rear seal (6723)
- engine front cover gasket
- crankshaft front seal (6700)
- crankshaft rear oil seal (6701)
- crankshaft main bearing cap side bolts
- oil filter adapter and filter body
- oil cooler, if equipped

Leakage Points—With Transmission and Flywheel Removed

- crankshaft rear oil seal
- rear main bearing cap parting line
- rear main bearing cap and seals

- flywheel mounting bolt holes (with flywheel [6375] installed)
- camshaft rear bearing covers (6266) or pipe plugs at the end of oil passages

Oil leaks at crimped seams in sheet metal parts and cracks in cast or stamped parts can be detected when using the dye method.

Compression Test—Compression Gauge Check

1. Make sure the oil in the crankcase is of the correct viscosity and at the correct level and that the battery (10655) is correctly charged. Operate the vehicle until the engine is at normal operating temperature. Turn the ignition switch to the OFF position, then remove all the spark plugs (12405).
2. Set the throttle plates in the wide-open position.
3. Install a compression gauge such as the Compression Tester in the No. 1 cylinder.
4. Install an auxiliary starter switch in the starting circuit. With the ignition switch in the OFF position, and using the auxiliary starter switch, crank the engine a minimum of five compression strokes and record the highest reading. Note the approximate number of compression strokes required to obtain the highest reading.
5. Repeat the test on each cylinder, cranking the engine approximately the same number of compression strokes.

Compression Test—Test Results

The indicated compression pressures are considered within specification if the lowest reading cylinder is within 75 percent of the highest reading. Refer to the Compression Pressure Limit Chart.

Compression Pressure Limit Chart

Maximum Pressure	Minimum Pressure	Maximum Pressure	Minimum Pressure	Maximum Pressure	Minimum Pressure	Maximum Pressure	Minimum Pressure
924 kPa (134 psi)	696 kPa (101 psi)	1131 kPa (164 psi)	848 kPa (123 psi)	1338 kPa (194 psi)	1000 kPa (146 psi)	1544 kPa (224 psi)	1158 kPa (168 psi)
938 kPa (136 psi)	703 kPa (102 psi)	1145 kPa (166 psi)	855 kPa (124 psi)	1351 kPa (196 psi)	1014 kPa (147 psi)	1558 kPa (226 psi)	1165 kPa (169 psi)
952 kPa (138 psi)	717 kPa (104 psi)	1158 kPa (168 psi)	869 kPa (126 psi)	1365 kPa (198 psi)	1020 kPa (148 psi)	1572 kPa (228 psi)	1179 kPa (171 psi)
965 kPa (140 psi)	724 kPa (106 psi)	1172 kPa (170 psi)	876 kPa (127 psi)	1379 kPa (200 psi)	1034 kPa (150 psi)	1586 kPa (230 psi)	1186 kPa (172 psi)
979 kPa (142 psi)	731 kPa (107 psi)	1186 kPa (172 psi)	889 kPa (129 psi)	1393 kPa (202 psi)	1041 kPa (151 psi)	1600 kPa (232 psi)	1200 kPa (174 psi)



BUY IT NOW!

Click Here To Order



DIAGNOSIS AND TESTING (Continued)**Compression Pressure Limit Chart**

Maximum Pressure	Minimum Pressure	Maximum Pressure	Minimum Pressure	Maximum Pressure	Minimum Pressure	Maximum Pressure	Minimum Pressure
933 kPa (144 psi)	745 kPa (109 psi)	1200 kPa (174 psi)	903 kPa (131 psi)	1407 kPa (204 psi)	1055 kPa (153 psi)	1055 kPa (153 psi)	1207 kPa (175 psi)
1007 kPa (146 psi)	758 kPa (110 psi)	1214 kPa (176 psi)	910 kPa (132 psi)	1420 kPa (206 psi)	1062 kPa (154 psi)	1627 kPa (154 psi)	1220 kPa (177 psi)
1020 kPa (148 psi)	765 kPa (111 psi)	1227 kPa (178 psi)	917 kPa (133 psi)	1434 kPa (208 psi)	1075 kPa (156 psi)	1641 kPa (238 psi)	1227 kPa (178 psi)
1034 kPa (150 psi)	779 kPa (113 psi)	1241 kPa (180 psi)	931 kPa (135 psi)	1448 kPa (210 psi)	1083 kPa (157 psi)	1655 kPa (240 psi)	1241 kPa (180 psi)
1048 kPa (152 psi)	786 kPa (114 psi)	1255 kPa (182 psi)	936 kPa (136 psi)	1462 kPa (212 psi)	1089 kPa (158 psi)	1669 kPa (242 psi)	1248 kPa (181 psi)
1062 kPa (154 psi)	793 kPa (115 psi)	1269 kPa (184 psi)	952 kPa (138 psi)	1476 kPa (214 psi)	1103 kPa (160 psi)	1682 kPa (244 psi)	1262 kPa (183 psi)
1076 kPa (156 psi)	807 kPa (117 psi)	1282 kPa (186 psi)	965 kPa (140 psi)	1489 kPa (216 psi)	1117 kPa (162 psi)	1696 kPa (246 psi)	1269 kPa (184 psi)
1089 kPa (158 psi)	814 kPa (118 psi)	1296 kPa (188 psi)	972 kPa (141 psi)	1503 kPa (218 psi)	1124 kPa (163 psi)	1710 kPa (248 psi)	1202 kPa (186 psi)
1103 kPa (160 psi)	827 kPa (120 psi)	1310 kPa (190 psi)	979 kPa (142 psi)	1517 kPa (220 psi)	1138 kPa (165 psi)	1724 kPa (250 psi)	1289 kPa (187 psi)
1110 kPa (161 psi)	834 kPa (121 psi)	1324 kPa (192 psi)	993 kPa (144 psi)	1631 kPa (222 psi)	1145 kPa (166 psi)	—	—

If one or more cylinders reads low, squirt approximately one tablespoon of engine oil on top of the pistons in the low-reading cylinders. Repeat the compression pressure check on these cylinders.

Compression Test—Interpreting Compression Readings

1. If compression improves considerably, piston rings are faulty.
2. If compression does not improve, valves are sticking or seating incorrectly.
3. If two adjacent cylinders indicate low compression pressures and squirting oil on each piston does not increase compression, the head gasket may be leaking between cylinders. Engine oil or coolant in cylinders could result from this condition.

Use the Compression Pressure Limit Chart when checking cylinder compression so that the lowest reading is within 75 percent of the highest reading.

Cylinder Leakage Detection

When a cylinder produces a low reading, use of the Cylinder Leak Detection/Air Pressurization Kit is the correct cause.

The leakage detector is inserted in the spark plug hole, the piston is brought up to dead center on the compression stroke, and compressed air is admitted.

Once the combustion chamber is pressurized, a special gauge included in the kit will read the percentage of leakage. Leakage exceeding 20 percent is excessive.

While the air pressure is retained in the cylinder, listen for the hiss of escaping air. A leak at the intake valve (6507) will be heard in the throttle body (9E926). A leak at the exhaust valve (6505) can be heard at the tail pipe. Leakage past the piston rings will be audible at the positive crankcase ventilation (PCV) connection. If air is passing through a blown head gasket to an adjacent cylinder, the noise will be evident at the spark plug hole of the cylinder into which the air is leaking. Cracks in the cylinder block or gasket leakage into the cooling system may be detected by a stream of bubbles in the radiator (8005).

Oil Consumption Test

The following diagnostic procedure is used to determine the source of excessive internal oil consumption.



BUY IT NOW!

Click Here To Order



DIAGNOSIS AND TESTING (Continued)

1. **NOTE:** Oil use is normally greater during the first 16,100 km (10,000 miles) of service. As mileage increases, oil use generally decreases. Vehicles in normal service should get at least 1,450 km per liter (900 miles per quart) after 16,000 km (10,000 miles) of service. High speed driving, towing, high ambient temperature and other factors may result in greater oil use.
Define excessive oil consumption, such as the number of miles driven per liter (quart) of oil used. Also determine customer's driving habits, such as sustained high speed operation, towing, extended idle and other considerations.
2. Verify that the engine has no external oil leak as described under Engine Oil Leaks in the Diagnosis and Testing portion of this section.
3. Verify that the engine has the correct oil level dipstick (6750).
4. Verify that the engine is not being run in an overfilled condition. Check the oil level at least five minutes after a hot shutdown with the vehicle parked on a level surface. In no case should the level be above MAX or the letter F in FULL. If significantly overfilled, carry out Steps 6a through 6d.
5. Verify the spark plugs are not oil saturated. If the spark plugs are oil saturated and compression is good it can be assumed the valve seals or valve guides are at fault.
6. Carry out an oil consumption test:
 - a. Drain the engine oil, remove the oil bypass filter (6714) and refill with one liter (quart) less than the recommended amount.
 - b. Run the engine for three minutes (10 minutes if cold), and allow the oil to drain back for at least five minutes with the vehicle on a level surface.
 - c. Remove oil level dipstick and wipe clean. (Do not wipe with anything contaminated with silicone compounds.) Reinstall the oil level dipstick, being sure to seat it firmly in the oil level indicator tube (6754). Remove the oil level dipstick and draw a mark on the back (unmarked) surface at the indicated oil level. This level should be about the same as the MIN or ADD mark on the face of the oil
 - d. Add one liter (quart) of oil. Restart the engine and allow to idle for at least two minutes. Shut off the engine and allow the oil to drain back for at least five minutes. Mark the oil level dipstick, using the procedure above.
 - e. Record the vehicle mileage.
 - f. Instruct the customer to drive the vehicle as usual and perform the following:
 - Check the oil level regularly at intervals of 160 to 240 km (100-150 miles).
 - Return to the service point when the oil level drops below the lower (MIN or ADD) mark on the oil level dipstick.
 - Add only full liters (quarts) of the same oil in an emergency. Note the mileage at which the oil is added.
 - g. Check the oil level under the same conditions and at the same location as in Steps 6c and 6d.
 - Measure the distance from the oil level to the UPPER mark on the oil level dipstick and record.
 - Measure the distance between the two scribe marks and record.
 - Divide the first measurement by the second.
 - Divide the distance driven during the oil test by the result. This quantity is the approximate oil consumption rate in kilometers per liter or in miles per quart.
 - h. If the oil consumption rate is unacceptable, go to Step 7.
7. Check the positive crankcase ventilation (PCV) system. Make sure the system is not plugged.
8. Check for plugged oil drain-back holes in the cylinder heads and cylinder block.
9. If the condition still exists after performing the above steps, go to Step 10.
10. Perform a cylinder compression test or perform a cylinder leak detection test with Engine Cylinder Leak Detection/Air Pressurization Kit. This can help determine the source of oil consumption such as valves, piston rings or other areas.



BUY IT NOW!

Click Here To Order



DIAGNOSIS AND TESTING (Continued)

11. **NOTE:** After determining if new parts should be installed, make sure correct parts are used.
- Check valve guides for excessive guide clearance. Install new all valve stem seals (6571) after verifying valve guide clearance.
12. Worn or damaged internal engine components can cause excessive oil consumption. Small deposits of oil on the tips of spark plugs can be a clue to internal oil consumption. If internal oil consumption still persists, proceed as follows:
- Remove the engine from the vehicle and place it on an engine work stand. Remove the intake manifolds (9424), cylinder heads, oil pan (6675) and oil pump (6600).
 - Check piston ring clearance, ring gap and ring orientation. Repair as necessary.
 - Check for excessive bearing clearance. Repair as necessary.
13. Repeat the oil consumption test (Step 6) to confirm the oil consumption concern has been resolved.

Intake Manifold Vacuum Test

Bring the engine to normal operating temperature. Connect the Vacuum/Pressure Tester to the intake manifold. Run the engine at the specified idle speed.

The vacuum gauge should read between 51-74 kPa (15-22 in-Hg) depending upon the engine condition and the altitude at which the test is performed. Subtract 4.0193 kPa (1 in-Hg) from the specified reading for every 304.8 m (1,000 feet) of elevation above sea level.

The reading should be steady. If necessary, adjust the gauge damper control (where used) if the needle is fluttering rapidly. Adjust the damper until the needle moves easily without excessive flutter.

Intake Manifold Vacuum Test—Interpreting Vacuum Gauge Readings

A careful study of the vacuum gauge reading while the engine is idling will help pinpoint trouble areas. Always conduct other appropriate tests before arriving at a final diagnostic decision. Vacuum gauge readings, although helpful, must be interpreted carefully.

Most vacuum gauges have a normal band indicated on the gauge face.

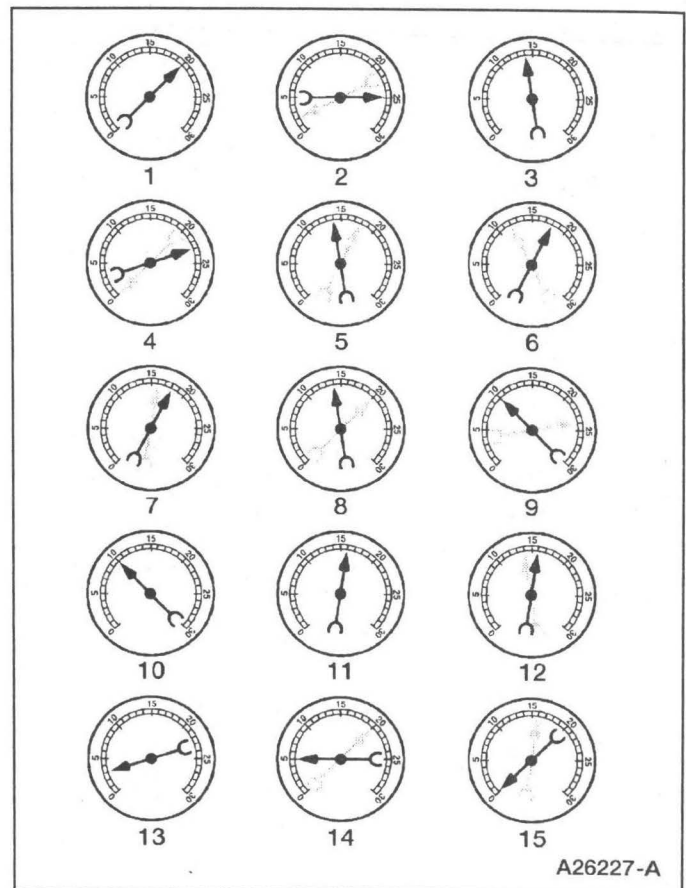

- NORMAL READING:** Needle between 51-74 kPa (15-22 in-Hg) and holding steady.
- NORMAL READING DURING RAPID ACCELERATION AND DECELERATION:** When the engine is rapidly accelerated (dotted needle), the needle will drop to a low reading (not to zero). When the throttle is suddenly released, the needle will snap back up to a higher than normal figure.
- NORMAL FOR HIGH-LIFT CAMSHAFT WITH LARGE OVERLAP:** The needle will register as low as 51 kPa (15 in-Hg) but will be relatively steady. Some oscillation is normal.
- WORN RINGS OR DILUTED OIL:** When the engine is accelerated (dotted needle), the needle drops to 0 kPa (0 in-Hg). Upon deceleration, the needle runs slightly above 74 kPa (22 in-Hg).
- STICKING VALVES:** When the needle (dotted) remains steady at a normal vacuum but occasionally flicks (sharp, fast movement) down and back about 13 kPa (4 in-Hg), one or more valves may be sticking.



BUY IT NOW!

[Click Here To Order](#)



DIAGNOSIS AND TESTING (Continued)

6. **BURNED OR WARPED VALVES:** A regular, evenly-spaced, downscale flicking of the needle indicates one or more burned or warped valves. Insufficient hydraulic lash adjuster or hydraulic lash adjuster (HLA) clearance will also cause this reaction.
7. **POOR VALVE SEATING:** A small but regular downscale flicking can mean one or more valves are not seating.
8. **WORN VALVE GUIDES:** When the needle oscillates over about a 13 kPa (4 in-Hg) range at idle speed, the valve guides could be worn. As engine speed increases, the needle will become steady if guides are responsible.
9. **WEAK VALVE SPRINGS:** When the needle oscillation becomes more violent as engine rpm is increased, weak valve springs are indicated. The reading at idle could be relatively steady.
10. **LATE VALVE TIMING:** A steady but low reading could be caused by late valve timing.
11. **IGNITION TIMING RETARDING:** Retarded ignition timing will produce a steady but somewhat low reading.
12. **INSUFFICIENT SPARK PLUG GAP:** When spark plugs are gapped too close, a regular, small pulsation of the needle can occur.
13. **INTAKE LEAK:** A low, steady reading can be caused by an intake manifold or throttle body gasket leak.
14. **BLOWN HEAD GASKET:** A regular drop of fair magnitude can be caused by a blown head gasket or warped cylinder head-to-cylinder block surface.
15. **RESTRICTED EXHAUST SYSTEM:** When the engine is first started and is idled, the reading may be normal, but as the engine rpm is increased, the back pressure caused by a clogged muffler (5230), kinked tail pipe or other concerns will cause the needle to slowly drop to 0 kPa (0 in-Hg). The needle then may slowly rise. Excessive exhaust clogging will cause the needle to drop to a low point even if the engine is only idling.
16. When vacuum leaks are indicated, search out and correct the cause. Excess air leaking into the system will upset the fuel mixture and cause concerns such as rough idle, missing on

s. If the leak exists in power brake booster
tion correctly.

Excessive Engine Oil Consumption

The amount of oil an engine uses will vary with the way the vehicle is driven in addition to normal engine-to-engine variation. This is especially true during the first 16,100 km (10,000 miles) when a new engine is being broken in or until certain internal engine components become conditioned. Vehicles used in heavy-duty operation may use more oil. The following are examples of heavy-duty operation:

- trailer towing applications
- severe loading applications
- sustained high speed operation

Engines need oil to lubricate the following internal components:

- cylinder block cylinder walls
- pistons and piston, pin and rings (6102)
- intake and exhaust valve stems
- intake and exhaust valve guides
- all internal engine components

When the pistons move downward, a thin film of oil is left on the cylinder walls. As the vehicle is operated, some oil is also drawn into the combustion chambers past the intake and exhaust valve stem seals and burned.

The following is a partial list of conditions that can affect oil consumption rates:

- engine duty cycle
- operator driving habits
- ambient temperature
- quality and viscosity of the oil

Operation under varying conditions can frequently be misleading. A vehicle that has been run for several thousand miles on short trips or in below-freezing ambient temperatures may have consumed a “normal” amount of oil. However, when checking the engine oil level, it may measure up to the FULL or MAX on the oil level dipstick due to dilution (condensation and fuel) in the engine crankcase. The vehicle might then be driven at high speeds on the highway where the condensation and fuel boil off. The next time the engine oil is checked, it may appear that a liter (quart) of oil was used in about 160 km (100 miles). This perceived 160 km (100 miles) per liter (quart) oil consumption rate causes customer concern even though the actual overall oil consumption rate is about 2,400 km (1,500 miles) per liter (quart).



BUY IT NOW!

Click Here To Order



DIAGNOSIS AND TESTING (Continued)

Make sure the selected engine oil meets the current recommended API performance category with SAE viscosity grade as shown in the vehicle Owner's Guide. It is also important that the engine oil is changed at the intervals specified. Refer to the vehicle Owner's Guide.

Oil Pressure Test

1. Disconnect and remove the oil pressure sensor (9278) from the engine.
2. Connect the Engine Oil Pressure Gauge to the oil pressure sender oil galley port.
3. Run the engine until normal operating temperature is reached.
4. Run the engine at the specified rpm and record the gauge reading.
5. The oil pressure should be within specifications; refer to the specification chart in the appropriate engine section.
6. If the pressure is not within specification, check the following possible sources:
 - insufficient oil
 - oil leakage
 - worn or damaged oil pump
 - oil pump screen cover and tube (6622)
 - excessive main bearing clearance
 - excessive connecting rod bearing clearance

Valve Train Analysis—Engine Off—Valve Cover Removed

Check for damaged or severely worn parts and correct assembly. Make sure correct parts are used with the static engine analysis as follows.

Valve Train Analysis—Engine Off, Rocker Arm

- Check for loose mounting bolts, studs and nuts.
- Check for plugged oil feed in the rocker arms (6564) or cylinder head.

Valve Train Analysis—Engine Off, Camshaft Roller Followers and Hydraulic Lash Adjusters, Overhead Camshaft

- Check for loose mounting bolts on camshaft carriers.
- Check for plugged oil feed in the camshaft roller followers and cylinder heads.

Valve Train Analysis—Engine Off, Camshaft—Engines

- Check for broken or damaged parts.

Valve Train Analysis—Engine Off, Push Rods

- Check for bent push rods (6565) and restricted oil passage.

Valve Train Analysis—Valve Springs

- Check for broken or damaged parts.

Valve Train Analysis—Engine Off, Valve Spring Retainer and Valve Spring Retainer Keys

- Check for correct seating of the valve spring retainer key (6518) on the valve stem and in valve spring retainer (6514).
- Check for correct seating on the valve stem.

Valve Train Analysis—Engine Off, Valves and Cylinder Head

- Check for plugged oil drain back holes.
- Check for worn or damaged valve tips.
- Check for missing or damaged guide-mounted valve stem seal.
- Check collapsed valve tappet gap.
- Check installed valve spring height.
- Check for missing or worn valve spring seats.
- Check for plugged oil metering orifice in cylinder head oil reservoir (if equipped).

Static checks (engine off) are to be made on the engine prior to the dynamic procedure.

Valve Train Analysis—Engine Running

- Start the engine and, while idling, check for correct operation of all parts. Check the following:

Valve Train Analysis—Engine Running, Valves and Cylinder Head

- Check for plugged oil drain back holes.
- Check for missing or damaged valve stem seals or guide mounted valve stem seals.
- Check for a plugged oil metering orifice in the cylinder head oil reservoir (4.6L engine only).



BUY IT NOW!

Click Here To Order



DIAGNOSIS AND TESTING (Continued)

If insufficient oiling is suspected, check oil passages for blockage, then accelerate the engine to 1,200 rpm with the transmission in NEUTRAL and the engine at normal operating temperature. Oil should spurt from the rocker arm oil holes such that valve tips and camshaft roller followers are well oiled. With the valve covers (6582) off, some oil splash may overshoot camshaft roller followers.

Valve Train Analysis—Engine Running, Camshaft Lobe Lift—OHC Engines

Check the lift of each camshaft lobe in consecutive order and make a note of the readings.

1. Remove the valve covers.
2. Remove the spark plugs.
3. Install the Dial Indicator with Bracketry so the rounded tip of indicator is on top of the camshaft lobe and on the same plane as the valve tappet.
4. Rotate the crankshaft using a breaker bar and socket attached to the crankshaft pulley retainer bolt. Rotate the crankshaft until the base circle of the camshaft lobe is reached.

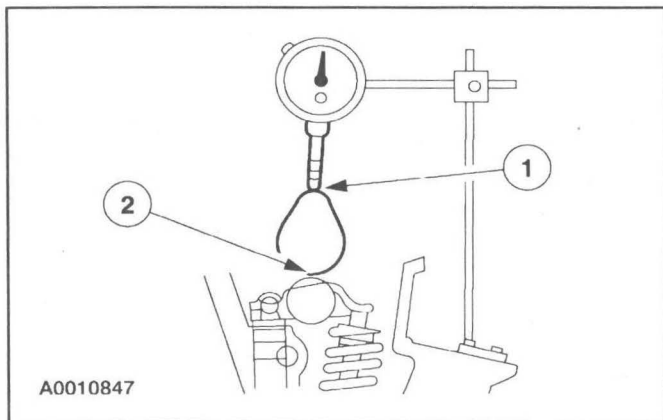

5. Zero the dial indicator. Continue to rotate the crankshaft until the (1) high-lift point of the camshaft lobe is in the fully-raised position (highest indicator reading).
6. To check the accuracy of the original indicator reading, continue to rotate crankshaft until the (2) base circle is reached. The indicator reading should be zero. If zero reading is not obtained, repeat Steps 1 through 6.
7. **NOTE:** If the lift on any lobe is below specified service limits, install a new camshaft, and new

9. Install the valve covers.

Valve Train Analysis—Engine Running, Camshaft Lobe Lift—Push Rod Engine

Check the lift of each lobe in consecutive order and make a note of the readings.

1. Remove the valve covers.
2. Remove the rocker arm seat bolts, rocker arm seat (6A528) and rocker arms.

Typical Engine With Push Rods

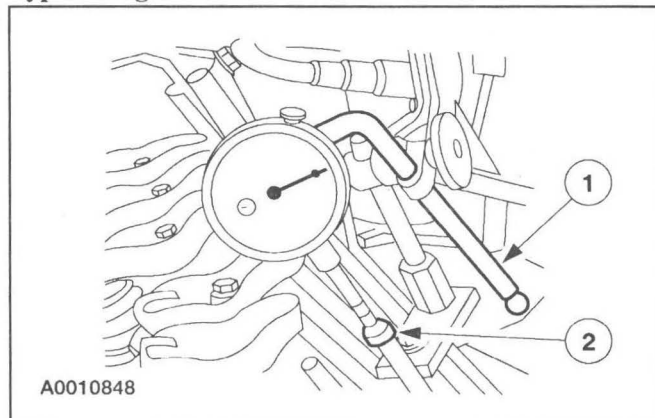

3. Make sure the valve tappet is seated against camshaft (6250). Install (1) Dial Indicator with Bracketry so the ball socket adapter of the indicator is on top of the valve tappet or (2) Cup Shaped Adapter is on top of push rod and in same plane as valve tappet push rod movement.
4. Remove the spark plugs.
5. Connect an auxiliary starter switch in the starting circuit. Crank the engine with ignition switch in OFF position. Bump crankshaft over until valve tappet is on base circle of camshaft lobe. At this point, valve tappet will be in its lowest position. If checking during engine assembly, turn crankshaft using a socket or ratchet.
6. Zero the dial indicator. Continue to rotate crankshaft slowly until valve tappet is in fully-raised position (highest indicator reading).
7. **NOTE:** If lift on any lobe is below specified service limits, install a new camshaft, and new valve tappets.

Remove the Dial Indicator with Bracketry, adapter, and auxiliary starter switch.

8. Install rocker arm seats, rocker arms and rocker arm seat bolts.
9. Install valve covers.



BUY IT NOW!

Click Here To Order

with Bracketry.



DIAGNOSIS AND TESTING (Continued)

10. Install spark plugs.

Valve Train Analysis—Engine Running, Valve Tappet

Valve tappet noise can be caused by any of the following:

- excessive valve tappet gap (collapsed)
- incorrectly functioning valve tappet
- air in lubrication system
- excessive valve guide wear
- low oil pressure

Excessive collapsed valve tappet gap can be caused by loose rocker arm seat bolts/nuts, incorrect initial adjustment or wear of valve tappet face, or worn roller valve tappets, push rod (6565), rocker arm (6564), rocker arm seat or valve tip. With valve tappet collapsed, check gap between the valve tip and the rocker arm to determine if any other valve train parts are damaged, worn or out of adjustment.

An incorrectly functioning valve tappet can be sticking, caused by contaminants or varnish inside the tappet. The tappet can have a check valve that is not functioning correctly, which can be caused by an obstruction, such as dirt or chips that prevent the check valve from closing, or a broken check valve spring. A tappet with a leakdown time out of specification can cause tappet noise. If no other cause for noisy valve tappets can be found, the leakdown rate should be checked and new valve tappets installed if found to be out of specification.

Assembled valve tappets can be tested with Hydraulic Tappet Leakdown Tester to check the leakdown rate. The leakdown rate specification is the time in seconds for the plunger to move a specified distance while under a 22.7 kg (50 lb) load.

Air bubbles in the lubrication system will prevent the valve tappet from supporting the valve spring load. This can be caused by too high or too low an oil level in the oil pan or by air being drawn into the system through a hole, crack or leaking gasket on the oil pump screen cover and tube.



100% SATISFACTION GUARANTEED

BUY IT NOW!

Click Here To Order

PayPal American Express Discover MasterCard VISA

GENERAL PROCEDURES

Sprockets

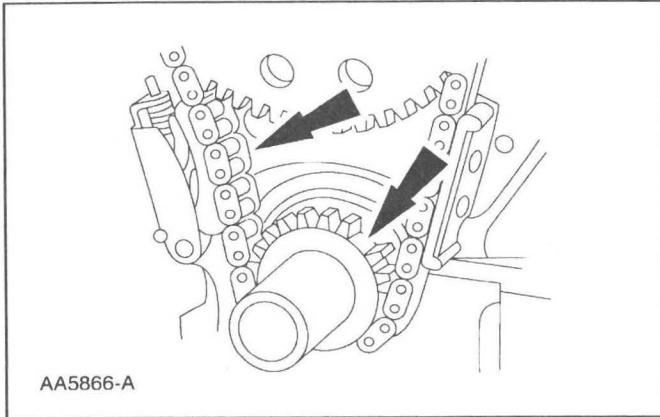

1. **⚠ WARNING:** To avoid the possibility of personal injury or damage to the vehicle, do not operate the engine with the hood open until the fan blade has been examined for possible cracks and separation.

NOTE: Specifications show the expected minimum or maximum condition. Refer to the appropriate section in Group 303 for the procedure.

NOTE: If a component fails to meet the specifications, it is necessary to install a new component or refinish. If the component can be refinished, wear limits are provided as an aid to making a decision. A new component must be installed for any component that fails to meet specifications and cannot be refinished.

Inspect the timing chain/belt and the sprockets.

- Install new components as necessary. Refer to the appropriate section in Group 303 for the procedure.

Rocker Arms —Cleaning

1. Clean all parts thoroughly. Make sure all oil passages are open.
2. Make sure oil passage in the push rod/valve tappet end of the rocker arm (6564) is open.

100% SATISFACTION GUARANTEED

BUY IT NOW!

Click Here To Order

GENERAL PROCEDURES (Continued)

Rocker Arms — Inspection

⚠ CAUTION: Do not attempt to true surfaces by grinding. Check the rocker arm pad, side rails and seat for excessive wear, cracks, nicks or burrs. Check the rocker arm seat bolt for stripped or broken threads. Install new components as necessary or possible damage may occur.

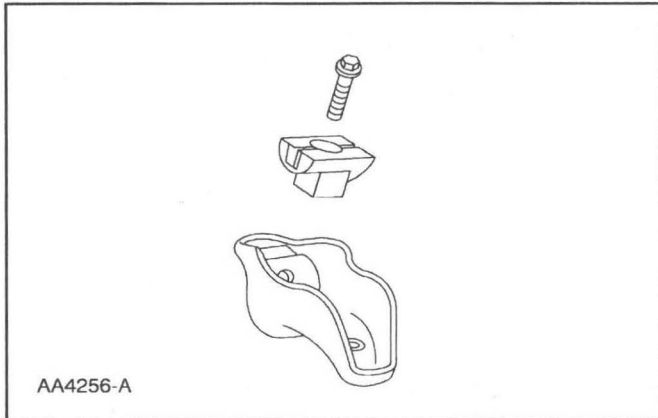

1. Inspect the rocker arm push rod bore for nicks, scratches, scores or scuffs. Install new components as necessary. Refer to the appropriate section in Group 303 for the procedure.
2. Inspect the pad at the valve end of the rocker arm for indications of scuffing or abnormal wear. If the pad is grooved, install a new rocker arm. Refer to the appropriate section in Group 303 for the procedure.

Push Rods — Cleaning

1. Clean the push rods (6565) in a suitable solvent. Blow out the oil passage in the push rods with compressed air.

Push Rods — Inspection

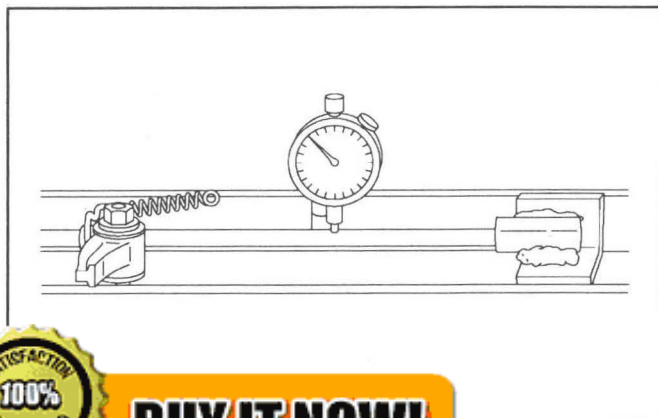

1. **⚠ CAUTION:** Do not attempt to straighten push rods.
Check the ends of the push rods for nicks, grooves, roughness or excessive wear. Install new push rods as necessary. Refer to the appropriate section in Group 303 for the procedure.
 - The push rods can be checked for straightness while they are installed in the engine by rotating them with the valve closed.
 - They also can be checked using a Dial Indicator with Bracketry.



BUY IT NOW!

Click Here To Order



GENERAL PROCEDURES (Continued)

2. If the push rod is bent beyond specifications, install a new push rod. Refer to the appropriate section in Group 303 for the procedure.

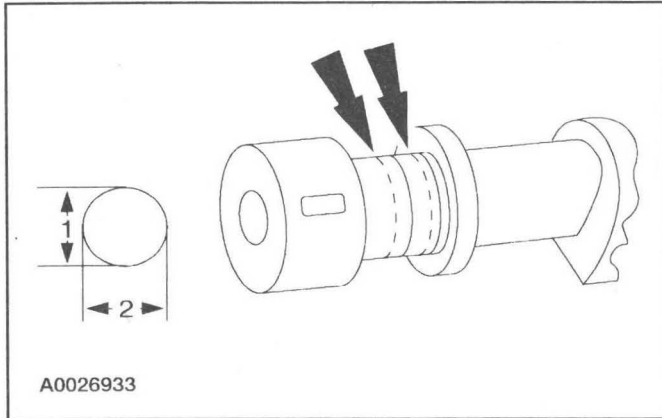
Camshaft Journal — Diameter

1. Measure each camshaft journal diameter in two directions.
 - If out of specification, install new components as necessary. Refer to the appropriate section in Group 303 for the procedure.

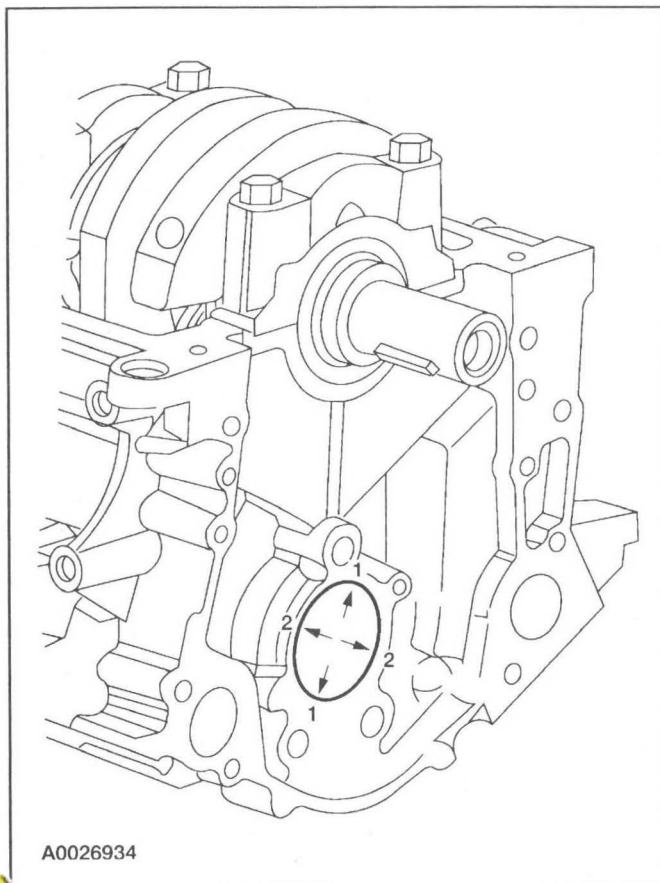
Camshaft Journal — Clearance, Push Rod Engines, Micrometer Method

1. **NOTE:** The camshaft journals must meet specifications before checking camshaft journal clearance. Measure each camshaft bearing (6261) in two directions.
 - Subtract the camshaft journal diameter from the camshaft bearing diameter.

**BUY IT NOW!****Click Here To Order**

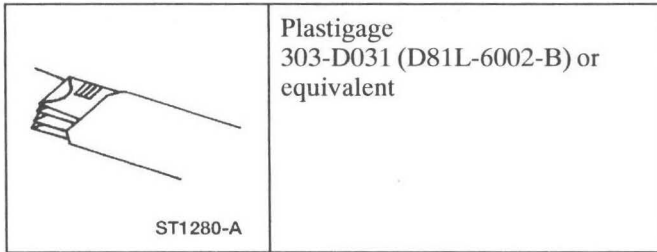
GENERAL PROCEDURES (Continued)**Camshaft Journal — Clearance, Plastigage Method****Special Tool(s)**

NOTE: The camshaft journals must meet specifications before checking camshaft journal clearance.

1. Remove the camshaft bearing cap and lay Plastigage across the surface. Refer to the appropriate section in Group 303 for the procedure.
2. **NOTE:** Do not turn the camshaft while carrying out this procedure.
Position the camshaft bearing cap and install the bolts. Refer to the appropriate section in Group 303 for the procedure.

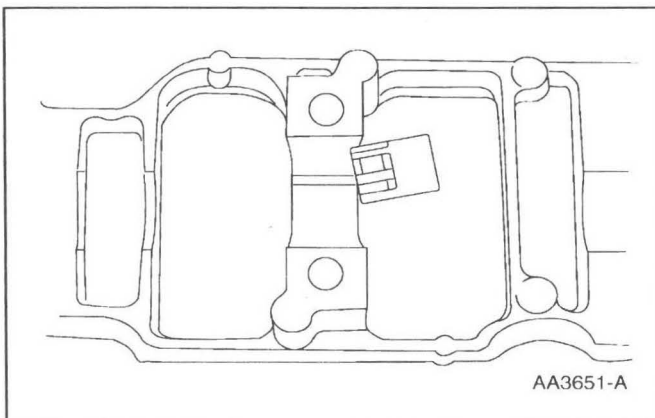

3. Use Plastigage to verify the camshaft journal clearance.
 - If out of specification, install new components as necessary. Refer to the appropriate section in Group 303 for the procedure.

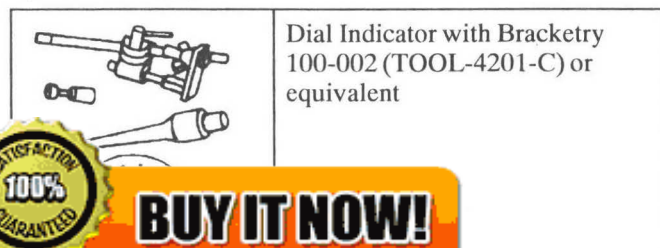
Camshaft — End Play Push Rod Engines**Special Tool(s)**

BUY IT NOW!

Click Here To Order



GENERAL PROCEDURES (Continued)

1. Remove the valve tappets. Refer to the appropriate section in Group 303 for the procedure.
2. Use a Dial Indicator with Bracketry to measure camshaft end play.
3. Position the camshaft to the rear of the cylinder block.
4. Zero the indicator.
5. Move the camshaft to the front of the cylinder block. Note and record the camshaft end play.
 - If the camshaft end play exceeds specifications, install a new camshaft thrust plate. Refer to the appropriate section in Group 303 for the procedure.

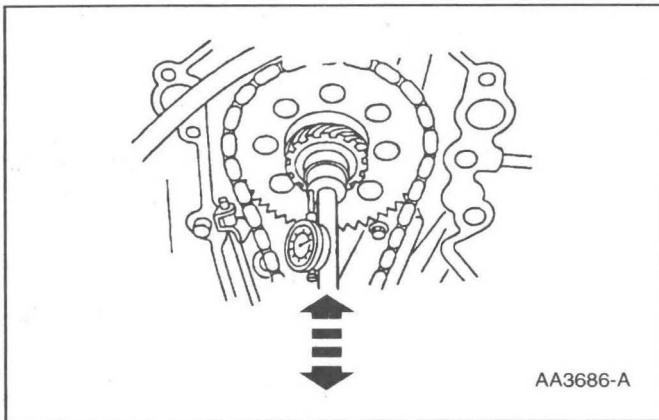
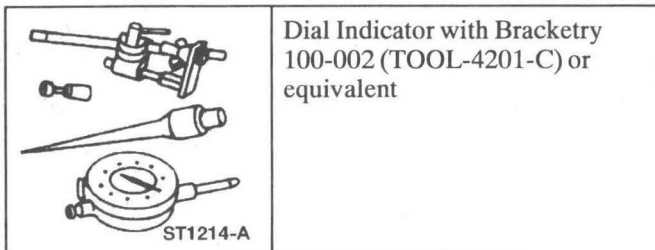
**Camshaft —End Play, OHC Engines****Special Tool(s)**

1. Remove the roller followers. Refer to the appropriate section in Group 303 for the procedure.
2. Use a Dial Indicator with Bracketry to measure camshaft end play.
3. Position the camshaft to the rear of the cylinder head.
4. Zero the indicator.

**BUY IT NOW!****Click Here To Order**

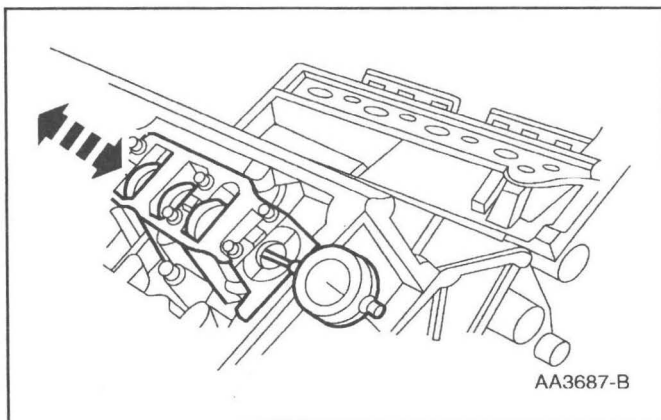
GENERAL PROCEDURES (Continued)

5. Move the camshaft to the front of the cylinder head. Note and record the camshaft end play.
 - If camshaft end play exceeds specifications, install new camshaft and recheck end play. Refer to the appropriate section in Group 303 for the procedure.
 - If camshaft end play exceeds specification after camshaft installation, install a new cylinder head. Refer to the appropriate section in Group 303 for the procedure.

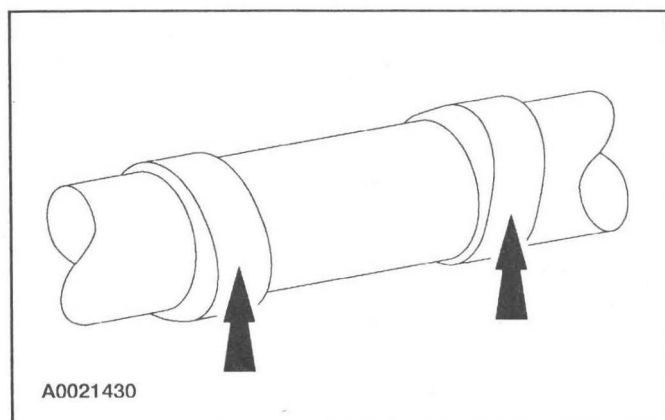
Camshaft —Lobe Surface

1. Inspect camshaft lobes for pitting or damage in the contact area. Minor pitting is acceptable outside the contact area.
 - If excessive pitting or damage is present, install new components as necessary. Refer to the appropriate section in Group 303 for the procedure.

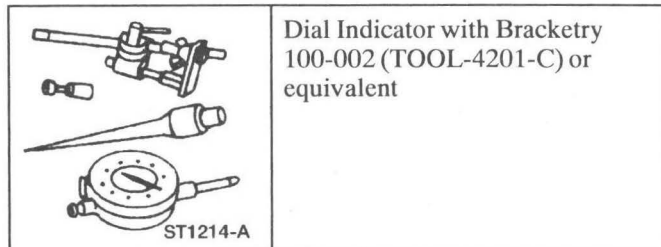
Camshaft —Lobe Lift**Special Tool(s)**

1. Use a Dial Indicator with Bracketry to measure camshaft intake/exhaust lobe lift.
 - Rotate the camshaft and subtract the lowest indicator reading from the highest indicator reading to figure the camshaft lobe lift.
 - For additional information, refer to Specifications in the appropriate section in Group 303.

**BUY IT NOW!****Click Here To Order**

GENERAL PROCEDURES (Continued)

Camshaft — Runout

Special Tool(s)

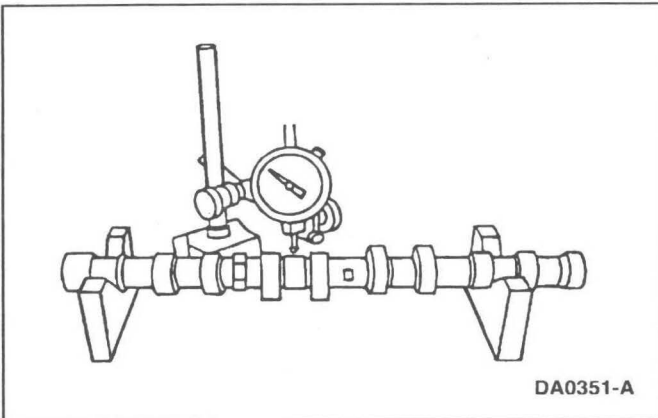
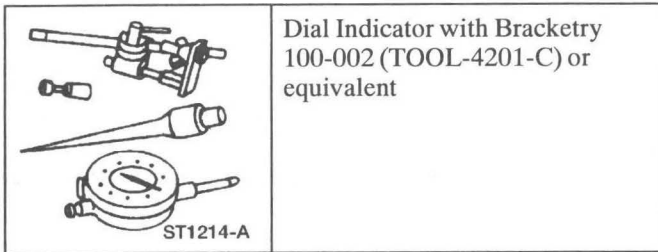

- NOTE:** Camshaft journals must be within specifications before checking runout.

Use a Dial Indicator with Bracketry to measure the camshaft runout.

 - Rotate the camshaft and subtract the lowest indicator reading from the highest indicator reading.
 - For additional information, refer to the specification chart in the appropriate engine section.
 - If out of specification, install new components as necessary. Refer to the appropriate section in Group 303 for the procedure.

Crankshaft Main Bearing Journal — Diameter

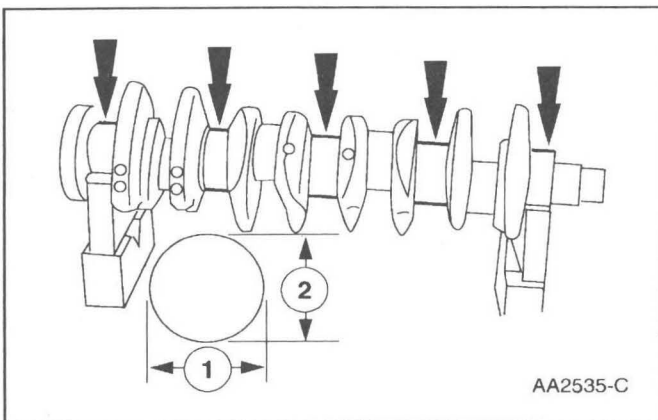

- Measure each of the crankshaft main bearing journal diameters in at least two directions.

 - For additional information, refer to Specifications in the appropriate section in Group 303.
 - If out of specification, install new components as necessary. Refer to the appropriate section in Group 303 for the procedure.

100% SATISFACTION GUARANTEED

BUY IT NOW!

Click Here To Order

GENERAL PROCEDURES (Continued)

Crankshaft Main Bearing Journal —Taper

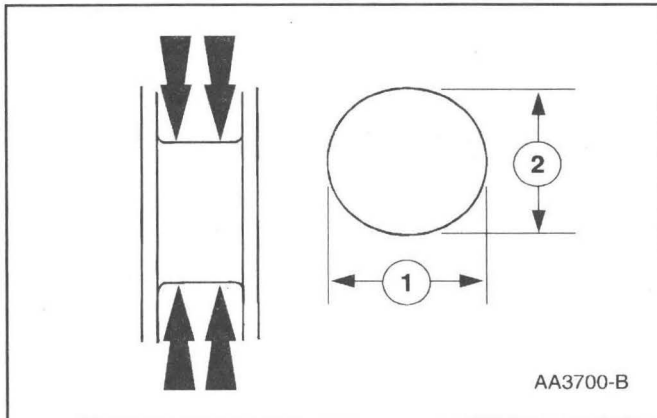

1. Measure each of the crankshaft main bearing journal diameters in at least two directions at each end of the main bearing journal.
 - For additional information, refer to Specifications in the appropriate section in Group 303.
 - If out of specification, install new components as necessary. Refer to the appropriate section in Group 303 for the procedure.

Crankshaft Main Bearing Journal —Clearance

Special Tool(s)

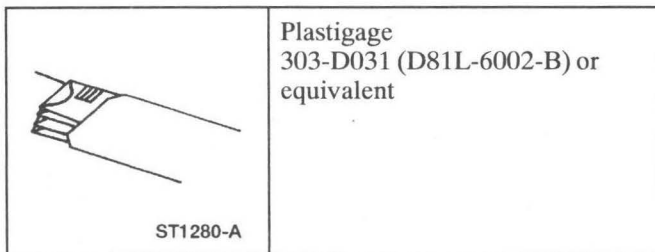

NOTE: Crankshaft main bearing journals must be within specifications before checking journal clearance.

1. Remove the crankshaft main bearing caps and crankshaft main bearing.
2. Lay a piece of Plastigage across the face of each crankshaft main bearing surface.

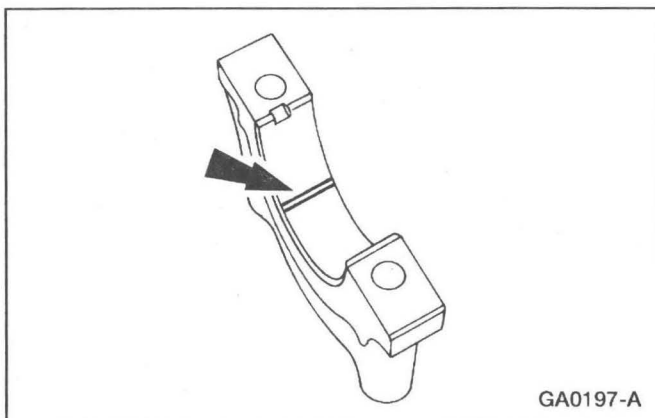

3. **NOTE:** Do not turn the crankshaft while carrying out this procedure.
Install and remove the crankshaft main bearing cap.

100% SATISFACTION GUARANTEED

BUY IT NOW!

Click Here To Order

GENERAL PROCEDURES (Continued)

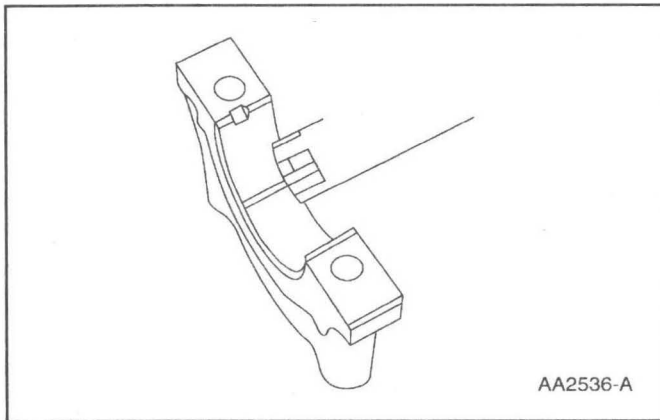

Crankshaft — End Play

Special Tool(s)

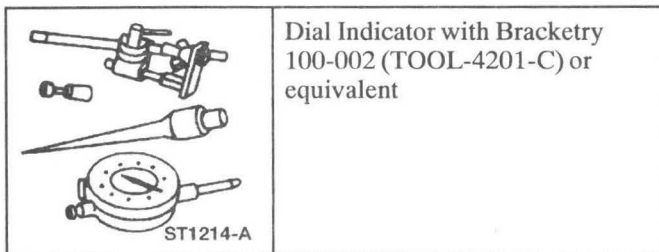

4. Verify the crankshaft journal clearance.
 - For additional information, refer to Specifications in the appropriate section in Group 303.
 - If out of specification, install new components as necessary. Refer to the appropriate section in Group 303 for the procedure.

1. Measure the crankshaft end play. Use a Dial Indicator with Bracketry to measure crankshaft end play.
2. Position the crankshaft to the rear of the cylinder block.
3. Zero the indicator.
4. Move the crankshaft to the front of the cylinder block. Note and record the crankshaft end play.
 - If crankshaft end play exceeds specifications, install a new crankshaft thrust washer (6334) or crankshaft thrust main bearing (6337). Refer to the appropriate section in Group 303 for the procedure.

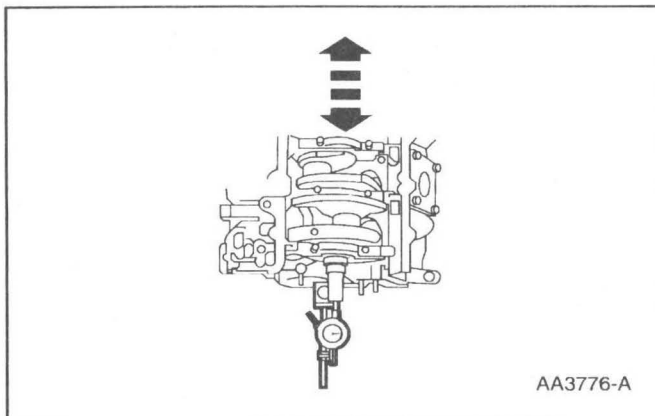

BUY IT NOW!

Click Here To Order



GENERAL PROCEDURES (Continued)

Crankshaft — Runout

Special Tool(s)

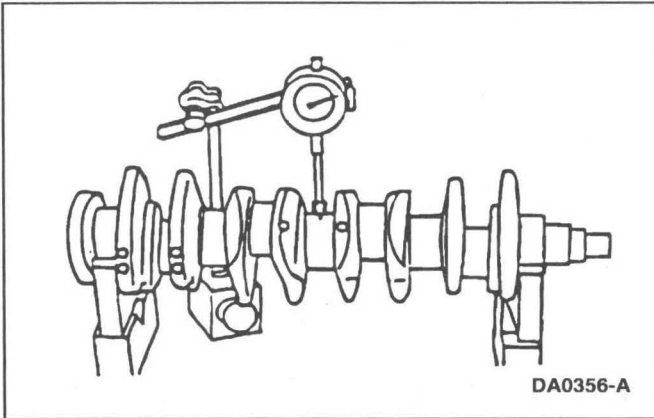
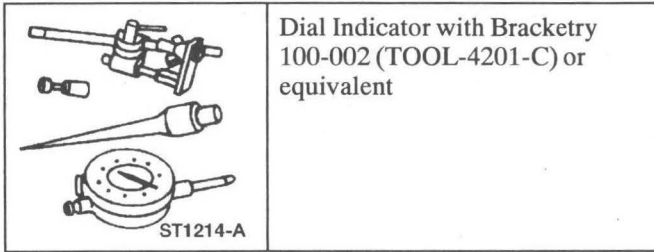

- NOTE:** Crankshaft main bearing journals must be within specifications before checking runout.

Use the Dial Indicator with Bracketry to measure the crankshaft runout.

- For additional information, refer to Specifications in the appropriate section in Group 303.
- Rotate the crankshaft and subtract the lowest dial indicator reading from the highest dial indicator reading to figure the crankshaft runout. If it is out of specification, install new components as necessary. Refer to the appropriate section in Group 303 for the procedure.

Crankshaft — Connecting Rod Journal Taper, Out of Round

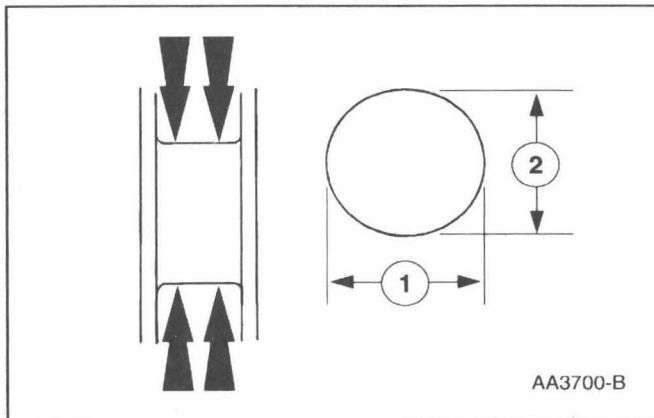

- Measure the crankshaft connecting rod journal diameters in two directions perpendicular to one another at each end of the connecting rod journal. The difference in the measurements from one end to the other is the taper. Verify measurement is within the wear limit.

- For additional information, refer to Specifications in the appropriate section in Group 303.
- If out of specification, install new components as necessary. Refer to the appropriate section in Group 303 for the procedure.

100% SATISFACTION GUARANTEED

BUY IT NOW!

Click Here To Order

PayPal Discover NOWUS MasterCard VISA

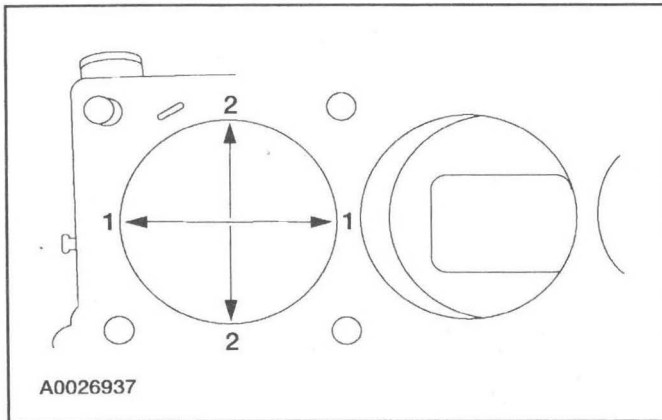
GENERAL PROCEDURES (Continued)**Cylinder Bore — Taper**

1. Measure the cylinder bore at the top, middle, and bottom of piston ring travel in two directions as indicated. Verify the cylinder bore is within the wear limit. The difference indicates the cylinder bore taper. Bore the cylinder to the next oversize.
 - For additional information, refer to Specifications in the appropriate section in Group 303.

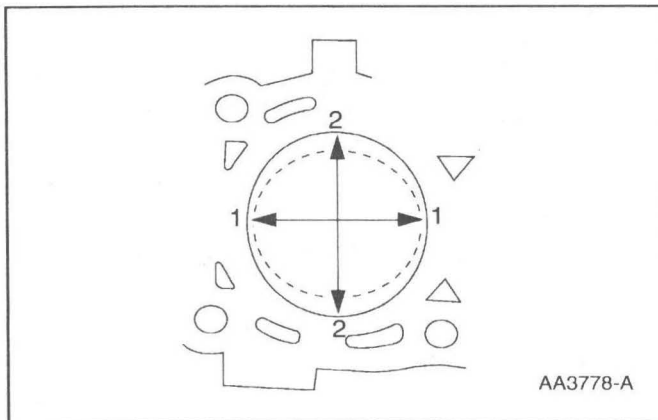
Cylinder Bore — Out-of-Round

1. Measure the cylinder bore in two directions. The difference is the out-of-round. Verify the out-of-round is within the wear limit and bore the cylinder to the next oversize limit.
 - For additional information, refer to Specifications in the appropriate section in Group 303.

Piston — Inspection**Special Tool(s)**

<p>ST1279-A</p>	<p>Piston Ring Groove Cleaner 303-D033 (D81L-6002-D) or equivalent</p>
-----------------	--

**BUY IT NOW!****Click Here To Order**

GENERAL PROCEDURES (Continued)

⚠ CAUTION: Do not use a caustic cleaning solution or a wire brush to clean the pistons or damage can occur.

1. Clean and inspect the (1) ring lands, (2) skirts, (3) pin bosses, and the (4) tops of the pistons. If wear marks, scores or glazing is found on the piston skirt, check for a bent or twisted connecting rod.

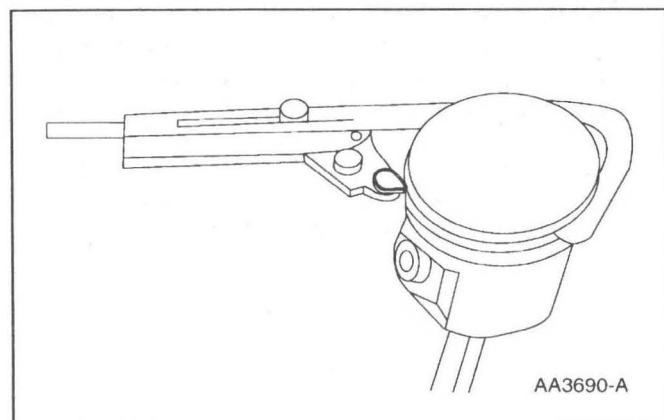
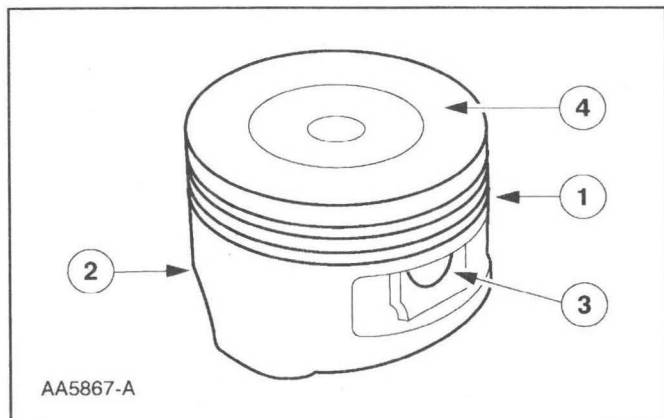

2. Use the Piston Ring Groove Cleaner to clean the piston ring grooves.
 - Make sure the oil ring holes are clean.

Piston — Pin to Bore Diameter

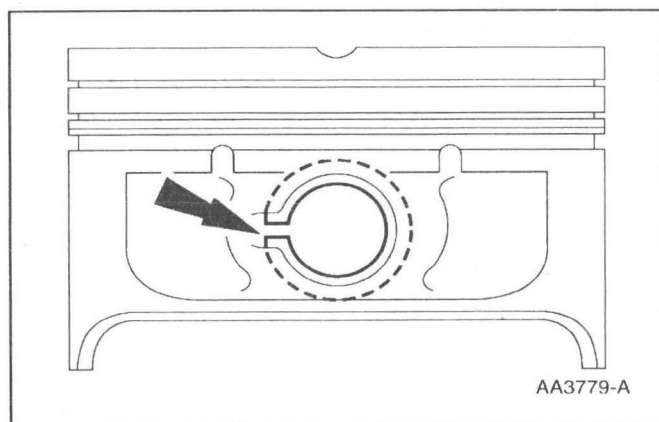

1. **⚠ WARNING:** Cover the end of the pin bore with a hand or shop rag when removing the retainer ring, since it has a tendency to spring out. Wear eye protection.

NOTE: Piston and piston pins are a matched set and should not be interchanged.

Measure the piston pin bore diameter in two directions on each side. Verify the diameter is within specification.

- If out of specification, install new components as necessary. Refer to the appropriate section in Group 303 for the procedure.



BUY IT NOW!

Click Here To Order

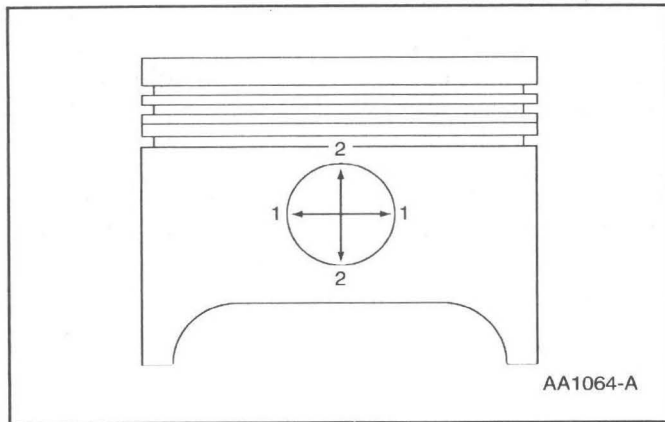
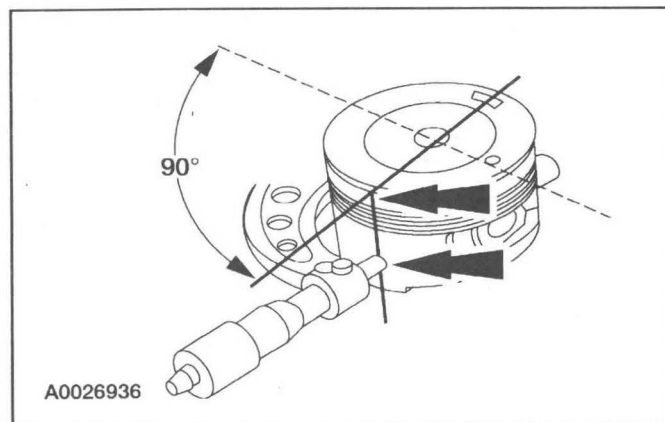

GENERAL PROCEDURES (Continued)**Piston —Diameter**

1. Measure the piston diameter 90 degrees from the piston pin at the points indicated. For additional information, refer to Specifications in the appropriate section in Group 303.
 - If out of specification, install new components as necessary. Refer to the appropriate section in Group 303 for the procedure.

Piston —to Cylinder Bore Clearance

1. Subtract the piston diameter from the cylinder bore diameter to find the piston-to-cylinder bore clearance.

**BUY IT NOW!****Click Here To Order**

GENERAL PROCEDURES (Continued)**Piston — Selection**

NOTE: The cylinder bore must be within the specifications for taper and out-of-round before fitting a piston.

1. Select a piston size based on the cylinder bore.

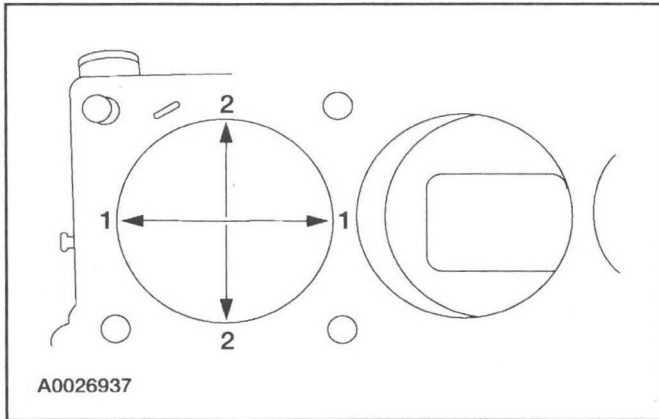

2. **NOTE:** For precision fit, new pistons are divided into three categories within each size range based on their relative position within the range. A paint spot on the new pistons indicates the position within the size range.

Choose the piston with the correct paint color.

- Refer to the appropriate section in Group 303 for the procedure.

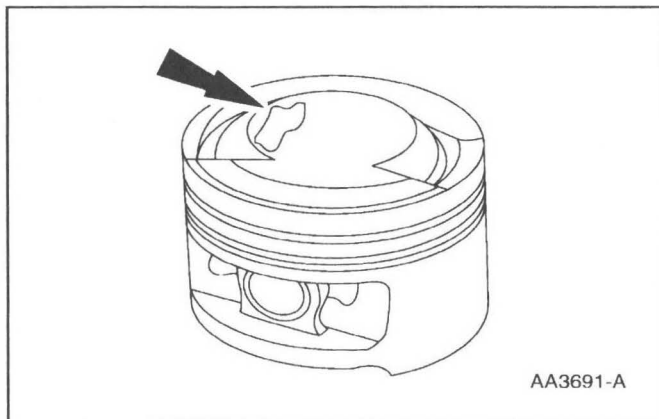
**Piston — Ring End Gap**

CAUTION: Use care when fitting piston rings to avoid possible damage to the piston ring or the cylinder bore.

CAUTION: Piston rings should not be transferred from one piston to another.

NOTE: Cylinder bore must be within specification for taper and out-of-round.

100% SATISFACTION GUARANTEED

BUY IT NOW!

Click Here To Order

PayPal | American Express | Discover | MasterCard | VISA

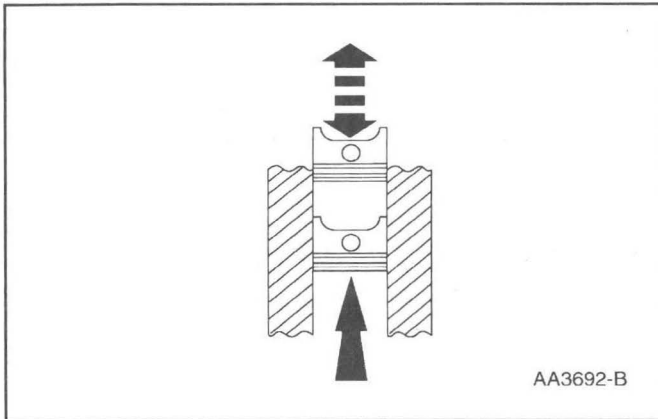
GENERAL PROCEDURES (Continued)

1. Use a piston without rings to push a piston ring in a cylinder to the bottom of ring travel.

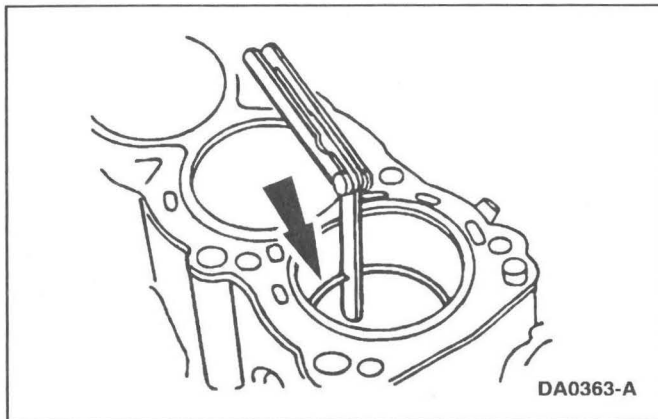

2. Use a feeler gauge to measure the top piston ring end gap and the second piston ring end gap.
 - For additional information, refer to Specifications in the appropriate section in Group 303.

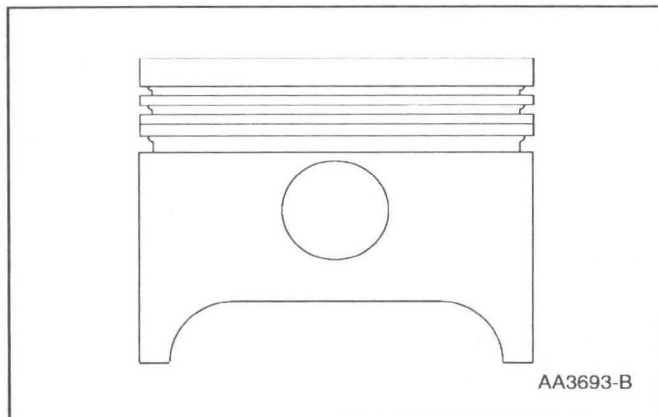
Piston — Ring-to-Groove Clearance

1. Inspect the piston for ring land damage or accelerated wear.



2. Measure the piston ring-to-groove clearance.
 - For additional information, refer to Specifications in the appropriate section in Group 303.
 - If out of specification, install new components as necessary. Refer to the appropriate section in Group 303 for the procedure.

**BUY IT NOW!****Click Here To Order**

GENERAL PROCEDURES (Continued)

Piston — Pin Diameter

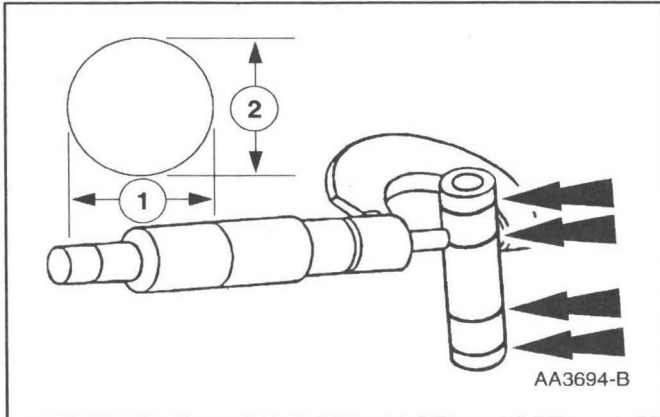

1. Measure the piston pin diameter in two directions at the points shown. Verify the diameter is within specification.
 - For additional information, refer to Specifications in the appropriate section in Group 303.
 - If out of specification, install new components as necessary. Refer to the appropriate section in Group 303 for the procedure.

Connecting Rod — Cleaning

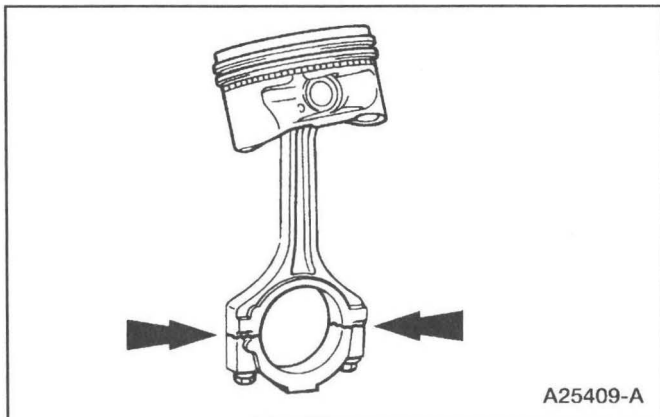

⚠ CAUTION: Do not use a caustic cleaning solution or damage to connecting rods can occur.

1. **NOTE:** The connecting rod large end is a matched set. The connecting rod cap must be installed on the original connecting rod in the original position. Do not reverse the cap. Parts are not interchangeable.

Mark and separate the parts and clean with solvent. Clean the oil passages.

Connecting Rod — Large End Bore

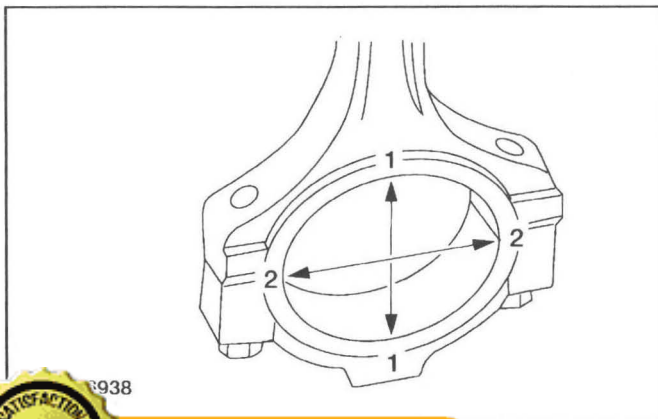

1. Tighten the bolts to specification, then measure the bore in two directions. The difference is the connecting rod bore out-of-round. Verify the out-of-round is within specification.
 - For additional information, refer to Specifications in the appropriate section in Group 303.
 - If out of specification, install new components as necessary. Refer to the appropriate section in Group 303 for the procedure.

938

100% SATISFACTORY GUARANTEED

BUY IT NOW!

Click Here To Order

PayPal | American Express | Discover | MasterCard | VISA

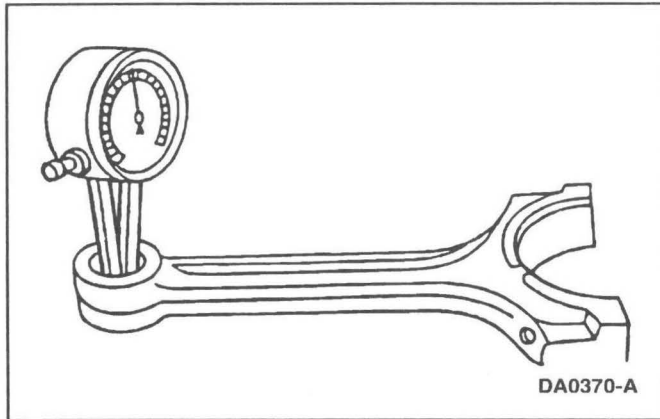
GENERAL PROCEDURES (Continued)**Connecting Rod —Bushing Diameter**

1. Measure the inner diameter of the connecting rod bushing, if equipped. Verify the diameter is within specification.
 - For additional information, refer to Specifications in the appropriate section in Group 303.
 - If out of specification, install new components as necessary. Refer to the appropriate section in Group 303 for the procedure.

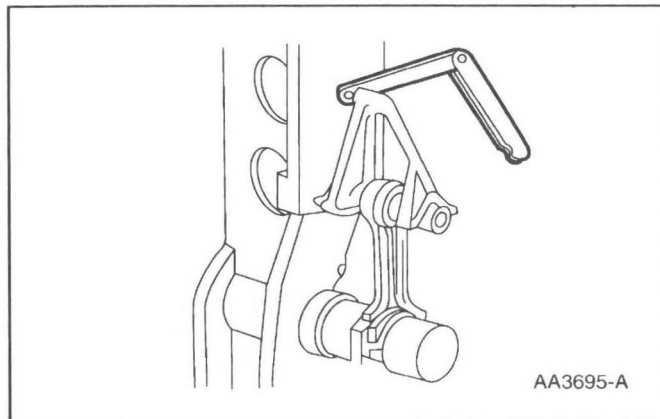
Connecting Rod —Bend

1. Measure the connecting rod bend on a suitable alignment fixture. Follow the instructions of the fixture manufacturer. Verify the bend measurement is within specification.
 - For additional information, refer to Specifications in the appropriate section in Group 303.
 - If out of specification, install new components as necessary. Refer to the appropriate section in Group 303 for the procedure.

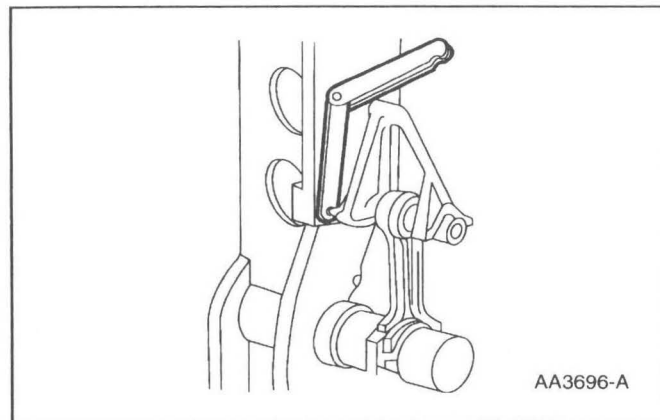
Connecting Rod —Twist

1. Measure the connecting rod twist on a suitable alignment fixture. Follow the instructions of the fixture manufacturer. Verify the measurement is within specification.
 - For additional information, refer to Specifications in the appropriate section in Group 303.
 - If out of specification, install new components as necessary. Refer to the appropriate section in Group 303 for the procedure.

100% SATISFACTION GUARANTEED

BUY IT NOW!

Click Here To Order

GENERAL PROCEDURES (Continued)

Connecting Rod —Piston Pin Side Clearance

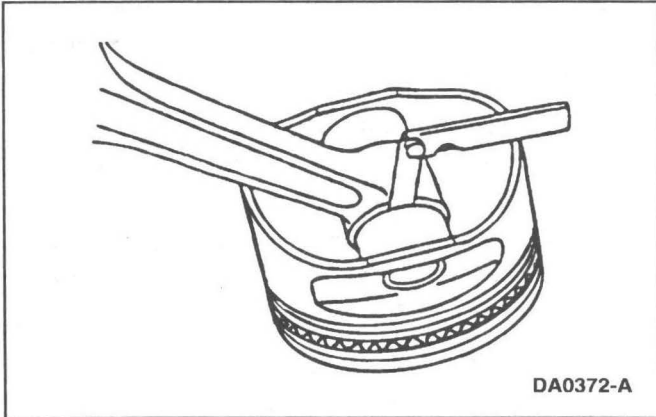

1. Measure the clearance between the connecting rod and the piston. Verify the measurement is within specification.
 - For additional information, refer to Specifications in the appropriate section in Group 303.
 - If out of specification, install new components as necessary. Refer to the appropriate section in Group 303 for the procedure.

Connecting Rod —Bearing Journal Clearance

Special Tool(s)

	Plastigage 303-D031 (D81L-6002-B) or equivalent
--	---

NOTE: The crankshaft connecting rod journals must be within specifications to check the connecting rod bearing journal clearance.

1. Remove the connecting rod bearing cap.
2. Position a piece of Plastigage across the bearing surface.

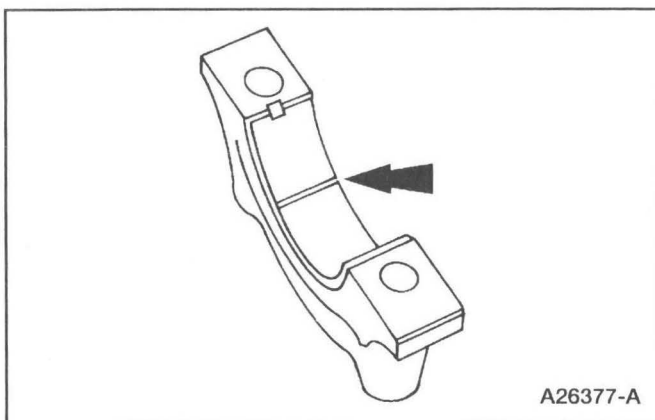

3. **NOTE:** Do not turn the crankshaft during this step.

Install and tighten to specifications, then remove the connecting rod bearing cap.

100% SATISFACTION GUARANTEED

BUY IT NOW!

Click Here To Order

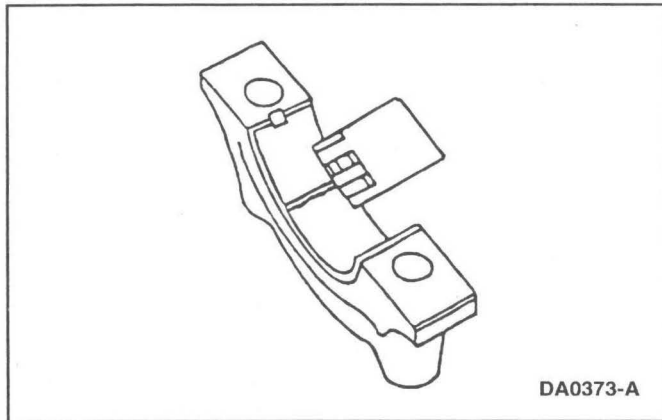
GENERAL PROCEDURES (Continued)

4. Measure the Plastigage to get the connecting rod bearing journal clearance. The Plastigage should be smooth and flat. A changing width indicates a tapered or damaged connecting rod or connecting rod bearing.
 - For additional information, refer to Specifications in the appropriate section in Group 303.
 - If out of specification, install new components as necessary. Refer to the appropriate section in Group 303 for the procedure.

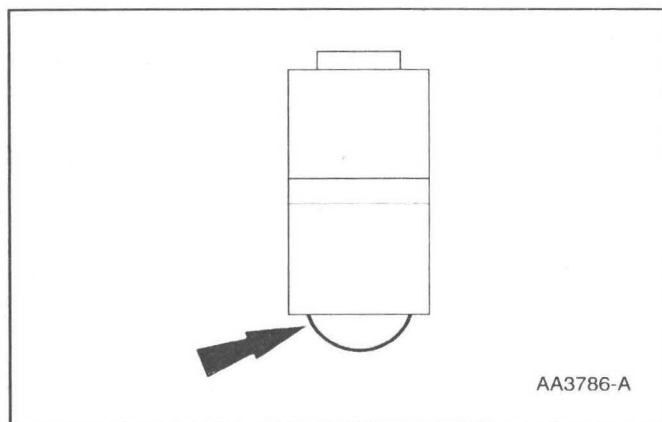
Roller Follower — Inspection**Push rod engines**

1. Inspect the roller for flat spots or scoring. If any damage is found, inspect the camshaft lobes and valve tappet for damage.

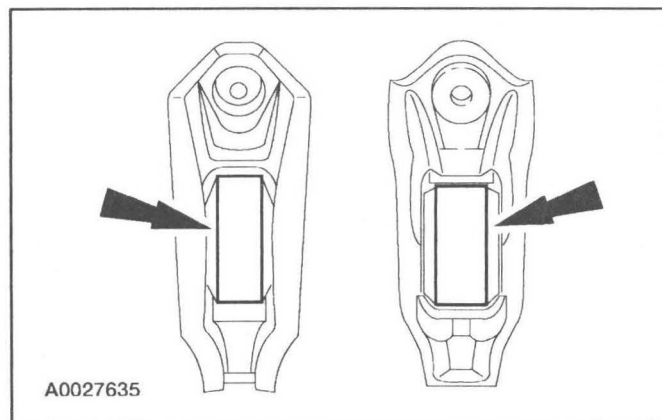
**OHC engines**

100% SATISFACTION GUARANTEED

BUY IT NOW!

Click Here To Order

PayPal American Express Discover MasterCard VISA

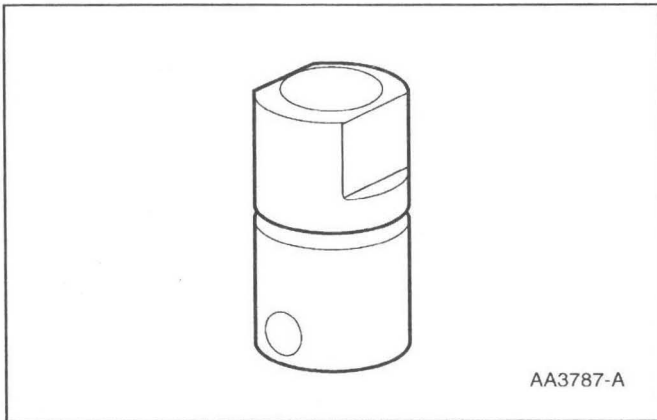
GENERAL PROCEDURES (Continued)**Valve Tappet—Inspection****Push rod engines**

1. Inspect the hydraulic valve tappet and roller for damage. If any damage is found, inspect the camshaft lobes and valves for damage.

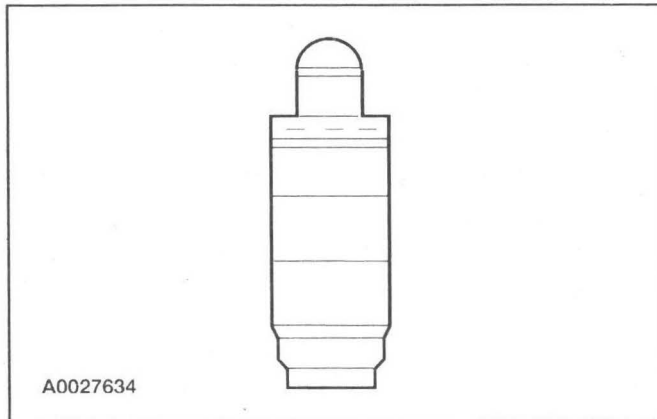
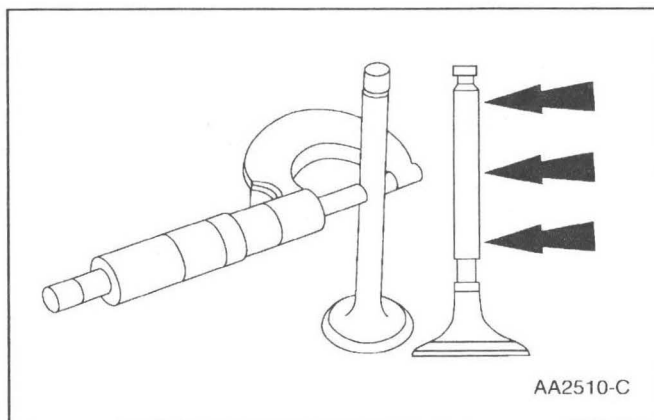
**OHC engines****Valve—Stem Diameter**

1. Measure the diameter of each intake and exhaust valve stem at the points shown. Verify the diameter is within specification.
 - For additional information, refer to Specifications in the appropriate section in Group 303.
 - If out of specification, install new components as necessary. Refer to the appropriate section in Group 303 for the procedure.

**BUY IT NOW!****Click Here To Order**

GENERAL PROCEDURES (Continued)

Valve — Stem to Valve Guide Clearance

Special Tool(s)

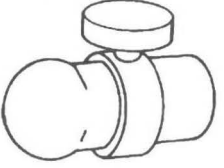
 <p>ST1214-A</p>	<p>Dial Indicator with Bracketry 100-002 (TOOL-4201-C) or equivalent</p>
 <p>ST1251-A</p>	<p>Valve Stem Checking Tool 303-004 (TOOL-6505-E) or equivalent</p>

NOTE: Valve stem diameter must be within specifications before checking valve stem to valve guide clearance.

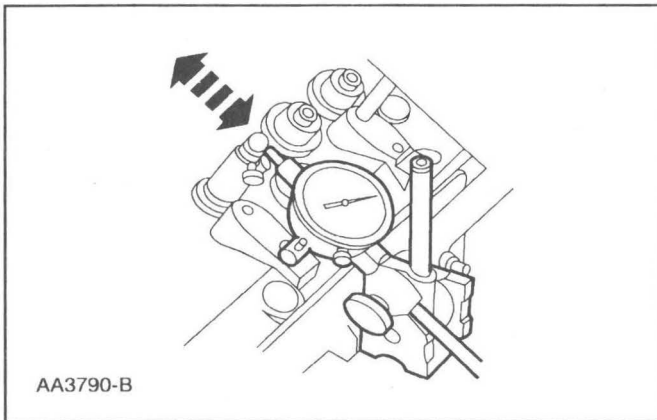

1. **NOTE:** If necessary, use a magnetic base.
Install a Valve Stem Clearance Tool on the valve stem and install a Dial Indicator with Bracketry. Lower the valve until the Valve Stem Clearance Tool contacts the upper surface of the valve guide.
2. Move the Valve Stem Clearance Tool toward the indicator and zero the indicator. Move the Valve Stem Clearance Tool away from the indicator and note the reading. The reading will be **DOUBLE** the valve stem-to-valve guide clearance. Valves with oversize stems will need to be installed if out of specification.



BUY IT NOW!

Click Here To Order



GENERAL PROCEDURES (Continued)

Valve—Inspection

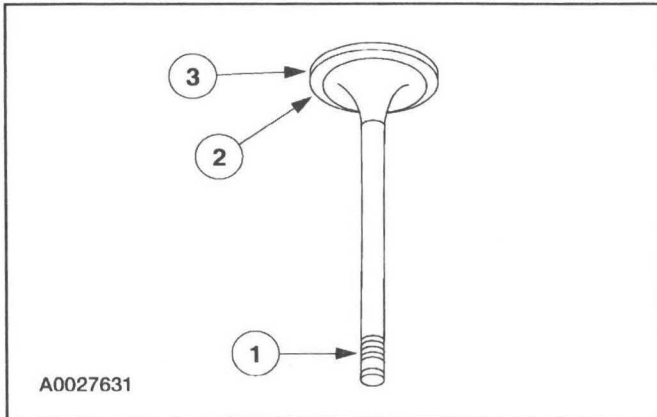

1. Inspect the following valve areas:
 - 1 the end of the stem for grooves or scoring
 - 2 the valve face and the edge for pits, grooves or scores
 - 3 the valve head for signs of burning, erosion, warpage and cracking

Valve—Guide Inner Diameter

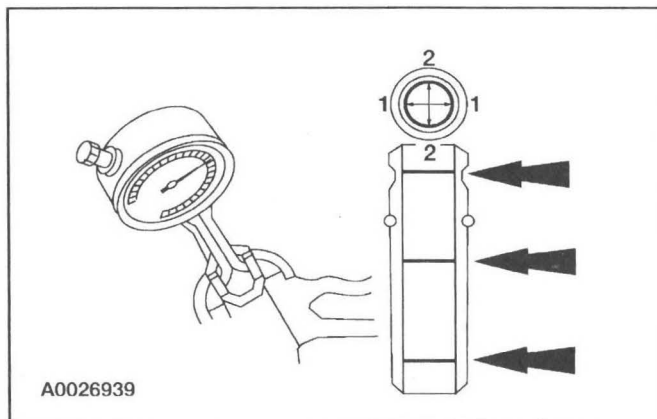

1. Measure the inner diameter of the valve guides in two directions where indicated.
 - For additional information, refer to Specifications in the appropriate section in Group 303.

2. If the valve guide is not within specifications, ream the valve guide and install a valve with an oversize stem or remove the valve guide and install a new valve guide.

Valve—Guide Reaming



1. Use a hand-reaming kit to ream the valve guide.



BUY IT NOW!

Click Here To Order



GENERAL PROCEDURES (Continued)

2. Reface the valve seat.
3. Clean the sharp edges left by reaming.

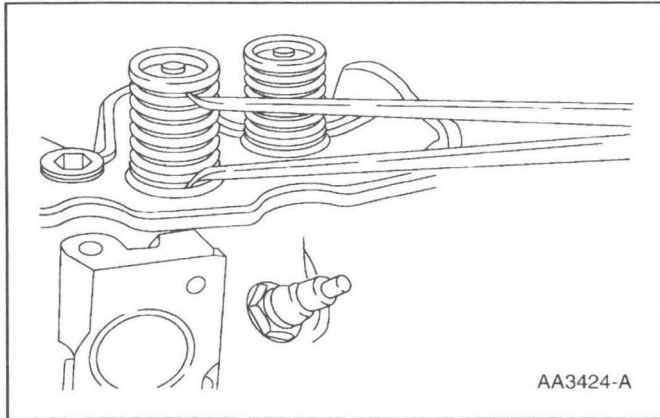
Valve — Spring Installed Length

1. Measure the installed length of each valve spring.
 - For additional information, refer to Specifications in the appropriate section in Group 303.
 - If out of specification, install new components. Refer to the appropriate section in Group 303 for the procedure.

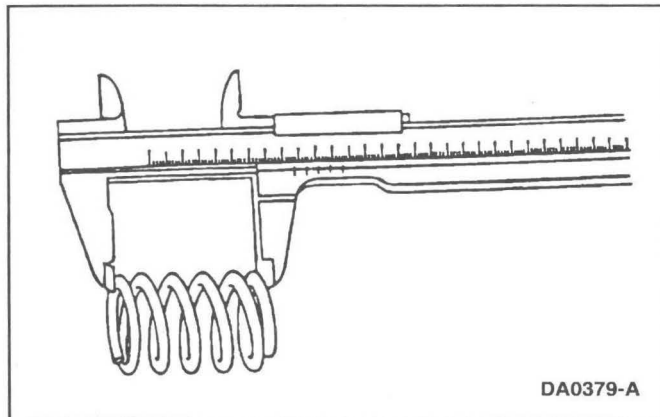
Valve — Spring Free Length

1. Measure the free length of each valve spring.
 - For additional information, refer to Specifications in the appropriate section in Group 303.
 - If out of specification, install new components as necessary. Refer to the appropriate section in Group 303 for the procedure.

Valve — Spring Squareness

1. Measure the out-of-square on each valve spring.
 - Turn the valve spring and observe the space between the top of the valve spring and the square. Install a new valve spring if out of square. Refer to the appropriate section in Group 303 for the procedure.

**BUY IT NOW!****Click Here To Order**

GENERAL PROCEDURES (Continued)

Valve—Spring Strength

Special Tool(s)

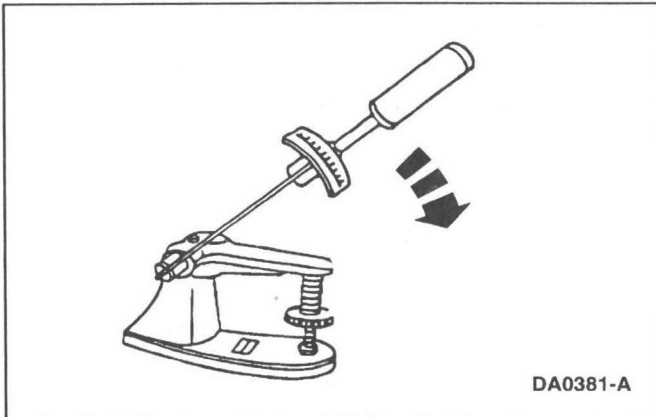
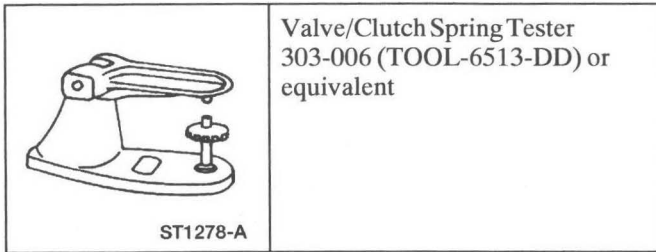

1. Use a Valve/Clutch Spring Tester to check the valve spring for correct strength at the specified valve spring length.
 - For additional information, refer to Specifications in the appropriate section in Group 303.
 - If out of specification, install new components as necessary. Refer to the appropriate section in Group 303 for the procedure.

Valve—Seat Inspection

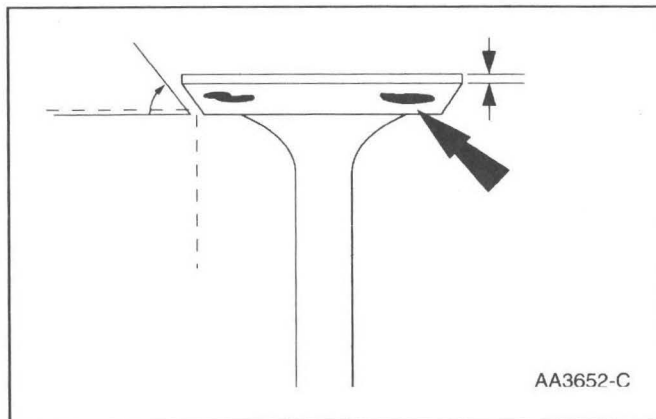

Valve and Seat Refacing Measurements

CAUTION: After grinding valves or valve seats, check valve clearance.

1. Check the valve head and seat.
 - Check valve angles.
 - Check margin width.
 - For additional information, refer to Specifications in the appropriate section in Group 303.
 - Be sure margin width is within specification.
2. Inspect for abnormalities on the valve face and seat.



BUY IT NOW!

Click Here To Order

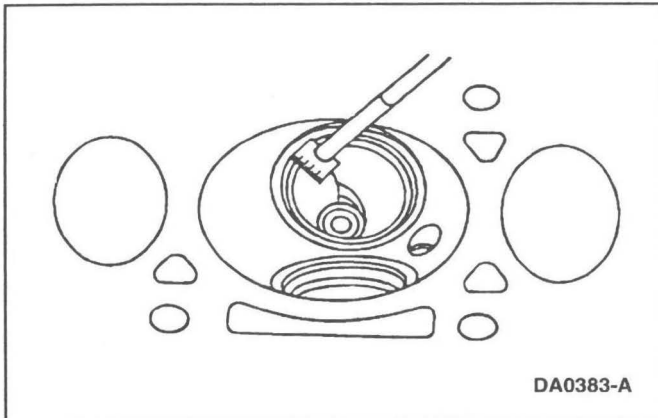

GENERAL PROCEDURES (Continued)**Valve — Seat Width**

1. Measure the valve seat width. If necessary, grind the valve seat to specification.
 - Measure the intake valve seat width.
 - Measure the exhaust valve seat width.
 - Recheck the valve spring installed length after the seats have been ground, and shim the valve springs as necessary to achieve the correct installed spring length.
 - For additional information, refer to Specifications in the appropriate section in Group 303.

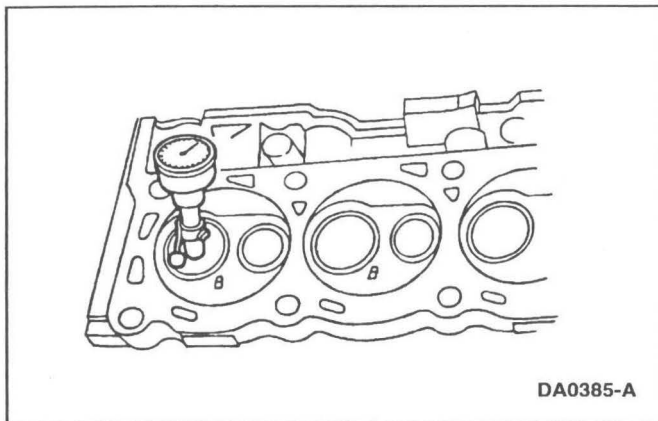
Valve — Seat Runout

1. Use the Valve Seat Runout Gauge to check valve seat runout.

Cylinder Head — Distortion**Special Tool(s)**

<p style="text-align: center;">ST1246-A</p>	<p>Straight Edge 303-D039 (D83L-4201-A) or equivalent</p>
---	---

100% SATISFACTION GUARANTEED

BUY IT NOW!

Click Here To Order

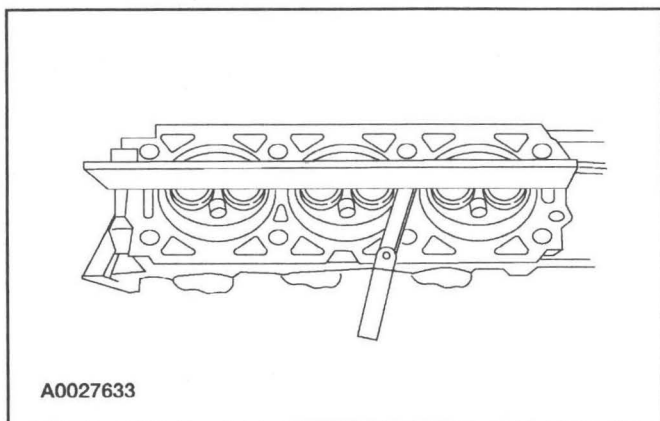
GENERAL PROCEDURES (Continued)

1. Use a straight edge and a feeler gauge to inspect the cylinder head for flatness. If the cylinder head is distorted, install a new cylinder head.

Cylinder Bore —Cleaning

1.  **CAUTION: If these procedures are not followed, rusting of the cylinder bores may occur.**
Clean the cylinder bores with soap or detergent and water.
2. Thoroughly rinse with clean water and wipe dry with a clean, lint-free cloth.
3. Use a clean, lint-free cloth and lubricate the cylinder bores.
 - Use clean engine oil meeting Ford specification.

Cylinder Block —Core Plug Replacement**Special Tool(s)**

 <p>ST1185-A</p>	<p>Impact Slide Hammer 100-001 (T50T-100-A)</p>
---	---

Materials

Item	Specification
Threadlock® 262 E2FZ-19554-A or equivalent	WSK-M2G351-A6

**BUY IT NOW!****Click Here To Order**

GENERAL PROCEDURES (Continued)

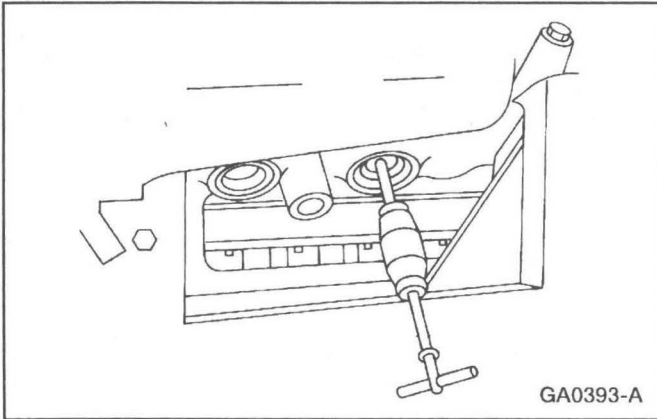

1. Use a slide hammer or tools suitable to remove the cylinder block core plug.

2. Inspect the cylinder block plug bore for any damage that would interfere with the correct sealing of the plug. If the cylinder block plug bore is damaged, bore for the next oversize plug.

3. **NOTE:** Oversize plugs are identified by the OS stamped in the flat located on the cup side of the plug.

Coat the cylinder block core plug and bore lightly with Threadlock® 262 and install the cylinder block core plug.

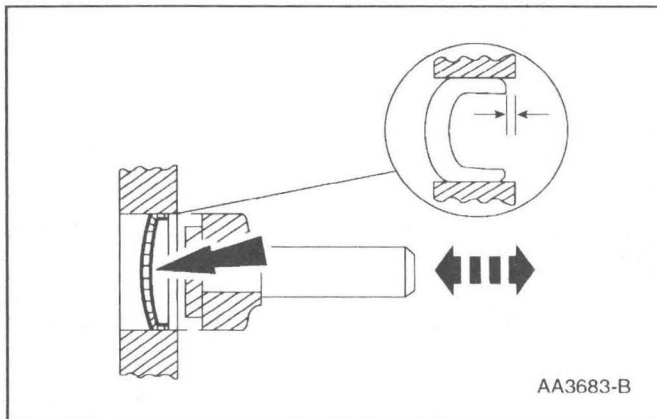
Cup-Type

1. **CAUTION:** Use care during this procedure so as not to disturb or distort the cup sealing surface.
CAUTION: When installed, the flanged edge must be below the chamfered edge of the bore to effectively seal the bore.

Use a tool suitable to seat the cup-type cylinder block core plug.



BUY IT NOW!

Click Here To Order



GENERAL PROCEDURES (Continued)

Expansion-Type

1.  **CAUTION: Do not contact the crown when installing an expansion-type cylinder block core plug. This could expand the plug before seating and result in leakage.**

Use tool suitable to seat the expansion-type cylinder block core plug.

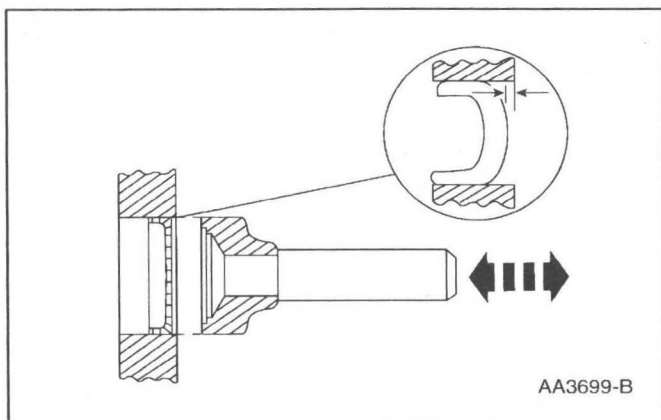

Spark Plug — Inspection

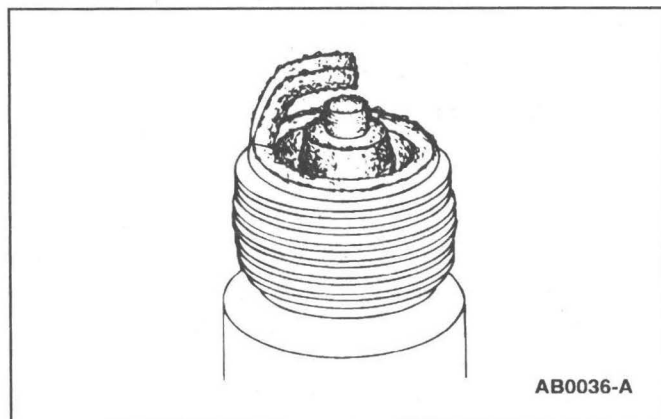
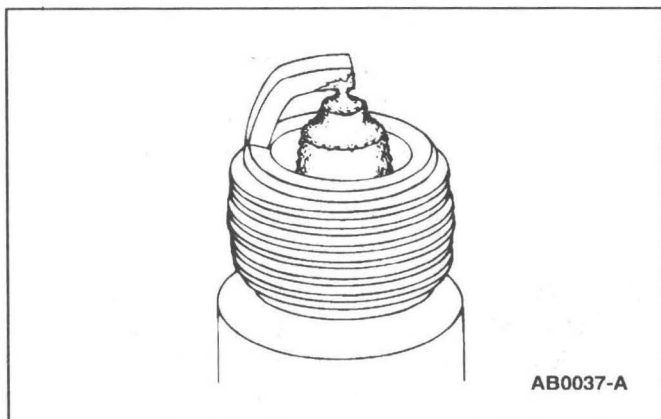

1. Inspect the spark plug for a bridged gap.
 - Check for deposit build-up closing the gap between the electrodes. Deposits are caused by oil or carbon fouling.
 - Clean the spark plug.
2. Check for oil fouling.
 - Check for wet, black deposits on the insulator shell bore electrodes, caused by excessive oil entering the combustion chamber through worn rings and pistons, excessive valve-to-guide clearance or worn or loose bearings.
 - Correct the oil leak concern.
 - Install a new spark plug.

100% SATISFACTION GUARANTEED

BUY IT NOW!

Click Here To Order



GENERAL PROCEDURES (Continued)

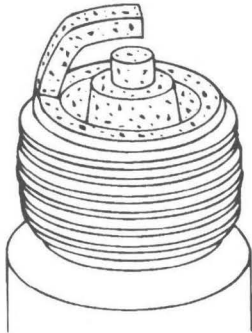

AB0040-A

3. Inspect for carbon fouling. Look for black, dry, fluffy carbon deposits on the insulator tips, exposed shell surfaces and electrodes, caused by a spark plug with an incorrect heat range, dirty air cleaner, too rich a fuel mixture or excessive idling.
 - Clean the spark plug.

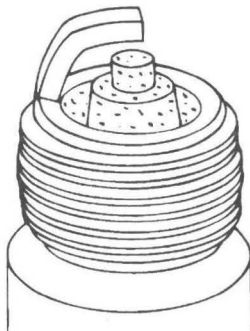

AB0039-A

4. Inspect for normal burning.
 - Check for light tan or gray deposits on the firing tip.

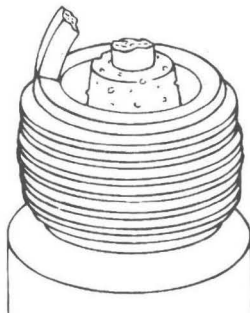

AB0038-A

5. Inspect for pre-ignition, identified by melted electrodes and a possibly damaged insulator. Metallic deposits on the insulator indicate engine damage. This may be caused by incorrect ignition timing, wrong type of fuel or the unauthorized installation of a heli-coil insert in place of the spark plug threads.
 - Install a new spark plug.

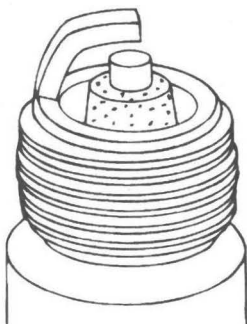

AB0042-A

6. Inspect for overheating, identified by a white or light gray spots and with bluish-burnt appearance of electrodes. This is caused by engine overheating, wrong type of fuel, loose spark plugs, spark plugs with an incorrect heat range, low fuel pump pressure or incorrect ignition timing.
 - Install a new spark plug.



BUY IT NOW!

Click Here To Order

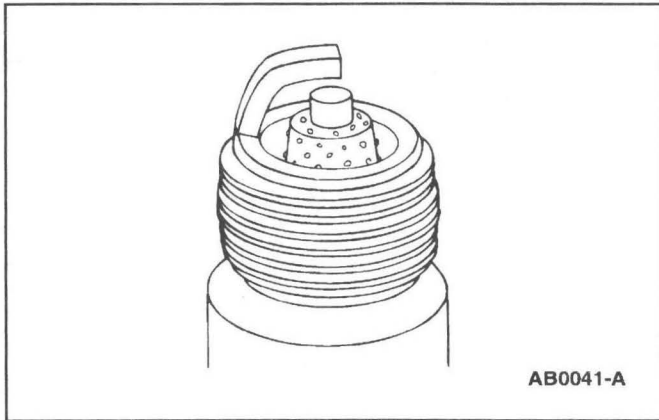

GENERAL PROCEDURES (Continued)

7. Inspect for fused deposits, identified by melted or spotty deposits resembling bubbles or blisters. These are caused by sudden acceleration.
 - Clean the spark plug.

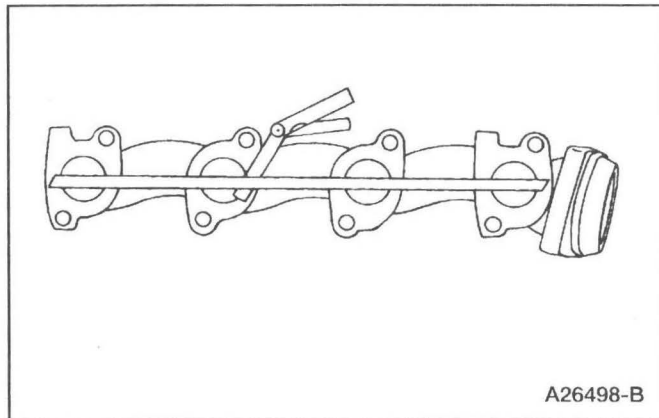
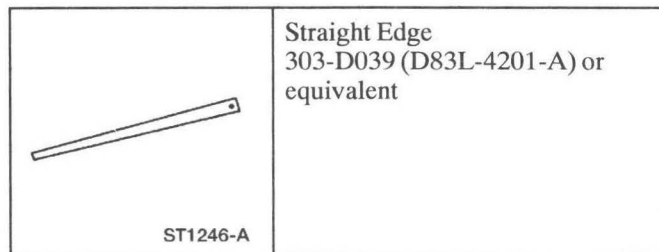
Exhaust Manifold — Inspection**Special Tool(s)**

1. Place a straight edge across the exhaust manifold flanges and check for warping with a feeler gauge.



BUY IT NOW!

Click Here To Order



GENERAL PROCEDURES (Continued)

Bearing — Inspection

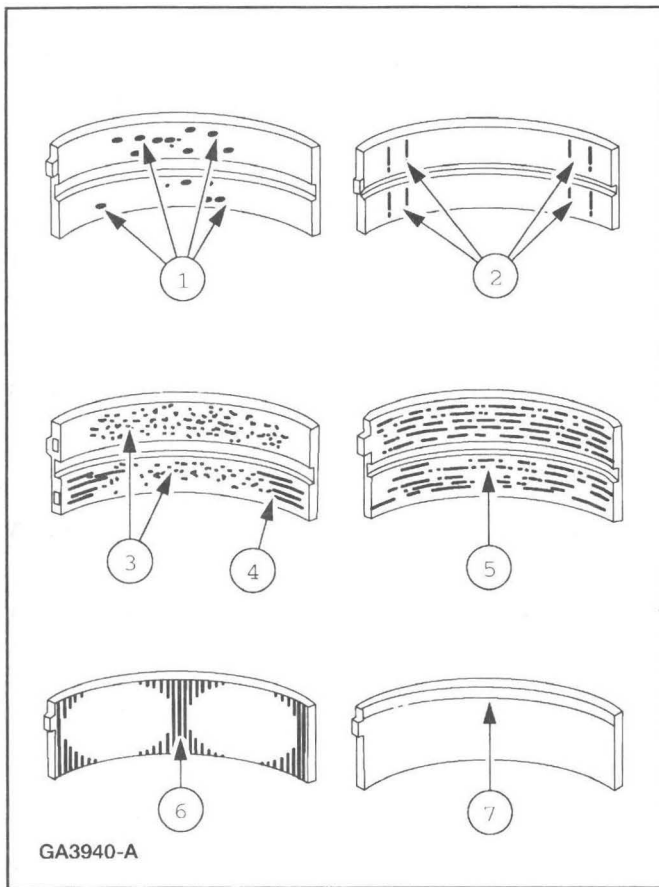

1. Inspect bearings for the following defects. Possible causes are shown:
 - 1 Cratering — fatigue failure.
 - 2 Spot polishing — incorrect seating.
 - 3 Imbedded dirt engine oil.
 - 4 Scratching — dirty engine oil.
 - 5 Base exposed — poor lubrication.
 - 6 Both edges worn — journal damaged.
 - 7 One edge worn — journal tapered or bearing not seated.

SPECIFICATIONS

General Specifications

Item	Specification
Threadlock® 262 E2FZ-19554-B	WSK-M2G351-A6
Lubricants	
Super Premium SAE Motor Oil	Refer to owner literature
Diesel engine oil	Refer to owner literature
Gasoline Engine Oil Dye 164-R3705	ESE-M99C103-B1



BUY IT NOW!

Click Here To Order



SECTION 303-01A Engine — 4.2L

VEHICLE APPLICATION: F150

CONTENTS	PAGE
DESCRIPTION AND OPERATION	
Engine	303-01A-2
DIAGNOSIS AND TESTING	
Engine	303-01A-10
IN-VEHICLE REPAIR	
Camshaft	303-01A-51
Crankshaft Front Oil Seal	303-01A-36
Crankshaft Pulley	303-01A-33
Crankshaft Rear Oil Seal	303-01A-81
Cylinder Head	303-01A-61
Engine Dynamic Balance Shaft	303-01A-52
Engine Front Cover	303-01A-37
Exhaust Manifold LH	303-01A-57
Exhaust Manifold RH	303-01A-59
Flywheel	303-01A-80
Intake Manifold — Spacer Assembly	303-01A-21
Lower Intake Manifold	303-01A-14
Oil Level Indicator and Tube	303-01A-70
Oil Pan — 4x2	303-01A-70
Oil Pan — 4x4	303-01A-73
Oil Pump	303-01A-77
Oil Pump Screen and Pickup Tube	303-01A-79
Timing Chain — Tensioner	303-01A-53
Upper Intake Manifold	303-01A-10
Valve Cover LH	303-01A-27
Valve Cover RH	303-01A-30
Valve Spring	303-01A-45
Valve Tappet	303-01A-48
REMOVAL	
Engine	303-01A-82
DISASSEMBLY	
Engine	303-01A-89
DISASSEMBLY AND ASSEMBLY OF SUBASSEMBLIES	
Cylinder Head	303-01A-103
Piston	303-01A-104
ASSEMBLY	
Engine	303-01A-106
INSTALLATION	
Engine	303-01A-127
Engine	303-01A-134



BUY IT NOW!

Click Here To Order



DESCRIPTION AND OPERATION

Engine

The 4.2L engine has:

- a V-block with six cylinders and splayed crankpins
- a distributorless ignition system
- a multiport, sequential fuel injection (SFI) system
- a variable length induction system (intake manifold runner control)
- overhead valves
- hydraulic valve tappets (6500) for automatic lash adjustment
- connecting rod parting faces that are unique with an interference fit
- an engine dynamic balance shaft (6A311)



BUY IT NOW!
Click Here To Order 



DESCRIPTION AND OPERATION (Continued)

Major Upper Engine Components

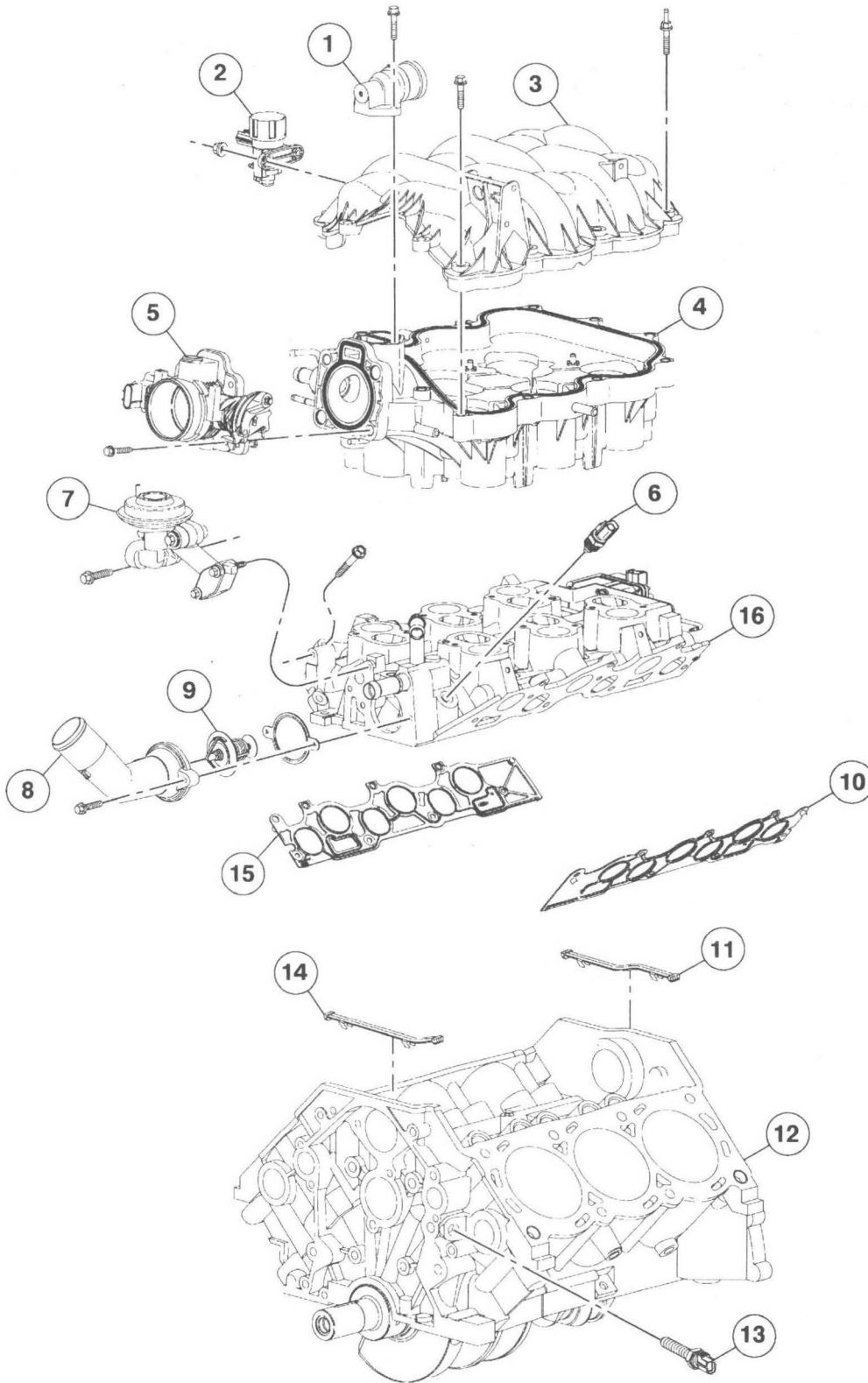

A0032746

BUY IT NOW!

Click Here To Order



DESCRIPTION AND OPERATION (Continued)

Item	Part Number	Description
1	9F715	Idle air control valve
2	95459	EGR vacuum regulator control
3	9424	Upper intake manifold
4	9A589	Spacer assembly intake manifold
5	9E926	Throttle body
6	10884	Water temperature indicator sender unit
7	9D475	EGR valve

(Continued)

Item	Part Number	Description
8	8592	Water hose connection
9	8575	Water thermostat
10	9439	Intake manifold gasket— LH
11	9A424	Intake manifold seal rear
12	6010	Cylinder block
13	9278	Oil pressure sensor
14	9A424	Intake manifold seal front
15	9439	Intake manifold gasket— RH
16	9424	Intake manifold

**BUY IT NOW!****Click Here To Order** 

DESCRIPTION AND OPERATION (Continued)

Cylinder Heads and Valve Train

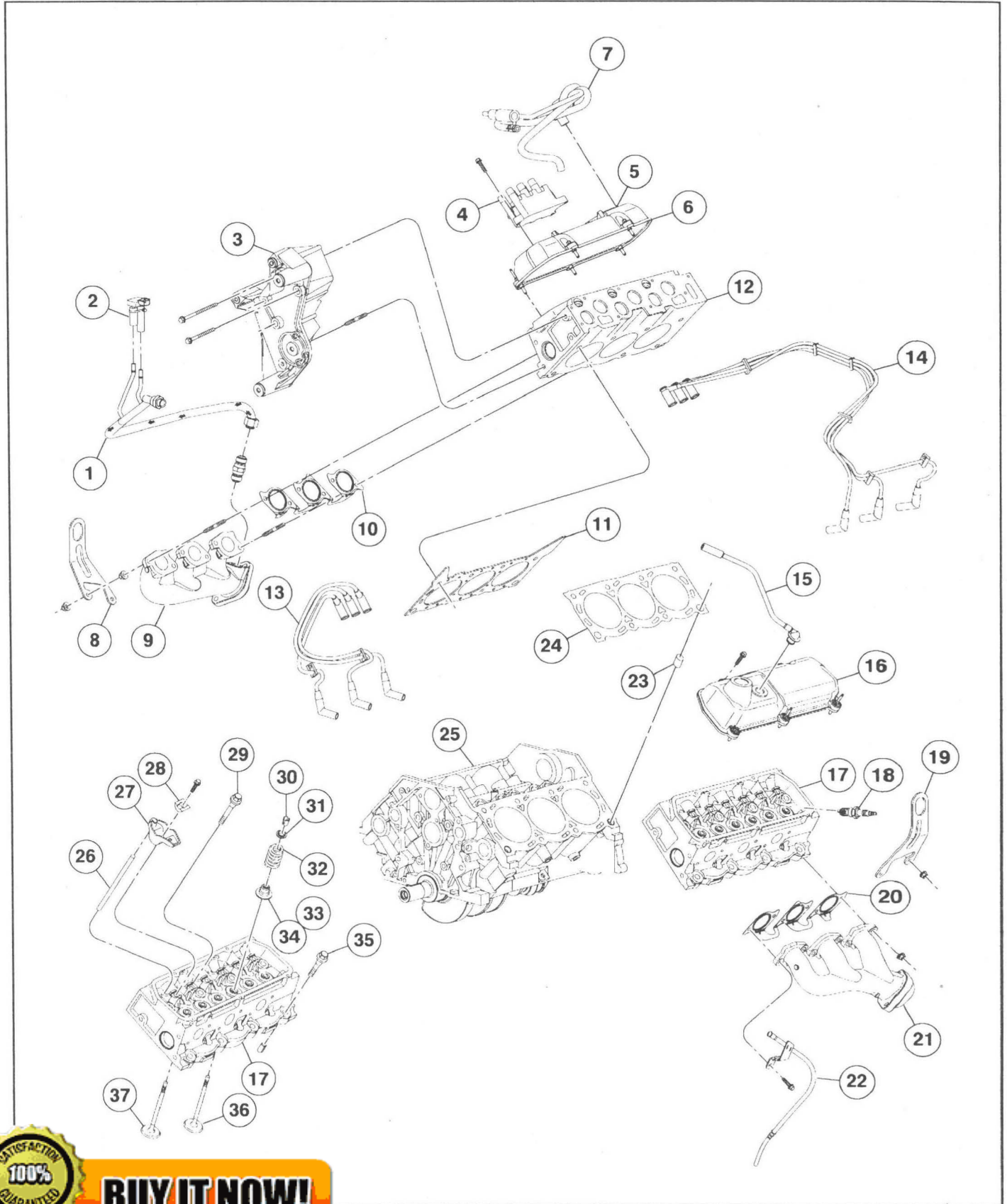

SATISFACTORY 100% GUARANTEED

BUY IT NOW!

Click Here To Order

PayPal | American Express | Discover | MasterCard | VISA

DESCRIPTION AND OPERATION (Continued)

Item	Part Number	Description
1	9D477	EGR valve to exhaust manifold tube
2	9J433	EGR sensor
3	10039	Generator bracket
4	12029	Ignition coil
5	6A666	Positive crankcase ventilation valve
6	6582	Valve cover (RH)
7	6758	Crankcase ventilation tube
8	17A084	Engine lifting eye
9	9430	Exhaust manifold (RH)
10	9448	Exhaust manifold gasket (RH)
11	6051	Head gasket (RH)
12	6049	Cylinder head (RH)
13	12280	Ignition wire and bracket (RH)
14	12280	Ignition wire and bracket (LH)
15	6C324	Crankcase vent connector and hose
16	6582	Valve cover (LH)
17	6049	Cylinder head (LH)
18	12405	Spark plug (6 required)
19	17A084	Engine lifting eye

Item	Part Number	Description
20	9448	Exhaust manifold gasket (LH)
21	9430	Exhaust manifold (LH)
22	6754	Oil level indicator tube
23	6A008	Cylinder heat to block dowel (4 required)
24	6051	Head gasket
25	6010	Cylinder block
26	6565	Push rod (6 required)
27	6564	Rocker arm (6 required)
28	6A528	Rocker arm seat (6 required)
29	N807699	bolt (4 required)
30	6518	Valve spring retainer key (12 required)
31	6514	Valve spring retainer (6 required)
32	6513	Valve spring (6 required)
33	6571	Valve stem seal (6 required)
34	6514	Valve spring retainer (6 required)
35	N807324	Bolt (4 required)
36	6507	Intake valve (6 required)
37	6505	Exhaust valve (6 required)

(Continued)



BUY IT NOW!
Click Here To Order





DESCRIPTION AND OPERATION (Continued)

Cylinder Block and Lower End Components

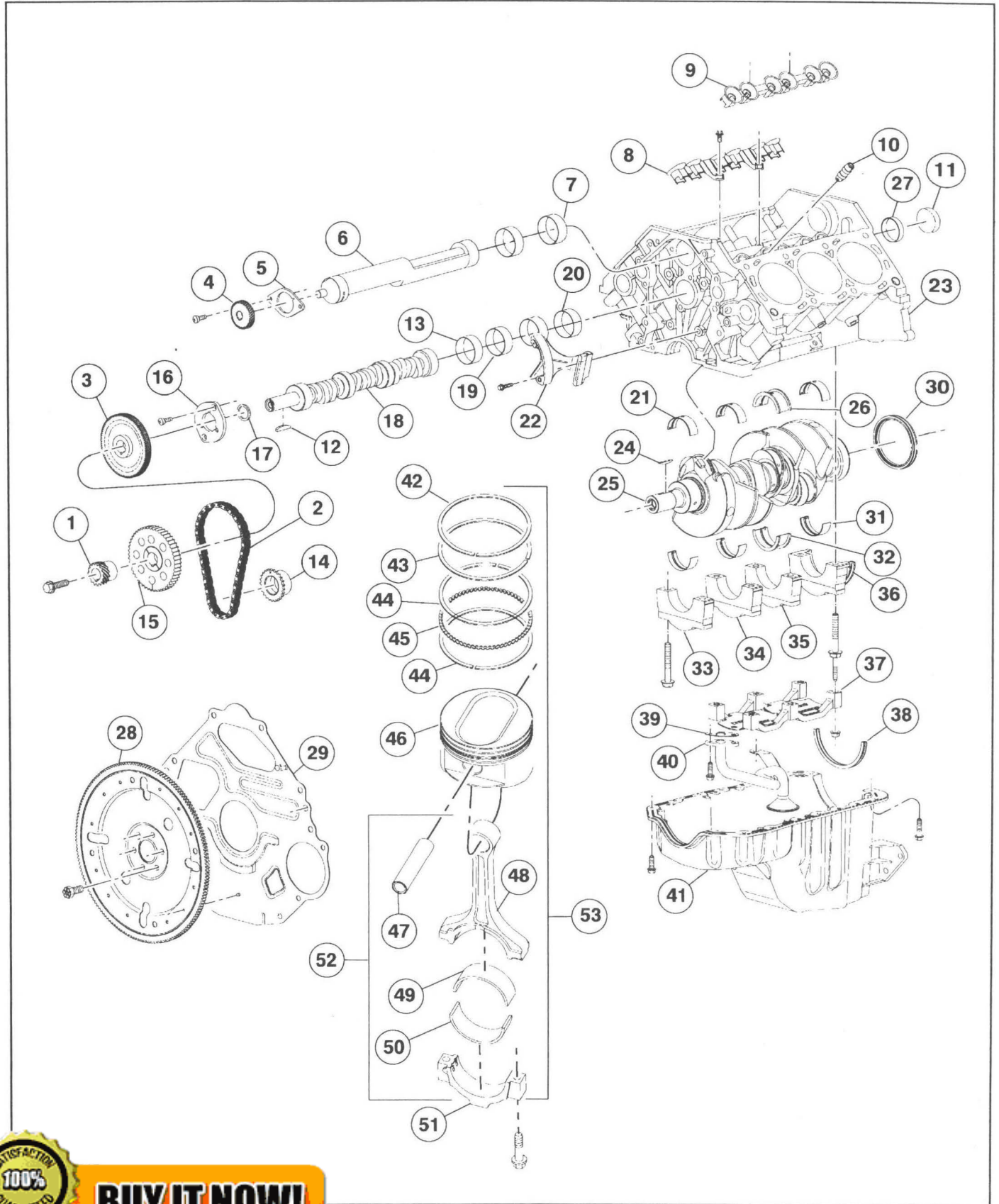

BUY IT NOW!

[Click Here To Order](#)



DESCRIPTION AND OPERATION (Continued)

Item	Part Number	Description
1	6255	Distributor drive gear
2	6268	Timing chain
3	6A303	Engine balance shaft drive gear
4	6A304	Engine balance shaft driven gear
5	6C341	Balance shaft thrust plate
6	6A311	Engine dynamic balance shaft
7	6A333	Balance shaft front and rear bearing (2 required)
8	6K564	Tappet guide plate and retainer (RH)
9	6K564	Tappet guide plate and retainer (LH)
10	6500	Valve tappet (12 required)
11	6A335	Balance shaft cover plug
12	N805256	Woodruffkey
13	6261	Camshaft bearing
14	6306	Crankshaft sprocket
15	6256	Camshaft sprocket
16	6269	Camshaft thrust plate
17	6265	Camshaft sprocket spacer
18	6250	Camshaft
19	6262	Camshaft center bearing (2 required)
20	6263	Camshaft rear bearing
21	6333	Crankshaft main bearing (3 required)
22	6284	Timing chain vibration damper
23	6010	Cylinder block
24	388907	Woodruffkey
25	6303	Crankshaft
26	6337	Crankshaft thrust main bearing
27	6266	Camshaft rear bearing cover (2 required)

(Continued)

Item	Part Number	Description
28	6375	Flywheel
29	6A372	Engine rear plate
30	6701	Crankshaft rear oil seal
31	6333	Crankshaft main bearing (3 required)
32	6337	Crankshaft thrust main bearing
33	6329	Main bearing cap
34	6334	Main bearing cap
35	6327	Main bearing cap
36	6325	Rear main bearing cap
37	6A835	Oil pan baffle assembly
38	6723	Oil pan rear seal
39	6626	Oil pump inlet tube gasket
40	6622	Oil pump screen cover and tube
41	6675	Oil pan
42	6150	Piston ring (6 required)
43	6152	Piston ring (6 required)
44	6159	Piston ring (6 required)
45	6161	Piston ring (6 required)
46	6108	Piston
47	6135	Piston pin (6 required)
48	6200	Connecting rod (6 required)
49	6211	Connecting rod bearing (upper) (6 required)
50	6211	Connecting rod bearing (lower) (6 required)
51	6210	Connecting rod cap (6 required)
52	6200	Connecting rod assembly (6 required)
53	6100	Piston and connecting rod assembly (6 required)

100% SATISFACTION GUARANTEED

BUY IT NOW!

Click Here To Order



DESCRIPTION AND OPERATION (Continued)

Engine Front Cover Components

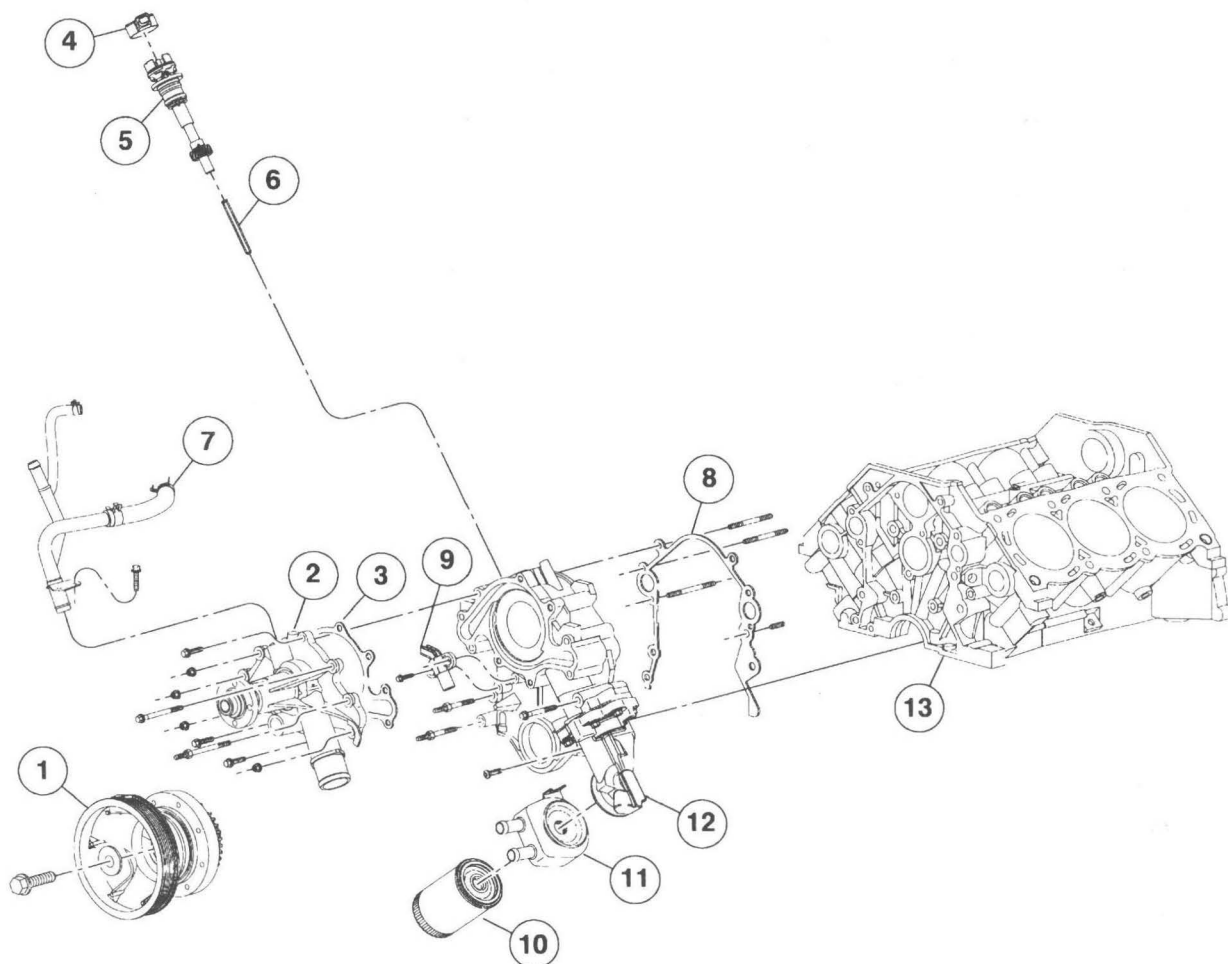

A0032747

Item	Part Number	Description
1	6312	Crankshaft pulley
2	8501	Water pump
3	8507	Water pump housing gasket
4	12A112	Camshaft position sensor
5	12A362	Camshaft synchronizer
	6A618	Oil pump intermediate shaft outlet tube

Item	Part Number	Description
8	6020	Engine front cover gasket
9	6C315	Crankshaft position sensor
10	6714	Oil bypass filter
11	6A642	Oil cooler
12	6019	Engine front cover
13	6010	Cylinder block



BUY IT NOW!

Click Here To Order



DIAGNOSIS AND TESTING

Engine

Refer to Section 303-00 for basic mechanical concerns or refer to the Powertrain Control/Emissions Diagnosis (PC/ED) manual ¹ for driveability concerns.

IN-VEHICLE REPAIR

Upper Intake Manifold

Removal

1. Remove the engine air cleaner outlet tube. For additional information, refer to Section 303-12.
2. Disconnect the idle air control (IAC) valve electrical connector.
3. Remove the idle air control (IAC) valve assembly.

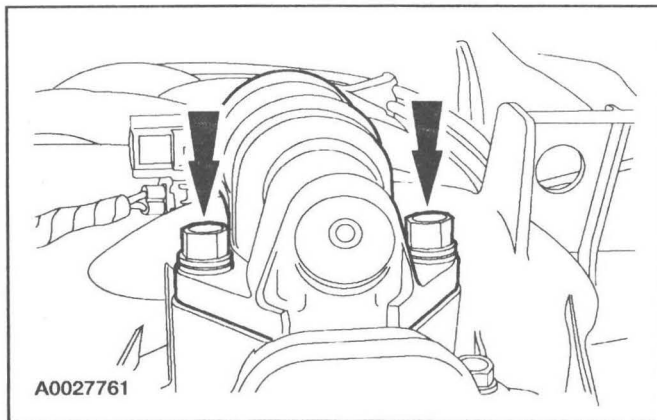
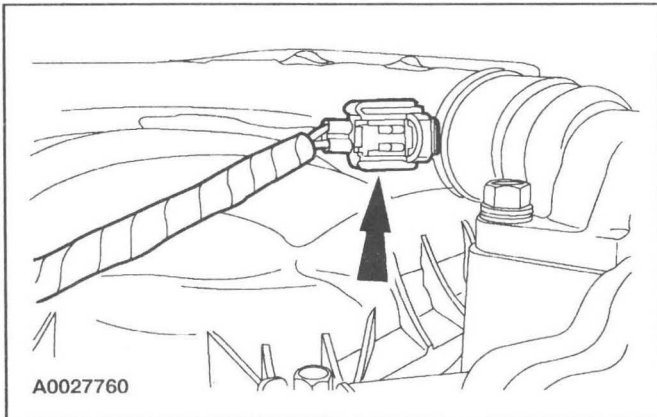

100% SATISFACTION GUARANTEED

BUY IT NOW!

Click Here To Order

Can be purchased as a separate item.

PayPal | American Express | Discover | MasterCard | VISA

IN-VEHICLE REPAIR (Continued)

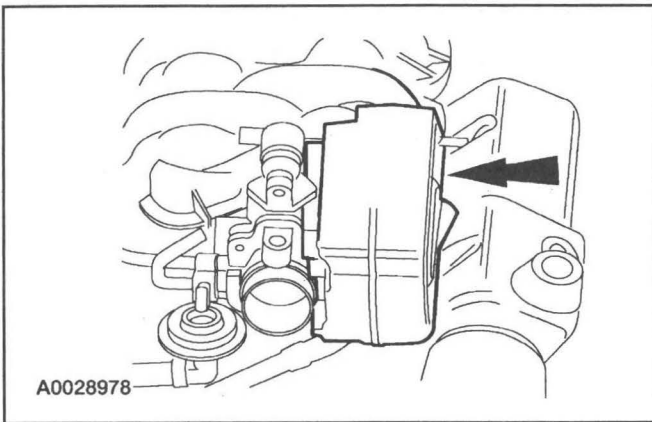

A0028978

4. Remove the pushpin and the accelerator control splash shield.

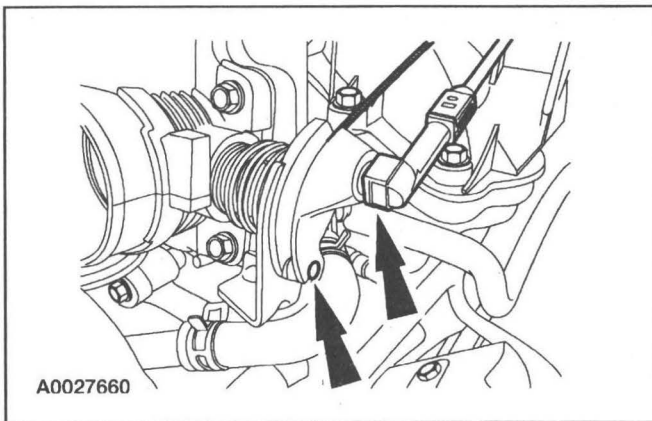

A0027660

5. Disconnect the accelerator cable end and, if equipped, the speed control actuator cable end.

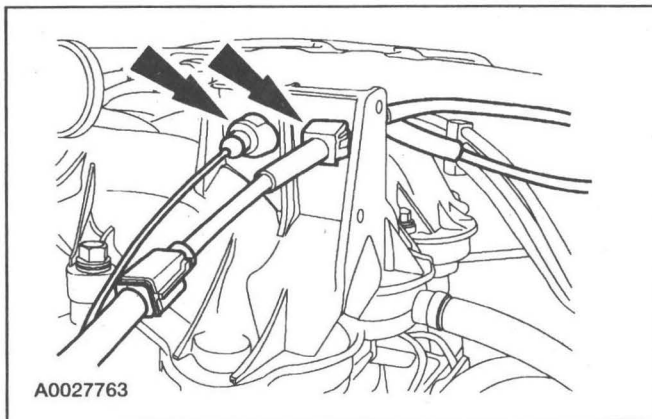

A0027763

6. Detach the accelerator cable (9A758) and, if equipped, the speed control actuator cable (9A825).

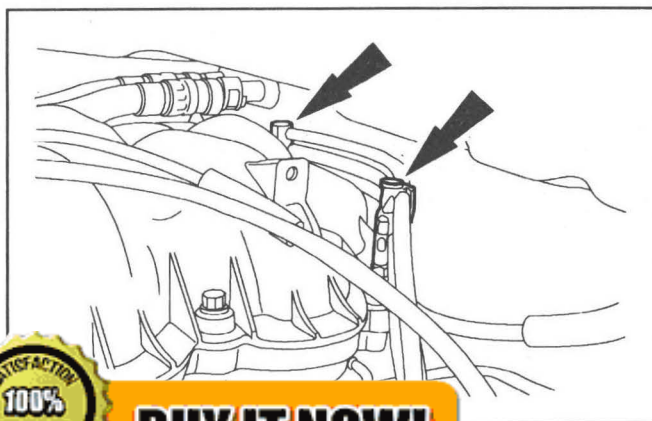

7. Remove the crankcase ventilation hose. Disconnect the spark plug wire holders.

**BUY IT NOW!****Click Here To Order**

IN-VEHICLE REPAIR (Continued)

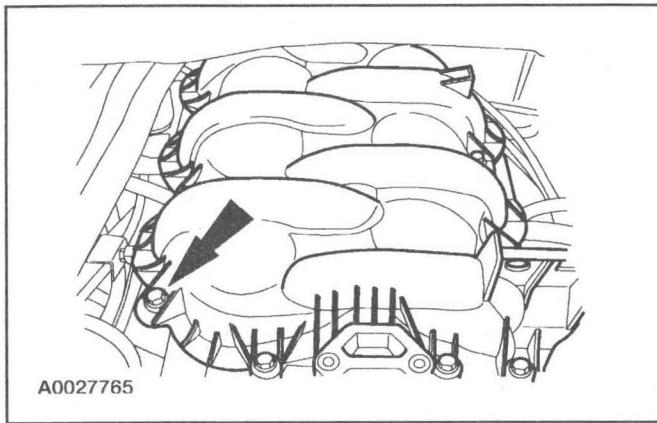

- Remove the twelve bolts and the upper intake manifold.

Installation

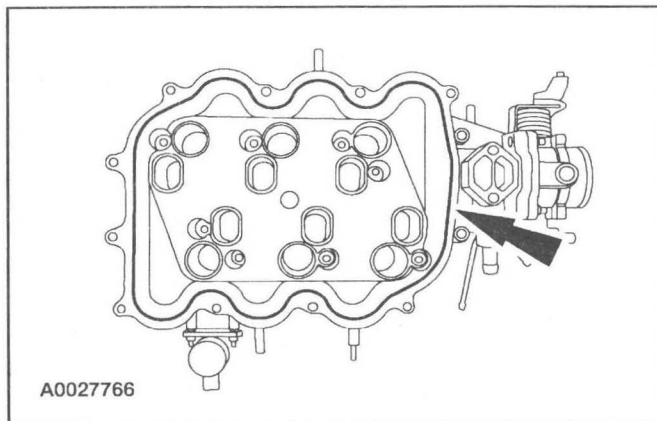

- Inspect the intake manifold upper gasket. Install a new gasket, if necessary.

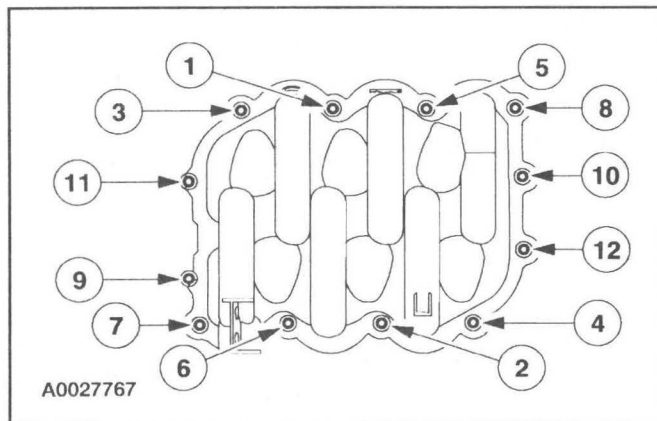

- Position the upper intake manifold and tighten the upper intake manifold bolts in the sequence shown in two stages.
 - Stage 1: Tighten the bolts to 6 Nm (53 lb-in).
 - Stage 2: Tighten the bolts to 10 Nm (89 lb-in).



- Connect the spark plug wire holders.



BUY IT NOW!

Click Here To Order



IN-VEHICLE REPAIR (Continued)

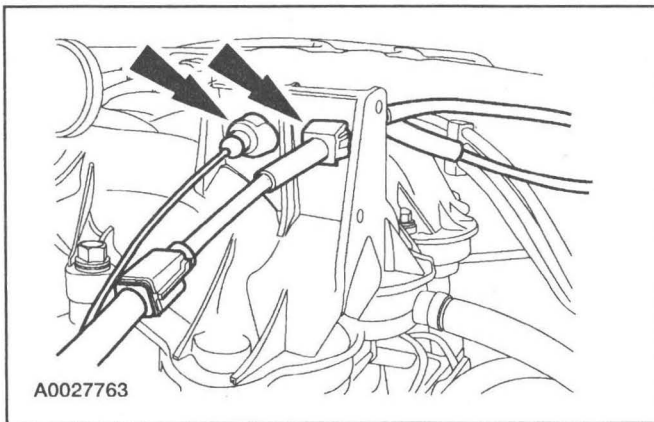

A0027763

4. Install the accelerator cable and, if equipped, the speed control actuator cable.

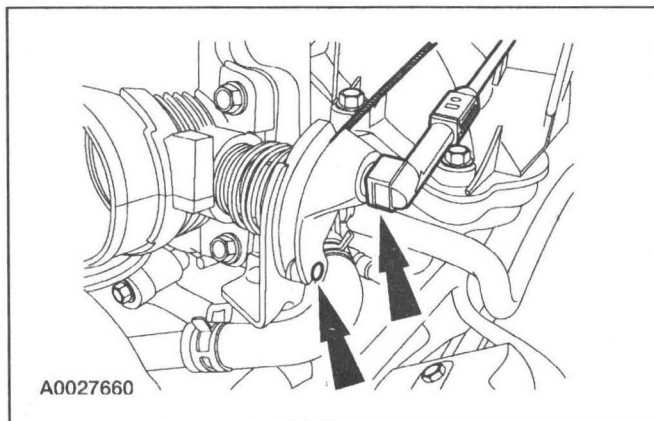

A0027660

5. Attach the accelerator cable end and, if equipped, the speed control actuator cable end.

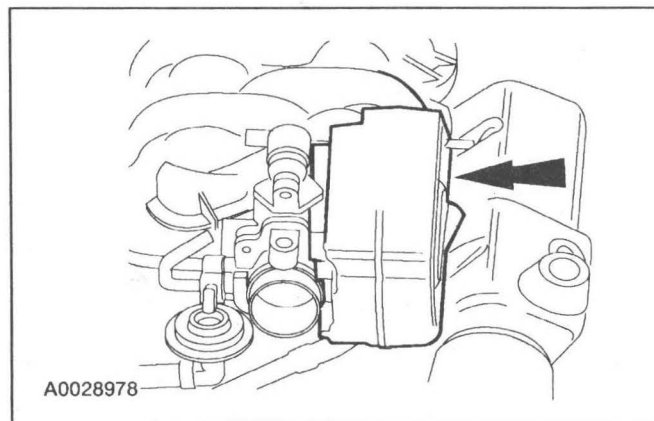

A0028978

6. Position the accelerator control splash shield and install a new pushpin.



7. Install the idle air control (IAC) valve assembly.

**BUY IT NOW!****Click Here To Order**

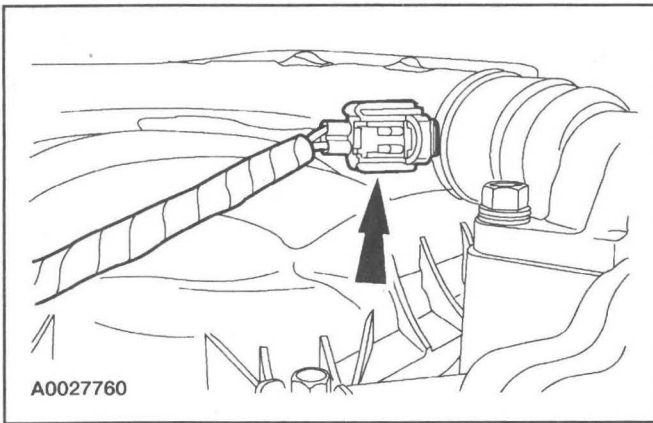
IN-VEHICLE REPAIR (Continued)

8. Connect the idle air control (IAC) valve electrical connector.

9. Install the engine air cleaner outlet tube. For additional information, refer to Section 303-12.

Lower Intake Manifold**Materials**

Item	Specification
Silicone Gasket and Sealant F7AZ-19554-EA or equivalent	WSE-M4G323-A4

Removal

1. Remove the upper intake manifold (9424). For additional information, refer to Upper Intake Manifold in this section.
2. **NOTE:** One shown, all are similar.
Disconnect the fuel injector electrical connectors.

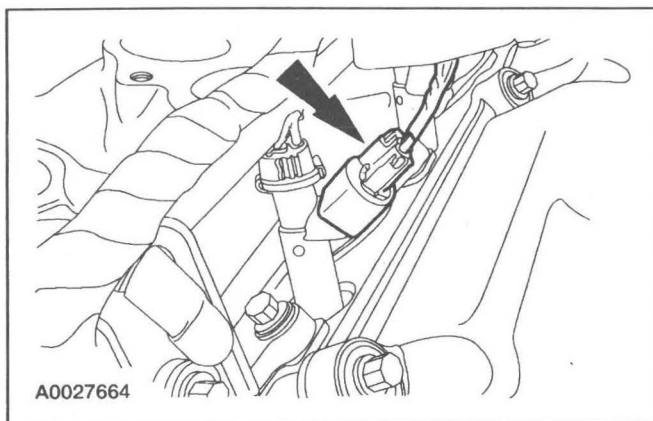

100% SATISFACTION GUARANTEED

BUY IT NOW!

Click Here To Order

PayPal Discover MasterCard VISA

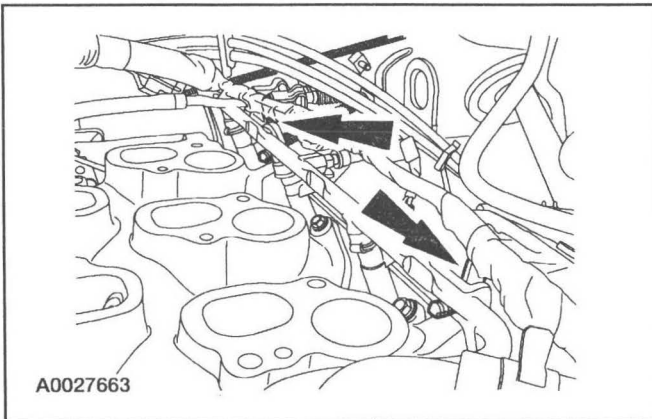
IN-VEHICLE REPAIR (Continued)

3. **NOTE:** Left side shown, right side similar.
Disconnect the fuel injector electrical harness from the fuel injector supply manifold.

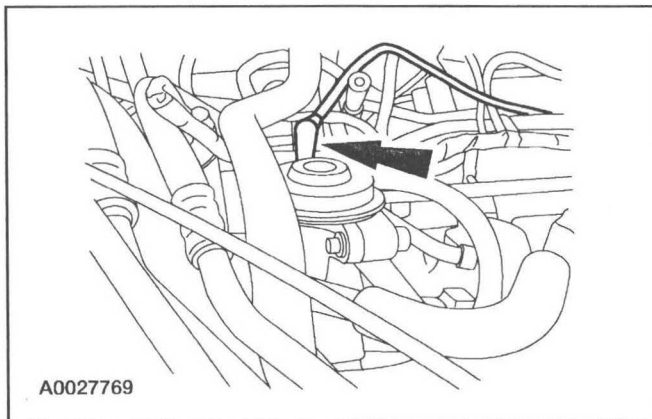

4. Disconnect the exhaust gas recirculation (EGR) valve vacuum hose.

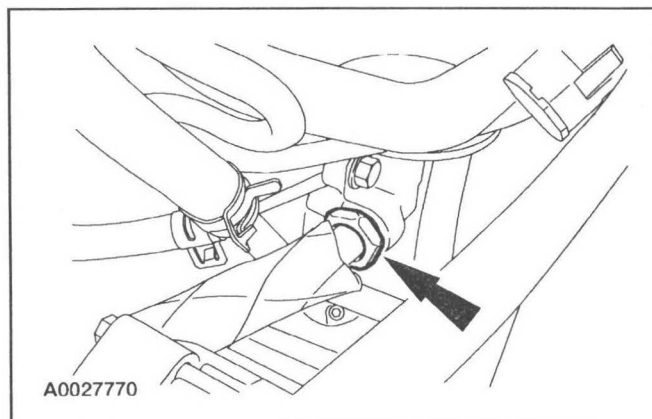

5. Remove the EGR valve to exhaust manifold tube upper fitting.

6. Remove the upper radiator hose from the lower intake manifold.



BUY IT NOW!

Click Here To Order



IN-VEHICLE REPAIR (Continued)

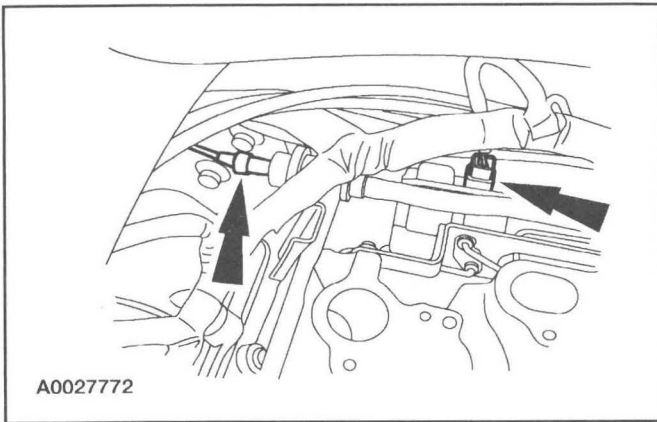

7. Disconnect the intake manifold runner control (IMRC) electrical connector and the fuel pressure regulator vacuum line.

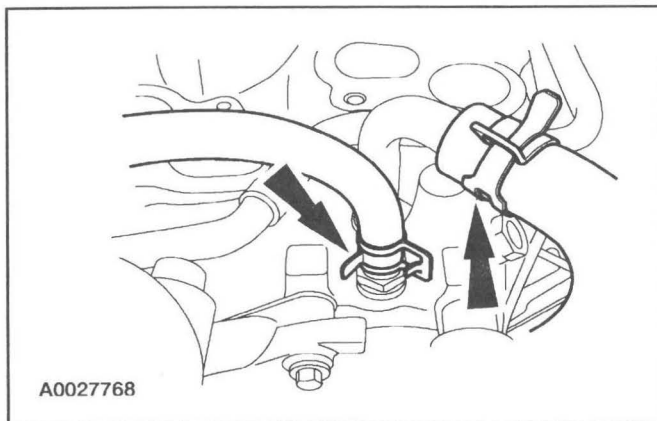

8. Disconnect the fuel lines. For additional information, refer to Section 310-01A.
9. Disconnect the water bypass hose and the heated positive crankcase ventilation (PCV) system heater water hose.

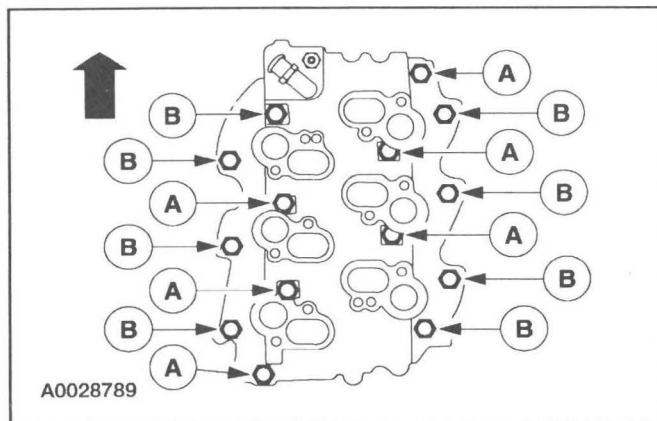

10. **NOTE:** Remove the lower intake manifold including the fuel injection supply manifold, the fuel injectors and the IMRC.

NOTE: If the lower intake manifold will be replaced, the fuel injection supply manifold, fuel injectors and the IMRC will need to be transferred. For additional information, refer to Section 303-04A for the fuel supply manifold and fuel injectors and Section 303-14 for the IMRC.

Remove the (A) long lower intake manifold bolts, the (B) short lower intake manifold bolts and remove the lower intake manifold.



BUY IT NOW!

[Click Here To Order](#)



IN-VEHICLE REPAIR (Continued)

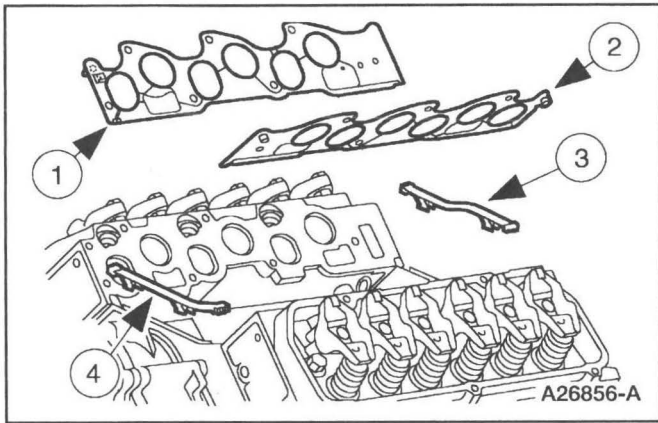

11. Remove and discard the lower intake manifold sealing components.

Item	Part Number	Description
1	9439	Intake manifold gasket — RH
2	9441	Intake manifold gasket — LH
3	9A424	Intake manifold rear end seal (part of 9439)
4	9A425	Intake manifold front end seal (part of 9439)

Installation

1. For additional information, refer to the illustration for intake manifold sealing component locations.

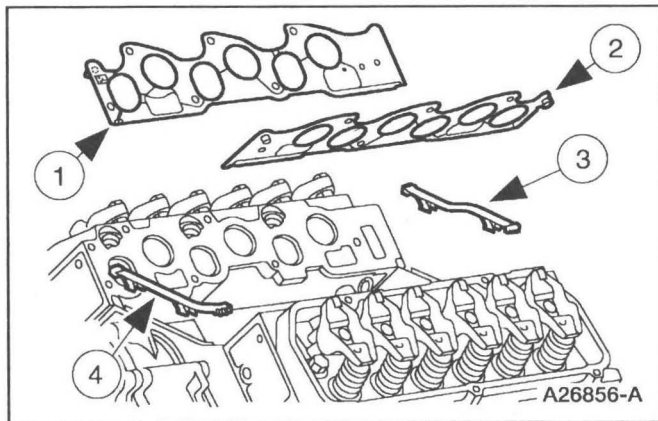

Item	Part Number	Description
1	9439	Intake manifold gasket — RH
2	9441	Intake manifold gasket — LH
3	9A424	Intake manifold rear end seal (part of 9439)
4	9A425	Intake manifold front end seal (part of 9439)

100% SATISFACTION GUARANTEED

BUY IT NOW!

Click Here To Order







IN-VEHICLE REPAIR (Continued)

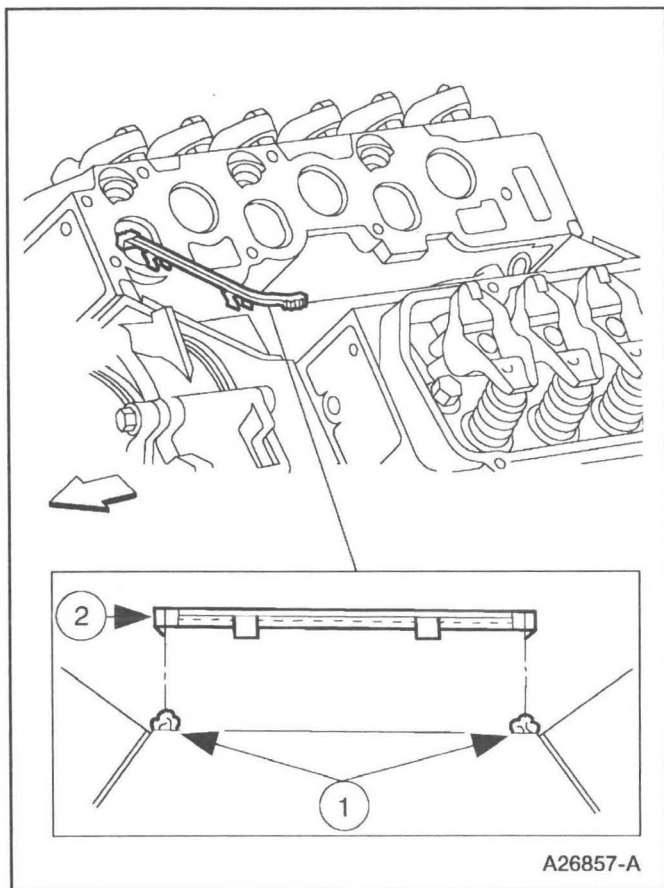

2. Install the lower intake manifold front and rear end seals.
 - 1 Apply a bead of silicone gasket and sealant to the intake manifold front and rear end seal mounting points as indicated.
 - 2 Install the lower intake manifold front and rear end seals.

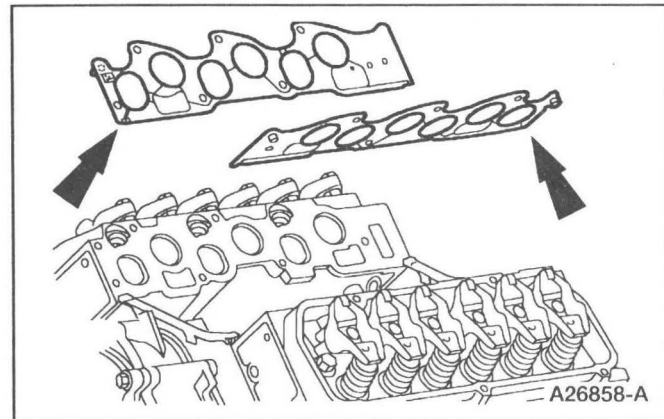

3. Install the intake manifold gaskets.

100% SATISFACTION GUARANTEED

BUY IT NOW!

Click Here To Order

PayPal American Express Discover MasterCard VISA

IN-VEHICLE REPAIR (Continued)

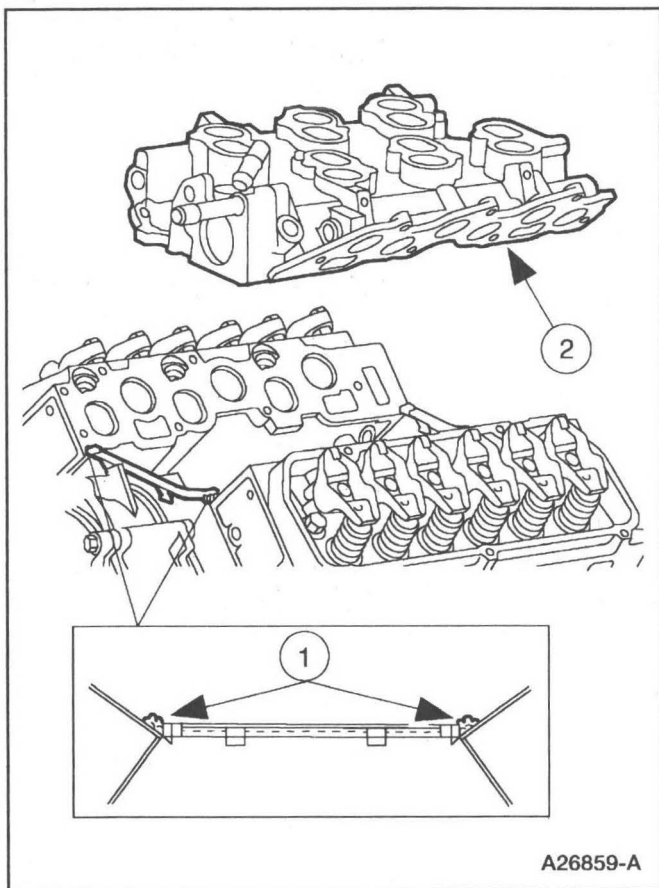

4. **NOTE:** The lower intake manifold must be installed within four minutes of applying sealant. Position the lower intake manifold.

- 1 Apply a bead of silicone gasket and sealant to the lower intake manifold mounting at the points indicated.
- 2 Position the lower intake manifold.

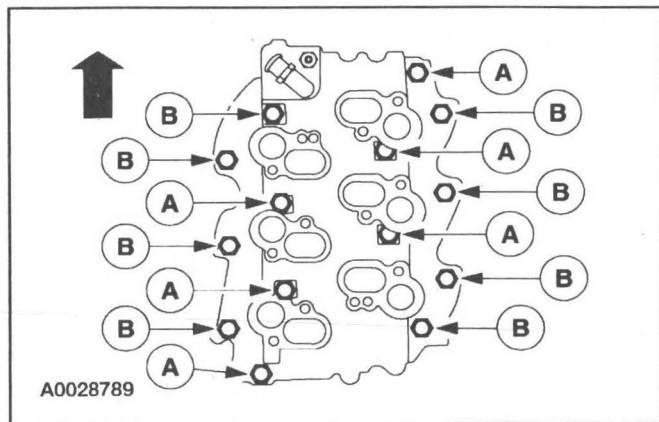

5. **NOTE:** Make sure the bolts are installed in the correct location. Loosely install the (A) long bolts and the (B) short bolts.



6. Tighten the bolts in the sequence shown in two stages.
- Stage 1: Tighten the bolts to 5 Nm (44 lb-in).
 - Stage 2: Tighten the bolts to 12 Nm (9 lb-ft).



BUY IT NOW!

Click Here To Order



IN-VEHICLE REPAIR (Continued)

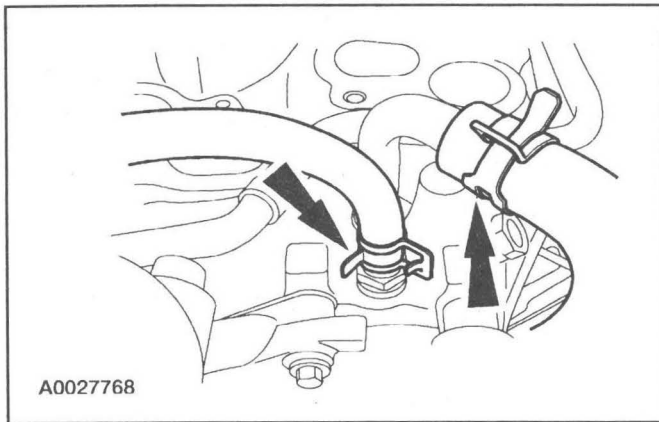

7. Connect the water bypass hose and the heated PCV system heater water hose.

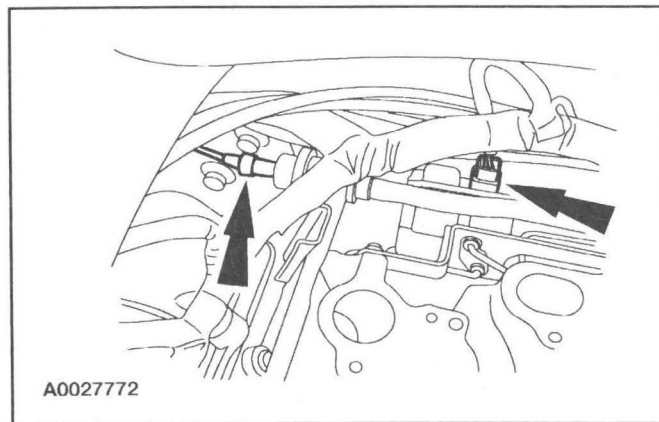

8. Connect the fuel lines. For additional information, refer to Section 310-01A.
9. Connect the fuel pressure regulator vacuum line and the IMRC electrical connector.

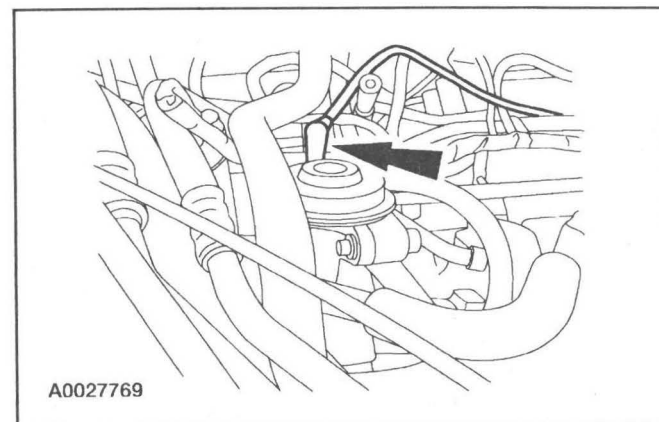

10. Install the upper radiator hose to the lower intake manifold.
11. Connect the EGR valve vacuum hose.



BUY IT NOW!

Click Here To Order

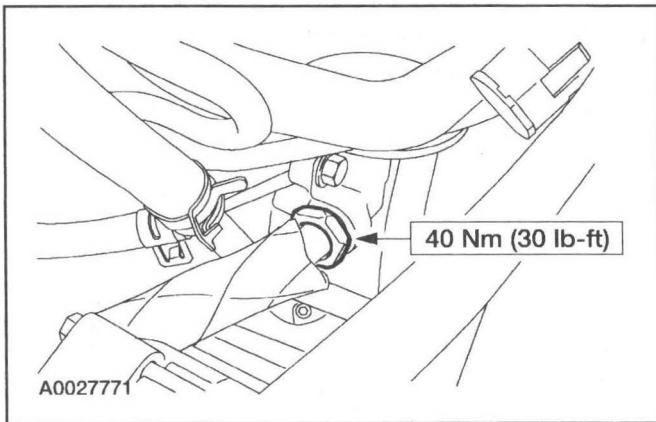

IN-VEHICLE REPAIR (Continued)

12. Install the EGR valve to exhaust manifold tube upper fitting.

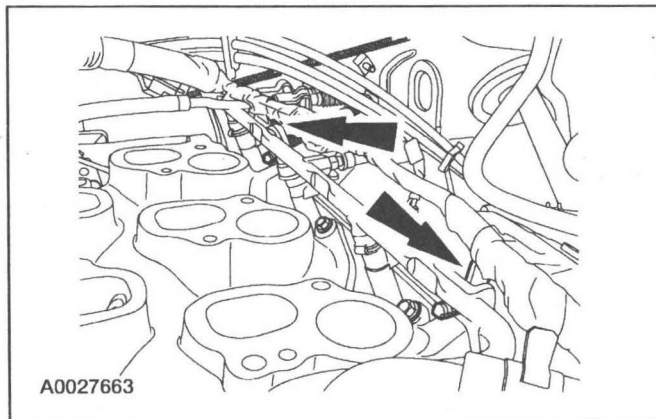

13. **NOTE:** Left side shown, right side similar.
Connect the fuel injector electrical harness to the fuel injector supply manifold.

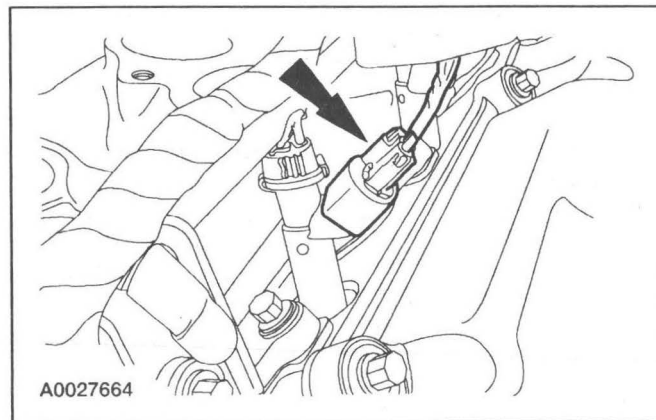

14. **NOTE:** One shown, all are similar.
Connect the fuel injector electrical connectors.

15. Install the upper intake manifold. For additional information, refer to Upper Intake Manifold in this section.

Intake Manifold —Spacer Assembly**Removal**

1. Remove the upper intake manifold. For additional information, refer to Upper Intake Manifold in this section.

100% SATISFACTION GUARANTEED

BUY IT NOW!

Click Here To Order

PayPal American Express Discover MasterCard VISA

IN-VEHICLE REPAIR (Continued)

2. Partially drain the cooling system. For additional information, refer to Section 303-03A.

3. Disconnect the throttle position (TP) sensor.

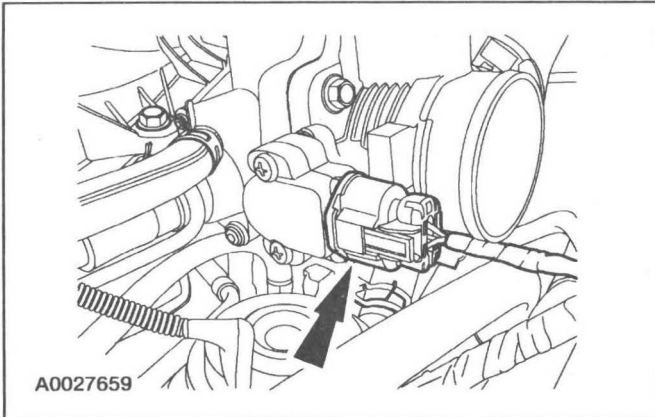

4. Disconnect the brake booster vacuum hose.

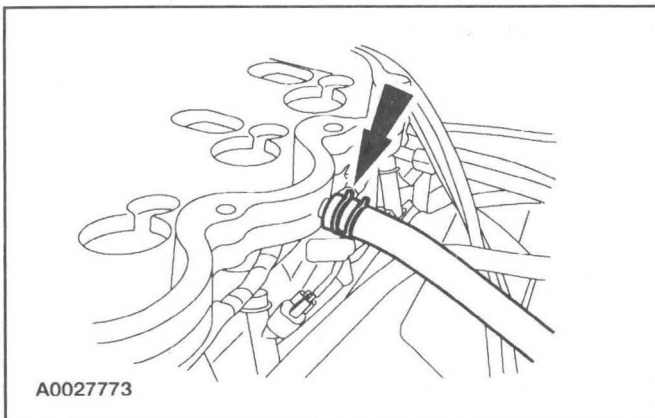

5. Disconnect the vapor management valve (VMV) hose.

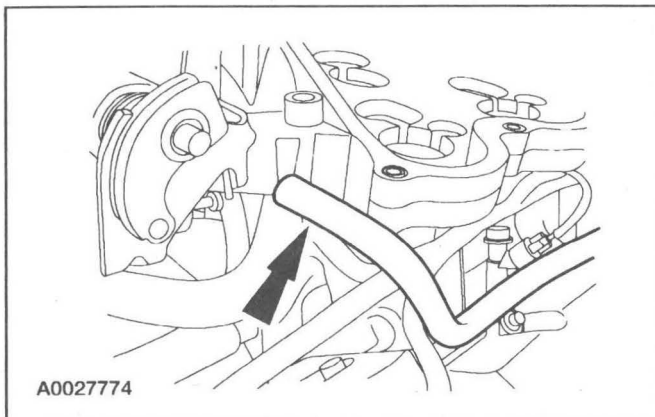

6. Disconnect the positive crankcase ventilation (PCV) hose.

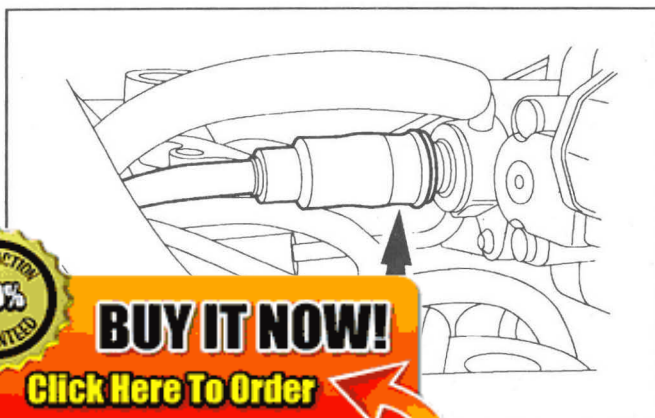

BUY IT NOW!

Click Here To Order



IN-VEHICLE REPAIR (Continued)

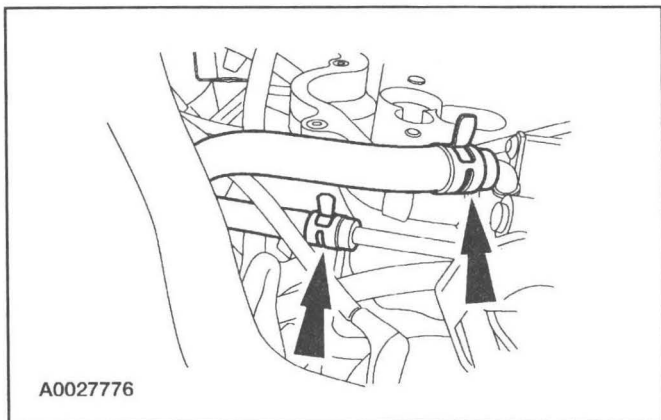

7. Disconnect the heater water hoses at the intake manifold.

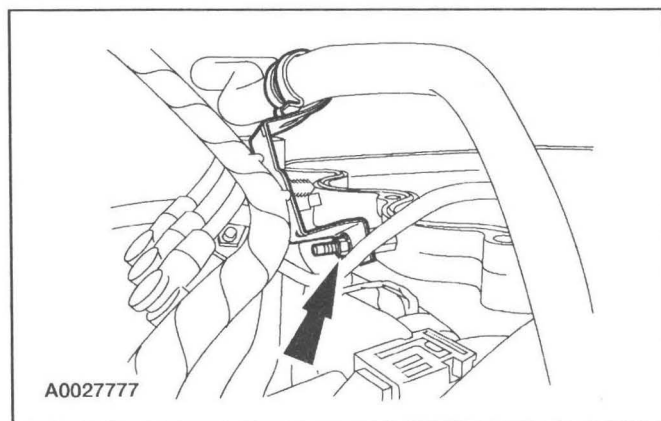

8. Remove the heater hose bracket at the intake manifold.

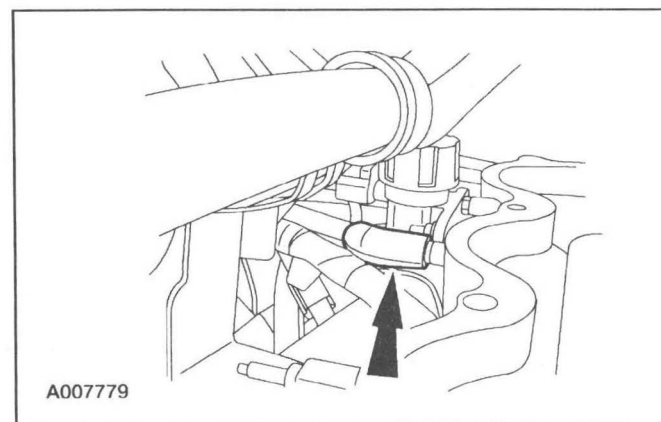

9. Disconnect the intake manifold vacuum connector.

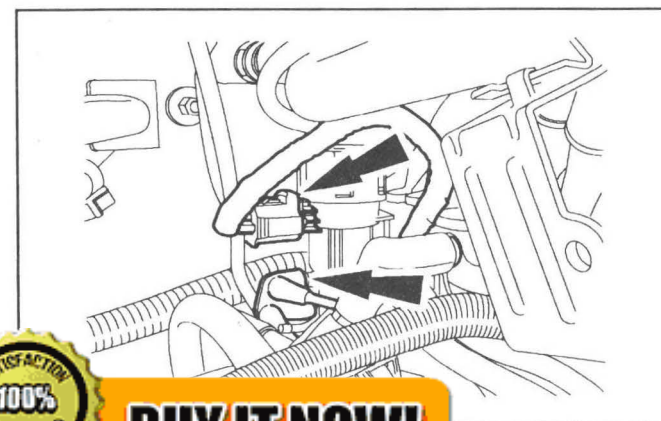

10. Disconnect the EGR solenoid electrical and vacuum connectors.



BUY IT NOW!

Click Here To Order



IN-VEHICLE REPAIR (Continued)

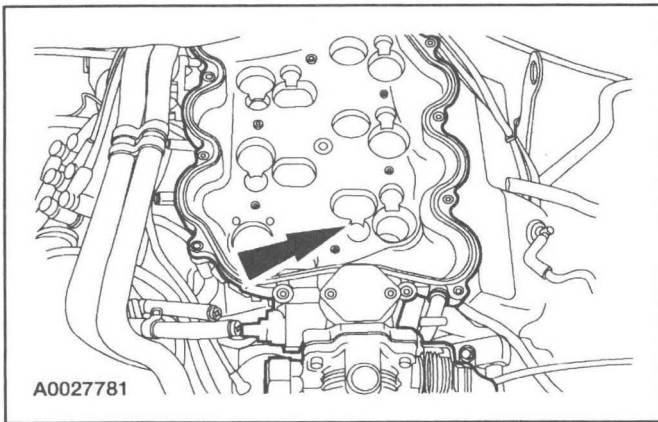

11. Remove the eight bolts and the intake manifold spacer assembly.

Installation

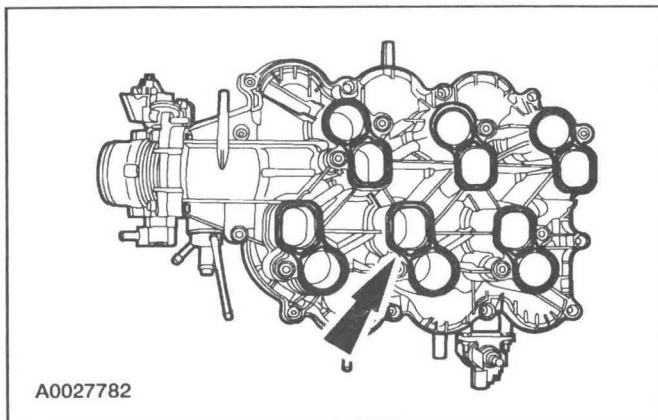

1. Inspect the intake manifold spacer assembly mounting gaskets. Install new gaskets, if necessary.

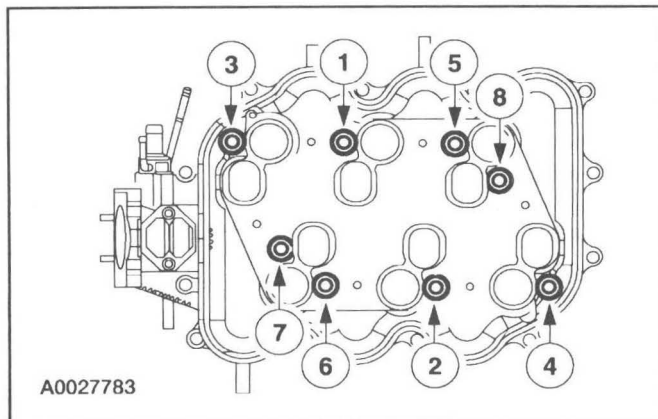

2. Install the intake manifold spacer assembly. Tighten the bolts in two steps in the sequence shown.
 - Step 1 — Tighten to 6 Nm (53 lb-in).
 - Step 2 — Tighten to 10 Nm (89 lb-in).



3. Connect the EGR solenoid electrical and vacuum connectors.



BUY IT NOW!

Click Here To Order



IN-VEHICLE REPAIR (Continued)

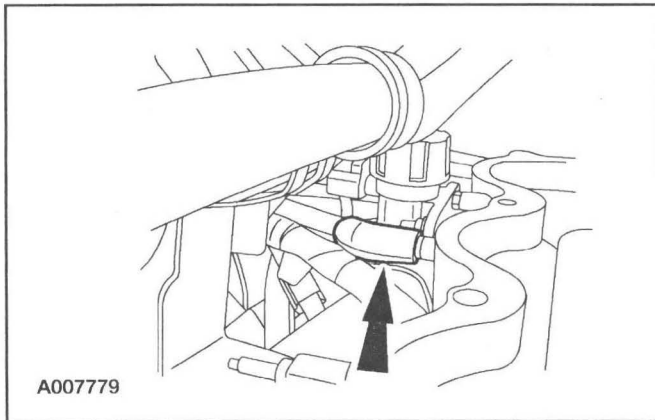

4. Connect the intake manifold vacuum connector.

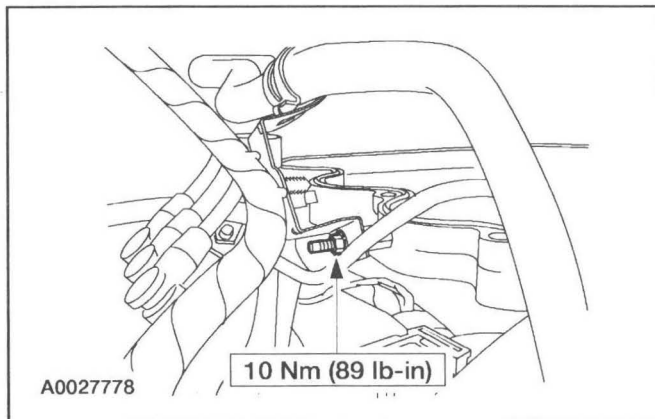

5. Install the heater hose bracket at the intake manifold.

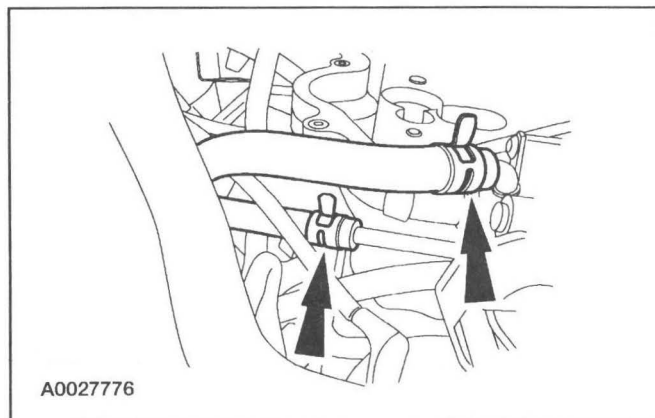

6. Connect the heater water hoses at the intake manifold.

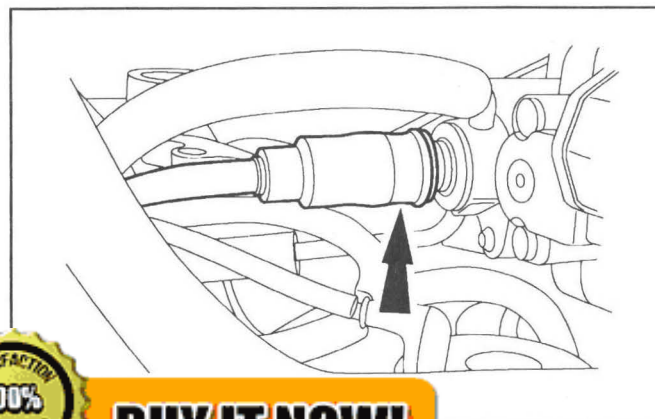

7. Connect the positive crankcase ventilation (PCV) hose.



BUY IT NOW!

Click Here To Order



IN-VEHICLE REPAIR (Continued)

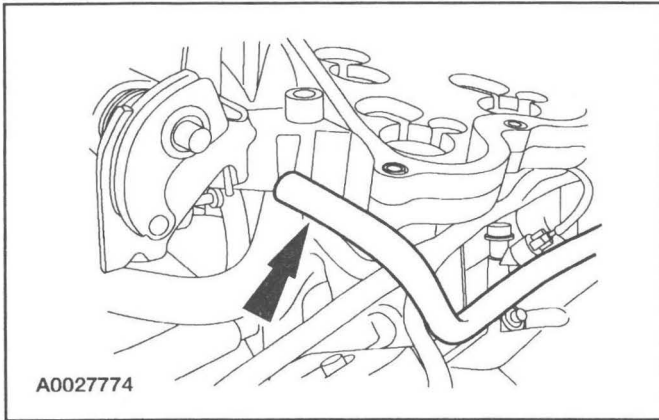

8. Connect the vapor management valve (VMV) hose.

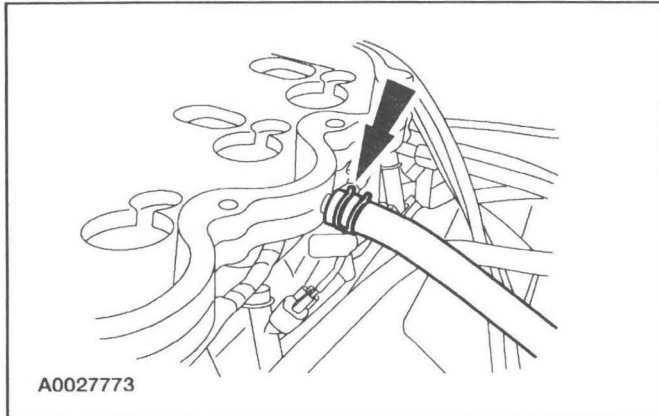

9. Connect the brake booster vacuum hose.

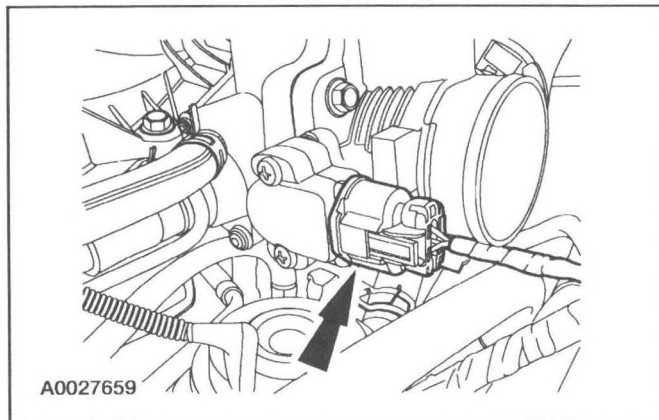

10. Connect the throttle position (TP) sensor.

11. Fill the cooling system. For additional information, refer to Section 303-03A.
12. Install the upper intake manifold. For additional information, refer to Upper Intake Manifold in this section.

100% FACTORY GUARANTEED

BUY IT NOW!

Click Here To Order

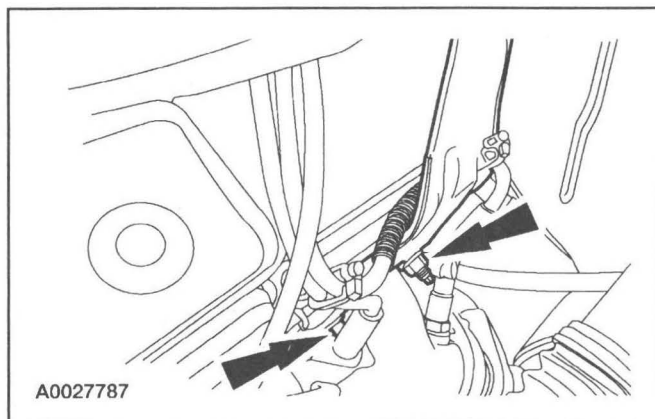
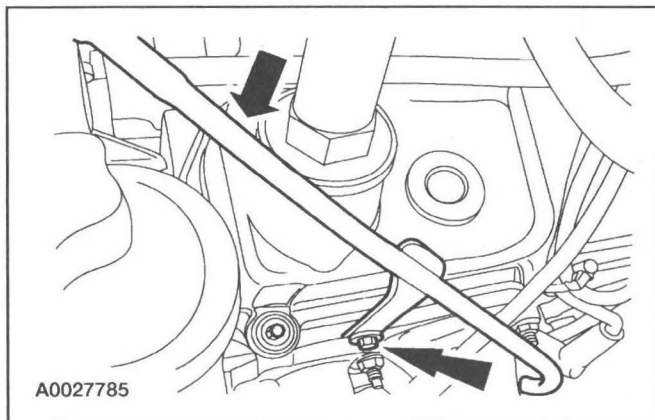
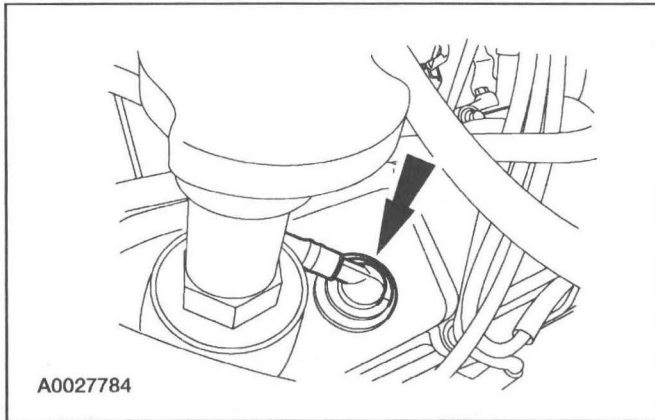
IN-VEHICLE REPAIR (Continued)**Valve Cover LH****Removal**

1. Remove the positive crankcase ventilation (PCV) tube.
2. Remove the bolt and position the oil level indicator and tube assembly out of the way.
3. Remove the nuts and the engine lifting eye.

**BUY IT NOW!****Click Here To Order**

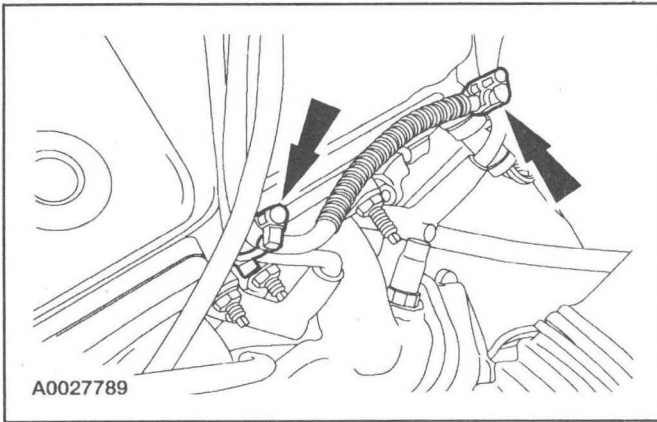
IN-VEHICLE REPAIR (Continued)

4. Disconnect the spark plug wire holders.

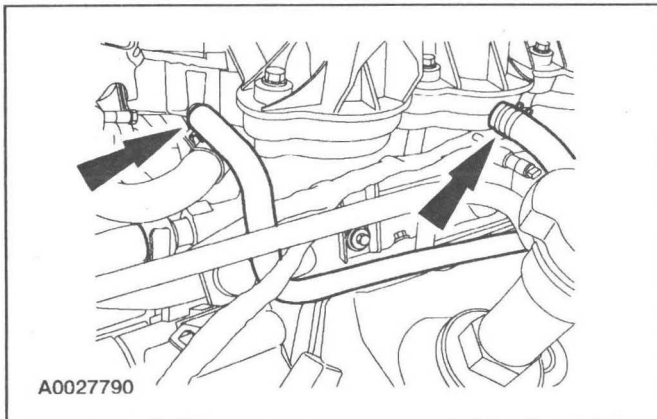

5. Disconnect the vapor hose and the brake vacuum hose and position out of the way.

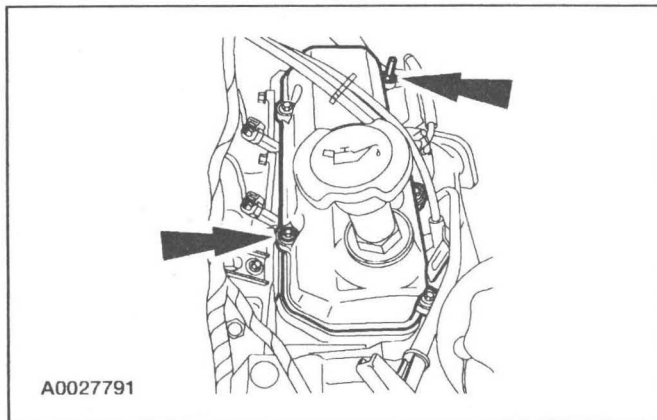

6. Remove the bolts, the stub bolts and the LH valve cover.

7. Remove and discard the LH valve cover gasket (6584).

Installation

1. Install a new valve cover gasket.

**BUY IT NOW!****Click Here To Order**

IN-VEHICLE REPAIR (Continued)

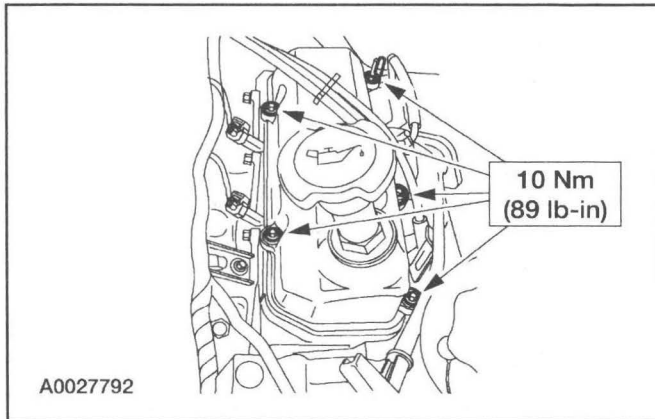

2. Install the valve cover, the bolts and the stud bolts.

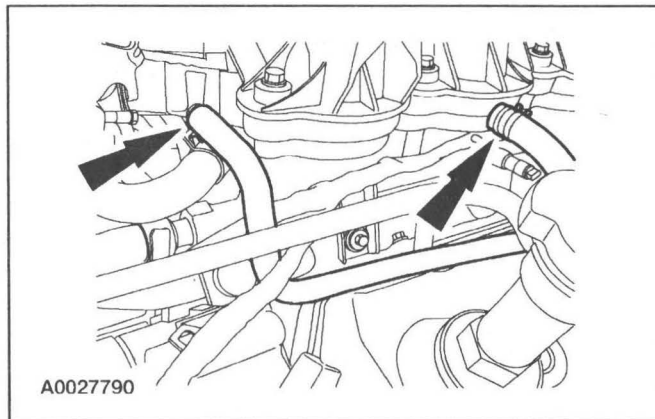

3. Connect the vapor hose and the brake vacuum hose.

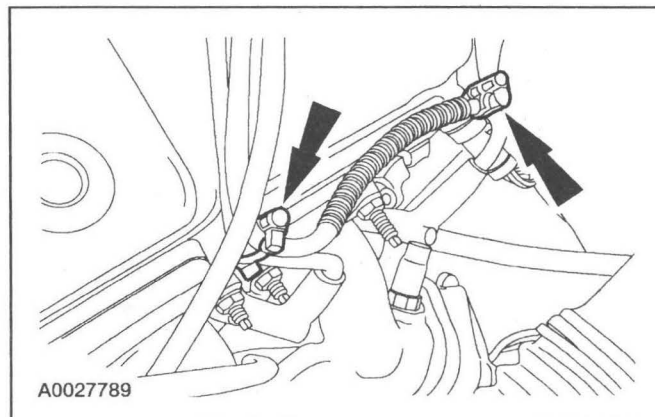

4. Connect the spark plug wire holders.

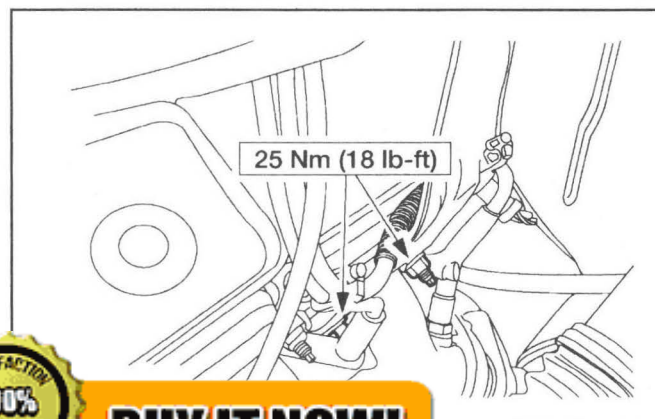

5. Install the engine lifting eye and the nuts.



BUY IT NOW!

Click Here To Order



IN-VEHICLE REPAIR (Continued)

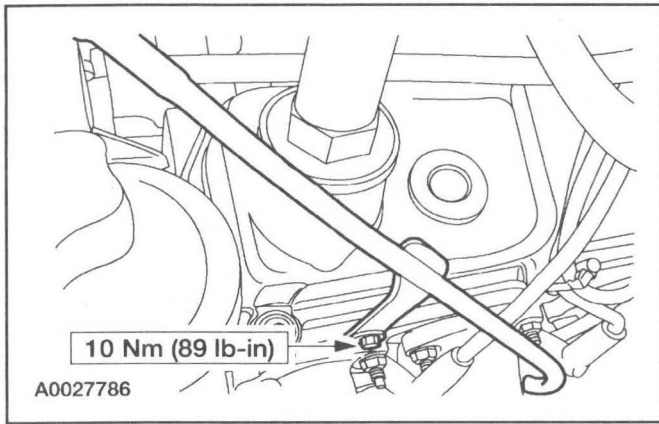

6. Position the oil level indicator and tube assembly and install the bolt.

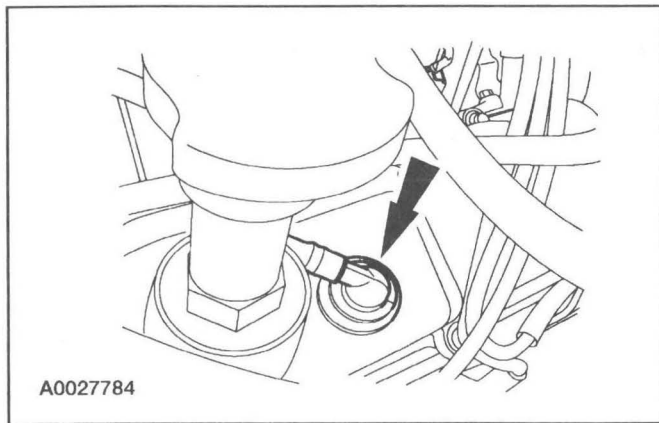

7. Install the positive crankcase ventilation (PCV) hose.

Valve Cover RH

Removal

1. Remove the ignition coil. For additional information, refer to Section 303-07A.
2. Remove the nuts and the engine lifting eye.

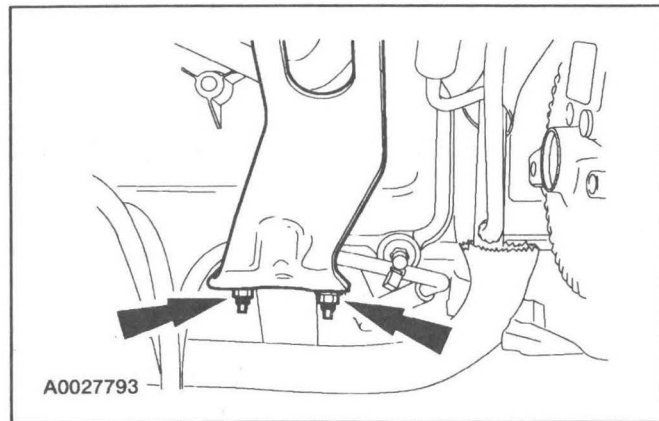

BUY IT NOW!

Click Here To Order



IN-VEHICLE REPAIR (Continued)

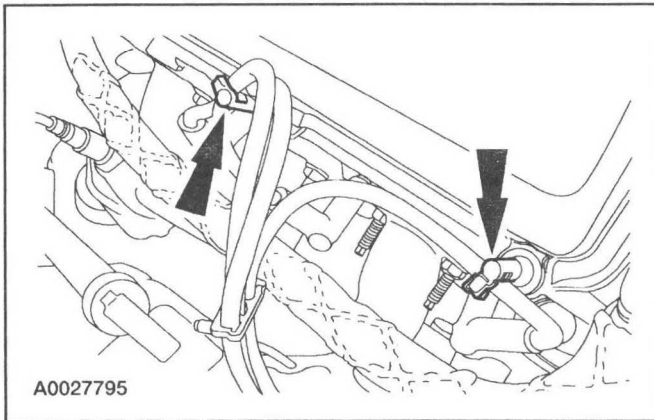

3. Disconnect the spark plug wire holders.

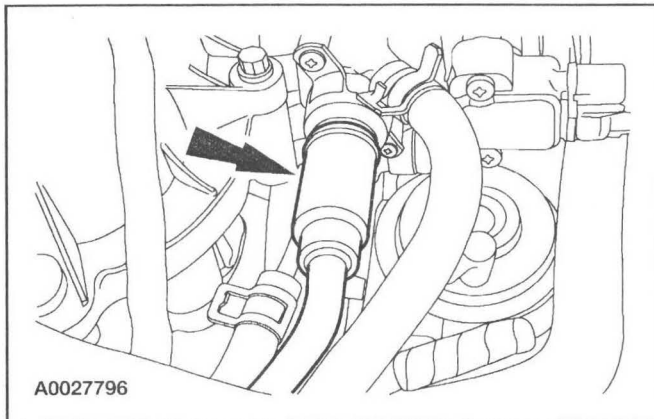

4. Disconnect the positive crankcase ventilation (PCV) hose at the intake manifold.

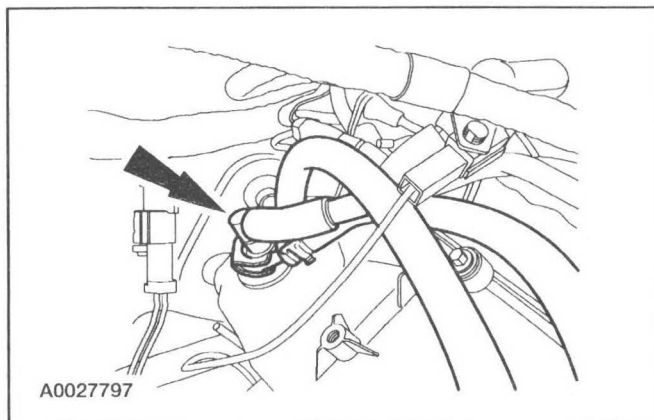

5. Detach the positive crankcase ventilation (PCV) valve/heater water hose assembly and position aside.

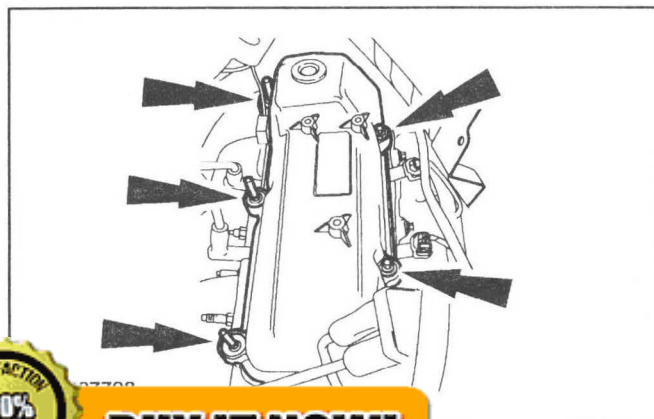

6. Remove the bolts, the stud bolts and the RH valve cover.

7. Remove and discard the RH valve cover gasket.



BUY IT NOW!

Click Here To Order



IN-VEHICLE REPAIR (Continued)**Installation**

1. Install a new valve cover gasket.
2. Install the RH valve cover, the stud bolts, and the bolts.
3. Install the positive crankcase ventilation (PCV) valve/heater hose assembly.
4. Connect the positive crankcase ventilation (PCV) hose at the intake manifold.

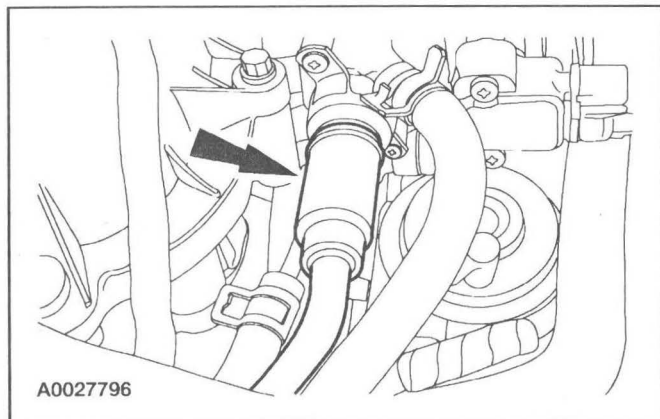
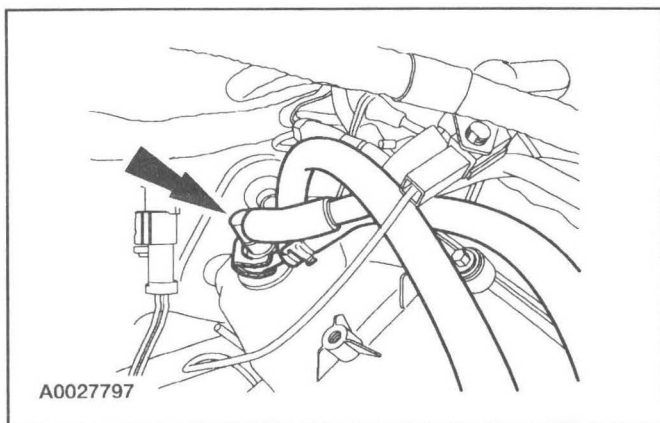
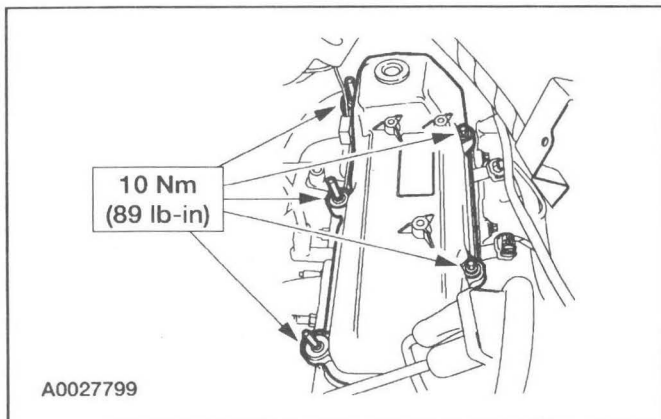
**BUY IT NOW!****Click Here To Order**

IN-VEHICLE REPAIR (Continued)

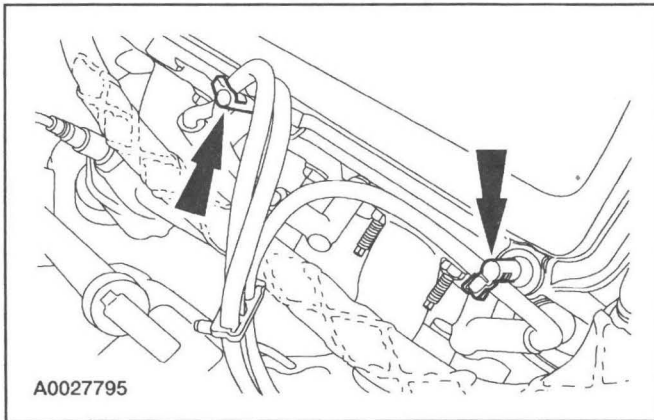

5. Connect the spark plug wire holders.

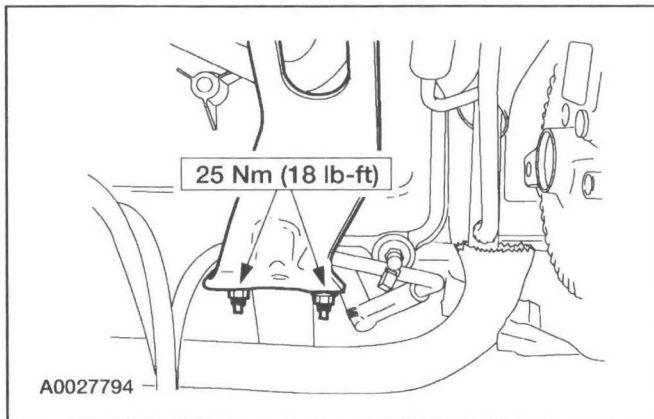

6. Install the engine lifting eye and nuts.

7. Install the ignition coil. For additional information, refer to Section 303-07A.

Crankshaft Pulley

Special Tool(s)

<p>ST1286-A</p>	<p>Remover, Crankshaft Vibration Damper 303-009 (T58P-6316-D)</p>
<p>ST1378-A</p>	<p>Remover, Crankshaft Vibration Damper 303-176 (T82L-6316-B)</p>

Special Tool(s)

<p>ST1387-A</p>	<p>Installer, Crankshaft Damper/Crankshaft Front Oil Seal 303-175 (T82L-6316-A)</p>
-----------------	---



BUY IT NOW!

Click Here To Order



IN-VEHICLE REPAIR (Continued)**Materials**

Item	Specification
Silicone Gasket and Sealant F7AZ-19554-EA or equivalent	WSE-M4G323-A4

Removal

1. Remove the drive belt. For additional information, refer to Section 303-05.
2. Remove the fan blade assembly. For additional information, refer to Section 303-03A.
3. Disconnect the battery ground cable. For additional information, refer to Section 414-01.
4. Raise the vehicle on a hoist. For additional information, refer to Section 100-02.
5. Remove the crankshaft pulley bolt.
6. Using the special tool, remove the crankshaft pulley (6B321).

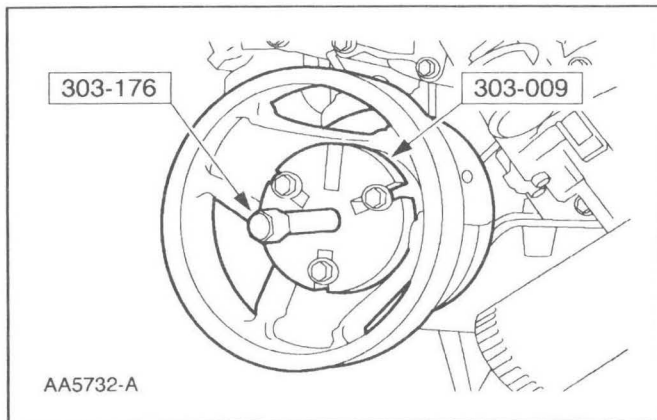
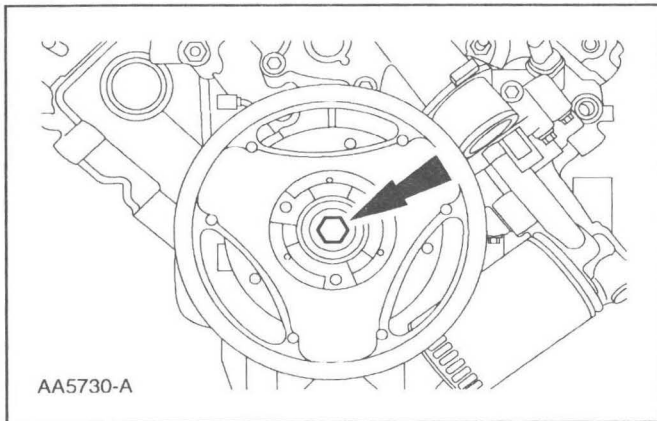
**BUY IT NOW!****Click Here To Order**

PayPal

MasterCard

Discover

American Express

MasterCard

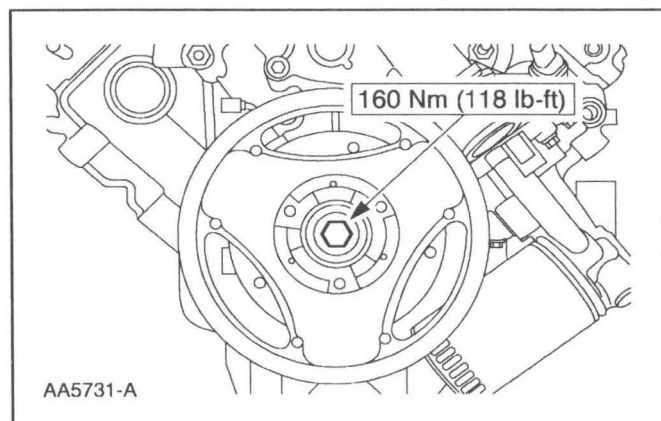
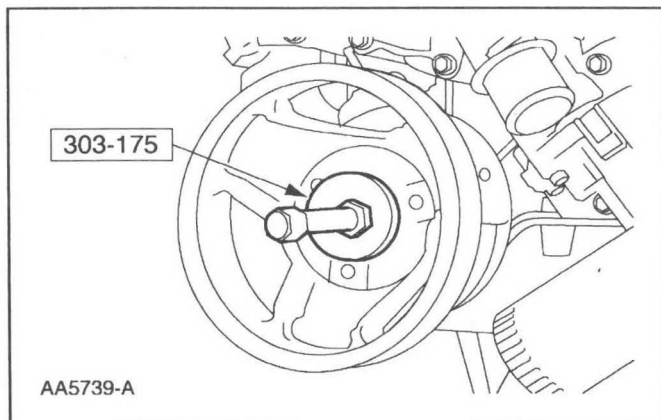

VISA

IN-VEHICLE REPAIR (Continued)**Installation**

1. Apply a bead of silicone gasket and sealant to the keyway in the crankshaft damper and use the special tool to install the crankshaft damper.
2. Install the bolt.
3. Lower the vehicle.
4. Connect the battery ground cable. For additional information, refer to Section 414-01.
5. Install the fan blade assembly. For additional information, refer to Section 303-03A.
6. Install the drive belt. For additional information, refer to Section 303-05.

**BUY IT NOW!****Click Here To Order**

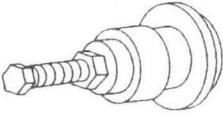
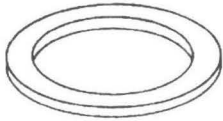
IN-VEHICLE REPAIR (Continued)**Crankshaft Front Oil Seal****Special Tool(s)**

 <p>ST1328-A</p>	<p>Installer, Front Cover Oil Seal 303-335 (T88T-6701-A)</p>
 <p>ST1379-A</p>	<p>Installer, Crankshaft Front Oil Seal 303-474 (T94P-6701-AH)</p>
 <p>ST1385-A</p>	<p>Remover, Oil Seal 303-409 (T92C-6700-CH)</p>

Materials

Item	Specification
Super Premium SAE 5W-20 Engine Oil XO-5W20-QSP or equivalent	WSS-M2C153-H

Removal

1. Remove the crankshaft damper. For additional information, refer to Crankshaft Pulley in this section.
2. Use the special tool to remove the crankshaft front seal. Discard the crankshaft front seal.

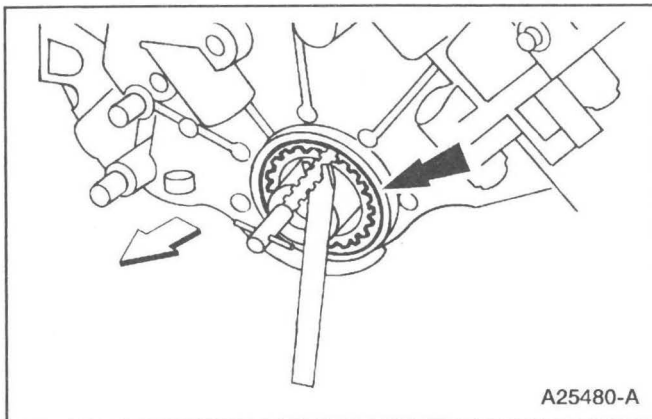
**Installation**

1. Inspect the crankshaft damper and the engine front cover for damage that may cause the crankshaft front seal to fail.

100% SATISFACTORY GUARANTEED

BUY IT NOW!

Click Here To Order

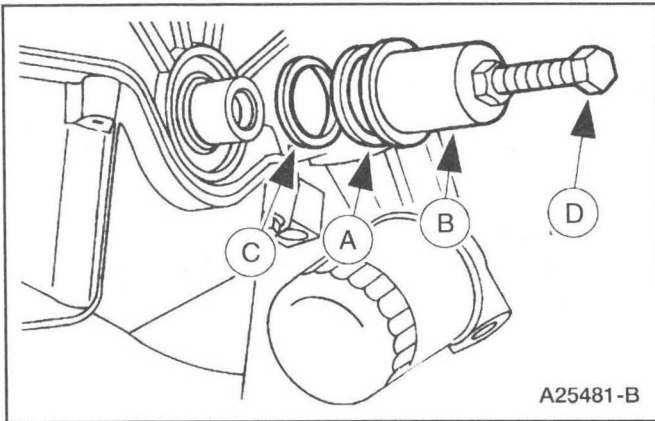

IN-VEHICLE REPAIR (Continued)

- NOTE:** Lubricate parts with engine oil before assembly.

Use the (A) Front Crankshaft Seal Replacer (spacer), the (B) Front Crankshaft Seal Installer/Cover Aligner and the (D) Vibration Damper Remover Adapter to install the (C) crankshaft front seal.

- Install the crankshaft pulley. For additional information refer to Crankshaft Pulley in this section.

Engine Front Cover**Materials**

Item	Specification
Metal Surface Cleaner F4AZ-19A536-RA or equivalent	WSE-M5B392-A
Silicone Gasket and Sealant F7AZ-19554-EA or equivalent	WSE-M4G323-A4
Super Premium SAE 5W-20 Engine Oil XO-5W20-QSP or equivalent	WSS-M2C153-H

Removal

- Disconnect the battery ground cable. For additional information, refer to Section 414-01.
- Drain the engine cooling system. For additional information, refer to Section 303-03A.
- Remove the engine air cleaner (ACL). For additional information, refer to Section 303-12.
- Remove the upper radiator hose, the fan shroud and the lower radiator hose. For additional information, refer to Section 303-03A.

100% SATISFACTION GUARANTEED

BUY IT NOW!

Click Here To Order

IN-VEHICLE REPAIR (Continued)

5. Disconnect camshaft position sensor electrical connector.
6. Raise and support the vehicle. For additional information, refer to Section 100-02.
7. Remove the oil pan drain plug and drain the engine oil.

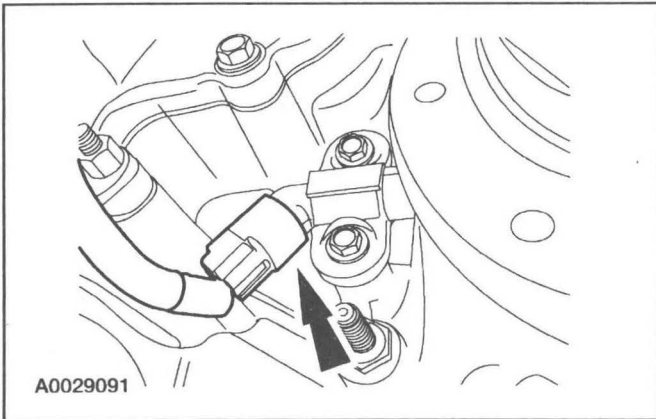
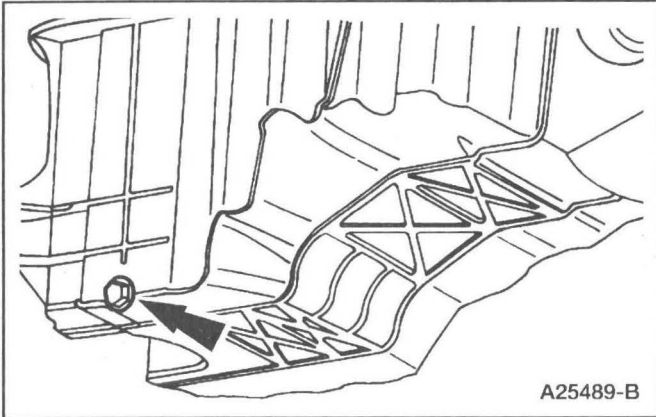

8. Disconnect the crankshaft sensor electrical connector.

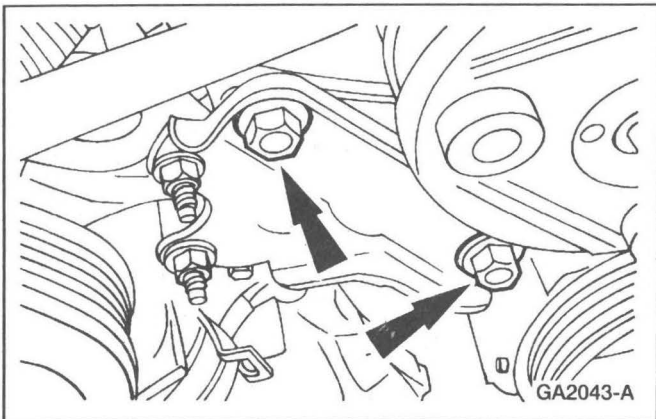

9. Position the engine wiring harness aside.
10. Remove the power steering pump bracket bolts.



BUY IT NOW!

Click Here To Order



IN-VEHICLE REPAIR (Continued)

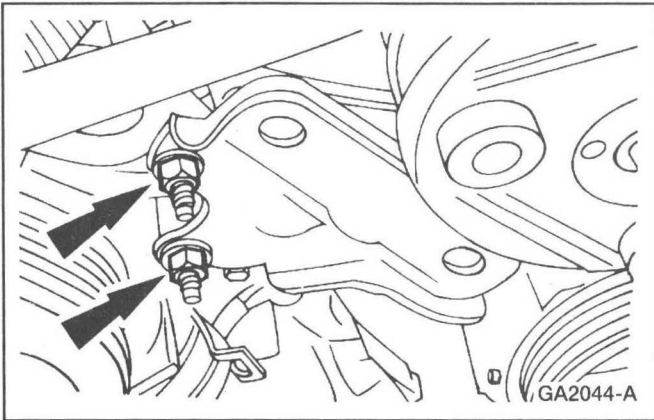

11. Remove the nuts and remove the power steering pump bracket.

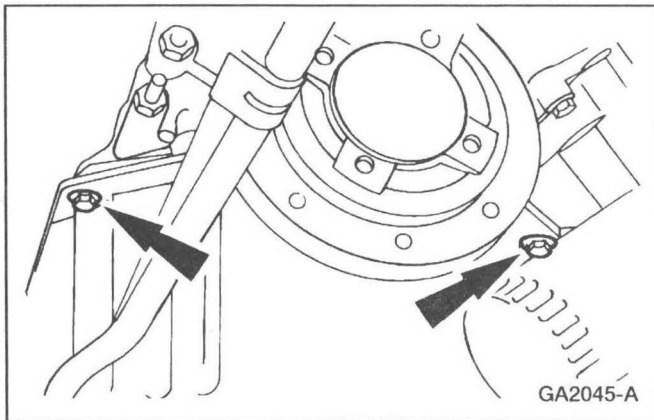

12. Remove the crankshaft pulley. For additional information, refer to Crankshaft Pulley in this section.

13. Remove the four bolts.

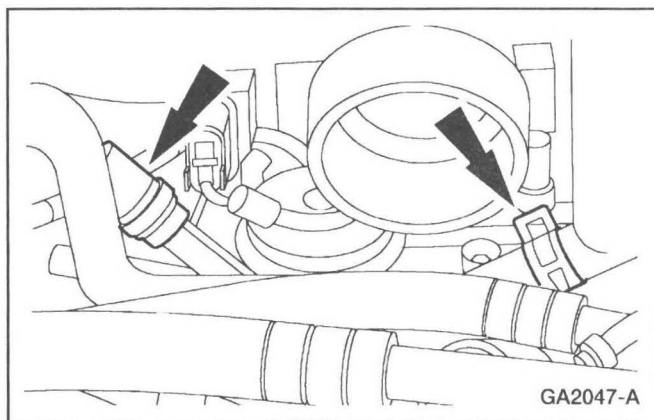

14. Lower the vehicle.

15. Remove the heater water outlet tube hoses.

100% SATISFACTION GUARANTEED

BUY IT NOW!

Click Here To Order

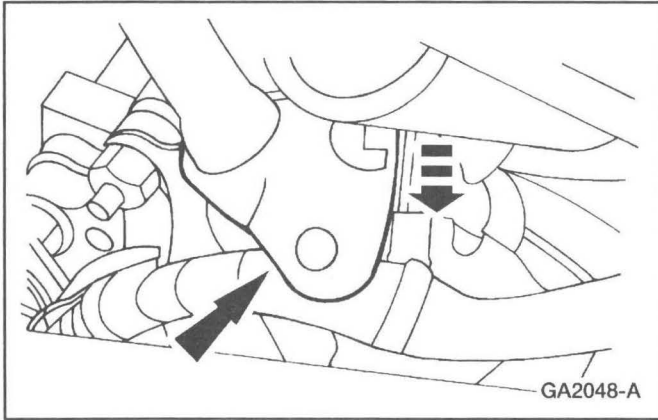
IN-VEHICLE REPAIR (Continued)

16. Detach the wiring harness from the outlet tube and position aside.

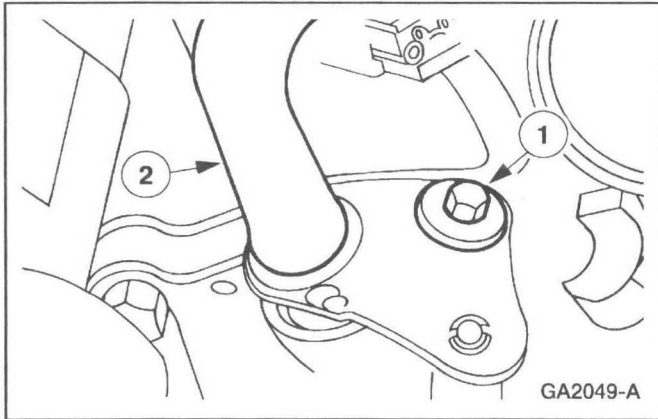

17. Remove the heater water outlet tube.
- 1 Remove the bolt.
 - 2 Remove the heater water outlet tube.

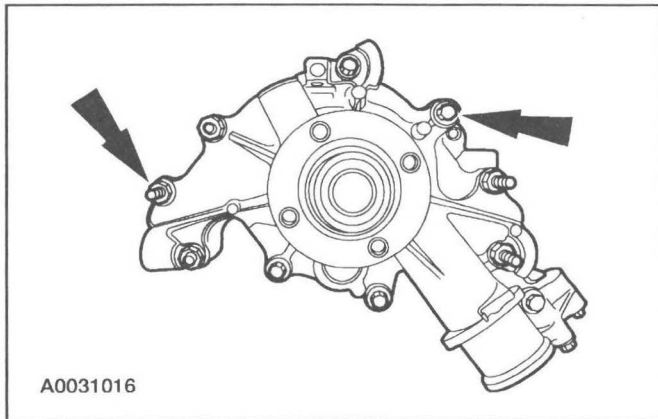

18. Remove the camshaft synchronizer. For additional information, refer to Section 303-14.

19. Remove the nuts and bolts. Remove the water pump.

20. Remove the crankshaft front oil seal. For additional information, refer to Crankshaft Front Oil Seal in this section.



BUY IT NOW!

Click Here To Order



IN-VEHICLE REPAIR (Continued)

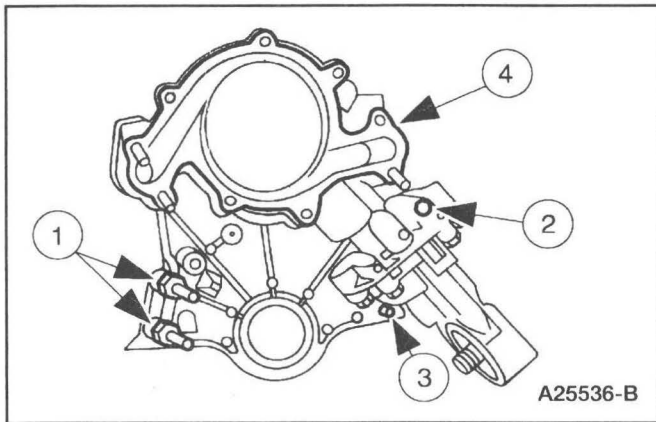

21. Remove the front cover and the front cover gasket.
 - 1 Remove the stud bolts.
 - 2 Remove the bolt.
 - 3 **CAUTION: The cap screw is hidden; make sure to remove it or the front cover will be damaged.**
Remove the cap screw.
 - 4 Slide the front cover and the front cover gasket off the dowels. Discard the engine front cover gasket.

Installation

1. **CAUTION: In order to prevent foreign material from contaminating the engine block or the engine front cover it is necessary to seal the coolant and oil passages of both components. Failure to follow these directions will result in engine damage.**

CAUTION: Do not use a surface conditioning pad or any other type of fibrous abrasive disc to clean the gasket surfaces. Failure to follow these directions will result in engine damage.

Clean and inspect the engine block and front cover as follows:

- Pack the exposed portion of the oil pan with shop towels.
- Plug the oil and coolant passages.
- Clean the gasket surfaces.
- Clean all surfaces requiring gasket sealant with metal surface cleaner.
- Using compressed air, remove any remaining foreign material from the engine block and engine front cover.
- Remove the shop towels from the oil pan.
- Remove the plugs or seals from the engine block and engine front cover.

**SATISFACTORY
100%
GUARANTEED**

BUY IT NOW!

Click Here To Order

IN-VEHICLE REPAIR (Continued)

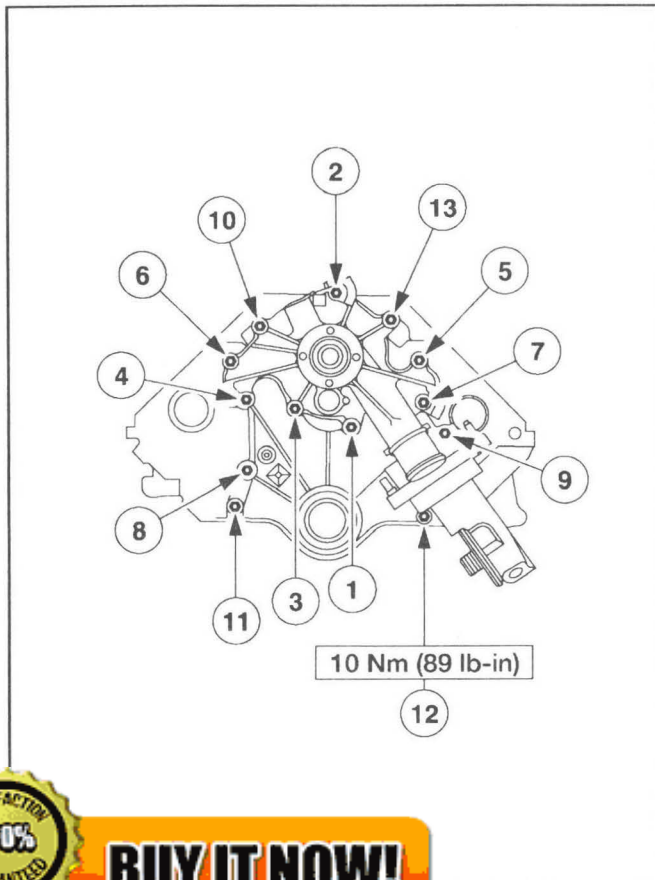
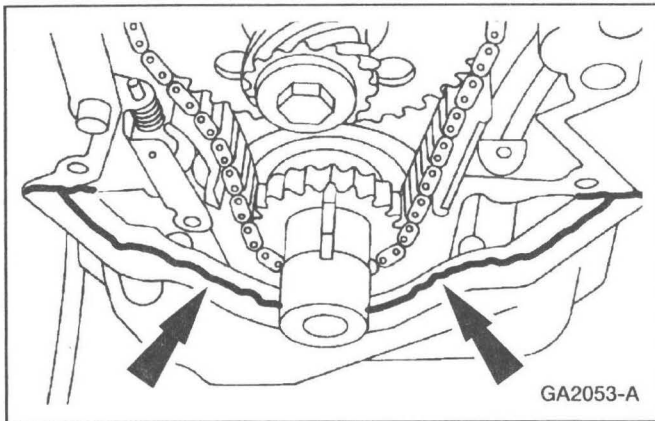
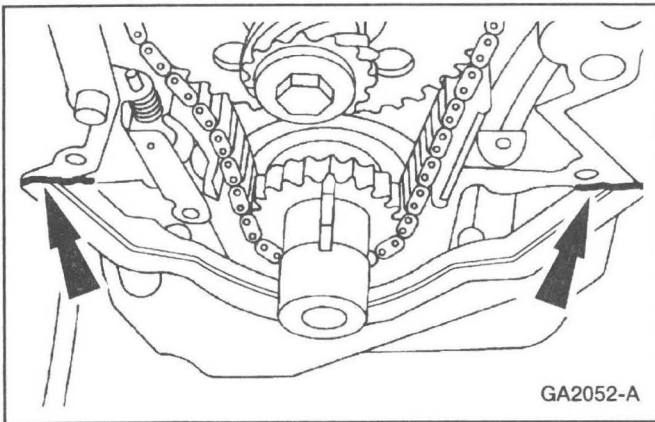

2. Apply a small amount of silicone gasket and sealant as shown on the oil pan to block parting location.

3. Install the front cover gasket and apply silicone gasket and sealant as shown on the oil pan.

4. **⚠ CAUTION: Make sure the capscrew is installed. If it is missed, an engine oil leak may occur.**

NOTE: The number 12 position is not part of the staged torque.

Install the front cover. Install water pump with a new gasket.

- Tighten the front cover bolts in the sequence shown in two stages:
- Stage 1: Install studs and tighten to 7 Nm (62 lb-in).
- Stage 2: Tighten the bolts, stud bolts and nuts to 28 Nm (21 lb-ft).



BUY IT NOW!

Click Here To Order



IN-VEHICLE REPAIR (Continued)

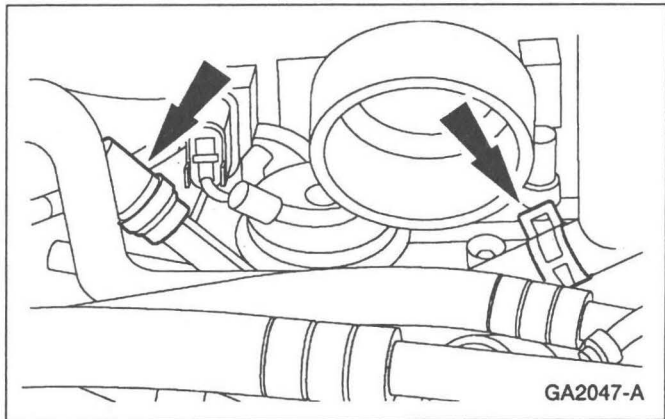
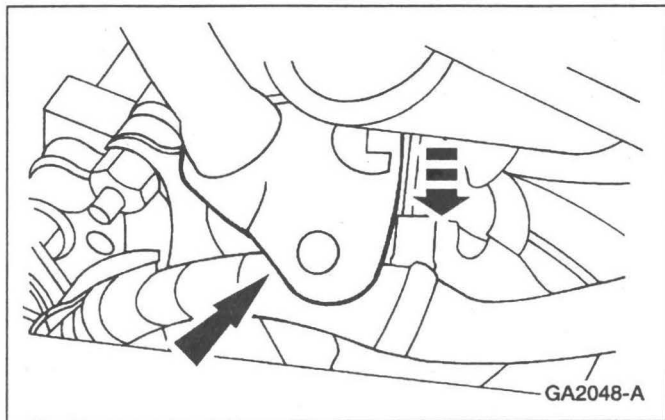
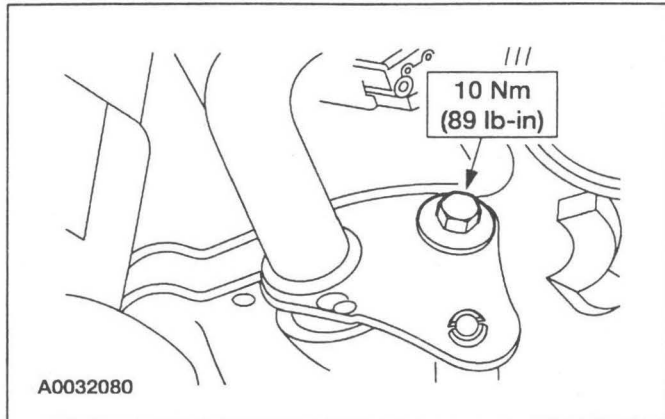

5. Install the camshaft synchronizer. For additional information, refer to Section 303-14.

6. Install the heater water outlet tube.

7. Attach the wiring harness to the outlet tube.

8. Install the heater water outlet tube hoses.

9. Raise and support the vehicle.

100% SATISFACTION GUARANTEED

BUY IT NOW!

Click Here To Order

PayPal Discover Discover MasterCard VISA

IN-VEHICLE REPAIR (Continued)

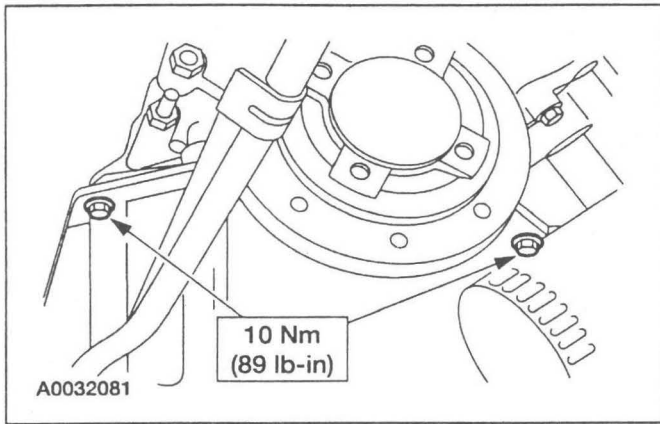

10. Install the four front oil pan-to-engine front cover bolts.

11. Install the crankshaft front oil seal. For additional information, refer to Crankshaft Front Oil Seal in this section.

12. Install the crankshaft pulley and the crankshaft damper. For additional information, refer to the Crankshaft Pulley procedure in this section.

13. Install the power steering pump bracket. Install the nuts.

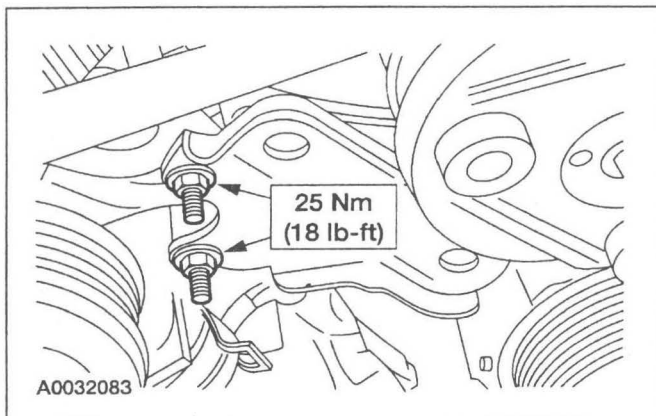

14. Install the power steering pump bracket bolts.

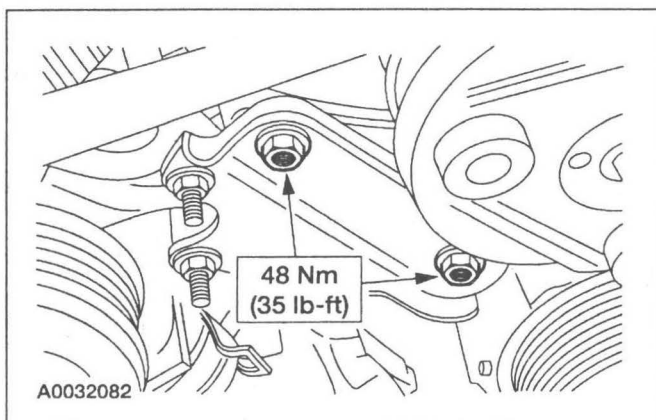

BUY IT NOW!

Click Here To Order

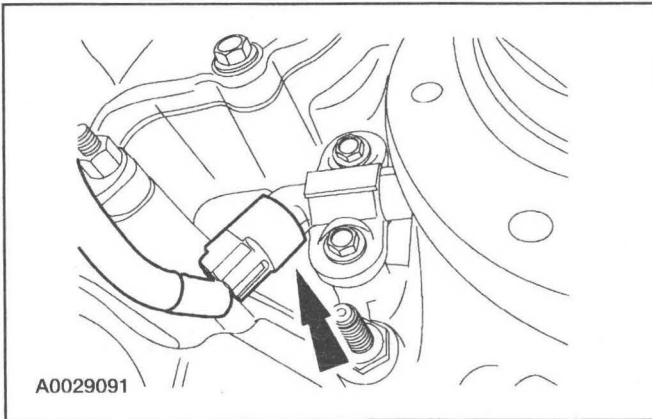

IN-VEHICLE REPAIR (Continued)

15. Connect the crankshaft sensor electrical connector.
16. Install the crankshaft sensor shield.
17. Lower the vehicle.
18. Connect the battery ground cable. For additional information, refer to Section 414-01.
19. Install the lower radiator hose, the fan shroud and the upper radiator hose. For additional information, refer to Section 303-03A.
20. Install the engine air cleaner. For additional information, refer to Section 303-12.
21. Refill the cooling system. For additional information, refer to Section 303-03A.
22. Install the oil pan drain plug and fill the engine with clean engine oil.
23. Start the engine and check for leaks.

Valve Spring**Special Tool(s)**

	Compressor, Valve Spring 303-163 (T81P-6513-A)
--	---

**BUY IT NOW!****Click Here To Order**

IN-VEHICLE REPAIR (Continued)**Materials**

Item	Specification
Super Premium SAE 5W-20 Engine Oil XO-5W20-QSP or equivalent	WSS-M2C153-H

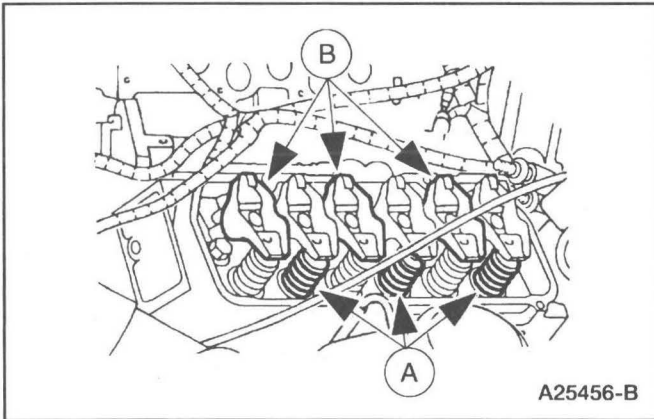
**Removal**

1. Remove the valve cover. For additional information, refer to Valve Cover LH and Valve Cover RH in this section.
2. Rotate the crankshaft until the piston for the valve being worked on is at the top of its stroke with both the (A) intake valve and the (B) exhaust valve closed.
3. Hold the valve in the cylinder head.
 - Remove the spark plug. For additional information, refer to Section 303-07A.
 - Apply a minimum of 965 kPa (140 psi) of compressed air to the cylinder.

100% SATISFACTION GUARANTEED

BUY IT NOW!

Click Here To Order

IN-VEHICLE REPAIR (Continued)

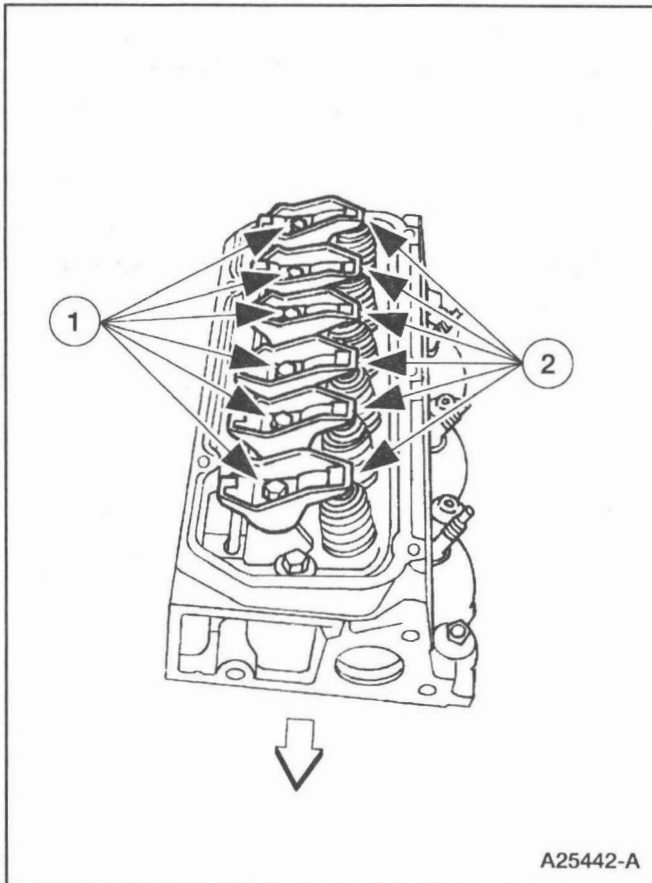

4.  **CAUTION:** If the components are to be reinstalled, they must be installed in the same position. Mark the components for location.

 **CAUTION:** If a valve drops into the cylinder, remove the cylinder head. For additional information refer to **Cylinder Head** in this section.

Remove the rocker arms.

- 1 Remove the bolts.
- 2 Remove the rocker arms.

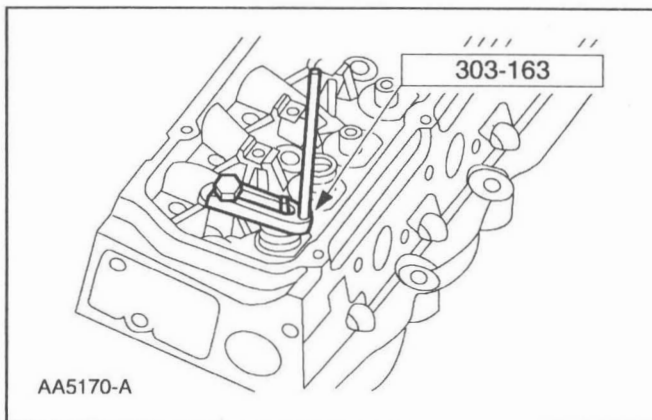

5. Using the special tool, compress the valve spring.

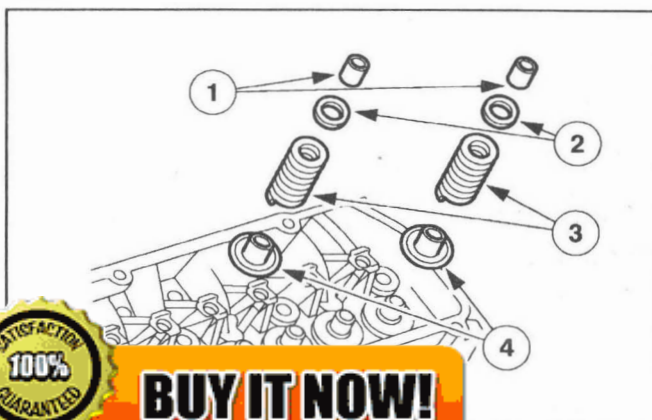

6. Remove the following:
- 1 Remove the valve spring retainer key.
 - 2 Remove the valve spring retainer.
 - 3 Remove the valve spring.
 - 4 Remove and discard the valve stem seal and seat.



BUY IT NOW!

Click Here To Order



Alphabetical Index

1

1-2 Accumulator307-01B-158

2

2-3 Accumulator307-01B-159

A

A/C Cycling Switch 412-03-36
 Acceleration Control, Description and Operation 310-02-2
 Acceleration Control, Diagnosis and Testing 310-02-3
 Inspection and Verification..... 310-02-3
 Symptom Chart 310-02-3
 Accelerator Cable — 4.2L 310-02-6
 Accelerator Cable — 4.6L 310-02-8
 Accelerator Cable — 5.4L 310-02-10
 Accelerator Cable — 5.4L Lightning 310-02-12
 Accelerator Pedal — Adjustable..... 310-02-5
 Accelerator Pedal — Fixed 310-02-4
 Accessory Drive, Description and Operation 303-05-2
 Accessory Drive, Diagnosis and Testing 303-05-4
 Inspection and Verification..... 303-05-4
 Symptom Chart 303-05-5
 Component Tests 303-05-6
 Accessory Drive — Lightning 303-05-3
 Actuator — A/C Electronic Blend Door 412-04-8
 Adapter 206-04-8
 Air Bag Disposal — Deployed..... 501-20B-119
 Air Bag Disposal — Driver, Undeployed, Scrapped
 Vehicle 501-20B-121
 Remote Deployment 501-20B-121
 Air Bag Disposal — Passenger, Undeployed,
 Scrapped Vehicle 501-20B-123
 Air Bag Disposal — Undeployed Inoperative 501-20B-120
 Air Bag Supplemental Restraint System (SRS),
 Description and Operation..... 501-20B-2
 Air Bag Supplemental Restraint System (SRS),
 Diagnosis and Testing 501-20B-5
 Diagnosing Customer Concerns Without Hard
 DTCs 501-20B-5
 Diagnosing Customer Concerns with Hard DTCs 501-20B-5
 Activation Procedure..... 501-20B-6
 Deactivation Procedure 501-20B-6
 Inspection and Verification..... 501-20B-7
 Pinpoint Tests 501-20B-7
 Component Tests 303-12-10

Air Cleaner — — Outlet 303-12-9
 Air Cleaner — Lightning 303-12-12
 Air Cleaner Element 303-12-13
 Air Cleaner Element — Lightning..... 303-12-14
 Air Cleaner Outlet Pipe — — 4.2L 303-12-7
 Air Cleaner Outlet Pipe — Resonator, 4.6L and 5.4L 303-12-8
 Air Conditioning..... 412-03-9
 Air Conditioning (A/C) Clutch Air Gap Adjustment 412-00-79
 Air Conditioning (A/C) System Check — Retail
 Procedure 412-00-65
 Air Conditioning (A/C) System Flushing 412-00-86
 Air Conditioning (A/C) System Recovery,
 Evacuation and Charging 412-00-83
 Air Conditioning Line (Peanut) Fitting 412-00-72
 Air Conditioning System..... 412-03-2
 Air Distribution, Description and Operation 412-01-2
 Air Distribution, Diagnosis and Testing 412-01-4
 Antenna..... 415-02-2
 Anti-Lock Brake System (ABS) Module 206-09B-50
 Anti-Lock Control, Description and Operation 206-09A-2
 Anti-Lock Control, Description and Operation 206-09B-2
 Anti-Lock Control, Diagnosis and Testing 206-09A-2
 Inspection and Verification..... 206-09A-2
 Principles of Operation 206-09A-2
 Symptom Chart 206-09A-4
 Pinpoint Tests 206-09A-9
 Anti-Lock Control, Diagnosis and Testing 206-09B-2
 Principles of Operation 206-09B-2
 Inspection and Verification — Drive Cycle Test 206-09B-3
 Inspection and Verification — Scan Tool
 Communications Check 206-09B-3
 Symptom Chart 206-09B-6
 Pinpoint Tests 206-09B-8
 Component Test — Intermittent Failures 206-09B-47
 Anti-Theft 419-01-2
 Inspection and Verification..... 419-01-3
 Symptom Chart 419-01-5
 Pinpoint Tests 419-01-6
 Anti-Theft — PATS 419-01-2
 Apply Components 307-01B-18
 Arm — Lower, Removal and Installation 204-01A-5
 Arm — Lower, Removal and Installation 204-01B-11
 Arm — Upper, Removal and Installation..... 204-01A-9
 Arm — Upper, Removal and Installation..... 204-01B-7
 Audio System, Description and Operation 415-01-2
 Audio System, Diagnosis and Testing 415-00-2
 Inspection and Verification..... 415-00-2
 Symptom Chart 415-00-3
 Pinpoint Tests 415-00-6
 Audio System, Diagnosis and Testing 415-01-3
 Audio Unit..... 415-01-3
 Autolamps 417-01-16
 Inspection and Verification..... 417-01-16

100% SATISFACTION GUARANTEED
BUY IT NOW!
 Click Here To Order



Alphabetical Index

Autolamps (Continued)

Pinpoint Tests	417-01-17
Symptom Chart	417-01-17
Automatic Transmission	307-01B-3
Auxiliary Transmission Fluid Cooler	307-02-8
Axle — Front Drive	205-03-25
Axle Assembly — Front Drive	205-03-15
Axle Housing, Removal and Installation	205-02A-39
Axle Housing, Removal and Installation	205-02B-38
Axle Housing, Removal and Installation	205-02C-43
Axle Housing Casting Porosity (Holes in Casting) Repair	205-00-25
Axle Housing Weld Leaks Repair	205-00-26
Axle Shaft, In-Vehicle Repair	205-02A-4
Axle Shaft, In-Vehicle Repair	205-02B-5
Axle Shaft — Disc Brake	205-02C-5
Axle Shaft — Drum Brake	205-02C-8
Axle Tube — Front	205-03-61

B

B-Pillar Trim Panel — SuperCrew	501-05-5
Backing Plate	206-02-12
Ball Joint	204-01B-25
Bar — Stabilizer	204-01B-25
Bar — Stabilizer, Lightning Vehicles	204-02-7
Bar and Link	204-01A-12
Barometric Pressure (BARO) Sensor — Lightning	303-14-18
Battery, Diagnosis and Testing	414-01-2
Battery, Removal and Installation	414-01-2
Battery and Cables	414-01-2
Battery Cables	414-01-4
Battery Disconnect	414-01-6
Battery Disconnect — Dual	414-01-7
Battery Tray	414-01-3
Bearing, General Procedures	308-00-23
Bearing, Removal and Installation	308-01-5
Bearing — Inspection	303-00-48
Bearings — Inspection	308-03-63
Belt — 4.2L	303-05-8
Belt — 4.6L, 5.4L With A/C	303-05-8
Belt — 4.6L, 5.4L Without A/C	303-05-9
Belt — Lightning	303-05-9
Belt Idler Pulley — 4.2L	303-05-12
Belt Idler Pulley — 4.6L, 5.4L	303-05-12
Belt Idler Pulley — Lightning	303-05-13
Belt Minder Deactivating/Activating	413-09-32
Separation	413-09-32
.....	413-09-33

Belt Tensioner — 4.2L	303-05-10
Belt Tensioner — 4.6L, 5.4L	303-05-10
Belt Tensioner — Lightning	303-05-11
Bleeding — — Components	206-00-17
Bleeding — System	206-00-24
Block Heater	303-03A-20
Blower Motor	412-02-5
Body	501-00-2
Body Closures	501-03-2
Body Sealer Types and Applications	501-00-2
Body System	501-00-3
Inspection and Verification — Body System	501-00-3
Symptom Chart — Body System	501-00-3
Brake Booster, Description and Operation	206-07-2
Hose and Check Valve	206-07-2
Brake Booster, Removal and Installation	206-07-2
Brake Caliper Anchor Plate	206-03-11
Brake Disc Machining	100-04-95
Brake Pedal — Adjustable	206-06-16
Brake Pedal Control Switch	206-06-24
Brake Pedal Motor	206-06-22
Brake Pedal Motor Cable	206-06-23
Brake Shift Interlock Actuator	307-05-14
Brake Shoe Adjustment	206-02-15
Brake Drums Removed	206-02-16
Brake Drums Installed	206-02-17
Brake System, Description and Operation	206-00-2
Brake Fluid	206-00-3
Brake System, Diagnosis and Testing	206-00-3
Symptom Chart	206-00-5
Pinpoint Tests	206-00-7
Component Tests	206-00-16
Bulb — Fog Lamp	417-01-67
Bulb — Headlamp	417-01-64
Bulb — Map Lamp	417-02-45
Bumper — Front	501-19-3
Bumper — Front, Arms	501-19-8
Bumper — Rear	501-19-6
Bumper Arms — Rear, Styleside	501-19-9
Bumper Bracket — Front	501-19-10
Bumper Cover — Lightning	501-19-2
Bumpers	501-19-2
Bushing — Carrier	205-03-19
Bushing — Control Arm	204-01B-25
Bushing — Cover	205-03-21
Bushing — Tube	205-03-23
Bushings, Bearing and Thrust Washer Locator, Description and Operation	307-01A-13
Bushings, Bearing and Thrust Washer Locator, Description and Operation	307-01B-12



BUY IT NOW!

Click Here To Order



Alphabetical Index

C

C-Pillar Trim Panel	501-05-7
Cable — Lead-In	415-02-2
Cable Adjustment — Shift Indicator.....	307-05-19
Cable and Bracket.....	307-05-15
Cable and Bracket Adjustment — 4.2L, 4.6L with 4R70W Transmission	307-05-19
Cable and Bracket Adjustment — 5.4L with 4R100 Transmission.....	307-05-21
Cable and Conduit — Front	206-05-8
Cable and Conduit — Rear.....	206-05-10
Calibration Adjustment	419-11-12
Caliper, Disassembly and Assembly	206-03-17
Caliper, Disassembly and Assembly	206-04-10
Caliper, Removal and Installation	206-03-8
Caliper, Removal and Installation	206-04-3
Camber and Caster Adjustment — 4x2	204-00-14
Camber and Caster Adjustment — 4x4	204-00-16
Camshaft, In-Vehicle Repair	303-01A-51
Camshaft, In-Vehicle Repair	303-01B-135
Camshaft — End Play Push Rod Engines	303-00-21
Camshaft — End Play, OHC Engines.....	303-00-22
Camshaft — Lobe Lift.....	303-00-23
Camshaft — Lobe Surface.....	303-00-23
Camshaft — Runout.....	303-00-24
Camshaft Journal — Clearance, Plastigage Method	303-00-21
Camshaft Journal — Clearance, Push Rod Engines, Micrometer Method.....	303-00-20
Camshaft Journal — Diameter	303-00-20
Camshaft Position (CMP) Sensor — 4.2L.....	303-14-4
Camshaft Position (CMP) Sensor — 4.6L and 5.4L	303-14-5
Canister — Evaporative Emissions	303-13-34
Canister Vent Solenoid Closing Procedure	303-13-41
Center Support	307-01A-247
Central Security Module.....	419-10-18
Inspection and Verification.....	419-10-18
Principles of Operation	419-10-18
Symptom Chart	419-10-19
Pinpoint Tests.....	419-10-20
Principles of Operation	419-10-16
Central Timer Module (CTM)/Generic Electronic Module (GEM).....	419-10-16
Inspection and Verification.....	419-10-16
Ignition Switch Positions.....	419-10-16
Pinpoint Tests.....	419-10-17
Symptom Chart	419-10-17
Air Cooler — Lightning.....	303-12-15
System Description and Operation	414-00-2
.....	414-00-2
.....	414-00-2
.....	414-00-3

Charging System, Diagnosis and Testing (Continued)

Symptom Chart	414-00-4
Pinpoint Tests	414-00-5
Component Tests	414-00-19
Child Safety Seat Tether Anchor	501-20A-17
Climate Control System, Description and Operation	412-00-3
System Airflow Description	412-00-7
Climate Control System, Diagnosis and Testing	412-00-11
Inspection and Verification.....	412-00-13
Symptom Chart	412-00-15
Pinpoint Tests	412-00-16
Component Tests	412-00-63
Clockspring, Removal and Installation	501-20B-101
Clockspring, Removal and Installation	211-04-9
Cluster Lens	413-01A-86
Clutch and Clutch Field Coil	412-03-16
Clutch Controls, Description and Operation	308-02-2
Clutch Controls, Diagnosis and Testing	308-02-3
Clutch Master Cylinder/Reservoir	308-02-4
Clutch Pedal.....	308-02-3
Clutch Pedal Position (CPP) Switch.....	303-14-35
Coalescer	310-01B-34
Coalescer Filter Element.....	310-01B-37
Coast Clutch Assembly	307-01A-233
Column.....	211-04-10
Communication Circuit Wiring Repair	418-00-43
Communications Network, Description and Operation	418-00-2
Communications Network, Diagnosis and Testing	418-00-2
Principles of Operation	418-00-2
Inspection and Verification.....	418-00-3
Pinpoint Tests.....	418-00-6
Compact Disc (CD) Changer — Regular Cab	415-01-5
Compact Disc (CD) Changer — Super Crew with Video System	415-01-7
Compact Disc (CD) Changer — SuperCab and Supercab Without Video.....	415-01-5
Compass Display.....	419-11-11
Compass Zone Adjustment.....	419-11-12
Compressor — 4.2L.....	412-03-10
Compressor — 4.6L and 5.4L.....	412-03-12
Compuvalve — Liquid Propane Gas, Removal and Installation	303-04D-27
Compuvalve — Natural Gas, Removal and Installation	303-04D-33
Condenser Core.....	412-03-39
Connecting Rod — Bearing Journal Clearance	303-00-35
Connecting Rod — Bend	303-00-34
Connecting Rod — Bushing Diameter.....	303-00-34
Connecting Rod — Cleaning	303-00-33
Connecting Rod — Large End Bore	303-00-33
Connecting Rod — Piston Pin Side Clearance.....	303-00-35



BUY IT NOW!

Click Here To Order



Alphabetical Index

Connecting Rod — Twist	303-00-34
Console — Floor	501-12-30
Console — Floor, Front	501-12-2
Console — Floor, Rear	501-12-2
Console — Overhead	501-12-2
Contaminated Refrigerant Handling	412-00-97
Control	206-05-5
Control Assembly	412-04-5
Control Components, Description and Operation	412-04-2
Control Components, Diagnosis and Testing	412-04-5
Cooler — Fluid	211-02-14
Cooler Bypass Valve	307-01A-169
Cooler Bypass Valve — 4R100 Transmission	307-02-12
Cooler Bypass Valve Assembly	307-01A-228
Cooling Fan — Blade, Clutch and Shroud	303-03A-30
Cooling System Draining, Filling and Bleeding	303-03A-37
Cowl — Grille	501-02-3
Crankshaft — Connecting Rod Journal Taper, Out of Round	303-00-27
Crankshaft — End Play	303-00-26
Crankshaft — Runout	303-00-27
Crankshaft Front Oil Seal, In-Vehicle Repair	303-01A-36
Crankshaft Front Oil Seal, In-Vehicle Repair	303-01B-92
Crankshaft Main Bearing Journal — Clearance	303-00-25
Crankshaft Main Bearing Journal — Diameter	303-00-24
Crankshaft Main Bearing Journal — Taper	303-00-25
Crankshaft Position (CKP) Sensor — 4.2L	303-14-9
Crankshaft Position (CKP) Sensor — 4.6L and 5.4L	303-14-10
Crankshaft Position (CKP) Sensor — Lightning	303-14-10
Crankshaft Pulley, In-Vehicle Repair	303-01A-33
Crankshaft Pulley, In-Vehicle Repair	303-01B-85
Crankshaft Pulley — Lightning	303-01B-87
Crankshaft Rear Oil Seal, In-Vehicle Repair	303-01A-81
Crankshaft Rear Oil Seal, In-Vehicle Repair	303-01B-216
Crankshaft Rear Oil Seal with Retainer Plate	303-01B-218
Cylinder Block — Core Plug Replacement	303-00-43
Cylinder Bore — Cleaning	303-00-43
Cylinder Bore — Out-of-Round	303-00-28
Cylinder Bore — Taper	303-00-28
Cylinder Head, Disassembly and Assembly of Subassemblies	303-01A-103
Cylinder Head, Disassembly and Assembly of Subassemblies	303-01B-253
Cylinder Head, In-Vehicle Repair	303-01A-61
Cylinder Head, In-Vehicle Repair	303-01B-149
Cylinder Head — Distortion	303-00-42
Cylinder Head Temperature (CHT) Sensor — 4.2L	303-14-33
Cylinder Head Temperature (CHT) Sensor — 4.6L and 5.4L	303-14-34

D

Daytime Running Lamps (DRL), Description and Operation	417-04-2
Daytime Running Lamps (DRL), Diagnosis and Testing	417-04-3
Inspection and Verification	417-04-3
Principles of Operation	417-04-3
Symptom Chart	417-04-3
Pinpoint Tests	417-04-4
Degas Bottle, Removal and Installation	303-03A-34
Degas Bottle, Removal and Installation	303-03B-9
Diagnosis by Symptom, Diagnosis and Testing	307-01A-101
Diagnosis by Symptom Index	307-01A-103
Diagnosis by Symptom, Diagnosis and Testing	307-01B-98
Diagnostic Flow Chart, Diagnosis and Testing	307-01A-28
Diagnostic Flow Chart, Diagnosis and Testing	307-01B-30
Diagnostic Instructions — Air Bag and Safety Belt Pretensioner Supplemental Restraint System (SRS)	501-20B-7
Inspection and Verification	501-20B-10
Symptom Chart	501-20B-10
Diagnostic Strategy, Diagnosis and Testing	307-01A-28
Diagnostic Strategy, Diagnosis and Testing	307-01B-29
Diagnostic Trouble Code Chart	419-10-2
Diagnostic Trouble Code Chart	419-10-2
Diagnostic Trouble Code Charts	307-01B-44
Diagnostics, Diagnosis and Testing	307-01A-34
On-Board Diagnostics with Diagnostic Tool	307-01A-35
Transmission Drive Cycle Test	307-01A-35
After On-Board Diagnostics	307-01A-36
Before Pinpoint Tests	307-01A-36
Diagnostic Trouble Code Charts	307-01A-36
Rotunda Transmission Tester	307-01A-45
Transmission Connector Layouts	307-01A-45
Pinpoint Tests	307-01A-47
Shift Solenoids Pre-Diagnosis	307-01A-47
Special Testing Procedures	307-01A-92
Leakage Inspection	307-01A-96
Transmission Fluid Cooler	307-01A-100
Diagnostics, Diagnosis and Testing	307-01B-37
Differential Bench Torque Test	205-02C-60
Differential Case, Disassembly and Assembly	205-03-57
Differential Case, In-Vehicle Repair	205-02A-30
Differential Case, In-Vehicle Repair	205-02B-29
Differential Case, In-Vehicle Repair	205-02C-34
Differential Case and Ring Gear — Conventional, Disassembly and Assembly	205-02A-44
Differential Case and Ring Gear — Conventional, Disassembly and Assembly	205-02B-43
Differential Case and Ring Gear — Conventional, Disassembly and Assembly	205-02C-46



BUY IT NOW!

Click Here To Order

PayPal

Discover
Card

DISCOVER
NEWUS

MasterCard

VISA

Alphabetical Index

Differential Case and Ring Gear — Traction-Lok, Disassembly and Assembly 205-02A-49

Differential Case and Ring Gear — Traction-Lok, Disassembly and Assembly 205-02C-51

Differential Case and Ring Gear — Traction-Lok® 205-02B-48

Differential Case Runout Check 205-03-69

Differential Housing Cover, In-Vehicle Repair 205-02A-18

Differential Housing Cover, In-Vehicle Repair 205-02B-15

Differential Housing Cover, In-Vehicle Repair 205-02C-20

Differential Pressure Feedback Exhaust Gas Recirculation (EGR) System — 4.2L and 4.6L 303-08-10

Differential Pressure Feedback Exhaust Gas Recirculation (EGR) System — 5.4L 303-08-11

Digital Transmission Range (TR) Sensor, In-Vehicle Repair 307-01A-171

Digital Transmission Range (TR) Sensor, In-Vehicle Repair 307-01B-149

Direct Clutch Assembly and Intermediate Brake Drum 307-01A-250

Disassembled Views, Description and Operation 307-01A-6

Disassembled Views, Description and Operation 307-01B-6

Disc, Removal and Installation 206-03-12

Disc, Removal and Installation 206-04-7

Disc and Pressure Plate 308-01-2

Disc Check 308-00-20

Door Ajar Switch 501-14-127

Door Latch Remote Control — Rear, F-150 501-14-122

Door Lock Actuator 501-14-126

Door Lock Actuator — Rear, SuperCrew 501-14-126

Door Lock Cylinder 501-14-121

Dowels — Flywheel 308-00-19

Dowels — Flywheel Housing to Block 308-00-19

Draining — Coalescer 310-00C-17

Draining — Coalescer/Filter 310-00B-3

Drive Cables and Guide Rails 501-17-20

Drive Pinion, In-Vehicle Repair 205-02A-20

Drive Pinion, In-Vehicle Repair 205-02B-17

Drive Pinion, In-Vehicle Repair 205-02C-22

Drive Pinion Flange, In-Vehicle Repair 205-02A-10

Drive Pinion Flange, In-Vehicle Repair 205-02B-10

Drive Pinion Flange, In-Vehicle Repair 205-02C-15

Drive Pinion Seal, In-Vehicle Repair 205-02A-16

Drive Pinion Seal, In-Vehicle Repair 205-02B-14

Drive Pinion Seal, In-Vehicle Repair 205-03-8

Driveline Angle Inspection 205-00-23

Driveline System, Description and Operation 205-00-2

Driveline System, Diagnosis and Testing 205-00-4

Inspection and Verification 205-00-5

Symptom Chart 205-00-13

Pinpoint Tests 205-00-14

Pinpoint Tests 205-00-17

Pinpoint Tests 205-01-2

Pinpoint Tests 205-01-5

Driveshaft — Front 205-01-5

Driveshaft — Rear, One-Piece 205-01-7

Driveshaft — Rear, Two-Piece 205-01-9

Driveshaft Center Bearing 205-01-11

Driveshaft Slip Yoke 205-01-29

Driveshaft Universal Joint — Double Cardan 205-01-24

Driveshaft Universal Joint — Single Cardan, Flange Yoke 205-01-20

Driveshaft Universal Joint — Single Cardan, Slip Yoke 205-01-16

Drum 206-02-3

Drum Brake, Description and Operation 206-02-2

Drum Brake, Diagnosis and Testing 206-02-3

Dual Converter Y-Pipe 309-00-10

Duct — Defrost Nozzles and Side Demister 412-01-7

Duct — Floor 412-01-9

E

Electronic Compass, Description and Operation 419-11-2

Electronic Compass, Diagnosis and Testing 419-11-2

Inspection and Verification 419-11-2

Pinpoint Tests 419-11-3

Symptom Chart 419-11-3

Electronic Engine Controls, Description and Operation 303-14-2

Electronic Engine Controls, Diagnosis and Testing 303-14-3

Electronic Engine Controls — Lightning 303-14-3

Electronic Leak Detection 412-00-81

Electronic Pressure Control (EPC) Solenoid 307-01B-140

End Play Check 307-01A-279

Engine, Assembly 303-01A-106

Engine, Assembly 303-01B-271

Engine, Description and Operation 303-00-4

Engine, Description and Operation 303-01A-2

Engine, Description and Operation 303-01B-3

Engine, Diagnosis and Testing 303-00-4

Inspection and Verification 303-00-5

Symptom Chart 303-00-6

Component Tests 303-00-9

Compression Test—Compression Gauge Check 303-00-10

Cylinder Leakage Detection 303-00-11

Oil Consumption Test 303-00-11

Intake Manifold Vacuum Test 303-00-13

Excessive Engine Oil Consumption 303-00-14

Valve Train Analysis—Engine Off—Valve Cover Removed 303-00-15

Valve Train Analysis—Engine Running 303-00-15

Engine, Diagnosis and Testing 303-01A-10

Engine, Diagnosis and Testing 303-01B-19

Engine, Disassembly 303-01A-89



BUY IT NOW!

Click Here To Order



Alphabetical Index

Frame Maintenance — Rivet Replacement	502-02-7	Fuel Injectors, Removal and Installation	303-04A-5
Frame Maintenance — Welding Precautions	502-02-8	Fuel Injectors, Removal and Installation	303-04B-6
Front Case Bushings	307-01A-224	Fuel Injectors, Removal and Installation	303-04C-11
Front Disc Brake, Description and Operation	206-03-2	Fuel Injectors — Liquid Propane Gas, Removal and Installation	303-04D-9
Front Disc Brake, Diagnosis and Testing	206-03-4	Fuel Injectors — Natural Gas, Removal and Installation	303-04D-12
Front Door Latch	501-14-98	Fuel Line Fittings — Push Connect	310-00A-8
Front Door Latch — SuperCrew	501-14-100	Fuel Pressure Regulator, Removal and Installation	303-04A-13
Front Door Trim Panel	501-05-3	Fuel Pressure Regulator, Removal and Installation	303-04B-32
Front Door Window Glass	501-11-59	Fuel Pressure Regulator — Natural Gas	310-01C-19
Front Door Window Regulator	501-11-66	Fuel Pressure Relief Valve	303-04A-14
Front Door Window Regulator Motor	501-11-63	Fuel System, Description and Operation	310-00A-2
Front Drive Axle	205-03-5	Fuel System, Description and Operation	310-00B-2
Front Drive Axle and Differential	205-03-2	Typical Vent Stack Installation	310-00B-2
Front Drive Halfshafts, Description and Operation	205-04-2	Coalescer/Filter	310-00B-2
Front Drive Halfshafts, Diagnosis and Testing	205-04-2	Fuel System, Diagnosis and Testing	310-00A-3
Front End Body Panels	501-02-2	Fuel System, Diagnosis and Testing	310-00B-3
Front Safety Belt Retractor — SuperCrew	501-20A-9	Fuel System — Bi-Fuel Systems	310-00C-4
Front Suspension, Description and Operation	204-01A-2	Fuel System — Lightning	310-00A-3
Front Suspension, Description and Operation	204-01B-2	Fuel System — Liquid Propane Gas	310-00C-2
Front Suspension, Diagnosis and Testing	204-01A-3	Fuel System — Natural Gas	310-00C-3
Front Suspension — 4x4	204-01B-3	Fuel System Leak Test	310-00B-28
Fuel Charging and Controls, Description and Operation	303-04A-2	Fuel System Service Precautions	303-04C-10
Fuel Charging and Controls, Description and Operation	303-04B-2	Fuel System Service Precautions — Liquid Propane Gas, Removal and Installation	303-04D-6
Fuel Charging and Controls, Description and Operation	303-04C-2	Fuel System Service Precautions — Natural Gas, Removal and Installation	303-04D-8
Fuel Pressure Regulator	303-04C-4	Fuel Tank and Lines, Description and Operation	310-01A-2
Fuel Injection Supply Manifold	303-04C-6	Fuel Tank and Lines, Description and Operation	310-01B-2
Fuel Shutoff Valve Solenoid	303-04C-6	Fuel Filler Valve	310-01B-3
Fuel Injectors	303-04C-6	Coalescer/Filter	310-01B-3
Fuel Pressure Relief Valve	303-04C-7	Fuel Tanks and Solenoid Valves	310-01B-3
Fuel Temperature Sensor	303-04C-7	Fuel Lines	310-01B-3
Fuel Charging Wiring	303-04C-7	Fuel Tank Straps	310-01B-3
Injection Pressure Sensor	303-04C-7	Fuel Tank and Lines, Description and Operation	310-01C-2
Fuel Charging and Controls, Description and Operation	303-04D-2	Fuel Tank and Lines, Diagnosis and Testing	310-01A-3
Fuel Charging and Controls, Diagnosis and Testing	303-04A-2	Fuel Tank and Lines, Diagnosis and Testing	310-01B-4
Fuel Charging and Controls, Diagnosis and Testing	303-04B-2	Symptom Chart	310-01B-4
Fuel Charging and Controls, Diagnosis and Testing	303-04C-9	Inspection and Verification	310-01B-4
Fuel Charging and Controls, Diagnosis and Testing	303-04D-5	Pinpoint Test	310-01B-4
Fuel Charging Wiring Harness, Removal and Installation	303-04A-6	Fuel Tank and Lines, Diagnosis and Testing	310-01C-2
Fuel Charging Wiring Harness, Removal and Installation	303-04B-7	Fuel Tank Draining	310-00A-4
Fuel Charging Wiring Harness — Lightning	303-04B-14	Fuel Tank Evacuation — Liquid Propane Gas	310-00C-10
Fuel Heater — Vaporizer, Removal and Installation	303-04D-38	Fuel Tank Evacuation — Natural Gas	310-00C-12
Fuel Injection Supply Manifold	303-04A-10	Fuel Tank Inspection, General Procedures	310-00B-29
Injection Supply Manifold — Fuel Injection	303-04B-19	Fuel Tank Inspection, General Procedures	310-00C-22
Injection Supply Manifold — Liquid Propane	303-04D-15	Fuel Tank Pressure Sensor, Removal and Installation	310-01B-48
Injection Supply Manifold — Natural Gas	303-04D-21	Fuel Tank Pressure Sensor, Removal and Installation	310-01C-22
		Fuel Tank Temperature Sensor	310-01B-47
		Fuel Tank Temperature Sensor — Natural Gas	310-01C-22



BUY IT NOW!

Click Here To Order



Alphabetical Index

G

Gauges and Warning Devices — GEM/CTM	413-09-2
Principles of Operation	413-09-3
Inspection and Verification	413-09-5
Symptom Chart	413-09-11
Gear	211-02-16
Gear — Power Steering	211-02-20
Geartrain	307-01B-17
Generator, Description and Operation	414-02-2
Generator, Diagnosis and Testing	414-02-2
Generator — 4.2L	414-02-2
Generator — 4.6L and 5.4L	414-02-3
Generator — Lightning	414-02-4
Window Glass — Rear Door—SuperCrew	501-11-2
Window Glass — Back	501-11-2
Glass, Frames and Mechanisms, Description and Operation	501-11-2
Windshield Glass	501-11-2
Window Glass — Rear Side	501-11-2
Glass, Frames and Mechanisms, Diagnosis and Testing	501-11-2
Inspection and Verification	501-11-3
Principles of Operation:	501-11-3
Pinpoint Tests	501-11-10
Symptom Chart	501-11-10
Glass, Frames and Mechanisms — Window Regulator Control	501-11-2
Glove Compartment	501-12-32
Grille Opening Panel Reinforcement	501-02-8

H

Halfshaft, Disassembly and Assembly	205-04-5
Halfshaft, Removal and Installation	205-04-3
Handles, Locks, Latches and Mechanisms	501-14-3
Keyless Entry	501-14-3
Autolock Enable/Disable — Using the Ignition Switch	501-14-4
Autolock Enable/Disable — Using the Keypad	501-14-4
Headlamp Adjustment — Photometric Aiming	417-01-73
Headlamp Adjustment — Screen Method Aiming	417-01-73
Headlamps	417-01-2
Inspection and Verification	417-01-2
Symptom Chart	417-01-3
Pinpoint Tests	417-01-4
Headliner	501-05-10
Horn	303-14-25
Horn, Description and Operation	413-06-2
Horn, Diagnosis and Testing	413-06-2
Symptom Chart	413-06-2
Inspection and Verification	413-06-2
Pinpoint Tests	413-06-3
Hose	211-02-13
Hydraulic Brake Actuation, Description and Operation	206-06-2
Hydraulic Brake Actuation, Diagnosis and Testing	206-06-3
Hydraulic Control Unit (HCU)	206-09B-48
Hydraulic Lash Adjusters	303-01B-132
Hydraulic Leak Check	206-00-28
Hydraulic System	307-01B-23
Hydraulic Tubes	308-02-10

I

Heated Oxygen Sensor (HO2S) — Front RH — Lightning	303-14-28
Heated Oxygen Sensor (HO2S) — Rear	303-14-27
Heated Oxygen Sensor (HO2S) — Rear LH — Lightning	303-14-31
Heated Oxygen Sensor (HO2S) — Rear RH — Lightning	303-14-29
Heater Core	412-02-7
Heater Hose — 4.2L	412-02-3
Heater Hose — 4.6L and 5.4L	412-02-4
Heater Hose Coupling	412-00-74
Heating/Defrosting, Description and Operation	412-02-2
Heating/Defrosting, Diagnosis and Testing	412-02-3
Height Adjuster — Shoulder Safety Belt, Regular Cab	501-20A-18
Hinge Adjustment — Front Door, Fore and Aft	501-03-3
Hinge Adjustment — Front Door, Horizontal and Vertical	501-03-2
Hinge Adjustment — Rear Door	501-03-4
Hinge Adjustment — Rear Door, SuperCrew	501-03-5
Hood Alignment — Horizontal	501-02-9
Hood Latch	501-14-97
Hood Latch Release Handle	501-14-111
Horn, Description and Operation	413-06-2
Horn, Diagnosis and Testing	413-06-2
Symptom Chart	413-06-2
Inspection and Verification	413-06-2
Pinpoint Tests	413-06-3
Hose	211-02-13
Hydraulic Brake Actuation, Description and Operation	206-06-2
Hydraulic Brake Actuation, Diagnosis and Testing	206-06-3
Hydraulic Control Unit (HCU)	206-09B-48
Hydraulic Lash Adjusters	303-01B-132
Hydraulic Leak Check	206-00-28
Hydraulic System	307-01B-23
Hydraulic Tubes	308-02-10
Identification Codes	100-01-2
Identification Tags, Description and Operation	307-01A-3
Identification Tags, Description and Operation	307-01B-3
Idle Air Control (IAC) Valve — 4.2L	303-14-14
Idle Air Control (IAC) Valve — 4.6L and 5.4L	303-14-15
Idle Air Control (IAC) Valve — Lightning	303-14-17
Idle Speed Adjustment	303-04C-30
Idle Speed Adjustment — Lightning	303-04B-34
Idler Arm and Bracket	211-03-17
Ignition Coil	303-07A-3
Ignition Coil-On-Plug	303-07B-3



BUY IT NOW!

Click Here To Order



Alphabetical Index

Ignition Switch 211-05-19

Ignition Switch Lock Cylinder — Functional Lock
Cylinder 211-04-4

Ignition Switch Lock Cylinder — Non-Functional
Lock Cylinder 211-04-5

Ignition System 303-07B-2

Indicator Switch — Shift Range Selector 308-07B-10

Input Shaft Bearing 308-03-34

Input Shell 307-01A-269

Inspection and Assembly Requirements —
Following an A/C Compressor Failure 412-00-94

Instrument Cluster, Description and Operation 413-01A-2

Instrument Cluster, Description and Operation 413-01C-2

Instrument Cluster, Diagnosis and Testing 413-01A-5
Principles of Operation 413-01A-5
Inspection and Verification 413-01A-7
Symptom Chart 413-01A-17
Pinpoint Tests 413-01A-19

Instrument Cluster, Diagnosis and Testing 413-01B-2
Principles of Operation 413-01B-2
Diagnostic Instructions 413-01B-3
Inspection and Verification 413-01B-5
Symptom Chart 413-01B-11
Pinpoint Tests 413-01B-12

Instrument Cluster, Diagnosis and Testing 413-01C-2
Principles of Operation 413-01C-2
Inspection and Verification 413-01C-3
Symptom Chart 413-01C-8
Pinpoint Tests 413-01C-9

Instrument Cluster, Removal and Installation 413-01A-83

Instrument Cluster — Natural Gas Vehicle 413-01B-2

Instrument Panel, Description and Operation 501-12-2

Instrument Panel, Removal and Installation 501-12-2

Instrument Panel — Cluster Panel 501-12-28

Instrument Panel — Steering Column Cover 501-12-27

Instrument Panel Illumination, Description and
Operation 413-00-2
Inspection and Verification 413-00-2
Principles of Operation 413-00-2

Instrument Panel Illumination, Diagnosis and Testing 413-00-2
Symptom Chart 413-00-2
Pinpoint Tests 413-00-3

Insulation 501-00-2

Intake Air Distribution and Filtering, Description and
Operation 303-12-2

Intake Air Distribution and Filtering, Diagnosis and
Testing 303-12-4

Intake Air Distribution and Filtering — Supercharger 303-12-5

Intake Air Distribution and Filtering —
Turbo Charge Air Cooler 303-12-4

Intake Air Temperature (IAT) Sensor — Intake
Manifold — Lightning 303-14-23

Intake Manifold — 4.6L 303-01B-19

Intake Manifold — 5.4L 303-01B-37

Intake Manifold — Lightning 303-01B-54

Intake Manifold — Spacer Assembly 303-01A-21

Intake Manifold Assembly — 4.6L 303-01B-267

Intake Manifold Assembly — 5.4L 303-01B-270

Interior Door Handle — Front 501-14-117

Interior Door Handle — Rear, F-150 501-14-119

Interior Door Handle — Rear, SuperCrew 501-14-118

Interior Lighting 417-02-2

Interior Lighting — GEM/CTM 417-02-2
Principles of Operation 417-02-2
Inspection and Verification 417-02-3
GEM Diagnostic Trouble Code (DTC) Index 417-02-4
Symptom Chart 417-02-4
Pinpoint Tests 417-02-5

Interior Trim 501-05-2

Intermediate One-Way Clutch 307-01B-201

Intermediate Servo 307-01A-175

Intermediate/Overdrive Cylinder Assembly 307-01A-243

Intake Air Temperature (IAT) Sensor — Intake
Manifold — Lightning 303-14-23

Intake Manifold — 4.6L 303-01B-19

Intake Manifold — 5.4L 303-01B-37

Intake Manifold — Lightning 303-01B-54

Intake Manifold — Spacer Assembly 303-01A-21

Intake Manifold Assembly — 4.6L 303-01B-267

Intake Manifold Assembly — 5.4L 303-01B-270

Interior Door Handle — Front 501-14-117

Interior Door Handle — Rear, F-150 501-14-119

Interior Door Handle — Rear, SuperCrew 501-14-118

Interior Lighting 417-02-2

Interior Lighting — GEM/CTM 417-02-2
Principles of Operation 417-02-2
Inspection and Verification 417-02-3
GEM Diagnostic Trouble Code (DTC) Index 417-02-4
Symptom Chart 417-02-4
Pinpoint Tests 417-02-5

Interior Trim 501-05-2

Intermediate One-Way Clutch 307-01B-201

Intermediate Servo 307-01A-175

Intermediate/Overdrive Cylinder Assembly 307-01A-243

J

Jacking 100-02-2

K

Key Programming — Additional Key With One
Programmed Key 419-01-38

Key Programming — Enable/Disable Spare Key
Programming 419-01-37

Key Programming — Erase All Key Codes and
Program Two Keys 419-01-36

Key Programming — Program a Key Using Two
Programmed Keys 419-01-34

Key Release Button 211-05-21

Keyless Entry Keypad 501-14-127

Keyless Entry Keypad Code Programming 501-14-128

Knock Sensor (KS) — 4.2L 303-14-32

Knock Sensor (KS) — 4.6L and 5.4L 303-14-32

Knuckle — Front Wheel 204-01B-19

L

Lamp Assembly — Fog Lamp 417-01-69

100% SATISFACTION GUARANTEED

BUY IT NOW!

Click Here To Order

Alphabetical Index

- Lamp Assembly — Map 417-02-44
 Lamp Assembly — Signal Mirrors 417-01-71
 Lamp Switch — Brake Pedal Position (BPP) 417-01-72
 Lamp Switch — Headlamp 417-01-71
 Leak Test — Bi-Fuel System 310-00C-19
 Leak Test — Evaporative Emission System 303-13-41
 Leakage Inspection 307-01B-94
 Lifting 100-02-3
 Lifting Points — Twin Post Hoist 100-02-3
 Line — 4.2L 412-03-47
 Line — 4.6L and 5.4L 412-03-48
 Lines — Front High-Pressure Fuel 310-01B-41
 Lines — Low-Pressure Fuel 310-01B-43
 Lines — Rear High-Pressure Fuel 310-01B-39
 Locks, Latches and Entry Systems — Module
 Controlled Vehicles Built After 10/2/2000 501-14-60
 Principles of Operation 501-14-60
 Inspection and Verification 501-14-61
 Symptom Chart 501-14-62
 Pinpoint Tests 501-14-63
 Locks, Latches and Entry Systems — Module
 Controlled Vehicles Built Before 10/2/2000 501-14-16
 Inspection and Verification 501-14-16
 Symptom Chart 501-14-17
 Pinpoint Tests 501-14-18
 Locks, Latches and Entry Systems — Non Module
 Controlled 501-14-5
 Inspection and Verification 501-14-5
 Symptom Chart 501-14-5
 Pinpoint Tests 501-14-6
 Low One-Way Clutch Assembly 307-01A-271
 Lower Intake Manifold 303-01A-14
 Manifold and Tube Assembly — 4.6L and 5.4L 412-03-44
 Manifold Gauge Set Connection 412-00-79
 Manual Control Lever Shaft and Seal, In-Vehicle
 Repair 307-01A-164
 Manual Control Lever Shaft and Seal, In-Vehicle
 Repair 307-01B-143
 Manual Transmission, Description and Operation 308-03-2
 Manual Transmission, Diagnosis and Testing 308-03-3
 Manual Transmission and Clutch, Description and
 Operation 308-00-2
 Manual Transmission and Clutch, Diagnosis and
 Testing 308-00-3
 Symptom Chart 308-00-3
 Mass Air Flow (MAF) Sensor 303-14-19
 Mass Air Flow (MAF) Sensor — Lightning 303-14-21
 Master Cylinder, Disassembly and Assembly 206-06-29
 Master Cylinder, Removal and Installation 206-06-25
 Meshload Adjustment 211-00-17
 Mirror — Cover, Exterior Rear View Mirror 501-09-17
 Mirror — Glass, Exterior Rear View Mirror 501-09-19
 Mirror — Inside Rear View, Bracket 501-09-23
 Mirror — Interior Mirror 501-09-22
 Module — Anti-Lock Brake Control 206-09A-49
 Module — Central Security Module (CSM) 419-10-27
 Module — Driver Air Bag 501-20B-86
 Module — Generic Electronic (GEM)/Central Timer
 (CTM) 419-10-25
 Module — Natural Gas Vehicle (NGV) 413-01B-55
 Module — Passenger Air Bag 501-20B-94
 Module — Passive Anti-Theft Transceiver 419-01-33
 Module — Restraints Control 501-20B-81
 Module Configuration 418-01-2
 Principles of Operation 418-01-2
 Inspection and Verification 418-01-3
 Module Controlled Functions 419-10-2
 Motor 501-16-64
 Mounting Arm and Pivot Shaft — Windshield Wiper 501-16-61
 Multifunction Switch 211-05-17
 Diagnostic Theory 100-04-2
 Acceptable Noise, Vibration and Harshness 100-04-2
 Glossary of Terms 100-04-2

M

- Main Components and Functions, Description and
 Operation 307-01A-16
 Torque Converter 307-01A-16
 Geartrain 307-01A-17
 Main Components and Functions, Description and
 Operation 307-01B-16
 Main Control — Valve Body 307-01B-130
 Main Control — Valve Body, Accumulator Body,
 Solenoid Body 307-01A-144
 Main Control Valve Body 307-01B-187
 Main Control Valve Body — Accumulator Body
 Check 307-01A-210
 in Control Valve Body — Disassembly and
 307-01A-203
 307-01A-209
 412-03-41

N

- Noise, Vibration and Harshness (NVH), Description
 and Operation 100-04-2
 Tools and Techniques 100-04-7
 Noise, Vibration and Harshness (NVH), Diagnosis
 and Testing 100-04-11
 1: Customer Interview 100-04-15
 2: Pre-Drive Check 100-04-15



BUY IT NOW!

Click Here To Order



Alphabetical Index

Noise, Vibration and Harshness (NVH), Diagnosis and Testing (Continued)

3: Preparing for the Road Test	100-04-15
4: Verify the Customer Concern	100-04-15
5: Road Test	100-04-16
6: Check OASIS/TSBs/Repair History	100-04-18
NVH Condition and Symptom Categories	100-04-18
7: Diagnostic Procedure	100-04-18
Symptom Charts	100-04-20
Pinpoint Tests	100-04-57
Component Tests	100-04-90
Safety Belt Extension Assembly	501-20A-2
Warning System — Driver Safety Belt	501-20A-2

O

Occupant Restraint System, Description and Operation	501-20A-2
Dual Locking Mode Retractors	501-20A-2
Occupant Restraint System, Diagnosis and Testing	501-20A-3
Inspection and Verification	501-20A-3
Component Test	501-20A-4
Symptom Chart	501-20A-4
Oil Cooler	303-01B-155
Oil Filter Adapter — 4x2	303-01B-157
Oil Filter Adapter — 4x4	303-01B-161
Oil Level Indicator and Tube, In-Vehicle Repair	303-01A-70
Oil Level Indicator and Tube, In-Vehicle Repair	303-01B-165
Oil Pan — 4x2	303-01A-70
Oil Pan — 4x2, 4.6L	303-01B-167
Oil Pan — 4x2, 5.4L	303-01B-186
Oil Pan — 4x4, In-Vehicle Repair	303-01A-73
Oil Pan — 4x4, In-Vehicle Repair	303-01B-202
Oil Pump, In-Vehicle Repair	303-01A-77
Oil Pump, In-Vehicle Repair	303-01B-206
Oil Pump Screen and Pickup Tube, In-Vehicle Repair	303-01A-79
Oil Pump Screen and Pickup Tube, In-Vehicle Repair	303-01B-209
Output Shaft	308-03-35
Output Shaft — Check	307-01A-266
Output Shaft and Direct Clutch Cylinder	307-01B-222
Output Shaft Speed Sensor	308-07B-13
Output State Control (OSC) Mode	307-01B-39
Overdrive Ring Gear and Center Shaft Assembly	307-01A-237
Overdrive Servo	307-01B-156

Panel	501-04-2
Park System	307-01A-176
Parking Brake, Description and Operation	206-05-2
Rear Disc Brakes	206-05-3
Parking Brake, Diagnosis and Testing	206-05-4
Symptom Chart	206-05-4
Inspection and Verification	206-05-4
Parking, Rear and License Lamps	417-01-31
Inspection and Verification	417-01-31
Pinpoint Tests	417-01-32
Symptom Chart	417-01-32
Passenger Air Bag Deactivation (PAD) Switch	501-20B-115
Pedal and Bracket — Adjustable	206-06-9
Pedal and Bracket — Fixed, Automatic Transmission	206-06-3
Pedal and Bracket — Fixed, Manual Transmission	206-06-6
Pickup Bed, Description and Operation	501-04-2
Pickup Bed, Removal and Installation	501-04-6
Pinion Seal	205-02C-19
Pinpoint Tests — Air Bag and Safety Belt Pretensioner Supplemental Restraint System (SRS)	501-20B-11
Pinpoint Tests — OSC Equipped Vehicles	307-01B-54
Piston	303-01A-104
Piston — Diameter	303-00-30
Piston — Inspection	303-00-28
Piston — Pin Connecting Rod, Floating Pin	303-01B-264
Piston — Pin Connecting Rod, Press Fit	303-01B-262
Piston — Pin Diameter	303-00-33
Piston — Pin to Bore Diameter	303-00-29
Piston — Ring End Gap	303-00-31
Piston — Ring-to-Groove Clearance	303-00-32
Piston — Selection	303-00-31
Piston — to Cylinder Bore Clearance	303-00-30
Pivot Arm	501-16-61
Planetary Gear Support Assembly and Planetary One-Way Clutch	307-01B-219
Plenum Chamber	412-01-11
Power Brake System	206-07-2
Power Steering, Description and Operation	211-02-2
Steering Gear	211-02-2
Power Steering Pump	211-02-2
Pump Identification	211-02-4
Steering Gear Identification	211-02-4
Power Steering, Diagnosis and Testing	211-02-4
Powertrain Control Module (PCM)	303-14-11
Powertrain/Drivetrain Mount Neutralizing	100-04-97
Preliminary Inspection, Diagnosis and Testing	307-01A-29
Verification of Condition	307-01A-29
Know/Understand the Concern	307-01A-29
Visual Inspection	307-01A-33
Preliminary Inspection, Diagnosis and Testing	307-01B-30
Know and Understand the Concern	307-01B-31

P

.....	206-03-4
.....	206-04-5



BUY IT NOW!

Click Here To Order



Alphabetical Index

Preliminary Inspection, Diagnosis and Testing (Continued)

Verification of Condition 307-01B-31

Pressure Cutoff Switch 412-03-37

Pressure Plate Adjustment 308-00-23

Pressure Plate Check 308-00-21

Pressure Regulator — Fuel 303-04C-25

Pressure Relief 310-00A-3

Pressure Relief — Fuel Line Venting 310-00B-7

Pressure Relief — Fuel Rail Tuning Adjustment 310-00C-29

Pressure Relief — Fuel Tank Venting 310-00B-11

Pressure Relief — Liquid Propane Gas Bi-Fuel System 310-00C-5

Pressure Relief — Natural Gas Bi-Fuel System 310-00C-8

Pressure Relief Valve 303-04B-33

Pressure Relief Valve — 4.2L 412-03-38

Pressure Relief Valve — 4.6L and 5.4L 412-03-38

Pressure Relief Valve — Fuel 303-04C-29

Pressure Sensor — Fuel Tank 303-13-39

Programming 419-02-4

 Training a Garage Door Opener Equipped With “Rolling Codes” 419-02-5

 Erasing Channels 419-02-6

Pulley — Pump, In-Vehicle, Lightning Vehicles 211-02-12

Pulley — Pump, On-Bench 211-02-11

Pump, Removal and Installation 310-01A-14

Pump, Removal and Installation 211-02-7

Pump — Lightning 310-01A-15

Pump and Intermediate Clutch Piston 307-01B-195

Pump Assembly 307-01A-211

Purging 211-00-12

Push Rod Adjustment 206-07-4

Push Rods — Cleaning 303-00-19

Push Rods — Inspection 303-00-19

R

Radiator, Removal and Installation 303-03A-28

Radiator, Removal and Installation 303-03B-8

Radiator Grille 501-08-5

Radiator Grille — Bumper Cover 501-08-7

Range Selection, Description and Operation 307-01A-3

Range Selection, Description and Operation 307-01B-4

Rear Case Bushings 307-01A-226

Rear Disc Brake, Description and Operation 206-04-2

Rear Disc Brake, Diagnosis and Testing 206-04-2

Rear Door Latch — Lower 501-14-103

Rear Door Latch — SuperCrew 501-14-106

Rear Door Window Regulator — SuperCrew 501-11-68

Rear Door Window Regulator Motor — SuperCrew 501-11-64

Rear Drive Axle and Differential, Description and Operation 205-02A-2

Rear Drive Axle and Differential, Description and Operation 205-02B-2

Rear Drive Axle and Differential, Description and Operation 205-02C-2

Rear Drive Axle and Differential, Diagnosis and Testing 205-02A-4

Rear Drive Axle and Differential, Diagnosis and Testing 205-02B-5

Rear Drive Axle and Differential, Diagnosis and Testing 205-02C-4

Rear Footwell Duct 412-01-10

Rear Safety Belt Retractor — Center, SuperCrew 501-20A-12

Rear Safety Belt Retractor — Outboard, SuperCrew 501-20A-12

Rear Seat Backrest — SuperCrew 40 Percent, Disassembly and Assembly 501-10-70

Rear Seat Backrest — SuperCrew 40 Percent, Removal and Installation 501-10-27

Rear Seat Backrest — SuperCrew 60 Percent, Disassembly and Assembly 501-10-70

Rear Seat Backrest — SuperCrew 60 Percent, Removal and Installation 501-10-28

Rear Seat Backrest Latch — SuperCrew 501-10-31

Rear Seat Cushion — SuperCrew 40 Percent, Disassembly and Assembly 501-10-65

Rear Seat Cushion — SuperCrew 40 Percent, Removal and Installation 501-10-25

Rear Seat Cushion — SuperCrew 60 Percent, Disassembly and Assembly 501-10-66

Rear Seat Cushion — SuperCrew 60 Percent, Removal and Installation 501-10-26

Rear Suspension, Description and Operation 204-02-2

 Anti-Windup Bar 204-02-4

 Suspension Fasteners 204-02-4

 Shock Absorbers 204-02-4

 Rear Spring 204-02-4

 Rear Axle Bumpers 204-02-4

Rear Suspension, Diagnosis and Testing 204-02-5

Rear View Mirrors, Description and Operation 501-09-2

Rear View Mirrors, Diagnosis and Testing 501-09-2

 Inspection and Verification 501-09-2

 Pinpoint Tests 501-09-3

 Symptom Chart 501-09-3

 Component Test 501-09-15

Rear Wheel Bearing and Axle Shaft Oil Seal, In-Vehicle Repair 205-02A-8

Rear Wheel Bearing and Axle Shaft Oil Seal, In-Vehicle Repair 205-02B-8

Rear Wheel Bearing and Axle Shaft Oil Seal — Disc Brake 205-02C-11



BUY IT NOW!

Click Here To Order



Alphabetical Index

Rear Wheel Bearing and Axle Shaft Oil Seal —
 Drum Brake 205-02C-13
 Refrigerant Identification Testing 412-00-95
 Refrigerant Oil Adding 412-00-92
 Refrigerant System Filtering Following Air
 Conditioning (A/C) Component Installation 412-00-90
 Refrigerant System Tests 412-00-76
 Register — Center 412-01-5
 Register — LH 412-01-4
 Register — RH 412-01-6
 Remote Anti-Theft Personality (RAP) Module,
 Diagnosis and Testing 419-10-22
 Inspection and Verification 419-10-22
 Principles of Operation 419-10-22
 Pinpoint Tests 419-10-23
 Symptom Chart 419-10-23
 Remote Anti-Theft Personality (RAP) Module,
 Removal and Installation 419-10-28
 Remote Transmitter Programming 501-14-128
 Replacement of the Weld Nut and Reinforcement 501-20A-33
 Reservoir 206-06-27
 Reservoir — 4.2L Engine 211-02-4
 Reservoir — 4.6L and 5.4L Engines 211-02-6
 Retractor — Rear, SuperCab 501-20A-5
 Retractor — Regular Cab 501-20A-8
 Retractor — SuperCab, Front 501-20A-6
 Reverse Clutch 307-01B-202
 Reverse Clutch Piston 307-01A-273
 Reverse Idler Gear 308-03-41
 Reverse Planet Assembly 307-01A-270
 Reverse Servo Assembly 307-01B-152
 Reverse Sun Gear 307-01B-220
 Reversing Lamps 417-01-44
 Symptom Chart 417-01-44
 Inspection and Verification 417-01-44
 Pinpoint Tests 417-01-45
 Ride Height 204-01B-26
 Ring Gear 308-01-7
 Road Testing Vehicle 307-01B-32
 Rocker Arms — Cleaning 303-00-18
 Rocker Arms — Inspection 303-00-19
 Roller Follower — Inspection 303-00-36
 Roller Followers 303-01B-133
 Roof Opening Panel, Description and Operation 501-17-2
 Roof Opening Panel, Diagnosis and Testing 501-17-2
 Inspection and Verification 501-17-2
 Symptom Chart 501-17-2
 Pinpoint Tests 501-17-4
 Roof Opening Panel, Removal and Installation 501-17-16
 Roof Opening Panel Alignment — Height 501-17-22
 Roof Opening Panel, Removal and Installation 501-17-21

Roof Opening Panel Frame 501-17-18
 Roof Opening Panel Module 501-17-19
 Roof Opening Panel Motor 501-17-16

S

Safety Belt — 60/40 Split and Front Bench Seat,
 Center Passenger 501-20A-16
 Safety Belt — Rear, SuperCab 501-20A-17
 Safety Belt Buckle — 40 Percent Portion of 60/40
 Split Bench 501-20A-29
 Safety Belt Buckle — 60 Percent Portion of 60/40
 Split Bench 501-20A-28
 Safety Belt Buckle — Bucket Seats 501-20A-25
 Safety Belt Buckle — Full Bench Seat 501-20A-27
 Safety Belt Buckle — Rear, Left Hand Passenger,
 SuperCrew 501-20A-32
 Safety Belt Buckle — Rear, Right Hand and Center
 Passenger SuperCrew 501-20A-32
 Safety Belt Buckle — Rear, SuperCab 501-20A-30
 Safety Belt Cleaning 501-20A-33
 Safety Belt Procedure After a Collision 501-20A-36
 Safety Belt Shoulder Height Adjuster — Front,
 SuperCrew 501-20A-19
 Safety Belt Shoulder Height Adjuster — Rear,
 SuperCrew 501-20A-23
 Safety Belt Shoulder Height Adjuster With Stripped
 Weld Nuts 501-20A-34
 Safety Belt Tongue Rotated on Belt 501-20A-36
 Safety Precautions 204-04-2
 Seal — Oil 308-07B-5
 Seals, Rings and Gasket Locator, Description and
 Operation 307-01A-14
 Seals, Rings and Gasket Locator, Description and
 Operation 307-01B-14
 Seat — 40 Percent Front Bench, Disassembly and
 Assembly 501-10-43
 Seat — 40 Percent Front Bench, Removal and
 Installation 501-10-16
 Seat — 60 Percent Front Bench, Disassembly and
 Assembly 501-10-45
 Seat — 60 Percent Front Bench, Removal and
 Installation 501-10-16
 Seat — Back, 40 Percent Front Bench 501-10-43
 Seat — Back, 60 Percent Front Bench 501-10-52
 Seat — Back, Captain's Chair 501-10-37
 Seat — Back, Front Bench 501-10-53
 Seat — Captain's Chair, Disassembly and
 Assembly 501-10-33
 Seat — Captain's Chair, Removal and Installation 501-10-14
 Seat — Cushion, 40 Percent Front Seat Bench 501-10-43

100% SATISFACTION GUARANTEED

BUY IT NOW!

Click Here To Order

PayPal American Express Discover MasterCard VISA

Alphabetical Index

Seat — Cushion, 40 Percent Rear	501-10-60	Spark Plug, Removal and Installation	303-07B-4
Seat — Cushion, 60 Percent Bench	501-10-51	Spark Plug — Inspection	303-00-45
Seat — Cushion, 60 Percent Rear	501-10-63	Spark Plug Wire	303-07A-4
Seat — Cushion, Captain's Chair	501-10-40	Speakers	415-03-2
Seat — Cushion, Front Bench	501-10-56	Speakers — Door Mounted	415-03-2
Seat — Front Bench	501-10-52	Special Testing Procedures	307-01B-88
Seat — Full Bench	501-10-19	SPECIFICATIONS	
Seat — Rear Cushion, Disassembly and Assembly	501-10-58	Body System — General Information	501-00-5
Seat — Rear Cushion, Removal and Installation	501-10-20	Front End Body Panels	501-02-11
Seat — SuperCrew Rear 40 Percent	501-10-17	Body Closures	501-03-5
Seat — SuperCrew Rear 60 Percent	501-10-18	Pickup Bed and Platform Body	501-04-12
Seat — Track, Manual, Disassembly and Assembly	501-10-43	Interior Trim and Ornamentation	501-05-14
Seat — Track, Manual, Removal and Installation	501-10-21	Exterior Trim and Ornamentation	501-08-8
Seat — Track, Power	501-10-23	Rear View Mirrors	501-09-25
Seat Backrest — Rear Seat	501-10-13	Seating	501-10-71
Seat Latch — SuperCrew Rear Seat	501-10-32	Glass, Frames and Mechanisms	501-11-78
Seats, Description and Operation	501-10-3	Instrument Panel and Console	501-12-34
Seats, Diagnosis and Testing	501-10-3	Handles, Locks, Latches and Entry Systems	501-14-129
Inspection and Verification	501-10-3	Wipers and Washers	501-16-69
Symptom Chart	501-10-3	Roof Opening Panel	501-17-23
Pinpoint Tests	501-10-4	Bumpers	501-19-10
Sector Shaft Arm — 4x2	211-03-10	Occupant Restraints — Active	501-20A-37
Sector Shaft Arm — 4x4	211-03-12	Occupant Restraints — Passive — Supplemental	
Sector Shaft Arm Drag Link	211-03-8	Air Bag System	501-20B-136
Security Access — Procedure	419-01-39	Full Frame and Body Mounting	502-02-9
Selector Lever	307-05-17	Engine System — General Information	303-00-48
Sender Unit — 4.2L	303-03A-35	Engine — 4.2L	303-01A-134
Sensor — Front, 4x2	206-09B-52	Engine — 4.6L and 5.4L	303-01B-323
Sensor — Front, 4x4	206-09B-53	Engine Cooling	303-03A-41
Sensor — Fuel Tank Pressure	413-01B-57	Supercharger Cooling	303-03B-13
Sensor — Rear, Removal and Installation	206-09A-49	Fuel Charging and Controls — 4.2L	303-04A-15
Sensor — Rear, Removal and Installation	206-09B-51	Fuel Charging and Controls — 4.6L (2V) and 5.4L	
Sensor — Tank Temperature	413-01B-58	(2V)	303-04B-34
Sensor Indicator	206-09A-50	Fuel Charging and Controls — Natural Gas	
Sensor Indicator — Front, 4x2	206-09B-54	Vehicle	303-04C-30
Shaft Seal	412-03-20	Fuel Charging and Controls — Bi-Fuel Vehicles	303-04D-42
Shield, Removal and Installation	206-03-15	Accessory Drive	303-05-13
Shield, Removal and Installation	206-04-9	Starting System	303-06-32
Shift Control Housing	308-03-27	Engine Ignition — 4.2L	303-07A-6
Shift Lever	308-07B-7	Engine Ignition — 4.6L (2V) and 5.4L (2V)	303-07B-4
Shift Lever and Boot	308-03-10	Engine Emission Control	303-08-12
Shift Patterns, Description and Operation	307-01A-4	Intake Air Distribution and Filtering	303-12-25
Shift Patterns, Description and Operation	307-01B-5	Evaporative Emissions	303-13-45
Shift Point Road Test	307-01B-32	Electronic Engine Controls	303-14-38
Shift Switch — 4WD Indicator	308-07B-6	Suspension System — General Information	204-00-19
Shoes	206-02-7	Front Suspension — 4x2	204-01A-24
Shoes — Rear Disc Brakes	206-05-12	Front Suspension — 4x4	204-01B-28
Slave Cylinder	308-02-9	Rear Suspension	204-02-10
Solenoid — Canister Vent	303-13-40	Wheels and Tires	204-04-7
Solenoid Valve — Fuel Tank	310-01B-29	Driveline System — General Information	205-00-26
.....	310-01C-10	Driveshaft	205-01-32
.....	310-01B-31	Rear Drive Axle/Differential — Ford 8.8-Inch	
.....	303-07A-5	Ring Gear	205-02A-58



BUY IT NOW!

Click Here To Order



Alphabetical Index

SPECIFICATIONS (Continued)

Rear Drive Axle/Differential — Ford 9.75-Inch
 Ring Gear 205-02B-58

Rear Drive Axle/Differential — Ford 10.25-Inch
 Ring Gear 205-02C-61

Front Drive Axle/Differential — Ford 8.8-Inch
 Ring Gear 205-03-74

Front Drive Halfshafts 205-04-13

Brake System — General Information 206-00-29

Drum Brake 206-02-17

Front Disc Brake 206-03-19

Rear Disc Brake 206-04-13

Parking Brake and Actuation 206-05-18

Hydraulic Brake Actuation 206-06-33

Power Brake Actuation 206-07-5

Anti-Lock Control — Rear 206-09A-50

Anti-Lock Control — 4-Wheel 206-09B-55

Automatic Transmission — 4R100 307-01A-322

Automatic Transmission — 4R70W 307-01B-270

Transaxle/Transmission Cooling 307-02-27

Automatic Transaxle/Transmission External
 Controls 307-05-23

Manual Transaxle/Transmission and Clutch —
 General Information 308-00-24

Clutch 308-01-8

Clutch Controls 308-02-12

Manual Transaxle/Transmission 308-03-65

Transfer Case 308-07B-51

Exhaust System — General Information 309-00-15

Fuel System — General Information 310-00A-14

Fuel System — General Information — Natural
 Gas 310-00B-34

Fuel System — General Information — Bi-Fuel
 Vehicles 310-00C-34

Fuel Tank and Lines 310-01A-19

Fuel Tank and Lines — Natural Gas 310-01B-49

Fuel Tank and Lines — Bi-Fuel Vehicles 310-01C-23

Acceleration Control 310-02-13

Vehicle Speed Control 310-03-36

Steering System — General Information 211-00-21

Power Steering 211-02-35

Steering Linkage 211-03-18

Steering Column 211-04-56

Steering Column Switches 211-05-22

Climate Control System — General Information 412-00-99

Air Distribution and Filtering 412-01-13

Heating and Ventilation 412-02-9

Air Conditioning 412-03-51

Components 412-04-14

..... 413-01A-87

..... 413-01B-59

..... 413-06-12

..... 414-01-8

SPECIFICATIONS (Continued)

Generator and Regulator 414-02-7

Audio Unit 415-01-7

Antenna 415-02-3

Exterior Lighting 417-01-75

Daytime Running Lamps 417-04-10

Module Communications Network 418-00-45

Anti-Theft — PATS 419-01-40

Multifunction Electronic Control Modules 419-10-29

Speed Control Cable 310-03-32

Speed Control Servo 310-03-33

Spindle 204-01A-15

Spring 204-02-8

Spring — Coil 204-01A-20

Spring Lock Coupling 412-00-67

Spring Lock Couplings 310-00B-4

Spring Lock Couplings — Spring Lock 310-00A-5

Sprockets 303-00-18

Starter Drive and Flywheel Ring Gear Inspection 303-06-31

Starter Motor 303-06-27

Starting System, Description and Operation 303-06-2

Starting System, Diagnosis and Testing 303-06-3

Inspection and Verification 303-06-3

Symptom Chart 303-06-4

Pinpoint Tests 303-06-5

Steering Column, Description and Operation 211-04-2

Steering Column, Diagnosis and Testing 211-04-4

Steering Column — Automatic Transmission 211-04-29

Steering Column — Manual Transmission 211-04-14

Steering Column Shaft 211-04-13

Steering Column Switches, Description and
 Operation 211-05-2

Steering Column Switches, Diagnosis and Testing 211-05-3

Inspection and Verification 211-05-3

Symptom Chart 211-05-10

Pinpoint Tests 211-05-11

Component Test 211-05-17

Steering Linkage, Description and Operation 211-03-2

Steering Linkage, Diagnosis and Testing 211-03-2

Steering System, Description and Operation 211-00-2

Inspection and Verification 211-00-3

Steering System, Diagnosis and Testing 211-00-3

Symptom Chart 211-00-5

Component Tests 211-00-7

Stoplamps 417-01-22

Symptom Chart 417-01-22

Inspection and Verification 417-01-22

Pinpoint Tests 417-01-23

Suction Accumulator — 4.2L 412-03-29

Suction Accumulator — 4.6L and 5.4L 412-03-32

Supercharger Bypass Vacuum Solenoid — Actuator
 — Lightning 303-14-37

100% SATISFACTORY GUARANTEED

BUY IT NOW!

Click Here To Order

PayPal American Express Discover MasterCard VISA

Alphabetical Index

Supercharger Bypass Vacuum Solenoid — Lightning	303-14-36	Throttle Body, Removal and Installation.....	303-04A-3
Supercharger Cooling, Description and Operation	303-03B-2	Throttle Body, Removal and Installation.....	303-04B-3
Supercharger Cooling, Diagnosis and Testing	303-03B-2	Throttle Body — Lightning	303-04B-4
Inspection and Verification.....	303-03B-3	Throttle Position (TP) Sensor — 4.2L.....	303-14-12
Pinpoint Tests.....	303-03B-4	Throttle Position (TP) Sensor — 4.6L and 5.4L.....	303-14-13
Symptom Chart	303-03B-4	Throttle Position (TP) Sensor — Lightning.....	303-14-14
Component Tests	303-03B-6	Tie Rod End — — Adjusting Sleeve.....	211-03-7
Supercharger Cooling System Draining, Filling and Bleeding	303-03B-10	Tie Rod End — — Inner	211-03-3
Supercharger Cooling System Flushing.....	303-03B-12	Tie Rod End — — Outer	211-03-5
Supplemental Restraint System (SRS) Deactivation and Reactivation, General Procedures	501-20B-124	Timing Chain — Tensioner.....	303-01A-53
Supplemental Restraint System (SRS) Deactivation and Reactivation, General Procedures	211-04-49	Timing Drive Components — Romeo Engine	303-01B-117
Supply Manifold — Fuel Injection	303-04C-16	Timing Drive Components — Windsor Engine	303-01B-105
Support — Cab.....	502-02-5	Toe Adjustment	204-00-17
Support Straps	310-01A-12	Tonneau Cover	501-00-4
Support Straps — In-Bed Tank Assembly, Upper.....	310-01B-31	Tonneau Cover — Side Rail	501-04-9
Support Straps — Mid-Ship Tank	310-01B-31	Tonneau Cover — Side Rail End Cap.....	501-04-11
Suspension System	204-00-6	Torque Converter, Description and Operation.....	307-01B-16
Inspection and Verification.....	204-00-6	Torque Converter, Disassembly and Assembly of Subassemblies	307-01A-274
Symptom Chart	204-00-7	Torque Converter, Disassembly and Assembly of Subassemblies	307-01B-233
Component Tests	204-00-13	Torque Converter Cleaning and Inspection, Disassembly and Assembly of Subassemblies.....	307-01A-274
Switch — Clutch Pedal Position (CPP)	303-06-31	Torque Converter Cleaning and Inspection, Disassembly and Assembly of Subassemblies.....	307-01B-233
Switch — Deactivator.....	310-03-35	Torque Converter Diagnosis.....	307-01B-34
Switch — Door Open Warning Lamp	413-09-32	Torque Converter End Play Check	307-01B-238
Switch — Relay Solenoid	303-06-26	Torque Converter Flushing, Disassembly and Assembly of Subassemblies.....	307-01A-276
Switch — Seat Regulator Control.....	501-10-11	Torque Converter Flushing, Disassembly and Assembly of Subassemblies.....	307-01B-235
Switch — Speed Control Actuator	310-03-34	Torque Converter Impeller to Pump Stator Interference Check, Disassembly and Assembly of Subassemblies	307-01A-278
Switches	412-04-6	Torque Converter Impeller to Pump Stator Interference Check, Disassembly and Assembly of Subassemblies	307-01B-237
Synchronizer — Camshaft, 4.2L	303-14-5	Torque Converter Leak Check, Disassembly and Assembly of Subassemblies.....	307-01A-276
Synchronizers	308-03-42	Torque Converter Leak Check, Disassembly and Assembly of Subassemblies.....	307-01B-235
System Flushing.....	211-00-9	Torque Converter One-Way Clutch Check, Disassembly and Assembly of Subassemblies.....	307-01A-280
		Torque Converter One-Way Clutch Check, Disassembly and Assembly of Subassemblies.....	307-01B-239
		Torque Converter Turbine to Pump Stator Interference Check, Disassembly and Assembly of Subassemblies	307-01A-281
		Torque Converter Turbine to Pump Stator Interference Check, Disassembly and Assembly of Subassemblies	307-01B-240
		Torque Multiplication Conversion	310-00B-33
		Torsion Bar	204-01B-16

T

Tailgate Latch	501-14-109
Tailgate Latch Remote Control.....	501-14-124
Tailgate Lock Cylinder	501-14-121
Tailgate Release Handle	501-14-120
Tank — Compressed Natural Gas (CNG)	310-01C-7
Tank — Forward In-Bed	310-01B-22
Tank — Fuel	310-01A-3
Tank — Fuel, Lightning.....	310-01A-8
Tank — Liquefied Petroleum Gas (LPG)	310-01C-3
Midship	310-01B-16
.....	310-01B-26
.....	310-00C-27
.....	303-03A-21
.....	303-03A-22



BUY IT NOW!

Click Here To Order



Alphabetical Index

Tracer Dye Leak Detection	412-00-82
Trailer Lamps	417-01-49
Symptom Chart	417-01-49
Inspection and Verification	417-01-49
Pinpoint Tests	417-01-50
Transfer Case, Description and Operation	308-07A-2
Transfer Case, Description and Operation	308-07B-2
Transfer Case, Diagnosis and Testing	308-07B-4
Transfer Case, Disassembly and Assembly	308-07B-18
Transfer Case, Installation	308-07B-47
Transfer Case, Removal	308-07B-14
Transfer Case — Electronic Shift on the Fly (ESOF)	
Features	308-07A-4
Transfer Case — Electronic Shift on the Fly (ESOF)	
Operation	308-07A-3
Transfer Case — ESOF	308-07A-4
Inspection and Verification — Electronic Shift on	
the Fly (ESOF)	308-07A-7
Symptom Chart — Electronic Shift on the Fly	
(ESOF)	308-07A-13
Pinpoint Tests	308-07A-14
Transfer Case — Mechanical Shift On The Fly	
(MSOF) Operation	308-07A-3
Transfer Case — MSOF	308-07A-105
Inspection and Verification	308-07A-106
Symptom Chart	308-07A-112
Pinpoint Tests	308-07A-113
Transfer Case — Power Flow	308-07A-2
Transfer Case Draining and Filling	308-07B-51
Transfer Case Shift Motor — Electric Shift	308-07B-11
Transmission, Assembly	307-01A-283
Transmission, Assembly	307-01B-241
Transmission, Assembly	308-03-42
Transmission, Disassembly	307-01A-187
Transmission, Disassembly	307-01B-172
Transmission, Disassembly	308-03-17
Transmission, Installation	307-01A-314
Transmission, Installation	307-01B-263
Transmission, Installation	308-03-57
Transmission, Removal	307-01A-181
Transmission, Removal	307-01B-166
Transmission, Removal	308-03-12
Transmission Connector Layouts	307-01B-52
Transmission Control Switch	307-05-18
Transmission Cooling, Description and Operation	307-02-2
Transmission Cooling, Diagnosis and Testing	307-02-6
Inspection and Verification	307-02-6
Symptom Chart	307-02-7
Transmission Description	307-01A-3
Transmission Drive Cycle Test	307-01B-43
Transmission Electronic Control System,	
Description and Operation	307-01B-27
Digital Transmission Range (TR) Sensor	307-01B-27
Transmission Filler Tube, In-Vehicle Repair	307-01A-141
Transmission Filler Tube, In-Vehicle Repair	307-01B-129
Transmission Fluid Cooler	307-01B-97
Transmission Fluid Cooler — Backflushing and	
Cleaning, General Procedures	307-01A-320
Transmission Fluid Cooler — Backflushing and	
Cleaning, General Procedures	307-01B-269
Transmission Fluid Cooler Tubes	307-02-16
Transmission Fluid Drain and Refill	307-01A-135
Transmission Insulator and Retainer, In-Vehicle	
Repair	307-01A-178
Transmission Insulator and Retainer, In-Vehicle	
Repair	307-01B-160
Transmission Support Crossmember	307-01B-164
Trim Panel — Corner, Upper	501-05-13
Trim Panel — Rear Door	501-05-2
Turbine Shaft Speed (TSS) Sensor and Output Shaft	
Speed (OSS) Sensor	307-01A-153
Turn Signal and Hazard Lamps	417-01-26
Inspection and Verification	417-01-26
Pinpoint Tests	417-01-27
Symptom Chart	417-01-27

Universal Joint Flange — Front	205-03-9
Universal Joints	205-01-5
Universal Transmitter, Description and Operation	419-02-2
Universal Transmitter, Diagnosis and Testing	419-02-2
Inspection and Verification	419-02-2
Pinpoint Tests	419-02-3
Symptom Chart	419-02-3
Upper Intake Manifold	303-01A-10

U

Vacuum Control Motor — Air Inlet Door	412-04-13
Vacuum Control Motor — Panel/Defrost Door	412-04-13
Vacuum Control Motor — Panel/Floor Door	412-04-10
Vacuum Hose Repair — Mini-Tube	412-00-98
Vacuum Reservoir — Auxiliary	205-03-7
Vacuum Reservoir — Engine	205-03-6
Vacuum Reservoir Tank and Bracket	412-04-14
Valve	206-09A-48
Valve — Evaporative Emission Canister Purge	303-13-37
Valve — Fuel Vapor Vent	303-13-38

V

Vacuum Control Motor — Air Inlet Door	412-04-13
Vacuum Control Motor — Panel/Defrost Door	412-04-13
Vacuum Control Motor — Panel/Floor Door	412-04-10
Vacuum Hose Repair — Mini-Tube	412-00-98
Vacuum Reservoir — Auxiliary	205-03-7
Vacuum Reservoir — Engine	205-03-6
Vacuum Reservoir Tank and Bracket	412-04-14
Valve	206-09A-48
Valve — Evaporative Emission Canister Purge	303-13-37
Valve — Fuel Vapor Vent	303-13-38



BUY IT NOW!

Click Here To Order



Alphabetical Index

Valve — Guide Inner Diameter	303-00-39	Weld Nut Repair — Missing Weld Nut, Restraints Control Module (RCM)	501-20B-133
Valve — Guide Reaming	303-00-39	Weld Nut Repair — Stripped Weld Nut, Restraints Control Module (RCM)	501-20B-135
Valve — Inspection	303-00-39	Wheel	211-04-8
Valve — Seals	303-01B-131	Toe	204-00-3
Valve — Seat Inspection	303-00-41	Camber	204-00-3
Valve — Seat Runout	303-00-42	Wheel Alignment Angles	204-00-3
Valve — Seat Width	303-00-42	Ride Height	204-00-4
Valve — Spring Free Length	303-00-40	Wheel Track	204-00-4
Valve — Spring Installed Length	303-00-40	Dogtracking	204-00-5
Valve — Spring Squareness	303-00-40	Drift/Pull	204-00-5
Valve — Spring Strength	303-00-41	Poor Returnability/Sticky Steering	204-00-5
Valve — Springs	303-01B-129	Wander	204-00-5
Valve — Stem Diameter	303-00-37	Shimmy	204-00-5
Valve — Stem to Valve Guide Clearance	303-00-38	Nibble	204-00-5
Valve Cover — LH	303-01B-66	Wheel and Tire	204-04-5
Valve Cover — RH	303-01B-76	Wheel Bearing Check	100-04-99
Valve Cover LH	303-01A-27	Wheel Bearing Inspection	204-00-14
Valve Cover RH	303-01A-30	Wheel Cylinder, Disassembly and Assembly	206-02-14
Valve Spring	303-01A-45	Wheel Cylinder, Removal and Installation	206-02-12
Valve Tappet	303-01A-48	Wheel Hub	204-01B-3
Valve Tappet — Inspection	303-00-37	Wheel Leaks	204-04-7
Vehicle Demagnetizing	419-11-13	Wheel Studs, Removal and Installation	204-01A-4
Vehicle Speed Control, Description and Operation	310-03-2	Wheel Studs, Removal and Installation	204-01B-7
Vehicle Speed Control, Diagnosis and Testing	310-03-2	Wheel Studs, Removal and Installation	204-02-5
Principles of Operation	310-03-2	Wheels and Tires, Description and Operation	204-04-2
Inspection and Verification	310-03-3	Wheels and Tires, Diagnosis and Testing	204-04-2
Self-Test Diagnostics	310-03-3	Inspection and Verification	204-04-3
Symptom Chart	310-03-4	Component Tests	204-04-4
Pinpoint Tests	310-03-5	Symptom Chart	204-04-4
Video Cassette Player	415-07-2	Window Control Switch	501-11-52
Video System, Description and Operation	415-07-2	Window Glass — Back	501-11-56
Video System, Diagnosis and Testing	415-07-2	Window Glass — Rear Side	501-11-53
Visual Inspection	307-01B-37	Windshield Glass	501-11-71
Voltage Regulator	414-02-6	Wiper Blade and Pivot Arm Adjustment — Windshield	501-16-68
W			
Warning Devices	413-09-2	Wipers and Washers	501-16-2
Warning Indicator Bulb	413-01A-85	Wipers and Washers — GEM/CTM	501-16-2
Washer Pump and Reservoir	501-16-65	Inspection and Verification	501-16-2
Water Pump, Removal and Installation	303-03A-24	Symptom Chart	501-16-8
Water Pump, Removal and Installation	303-03B-7	Pinpoint Tests	501-16-9
Weld Nut Repair — "J" Nut, Restraints Control Module (RCM)	501-20B-132	Wiring Harness — Fuel Charging	303-04C-11
		Wiring Repair	501-20B-131



Ford Motor Company

**TECHNICAL
SUPPORT OPERATIONS**
Automotive Consumer Services Group

100% SATISFACTION GUARANTEED

BUY IT NOW!

Click Here To Order 

LITHO IN U.S.A.
PG-2392



FCS-12272-01-2