

Ford Motor Company

2001 Wiring Diagrams

[Buy Now](#)



DEMO

This DEMO contains only a few pages of the entire manual/product.

Not all Bookmarks work on the Demo, but they do on the full version.

Features:

- Searchable text
- Printable pages
- Bookmarks for easy navigation



BUY IT NOW!

[Click Here To Order](#)



download



F-150

Copyright © 2024, Forel Publishing Company, LLC, Woodbridge, Virginia

All Rights Reserved. No part of this book may be used or reproduced in any manner whatsoever without written permission of Forel Publishing Company, LLC. For information write to Forel Publishing Company, LLC, Woodbridge, VA 22192

2001 Ford F-150 Truck Wiring Diagrams

EAN: 978-1-60371-486-0

ISBN: 1-60371-486-3

Forel Publishing Company, LLC
Woodbridge, VA 22192
Email: sales@ForelPublishing.com
<https://www.ForelPublishing.com>



License #84356800

This publication contains material that is reproduced and distributed under a license from Ford Motor Company. No further reproduction or distribution of the Ford Motor Company material is allowed without the express written permission of Ford Motor Company.

Note from the Publisher

This product was created from the original Ford Motor Company's publication. Every effort has been made to use the original scanned images, however, due to the condition of the material; some pages have been modified to remove imperfections.

Disclaimer

Although every effort was made to ensure the accuracy of this book, no representations or warranties of any kind are made concerning the accuracy, completeness or suitability of the information, either expressed or implied. As a result, the information contained within this book should be used as general information only. The author and Forel Publishing Company, LLC shall have neither liability nor responsibility to any person or entity with respect to any loss or damage caused, or alleged to be caused, directly or indirectly by the information contained in this book. Further, the publisher and author are not engaged in rendering legal or other professional services. If legal, mechanical, electrical, or other expert assistance is required, the services of a competent professional should be sought.



WIRING DIAGRAMS FCS-12263-01

FORD CUSTOMER SERVICE DIVISION

Quality is Job 1

Ford Customer Service Division has developed a new format for the 2001 F-150 Wiring Diagrams. Our goal is to provide accurate and timely electrical information.

2001 Wiring Diagrams Features

- Schematic pages now contain **Component Location** references to full-view illustrations and **Component Descriptions** that describe the system function of a component.
- **"COMPONENT TESTING"** procedures (CELL 149) that tell the user how to perform diagnostic tests on various circuits.
- **Connector End Views** are now located at the end of individual cells and are shown for connectors with five or more cavities; a circuit function chart is provided.
- **NOTES, CAUTIONS and WARNINGS** contain important safety information.
- Full view **"COMPONENT LOCATION VIEWS"** (CELL 151) to help locate on-vehicle components.
- Circuit voltages have been added to schematic pages to help simplify troubleshooting. Nonessential troubleshooting hints have been deleted.
- **Cellular Pagination:** A specific section (or cell) in all Wiring Diagrams is numbered by cell and starts with page 1. For example: **"HOW TO USE THIS MANUAL"** is CELL 2 and begins with page 2-1.
- **"IN-LINE CONNECTOR FACES"** (CELL 150) has been added for in-line connectors with six or more terminals, to aid in servicing electrical wiring.
- "C" numbers have been assigned for all electrical connectors. "C" numbers are listed in the **"LOCATION INDEX"** (CELL 152).
- **"WARRANTY CONCERN CAUSAL PART NUMBERS"** (CELL 153) has been added to aid in identifying warranty concerns.

suffix to denote connector "gender" type (F-socket, M-prior blade).

is contained in this manual were in effect at the time this manual was
Company reserves the right to discontinue models at any time, or change
e and without incurring any obligation.

ORDERING INFORMATION

To obtain information about ordering additional copies of this publication or to order any other Ford or Lincoln/Mercury publications, call 1-800-782-4356. Available publications include workshop manuals, wiring diagrams, PC/ED Manuals and Owner Guides.

In addition, you can obtain a publications order form by writing to: Ford Publications, care of Helm Inc., P.O. Box 07150, Detroit, MI 48207.

All rights reserved. Reproduction by any means, electronic or mechanical, including photocopying, recording, or by any information storage and retrieval system or translation in whole or part is not permitted without written authorization from Ford Motor Company.

Copyright © 2000, Ford Motor Company



1-1 TABLE OF CONTENTS/INDEX

2001 F-150

Table of Contents

How to Use This Manual	2-1
Grounds	10-1
Fuse Panel/Circuit Protection	11-1
Charging System	12-1
Power Distribution	13-1
Multiplex Communication Network ...	14-1
Starting System	20-1
Ignition System	21-1
Engine Controls (5.4L Bi-Fuel)	22-1
Engine Controls (4.2L)	23-1
Engine Controls (4.6L)	24-1
Engine Controls (5.4L)	25-1
Engine Controls (5.4L NGV)	26-1
Engine Controls (5.4L Sport)	27-1
Transmission Controls (4R70W)	29-1
Transmission Controls (4R100)	30-1
Speed Control	31-1
Electric Shift Control	34-1
Shift Lock	37-1
Anti-Lock Brake System (ABS)	42-1
Horn/Cigar Lighter	44-1
Air Bags	46-1
Heater	53-1
Air Conditioner/Heater	54-1
Multifunction Electronic Control	
Modules	59-1
Instrument Cluster	62-1
Warning Chime	66-1
Instrument Illumination	71-1
Interval Wiper/Washer	81-1
.....	85-1
.....	86-1
.....	87-1
.....	89-1
.....	90-1
.....	91-1

Reversing Lamps	93-1
Trailer/Camper Adapter	95-1
Daytime Running Lamps (DRL)	97-1
Power Windows	100-1
Roof Opening Panel	101-1
Overhead Console	102-1
Power Door Locks	110-1
Anti-Theft	112-1
Remote Control Alarm And Lock	
System	117-1
Heated Seats	119-1
Power Seats	120-1
Power Mirrors	124-1
Electronic Day/Night Mirror	125-1
Adjustable Pedal	127-1
Radio	130-1
Rear Seat Entertainment	132-1
Component Testing	149-1
In-Line Connector Faces	150-1
Component Location Views	151-1
Location Index	152-1
Harness Causal Part Number	153-1
Vehicle Repair Location Codes	160-1

Maxifuse 104	13-5
Maxifuse 105	13-4
Maxifuse 106	13-5
Maxifuse 108	13-6
Maxifuse 109	13-5
Maxifuse 110	13-6
Maxifuse 111	13-4, 13-7
Maxifuse 112	13-4
Maxifuse 113	13-4, 13-7
Maxifuse 115	13-6
Maxifuse 118	13-5
Minifuse 1	13-3
Minifuse 2	13-6
Minifuse 3	13-2
Minifuse 4	13-5
Minifuse 5	13-1
Minifuse 6	13-2
Minifuse 7	13-2
Minifuse 8	13-6
Minifuse 9	13-3
Minifuse 10	13-4
Minifuse 11	13-1
Minifuse 12	13-5
Minifuse 13	13-3
Minifuse 18	22-1, 23-1, 24-1, 25-1, 26-1
Minifuse 19	95-2
Minifuse 20	95-2
Minifuse 23	22-1, 23-1, 24-1, 25-1, 26-1
Minifuse 24	22-1
Battery Junction Relay Box	27-7
Belt Minder Module	66-2
Bi-Fuel Relay Module:	
Minifuse 1	11-7, 13-16
Minifuse 2	11-7, 13-16
Central Junction Box:	
Fuse 1	13-8
Fuse 2	13-8

Index

Air Bags	46-1
Air Conditioner/Heater	54-1
Anti-Lock Brakes	42-1
Anti-Theft	112-1
Battery Junction Box:	
Circuit Breaker 601	13-6
Diode (A/C Clutch)	54-3
Diode (PCM Power)	13-12
Maxifuse 101	13-3
Maxifuse 102	13-3, 13-7
Maxifuse 103	13-4

100% SATISFACTION GUARANTEED

BUY IT NOW!

Click Here To Order

PayPal American Express Discover MasterCard VISA

TABLE OF CONTENTS/INDEX 1-2

2001 F-150

Fuse 3	13-8	Multifunction Switch	149-5, 149-6	Fasten Safety Belt	62-1
Fuse 4	13-8	Power Seat Switch	149-10, 149-11	Fuel Reset Switch	62-3
Fuse 5	13-9	Right Power Door Lock Switch		High Beam	62-5
Fuse 6	13-10	(w/o Rap)	149-13	Left Turn	62-5
Fuse 8	13-10	Right Power Door Lock Switch		Low Fuel	62-3
Fuse 11	13-10	(w/Rap)	149-15	Low Oil Pressure/High Coolant	
Fuse 13	13-9	Right Power Window Switch	149-9	Temperature	62-3
Fuse 14	13-9	Courtesy Lamps	89-1	Malfunction	62-3
Fuse 15	13-9	Daytime Running Lamps (DRL)	97-1	Right Turn	62-5
Fuse 16	85-1, 87-3	Door Locks	110-1	Instrument Cluster	62-1
Fuse 18	13-11	Electric Shift Control	34-1	Instrument Illumination	71-1
Fuse 20	13-14	Fuse Panel/Circuit Protection	11-1	Interval Wiper/Washer	81-1
Fuse 21	13-14	Generic Electronic Module (GEM)/		Lamps (Exterior):	
Fuse 22	13-14	Central Timer Module (CTM)	59-1	Autolamps	87-1
Fuse 23	13-15	Grounds:		Engine Compartment	89-1
Fuse 24	13-14	G100	10-1	Fog	86-1
Fuse 25	13-14	G101	10-1, 10-2	Headlamps	85-1
Fuse 26	85-1, 86-2, 87-3	G102	10-2, 10-3	License	92-2
Fuse 27	85-1, 86-2, 87-3	G103	10-6, 10-10	Park	92-1
Fuse 28	85-1, 86-2, 87-3	G104	10-7	Reversing	93-1
Fuse 29	13-12	G105	10-1	Stop	90-2
Fuse 30	13-12	G200	10-3, 10-9	Turn	90-2
Central Security Module	117-1	G201	10-11	Lamps (Interior):	
Charging System	12-1	G202	10-12	Cargo	89-2
Cigar Lighter	44-2	G400	10-12	Glove Compartment	89-1
Component Testing	149-1	Heater	53-1	Illumination	62-4
Exterior Rear View Mirror Switch	149-16, 149-17	Horns	44-1	Interior	89-2
Ignition Switch	149-3, 149-4	Ignition System	21-1	Interior/Map	89-2
Left Power Door Lock Switch		Indicators:		Mirrors	124-1
(w/o Rap)	149-12	4 x 4 High Range	62-3	Overhead Console	102-1
Right Power Door Lock Switch		4 x 4 Low Range	62-3	Radio:	
(w/Rap)	149-14	Air Bag	62-1	AM/FM w/Cassette	130-1
Right Power Window Switch	149-9	Anti-Lock	62-4	CD Player	130-4
Seat Belt Buckle	149-8	Brake	62-1	Premium Sound	130-2, 130-3
Seat Belt Latch	149-2	Charge	62-1	Rear Seat Entertainment	132-1
Seat Belt Locking	149-19	Check Suspension	62-1	Remote Anti-theft Personality (RAP)	
Seat Belt Pretensioner	149-18	Door Ajar	62-4	Module	117-3

100% SATISFACTION GUARANTEED

BUY IT NOW!

Click Here To Order

1-3 TABLE OF CONTENTS/INDEX

2001 F-150

Seats	119-1, 120-1
Shift Lock	37-1
Speed Control	31-1
Starting System	20-1
Trailer/Camper Adapter	95-1
Transmission Controls (4R70W)	29-1
Transmission Controls (4R100)	30-1
Warning Chime	66-1
Windows	100-1

IMPORTANT SAFETY NOTICE

Appropriate service methods and proper repair procedures are essential for the safe, reliable operation of all motor vehicles, as well as the personal safety of the individual doing the work. This Manual provides general directions for accomplishing service and repair work with tested, effective techniques. Following them will help to assure reliability.

There are numerous variations in procedures, techniques, tools, and parts for servicing vehicles, as well as in the skill of the individual doing the work. This Manual cannot possibly anticipate all such variations and provide advice or cautions as to each. Accordingly, anyone who departs from the instructions provided in this Manual must first establish that the choice of methods, tools or parts does not compromise personal safety or the vehicle integrity.



BUY IT NOW!
Click Here To Order 

PayPal    

2-1 HOW TO USE THIS MANUAL

2001 F-150

The purpose of this manual is to show electrical circuits in a clear and simple fashion to make troubleshooting easier. **NOTES, CAUTIONS** and **WARNINGS** contain important information.

- **NOTES** describe how switches and other components operate to help complete a particular procedure.
- **CAUTIONS** provide information that could prevent making an error that may damage the vehicle.
- **WARNINGS** provide information to prevent personal injury.

The **WARNINGS** list on page 2-2 contains general warnings to follow when servicing a vehicle.

Components that work together are shown together. All electrical components used in a specific system are shown on one diagram. The circuit breaker or fuse is shown at the top of the page. All wires, connectors, components and splices are shown in the flow of current to ground at the bottom of the page. If a component is used in several different systems, it is shown in several places. For example, the Main Light Switch is electrically a part of many systems and is repeated on many pages.

In some cases, a component may seem (by its name) to belong to a system where it has no electrical connection. For example, Radio Illumination is electrically part of Instrument illumination, but because it has no electrical connection to the Radio system, it is not shown on the Radio diagram.

Schematic pages contain references to full-view illustrations and description notes for various components. This manual contains many blocks of text, diagrams, and illustrations. Each page and illustration are designed for easy operation.

Schematic pages contain circuit voltages to help simplify troubleshooting hints. 12V is used to imply battery voltage on a component connector terminal, and 0V is used to show that there should be continuity to ground on that particular terminal. Conditional voltages such as "12V with the ignition switch in RUN" will also be provided. Troubleshooting hints that can't be simplified with circuit voltages will be shown at the end of each cell.

Component connector face information specific to a certain cell is found at the end of that cell. A Connector Face Reference List is provided to locate connector faces that are shown in different cells. Component connectors with five or more terminals are illustrated and are accompanied by a pinout chart that lists the function of all circuitry associated with that component.

"GROUNDS" (Cell 10) contains ground circuitry shown in complete detail. This information is useful for checking interconnections of the ground circuits of different systems.

"POWER DISTRIBUTION" (Cell 13) contains power distribution circuitry shown in complete detail. This section displays how the various fuses are powered and, in turn, how each system is powered.

"COMPONENT TESTING" (Cell 149) contains testing procedures for various switches. This information includes schematics, component terminal locations and step-by-step procedures.

"IN-LINE CONNECTOR FACES" (Cell 150) contains illustrations of all the in-line connectors that have 6 or more terminals. The terminals have pin numbers assigned to them.

"COMPONENT LOCATION VIEWS" (Cell 151) contains full-view illustrations which show the location of components and connectors in the vehicle.

The **"LOCATION INDEX"** (Cell 152) provides the base part numbers, locations, connector face references and illustration references for all components, connectors, splices and grounds.

HELPFUL REMINDERS

Before using the wiring diagrams for troubleshooting, refer to these HELPFUL REMINDERS:

1. The abbreviation T/O, for take out, used in the Location Index (Cell 152), refers to the point at which a group of wires branch off the harness trunk. Refer to the wiring harness illustration.

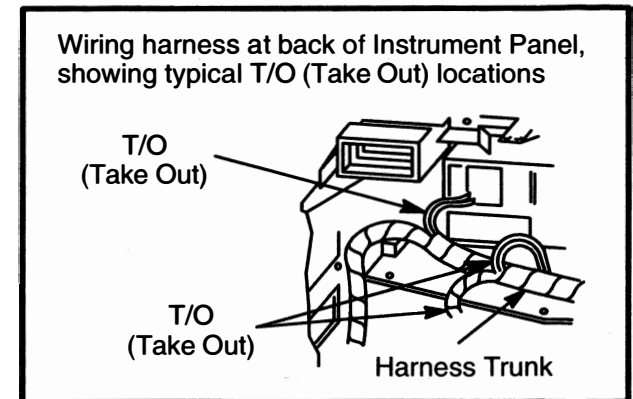

2. If a connector serves the same purpose in two separate versions (e.g., Automatic/Manual), but is physically different, *two* connector numbers are used. However, if a connector serves the same purpose in two separate versions (e.g., Automatic/Manual) and is physically the same, but the wire colors are different, only *one* connector number is used. If the same physical connector is used more than once, then more than *one* connector number is used.

100% SATISFACTION GUARANTEED

BUY IT NOW!

Click Here To Order

PayPal Discover News MasterCard VISA

3. Wiring schematics provide a picture of how and under what conditions the circuit is powered, of the current path to circuit components, and of how a circuit is grounded. Each circuit component is named (underlined titles). Wire and connector colors are listed as follows (standard Ford color abbreviations are used):

COLOR ABBREVIATIONS

BU	Blue	NA	Natural
BK	Black	OG	Orange
BN	Brown	PK	Pink
DB	Dark Blue	VT	Purple
DG	Dark Green	RD	Red
GN	Green	SR	Silver
GY	Gray	TN	Tan
LB	Light Blue	WH	White
LG	Light Green	YE	Yellow

Note: Whenever a wire is labeled with two colors, the first color listed is the basic color of the wire, and the second color listed is the stripe marking of the wire.

4. When reporting Vehicle Repair Location Codes to Ford Customer Service Division, refer to Cell 160 (beginning on page 160-1). Note: Do *not* use the illustrations in Cell 151 (beginning on page 151-1) for reporting Vehicle Repair Location Codes.

5. WARNINGS

- *Always wear safety glasses for eye protection.*
- *Use safety stands whenever a procedure requires being under a vehicle.*
- *Be sure that the Ignition Switch is always in the OFF position, unless otherwise required by the procedure.*
- *Set the parking brake when working on any vehicle. An automatic transmission should be in PARK. A manual transmission should be in NEUTRAL.*
- *Operate the engine only in a well-ventilated area to avoid danger of carbon monoxide.*
- *Keep away from moving parts, especially the fan and belts, when the engine is running.*
- *To prevent serious burns, avoid contact with hot metal parts such as the radiator, exhaust manifold, tail pipe, catalytic converter and muffler.*
- *Do not allow flame or sparks near the battery. Gases are always present in and around the battery cell. An explosion could occur.*
- *Do not smoke when working on a vehicle.*
- *To avoid injury, always remove rings, watches, loose hanging jewelry and avoid wearing loose clothing.*

HOW TO FIND ELECTRICAL CONCERNS

TROUBLESHOOTING STEPS

These six steps present an orderly method of troubleshooting.

Step 1. Verify the concern.

- Operate the complete system to check the accuracy and completeness of the customer's complaint.

Step 2. Narrow the concern.

- Using the wiring diagrams, narrow down the possible causes and locations of the concern to pinpoint the exact cause.
- Read the description notes at the components and study the wiring schematic. You should then know enough about the circuit operation to determine where to check for the trouble. Further information can be found by referring to the Service Manual pages listed in the box at the top of the page.

Step 3. Test the suspected cause.

- Use electrical test procedures to find the specific cause of the symptoms.
- The component location reference bars and the pictures will help you find components. The Location Index (at the end of the manual) gives component location information for connectors, diodes, resistors, splices and grounds.

Step 4. Verify the cause.

- Confirm that you have found the correct cause by connecting jumper wires and/or temporarily installing a known good component and operating the circuit.

Step 5. Make the repair.

- Repair or replace the inoperative component.

Step 6. Verify the repair.

- Operate the system as in Step 1 and check that your repair has removed all symptoms without creating any new symptoms.

100% SATISFACTION GUARANTEED

BUY IT NOW!

Click Here To Order

PayPal American Express Discover MasterCard VISA

2-3 HOW TO USE THIS MANUAL

2001 F-150

Some engine circuits may need special test equipment and special procedures. See the *Workshop Manual* and other service books for details. You will find the circuits in this manual to be helpful with those special test procedures.

TROUBLESHOOTING TOOLS

JUMPER WIRE

This is a test lead used to connect two points of a circuit. A Jumper Wire can bypass an open to complete a circuit.

WARNING

Never use a jumper wire across loads (motors, etc.) connected between hot and ground. This direct battery short may cause injury or fire.

VOLTMETER

A DC Voltmeter measures circuit voltage. Connect negative (- or black) lead to ground, and positive (+ or red) lead to voltage measuring point.

OHMMETER

An Ohmmeter shows the resistance between two connected points (Figure 1).

TEST LAMP

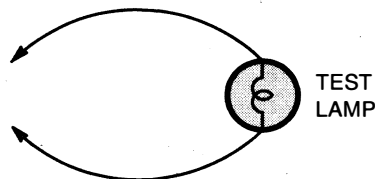

Figure 2 – Test Lamp

A Test Light is a 12-volt bulb with two test leads (Figure 2).

Uses: Voltage Check, Short Check.

SELF-POWERED TEST LAMP

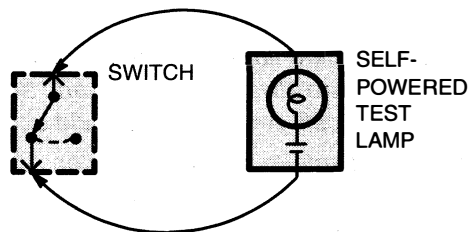

Figure 3 – Continuity Check

The Self-Powered Test Lamp is a bulb, battery and set of test leads wired in series (Figure 3). When connected to two points of a continuous circuit, the bulb glows.

Uses: Continuity Check, Ground Check.

CAUTION

When using a self-powered test lamp or ohmmeter, be sure power is off in circuit during testing. Hot circuits can cause equipment damage and false readings.

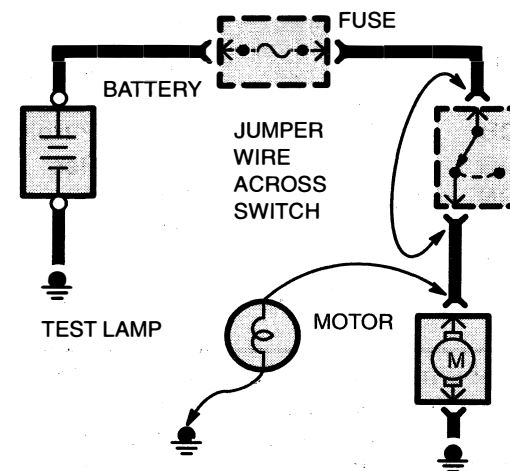

Figure 4 – Switch Circuit Check and Voltage Check

In an inoperative circuit with a switch in series with the load, jumper the terminals of the switch to power the load. If jumpering the terminals powers the circuit, the switch is inoperative (Figure 4).

CONTINUITY CHECK (Locating open circuits)

Connect one lead of Self-Powered Test Lamp or Ohmmeter to each end of circuit (Figure 3). Lamp will glow if circuit is closed. Switches and fuses can be checked in the same way.



100% SATISFACTION GUARANTEED

BUY IT NOW!

Click Here To Order

PayPal, American Express, Discover, MasterCard, VISA

VOLTAGE CHECK

Connect one lead of test lamp to a known good ground or the negative (-) battery terminal. Test for voltage by touching the other lead to the test point. Bulb goes on when the test point has voltage (Figure 4).

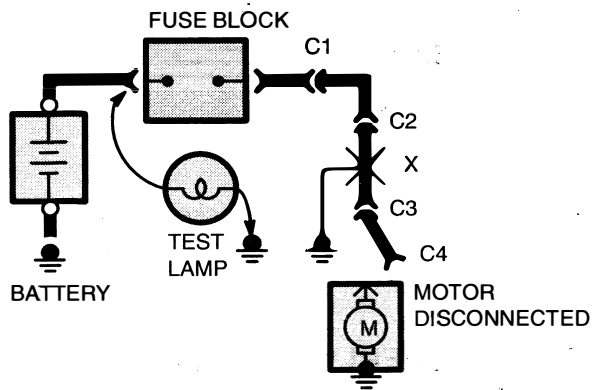

Figure 5 – Short Check

A fuse that repeatedly blows is usually caused by a short to ground. It's important to be able to locate such a short quickly (Figure 5).

1. Turn off everything powered through the fuse.
2. Disconnect other loads powered through the fuse:
 - Motors: disconnect motor connector (Connector C4 in Figure 5).

lights: remove bulbs.

(necessary) to

4. Connect one Test Lamp lead to hot end of blown fuse. Connect other lead to ground. Bulb should glow, showing power to fuse. *(This step is just a check to be sure you have power to the circuit.)*
5. Disconnect the test lamp lead that is connected to ground, and reconnect it to the load side of the fuse at the connector of the disconnected component. (In Figure 5, connect the test lamp lead to connector C4.)
 - If the Test Lamp is off, the short is in the disconnected component.
 - If the Test Lamp goes on, the short is in the wiring. You must find the short by disconnecting the circuit connectors, one at a time, until the Test Lamp goes out. For example, in Figure 5 with a ground at X, the bulb goes out when C1 or C2 is disconnected, but not after disconnecting C3. This means the short is between C2 and C3.

Turn on power to the circuit. Perform a Voltage Check between the suspected inoperative ground and the frame. Any indicated voltage means that the ground is inoperative (Figure 6).

Turn off power to the circuit. Connect one lead of a Self-Powered Test Lamp or Ohmmeter to the wire in question and the other lead to a known ground. If the bulb glows, the circuit ground is OK (Figure 6).

The circuit schematics in this manual make it easy to identify common points in circuits. This knowledge can help narrow the concern to a specific area. For example, if several circuits fail at the same time, check for a common power or ground connection (see *Power Distribution* or *Grounds*). If part of a circuit fails, check the connections between the part that works and the part that doesn't work.

For example, if the low beam headlamps work, but the high beams and the indicator lamp don't work, then power and ground paths must be good. Since the dimmer switch is the component that switches this power to the high beam lights and indicator, it is most likely the cause of failure.

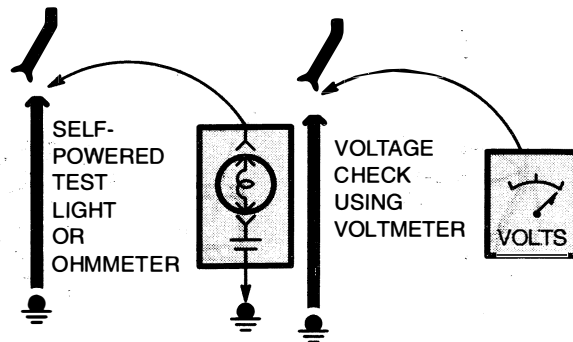

Figure 6 – Ground Check

BUY IT NOW!
 Click Here To Order 







2-5 HOW TO USE THIS MANUAL

2001 F-150

TROUBLESHOOTING WIRING HARNESS AND CONNECTOR HIDDEN CONCERNS

The following illustrations are known examples of wiring harness, splices and connectors that will create intermittent electrical concerns. The concerns are hidden and can only be discovered by a physical evaluation as shown in each illustration.

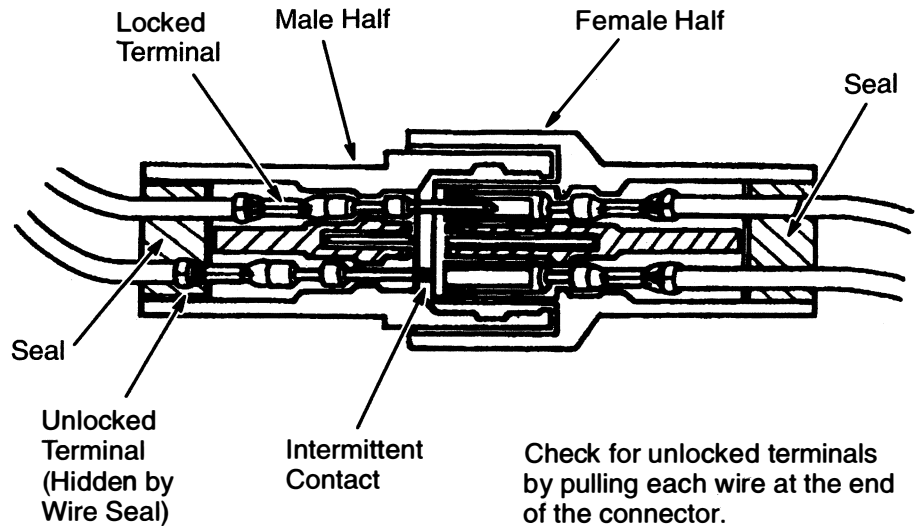
NOTE: Several components, such as the PCM, utilize gold plated terminals in their connections to the wiring harness. If those terminals need to be replaced, they must be replaced with a gold plated terminal.



TERMINAL NOT PROPERLY SEATED

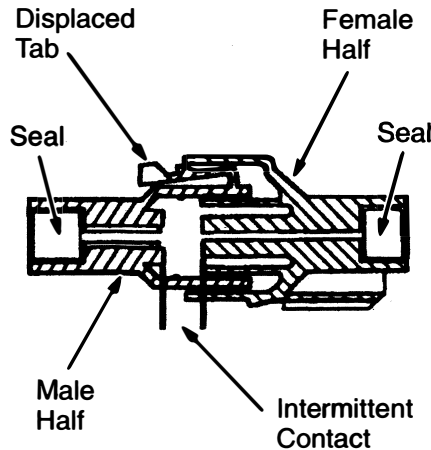
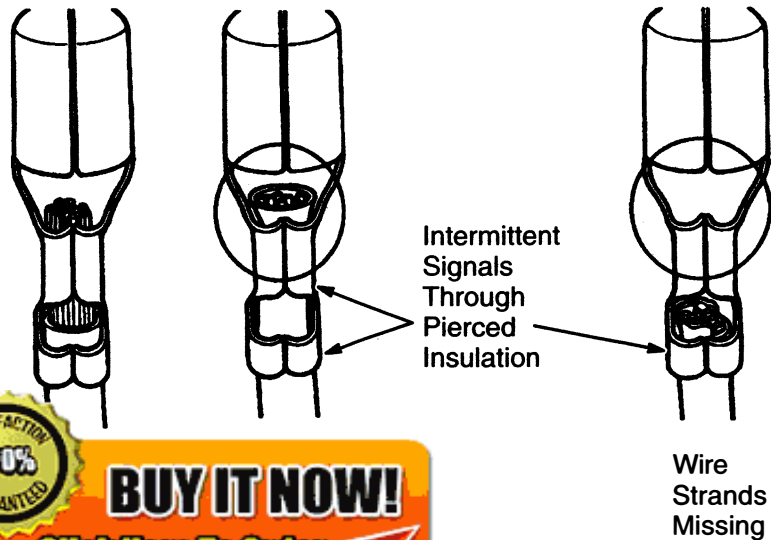

Lock may be displaced into an unlocked position; pull on the connector to verify the lock.

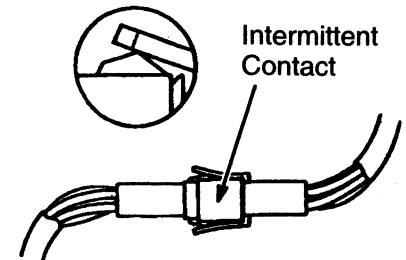

Type A

Type B

PARTIALLY MATED CONNECTORS

100% SATISFACTION GUARANTEED

BUY IT NOW!

Click Here To Order

ON STRIPPING

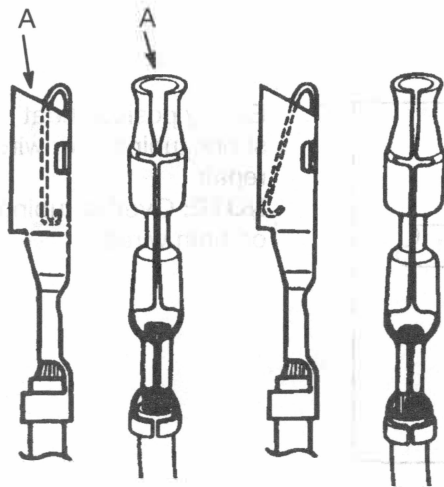

Enlarged

Normal

Any probe entering the terminal may enlarge the contact spring opening creating an intermittent signal. Insert the correct mating terminal (Location A) from the service kit and feel for a loose fit.

DEFORMED (ENLARGED) FEMALE TERMINALS

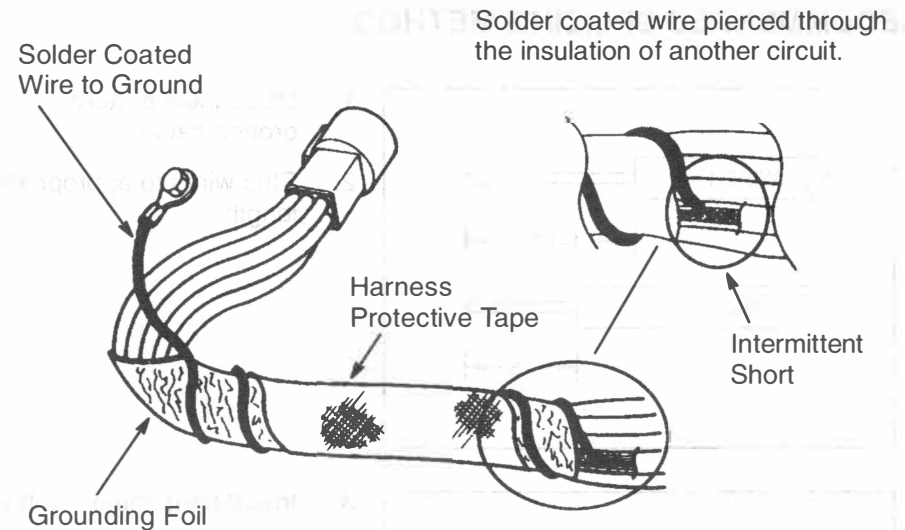

ELECTRICAL SHORT INSIDE THE HARNESS

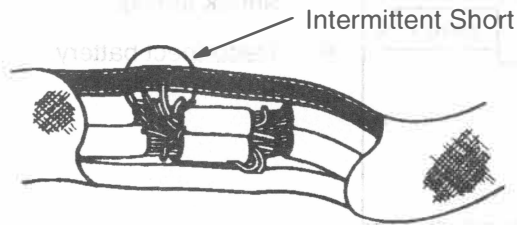

Splice Tape Removed

Intermittent Short

Operate the system and flex the harness at splice location noted in Section 152.

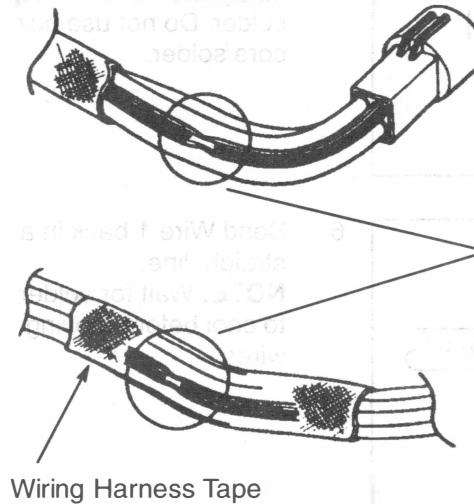

BROKEN WIRE STRANDS IN HARNESS

Remove the tape and flex/feel each circuit for a reduction in diameter at break.

100% SATISFACTION GUARANTEED

BUY IT NOW!

Click Here To Order

PayPal American Express Cards DISCOVER NOVUS MasterCard VISA

WITHIN THE HARNESS

2-7 HOW TO USE THIS MANUAL

2001 F-150

RECOMMENDED SPLICING METHOD:

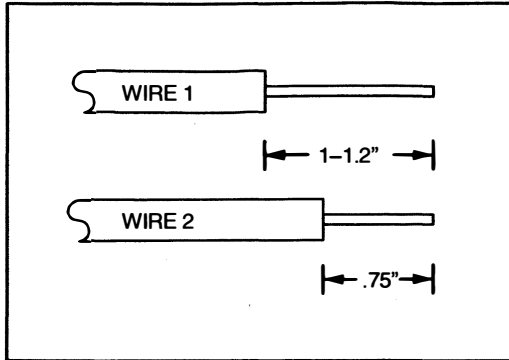

1. Disconnect battery ground cable.
2. Strip wires to appropriate length.

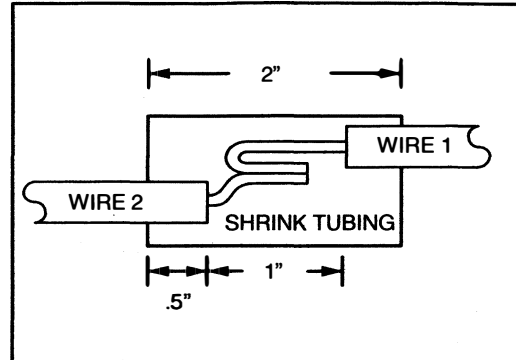

7. Evenly position heat shrink tubing over wire repair.
NOTE: Overlap tubing on both wires.

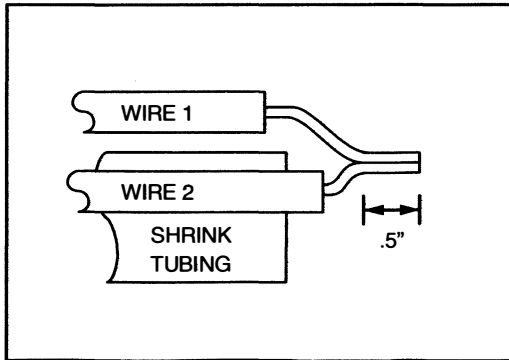

3. Install heat shrink tubing.
4. Twist wires together.
5. Solder wires together.
NOTE: Use rosin core mildly-activated (RMA) solder. Do not use acid core solder.

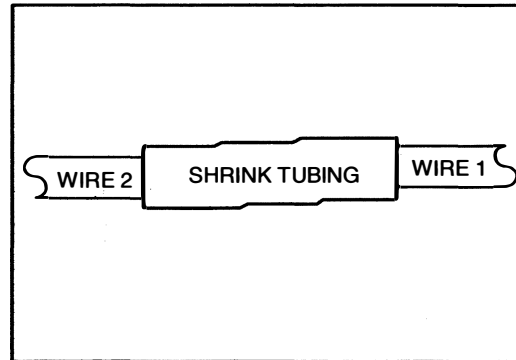

8. Use heat gun to heat the repaired area until adhesive flows out of both ends of heat shrink tubing.
9. Reconnect battery ground cable.

6. Bend Wire 1 back in a straight line.
NOTE: Wait for solder to cool before moving wires.

100% SATISFACTION GUARANTEED
BUY IT NOW!
Click Here To Order

PayPal American Express Cards DISCOVER NOVUS MasterCard VISA

ELECTRICAL SYMBOLS



DASHED COMPONENT BOX ONLY PART OF THE COMPONENT IS SHOWN ON THE PAGE; THE COMPONENT IS SHOWN COMPLETE IN ANOTHER LOCATION



COMPONENT WITH CONNECTORS

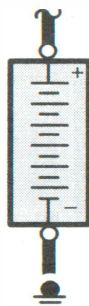

BATTERY



SCREW TERMINAL ON COMPONENT



SEALED ELECTRONIC COMPONENT ANY CIRCUITRY SHOWN INSIDE THE

100% SATISFACTION GUARANTEED

BUY IT NOW!

Click Here To Order

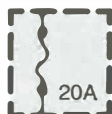

FUSE
CURRENT RATING



FUSIBLE LINK
WIRE SIZE AND COLOR



MAXI-FUSE or FUSIBLE LINK CARTRIDGE
CURRENT RATING



CIRCUIT BREAKER
CURRENT RATING

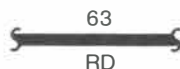

SOLID WIRES



STRIPED WIRES



SHORTING BAR

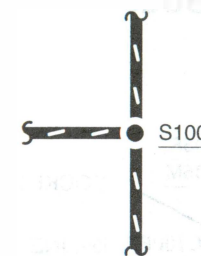

SPLICE OR CRIMP TERMINAL

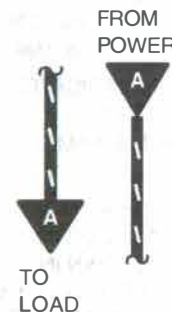

"CUT" WIRES REFERENCED BETWEEN PAGES ARROWS SHOW CURRENT FLOW FROM POWER TO GROUND



REVERSING LAMPS

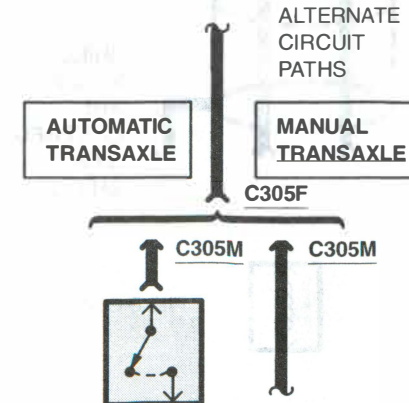

"REFERENCE" WIRES COMPLETE WIRING SHOWN ON ANOTHER PAGE

ALTERNATE CIRCUIT PATHS

2-9 HOW TO USE THIS MANUAL

2001 F-150

ELECTRICAL SYMBOLS

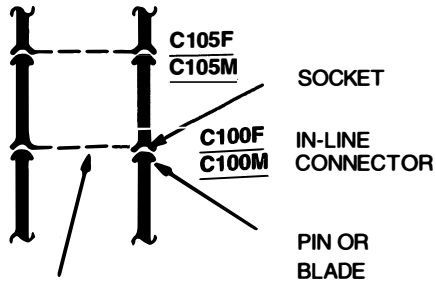

SINGLE DASHED LINE INDICATES THAT WIRE ON LEFT ALSO PASSES THROUGH THE SAME CONNECTOR

SEE GROUNDS
PAGES 10-1,
10-2

DASHED WIRE CIRCUITRY IS NOT SHOWN IN COMPLETE DETAIL, BUT IS COMPLETE ON ANOTHER PAGE

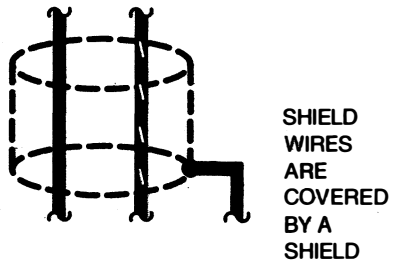

MOTOR



HEATING ELEMENT



THERMISTOR



RHEOSTAT OR POTENTIOMETER



SOLENOID

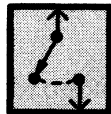

SWITCH

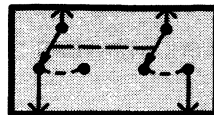

GANGED SWITCHES CONTACTS MOVE AT THE SAME TIME

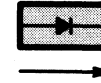

DIODES CURRENT FLOWS IN DIRECTION OF ARROW ONLY

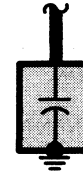

CAPACITOR



TRANSISTOR



GAUGE



LIGHT EMITTING DIODE (LED)



LIGHT BULB



DUAL FILAMENT LIGHT BULB

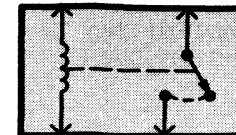

RELAY CONTACTS CHANGE POSITION WITH CURRENT THROUGH COIL

100% SATISFACTION GUARANTEED

BUY IT NOW!

Click Here To Order

100% SATISFACTION GUARANTEED

BUY IT NOW!

Click Here To Order

PayPal American Express Cards Discover NOVUS MasterCard VISA

10-1 GROUNDS

2001 F-150

All Circuits are 57 BK unless otherwise noted.

* BI-FUEL

CRANKSHAFT POSITION (CKP) SENSOR SHIELD
PAGE 21-5

POWERTRAIN CONTROL MODULE (PCM)
PAGE 22-5

CRANKSHAFT POSITION (CKP) SENSOR SHIELD
PAGES 21-1, 21-5

CAMSHAFT POSITION (CMP) SENSOR SHIELD
PAGE 22-5

POWERTRAIN CONTROL MODULE (PCM)
PAGES 23-1, 24-1, 25-1, 26-1, 27-1

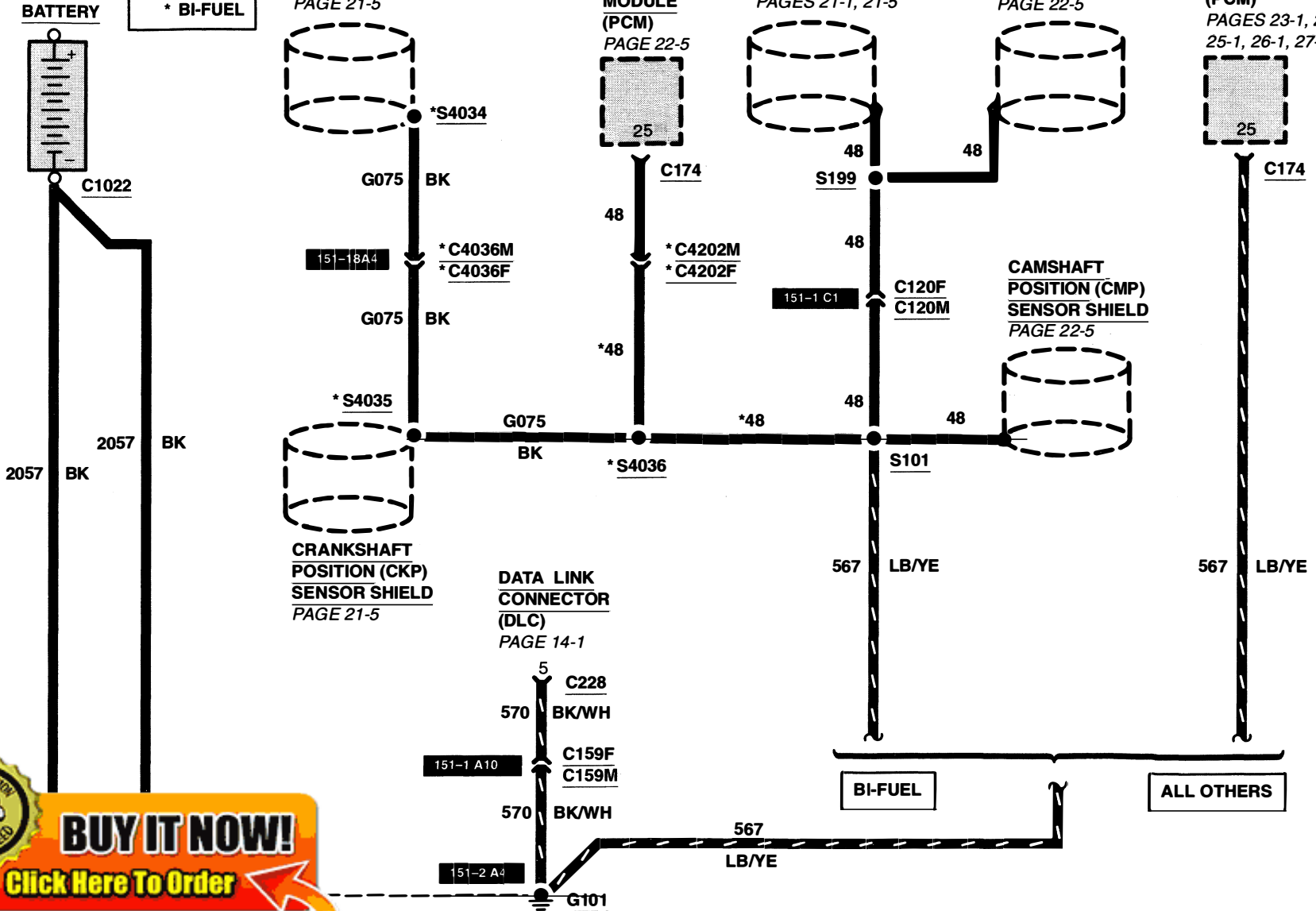

100% SATISFACTION GUARANTEED

BUY IT NOW!

[Click Here To Order](#)

(FR)

All Circuits are 57 BK unless otherwise noted.

* 4.6L/5.4L
** 4.2L

MASS AIR FLOW (MAF) SENSOR
PAGES 22-2, 23-2, 24-2, 25-2, 26-2, 27-2

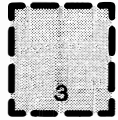

C141

570 BK/WH

ALL OTHERS

SPORT

C156F
C156M

570 BK/WH

570 BK/WH

POWERTRAIN CONTROL MODULE (PCM)
PAGES 22-1, 23-1, 24-1, 25-1, 26-1, 27-1



C174

570 BK/WH

570 BK/WH

570 BK/WH

570 BK/WH

570 BK/WH

570 BK/WH

NGV TIMER
PAGE 26-9

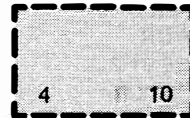

C196

570 BK/WH

570 BK/WH

570 BK/WH

151-2 A9

CAMSHAFT POSITION (CMP) SENSOR SHIELD
PAGE 23-5

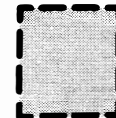

C100

C120F
C120M

57 BK

CRANKSHAFT POSITION (CKP) SENSOR SHIELD
PAGE 21-1

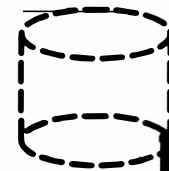

48

CRANKSHAFT POSITION (CKP) SENSOR SHIELD
PAGE 21-1

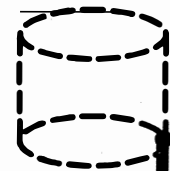

48

S199

48

151-1 C1

C120F
C120M

48

570 BK/WH

151-2 A4

G101

100% SATISFACTION GUARANTEED

BUY IT NOW!

Click Here To Order

All Circuits are 57 BK unless otherwise noted.

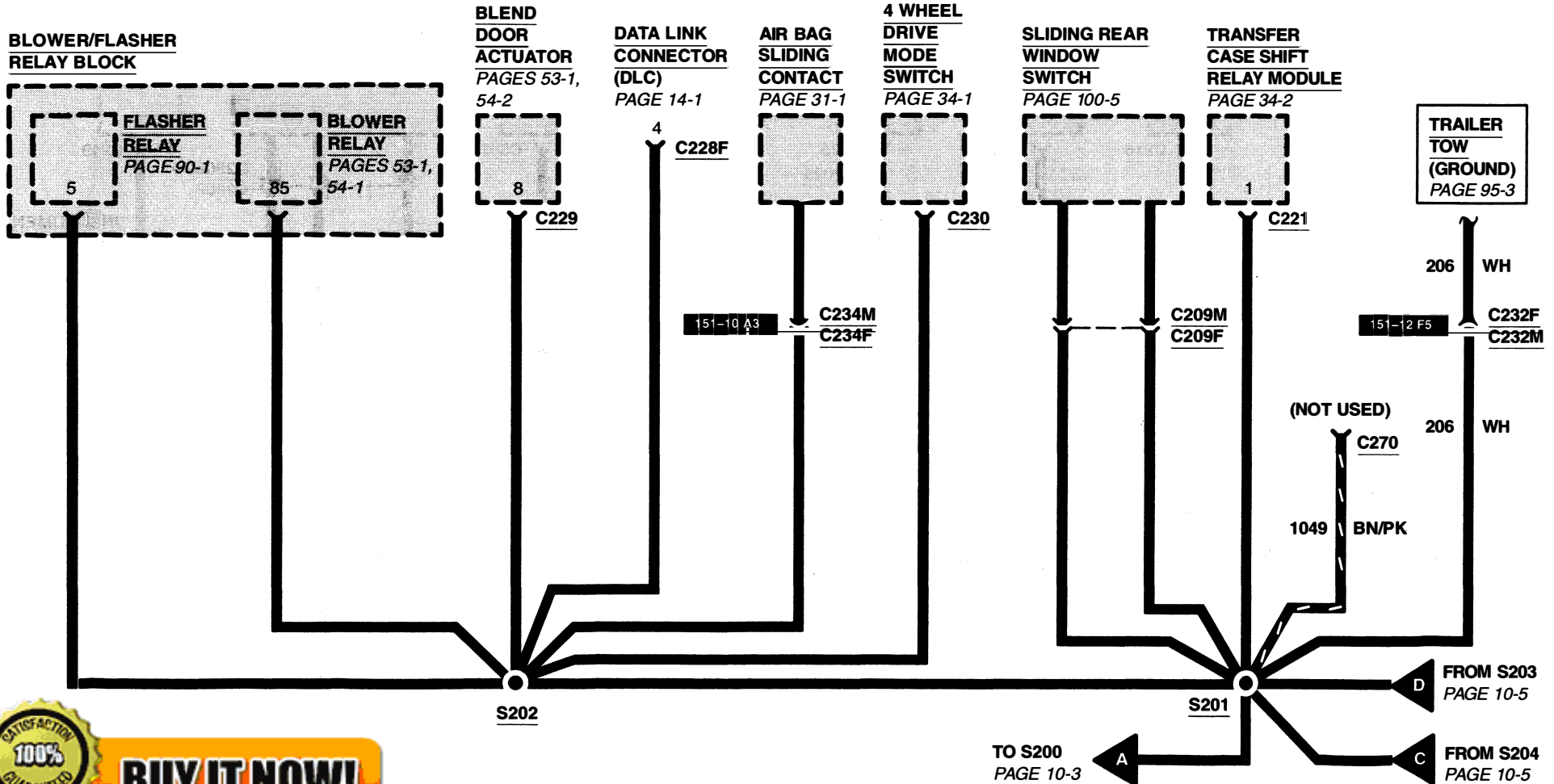

100% SATISFACTION GUARANTEED

BUY IT NOW!

Click Here To Order

10-5 GROUNDS

2001 F-150

All Circuits are 57 BK unless otherwise noted.

* W/REAR SEAT ENTERTAINMENT

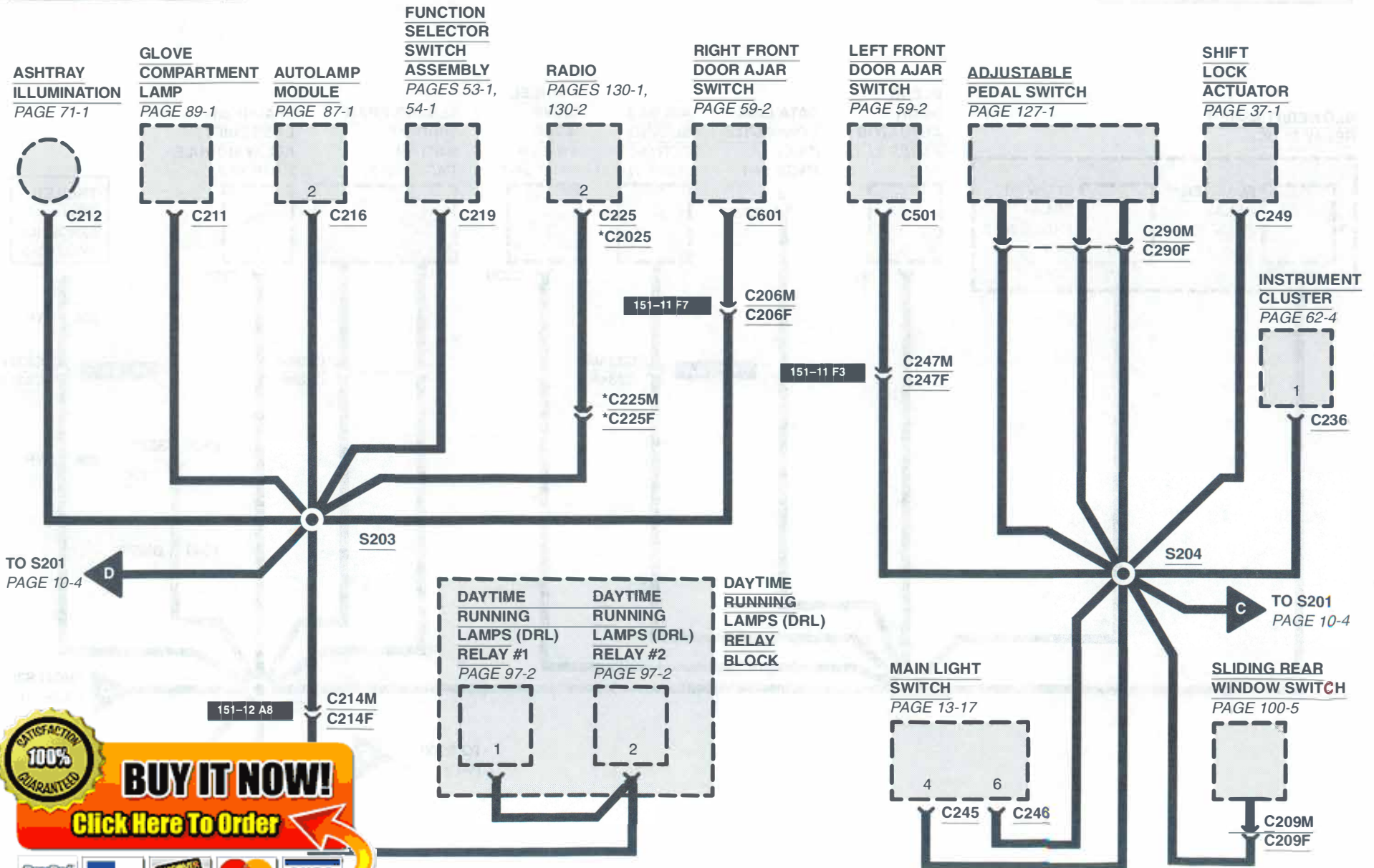

100% SATISFACTION GUARANTEED

BUY IT NOW!

Click Here To Order

PayPal | American Express | Discover | MasterCard | VISA

All Circuits are 57 BK unless otherwise noted.

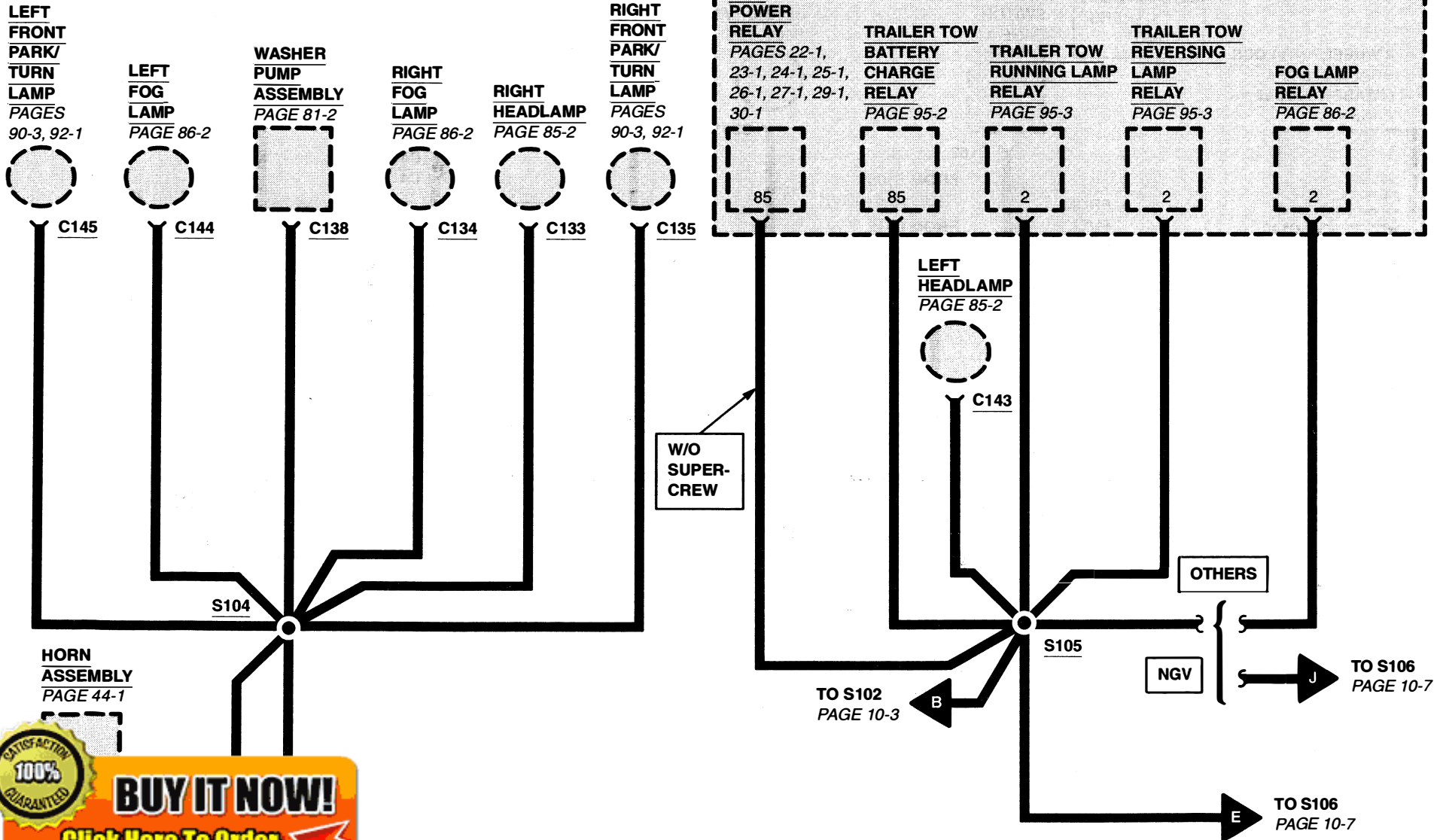

HORN ASSEMBLY PAGE 44-1

100% SATISFACTION GUARANTEED

BUY IT NOW!

Click Here To Order

PayPal, American Express, Discover, MasterCard, VISA

ENGINE CONTROLS (5.4L BI-FUEL) 22-10

2001 F-150

* LPG

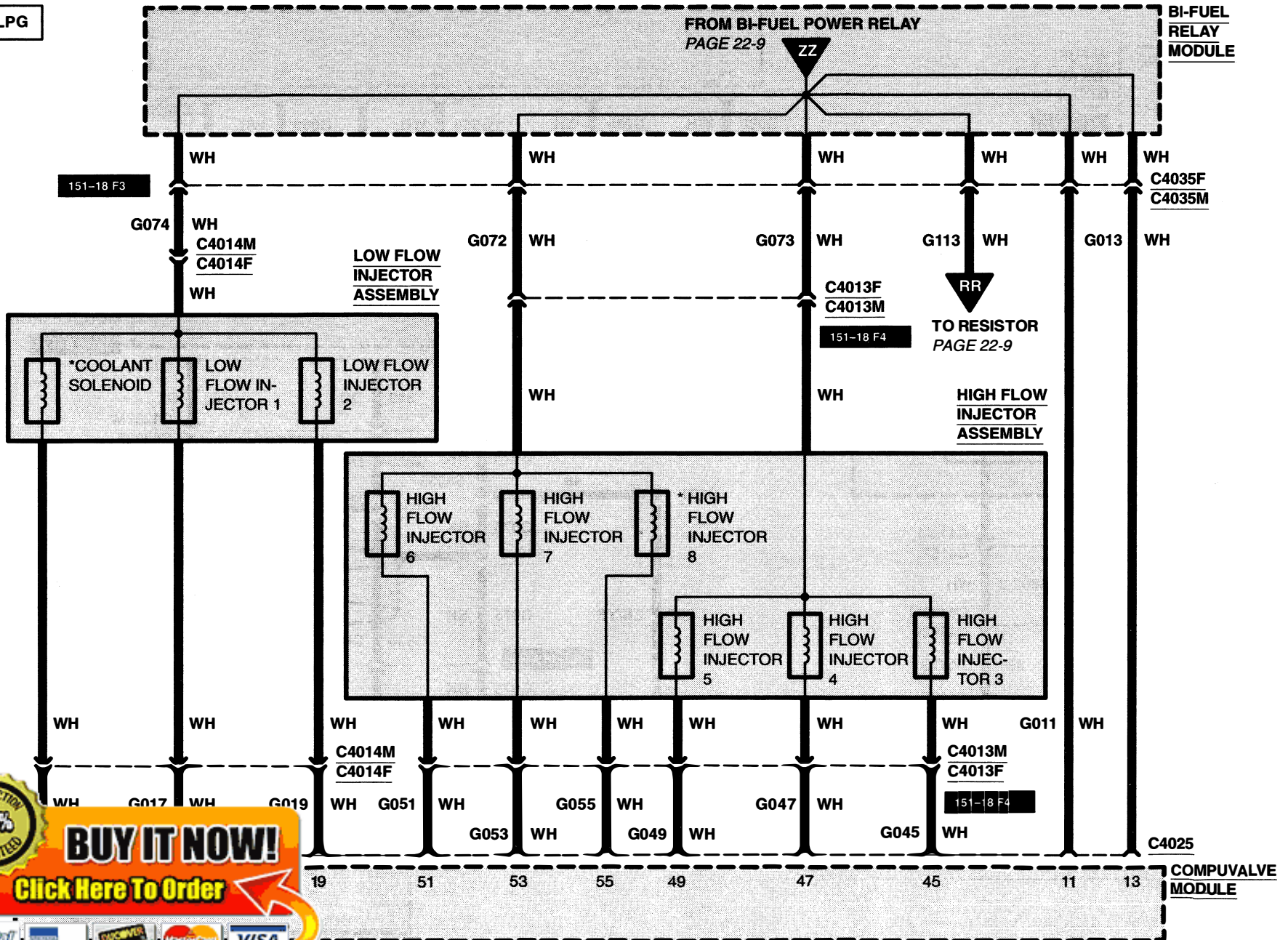

100% SATISFACTION GUARANTEED

BUY IT NOW!

Click Here To Order

PayPal

Discover

MasterCard

VISA

22-11 ENGINE CONTROLS (5.4L BI-FUEL)

2001 F-150

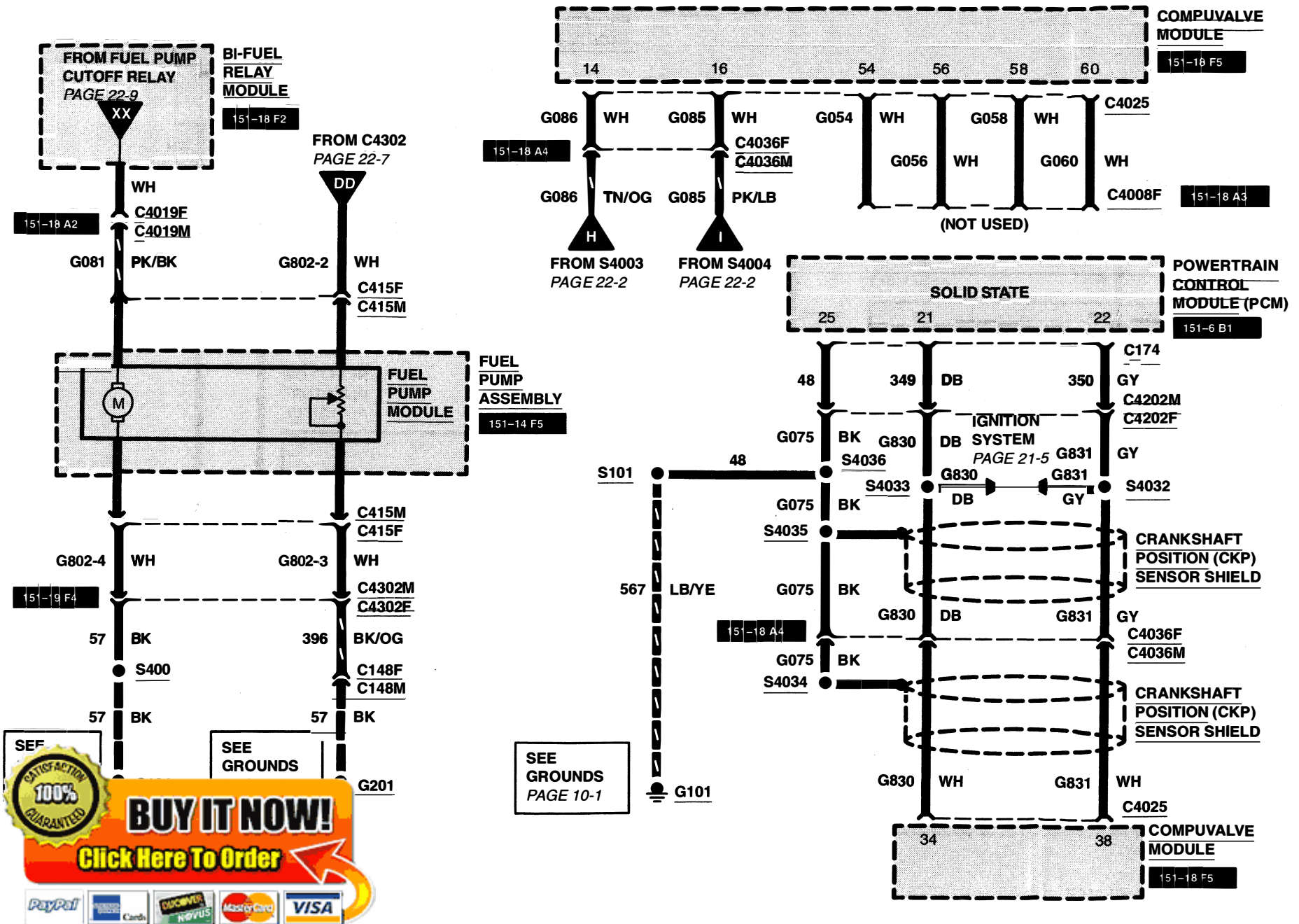

SEF

100% SATISFACTION GUARANTEED

BUY IT NOW!

Click Here To Order

PayPal, American Express, Discover, MasterCard, VISA

22-15 ENGINE CONTROLS (5.4L BI-FUEL)

2001 F-150

GFI – Ford Electrical Connections

Taps and Intercepts

There are two ways of making the electrical connections that are required by the GFI system.

A TAP is made by splicing a wire to a signal in the vehicle allowing the original connections to remain in place. With a TAP, the signal stays connected to the vehicle in all modes of operation. The GFI system can read the signal (e.g. a sensor) and modify it if necessary (e.g. a bi-directional data bus). A TAP is usually implemented by pulling a wire out of a connector and joining it to a GFI harness. A wire from the GFI harness is then inserted into the connector. The harnesses are designed to provide matching wire colors for TAPPED connections.

An INTERCEPT is made by cutting a signal path so that the source and load are routed independently to the GFI system. An INTERCEPT is made when the GFI system must completely disable a device (e.g. fuel pump) or drive a device independently of the vehicle's normal method (e.g. fuel gauge) during alternate fuel mode. During other modes, the original connections are restored. An INTERCEPT is usually implemented by disconnecting a pair of connectors in the vehicle's harness system and joining them to a matching pair of connectors included in the GFI harness. The signals of interest are routed to the GFI system. Any remaining signals are routed between the new connectors.

Taps

Tach or Crank Position Sensor (2 wires)
MIL
Bus + and Bus –
Left Front HEGO, Right Front HEGO
Throttle Position Sensor
Signal Return
Switched Battery (Hot start and run)
Battery

Intercepts

Fuel Pump Power
Fuel Gauge
Instrument Cluster Power

Notes about Fuel Gauges

These are handled in two ways.

1999 and later F-Series vehicles have their instrument cluster connected to the SCP bus (Bus + and Bus –). These vehicles do not require intercepts in the fuel gauge and instrument cluster power signals because the GFI system can send fuel level data over the SCP bus.

All other vehicles (earlier F-Series, P131, Econoline vans, Contour) require fuel gauge and cluster power intercepts to allow GFI to control the fuel gauge in alternate fuel mode and reset the cluster at fuel switchover.

100% SATISFACTION GUARANTEED

BUY IT NOW!

Click Here To Order

PayPal, American Express, Discover, MasterCard, VISA

24-3 ENGINE CONTROLS (4.6L)

2001 F-150

* START OR RUN

Solenoid actuated valve. As solenoid is energized (pulsed), fuel passes through injector into engine. The longer the pulse, the greater the fuel amount.

Controls idle speed. Duty cycle signals sent by PCM control a solenoid that opens or closes air bypass depending on signal received.

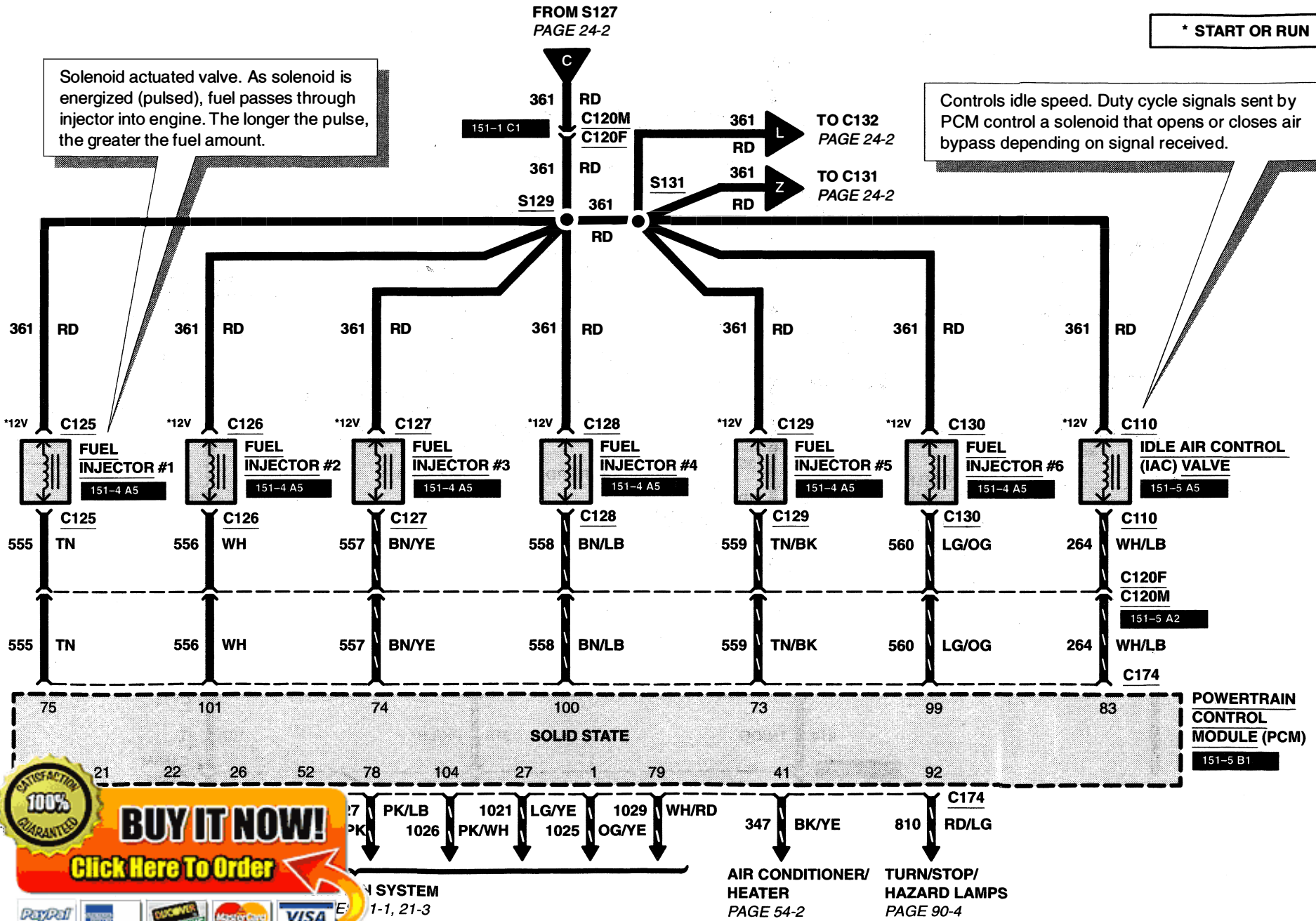

100% SATISFACTION GUARANTEED

BUY IT NOW!

Click Here To Order

PayPal American Express Discover Novus MasterCard VISA

ENGINE CONTROLS (4.6L) 24-4

2001 F-150

* START OR RUN

FROM BATTERY JUNCTION BOX
PAGE 24-1

TO S135
PAGE 24-6

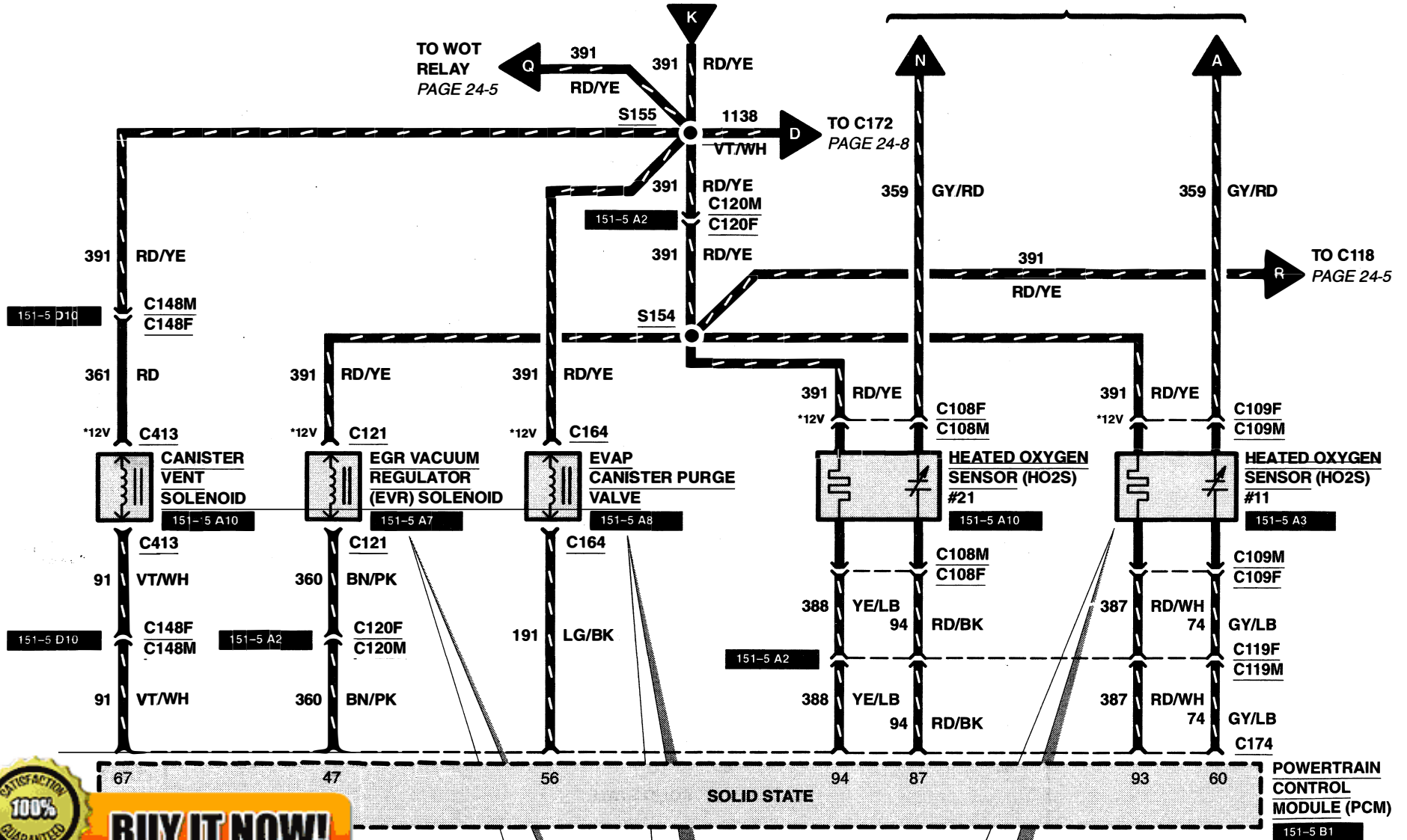

100% SATISFACTION GUARANTEED

BUY IT NOW!

[Click Here To Order](#)

PayPal, American Express, Discover, MasterCard, VISA

present in EGR valve to con-
tact manifold. PCM con-
tacts applied to the solenoid.

When PCM grounds valve, fuel
vapors which are collected are
released to engine for burning.

Provides a voltage related to oxy-
gen content of exhaust gases to
PCM for regulating air/fuel ratio.

24-5 ENGINE CONTROLS (4.6L)

2001 F-150

* START OR RUN

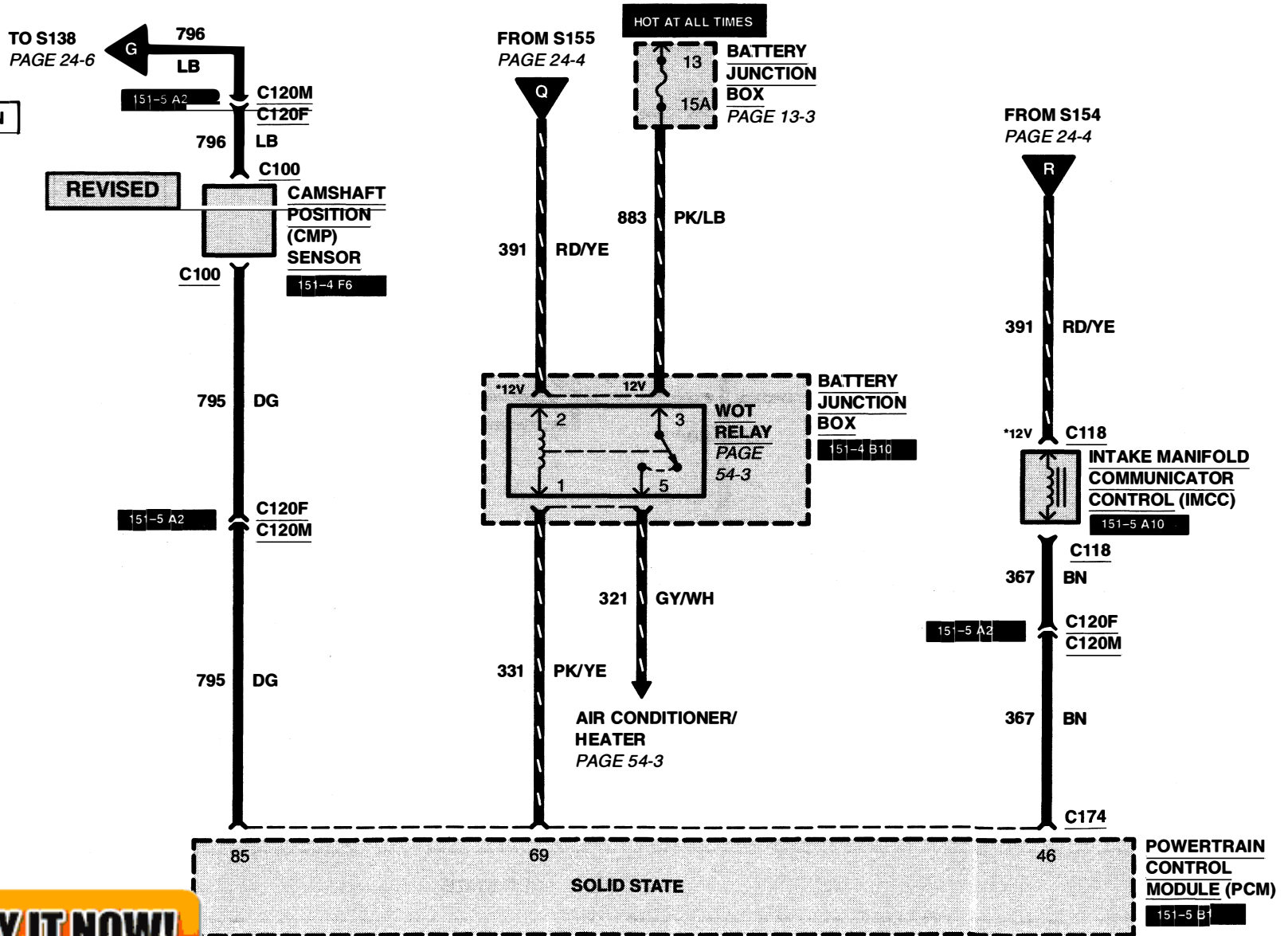

100% SATISFACTION GUARANTEED

BUY IT NOW!

Click Here To Order

24-9 ENGINE CONTROLS (4.6L)

2001 F-150

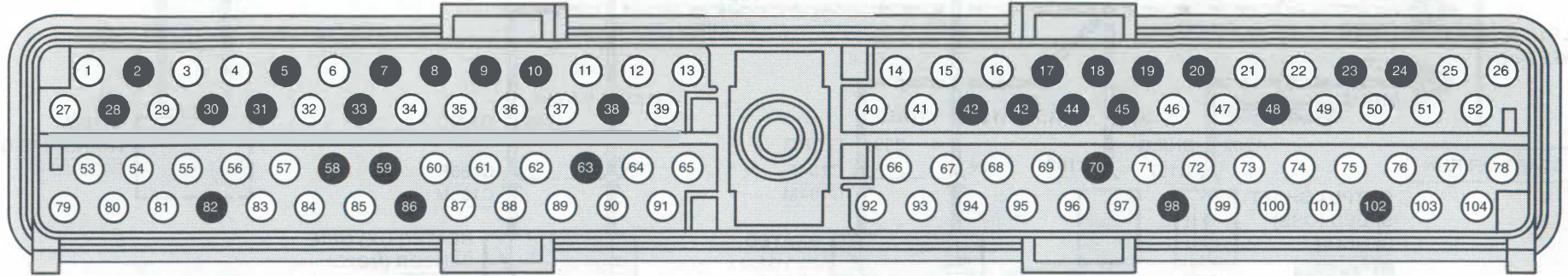

**C174 (GRAY)
POWERTRAIN CONTROL MODULE (PCM)**

PIN	CIRCUIT	CIRCUIT FUNCTION	PIN	CIRCUIT	CIRCUIT FUNCTION
1	1025 (OG/YE)	Coil on Plug #6	17	-	NOT USED
2	-	NOT USED	18	-	NOT USED
3	570 (BK/WH)	Ground	19	-	NOT USED
4	1496 (PK)	Transfer Case Speed Sensor	20	924 (BN/OG)	NOT USED
5	-	NOT USED	21	349 (DB)	Crankshaft Position (CKP) (+) Sensor
6	237 (OG/YE)	Shift Solenoid A (SSA)	22	350 (GY)	Crankshaft Position (CKP) (-) Sensor
7	-	NOT USED	23	-	NOT USED
8	-	NOT USED	24	-	NOT USED
9	-	NOT USED	25	567 (LB/YE)	Ground
10	-	NOT USED	26	1024 (LG/WH)	Ignition Coil #1
	315 (VT/OG)	Shift Solenoid B (SSB)	27	1021 (LG/YE)	Coil on Plug #5
	-	Transmission Control Indicator Lamp (TCIL)	28	-	NOT USED
	-	Bank Connector (DLC)	29	224 (TN/WH)	Transmission Control Switch (TCS)
	-	Wiper Indicator Switch	30	-	NOT USED
	-	Bus (-)	31	-	NOT USED
	-	Bus (+)	32	311 (DG/VT)	Knock Sensor (-) (KS)

100% SATISFACTION GUARANTEED

BUY IT NOW!

Click Here To Order

26-11 ENGINE CONTROLS (5.4L NGV)

2001 F-150

PIN	CIRCUIT	CIRCUIT FUNCTION	PIN	CIRCUIT	CIRCUIT FUNCTION
36	968 (TN/LB)	Mass Air Flow (MAF) Sensor	64	199 (LB/YE)	TR3A
37	923 (OG/BK)	Transmission Fluid Temperature (TFT) Sensor	65	48	NOT USED
38	-	NOT USED	66	1102 (YE/LG)	Cylinder Head Temperature (CHT) Sensor
39	743 (GY)	Intake Air Temperature (IAT) Sensor	67	-	NOT USED
40	238 (DG/YE)	Fuel Pump Monitor	68	679 (GY/BK)	Vehicle Speed Output Sensor
41	347 (BK/YE)	A/C High Pressure Cutoff Switch Input	69	331 (PK/YE)	WOT Relay
42	-	NOT USED	70	-	NOT USED
43	-	NOT USED	71	361 (RD)	Vehicle Power (VPWR)
44	-	NOT USED	72	1171 (WH)	NGV Module
45	-	NOT USED	73	1169 (WH/LB)	NGV Module
46	-	NOT USED	74	1167 (WH/BK)	NGV Module
47	-	NOT USED	75	1165 (WH/RD)	NGV Module
48	-	NOT USED	76	570 (BK/WH)	Power Ground
49	1145 (LB/BK)	TR2	77	-	NOT USED
50	1143 (WH/BK)	TR4	78	1027 (PK/LB)	Coil on Plug #7
51	570 (BK/WH)	Power Ground	79	1029 (WH/RD)	Coil on Plug #8
52	1028 (WH/PK)	Coil on Plug #3	80	926 (LB/OG)	Fuel Shutoff Valve Control
53	1030 (DG/VT)	Coil on Plug #4	81	925 (WH/YE)	Electronic Pressure Control (EPC) Solenoid
54	480 (VT/YE)	Torque Converter Clutch (TCC) Solenoid	82	-	NOT USED
55	729 (RD/WH)	Keep Alive Power (KAPWR)	83	264 (WH/LB)	Idle Air Control (IAC) Valve Control
56	-	NOT USED	84	136 (DB/YE)	Output Shaft Speed (OSS) Sensor
57	-	NOT USED	85	795 (DG)	Camshaft Position (CMP) Sensor
58	-	NOT USED	86	-	NOT USED
59	970 (DG/WH)	Turbine Shaft Speed (TSS) Sensor	87	94 (RD/BK)	Heated Oxygen Sensor #21 (HO2S)
60	74 (GY/LB)	Heated Oxygen Sensor #11 (HO2S) Input	88	967 (LB/RD)	Mass Air Flow (MAF) Sensor
61	-	NOT USED	89	355 (GY/WH)	Throttle Position (TP) Sensor
	1164 (LB)	Engine Fuel Temperature (EFT) Sensor	90	351 (BN/WH)	Reference Voltage
	141 (RD/PK)	Injector Pressure Transducer	91	359 (GY/RD)	Signal Return
			92	810 (RD/LG)	Brake Pedal Position (BPP) Switch



BUY IT NOW!

[Click Here To Order](#)



ENGINE CONTROLS (5.4L NGV) 26-12

2001 F-150

PIN	CIRCUIT	CIRCUIT FUNCTION
93	387 (RD/WH)	Heated Oxygen Sensor #11 (HO2S) Heater
94	388 (YE/LB)	Heated Oxygen Sensor #21 (HO2S) Heater
95	-	NOT USED
96	-	NOT USED
97	361 (RD)	Vehicle Power (VPWR)
98	1172 (YE)	NGV Module
99	1170 (YE/LB)	NGV Module
100	1168 (YE/BK)	NGV Module
101	1166 (YE/RD)	NGV Module
102	-	NOT USED
103	570 (BK/WH)	Power Ground
104	1026 (PK/WH)	Coil on Plug #2

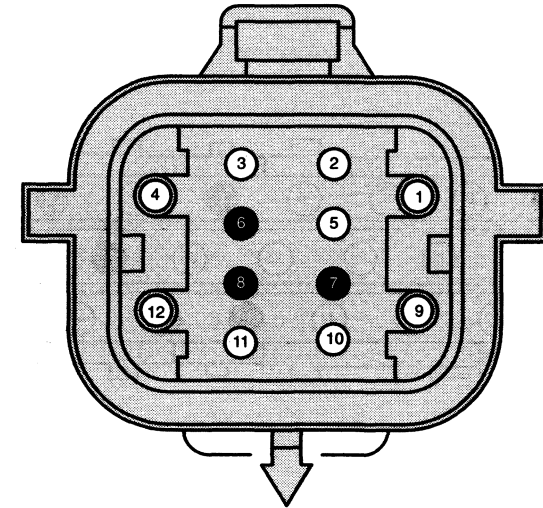

C196
NGV TIMER

PIN	CIRCUIT	CIRCUIT FUNCTION
1	1501 (BK)	Ground
2	396 (BK/OG)	Ground
3	1503 (BK/LB)	Ground
4	570 (BK/WH)	Ground
5	1093 (TN/RD)	Starter Relay Enable
6	-	NOT USED
7	-	NOT USED
8	-	NOT USED
9	16 (RD/LG)	Power
10	570 (BK/WH)	Ground
11	1502 (BK/YE)	Ground
12	1500 (RD/WH)	Power

100% SATISFACTION GUARANTEED

BUY IT NOW!

Click Here To Order

26-13 ENGINE CONTROLS (5.4L NGV)

2001 F-150

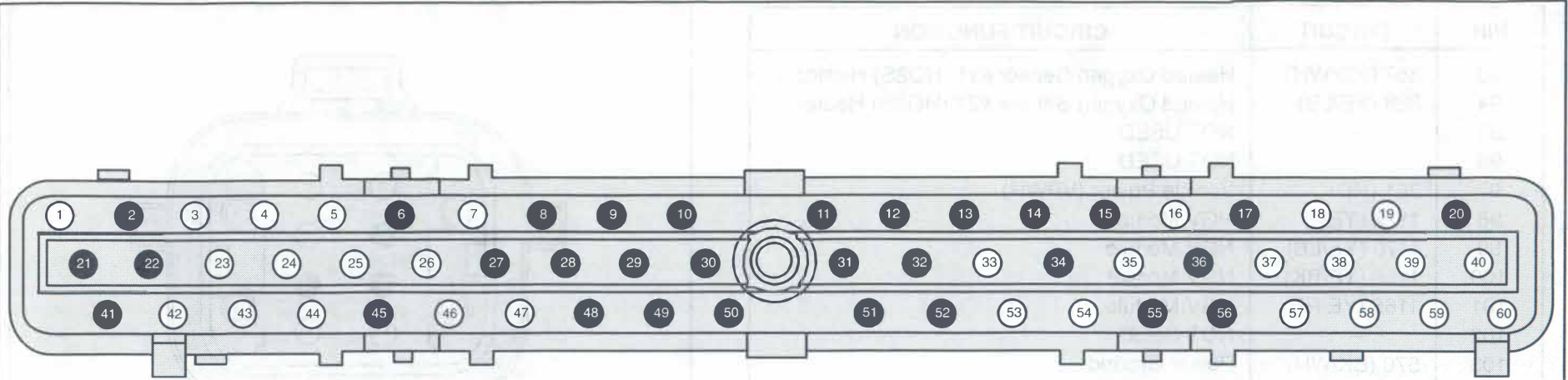

**C197
NGV MODULE**

PIN	CIRCUIT	CIRCUIT FUNCTION	PIN	CIRCUIT	CIRCUIT FUNCTION
1	729 (RD/WH)	Engine Fuse Module Feed	17	-	NOT USED
2	-	NOT USED	18	915 (PK/LB)	Bus -
3	1165 (WH/RD)	Injector Input #1	19	914 (TN/OG)	Bus +
4	1166 (YE/RD)	Injector Input #2	20	-	NOT USED
5	1167 (WH/BK)	Injector Input #3	21	-	NOT USED
6	-	NOT USED	22	-	NOT USED
7	1161 (DG/OG)	Fuel Tank Pressure Sensor Signal	23	1168 (YE/BK)	Injector Input #4
8	-	NOT USED	24	1169 (WH/LB)	Injector Input #5
9	-	NOT USED	25	1170 (YE/LB)	Injector Input #6
10	-	NOT USED	26	1160 (BN/WH)	Fuel Tank Pressure Sensor VREF
	-	NOT USED	27	-	NOT USED
	-	NOT USED	28	-	NOT USED
	-	NOT USED	29	-	NOT USED
	-	NOT USED	30	-	NOT USED
	-	NOT USED	31	-	NOT USED
	-	NOT USED	32	-	NOT USED

100% SATISFACTION GUARANTEED

BUY IT NOW!

Click Here To Order

ENGINE CONTROLS (5.4L NGV) 26-14

2001 F-150

PIN	CIRCUIT	CIRCUIT FUNCTION
33	559 (TN/BK)	Fuel Injector #5
34	-	NOT USED
35	558 (BN/LB)	Fuel Injector #4
36	-	NOT USED
37	361 (RD)	Power Input
38	29 (YE/WH)	Fuel Gauge Signal
39	557 (BN/YE)	Fuel Injector #3
40	1502 (BK/YE)	Ground
41	-	NOT USED
42	560 (LG/OG)	Fuel Injector #6
43	1171 (WH)	Injector Input #7
44	1172 (YE)	Injector Input #8
45	-	NOT USED
46	1163 (BN)	Sensor Signal Return
47	1162 (LG/RD)	Fuel Tank Temperature Sensor Signal
48	-	NOT USED
49	-	NOT USED
50	-	NOT USED
51	-	NOT USED
52	-	NOT USED
53	561 (TN/RD)	Fuel Injector #7
54	562 (LB)	Fuel Injector #8
55	-	NOT USED
56	-	NOT USED
57	361 (RD)	Power Input
58	555 (TN)	Fuel Injector #1
59	556 (WH)	Fuel Injector #2
60	1501 (BK)	Ground

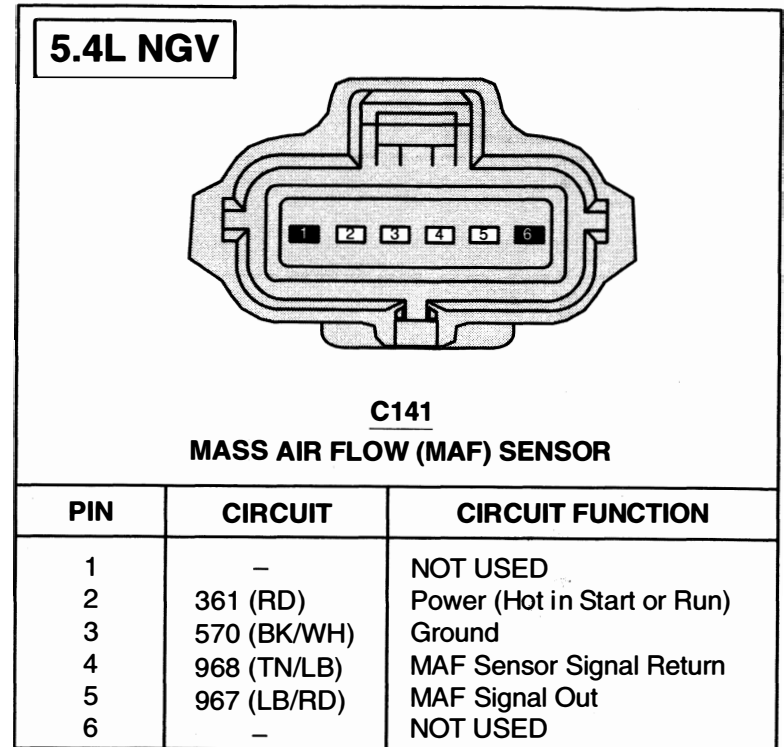

CONNECTOR REFERENCE LIST

CONNECTOR	SECTION-PAGE
C157	31-4
C182	29-5, 30-5
C224	130-5
C236	62-6
C237	62-6
C267	59-6

100% SATISFACTION GUARANTEED

BUY IT NOW!

Click Here To Order

150-15 IN-LINE CONNECTOR FACES

2001 F-150

14401

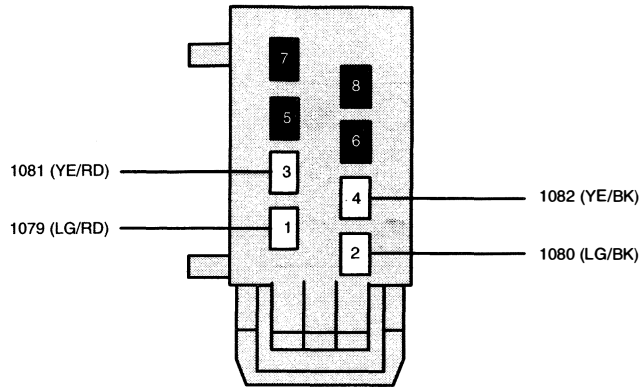

C319F

14A504

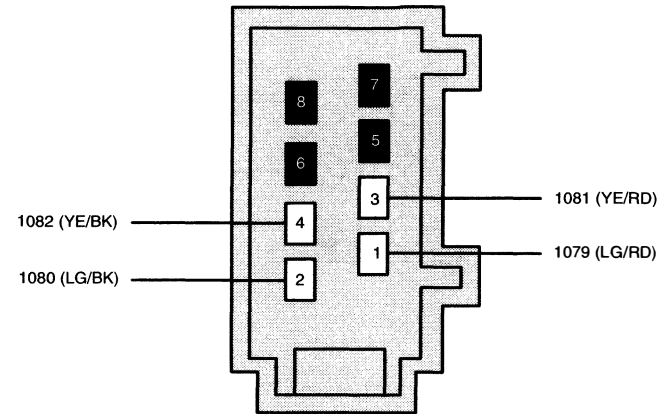

C319M

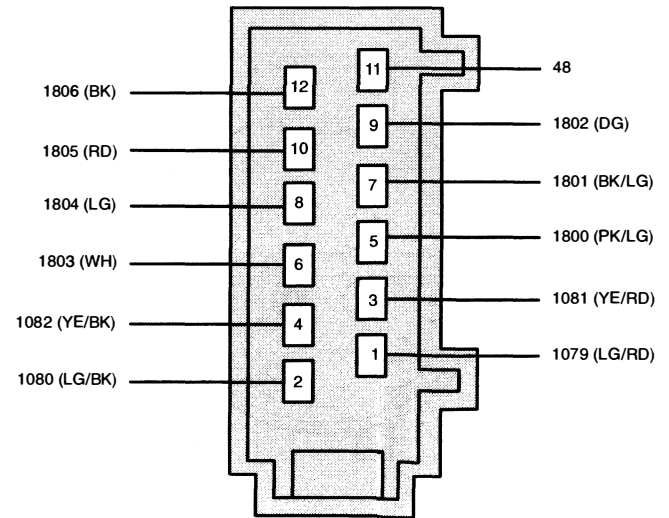
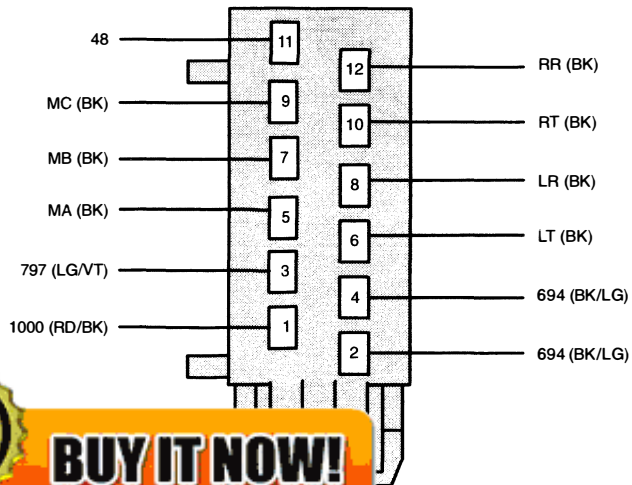

C379M

100% SATISFACTION GUARANTEED

BUY IT NOW!

Click Here To Order

IN-LINE CONNECTOR FACES 150-16

2001 F-150

* STYLE SIDE WITH REAR BUMPER

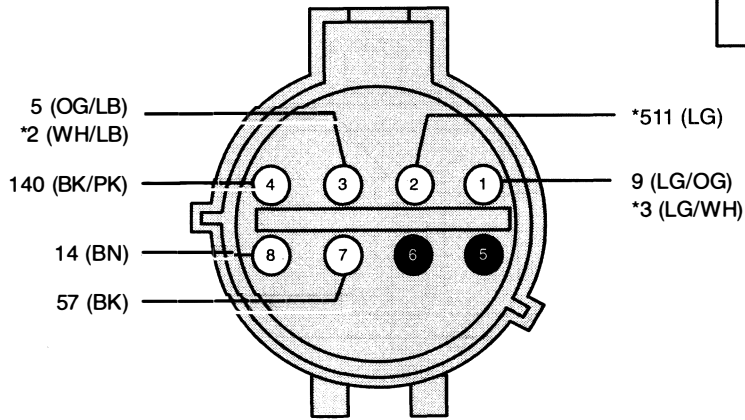

C403F

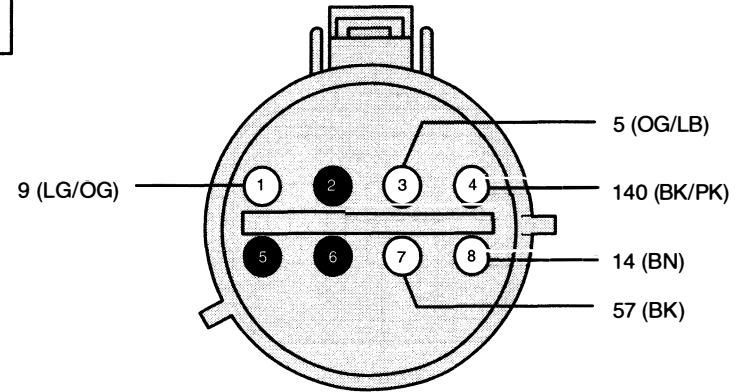

C403M

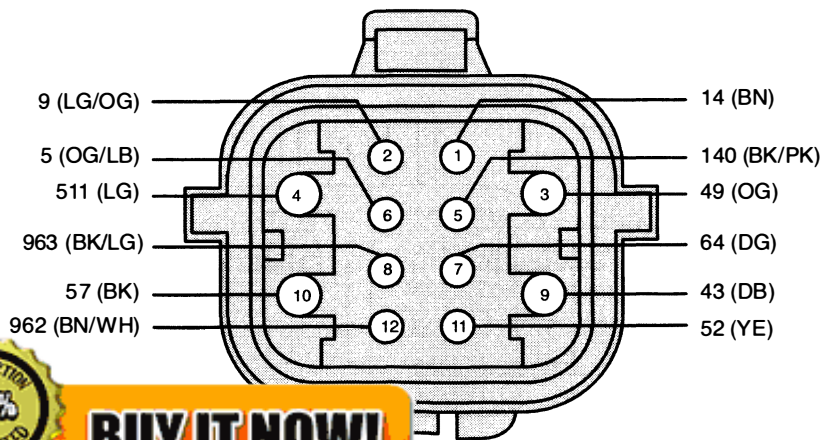

C411F

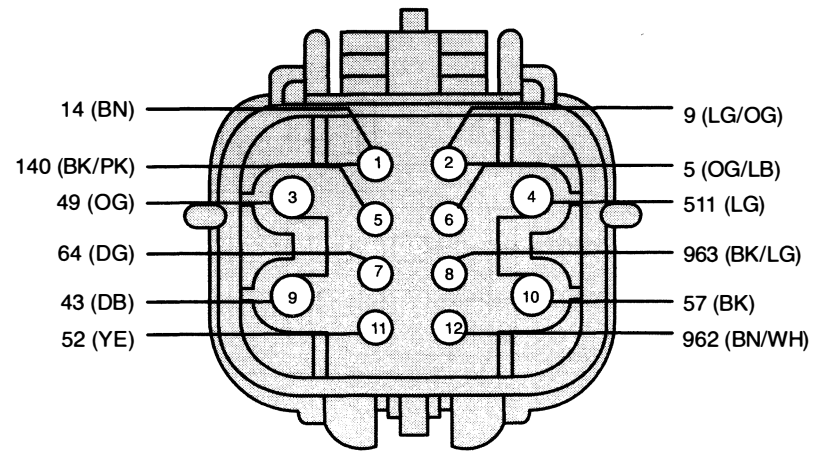

C411M

100% SATISFACTION GUARANTEED

BUY IT NOW!

Click Here To Order

150-17 IN-LINE CONNECTOR FACES

2001 F-150

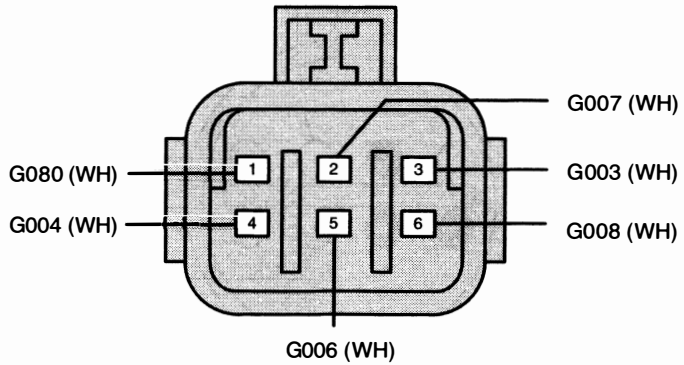

C4003F

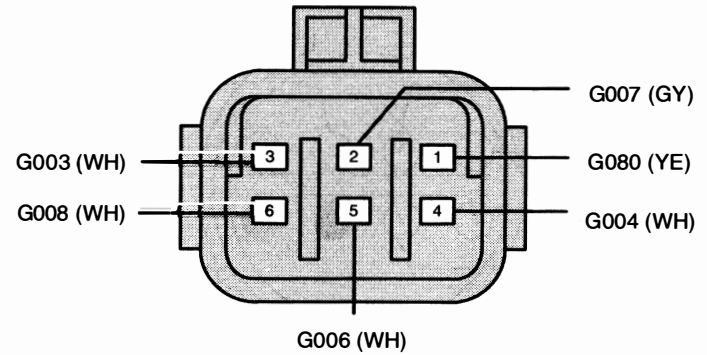

C4003M

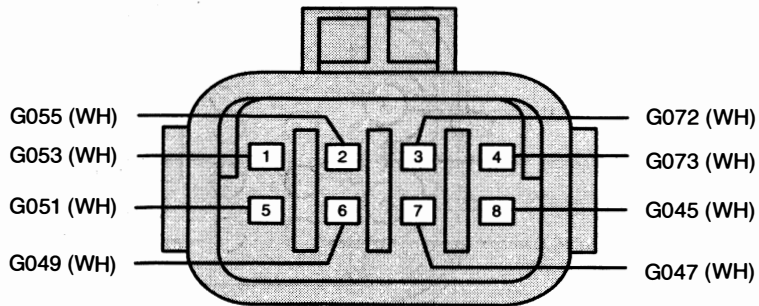

C4013F

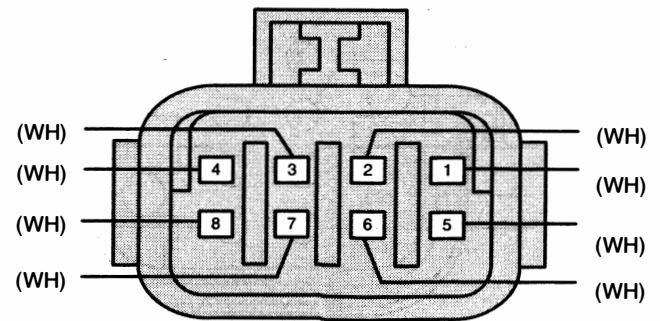

C4013M

100% SATISFACTION GUARANTEED

BUY IT NOW!

Click Here To Order

IN-LINE CONNECTOR FACES 150-18

2001 F-150

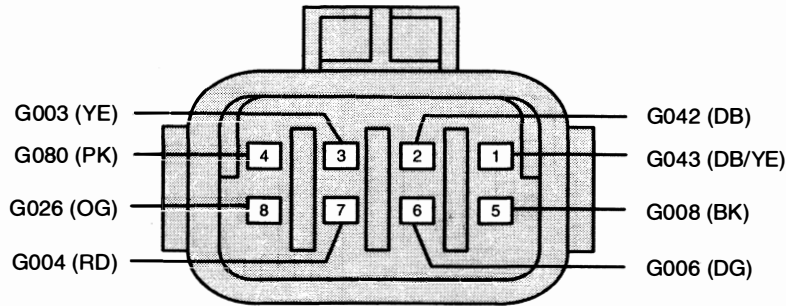

C4030F

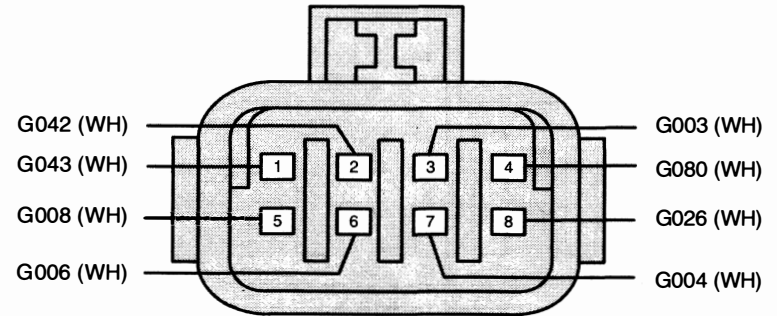

C4030M

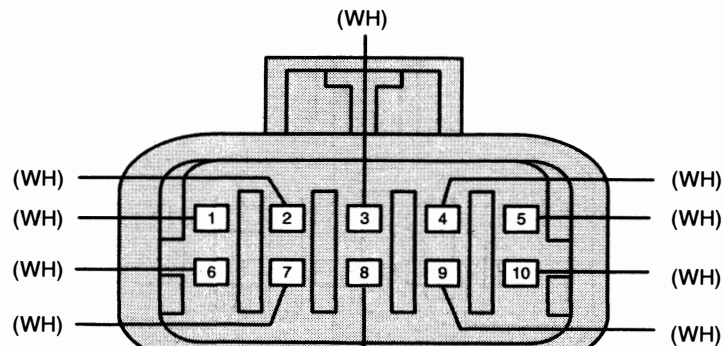

C4035F

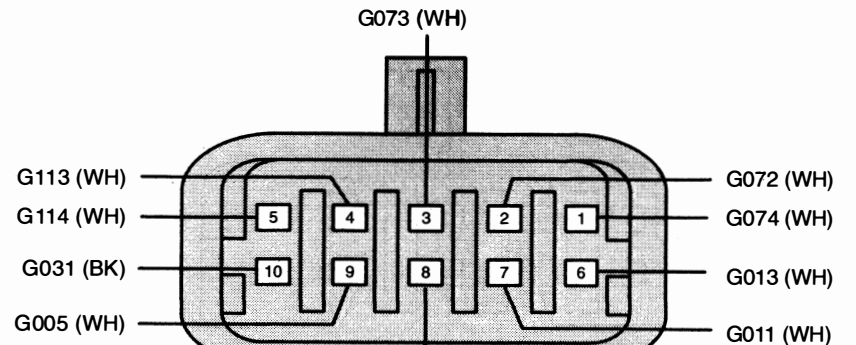

C4035M

100% SATISFACTION GUARANTEED

BUY IT NOW!

Click Here To Order

150-19 IN-LINE CONNECTOR FACES

2001 F-150

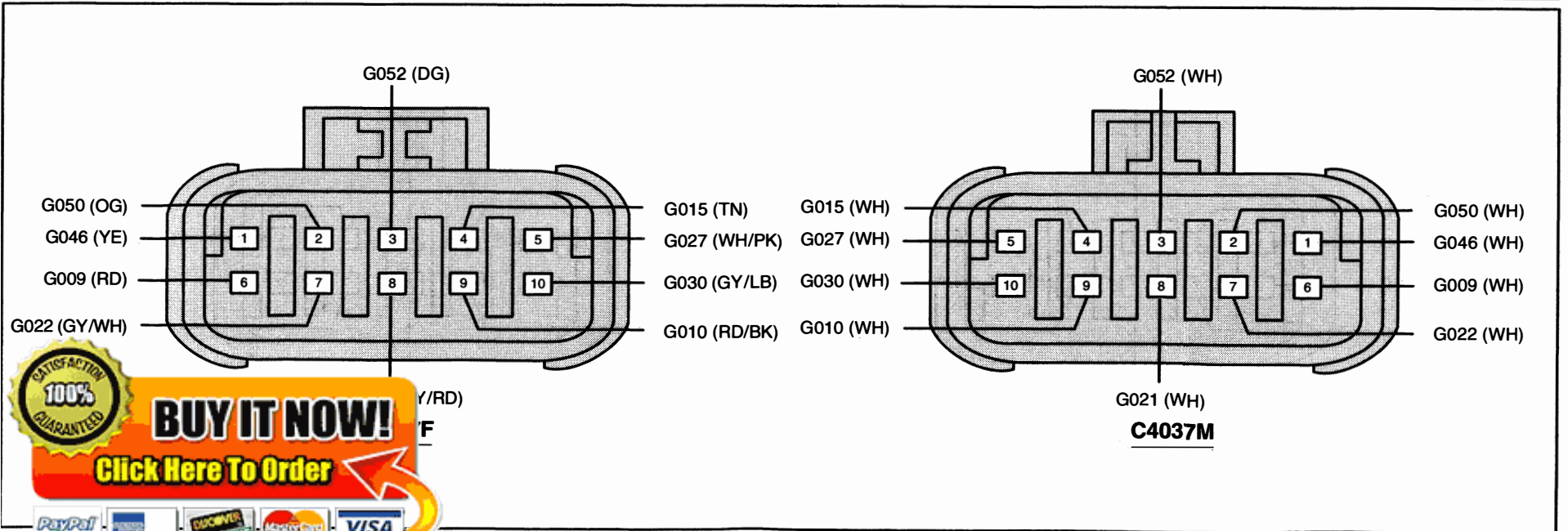
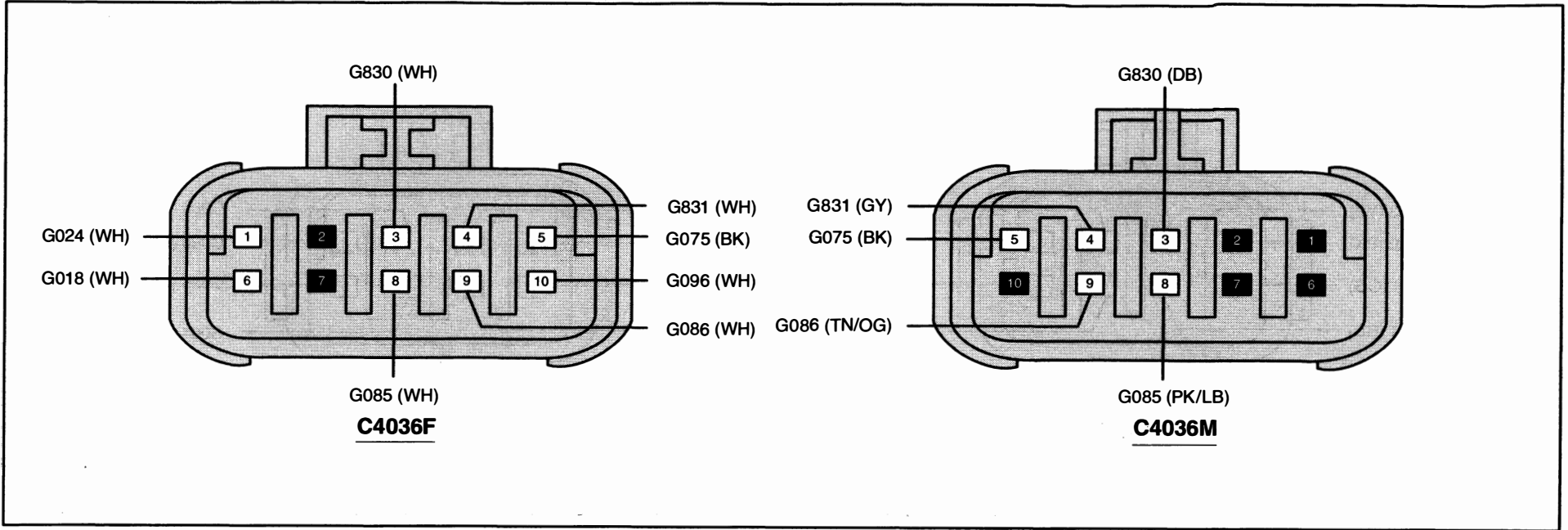

100% SATISFACTION GUARANTEED

BUY IT NOW!

Click Here To Order

IN-LINE CONNECTOR FACES 150-20

2001 F-150

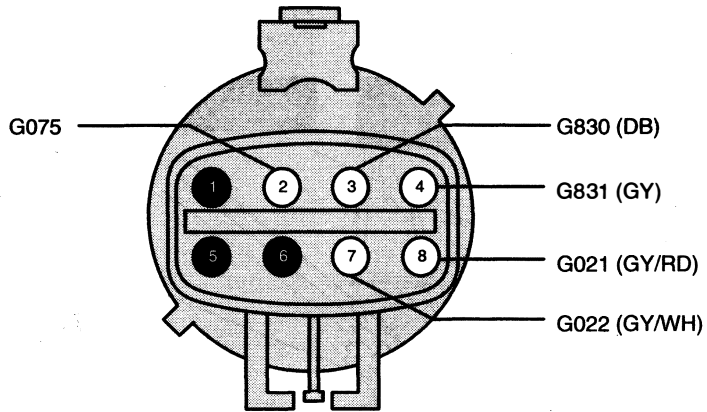

C4202F

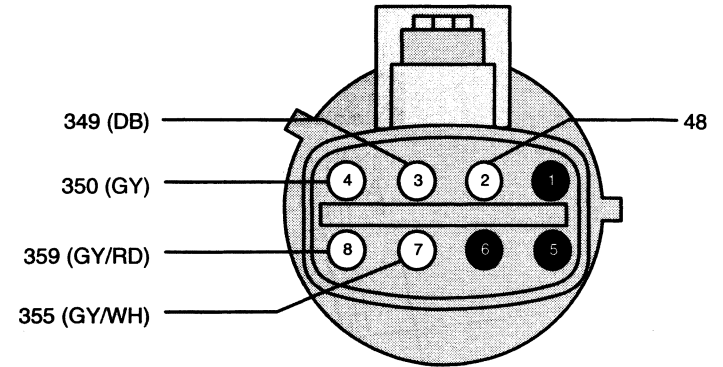

C4202M

100% SATISFACTION GUARANTEED

BUY IT NOW!

Click Here To Order

PayPal American Express Discover MasterCard VISA

151-1 COMPONENT LOCATION VIEWS

2001 F-150

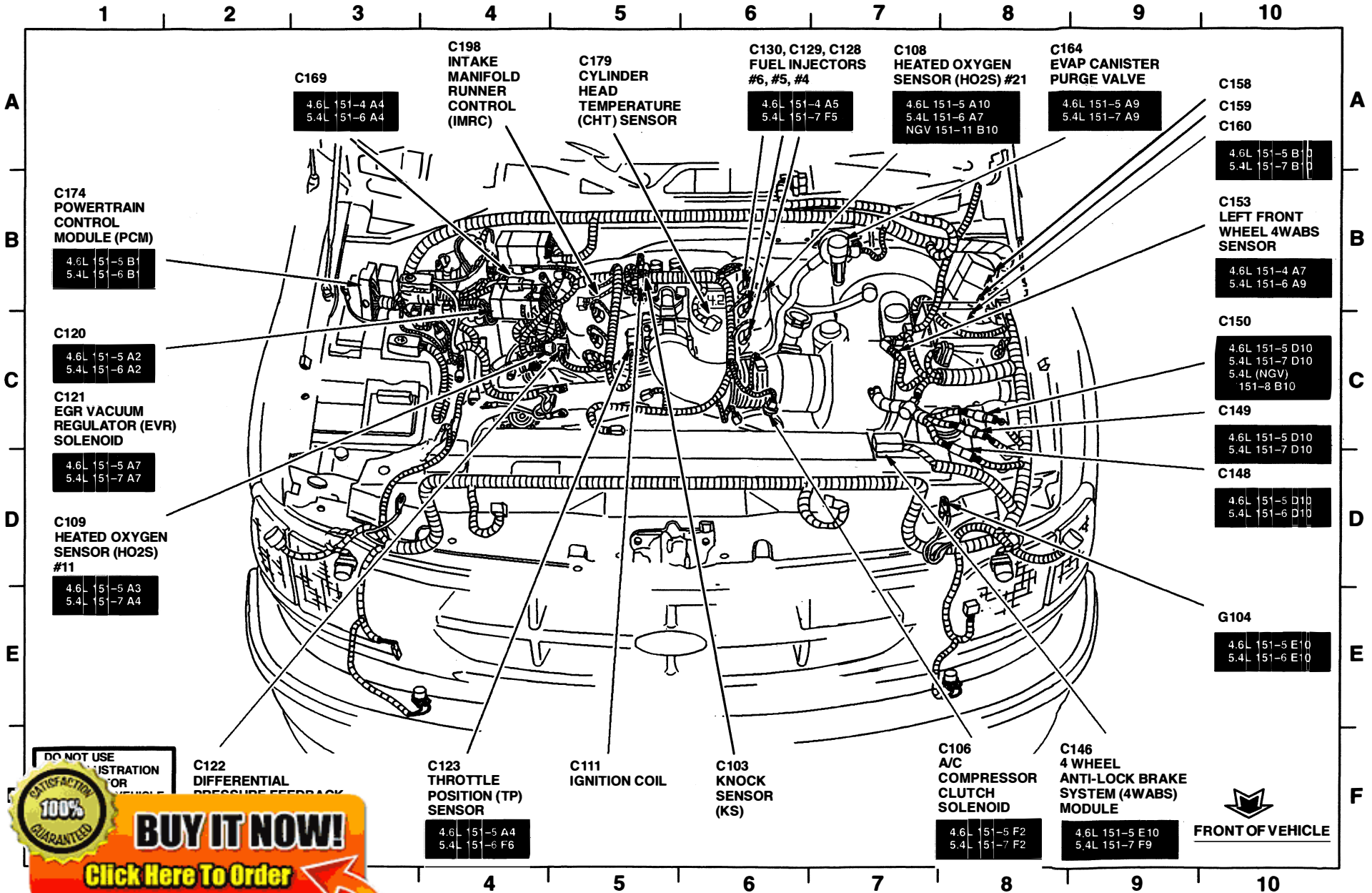

4.2L ENGINE (1 OF 3)

DO NOT USE FOR REGISTRATION OR VEHICLE IDENTIFICATION

100% GUARANTEED

BUY IT NOW!

[Click Here To Order](#)

COMPONENT LOCATION VIEWS 151-2

2001 F-150

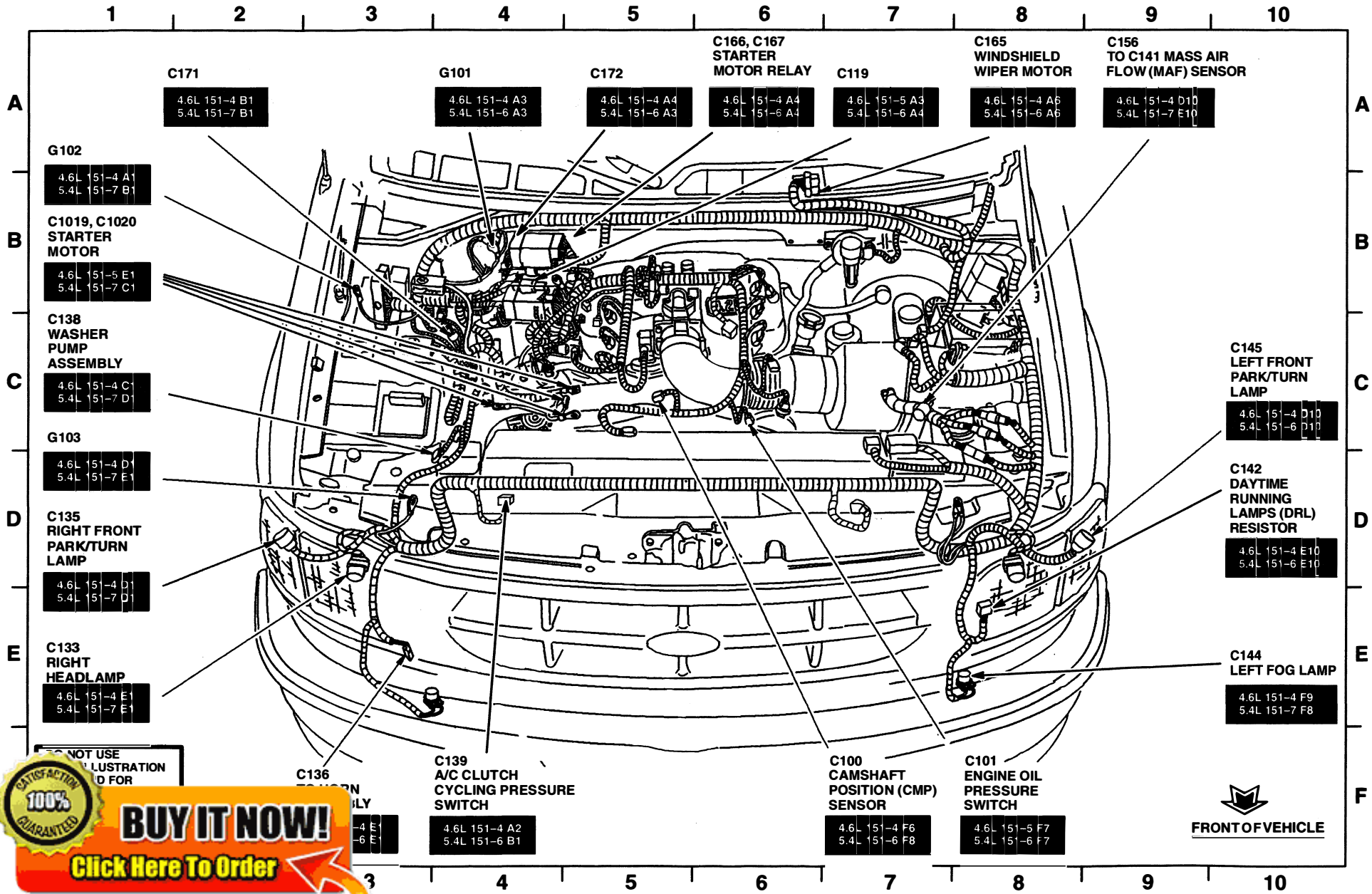

4.2L ENGINE (2 OF 3)

DO NOT USE THIS ILLUSTRATION FOR

100% SATISFACTION GUARANTEED

BUY IT NOW!

Click Here To Order



151-3 COMPONENT LOCATION VIEWS

2001 F-150

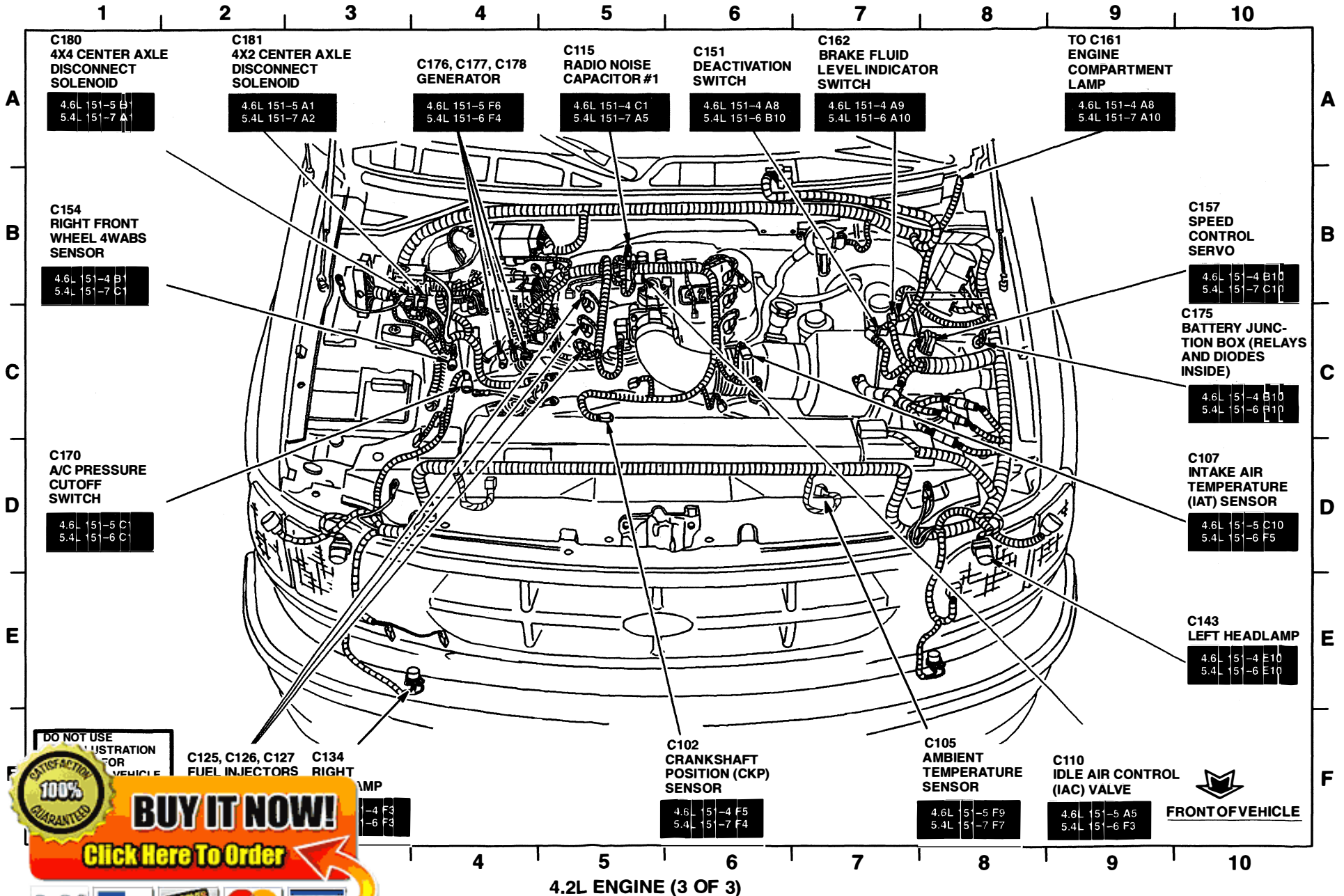

COMPONENT LOCATION VIEWS 151-4

2001 F-150

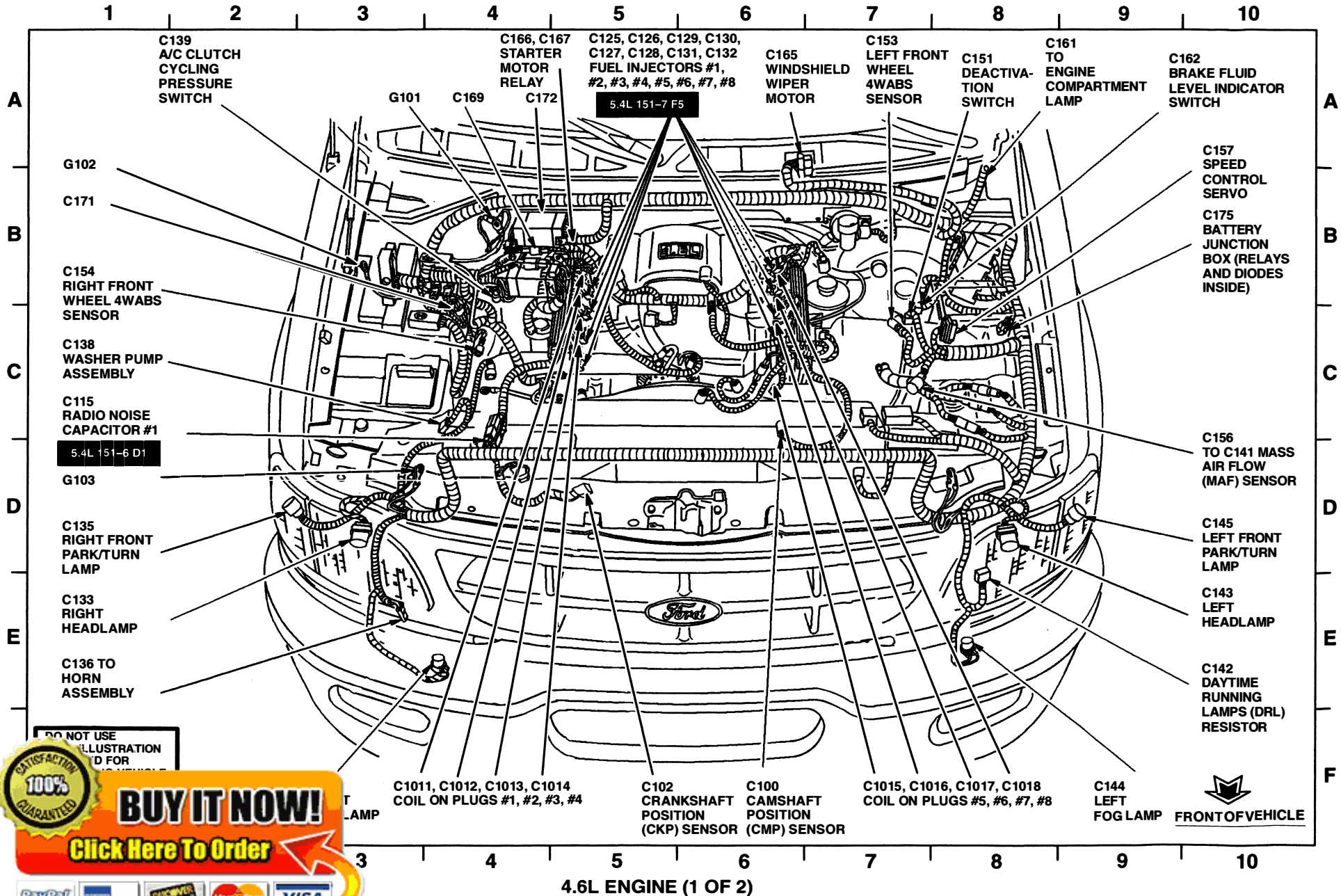

151-5 COMPONENT LOCATION VIEWS

2001 F-150

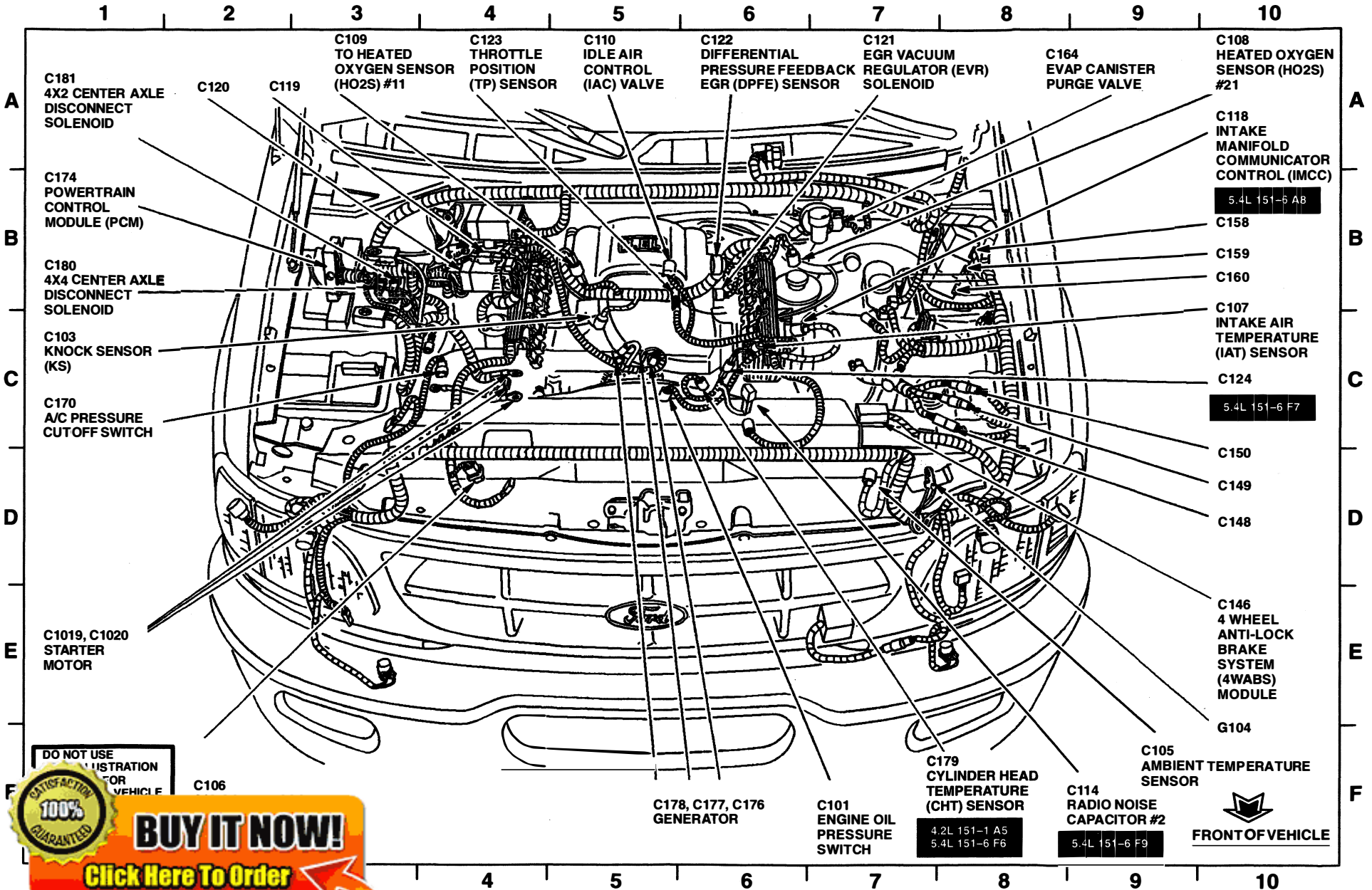

4.6L ENGINE (2 OF 2)

Ford Motor Company

**TECHNICAL
SUPPORT OPERATIONS**
Automotive Consumer Services Group

100% SATISFACTION GUARANTEED

BUY IT NOW!

Click Here To Order 

LITHO IN U.S.A.
PG-456



FCS-12263-01