

1 • 9 • 9 • 9

MUSTANG



100% MONEY BACK GUARANTEE

BUY IT NOW!

Click Here To Order

This DEMO contains only a few pages of the entire manual/product.

Not all Bookmarks work on the Demo, but they do on the full version.

Features:

- Searchable text
- Printable pages
- Bookmarked for easy navigation
- High Resolution images
- Zoom to see exact details
- Money back Guarantee
- Available on USB and eBook download



WIRING DIAGRAMS

Buy Now



License #84356800

Copyright © 2024, Forel Publishing Company, LLC, Woodbridge, Virginia

All Rights Reserved. No part of this book may be used or reproduced in any manner whatsoever without written permission of Forel Publishing Company, LLC. For information write to Forel Publishing Company, LLC, Woodbridge, VA 22192

1999 Mustang Wiring Diagrams

EAN: 978-1-60371-434-1

ISBN: 1-60371-434-0

Forel Publishing Company, LLC
Woodbridge, VA 22192
Email: sales@ForelPublishing.com
<https://www.ForelPublishing.com>



License #84356800

This publication contains material that is reproduced and distributed under a license from Ford Motor Company. No further reproduction or distribution of the Ford Motor Company material is allowed without the express written permission of Ford Motor Company.

Note from the Publisher

This product was created from the original Ford Motor Company's publication. Every effort has been made to use the original scanned images, however, due to the condition of the material; some pages have been modified to remove imperfections.

Disclaimer

Although every effort was made to ensure the accuracy of this book, no representations or warranties of any kind are made concerning the accuracy, completeness or suitability of the information, either expressed or implied. As a result, the information contained within this book should be used as general information only. The author and Forel Publishing Company, LLC shall have neither liability nor responsibility to any person or entity with respect to any loss or damage caused, or alleged to be caused, directly or indirectly by the information contained in this book. Further, the publisher and author are not engaged in rendering legal or other professional services. If legal, mechanical, electrical, or other expert assistance is required, the services of a competent professional should be sought.



WIRING DIAGRAMS FCS-12121-99

FORD CUSTOMER SERVICE DIVISION

Quality is Job 1

Ford Customer Service Division has continued with the existing format for the 1999 MUSTANG Wiring Diagrams. Our goal is to provide accurate and timely electrical service information.

1999 WIRING DIAGRAMS FEATURES

- Schematic pages contain **Component Location** references to full-view illustrations and **Component Descriptions** that describe the system function of a component.
- **"COMPONENT TESTING"** procedures (CELL 149) tell the user how to perform diagnostic tests on various circuits.
- **Connector End Views** are located at the end of individual cells and are shown for connectors with five or more cavities; for connectors with ten or more cavities, a circuit function chart is provided.
- **NOTES, CAUTIONS and WARNINGS** contain important safety information.
- Full view **"COMPONENT LOCATION VIEWS"** (CELL 151) help locate on-vehicle components.
- Circuit voltages are included on schematic pages to help simplify troubleshooting.
- **Cellular Pagination:** A specific section (or cell) in all Wiring Diagrams is numbered by cell and starts with page 1. For example: **"HOW TO USE THIS MANUAL"** is CELL 2 and begins with page 2-1.
- **"IN-LINE CONNECTOR FACES"** (CELL 150) are included for in-line connectors with six or more terminals, to aid in servicing electrical wiring.
- **"C"** numbers are assigned for all electrical connectors. **"C"** numbers are listed in the **"LOCATION INDEX"** (CELL 152).

"HARNES CAUSAL PART NUMBERS" (CELL 153) are included to aid in identifying

NUMBERS" contain a suffix to denote connector "gender" type

ORDERING INFORMATION

To obtain information about ordering additional copies of this publication or to order any other Ford or Lincoln/Mercury publications, call 1-800-782-4356. Available publications include workshop manuals, wiring diagrams, PC/ED Manuals and Owner Guides.

In addition, you can obtain a publications order form by writing to: Ford Publications, care of Helm Inc., P.O. Box 07150, Detroit, MI 48207.

All rights reserved. Reproduction by any means, electronic or mechanical, including photocopying, recording, or by any information storage and retrieval system or translation in whole or part is not permitted without written authorization from Ford Motor Company.

Copyright © 2000, Ford Motor Company



1-1 TABLE OF CONTENTS/INDEX

1999 MUSTANG

Table of Contents

How to Use This Manual	2-1
Grounds	10-1
Fuse Panel/Circuit Protection	11-1
Charging System	12-1
Power Distribution	13-1
Multiplex Communication Network ..	14-1
Starting System	20-1
Ignition System	21-1
Electronic Engine Controls (3.8L)	23-1
Electronic Engine Controls (4.6L 2V) ..	24-1
Electronic Engine Controls (4.6L 4V) ..	25-1
Transmission Controls	29-1
Speed Control	31-1
Cooling Fan	33-1
Shift Lock	37-1
Anti-lock Brake System (ABS)	42-1
Horn/Cigar Lighter	44-1
Air Bag Restraint System	46-1
Air Conditioner/Heater	54-1
Rear Window Defrost	56-1
Multifunction Electronic	
Control Modules	59-1
Instrument Cluster	60-1
Warning Chime	66-1
Instrument Illumination	71-1
Interval Wiper/Washer	81-1
Headlamps	85-1
Fog Lamps	86-1
Courtesy Lamps	89-1
Turn/Stop/Hazard Lamps	90-1
Exterior Lamps	92-1
Interior Lamps	93-1
Power Windows	97-1
Power Locks	100-1
Central Junction Box	102-1
Power Door Locks	101-1

Remote Keyless Entry	111-1
Anti-Theft	112-1
Luggage Compartment	
Lid Release	113-1
Power Seats	120-1
Power Lumbar Seats	122-1
Power Mirrors	124-1
Radio	130-1
Component Testing	149-1
In-Line Connector Faces	150-1
Component Location Views	151-1
Location Index	152-1
Harness Causal Part Number	153-1
Vehicle Repair Location Codes	160-1

Index

Air Bag Restraint System	46-1
Air Conditioner/Heater	54-1
Anti-Lock Brake System (ABS)	42-1
Anti-Theft	112-1
Battery Junction Box	
ABS 1	13-3
ABS 2	13-3
A/C PRESSURE	13-1
ALT	13-1
AUDIO	13-4
CONV TOP	13-3
DRL, FOG	13-4
FAN	13-1
FUEL PUMP	13-1
HD LPS	13-2
HORN	13-4
IGN SW	13-2
I/P	13-4
PARK LAMPS	13-2
PCM	13-2
POWER POINT	13-3

POWER SEAT	13-4
POWER WINDOWS	13-4
THERM	13-3
Central Junction Box	
Fuse 1	13-7
Fuse 4	85-1
Fuse 5	13-6
Fuse 6	13-5
Fuse 7	13-7
Fuse 10	85-1
Fuse 11	13-6
Fuse 13	13-7
Fuse 15	13-8
Fuse 17	13-6
Fuse 19	13-7
Fuse 20	13-5
Fuse 21	13-8
Fuse 23	13-6
Fuse 24	13-5
Fuse 25	13-8
Fuse 26	13-5
Fuse 27	13-9
Fuse 28	13-5
Fuse 29	13-6
Fuse 30	13-5
Fuse 31	13-8
Fuse 32	13-5
Fuse 33	13-9
Fuse 34	13-5
Fuse 35	90-1
Fuse 36	13-5
Fuse 37	13-13
Fuse 39	13-9
Fuse 41	90-1
Fuse 43	13-5
Charging System	12-1
Cigar Lighter	44-2

100% SATISFACTION GUARANTEED

BUY IT NOW!

Click Here To Order

PayPal Discover American Express MasterCard VISA

TABLE OF CONTENTS/INDEX 1-2

1999 MUSTANG

Component Location Views	151-1	G201	10-4	License	92-1
Component Testing		G203	10-5	Park	
Exterior Rear View Mirror	149-11	G204	10-6	Front	92-1
Ignition Switch	149-2	G205	10-5	Rear	92-1
Introduction	149-1	G300	10-9	Reversing	93-1
LF Seat Control Switch	149-10	G400	10-7	Side	
Main Light Switch	149-1	G402	56-1	Front	92-1
Master Window/Door Lock		Harness Causal Part Numbers	153-1	Rear	92-1
Control Switch	149-5, 149-6, 149-7, 149-8	Headlamps	85-1	Stop	90-3
Multifunction Switch	149-3, 149-4	Horn	44-1	Turn	
Right Window/Door Lock		Ignition Switch	13-5, 13-6	Front	90-2
Control Switch	149-9	Ignition System	21-1	Rear	90-3
Convertible Top	102-1	Indicators		Lamps (Interior)	
Courtesy Lamps	89-1	Air Bag	60-2	Courtesy	89-1
Daytime Running Lamps (DRL)	97-1	Anti-Lock	60-1	Instrument Illumination	71-1
Defrost (Rear Window)	56-1	Anti-Theft	60-2	Interior	89-2, 89-3
Door Locks (Power)	110-1	Brake	60-1	Luggage Compartment	89-4
Electronic Engine Control (3.8L)	23-1	Charge	60-2	Map	89-2, 89-3
Electronic Engine Control (4.6L 2V)	24-1	Fasten Belts	60-2	Vanity Mirror	89-2, 89-3
Electronic Engine Control (4.6L 4V)	25-1	High Beam	60-2	Location Index	152-1
Exterior Lamps	92-1	Left Turn	60-2	Luggage Compartment Lid Release ...	113-1
Fog Lamps	86-1	Low Coolant	60-2	Main Light Switch	13-13
Fuse Panel/Circuit Protection	11-1	Malfunction Indicator Lamp (MIL)		Mirrors (Power)	124-1
Gauges		(Check Engine)	60-2	Multiplex Communication Network	14-1
Fuel	60-1	Right Turn	60-2	Power Distribution	13-1
Oil Pressure	60-1	Transmission Control Indicator		Power Door Locks	110-1
Speedometer	60-2	Lamp (TCIL) (OD OFF)	60-2	Power Lumbar Seat	122-1
Tachometer	60-2	In-Line Connector Faces	150-1	Power Mirrors	124-1
Temperature	60-2	Instrument Cluster	60-1	Power Windows	100-1
Voltmeter	60-2	Instrument Illumination	71-1	Convertible	100-1
Electronic Module (GEM)	59-1	Interval Wiper/Washer	81-1	Coupe	100-3
Electronic Module (GEM)	59-1	Lamps (Exterior)		Radio	
Electronic Module (GEM)	59-1	Daytime Running	97-1	Premium Sound	130-1
Electronic Module (GEM)	59-1	Exterior	92-1	Super Sound	130-3
Electronic Module (GEM)	59-1	Fog	86-1	Rear Window Defrost	56-1
Electronic Module (GEM)	59-1	Hazard	90-1	Remote/Keyless Entry	111-1
Electronic Module (GEM)	59-1	Headlamps	85-1	Reversing Lamps	93-1



1-3 TABLE OF CONTENTS/INDEX

1999 MUSTANG

Seats (Lumbar)	122-1
Shift Lock	37-1
Speed Control	31-1
Starting System	20-1
Turn/Stop/Hazard Lamps	90-1
Vehicle Repair Location Codes	160-1
Warning Chime	66-1
Windows (Power)	100-1
Wiper/Washer (Interval)	81-1

IMPORTANT SAFETY NOTICE

Appropriate service methods and proper repair procedures are essential for the safe, reliable operation of all motor vehicles, as well as the personal safety of the individual doing the work. This Manual provides general directions for accomplishing service and repair work with tested, effective techniques. Following them will help assure reliability.

There are numerous variations in procedures, techniques, tools, and parts for servicing vehicles, as well as in the skill of the individual doing the work. This Manual cannot possibly anticipate all such variations and provide advice or cautions as to each. Accordingly, anyone who departs from the instructions provided in this Manual must first establish that the choice of methods, tools, or parts does not compromise personal safety or vehicle integrity.



BUY IT NOW!

Click Here To Order



NOTES 1-4

1999 MUSTANG

BUY IT NOW!
Click Here To Order

100% SATISFACTION GUARANTEE

PayPal
American Express
Discover
MasterCard
VISA

2-1 HOW TO USE THIS MANUAL

1999 MUSTANG

The purpose of this manual is to show electrical circuits in a clear and simple fashion to make troubleshooting easier. **NOTES, CAUTIONS** and **WARNINGS** contain important information.

- **NOTES** describe how switches and other components operate to help complete a particular procedure.
- **CAUTIONS** provide information that could prevent making an error that may damage the vehicle.
- **WARNINGS** provide information to prevent personal injury.

The **WARNINGS** list on page 2-2 contains general warnings to follow when servicing a vehicle.

Components that work together are shown together. All electrical components used in a specific system are shown on one diagram. The circuit breaker or fuse is shown at the top of the page. All wires, connectors, components and splices are shown in the flow of current to ground at the bottom of the page. If a component is used in several different systems, it is shown in several places. For example, the Main Light Switch is electrically a part of many systems and is repeated on many pages.

In some cases, a component may seem (by its name) to belong to a system where it has no electrical connection. For example, Radio Illumination is electrically part of Instrument Illumination, but because it has no electrical connection to the Radio system, it is not shown on the Radio diagram.

Schematic pages contain references to full-view illustrations and description notes for various components that blocks and connectors and on page describe the

Schematic pages contain circuit voltages to help simplify troubleshooting hints. 12V is used to imply battery voltage on a component connector terminal, and 0V is used to show that there should be continuity to ground on that particular terminal. Conditional voltages such as "12V with the ignition switch in RUN" will also be provided. Troubleshooting hints that can't be simplified with circuit voltages will be shown at the end of each cell.

Component connector face information specific to a certain cell is found at the end of that cell. A Connector Face Reference List is provided to locate connector faces that are shown in different cells. Component connectors with five or more terminals are illustrated and are accompanied by a pinout chart that lists the function of all circuitry associated with that component.

"GROUNDS" (Cell 10) contains ground circuitry shown in complete detail. This information is useful for checking interconnections of the ground circuits of different systems.

"POWER DISTRIBUTION" (Cell 13) contains power distribution circuitry shown in complete detail. This section displays how the various fuses are powered and, in turn, how each system is powered.

"COMPONENT TESTING" (Cell 149) contains testing procedures for various switches. This information includes schematics, component terminal locations and step-by-step procedures.

"IN-LINE CONNECTOR FACES" (Cell 150) contains illustrations of all the in-line connectors that have 6 or more terminals. The terminals have pin numbers assigned to them.

"COMPONENT LOCATION VIEWS" (Cell 151) contains full-view illustrations which show the location of all components and connectors in the vehicle.

The **"LOCATION INDEX"** (Cell 152) provides the base part numbers, locations, connector face references and illustration references for all components, connectors, splices and grounds.

HELPFUL REMINDERS

Before using the wiring diagrams for troubleshooting, refer to these HELPFUL REMINDERS:

1. The abbreviation T/O, for take out, used in the Location Index (Cell 152), refers to the point at which a group of wires branch off the harness trunk. Refer to the wiring harness illustration.

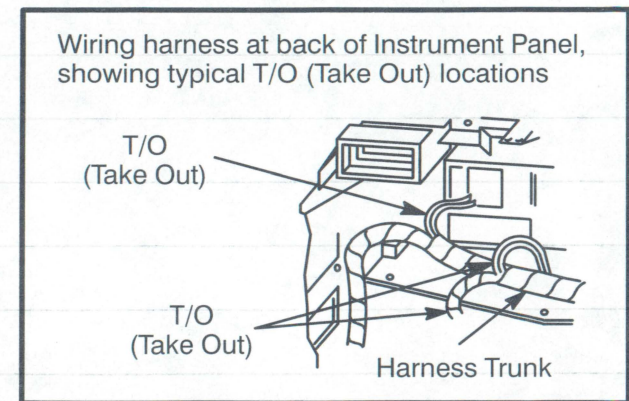

2. If a connector serves the same purpose in two separate versions (e.g., Automatic/Manual), but is physically different, *two* connector numbers are used. However, if a connector serves the same purpose in two separate versions (e.g., Automatic/Manual) and is physically the same, but the wire colors are different, only *one* connector number is used. If the same physical connector is used more than once, then more than *one* connector number is used.

100% SATISFACTION GUARANTEED

BUY IT NOW!

Click Here To Order

PayPal American Express Discover Novus MasterCard VISA

3. Wiring schematics provide a picture of how and under what conditions the circuit is powered, of the current path to circuit components, and of how a circuit is grounded. Each circuit component is named (underlined titles). Wire and connector colors are listed as follows (standard Ford color abbreviations are used):

COLOR ABBREVIATIONS

BU	Blue	NA	Natural
BK	Black	OG	Orange
BN	Brown	PK	Pink
DB	Dark Blue	VT	Purple
DG	Dark Green	RD	Red
GN	Green	SR	Silver
GY	Gray	TN	Tan
LB	Light Blue	WH	White
LG	Light Green	YE	Yellow

Note: Whenever a wire is labeled with two colors, the first color listed is the basic color of the wire, and the second color listed is the stripe marking of the wire.

4. When reporting Vehicle Repair Location Codes to Ford Customer Service Division, refer to Cell 160 (beginning on page 160-1). Note: Do *not* use the illustrations in Cell 151 (beginning on page 151-1) for reporting Vehicle Repair Location Codes.

5. WARNINGS

- Always wear safety glasses for eye protection.
- Use safety stands whenever a procedure requires being under a vehicle.
- Be sure that the **Ignition Switch** is always in the OFF position, unless otherwise required by the procedure.
- Set the parking brake when working on any vehicle. An automatic transmission should be in PARK. A manual transmission should be in NEUTRAL.
- Operate the engine only in a well-ventilated area to avoid danger of carbon monoxide.
- Keep away from moving parts, especially the fan and belts, when the engine is running.
- To prevent serious burns, avoid contact with hot metal parts such as the radiator, exhaust manifold, tail pipe, catalytic converter and muffler.
- Do not allow flame or sparks near the battery. Gases are always present in and around the battery cell. An explosion could occur.
- Do not smoke when working on a vehicle.
- To avoid injury, always remove rings, watches, loose hanging jewelry and avoid wearing loose clothing.

HOW TO FIND ELECTRICAL CONCERNS

TROUBLESHOOTING STEPS

These six steps present an orderly method of troubleshooting.

Step 1. Verify the concern.

- Operate the complete system to check the accuracy and completeness of the customer's complaint.

Step 2. Narrow the concern.

- Using the wiring diagrams, narrow down the possible causes and locations of the concern to pinpoint the exact cause.
- Read the description notes at the components and study the wiring schematic. You should then know enough about the circuit operation to determine where to check for the trouble. Further information can be found by referring to the Service Manual pages listed in the box at the top of the page.

Step 3. Test the suspected cause.

- Use electrical test procedures to find the specific cause of the symptoms.
- The component location reference bars and the pictures will help you find components. The Location Index (at the end of the manual) gives component location information for connectors, diodes, resistors, splices and grounds.

Step 4. Verify the cause.

- Confirm that you have found the correct cause by connecting jumper wires and/or temporarily installing a known good component and operating the circuit.

Step 5. Make the repair.

- Repair or replace the inoperative component.

Step 6. Verify the repair.

- Operate the system as in Step 1 and check that your repair has removed all symptoms without creating any new symptoms.



2-3 HOW TO USE THIS MANUAL

1999 MUSTANG

Some engine circuits may need special test equipment and special procedures. See the *Workshop Manual* and other service books for details. You will find the circuits in this manual to be helpful with those special test procedures.

TROUBLESHOOTING TOOLS

JUMPER WIRE

This is a test lead used to connect two points of a circuit. A Jumper Wire can bypass an open to complete a circuit.

WARNING

Never use a jumper wire across loads (motors, etc.) connected between hot and ground. This direct battery short may cause injury or fire.

VOLTMETER

A DC Voltmeter measures circuit voltage. Connect negative (- or black) lead to ground, and positive (+ or red) lead to voltage measuring point.

OHMMETER

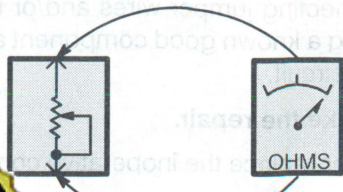

BUY IT NOW!

Click Here To Order



An Ohmmeter shows the resistance between two connected points (Figure 1).

TEST LAMP

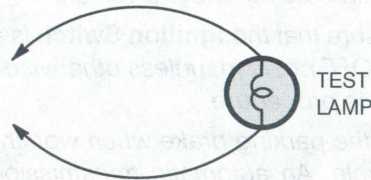

Figure 2 – Test Lamp

A Test Light is a 12-volt bulb with two test leads (Figure 2).

Uses: Voltage Check, Short Check.

SELF-POWERED TEST LAMP

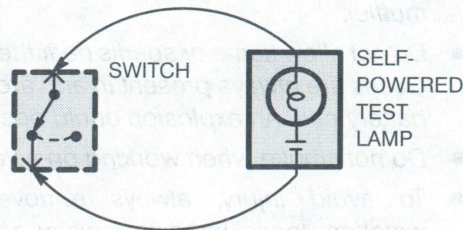

Figure 3 – Continuity Check

The Self-Powered Test Lamp is a bulb, battery and set of test leads wired in series (Figure 3). When connected to two points of a continuous circuit, the bulb glows.

Uses: Continuity Check, Ground Check.

CAUTION

When using a self-powered test lamp or ohmmeter, be sure power is off in circuit during testing. Hot circuits can cause equipment damage and false readings.

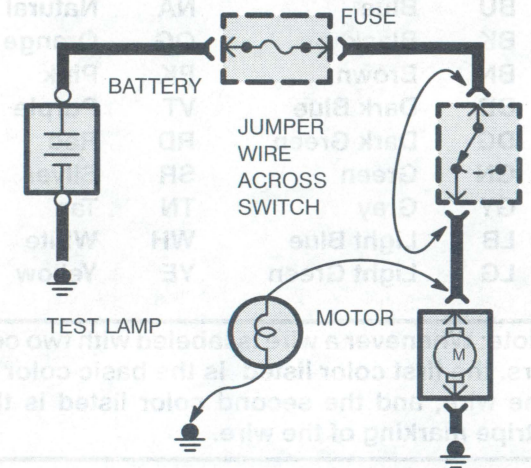

Figure 4 – Switch Circuit Check and Voltage Check

In an inoperative circuit with a switch in series with the load, jumper the terminals of the switch to power the load. If jumpering the terminals powers the circuit, the switch is inoperative (Figure 4).

CONTINUITY CHECK (Locating open circuits)

Connect one lead of Self-Powered Test Lamp or Ohmmeter to each end of circuit (Figure 3). Lamp will glow if circuit is closed. Switches and fuses can be checked in the same way.

VOLTAGE CHECK

Connect one lead of test lamp to a known good ground or the negative (-) battery terminal. Test for voltage by touching the other lead to the test point. Bulb goes on when the test point has voltage (Figure 4).

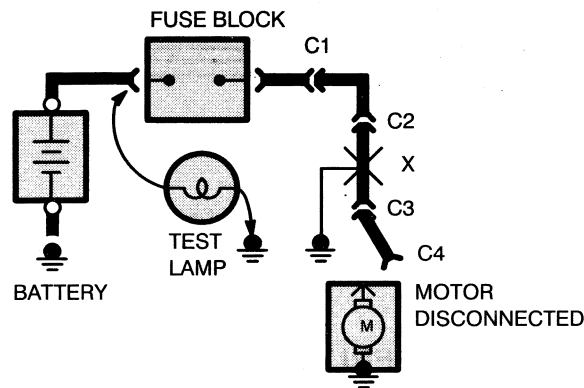

Figure 5 – Short Check

A fuse that repeatedly blows is usually caused by a short to ground. It's important to be able to locate such a short quickly (Figure 5).

1. Turn off everything powered through the fuse.
2. Disconnect other loads powered through the fuse:
 - Motors: disconnect motor connector (Connector C4 in Figure 5).
 - Lights: remove bulbs.

4. Connect one Test Lamp lead to hot end of blown fuse. Connect other lead to ground. Bulb should glow, showing power to fuse. *(This step is just a check to be sure you have power to the circuit.)*
5. Disconnect the test lamp lead that is connected to ground, and reconnect it to the load side of the fuse at the connector of the disconnected component. (In Figure 5, connect the test lamp lead to connector C4.)
 - If the Test Lamp is off, the short is in the disconnected component.
 - If the Test Lamp goes on, the short is in the wiring. You must find the short by disconnecting the circuit connectors, one at a time, until the Test Lamp goes out. For example, in Figure 5 with a ground at X, the bulb goes out when C1 or C2 is disconnected, but not after disconnecting C3. This means the short is between C2 and C3.

Turn on power to the circuit. Perform a Voltage Check between the suspected inoperative ground and the frame. Any indicated voltage means that the ground is inoperative (Figure 6).

Turn off power to the circuit. Connect one lead of a Self-Powered Test Lamp or Ohmmeter to the wire in question and the other lead to a known ground. If the bulb glows, the circuit ground is OK (Figure 6).

The circuit schematics in this manual make it easy to identify common points in circuits. This knowledge can help narrow the concern to a specific area. For example, if several circuits fail at the same time, check for a common power or ground connection (see *Power Distribution* or *Grounds*). If part of a circuit fails, check the connections between the part that works and the part that doesn't work.

For example, if the lo beam headlamps work, but the high beams and the indicator lamp don't work, then power and ground paths must be good. Since the dimmer switch is the component that switches this power to the high beam lights and indicator, it is most likely the cause of failure.

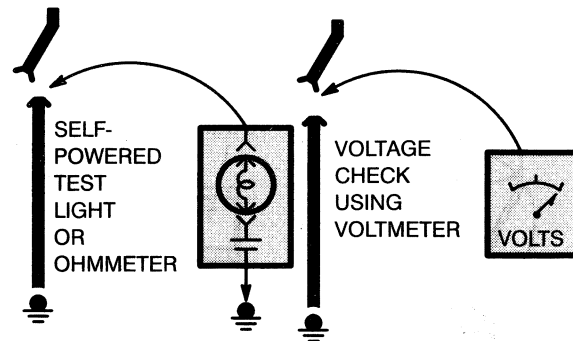

Figure 6 – Ground Check

Location Switch to RUN (if necessary) to

100% SATISFACTION GUARANTEED

BUY IT NOW!

Click Here To Order

PayPal American Express Discover MasterCard VISA

2-5 HOW TO USE THIS MANUAL

1999 MUSTANG

TROUBLESHOOTING WIRING HARNESS AND CONNECTOR HIDDEN CONCERNS

The following illustrations are known examples of wiring harness, splices and connectors that will create intermittent electrical concerns. The concerns are hidden and can only be discovered by a physical evaluation as shown in each illustration.

NOTE: Several components, such as the PCM, utilize gold plated terminals in their connections to the wiring harness. If those terminals need to be replaced, they must be replaced with a gold plated terminal.

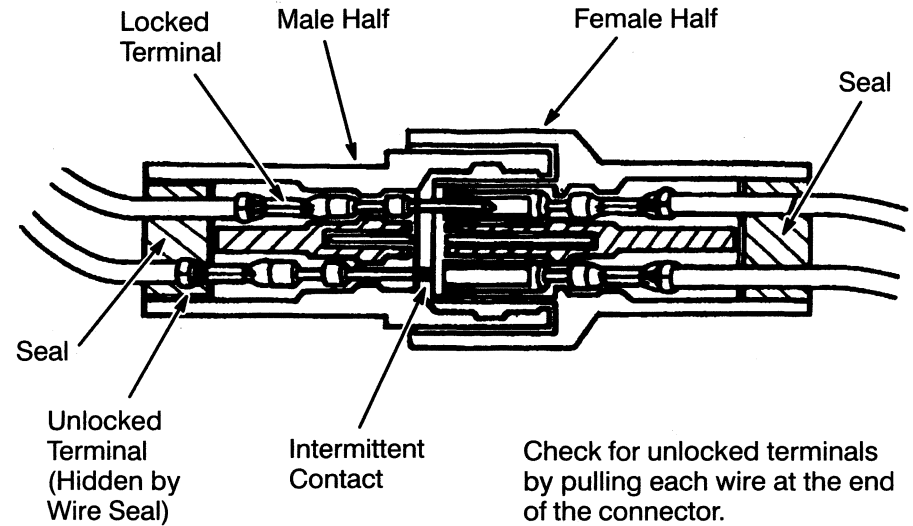

TERMINAL NOT PROPERLY SEATED

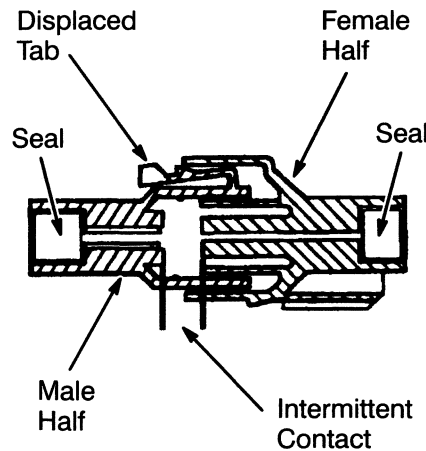
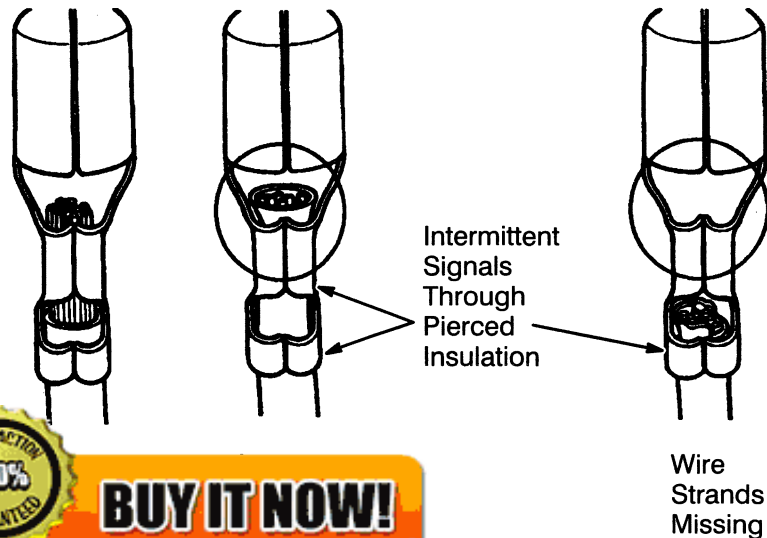

Lock may be displaced into an unlocked position; pull on the connector to verify the lock.

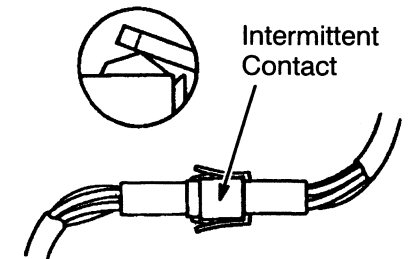

Type A

Type B

PARTIALLY MATED CONNECTORS

100% SATISFACTION GUARANTEED

BUY IT NOW!

Click Here To Order

ON STRIPPING

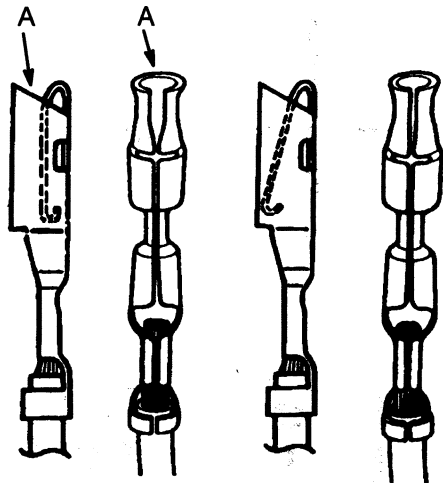

Enlarged

Normal

Any probe entering the terminal may enlarge the contact spring opening creating an intermittent signal. Insert the correct mating terminal (Location A) from the service kit and feel for a loose fit.

DEFORMED (ENLARGED) FEMALE TERMINALS

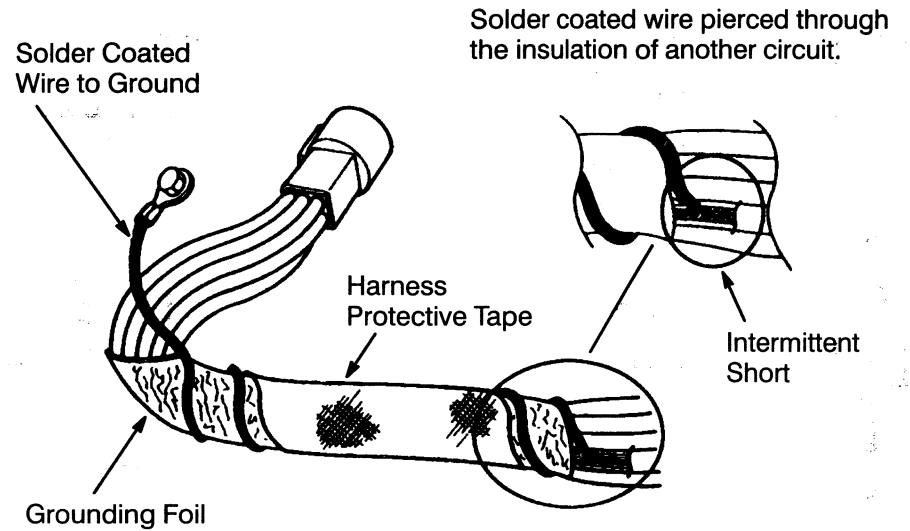

ELECTRICAL SHORT INSIDE THE HARNESS

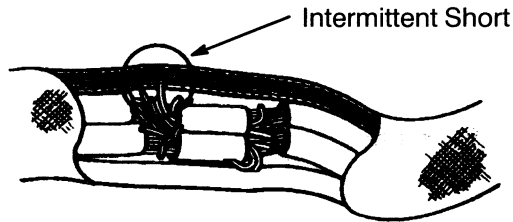

Splice Tape Removed

Operate the system and flex the harness at splice location noted in Section 152.

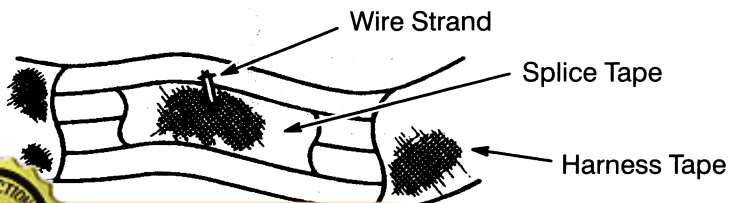

Wire Strand

Splice Tape

Harness Tape

WITHIN THE HARNESS

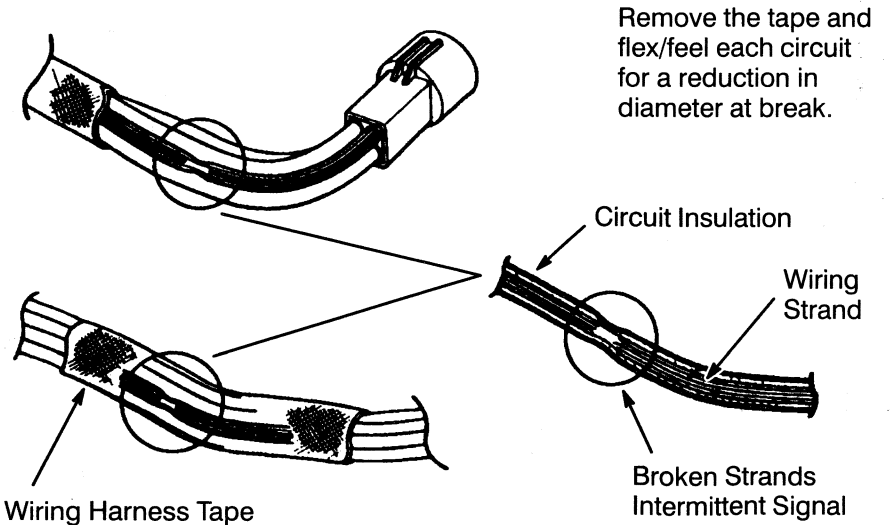

Wiring Harness Tape

Circuit Insulation

Wiring Strand

Broken Strands Intermittent Signal

BROKEN WIRE STRANDS IN HARNESS

100% SATISFACTION GUARANTEED

BUY IT NOW!

Click Here To Order

2-7 HOW TO USE THIS MANUAL

1999 MUSTANG

ELECTRICAL SYMBOLS

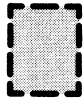

DASHED COMPONENT BOX
ONLY PART OF THE COMPONENT IS SHOWN ON THE PAGE; THE COMPONENT IS SHOWN COMPLETE IN ANOTHER LOCATION

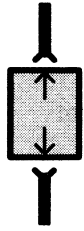

COMPONENT WITH CONNECTORS

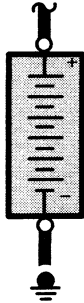

BATTERY

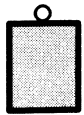

SCREW TERMINAL ON COMPONENT

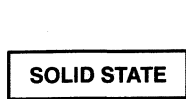

SEALED ELECTRONIC COMPONENT
ANY CIRCUITRY SHOWN INSIDE THE BOX IS A FUNCTIONAL

SOLID STATE

100% SATISFACTION GUARANTEED

BUY IT NOW!

Click Here To Order

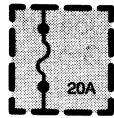

FUSE
CURRENT RATING

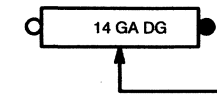

FUSIBLE LINK
WIRE SIZE AND COLOR

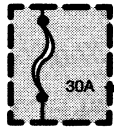

MAXI-FUSE OR FUSIBLE LINK CARTRIDGE
CURRENT RATING

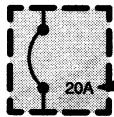

CIRCUIT BREAKER
CURRENT RATING

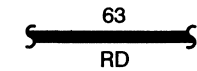

SOLID WIRES

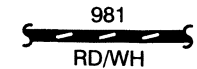

STRIPED WIRES

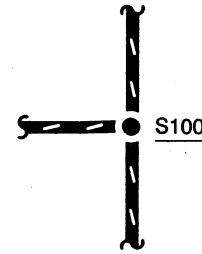

SPLICE OR CRIMP TERMINAL

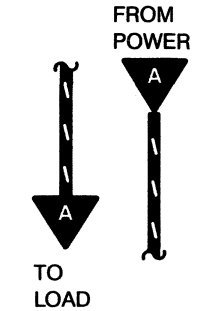

"CUT" WIRES REFERENCED BETWEEN PAGES
ARROWS SHOW CURRENT FLOW FROM POWER TO GROUND



"REFERENCE" WIRES
COMPLETE WIRING SHOWN ON ANOTHER PAGE

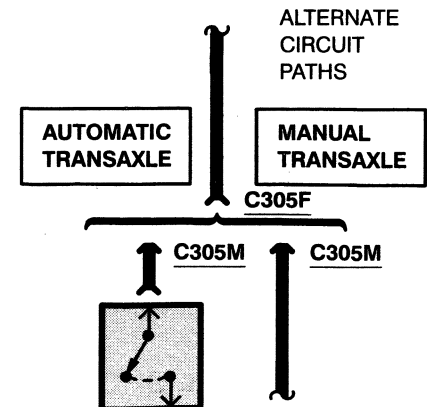

ELECTRICAL SYMBOLS

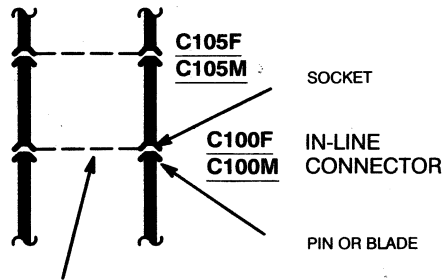

SINGLE DASHED LINE INDICATES THAT WIRE ON LEFT ALSO PASSES THROUGH THE SAME CONNECTOR

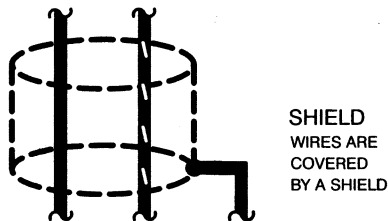
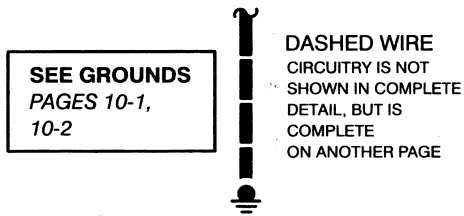

MOTOR



HEATING
ELEMENT



THERMISTOR



RHEOSTAT
OR
POTENTIOMETER



SOLENOID

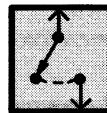

SWITCH

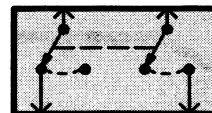

GANGED
SWITCHES
CONTACTS MOVE
AT THE SAME TIME

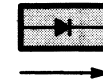

DIODES
CURRENT FLOWS
IN DIRECTION OF
ARROW ONLY

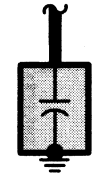

CAPACITOR



TRANSISTOR

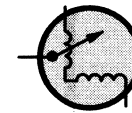

GAUGE



LIGHT
EMITTING
DIODE
(LED)



LIGHT
BULB

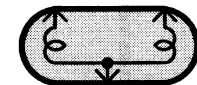

DUAL FILAMENT
LIGHT BULB

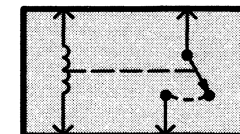

RELAY
CONTACTS
CHANGE POSITION
WITH CURRENT
THROUGH COIL

100% SATISFACTION GUARANTEED

BUY IT NOW!

Click Here To Order

10-1 GROUNDS

1999 MUSTANG

All wires are 1205 (BK) unless otherwise noted.

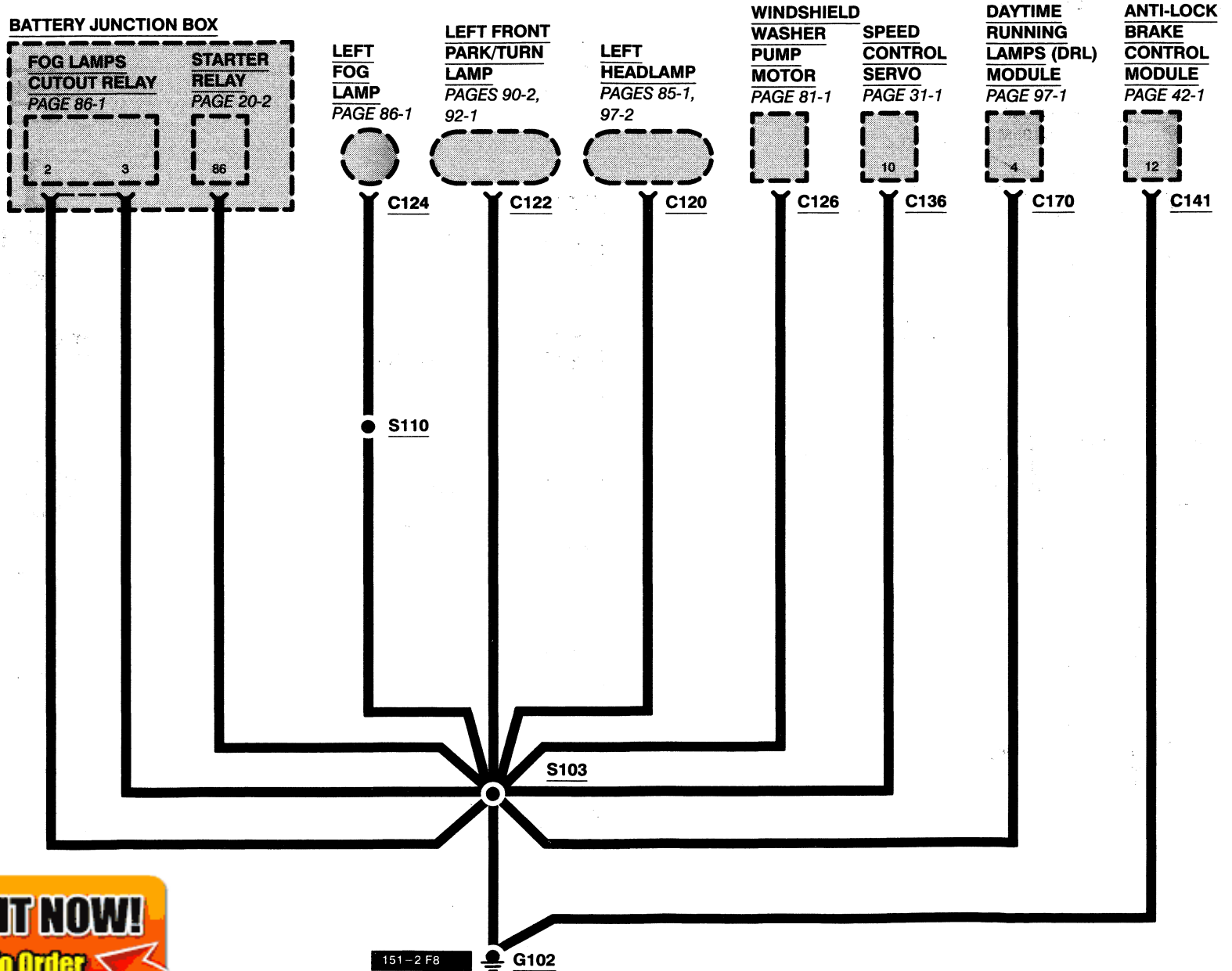

100% SATISFACTION GUARANTEED

BUY IT NOW!

[Click Here To Order](#)

PayPal | American Express | Discover | MasterCard | VISA

All wires are 1205 (BK) unless otherwise noted.

* 3.8L
** 4.6L

MASS AIR FLOW (MAF) SENSOR
PAGES 23-1, 24-1, 25-1

POWERTRAIN CONTROL MODULE (PCM)
PAGES 23-1, 24-1, 25-1

CONSTANT CONTROL RELAY MODULE (CCRM)
PAGES 23-9, 24-9, 25-9

DATA LINK CONNECTOR (DLC)
PAGE 14-1

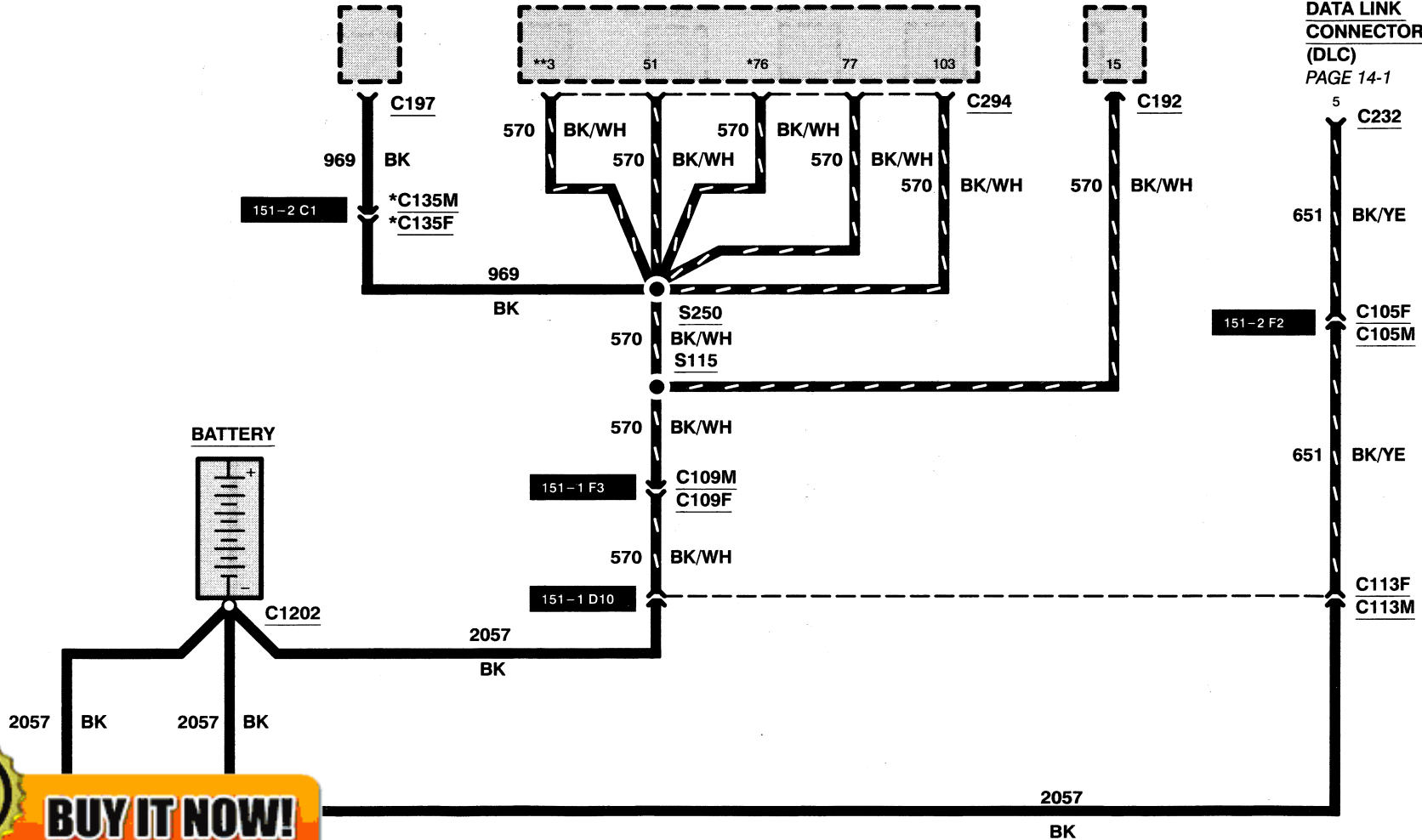

100% SATISFACTION GUARANTEED

BUY IT NOW!

Click Here To Order

PayPal | American Express | Discover | MasterCard | VISA

10-3 GROUNDS

1999 MUSTANG

All wires are 1205 (BK) unless otherwise noted.

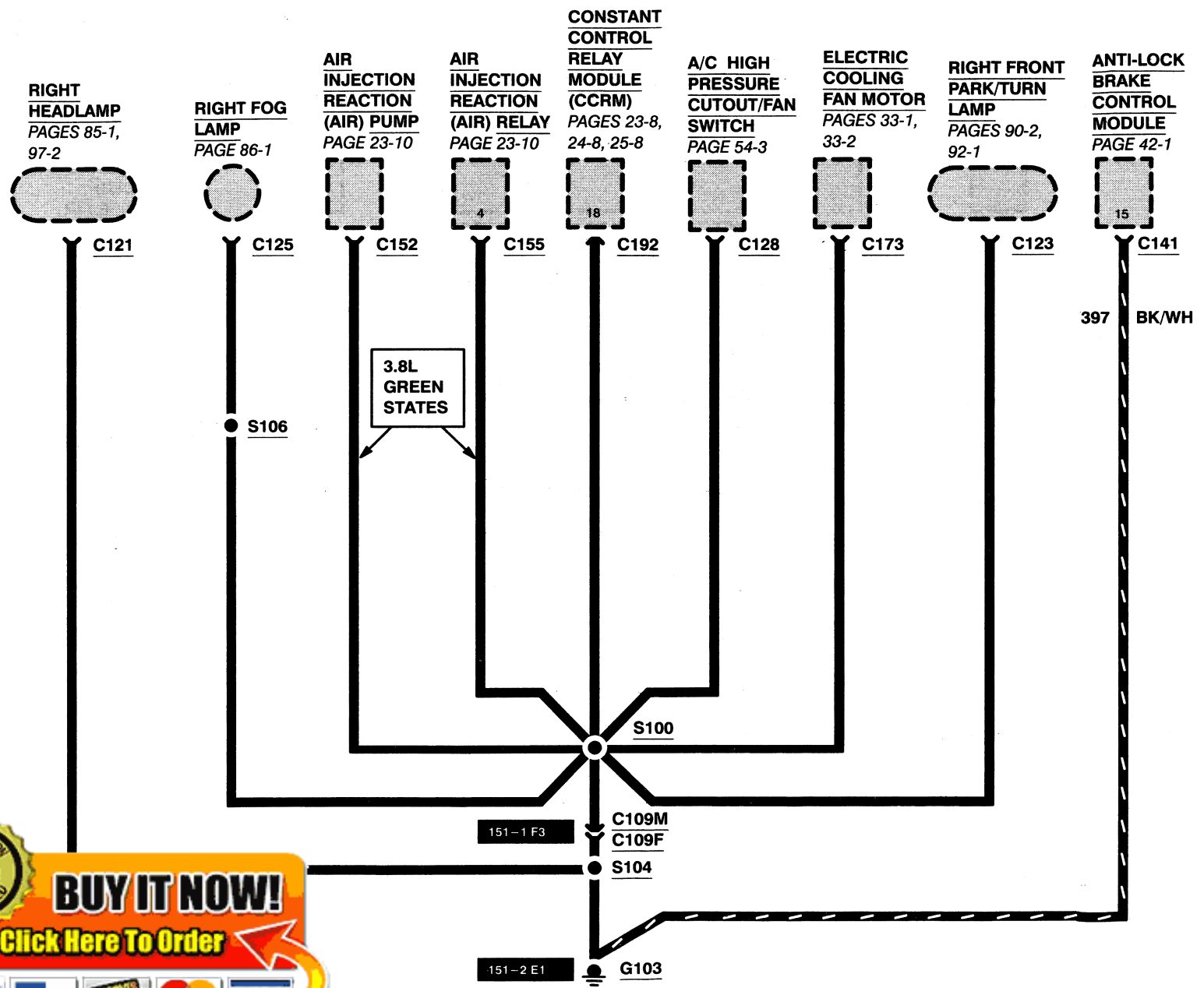

100% SATISFACTION GUARANTEED

BUY IT NOW!

Click Here To Order

PayPal, American Express, Discover, MasterCard, VISA

All wires are 1205 (BK) unless otherwise noted.

POWERTRAIN CONTROL MODULE (PCM)
PAGES 23-1, 24-1, 25-1

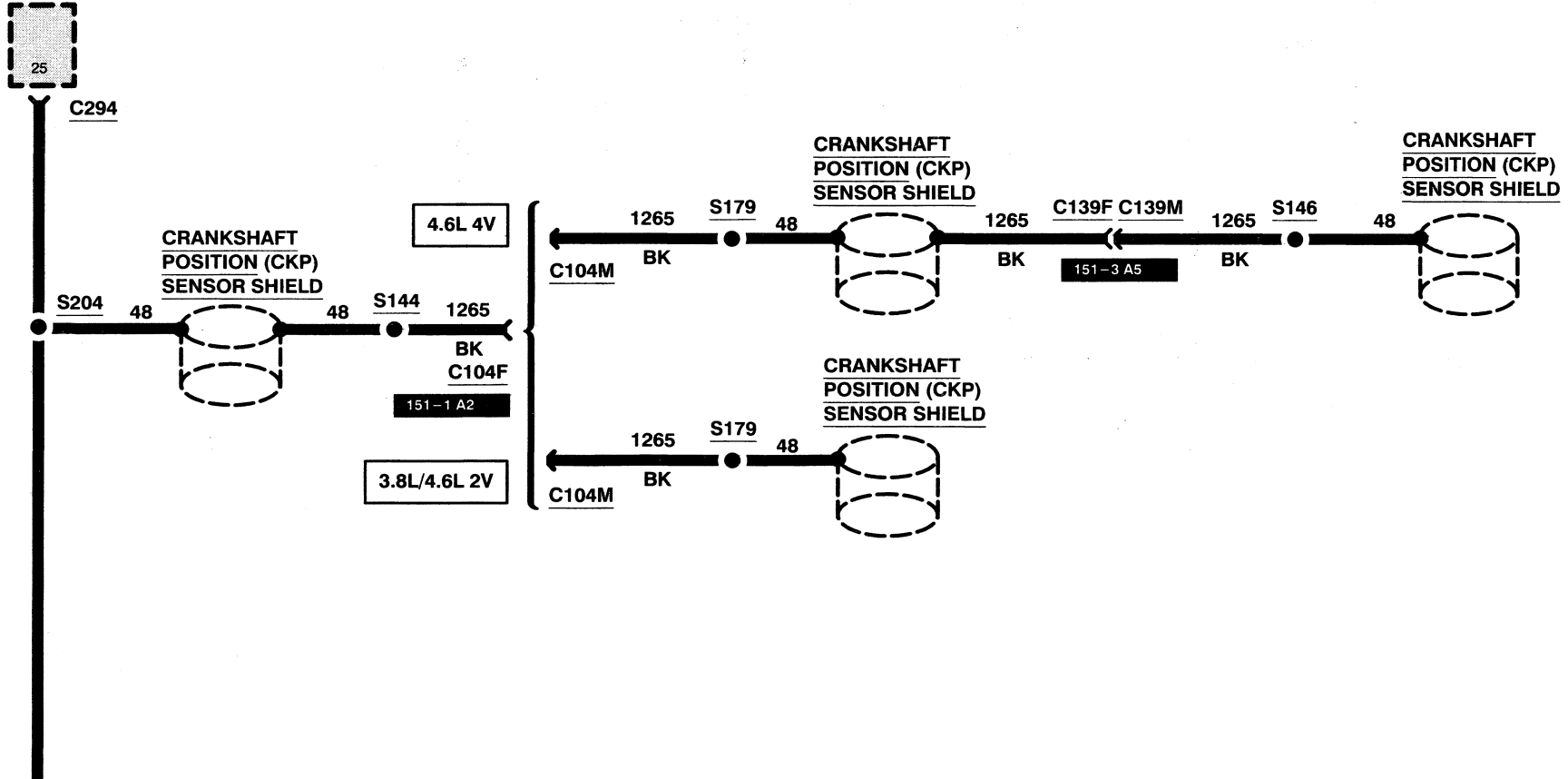

100% SATISFACTION GUARANTEED

BUY IT NOW!

Click Here To Order

PayPal American Express Discover Novus MasterCard VISA

10-5 GROUNDS

1999 MUSTANG

All wires are 57 (BK) unless otherwise noted.

* COUPE

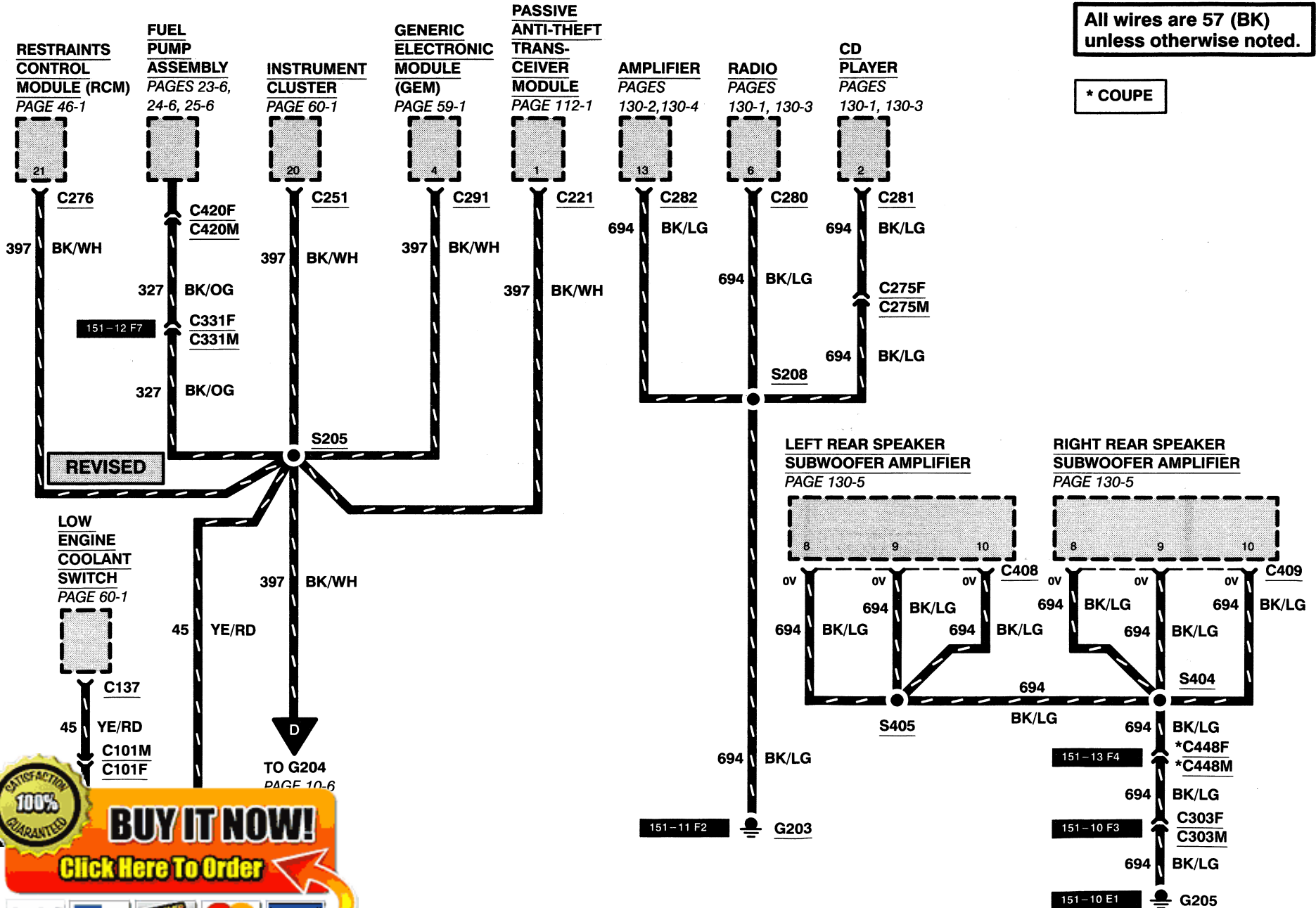

100% SATISFACTION GUARANTEED

BUY IT NOW!

Click Here To Order

GROUNDS 10-6

1999 MUSTANG

All wires are 1205 (BK) unless otherwise noted.

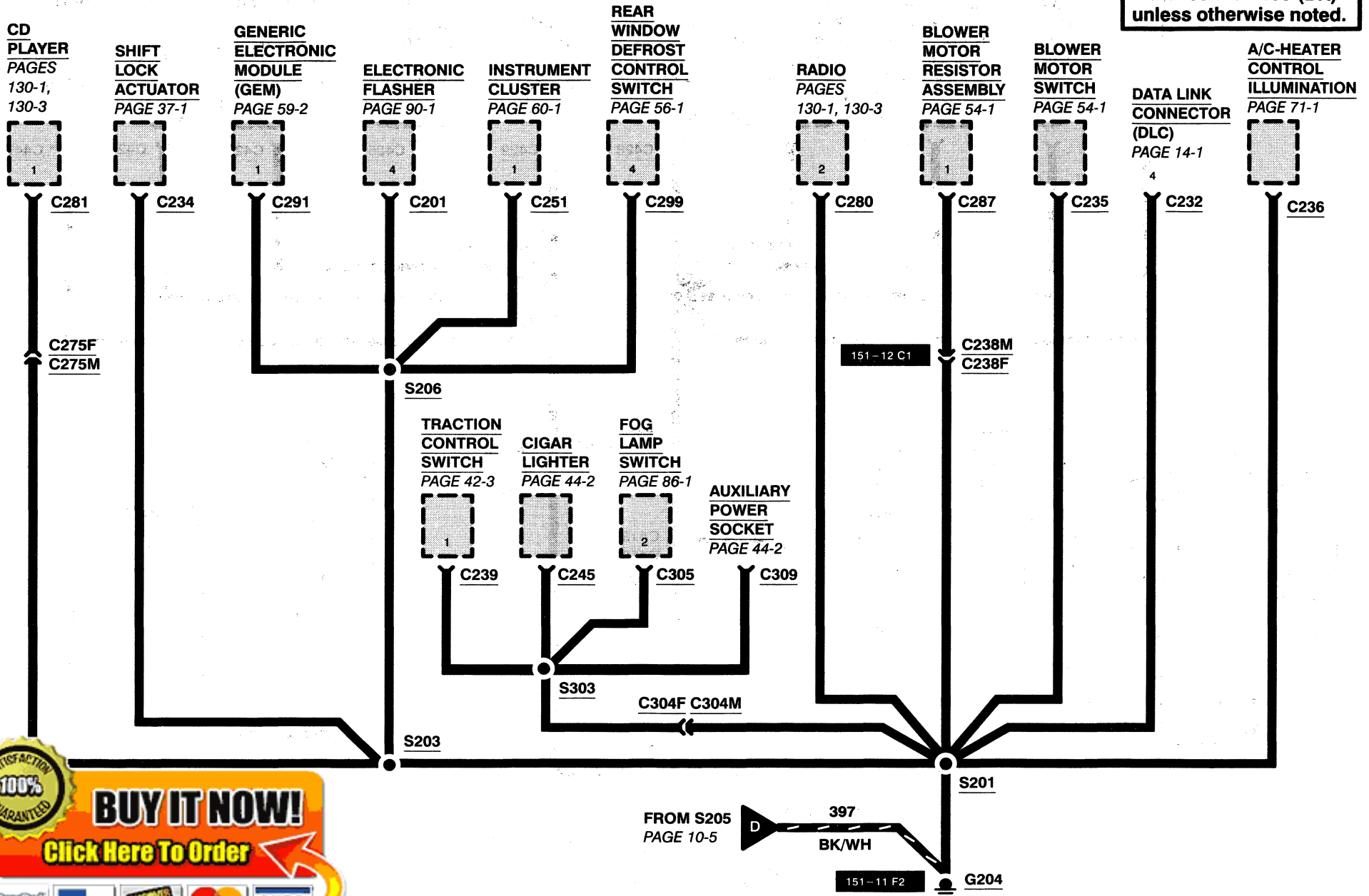

100% SATISFACTION GUARANTEED

BUY IT NOW!

[Click Here To Order](#)

10-7 GROUNDS

1999 MUSTANG

* COBRA

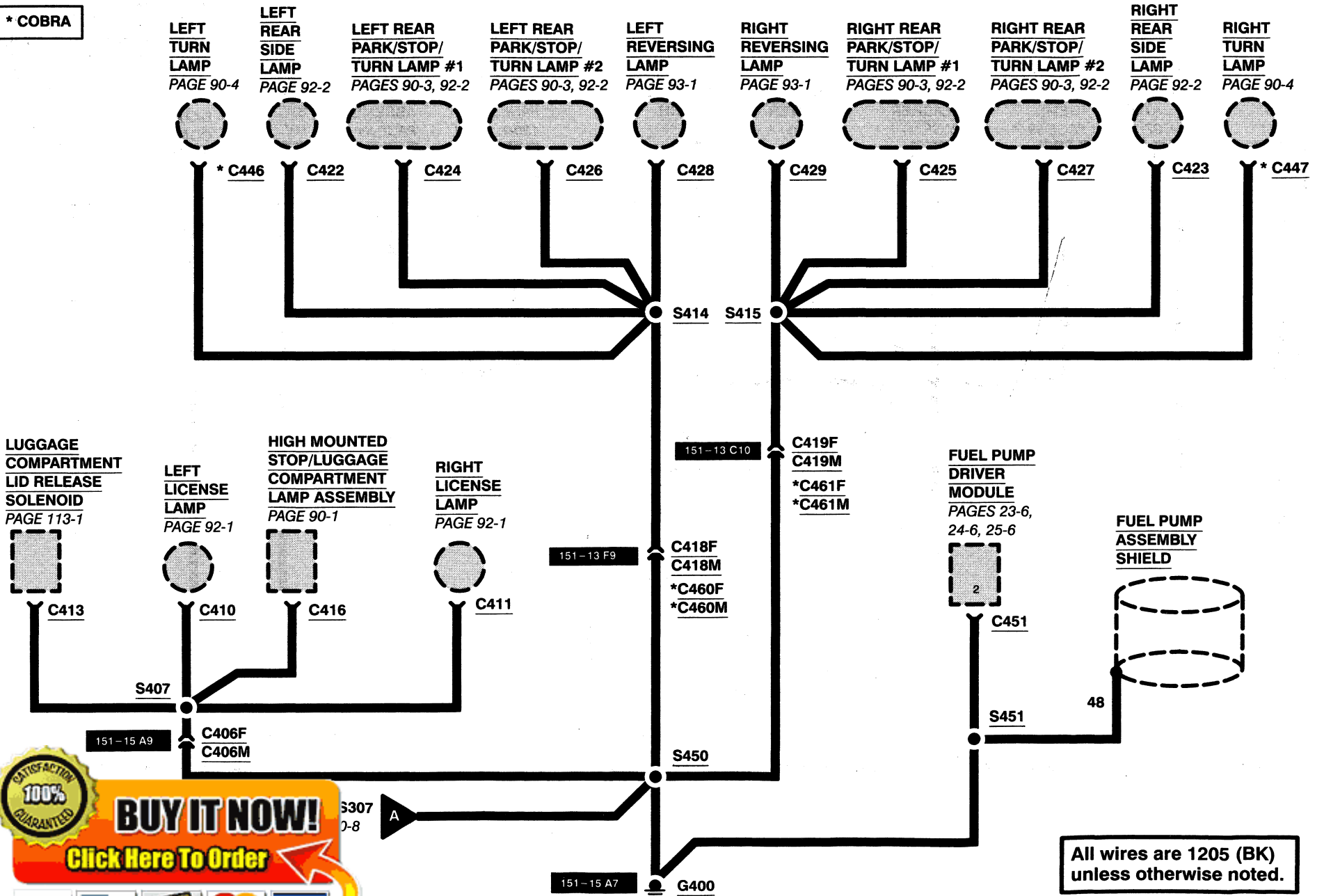

100% SATISFACTION GUARANTEED

BUY IT NOW!

Click Here To Order

PayPal

Discover

MasterCard

VISA

GROUNDS 10-8

1999 MUSTANG

* COUPE
** CONVERTIBLE

All wires are 1205 (BK) unless otherwise noted.

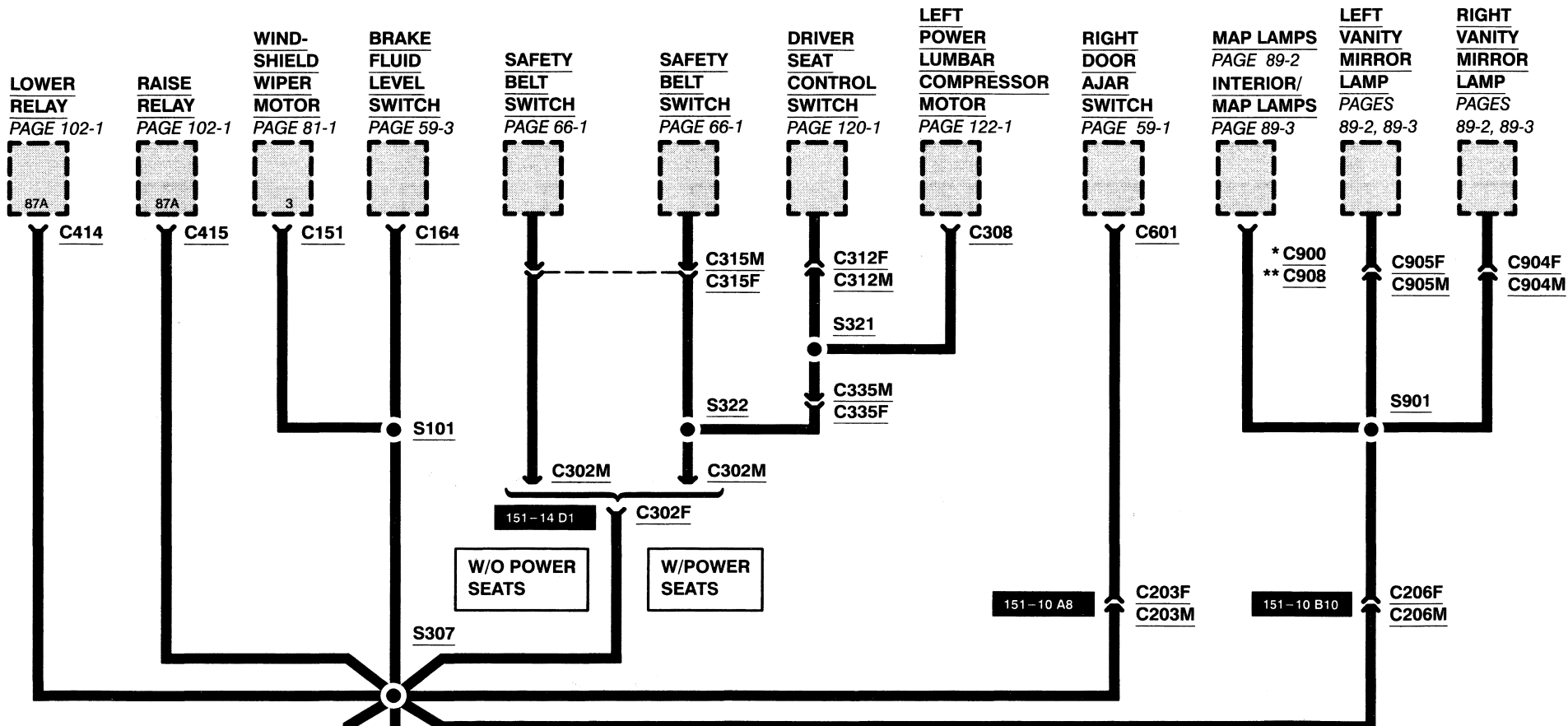

FROM C227 PAGE 10-9
B
COUPE

100% SATISFACTION GUARANTEED

BUY IT NOW!

Click Here To Order

PayPal, Discover, MasterCard, VISA

S450
E 10-7

10-9 GROUNDS

1999 MUSTANG

All wires are 1205 (BK) unless otherwise noted.

EXTERIOR
REAR VIEW
MIRROR
SWITCH
PAGE 124-1

MASTER WINDOW/DOOR
LOCK CONTROL SWITCH
PAGE 100-1

LEFT
DOOR
AJAR
SWITCH
PAGE 59-1

EXTERIOR
REAR VIEW
MIRROR
SWITCH
PAGE 124-1

MASTER
WINDOW/
DOOR LOCK
CONTROL
SWITCH
PAGE 100-1

LEFT
DOOR
AJAR
SWITCH
PAGE 59-1

TRANSMISSION
CONTROL
SWITCH (TCS)
PAGE 29-1

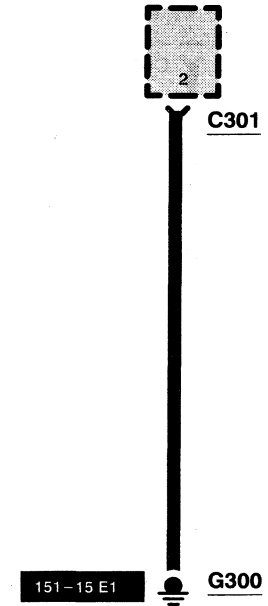
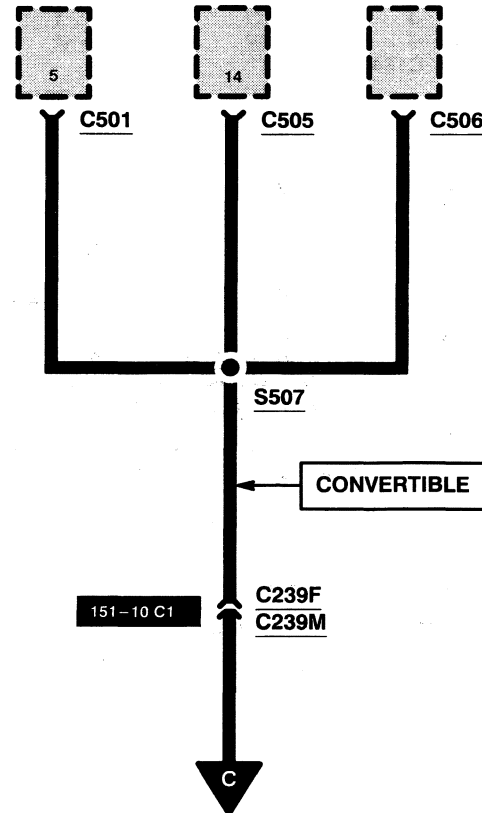
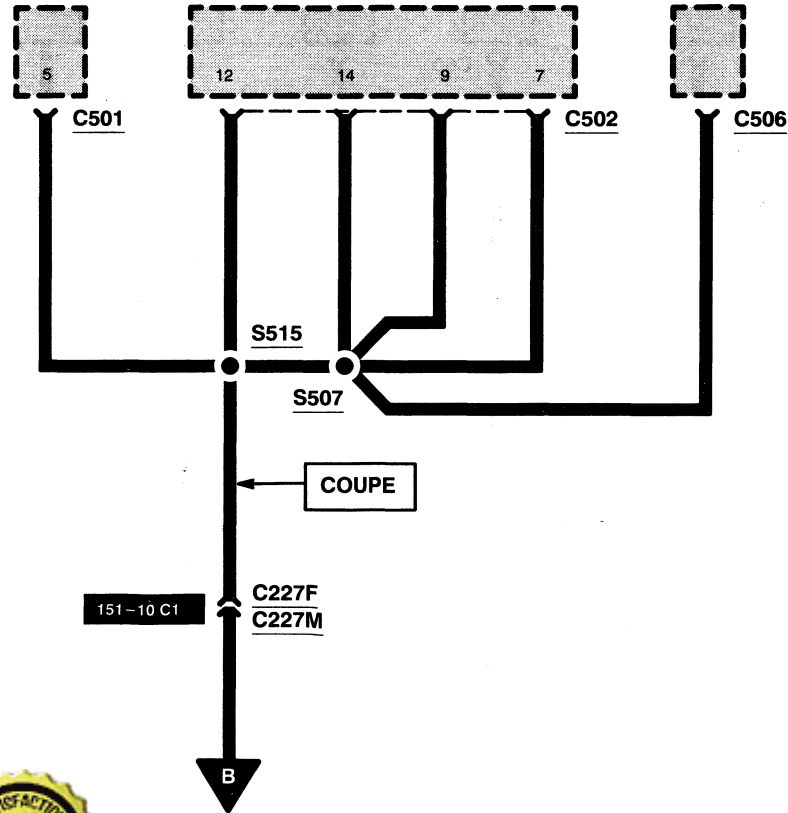

TO S307
PAGE 10-8

100% SATISFACTION GUARANTEED

BUY IT NOW!

Click Here To Order

11-1 FUSE PANEL/CIRCUIT PROTECTION

1999 MUSTANG

CIRCUIT PROTECTION DEVICES

Electrical circuits on this vehicle may be protected by fuses, fusible links, fusible link cartridges, circuit breakers, or a combination of these devices.

BLADE TYPE FUSE

TOP VIEW

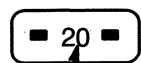

AMPERE RATING

SIDE VIEW

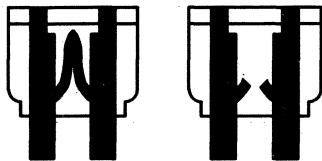

GOOD FUSE

BLOWN FUSE

Blade type fuses have a transparent plastic housing. To check a fuse, pull it from the fuse panel and look at the fuse element through the housing. Always replace a blown fuse with a new fuse that has the same ampere rating.

The ampere rating of a blade type fuse can also be determined by following the color code shown here:

BLADE FUSE COLOR CODING	
AMPERE RATING	HOUSING COLOR
4	Pink
5	Tan

100% SATISFACTION GUARANTEED

BUY IT NOW!

Click Here To Order

FUSIBLE LINK

CUT-AWAY VIEW

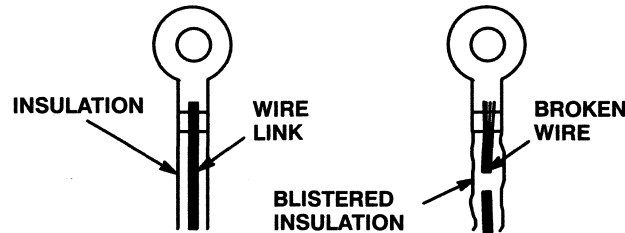

GOOD LINK

BLOWN LINK

Fusible links are short lengths of wire that are smaller in diameter than the wires they are protecting. Fusible link wire is covered with a special thick, non-flammable insulation. An overload condition causes the insulation to blister. If the overload condition continues, the wire link will melt. To check a fusible link, look for blistered insulation. If the insulation is okay, pull lightly on the wire; if the fusible link stretches, the wire has melted.

When replacing fusible links, first cut the protected wire where it is connected to the fusible link. Then, tightly crimp or solder the new link to the protected wire.

Fusible links are often identified by color coding of the insulation, as shown here:

FUSIBLE LINK COLOR CODING	
WIRE LINK SIZE	INSULATION COLOR
20 GA	Blue
18 GA	Brown or Red
16 GA	Black or Orange
14 GA	Green
12 GA	Gray

MAXI-FUSE CARTRIDGE

SIDE VIEW



GOOD



BLOWN

TOP VIEW

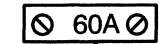

AMPERE RATING

Maxi-fuse cartridges have a transparent colored plastic housing. To check a maxi-fuse cartridge, look at the fuse element through the side of the housing.

To replace a maxi-fuse cartridge, pull it from the fuse box or panel. Always replace a blown maxi-fuse cartridge with a new one having the same ampere rating.

The ampere rating of a maxi-fuse cartridge can also be determined by following the color code shown here:

MAXI-FUSE CARTRIDGE COLOR CODING	
AMPERE RATING	HOUSING COLOR
30	Green
40	Orange
50	Red
60	Blue

CIRCUIT BREAKER

Some circuits are protected by circuit breakers (abbreviated "c. b." in fuse chart). They can be Fuse Panel mounted or in-line. Like fuses, they are rated in amperes.

Each circuit breaker conducts current through an arm made of two types of metal bonded together (bimetal arm). If the arm starts to carry too much current, it heats up. As one metal expands faster than the other the arm bends, opening the contacts. Current flow is broken. A circuit breaker can be the cycling or non-cycling type.

FUSE PANEL MOUNTED CYCLING TYPE

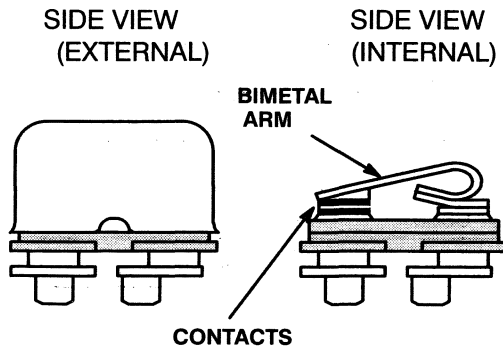

IN-LINE MOUNTED CYCLING TYPE

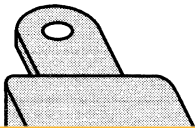

In the cycling type, the bimetal arm cools and straightens out. This cycle repeats as long as the overcurrent exists and power is applied.

FUSE PANEL MOUNTED NON-CYCLING TYPE

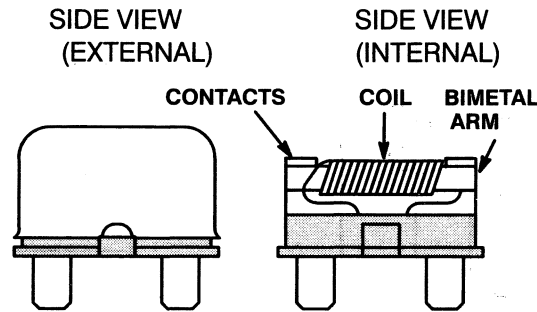

FUSE PANEL MOUNTED MANUAL RESET TYPE

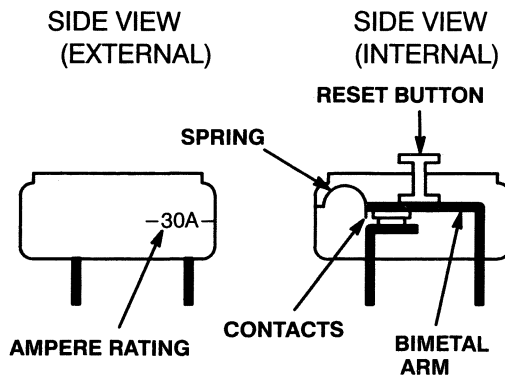

Two types of non-cycling circuit breakers are used; one is reset by removing power from the circuit, and the other is reset by depressing a reset button.

In the first type, there is a coil wrapped around the bimetal arm. When an overcurrent exists and the contacts open, a small current passes through the coil. This current through the coil is not enough to operate a load, but it does heat up both the coil and the bimetal arm. This keeps the arm in the open position until power is removed.

In the second type, a spring pushes the bimetal arm down and holds the contacts together. When an overcurrent condition exists and the bimetal arm heats up, the bimetal arm bends enough to overcome the spring and the contacts snap open. The contacts stay open until the reset button is pushed and the contacts snap together again.

DIODE

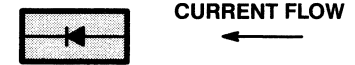

Diodes are electrical devices that permit current to flow in one direction only. The current flows in the direction indicated by the arrow.

100% SATISFACTION GUARANTEED

BUY IT NOW!

Click Here To Order

11-3 FUSE PANEL/CIRCUIT PROTECTION

1999 MUSTANG

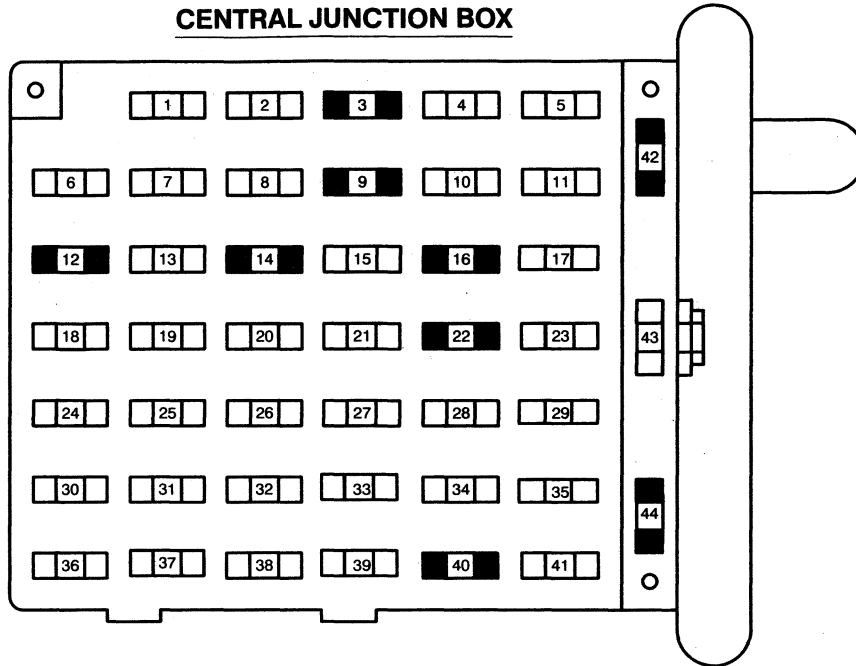

Fuse Position	Amps	Circuits Protected
1	20	Cigar Lighter
2	20	Engine Controls
3	–	NOT USED
4	10	RH Low Beam Headlamp
5	15	Instrument Cluster, Traction Control Switch
6	20	Starter Motor Relay
7	15	GEM, Interior Lamps
8	20	Engine Controls
9	–	NOT USED
10	10	LH Low Beam Headlamp
11	15	Reversing Lamps
12	–	NOT USED
13	15	Electronic Flasher
14	–	NOT USED
15	15	Power Lumbar Seats
16	–	NOT USED
17	15	Speed Control Servo, Shift Lock Actuator
18	15	Electronic Flasher
19	15	Power Mirror Switch, GEM, Anti-Theft Relay, Power Locks, Door Ajar Switches
20	15	Convertible Top Switch
21	5	PCM Instrument Cluster
22	–	NOT USED
23	15	A/C Clutch, Defogger Switch

Fuse Value Amps	Color Code
4	Pink
5	Tan
10	Red
15	Light Blue
20	Yellow
	Natural
	Light Green

100% SATISFACTION GUARANTEED

BUY IT NOW!

Click Here To Order

FUSE PANEL/CIRCUIT PROTECTION 11-4

1999 MUSTANG

Fuse Position	Amps	Circuits Protected
24	30	A/C Heater Control Assembly
25	25	Luggage Compartment Lid Release Switch
26	30	Wiper Motor, Wiper Relays
27	25	Radio
28	15	GEM, Overdrive Cancel Switch
29	15	ABS Module
30	15	DRL Module
31	10	Data Link Connector
32	15	Radio, CD Player, GEM
33	15	Stoplamp Switch, Speed Control Deactivator Switch
34	20	Instrument Cluster, CCRM, Data Link Connector, PATS Transceiver Module
35	15	Shift Lock Actuator, PCM, Speed Control Servo, ABS Module
36	15	Restraints Control Module
37	10	Radio, A/C-Heater Control Illumination, Rear Window Defrost Control Switch, Overdrive Cancel Switch, Instrument Cluster, Fog Lamp Switch
38	20	High Beam Headlamps
39	5	GEM
40	–	NOT USED
41	15	Multifunction Switch/Stoplamps
42	–	NOT USED
43	20	GEM, Master Window/Door Lock Control Switch
44	–	NOT USED



BUY IT NOW!
Click Here To Order 







11-5 FUSE PANEL/CIRCUIT PROTECTION

1999 MUSTANG

BATTERY JUNCTION BOX

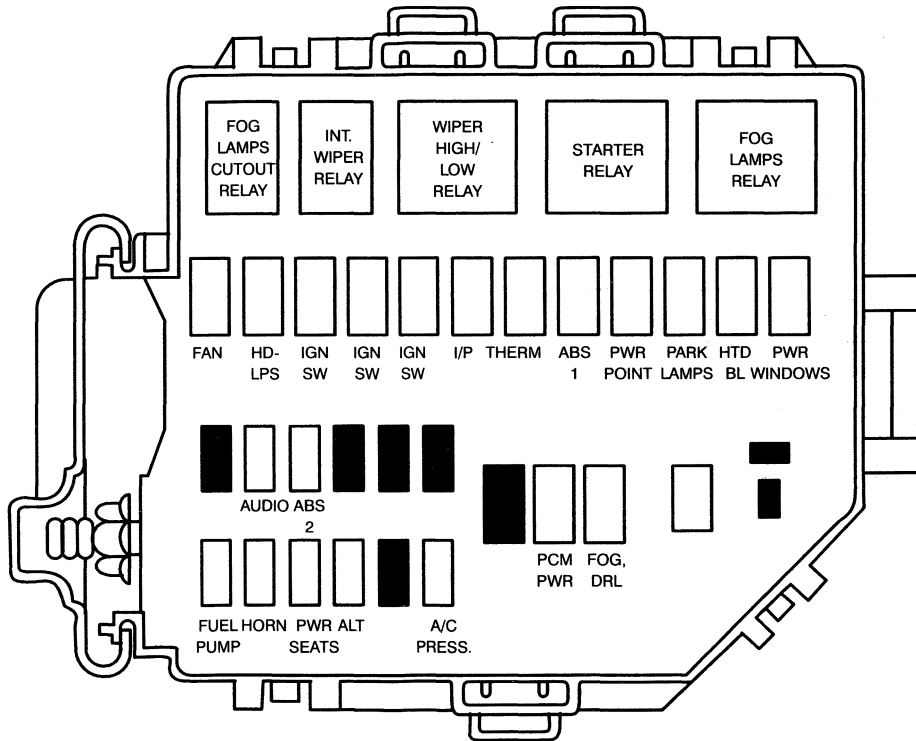

Fuse Position	Amps	Circuits Protected
FAN (3.8L)	30 (c.b.)	Constant Control Relay Module
FAN (4.6L)	50 (Maxi)	Constant Control Relay Module
HD-LPS	30 (Maxi)	Main Light Switch, Multifunction Switch
IGN SW	40 (Maxi)	Starter Motor Relay, Intake Runner Control Module, GEM, Overdrive Cancel Switch, Instrument Cluster
IGN SW	40 (Maxi)	ABS Module, Instrument Cluster, Reversing Lamps, Speed Control Servo, GEM, Shift Lock Actuator, A/C-Heater, Power Windows, Radio, Raise Relay, Lower Relay, Windshield Wiper Motor, Intermittent Wiper Relay, Wiper HIGH/LOW Relay
IGN SW	40 (Maxi)	Restraints Control Module, DRL Module, A/C-Heater, Blower Motor, Electronic Flasher
I/P	40 (Maxi)	Instrument Cluster, PCM
THERM	30 (Maxi)	Secondary Air Injection
ABS1	50 (Maxi)	ABS Module
POWER POINT	20 (Maxi)	Auxiliary Power Point
PARK LAMPS	30 (Maxi)	Main Light Switch
HTD BL	30 (Maxi)	Rear Window Defrost Control
POWER WINDOWS	40 (Maxi)	GEM, Power Door Locks
AUDIO	10 (Mini)	Radio, CD Player
ABS2	20 (Mini)	ABS Module
FUEL PUMP	20 (Mini)	Fuel Pump Relay
HORN	20 (Mini)	Horns, Horn Relay
POWER SEATS	25 (Mini)	Power Seat Switch
ALT	20 (Mini)	Generator
A/C PRESS.	20 (Mini)	Constant Control Relay Module
PCM POWER	30 (Maxi)	Intake Manifold Runner Control

100% SATISFACTION GUARANTEED

BUY IT NOW!

Click Here To Order

153-1 HARNESS CAUSAL PART NUMBER

1999 MUSTANG

HOW TO IDENTIFY A BASIC HARNESS NUMBER BY USING A "C" NUMBER

Understand these symbols before you use the following listing:

THIS MEANS A HARNESS CONNECTION

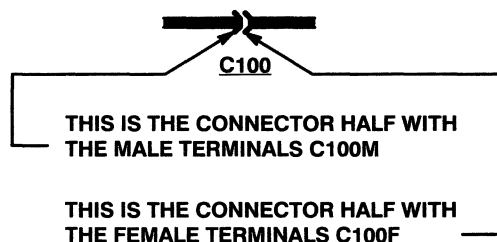

THE DASHED LINE MEANS THAT ALL OF THESE TERMINALS ARE IN THE SAME CONNECTION

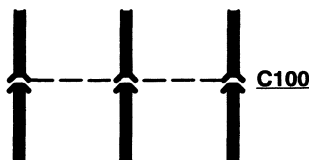

THE UPPER FEMALE TERMINALS ARE IN C100F;
THE LOWER MALE TERMINALS ARE IN C100M

THIS MEANS A COMPONENT CONNECTION

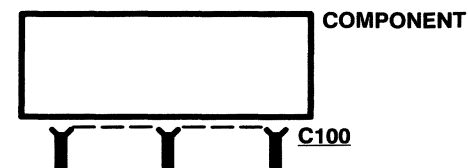

THE F AND M IS NOT USED WITH THE "C" NUMBER

Identify the basic harness part number by:

1. If the problem is in a connector, find the connector "C" number in the Wiring Diagram schematics. Then locate the "C" number in the following listing and read the basic harness part number.
2. If the problem is **not** in a connector (such as a short or broken wire), then choose a connector **located on the same harness** that has the problem. Identify the "C" number of that connector. Locate the "C" number in the following listing and read the basic part number of the harness that has the problem.

100% SATISFACTION GUARANTEED

BUY IT NOW!

Click Here To Order

PayPal American Express Discover MasterCard VISA

HARNES CAUSAL PART NUMBER

153-2

1999 MUSTANG

<u>Connector Number</u>	<u>Wire Assembly</u>	<u>Connector Number</u>	<u>Wire Assembly</u>	<u>Connector Number</u>	<u>Wire Assembly</u>	<u>Connector Number</u>	<u>Wire Assembly</u>
C100 (F)	14290	C114 (3.8L)	9D930	C137 (4.6L)	12B637	C162 (4.6L 4V)	12A581
C100 (M) (3.8L)	14305	C114 (4.6L)	12B637	C138 (3.8L)	14B060	C163	14B060
C100 (M) (4.6L)	12B637	C115	9D930	C138 (4.6L)	12A690	C164	14A005
C101 (F)	12A581	C116	14B060	C139 (F)	12B637	C165 (3.8L)	9D930
C101 (M)	12B637	C118 (3.8L)	9D930	C139 (M)	12B559	C165 (4.6L 2V)	12B637
C102 (F)	12A581	C118 (4.6L 2V)	12B637	C140	PIA	C165 (4.6L 4V)	12B637
C102 (M)	15525	C118 (4.6L 4V)	12B559	C141	14290	C166 (4.6L 4V)	12B559
C103	12A581	C119 (F)	12A581	C143 (F)	14B060	C167	12A581
C104 (F)	12A581	C119 (M) (Automatic)	7C078	C143 (M)	12B637	C168 (3.8L)	9D930
C104 (M) (3.8L)	9D930	C119 (M) (Manual)	15525	C144	14290	C168 (4.6L)	12B637
C104 (M) (4.6L 2V)	12B637	C120	14290	C145	12A581	C169 (4R70W)	7C078
C104 (M) (4.6L 4V)	12B637	C121	14290	C147	9D930	C169 (T5OD)	15525
C105 (F)	14401	C122	14290	C148	14290	C169 (Automatic)	7C078
C105 (M)	14290	C123	12A581	C149	14290	C169 (Manual)	15525
C106 (F) (3.8L)	12A581	C124	14290	C150	14290	C170	14290
C106 (F) (4.6L 2V)	12A581	C125	12A581	C151	14A005	C171	12A581
C106 (F) (4.6L 4V)	12B637	C126	14290	C152 (3.8L)		C173	12A581
C106 (M) (Automatic)	7C078	C127	14290	(Green States)	12A581	C174 (4.6L 4V)	12B559
C106 (M) (Manual)	15525	C128	12A581	C153 (3.8L)	14305	C177 (3.8L)	9D930
C107 (F)	14290	C129 (4R70W)	7C078	C153 (4.6L)	12B637	C177 (4.6L 2V)	12B637
C107 (M)	14A005	C129 (T45)	15525	C154 (3.8L)	14305	C177 (4.6L 4V)	12B637
C108 (F)	12A581	C129 (T5OD)	15525	C154 (4.6L)	12B637	C178 (3.8L)	9D930
C108 (M)	14290	C130	12A581	C155 (3.8L)		C178 (4.6L 2V)	12B637
C109 (F)	14290	C131 (F)	10A998	(Green States)	12A581	C178 (4.6L 4V)	12B637
C109 (M)	12A581	C131 (M)	9D930	C156 (4.6L 4V)	12B637	C179 (3.8L)	9D930
C110	7C078	C132	7C078	C157	14290	C179 (4.6L 2V)	12B637
(3.8L)	9D930	C133 (4R70W)	7C078	C158	14290	C179 (4.6L 4V)	12B637
		C133 (Manual)	15525	C159 (3.8L)	12A581	C180 (3.8L)	9D930
		C135 (F) (3.8L)	12A581	C159 (4.6L 2V)	12B637	C180 (4.6L 2V)	12B637
		C135 (M) (3.8L)	12B566	C159 (4.6L 4V)	12B559	C180 (4.6L 4V)	12B637
		C136	14290	C160 (4.6L 4V)	12A581	C181 (3.8L)	9D930
		C137 (3.8L)	9D930	C161	15525		

100% SATISFACTION GUARANTEED

BUY IT NOW!

Click Here To Order

PayPal American Express Discover MasterCard VISA

153-3 HARNESS CAUSAL PART NUMBER

1999 MUSTANG

<u>Connector Number</u>	<u>Wire Assembly</u>	<u>Connector Number</u>	<u>Wire Assembly</u>	<u>Connector Number</u>	<u>Wire Assembly</u>	<u>Connector Number</u>	<u>Wire Assembly</u>
C181 (4.6L 2V)	12B637	C198 (3.8L)	9D930	C218 (F)	14401	C245	14B079
C181 (4.6L 4V)	12B599	C198 (4.6L)	12B637	C218 (M)	14A005	C246	14401
C182 (3.8L)	9D930	C200 (F)	12A581	C219 (F)	14401	C248 (F)	14631
C182 (4.6L 2V)	12B637	C200 (M)	14A005	C219 (M)	14A005	C248 (M)	14A005
C182 (4.6L 4V)	12B637	C201	14401	C220	14401	C250	14401
C183 (3.8L)	9D930	C202 (F)	14A005	C221	14401	C251	14401
C183 (4.6L 2V)	12B637	C202 (M)	12A581	C222	PIA	C252 (F)	19B113
C183 (4.6L 4V)	12B637	C204 (F)	14630	C224 (F)	14631	C252 (M)	14401
C184 (3.8L)	9D930	C204 (M)	14A005	C224 (M)	14A005	C253 (F)	12638
C184 (4.6L 2V)	12B637	C205 (F)	19A041	C226	14401	C253 (M)	14A005
C184 (4.6L 4V)	12B637	C205 (F)	14630	C227 (F)	14631	C255	14A005
C185 (3.8L)	9D930	C205 (M)	14A005	C227 (M)	14A005	C257 (F)	14401
C185 (4.6L 2V)	12B637	C206 (F) (Convert.)	14335	C228	14401	C257 (M)	19B113
C185 (4.6L 4V)	12B637	C206 (F) (Coupe)	14334	C229 (F)	14631	C258 (F)	14401
C186 (3.8L)	9D930	C206 (M)	14A005	C229 (M)	14A005	C258 (M)	19B113
C186 (4.6L 2V)	12B637	C207 (F)	14630	C230	14401	C259 (F)	12A581
C186 (4.6L 4V)	12B637	C207 (M)	14A005	C231	14401	C259 (M)	14A005
C187 (4.6L 2V)	12B637	C208 (F) (Convert.)	14335	C232	14401	C260 (F)	9D821
C187 (4.6L 4V)	12B637	C208 (F) (Coupe)	14334	C233 (F)	14401	C260 (M)	14A005
C188 (4.6L 2V)	12B637	C208 (M)	14A005	C233 (M)	PIA	C261	14A005
C188 (4.6L 4V)	12B637	C209	14401	C234	14401	C262	PIA
C189	12A581	C210 (F)	14A005	C235	14401	C270 (F)	14401
C191	9D930	C210 (M)	14401	C236	14401	C270 (M)	PIA
C192	12A581	C211	14401	C238 (F)	14401	C271	14401
C193 (4R70W)	7C078	C212 (F)	14A005	C238 (M)	18C629	C272 (F)	PIA
C193 (T45)	15525	C212 (M)	14401	C239	14B079	C272 (M)	PIA
C193 (TOD)	15525	C213 (F)	14401	C239 (F)	14631	C274	19B113
C193 (TOD)	12B637	C213 (M)	12A581	C239 (M)	14631	C275 (F)	19B113
C194	12A581	C215	PIA	C240	13B319	C275 (M)	14401
C195	12A581	C216 (F)	14401	C241	13B319		
C196	12A581	C216 (M)	12A581	C242	14A005		
C197	12A581	C217	14401	C243	PIA		

100% SATISFACTION GUARANTEED

BUY IT NOW!

Click Here To Order

PayPal American Express Discover MasterCard VISA

HARNES CAUSAL PART NUMBER

153-4

1999 MUSTANG

<u>Connector Number</u>	<u>Wire Assembly</u>	<u>Connector Number</u>	<u>Wire Assembly</u>	<u>Connector Number</u>	<u>Wire Assembly</u>	<u>Connector Number</u>	<u>Wire Assembly</u>
C276	14401	C311	14C719		14A699	C421	19B516
C278	19B113	C312 (with power lumbar)		C335 (M) (without power lumbar)	14B084	C422	13410
C279	19B113		14B084		14A005	C423	13407
C280	14401	C312 (without power lumbar)		C336	14A005	C424	13410
C281	19B113		14A699	C352	14401	C425	13407
C282	14401	C313	14B084	C355	14C719	C426	13410
C283	PIA	C315 (with power seats)		C400	14A005	C427	13407
C284	PIA		14C719	C401	14A005	C428	13410
C285	14401	C315 (without power seats)		C402	14A005	C429	13407
C286	18C629		14A546	C403	14A005	C430	14405
C288 (F)	13B319	C317	14B079	C404	14A005	C431	PIA
C288 (M)	14401	C318	14A005	C405 (F)	14405	C432 (F) (Convert.)	18C619
C290	14401	C319	14A005	C405 (M)	14A005	C432 (F) (Coupe)	18C618
C291	14401	C320	14A005	C406 (F)	19B516	C432 (M)	14A005
C292	14A005	C321	14A005	C406 (M)	14A005	C433 (Convert.)	18C619
C294	12A581	C322	14A005	C407	14405	C433 (Coupe)	18C618
C299	14401	C323	14A005	C408 (Convertible)	14A005	C434	18C620
C300 (F)	14A005	C324	14A005	C408 (Coupe)	19B113	C436	14A005
C300 (M)	14B084	C325 (F)	19B113	C409 (Convertible)	14A005	C437	14A005
C301	14A005	C325 (M)	14A005	C409 (Coupe)	19B113	C438	14A005
C302 (F)	14A005	C326	14A005	C410	19B516	C439 (Convertible)	14A005
C302 (M) (with power seats)		C328	14C719	C411	19B516	C439 (Coupe)	19B113
	14C719	C329 (F)	14A005	C413	19B516	C440 (Convertible)	14A005
C302 (M) (without power seats)		C329 (M)	14B079	C414	14A005	C440 (Coupe)	19B113
	14A546	C330 (F)	14401	C415	14A005	C441 (F)	19B113
C303 (F)	14A005	C330 (M)	14A005	C416	19B516	C441 (M)	PIA
C303 (M)	19B113	C331 (F)	14A005	C417	14A005	C442	PIA
		C331 (M)	14401	C418 (F)	13410	C443	PIA
		C332 (F)	14A005	C418 (M)	14A005	C444	14A005
		C332 (M)	14401	C419 (F)	13407	C445	14A005
		C335 (F)	14C719	C419 (M)	14A005	C446	13410
		C335 (M) (with power lumbar)		C420	14A005		



BUY IT NOW!

[Click Here To Order](#)



153-5 HARNESS CAUSAL PART NUMBER

1999 MUSTANG

<u>Connector Number</u>	<u>Wire Assembly</u>	<u>Connector Number</u>	<u>Wire Assembly</u>	<u>Connector Number</u>	<u>Wire Assembly</u>
C447	13407	C905 (Coupe)	14334		
C448 (F)	19B113	C1000 (M)	12B237		
C448 (M)	14A005	C1001	19A041		
C450	14A005	C1003 (4.6L 4V)	12B637		
C451	14A005	C1004 (F) (4.6L 4V)	12B637		
C460 (F)	13410	C1004 (M) (4.6L 4V)	12B559		
C460 (M)	14A005	C1004 (F) (4.6L 4V)	12B637		
C461 (F)	13407	C1005 (F) (4.6L)	12A690		
C461 (M)	14A005	C1005 (M) (4.6L 2V)	12B637		
C501	14631	C1005 (M) (4.6L 4V)	12B637		
C502	14631	C1006 (3.8L)	14305		
C503	14631	C1006 (4.6L 2V)	12B637		
C504	14631	C1007 (F)	12B637		
C505	14631	C1007 (M)	12A581		
C506	14631	C1008 (M)	14290		
C509	14631	C1009	12B637		
C510	14631	C1010	12B637		
C511	14631	C1011 (F)	12B559		
C601	14630	C1011 (M)	12A581		
C602	14630	C1111	12B637		
C603	14630	C1081	12B637		
C604	14630	C1082	12B637		
C609	14630	C1083	12B637		
C610	14630	C1084	12B637		
C611	14630	C1085	12B637		
C900	14334	C1086	12B637		
C901	14335	C1087	12B637		
C902		C1088	12B637		
C903		C1200	14B060		
C904		C1201	14B060		
C905 (Convertible)		C1202	14B060		

100% SATISFACTION GUARANTEED

BUY IT NOW!

Click Here To Order

PayPal American Express Discover MasterCard VISA

BUY IT NOW!
Click Here To Order

100% SATISFACTION GUARANTEE

PayPal
MasterCard
VISA
Discover
American Express

160-1 VEHICLE REPAIR LOCATION CODES

1999 MUSTANG

VEHICLE REPAIR LOCATION CODES

TO PINPOINT THE ACTUAL VEHICLE LOCATION OF A REPAIR, THE VEHICLE REPAIR LOCATION CODE IS REQUIRED. FOR EXAMPLE, AN "X" HAS BEEN PLACED IN THE QUADRANT OF THE VEHICLE DIAGRAMS INDICATING THE LOCATION OF THE REPAIR. SEE DIAGRAMS.

LOCATION CODE, FOR THE EXAMPLE: A5/FU – (UNDER THE FLOOR OF DRIVER'S LEFT FOOT.)

FRONT/REAR DIRECTION
FRONT

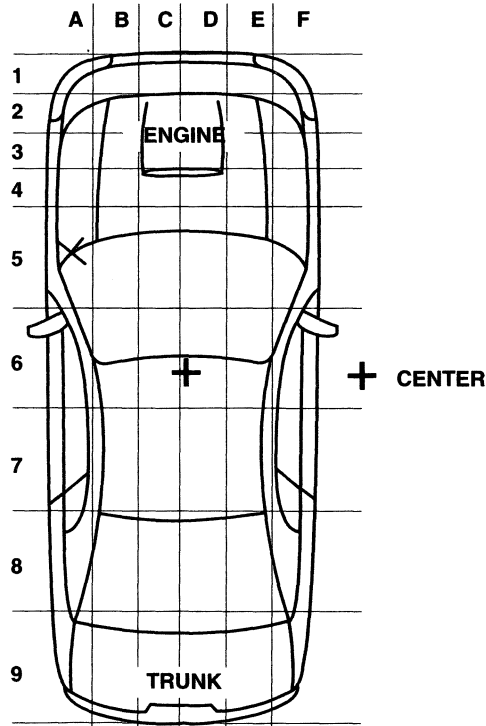

OVER/UNDER DIRECTION

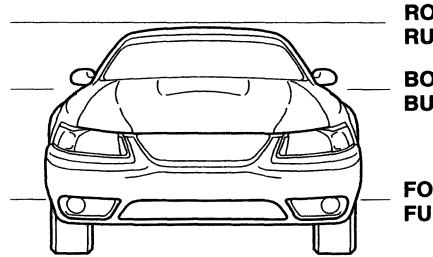

- R = ROOF LINE
- RO = ROOF OVER
- RU = ROOF UNDER
- B = BELT LINE
- BO = BELT OVER
- BU = BELT UNDER
- F = FLOOR PAN
- FO = FLOOR OVER
- FU = FLOOR UNDER

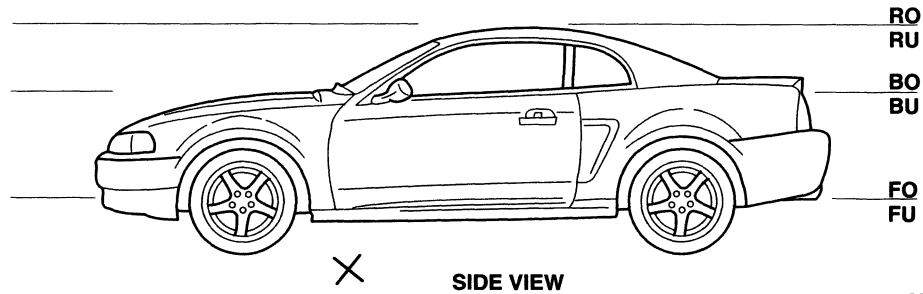

MUSTANG
FCS-12121-99

SATISFACTION 100% GUARANTEED

BUY IT NOW!

Click Here To Order

WE WANT TO HEAR FROM YOU

Your suggestions will help us to improve future editions of this manual.

Instructions:

- Use only one form for each publication
 - Use separate form for each concern
 - **Do not** use this form to order publications
 - Mail the completed form to the address on the reverse side
- OR**
- FAX the completed form to (313) 565-7022

Date: _____

- Publication:**
- | | |
|--|--|
| <input type="checkbox"/> Passenger Car Workshop Manual | <input type="checkbox"/> Body Repair Manual |
| <input type="checkbox"/> Owner Guide | <input type="checkbox"/> Truck Workshop Manual |
| <input type="checkbox"/> Wiring Diagram/EVTM | <input type="checkbox"/> PC/ED Manual |

Vehicle Line: _____

Model Year: _____

Please check the area in which the concern is located in the publication:

- | | | |
|---|---|---|
| <input type="checkbox"/> Body | <input type="checkbox"/> Transmission/Transaxle | <input type="checkbox"/> Battery/Charging |
| <input type="checkbox"/> Frame and Mounting | <input type="checkbox"/> Clutch | <input type="checkbox"/> Audio |
| <input type="checkbox"/> Engine | <input type="checkbox"/> Exhaust | <input type="checkbox"/> Lighting |
| <input type="checkbox"/> Suspension | <input type="checkbox"/> Fuel | <input type="checkbox"/> Electrical |
| <input type="checkbox"/> Driveline | <input type="checkbox"/> Climate Control | <input type="checkbox"/> Schematics |
| <input type="checkbox"/> Brakes | <input type="checkbox"/> Instrumental Warning | <input type="checkbox"/> Pinpoint Test |
| <input type="checkbox"/> Steering | | |

Section and Pages: _____

Explain your concern or suggestion below: (Please print)

What do you think is the main cause of your concern?

- Missing Information Inaccurate Information Incomplete Information

Please tell us who you are: (Please print)

Your Name: _____

Company Name: _____

Street: _____

City: _____ State: _____ Zip/Postal Code: _____

Phone Number: _____ FAX Number: _____

Occupation: (Please mark box)

- | | |
|--|--|
| <input type="checkbox"/> Ford Dealership Technician | <input type="checkbox"/> Ford Dealership Service Manager |
| <input type="checkbox"/> Home Mechanic | <input type="checkbox"/> Engineer |
| <input type="checkbox"/> Technician - Other than Ford Dealership | <input type="checkbox"/> Other: _____ |

Are there features of this publication that you would like to see changed or expanded?

- Organization Technical Detail Format and Style Other: _____

How would you suggest we change the publication?



BUY IT NOW!

Click Here To Order



Form No: TSO-PUB-F006
Revision 6

01/21/00 - Previous versions may not be used

DO NOT STAPLE — USE TRANSPARENT TAPE

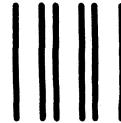

NO POSTAGE
NECESSARY
IF MAILED
IN THE
UNITED STATES

BUSINESS REPLY MAIL

FIRST CLASS

PERMIT NO. 400

DEARBORN, MI

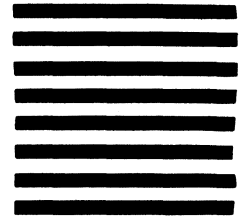

POSTAGE WILL BE PAID BY ADDRESSEE

Technical Service Publications
P.O. Box 2728
Dearborn, MI 48123-9905



BUY IT NOW!

Click Here To Order



WE WANT TO HEAR FROM YOU

Your suggestions will help us to improve future editions of this manual.

Instructions:

- Use only one form for each publication
 - Use separate form for each concern
 - **Do not** use this form to order publications
 - Mail the completed form to the address on the reverse side
- OR**
- FAX the completed form to (313) 565-7022

Date: _____

- Publication:**
- | | |
|--|--|
| <input type="checkbox"/> Passenger Car Workshop Manual | <input type="checkbox"/> Body Repair Manual |
| <input type="checkbox"/> Owner Guide | <input type="checkbox"/> Truck Workshop Manual |
| <input type="checkbox"/> Wiring Diagram/EVTM | <input type="checkbox"/> PC/ED Manual |

Vehicle Line: _____

Model Year: _____

Please check the area in which the concern is located in the publication:

- | | | |
|---|---|---|
| <input type="checkbox"/> Body | <input type="checkbox"/> Transmission/Transaxle | <input type="checkbox"/> Battery/Charging |
| <input type="checkbox"/> Frame and Mounting | <input type="checkbox"/> Clutch | <input type="checkbox"/> Audio |
| <input type="checkbox"/> Engine | <input type="checkbox"/> Exhaust | <input type="checkbox"/> Lighting |
| <input type="checkbox"/> Suspension | <input type="checkbox"/> Fuel | <input type="checkbox"/> Electrical |
| <input type="checkbox"/> Driveline | <input type="checkbox"/> Climate Control | <input type="checkbox"/> Schematics |
| <input type="checkbox"/> Brakes | <input type="checkbox"/> Instrumental Warning | <input type="checkbox"/> Pinpoint Test |
| <input type="checkbox"/> Steering | | |

Section and Pages: _____

Explain your concern or suggestion below: (Please print)

What do you think is the main cause of your concern?

- Missing Information Inaccurate Information Incomplete Information

Please tell us who you are: (Please print)

Your Name: _____

Company Name: _____

Street: _____

City: _____ **State:** _____ **Zip/Postal Code:** _____

Phone Number: _____ **FAX Number:** _____

Occupation: (Please mark box)

- | | |
|--|--|
| <input type="checkbox"/> Ford Dealership Technician | <input type="checkbox"/> Ford Dealership Service Manager |
| <input type="checkbox"/> Home Mechanic | <input type="checkbox"/> Engineer |
| <input type="checkbox"/> Technician - Other than Ford Dealership | <input type="checkbox"/> Other: _____ |

Are there features of this publication that you would like to see changed or expanded?

- Organization Technical Detail Format and Style Other: _____

How would you suggest we change the publication?



BUY IT NOW!

Click Here To Order



DO NOT STAPLE — USE TRANSPARENT TAPE



NO POSTAGE
NECESSARY
IF MAILED
IN THE
UNITED STATES

BUSINESS REPLY MAIL
FIRST CLASS PERMIT NO. 400 DEARBORN, MI

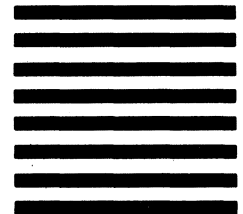

POSTAGE WILL BE PAID BY ADDRESSEE

Technical Service Publications
P.O. Box 2728
Dearborn, MI 48123-9905



100% SATISFACTION GUARANTEED

BUY IT NOW!

Click Here To Order



**TECHNICAL
SUPPORT OPERATIONS**

Ford Customer Service Division



FCS-12121-99

AUGUST 2000

LITHO IN U.S.A.
PG-304

**COPYRIGHT © 1999
FORD MOTOR COMPANY**