

1 • 9 • 9 • 9

# F-150 F-250

## VOLUME 1 & 2

### DEMO

This DEMO contains only a few pages of the entire manual/product.

Not all Bookmarks work on the Demo, but they do on the full version.

#### Features:

- Searchable text
- Printable pages
- Bookmarked for easy navigation
- High Resolution images
- Zoom to see exact details
- Money back Guarantee
- Available on USB and eBook download



[Buy Now](#)



## WORKSHOP MANUAL



**BUY IT NOW!**

[Click Here To Order](#)



License #84356800

Copyright © 2025, Forel Publishing Company, LLC, Woodbridge, Virginia

All Rights Reserved. No part of this book may be used or reproduced in any manner whatsoever without written permission of Forel Publishing Company, LLC. For information write to Forel Publishing Company, LLC, Woodbridge, VA 22192

**1999 Ford F-150 F-250 Truck Workshop Manual**  
**(Volume 1 and 2)**  
**EAN: 978-1-60371-483-9**  
**ISBN: 1-60371-483-9**

Forel Publishing Company, LLC  
Woodbridge, VA 22192  
Email: [sales@ForelPublishing.com](mailto:sales@ForelPublishing.com)  
<https://www.ForelPublishing.com>



This publication contains material that is reproduced and distributed under a license from Ford Motor Company. No further reproduction or distribution of the Ford Motor Company material is allowed without the express written permission of Ford Motor Company.

---

## Note from the Publisher

This product was created from the original Ford Motor Company's publication. Every effort has been made to use the original scanned images, however, due to the condition of the material; some pages have been modified to remove imperfections.

---

## Disclaimer

Although every effort was made to ensure the accuracy of this book, no representations or warranties of any kind are made concerning the accuracy, completeness or suitability of the information, either expressed or implied. As a result, the information contained within this book should be used as general information only. The author and Forel Publishing Company, LLC shall have neither liability nor responsibility to any person or entity with respect to any loss or damage caused, or alleged to be caused, directly or indirectly by the information contained in this book. Further, the publisher and author are not engaged in rendering legal or other professional services. If legal, mechanical, electrical, or other expert assistance is required, the professional should be sought.



1 • 9 • 9 • 9

# F-150 F-250

VOLUME I



**WORKSHOP MANUAL**



**BUY IT NOW!**

**Click Here To Order**



License #84356800

# TABLE OF CONTENTS

## INTRODUCTION

### **GROUP 1** GENERAL INFORMATION

00 Service Information

### **GROUP 2** CHASSIS

04 Suspension

05 Driveline

06 Brake System

11 Steering System

### **GROUP 4** ELECTRICAL

12 Climate Control System

13 Instrumentation and Warning System

14 Battery and Charging System

15 Audio Systems

17 Lighting

18 Electrical Distribution

19 Electronic Feature Group

### **GROUP 5** BODY AND PAINT

01 Body

02 Frame and Mounting

## INDEX

All rights reserved. Reproduction by any means, electronic or mechanical, including photocopying, recording, or by any information storage and retrieval system or translation in whole or part is not authorized without the prior written authorization from Ford Motor Company.



**BUY IT NOW!**

**Click Here To Order**

PayPal

Discover  
Cards

DISCOVER  
NEWUS

MasterCard

VISA

# INTRODUCTION

**NOTE:** The descriptions and specifications contained in this manual were in effect at the time this manual was approved for printing. Ford Motor Company reserves the right to discontinue models at any time, or change specifications or design without notice and without incurring any obligation.

## IMPORTANT SAFETY NOTICE

Appropriate service methods and procedures are essential for the safe, reliable operation of all motor vehicles as well as the personal safety of the individual doing the work. This manual provides general directions for performing service with tested, effective techniques. Following them will help assure reliability.

There are numerous variations in procedure, techniques, tools and parts for servicing vehicles, as well as in the skill of the individual doing the work. This manual cannot possibly anticipate all such variations and provide advice or cautions as to each. Accordingly, anyone who departs from the instructions provided in this manual must first establish that he compromises neither his personal safety nor the vehicle integrity by his choice of methods, tools or parts.

## NOTES, CAUTIONS, AND WARNINGS

As you read through the procedures, you will come across **NOTES**, **CAUTIONS**, and **WARNINGS**. Each one is there for a specific purpose. **NOTES** give you added information that will help you to perform a particular procedure. **CAUTIONS** are given to prevent you from making an error that could damage the vehicle. **WARNINGS** remind you to be especially careful in those areas where carelessness can cause you personal injury. The following list contains some general **WARNINGS** that you should follow when you work on a vehicle.

- ALWAYS WEAR SAFETY GLASSES FOR EYE PROTECTION.
- USE SAFETY STANDS WHENEVER A PROCEDURE REQUIRES YOU TO BE UNDER THE VEHICLE.
- MAKE SURE THAT THE IGNITION SWITCH IS ALWAYS IN THE OFF POSITION, UNLESS OTHERWISE REQUIRED BY THE PROCEDURE.
- SET THE PARKING BRAKE WHEN WORKING ON THE VEHICLE. IF YOU HAVE AN AUTOMATIC TRANSMISSION, SET IN PARK UNLESS INSTRUCTED OTHERWISE FOR A SPECIFIC OPERATION. IF YOU HAVE A MANUAL TRANSMISSION, IT SHOULD BE IN REVERSE (ENGINE OFF) OR NEUTRAL (ENGINE ON) UNLESS INSTRUCTED OTHERWISE FOR A SPECIFIC OPERATION. PLACE WOOD BLOCKS (4" X 4" OR LARGER) AGAINST THE FRONT AND REAR SURFACES OF THE TIRES TO HELP PREVENT THE VEHICLE FROM MOVING.
- OPERATE THE ENGINE ONLY IN A WELL-VENTILATED AREA TO AVOID THE DANGER OF CARBON MONOXIDE POISONING.
- KEEP YOURSELF AND YOUR CLOTHING AWAY FROM MOVING PARTS WHEN THE ENGINE IS RUNNING, ESPECIALLY THE DRIVE BELTS.
- TO PREVENT SERIOUS BURNS, AVOID CONTACT WITH HOT METAL PARTS SUCH AS THE RADIATOR, EXHAUST MANIFOLD, TAIL PIPE, THREE-WAY CATALYTIC CONVERTER AND MUFFLER.
- DO NOT SMOKE WHILE WORKING ON A VEHICLE.

TO AVOID INJURY, ALWAYS REMOVE RINGS, WATCHES, LOOSE HANGING JEWELRY AND LOOSE CLOTHING BEFORE WORKING ON A VEHICLE.

BEFORE WORKING UNDER THE HOOD, KEEP HANDS AND OTHER OBJECTS CLEAR OF THE ENGINE!

**BUY IT NOW!**

**Click Here To Order**



GROUP

# GENERAL INFORMATION

# 1

SECTION TITLE	PAGE
Identification Codes .....	100-01-1
Jacking and Lifting .....	100-02-1
Noise, Vibration and Harshness .....	100-04-1

## SECTION 100-01 Identification Codes

VEHICLE APPLICATION: F-150/F-250

CONTENTS	PAGE
<b>DESCRIPTION AND OPERATION</b>	
Identification Codes .....	100-01-2

**100% SATISFACTION GUARANTEED**

**BUY IT NOW!**

**Click Here To Order**

PayPal American Express Discover MasterCard VISA

## DESCRIPTION AND OPERATION

### Identification Codes

The vehicle identification number (VIN) is a seventeen-digit combination of letters and numbers. The VIN is stamped on a metal tab riveted on the instrument panel top upper left of the dash. The VIN number is also found on the vehicle certification (VC) label.

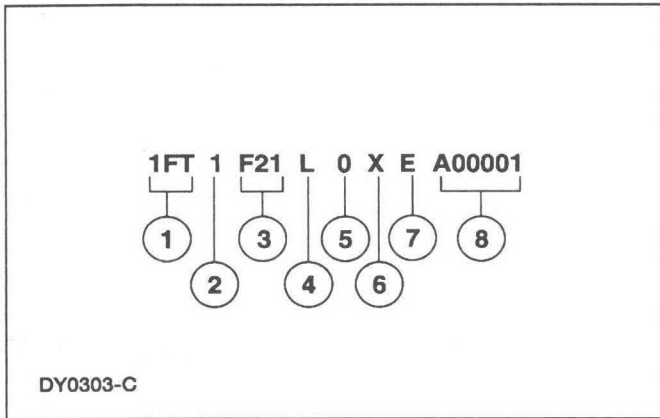

Item	Description
1	World manufacturer identifier
2	Brake type and gross vehicle weight rating (GVWR)
3	Vehicle line, series, body type
4	Engine type
5	Check digit
6	Model year
7	Assembly plant
8	Production sequence number

### Vehicle Identification Number

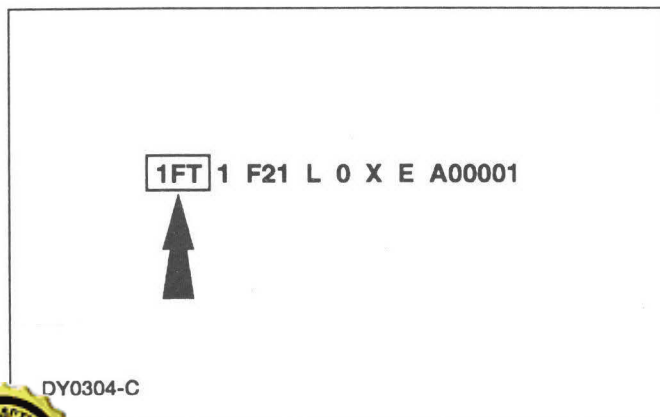

The first three vehicle identification number (VIN) positions are the world manufacturer code.

- 1FM — Ford Motor Company, USA, multi-purpose vehicle
- 1FT — Ford Motor Company, USA, truck, completed vehicle
- 1FD — Ford Motor Company, USA, incomplete vehicle
- 1FC — Ford Motor Company, USA, basic (stripped) chassis
- 1FB — Ford Motor Company, USA, bus
- 1FF — Ford Motor Company, USA, motor vehicle equipment without engine/powertrain (Glider)
- 1MH — Mercury, USA, incomplete vehicle
- 2FM — Ford Motor Company, Canada, multi-purpose vehicle
- 2FT — Ford Motor Company, Canada, truck, completed vehicle
- 2FD — Ford Motor Company, Canada, incomplete vehicle
- 2FC — Ford Motor Company, Canada, basic (stripped) chassis
- 2FB — Ford Motor Company, Canada, bus
- 2FF — Ford Motor Company, Canada, motor vehicle equipment without engine/powertrain (Glider)
- 2MH — Mercury, Canada, incomplete vehicle
- 3FB — Ford Motor Company, Mexico, bus
- 3FC — Ford Motor Company, Mexico, basic (stripped) chassis
- 3FE — Ford Motor Company, Mexico, incomplete vehicle
- 3FM — Ford Motor Company, Mexico, multi-purpose vehicle
- 3FT — Ford Motor Company, Mexico, truck, completed vehicle
- 4M2 — Mercury, USA, multi-purpose vehicle

**100% SATISFACTION GUARANTEED**

**BUY IT NOW!**

**Click Here To Order**

**DESCRIPTION AND OPERATION (Continued)**

- 4M3 — Mercury, USA, incomplete vehicle
- 4M4 — Mercury, USA, truck, completed vehicle
- 5LM — Lincoln, USA, multi-purpose vehicle

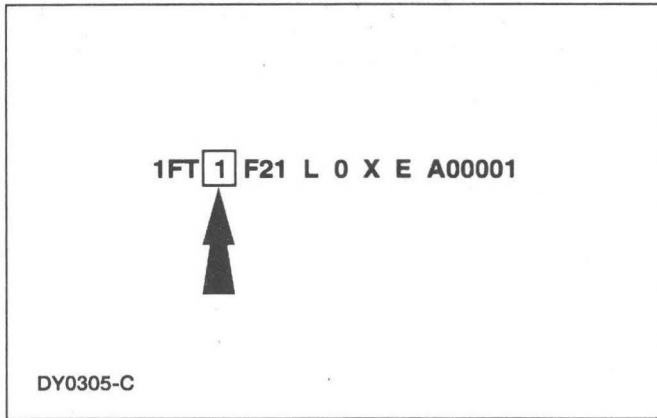

The fourth VIN position is the vehicle brake type and GVW code (all vehicles use hydraulic brakes).

- 0 — 8,550 pounds, F-250 over 8,500 pounds GVWR, Regular Cab, single rear wheels
- 1 — 8,800 pounds, F-250 over 8,500 pounds GVWR, Regular Cab, SuperCab, Crew Cab, single rear wheels
- 2 — 9,700 pounds, F-350 Regular Cab, SuperCab, Crew Cab (with California emissions), single rear wheels
- 3 — 9,900 pounds, F-350 Regular Cab, SuperCab, Crew Cab (without California emissions), single rear wheels
- 4 — 11,000 pounds, F-350 Regular Cab, SuperCab, Crew Cab (with California emissions), dual rear wheels
- 5 — 11,200 pounds, F-350 Regular Cab, SuperCab, Crew Cab (without California emissions), dual rear wheels
- 6 — 12,500 pounds, F-350 Regular Cab, SuperCab, Crew Cab, dual rear wheels
- 7 — 15,000 pounds, F-450 Regular Cab, SuperCab, Crew Cab, dual rear wheels
- 8 — 17,500 pounds, F-550 Regular Cab, SuperCab, Crew Cab, dual rear wheels
- 9 — 19,000 pounds, F-550 Regular Cab, SuperCab, Crew Cab, dual rear wheels
- F — 6,050 pounds, F-Series under 8,500 pounds GVWR, Regular Cab, SuperCab
- H — 6,250 pounds, F-Series under 8,500 pounds GVWR, Regular Cab, SuperCab
- J — 6,300 pounds, F-Series under 8,500 pounds GVWR, Regular Cab, SuperCab
- K — 6,500 pounds, F-250 under 8,500 pounds GVWR, Regular Cab, SuperCab
- 3 — 6,600 pounds, F-250 under 8,500 pounds GVWR
- Z — 5,001-6,000 pounds, F-Series under 8,500 pounds, Villager with second generation air bags, Ranger with second generation air bags, Windstar with second generation air bags
- R — 6,001-7,000 pounds, F-Series under 8,500 pounds with second generation air bags
- P — 7,001-8,000 pounds, F-Series under 8,500 pounds, Expedition/Navigator with second generation air bags
- 3 — 6,700 pounds, Expedition, 4x2, 4.6L engine
- 4 — 6,880 pounds, Expedition, 4x4, 4.6L engine
- 7 — 7,000 pounds, Expedition/Navigator (4x2, 5.4L engine), Econoline Club Wagon
- 1 — 7,200 pounds, Expedition/Navigator, 4x4, 5.4L engine
- D — 15,200 pounds, F53 Recreational Stripped Chassis (Motorhome)
- F — 15,500 pounds, F53 Recreational Stripped Chassis (Motorhome)
- D — Windstar, regular air bags with side air bags
- E — 18,000 pounds, F53 Recreational Stripped Chassis (Motorhome)
- R — 20,500 pounds, F53 Recreational Stripped Chassis (Motorhome)
- P — 8,700 pounds, Econoline Club Wagon
- 5 — 9,300 pounds, Econoline Club Wagon
- 4 — 9,100 pounds, Econoline Club Wagon (requires 5.4L engine)
- Q — 9,600 pounds, Econoline RV Cutaway (single rear wheels), Commercial Cutaway
- 2 — 10,700 pounds, Econoline RV Cutaway (dual rear wheels)
- Y — 11,500 pounds, Econoline RV Cutaway (dual rear wheels)



**BUY IT NOW!**

**Click Here To Order**



**DESCRIPTION AND OPERATION (Continued)**

- Y — 4,001- 5,000 pounds, Ranger with second generation air bags
- 6 — 14,050 pounds, Econoline RV Cutaway (dual rear wheels), Econoline Commercial Cutaway
- C — 14,000 pounds, Econoline RV Cutaway, (dual rear wheels), California, Commercial Cutaway, California
- 1 — 10,000 pounds, Econoline Commercial Cutaway (dual rear wheels, school bus)
- 2 — 10,700 pounds, Econoline Commercial Cutaway (dual rear wheels)
- 3 — 11,500 pounds, Econoline E-350 Commercial Cutaway
- 3 — 8,550 pounds, Econoline E-250 Commercial Cutaway
- B — 8,540 pounds, S24 bi-fuel van (Econoline)
- U — 9,600 pounds, Econoline Stripped Chassis (single rear wheels)
- W — 10,000 pounds, Econoline Stripped Chassis (dual rear wheels)
- Z — 11,000 pounds, Econoline Stripped Chassis (dual rear wheels)
- 3 — 8,600 pounds, Econoline Stripped Chassis (single rear wheels)
- 1 — 5,100 - 6000 pounds, Villager
- 1 — 4,320 pounds, Ranger 4x2 Regular Cab
- 2 — 4,720 pounds, Ranger 4x2 Regular Cab
- 3 — 4,360 pounds, Ranger 4x2 Regular Cab
- 5 — 4,880 pounds, Ranger 4x2 Regular Cab
- J — 5,260 pounds, Ranger 4x2 Regular Cab
- D — 5,400 pounds, Ranger 4x2 Regular Cab
- 9 — 4,540 pounds, Ranger 4x2 SuperCab
- 7 — 4,760 pounds, Ranger 4x2 SuperCab
- B — 4,900 pounds, Ranger 4x2 SuperCab
- X — 4,760 pounds, Ranger 4x4 Regular Cab
- W — 4,980 pounds, Ranger 4x4 Regular Cab
- L — 4,820 pounds, Ranger 4x4 Regular Cab
- G — 5,020 pounds, Ranger 4x4 Regular Cab
- K — 4,940 pounds, Ranger 4x4 SuperCab
- — 5,080 pounds, Ranger 4x4 SuperCab
- M — 5,200 pounds, Windstar (Wagon)
- L — 5,240 pounds, Windstar (Wagon)
- P — 5,260 pounds, Windstar (Wagon)
- S — 5,280 pounds, Windstar (Wagon)
- N — 5,320 pounds, Windstar (Wagon)
- R — 5,340 pounds, Windstar (Wagon)
- T — 5,360 pounds, Windstar (Wagon)
- U — 5,420 pounds, Windstar (Wagon)
- W — 5,500 pounds, Windstar (Wagon)
- X — 5,520 pounds, Windstar (Wagon)
- Y — 5,560 pounds, Windstar (Wagon)
- Z — 5,660 pounds, Windstar (Wagon)

1FT 1 **F21** L 0 X E A00001



DY0306-C

Positions 5 through 7 indicate vehicle line, series and body type.

- F20 — F-250 Regular Cab, 4x2 (single rear wheels), over 8,500 pounds GVWR
- F21 — F-250 Regular Cab, 4x4 (single rear wheels), over 8,500 pounds GVWR
- X20 — F-250 SuperCab, 4x2 (single rear wheels), over 8,500 pounds GVWR
- X21 — F-250 SuperCab, 4x4 (single rear wheels), over 8,500 pounds GVWR
- W20 — F-250 Crew Cab, 4x2 (single rear wheels), over 8,500 pounds GVWR
- W21 — F-250 Crew Cab, 4x4 (single rear wheels), over 8,500 pounds GVWR
- F30 — F-350 Regular Cab, 4x2 (single rear wheels), over 8,500 pounds GVWR
- F31 — F-350 Regular Cab, 4x4 (single rear wheels), over 8,500 pounds GVWR
- X30 — F-350 SuperCab, 4x2 (single rear wheels), over 8,500 pounds GVWR



**BUY IT NOW!**

**Click Here To Order**

PayPal

Discover  
Cards

DISCOVER  
NOWUS

MasterCard

VISA

**DESCRIPTION AND OPERATION (Continued)**

- X31 — F-350 SuperCab, 4x4 (single rear wheels), over 8,500 pounds GVWR
- W30 — F-350 Crew Cab, 4x2 (single rear wheels), over 8,500 pounds GVWR
- W31 — F-350 Crew Cab, 4x4 (single rear wheels), over 8,500 pounds GVWR
- F32 — F-350 Regular Cab, 4x2 (dual rear wheels), over 8,500 pounds GVWR
- F33 — F-350 Regular Cab, 4x4 (dual rear wheels), over 8,500 pounds GVWR
- X32 — F-350 SuperCab, 4x2 (dual rear wheels), over 8,500 pounds GVWR
- X33 — F-350 SuperCab, 4x4 (dual rear wheels), over 8,500 pounds GVWR
- W32 — F-350 Crew Cab, 4x2 (dual rear wheels), over 8,500 pounds GVWR
- W33 — F-350 Crew Cab, 4x4 (dual rear wheels), over 8,500 pounds GVWR
- F34 — F-350 Chassis Cab (Regular Cab), 4x2 (single rear wheels), over 8,500 pounds GVWR
- F35 — F-350 Chassis Cab (Regular Cab), 4x4 (single rear wheels), over 8,500 pounds GVWR
- X34 — F-350 Chassis Cab (SuperCab), 4x2 (single rear wheels), over 8,500 pounds GVWR
- X35 — F-350 Chassis Cab (SuperCab), 4x4 (single rear wheels), over 8,500 pounds GVWR
- W34 — F-350 Chassis Cab (Crew Cab), 4x2 (single rear wheels), over 8,500 pounds GVWR
- W35 — F-350 Chassis Cab (Crew Cab), 4x4 (single rear wheels), over 8,500 pounds GVWR
- F36 — F-350 Chassis Cab (Regular Cab), 4x2 (dual rear wheels), over 8,500 pounds GVWR
- F37 — F-350 Chassis Cab (Regular Cab), 4x4 (dual rear wheels), over 8,500 pounds GVWR
- X36 — F-350 Chassis Cab (SuperCab), 4x2 (dual rear wheels), over 8,500 pounds GVWR
- X37 — F-350 Chassis Cab (SuperCab), 4x4 (dual rear wheels), over 8,500 pounds GVWR
- W36 — F-350 Chassis Cab (Crew Cab), 4x2 (dual rear wheels), over 8,500 pounds GVWR
- W37 — F-350 Chassis Cab (Crew Cab), 4x4 (dual rear wheels), over 8,500 pounds GVWR
- F47 — F-450 Chassis Cab (Regular Cab), 4x4 (dual rear wheels), over 8,500 pounds GVWR
- W46 — F-450 Chassis Cab (Crew Cab), 4x2 (dual rear wheels), over 8,500 pounds GVWR
- W47 — F-450 Chassis Cab (Crew Cab), 4x4 (dual rear wheels), over 8,500 pounds GVWR
- F56 — F-550 Chassis Cab (Regular Cab), 4x2 (dual rear wheels), over 8,500 pounds GVWR
- F57 — F-550 Chassis Cab (Regular Cab), 4x4 (dual rear wheels), over 8,500 pounds GVWR
- W56 — F-550 Chassis Cab (Crew Cab), 4x2 (dual rear wheels), over 8,500 pounds GVWR
- W57 — F-550 Chassis Cab (Crew Cab), 4x4 (dual rear wheels), over 8,500 pounds GVWR
- F53 — Recreational Stripped Chassis (Motorhome)
- F07 — F-150 Regular Cab, 4x2 (Flareside), under 8,500 pounds GVWR
- F08 — F-150 Regular Cab, 4x4 (Flareside), under 8,500 pounds GVWR
- F17 — F-150 Regular Cab, 4x2 (Styleside), under 8,500 pounds GVWR
- F18 — F-150 Regular Cab, 4x4 (Styleside), under 8,500 pounds GVWR
- F27 — F-250 Regular Cab, 4x2 (Styleside), under 8,500 pounds GVWR
- F28 — F-250 Regular Cab, 4x4 (Styleside), under 8,500 pounds GVWR
- X07 — F-150 SuperCab, 4x2 (Flareside), under 8,500 pounds GVWR
- X08 — F-150 SuperCab, 4x4 (Flareside), under 8,500 pounds GVWR
- X17 — F-150 SuperCab, 4x2 (Styleside), under 8,500 pounds GVWR
- X18 — F-150 SuperCab, 4x4 (Styleside), under 8,500 pounds GVWR
- X27 — F-250 SuperCab, 4x2 (Styleside), under 8,500 pounds GVWR
- X28 — F-250 SuperCab, 4x4 (Styleside), under 8,500 pounds GVWR
- U17 — Expedition, 4x2
- U27 — Navigator, 4x2
- U18 — Expedition, 4x4
- U28 — Navigator, 4x4



**BUY IT NOW!**

**Click Here To Order**



**DESCRIPTION AND OPERATION (Continued)**

- E11 — Econoline Club Wagon
- E31 — Econoline Club Wagon (Heavy Duty)
- S31 — Econoline Club Wagon (Super Club Wagon)
- E14 — Econoline E-150 (Cargo Van)
- E24 — Econoline E-250 (Cargo Van)
- E27 — Econoline E-250 (Commercial Cutaway)
- E29 — Econoline E-250 (Commercial Basic)
- E30 — Econoline E-350 (RV Cutaway)
- E34 — Econoline E-350 (Cargo Van)
- E37 — Econoline E-350 (Commercial Cutaway)
- E39 — Econoline E-350 (Commercial Basic)
- S24 — Econoline E-250 (Super Van)
- S34 — Econoline E-350 (Super Van)
- E40 — Econoline E-450 (RV Cutaway)
- E47 — Econoline E-450 (Commercial Cutaway)
- V11 — Villager
- R08 — Ranger, 4x2 Regular Cab, Electric Vehicle
- R10 — Ranger, 4x2, Regular Cab
- R11 — Ranger, 4x4, Regular Cab
- R14 — Ranger, 4x2, SuperCab
- R15 — Ranger, 4x4, SuperCab
- A54 — Windstar, Van
- A51 — Windstar, LX, Wagon
- A52 — Windstar, SE, Wagon
- A53 — Windstar, SEL, Wagon
- A55 — Windstar, EC-Low, Wagon
- A56 — Windstar, EC-High, Wagon

The eighth VIN position is the engine displacement and number of cylinders.

- S — 6.8L, SOHC, EFI, V10, Gas, F-Series over 8,500 pounds GVWR, F53 Recreational Stripped Chassis (Motorhome), Econoline
- F — 7.3L, OHV, DI Turbo, V8, Diesel, F-Series over 8,500 pounds GVWR, Econoline
- 2 — 4.2L, OHV, EFI, V6, Gas, F-Series under 8,500 pounds GVWR, Econoline
- W — 4.6L, Modular SOHC, EFI, V8, Gas, F-Series under 8,500 pounds GVWR, Expedition/Navigator
- 6 — 4.6L, Modular SOHC, EFI, V8, Gas, F-Series under 8,500 pounds GVWR, Expedition/Navigator, Econoline
- M — 5.4L, SOHC, Natural Gas, F-Series under 8,500 pounds GVWR, Expedition/Navigator, Econoline
- Z — 5.4L, Bi-Fuel (NGV/Propane), F-Series under 8,500 pounds GVWR, Econoline
- 3 — 5.4L, 2V, SOHC, SFI, V8, Gas, F-Series under 8,500 pounds GVWR
- L — 5.4L, 2V, SOHC, EFI, V8, Gas, Expedition/Navigator, Econoline
- A — 5.4L, 4V, SOHC, EFI, V8, Gas, F-Series, Expedition/Navigator
- T — 3.3L, SOHC, V6, Gas, Villager
- C — 2.5L, SOHC, four cylinder, Gas, Ranger
- U — 3.0L, V6, Gas, Ranger, Windstar
- V — 3.0L, V6, Flex-Fuel, Ranger
- X — 4.0L, V6, Gas, Ranger
- 7 — 336V, 75 HP, Electric, Ranger
- 4 — 3.8L, OHV, EFI, V6 Gas, Windstar

1FT1F21 **L** 0 X E A00001



DY0307-C



**BUY IT NOW!**

**Click Here To Order**



## DESCRIPTION AND OPERATION (Continued)

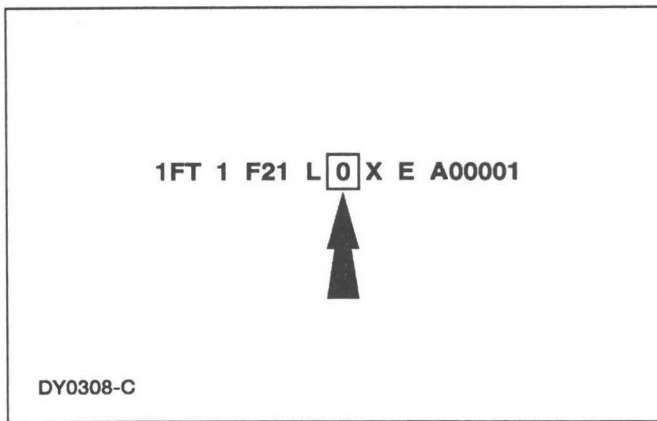

The ninth VIN position is a check digit.

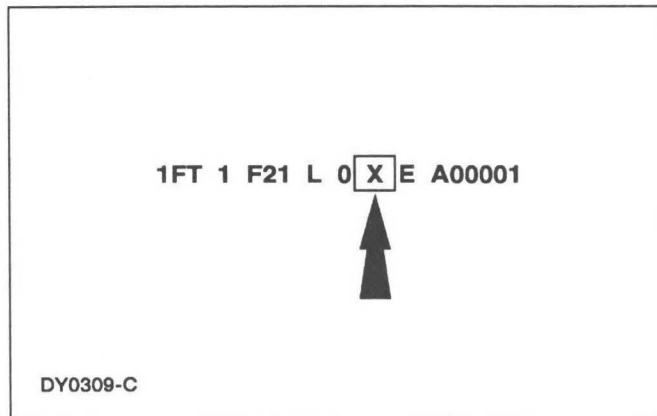

The tenth VIN position is the model year code.

- X — 1999

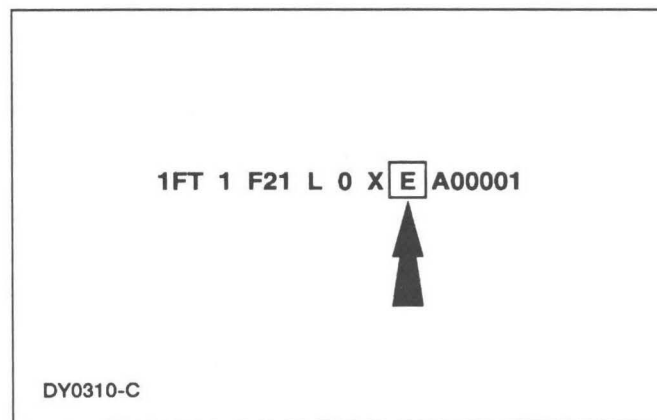

The eleventh VIN position is the assembly plant code.

- L — Michigan Truck (Wayne, Michigan)
- S — Allen Park (Allen Park, Michigan)
- H — Lorain (Lorain, Ohio)
- C — Ontario Truck (Oakville, Ontario)
- E — Kentucky Truck (Jefferson County, Kentucky)
- K — Kansas City (Claycomo, Missouri)
- N — Norfolk (Norfolk, Virginia)
- U — Louisville (Louisville, Kentucky)
- Z — St. Louis (Hazlewood, Missouri)
- P — Twin Cities (St. Paul, Minnesota)
- T — Edison (Edison, New Jersey)
- J — IMMSA (Monterrey, Mexico)
- D — Ohio Truck (Avon Lake, Ohio)
- B — Oakville (Oakville, Ontario)
- M — Cuautitlan (Cuautitlan, Mexico)

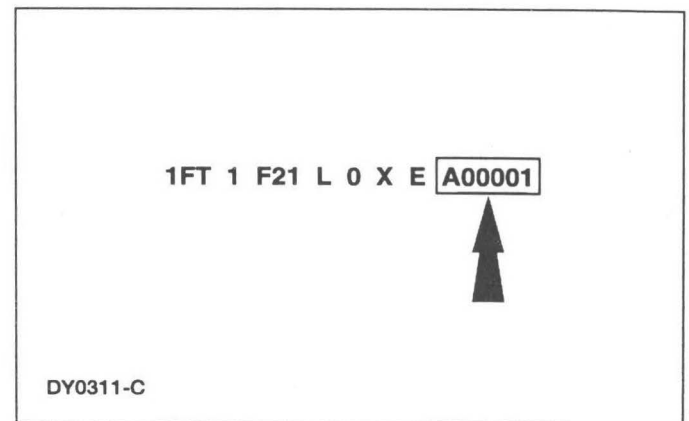

The last six VIN positions are an alphanumeric code for the vehicle build sequence. This is also the vehicle serial and warranty number.

- A00001-E99999 — Ford Division
- J00001-L99999 — Lincoln-Mercury Division

**100% SATISFACTION GUARANTEED**

**BUY IT NOW!**

**Click Here To Order**

**DESCRIPTION AND OPERATION (Continued)**

**Vehicle Certification (VC) Label**

MFD. BY FORD MOTOR CO. IN U.S.A.  
 DATE: XXXXX GVWR: XXXXXXXXXXXXXXXX  
 FRONT GAWR: XXXXXXXX REAR GAWR: XXXXXXXX  
 XXXXXXXX WITH XXXXXXXX WITH  
 XXXXXXXXXXXX TIRES XXXXXXXXXXXX TIRES  
 XXXXXXXX RIMS XXXXXXXX RIMS  
 AT XXXX kPa/XXX PSI COLD AT XXXX kPa/XXX PSI COLD  
 XXXX

THIS VEHICLE CONFORMS TO ALL APPLICABLE FEDERAL MOTOR VEHICLE SAFETY STANDARDS IN EFFECT ON THE DATE OF MANUFACTURE SHOWN ABOVE.  
 VIN: XXXXXXXXXXXXXXXXXXXX  
 TYPE: XXXXXXXXXXXXXXXXXXXX

EXT PNT: XXXXXXXX XXXXXXXX | RC: XX | DSO: XXXX  
 WB | BRK | INT | TR | TP/PS | R | AXLE | TR | SPR  
 XXX X XX XXX X XX X XXXX

4 5 6 7 8 9 10 11 3

DY0168-B

Item	Description
1	Exterior paint code
2	Region code
3	Domestic special order code
4	Wheel base code
5	Brake code
6	Interior trim code
7	Tape/paint pinstripe code
8	Radio code
9	Axle code
10	Transmission code
11	Spring code

The vehicle certification (VC) label contains the manufacturer name, the month and year of manufacture, the certification statement, and the VIN. It also includes gross vehicle weight ratings (GVWR).

**Vehicle Certification (VC) Label — Canada (Typical)**

MFD. BY FORD MOTOR CO. IN U.S.A.  
 DATE: XXXXX GVWR/PNBV: XXXXXXXXXXXXXXXXXXXX  
 FRONT GAWR / REAR GAWR  
 PNBE AV PNBE AR  
 XXXXXXXX XXXXXXXX  
 XXXXXXXX XXXXXXXX  
 WITH/AVEC TIRES/PNEUS  
 XXXXXXXXXXXX / XXXXXXXXXXXX  
 XXXXXXXX RIMS/JANTES XXXXXXXX  
 AT/A kPa/PSI/LPC XXXXX/XXX COLD/A FROID XXXX/XXX  
 XXXX/JUMELÉES

VIN: XXXXXXXXXXXXXXXXXXXX  
 TYPE: XXXXXXXXXXXXXXXXXXXX

EXT PNT: XXXXXXXX XXXXXXXX | RC: XX | DSO: XXXX  
 WB | BRK | INT | TR | TP/PS | R | AXLE | TR | SPR  
 XXX X XX XXX X XX X XXXX

DY0195-A

**Vehicle Certification (VC) Label — Mexico (Typical)**

MFD. BY FORD MOTOR COMPANY  
 DATE: XXXXX GVWR: XXXXXXXXXXXXXXXX  
 FRONT GAWR: XXXXXXXX REAR GAWR: XXXXXXXX  
 XXXXXXXX WITH XXXXXXXX WITH  
 XXXXXXXXXXXX TIRES XXXXXXXXXXXX TIRES  
 XXXXXXXX RIMS XXXXXXXX RIMS  
 AT XXXX kPa/XXX PSI COLD AT XXXX kPa/XXX PSI COLD  
 XXXX

THIS VEHICLE CONFORMS TO ALL APPLICABLE FEDERAL MOTOR VEHICLE SAFETY, BUMPER, AND THEFT PREVENTION STANDARDS IN EFFECT ON THE DATE OF MANUFACTURE SHOWN ABOVE.  
 VIN: XXXXXXXXXXXXXXXXXXXX  
 TYPE: XXXXXXXXXXXXXXXXXXXX

EXT PNT: XXXXXXXX XXXXXXXX | RC: XX | DSO: XXXX  
 WB | BRK | INT | TR | TP/PS | R | AXLE | TR | SPR  
 XXX X XX XXX X XX X XXXX

MADE IN MEXICO

DY0261-A

**BUY IT NOW!**  
 Click Here To Order



**DESCRIPTION AND OPERATION (Continued)**

- 61 — 3.73, non-limited slip, F-350, dual rear wheels
- 62 — 4.10, non-limited slip, F-350, dual rear wheels
- 63 — 4.30, non-limited slip, F-350, dual rear wheels
- 66 — 4.56, non-limited slip, F-350, dual rear wheels
- F1 — 3.73, limited slip, F-350, dual rear wheels
- F2 — 4.10, limited slip, F-350, dual rear wheels
- F3 — 4.30, limited slip, F-350, dual rear wheels
- F6 — 4.56, limited slip, F-350, dual rear wheels
- 81 — 3.73, non-limited slip, F-350 narrow frame, dual rear wheels
- 82 — 4.10, non-limited slip, F-350 narrow frame, Econoline, dual rear wheels
- 83 — 4.30, non-limited slip, F-350 narrow frame, dual rear wheels
- 86 — 4.56, non-limited slip, F-350 narrow frame, dual rear wheels
- 88 — 4.88, non-limited slip, F-350 narrow frame, dual rear wheels
- E1 — 3.73, limited slip, F-350 narrow frame, dual rear wheels
- E2 — 4.10, limited slip, F-350 narrow frame, dual rear wheels, E-350
- EW — 4.10, limited slip, F-350 narrow frame, dual rear wheels
- E3 — 4.30, limited slip, F-350 narrow frame, dual rear wheels
- E6 — 4.56, limited slip, F-350 narrow frame, dual rear wheels
- 78 — 4.88, non-limited slip, F-450 Chassis Cab, dual rear wheels
- 75 — 5.38, non-limited slip, F-450 Chassis Cab, dual rear wheels
- G8 — 4.88, limited slip, F-450 Chassis Cab, dual rear wheels
- G5 — 5.38, limited slip, F-450 Chassis Cab, dual rear wheels
- GW — 4.10, limited slip, F-450 Chassis Cab, dual rear wheels
- 98 — 4.88, non-limited slip, F-550 Chassis Cab, dual rear wheels
- 95 — 5.38, non-limited slip, F-550 Chassis Cab, dual rear wheels
- K5 — 5.38, limited slip, F-550 Chassis Cab, dual rear wheels
- KW — 4.10, limited slip, F-550 Chassis Cab, dual rear wheels
- 17 — 3.31, non-limited slip, Expedition/Navigator, Econoline
- 18 — 3.08, non-limited slip, F-150
- 19 — 3.55, non-limited slip, F-150, F-250 under 8,500 pounds GVWR, Expedition, Econoline
- 26 — 3.73, non-limited slip, F-150, F-250 under 8,500 pounds GVWR
- 27 — 3.31, non-limited slip, F-150, F-250 under 8,500 pounds GVWR
- 28 — 3.73, non-limited slip, F-150, F-250 under 8,500 pounds GVWR
- H6 — 3.73, limited slip, Expedition/Navigator
- H7 — 3.31, limited slip, Expedition, Econoline
- H9 — 3.55, limited slip, F-150, F-250 under 8,500 pounds GVWR, Expedition, Econoline
- B6 — 3.73, limited slip, F-150, F-250 under 8,500 pounds GVWR
- 75 — Dana 80, 11,000 pounds GVWR, F53 Recreational Stripped Chassis, Motorhome
- 95 — Dana 135, 13,500 pounds GVWR, F53 Recreational Stripped Chassis, Motorhome
- 24 — 3.73, non-limited slip, Econoline
- B4 — 3.73, limited slip, Econoline
- 35 — 4.09, non-limited slip, Econoline
- C5 — 4.09, limited slip, Econoline
- 34 — 3.73, non-limited slip, Econoline, single rear wheels
- C4 — 3.73, non-limited slip, Econoline, single rear wheels
- 39 — 3.55, non-limited slip, Econoline, single rear wheels
- C9 — 3.55, limited slip, Econoline, single rear wheels
- 52 — 4.10, non-limited slip, Econoline
- 56 — 4.10, non-limited slip, Econoline
- E6 — 4.10, limited slip, Econoline
- 81 — 4.63, non-limited slip, Econoline
- 19 — 3.86, Villager
- KA — No ratio, Ranger, Electric



**BUY IT NOW!**

**Click Here To Order**



**DESCRIPTION AND OPERATION (Continued)**

- 84 — 3.45, non-limited slip, Ranger
- 86 — 3.73, non-limited slip, Ranger
- 87 — 4.10, non-limited slip, Ranger
- 89 — 4.56, non-limited slip, Ranger
- F6 — 3.73, limited slip, Ranger
- F7 — 4.10, limited slip, Ranger
- 95 — 3.55, non-limited slip, Ranger
- R5 — 3.55, limited slip, Ranger
- 96 — 3.73, non-limited slip, Ranger
- R6 — 3.73, limited slip, Ranger
- 15 — 3.56, non-limited slip, Windstar
- 16 — 3.98, non-limited slip, Windstar

**Transmission Codes**

- B — Four-speed manual, T199 (Mexico), F-Series over 8,500 pounds GVWR
- W — Five-speed manual, heavy duty overdrive (Dana ZF), F-Series over 8,500 pounds GVWR
- E — Four-speed automatic overdrive (4R100), F-Series
- 6 — Six-speed manual Z/F (M6HD-6), F-Series over 8,500 pounds GVWR
- M — Five-speed manual overdrive (Mazda M5R2-C), F-Series under 8,500 pounds GVWR
- U — Four-speed automatic (AODE-W/4R70W), F-Series under 8,500 pounds GVWR, Econoline
- 7 — Four-speed automatic (NAAO 4R100), F-Series under 8,500 pounds GVWR
- U — Automatic (AOD) Expedition/Navigator (4.6L engine)
- E — Automatic (4R100) Expedition/Navigator (5.4L engine), F53 Recreational Stripped Chassis (Motorhome), Econoline
- P — Four-speed automatic overdrive, Villager
- T — Four-speed automatic (4R44E), Ranger
- D — Five-speed automatic (5R55E), Ranger
- M — Five-speed manual (M5R1), Ranger
- H — One-speed, Ranger, Electric
- L — Four-speed automatic overdrive (AX4S), Windstar

**Spring Codes**

The following lists available spring codes.

**Front Springs**

- Base part number — 5310 (RH/LH), F-Series, Expedition/Navigator, Econoline, Ranger, Windstar
- A — Ranger 4x2, Windstar, Econoline
- C — Ranger 4x2, Windstar, Econoline
- D — Ranger 4x2, Windstar, Econoline
- E — Ranger 4x2, Windstar, Econoline
- F — Econoline
- G — Ranger 4x2, Econoline
- H — Ranger 4x2, Econoline
- J — Ranger 4x2, Econoline
- K — Econoline
- L — Econoline
- M — Econoline
- N — Econoline
- P — Econoline
- R — Econoline
- S — Econoline
- T — Econoline
- U — Econoline
- V — Econoline
- Z — Econoline
- 2 — Ranger 4x2
- 3 — Ranger 4x2
- B — Windstar, Econoline

**Torsion Bars**

- Base part number — 5B326 (RH), F-Series under 8,500 pounds GVWR, Expedition/Navigator
- Base part number — 5B327 (LH), F-Series under 8,500 pounds GVWR, Expedition/Navigator, Ranger
- B — Ranger 4x4 and Electric Vehicle
- F — Ranger 4x4 and Electric Vehicle
- 1 — Ranger 4x4 and Electric Vehicle



**BUY IT NOW!**

**Click Here To Order**



**DESCRIPTION AND OPERATION (Continued)****Load Leveling Suspension**

- P — Expedition/Navigator (4x4), F-Series under 8,500 pounds GVWR

**Load Leveling Suspension — Rear**

- L — Expedition/Navigator (4x2)

**Rear Springs**

- Base part number — 5560, F-Series, Econoline, Ranger
- Base part number — 5534, Windstar
- 6 — 5534, Expedition/Navigator, Econoline
- 5 — 5534, Expedition/Navigator
- 7 — 5534, Expedition/Navigator, Econoline
- 8 — 5A891, Expedition/Navigator
- 9 — 5A891, Expedition/Navigator
- C — 5588, auxiliary rear spring, F-Series over 8,500 pounds GVWR, Econoline
- D — 5588, auxiliary rear spring, F-Series over 8,500 pounds GVWR
- 3 — Ranger
- 7 — Ranger
- C — Ranger, Windstar
- E — Ranger, Windstar
- K — Ranger
- N — Ranger, Econoline
- D — Windstar
- F — Windstar (Van)
- P — Econoline
- R — Econoline
- S — Econoline
- G — Econoline

**Interior Trim Codes**

The following lists the interior trim and interior color codes.

**Interior Trim**

- V — Vinyl bench, F-Series
- K — Knitted vinyl bench, F-Series over 8,500 pounds GVWR

- F — Cloth captains chairs with console, F-Series under 8,500 pounds GVWR
- M — Full bench (Mexico only), F-Series over 8,500 pounds GVWR
- M — Cloth 60/40, F-Series under 8,500 pounds GVWR
- M — Cloth 60/40, F-Series under 8,500 pounds GVWR (Mexico)
- A — Vinyl full bench, F-Series under 8,500 pounds GVWR
- H — Leather captains chairs with console, F-Series under 8,500 pounds GVWR
- E — Leather 40/60, F-Series under 8,500 pounds GVWR
- 3 — Cloth 40/20/40, F-Series over 8,500 pounds GVWR
- 8 — Leather 40/20/40, F-Series over 8,500 pounds GVWR
- 2 — Cloth captains chairs, F-Series over 8,500 pounds GVWR
- 4 — Leather captains chairs, F-Series over 8,500 pounds GVWR
- 5 — Leather quad captains chairs, F-Series over 8,500 pounds GVWR
- M — Manitou cloth split bench, Expedition/Navigator
- F — Manitou cloth captains chairs, Expedition/Navigator
- S — Vinyl captains chairs, Expedition/Navigator
- 1 — Leather captains chairs, Expedition/Navigator
- K — Leather S/S captains chairs, Expedition/Navigator
- A — Hampton vinyl bucket seats, Econoline
- E — Camden cloth captains chairs, Econoline
- C — Stockton cloth bucket seats, Econoline
- F — Kirk cloth captains chairs, Econoline
- X — No trim available (seats not included), Econoline
- 5 — Nomad cloth, Villager (GS)
- 6 — Deco cloth, Villager (LS)
- M — Top grain leather, Villager (LS)
- 6 — Mono grain leather, Villager (LS)
- H — Simulated split vinyl bench, Ranger

**BUY IT NOW!****Click Here To Order**

F-Series over



**DESCRIPTION AND OPERATION (Continued)**

- E — Cirrus cloth 60/40 split bench, Ranger
- G — Triad luxury sport bucket seats, Ranger
- G — Cloth — cedar, Windstar (LX)
- H — Cloth — cedar, Windstar (SE)
- 2 — Nudo leather, Windstar

**Interior Color Codes**

- X — Medium Prairie Tan, F-Series, Expedition/Navigator, Ranger
- 2 — Medium Graphite, F-Series, Expedition/Navigator, Econoline, Ranger, Windstar
- D — Denim Blue, F-Series over 8,500 pounds GVWR, Econoline
- T — Dark Graphite, F-Series under 8,500 pounds GVWR, Expedition/Navigator, Ranger
- R — Dark Denim, F-Series under 8,500 pounds GVWR, Windstar
- N — Medium Parchment, Econoline
- K — Portland, Villager
- C — Mink, Villager
- D — Cactus, Villager
- H — Medium Parchment, Windstar

**Tape Stripe Codes**

- S — Silver Metallic/Dark Violet/Bright Green, F-Series over 8,500 pounds GVWR (XLT)
- V — Prairie Tan/Dark Violet/Burnt Orange, F-Series over 8,500 pounds GVWR (Lariat)
- W — Cordovan, F-Series over 8,500 pounds GVWR (Super Crew Appearance Package)
- X — Ebony/Dark Violet/Burnt Orange, F-Series over 8,500 pounds GVWR (Lariat)
- D — Silver Metallic/Medium Platinum Metallic, F-Series under 8,500 pounds GVWR (XL and XLT)

- E — Light Prairie Tan/Medium Palomino, F-Series under 8,500 pounds GVWR (XL and XLT)
- G — Deep Crystal Blue/Light Portofino, F-Series under 8,500 pounds GVWR (XL and XLT)
- H — Silver Metallic/Deep Crystal Blue, F-Series under 8,500 pounds GVWR (XL and XLT)
- J — Light Prairie Tan/Medium Palomino, F-Series under 8,500 pounds GVWR (XL and XLT)
- K — Deep Crystal Blue/Gold Metallic, F-Series under 8,500 pounds GVWR (XL and XLT)
- L — Deep Crystal Blue (upper), Medium Dark Woodrose (lower), F-Series under 8,500 pounds GVWR (Lariat)
- M — Jewel Green/Gold Metallic (upper and lower), F-Series under 8,500 pounds GVWR (Lariat)
- N — Toreador/Gold Metallic (upper and lower), F-Series under 8,500 pounds GVWR (Lariat)
- B — Blue Sport, F-Series under 8,500 pounds GVWR (STX Package)
- X — Tapestripes deleted, F-Series under 8,500 pounds GVWR
- A — Silver/Red/Titanium (Econoline Chateau Appearance Package)
- P — Platinum, Ranger 4x4, XLT, Off Road
- S — Silver, Ranger 4x4, XLT, Off Road Package
- B — Blue/Dark Blue Ranger, XLT (less Off Road Package)
- C — Copper/Gold, Ranger, XLT (less Off Road)
- G — Green/Blue, Ranger, XLT, (less Off Road)
- R — Burnt Orange, Ranger
- L — Pastel Blue, Ranger

**BUY IT NOW!****Click Here To Order**

# SECTION 100-02 Jacking and Lifting

VEHICLE APPLICATION: F-150/F-250

CONTENTS	PAGE
<b>DESCRIPTION AND OPERATION</b>	
Jacking .....	100-02-2
Lifting .....	100-02-3
Lifting Points — Twin Post Hoist .....	100-02-3



**BUY IT NOW!**  
**Click Here To Order**



## DESCRIPTION AND OPERATION

### Jacking

**⚠ WARNING:** The electrical power to the air suspension system must be shut down prior to hoisting, jacking or towing an air suspension vehicle. This can be accomplished by turning off the air suspension switch located in the RH kick panel area. Failure to do so may result in unexpected inflation or deflation of the air springs which may result in shifting of the vehicle during these operations.

**⚠ WARNING:** Do not run the engine when jacking the vehicle. The wheels contacting the ground could cause the vehicle to move.

**⚠ WARNING:** Support the vehicle prior to performing any procedure requiring the vehicle to be jacked off the ground.

**⚠ WARNING:** Make sure the jack and jack stands are properly located to prevent the vehicle from falling.

**⚠ WARNING:** Wheel chocks should be used to prevent the vehicle from rolling and falling off the jack.

**⚠ CAUTION:** Never use a halfshaft as a lifting point.

#### Jacking Points — Front, 4x4

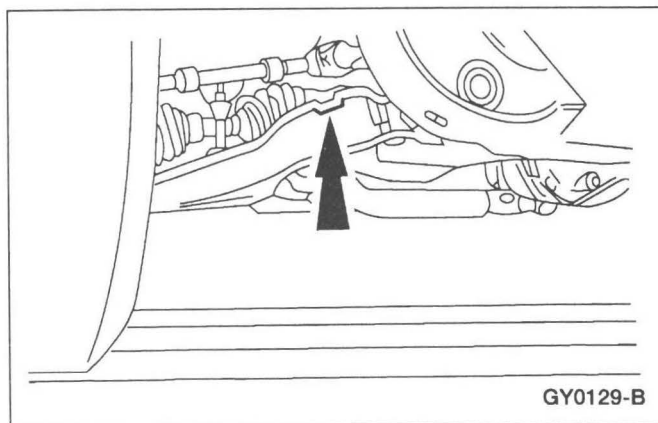

The jacking point is a raised boss located on the front suspension lower arm (3079).

#### Jacking Points — Front, 4x2

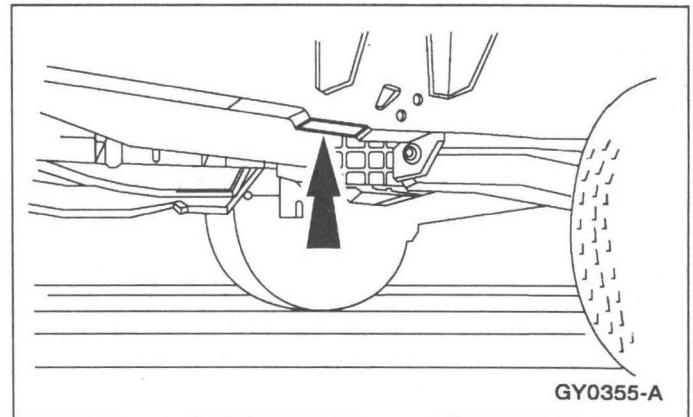

The jacking point is a flat portion on the frame indicated by the arrow cut out. The jacking point is located behind the front tire and wheel assembly.

#### Jacking Points — Rear

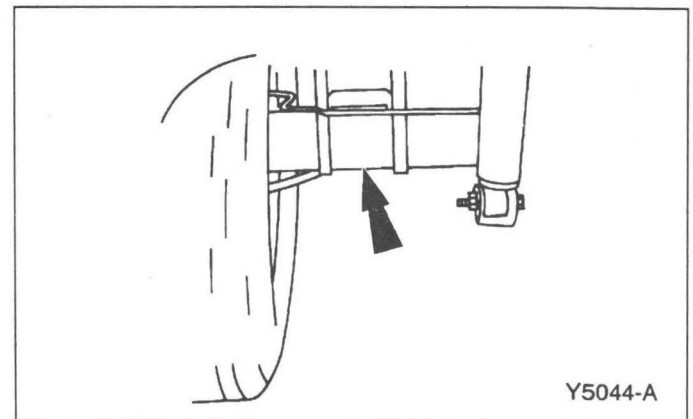

**⚠ CAUTION:** Never use the differential housing as a lifting point.

The rear jacking points are located on the rear axle (4001).

**100% SATISFACTION GUARANTEED**

**BUY IT NOW!**

**Click Here To Order**

PayPal | American Express | Discover | MasterCard | VISA

**DESCRIPTION AND OPERATION (Continued)****Lifting**

 **WARNING:** The electrical power to the air suspension system must be shut off prior to hoisting, jacking or towing an air suspension vehicle. This can be accomplished by turning off the air suspension switch located in the RH kick panel area. Failure to do so may result in unexpected inflation or deflation of the air spring which may result in shifting of the vehicle during these procedures.

 **CAUTION:** Damage to suspension, exhaust and steering linkage components may occur if care is not exercised when positioning the hoist adapters prior to lifting the vehicle.

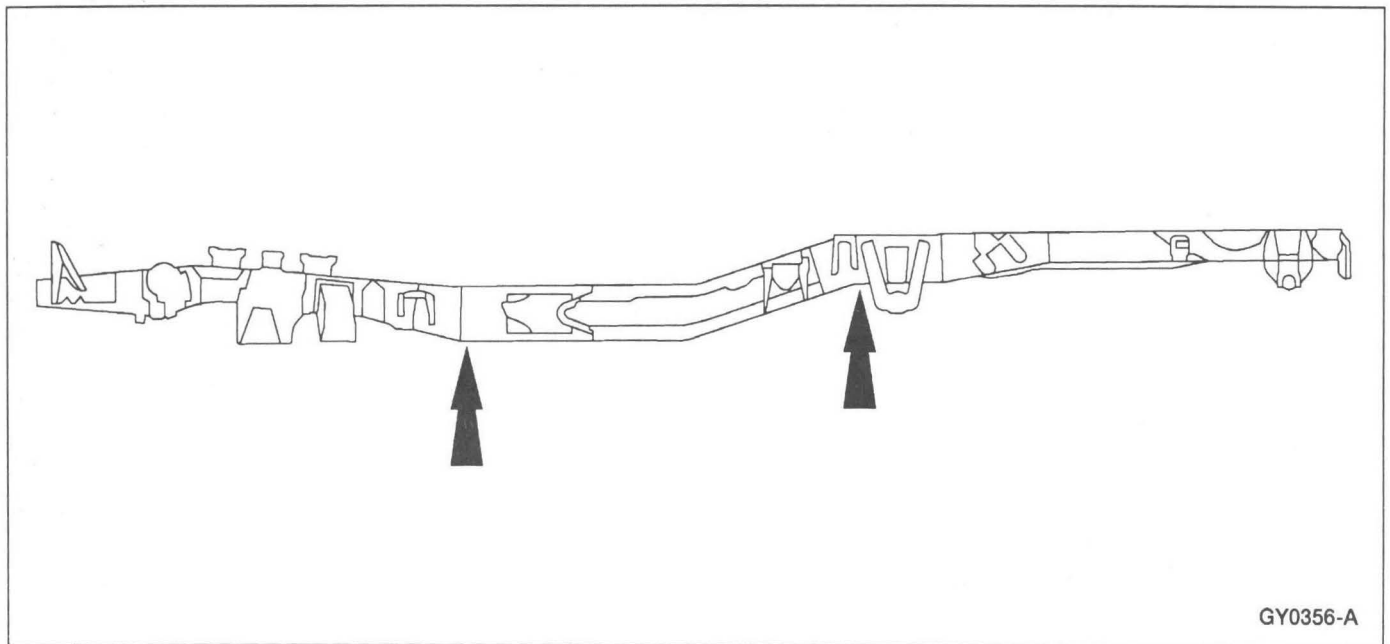
**Lifting Points — Twin Post Hoist**

Locate the front hoist adapters and rear hoist adapters (top of frame arc) as indicated.

**BUY IT NOW!****Click Here To Order**

# SECTION 100-04 Noise, Vibration and Harshness

VEHICLE APPLICATION: F-150/F-250

CONTENTS	PAGE
<b>DESCRIPTION AND OPERATION</b>	
Noise, Vibration and Harshness (NVH) .....	100-04-2
Definitions .....	100-04-2
Diagnostic Theory .....	100-04-2
Glossary of Terms .....	100-04-2
Normal Noise, Vibration and Harshness .....	100-04-2
<b>DIAGNOSIS AND TESTING</b>	
Noise, Vibration and Harshness (NVH) .....	100-04-5
Diagnostic Procedure .....	100-04-6
Accessories Mounting Inspection .....	100-04-14
Axle Inspection .....	100-04-14
Drive Belt Inspection .....	100-04-14
Driveshaft Inspection .....	100-04-14
Driveshaft U-Joint Inspection .....	100-04-14
Exhaust System Inspection .....	100-04-15
Halfshaft Inspection .....	100-04-15
Hoist Test .....	100-04-13
Noise Diagnostic Procedure .....	100-04-8
Road Test .....	100-04-9
Tire/Wheel Inspection .....	100-04-15
Transfer Case Inspection .....	100-04-15
Inspection and Verification .....	100-04-5
How to Use the Diagnostic Procedure .....	100-04-5
Pinpoint Tests .....	100-04-18
Symptom Chart .....	100-04-16
<b>GENERAL PROCEDURES</b>	
Exhaust System Neutralizing .....	100-04-30
Powertrain/Drivetrain Mount Neutralizing .....	100-04-29



**BUY IT NOW!**

**Click Here To Order** 

PayPal

MasterCard

DISCOVER  
NEWUS

MasterCard

VISA

## DESCRIPTION AND OPERATION

### Noise, Vibration and Harshness (NVH)

#### Definitions

Noise is any unwanted sound, usually unpleasant in nature. Possible sources of noise are:

- the engine.
- the engine accessories.
- the intake and exhaust systems.
- the driveline.
- electric motors and pumps.
- the wind.
- mechanical pumps.
- the road surface.

Vibration is an unwanted periodic motion of a body or medium. It may be felt, heard, or seen. Possible sources of vibration include the:

- tires.
- engine.
- engine accessories.
- suspension.
- driveline.
- exhaust system.

Harshness refers to the ride quality and is very subjective. Reference to the previous conditions is usually the only way to identify harshness as a symptom.

#### Normal Noise, Vibration and Harshness

All internal combustion engines and drivelines produce some noise and vibration; operating in a real world environment adds noise and vibration that are not subject to control. Vibration isolators, mufflers and dampers are used to reduce these to acceptable levels.

A driver who is unfamiliar with a vehicle may think that some sounds are abnormal when actually the sounds are normal for the vehicle type. For example, four-wheel drive vehicles and vehicles with Traction-Lok® differentials produce noise when driven on hard surfaces that does not result on two-wheel drive vehicles or on surfaces where wheel slip can occur.

As a technician, it is very important to be familiar with vehicle features and know how they relate to NVH concerns and their diagnosis. If, for example, the vehicle has automatic overdrive, it is important to test drive in and out of overdrive mode.

#### Diagnostic Theory

The shortest route to an accurate diagnosis results from:

- system knowledge, including comparison with a known good system.
- system history, including repair history and usage patterns.
- condition history, especially any relationship to repairs or sudden change.
- knowledge of probable causes.
- using a systematic diagnostic method that divides the system into related areas.

The diagnosis and correction of noise, vibration and harshness concerns requires:

- a road test to determine the exact nature of the concern.
- an analysis of the possible causes.
- testing to verify the cause.
- repairing any concerns found.
- a road test to make sure the concern has been corrected or brought back to within a normal range.

#### Glossary of Terms

##### Acceleration

The act or process of increasing speed. Acceleration occurs at light, medium, or wide-open throttle (WOT) conditions.

##### Light Acceleration

An increase in speed at less than half throttle.

##### Medium Acceleration

An increase in speed at half to nearly full throttle.

##### WOT Acceleration

An increase in speed at wide-open throttle.

##### Ambient Temperature

The surrounding or prevailing temperature.

**SATISFACTORY 100% GUARANTEED**

**BUY IT NOW!**

**Click Here To Order**

PayPal Discover MasterCard VISA

**DESCRIPTION AND OPERATION (Continued)****Articulation**

The relative movement of attached components.

**Belt Chirp**

A high-pitched short-duration noise usually caused by belt misalignment.

**Belt Squeal**

A high-pitched long-duration noise usually caused by belt slippage.

**Boom**

A low-frequency (sometimes cycling) noise, often felt as well as heard.

**Bound Up**

A stressed isolation mount or component that transmits vibration instead of dampening or isolating it.

**Brakes Applied**

The use of the brakes to keep the vehicle from moving.

**Camber**

The angle of the wheel in relation to the true vertical as measured looking from the front of the vehicle.

Camber is positive when the wheel angle is offset so that the top of the wheel is positioned away from the vehicle.

**Caster**

The angle of the steering knuckle in relation to the true vertical as measured looking from the side of the vehicle.

**Chuckle**

The noise that occurs during the coast driving phase, usually caused by excessive clearance due to differential gear wear or by a damaged tooth on the coast side of the final drive ring gear.

**Clunk**

A short-duration, dull sound, usually associated with the transmission engaging in reverse or drive, or heard upon initial drive-away.

**Coast/Deceleration**

The vehicle is in motion and the transmission is engaged, but no pressure is applied to the accelerator pedal. Speed control, if equipped, is disengaged.

**Coast/Neutral Coast**

The vehicle is in motion with the transmission disengaged.

**Controlled Rear Suspension Height**

The height that a designated vehicle element must be at when driveline angle measurements are made.

**Coupling Shaft**

The front shaft in a two-piece driveline system.

**CPS**

Cycles per second.

**Cruise**

Constant speed on level ground; neither accelerating nor decelerating.

**Deceleration**

Slowing of the vehicle by releasing the accelerator pedal, but without using the brakes.

**Drive Engine Run-Up Test**

The operation of the engine through the normal rpm range with the vehicle standing still and the transmission engaged. This test is used for vibration checks.

**Driveline Angles**

The differences of alignment between the transmission output shaft, the driveshaft (4602), and the rear axle pinion centerline.

**Driveshaft**

The shaft that transmits power to the axle input shaft (pinion shaft). In a two-piece driveline, it is the rearmost shaft.

**Dynamic Balance**

The equal distribution of weight on each side of the centerline, so that when the wheel and tire assembly spins there is no tendency for the assembly to move from side to side (wobble). Dynamically unbalanced wheel and tire assemblies can cause wheel shimmy. Refer to Section 204-04 for the appropriate balancing procedures.

**Drivetrain**

All power transmitting components from the engine to the wheels; includes the clutch or torque converter, the transmission, the driveline, and the drive axle.

**Drivetrain Damper**

A weight attached to the engine, the transmission, the transfer case, or the axle. It is tuned by weight and placement to absorb vibration.

**SATISFACTION 100% GUARANTEED**

**BUY IT NOW!**

**Click Here To Order**

PayPal American Express Discover MasterCard VISA

## DESCRIPTION AND OPERATION (Continued)

### Dynamic Balance

The equal distribution of weight on each side of the centerline, so that when the wheel and tire assembly spins there is no tendency for the assembly to move from side to side (wobble). Dynamically unbalanced wheel and tire assemblies can cause wheel shimmy. Refer to Section 204-04 for the appropriate balancing procedures.

### Engine Imbalance

An exaggerated engine movement or vibration that directly increases in frequency as the engine speed increases.

### Engine Shake

A condition in which an engine's mass center is not concentric to the rotation center.

### Engine Misfire

When ignition in one or more cylinders does not occur or occurs at the wrong time.

### Flexible Coupling

A flexible joint in the exhaust pipe located between the catalytic converter and muffler, designed to eliminate binding conditions in the exhaust system and eliminate exhaust NVH.

### Float

A drive mode on the dividing line between cruise and coast where the throttle setting matches the engine speed with the road speed.

### Gravelly Feel

A grinding or growl in a component, similar to the feel experienced when driving on gravel.

### Harshness

A firmer-than-usual response of a component.

### Hose Clamp

A screw-type circular clamp.

### Hz

Hertz; a frequency of one cycle per second.

### Imbalance

Out of balance; heavier on one side than the other. In a rotating component, imbalance often causes vibration.

### Inboard

Toward the vehicle centerline.

### In-Phase

The in-line relationship between the forward coupling of the drive shaft and the driveshaft centering socket yoke of

### Isolate

To separate from the influence of other components.

### Knock

The noise caused by gear tooth damage on the drive side of the final drive ring gear, and also by the relative motion of components that are supported by bearings.

### Neutral Engine Run-Up Test

The operation of the engine through the normal rpm range with the vehicle standing still and the transmission disengaged. This test is used to identify engine related vibrations.

### Neutralize/Normalize

To relieve stress from possible bound-up components.

### NVH

Noise, vibration and harshness.

### Outboard

Away from the centerline of the vehicle.

### Pinion Shaft

The input shaft in a driving axle that is usually a part of the smaller driving or input hypoid gear of a ring and pinion gearset.

### Pumping Feel

A slow pulsing movement.

### Radial/Lateral

Radial is in the plane of rotation; lateral is at 90 degrees to the plane of rotation.

### Ring Gear

The large, circular, driven gear in a ring and pinion gearset.

### Road Test

The operation of the vehicle under conditions intended to produce the concern under investigation.

### Runout

Out of round or wobble.

### Shake

Low frequency vibration, usually with visible movement.

### Slip Yoke/Slip Spline

The driveshaft coupling that allows length changes to occur while the suspension articulates and while the driveshaft rotates.



**BUY IT NOW!**

**Click Here To Order**



## DESCRIPTION AND OPERATION (Continued)

### Static Balance

The equal distribution of weight around the wheel. Statically unbalanced wheel and tire assemblies can cause a bouncing action called wheel tramp. This condition will eventually cause uneven tire wear. Refer to Section 204-04 for the appropriate balancing procedures.

### Tip-In Moan

A light moaning noise heard during light vehicle acceleration, usually between 40-100 km/h (25-65 mph).

### TIR

Total indicated runout.

### Tire Deflection

The change in tire diameter in the area where the tire contacts the ground.

### Tire Force Vibration

A tire vibration caused by variations in the construction of the tire that is noticeable when the tire rotates against the pavement. This condition may be present on perfectly round tires because of variations in the inner tire construction.

### Tire Flat Spots

A condition commonly caused by letting the vehicle stand when the tires are warm. It can be corrected by driving the vehicle until the tires are warm. This concern is more likely to occur with N, V and Z-speed rated tires.

Tire wear caused by wheel-locked skids.

### Two-Plane Balance

Radial and lateral balance.

### Vibration

An unwanted periodic motion of a body or medium. It can be felt, heard or seen.

## DIAGNOSIS AND TESTING

### Noise, Vibration and Harshness (NVH)

#### Special Tool(s)

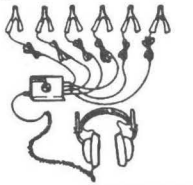
 <p>ST2048-A</p>	<p>Chassis EAR 107-R2102 or Equivalent</p>
---	--

#### Inspection and Verification

This section provides a working knowledge of the process of diagnosing noise, vibration and harshness (NVH) conditions. The topics are based on the description of the condition. For example, if the condition is a shake that occurs at high speed, the most likely place to start is under High-Speed Shake in the symptom chart. The road test procedure will help you to sort the conditions into categories and distinguish a vibration from a shake. It also provides quick checks to help pinpoint or eliminate a cause.

#### How to Use the Diagnostic Procedure

Begin with the customer interview. Use the Glossary of Terms to find the descriptive name of conditions not encountered before. After naming it, identify the condition by performing a road test. Then, locate the proper diagnosis. Remember, by beginning at that point, most other systems in the vehicle have been eliminated; when the proper method of diagnosis is identified, the job is partly done. Follow the steps within the diagnostic procedure. Quick checks are described within the steps, while more involved procedures and adjustments are found in the General Procedures portion of this section. Always follow each step exactly and make notes along the way to recall important findings later.

**100% SATISFACTORY GUARANTEED**

**BUY IT NOW!**

**Click Here To Order**



## DIAGNOSIS AND TESTING (Continued)

### Diagnostic Procedure

#### 1: Customer Interview

It is important to interview the customer. Customer feedback can supply information that could be helpful in diagnosing the concern. Ask questions like:

- When is the concern present (at idle or while driving)?
- Where does the concern appear to be coming from?
- How long has the concern been there? Has it steadily become worse?
- When did the concern start?
- Does the concern change with engine speed or with vehicle speed?

Use the customer concern evaluation form, shown following the last step of this procedure, to record customer concerns.

#### 2: Duplicate the Noise Concern

Is the noise heard while bouncing the bumper of the vehicle, driving over rough road surfaces, braking, when driving, or while parked?

Typically, front underbody noise is heard while doing the static bounce test (bouncing the bumper or the vehicle). If the noise can not be duplicated with the static bounce test, or during low speed turning maneuvers, it is most likely not suspension related.

#### 3: Isolate the Noise Concern

If the noise can be duplicated by the static bounce test, one of the following methods will help to locate the problem while doing the static bounce test.

- Use a stethoscope or ChassisEAR to determine the area of the chassis that the noise appears to be coming from.

- Place your hand on the coil spring, radius arm, or stabilizer bar. This method is sometimes misleading as the vibrations may carry from one suspension component to another.

#### 4: Inspecting the Vehicle

While inspecting the vehicle in the general area of the source of the noise, look for the following:

- loose fasteners
- worn/broken parts
- excessive dirt/rust accumulation
- signs of leaking fluid
- debris wrapped around the driveshaft, halfshaft or axle

#### 5: Repair of the Vehicle

Use the symptom chart to find which pinpoint test, actions or other section(s) to refer to. Also, check TSBs, OASIS/Hotline for recent techniques or known related systems concerns.

#### 6: Test Drive the Vehicle

Repeat the method used to duplicate the problem to verify that the noise has been repaired.

#### 7: Follow Up with the Customer

Follow up with the customer about two weeks after the repair is performed to ensure that the noise was correctly identified and repaired.

**SATISFACTION 100% GUARANTEED**

**BUY IT NOW!**

**Click Here To Order**

PayPal American Express Discover MasterCard VISA

**DIAGNOSIS AND TESTING (Continued)****Customer Concern Evaluation Form****CUSTOMER CONCERN EVALUATION****Initial Write-Up Questions:**

1. Did this condition exist when the vehicle was new?  
Yes   
No
2. How did the condition begin?  
Explain: \_\_\_\_\_
3. Is the problem heard, felt, or both?  
Heard   
Felt   
Both
4. On what type of road surface can the problem be demonstrated?  
Concrete   
Gravel   
Black Top   
Other \_\_\_\_\_
5. Is the problem temperature-dependent?  
Hot   
Cold   
Both Hot and Cold
6. Define the type of noise heard.  
Boom   
Buzz   
Click   
Clunk   
Gear   
Grind   
Hum   
Knock   
Moan   
Pop   
Rumble   
Scrape   
Snap
7. If the problem noise is boom, is it seat-dependent?  
Yes   
No
8. If the problem is vibration, where is it felt?  
Seat  Accelerator Pedal   
Steering Wheel  Hood/Fenders   
Instrument Panel  Rearview Mirror   
Floor

DF0394-B

**BUY IT NOW!****Click Here To Order**

PayPal



## DIAGNOSIS AND TESTING (Continued)

### Noise Diagnostic Procedure

#### Non-Axle Noise

There are some components, that when subject to certain conditions, can produce noise similar to axle noise and must be considered while performing a road test diagnosis. The seven most common are noise from the transmission, the exhaust system, the tires, roof racks, the power steering pump, the trim mouldings, and auxiliary fluid coolers.

Be sure that none of these components are the cause of the noise concern before proceeding with an axle teardown and diagnosis.

#### Noise Conditions

If noise is related to a specific component or system, refer to the appropriate workshop manual section for further diagnosis.

#### Vibration Conditions

Technically, vibration is a low- to high-frequency excitation, shaking or grounding condition, felt or heard, that is steady or variable in level and occurs during a portion of the total operating speed range. The types of vibrations that can be felt in the vehicle are divided into three groups:

- **NOTE:** Halfshafts are not balanced and do not contribute to rotational vibration disturbances.  
Vibrations of various unbalanced rotating parts of the vehicle.
- Body and frame vibrations excited by powertrain, wind, or road inputs.
- Tip-in moans or resonance vibrations from stressed engine, exhaust system mounts, or driveline flexing modes.

These vehicle vibrations can also be subdivided into those that occur at low speeds and those that are most noticeable at higher speeds. Since the line between lower and higher speed vibrations is not clear, there will be vibrations that overlap the two ranges.

Typical Low-Speed Vibrations (Less Than 72 km/h [45 mph]):

- exhaust vibration
- engine harshness/vibration
- driveline vibration due to improper driveline angles or bad U-joints

- take-off shudder (driveline concerns)
- brake roughness or harshness
- driveline roughness
- excessive wheel runout
- tire flat spots
- driveline slip-yoke or pinion flange
- components/material trapped between the body and the frame, the engine and the frame or the engine and the body
- automatic transmission clutch slippage

Typical High-Speed Vibrations (Above 72 km/h [45 mph]):

- axle and pinion flange runout
- driveshaft imbalance
- excessive tire-wheel and brake disc or drum assembly imbalance
- tire roughness due to high non-uniformity (force variation) or out-of-balance condition
- rear axle pinion gear pitch line runout
- excessive tire and wheel runout
- components/material trapped between the body and the frame, the engine and the frame, or the engine and the body
- worn suspension components
- front end accessory vibrations
- exhaust vibration

Harshness is the term commonly used to describe the ride quality concern of the vehicle. A hard ride or harshness is usually caused by the tires or suspension system, namely:

- components/material trapped between the body and the frame
- overinflated, wrong size, or wrong type of tire installed on the vehicle
- suspension insufficiently lubricated
- worn suspension components
- suspension components installed with preload on the pivot point, the bearings, and the bushings
- vehicles equipped with tires that are not specified by the manufacturer (different brand tires often give different ride qualities to the vehicle)
- bent, bound-up or worn shock absorbers or shock isolators



**BUY IT NOW!**

**Click Here To Order**



**DIAGNOSIS AND TESTING (Continued)**

- heavy-duty components installed on the vehicle
- air ride/load leveling suspension inoperative, damaged, deflated or improperly adjusted

Other harshness conditions that effect ride quality are summarized as follows:

- Vehicle bounce — the vertical motion of a vehicle on its suspension system, front, and rear in phase. A low frequency “float”; an intermediate frequency “kick.”
- Vehicle pitch — the out-of-phase vertical motion of the front and rear of the vehicle. A flat ride is considered the opposite of a pitch ride.
- Vehicle roll — the side-to-side rotation of the vehicle body about the front and the rear axles.

**Road Test**

Noise, vibration and harshness (NVH) diagnosis must start with the customer interview and be followed by a road test.

**NVH Diagnostic Locator**

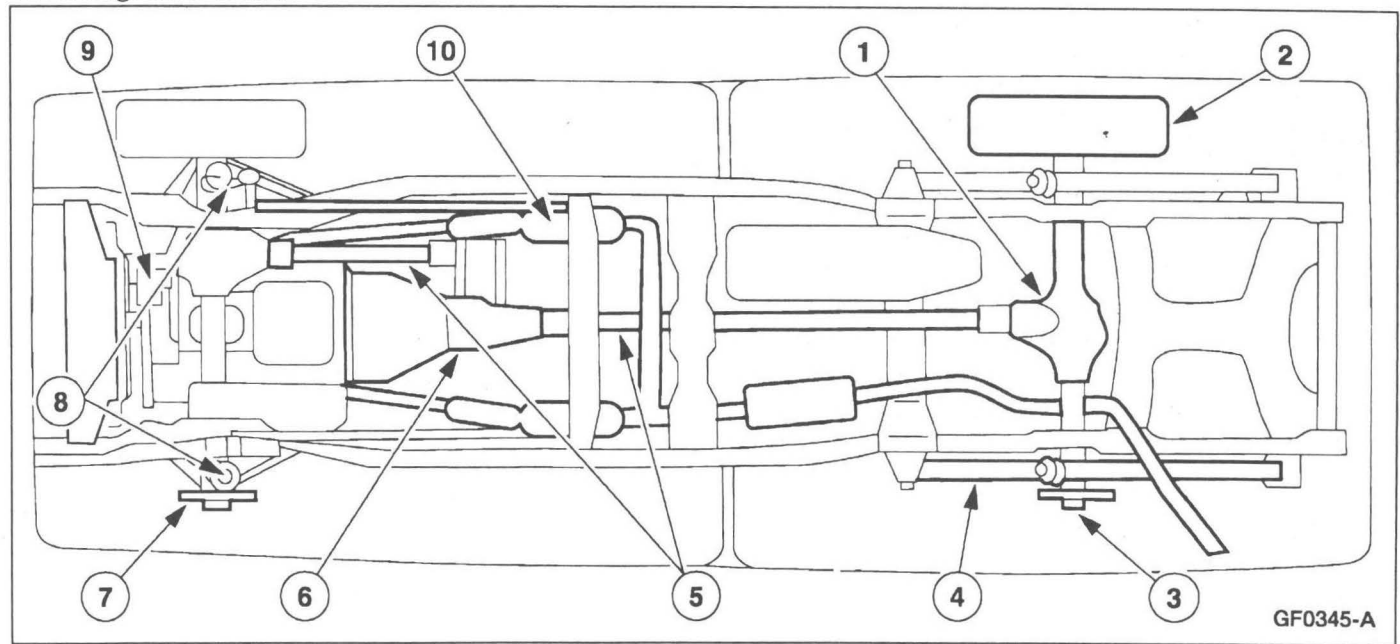

Item	Condition	Possible Source
1	Noise, Driveline Vibration	Drive Axle Bearing Roughness, Ring Gear Runout, Excessive Backlash Variation, Pinion Flange Runout, Driveshaft Runout, Pinion Runout
2	Noise, High-Speed Shake	Wheel and Tire Imbalance, Runout, Non-Uniformity, Inflation, Force Variations, Flat Spots
3	Noise, High-Speed Shake	Wheel Bearing Roughness, Axle Shaft End Play, Axle Flange Face, Pilot or Bolt Circle Runout, Brake Disc (Drum, if so equipped) Balance

NVH usually occurs in five areas:

- tires
- engine accessories
- suspension
- **NOTE:** A gear-driven unit will produce a certain amount of noise. Some noise audible at certain speeds or under various driving conditions is acceptable. Slight noise is not detrimental and must be considered normal.
- drivetrain
- body and interior trim panels

It is important that an NVH concern be isolated into its specific area as soon as possible. The easiest and quickest way to do this is to perform a road test.

**100% SATISFACTION GUARANTEED**

**BUY IT NOW!**

**Click Here To Order**

**DIAGNOSIS AND TESTING (Continued)**

Item	Condition	Possible Source
4	Noise, Harshness	Rear Suspension Wear, Damage, Misalignment, Binding, Worn/Hard Bushings
5	Vibration	Driveshaft Runout, Balance, Angle, U-Joint Seizure, Wear
6	Noise, Vibration	Transmission Gear Wear or Damage, Torque Converter Balance, Output Shaft Straightness, Transfer Case (4x4)
7	Noise, High-Speed Shake, Harshness	Wheel Bearing Roughness, Misadjustment, Wheel Hub Face, Pilot or Bolt Circle Runout, CV Joint Binding (4x4), Brake Disc Balance, Ball Joints
8	Noise, Harshness	Steering Intermediate Shaft, Poor Sealing of Components Passing from Interior to Exterior
9	Tip-In Moan, Boom, Vibration	Engine, Mounts, Accessories, Air Cleaner, Torque Converter, Belts Binding, Loose, Misaligned, Worn or Damaged
10	Tip-In Moan, Noise	Exhaust System Grounding, Binding, Bound Up Hangers, Damaged/Bent Components

1. Use the Vehicle Road Test Evaluation form shown following the last step of this procedure. Make notes on the backside of the form throughout the diagnostic routine.
2. **NOTE:** Do not make adjustments until a road test and a thorough visual inspection of the vehicle is performed. Do not change the tire pressure or the vehicle load. This may reduce the condition's intensity to a point at which it cannot be identified clearly. It may also inject a new condition into the concern, preventing proper diagnosis.  

Make a visual inspection as part of the preliminary diagnostic routine, writing down anything that does not look right. Note the tire pressures, but do not adjust them yet. Note leaking fluids, loose nuts/bolts, or bright spots where components are rubbing against each other. Check the cargo area for unusual loads.
3. Perform the neutral engine run-up (NERU) test. It identifies engine or exhaust-related vibrations and helps in sorting out vibrations that are found in the road test.
  - a. If the vehicle is equipped with a tachometer, it can be used. Otherwise, a tach must be connected.
  - b. Locate the vehicle away from other vehicles and walls which may reflect sound differently than a road.
  - c. Put the vehicle in N (neutral) or P (park), and do not set the parking brake or press on the   
 are not engaged in a
  - d. Run the engine rpm up from an idle to approximately 4000 rpm and note any moans, vibrations, noises, etc., and the rpm at which they occur. Sometimes it is possible to "tune in" on these conditions by running the rpm up and down to determine a precise rpm at which they occur; in other cases they will fall over a broad range of rpm. This establishes a baseline against which driving vibrations can be measured.
  - e. If you suspect that the exhaust system is vibrating, hang a ring of keys or something similar from the tailpipe and listen for the rattling of the keys as the engine is run up and down.
  - f. When conducting the road test, refer to the results of the NERU test to distinguish vibrations and noises caused by the engine from those caused by the transmission, the driveshaft (4602), or the axle. If a vibration or noise occurs at a particular speed, try operating in another gear at the same speed. This changes the engine rpm and helps to distinguish engine induced vibrations and noises. If it occurs at a particular rpm, use different gears to test at the same rpm at different road speeds.
4. Perform the drive engine run-up (DERU) test.





**BUY IT NOW!**

**Click Here To Order**



**DIAGNOSIS AND TESTING (Continued)**

 **WARNING:** Set both the parking brake and service brake and make sure to perform the test with enough space ahead of the vehicle to eliminate the possibility of an accident if the vehicle unintentionally lurches forward.

 **CAUTION:** Do not conduct this test for over 30 seconds, or without periodic driving or shifting to neutral to circulate transmission lubricant; otherwise the transmission will overheat causing severe damage to the automatic transmission.

Place the transmission selector lever in D (DRIVE) and run the engine rpm up and down between an idle and approximately 2000 rpm. Note the nature of any vibrations and noises and when these concerns occur in relation to engine rpm.

5. **NOTE:** The type of road and its surface condition are important factors in the road test. A smooth asphalt road that allows driving over a range of speeds is best. The brushed concrete road surface found on many expressways and the coarse aggregate sometimes found in concrete can mask many vehicle noises and make NVH diagnosis difficult.

Road test the vehicle and define the condition by reproducing it several times during the road test.

- a. A tachometer must be used.
- b. Note the fuel level. Some vehicles change in their response to various excitations when the fuel level changes.

- c. Try to duplicate the conditions with the customer present, particularly the speed and throttle operation.
  - d. Find the speed where the concern is most severe.
  - e. Accelerate gently through this speed to a few mph above it and then coast back down a few mph below it and note if the concern changes.
  - f. Repeat this procedure, if necessary, to get a feeling for the behavior. Then drive about five mph above the speed, put the transmission in NEUTRAL, and coast down. Note any change in behavior.
  - g. Try “floating” the driveline by backing off slightly on the throttle at the speed at which the condition occurs. The idea is to unload the axle gears and the universal joints as much as possible. If the concern does not change in all these modes of operation, the cause may be driveline imbalance since the imbalance is not changed by the throttle position.
6. Perform the road test quick checks as soon as the condition is reproduced. This will identify the proper method of diagnosis. Run through the quick checks more than once to make sure you are getting a usable result.

**BUY IT NOW!****Click Here To Order**

**DIAGNOSIS AND TESTING (Continued)****Road Test Form****VEHICLE ROAD TEST EVALUATION****Road Test Evaluations:**

1. Does the problem occur with engine, driveshaft, or wheel speed?
  - Engine
  - Driveshaft
  - Wheel
  
2. Is the problem road speed dependent? (Occurs at the same vehicle speed independent of transmission gear).
  - Yes
  - No
  
3. Is the problem engine speed dependent? (Occurs at the same engine rpm, independent of transmission gear).
  - Yes
  - No
  
4. If the problem is engine speed dependent, perform a neutral engine runup (NERU), and compare rpm's to road rpm's.
  - Same as NERU
  - Different than NERU
  
5. Is the problem drive mode dependent? (Occurs in drive, cruise, coast/float).
  - Drive  Speed \_\_\_\_\_
  - Cruise  Speed \_\_\_\_\_
  - Coast  Speed \_\_\_\_\_
  - Float  Speed \_\_\_\_\_
  
6. Is the problem acceleration rate dependent? (Light, medium or heavy throttle).
  - Light
  - Medium
  - Heavy
  
7. Does the problem occur from a stop?
  - Yes
  - No
  
8. Is the problem transmission gear dependent? (Occurs in overdrive, but not direct drive).
  - Yes
  - No
  
9. Does the problem occur on turns?
  - Yes
  - No
  
10. Does the problem only occur when going from reverse to drive or drive to reverse?
  - Yes
  - No

DE1351-B

**BUY IT NOW!****Click Here To Order**

## DIAGNOSIS AND TESTING (Continued)

### Road Test Quick Checks

1. 24-80 km/h (15-50 mph): With light acceleration, a moaning noise is heard and possibly a vibration is felt in the floorpan. It is usually worse at a particular engine speed and at a particular throttle setting during acceleration at that speed. It may also produce a moaning sound, depending on what component is causing it.

Refer to Tip-In Moan in the symptom chart.

2. 40-72 km/h (25-45 mph): With steady to heavy acceleration or deceleration, a rumble-type noise is heard. It is very intense during heavy acceleration or deceleration and very light during cruise or neutral coast. The vibration is hard to duplicate with vehicle supported on a hoist, since the wheels are coasting free.

Refer to Driveshaft Vibration in the symptom chart.

3. High Speed: With slow acceleration and deceleration or at constant speed, a shake is sometimes noticed in the steering wheel/column, seats, floorpan, trim panels or front end sheet metal. It is a low frequency vibration (around 9-15 cycles per second). It may increase when applying the brakes lightly.

Refer to High-Speed Shake in the symptom chart.

4. High Speed: A vibration is felt in the floorpan or seats, with no visible shake, but with an accompanying sound or rumble, buzz, hum, drone or booming noise.

It will exist in all drive modes, but may vary somewhat in acceleration, deceleration, float or coast modes. In some cases, the driveline vibration is eliminated in the float mode.

Refer to Driveshaft Vibration in the symptom chart.

5. Neutral Engine Run-Up: A vibration is felt whenever the engine reaches a particular rpm either with the vehicle in motion or while the vehicle is sitting still. It can be caused by any component from the fan back to the torque converter (7902) and by anything that turns at engine speed when the vehicle is stopped.

Refer to Engine Accessory Vibration in the symptom chart.

6. Noise and Vibration While Turning: Clicking, popping or grinding noises may be due to the following:
  - cut or damaged CV joint boot resulting in inadequate or contaminated lube fill in the CV joint
  - loose CV joint boot clamp
  - a component contacting the halfshaft assembly
  - worn, damaged or improperly installed wheel bearing
  - worn, contaminated or dry CV joint

### Hoist Test

 **WARNING: If only one drive wheel is allowed to rotate, the speed must be limited to a maximum speedometer reading of 55 km/h (34 mph) since the actual wheel speed will be twice that indicated on the speedometer. Exceeding a speed of 55 km/h (34 mph) or allowing the drive wheel to hang unsupported can result in tire disintegration/differential failure, which can cause serious personal injury/extensive vehicle damage.**

After a road test, it is sometimes useful to do a similar test on a hoist. (Use an axle hoist, not a frame hoist. An axle hoist will not change the driveline angles. If only a frame hoist is available, axle stands must be used.) Make sure the 4x4 selector is in the 2WD mode on a 4x4 vehicle.





**BUY IT NOW!**

**Click Here To Order**



## DIAGNOSIS AND TESTING (Continued)

1.  **WARNING:** The electrical power to the air suspension system must be shut off prior to hoisting, jacking or towing an air suspension vehicle. This can be accomplished by turning off the air suspension switch. Failure to do so can result in unexpected inflation or deflation of the air springs, which can result in shifting of the vehicle during these operations.

 **WARNING:** A vehicle equipped with a Traction-Lok® differential will always have both wheels driving. If only one wheel is raised off the floor and the rear axle is driven by the engine, the wheel on the floor could drive the vehicle off the stand or jack. Be sure both rear wheels are off the floor.

Elevate the rear wheels slightly. Check to make sure both wheels will turn.

2. Start the engine and place the transmission selector lever in DRIVE (D). Explore the speed range of interest using the drive/cruise/float tests; refer to Road Test in this section.
3. A coast down in NEUTRAL must also be conducted. If the vehicle is free of vibration when operating at a steady indicated speed and behaves very differently in DRIVE and coast, an axle concern is likely.

### Accessories Mounting Inspection

Inspect the drive belt accessories mounting brackets and hardware for loose fasteners or bad belt alignment; for additional information, refer to Section 303-05.

### Axle Inspection

 **WARNING:** The electrical power to the air suspension system must be shut off prior to hoisting, jacking or towing an air suspension vehicle. This can be accomplished by turning off the air suspension switch. Failure to do so can result in unexpected inflation or deflation of the air springs, which can result in shifting of the vehicle during these operations.

Check for low differential lubricant; for additional information, refer to Section 205-02A, Section 205-02B, Section 205-02C or Section 205-03. During

the rear axle may have a chattering noise (Traction-Lok® axles only). Slight chatter noise on driving is a normal, non-detrimental effect on

### Drive Belt Inspection

Inspect the drive belt (8620) and pulleys for wear or damage. The automatic tensioners have belt wear indicator marks. If the indicator mark is not between the MIN and MAX marks, the drive belt is worn or an incorrect drive belt is installed. With the engine idling, check for irregular motion of the drive belt; for additional information, refer to Section 303-05.

### Driveshaft Inspection

 **WARNING:** The electrical power to the air suspension system must be shut off prior to hoisting, jacking or towing an air suspension vehicle. This can be accomplished by turning off the air suspension switch. Failure to do so can result in unexpected inflation or deflation of the air springs, which can result in shifting of the vehicle during these operations.

Inspect the driveshaft for any undercoating, physical damage and missing balance weights. Check for index marks (yellow paint daub marks) on the rear of the driveshaft and the axle pinion flange. The paint daubs must be less than 22-1/2 degrees apart.

### Driveshaft U-Joint Inspection

 **WARNING:** The electrical power to the air suspension system must be shut off prior to hoisting, jacking or towing an air suspension vehicle. This can be accomplished by turning off the air suspension switch. Failure to do so can result in unexpected inflation or deflation of the air springs, which can result in shifting of the vehicle during these operations.

Place the vehicle on a frame hoist and rotate the driveshaft by hand. Check for rough operation or seized U-joints. Replace the U-joint if it shows signs of seizure, excessive wear, or improper seating; for additional information, refer to Section 205-01.



**BUY IT NOW!**

**Click Here To Order**



## DIAGNOSIS AND TESTING (Continued)

### Halfshaft Inspection

 **WARNING:** The electrical power to the air suspension system must be shut off prior to hoisting, jacking or towing an air suspension vehicle. This can be accomplished by turning off the air suspension switch. Failure to do so can result in unexpected inflation or deflation of the air springs, which can result in shifting of the vehicle during these operations.

**NOTE:** Constant velocity (CV) joints must not be replaced unless disassembly and inspection reveals unusual wear; for additional information, refer to Section 205-04.

**NOTE:** While inspecting the boots, watch for indentations (“dimples”) in the boot convolutions. Indentations must be removed.

- Inspect the boots for evidence of cracks, tears, or splits.
- Inspect the underbody for any indication of grease splatter near the boots’ outboard and inboard locations. This is an indication of boot/clamp damage.

### Exhaust System Inspection

 **WARNING:** The electrical power to the air suspension system must be shut off prior to hoisting, jacking or towing an air suspension vehicle. This can be accomplished by turning off the air suspension switch. Failure to do so can result in unexpected inflation or deflation of the air springs, which can result in shifting of the vehicle during these operations.

Raise the vehicle on a hoist and check for broken and loose clamps and brackets. Check for damaged and bent exhaust components and for exhaust components touching the body and the frame; for additional information, refer to Section 309-00.

### Tire/Wheel Inspection

 **WARNING:** The electrical power to the air suspension system must be shut off prior to hoisting, jacking or towing an air suspension vehicle. This can be accomplished by turning off the air suspension switch. Failure to do so can result in unexpected inflation or deflation of the air springs, which can result in shifting of the vehicle during these operations.

Inspect the tires and the wheels for wear and damage. Check the tires for cupping and flat spots. Verify that the correct tire size and wheel rim are used. If a tire/wheel is damaged, the suspension components can suffer misalignment, abnormal wear/damage that contribute to the tire/wheel damage; for additional information, refer to Section 204-00 or Section 204-04.

### Transfer Case Inspection

 **WARNING:** The electrical power to the air suspension system must be shut off prior to hoisting, jacking or towing an air suspension vehicle. This can be accomplished by turning off the air suspension switch. Failure to do so can result in unexpected inflation or deflation of the air springs, which can result in shifting of the vehicle during these operations.

Inspect the transfer case for proper operation; for additional information, refer to Section 308-07A or Section 308-07B.



**100% SATISFACTION GUARANTEED**

**BUY IT NOW!**

**Click Here To Order**

PayPal American Express Discover MasterCard VISA

**DIAGNOSIS AND TESTING (Continued)****Symptom Chart****Noise, Vibration and Harshness**

Condition	Possible Source	Action
<ul style="list-style-type: none"> <li>High-Speed Shake</li> </ul>	<ul style="list-style-type: none"> <li>Wheel hub or axle flange face/pilot/bolt circle runout.</li> <li>Tires/wheels.</li> <li>Wheel bearings.</li> <li>Suspension/steering linkage.</li> <li>Engine.</li> <li>Transmission.</li> <li>Brake discs/drums — imbalance.</li> </ul>	<ul style="list-style-type: none"> <li>GO to Pinpoint Test A.</li> <li>INSPECT for damage; REFER to Section 206-00.</li> </ul>
<ul style="list-style-type: none"> <li>Tip-In Moan</li> </ul>	<ul style="list-style-type: none"> <li>Air cleaner (ACL).</li> <li>Engine mounts.</li> <li>Exhaust.</li> </ul>	<ul style="list-style-type: none"> <li>GO to Pinpoint Test B.</li> </ul>
<ul style="list-style-type: none"> <li>Idle Boom/Shake/Vibration</li> </ul>	<ul style="list-style-type: none"> <li>Engine compartment component grounding.</li> <li>Engine mounts.</li> <li>Exhaust.</li> <li>Drive belt and pulleys.</li> </ul>	<ul style="list-style-type: none"> <li>GO to Pinpoint Test C.</li> </ul>
<ul style="list-style-type: none"> <li>Engine Accessory Vibration</li> </ul>	<ul style="list-style-type: none"> <li>Drive belt and pulleys.</li> <li>Mounting hardware.</li> <li>Accessories.</li> </ul>	<ul style="list-style-type: none"> <li>REFER to Section 303-05.</li> </ul>
<ul style="list-style-type: none"> <li>Driveshaft Vibration</li> </ul>	<ul style="list-style-type: none"> <li>Driveshaft — runout indexing (axle/transmission), pinion flange, U-joints and balance.</li> </ul>	<ul style="list-style-type: none"> <li>REFER to driveline vibration in Section 205-00.</li> </ul>
<ul style="list-style-type: none"> <li>Tire/Wheel Runout</li> </ul>	<ul style="list-style-type: none"> <li>Imbalanced tires.</li> <li>Damaged tire/wheel.</li> </ul>	<ul style="list-style-type: none"> <li>GO to Pinpoint Test A.</li> </ul>
<ul style="list-style-type: none"> <li>Brakes — Vibration/Shudder</li> </ul>	<ul style="list-style-type: none"> <li>Brake pads.</li> <li>Brake discs and hubs.</li> <li>Brake calipers.</li> </ul>	<ul style="list-style-type: none"> <li>REFER to Section 206-00.</li> </ul>
<ul style="list-style-type: none"> <li>Axle Noise</li> </ul>	<ul style="list-style-type: none"> <li>Improper axle lubricant level.</li> <li>Axle housing damage.</li> <li>Axle shaft/splines/bearings.</li> <li>Differential gears/bearings.</li> <li>Broken ring gear bolts.</li> <li>Broken gear teeth.</li> <li>Incorrect clearance between axle gears (ring and pinion).</li> <li>Pinion gear/bearings.</li> </ul>	<ul style="list-style-type: none"> <li>REFER to Section 205-02A, Section 205-02B, Section 205-02C or Section 205-03.</li> </ul>
<ul style="list-style-type: none"> <li>Noise or Vibration — 4WD Vehicles</li> </ul>	<ul style="list-style-type: none"> <li>Tires/wheels.</li> <li>Wheel bearings.</li> <li>Driveshafts/U-joints/CV joints/front axle companion shaft runout.</li> <li>Engine/transmission mounts.</li> <li>Transfer case.</li> <li>Engine.</li> <li>Transmission.</li> </ul>	<ul style="list-style-type: none"> <li>REFER to Section 204-04.</li> <li>REFER to Section 204-01B.</li> <li>REFER to Section 205-00.</li> <li>GO to Pinpoint Test C.</li> <li>REFER to Section 308-07A or Section 308-07B.</li> <li>REFER to Section 303-00.</li> <li>REFER to Section 307-01A or Section 307-01B for automatic transmissions or Section 308-00 for manual transmissions.</li> </ul>



**BUY IT NOW!**

**Click Here To Order**



**DIAGNOSIS AND TESTING (Continued)****Noise, Vibration and Harshness (Continued)**

Condition	Possible Source	Action
<ul style="list-style-type: none"> <li>Driveshaft Joint Noise and Vibration</li> </ul>	<ul style="list-style-type: none"> <li>Worn U-joints/CV joints.</li> <li>Center bearing support driveshaft.</li> <li>Worn slip yoke.</li> <li>Worn/damaged driveshaft.</li> </ul>	<ul style="list-style-type: none"> <li>REFER to Section 205-00.</li> </ul>
<ul style="list-style-type: none"> <li>Non-Axle Noise</li> </ul>	<ul style="list-style-type: none"> <li>Grille whistle.</li> <li>Trim moulding.</li> <li>Aftermarket add-ons (running boards, grounding body-to-frame, antennas, visors, bug deflectors, etc.).</li> <li>Drive belt squeal or chirp.</li> <li>Tires.</li> <li>Exhaust.</li> <li>Transmission.</li> <li>Speed control system.</li> <li>Power steering system.</li> <li>Auxiliary transmission fluid cooler.</li> </ul>	<ul style="list-style-type: none"> <li>GO to Pinpoint Test E.</li> <li>REFER to Section 303-05.</li> <li>REFER to Section 204-04.</li> <li>REFER to Section 309-00.</li> <li>REFER to Section 307-01A or Section 307-01B for automatic transmissions or Section 308-00 for manual transmissions.</li> <li>REFER to Section 310-03.</li> <li>REFER to Section 211-00.</li> <li>REFER to Section 307-02.</li> </ul>
<ul style="list-style-type: none"> <li>Wheel End Vibration</li> </ul>	<ul style="list-style-type: none"> <li>Tires/wheels.</li> <li>Wheel bearing.</li> <li>Brake drum/brake disc imbalance.</li> <li>Engine or transmission mounts.</li> </ul>	<ul style="list-style-type: none"> <li>GO to Pinpoint Test D.</li> </ul>
<ul style="list-style-type: none"> <li>Engine Run-Up Vibration</li> </ul>	<ul style="list-style-type: none"> <li>Engine, Transmission, Exhaust.</li> <li>Engine.</li> <li>Transmission.</li> <li>Exhaust.</li> </ul>	<ul style="list-style-type: none"> <li>PERFORM the NERU and DERU tests; refer to Road Test in this section.</li> <li>REFER to Section 303-00.</li> <li>REFER to Section 307-01A or Section 307-01B for automatic transmissions or Section 308-00 for manual transmissions.</li> <li>REFER to Section 309-00.</li> </ul>
<ul style="list-style-type: none"> <li>Noise and Vibration While Turning; Clicking, Popping or Grinding</li> </ul>	<ul style="list-style-type: none"> <li>Inadequate or contaminated lube in the CV joint.</li> <li>A component contacting the halfshaft assembly.</li> <li>Wheel bearings.</li> <li>Brake components.</li> <li>Suspension components.</li> <li>Steering components.</li> </ul>	<ul style="list-style-type: none"> <li>REFER to Section 205-04.</li> <li>INSPECT and CORRECT as necessary.</li> <li>REFER to Section 204-01B (4x4) or Section 206-03 (4x2).</li> <li>REFER to Section 206-00.</li> <li>REFER to Section 204-00.</li> <li>REFER to Section 211-00.</li> </ul>



**BUY IT NOW!**

**Click Here To Order**



**DIAGNOSIS AND TESTING (Continued)****Noise, Vibration and Harshness (Continued)**

Condition	Possible Source	Action
<ul style="list-style-type: none"> <li>Shudder, Vibration During Acceleration</li> </ul>	<ul style="list-style-type: none"> <li>Excessively high CV joint operating angles caused by improper ride height.</li> <li>CV joint.</li> <li>Axle assembly mispositioned.</li> <li>Front suspension components.</li> <li>Driveline angles out of specification.</li> <li>Binding, damaged or galled splines on the slip-yoke.</li> <li>U-joints binding or seized.</li> </ul>	<ul style="list-style-type: none"> <li>REFER to Section 204-00.</li> <li>REFER to Section 205-04.</li> <li>CHECK the axle mounts for damage and wear. REPAIR as necessary.</li> <li>CHECK for worn suspension bushings and damaged components. REPAIR as necessary.</li> <li>CHECK the driveline angles; REFER to Section 205-00. CORRECT as necessary.</li> <li>CHECK the transmission for proper lubricant. CLEAN and LAP the splines. LUBRICATE the splines with Premium Long-Life Grease XG-1-C or equivalent meeting Ford specification ESA-M1C75-B. REFER to Section 205-01.</li> </ul>
<ul style="list-style-type: none"> <li>CV Joint Pullout or Pull-Apart</li> </ul>	<ul style="list-style-type: none"> <li>Retaining clip missing or improperly seated.</li> <li>Frame/body damage.</li> <li>Front suspension components.</li> </ul>	<ul style="list-style-type: none"> <li>REFER to Section 205-04.</li> <li>INSPECT and REPAIR as necessary.</li> <li>REFER to Section 204-00.</li> </ul>
<ul style="list-style-type: none"> <li>Whistle</li> </ul>	<ul style="list-style-type: none"> <li>Body system.</li> </ul>	<ul style="list-style-type: none"> <li>REFER to Section 501-00.</li> </ul>
<ul style="list-style-type: none"> <li>Wind Noise or Rattle</li> </ul>	<ul style="list-style-type: none"> <li>Body system.</li> <li>Exterior trim/ornamentation.</li> <li>Interior trim/ornamentation.</li> <li>Instrument panel.</li> <li>Door.</li> </ul>	<ul style="list-style-type: none"> <li>REFER to the appropriate section in Group 5.</li> </ul>

**Pinpoint Tests**

These pinpoint tests are designed to take the technician through a step-by-step diagnosis procedure to determine the cause of a condition. It may not always be necessary to follow a chart to its conclusion. Perform only the steps necessary to correct the condition. Then check the operation of the system to make sure the condition has been corrected. It is sometimes necessary to remove various vehicle components to gain access to the component to be tested. Refer to the applicable section for removal and installation of components. After verifying that the condition has been corrected, make sure all components removed have been installed.



**DIAGNOSIS AND TESTING (Continued)**

**PINPOINT TEST A: HIGH-SPEED SHAKE**

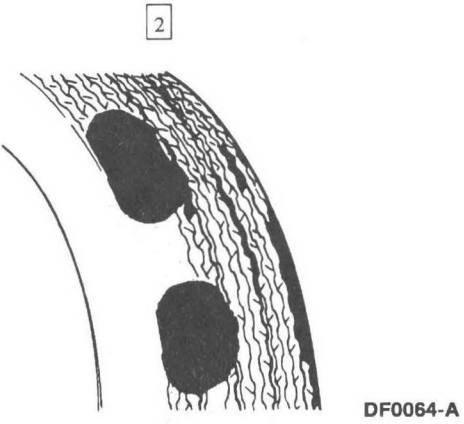
TEST CONDITIONS	TEST DETAILS/RESULTS/ACTIONS
<b>A1 ROAD TEST FOR SHAKE/VIBRATION</b>	
	<ol style="list-style-type: none"> <li>1 Accelerate the vehicle to the speed at which the shake/vibration occurred.</li> <li>2 Record the critical vehicle speed and engine rpm.</li> <li>3 Place the transmission in neutral and allow the engine to return to idle.                             <ul style="list-style-type: none"> <li>• Does the shake/vibration disappear during the neutral coast?                                     <ul style="list-style-type: none"> <li>→ <b>Yes</b> PERFORM the neutral engine run-up (NERU) test and the drive engine run-up (DERU) test; REFER to Road Test in this section.</li> <li>→ <b>No</b> GO to A2.</li> </ul> </li> </ul> </li> </ol>
<b>A2 INSPECT THE TIRES AND THE WHEELS</b>	
<p><b>⚠ WARNING:</b> The electrical power to the air suspension system must be shut off prior to hoisting, jacking or towing an air suspension vehicle. This can be accomplished by turning off the air suspension switch. Failure to do so can result in unexpected inflation or deflation of the air springs, which can result in shifting of the vehicle during these operations.</p>	
	<ol style="list-style-type: none"> <li>1 Raise and support the vehicle; refer to Section 100-02.</li> <li>2 Inspect the tires and the wheels for extreme wear and damage. Inspect the tires for cupping and flat spots.                             <ul style="list-style-type: none"> <li>• Is the condition of the tires and the wheels OK?                                     <ul style="list-style-type: none"> <li>→ <b>Yes</b> GO to A3.</li> <li>→ <b>No</b> CHECK the suspension components for misalignment, abnormal wear and damage; REFER to Section 204-00. CORRECT the suspension concerns and REPLACE the worn/damaged tires and wheels. PERFORM a road test.</li> </ul> </li> </ul> </li> </ol>

(Continued)

**100% SATISFACTION GUARANTEED**

**BUY IT NOW!**

**Click Here To Order**



**DIAGNOSIS AND TESTING (Continued)**

**PINPOINT TEST A: HIGH-SPEED SHAKE (Continued)**

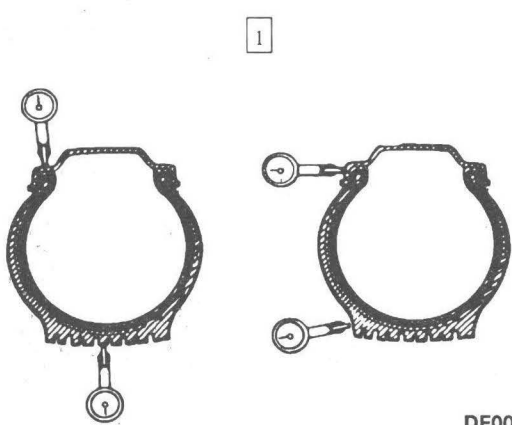
TEST CONDITIONS	TEST DETAILS/RESULTS/ACTIONS
<p><b>A3 CHECK THE WHEEL BEARINGS</b></p>	<p>1 Spin the tires by hand to check for wheel bearing roughness. Check wheel bearing end play.</p> <ul style="list-style-type: none"> <li>• Are the wheel bearings OK?</li> </ul> <p>→ <b>Yes</b> GO to A4.</p> <p>→ <b>No</b> REPLACE the wheel bearings as required; REFER to Section 204-01B (4x4) or Section 206-03 (4x2). PERFORM a road test.</p>
<p><b>A4 CHECK THE TIRE AND WHEEL BALANCE</b></p>	<p>1 Check the tire and wheel balance.</p> <ul style="list-style-type: none"> <li>• Are the tires and wheels balanced?</li> </ul> <p>→ <b>Yes</b> GO to A5.</p> <p>→ <b>No</b> BALANCE the tires and wheels; REFER to Section 204-04. PERFORM a road test.</p>
<p><b>A5 MEASURE RUNOUTS</b></p> <div style="text-align: center;"> <p>1</p>  <p>DF0065-A</p> </div>	<p>1 For each wheel position measure, locate and mark:</p> <ul style="list-style-type: none"> <li>— high point of tire and wheel assembly total radial runout.</li> <li>— high point of wheel radial runout.</li> <li>— high point of wheel lateral runout.</li> </ul>

(Continued)

100% SATISFACTION GUARANTEED

BUY IT NOW!

Click Here To Order







**DIAGNOSIS AND TESTING (Continued)**

**PINPOINT TEST A: HIGH-SPEED SHAKE (Continued)**

TEST CONDITIONS	TEST DETAILS/RESULTS/ACTIONS																								
<p><b>A5 MEASURE RUNOUTS (Continued)</b></p>	<p>2 Record all measurements in the chart.</p> <table border="1" data-bbox="837 393 1412 808"> <thead> <tr> <th>Assembly Position</th> <th>Tire/Wheel Assembly Total Radial Runout</th> <th>Wheel Radial Runout</th> <th>Wheel Lateral Runout</th> </tr> </thead> <tbody> <tr> <td>Left Front</td> <td></td> <td></td> <td></td> </tr> <tr> <td>Right Front</td> <td></td> <td></td> <td></td> </tr> <tr> <td>Left Rear</td> <td></td> <td></td> <td></td> </tr> <tr> <td>Right Rear</td> <td></td> <td></td> <td></td> </tr> <tr> <td>Example</td> <td>1.52 mm (0.060 Inch)</td> <td>0.50 mm (0.020 Inch)</td> <td>0.63 mm (0.025 Inch)</td> </tr> </tbody> </table> <ul style="list-style-type: none"> <li>• Have all the tire and wheel assemblies been measured?</li> </ul> <p>→ <b>Yes</b> GO to <b>A6</b>.</p> <p>→ <b>No</b> COMPLETE Step <b>A5</b>.</p>	Assembly Position	Tire/Wheel Assembly Total Radial Runout	Wheel Radial Runout	Wheel Lateral Runout	Left Front				Right Front				Left Rear				Right Rear				Example	1.52 mm (0.060 Inch)	0.50 mm (0.020 Inch)	0.63 mm (0.025 Inch)
Assembly Position	Tire/Wheel Assembly Total Radial Runout	Wheel Radial Runout	Wheel Lateral Runout																						
Left Front																									
Right Front																									
Left Rear																									
Right Rear																									
Example	1.52 mm (0.060 Inch)	0.50 mm (0.020 Inch)	0.63 mm (0.025 Inch)																						

(Continued)

**100% SATISFACTION GUARANTEED**

**BUY IT NOW!**

**Click Here To Order**

PayPal American Express Discover MasterCard VISA

**DIAGNOSIS AND TESTING (Continued)**

**PINPOINT TEST A: HIGH-SPEED SHAKE (Continued)**

TEST CONDITIONS	TEST DETAILS/RESULTS/ACTIONS																				
<p><b>A6 ANALYZE THE RUNOUT MEASUREMENTS</b></p>	<p><b>1</b> Measurements obtained in Step A5 must fall within the specifications listed in Condition 1 in the following chart.</p> <table border="1" data-bbox="869 457 1428 1212"> <thead> <tr> <th>Condition</th> <th>Assembly Total Radial Runout</th> <th>Wheel Radial Runout</th> <th>Wheel Lateral Runout</th> </tr> </thead> <tbody> <tr> <td>1</td> <td>Less Than 1.02 mm (0.04 Inch)</td> <td>Less Than 1.14 mm (0.045 Inch)</td> <td>Less Than 1.14 mm (0.045 Inch)</td> </tr> <tr> <td>2</td> <td>Less Than 1.02 mm (0.04 Inch)</td> <td>More Than 1.14 mm (0.045 Inch)</td> <td>Less Than 1.14 mm (0.045 Inch)</td> </tr> <tr> <td>3</td> <td>Less Than 1.02 mm (0.04 Inch)</td> <td>Less Than 1.14 mm (0.045 Inch)</td> <td>More Than 1.14 mm (0.045 Inch)</td> </tr> <tr> <td>4</td> <td>More Than 1.02 mm (0.04 Inch)</td> <td>Less Than 1.14 mm (0.045 Inch)</td> <td>Less Than 1.14 mm (0.045 Inch)</td> </tr> </tbody> </table> <ul style="list-style-type: none"> <li>• Do the measurements obtained in A5 fall within the specifications listed in Condition 1 in the chart?</li> </ul> <p>→ <b>Yes</b> Condition 1: Good assembly. GO to <b>A12</b>.</p> <p>→ <b>No</b> If condition 2, 3 or 4, for a tire and wheel on the rear axle/4x4 front axle, GO to <b>A7</b>. If condition 2 or 3, for a front tire and wheel on a 4x2 vehicle, GO to <b>A8</b>. If condition 4, GO to <b>A9</b>.</p>	Condition	Assembly Total Radial Runout	Wheel Radial Runout	Wheel Lateral Runout	1	Less Than 1.02 mm (0.04 Inch)	Less Than 1.14 mm (0.045 Inch)	Less Than 1.14 mm (0.045 Inch)	2	Less Than 1.02 mm (0.04 Inch)	More Than 1.14 mm (0.045 Inch)	Less Than 1.14 mm (0.045 Inch)	3	Less Than 1.02 mm (0.04 Inch)	Less Than 1.14 mm (0.045 Inch)	More Than 1.14 mm (0.045 Inch)	4	More Than 1.02 mm (0.04 Inch)	Less Than 1.14 mm (0.045 Inch)	Less Than 1.14 mm (0.045 Inch)
Condition	Assembly Total Radial Runout	Wheel Radial Runout	Wheel Lateral Runout																		
1	Less Than 1.02 mm (0.04 Inch)	Less Than 1.14 mm (0.045 Inch)	Less Than 1.14 mm (0.045 Inch)																		
2	Less Than 1.02 mm (0.04 Inch)	More Than 1.14 mm (0.045 Inch)	Less Than 1.14 mm (0.045 Inch)																		
3	Less Than 1.02 mm (0.04 Inch)	Less Than 1.14 mm (0.045 Inch)	More Than 1.14 mm (0.045 Inch)																		
4	More Than 1.02 mm (0.04 Inch)	Less Than 1.14 mm (0.045 Inch)	Less Than 1.14 mm (0.045 Inch)																		

(Continued)



**BUY IT NOW!**

**Click Here To Order**



**DIAGNOSIS AND TESTING (Continued)****PINPOINT TEST A: HIGH-SPEED SHAKE (Continued)**

TEST CONDITIONS	TEST DETAILS/RESULTS/ACTIONS
<b>A7</b> MEASURE THE AXLE FLANGE/WHEEL HUB BOLT, PILOT AND FACE RUNOUT	<p>1 Measure the axle flange/wheel hub bolt, pilot and face runout; refer to Section 205-00.</p> <ul style="list-style-type: none"> <li>• Is runout within specification?</li> </ul> <p>→ <b>Yes</b> If condition 2 or 3 from A6, GO to <b>A8</b>. If condition 4, GO to <b>A9</b>.</p> <p>→ <b>No</b> REPLACE as necessary. CHECK the runout as in A5. If condition 2 or 3 from A6 persists, GO to <b>A8</b>. If condition 1, GO to <b>A12</b>. If condition 4, GO to <b>A9</b>.</p>
<b>A8</b> REPLACE THE WHEEL	<p>1 Measure the runout on the new tire and wheel assembly.</p> <ul style="list-style-type: none"> <li>• Is the assembly within specification from A6?</li> </ul> <p>→ <b>Yes</b> GO to <b>A11</b>.</p> <p>→ <b>No</b> If condition 2 or 3, REPLACE the wheel and RECHECK. If condition 4, GO to <b>A9</b>.</p>
<b>A9</b> INDEX THE TIRE AND WHEEL ASSEMBLY	<p>1 Align the high point of total assembly radial runout 180 degrees away from the high point of the wheel radial runout.</p> <p>2 Measure the total assembly radial runout.</p> <ul style="list-style-type: none"> <li>• Is the total radial runout less than 1.02 mm (0.04 inch)?</li> </ul> <p>→ <b>Yes</b> GO to <b>A11</b>.</p> <p>→ <b>No</b> GO to <b>A10</b>.</p>

(Continued)



**BUY IT NOW!**

**Click Here To Order** 







**DIAGNOSIS AND TESTING (Continued)****PINPOINT TEST A: HIGH-SPEED SHAKE (Continued)**

TEST CONDITIONS	TEST DETAILS/RESULTS/ACTIONS
<b>A10</b> REPLACE THE TIRE	<p>1 Measure the total assembly radial runout on the new tire assembly.</p> <ul style="list-style-type: none"> <li>• Is the total radial runout less than 1.02 mm (0.04 inch)?</li> </ul> <p>→ <b>Yes</b> GO to <b>A11</b>.</p> <p>→ <b>No</b> INDEX the tire and wheel assembly as in A9. If the new assembly is now within specification GO to <b>A11</b>. If the new assembly is still not within specification, GO to <b>A12</b>.</p>
<b>A11</b> ROAD TEST	<p>1 Balance the new tire and wheel assembly.</p> <p>2 After all assemblies have been checked and corrected, road test the vehicle.</p> <ul style="list-style-type: none"> <li>• Is the vehicle operating correctly?</li> </ul> <p>→ <b>Yes</b> Vehicle is OK.</p> <p>→ <b>No</b> GO to <b>A12</b>.</p>
<b>A12</b> SUBSTITUTE WHEELS AND TIRES	<p>1 Substitute a known good set of wheels and tires.</p> <p>2 Road test the vehicle.</p> <p>3 If the vehicle exhibits a shake or vibration, note the vehicle speed and engine rpm at which it occurs.</p> <ul style="list-style-type: none"> <li>• Is the vibration present?</li> </ul> <p>→ <b>Yes</b> REFER to driveline vibration in Section 205-00.</p> <p>→ <b>No</b> INSTALL the original tire and wheel assemblies one by one, road testing at each step until the damaged tire(s) is identified. REPLACE tire(s) as necessary and RETEST.</p>





**BUY IT NOW!**

Click Here To Order



**DIAGNOSIS AND TESTING (Continued)****PINPOINT TEST B: TIP-IN MOAN**

TEST CONDITIONS	TEST DETAILS/RESULTS/ACTIONS
<b>B1 CHECK THE ENGINE AIR CLEANER INSTALLATION</b>	
	<p>1 Refer to Section 303-12 for proper installation of the engine air cleaner.</p> <ul style="list-style-type: none"> <li>• Is the engine air cleaner properly installed?</li> </ul> <p>→ <b>Yes</b> GO to <b>B2</b>.</p> <p>→ <b>No</b> CORRECT the condition and PERFORM a road test. If the moan persists, GO to <b>B2</b>.</p>
<b>B2 INSPECT THE ENGINE AND THE TRANSMISSION MOUNTS</b>	
	<p>1 Inspect and replace the engine and the transmission mounts as necessary. Refer to Section 303-01A for 4.2L engines, Section 303-01B for 4.6L and 5.4L engines, Section 307-01A or Section 307-01B for automatic transmissions or Section 308-03 for manual transmissions.</p> <p>2 Neutralize the mounts; refer to Powertrain/Drivetrain Mount Neutralizing in this section.</p> <p>3 Perform a road test.</p> <ul style="list-style-type: none"> <li>• Is moan eliminated?</li> </ul> <p>→ <b>Yes</b> The vehicle is OK.</p> <p>→ <b>No</b> GO to <b>B3</b>.</p>
<b>B3 INSPECT THE EXHAUST SYSTEM</b>	
<p> <b>WARNING:</b> Exhaust gases contain carbon monoxide, which is harmful to health and potentially lethal. Exhaust system leaks must be repaired immediately. Never operate the engine in an enclosed area.</p> <p> <b>WARNING:</b> Exhaust system components are hot.</p>	
	<p>1 Inspect and replace the exhaust components as necessary; refer to Section 309-00.</p> <p>2 Neutralize the exhaust system; refer to Exhaust System Neutralizing in this section.</p>

(Continued)



**BUY IT NOW!**

**Click Here To Order** 





**DIAGNOSIS AND TESTING (Continued)**

**PINPOINT TEST B: TIP-IN MOAN (Continued)**

TEST CONDITIONS	TEST DETAILS/RESULTS/ACTIONS
<b>B3</b> INSPECT THE EXHAUST SYSTEM (Continued)	
	<p><b>3</b> Perform a road test.</p> <ul style="list-style-type: none"> <li>• Is the moan eliminated?</li> </ul> <p>→ <b>Yes</b> The vehicle is OK.</p> <p>→ <b>No</b> REFER to Section 303-05 for diagnosis and testing of the accessory drive system.</p>

**PINPOINT TEST C: IDLE BOOM/SHAKE/VIBRATION**

TEST CONDITIONS	TEST DETAILS/RESULTS/ACTIONS
<b>C1</b> CHECK FOR ENGINE COMPARTMENT COMPONENT GROUNDING	
	<p><b>1</b> Check the engine compartment for any component that is grounding between the engine and the body or chassis.</p> <ul style="list-style-type: none"> <li>• Are all components OK?</li> </ul> <p>→ <b>Yes</b> GO to <b>C2</b>.</p> <p>→ <b>No</b> CORRECT the condition and PERFORM a road test. If the boom/shake/vibration is still present, GO to <b>C2</b>.</p>
<b>C2</b> INSPECT THE ENGINE AND THE TRANSMISSION MOUNTS	
	<p><b>1</b> Inspect and replace the engine and the transmission mounts as necessary. Refer to Section 303-01A for 4.2L engines, Section 303-01B for 4.6L and 5.4L engines, Section 307-01A or Section 307-01B for automatic transmissions or Section 308-03 for manual transmissions.</p> <p><b>2</b> Neutralize the mounts; refer to Powertrain/Drivetrain Mount Neutralizing in this section.</p> <p><b>3</b> Perform a road test.</p> <ul style="list-style-type: none"> <li>• Is the condition corrected?</li> </ul> <p>→ <b>Yes</b> The vehicle is OK.</p> <p>→ <b>No</b> GO to <b>C3</b>.</p>

(Continued)

**100% SATISFACTION GUARANTEED**



**BUY IT NOW!**

**Click Here To Order**



PayPal American Express Discover MasterCard VISA

**DIAGNOSIS AND TESTING (Continued)**

**PINPOINT TEST C: IDLE BOOM/SHAKE/VIBRATION (Continued)**

TEST CONDITIONS	TEST DETAILS/RESULTS/ACTIONS
<p><b>C3 INSPECT THE EXHAUST SYSTEM</b></p>	
<p> <b>WARNING:</b> Exhaust gases contain carbon monoxide, which is harmful to health and potentially lethal. Exhaust system leaks must be repaired immediately. Never operate the engine in an enclosed area.</p> <p> <b>WARNING:</b> Exhaust system components are hot.</p> <p><b>NOTE:</b> Discard this step if it has already been performed in Step B3. GO to Section 303-05 for diagnosis and testing of the accessory drive system.</p>	
	<p><b>1</b> Inspect and replace the exhaust components as necessary; refer to Section 309-00.</p> <p><b>2</b> Neutralize the exhaust system; refer to Exhaust System Neutralizing in this section.</p> <p><b>3</b> Perform a road test.</p> <ul style="list-style-type: none"> <li>• Is the condition corrected?</li> </ul> <p>→ <b>Yes</b> The vehicle is OK.</p> <p>→ <b>No</b> REFER to Section 303-05 for diagnosis and testing of the accessory drive system.</p>

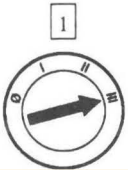
**PINPOINT TEST D: WHEEL END VIBRATION ANALYSIS**

TEST CONDITIONS	TEST DETAILS/RESULTS/ACTIONS
<p><b>D1 ROAD TEST FOR VIBRATION/SHUDDER</b></p>	
	<p><b>1</b> Determine if the vibration/shudder is induced when making a light stop by applying the service brakes.</p> <ul style="list-style-type: none"> <li>• Is the vibration/shudder present?</li> </ul> <p>→ <b>Yes</b> INSPECT the brake system; REFER to Section 206-00.</p> <p>→ <b>No</b> GO to <b>D2</b>.</p>
<p><b>D2 PERFORM A NEUTRAL COAST TEST</b></p>	
<p><b>1</b></p>  <p><b>2</b></p> 	<p><b>2</b> Accelerate to the maximum legal speed.</p>

(Continued)

**100% SATISFACTION GUARANTEED**

**BUY IT NOW!**

**Click Here To Order**



**DIAGNOSIS AND TESTING (Continued)**

**PINPOINT TEST D: WHEEL END VIBRATION ANALYSIS (Continued)**

TEST CONDITIONS	TEST DETAILS/RESULTS/ACTIONS
<b>D2 PERFORM A NEUTRAL COAST TEST (Continued)</b>	
<div style="text-align: center;"> <div style="border: 1px solid black; width: 40px; height: 20px; margin: 0 auto; display: flex; justify-content: space-around; align-items: center;"> <span>3</span> </div> <div style="margin: 5px 0;">↓</div> <div style="border: 1px solid black; width: 100px; height: 20px; margin: 0 auto; display: flex; justify-content: space-around; align-items: center;"> <span>P</span> <span>R</span> <span>N</span> <span>D</span> <span>2</span> <span>1</span> </div> <div style="margin: 5px 0;">↑</div> </div>	<div style="border: 1px solid black; padding: 5px;"> <div style="display: flex; align-items: flex-start;"> <div style="border: 1px solid black; width: 20px; height: 20px; display: flex; align-items: center; justify-content: center; margin-right: 5px;">3</div> <div> <p>Allow the engine to return to idle. If the vibration exists with the transmission in NEUTRAL, the source is probably in the wheels, the tires, or the driveline.</p> <ul style="list-style-type: none"> <li>• Does the vibration disappear during the neutral coast test?</li> </ul> <p>→ <b>Yes</b> PERFORM the neutral engine run-up (NERU) and the drive engine run-up (DERU) tests; REFER to Road Test in this section.</p> <p>→ <b>No</b> REFER to Section 204-04 for diagnosis and testing of the wheels and tires.</p> </div> </div> </div>

**PINPOINT TEST E: NON-AXLE NOISE**

TEST CONDITIONS	TEST DETAILS/RESULTS/ACTIONS
<b>E1 INSPECT THE VEHICLE TRIM</b>	
	<div style="border: 1px solid black; padding: 5px;"> <div style="display: flex; align-items: flex-start;"> <div style="border: 1px solid black; width: 20px; height: 20px; display: flex; align-items: center; justify-content: center; margin-right: 5px;">1</div> <div> <p>Inspect the grille and trim mouldings to see if they are the source of the noise; refer to Section 501-08.</p> <ul style="list-style-type: none"> <li>• Are the vehicle trim components causing the noise?</li> </ul> <p>→ <b>Yes</b> REPLACE or REPAIR as necessary; REFER to Section 501-08.</p> <p>→ <b>No</b> GO to E2.</p> </div> </div> </div>
<b>E2 CHECK FOR NON-FACTORY ACCESSORIES</b>	
	<div style="border: 1px solid black; padding: 5px;"> <div style="display: flex; align-items: flex-start;"> <div style="border: 1px solid black; width: 20px; height: 20px; display: flex; align-items: center; justify-content: center; margin-right: 5px;">1</div> <div> <p>Check for non-factory accessories as the source of the noise. Example: running boards grounding the body to the frame, antennas, visors, bug deflectors, etc.</p> <ul style="list-style-type: none"> <li>• Are any accessories the cause of the noise?</li> </ul> <p>→ <b>Yes</b> ADJUST, REPAIR, or REPLACE the accessories/fasteners as required.</p> <p>→ <b>No</b> GO to E3.</p> </div> </div> </div>

(Continued)

SATISFACTION  
100%  
GUARANTEED

BUY IT NOW!

Click Here To Order

**DIAGNOSIS AND TESTING (Continued)****PINPOINT TEST E: NON-AXLE NOISE (Continued)**

TEST CONDITIONS	TEST DETAILS/RESULTS/ACTIONS
E3 CHECK FOR ENGINE/TRANSMISSION NOISE	
	<p>1 Perform the Road Test in this section.</p> <ul style="list-style-type: none"> <li>• Is the noise engine speed related?</li> </ul> <p>→ <b>Yes</b> REFER to Section 303-00 for general engine, Section 307-01A or Section 307-01B for automatic transmissions or Section 308-00 for manual transmissions.</p> <p>→ <b>No</b> GO to the Symptom Chart.</p>

**GENERAL PROCEDURES****Powertrain/Drivetrain Mount Neutralizing**

 **WARNING:** Exhaust gases contain carbon monoxide, which is harmful to health and potentially lethal. Exhaust system leaks must be repaired immediately. Never operate the engine in an enclosed area.

 **WARNING:** Exhaust system components are hot.

**NOTE:** Neutralize the exhaust system to relieve strain on mounts which may be sufficiently bound up to transmit vibration as if grounded.

1.  **WARNING:** The electrical power to the air suspension system must be shut off prior to hoisting, jacking or towing an air suspension vehicle. This can be accomplished by turning off the air suspension switch. Failure to do so can result in unexpected inflation or deflation of the air springs, which can result in shifting of the vehicle during these operations.

 **CAUTION:** Make sure the system is warmed up to normal operating temperature, as thermal expansion can be the cause of a strain problem.

Raise and support the vehicle; for additional information, refer to Section 100-02.



**BUY IT NOW!**  
Click Here To Order 



**GENERAL PROCEDURES (Continued)**

2. Loosen all hanger attachments and reposition the hangers until they hang free and straight.
3. Loosen all flange joints.
4. Tighten all the hanger clamps and flanges (tighten the manifold flange joint last); for additional information, refer to Section 309-00.
  - Verify adequate clearance to prevent grounding at any point in the system.
  - After neutralization, the rubber in the exhaust hangers should show some flexibility when movement is applied to the exhaust system.
5. Lower the vehicle.
6. Perform a road test.

**Exhaust System Neutralizing**

 **WARNING:** Exhaust gases contain carbon monoxide, which is harmful to health and potentially lethal. Exhaust system leaks must be repaired immediately. Never operate the engine in an enclosed area.

 **WARNING:** Exhaust system components are hot.

**NOTE:** Neutralize the exhaust system to relieve strain on mounts which may be sufficiently bound up to transmit vibration as if grounded.

1.  **WARNING:** The electrical power to the air suspension system must be shut off prior to hoisting, jacking or towing an air suspension vehicle. This can be accomplished by turning off the air suspension switch. Failure to do so can result in unexpected inflation or deflation of the air springs, which can result in shifting of the vehicle during these operations.

 **CAUTION:** Make sure the system is warmed up to normal operating temperature, as thermal expansion can be the cause of a strain problem.

Raise and support the vehicle. For additional information, refer to Section 100-02.



**100% SATISFACTION GUARANTEED**

**BUY IT NOW!**

**Click Here To Order**



**GENERAL PROCEDURES (Continued)**

2. Loosen all hanger attachments and reposition the hangers until they hang free and straight.
3. Loosen all flange joints.
4. Tighten all the hanger clamps and flanges (tighten the manifold flange joint last). For additional information, refer to Section 309-00.
  - Verify adequate clearance to prevent grounding at any point in the system.
  - After neutralization, the rubber in the exhaust hangers should show some flexibility when movement is applied to the exhaust system.
5. Lower the vehicle.
6. Perform a road test.

**BUY IT NOW!****Click Here To Order** 

## GROUP

# CHASSIS 2

SECTION TITLE	PAGE
Suspension System — General Information.....	204-00-1
Front Suspension — 4x2 .....	204-01A-1
Front Suspension — 4x4 .....	204-01B-1
Rear Suspension .....	204-02-1
Wheels and Tires.....	204-04-1
Vehicle Dynamic Suspension .....	204-05-1
Driveline System — General Information .....	205-00-1
Driveshaft.....	205-01-1
Rear Drive Axle/Differential — Ford 8.8-Inch Ring Gear.....	205-02A-1
Rear Drive Axle/Differential — Ford 9.75-Inch Ring Gear.....	205-02B-1
Rear Drive Axle/Differential — Ford 10.25-Inch Ring Gear.....	205-02C-1
Front Drive Axle/Differential — Ford 8.8-Inch Ring Gear.....	205-03-1
Front Drive Halfshafts .....	205-04-1
Brake System — General Information .....	206-00-1
Drum Brake .....	206-02-1
Front Disc Brake .....	206-03-1
Rear Disc Brake .....	206-04-1
Parking Brake and Actuation .....	206-05-1
Hydraulic Brake Actuation .....	206-06-1
Power Brake Actuation.....	206-07-1
Anti-Lock Control — Rear .....	206-09A-1
Anti-Lock Control — 4-Wheel.....	206-09B-1
Steering System — General Information.....	211-00-1
Power Steering.....	211-02-1
Steering Linkage.....	211-03-1
Steering Column .....	211-04-1
Steering Column Switches.....	211-05-1

## SECTION 204-00 Suspension System — General Information

VEHICLE APPLICATION: F-150/F-250

CONTENTS	PAGE
DESCRIPTION AND OPERATION	
Wheel Alignment Angles.....	204-00-3
Camber .....	204-00-3
.....	204-00-3
.....	204-00-5
.....	204-00-5



**BUY IT NOW!**

**Click Here To Order**



<b>CONTENTS</b>	<b>PAGE</b>
Nibble.....	204-00-5
Poor Returnability/Sticky Steering.....	204-00-5
Ride Height .....	204-00-4
Shimmy.....	204-00-5
Toe.....	204-00-3
Wander .....	204-00-5
Wheel Track.....	204-00-4
 <b>DIAGNOSIS AND TESTING</b>	
Suspension System.....	204-00-6
Component Tests .....	204-00-10
Ball Joint Inspection.....	204-00-10
Shock Absorber Inspection.....	204-00-11
Wheel Bearing Inspection.....	204-00-11
Inspection and Verification .....	204-00-6
Symptom Chart.....	204-00-7
 <b>GENERAL PROCEDURES</b>	
Camber and Caster Adjustment — 4x2.....	204-00-12
Camber and Caster Adjustment — 4x4.....	204-00-13
Toe Adjustment.....	204-00-15
<b>SPECIFICATIONS</b> .....	204-00-16



## DESCRIPTION AND OPERATION

### Wheel Alignment Angles

Caster and camber are adjusted by means of adjustment slots cut into the upper control arm mounting brackets. Toe is adjusted by the use of the front wheel spindle tie rod adjusting sleeve (3310).

#### Camber

##### Negative and Positive Camber

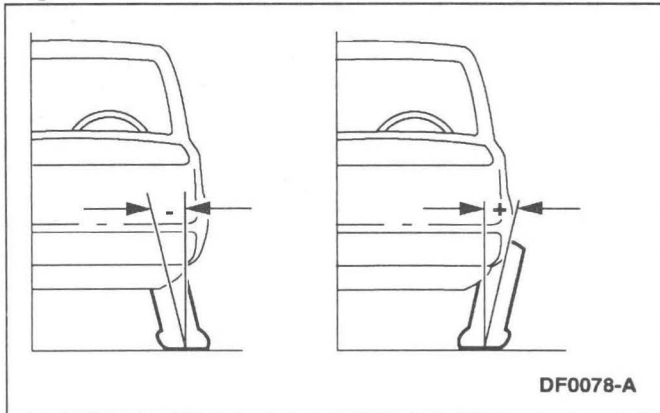

Camber is the vertical tilt of the wheel when viewed from the front. Camber can be positive or negative and has a direct effect on tire wear.

#### Caster

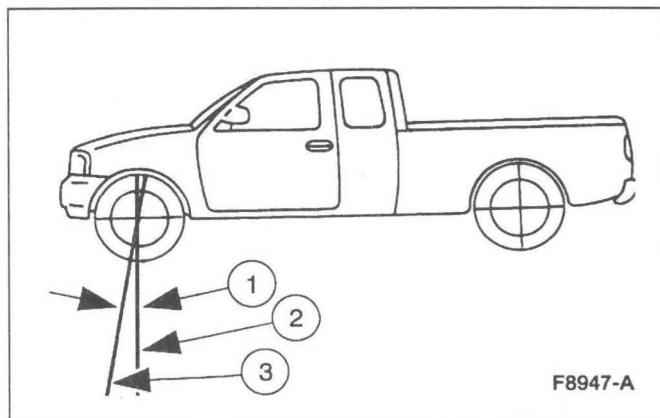

Item	Part Number	Description
1	—	Positive Caster
2	—	True Vertical
3	—	Steering Axis

Caster is the deviation from vertical of an imaginary line drawn through the ball joints when viewed from the side. The caster specifications in this section will give the vehicle the best directional stability characteristics when loaded and driven. The caster setting is not related to tire wear.

#### Toe

##### Positive Toe (Toe In)

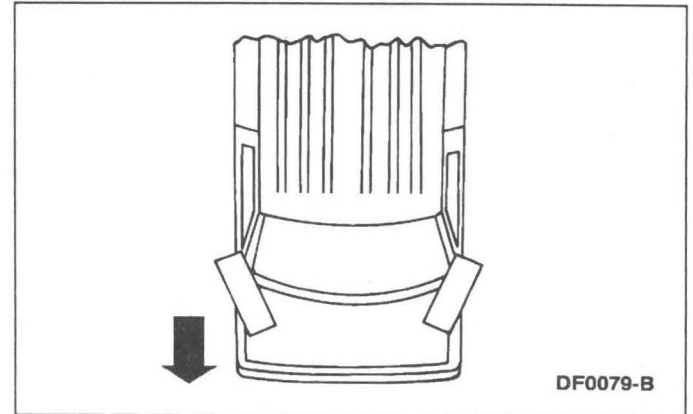

##### Negative Toe (Toe Out)

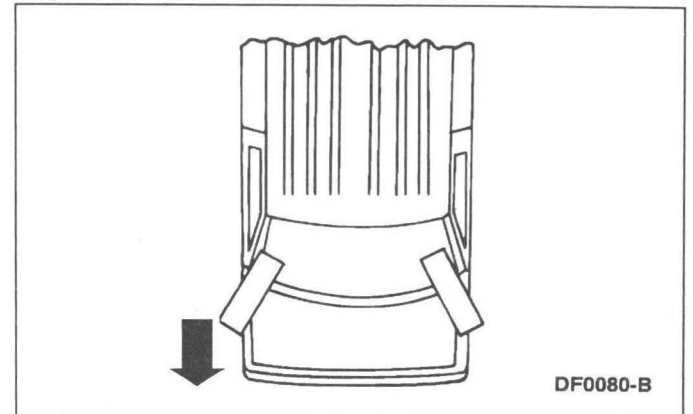

The vehicle toe setting:

- affects tire wear and directional stability.
- must be checked after adding aftermarket equipment, such as a snowplow or body.



**BUY IT NOW!**

**Click Here To Order**



**DESCRIPTION AND OPERATION (Continued)**

**Ride Height**

**Front Ride Height Measurement**

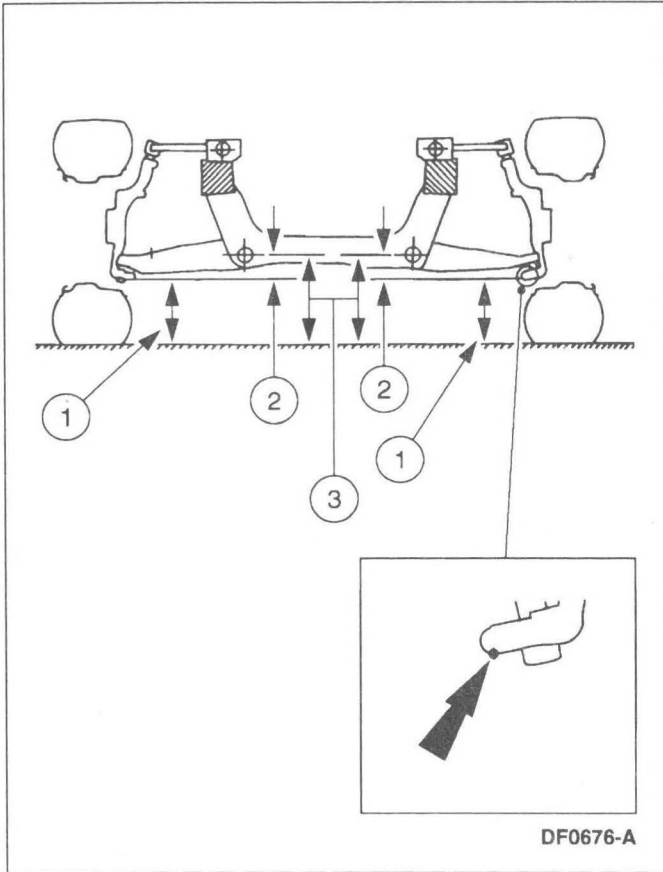

**Rear Ride Height Measurement — 4x4**

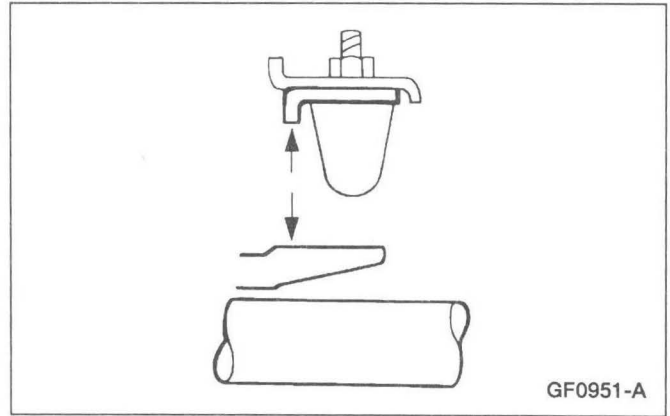

**Wheel Track**

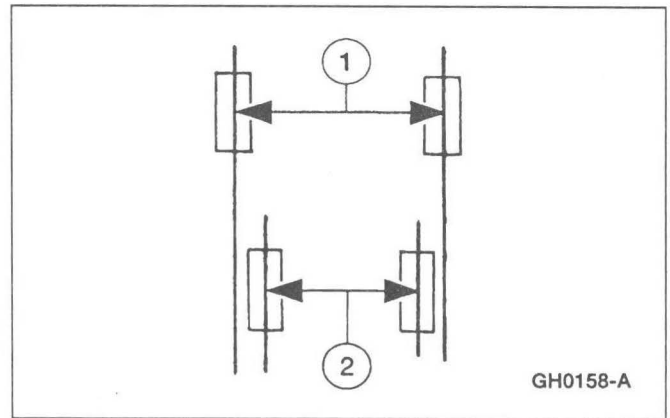

Item	Description
1	Measurement A
2	Ride Height — B-A
3	Measurement B

Item	Part Number	Description
1	—	Front Track
2	—	Rear Track

**Rear Ride Height Measurement — 4x2**

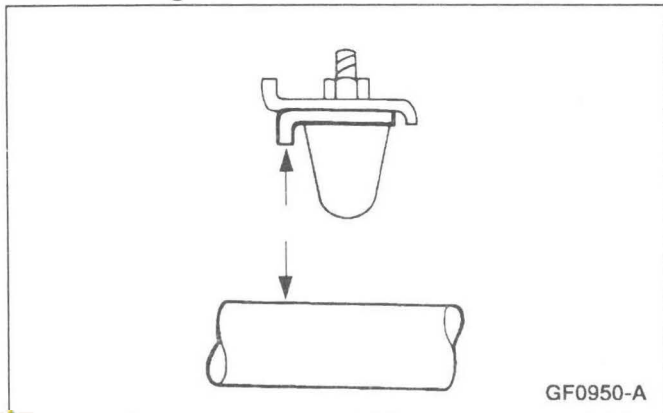

**100% SATISFACTORY GUARANTEED**

**BUY IT NOW!**

**Click Here To Order**

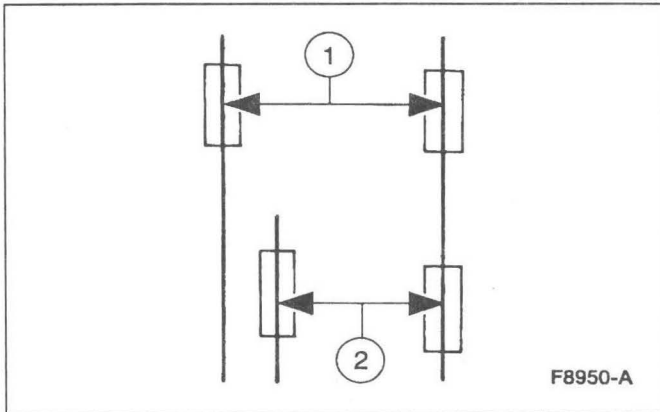
**DESCRIPTION AND OPERATION (Continued)****Dogtracking**

Item	Part Number	Description
1	—	Front Track
2	—	Rear Track Dogtracking

Dogtracking is the condition in which the rear axle is not square to the chassis. Heavily crowned roads can give the illusion of dogtracking.

**Wander**

Wander is the tendency of the vehicle to require frequent, random left and right steering wheel (3600) corrections to maintain a straight path down a level road.

**Shimmy**

Shimmy, as observed by the driver, is large, consistent, rotational oscillations of the steering wheel resulting from large, side-to-side (lateral) tire/wheel movements.

Shimmy is usually experienced near 64 km/h (40 mph), and can begin or be amplified when the tire contacts pot holes or irregularities in the road surface.

**Nibble**

Sometimes confused with shimmy, nibble is a condition resulting from tire interaction with various road surfaces and observed by the driver as small rotational oscillations of the steering wheel.

**Poor Returnability/Sticky Steering**

Poor returnability and sticky steering is used to describe the poor return of the steering wheel to center after a turn or the steering correction is completed.

**Drift/Pull**

Pull is a tugging sensation, felt by the hands on the steering wheel, that must be overcome to keep the vehicle going straight.

Drift describes what a vehicle with this condition does with hands off the steering wheel.

- A vehicle-related drift/pull, on a flat road, will cause a consistent deviation from the straight-ahead path and require constant steering input in the opposite direction to counteract the effect.
- Drift/pull may be induced by conditions external to the vehicle (i.e., wind, road camber).

**Poor Groove Feel**

Poor groove feel is characterized by little or no buildup of turning effort felt in the steering gear (3504) as the wheel is rocked slowly left and right within very small turns around center or straight-ahead (under 20 degrees of steering wheel turn). Efforts may be said to be "flat on center."

- Under 20 degrees of turn, most of the turning effort that builds up comes from the mesh of gear teeth in the steering gear. In this range, the steering wheel is not yet turned enough to feel the effort from the self-aligning forces at the road wheel or tire patch.
- In the diagnosis of a roadability problem, it is important to understand the difference between wander and poor groove feel.

**100% SATISFACTION GUARANTEED**

**BUY IT NOW!**

**Click Here To Order**

## DIAGNOSIS AND TESTING

### Suspension System

#### Inspection and Verification

1. Road test.
  - Verify the customer's concern by performing a road test on a smooth road. If any vibrations are apparent, refer to Section 100-04.
2. Inspect tires.
  - Check the tire pressure with all normal loads in the vehicle and the tires cold; refer to the vehicle certification (VC) label.
  - Verify that all tires are sized to specification; refer to Section 204-04.
  - Inspect the tires for improper wear and damage; refer to Section 204-04.
3. Inspect chassis and underbody.
  - Remove any excessive accumulation of mud, dirt or road deposits from the chassis and underbody.
4. Inspect for aftermarket equipment.
  - Check for aftermarket changes to the steering, suspension, wheel and tire components (such as competition, heavy duty, etc.) The specifications shown in this manual do not apply to vehicles equipped with aftermarket equipment.

5. If an obvious cause for an observed or reported condition is found, correct the cause (if possible) before proceeding to the next step.
6. If the fault is not visually evident, determine the symptom and proceed to the following symptom chart.

#### Visual Inspection Chart

Mechanical
<ul style="list-style-type: none"> <li>• Front wheel bearing(s)</li> <li>• Loose or damaged front or rear suspension components</li> <li>• Loose, damaged or missing suspension fastener(s)</li> <li>• Loose or damaged shackle(s)</li> <li>• Improper spring usage</li> <li>• Damaged or sagging spring(s)</li> <li>• Improper torsion bar usage</li> <li>• Damaged or sagging torsion bar(s)</li> <li>• Damaged air spring(s)</li> <li>• Damaged or leaking shock absorber(s)</li> <li>• Worn or damaged suspension bushing(s)</li> <li>• Loose, worn or damaged steering system components</li> <li>• Damaged axle components</li> </ul>

**100% SATISFACTION GUARANTEED**

**BUY IT NOW!**

**Click Here To Order**

PayPal American Express Discover MasterCard VISA

**DIAGNOSIS AND TESTING (Continued)****Symptom Chart****Symptom Chart**

<b>Condition</b>	<b>Possible Source</b>	<b>Action</b>
<ul style="list-style-type: none"> <li>• Dogtracking</li> </ul>	<ul style="list-style-type: none"> <li>• Excessive rear thrust angle.</li> <li>• Front or rear suspension components.</li> <li>• Drive axle damaged.</li> </ul>	<ul style="list-style-type: none"> <li>• ADJUST as necessary.</li> <li>• INSPECT the front and rear suspension systems. REPAIR or REPLACE as necessary. REFER to Section 204-01A (4x2), or Section 204-01B (4x4) or Section 204-02.</li> <li>• REPAIR as necessary. REFER to the appropriate section in Group 2.</li> </ul>
<ul style="list-style-type: none"> <li>• Drift/Pull</li> </ul>	<ul style="list-style-type: none"> <li>• Unequal tire pressure.</li> <li>• Excessive side-to-side difference in caster or camber.</li> <li>• Tire forces.</li> <li>• Unevenly loaded or overloaded vehicle.</li> <li>• Steering components.</li> <li>• Brake drag.</li> </ul>	<ul style="list-style-type: none"> <li>• ADJUST tire pressure.</li> <li>• ADJUST as necessary.</li> <li>• ROTATE tires front to rear.</li> <li>• NOTIFY the customer of improper vehicle loading.</li> <li>• REFER to Section 211-00.</li> <li>• REFER to Section 206-00.</li> </ul>
<ul style="list-style-type: none"> <li>• Front Bottoming or Riding Low</li> </ul>	<ul style="list-style-type: none"> <li>• Spring(s).</li> <li>• Improper spring(s).</li> <li>• Torsion bar(s).</li> <li>• Improper torsion bar(s).</li> <li>• Front suspension bumper(s).</li> </ul>	<ul style="list-style-type: none"> <li>• REPLACE any unserviceable springs. REFER to Section 204-01A (4x2).</li> <li>• REPLACE as necessary. REFER to Section 204-01A (4x2).</li> <li>• REPLACE any unserviceable torsion bar(s) as necessary. REFER to Section 204-01B (4x4).</li> <li>• REPLACE as necessary. REFER to Section 204-01B (4x4).</li> <li>• REPLACE as necessary. REFER to Section 204-01A or Section 204-01B.</li> </ul>
<ul style="list-style-type: none"> <li>• Improper Tire Wear</li> </ul>	<ul style="list-style-type: none"> <li>• Incorrect tire pressure (rapid center rib or inner and outer edge wear).</li> <li>• Excessive front or rear toe (rapid inner or outer edge wear).</li> <li>• Excessive negative or positive camber (rapid inner or outer edge wear).</li> <li>• Tires out of balance (tires cupped or dished).</li> </ul>	<ul style="list-style-type: none"> <li>• ADJUST tire pressure.</li> <li>• ADJUST as necessary.</li> <li>• ADJUST as necessary.</li> <li>• BALANCE tires.</li> </ul>
<ul style="list-style-type: none"> <li>• Rear Spring Squeak</li> </ul>	<ul style="list-style-type: none"> <li>• Rear spring(s).</li> <li>• Shackle bushing(s).</li> </ul>	<ul style="list-style-type: none"> <li>• INSTALL new rear spring anti-squeak inserts.</li> <li>• REPLACE as necessary.</li> </ul>

**SATISFACTION 100% GUARANTEED**

**BUY IT NOW!**

**Click Here To Order**

PayPal American Express Discover MasterCard VISA

**DIAGNOSIS AND TESTING (Continued)****Symptom Chart (Continued)**

Condition	Possible Source	Action
<ul style="list-style-type: none"> <li>Rough Ride</li> </ul>	<ul style="list-style-type: none"> <li>Shock absorber(s).</li> <li>Spring(s).</li> <li>Torsion bar(s).</li> </ul>	<ul style="list-style-type: none"> <li>GO to the Shock Absorber Inspection component test in this section.</li> <li>REPLACE as necessary. REFER to Section 204-01A (4x2) or Section 204-02.</li> <li>REPLACE as necessary. REFER to Section 204-01B (4x4).</li> </ul>
<ul style="list-style-type: none"> <li>Shimmy or Wheel Tramp</li> </ul>	<ul style="list-style-type: none"> <li>Loose lug nut(s).</li> <li>Loose front suspension fasteners.</li> <li>Front wheel bearing adjustment.</li> <li>Wheel or tire concerns.</li> <li>Spring(s).</li> <li>Torsion bar(s).</li> <li>Loose, worn or damaged ball joint(s).</li> <li>Loose, worn or damaged steering components.</li> <li>Front wheel alignment.</li> </ul>	<ul style="list-style-type: none"> <li>TIGHTEN to specification. REFER to Section 204-04.</li> <li>TIGHTEN to specification. REFER to Section 204-01A (4x2) or Section 204-01B (4x4).</li> <li>GO to the Wheel Bearing Inspection component test in this section.</li> <li>REFER to Section 204-04.</li> <li>REPLACE as necessary. REFER to Section 204-01A (4x2) or Section 204-02.</li> <li>REPLACE as necessary. REFER to Section 204-01B (4x4).</li> <li>GO to the Ball Joint Inspection component test in this section.</li> <li>REFER to Section 211-00.</li> <li>ADJUST as necessary.</li> </ul>
<ul style="list-style-type: none"> <li>Sticky Steering, Poor Returnability</li> </ul>	<ul style="list-style-type: none"> <li>Ball joints.</li> <li>Steering components.</li> </ul>	<ul style="list-style-type: none"> <li>GO to the Ball Joint Inspection component test in this section.</li> <li>REFER to Section 211-00.</li> </ul>
<ul style="list-style-type: none"> <li>Steering Wheel Off-Center</li> </ul>	<ul style="list-style-type: none"> <li>Unequal front or rear toe settings (side-to-side).</li> <li>Steering components.</li> </ul>	<ul style="list-style-type: none"> <li>ADJUST as necessary.</li> <li>REFER to Section 211-00.</li> </ul>
<ul style="list-style-type: none"> <li>Sway or Roll</li> </ul>	<ul style="list-style-type: none"> <li>Overloaded, unevenly or improperly loaded vehicle.</li> <li>Loose lug nut(s).</li> <li>Shock absorber(s).</li> <li>Loose stabilizer assembly.</li> <li>Worn stabilizer assembly bushing(s).</li> <li>Sagging torsion bar(s).</li> <li>Worn spring(s).</li> </ul>	<ul style="list-style-type: none"> <li>NOTIFY customer of improper vehicle loading.</li> <li>TIGHTEN to specification. REFER to Section 204-04.</li> <li>GO to the Shock Absorber Inspection component test in this section.</li> <li>TIGHTEN to specification. REFER to Section 204-01A (4x2), Section 204-01B (4x4) or Section 204-02.</li> <li>REPLACE as necessary. REFER to Section 204-01A (4x2), Section 204-01B (4x4) or Section 204-02.</li> <li>REPLACE as necessary. REFER to Section 204-01B (4x4).</li> <li>REPLACE as necessary. REFER to Section 204-01A (4x2) or Section 204-02.</li> </ul>



**BUY IT NOW!**

**Click Here To Order**



**DIAGNOSIS AND TESTING (Continued)****Symptom Chart (Continued)**

Condition	Possible Source	Action
<ul style="list-style-type: none"> <li>Vehicle Leans to One Side</li> </ul>	<ul style="list-style-type: none"> <li>Unevenly loaded or overloaded vehicle.</li> <li>Front or rear suspension components.</li> <li>Spring(s).</li> <li>Torsion bars.</li> <li>Incorrect drive axle(s) ride height. Lateral tilt out of specification.</li> <li>Suspension load leveling control system.</li> </ul>	<ul style="list-style-type: none"> <li>NOTIFY the customer of improper vehicle loading.</li> <li>INSPECT the front and rear suspension systems. REPAIR or REPLACE as necessary. REFER to Section 204-01A (4x2), Section 204-01B (4x4) or Section 204-02.</li> <li>REPLACE as necessary. REFER to Section 204-01A (4x2) or Section 204-02.</li> <li>REPLACE as necessary. REFER to Section 204-01B (4x4).</li> <li>INSPECT the front and rear suspension systems. ADJUST, REPAIR or REPLACE as necessary. REFER to Section 204-01B (4x4) or Section 204-02.</li> <li>REFER to suspension load leveling control system diagnosis and testing in Section 204-05.</li> </ul>
<ul style="list-style-type: none"> <li>Vibration/Noise</li> </ul>	<ul style="list-style-type: none"> <li>Tires and wheel concerns.</li> <li>Wheel bearings.</li> <li>Wheel hubs.</li> <li>Brake components.</li> <li>Suspension components.</li> <li>Steering components.</li> </ul>	<ul style="list-style-type: none"> <li>REFER to Section 100-04.</li> </ul>
<ul style="list-style-type: none"> <li>Wander</li> </ul>	<ul style="list-style-type: none"> <li>Unevenly loaded or overloaded vehicle.</li> <li>Ball joint(s).</li> <li>Loose, worn or damaged front wheel bearing(s).</li> <li>Loose, worn or damaged suspension components(s).</li> <li>Loose suspension fasteners.</li> <li>Steering components.</li> <li>Wheel alignment (excessive total front toe-out).</li> </ul>	<ul style="list-style-type: none"> <li>NOTIFY the customer of improper vehicle loading.</li> <li>GO to the Ball Joint Inspection component test in this section.</li> <li>GO to the Wheel Bearing Inspection component test in this section.</li> <li>REFER to Section 204-01A (4x2) or Section 204-01B (4x4).</li> <li>TIGHTEN to specification. REFER to Section 204-01A (4x2) or Section 204-01B (4x4).</li> <li>REFER to Section 211-00.</li> <li>ADJUST as necessary.</li> </ul>



**BUY IT NOW!**  
Click Here To Order



## DIAGNOSIS AND TESTING (Continued)

### Component Tests

#### Ball Joint Inspection

1.  **WARNING:** The electrical power to the air suspension system must be shut off prior to hoisting, jacking or towing an air suspension vehicle. This can be accomplished by turning off the air suspension switch located behind the RH kick panel area. Failure to do so can result in unexpected inflation or deflation of the air springs, which can result in shifting of the vehicle during these operations.

Raise and support the vehicle; for additional information, refer to Section 100-02.

2. Prior to performing any inspection of the ball joints, inspect the front wheel bearings (1216).
3. Position a safety stand beneath the front suspension lower arm (3079) to be tested.

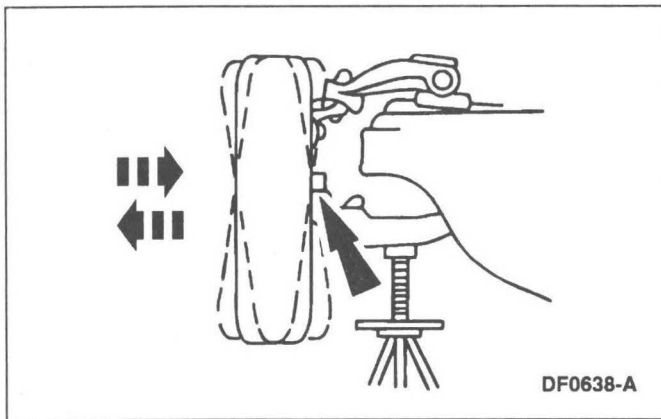

4. While an assistant pulls and pushes the bottom of the tire, observe the relative movement between the lower spindle arm and the front suspension lower arm ball joint. Any movement at or exceeding the specification indicates a worn or damaged lower ball joint. Replace as necessary; for additional information, refer to Section 204-01A or Section 204-01B.

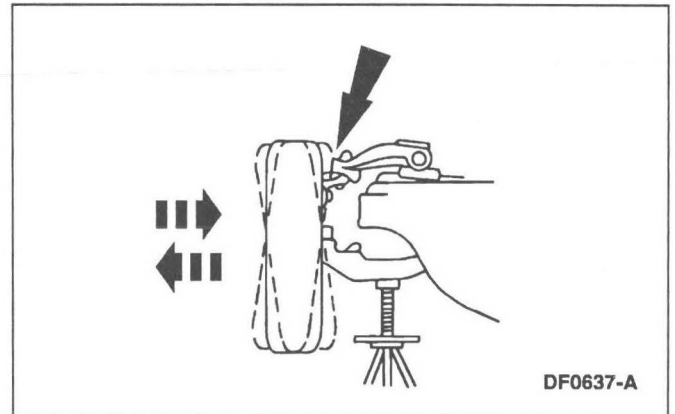

5. While an assistant pulls and pushes the top of the tire, observe the relative movement between the upper spindle arm and the front suspension lower arm ball joint (3050). Movement at or exceeding the specification indicates a worn or damaged upper ball joint. Replace the upper ball joint as necessary; for additional information, refer to Section 204-01A or Section 204-01B.

**100% SATISFACTION GUARANTEED**

**BUY IT NOW!**

**Click Here To Order**



## DIAGNOSIS AND TESTING (Continued)

### Shock Absorber Inspection

1.  **WARNING:** The electrical power to the air suspension system must be shut off prior to hoisting, jacking or towing an air suspension vehicle. This can be accomplished by turning off the air suspension switch located behind the RH kick panel area. Failure to do so can result in unexpected inflation or deflation of the air springs which can result in shifting of the vehicle during these operations.

 **WARNING:** The low pressure gas shock absorbers are charged with nitrogen gas to 931 kPa (135 psi) for 1-3/16 inch bore, and 1034 kPa (150 psi) for 1-3/8 inch bore. Do not attempt to open, puncture, or apply heat to the shock absorbers.

Raise and support the vehicle; for additional information, refer to Section 100-02.

2. Inspect for evidence of fluid leakage.
  - Leakage is a condition in which the shock absorber body is covered with oil. In severe cases, there may be oil dripping from the shock.
  - Weepage is a light film of oil on the shock absorber piston rod and is a result of proper shock lubrication. Weepage is a condition in which a thin film of oil is deposited on the upper portion of the shock body and is normally noticed due to the collection of dust in this area.
3. Inspect for damaged or worn shock absorber insulators.
4. Disconnect the lower end of the shock absorber.
5. Inspect the shock for proper operation.
  - 1 Compress and extend the shock absorber as fast as possible, using as much travel as possible.
  - 2 Inspect for the following abnormal conditions:
    - A lag or skip occurring during mid-stroke when the shock absorber is properly installed and primed.

- Any seizing during the shaft full travel, except at either end of the travel.
- Any noise, other than a faint swish, such as a clicking noise upon fast stroke reversal.
- Any lateral motion of the piston rod in relation to the body with the shock absorber fully extended.

6. Replace any unserviceable shock absorbers or shock absorber insulators.

### Wheel Bearing Inspection

1.  **WARNING:** The electrical power to the air suspension system must be shut off prior to hoisting, jacking or towing an air suspension vehicle. This can be accomplished by turning off the air suspension switch located behind the RH kick panel area. Failure to do so can result in unexpected inflation or deflation of the air springs, which can result in shifting of the vehicle during these operations.

Raise the vehicle until the tire is off the floor; for additional information, refer to Section 100-02.

2. **NOTE:** Make sure the wheel rotates freely and the brake pads are retracted sufficiently to allow movement of the tire and wheel assembly.
 

Grasp each front tire at the top and bottom and move the wheel inward and outward while lifting the weight of the tire off the front wheel bearing.
3. If the tire and wheel (hub) is loose on the wheel spindle or does not rotate freely, perform one of the following actions.
  - On 4x2 vehicles, adjust the front wheel bearings; for additional information, refer to Section 204-01A.
  - On 4x4 vehicles, replace the wheel hub (1104); for additional information, refer to Section 204-01B.

**100% SATISFACTION GUARANTEED**

**BUY IT NOW!**

**Click Here To Order**



## GENERAL PROCEDURES

### Camber and Caster Adjustment — 4x2

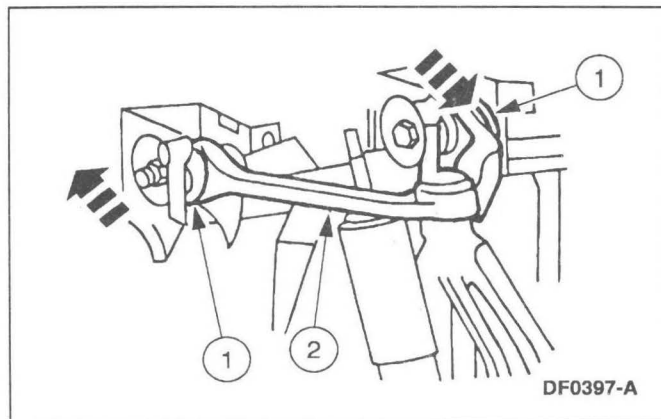
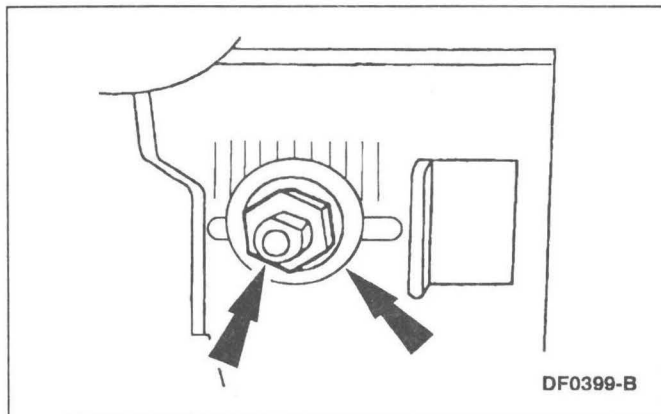
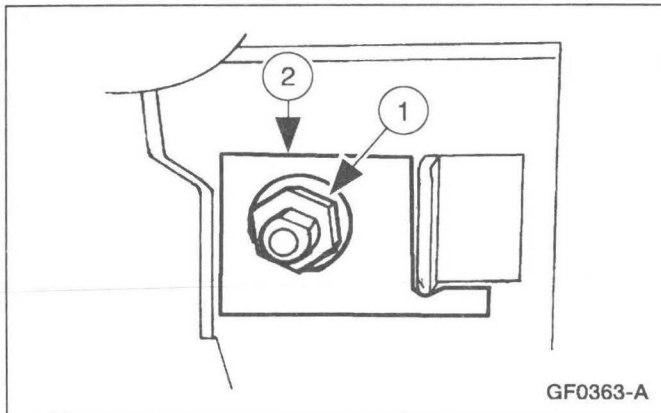

1. Remove the alignment plate.
  - 1 Remove the nuts.
  - 2 Remove the alignment plate.
  
2. Install the washers and the nuts.
  
3. **NOTE:** A pry bar can be used between the upper control arm and the frame pocket to aid in moving the arm.
 

To increase the caster and camber, use the following steps.

  - 1 To increase caster, move the front of the upper control arm outboard and move the rear of the upper control arm inboard.
  - 2 To increase camber, move the upper control arm outboard equally.

**100% SATISFACTION GUARANTEED**

**BUY IT NOW!**

**Click Here To Order**

## GENERAL PROCEDURES (Continued)

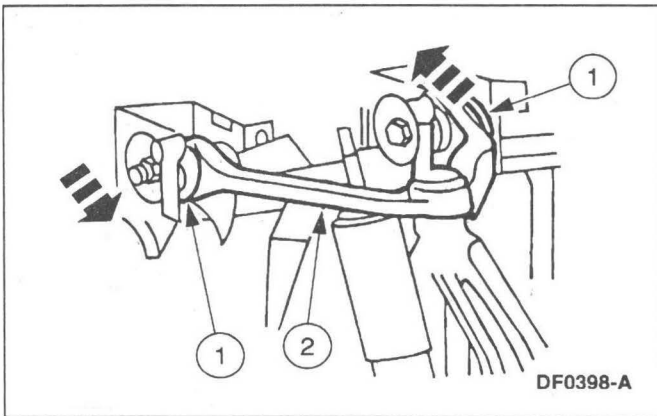

4. To decrease caster and camber, use the following steps.
  - 1 To decrease caster, move the front of the upper control arm inboard and move the rear of the upper control arm outboard.
  - 2 To decrease camber, move the upper control arm inboard equally.

5. **NOTE:** Each increment of the notches on the frame pocket represents 0.4 degree.

Set the caster and camber to specifications; for additional information, refer to Specifications in this section.

- If a caster increase of 1.2 degrees is required, move the front of the upper control arm outboard by 3 notches and move the rear of the upper control arm inboard by 3 notches.

6. Tighten the nuts.

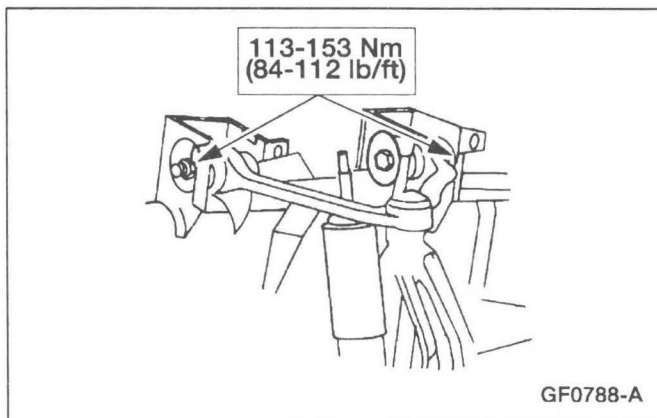

## Camber and Caster Adjustment — 4x4

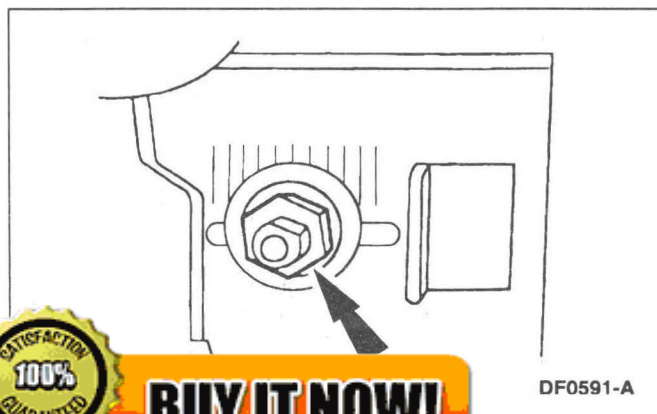

1. Loosen the nuts to a point where the upper suspension arm joints are snug.



**BUY IT NOW!**

**Click Here To Order**



## GENERAL PROCEDURES (Continued)

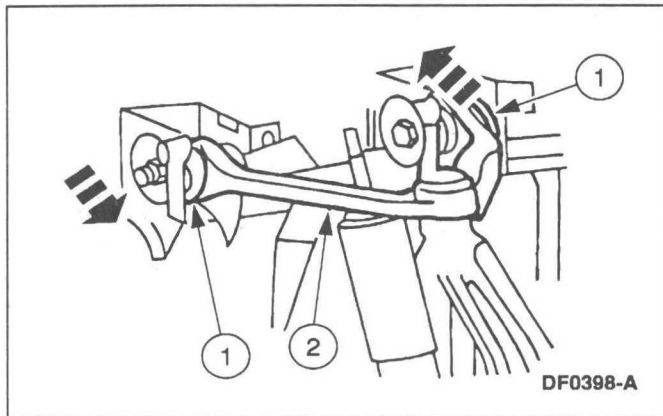
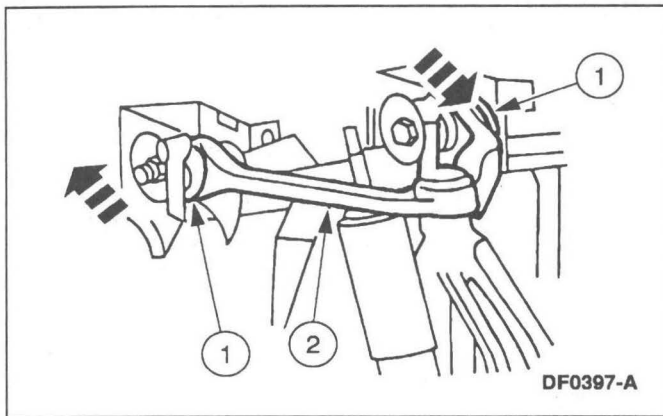

2. **NOTE:** A pry bar can be used between the upper control arm and the frame pocket to aid in moving the arm.

To increase caster and camber, use the following steps.

- 1 To increase caster, move the front of the upper control arm outboard and move the rear of the upper control arm inboard.
- 2 To increase camber, move the upper control arm outboard equally.

3. To decrease caster and camber, use the following steps.

- 1 To decrease caster, move the front of the upper control arm inboard and move the rear of the upper control arm outboard.
- 2 To decrease camber, move the upper control arm inboard equally.

4. **NOTE:** Each increment of the notches on the frame pocket represents 0.3 degree.

Set the caster and camber to specifications; refer to Specifications in this section.

- If a caster increase of 0.9 degree is required, move the front of the upper control arm outboard by 3 notches and move the rear of the upper control arm inboard by 3 notches.

5. Tighten the nuts.

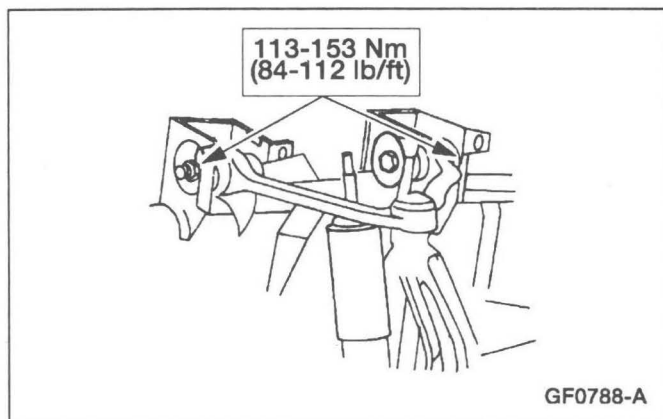

**100% SATISFACTION GUARANTEED**

**BUY IT NOW!**

**Click Here To Order**

## GENERAL PROCEDURES (Continued)

### Toe Adjustment

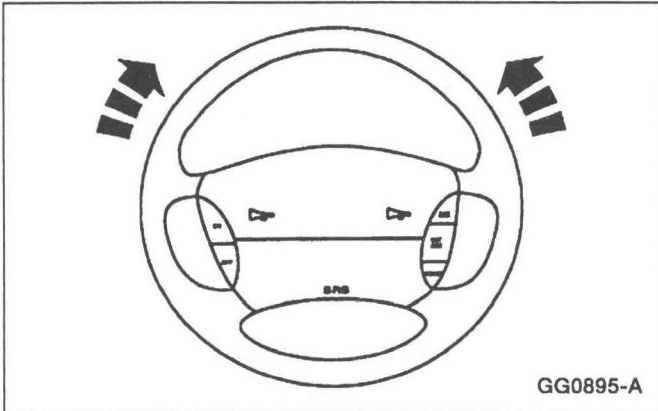

1. Start the engine (6007) and center the steering wheel (3600).

2. Turn the engine off, and hold the steering wheel in the “straight forward” position by attaching a rigid link from the steering wheel to the brake pedal.

3. Check the toe settings; follow the manufacturer’s instructions.

4. Hold the tie rod end (3A130) while loosening the nuts.
  - Clean and lubricate the steering linkage and tie rod end threads.

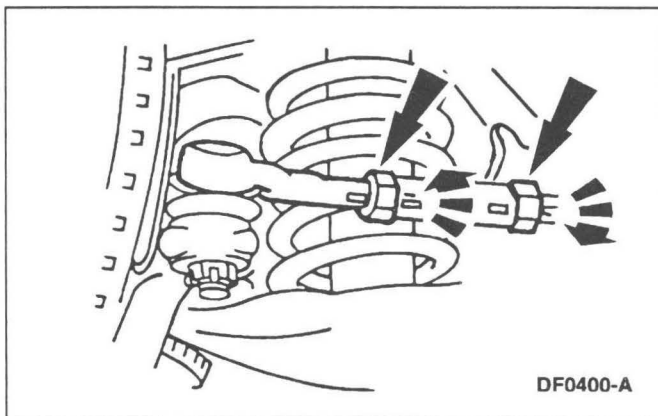

5. Rotate the front wheel spindle tie rod adjusting sleeve (3310) to the desired position.

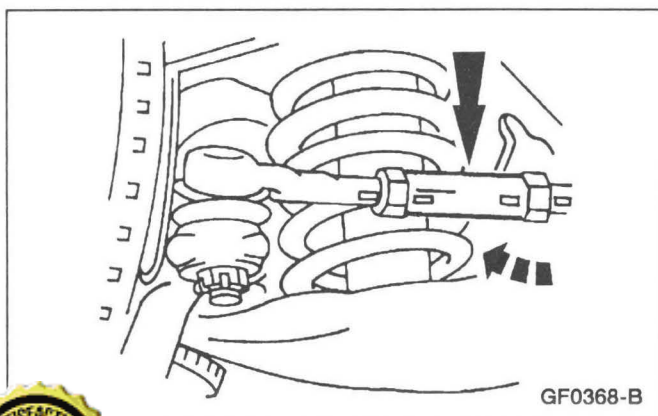

**BUY IT NOW!**

**Click Here To Order**



## GENERAL PROCEDURES (Continued)

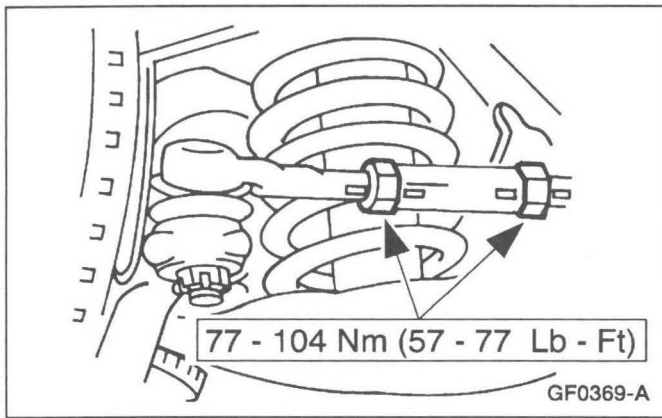

6. Tighten the nuts.

7. Recheck the toe settings; follow the manufacturer's instructions.

## SPECIFICATIONS

## General Specifications

Item	LH	RH	Total/Split
<b>Alignment Specifications — F-150, 4x2</b>			
Caster	6.2° ± 1.0°	6.7° ± 1.0°	-0.5° ± 0.7°
Camber	-0.3° ± 0.7°	-0.3° ± 0.7°	0° ± 0.7°
Toe (Positive value is toe-in, negative value is toe-out)	0.03° ± 0.15°	0.03° ± 0.15°	0.06° ± 0.25°
<b>Alignment Specifications — F-150, 4x4</b>			
Caster	4.6° ± 1.0°	5.3° ± 1.0°	-0.7° ± 0.7°
Camber	-0.1° ± 0.7°	-0.1° ± 0.7°	0° ± 0.7°
Toe (Positive value is toe-in, negative value is toe-out)	0.10° ± 0.15°	0.10° ± 0.15°	0.20° ± 0.25°
<b>Alignment Specifications — F-250, 4x2</b>			
Caster	5.9° ± 1.0°	6.4° ± 1.0°	-0.5° ± 0.7°
Camber	-0.3° ± 0.7°	-0.3° ± 0.7°	0° ± 0.7°
Toe (Positive value is toe-in, negative value is toe-out)	0.03° ± 0.15°	0.03° ± 0.15°	0.06° ± 0.25°

(Continued)

## General Specifications

Item	LH	RH	Total/Split
<b>Alignment Specifications — F-250, 4x2 w/Load Leveling Suspension</b>			
Caster	6.9° ± 1.0°	7.4° ± 1.0°	-0.5° ± 0.7°
Camber	-0.3° ± 0.7°	-0.3° ± 0.7°	0° ± 0.7°
Toe	0.03° ± 0.15°	0.03° ± 0.15°	0.06° ± 0.25°
<b>Alignment Specifications — F-250, 4x4</b>			
Caster	4.3° ± 1.0°	5.0° ± 1.0°	-0.7° ± 0.7°
Camber	-0.1° ± 0.7°	-0.1° ± 0.7°	0° ± 0.7°
Toe (Positive value is toe-in, negative value is toe-out)	0.10° ± 0.15°	0.10° ± 0.15°	0.20° ± 0.25°
<b>Alignment Specifications — F-250, 4x4, w/Load Leveling Suspension</b>			
Caster	5.3° ± 1.0°	6.0° ± 1.0°	-0.7° ± 0.7°
Camber	-0.1° ± 0.7°	-0.1° ± 0.7°	0° ± 0.7°
Toe	0.10° ± 0.15°	0.10° ± 0.15°	0.20° ± 0.25°

**SATISFACTORY 100% GUARANTEED**

**BUY IT NOW!**

**Click Here To Order**

PayPal Discover NEWUS MasterCard VISA

**SPECIFICATIONS (Continued)****General Specifications**

Item	Specification
Dogtracking — Maximum (Centerline of front tires compared to centerline of rear tires)	30 mm (1.2 in.)
<b>Clear Vision</b>	
Clear Vision (Negative value is counterclockwise)	-0.7° ± 3.0°
<b>Vehicle Ride Height — F-150, 4x2</b>	
Front — Regular Cab	114 mm ± 20 mm (4.5 in. ± 0.8 in.)
Front — Super Cab	122 mm ± 20 mm (4.8 in. ± 0.8 in.)
Rear	153 mm - 215 mm (6.0 in. - 8.5 in.)
<b>Vehicle Ride Height — F-150, 4x4</b>	
Front — Regular and Super Cabs	113 mm ± 19 mm (4.4 in. ± 0.75 in.)
Rear	150 mm - 205 mm (5.9 in. - 8.1 in.)
<b>Vehicle Ride Height — F-250, 4x2</b>	
Front — Regular Cab	114 mm ± 20 mm (4.5 in. ± 0.8 in.)
Front — Super Cab	122 mm ± 20 mm (4.8 in. ± 0.8 in.)
Rear	173 mm - 235 mm (6.8 in. - 9.25 in.)
<b>Vehicle Ride Height — F-250, 4x2, w/Load Leveling Suspension</b>	
Front — Regular Cab	114 mm ± 20 mm (4.5 in. ± 0.8 in.)
Front — Super Cab	122 mm ± 20 mm (4.8 in. ± 0.8 in.)

(Continued)

**General Specifications**

Item	Specification
Rear	83 mm - 101 mm (3.3 in. - 4.0 in.)
<b>Vehicle Ride Height — F-250, 4x4</b>	
Front — Regular and Super Cabs	113 mm ± 19 mm (4.4 in. ± 0.75 in.)
Rear	170 mm - 225 mm (6.7 in. - 8.9 in.)
<b>Vehicle Ride Height — F-250, 4x4, w/Load Leveling Suspension</b>	
Front — Regular and Super Cabs	113 mm ± 19 mm (4.4 in. ± 0.75 in.)
Rear	80 mm - 98 mm (3.1 in. - 3.9 in.)
<b>Ball Joint Radial Play</b>	
Lower Ball Joint — Maximum	0.8 mm (1/32 in.)
Upper Ball Joint — Maximum	0.8 mm (1/32 in.)
<b>Vehicle Lean (Side-to-Side Height Differences)</b>	
Front — Maximum	12 mm (0.5 in.)
Rear — Maximum	19 mm (0.75 in.)

**Torque Specifications**

Description	Nm	Lb-Ft
Front Suspension Upper Arm Cam Bolt	113-153	84-112
Toe Set Jam Nuts	77-104	57-77

**100% SATISFACTION GUARANTEED**

**BUY IT NOW!**

**Click Here To Order**

# SECTION 204-01A Front Suspension — 4x2

VEHICLE APPLICATION: F-150/F-250

CONTENTS	PAGE
<b>DESCRIPTION AND OPERATION</b>	
Front Suspension .....	204-01A-2
<b>DIAGNOSIS AND TESTING</b>	
Front Suspension .....	204-01A-4
<b>REMOVAL AND INSTALLATION</b>	
Arm — Lower .....	204-01A-5
Arm — Upper .....	204-01A-10
Bar and Link .....	204-01A-14
Spindle .....	204-01A-16
Spring — Coil .....	204-01A-22
Wheel Studs .....	204-01A-4
<b>SPECIFICATIONS</b> .....	204-01A-26

**100% SATISFACTION GUARANTEED**

**BUY IT NOW!**

**Click Here To Order**

PayPal American Express Discover MasterCard VISA

# DESCRIPTION AND OPERATION

## Front Suspension

### Front Suspension Components

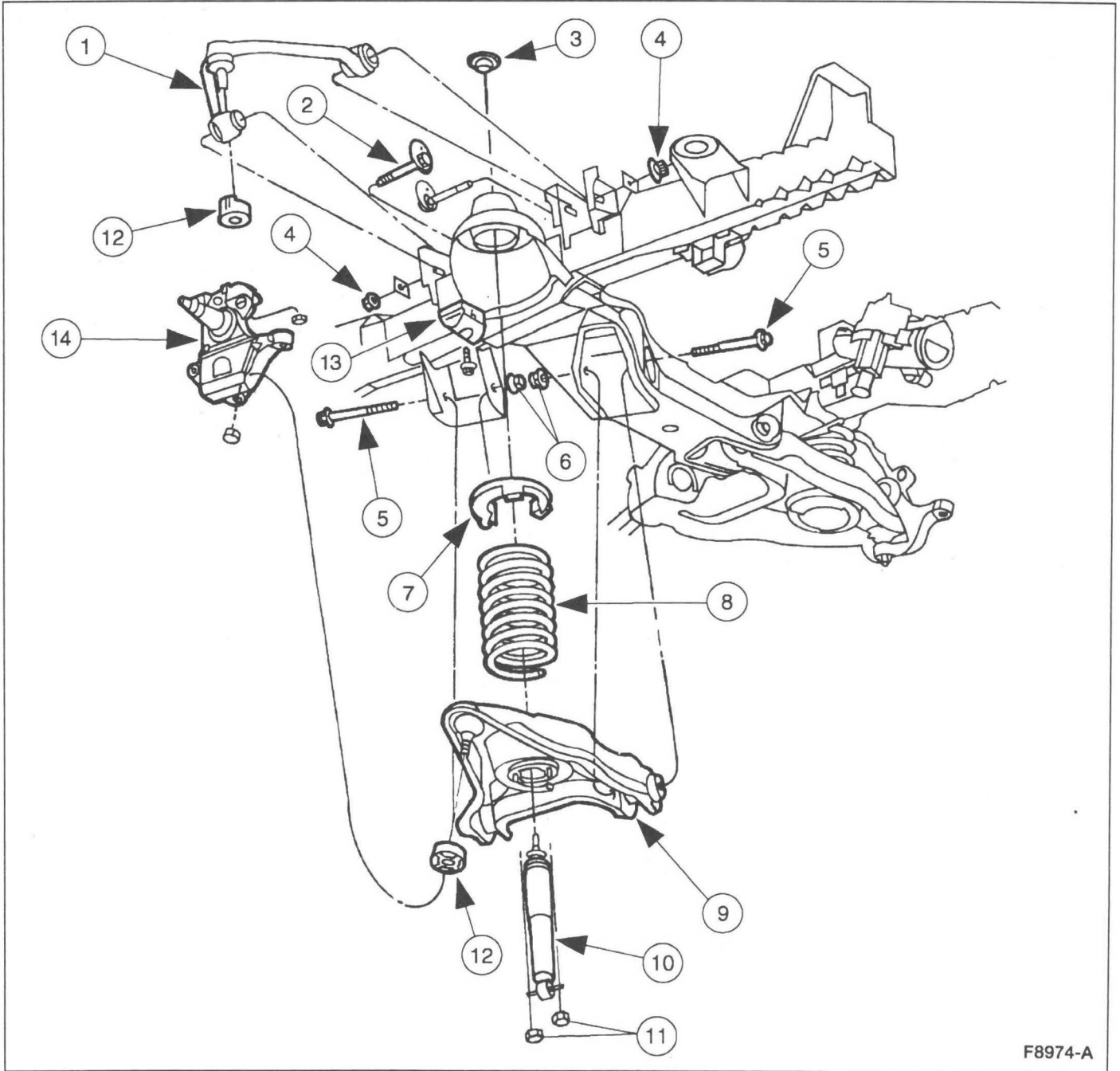

F8974-A

Item	Part Number	Description
1	3082	Front Suspension Upper Arm
2	3C178	Front Suspension Upper Arm Cams
3		Upper Insulator Assy
4		Lower Control Arm Nut

Item	Part Number	Description
5	—	Front Suspension Lower Arm Bolt
6	—	Front Suspension Lower Arm Nut
7	5415	Front Spring Insulator

(Continued)

**100% SATISFACTION GUARANTEED**

**BUY IT NOW!**

**Click Here To Order**

**DESCRIPTION AND OPERATION (Continued)**

Item	Part Number	Description
8	5310	Front Coil Spring
9	3079	Front Suspension Lower Arm
10	18124	Front Shock Absorber
11	—	Shock Absorber Nut

Item	Part Number	Description
12	—	Ball Joint Shield
13	3020	Front Suspension Bumper
14	3105	Front Wheel Spindle

(Continued)

**Front Stabilizer Bar Components**

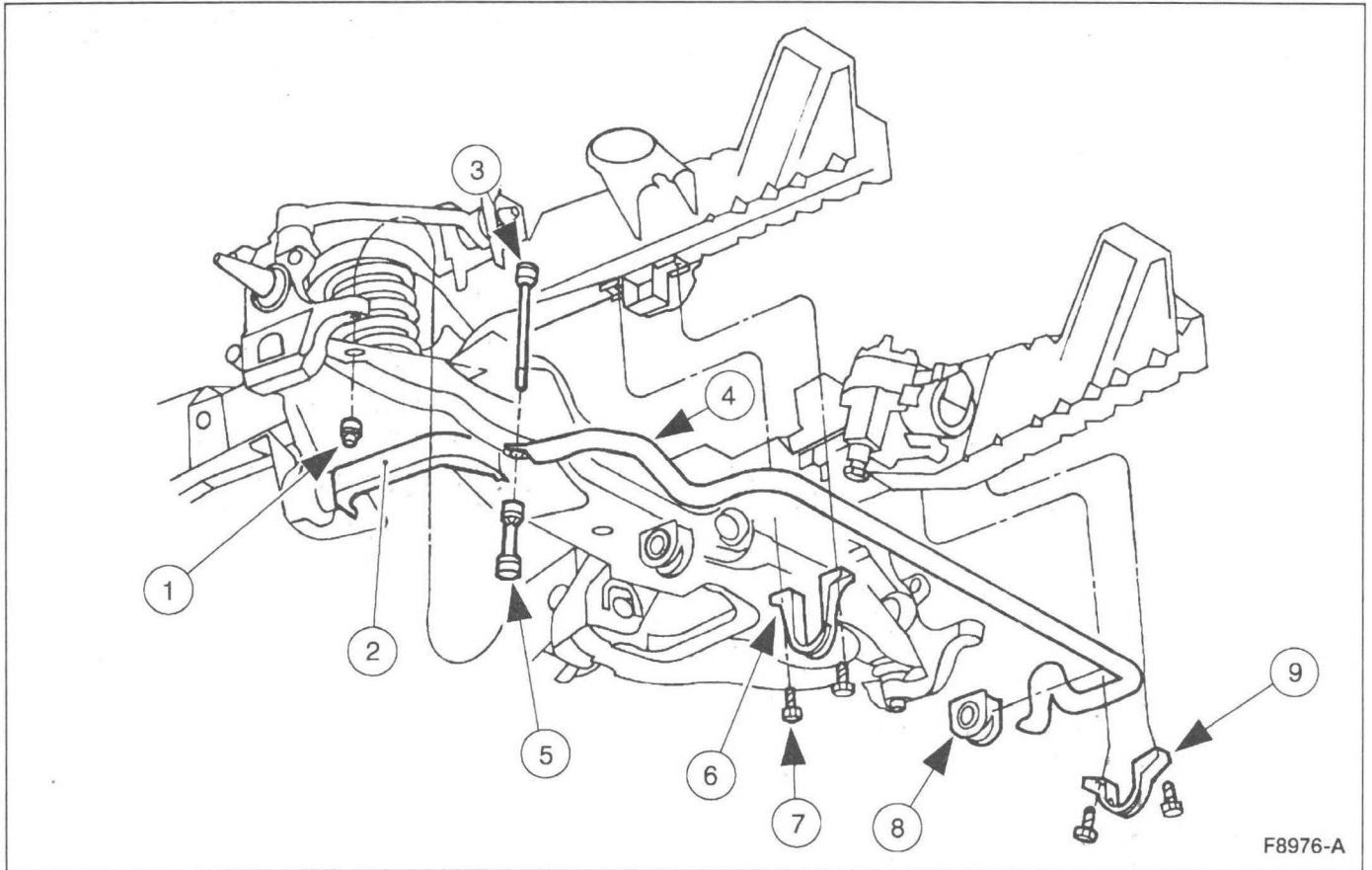

Item	Part Number	Description
1	—	Front Stabilizer Bar Link Nut
2	3079	Front Suspension Lower Arm
3	—	Front Stabilizer Bar Link Bolt
4	5482	Front Stabilizer Bar
5	5K483	Front Stabilizer Bar Link

Item	Part Number	Description
6	5486	Stabilizer Bar Bracket
7	—	Front Stabilizer Bar Bracket Bolt
8	5493	Lower Suspension Arm Stabilizer Bar Insulator
9	5486	Stabilizer Bar Bracket

(Continued)

**100% SATISFACTION GUARANTEED**

**BUY IT NOW!**

**Click Here To Order**

## DIAGNOSIS AND TESTING

### Front Suspension

Refer to Section 204-00.

## REMOVAL AND INSTALLATION

### Wheel Studs

#### Removal

 **WARNING:** The electrical power to the air suspension system must be turned off prior to hoisting, jacking or towing an air suspension vehicle. Failure to do so can result in unexpected inflation or deflation of the air springs, which can result in shifting of the vehicle during these operations.

1. If equipped, turn the air suspension service switch off.
2. Raise the vehicle on a hoist; for additional information, refer to Section 100-02.
3. Remove the wheel and tire assembly; for additional information, refer to Section 204-04.
4. Remove the front disc brake hub and brake disc (1102); refer to Section 206-03.

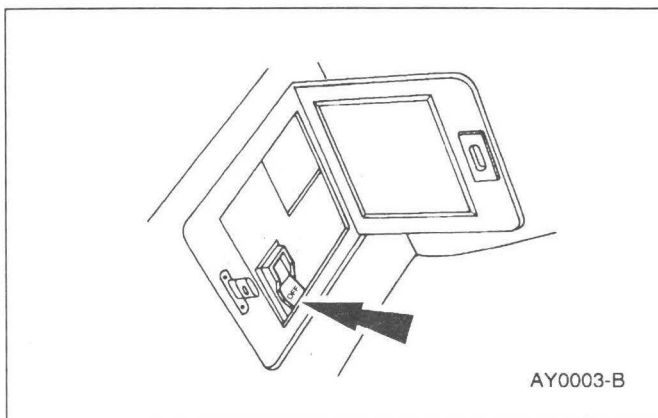

**100% SATISFACTION GUARANTEED**

**BUY IT NOW!**

**Click Here To Order**

PayPal | American Express | Discover | MasterCard | VISA

**REMOVAL AND INSTALLATION (Continued)**

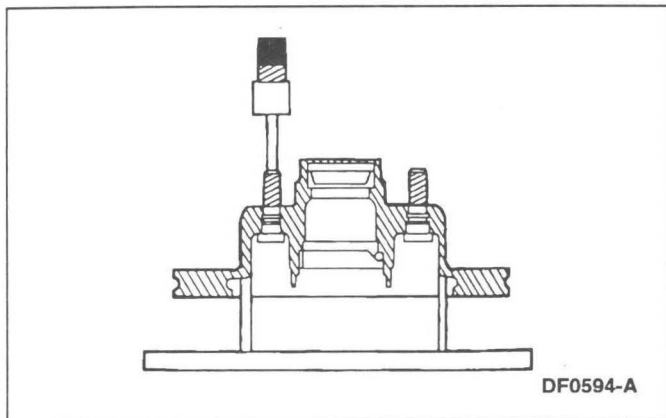

- Using a suitable press, remove the wheel stud (1107) from the front disc brake hub and brake disc.

**Installation**

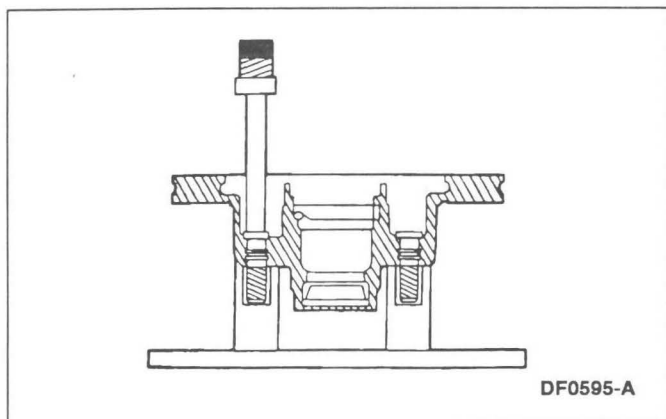

- Follow the removal procedure in reverse order.

**Arm — Lower**

**Special Tool(s)**

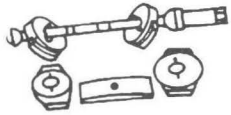
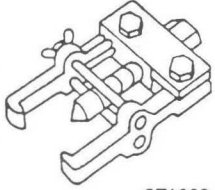
 <p>ST1352-A</p>	<p>Coil Spring Compressor 204-D001 (D78P-5310-A) or Equivalent</p>
 <p>ST1263-A</p>	<p>Pitman Arm Puller 211-003 (T64P-3590-F)</p>

**100% SATISFACTION GUARANTEED**

**BUY IT NOW!**

**Click Here To Order**



## REMOVAL AND INSTALLATION (Continued)

## Removal

1.  **WARNING:** The electrical power to the air suspension system must be shut off prior to hoisting, jacking or towing an air suspension vehicle. This can be accomplished by turning off the air suspension switch located in the RH kick panel area. Failure to do so can result in unexpected inflation or deflation of the air springs, which can result in shifting of the vehicle during these operations.

Raise the vehicle on a hoist; for additional information, refer to Section 100-02.

2. Remove the wheel and tire assembly; for additional information, refer to Section 204-04.
3. Remove the brake disc shield (2K004); for additional information, refer to Section 206-03.
4. Remove the upper shock absorber nut and washer.

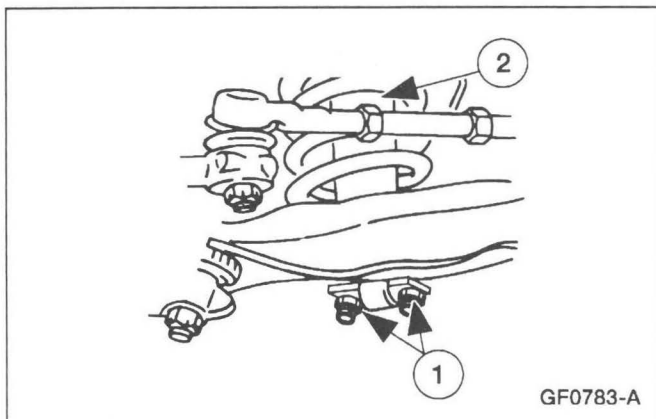
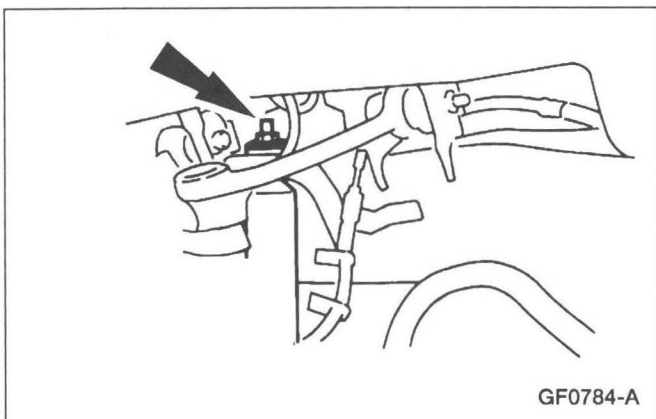

5. Remove the front shock absorber (18124).
  - 1 Remove the nuts.
  - 2 Remove the shock absorber.

**100% SATISFACTION GUARANTEED**

**BUY IT NOW!**

**Click Here To Order**

PayPal | American Express | Discover | MasterCard | VISA

## REMOVAL AND INSTALLATION (Continued)

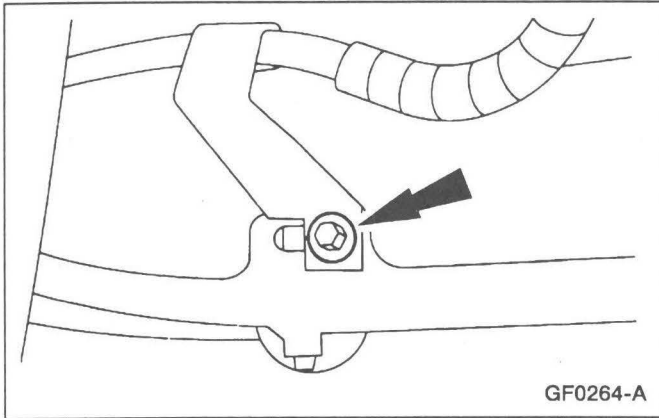

6. Remove the brake hose bracket screw and bracket from the front suspension lower arm (3079).

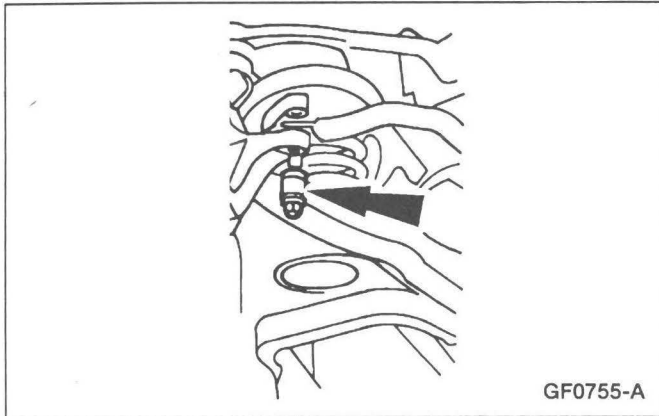

7. Remove the front stabilizer bar link nut.

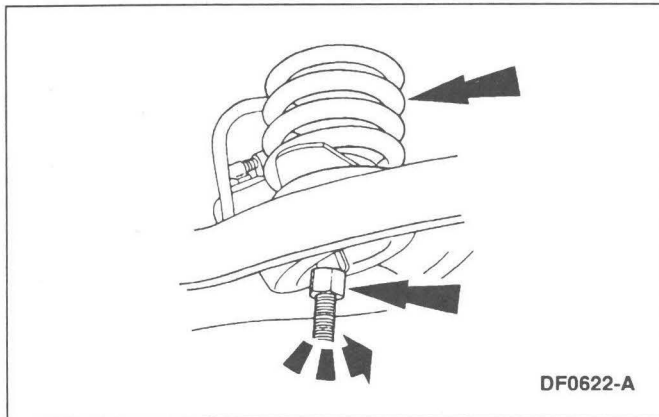

8. Use the Coil Spring Compressor to compress the coil spring.

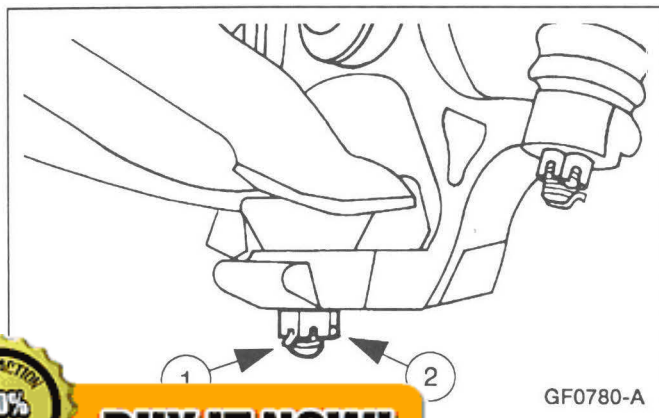

9. Remove the lower ball joint castellated nut.
  - 1 Remove the cotter pin.
  - 2 Remove the castellated nut.



**BUY IT NOW!**

**Click Here To Order**

PayPal

Discover  
Cards

DISCOVER  
NEWUS

MasterCard

VISA

## REMOVAL AND INSTALLATION (Continued)

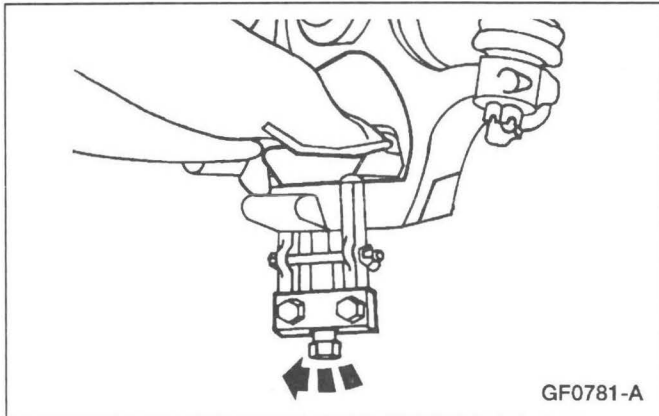

10. Use the Pitman Arm Puller to separate the lower ball joint from the front wheel spindle (3105).

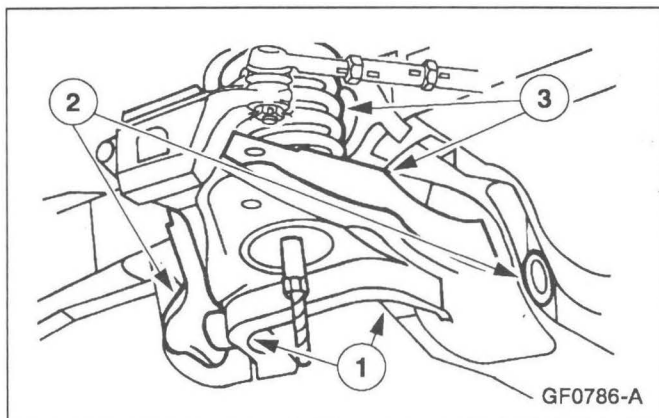

11. Remove the front suspension lower arm (3078) and front coil spring (5310).
  - 1 Remove the front suspension lower arm nuts.
  - 2 Remove the front suspension lower arm bolts.
  - 3 Remove the front suspension lower arm and front coil spring.

## Installation

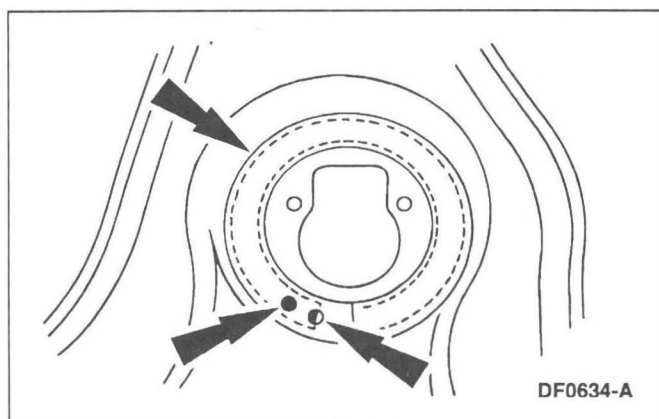

1. **NOTE:** The end of the coil spring must cover the first hole and be visible in the second hole.  
Install the front coil spring into the front suspension lower arm.



2. **NOTE:** The forward front suspension lower arm nut must be tightened first while the control arm is held at the curb position ride height.  
Install the front suspension lower arm.
  - 1 Position the front suspension lower arm and front coil spring.
  - 2 Install the bolts and nuts.



**BUY IT NOW!**

**Click Here To Order**

/ft)

F8991-C



## REMOVAL AND INSTALLATION (Continued)

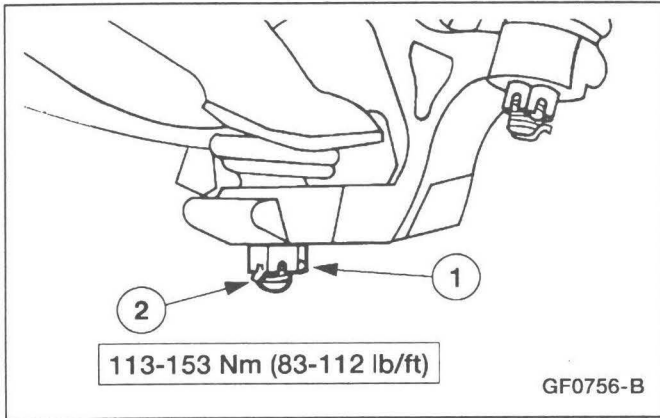

3. Install the lower ball joint.
  - 1 Install the castellated nut.
  - 2 Install a new cotter pin.

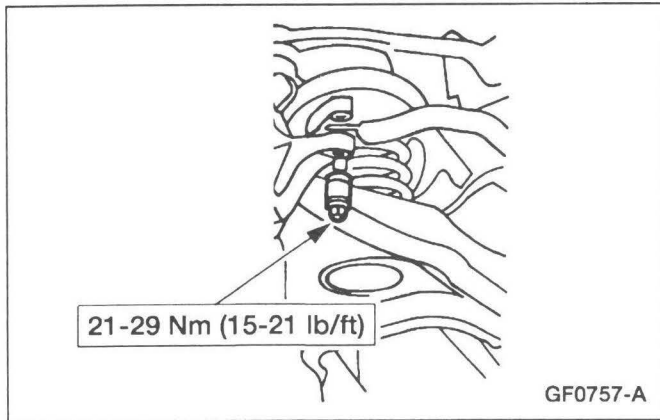

4. Install the front stabilizer bar link nut.

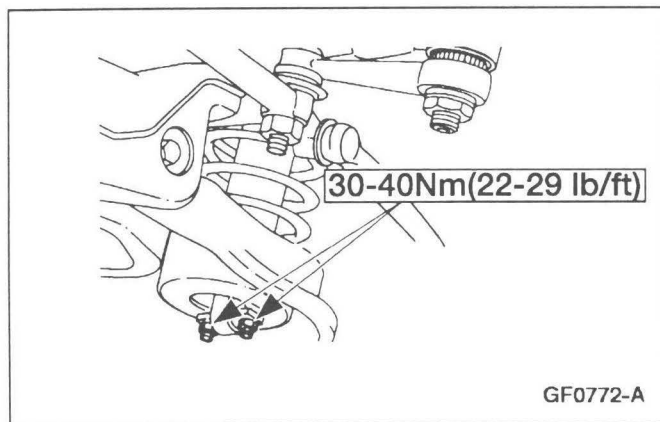

5. Remove the Coil Spring Compressor.
6. Install the front shock absorber and the shock absorber lower nuts.

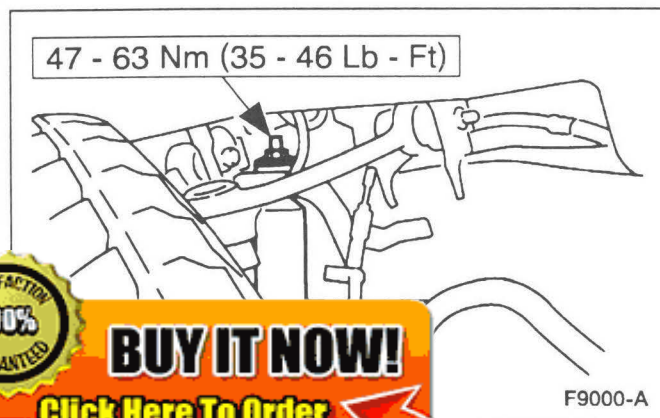

7. Install the upper shock absorber washer and nut.

**100% SATISFACTION GUARANTEED**

**BUY IT NOW!**

**Click Here To Order**

## REMOVAL AND INSTALLATION (Continued)

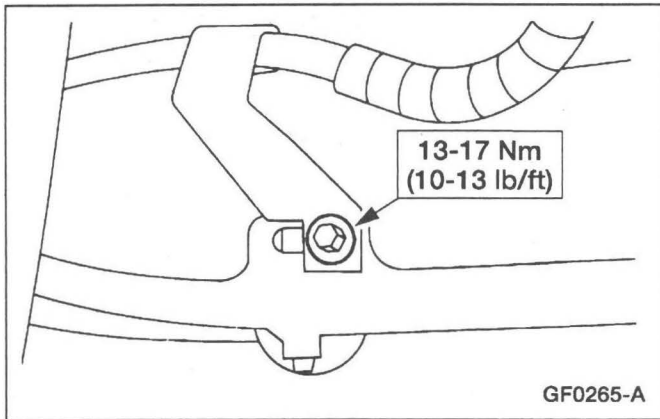

8. Install the brake hose bracket screw.
9. Install the brake disc shield; for additional information, refer to Section 206-03.
10. **NOTE:** If equipped with air suspension, reactivate the system by turning on the air suspension switch.  
Install the tire and wheel assembly; for additional information, refer to Section 204-04.
11. Inspect and adjust the front end alignment; for additional information, refer to Section 204-00.

## Arm — Upper

## Special Tool(s)

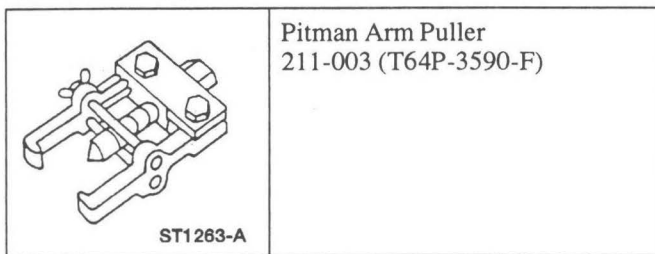

**100% SATISFACTION GUARANTEED**

**BUY IT NOW!**

**Click Here To Order**

## REMOVAL AND INSTALLATION (Continued)

## Removal

1.  **WARNING:** The electrical power to the air suspension system must be shut off prior to hoisting, jacking or towing an air suspension vehicle. This can be accomplished by turning off the air suspension switch located in the RH kick panel area. Failure to do so can result in unexpected inflation or deflation of the air springs, which can result in shifting of the vehicle during these operations.

Raise the vehicle on a hoist; for additional information, refer to Section 100-02.

2. Remove the wheel and tire assembly; for additional information, refer to Section 204-04.
3. Use a suitable jack to support the front suspension lower arm (3079).

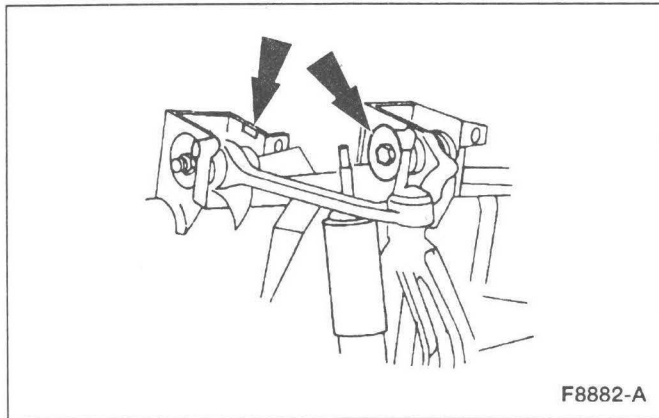
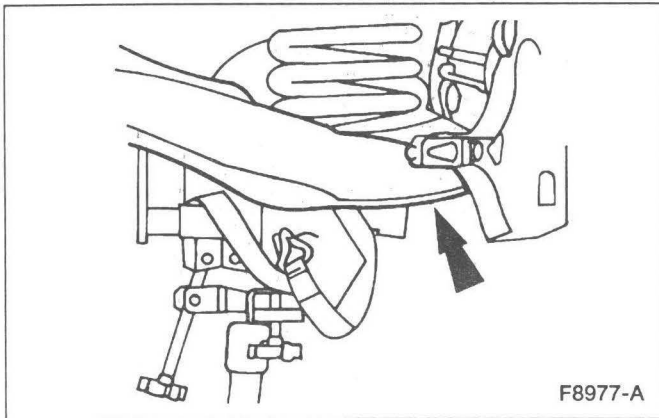

4. Mark the position of the front suspension upper arm cam (3C178).

**100% SATISFACTION GUARANTEED**

**BUY IT NOW!**

**Click Here To Order**



## REMOVAL AND INSTALLATION (Continued)

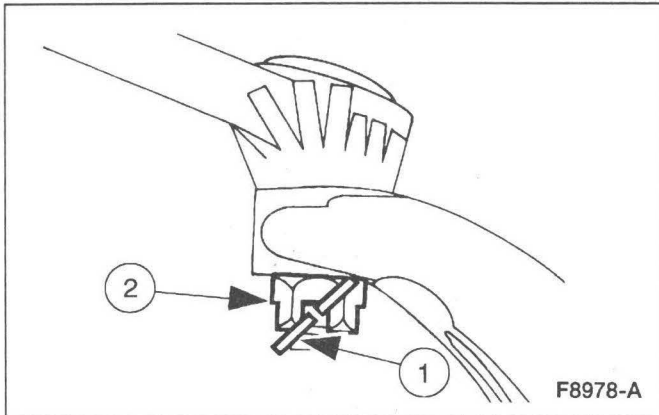

5. Remove the upper ball joint castellated nut.
  - 1 Remove the cotter pin.
  - 2 Remove the nut.

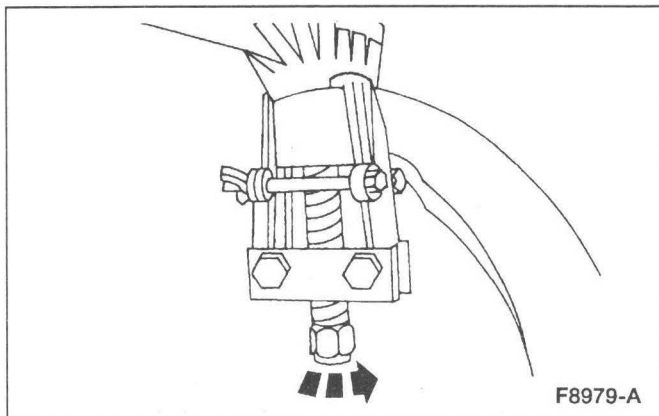

6. Use the Pitman Arm Puller to separate the ball joint from the front wheel spindle (3105).

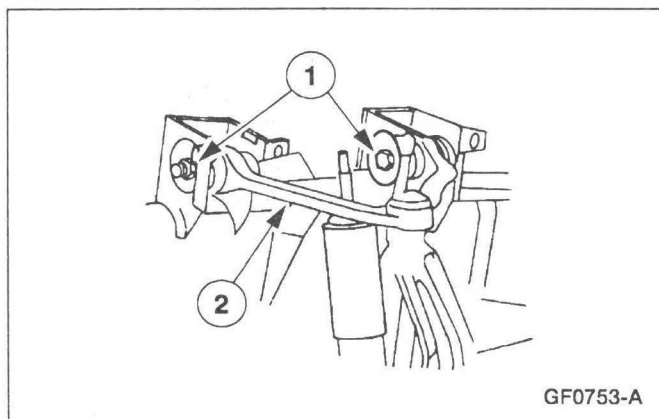

7. Remove the front suspension upper arm.
  - 1 Remove the two nuts and the two bolts.
  - 2 Remove the front suspension upper arm (3082).

## Installation



1. Align the marks made during removal on the front suspension upper arm cams.

**100% SATISFACTION GUARANTEED**

**BUY IT NOW!**

**Click Here To Order**

## REMOVAL AND INSTALLATION (Continued)

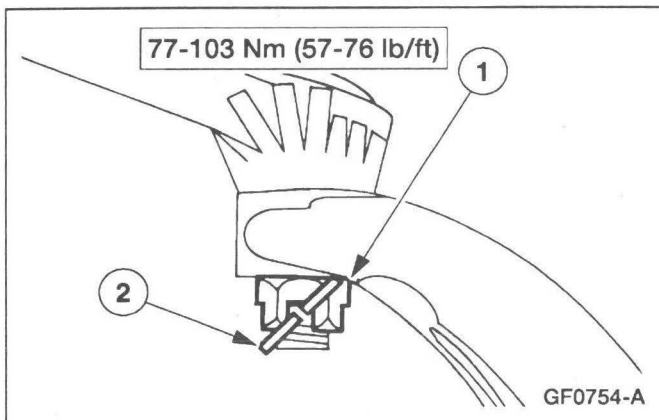
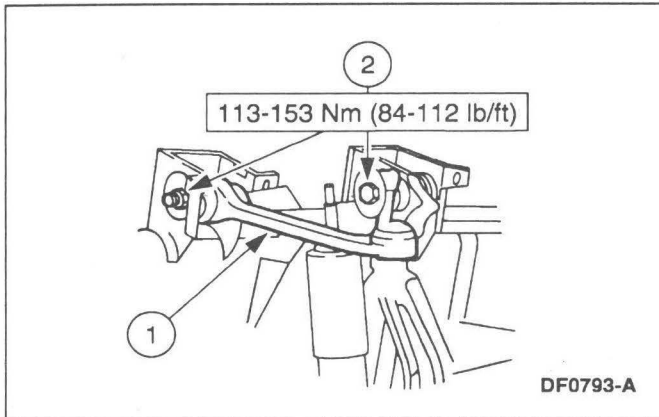

2. **NOTE:** The forward front suspension upper arm nut must be tightened first while the control arms are held at the curb position ride height.

Install the front suspension upper arm.

- 1 Position the front suspension upper arm.
- 2 Install the two bolts and nuts.

3. Install the upper ball joint castellated nut.

- 1 Install the nut.
- 2 Install a new cotter pin.

4. **NOTE:** If equipped with air suspension, reactivate the system by turning on the air suspension switch.

Install the tire and wheel assembly; for additional information, refer to Section 204-04.

5. Inspect and adjust the front end alignment; for additional information, refer to Section 204-00.

**100% SATISFACTION GUARANTEED**

**BUY IT NOW!**

**Click Here To Order**

PayPal American Express Cards DISCOVER NOVUS MasterCard VISA

## REMOVAL AND INSTALLATION (Continued)

## Bar and Link

## Removal

1.  **WARNING:** The electrical power to the air suspension system must be shut off prior to hoisting, jacking, or towing an air suspension vehicle. This can be accomplished by turning off the air suspension switch located in the RH kick panel area. Failure to do so can result in unexpected inflation or deflation of the air springs, which can result in shifting of the vehicle during these operations.

Raise the vehicle on a hoist; for additional information, refer to Section 100-02.

2. Remove the wheel and tire assembly; for additional information, refer to Section 204-04.
3. Remove the front stabilizer bar link nuts from the front suspension lower arms (3078).

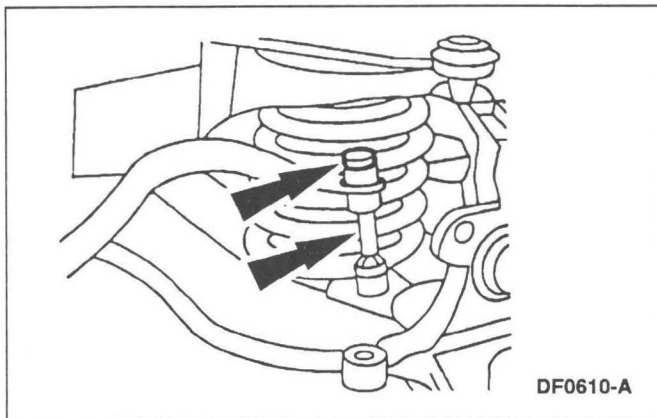
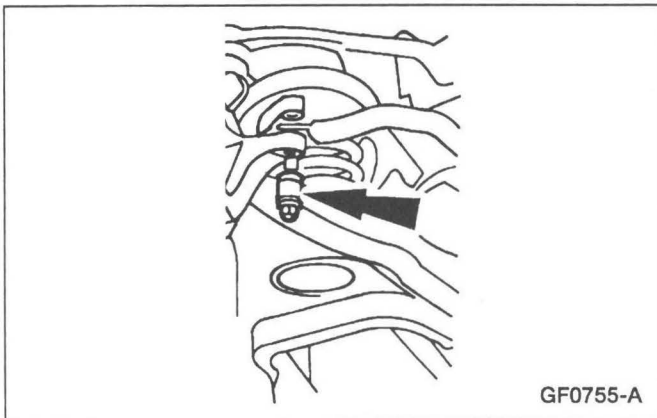

4. Remove the front stabilizer bar link bolts and remove the front stabilizer bar links.

**100% SATISFACTION GUARANTEED**

**BUY IT NOW!**

**Click Here To Order**



### REMOVAL AND INSTALLATION (Continued)

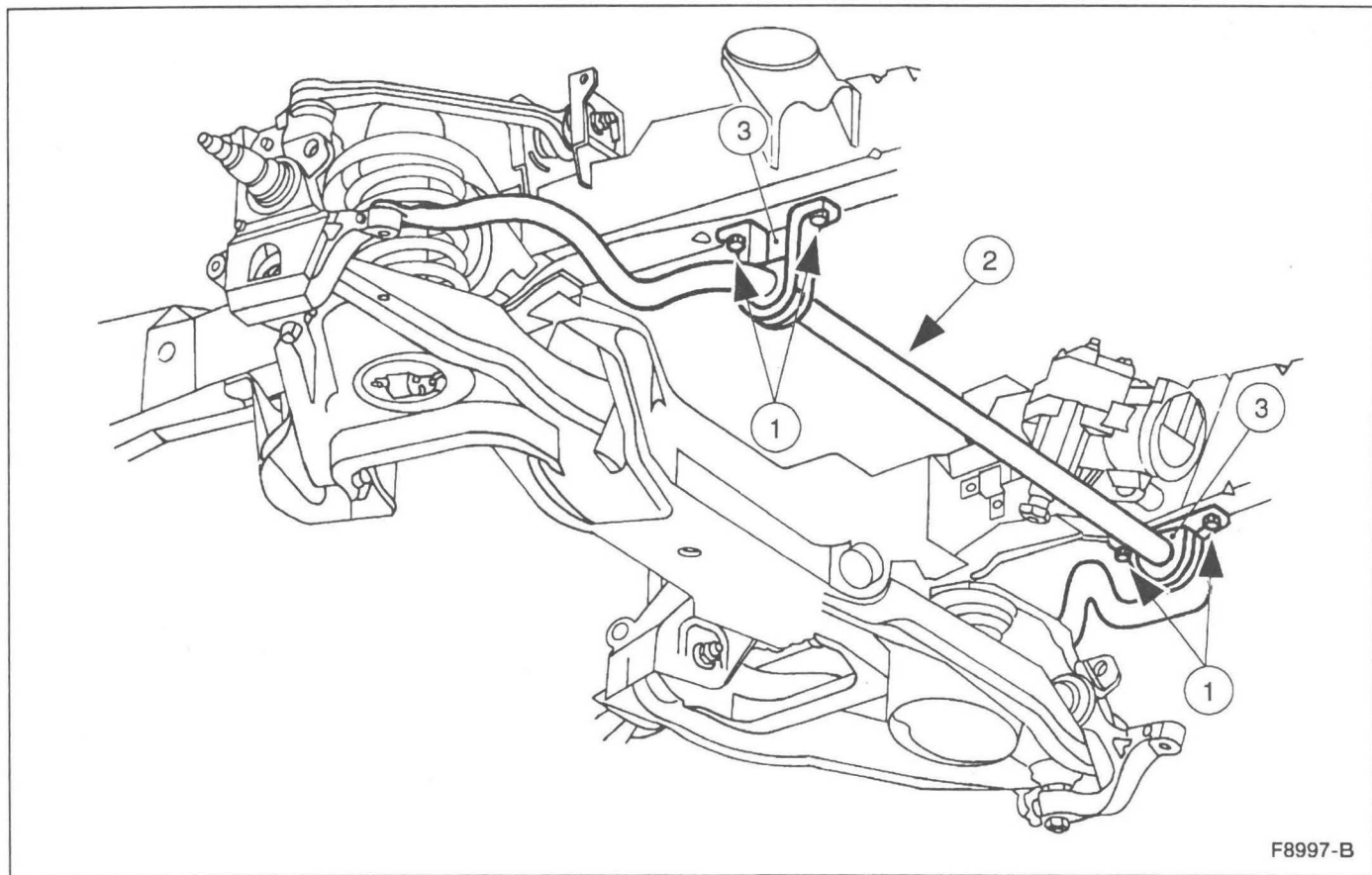

5. Remove the front stabilizer bar (5482).
  - 1 Remove the four bolts.
  - 2 Remove the front stabilizer bar.
  - 3 Remove the lower suspension arm stabilizer bar insulators.

### Installation

1. Follow the removal procedure in reverse order.

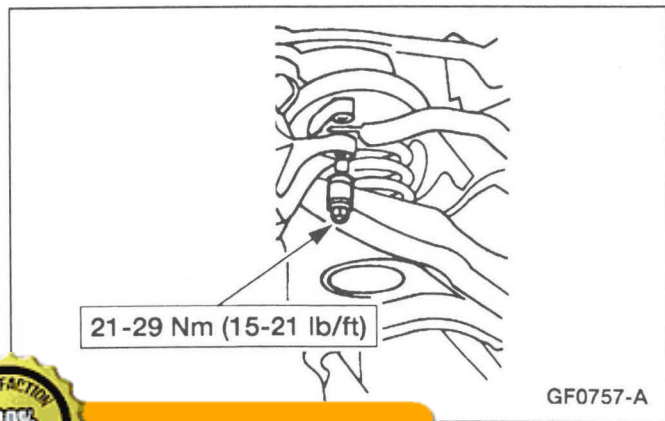

**BUY IT NOW!**

**Click Here To Order**



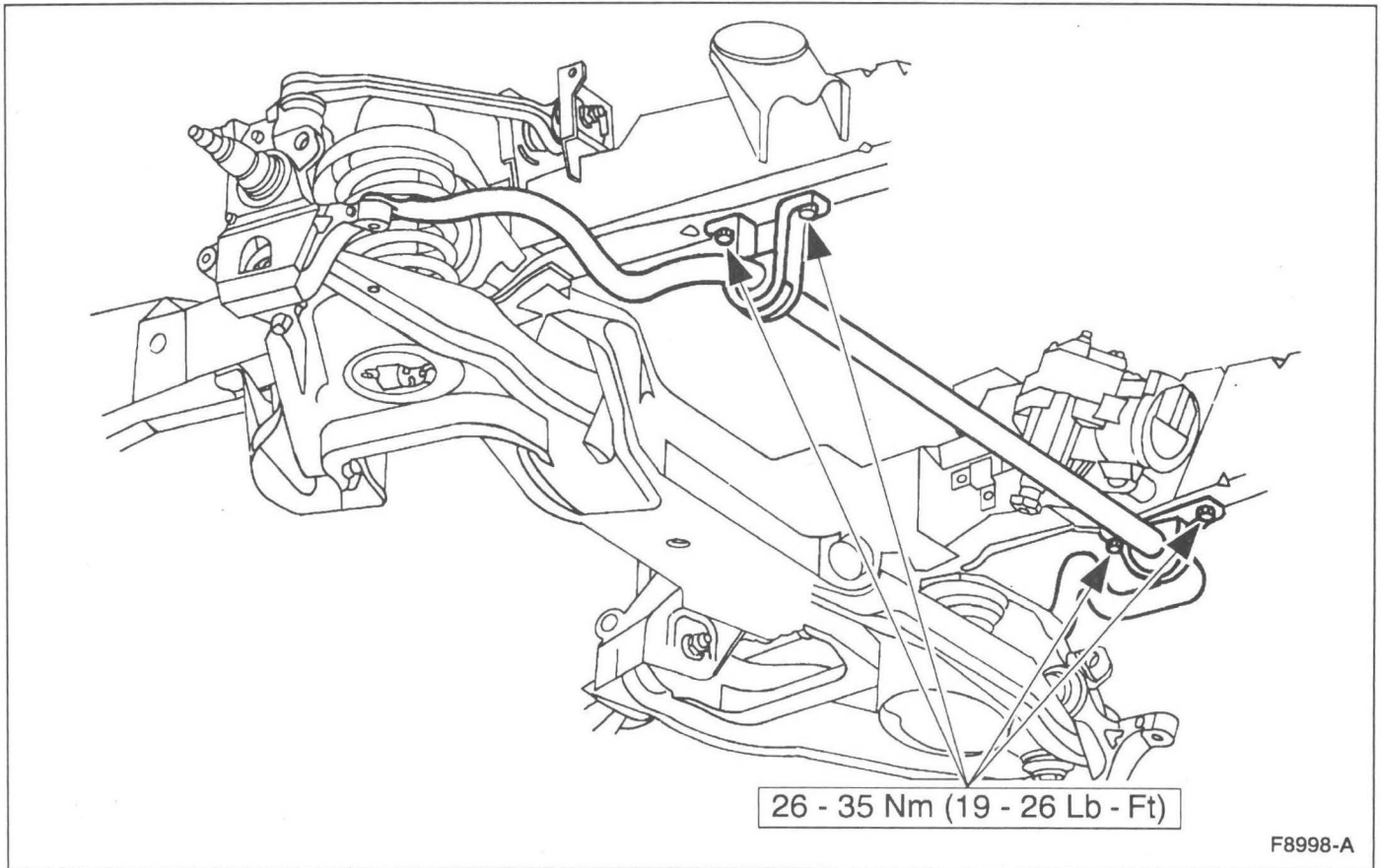

## REMOVAL AND INSTALLATION (Continued)

- If equipped with air suspension, lower the vehicle and reactivate the system by turning on the air suspension switch.

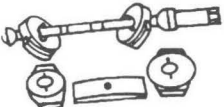

## Spindle

## Special Tool(s)

 <p>ST1352-A</p>	<p>Coil Spring Compressor 204-D001 (D78P-5310-A) or Equivalent</p>
	<p>Pitman Arm Puller 211-003 (T64P-3590-F)</p>



**BUY IT NOW!**

**Click Here To Order**



## REMOVAL AND INSTALLATION (Continued)

## Removal

1.  **WARNING:** The electrical power to the air suspension system must be shut off prior to hoisting, jacking, or towing an air suspension vehicle. This can be accomplished by turning off the air suspension switch located in the RH kick panel area. Failure to do so can result in unexpected inflation or deflation of the air springs, which can result in shifting of the vehicle during these operations.

Raise the vehicle on a hoist; for additional information, refer to Section 100-02.

2. Remove the wheel and tire assembly; for additional information, refer to Section 204-04.
3. Remove the brake disc shield (2K004) ; for additional information, refer to Section 206-03.
4. Use a suitable jack to support the front suspension lower arm (3078).

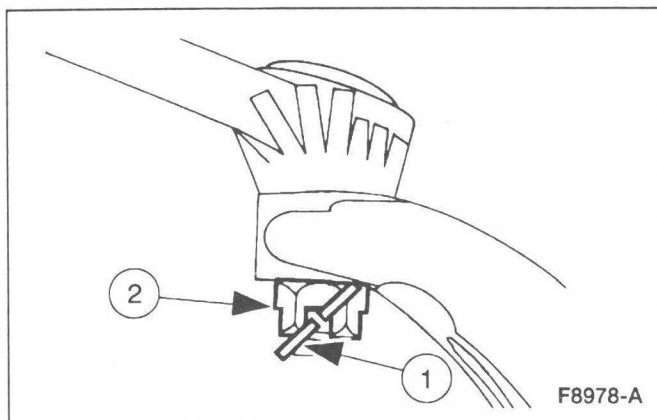
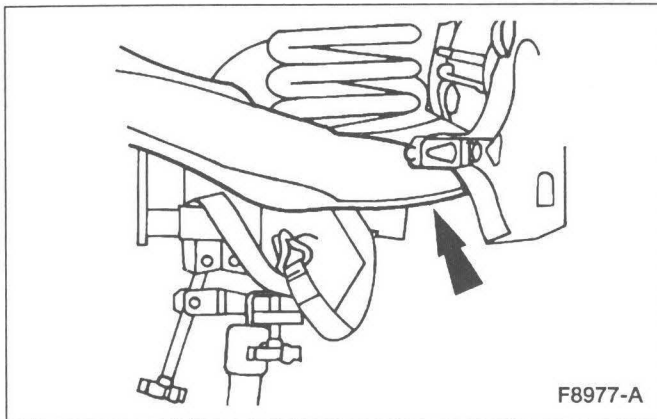

5. Remove the upper ball joint castellated nut.
  - 1 Remove the cotter pin.
  - 2 Remove the nut.

**100% SATISFACTION GUARANTEED**

**BUY IT NOW!**

**Click Here To Order**



## REMOVAL AND INSTALLATION (Continued)

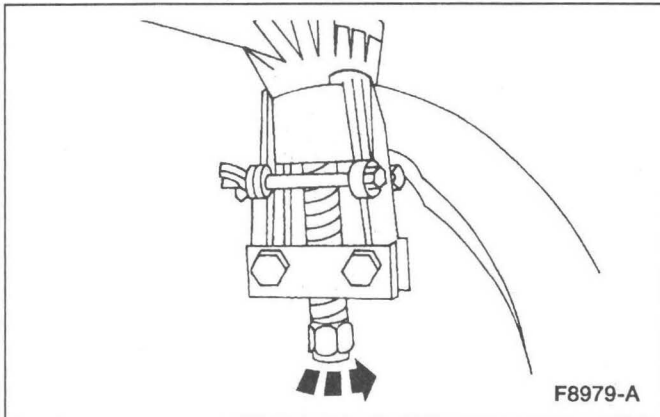

6. Use the Pitman Arm Puller to separate the ball joint from the front wheel spindle (3105).

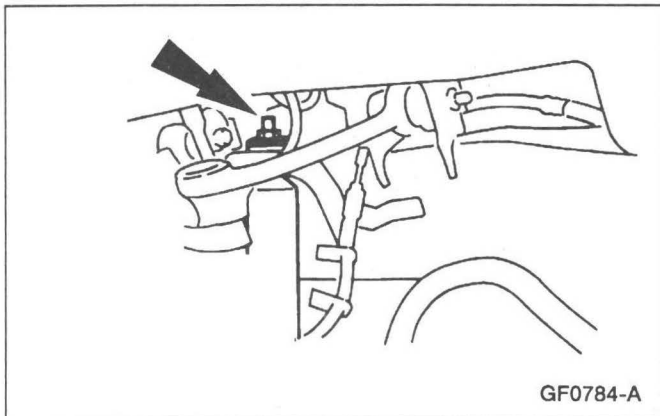

7. Remove the upper shock absorber nut.

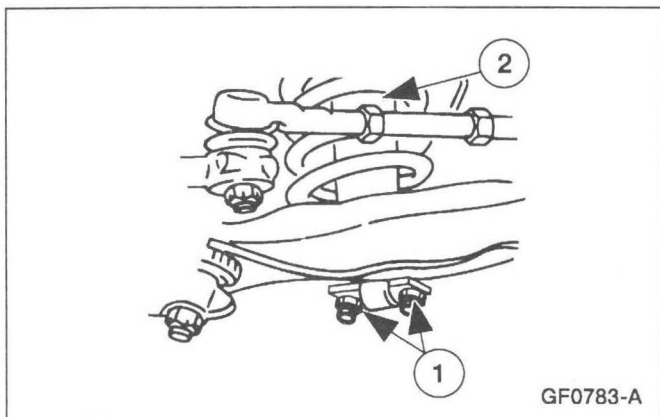

8. Remove the front shock absorber (18124).
  - 1 Remove two shock absorber lower nuts.
  - 2 Remove the front shock absorber.



9. Remove the tie rod castellated nut.
  - 1 Remove the cotter pin.
  - 2 Remove the castellated nut.



**BUY IT NOW!**

**Click Here To Order**



## REMOVAL AND INSTALLATION (Continued)

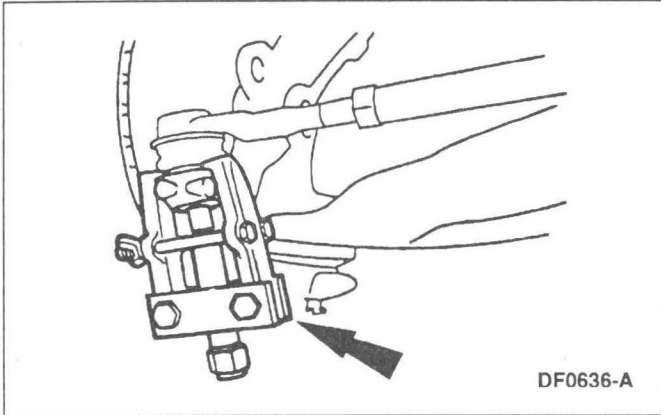

10. Use the Pitman Arm Puller to separate the tie rod end (3A130) from the front wheel spindle.

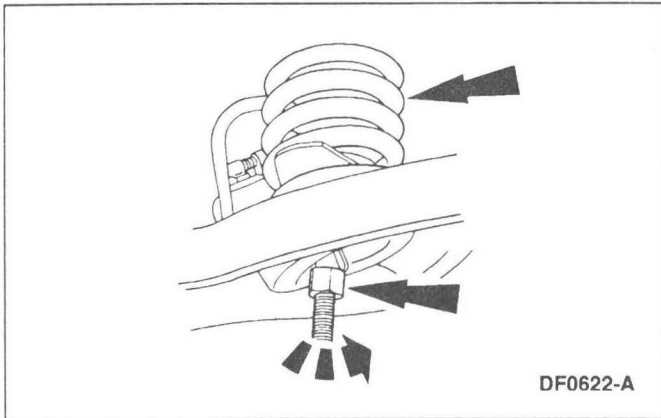

11. Use the Coil Spring Compressor to compress the coil spring.

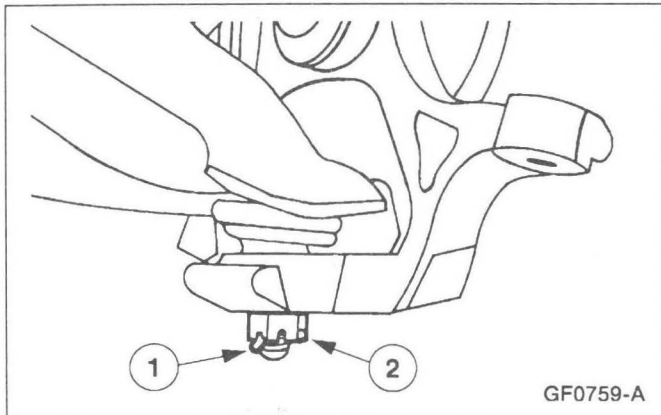

12. Remove lower ball joint castellated nut.
- 1 Remove the cotter pin.
  - 2 Remove the castellated nut.

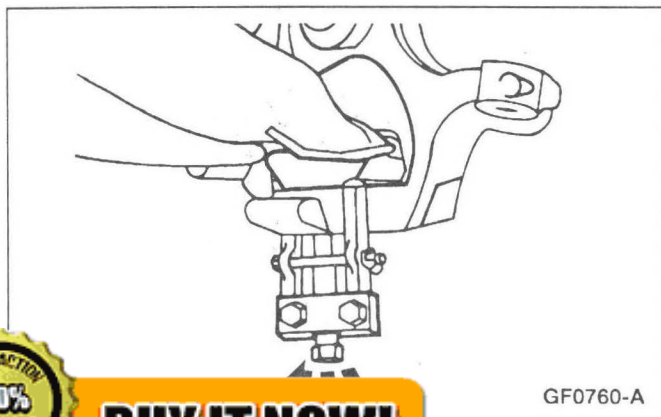

13. Use the Pitman Arm Puller to separate the lower ball joint from the front wheel spindle.

14. Remove the front wheel spindle.

**100% SATISFACTION GUARANTEED**

**BUY IT NOW!**

**Click Here To Order**

## REMOVAL AND INSTALLATION (Continued)

## Installation

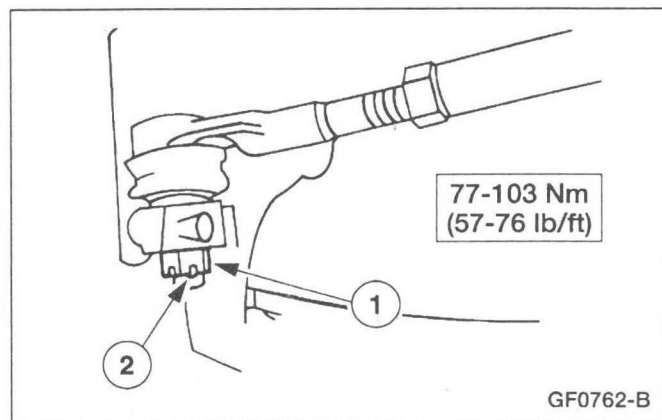
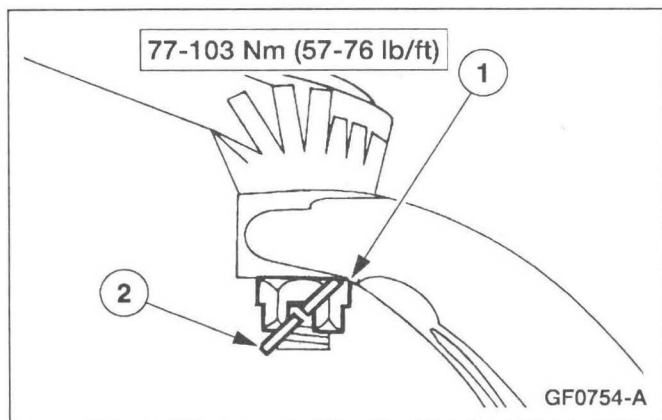
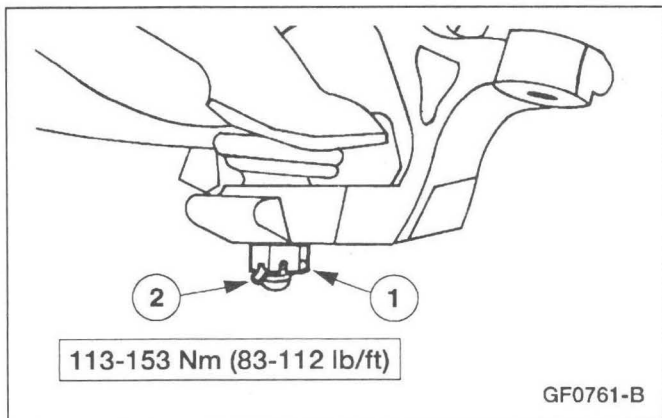

1. Install the lower ball joint castellated nut.
  - 1 Install the castellated nut.
  - 2 Install a new cotter pin.

2. Install the upper ball joint castellated nut.
  - 1 Install the castellated nut.
  - 2 Install a new cotter pin.

3. Remove the Coil Spring Compressor.

4. Install the tie rod castellated nut.
  - 1 Install the nut.
  - 2 Install a new cotter pin.



**BUY IT NOW!**

**Click Here To Order**



## REMOVAL AND INSTALLATION (Continued)

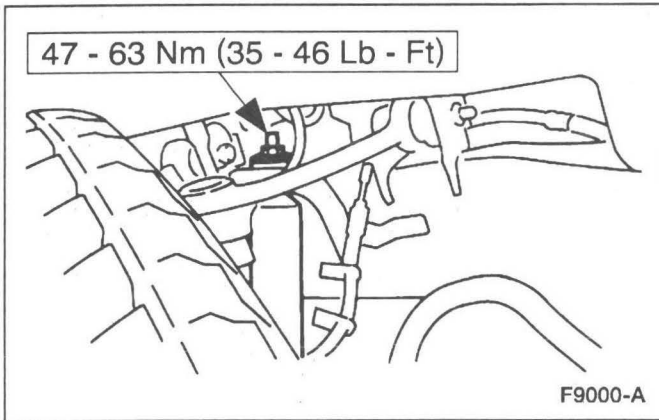
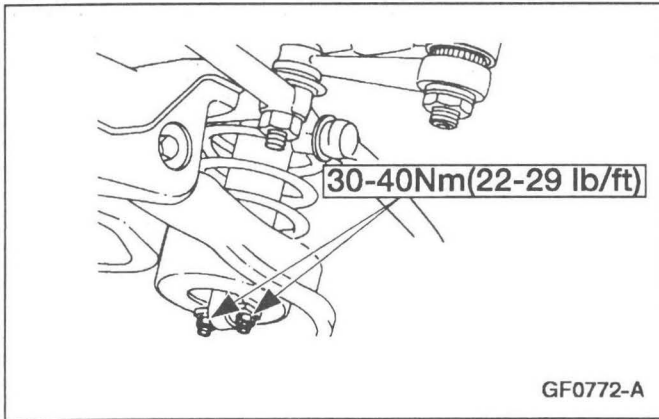

5. Install the front shock absorber and the two shock absorber lower nuts.
6. Install the upper shock absorber nut.
7. Install the brake disc shield; for additional information, refer to Section 206-03.
8. **NOTE:** If equipped with air suspension, reactivate the system by turning on the air suspension switch.  
Install the tire and wheel assembly; for additional information, refer to Section 204-04.
9. Inspect and adjust the front end alignment; for additional information, refer to Section 204-00.

**100% SATISFACTION GUARANTEED**

**BUY IT NOW!**

**Click Here To Order**

## REMOVAL AND INSTALLATION (Continued)

## Spring — Coil

## Special Tool(s)

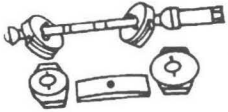
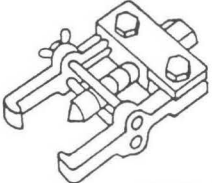
 <p>ST1352-A</p>	<p>Coil Spring Compressor 204-D001 (D78P-5310-A) or Equivalent</p>
 <p>ST1263-A</p>	<p>Pitman Arm Puller 211-003 (T64P-3590-F)</p>

## Removal

1.  **WARNING:** The electrical power to the air suspension system must be shut off prior to hoisting, jacking or towing an air suspension vehicle. This can be accomplished by turning off the air suspension switch located in the RH kick panel area. Failure to do so can result in unexpected inflation or deflation of the air springs, which can result in shifting of the vehicle during these operations.

Raise the vehicle on a hoist; for additional information, refer to Section 100-02.

2. Remove the wheel and tire assembly; for additional information, refer to Section 204-04.
3. Remove the brake disc shield (2K004); for additional information, refer to Section 206-03.
4. Remove the upper shock absorber nut and washer.

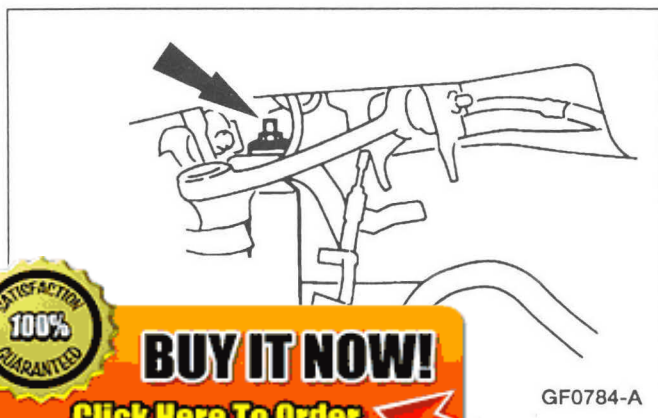

**BUY IT NOW!**

**Click Here To Order**



## REMOVAL AND INSTALLATION (Continued)

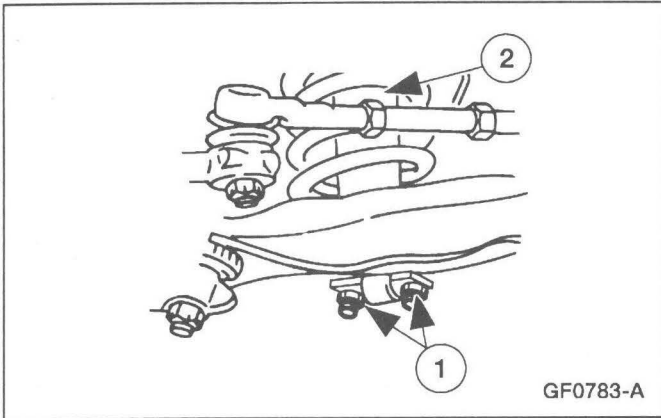

5. Remove the front shock absorber (18124).

- 1 Remove two nuts.
- 2 Remove the shock absorber.

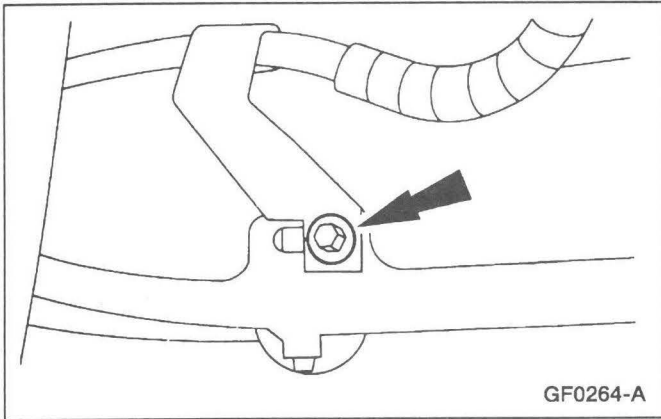

6. Remove the brake hose bracket from the front suspension lower arm (3079).

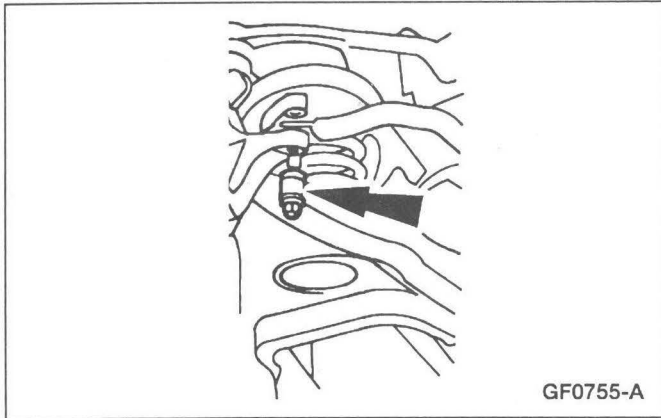

7. Remove the front stabilizer bar link nut.

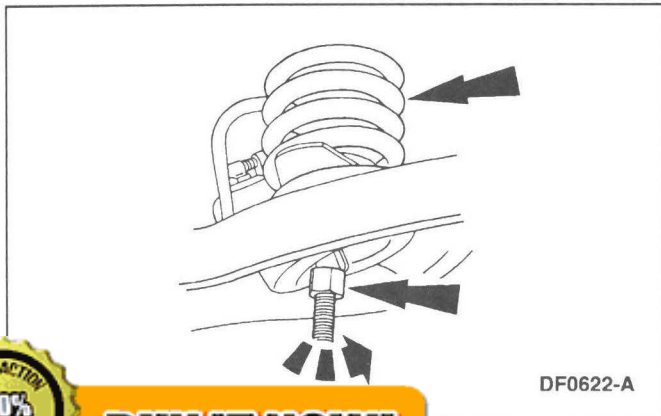

8. Use the Coil Spring Compressor to compress the coil spring.



**BUY IT NOW!**

**Click Here To Order**

PayPal

Discover  
Cards

DISCOVER  
NOWUS

MasterCard

VISA

## REMOVAL AND INSTALLATION (Continued)

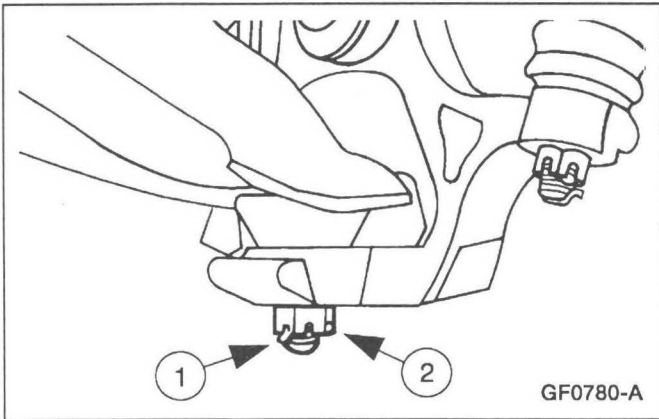

9. Remove the lower ball joint castellated nut.
  - 1 Remove the cotter pin.
  - 2 Remove the castellated nut.

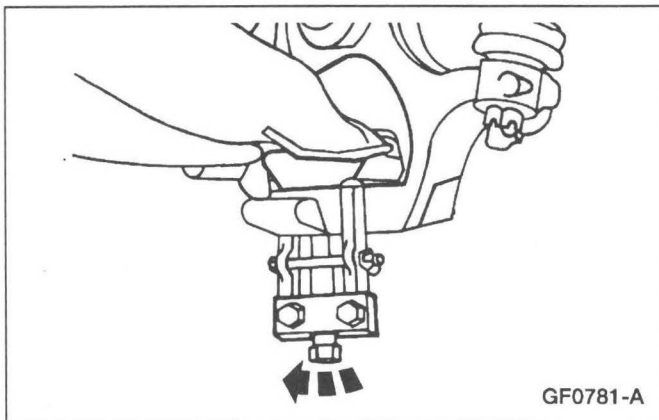

10. Use the Pitman Arm Puller to separate the lower ball joint from the front wheel spindle (3105).

11. Position the front wheel spindle out of the way and remove the coil spring.

## Installation

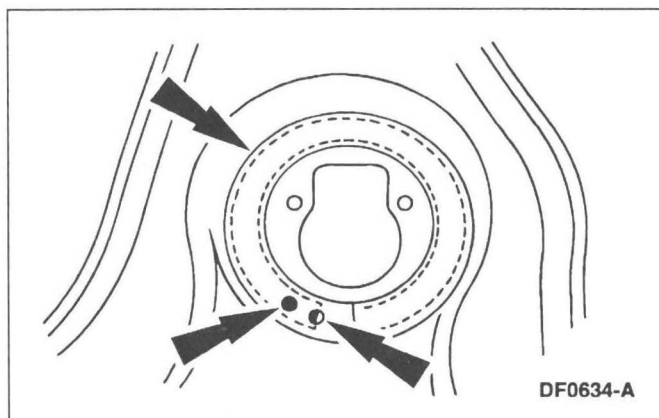

1. **NOTE:** The end of the coil spring must cover the first hole and be visible in the second hole.  
Install the front coil spring (5310) into the front suspension lower arm (3078).



**BUY IT NOW!**

Click Here To Order



## REMOVAL AND INSTALLATION (Continued)

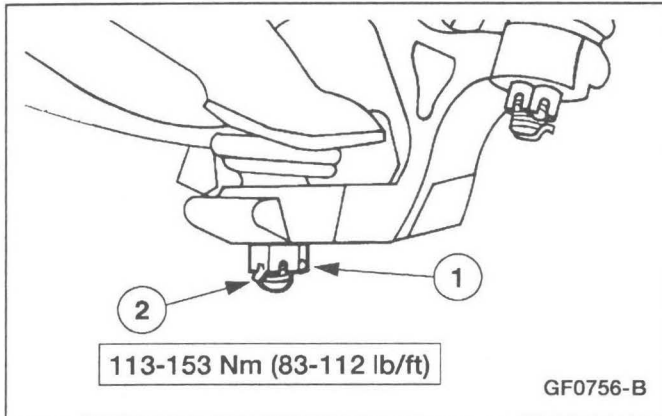

2. Install the lower ball joint.
  - 1 Install the castellated nut.
  - 2 Install a new cotter pin.

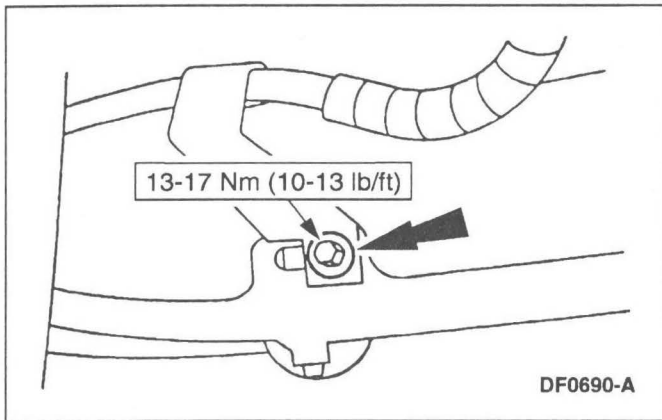

3. Install the brake hose bracket to the front suspension lower arm.

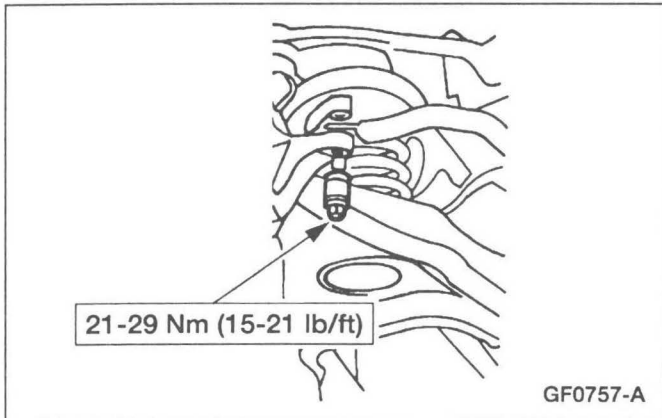

4. Install the front stabilizer bar link nut.



5. Remove the Coil Spring Compressor.
6. Install the front shock absorber and the two shock absorber lower nuts.



**BUY IT NOW!**

**Click Here To Order**



## REMOVAL AND INSTALLATION (Continued)

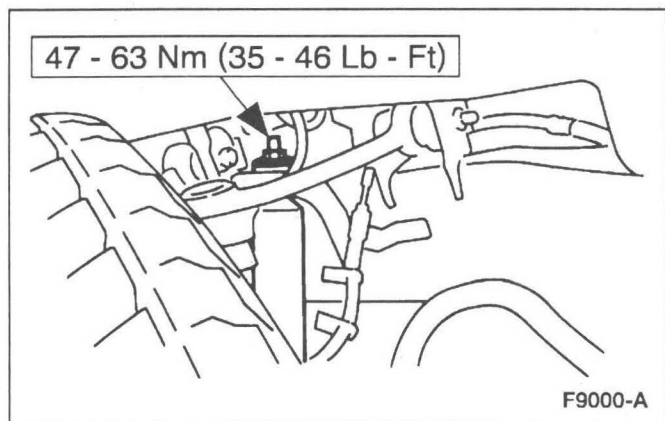

7. Install the upper shock absorber washer and nut.
8. Install the brake disc shield; for additional information, refer to Section 206-03.
9. **NOTE:** If equipped with air suspension, reactivate the system by turning on the air suspension switch.  
Install the tire and wheel assembly; for additional information, refer to Section 204-04.
10. Inspect and adjust the front end alignment; for additional information, refer to Section 204-00.

## SPECIFICATIONS

## Torque Specifications

Description	Nm	Lb-Ft
Brake Hose Bracket to Front Suspension Lower Arm Screw	13-17	10-13
Front Stabilizer Bar Bracket Bolt	26-35	19-26
Front Stabilizer Bar Link Nut	21-29	15-21
Front Suspension Lower Arm Nut	164-200	121-148
Front Suspension Upper Arm Cam Bolts and Nuts	113-153	84-112

(Continued)

## Torque Specifications

Description	Nm	Lb-Ft
Front Suspension Upper Arm Nut	113-153	84-112
Lower Ball Joint Nut	113-153	83-112
Lug Nuts	113-153	83-112
Shock Absorber Lower Nuts	30-40	22-29
Tie Rod Castellated Nut	77-103	57-76
Upper Ball Joint Castellated Nut	77-103	57-76
Upper Shock Absorber Nut	47-63	35-46

**100% SATISFACTION GUARANTEED**

**BUY IT NOW!**

**Click Here To Order**

# SECTION 204-01B Front Suspension — 4x4

VEHICLE APPLICATION: F-150/F-250

CONTENTS	PAGE
<b>DESCRIPTION AND OPERATION</b>	
Front Suspension .....	204-01B-2
<b>DIAGNOSIS AND TESTING</b>	
Front Suspension — 4x4 .....	204-01B-3
<b>REMOVAL AND INSTALLATION</b>	
Arm — Lower .....	204-01B-7
Arm — Upper .....	204-01B-12
Ball Joint .....	204-01B-28
Bar — Stabilizer .....	204-01B-28
Bar — Torsion .....	204-01B-17
Bushing — Control Arm .....	204-01B-28
Knuckle — Front Wheel .....	204-01B-22
Shock Absorber .....	204-01B-28
Wheel Hub .....	204-01B-3
Wheel Studs .....	204-01B-7
<b>GENERAL PROCEDURES</b>	
Ride Height .....	204-01B-29
<b>SPECIFICATIONS</b> .....	204-01B-31

**100% SATISFACTION GUARANTEED**

**BUY IT NOW!**

**Click Here To Order**

PayPal American Express Discover MasterCard VISA

## DESCRIPTION AND OPERATION

### Front Suspension

#### Front Suspension — 4x4 Components

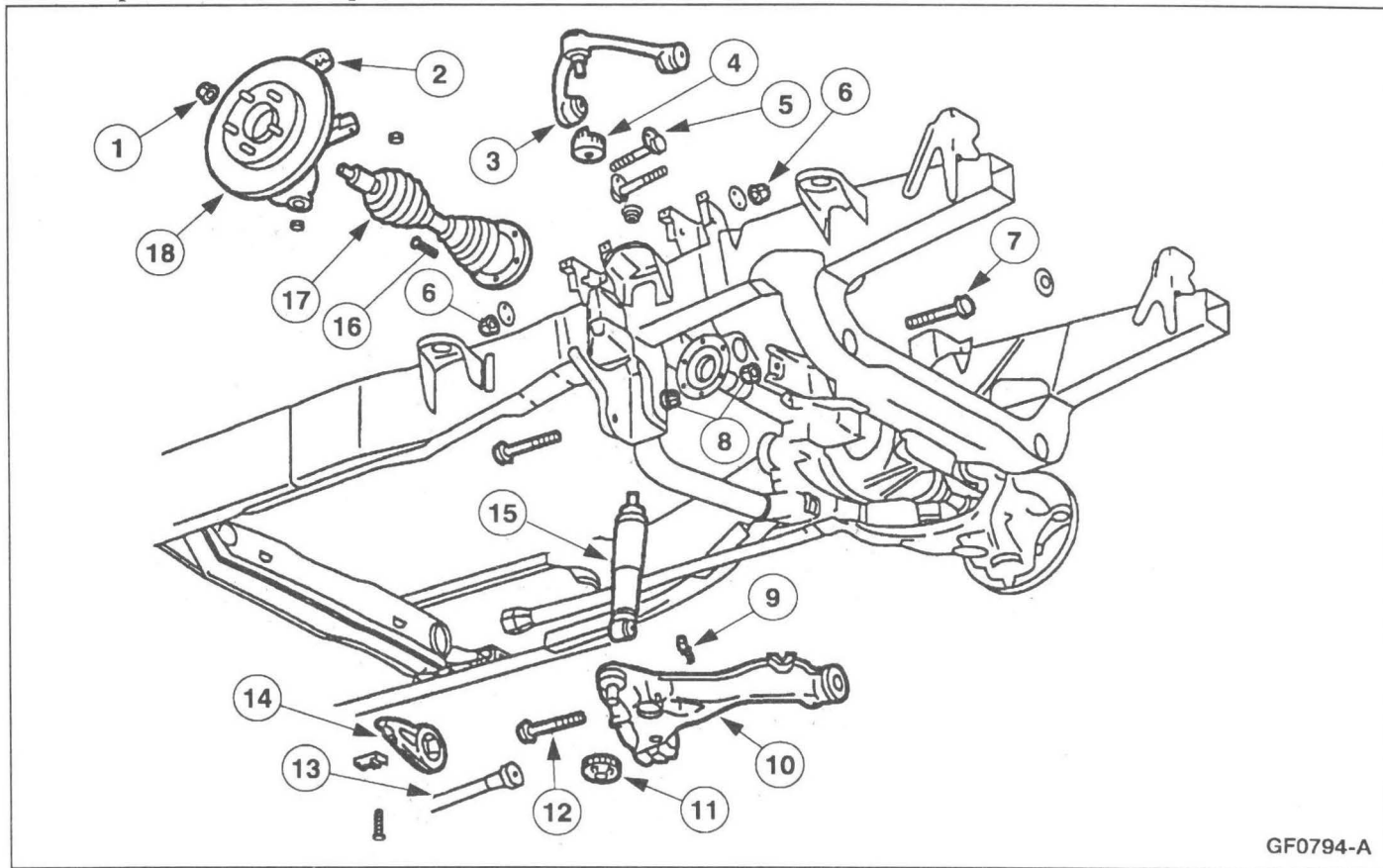

Item	Part Number	Description
1	—	Front Axle Hub Nut (2 Req'd)
2	3K185	Front Wheel Knuckle— (2 Req'd)
3	3082	Front Suspension Upper Arm— (2 Req'd)
4	—	Front Suspension Upper Arm Shield — (2 Req'd)
5	—	Front Suspension Upper Arm Adjusting Cam and Bolts (2 Req'd)
6	—	Front Suspension Upper Arm Nuts
7	—	Front Suspension Lower Arm Bolts
8	—	Front Suspension Lower Arm Nuts

Item	Part Number	Description
9	—	Front Shock Absorber Lower Nut (2 Req'd)
10	3042/3051	Front Suspension Lower Arm (2 Req'd)
11	—	Front Suspension Lower Arm Shield (2 Req'd)
12	—	Front Shock Absorber Lower Bolt (2 Req'd)
13	—	Torsion Bar (2 Req'd)
14	—	Torsion Bar Adjuster
15	18124	Front Shock Absorber— (2 Req'd)
16	—	Front Wheel Driveshaft and Joint Bolt
17	—	Front Wheel Driveshaft and Joint
18	1125	Brake Disc



**BUY IT NOW!**

**Click Here To Order**



## DIAGNOSIS AND TESTING



### Front Suspension — 4x4

Refer to Section 204-00.

## REMOVAL AND INSTALLATION

### Wheel Hub

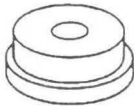
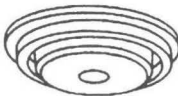
#### Special Tool(s)

 <p>ST1359-A</p>	<p>Bearing Cup Replacer 205-147 (T80T-4000-P)</p>
 <p>ST1153-A</p>	<p>Seal Replacer 205-361 (T96T-1175-A)</p>
 <p>ST1360-A</p>	<p>Threaded Drawbar 204-029 (T77F-1176-A)</p>

### Removal

1.  **WARNING:** The electrical power to the air suspension system must be shut off prior to hoisting, jacking or towing an air suspension vehicle. This can be accomplished by turning off the air suspension switch located in the RH kick panel area. Failure to do so can result in unexpected inflation or deflation of the air springs, which can result in shifting of the vehicle during these operations.

Turn off the air suspension switch, if so equipped.

2. Remove the wheel and tire assembly; for additional information, refer to Section 204-04.

**100% SATISFACTORY GUARANTEED**

**BUY IT NOW!**

**Click Here To Order**



## REMOVAL AND INSTALLATION (Continued)

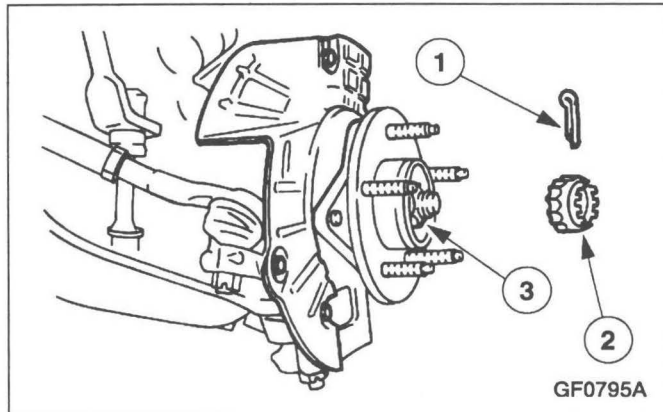

3. Remove the brake disc (1125) ; for additional information, refer to Section 206-03.

4. Remove the front wheel hub nut.

1 Remove the cotter pin.

2 Remove the retainer.

3 Remove the front wheel hub nut.

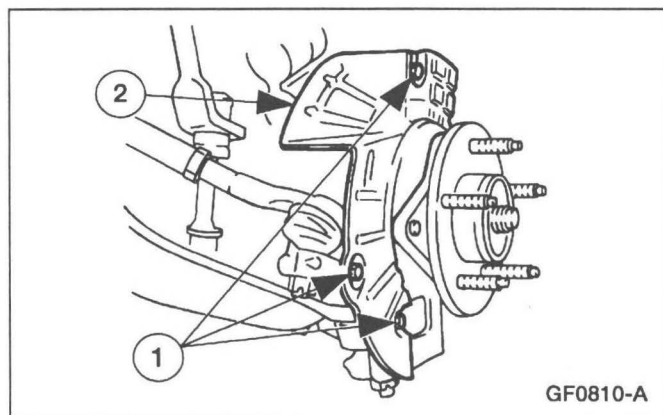

5. If equipped with 4-wheel anti-lock brake system (4WABS), remove the brake disc shield (2K004).

1 Remove the bolts.

2 Remove the brake disc shield.

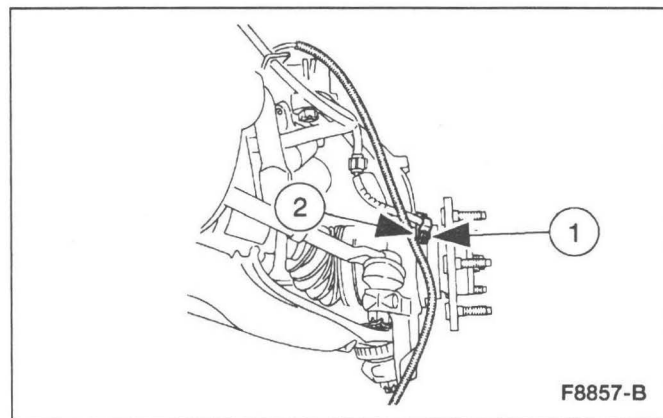

6. If equipped with 4WABS, remove the front brake anti-lock sensor (2C204).

1 Remove the bolt.

2 Remove the front brake anti-lock sensor.



**BUY IT NOW!**

Click Here To Order



## REMOVAL AND INSTALLATION (Continued)

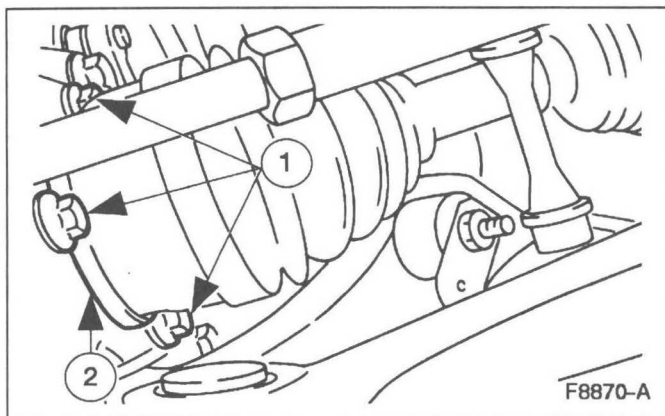

7. **CAUTION:** Do not overextend CV joint and boots when removing the hub and bearing assembly.

**NOTE:** The CV joint is a slip fit into the wheel hub and bearing. A puller will not normally be required.

Remove the wheel hub (1104).

- 1 Remove the bolts.
- 2 Push the CV joint inboard. Remove the wheel hub.

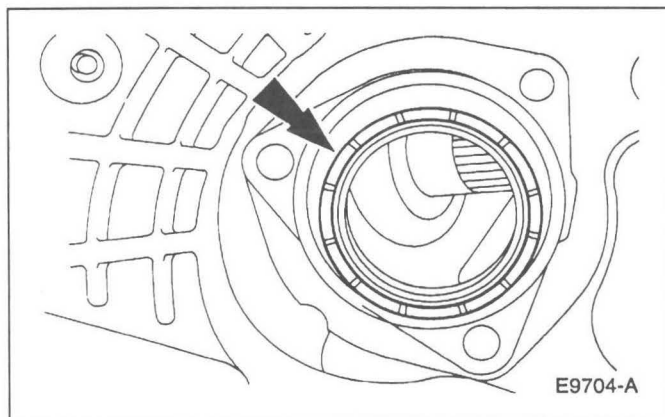

8. Remove the seal.

## Installation

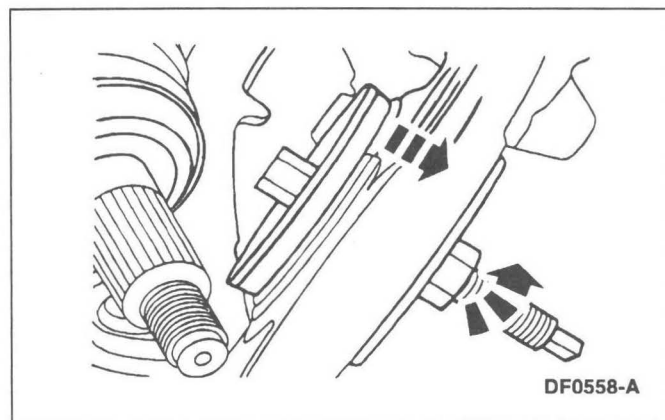

1. Install the seal.
  - Using the Seal Replacer, Threaded Drawbar and the Bearing Cup Replacer, install the seal.

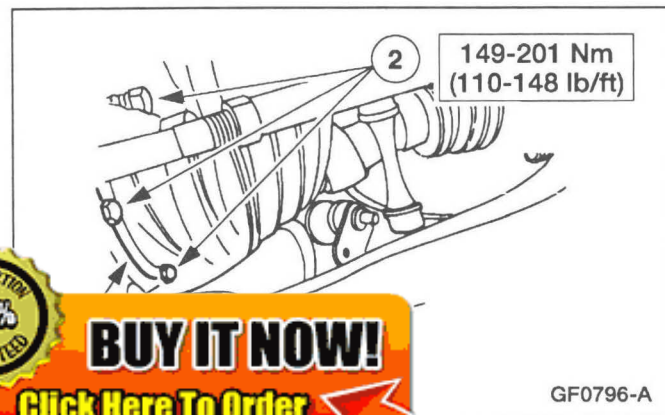

2. Install the wheel hub.
  - 1 Position the wheel hub on the front wheel driveshaft and joint (3B436) and into the front wheel knuckle (3K185).
  - 2 Install the bolts.



**BUY IT NOW!**

**Click Here To Order**





**TECHNICAL  
SUPPORT OPERATIONS**

Ford Customer Service Division



**BUY IT NOW!**  
**Click Here To Order** 



LITHO IN U.S.A.  
PG - 2216  
REPRINTED 1,200 2-99



FCS-12272-99-1

1 • 9 • 9 • 9

# F-150 F-250

VOLUME II



**WORKSHOP MANUAL**



**BUY IT NOW!**

**Click Here To Order**



PayPal

Discover  
Cards

DISCOVER  
REVUS

MasterCard

VISA



**Official  
Licensed  
Product**

License #84356800

# TABLE OF CONTENTS

## INTRODUCTION

### GROUP 3 POWERTRAIN

03 Engine

07 Automatic Transmission

08 Manual Transmission, Clutch, and Transfer Case

09 Exhaust System

10 Fuel System

## INDEX

All rights reserved. Reproduction by any means, electronic or mechanical, including photocopying, recording, or by any information storage and retrieval system or translation in whole or part is not authorized without the prior written authorization from Ford Motor Company.



**BUY IT NOW!**

**Click Here To Order**

PayPal

MasterCard

Discover  
NewUS

MasterCard

VISA

# INTRODUCTION

**NOTE:** The descriptions and specifications contained in this manual were in effect at the time this manual was approved for printing. Ford Motor Company reserves the right to discontinue models at any time, or change specifications or design without notice and without incurring any obligation.

## IMPORTANT SAFETY NOTICE

Appropriate service methods and procedures are essential for the safe, reliable operation of all motor vehicles as well as the personal safety of the individual doing the work. This manual provides general directions for performing service with tested, effective techniques. Following them will help assure reliability.

There are numerous variations in procedure, techniques, tools and parts for servicing vehicles, as well as in the skill of the individual doing the work. This manual cannot possibly anticipate all such variations and provide advice or cautions as to each. Accordingly, anyone who departs from the instructions provided in this manual must first establish that he compromises neither his personal safety nor the vehicle integrity by his choice of methods, tools or parts.

## NOTES, CAUTIONS, AND WARNINGS

As you read through the procedures, you will come across **NOTES**, **CAUTIONS**, and **WARNINGS**. Each one is there for a specific purpose. **NOTES** give you added information that will help you to perform a particular procedure. **CAUTIONS** are given to prevent you from making an error that could damage the vehicle. **WARNINGS** remind you to be especially careful in those areas where carelessness can cause you personal injury. The following list contains some general **WARNINGS** that you should follow when you work on a vehicle.

- **ALWAYS WEAR SAFETY GLASSES FOR EYE PROTECTION.**
- **USE SAFETY STANDS WHENEVER A PROCEDURE REQUIRES YOU TO BE UNDER THE VEHICLE.**
- **MAKE SURE THAT THE IGNITION SWITCH IS ALWAYS IN THE OFF POSITION, UNLESS OTHERWISE REQUIRED BY THE PROCEDURE.**
- **SET THE PARKING BRAKE WHEN WORKING ON THE VEHICLE. IF YOU HAVE AN AUTOMATIC TRANSMISSION, SET IN PARK UNLESS INSTRUCTED OTHERWISE FOR A SPECIFIC OPERATION. IF YOU HAVE A MANUAL TRANSMISSION, IT SHOULD BE IN REVERSE (ENGINE OFF) OR NEUTRAL (ENGINE ON) UNLESS INSTRUCTED OTHERWISE FOR A SPECIFIC OPERATION. PLACE WOOD BLOCKS (4" X 4" OR LARGER) AGAINST THE FRONT AND REAR SURFACES OF THE TIRES TO HELP PREVENT THE VEHICLE FROM MOVING.**
- **OPERATE THE ENGINE ONLY IN A WELL-VENTILATED AREA TO AVOID THE DANGER OF CARBON MONOXIDE POISONING.**
- **KEEP YOURSELF AND YOUR CLOTHING AWAY FROM MOVING PARTS WHEN THE ENGINE IS RUNNING, ESPECIALLY THE DRIVE BELTS.**
- **TO PREVENT SERIOUS BURNS, AVOID CONTACT WITH HOT METAL PARTS SUCH AS THE RADIATOR, EXHAUST MANIFOLD, TAIL PIPE, THREE-WAY CATALYTIC CONVERTER AND MUFFLER.**
- **DO NOT SMOKE WHILE WORKING ON A VEHICLE.**

**TO AVOID INJURY, ALWAYS REMOVE RINGS, WATCHES, LOOSE HANGING JEWELRY AND LOOSE CLOTHING BEFORE WORKING ON A VEHICLE.**

**WHEN WORKING UNDER THE HOOD, KEEP HANDS AND OTHER OBJECTS CLEAR OF**



**BUY IT NOW!**

**Click Here To Order**



## GROUP

# POWERTRAIN 3

SECTION TITLE	PAGE
Engine System — General Information .....	303-00-1
Engine — 4.2L .....	303-01A-1
Engine — 4.6L and 5.4L .....	303-01B-1
Engine Cooling .....	303-03-1
Fuel Charging and Controls — 4.2L .....	303-04A-1
Fuel Charging and Controls — 4.6L .....	303-04B-1
Fuel Charging and Controls — 5.4L (2V) .....	303-04C-1
Fuel Charging and Controls — Natural Gas Vehicle .....	303-04D-1
Accessory Drive .....	303-05-1
Starting System .....	303-06-1
Engine Ignition — 4.2L .....	303-07A-1
Engine Ignition — 4.6L .....	303-07B-1
Engine Ignition — 5.4L .....	303-07C-1
Engine Emission Control .....	303-08-1
Intake Air Distribution and Filtering .....	303-12-1
Evaporative Emissions .....	303-13-1
Electronic Engine Controls .....	303-14-1
Automatic Transmission — 4R100 .....	307-01A-1
Automatic Transmission — 4R70W .....	307-01B-1
Transaxle/Transmission Cooling .....	307-02-1
Automatic Transaxle/Transmission External Controls .....	307-05-1
Manual Transaxle/Transmission and Clutch — General Information .....	308-00-1
Clutch .....	308-01-1
Clutch Controls .....	308-02-1
Manual Transaxle/Transmission .....	308-03-1
Transfer Case — General Information .....	308-07A-1
Transfer Case .....	308-07B-1
Exhaust System — General Information .....	309-00-1
Fuel System — General Information — Gasoline and Diesel .....	310-00A-1
Fuel System — General Information — Natural Gas .....	310-00B-1
Fuel Tank and Lines—Gasoline and Diesel .....	310-01A-1
Fuel Tank and Lines — Natural Gas .....	310-01B-1
Acceleration Control .....	310-02-1
Vehicle Speed Control .....	310-03-1

## SECTION 303-00 Engine System — General Information

VEHICLE APPLICATION: F-150/F-250



**BUY IT NOW!**

**Click Here To Order**

PayPal

MasterCard

Discover

MasterCard

VISA

CONTENTS	PAGE
<b>DESCRIPTION AND OPERATION</b>	
Engine .....	303-00-4
<b>DIAGNOSIS AND TESTING</b>	
Engine .....	303-00-4
Component Tests .....	303-00-8
Compression Test—Compression Gauge Check .....	303-00-9
Cylinder Leakage Detection .....	303-00-10
Excessive Engine Oil Consumption .....	303-00-13
Inspection and Verification .....	303-00-4
Intake Manifold Vacuum Test .....	303-00-12
Oil Consumption Test .....	303-00-10
Symptom Chart .....	303-00-5
Valve Train Analysis—Engine Off—Valve Cover Removed .....	303-00-14
Valve Train Analysis—Engine Running .....	303-00-14
<b>GENERAL PROCEDURES</b>	
Bearing —Inspection .....	303-00-51
Camshaft —End Play, OHC Engines .....	303-00-22
Camshaft —Lobe Lift .....	303-00-23
Camshaft —Lobe Surface .....	303-00-23
Camshaft —Push Rod Engines .....	303-00-21
Camshaft —Runout .....	303-00-23
Camshaft Journal —Clearance, Plastigage Method .....	303-00-20
Camshaft Journal —Clearance, Push Rod Engines, Micrometer Method .....	303-00-20
Camshaft Journal —Diameter .....	303-00-19
Connecting Rod —Bearing Journal Clearance .....	303-00-35
Connecting Rod —Bend .....	303-00-34
Connecting Rod —Bushing Diameter .....	303-00-34
Connecting Rod —Cleaning .....	303-00-33
Connecting Rod —Large End Bore .....	303-00-33
Connecting Rod —Piston Pin Side Clearance .....	303-00-35
Connecting Rod —Twist .....	303-00-34
Crankshaft —Connecting Rod Journal Taper, Out of Round .....	303-00-27
Crankshaft —End Play .....	303-00-26
Crankshaft —Runout .....	303-00-26
Crankshaft Main Bearing Journal —Clearance .....	303-00-25
Crankshaft Main Bearing Journal —Diameter .....	303-00-24
Crankshaft Main Bearing Journal —Taper .....	303-00-24
Cylinder Block —Core Plug Replacement .....	303-00-46
Cylinder Block —Distortion .....	303-00-45
Cylinder Bore —Cleaning .....	303-00-45
Cylinder Bore —Honing .....	303-00-43
Cylinder Bore —Out-of-Round .....	303-00-28
Cylinder Bore —Taper .....	303-00-27
Cylinder Head —Distortion .....	303-00-43
Exhaust Manifold —Inspection .....	303-00-50
.....	303-00-42
.....	303-00-30
.....	303-00-28



**BUY IT NOW!**

**Click Here To Order**



**CONTENTS**

**PAGE**

Piston —Pin Diameter.....303-00-33

Piston —Pin to Bore Diameter.....303-00-29

Piston —Ring End Gap .....303-00-31

Piston —Ring-to-Groove Clearance .....303-00-32

Piston —Selection .....303-00-30

Piston —to Cylinder Bore Clearance.....303-00-30

Push Rods —Cleaning.....303-00-18

Push Rods —Inspection .....303-00-18

Rocker Arms —Cleaning .....303-00-17

Rocker Arms —Inspection .....303-00-18

Roller Follower —Inspection .....303-00-36

Spark Plug —Thread Repair .....303-00-47

Sprockets .....303-00-17

Valve —Guide Inner Diameter.....303-00-39

Valve —Guide Reaming.....303-00-39

Valve —Inspection .....303-00-39

Valve —Seat Inspection .....303-00-41

Valve —Seat Runout.....303-00-42

Valve —Seat Width .....303-00-42

Valve —Spring Free Length .....303-00-40

Valve —Spring Installed Length .....303-00-40

Valve —Spring Squareness .....303-00-40

Valve —Spring Strength.....303-00-41

Valve —Stem Diameter.....303-00-37

Valve —Stem to Valve Guide Clearance .....303-00-38

Valve Tappet —Inspection .....303-00-36

Valve Tappet —Leakdown Test, Hydraulic .....303-00-37

**SPECIFICATIONS .....303-00-51**



**BUY IT NOW!**

**Click Here To Order**



## DESCRIPTION AND OPERATION

### Engine

**NOTE:** This section contains information, steps and procedures that may not be specific to your engine.

This section covers general procedures and diagnosis and testing of the engine system, except for exhaust emission control devices, which are covered in the Powertrain Control/Emissions Diagnosis Manual <sup>1</sup>.

The engines incorporate the following features:

- a closed positive crankcase ventilation (PCV) system. For additional information, refer to Section 303-08.

- an exhaust emission control system. For additional information, refer to Section 303-08.
- an evaporative emission control system. For additional information, refer to Section 303-13.

The engine, fuel system, ignition system, emissions system and exhaust system all affect exhaust emission levels and must be maintained according to the maintenance schedule. Refer to the Owner's Guide.





Correct engine identification is required to order parts; refer to the appropriate engine section.

For complete vehicle and engine identification codes, refer to Section 100-01.



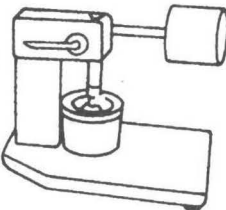

## DIAGNOSIS AND TESTING

### Engine

#### Special Tool(s)

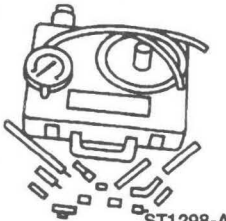
	Commercially Available Leakdown Tester
 <p>ST1299-A</p>	Compression Tester 134-R0212 or equivalent
 <p>ST1272-A</p>	Cup Shaped Adapter 303-007 (TOOL-6565-AB) or equivalent
	Dial Indicator with Bracketry 100-002 (TOOL-4201-C) or equivalent

#### Special Tool(s)

 <p>ST1298-A</p>	Engine Cylinder Leak Detection/Air Pressurization Kit 014-00708 or equivalent
 <p>ST1296-A</p>	Engine Oil Pressure Gauge 303-088 (T73L-6600-A)
 <p>ST1300-A</p>	12 Volt Master UV Diagnostic Inspection Kit 164-R0756 or equivalent (Leak Detector)
 <p>ST1297-A</p>	Vacuum/Pressure Tester 164-R0253 or equivalent

#### Inspection and Verification

1. Verify the customer concern by operating the engine to duplicate the condition.

**100% SATISFACTION GUARANTEED**

**BUY IT NOW!**

**Click Here To Order**



**DIAGNOSIS AND TESTING (Continued)**

2. Visually inspect for obvious signs of mechanical damage. Refer to the following chart.

**Visual Inspection Chart**

Mechanical
<ul style="list-style-type: none"> <li>• Engine coolant leaks</li> <li>• Engine oil leaks</li> <li>• Fuel leaks</li> <li>• Damaged or severely worn parts</li> <li>• Loose mounting bolts, studs and nuts</li> </ul>

3. If the inspection reveals obvious concerns that can be readily identified, repair as required.

4. If the concerns remain after the inspection, determine the symptoms and go to the symptom chart.

**Symptom Chart**

**SYMPTOM CHART**

Condition	Possible Source	Action
<ul style="list-style-type: none"> <li>• Difficult Starting</li> </ul>	<ul style="list-style-type: none"> <li>• Damaged ignition system.</li> <li>• Damaged fuel system.</li> <li>• Damaged starting system.</li> <li>• Damaged charger system/battery.</li> <li>• Burnt valve.</li> <li>• Worn piston.</li> <li>• Worn piston rings.</li> <li>• Worn cylinder.</li> <li>• Damaged head gasket.</li> </ul>	<ul style="list-style-type: none"> <li>• Refer to the appropriate section in Group 303 for the procedure. REFER to the Powertrain Control/Emissions Diagnosis Manual <sup>2</sup>.</li> <li>• Refer to the appropriate section in Group 303 for the procedure. REFER to the Powertrain Control/Emissions Diagnosis Manual <sup>2</sup>.</li> <li>• REFER to the appropriate starter section in Group 303. REFER to the Powertrain Control/Emissions Diagnosis Manual <sup>2</sup>.</li> <li>• REFER to Section 414-00.</li> <li>• REPLACE valve.</li> <li>• REPLACE piston and piston head.</li> <li>• REPLACE piston ring.</li> <li>• REPAIR or REPLACE cylinder block.</li> <li>• REPLACE head gasket.</li> </ul>

**100% SATISFACTION GUARANTEED**

**BUY IT NOW!**

**Click Here To Order**

PayPal American Express Discover MasterCard VISA

**DIAGNOSIS AND TESTING (Continued)****SYMPTOM CHART (Continued)**

Condition	Possible Source	Action
<ul style="list-style-type: none"> <li>Poor Idling</li> </ul>	<ul style="list-style-type: none"> <li>Vacuum leaks.</li> <li>Malfunctioning or damaged ignition system.</li> <li>Malfunctioning or damaged fuel system.</li> <li>Damaged valve tappet or lash adjuster.</li> <li>Damaged valve tappet guide or lash adjuster.</li> <li>Improper valve-to-valve seat contact.</li> <li>Damaged head gasket.</li> </ul>	<ul style="list-style-type: none"> <li>Refer to the appropriate section in Group 303 for the procedure. REFER to the Powertrain Control/Emissions Diagnosis Manual <sup>3</sup>.</li> <li>Refer to the appropriate section in Group 303 for the procedure. REFER to the Powertrain Control/Emissions Diagnosis Manual <sup>3</sup>.</li> <li>Refer to the appropriate section in Group 303 for the procedure. REFER to the Powertrain Control/Emissions Diagnosis Manual <sup>3</sup>.</li> <li>REPLACE valve tappet or lash adjuster.</li> <li>REPLACE valve tappet guide or valve tappet.</li> <li>REPAIR or REPLACE valve or valve seat.</li> <li>REPLACE head gasket.</li> </ul>
<ul style="list-style-type: none"> <li>Abnormal Combustion</li> </ul>	<ul style="list-style-type: none"> <li>Malfunctioning or damaged fuel system.</li> <li>Malfunctioning or damaged ignition system.</li> <li>Damaged valve tappet or lash adjuster.</li> <li>Damaged valve tappet guide or valve tappet.</li> <li>Burnt or sticking valve.</li> <li>Weak or broken valve spring.</li> <li>Carbon accumulation in combustion chamber.</li> </ul>	<ul style="list-style-type: none"> <li>Refer to the appropriate section in Group 303 for the procedure. REFER to the Powertrain Control/Emissions Diagnosis Manual <sup>3</sup>.</li> <li>Refer to the appropriate section in Group 303 for the procedure. REFER to the Powertrain Control/Emissions Diagnosis Manual <sup>3</sup>.</li> <li>REPLACE valve tappet or lash adjuster.</li> <li>REPLACE valve tappet guide or valve tappet.</li> <li>REPAIR or REPLACE valve.</li> <li>REPLACE valve spring.</li> <li>ELIMINATE carbon buildup.</li> </ul>
<ul style="list-style-type: none"> <li>Excessive Oil Consumption</li> </ul>	<ul style="list-style-type: none"> <li>Leaking oil.</li> <li>Malfunctioning PCV system.</li> <li>Worn valve stem seal.</li> <li>Worn valve stem or valve guide.</li> <li>Sticking piston rings.</li> <li>Worn piston ring groove.</li> <li>Worn piston or cylinder.</li> </ul>	<ul style="list-style-type: none"> <li>REPAIR oil leakage.</li> <li>REPAIR or REPLACE the necessary components.</li> <li>REPLACE valve stem seal.</li> <li>REPLACE valve stem and valve guide.</li> <li>REPAIR or REPLACE piston rings.</li> <li>REPLACE piston and piston pin.</li> <li>REPAIR or REPLACE piston or cylinder block.</li> </ul>



**BUY IT NOW!**

**Click Here To Order**



**DIAGNOSIS AND TESTING (Continued)****SYMPTOM CHART (Continued)**

Condition	Possible Source	Action
<ul style="list-style-type: none"> <li>• Engine Noise</li> </ul>	<ul style="list-style-type: none"> <li>• Leaking exhaust system.</li> <li>• Improper drive belt tension.</li> <li>• Malfunctioning generator bearing.</li> <li>• Malfunctioning water pump bearing.</li> <li>• Malfunctioning or damaged cooling system.</li> <li>• Malfunctioning or damaged fuel system.</li> <li>• Loose timing chain/belt (6268).</li> <li>• Damaged timing chain tensioner (6L266).</li> <li>• Excessive main bearing clearance.</li> <li>• Seized or heat damaged crankshaft main bearing.</li> <li>• Excessive crankshaft end play.</li> <li>• Excessive connecting rod bearing clearance.</li> <li>• Heat damaged connecting rod bearing (6211).</li> <li>• Damaged connecting rod bushing (6207).</li> <li>• Worn cylinder.</li> <li>• Worn piston (6108) or piston pin (6135).</li> <li>• Damaged piston rings.</li> <li>• Bent connecting rod.</li> <li>• Malfunctioning valve tappet (6500) or lash adjuster.</li> <li>• Excessive valve tappet or lash adjuster clearance.</li> <li>• Broken valve spring (6513).</li> <li>• Excessive valve guide clearance.</li> </ul>	<ul style="list-style-type: none"> <li>• REPAIR exhaust leakage.</li> <li>• REFER to Section 303-05.</li> <li>• Refer to the appropriate section in Group 414 for the procedure.</li> <li>• REFER to Section 303-03.</li> <li>• REFER to Section 303-03.</li> <li>• Refer to the appropriate section in Group 303 for the procedure. REFER to the Powertrain Control/Emissions Diagnosis Manual <sup>4</sup>.</li> <li>• ADJUST or REPLACE timing chain/belt.</li> <li>• REPLACE timing chain tensioner.</li> <li>• ADJUST clearance or REPLACE crankshaft main bearing (6333).</li> <li>• REPLACE crankshaft main bearing.</li> <li>• REPLACE thrust bearing or crankshaft (6303).</li> <li>• REPLACE connecting rod bearing or connecting rod (6200).</li> <li>• REPLACE connecting rod bearing.</li> <li>• REPLACE connecting rod bushing.</li> <li>• REPAIR or REPLACE cylinder block (6010).</li> <li>• REPLACE piston or piston pin.</li> <li>• REPLACE piston rings.</li> <li>• REPLACE connecting rod.</li> <li>• REPLACE valve tappet or lash adjuster.</li> <li>• ADJUST clearance or REPLACE valve tappet guide or valve tappet.</li> <li>• REPLACE valve spring.</li> <li>• REPAIR clearance or REPLACE valve guide (6510) and stem.</li> </ul>



**BUY IT NOW!**  
Click Here To Order



**DIAGNOSIS AND TESTING (Continued)****SYMPTOM CHART (Continued)**

Condition	Possible Source	Action
<ul style="list-style-type: none"> <li>Insufficient Power</li> </ul>	<ul style="list-style-type: none"> <li>Malfunctioning or damaged ignition system.</li> <li>Malfunctioning or damaged fuel system.</li> <li>Damaged or plugged exhaust system.</li> <li>Incorrect tire size.</li> <li>Dragging brakes.</li> <li>Slipping transmission.</li> <li>Malfunctioning valve tappet or lash adjuster.</li> <li>Damaged valve tappet guide or valve tappet.</li> <li>Compression leakage at valve seat.</li> <li>Seized valve stem.</li> <li>Weak or broken valve spring.</li> <li>Worn or damaged cam.</li> <li>Damaged head gasket (6051).</li> <li>Cracked or distorted cylinder head.</li> <li>Damaged, worn or sticking piston ring(s).</li> <li>Worn or damaged piston.</li> </ul>	<ul style="list-style-type: none"> <li>Refer to the appropriate section in Group 303 for the procedure. REFER to the Powertrain Control/Emissions Diagnosis Manual <sup>5</sup>.</li> <li>Refer to the appropriate section in Group 303 for the procedure. REFER to the Powertrain Control/Emissions Diagnosis Manual <sup>5</sup>.</li> <li>INSPECT exhaust system.</li> <li>REFER to Section 204-04.</li> <li>REFER to Section 206-00.</li> <li>Refer to the appropriate section in Group 307 for the procedure.</li> <li>REPLACE valve tappet or lash adjuster.</li> <li>REPLACE valve tappet guide or valve tappet.</li> <li>REPAIR or REPLACE valve, valve seat or cylinder head (6049).</li> <li>REPLACE valve stem.</li> <li>REPLACE valve spring.</li> <li>REPLACE camshaft.</li> <li>REPLACE head gasket.</li> <li>REPLACE cylinder head.</li> <li>REPAIR or REPLACE piston ring(s).</li> <li>REPLACE piston and piston pin.</li> </ul>

**Component Tests****Engine Oil Leaks**

**NOTE:** When diagnosing engine oil leaks, the source and location of the leak must be positively identified prior to service.

Prior to performing this procedure, clean the cylinder block, cylinder heads, valve covers, oil pan and flywheel with a suitable solvent to remove all traces of oil.

**Engine Oil Leaks—Fluorescent Oil Additive Method**

Use the 12 Volt Master UV Diagnostic Inspection Kit to perform the following procedure for oil leak diagnosis.

- Add Oil Dye 164-R3705 meeting Ford specification ESE-M99C103-B1 or equivalent. Use a minimum 14.8 ml (0.5 ounce) to a maximum 29.6 ml (1 ounce) of fluorescent additive to all engines. If the oil is not premixed, fluorescent additive must first be added to crankcase.
- Run the engine for 15 minutes. Stop the engine and inspect all seal and gasket areas for leaks using the 12 Volt Master UV Diagnostic Inspection Kit. A clear bright yellow or orange area will identify the leak. For extremely small leaks, several hours may be required for the leak to appear.



**BUY IT NOW!**

**Click Here To Order**



able solvent to remove

## DIAGNOSIS AND TESTING (Continued)

### Leakage Points—Underhood

Examine the following areas for oil leakage:

- valve cover gaskets
- intake manifold gaskets
- cylinder head gaskets
- oil bypass filter
- oil filter adapter
- engine front cover
- oil filter adapter and filter body
- oil level indicator tube connection
- oil pressure sensor

### Leakage Points—Under Engine—With Vehicle on Hoist

- oil pan gaskets (6710)
- oil pan sealer
- oil pan rear seal (6723)
- engine front cover gasket
- crankshaft front seal (6700)
- crankshaft rear oil seal (6701)
- crankshaft main bearing cap side bolts
- oil filter adapter and filter body
- oil cooler, if equipped

### Leakage Points—With Transmission and Flywheel Removed

- crankshaft rear oil seal
- rear main bearing cap parting line
- rear main bearing cap and seals

- flywheel mounting bolt holes (with flywheel (6375) installed)
- camshaft rear bearing covers (6266) or pipe plugs at the end of oil passages

Oil leaks at crimped seams in sheet metal parts and cracks in cast or stamped parts can be detected when using the dye method.

### Compression Test—Compression Gauge Check

1. Make sure the oil in the crankcase is of the correct viscosity and at the proper level and that the battery (10655) is properly charged. Operate the vehicle until the engine is at normal operating temperature. Turn the ignition switch to the OFF position, then remove all the spark plugs (12405).
2. Set the throttle plates in the wide-open position.
3. Install a compression gauge such as the Compression Tester in the No. 1 cylinder.
4. Install an auxiliary starter switch in the starting circuit. With the ignition switch in the OFF position, and using the auxiliary starter switch, crank the engine a minimum of five compression strokes and record the highest reading. Note the approximate number of compression strokes required to obtain the highest reading.
5. Repeat the test on each cylinder, cranking the engine approximately the same number of compression strokes.

### Compression Test—Test Results

The indicated compression pressures are considered within specification if the lowest reading cylinder is within 75 percent of the highest reading. Refer to the Compression Pressure Limit Chart.

Compression Pressure Limit Chart

Maximum Pressure	Minimum Pressure	Maximum Pressure	Minimum Pressure	Maximum Pressure	Minimum Pressure	Maximum Pressure	Minimum Pressure
924 kPa (134 psi)	696 kPa (101 psi)	1131 kPa (164 psi)	848 kPa (123 psi)	1338 kPa (194 psi)	1000 kPa (146 psi)	1544 kPa (224 psi)	1158 kPa (168 psi)
938 kPa (136 psi)	703 kPa (102 psi)	1145 kPa (166 psi)	855 kPa (124 psi)	1351 kPa (196 psi)	1014 kPa (147 psi)	1558 kPa (226 psi)	1165 kPa (169 psi)
952 kPa (138 psi)	717 kPa (104 psi)	1158 kPa (168 psi)	869 kPa (126 psi)	1365 kPa (198 psi)	1020 kPa (148 psi)	1572 kPa (228 psi)	1179 kPa (171 psi)
965 kPa (140 psi)	724 kPa (106 psi)	1172 kPa (170 psi)	876 kPa (127 psi)	1379 kPa (200 psi)	1034 kPa (150 psi)	1586 kPa (230 psi)	1186 kPa (172 psi)
979 kPa (142 psi)	731 kPa (107 psi)	1185 kPa (172 psi)	889 kPa (129 psi)	1393 kPa (202 psi)	1041 kPa (151 psi)	1600 kPa (232 psi)	1200 kPa (174 psi)



**BUY IT NOW!**

**Click Here To Order**



**DIAGNOSIS AND TESTING (Continued)****Compression Pressure Limit Chart**

Maximum Pressure	Minimum Pressure	Maximum Pressure	Minimum Pressure	Maximum Pressure	Minimum Pressure	Maximum Pressure	Minimum Pressure
933 kPa (144 psi)	745 kPa (109 psi)	1200 kPa (174 psi)	903 kPa (131 psi)	1407 kPa (204 psi)	1055 kPa (153 psi)	1055 kPa (153 psi)	1207 kPa (175 psi)
1007 kPa (146 psi)	758 kPa (110 psi)	1214 kPa (176 psi)	910 kPa (132 psi)	1420 kPa (206 psi)	1062 kPa (154 psi)	1627 kPa (154 psi)	1220 kPa (177 psi)
1020 kPa (148 psi)	765 kPa (111 psi)	1227 kPa (178 psi)	917 kPa (133 psi)	1434 kPa (208 psi)	1075 kPa (156 psi)	1641 kPa (238 psi)	1227 kPa (178 psi)
1034 kPa (150 psi)	779 kPa (113 psi)	1241 kPa (180 psi)	931 kPa (135 psi)	1448 kPa (210 psi)	1083 kPa (157 psi)	1655 kPa (240 psi)	1241 kPa (180 psi)
1048 kPa (152 psi)	786 kPa (114 psi)	1255 kPa (182 psi)	936 kPa (136 psi)	1462 kPa (212 psi)	1089 kPa (158 psi)	1669 kPa (242 psi)	1248 kPa (181 psi)
1062 kPa (154 psi)	793 kPa (115 psi)	1269 kPa (184 psi)	952 kPa (138 psi)	1476 kPa (214 psi)	1103 kPa (160 psi)	1682 kPa (244 psi)	1262 kPa (183 psi)
1076 kPa (156 psi)	807 kPa (117 psi)	1282 kPa (186 psi)	965 kPa (140 psi)	1489 kPa (216 psi)	1117 kPa (162 psi)	1696 kPa (246 psi)	1269 kPa (184 psi)
1089 kPa (158 psi)	814 kPa (118 psi)	1296 kPa (188 psi)	972 kPa (141 psi)	1503 kPa (218 psi)	1124 kPa (163 psi)	1710 kPa (248 psi)	1202 kPa (186 psi)
1103 kPa (160 psi)	827 kPa (120 psi)	1310 kPa (190 psi)	979 kPa (142 psi)	1517 kPa (220 psi)	1138 kPa (165 psi)	1724 kPa (250 psi)	1289 kPa (187 psi)
1110 kPa (161 psi)	834 kPa (121 psi)	1324 kPa (192 psi)	993 kPa (144 psi)	1631 kPa (222 psi)	1145 kPa (166 psi)	—	—

If one or more cylinders reads low, squirt approximately one tablespoon of Super Premium SAE 5W30 Motor Oil, XO-5W30-QSP meeting Ford specification WSS-M2C153-G on top of the pistons in the low-reading cylinders. Repeat the compression pressure check on these cylinders.

**Compression Test—Interpreting Compression Readings**

1. If compression improves considerably, piston rings are faulty.
2. If compression does not improve, valves are sticking or seating improperly.
3. If two adjacent cylinders indicate low compression pressures and squirting oil on each piston does not increase compression, the head gasket may be leaking between cylinders. Engine oil or coolant in cylinders could result from this condition.

Use the Compression Pressure Limit Chart when checking cylinder compression so that the lowest reading is within 75 percent of the highest reading.

The leakage detector is inserted in the spark plug hole, the piston is brought up to dead center on the compression stroke, and compressed air is admitted.

Once the combustion chamber is pressurized, a special gauge included in the kit will read the percentage of leakage. Leakage exceeding 20 percent is excessive.

While the air pressure is retained in the cylinder, listen for the hiss of escaping air. A leak at the intake valve (6507) will be heard in the throttle body (9E926). A leak at the exhaust valve (6505) can be heard at the tail pipe. Leakage past the piston rings will be audible at the positive crankcase ventilation (PCV) connection. If air is passing through a blown head gasket to an adjacent cylinder, the noise will be evident at the spark plug hole of the cylinder into which the air is leaking. Cracks in the cylinder block or gasket leakage into the cooling system may be detected by a stream of bubbles in the radiator (8005).

**Oil Consumption Test**

The following diagnostic procedure is used to determine the source of excessive internal oil consumption.

**Cylinder Leakage Detection**

Reading, use of the Air Pressurization Kit exact cause.

**BUY IT NOW!**  
Click Here To Order

PayPal Discover MasterCard VISA

**DIAGNOSIS AND TESTING (Continued)**

1. **NOTE:** Oil use is normally greater during the first 16,100 km (10,000 miles) of service. As mileage increases, oil use generally decreases. Vehicles in normal service should get at least 1,450 km per liter (900 miles per quart) after 16,100 km (10,000 miles) of service. High speed driving, towing, high ambient temperature and other factors may result in greater oil use.  
Define excessive oil consumption, such as the number of miles driven per liter (quart) of oil used. Also determine customer's driving habits, such as sustained high speed operation, towing, extended idle and other considerations.
2. Verify that the engine has no external oil leak as described under Engine Oil Leaks in the Diagnosis and Testing portion of this section.
3. Verify that the engine has the correct oil level dipstick (6750).
4. Verify that the engine is not being run in an overfilled condition. Check the oil level at least five minutes after a hot shutdown with the vehicle parked on a level surface. In no case should the level be above MAX or the letter F in FULL. If significantly overfilled, perform steps 6a through 6d.
5. Verify the spark plugs are not oil saturated. If the spark plugs are oil saturated and compression is good it can be assumed the valve seals or valve guides are at fault.
6. Perform an oil consumption test:
  - a. Drain the engine oil, remove the oil bypass filter (6714) and refill with one liter (quart) less than the recommended amount.
  - b. Run the engine for three minutes (10 minutes if cold), and allow the oil to drain back for at least five minutes with the vehicle on a level surface.
  - c. Remove oil level dipstick and wipe clean. (Do not wipe with anything contaminated with silicone compounds.) Reinstall the oil level dipstick, being sure to seat it firmly in the oil level indicator tube (6754). Remove the oil level dipstick and draw a mark on the back (unmarked) surface at the indicated oil level. This level should be about the same as the MIN or ADD mark on the face of the oil
  - d. Add one liter (quart) of oil. Restart the engine and allow to idle for at least two minutes. Shut off the engine and allow the oil to drain back for at least five minutes. Mark the oil level dipstick, using the procedure above.
  - e. Record the vehicle mileage.
  - f. Instruct the customer to drive the vehicle as usual and perform the following:
    - Check the oil level regularly at intervals of 160 to 240 km (100-150 miles).
    - Return to the service point when the oil level drops below the lower (MIN or ADD) mark on the oil level dipstick.
    - Add only full liters (quarts) of the same oil in an emergency. Note the mileage at which the oil is added.
  - g. Check the oil level under the same conditions and at the same location as in Steps 5c and 5d.
    - Measure the distance from the oil level to the UPPER mark on the oil level dipstick and record.
    - Measure the distance between the two scribe marks and record.
    - Divide the first measurement by the second.
    - Divide the distance driven during the oil test by the result. This quantity is the approximate oil consumption rate in kilometers per liter or in miles per quart.
  - h. If the oil consumption rate is unacceptable, go to Step 7.
7. Check the positive crankcase ventilation (PCV) system. Make sure the system is not plugged.
8. Check for plugged oil drain-back holes in the cylinder heads and cylinder block.
9. If the condition still exists after performing the above steps, go to Step 10.
10. Perform a cylinder compression test or perform a cylinder leak detection test with Engine Cylinder Leak Detection/Air Pressurization Kit. This can help determine the source of oil consumption such as valves, piston rings or other areas.



**BUY IT NOW!**

**Click Here To Order**



## DIAGNOSIS AND TESTING (Continued)

11. **NOTE:** After determining if worn parts should be replaced, make sure correct replacement parts are used.

Check valve guides for excessive guide clearance. REPLACE all valve stem seals (6571) after verifying valve guide clearance.

12. Worn or damaged internal engine components can cause excessive oil consumption. Small deposits of oil on the tips of spark plugs can be a clue to internal oil consumption. If internal oil consumption still persists, proceed as follows:
- Remove the engine from the vehicle and place it on an engine work stand. Remove the intake manifolds (9424), cylinder heads, oil pan (6675) and oil pump (6600).
  - Check piston ring clearance, ring gap and ring orientation. Repair as required.
  - Check for excessive bearing clearance. Repair as required.
13. Repeat the oil consumption test (Step 6) to confirm the oil consumption concern has been resolved.

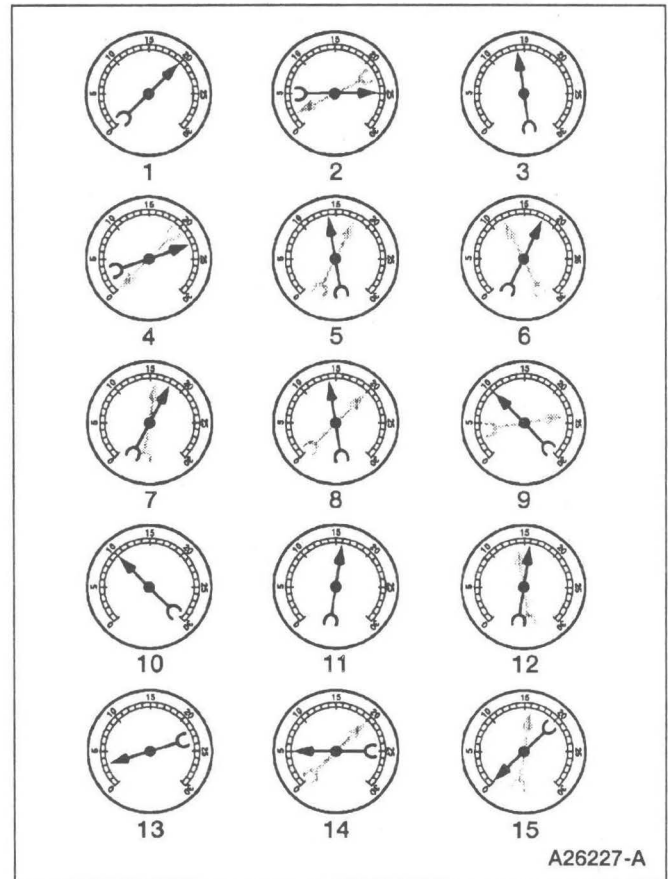

A26227-A

### Intake Manifold Vacuum Test

Bring the engine to normal operating temperature. Connect the Vacuum/Pressure Tester to the intake manifold. Run the engine at the specified idle speed.

The vacuum gauge should read between 51-74 kPa (15-22 in-Hg) depending upon the engine condition and the altitude at which the test is performed. Subtract 4.0193 kPa (1 in-Hg) from the specified reading for every 304.8 m (1,000 feet) of elevation above sea level.

The reading should be steady. If necessary, adjust the gauge damper control (where used) if the needle is fluttering rapidly. Adjust the damper until the needle moves easily without excessive flutter.

### Intake Manifold Vacuum Test—Interpreting Vacuum Gauge Readings

A careful study of the vacuum gauge reading while the engine is idling will help pinpoint trouble areas. Always conduct other appropriate tests before arriving at a final diagnostic decision. Vacuum gauge readings, although helpful, must be interpreted carefully.

Most vacuum gauges have a normal band indicated on

the readings. Some are indicated further.

- NORMAL READING:** Needle between 51-74 kPa (15-22 in-Hg) and holding steady.
- NORMAL READING DURING RAPID ACCELERATION AND DECELERATION:** When the engine is rapidly accelerated (dotted needle), the needle will drop to a low reading (not to zero). When the throttle is suddenly released, the needle will snap back up to a higher than normal figure.
- NORMAL FOR HIGH-LIFT CAMSHAFT WITH LARGE OVERLAP:** The needle will register as low as 51 kPa (15 in-Hg) but will be relatively steady. Some oscillation is normal.
- WORN RINGS OR DILUTED OIL:** When the engine is accelerated (dotted needle), the needle drops to 0 kPa (0 in-Hg). Upon deceleration, the needle runs slightly above 74 kPa (22 in-Hg).
- STICKING VALVES:** When the needle (dotted) remains steady at a normal vacuum but occasionally flicks (sharp, fast movement) down and back about 13 kPa (4 in-Hg), one or more valves may be sticking.



**BUY IT NOW!**

[Click Here To Order](#)



**DIAGNOSIS AND TESTING (Continued)**

6. **BURNED OR WARPED VALVES:** A regular, evenly-spaced, downscale flicking of the needle indicates one or more burned or warped valves. Insufficient hydraulic lash adjuster or hydraulic lash adjuster (HLA) clearance will also cause this reaction.
7. **POOR VALVE SEATING:** A small but regular downscale flicking can mean one or more valves are not seating.
8. **WORN VALVE GUIDES:** When the needle oscillates over about a 13 kPa (4 in-Hg) range at idle speed, the valve guides could be worn. As engine speed increases, the needle will become steady if guides are responsible.
9. **WEAK VALVE SPRINGS:** When the needle oscillation becomes more violent as engine rpm is increased, weak valve springs are indicated. The reading at idle could be relatively steady.
10. **LATE VALVE TIMING:** A steady but low reading could be caused by late valve timing.
11. **IGNITION TIMING RETARDING:** Retarded ignition timing will produce a steady but somewhat low reading.
12. **INSUFFICIENT SPARK PLUG GAP:** When spark plugs are gapped too close, a regular, small pulsation of the needle can occur.
13. **INTAKE LEAK:** A low, steady reading can be caused by an intake manifold or throttle body gasket leak.
14. **BLOWN HEAD GASKET:** A regular drop of fair magnitude can be caused by a blown head gasket or warped cylinder head-to-cylinder block surface.
15. **RESTRICTED EXHAUST SYSTEM:** When the engine is first started and is idled, the reading may be normal, but as the engine rpm is increased, the back pressure caused by a clogged muffler (5230), kinked tail pipe or other concerns will cause the needle to slowly drop to 0 kPa (0 in-Hg). The needle then may slowly rise. Excessive exhaust clogging will cause the needle to drop to a low point even if the engine is only idling.
16. When vacuum leaks are indicated, search out and correct the cause. Excess air leaking into the system will upset the fuel mixture and cause concerns such as rough idle, missing on

If the leak exists in  
power brake booster  
in correctly.

**Excessive Engine Oil Consumption**

The amount of oil an engine uses will vary with the way the vehicle is driven in addition to normal engine-to-engine variation. This is especially true during the first 16,100 km (10,000 miles) when a new engine is being broken in or until certain internal engine components become conditioned. Vehicles used in heavy-duty operation may use more oil. The following are examples of heavy-duty operation:

- trailer towing applications
- severe loading applications
- sustained high speed operation

Engines need oil to lubricate the following internal components:

- cylinder block cylinder walls
- pistons and piston, pin and rings (6102)
- intake and exhaust valve stems
- intake and exhaust valve guides
- all internal engine components

When the pistons move downward, a thin film of oil is left on the cylinder walls. As the vehicle is operated, some oil is also drawn into the combustion chambers past the intake and exhaust valve stem seals and burned.

The following is a partial list of conditions that can affect oil consumption rates:

- engine duty cycle
- operator driving habits
- ambient temperature
- quality and viscosity of the oil

Operation under varying conditions can frequently be misleading. A vehicle that has been run for several thousand miles on short trips or in below-freezing ambient temperatures may have consumed a “normal” amount of oil. However, when checking the engine oil level, it may measure up to the FULL or MAX on the oil level dipstick due to dilution (condensation and fuel) in the engine crankcase. The vehicle might then be driven at high speeds on the highway where the condensation and fuel boil off. The next time the engine oil is checked, it may appear that a liter (quart) of oil was used in about 160 km (100 miles). This perceived 160 km (100 miles) per liter (quart) oil consumption rate causes customer concern even though the actual overall oil consumption rate is about 2400 km (1500 miles) per liter (quart).



**BUY IT NOW!**

**Click Here To Order**



## DIAGNOSIS AND TESTING (Continued)

Make sure the selected engine oil meets the current recommended API performance category with SAE viscosity grade as shown in the vehicle Owner's Guide. It is also important that the engine oil is changed at the intervals specified. Refer to the Vehicle Owner's Guide.

### Oil Pressure Test

1. Disconnect and remove the oil pressure sensor (9278) from the engine.
2. Connect the Engine Oil Pressure Gauge to the oil pressure sender oil galley port.
3. Run the engine until normal operating temperature is reached.
4. Run the engine at the specified rpm and record the gauge reading.
5. The oil pressure should be within specifications; refer to the specification chart in the appropriate engine section.
6. If the pressure is not within specification, check the following possible sources:
  - insufficient oil
  - oil leakage
  - worn or damaged oil pump
  - oil pump screen cover and tube (6622)
  - excessive main bearing clearance
  - excessive connecting rod bearing clearance

### Valve Train Analysis—Engine Off—Valve Cover Removed

Check for damaged or severely worn parts and correct assembly. Make sure correct parts are used with the static engine analysis as follows.

### Valve Train Analysis—Engine Off, Rocker Arm

- Check for loose mounting bolts, studs and nuts.
- Check for plugged oil feed in the rocker arms (6564) or cylinder head.

### Valve Train Analysis—Engine Off, Camshaft Roller Followers and Hydraulic Lash Adjusters, Overhead Camshaft

- Check for loose mounting bolts on camshaft carriers.

Check for plugged oil feed in the camshaft roller followers and hydraulic lash adjusters in the cylinder heads.

### Valve Train Analysis—Engine Off, Camshaft—Engines

- Check for broken or damaged parts.

### Valve Train Analysis—Engine Off, Push Rods

- Check for bent push rods (6565) and restricted oil passage.

### Valve Train Analysis—Valve Springs

- Check for broken or damaged parts.

### Valve Train Analysis—Engine Off, Valve Spring Retainer and Valve Spring Retainer Keys

- Check for proper seating of the valve spring retainer key (6518) on the valve stem and in valve spring retainer (6514).
- Check for proper seating on the valve stem.

### Valve Train Analysis—Engine Off, Valves and Cylinder Head

- Check for plugged oil drain back holes.
- Check for worn or damaged valve tips.
- Check for missing or damaged guide-mounted valve stem seal.
- Check collapsed valve tappet gap.
- Check installed valve spring height.
- Check for missing or worn valve spring seats.
- Check for plugged oil metering orifice in cylinder head oil reservoir (if equipped).

Static checks (engine off) are to be made on the engine prior to the dynamic procedure.

### Valve Train Analysis—Engine Running

- Start the engine and, while idling, check for proper operation of all parts. Check the following:

**100% SATISFACTION GUARANTEED**

**BUY IT NOW!**

**Click Here To Order**



## DIAGNOSIS AND TESTING (Continued)

### Valve Train Analysis—Engine Running, Positive Rotator and Valve Spring Retainer Keys

- Check for proper operation of positive rotator.

### Valve Train Analysis—Engine Running, Valves and Cylinder Head

- Check for plugged oil drain back holes.
- Check for missing or damaged valve stem seals or guide mounted valve stem seals.
- Check for a plugged oil metering orifice in the cylinder head oil reservoir (4.6L engine only).

If insufficient oiling is suspected, check oil passages for blockage, then accelerate the engine to 1200 rpm with the transmission in NEUTRAL and the engine at normal operating temperature. Oil should spurt from the rocker arm oil holes such that valve tips and camshaft roller followers are well oiled. With the valve covers (6582) off, some oil splash may overshoot camshaft roller followers.

### Valve Train Analysis—Engine Running, Camshaft Lobe Lift—OHC Engines

Check the lift of each camshaft lobe in consecutive order and make a note of the readings.

1. Remove the valve covers.
2. Remove the spark plugs.
3. Install the Dial Indicator with Bracketry so the rounded tip of indicator is on top of the camshaft lobe and on the same plane as the valve tappet.
4. Rotate the crankshaft using a breaker bar and socket attached to the crankshaft pulley retainer bolt. Rotate the crankshaft until the base circle of the camshaft lobe is reached.

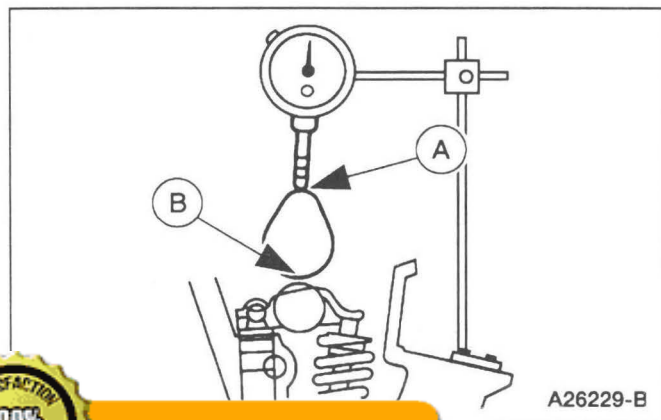

5. Zero the dial indicator. Continue to rotate the crankshaft until the (A) high-lift point of the camshaft lobe is in the fully-raised position (highest indicator reading).
6. To check the accuracy of the original indicator reading, continue to rotate crankshaft until the (B) base circle is reached. The indicator reading should be zero. If zero reading is not obtained, repeat Steps 1 through 6.
7. **NOTE:** If the lift on any lobe is below specified service limits, the camshaft roller followers operating on that camshaft (6250) must be replaced.

Remove the Dial Indicator with Bracketry.

8. Install the spark plugs.
9. Install the valve covers.

### Valve Train Analysis—Engine Running, Camshaft Lobe Lift—Push Rod Engine

Check the lift of each lobe in consecutive order and make a note of the readings.

1. Remove valve covers.
2. Remove rocker arm seat bolts, rocker arm seat (6A528) and rocker arms.

#### Typical Engine With Push Rods

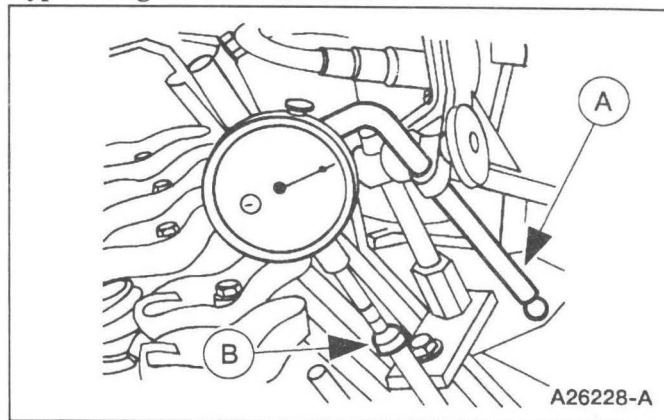

3. Make sure valve tappet is seated against camshaft (6250). Install (A) Dial Indicator with Bracketry so the ball socket adapter of the indicator is on top of the valve tappet or (B) Cup Shaped Adapter is on top of push rod and in same plane as valve tappet push rod movement.
4. Remove spark plugs.



**BUY IT NOW!**

[Click Here To Order](#)



## DIAGNOSIS AND TESTING (Continued)

5. Connect an auxiliary starter switch in the starting circuit. Crank engine with ignition switch in OFF position. Bump crankshaft over until valve tappet is on base circle of camshaft lobe. At this point, valve tappet will be in its lowest position. If checking during engine assembly, turn crankshaft using a socket or ratchet.
6. Zero the dial indicator. Continue to rotate crankshaft slowly until valve tappet is in fully-raised position (highest indicator reading).
7. **NOTE:** If lift on any lobe is below specified service limits, camshaft and valve tappet must be replaced.  
Compare total lift recorded on dial indicator with specifications.
8. To check the accuracy of the original dial indicator reading, continue to rotate the crankshaft until indicator reads zero.
9. Remove the dial indicator, adapter and auxiliary starter switch.
10.  **CAUTION: After installing rocker arms, do not rotate crankshaft until valve tappets have had sufficient time to bleed down. To do otherwise may cause serious valve damage. Manually bleeding-down valve tappets will reduce waiting time.**  
Install rocker arm seats, rocker arms and rocker arm seat bolts.
11. Install valve covers.
12. Install spark plugs.

### Valve Train Analysis—Engine Running, Valve Tappet

Valve tappet noise can be caused by any of the following:

- excessive collapsed valve tappet gap
- sticking valve tappet plunger

- valve tappet check valve not functioning properly
- air in lubrication system
- leakdown rate too rapid
- excessive valve guide wear

Excessive collapsed valve tappet gap can be caused by loose rocker arm seat bolts/nuts, incorrect initial adjustment or wear of valve tappet face, or worn roller valve tappets, push rod (6565), rocker arm (6564), rocker arm seat or valve tip. With valve tappet collapsed, check gap between the valve tip and the rocker arm to determine if any other valve train parts are damaged, worn or out of adjustment.

A sticking valve tappet plunger can be caused by contaminants or varnish inside the valve tappet.

A valve tappet check valve that is not functioning can be caused by an obstruction such as dirt or chips that prevent it from closing when the camshaft lobe is lifting the valve tappet. It may also be caused by a broken check valve spring.

Air bubbles in the lubrication system will prevent the valve tappet from supporting the valve spring load. This can be caused by too high or too low an oil level in the oil pan or by air being drawn into the system through a hole, crack or leaking gasket on the oil pump screen cover and tube.

If the leakdown time is below the specified time for used valve tappets, noisy operation can result. If no other cause for noisy valve tappets can be found, the leakdown rate should be checked and any valve tappets outside the specification should be replaced.

Assembled valve tappets can be tested with Hydraulic Tappet Leakdown Tester to check the leakdown rate. The leakdown rate specification is the time in seconds for the plunger to move a specified distance while under a 22.7 kg (50 lb) load. Test the valve tappets as outlined in this section.



**100% SATISFACTION GUARANTEED**

**BUY IT NOW!**

**Click Here To Order**

PayPal American Express Discover MasterCard VISA

## GENERAL PROCEDURES

### Sprockets

1.  **WARNING:** To avoid the possibility of personal injury or damage to the vehicle, do not operate the engine with the hood open until the fan blade has been examined for possible cracks and separation.

**NOTE:** Specifications show the expected minimum or maximum condition.

**NOTE:** If a component fails to meet the specifications, it is necessary to replace or refinish. If the component can be refinished, wear limits are provided as an aid to making a decision. Any component that fails to meet specifications and cannot be refinished must be replaced.

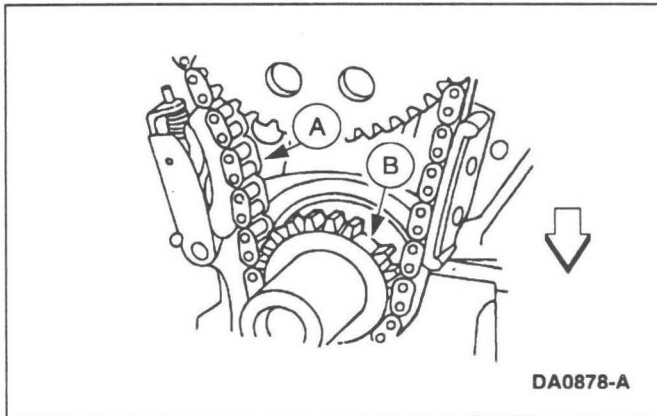

### Rocker Arms —Cleaning

2. Inspect the (A) timing chain/belt and the (B) sprockets.
  - Replace as necessary.

1. Clean all parts thoroughly. Make sure all oil passages are open.
2. Make sure oil passage in the push rod/valve tappet end of the rocker arm (6564) is open.

**100% SATISFACTION GUARANTEED**

**BUY IT NOW!**

**Click Here To Order**



## GENERAL PROCEDURES (Continued)

### Rocker Arms — Inspection

**⚠ CAUTION: Do not attempt to true surfaces by grinding. Check the rocker arm pad, side rails and seat for excessive wear, cracks, nicks or burrs. Check the rocker arm seat bolt for stripped or broken threads. Replace components as required or possible damage may occur.**

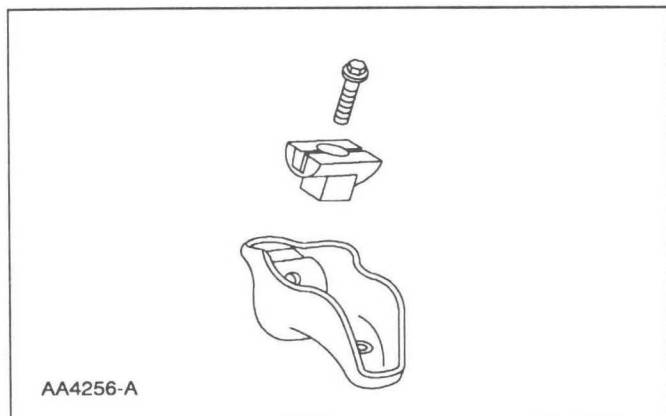

1. Inspect the push rod rocker arm bore for nicks, scratches, scores or scuffs. Replace as necessary.

2. Inspect the pad at the valve end of the rocker arm for indications of scuffing or abnormal wear. If the pad is grooved, replace the rocker arm.

### Push Rods — Cleaning

1. Clean the push rods (6565) in a suitable solvent. Blow out the oil passage in the push rods with compressed air.

### Push Rods — Inspection

1. Check the ends of the push rods for nicks, grooves, roughness or excessive wear. Replace as necessary.

2. **⚠ CAUTION: Do not attempt to straighten push rods.**

The push rods can be checked for straightness while they are installed in the engine by rotating them with the valve closed.

**100% SATISFACTION GUARANTEED**

**BUY IT NOW!**

**Click Here To Order**

## GENERAL PROCEDURES (Continued)

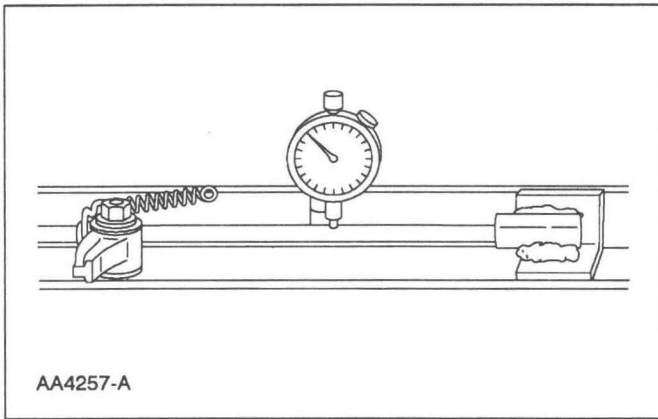

3. They also can be checked with a Dial Indicator with Bracketry.

4. If the push rod is bent beyond specifications, replace it.

## Camshaft Journal — Diameter

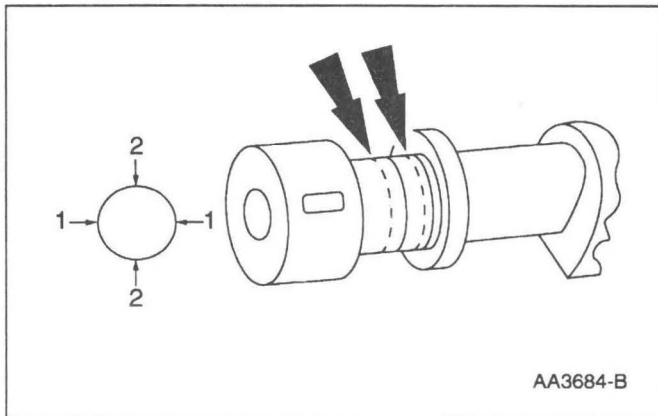

1. Measure each camshaft journal diameter in two directions.
  - If it is out of specification, replace as necessary.

**SATISFACTION  
100%  
GUARANTEED**

**BUY IT NOW!**

**Click Here To Order**

PayPal    American Express    DISCOVER    MasterCard    VISA

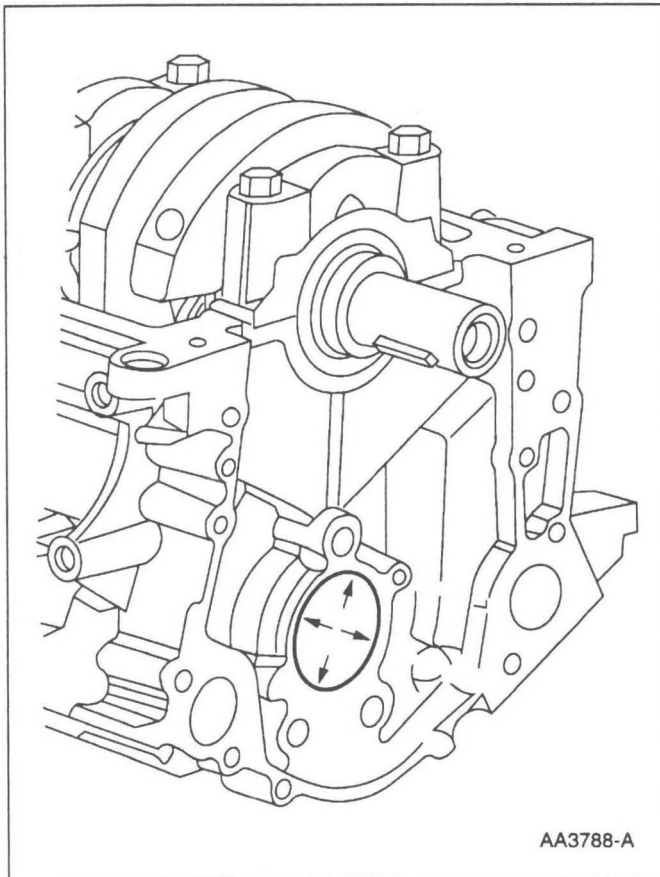
**GENERAL PROCEDURES (Continued)****Camshaft Journal — Clearance, Push Rod Engines, Micrometer Method**

1. **NOTE:** The camshaft journals must meet specifications before checking camshaft journal clearance.

Measure each camshaft bearing (6261) in two directions.

- Subtract the camshaft journal diameter from the camshaft bearing diameter.

**Camshaft Journal — Clearance, Plastigage Method****Special Tool(s)**

<p>ST1280-A</p>	<p>Plastigage 303-D031 (D81L-6002-B) or equivalent</p>
-----------------	--

**NOTE:** The camshaft journals must meet specifications before checking camshaft journal clearance.

1. Remove the camshaft bearing cap and lay plastigage across the surface. Refer to the appropriate section in Group 303 for the procedure.

**100% SATISFACTION GUARANTEED**

**BUY IT NOW!**

**Click Here To Order**

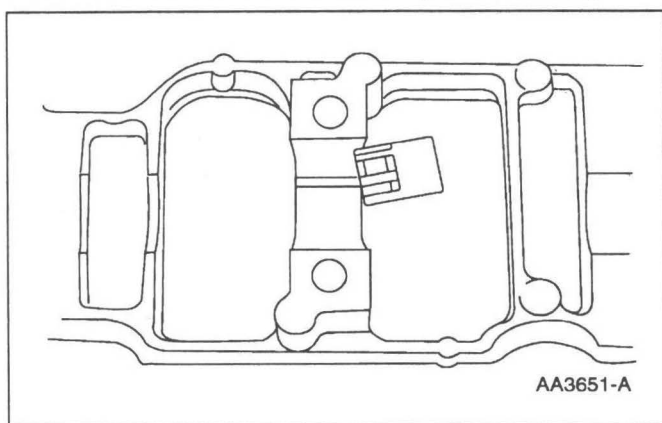
**GENERAL PROCEDURES (Continued)**

- NOTE:** Do not turn the camshaft while doing this procedure.

Position the camshaft bearing cap and install the bolts. Refer to the appropriate engine section.

- Use Plastigage to verify the camshaft journal clearance.
  - If it is out of specification, replace as necessary. Refer to the appropriate section in Group 303 for the procedure.

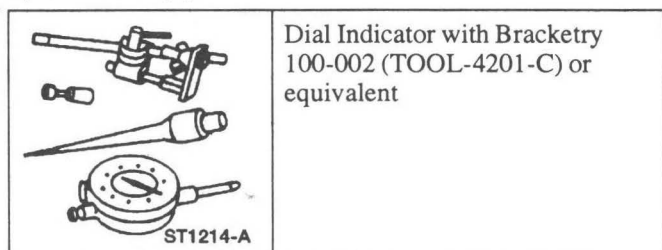
**Camshaft —Push Rod Engines****Special Tool(s)**

- Remove the valve tappets. Refer to the appropriate section in Group 303 for the procedure.
- Use a Dial Indicator with Bracketry to measure camshaft end play.
- Position the camshaft to the rear of the cylinder block.
- Zero the indicator.

**BUY IT NOW!****Click Here To Order**

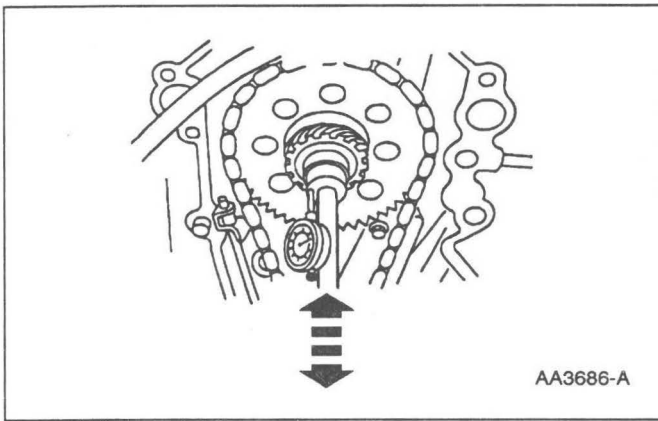
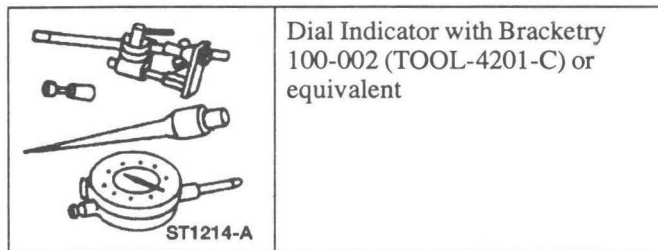
**GENERAL PROCEDURES (Continued)****Camshaft — End Play, OHC Engines****Special Tool(s)**

5. Move the camshaft to the front of the cylinder block. Note and record the camshaft end play.
  - If camshaft end play exceeds specifications, replace the camshaft thrust plate (6269).

1. Remove the roller followers. Refer to the appropriate section in Group 303 for the procedure.
2. Use a Dial Indicator with Bracketry to measure camshaft end play.
3. Position the camshaft to the rear of the cylinder head.
4. Zero the indicator.
5. Move the camshaft to the front of the cylinder head. Note and record the camshaft end play.
  - If camshaft end play exceeds specifications, replace the camshaft thrust bearing washers.

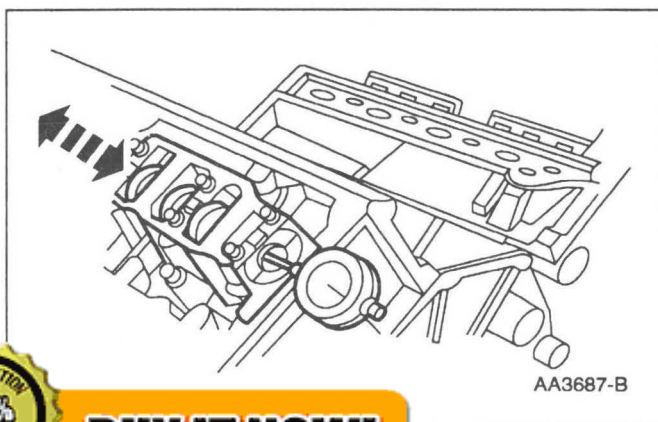

**BUY IT NOW!**

**Click Here To Order**

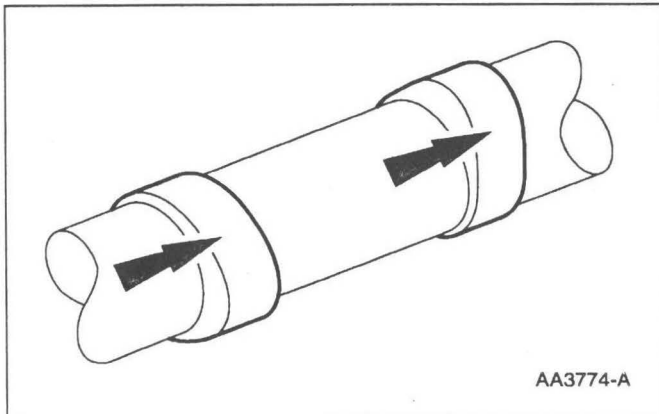

**GENERAL PROCEDURES (Continued)****Camshaft —Lobe Surface**

1. Inspect camshaft lobes for pitting or damage in the active area. Minor pitting is acceptable outside the active area.
  - If excessive pitting or damage is present, replace as necessary.

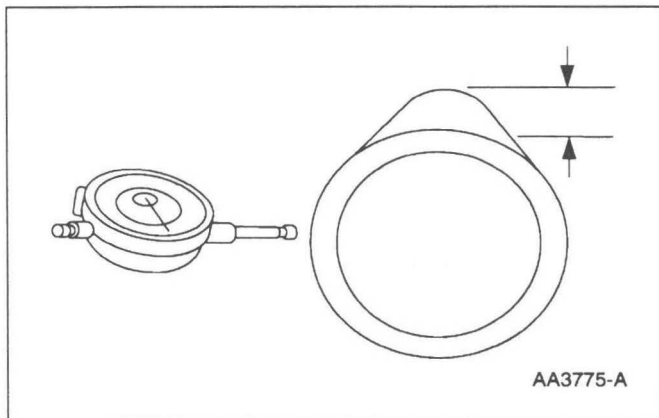
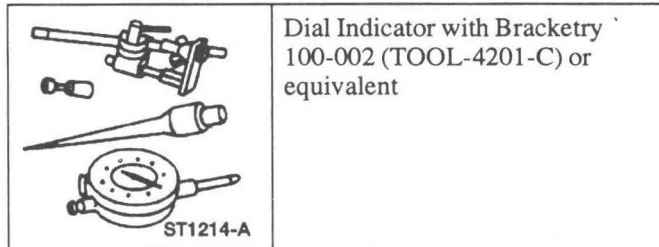
**Camshaft —Lobe Lift****Special Tool(s)**

1. Use a Dial Indicator with Bracketry to measure camshaft intake/exhaust lobe lift.
  - Rotate the camshaft and subtract the lowest indicator reading from the highest indicator reading to figure the camshaft lobe lift.
  - Refer to base engine section for specification.

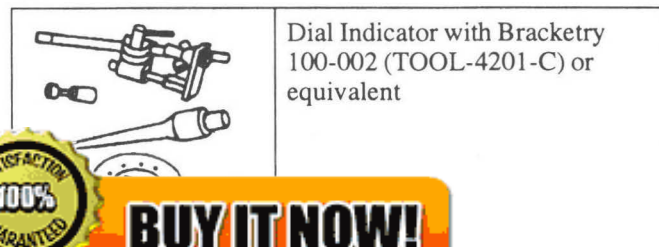
**Camshaft —Runout****Special Tool(s)**

**BUY IT NOW!**

**Click Here To Order**



## GENERAL PROCEDURES (Continued)

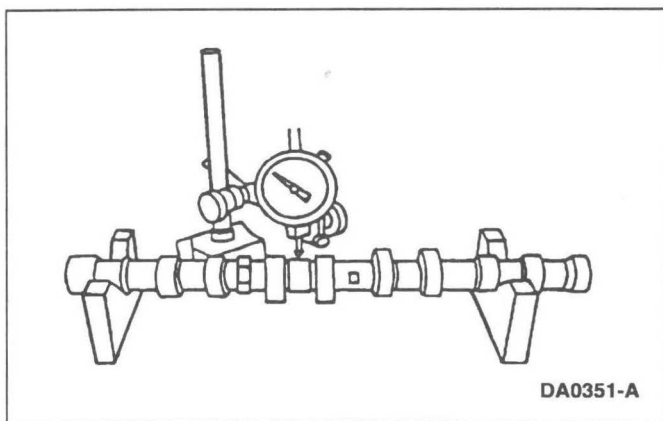

1. **NOTE:** Camshaft journals must be within specifications before checking runout.  
Use a Dial Indicator with Bracketry to measure the camshaft runout.
  - Rotate the camshaft and subtract the lowest indicator reading from the highest indicator reading.
  - Refer to the specification chart in the appropriate engine section.
  - If it is out of specification, replace as necessary.

## Crankshaft Main Bearing Journal —Diameter

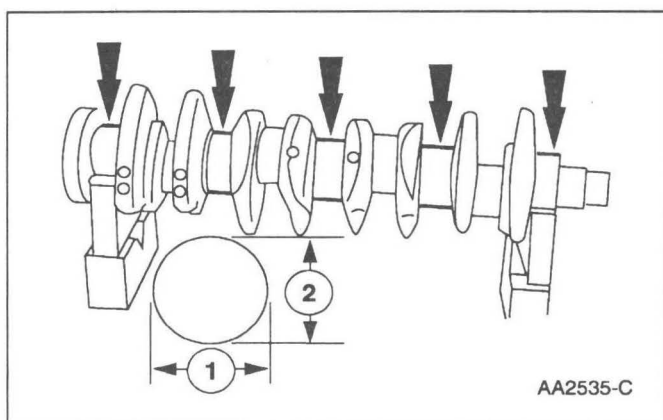

1. Measure each of the crankshaft main bearing journal diameters in at least two directions.
  - Refer to the specification chart in the appropriate engine section.
  - If it is out of specification, replace as necessary.

## Crankshaft Main Bearing Journal —Taper

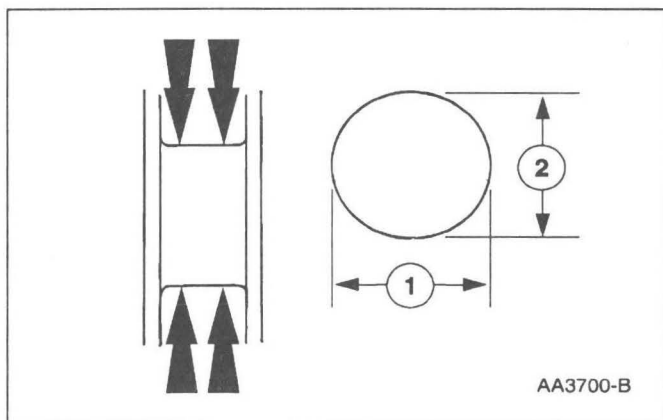

1. Measure each of the crankshaft main bearing journal diameters in at least two directions at each end of the main bearing journal.
  - Refer to the specification chart in the appropriate engine section.
  - If it is out of specification, replace as necessary.



**BUY IT NOW!**

**Click Here To Order**



## GENERAL PROCEDURES (Continued)

## Crankshaft Main Bearing Journal — Clearance

## Special Tool(s)

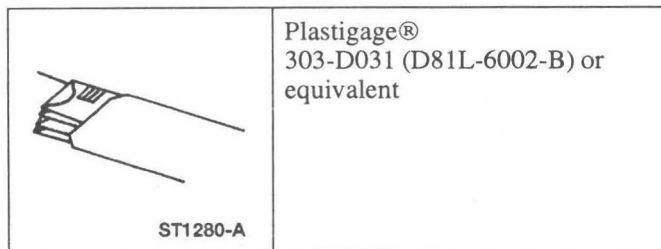

**NOTE:** Crankshaft main bearing journals must be within specifications before checking journal clearance.

1. Remove the crankshaft main bearing caps and crankshaft main bearing.
2. Lay a piece of Plastigage across the face of each crankshaft main bearing surface.

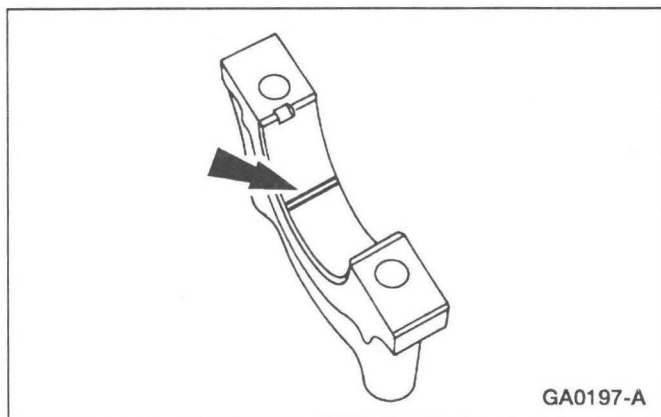

3. **NOTE:** Do not turn the crankshaft while doing this procedure.

Install and remove the crankshaft main bearing cap.

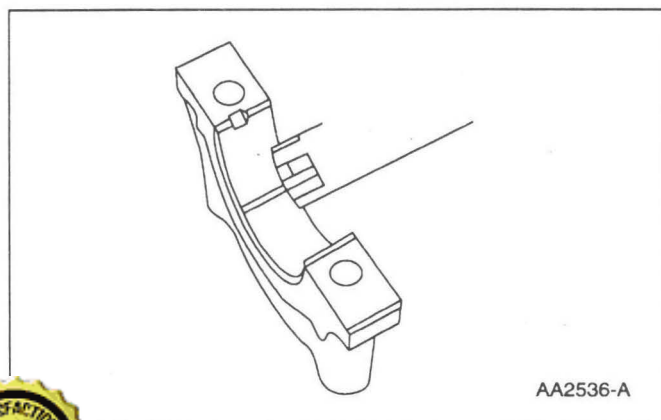

4. Verify the crankshaft journal clearance.
  - Refer to the specification chart in the appropriate engine section.
  - If it is out of specification, replace as necessary.



**BUY IT NOW!**

**Click Here To Order**



## GENERAL PROCEDURES (Continued)

### Crankshaft —End Play

#### Special Tool(s)

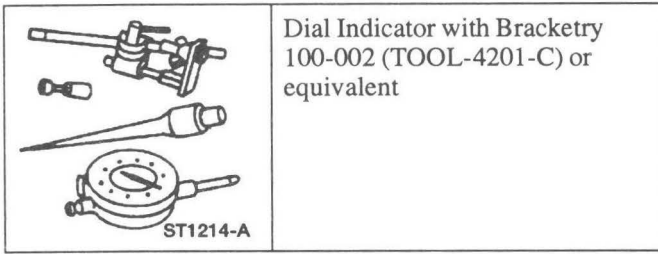

1. Measure the crankshaft end play. Use a Dial Indicator with Bracketry to measure crankshaft end play.
2. Position the crankshaft to the rear of the cylinder block.
3. Zero the indicator.
4. Move the crankshaft to the front of the cylinder block. Note and record the crankshaft end play.
  - If crankshaft end play exceeds specifications, replace the crankshaft thrust washer (6334) or crankshaft thrust main bearing (6337).

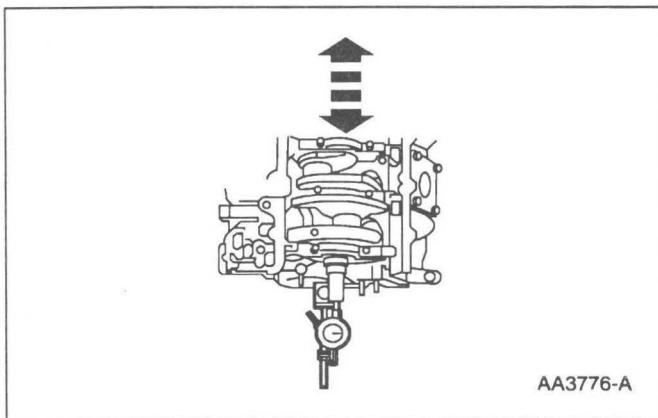

### Crankshaft —Runout

#### Special Tool(s)

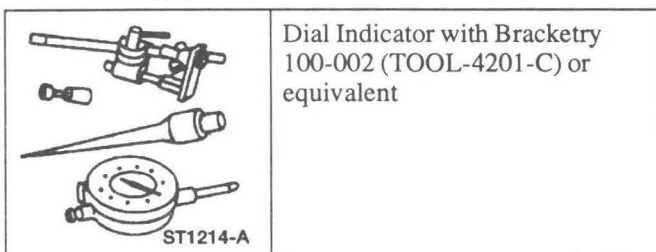

**100% SATISFACTION GUARANTEED**

**BUY IT NOW!**

**Click Here To Order**



## GENERAL PROCEDURES (Continued)

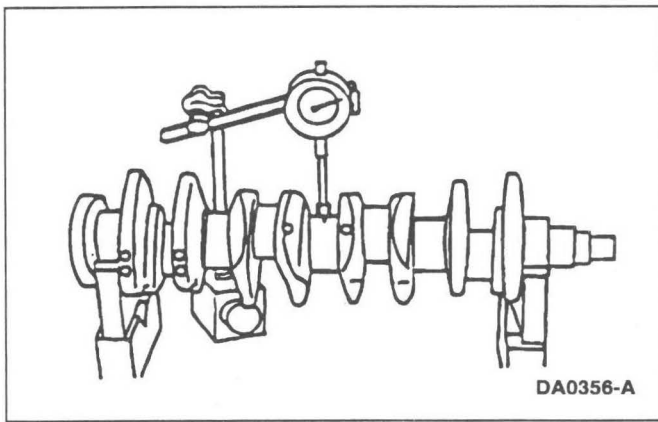

1. **NOTE:** Crankshaft main bearing journals must be within specifications before checking runout.

Use the Dial Indicator with Bracketry to measure the crankshaft runout.

- Refer to the Specification chart in the appropriate engine section. Rotate the crankshaft and subtract the lowest dial indicator reading from the highest dial indicator reading to figure the crankshaft runout. If it is out of specification, replace as necessary.

## Crankshaft—Connecting Rod Journal Taper, Out of Round

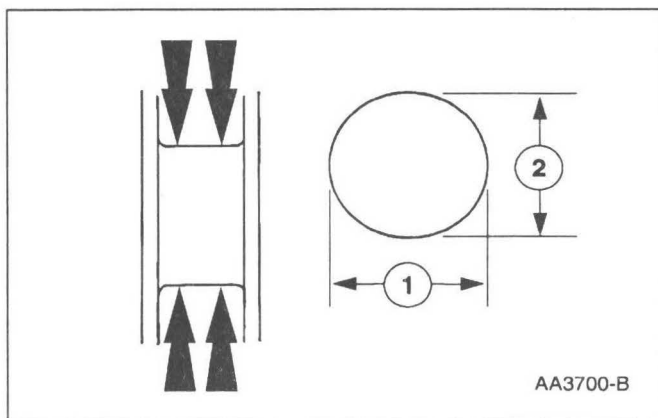

1. Measure the crankshaft connecting rod journal diameters in two directions perpendicular to one another at each end of the connecting rod journal. The difference in the measurements from one end to the other is the taper. Verify measurement is within the wear limit.

- Refer to the appropriate engine section Specification chart.
- If it is out of specification, replace as necessary.

## Cylinder Bore—Taper

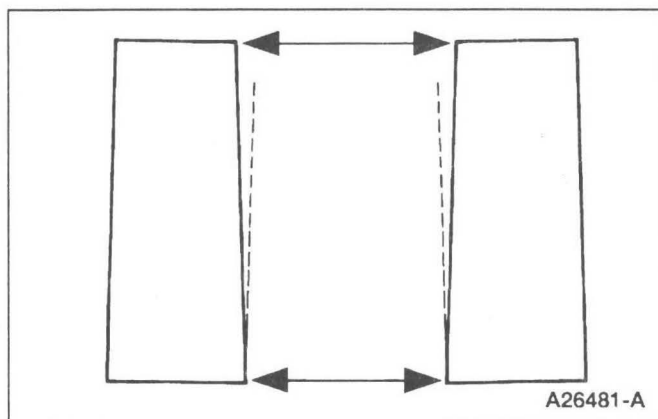

1. Measure the cylinder bore at the top and bottom. Verify the cylinder bore is within the wear limit. The difference indicates the cylinder bore taper. Bore the cylinder to the next oversize.

- Refer to the appropriate engine section Specification chart.



**BUY IT NOW!**

**Click Here To Order**



## GENERAL PROCEDURES (Continued)

### Cylinder Bore — Out-of-Round

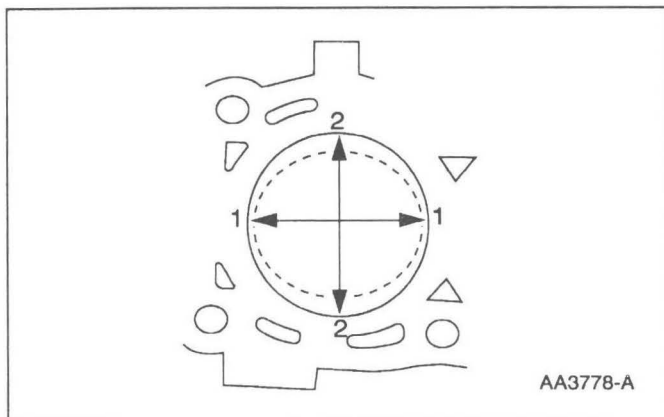

1. Measure the cylinder bore in two directions. The difference is the out-of-round. Verify the out-of-round is within the wear limit and bore the cylinder to the next oversize limit.
  - Refer to the appropriate engine section Specification Chart.

### Piston — Inspection

#### Special Tool(s)

	<p>Piston Ring Groove Cleaner 303-D033 (D81L-6002-D) or equivalent</p>
--	--

**⚠ CAUTION:** Do not use a caustic cleaning solution or a wire brush to clean the pistons or damage can occur.

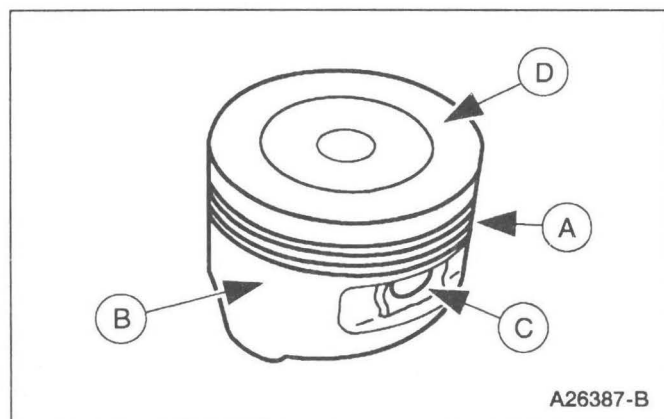

1. Clean and inspect the (A) ring lands, (B) skirts, (C) pin bosses, and the (D) tops of the pistons. If wear marks, scores or glazing is found on the piston skirt, check for a bent or twisted connecting rod.

**100% SATISFACTION GUARANTEED**

**BUY IT NOW!**

**Click Here To Order**



**TECHNICAL  
SUPPORT OPERATIONS**

Ford Customer Service Division

**100% SATISFACTION GUARANTEED**

**BUY IT NOW!**

**Click Here To Order** 

PayPal    

LITHO IN U.S.A.  
PG - 1928



FCS-12272-99-2