

100% MONEY BACK GUARANTEE

BUY IT NOW!

Click Here To Order

1 . 9 . 9 . 9

F-150 F-250

DEMO

This DEMO contains only a few pages of the entire manual/product.

Not all Bookmarks work on the Demo, but they do on the full version.

Features:

- Searchable text
- Printable pages
- Bookmarked for easy navigation
- High Resolution images
- Zoom to see exact details
- Money back Guarantee
- Available on USB and eBook download



Buy Now



WIRING DIAGRAMS



License #84356800

Copyright © 2024, Forel Publishing Company, LLC, Woodbridge, Virginia

All Rights Reserved. No part of this book may be used or reproduced in any manner whatsoever without written permission of Forel Publishing Company, LLC. For information write to Forel Publishing Company, LLC, Woodbridge, VA 22192

1999 Ford F-150 F-250 Truck Wiring Diagrams

EAN: 978-1-60371-482-2

ISBN: 1-60371-482-0

Forel Publishing Company, LLC
Woodbridge, VA 22192
Email: sales@ForelPublishing.com
<https://www.ForelPublishing.com>



License #84356800

This publication contains material that is reproduced and distributed under a license from Ford Motor Company. No further reproduction or distribution of the Ford Motor Company material is allowed without the express written permission of Ford Motor Company.

Note from the Publisher

This product was created from the original Ford Motor Company's publication. Every effort has been made to use the original scanned images, however, due to the condition of the material; some pages have been modified to remove imperfections.

Disclaimer

Although every effort was made to ensure the accuracy of this book, no representations or warranties of any kind are made concerning the accuracy, completeness or suitability of the information, either expressed or implied. As a result, the information contained within this book should be used as general information only. The author and Forel Publishing Company, LLC shall have neither liability nor responsibility to any person or entity with respect to any loss or damage caused, or alleged to be caused, directly or indirectly by the information contained in this book. Further, the publisher and author are not engaged in rendering legal or other professional services. If legal, mechanical, electrical, or other expert assistance is required, the services of a competent professional should be sought.



WIRING DIAGRAMS FCS-12263-99

FORD CUSTOMER SERVICE DIVISION

Quality is Job 1

Ford Customer Service Division has continued with the existing format for the 1999 F-150/250 Wiring Diagrams. Our goal is to provide accurate and timely electrical service information.

1999 WIRING DIAGRAMS FEATURES

- Schematic pages contain **Component Location** references to full-view illustrations and **Component Descriptions** that describe the system function of a component.
- **"COMPONENT TESTING"** procedures (CELL 149) tell the user how to perform diagnostic tests on various circuits.
- **Connector End Views** are located at the end of individual cells and are shown for connectors with five or more cavities; for connectors with ten or more cavities, a circuit function chart is provided.
- **NOTES, CAUTIONS and WARNINGS** contain important safety information.
- Full view **"COMPONENT LOCATION VIEWS"** (CELL 151) help locate on-vehicle components.
- Circuit voltages are included on schematic pages to help simplify troubleshooting.
- **Cellular Pagnation:** A specific section (or cell) in all Wiring Diagrams is numbered by cell and starts with page 1. For example: **"HOW TO USE THIS MANUAL"** is CELL 2 and begins with page 2-1.
- **"IN-LINE CONNECTOR FACES"** (CELL 150) are included for in-line connectors with six or more terminals, to aid in servicing electrical wiring.
- **"C"** numbers are assigned for all electrical connectors. **"C"** numbers are listed in the **"LOCATION INDEX"** (CELL 152).
- **"HARNES CAUSAL PART NUMBERS"** (CELL 153) are included to aid in identifying warranty concerns.

ORDERING INFORMATION

Information about how to order additional copies of this publication or other Ford publications may be obtained by writing to Helm Incorporated at the address shown below or by calling 1-800-782-4356. Other publications available include:

- Workshop Manuals
- Service Specification Books
- Powertrain Control/Emissions Diagnosis Manuals

Helm Incorporated
P.O. Box 07150
Detroit, Michigan 48207



"HARNES CAUSAL PART NUMBERS" contain a suffix to denote connector "gender" type

1-1 TABLE OF CONTENTS/INDEX

1999 F-150/250

Table of Contents

How to Use This Manual	2-1
Grounds	10-1
Fuse Panel/Circuit Protection	11-1
Charging System	12-1
Power Distribution	13-1
Multiplex Communication Network	14-1
Starting System	20-1
Ignition System	21-1
Engine Controls (4.2L)	23-1
Engine Controls (4.6L)	24-1
Engine Controls (5.4L)	25-1
Engine Controls (5.4L NGV)	26-1
Transmission Controls (4R70W)	29-1
Transmission Controls (4R100)	30-1
Speed Control	31-1
Electric Shift Control	34-1
Shift Lock	37-1
Rear Air Suspension (RAS)	41-1
Anti-Lock Brake System (ABS)	42-1
Horn/Cigar Lighter	44-1
Air Bags	46-1
Heater	53-1
Air Conditioner/Heater	54-1
Multifunction Electronic Control	
Modules	59-1
Instrument Cluster	62-1
Warning Chime	66-1
Instrument Illumination	71-1
Interval Wiper/Washer	81-1
Headlamps	85-1
Fog Lamps	86-1
Lenses	87-1
Switches	89-1
Wiring	90-1
Wipers	92-1
Washers	93-1

Trailer/Camper Adapter	95-1
Daytime Running Lamps (DRL)	97-1
Power Windows	100-1
Power Door Locks	110-1
Anti-Theft	112-1
Remote Control Alarm And Lock	
System	117-1
Power Seats	120-1
Power Mirrors	124-1
Radio	130-1
Component Testing	149-1
In-Line Connector Faces	150-1
Component Location Views	151-1
Location Index	152-1
Harness Causal Part Number	153-1
Vehicle Repair Location Codes	160-1

Index

Air Bags	46-1
Air Conditioner/Heater	54-1
Anti-Lock Brakes	42-1
Anti-Theft	112-1
Battery Junction Box:	
Diode (A/C Clutch)	54-3
Diode (PCM Power)	13-12
Maxifuse 101	13-3
Maxifuse 102	13-3, 7
Maxifuse 103	13-4
Maxifuse 104	13-3
Maxifuse 105	13-4
Maxifuse 108	13-6
Maxifuse 109	13-5
Maxifuse 110	13-6
Maxifuse 111	13-4, 7
Maxifuse 112	13-4
Maxifuse 113	13-4, 7

Minifuse 1	13-3
Minifuse 2	13-5
Minifuse 3	13-2
Minifuse 4	13-5
Minifuse 5	13-1
Minifuse 6	13-2
Minifuse 7	13-2
Minifuse 8	13-6
Minifuse 9	13-3
Minifuse 10	13-4
Minifuse 11	13-1
Minifuse 18	23-1, 24-1, 25-1, 26-1
Minifuse 19	95-2
Minifuse 20	95-2
Minifuse 23	23-1, 24-1, 25-1, 26-1
Minifuse 24	23-1, 24-1, 25-1, 26-1

Central Junction Box:

Fuse 1	13-8
Fuse 2	13-8
Fuse 3	13-8
Fuse 4	13-8
Fuse 5	13-9
Fuse 6	13-10
Fuse 8	13-10
Fuse 11	13-10
Fuse 13	13-9
Fuse 14	13-9
Fuse 15	13-9
Fuse 16	85-1, 87-3
Fuse 18	13-11
Fuse 20	13-14
Fuse 21	13-14
Fuse 22	13-14
Fuse 23	13-15
Fuse 24	13-14
Fuse 25	13-15
Fuse 26	85-1, 86-2, 87-3

100% SATISFACTION GUARANTEED

BUY IT NOW!

Click Here To Order

PayPal American Express Discover MasterCard VISA

TABLE OF CONTENTS/INDEX 1-2

1999 F-150/250

Fuse 27	85-1, 86-2, 87-3
Fuse 28	85-1, 86-2, 87-3
Fuse 29	13-12
Fuse 30	13-12
Charging System	12-1
Cigar Lighter	44-2
Courtesy Lamps	89-1
Daytime Running Lamps (DRL)	97-1
Door Locks	110-1
Electric Shift Control	34-1
Fuse Panel/Circuit Protection	11-1
Generic Electronic Module (GEM)/ Central Timer Module (CTM)	59-1
Grounds:	
G100	10-1
G101	10-1
G102	10-2
G103	10-5, 10
G104	10-6
G200	10-2, 7
G201	10-9
G202	10-10
G400	10-10
Heater	53-1
Horns	44-1
Ignition System	21-1
Indicators:	
4×4 High Range	62-3
4×4 Low Range	62-3
Air Bag	62-1
Anti-Lock	62-4
Brake	62-1
Brake Light	62-1
Turn Signal	62-1
Washer	62-4
Wiper	62-1

High Beam	62-5
Left Turn	62-5
Low Fuel	62-3
Low Oil Pressure/High Coolant Temperature	62-3
Malfunction	62-3
Right Turn	62-5
Instrument Cluster	62-1
Instrument Illumination	71-1
Interval Wiper/Washer	81-1
Lamps (Exterior):	
Autolamps	87-1
Engine Compartment	89-1
Fog	86-1
Headlamps	85-1
License	92-2
Park	92-1
Reversing	93-1
Stop	90-2
Turn	90-2
Lamps (Interior):	
Cargo	89-2
Glove Compartment	89-1
Illumination	62-4
Interior	89-2
Interior/Map	89-2
Mirrors	124-1
Radio:	
AM/FM w/Cassette	130-1
CD Player	130-4
Premium Sound	130-2, 3
Rear Air Suspension (RAS)	41-1
Remote Anti-Theft Personality (RAP) Module	117-1
Seats	120-1
Shift Lock	37-1
Speed Control	31-1

Starting System	20-1
Trailer/Camper Adapter	95-1
Transmission Controls (4R70W)	29-1
Transmission Controls (4R100)	30-1
Warning Chime	66-1
Windows	100-1

IMPORTANT SAFETY NOTICE

Appropriate service methods and proper repair procedures are essential for the safe, reliable operation of all motor vehicles, as well as the personal safety of the individual doing the work. This Manual provides general directions for accomplishing service and repair work with tested, effective techniques. Following them will help to assure reliability.

There are numerous variations in procedures, techniques, tools, and parts for servicing vehicles, as well as in the skill of the individual doing the work. This Manual cannot possibly anticipate all such variations and provide advice or cautions as to each. Accordingly, anyone who departs from the instructions provided in this Manual must first establish that the choice of methods, tools or parts does not compromise personal safety or the vehicle integrity.



BUY IT NOW!
Click Here To Order







2-1 HOW TO USE THIS MANUAL

1999 F-150/250

The purpose of this manual is to show electrical circuits in a clear and simple fashion to make troubleshooting easier. **NOTES, CAUTIONS** and **WARNINGS** contain important information.

- **NOTES** describe how switches and other components operate to help complete a particular procedure.
- **CAUTIONS** provide information that could prevent making an error that may damage the vehicle.
- **WARNINGS** provide information to prevent personal injury.

The **WARNINGS** list on page 2-2 contains general warnings to follow when servicing a vehicle.

Components that work together are shown together. All electrical components used in a specific system are shown on one diagram. The circuit breaker or fuse is shown at the top of the page. All wires, connectors, components and splices are shown in the flow of current to ground at the bottom of the page. If a component is used in several different systems, it is shown in several places. For example, the Main Light Switch is electrically a part of many systems and is repeated on many pages.

In some cases, a component may seem (by its name) to belong to a system where it has no electrical connection. For example, Radio Illumination is electrically part of Instrument Illumination, but because it has no electrical connection to the Radio system, it is not shown on the Radio diagram.

Schematic pages contain references to full-view illustrations and description notes for various components. The references are reverse-text blocks that point to the full-view illustration page and describe the

Schematic pages contain circuit voltages to help simplify troubleshooting hints. 12V is used to imply battery voltage on a component connector terminal, and 0V is used to show that there should be continuity to ground on that particular terminal. Conditional voltages such as "12V with the ignition switch in RUN" will also be provided. Troubleshooting hints that can't be simplified with circuit voltages will be shown at the end of each cell.

Component connector face information specific to a certain cell is found at the end of that cell. A Connector Face Reference List is provided to locate connector faces that are shown in different cells. Component connectors with five or more terminals are illustrated and are accompanied by a pinout chart that lists the function of all circuitry associated with that component.

"GROUNDS" (Cell 10) contains ground circuitry shown in complete detail. This information is useful for checking interconnections of the ground circuits of different systems.

"POWER DISTRIBUTION" (Cell 13) contains power distribution circuitry shown in complete detail. This section displays how the various fuses are powered and, in turn, how each system is powered.

"COMPONENT TESTING" (Cell 149) contains testing procedures for various switches. This information includes schematics, component terminal locations and step-by-step procedures.

"IN-LINE CONNECTOR FACES" (Cell 150) contains illustrations of all the in-line connectors that have 6 or more terminals. The terminals have pin numbers assigned to them.

"COMPONENT LOCATION VIEWS" (Cell 151) contains full-view illustrations which show the location of all components and connectors in the vehicle.

The **"LOCATION INDEX"** (Cell 152) provides the base part numbers, locations, connector face references and illustration references for all components, connectors, splices and grounds.

HELPFUL REMINDERS

Before using the wiring diagrams for troubleshooting, refer to these HELPFUL REMINDERS:

1. The abbreviation T/O, for take out, used in the Location Index (Cell 152), refers to the point at which a group of wires branch off the harness trunk. Refer to the wiring harness illustration.

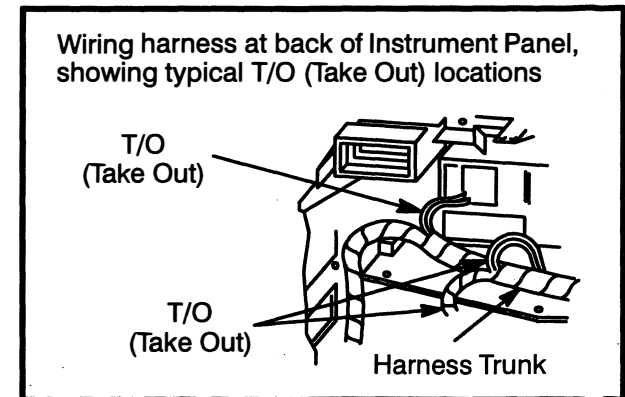

2. If a connector serves the same purpose in two separate versions (e.g., Automatic/Manual), but is physically different, *two* connector numbers are used. However, if a connector serves the same purpose in two separate versions (e.g., Automatic/Manual) and is physically the same, but the wire colors are different, only *one* connector number is used. If the same physical connector is used more than once, then more than *one* connector number is used.

100% SATISFACTION GUARANTEED

BUY IT NOW!

Click Here To Order

PayPal Discover Cards Discover Rewards MasterCard VISA

3. Wiring schematics provide a picture of how and under what conditions the circuit is powered, of the current path to circuit components, and of how a circuit is grounded. Each circuit component is named (underlined titles). Wire and connector colors are listed as follows (standard Ford color abbreviations are used):

COLOR ABBREVIATIONS

BU	Blue	NA	Natural
BK	Black	OG	Orange
BN	Brown	PK	Pink
DB	Dark Blue	VT	Purple
DG	Dark Green	RD	Red
GN	Green	SR	Silver
GY	Gray	TN	Tan
LB	Light Blue	WH	White
LG	Light Green	YE	Yellow

Note: Whenever a wire is labeled with two colors, the first color listed is the basic color of the wire, and the second color listed is the stripe marking of the wire.

4. When reporting Vehicle Repair Location Codes to Ford Customer Service Division, refer to Cell 160 (beginning on page 160-1). Note: Do *not* use the illustrations in Cell 151 (beginning on page 151-1) for reporting Vehicle Repair Location Codes.

5. WARNINGS

- *Always wear safety glasses for eye protection.*
- *Use safety stands whenever a procedure requires being under a vehicle.*
- *Be sure that the Ignition Switch is always in the OFF position, unless otherwise required by the procedure.*
- *Set the parking brake when working on any vehicle. An automatic transmission should be in PARK. A manual transmission should be in NEUTRAL.*
- *Operate the engine only in a well-ventilated area to avoid danger of carbon monoxide.*
- *Keep away from moving parts, especially the fan and belts, when the engine is running.*
- *To prevent serious burns, avoid contact with hot metal parts such as the radiator, exhaust manifold, tail pipe, catalytic converter and muffler.*
- *Do not allow flame or sparks near the battery. Gases are always present in and around the battery cell. An explosion could occur.*
- *Do not smoke when working on a vehicle.*
- *To avoid injury, always remove rings, watches, loose hanging jewelry and avoid wearing loose clothing.*

HOW TO FIND ELECTRICAL CONCERNS

TROUBLESHOOTING STEPS

These six steps present an orderly method of troubleshooting.

Step 1. Verify the concern.

- Operate the complete system to check the accuracy and completeness of the customer's complaint.

Step 2. Narrow the concern.

- Using the wiring diagrams, narrow down the possible causes and locations of the concern to pinpoint the exact cause.
- Read the description notes at the components and study the wiring schematic. You should then know enough about the circuit operation to determine where to check for the trouble. Further information can be found by referring to the Service Manual pages listed in the box at the top of the page.

Step 3. Test the suspected cause.

- Use electrical test procedures to find the specific cause of the symptoms.
- The component location reference bars and the pictures will help you find components. The Location Index (at the end of the manual) gives component location information for connectors, diodes, resistors, splices and grounds.

Step 4. Verify the cause.

- Confirm that you have found the correct cause by connecting jumper wires and/or temporarily installing a known good component and operating the circuit.

Step 5. Make the repair.

- Repair or replace the inoperative component.

Step 6. Verify the repair.

- Operate the system as in Step 1 and check that your repair has removed all symptoms without creating any new symptoms.

100% SATISFACTION GUARANTEED

BUY IT NOW!

Click Here To Order

PayPal American Express Discover MasterCard VISA

2-3 HOW TO USE THIS MANUAL

1999 F-150/250

Some engine circuits may need special test equipment and special procedures. See the *Service Manual* and other service books for details. You will find the circuits in this manual to be helpful with those special test procedures.

TROUBLESHOOTING TOOLS

JUMPER WIRE

This is a test lead used to connect two points of a circuit. A Jumper Wire can bypass an open to complete a circuit.

WARNING

Never use a jumper wire across loads (motors, etc.) connected between hot and ground. This direct battery short may cause injury or fire.

VOLTMETER

A DC Voltmeter measures circuit voltage. Connect negative (- or black) lead to ground, and positive (+ or red) lead to voltage measuring point.

OHMMETER

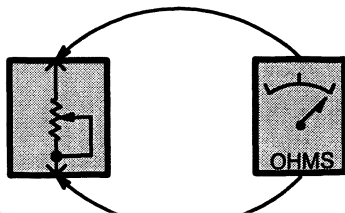

100% SATISFACTION GUARANTEED

BUY IT NOW!

Click Here To Order

PayPal Discover American Express MasterCard VISA

An Ohmmeter shows the resistance between two connected points (Figure 1).

TEST LAMP

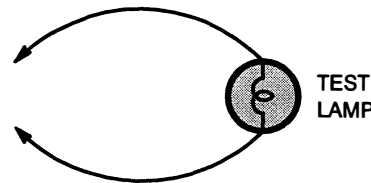

Figure 2 – Test Lamp

A Test Light is a 12-volt bulb with two test leads (Figure 2).

Uses: Voltage Check, Short Check.

SELF-POWERED TEST LAMP

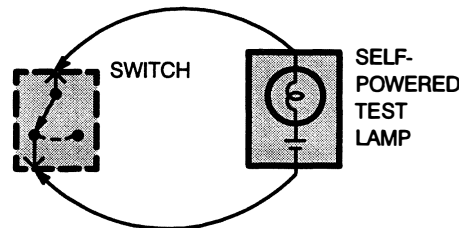

Figure 3 – Continuity Check

The Self-Powered Test Lamp is a bulb, battery and set of test leads wired in series (Figure 3). When connected to two points of a continuous circuit, the bulb glows.

Uses: Continuity Check, Ground Check.

CAUTION

When using a self-powered test lamp or ohmmeter, be sure power is off in circuit during testing. Hot circuits can cause equipment damage and false readings.

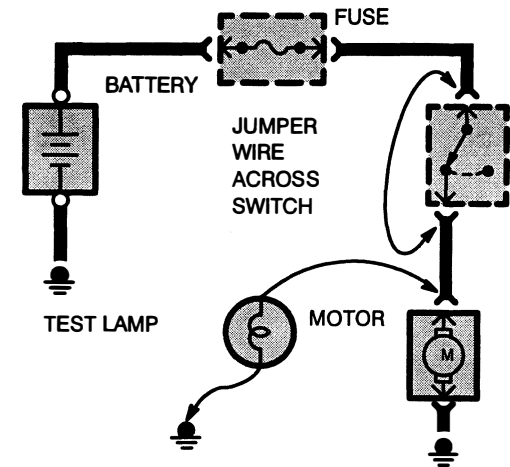

Figure 4 – Switch Circuit Check and Voltage Check

In an inoperative circuit with a switch in series with the load, jumper the terminals of the switch to power the load. If jumpering the terminals powers the circuit, the switch is inoperative (Figure 4).

CONTINUITY CHECK (Locating open circuits)

Connect one lead of Self-Powered Test Lamp or Ohmmeter to each end of circuit (Figure 3). Lamp will glow if circuit is closed. Switches and fuses can be checked in the same way.

VOLTAGE CHECK

Connect one lead of test lamp to a known good ground or the negative (-) battery terminal. Test for voltage by touching the other lead to the test point. Bulb goes on when the test point has voltage (Figure 4).

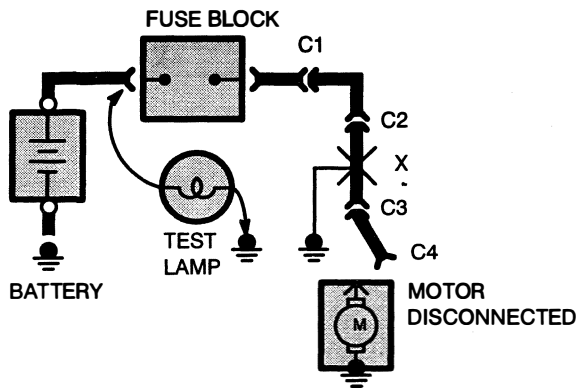

Figure 5 – Short Check

A fuse that repeatedly blows is usually caused by a short to ground. It's important to be able to locate such a short quickly (Figure 5).

1. Turn off everything powered through the fuse.
2. Disconnect other loads powered through the fuse:
 - Motors: disconnect motor connector (Connector C4 in Figure 5).
 - Lights: remove bulbs.

4. Connect one Test Lamp lead to hot end of blown fuse. Connect other lead to ground. Bulb should glow, showing power to fuse. *(This step is just a check to be sure you have power to the circuit.)*
5. Disconnect the test lamp lead that is connected to ground, and reconnect it to the load side of the fuse at the connector of the disconnected component. (In Figure 5, connect the test lamp lead to connector C4.)
 - If the Test Lamp is off, the short is in the disconnected component.
 - If the Test Lamp goes on, the short is in the wiring. You must find the short by disconnecting the circuit connectors, one at a time, until the Test Lamp goes out. For example, in Figure 5 with a ground at X, the bulb goes out when C1 or C2 is disconnected, but not after disconnecting C3. This means the short is between C2 and C3.

Turn on power to the circuit. Perform a Voltage Check between the suspected inoperative ground and the frame. Any indicated voltage means that the ground is inoperative (Figure 6).

Turn off power to the circuit. Connect one lead of a Self-Powered Test Lamp or Ohmmeter to the wire in question and the other lead to a known ground. If the bulb glows, the circuit ground is OK (Figure 6).

The circuit schematics in this manual make it easy to identify common points in circuits. This knowledge can help narrow the concern to a specific area. For example, if several circuits fail at the same time, check for a common power or ground connection (see *Power Distribution* or *Grounds*). If part of a circuit fails, check the connections between the part that works and the part that doesn't work.

For example, if the lo beam headlamps work, but the high beams and the indicator lamp don't work, then power and ground paths must be good. Since the dimmer switch is the component that switches this power to the high beam lights and indicator, it is most likely the cause of failure.

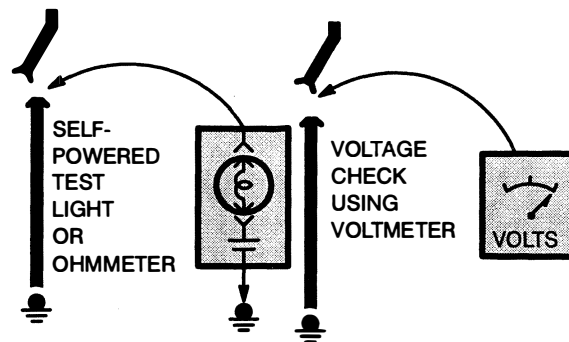

Figure 6 – Ground Check

Turn Ignition Switch to RUN (if necessary) to

100% SATISFACTION GUARANTEED

BUY IT NOW!

Click Here To Order

2-5 HOW TO USE THIS MANUAL

1999 F-150/250

TROUBLESHOOTING WIRING HARNESS AND CONNECTOR HIDDEN CONCERNS

The following illustrations are known examples of wiring harness, splices and connectors that will create intermittent electrical concerns. The concerns are hidden and can only be discovered by a physical evaluation as shown in each illustration.

NOTE: Several components, such as the PCM, utilize gold plated terminals in their connections to the wiring harness. If those terminals need to be replaced, they must be replaced with a gold plated terminal.

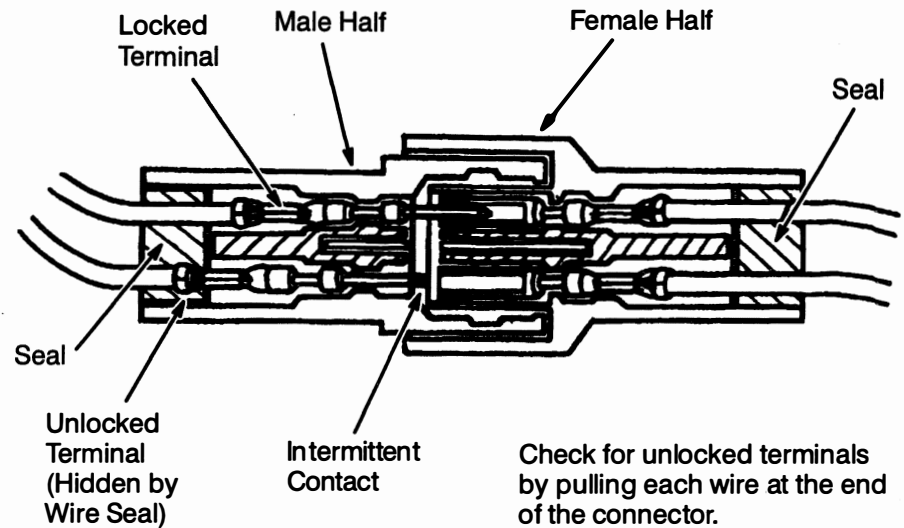

TERMINAL NOT PROPERLY SEATED

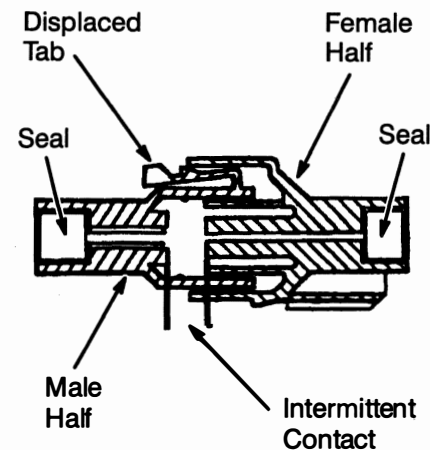
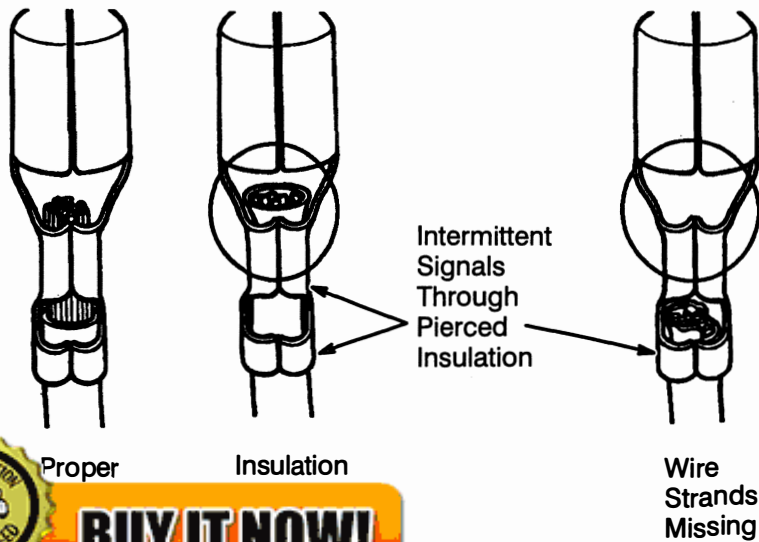

Lock may be displaced into an unlocked position; pull on the connector to verify the lock.

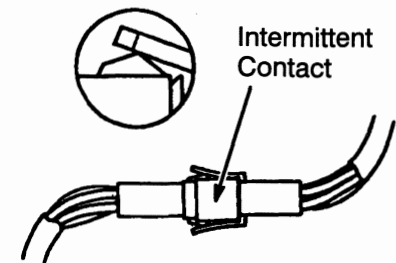

Type A

Type B

PARTIALLY MATED CONNECTORS

100% SATISFACTION GUARANTEED

BUY IT NOW!

[Click Here To Order](#)

PayPal, American Express, Discover, MasterCard, VISA

WIRE STRIPPING

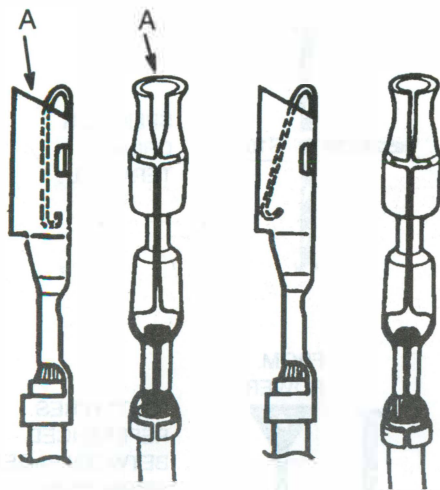

Enlarged

Normal

DEFORMED (ENLARGED) FEMALE TERMINALS

Any probe entering the terminal may enlarge the contact spring opening creating an intermittent signal. Insert the correct mating terminal (Location A) from the service kit and feel for a loose fit.

Solder Coated Wire to Ground

Solder coated wire pierced through the insulation of another circuit.

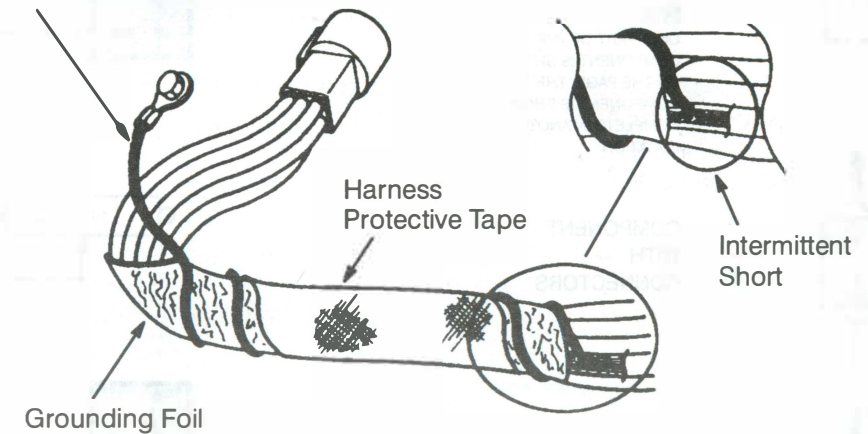

ELECTRICAL SHORT INSIDE THE HARNESS

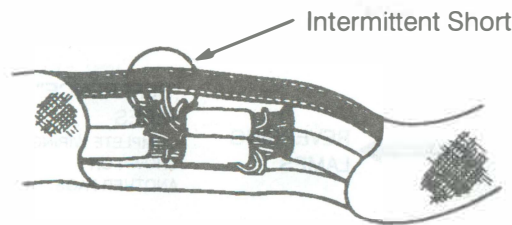

Splice Tape Removed

Operate the system and flex the harness at splice location noted in Section 152.

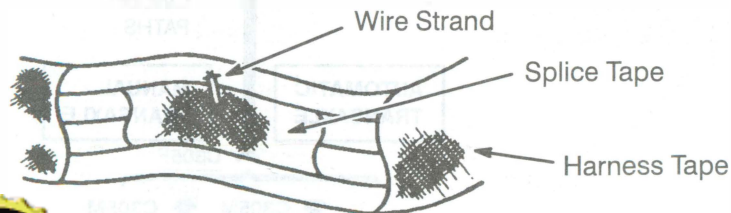

Wire Strand

Splice Tape

Harness Tape

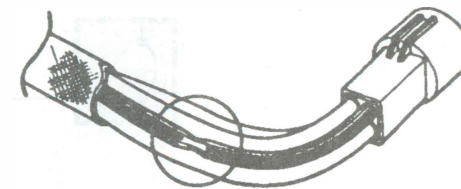

Wiring Harness Tape

Remove the tape and flex/feel each circuit for a reduction in diameter at break.

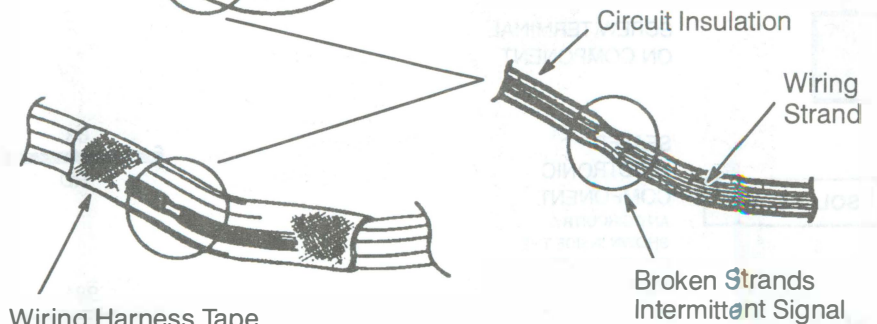

Circuit Insulation

Wiring Strand

Broken Strands
Intermittent Signal

BROKEN WIRE STRANDS IN HARNESS

WITHIN THE HARNESS

100% SATISFACTION GUARANTEED

BUY IT NOW!

Click Here To Order

PayPal American Express Discover MasterCard VISA

2-7 HOW TO USE THIS MANUAL

1999 F-150/250

ELECTRICAL SYMBOLS

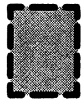

DASHED COMPONENT BOX
ONLY PART OF THE COMPONENT IS SHOWN ON THE PAGE; THE COMPONENT IS SHOWN COMPLETE IN ANOTHER LOCATION

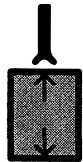

COMPONENT WITH CONNECTORS

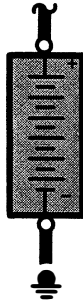

BATTERY



SCREW TERMINAL ON COMPONENT

SOLID STATE

SEALED ELECTRONIC COMPONENT
ANY CIRCUITRY SHOWN INSIDE THE BOX IS A FUNCTIONAL EQUIVALENT ONLY



BUY IT NOW!

Click Here To Order

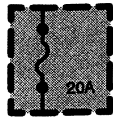

FUSE
CURRENT RATING

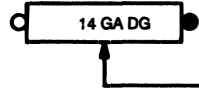

FUSIBLE LINK
WIRE SIZE AND COLOR

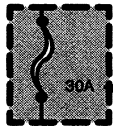

MAXI-FUSE OR FUSIBLE LINK CARTRIDGE
CURRENT RATING

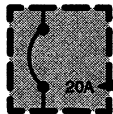

CIRCUIT BREAKER
CURRENT RATING



SOLID WIRES

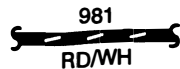

STRIPED WIRES

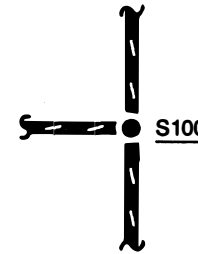

SPLICE OR CRIMP TERMINAL

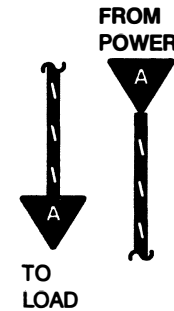

"CUT" WIRES REFERENCED BETWEEN PAGES
ARROWS SHOW CURRENT FLOW FROM POWER TO GROUND



"REFERENCE" WIRES
COMPLETE WIRING SHOWN ON ANOTHER PAGE

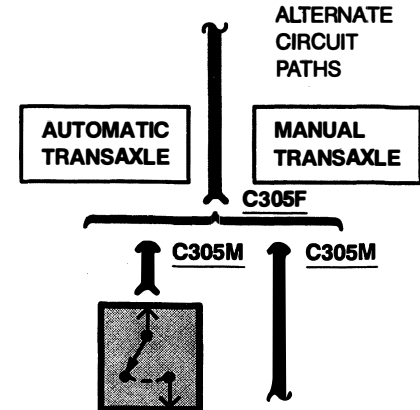

ALTERNATE CIRCUIT PATHS

AUTOMATIC TRANSAXLE **MANUAL TRANSAXLE**

C305F

C305M

C305M

ELECTRICAL SYMBOLS

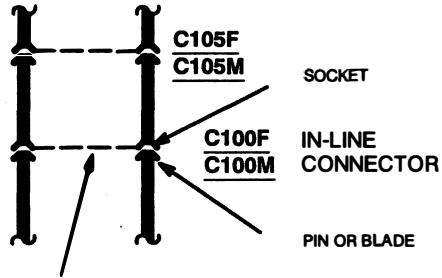

SINGLE DASHED LINE INDICATES THAT WIRE ON LEFT ALSO PASSES THROUGH THE SAME CONNECTOR

SEE GROUNDS
PAGES 10-1,
10-2

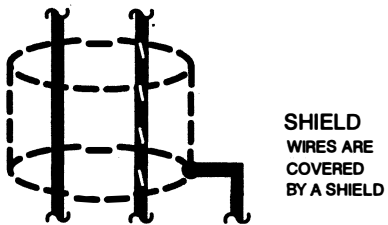
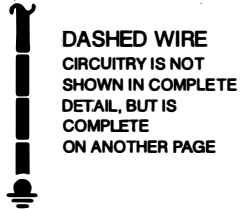

MOTOR



HEATING ELEMENT



THERMISTOR



RHEOSTAT OR POTENTIOMETER



SOLENOID

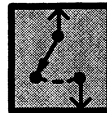

SWITCH

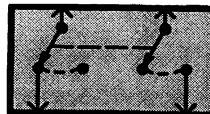

GANGED SWITCHES CONTACTS MOVE AT THE SAME TIME



DIODES CURRENT FLOWS IN DIRECTION OF ARROW ONLY



CAPACITOR



TRANSISTOR

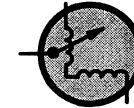

GAUGE



LIGHT EMITTING DIODE (LED)



LIGHT BULB

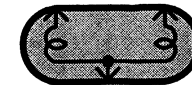

DUAL FILAMENT LIGHT BULB

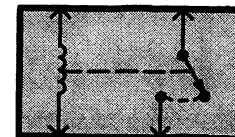

RELAY CONTACTS CHANGE POSITION WITH CURRENT THROUGH COIL

100% SATISFACTION GUARANTEED

BUY IT NOW!

Click Here To Order

10-1 GROUNDS

1999 F-150/250

All Circuit are 57 BK unless otherwise noted.

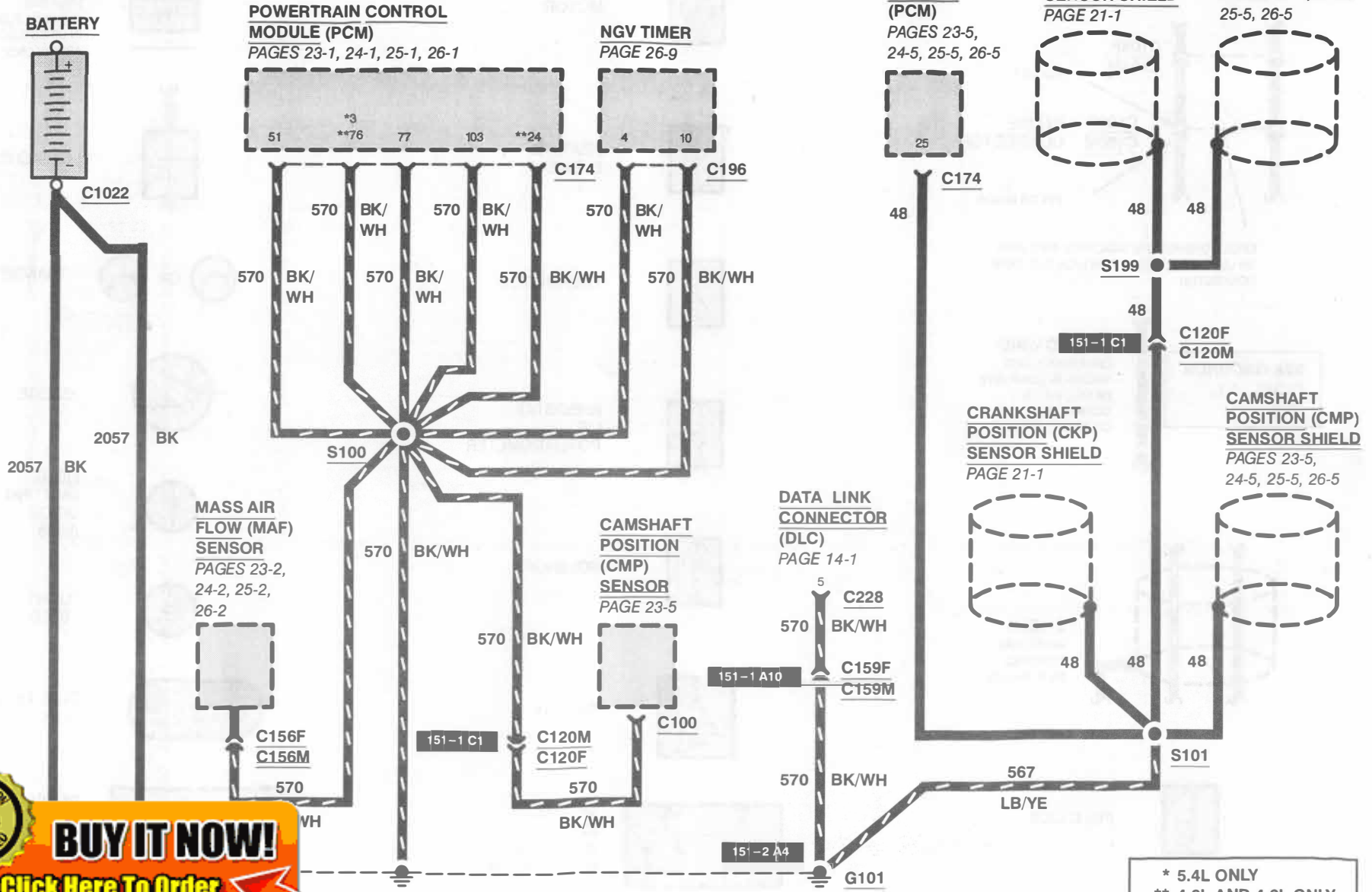

100% SATISFACTION GUARANTEED

BUY IT NOW!

Click Here To Order

PayPal, American Express, Discover, MasterCard, VISA

* 5.4L ONLY
 ** 4.2L AND 4.6L ONLY

All Circuit are 57 BK
unless otherwise noted.

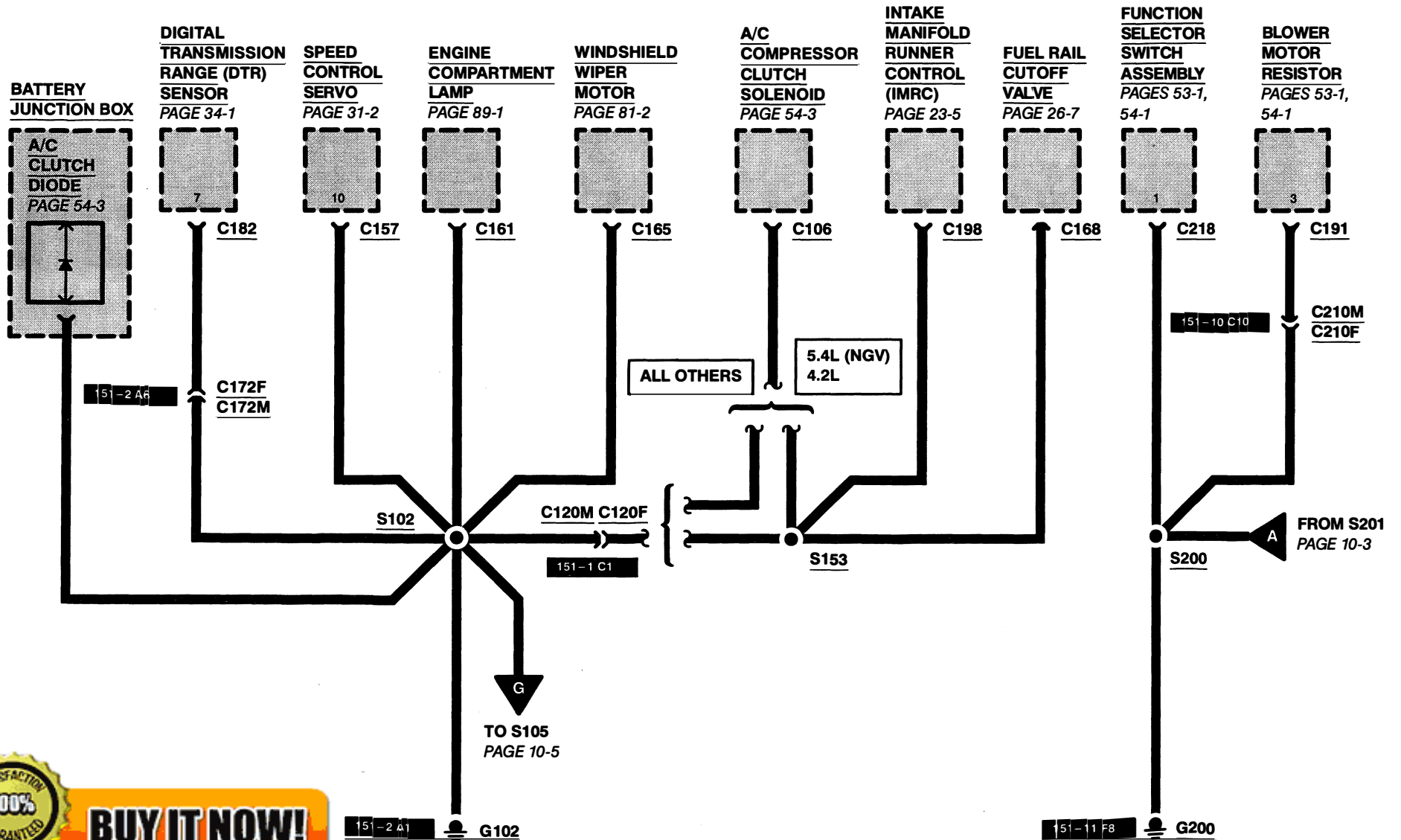

100% SATISFACTION GUARANTEED

BUY IT NOW!

Click Here To Order

PayPal, American Express, Discover, MasterCard, VISA

10-3 GROUNDS

1999 F-150/250

All Circuit are 57 BK
unless otherwise noted.

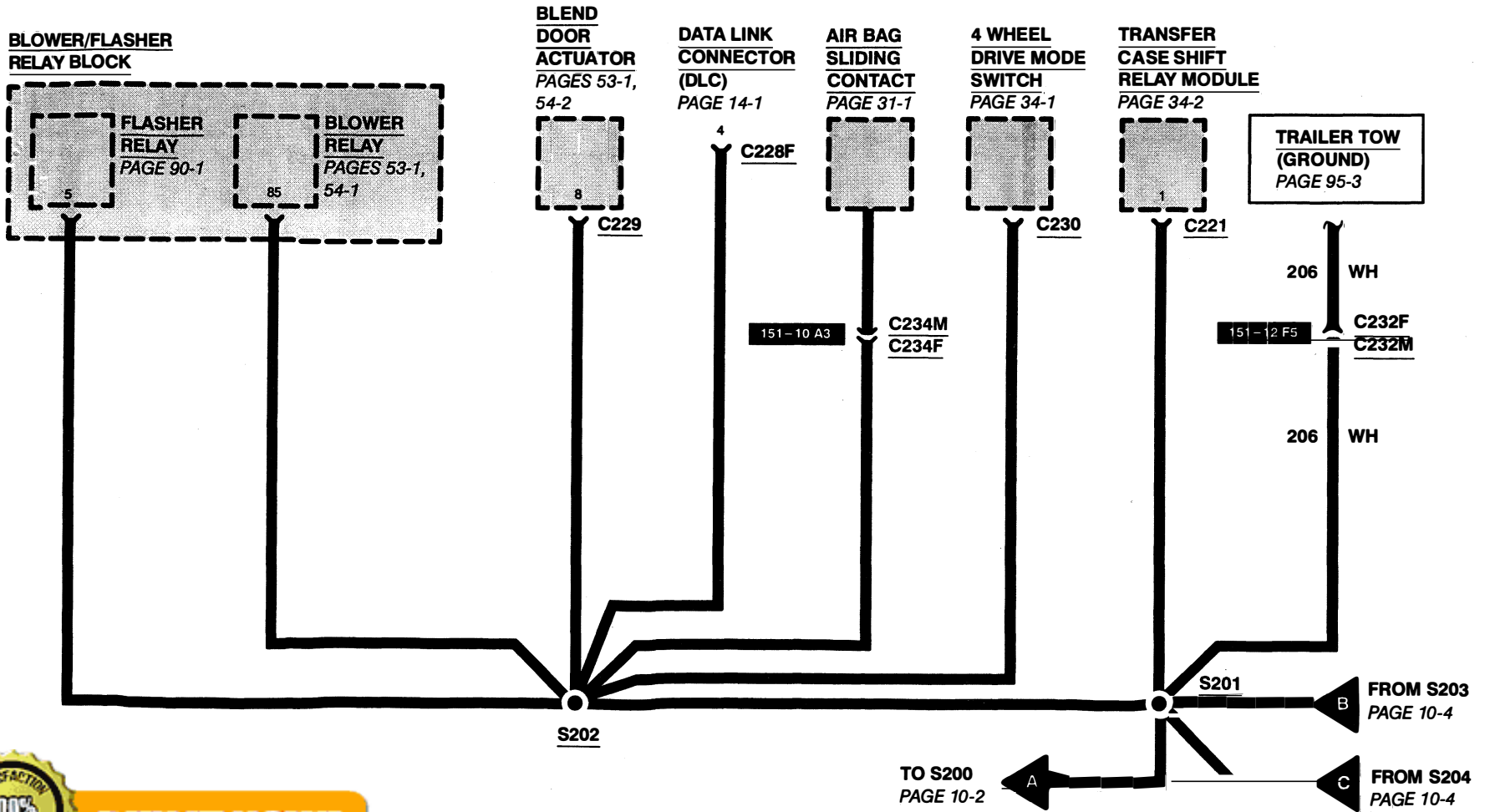

100% SATISFACTION GUARANTEED

BUY IT NOW!

Click Here To Order

PayPal Discover AMEX MasterCard VISA

All Circuit are 57 BK unless otherwise noted.

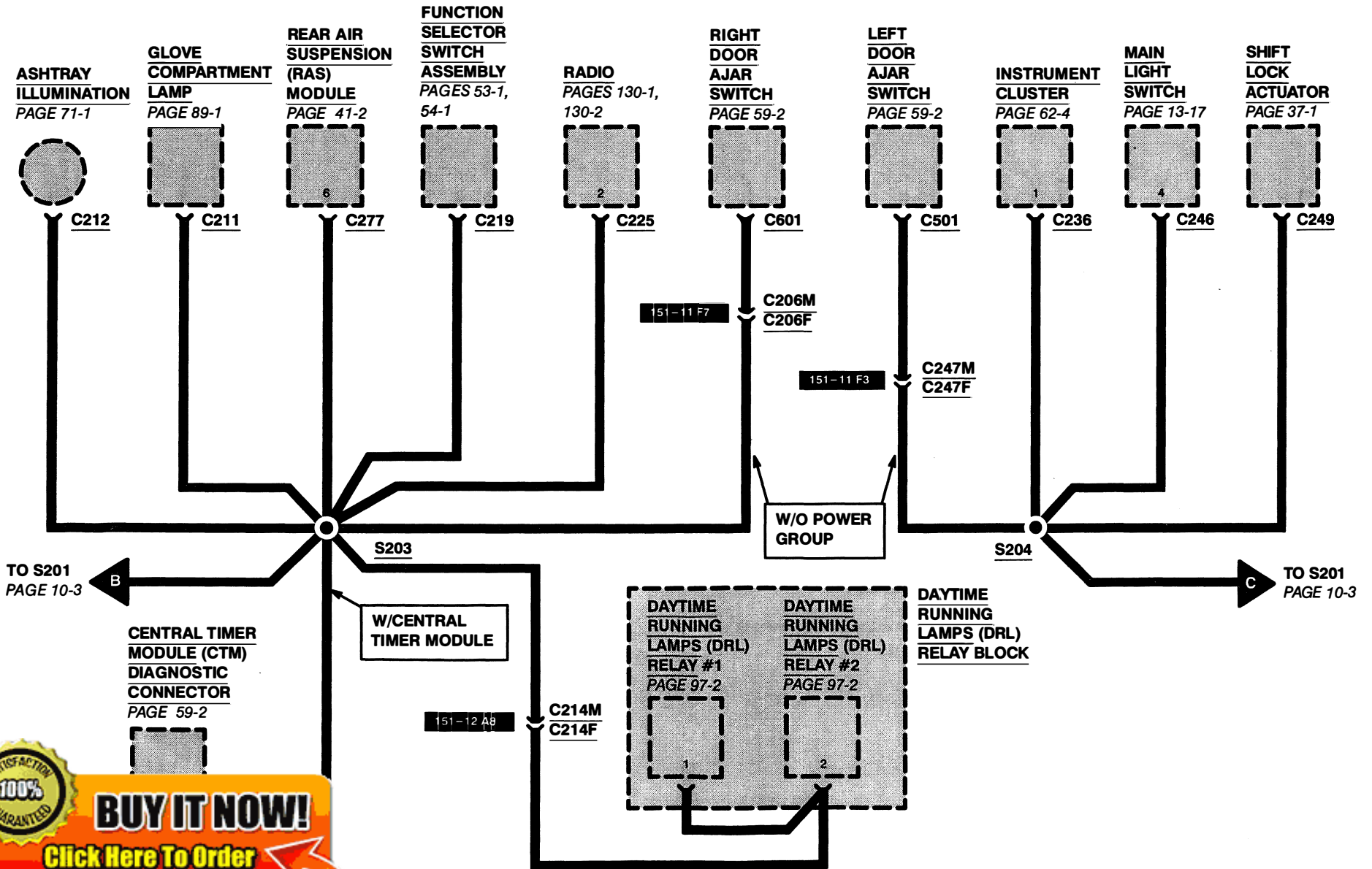

100% SATISFACTION GUARANTEED

BUY IT NOW!

Click Here To Order

PayPal Discover American Express MasterCard VISA

10-5 GROUNDS

1999 F-150/250

All Circuit are 57 BK unless otherwise noted.

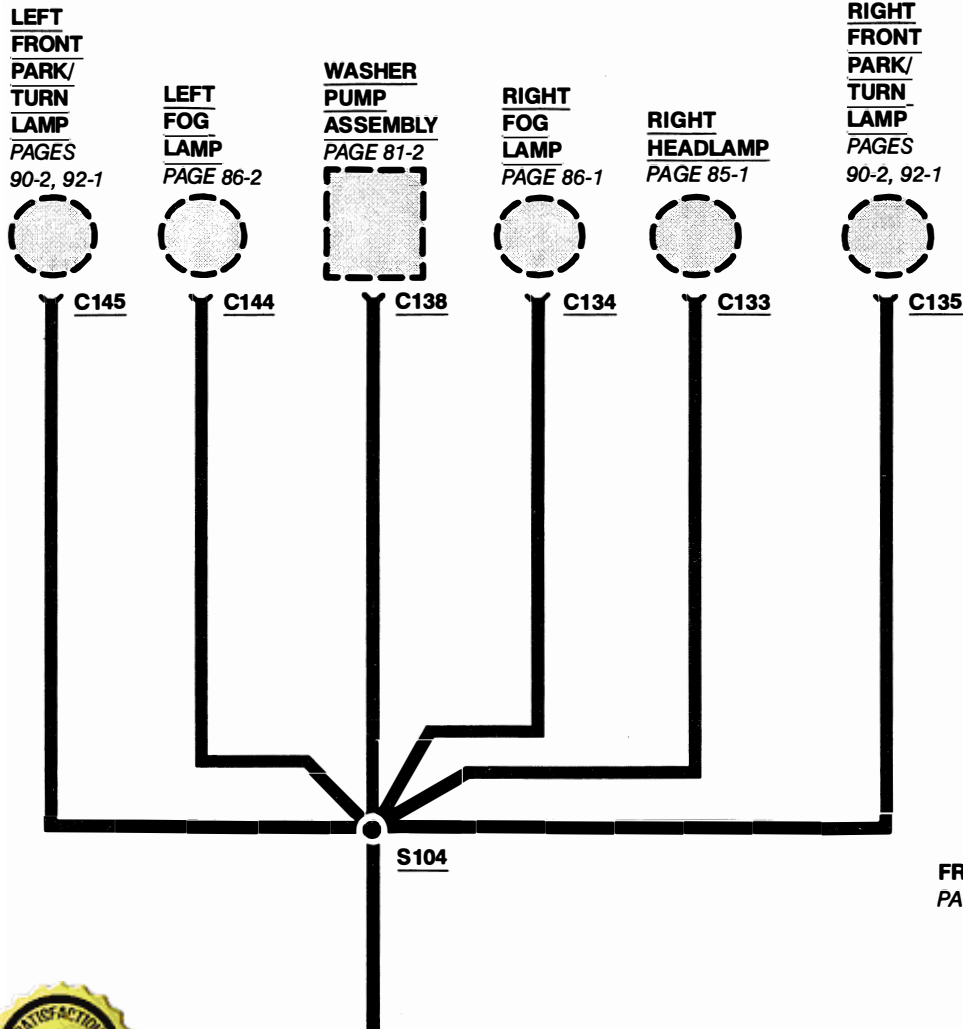

BATTERY JUNCTION BOX

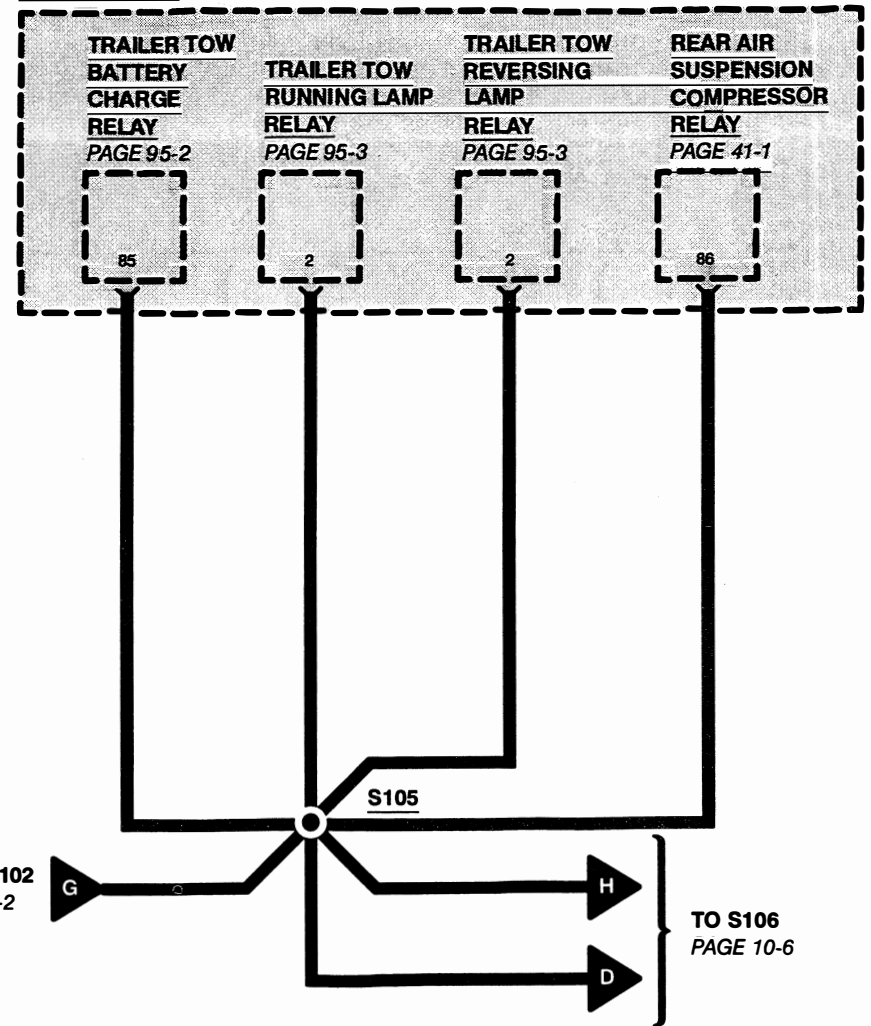

100% SATISFACTION GUARANTEED

BUY IT NOW!

Click Here To Order

All Circuit are 57 BK unless otherwise noted.

REAR ANTI-LOCK BRAKE SYSTEM (RABS) PROPORTIONING VALVE SWITCH ASSEMBLY
PAGE 42-2

4 WHEEL ANTI-LOCK BRAKE SYSTEM (4WABS) MODULE
PAGE 42-4

BRAKE FLUID LEVEL INDICATOR SWITCH
PAGES 42-1, 42-4

LEFT HEADLAMP
PAGE 85-1

FUEL PUMP ASSEMBLY
PAGES 23-7, 24-7, 25-7

LEFT STOP/PARK/TURN LAMP
PAGES 90-2, 92-2

RIGHT STOP/PARK/TURN LAMP
PAGES 90-2, 92-2

LEFT REVERSING LAMP
PAGE 93-1

RIGHT REVERSING LAMP
PAGE 93-1

LEFT TAIL/SIDE LAMP
PAGE 92-2

RIGHT TAIL/SIDE LAMP
PAGE 92-2

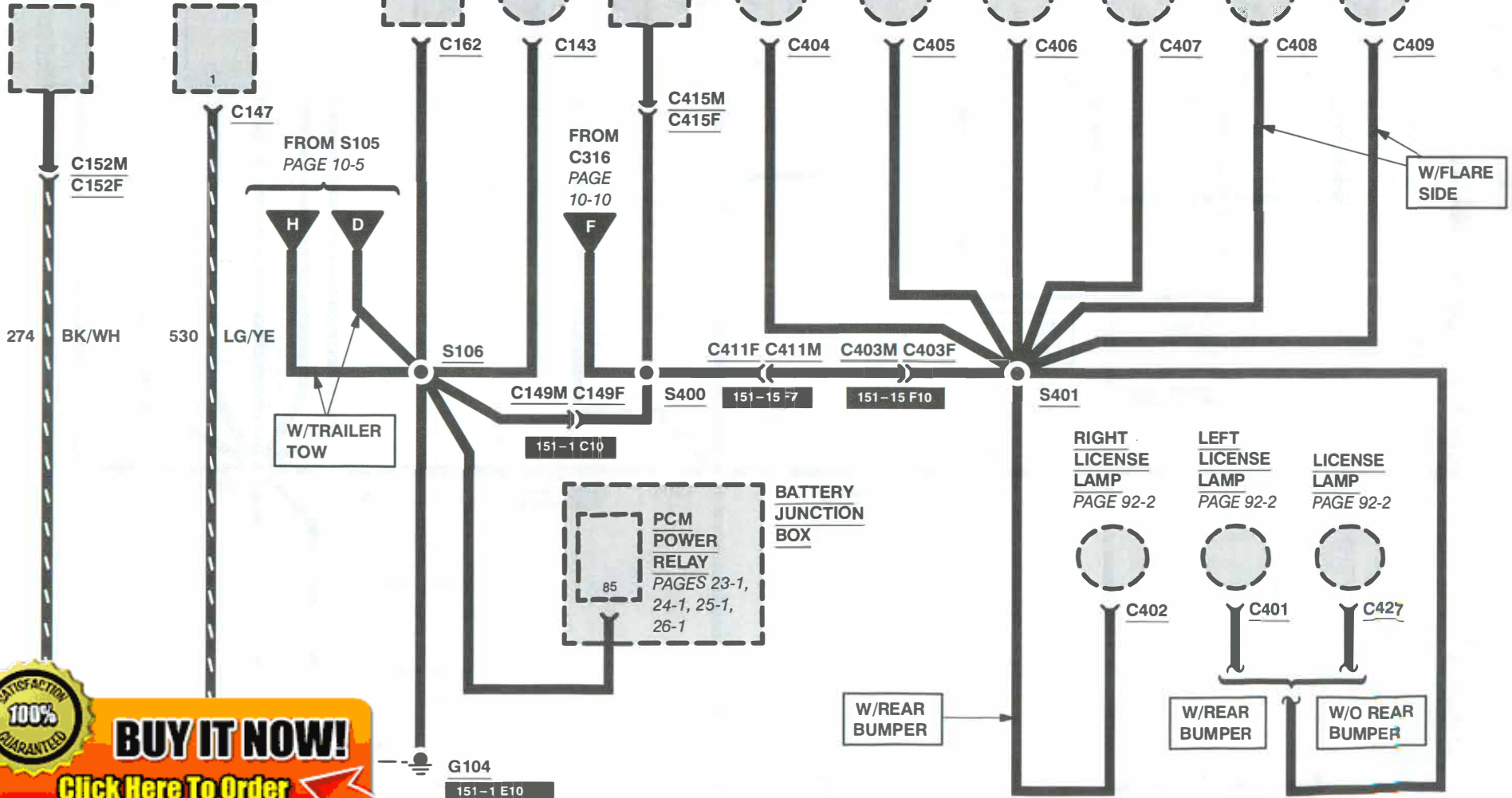

100% SATISFACTION GUARANTEED

BUY IT NOW!

Click Here To Order

10-7 GROUNDS

1999 F-150/250

All Circuit are 57 BK unless otherwise noted.

* W/REMOTE ANTI-THEFT PERSONALITY (RAP) MODULE
 ** W/O REMOTE ANTI-THEFT PERSONALITY (RAP) MODULE

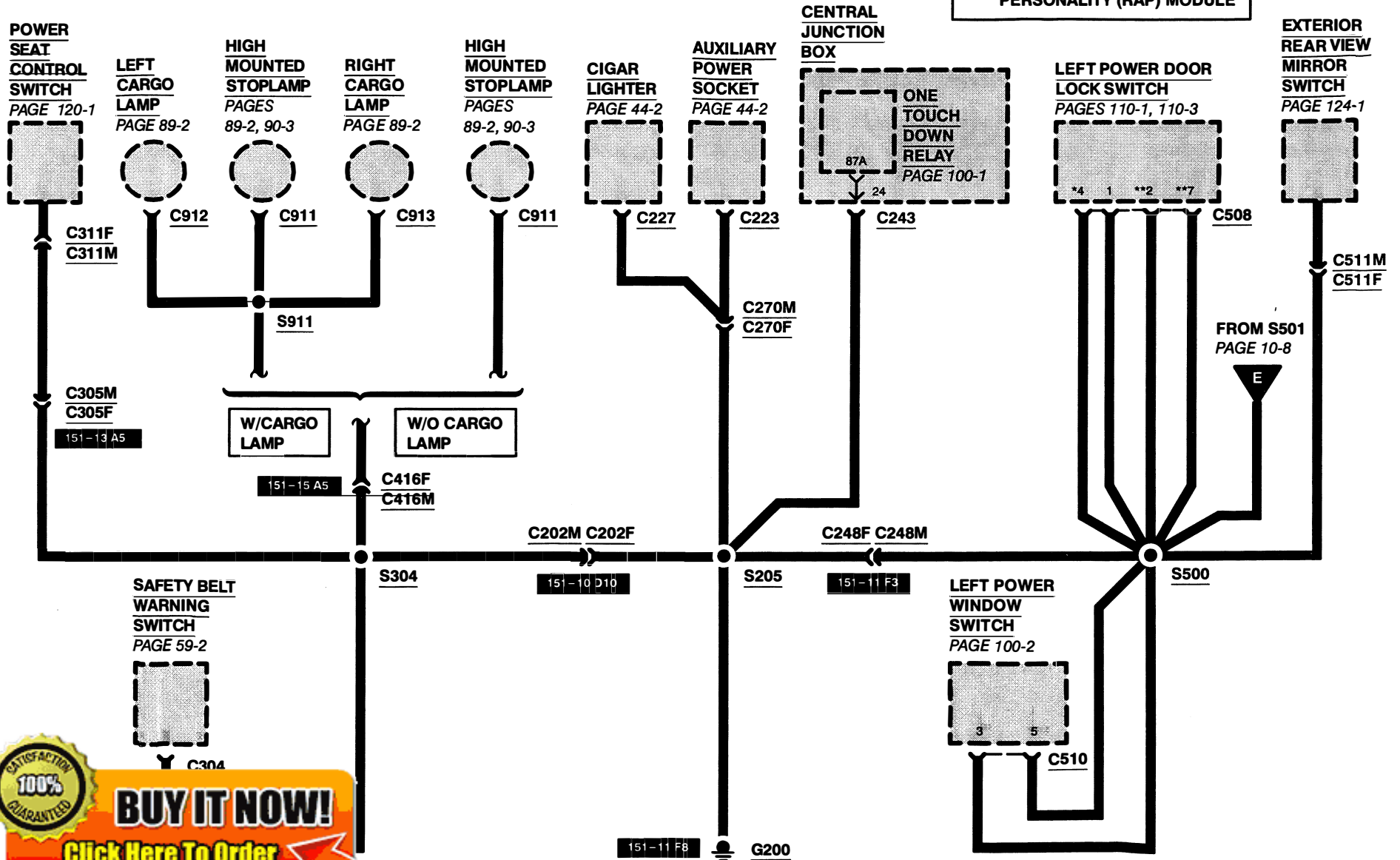

100% SATISFACTION GUARANTEED

BUY IT NOW!

Click Here To Order

* W/REMOTE ANTI-THEFT
PERSONALITY (RAP) MODULE

All Circuit are 57 BK
unless otherwise noted.

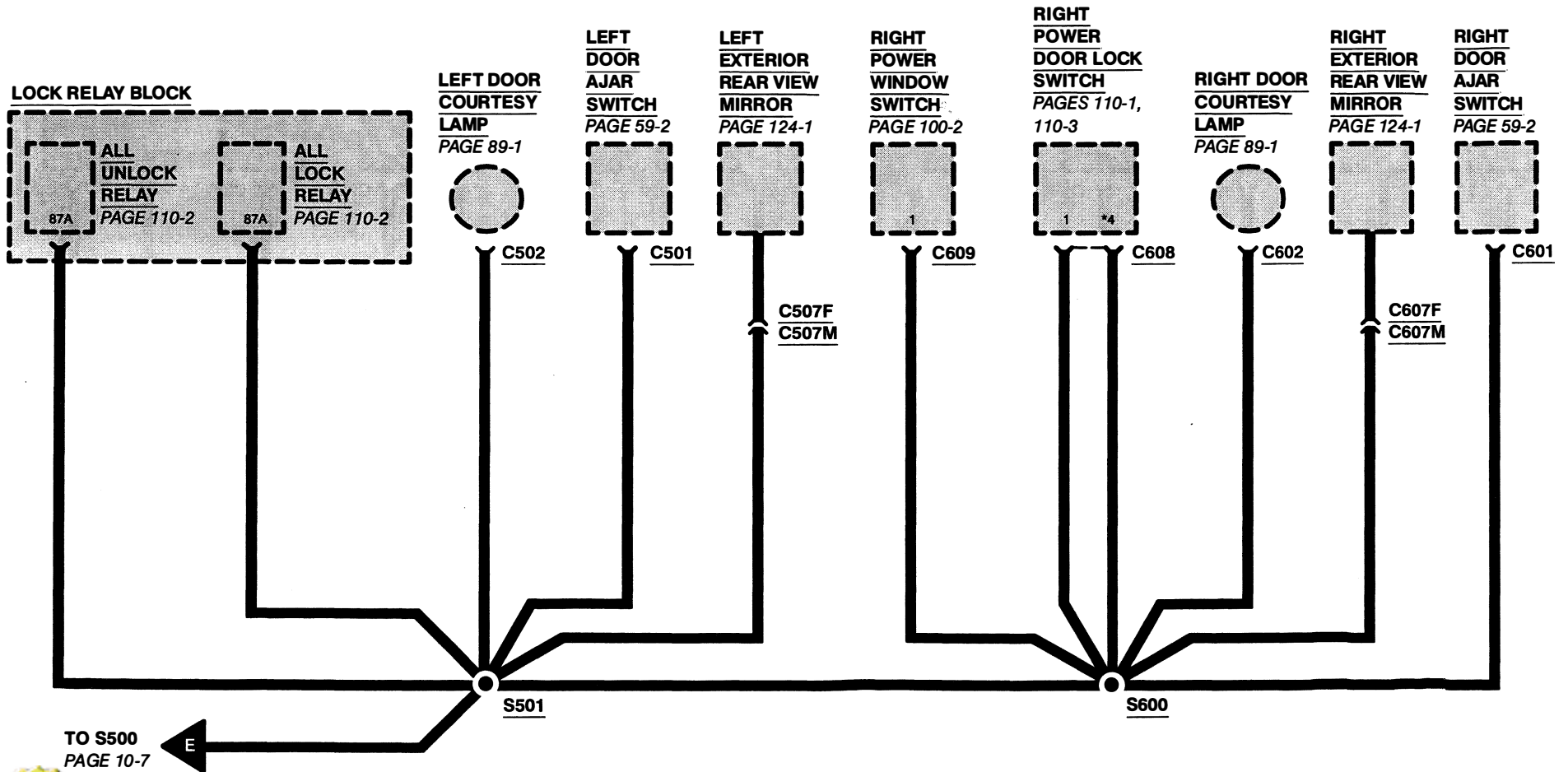

100% SATISFACTION GUARANTEED

BUY IT NOW!

Click Here To Order

PayPal, American Express, Discover, MasterCard, VISA

10-9 GROUNDS

1999 F-150/250

All Circuit are 57 BK unless otherwise noted.

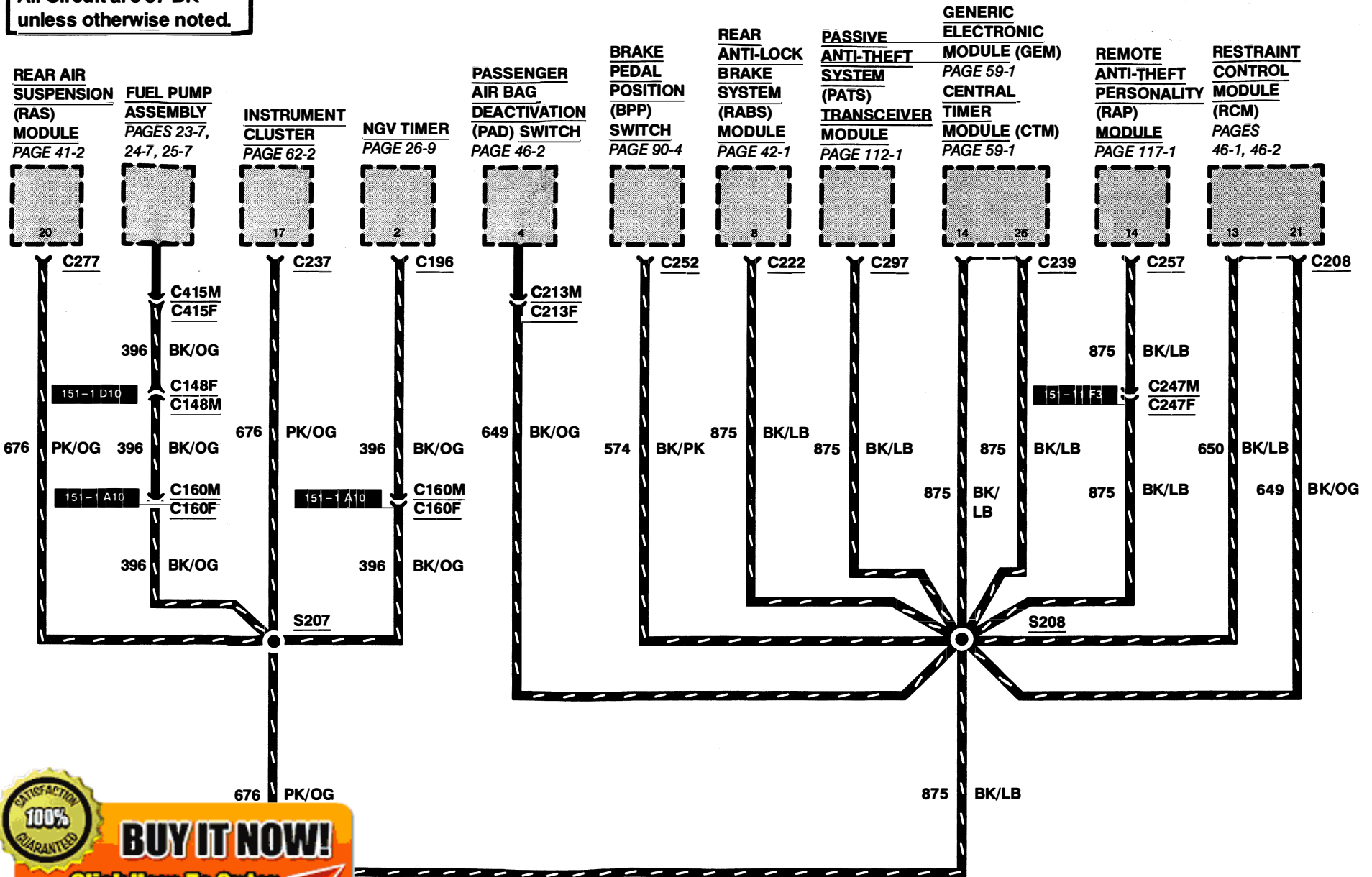

100% SATISFACTION GUARANTEED

BUY IT NOW!

Click Here To Order

All Circuit are 57 BK unless otherwise noted.

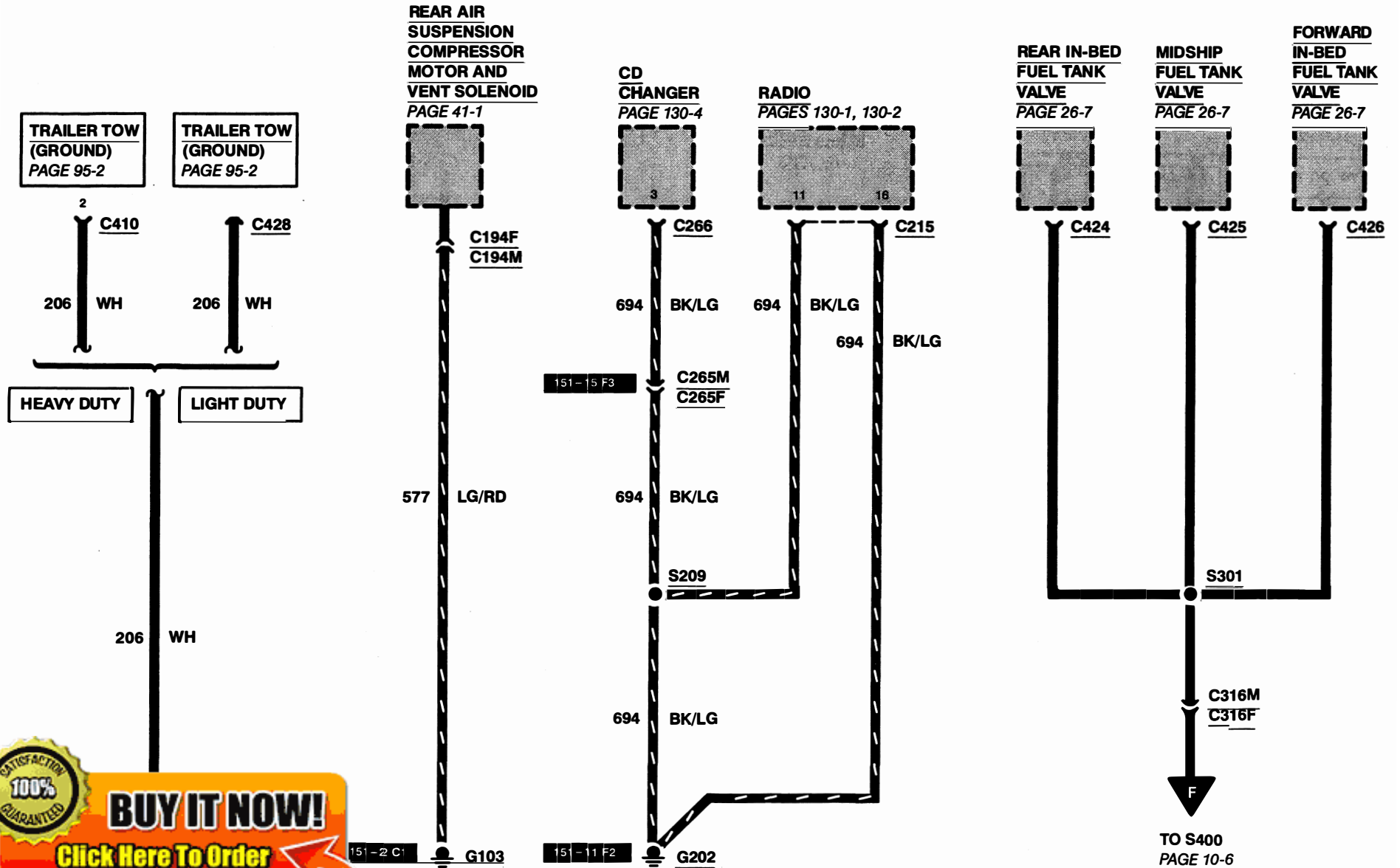

100% SATISFACTION GUARANTEED

BUY IT NOW!

Click Here To Order

11-1 FUSE PANEL/CIRCUIT PROTECTION

1999 F-150/250

CIRCUIT PROTECTION DEVICES

Electrical circuits on this vehicle may be protected by fuses, fusible links, maxi-fuses, circuit breakers, or a combination of these devices.

BLADE TYPE FUSE

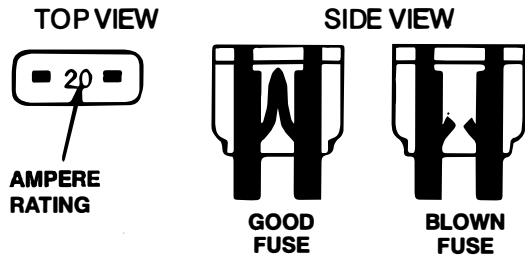

Blade type fuses have a transparent plastic housing. To check a fuse, pull it from the fuse panel and look at the fuse element through the housing. Always replace a blown fuse with a new fuse that has the same ampere rating.

The ampere rating of a blade type fuse can also be determined by following the color code shown here:

BLADE FUSE COLOR CODING	
AMPERE RATING	HOUSING COLOR
4	Pink
5	Tan
10	Red
15	Blue
20	Yellow

100% SATISFACTION GUARANTEED

BUY IT NOW!

Click Here To Order

MAXI-FUSE

TOP VIEW

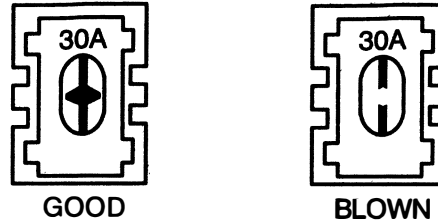

Cartridge maxi-fuses have transparent plastic tops. To check a cartridge maxi-fuse, look at the fuse element through the top of the housing.

To replace a cartridge maxi-fuse, pull it from the fuse box or panel. Always replace a blown cartridge maxi-fuse with a new one having the same ampere rating.

The ampere rating of a cartridge maxi-fuse can also be determined by following the color code shown here:

CARTRIDGE TYPE FUSIBLE LINKS		
High Current Fuse Value Amps		Color Code
20A	Cartridge	Blue
30A	Cartridge	Pink
40A	Cartridge	Green
50A	Cartridge	Red

CIRCUIT BREAKER

Some circuits are protected by circuit breakers (abbreviated "c. b." in fuse chart). They can be Fuse Panel mounted or in-line. Like fuses, they are rated in amperes.

Each circuit breaker conducts current through an arm made of two types of metal bonded together (bimetal arm). If the arm starts to carry too much current, it heats up. As one metal expands faster than the other the arm bends, opening the contacts. Current flow is broken. A circuit breaker can be the cycling or non-cycling type.

FUSE PANEL MOUNTED CYCLING TYPE

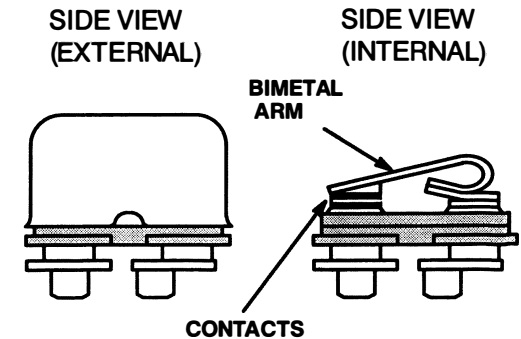

IN-LINE MOUNTED CYCLING TYPE

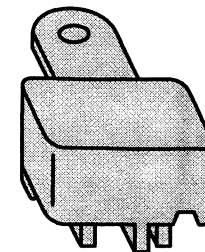

IN-LINE CONNECTOR FACES 150-8

1999 F-150/250

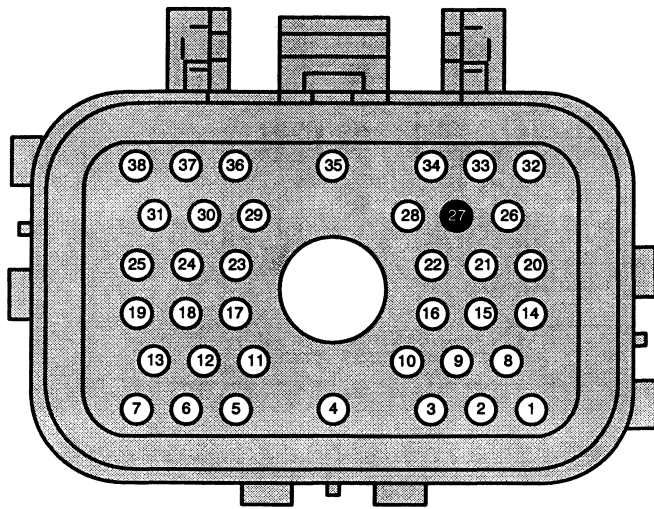

C172F

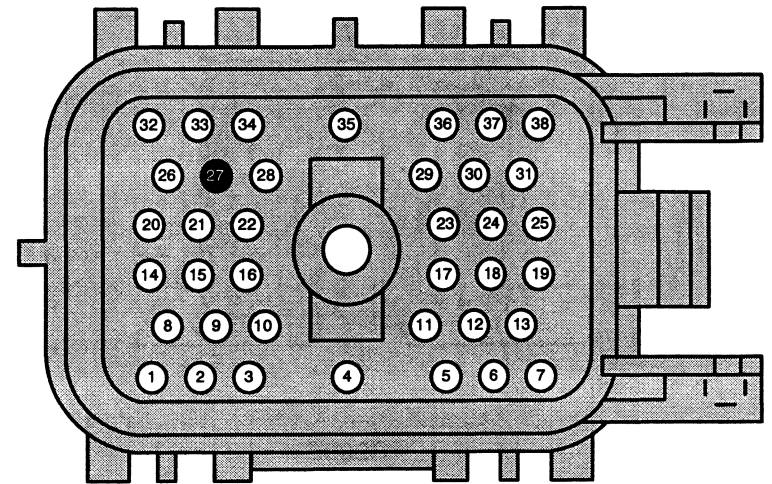

C172M

PIN	CIRCUIT	PIN	CIRCUIT	PIN	CIRCUIT
1	1093 (TN/RD)	13	1145 (LB/BK)	26	463 (RD/WH)
2	*1093 (TN/RD)	14	359 (GY/RD)	27	—
	**325 (DB/OG)	15	389 (WH/BK)	28	57 (BK)
3	1138 (VT/WH)	16	390 (TN/YE)	29	923 (OG/BK)
4	924 (RD/OG)	17	392 (RD/LG)	30	74 (GY/LB)
5	779 (BN)	18	393 (VT/LG)	31	94 (RD/BK)
6	387 (RD/WH)	19	1497 (PK/BK)	32	140 (BK/PK)
7	388 (YE/LB)	20	1496 (PK)	33	237 (DG/YE)
8	1202 (YE/LG)	21	783 (GY)	34	295 (LB/PK)
9	136 (DB/YE)	22	784 (LB/BK)	35	315 (VT/OG)
10	1144 (YE/BK)	23	971 (PK/BK)	36	480 (VT/YE)
	199 (LB/YE)	24	970 (DG/WH)	37	925 (WH/YE)
			(WH/BK)	38	391 (RD/YE)

PIN	CIRCUIT	PIN	CIRCUIT	PIN	CIRCUIT
1	1093 (TN/RD)	14	359 (GY/RD)	27	—
2	325 (DB/OG)	15	389 (WH/BK)	28	57 (BK)
3	1138 (VT/WH)	16	390 (TN/YE)	29	923 (OG/BK)
4	924 (RD/OG)	17	392 (RD/LG)	30	74 (GY/LB)
5	779 (BN)	18	393 (VT/LG)	31	94 (RD/BK)
6	387 (RD/WH)	19	1497 (PK/BK)	32	140 (BK/PK)
7	388 (YE/LB)	20	1496 (PK)	33	237 (DG/YE)
8	1202 (YE/LG)	21	783 (GY)	34	295 (LB/PK)
9	136 (DB/YE)	22	784 (LB/BK)	35	315 (VT/OG)
10	1144 (YE/BK)	23	971 (PK/BK)	36	480 (VT/YE)
11	1000 (RD/BK)	24	970 (DG/WH)	37	925 (WH/YE)
12	199 (LB/YE)	25	1143 (WH/BK)	38	391 (RD/YE)
13	1145 (LB/BK)	26	463 (RD/WH)		

100% SATISFACTION GUARANTEED

BUY IT NOW!

Click Here To Order

150-9 IN-LINE CONNECTOR FACES

1999 F-150/250

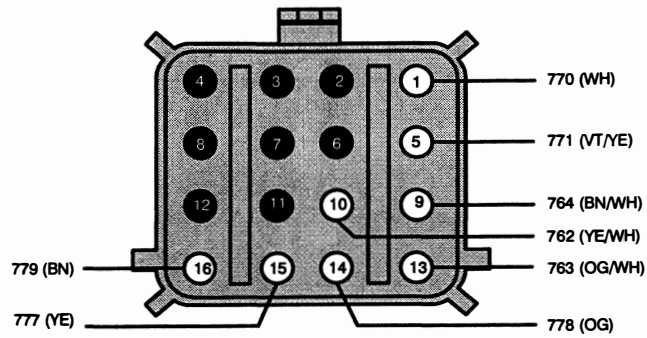

C200F

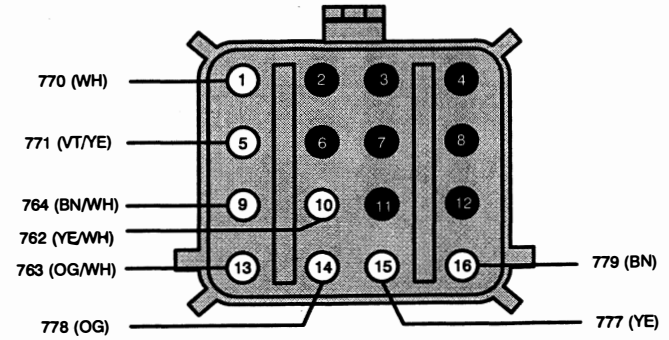

C200M

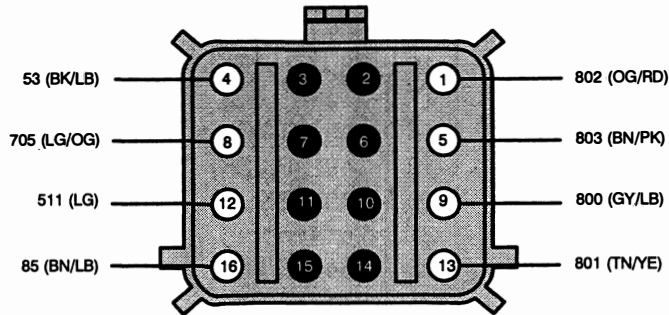

C203F

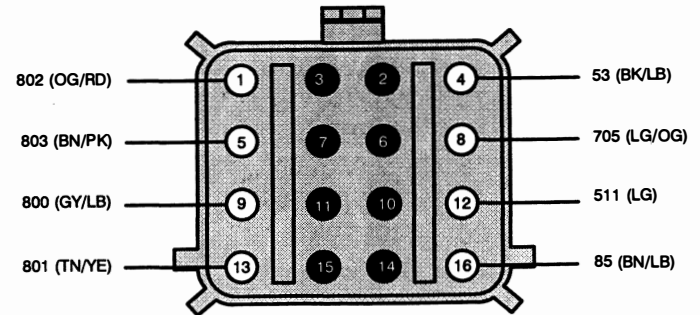

C203M

100% SATISFACTION GUARANTEED

BUY IT NOW!

[Click Here To Order](#)

IN-LINE CONNECTOR FACES 150-10

1999 F-150/250

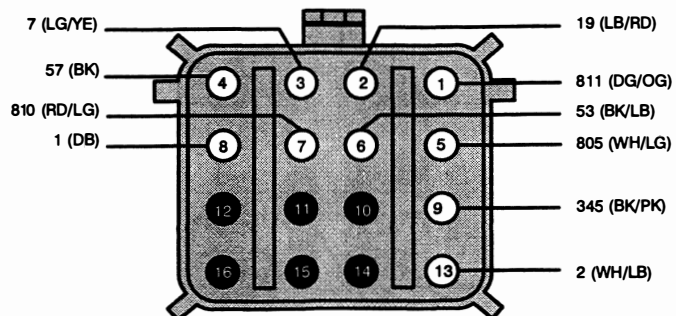

C206F

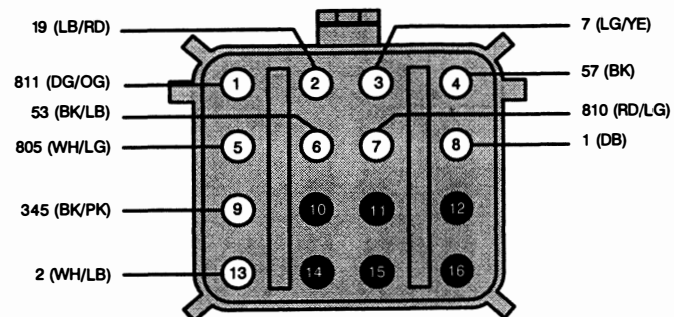

C206M

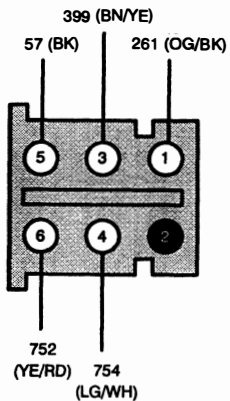

C210F

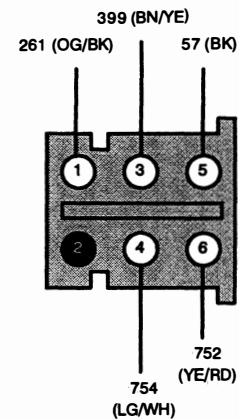

C210M

100% SATISFACTION GUARANTEED

BUY IT NOW!

Click Here To Order

150-11 IN-LINE CONNECTOR FACES

1999 F-150/250

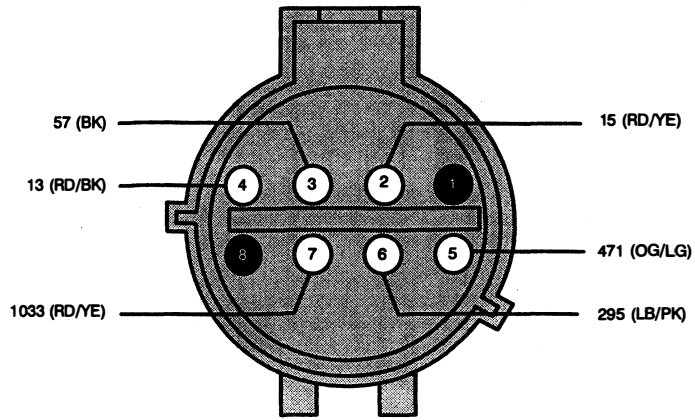

C214F

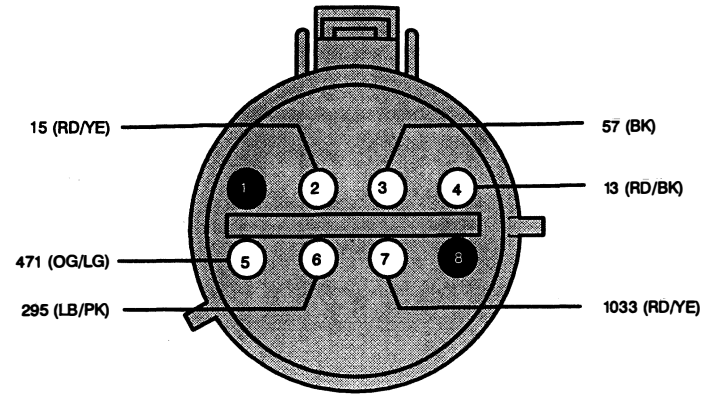

C214M

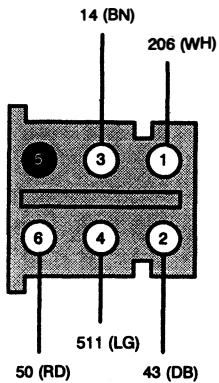

C232F

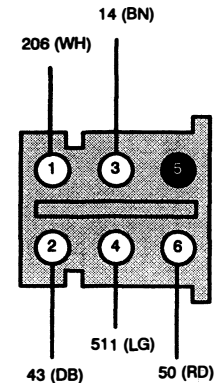

C232M

100% SATISFACTION GUARANTEED

BUY IT NOW!

[Click Here To Order](#)

IN-LINE CONNECTOR FACES 150-12

1999 F-150/250

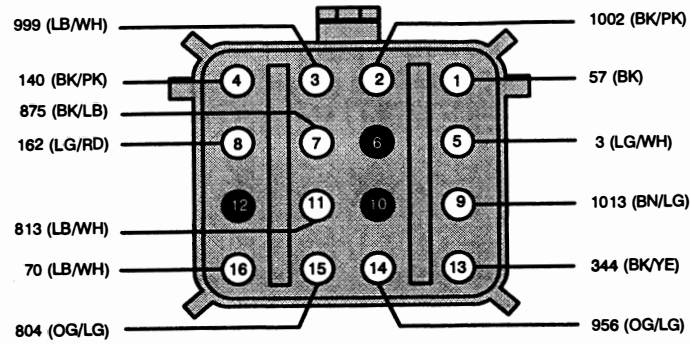

C247F

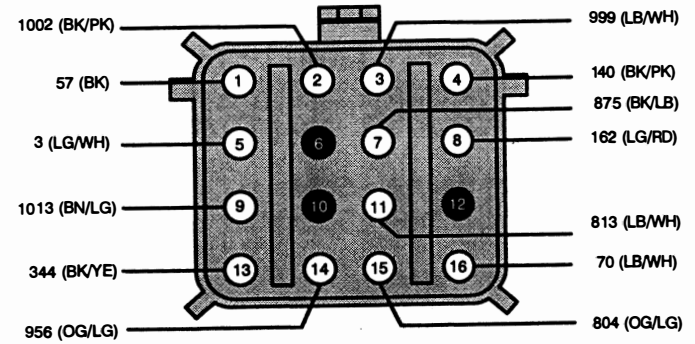

C247M

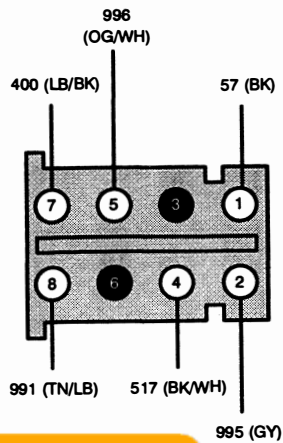

C248F

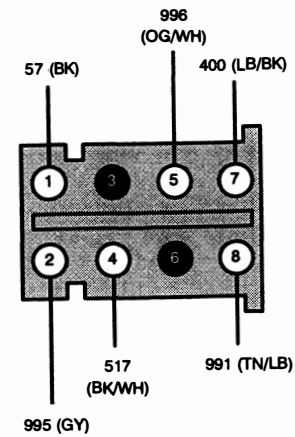

C248M

100% SATISFACTION GUARANTEED

BUY IT NOW!

Click Here To Order

150-13 IN-LINE CONNECTOR FACES

1999 F-150/250

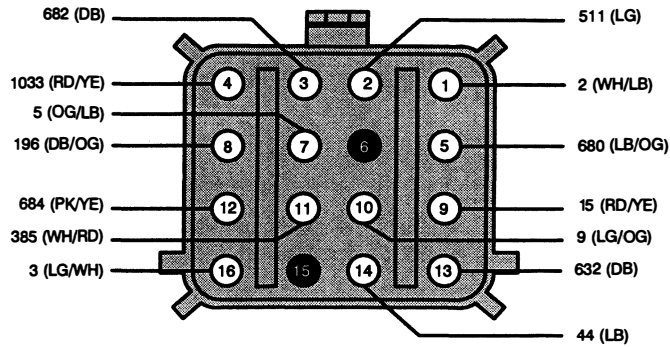

C253F

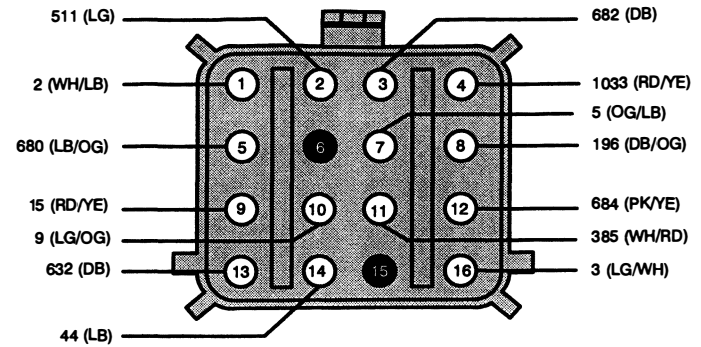

C253M

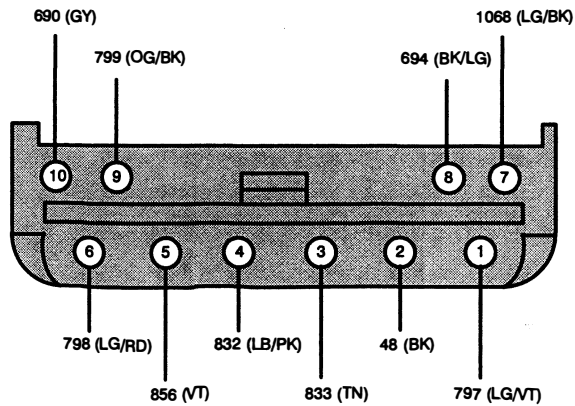

C255F

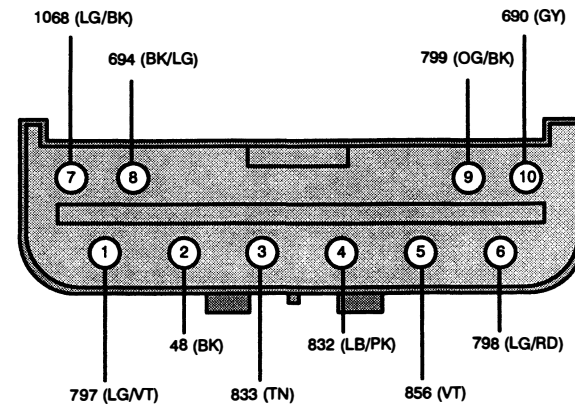

C265M

100% SATISFACTION GUARANTEED

BUY IT NOW!

[Click Here To Order](#)

PayPal, American Express, Discover, MasterCard, VISA

IN-LINE CONNECTOR FACES 150-14

1999 E-150/250

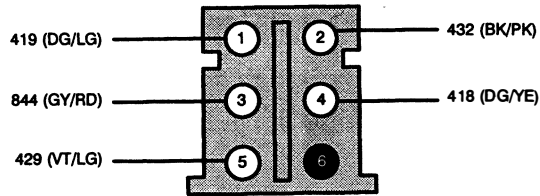

C278F

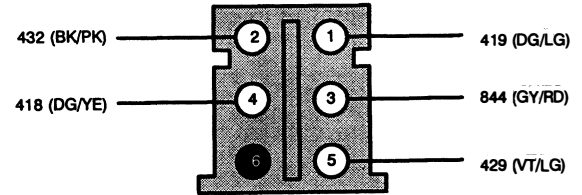

C278M

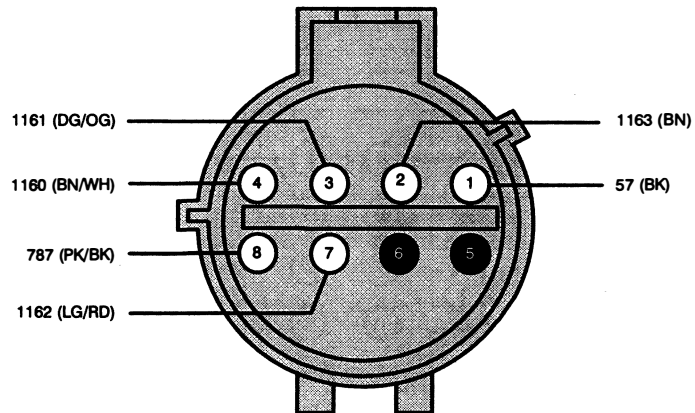

C316F

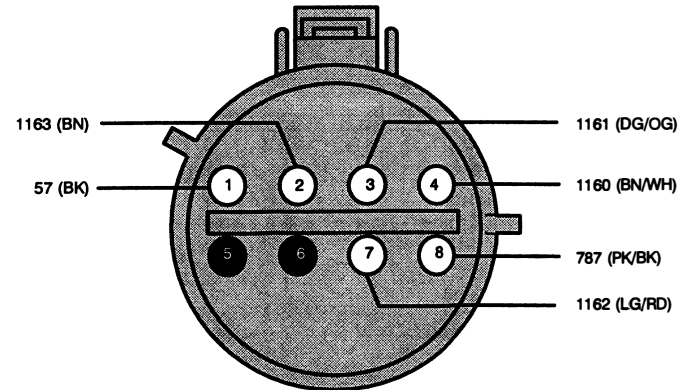

C316M

100% SATISFACTION GUARANTEED

BUY IT NOW!

[Click Here To Order](#)

PayPal, American Express, Discover, MasterCard, VISA

150-15 IN-LINE CONNECTOR FACES

1999 F-150/250

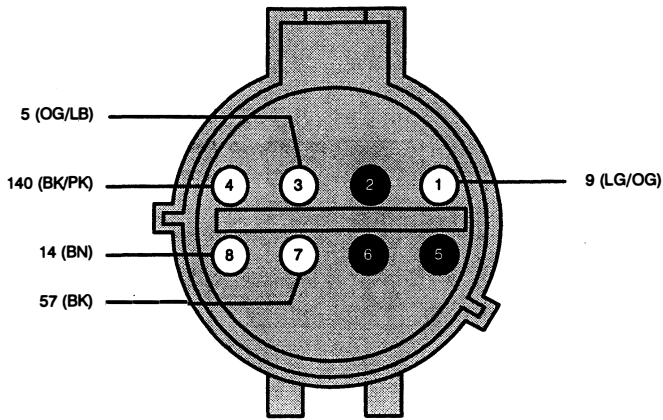

C403F

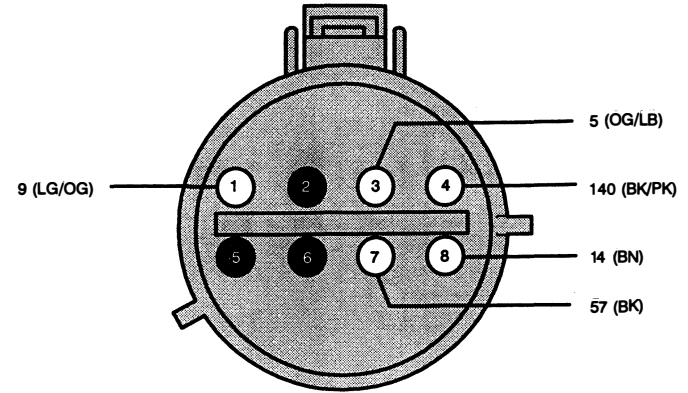

C403M

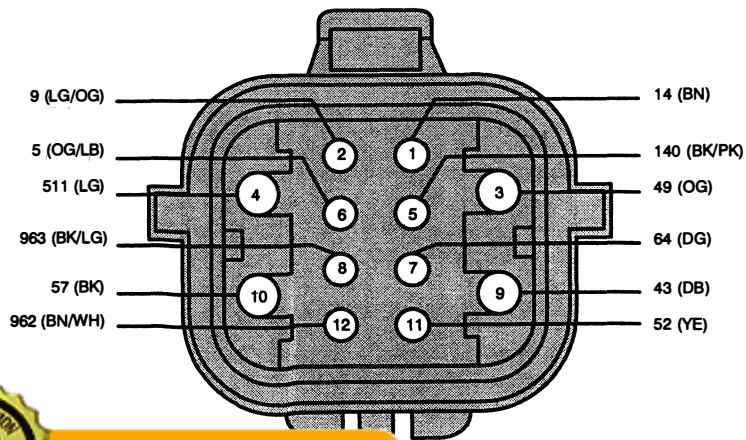

C411F

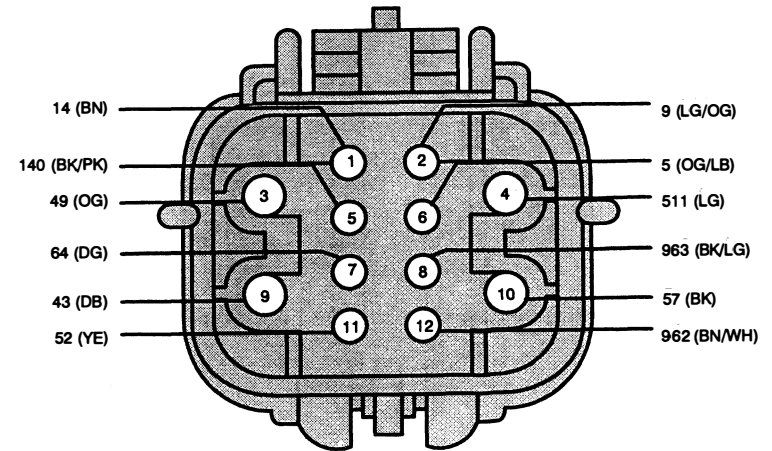

C411M

100% SATISFACTION GUARANTEED

BUY IT NOW!

Click Here To Order

151-1 COMPONENT LOCATION VIEWS

1999 F-150/250

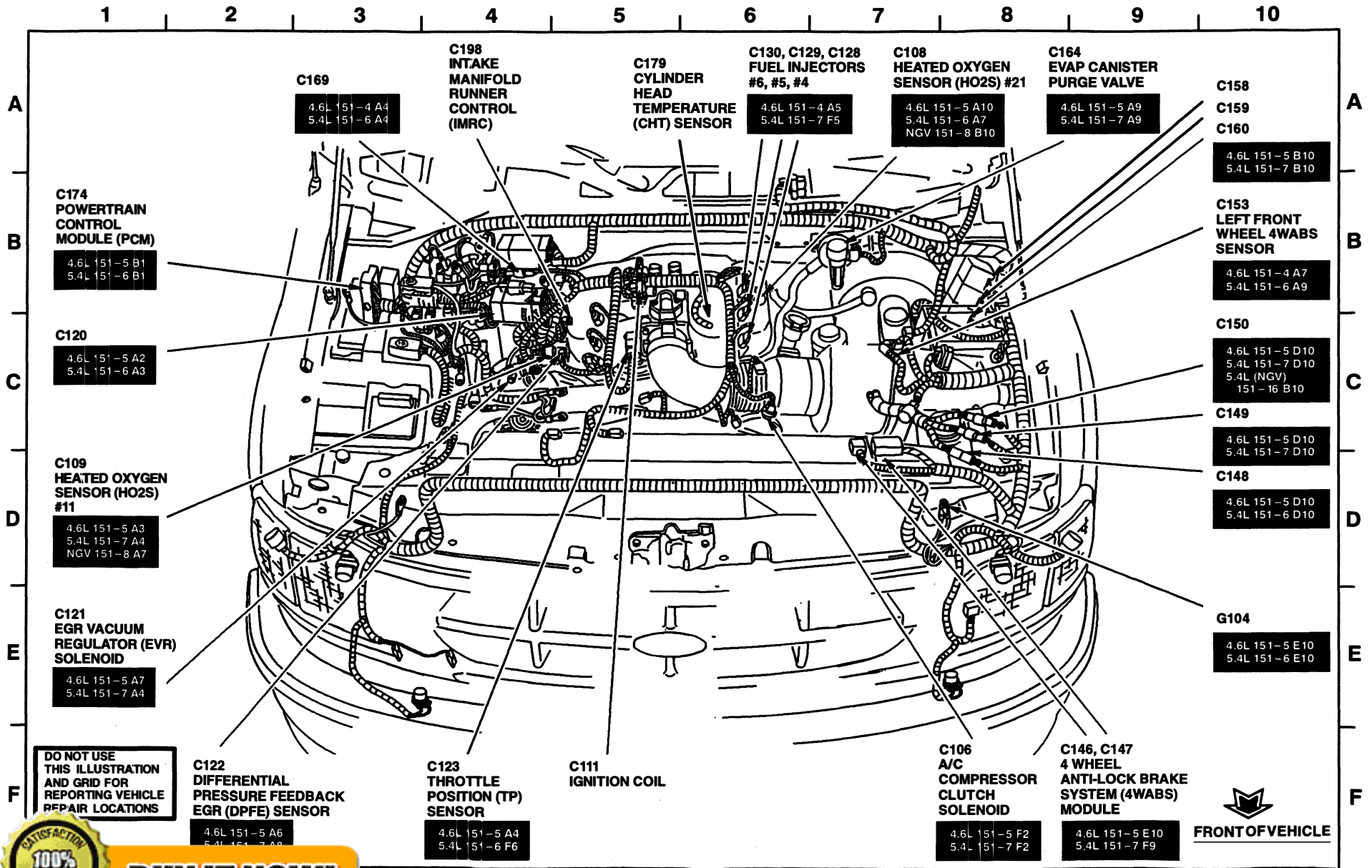

4.2L ENGINE (1 OF 3)

100% SATISFACTION GUARANTEED

BUY IT NOW!

[Click Here To Order](#)

COMPONENT LOCATION VIEWS 151-2

1999 F-150/250

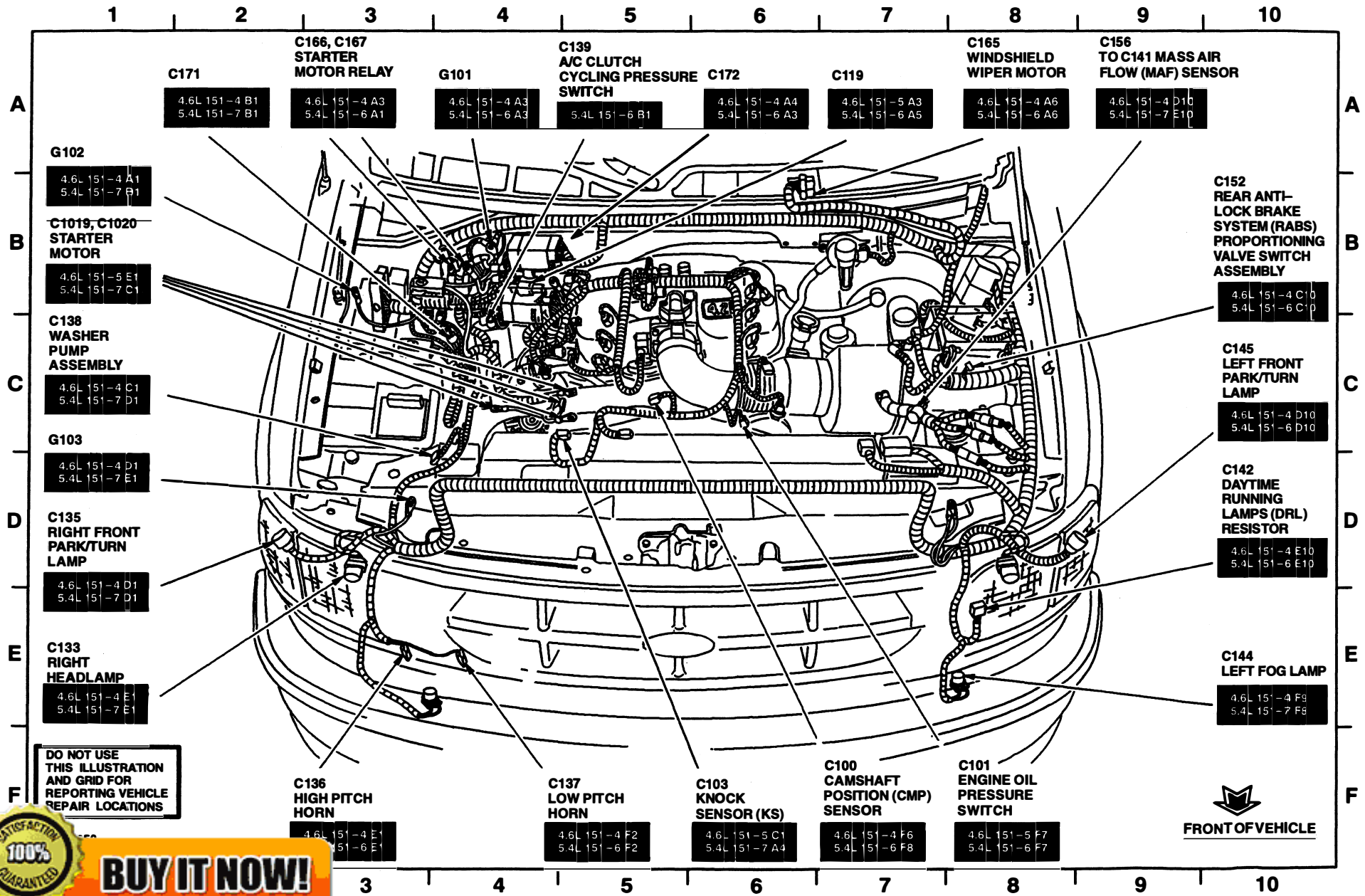

4.2L ENGINE (2 OF 3)

100% SATISFACTION GUARANTEED

BUY IT NOW!

[Click Here To Order](#)



**TECHNICAL
SUPPORT OPERATIONS**

Ford Customer Service Division



FCS-12263-99

JUNE 1998

LITHO IN U.S.A.
AD-328

**COPYRIGHT © 1998
FORD MOTOR COMPANY**