

Click Here To Order

BUY IT NOW!

Buy Now

VISA MASTERCARD DISCOVER AMERICAN EXPRESS BANK

DEMO contains only a few pages of the entire manual/product.

Not all Bookmarks work on the Demo, but they do on the full version.

Features:

- Searchable text
- Printable pages
- Bookmarked for easy navigation
- High Resolution images
- Zoom to see exact details
- Money back Guarantee
- Available on USB and eBook download

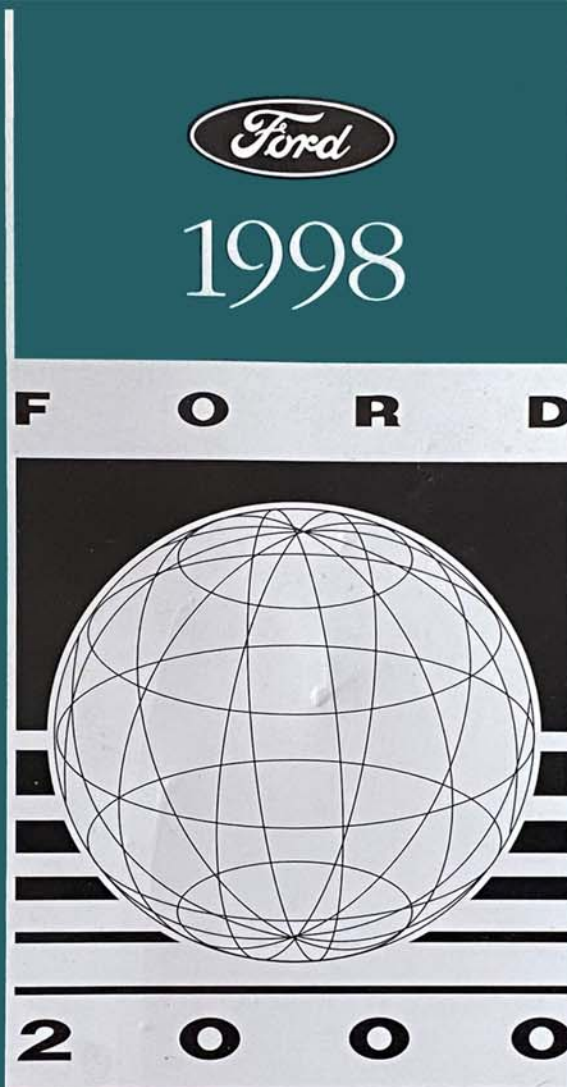

MUSTANG



License #84356800

ELECTRICAL VACUUM AND TROUBLESHOOTING MANUAL

Copyright © 2024, Forel Publishing Company, LLC, Woodbridge, Virginia

All Rights Reserved. No part of this book may be used or reproduced in any manner whatsoever without written permission of Forel Publishing Company, LLC. For information write to Forel Publishing Company, LLC, Woodbridge, VA 22192

**1998 Mustang Electrical and Vacuum
Trouble-Shooting Manual (EVTM)
EAN: 978-1-60371-433-4
ISBN: 1-60371-433-2**

Forel Publishing Company, LLC
Woodbridge, VA 22192
Email: sales@ForelPublishing.com
<https://www.ForelPublishing.com>



This publication contains material that is reproduced and distributed under a license from Ford Motor Company. No further reproduction or distribution of the Ford Motor Company material is allowed without the express written permission of Ford Motor Company.

Note from the Publisher

This product was created from the original Ford Motor Company's publication. Every effort has been made to use the original scanned images, however, due to the condition of the material; some pages have been modified to remove imperfections.

Disclaimer

Although every effort was made to ensure the accuracy of this book, no representations or warranties of any kind are made concerning the accuracy, completeness or suitability of the information, either expressed or implied. As a result, the information contained within this book should be used as general information only. The author and Forel Publishing Company, LLC shall have neither liability nor responsibility to any person or entity with respect to any loss or damage caused, or alleged to be caused, directly or indirectly by the information contained in this book. Further, the publisher and author are not engaged in rendering legal or other professional services. If legal, mechanical, electrical, or other expert assistance is required, the professional should be sought.



We Want To Hear From You!

Your suggestions will help us to improve this manual.
Mail this form or fax your comments to (313) 390-8727

Date: _____

- Publication:
- | | |
|-------------------------------------------------------|-----------------------------------------------|
| <input type="checkbox"/> Passenger Car Service Manual | <input type="checkbox"/> Truck Service Manual |
| <input type="checkbox"/> Owner Guide | <input type="checkbox"/> PC/ED Manual |
| <input type="checkbox"/> Wiring Diagram | <input type="checkbox"/> EVTM |
| <input type="checkbox"/> Body Repair Manual | |

Vehicle Line: _____ Year: _____

Please check which area the concern is located in the publication:

- | | |
|-------------------------------------------------------------|----------------------------------------------------|
| <input type="checkbox"/> Schematic(s) | <input type="checkbox"/> Disassembly and Assembly |
| <input type="checkbox"/> Pinpoint Test(s) | <input type="checkbox"/> Description and Operation |
| <input type="checkbox"/> Diagnostic(s) | <input type="checkbox"/> Cleaning and Operation |
| <input type="checkbox"/> Removal and Installation | <input type="checkbox"/> Specifications |
| <input type="checkbox"/> Special Service Tools
Equipment | <input type="checkbox"/> Adjustments |
| <input type="checkbox"/> Vehicle Application | |

Section and Page(s): _____

Explain concern in detail: *(Please Print)*

Please tell us who you are:
Company Name: *(Please Print)* _____
Street: _____
City: _____ State: _____ Zip/Postal Code: _____
Phone Number: _____

Occupation: *(Please mark box)*

- | | |
|-------------------------------------------------|------------------------------------------|
| <input type="checkbox"/> Ford Dealer Technician | <input type="checkbox"/> Service Manager |
| <input type="checkbox"/> Home Mechanic | <input type="checkbox"/> Engineer |
| <input type="checkbox"/> Non-Ford Technician | <input type="checkbox"/> Other: _____ |



BUY IT NOW!

Click Here To Order

Service Publication? Yes No

Improved?

Format and Style Other: _____



DO NOT STAPLE — USE TRANSPARENT TAPE



NO POSTAGE
NECESSARY
IF MAILED
IN THE
UNITED STATES

BUSINESS REPLY MAIL
FIRST CLASS PERMIT NO. 400 DEARBORN, MI

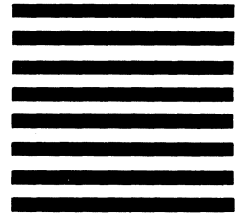

POSTAGE WILL BE PAID BY ADDRESSEE

Technical Service Publications
EVTM
P.O. Box 2592
Dearborn, MI 48121-9973



BUY IT NOW!

Click Here To Order



PayPal



ELECTRICAL AND VACUUM TROUBLESHOOTING MANUAL

FCS-12121-98

FORD CUSTOMER SERVICE DIVISION

Quality is Job 1

Ford Customer Service Division has developed a new format for the 1998 Mustang EVTm . Our goal is to provide accurate and timely electrical and vacuum service information.

1998 EVTm FEATURES

- Schematic pages now contain **Component Location** references to full-view illustrations and **Component Descriptions** that describe the system function of a component.
- "**COMPONENT TESTING**" procedures (CELL 149) that tell the user how to perform diagnostic tests on various circuits.
- **Connector End Views** are now located at the end of individual cells and are shown for connectors with five or more cavities; a circuit function chart is provided.
- **NOTES, CAUTIONS and WARNINGS** contain important safety information.
- Full view "**COMPONENT LOCATION VIEWS**" (CELL 151) to help locate on-vehicle components.
- Circuit voltages have been added to schematic pages to help simplify troubleshooting. Nonessential troubleshooting hints have been deleted.
- **Cellular Pagination:** A specific section (or cell) in all EVTms is numbered by cell and starts with page 1. For example: "HOW TO USE THIS MANUAL" is CELL 2 and begins with page 2-1.
- "**IN-LINE CONNECTOR FACES**" (CELL 150) has been added for in-line connectors with six or more terminals, to aid in servicing electrical wiring.
- "C" numbers have been assigned for all electrical connectors. "C" numbers are listed in the "**LOCATION INDEX**" (CELL 152).

ORDERING INFORMATION

Information about how to order additional copies of this publication or other Ford publications may be obtained by writing to Helm Incorporated at the address shown below or by calling 1-800-782-4356. Other publications available include:

- Service Manuals
- Service Specification Books
- Car/Truck Wiring Diagrams
- Powertrain Control/Emissions Diagnosis Manuals

Helm Incorporated
P.O. Box 07150
Detroit, Michigan 48207



"WARRANTY CAUSAL PART NUMBERS" (CELL 153) has been added to aid in identifying warranty

maintain a suffix to denote connector "gender" type (F-socket, M-

TABLE OF CONTENTS/INDEX 1-2

1998 MUSTANG

G105	10-2	Fuse 5	13-12	Map	89-4, 89-5
G201	10-2	Fuse 6	13-5	Vanity Mirror	89-4, 89-5
G203	10-5	Fuse 7	13-5	Location Index	152-1
G204	10-7	Fuse 8	13-7	Main Light Switch	13-12
G205	10-5	Fuse 9	13-6	Mirrors (Power)	124-1
G300	10-11	Fuse 10	13-6	Power Distribution	13-1
Harness Causal Part Numbers	153-1	Fuse 11	13-5	Power Door Locks	
Headlamps	85-1	Circuit Breaker 12	13-7	Convertible	110-2
Heater	53-1	Fuse 13	13-12	Coupe	110-1
Horn	44-1	Circuit Breaker 14	13-5	Power Lumbar Seat	122-1
Ignition Switch	13-5, 13-6	Fuse 15	13-5	Power Mirrors	124-1
Ignition System		Fuse 16	13-8	Power Windows	100-1
3.8L	21-1	Fuse 17	13-5	Radio	
4.6L	21-3	Fuse 18	13-5	AM/FM Stereo	130-1
Indicators		Lamps (Exterior)		Premium Sound	
Air Bag	60-4	Backup	93-1	(w/out CD Player)	130-2
Anti-lock	60-4	Daytime Running	97-1	Premium Sound	
Anti-theft	60-2	Fog	86-1	(w/ CD Player)	130-3
Brake	60-4	Exterior	92-1	Super Sound	
Charge	60-2	Hazard	90-1	(w/out CD Player)	130-5
Fasten Belts	60-5	Headlamps	85-1	Super Sound	
Hi Beam	60-5	License	92-1	(w/ CD Player)	130-6
Left Turn	60-5	Park		Remote/Keyless Entry	111-1
Low Coolant	60-4	Front	92-1	Rear Window Defrost	56-1
Malfunction Indicator Lamp (MIL)		Rear	92-1	Seats (Lumbar)	122-1
(Check Engine)	60-1	Side Marker		Shift Lock	37-1
Right Turn	60-5	Front	92-1	Speed Control	31-1
Transmission Control Indicator		Rear	92-1	Starting System	20-1
Lamp (TCIL) (OD OFF)	60-1	Stop	90-3	Trunk Lid Release	113-1
In-Line Connector Faces	150-1	Stop (Hi Mount)	90-1	Turn/Stop/Hazard Lamps	90-1
Instrument Cluster	60-1	Turn		Vacuum Distribution	140-1
Instrument Illumination	71-1	Front	90-2	Vehicle Repair Location Codes	160-1
Interval Wiper/Washer	81-1	Rear	90-3	Vehicle Speed Sensor (VSS)	64-1
I/P Fuse Panel		Lamps (Interior)		Warning Chime	66-1
.....	13-6	Courtesy	89-1	Windows (Power)	100-1
.....	13-5	Dome	89-4, 89-5	Wiper/Washer (Interval)	81-1
.....	13-7	Instrument Illumination	71-1		
		Luggage Compartment	89-6		

100% SATISFACTION GUARANTEED

BUY IT NOW!

Click Here To Order

PayPal American Express Discover MasterCard VISA

1-3 TABLE OF CONTENTS/INDEX

1998 MUSTANG

IMPORTANT SAFETY NOTICE

Appropriate service methods and proper repair procedures are essential for the safe, reliable operation of all motor vehicles, as well as the personal safety of the individual doing the work. This Manual provides general directions for accomplishing service and repair work with tested, effective techniques. Following them will help assure reliability.

There are numerous variations in procedures, techniques, tools, and parts for servicing vehicles, as well as in the skill of the individual doing the work. This Manual cannot possibly anticipate all such variations and provide advice or cautions as to each. Accordingly, anyone who departs from the instructions provided in this Manual must first establish that he compromises neither his personal safety nor the vehicle integrity by his choice of methods, tools or parts.



BUY IT NOW!

Click Here To Order 



100% SATISFACTION GUARANTEED

BUY IT NOW!

Click Here To Order

PayPal American Express Discover MasterCard VISA

2-1 HOW TO USE THIS MANUAL

1998 MUSTANG

The purpose of this manual is to show electrical and vacuum circuits in a clear and simple fashion to make troubleshooting easier. **NOTES, CAUTIONS** and **WARNINGS** contain important information.

- **NOTES** describe how switches and other components operate to help complete a particular procedure.
- **CAUTIONS** provide information that could prevent making an error that may damage the vehicle.
- **WARNINGS** provide information to prevent personal injury.

The **WARNINGS** list on page 2-2 contains general warnings to follow when servicing a vehicle.

Components that work together are shown together. All electrical components used in a specific system are shown on one diagram. The circuit breaker or fuse is shown at the top of the page. All wires, connectors, components and splices are shown in the flow of current to ground at the bottom of the page. If a component is used in several different systems, it is shown in several places. For example, the Main Light Switch is electrically a part of many systems and is repeated on many pages.

In some cases, a component may seem (by its name) to belong to a system where it has no electrical connection. For example, Radio Illumination is electrically part of Instrument Illumination, but because it has no electrical connection to the Radio system, it is not shown on the Radio diagram.

Schematic pages contain references to full-view illustrations and description notes for various components. The references are reverse-text blocks

of the connector and location on page 2-2. Describe the

Schematic pages contain circuit voltages to help simplify troubleshooting hints. 12V is used to imply battery voltage on a component connector terminal, and 0V is used to show that there should be continuity to ground on that particular terminal. Conditional voltages such as "12V with the ignition switch in RUN" will also be provided. Troubleshooting hints that can't be simplified with circuit voltages will be shown at the end of each cell.

Component connector face information specific to a certain cell is found at the end of that cell. A Connector Face Reference List is provided to locate connector faces that are shown in different cells. Component connectors with five or more terminals are illustrated and are accompanied by a pinout chart that lists the function of all circuitry associated with that component.

"**GROUNDINGS**" (Cell 10) contains ground circuitry shown in complete detail. This information is useful for checking interconnections of the ground circuits of different systems.

"**POWER DISTRIBUTION**" (Cell 13) contains power distribution circuitry shown in complete detail. This section displays how the various fuses are powered and, in turn, how each system is powered.

"**COMPONENT TESTING**" (Cell 149) contains testing procedures for various switches. This information includes schematics, component terminal locations and step-by-step procedures.

"**IN-LINE CONNECTOR FACES**" (Cell 150) contains illustrations of all the in-line connectors that have 6 or more terminals. The terminals have pin numbers assigned to them.

"**COMPONENT LOCATION VIEWS**" (Cell 151) contains full-view illustrations which show the location of all components and connectors in the vehicle.

The "**LOCATION INDEX**" (Cell 152) provides the base part numbers, locations, connector face references and illustration references for all components, connectors, splices and grounds.

HELPFUL REMINDERS

Before using the EVTM for troubleshooting, refer to these **HELPFUL REMINDERS**:

1. The abbreviation T/O, for take out, used in the Location Index (Cell 152), refers to the point at which a group of wires branch off the harness trunk. Refer to the wiring harness illustration.

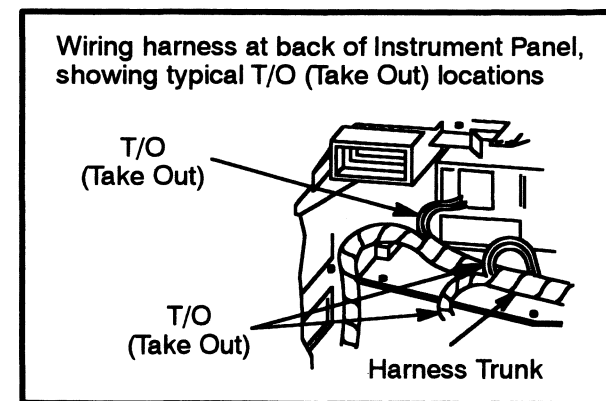

2. If a connector serves the same purpose in two separate versions (e.g., Automatic/Manual), but is physically different, *two* connector numbers are used. However, if a connector serves the same purpose in two separate versions (e.g., Automatic/Manual) and is physically the same, but the wire colors are different, *only one* connector number is used. If the same physical connector is used more than once, then more than *one* connector number is used.

100% SATISFACTION GUARANTEED

BUY IT NOW!

Click Here To Order

PayPal American Express Cards DISCOVER NOVUS MasterCard VISA

3. Wiring schematics provide a picture of how and under what conditions the circuit is powered, of the current path to circuit components, and of how a circuit is grounded. Each circuit component is named (underlined titles). Wire and connector colors are listed as follows (standard Ford color abbreviations are used):

COLOR ABBREVIATIONS

BL	Blue	N	Natural
BK	Black	O	Orange
BR	Brown	PK	Pink
DB	Dark Blue	P	Purple
DG	Dark Green	R	Red
GN	Green	T	Tan
GY	Gray	W	White
LB	Light Blue	Y	Yellow
LG	Light Green		

Note: Whenever a wire is labeled with two colors, the first color listed is the basic color of the wire, and the second color listed is the stripe marking of the wire.

4. When reporting Vehicle Repair Location Codes to Ford Customer Service Division, refer to Cell 160 (beginning on page 160-1). Note: Do *not* use the illustrations in Cell 151 (beginning on page 151-1) for reporting Vehicle Repair Location Codes.

5. WARNINGS

- *Always wear safety glasses for eye protection.*
- *Use safety stands whenever a procedure requires being under a vehicle.*
- *Be sure that the **Ignition Switch** is always in the OFF position, unless otherwise required by the procedure.*
- *Set the parking brake when working on any vehicle. An automatic transmission should be in PARK. A manual transmission should be in NEUTRAL.*
- *Operate the engine only in a well-ventilated area to avoid danger of carbon monoxide.*
- *Keep away from moving parts, especially the fan and belts, when the engine is running.*
- *To prevent serious burns, avoid contact with hot metal parts such as the radiator, exhaust manifold, tail pipe, catalytic converter and muffler.*
- *Do not allow flame or sparks near the battery. Gases are always present in and around the battery cell. An explosion could occur.*
- *Do not smoke when working on a vehicle.*
- *To avoid injury, always remove rings, watches, loose hanging jewelry and avoid wearing loose clothing.*

HOW TO FIND ELECTRICAL CONCERNS

TROUBLESHOOTING STEPS

These six steps present an orderly method of troubleshooting.

Step 1. Verify the concern.

- Operate the complete system to check the accuracy and completeness of the customer's complaint.

Step 2. Narrow the concern.

- Using the EVTm, narrow down the possible causes and locations of the concern to pinpoint the exact cause.
- Read the description notes at the components and study the wiring schematic. You should then know enough about the circuit operation to determine where to check for the trouble. Further information can be found by referring to the Service Manual pages listed in the box at the top of the page.

Step 3. Test the suspected cause.

- Use electrical test procedures to find the specific cause of the symptoms.
- The component location reference bars and the pictures will help you find components. The Location Index (at the end of the manual) gives component location information for connectors, diodes, resistors, splices and grounds.

Step 4. Verify the cause.

- Confirm that you have found the correct cause by connecting jumper wires and/or temporarily installing a known good component and operating the circuit.

Step 5. Make the repair.

- Repair or replace the inoperative component.

Step 6. Verify the repair.

- Operate the system as in Step 1 and check that your repair has removed all symptoms without creating any new symptoms.

100% SATISFACTION GUARANTEED

BUY IT NOW!

Click Here To Order

PayPal American Express Discover MasterCard VISA

2-3 HOW TO USE THIS MANUAL

1998 MUSTANG

Some engine circuits may need special test equipment and special procedures. See the *Service Manual* and other service books for details. You will find the circuits in this manual to be helpful with those special test procedures.

TROUBLESHOOTING TOOLS

JUMPER WIRE

This is a test lead used to connect two points of a circuit. A Jumper Wire can bypass an open to complete a circuit.

WARNING

Never use a jumper wire across loads (motors, etc.) connected between hot and ground. This direct battery short may cause injury or fire.

VOLTMETER

A DC Voltmeter measures circuit voltage. Connect negative (- or black) lead to ground, and positive (+ or red) lead to voltage measuring point.

OHMMETER

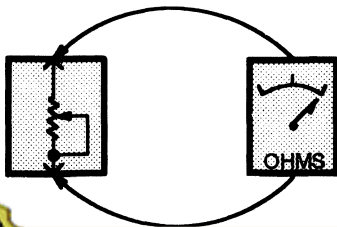

100% SATISFACTION GUARANTEED

BUY IT NOW!

Click Here To Order

PayPal American Express Discover/Novus MasterCard VISA

An Ohmmeter shows the resistance between two connected points (Figure 1).

TEST LAMP

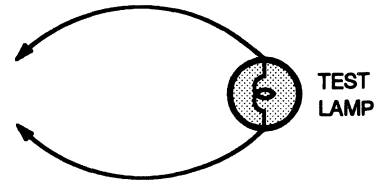

Figure 2 – Test Lamp

A Test Light is a 12-volt bulb with two test leads (Figure 2).

Uses: Voltage Check, Short Check.

SELF-POWERED TEST LAMP

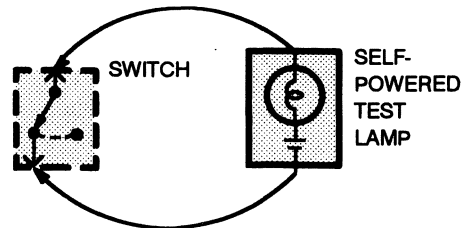

Figure 3 – Continuity Check

The Self-Powered Test Lamp is a bulb, battery and set of test leads wired in series (Figure 3). When connected to two points of a continuous circuit, the bulb glows.

Uses: Continuity Check, Ground Check.

CAUTION

When using a self-powered test lamp or ohmmeter, be sure power is off in circuit during testing. Hot circuits can cause equipment damage and false readings.

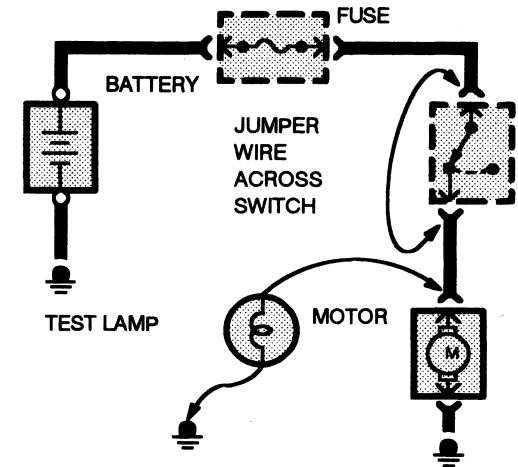

Figure 4 – Switch Circuit Check and Voltage Check

In an inoperative circuit with a switch in series with the load, jumper the terminals of the switch to power the load. If jumpering the terminals powers the circuit, the switch is inoperative (Figure 4).

CONTINUITY CHECK (Locating open circuits)

Connect one lead of Self-Powered Test Lamp or Ohmmeter to each end of circuit (Figure 3). Lamp will glow if circuit is closed. Switches and fuses can be checked in the same way.

VOLTAGE CHECK

Connect one lead of test lamp to a known good ground or the negative (-) battery terminal. Test for voltage by touching the other lead to the test point. Bulb goes on when the test point has voltage (Figure 4).

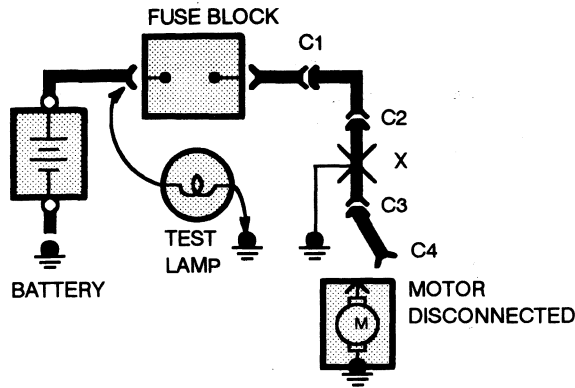

Figure 5 – Short Check

A fuse that repeatedly blows is usually caused by a short to ground. It's important to be able to locate such a short quickly (Figure 5).

1. Turn off everything powered through the fuse.
2. Disconnect other loads powered through the fuse:
 - Motors: disconnect motor connector (Connector C4 in Figure 5).
 - Lights: remove bulbs.

4. Connect one Test Lamp lead to hot end of blown fuse. Connect other lead to ground. Bulb should glow, showing power to fuse. *(This step is just a check to be sure you have power to the circuit.)*
5. Disconnect the test lamp lead that is connected to ground, and reconnect it to the load side of the fuse at the connector of the disconnected component. (In Figure 5, connect the test lamp lead to connector C4.)

- If the Test Lamp is off, the short is in the disconnected component.
- If the Test Lamp goes on, the short is in the wiring. You must find the short by disconnecting the circuit connectors, one at a time, until the Test Lamp goes out. For example, in Figure 5 with a ground at X, the bulb goes out when C1 or C2 is disconnected, but not after disconnecting C3. This means the short is between C2 and C3.

Turn on power to the circuit. Perform a Voltage Check between the suspected inoperative ground and the frame. Any indicated voltage means that the ground is inoperative (Figure 6).

Turn off power to the circuit. Connect one lead of a Self-Powered Test Lamp or Ohmmeter to the wire in question and the other lead to a known ground. If the bulb glows, the circuit ground is OK (Figure 6).

The circuit schematics in this manual make it easy to identify common points in circuits. This knowledge can help narrow the concern to a specific area. For example, if several circuits fail at the same time, check for a common power or ground connection (see *Power Distribution* or *Grounds*). If part of a circuit fails, check the connections between the part that works and the part that doesn't work.

For example, if the lo beam headlamps work, but the high beams and the indicator lamp don't work, then power and ground paths must be good. Since the dimmer switch is the component that switches this power to the high beam lights and indicator, it is most likely the cause of failure.

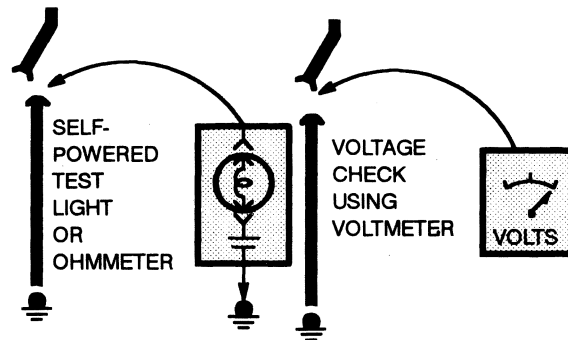

Figure 6 – Ground Check

Turn Ignition Switch to RUN (if necessary) to test for fuse.

100% SATISFACTION GUARANTEED

BUY IT NOW!

Click Here To Order

PayPal, American Express, Discover, MasterCard, VISA

2-5 HOW TO USE THIS MANUAL

1998 MUSTANG

TROUBLESHOOTING WIRING HARNESS AND CONNECTOR HIDDEN CONCERNS

The following illustrations are known examples of wiring harness, splices and connectors that will create intermittent electrical concerns. The concerns are hidden and can only be discovered by a physical evaluation as shown in each illustration.

NOTE: Several components, such as the PCM, utilize gold plated terminals in their connections to the wiring harness. If those terminals need to be replaced, they must be replaced with a gold plated terminal.

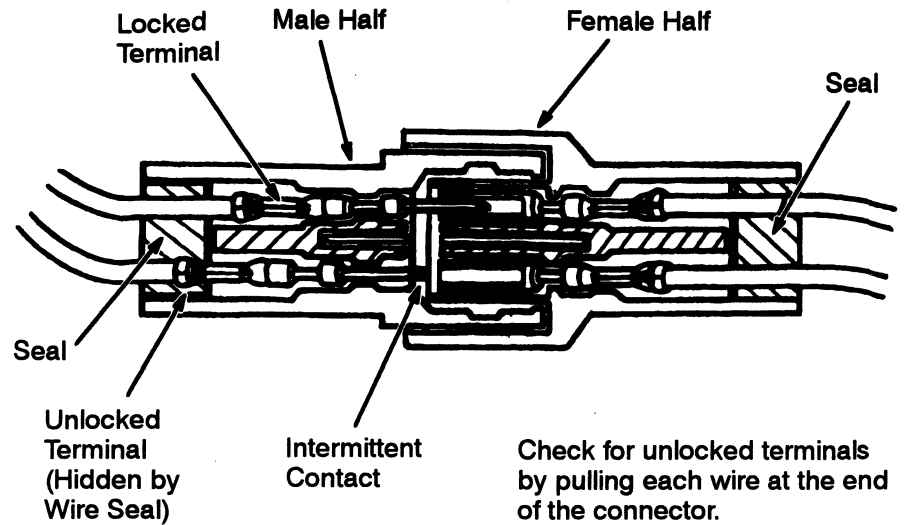

TERMINAL NOT PROPERLY SEATED

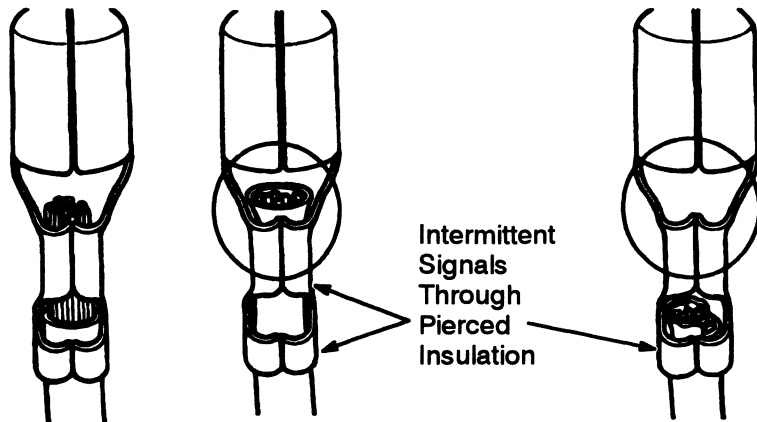

Proper Strip

Insulation Not

Wire Strands Missing

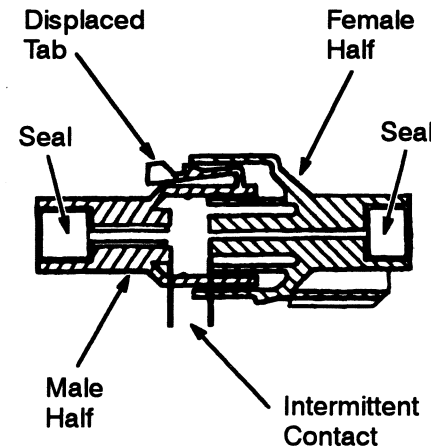

Lock may be displaced into an unlocked position; pull on the connector to verify the lock.

Type A

Type B

PARTIALLY MATED CONNECTORS

100% SATISFACTION GUARANTEED

BUY IT NOW!

Click Here To Order

PayPal

MasterCard

VISA

ION STRIPPING

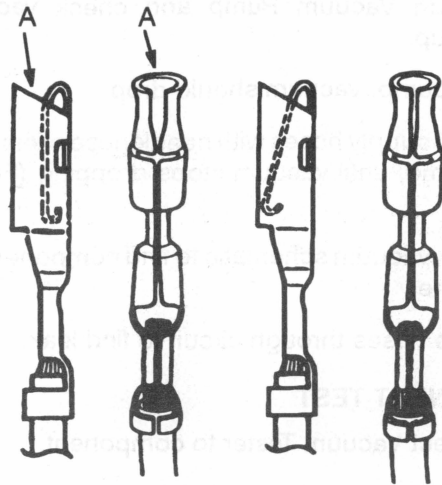

Enlarged Normal

Any probe entering the terminal may enlarge the contact spring opening creating an intermittent signal. Insert the correct mating terminal (Location A) from the service kit and feel for a loose fit.

DEFORMED (ENLARGED) FEMALE TERMINALS

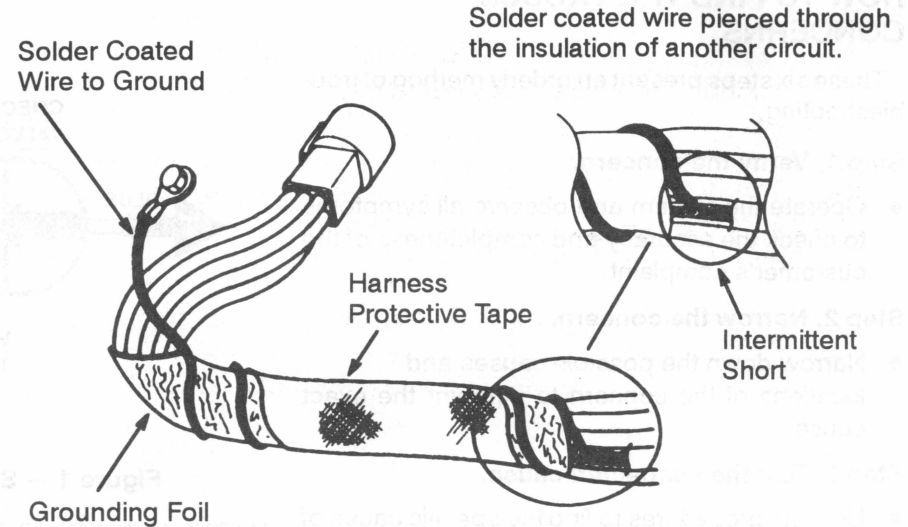

ELECTRICAL SHORT INSIDE THE HARNESS

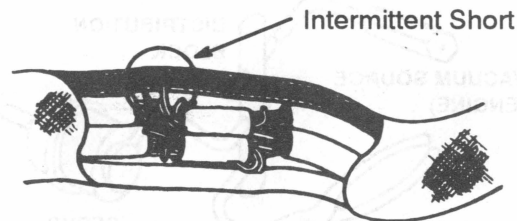

Operate the system and flex the harness at splice location noted in Section 152.

Splice Tape Removed

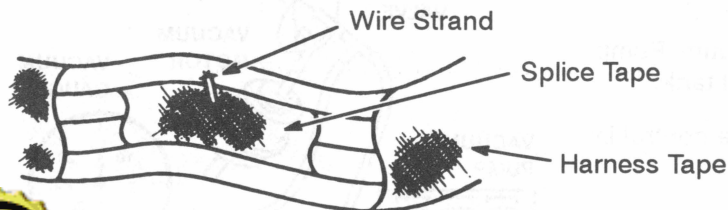

WITHIN THE HARNESS

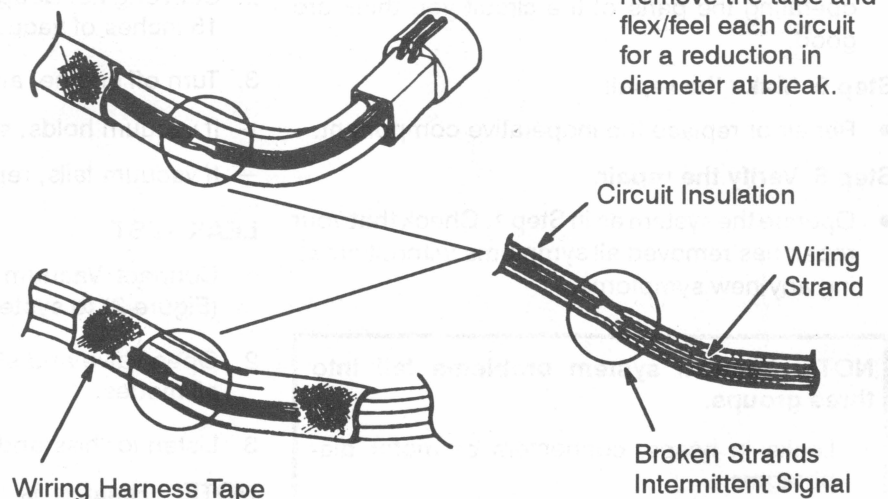

BROKEN WIRE STRANDS IN HARNESS

100% SATISFACTION GUARANTEED

BUY IT NOW!

Click Here To Order

PayPal American Express Discover Novus MasterCard VISA

2-7 HOW TO USE THIS MANUAL

1998 MUSTANG

HOW TO FIND THE VACUUM CONCERNS

These six steps present an orderly method of troubleshooting.

Step 1. Verify the concern.

- Operate the system and observe all symptoms to check the accuracy and completeness of the customer's complaint.

Step 2. Narrow the concern.

- Narrow down the possible causes and locations of the concern to pinpoint the exact cause.

Step 3. Test the suspected cause.

- Use test procedures to find the specific cause of the symptoms.

Step 4. Verify the cause.

- Confirm that you have found the right cause by operating the parts of the circuit you think are good.

Step 5. Make the repair.

- Repair or replace the inoperative component.

Step 6. Verify the repair.

- Operate the system as in Step 1. Check that your repair has removed all symptoms without creating any new symptoms.

NOTE: Vacuum system problems fall into three groups.

1. Leaking hoses, connectors or motor diaphragms.

2. Faulty Check Valve or Vacuum Tank.

3. Faulty Vacuum Pump.

BUY IT NOW!

Click Here To Order

PayPal American Express Discover NEWUS MasterCard VISA

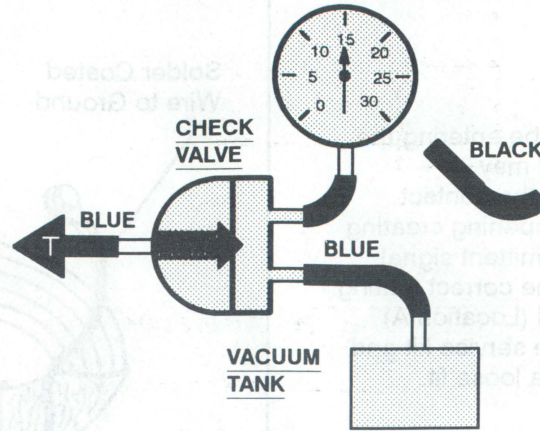

Figure 1 – System Supply Test

VACUUM SUPPLY TEST

1. Connect Vacuum Tester to system side of Check Valve (Figure 1).
2. Start engine. Gauge should show approximately 15 inches of vacuum.
3. Turn off engine, and observe gauge:
 - If vacuum holds, supply OK.
 - If vacuum fails, replace Check Valve or Tank.

LEAK TEST

1. Connect Vacuum Gauge and Vacuum Pump (Figure 2) to system hose in place of tank.
2. Open valve and start pump. Operate control in all modes.
3. Listen for hiss and observe gauge.

NOTE: Hissing is normal at Function Control when changing modes.

If system hisses or loses vacuum, find system leak as follows:

1. Turn on Vacuum Pump and check vacuum build-up.
2. Stop pump; vacuum should drop.
3. Clamp supply hoses with needlenose pliers, one at a time, until vacuum stops dropping (Figure 2).
4. Check vacuum schematic to find components in that line.
5. Clamp hoses through circuit to find leak.

COMPONENT TEST

1. Connect Vacuum Tester to component.
2. Pump Vacuum Tester. Check that all components operate correctly and vacuum holds.
3. Replace component if vacuum does not hold.

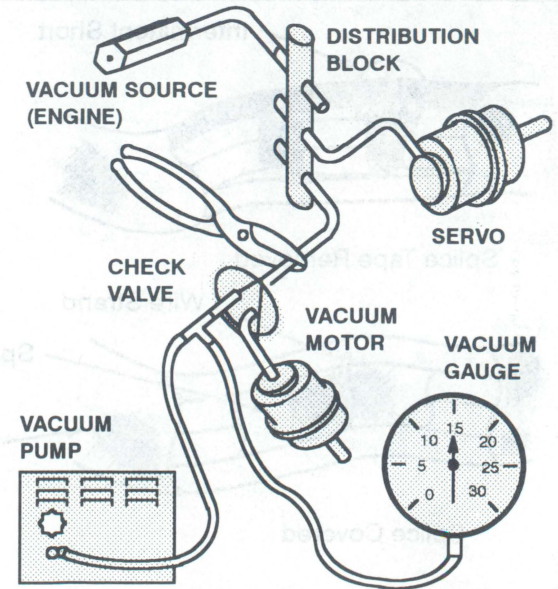
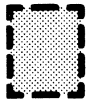
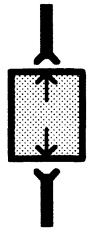

Figure 2 – Testing For Leaks In Typical Vacuum System

ELECTRICAL SYMBOLS



DASHED COMPONENT BOX
ONLY PART OF THE COMPONENT IS SHOWN ON THE PAGE; THE COMPONENT IS SHOWN COMPLETE IN ANOTHER LOCATION



COMPONENT WITH CONNECTORS

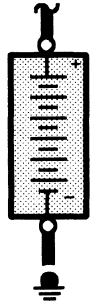

BATTERY

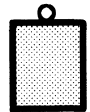

SCREW TERMINAL ON COMPONENT



SEALED ELECTRONIC COMPONENT
ANY CIRCUITRY SHOWN INSIDE THE BOX IS A FUNCTIONAL EQUIVALENT ONLY

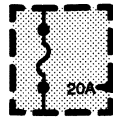

FUSE
CURRENT RATING

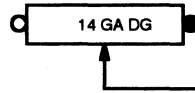

FUSIBLE LINK
WIRE SIZE AND COLOR

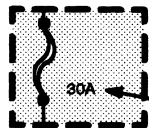

MAXI-FUSE or FUSIBLE LINK CARTRIDGE
CURRENT RATING

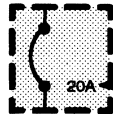

CIRCUIT BREAKER
CURRENT RATING

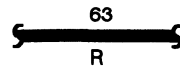

SOLID WIRES

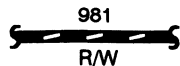

STRIPED WIRES

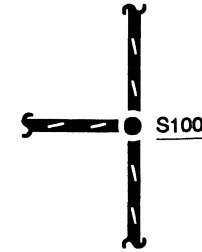

SPLICE OR CRIMP TERMINAL

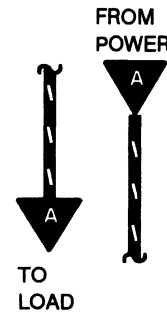

"CUT" WIRES REFERENCED BETWEEN PAGES
ARROWS SHOW CURRENT FLOW FROM POWER TO GROUND



BACKUP LIGHTS

"REFERENCE" WIRES
COMPLETE WIRING SHOWN ON ANOTHER PAGE

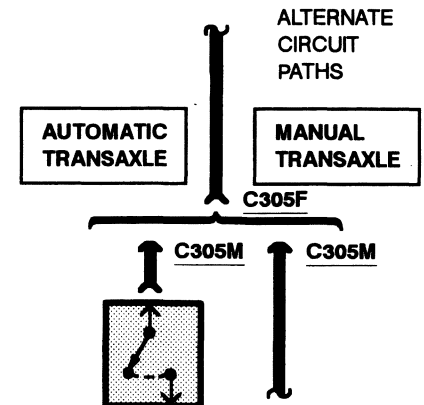

SOLID STATE

100% SATISFACTION GUARANTEED

BUY IT NOW!

Click Here To Order

2-9 HOW TO USE THIS MANUAL

1998 MUSTANG

ELECTRICAL SYMBOLS

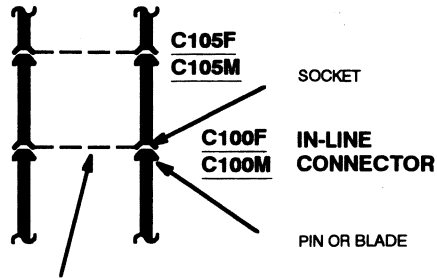

SINGLE DASHED LINE INDICATES THAT WIRE ON LEFT ALSO PASSES THROUGH THE SAME CONNECTOR

SEE GROUNDS
PAGES 10-1,
10-2

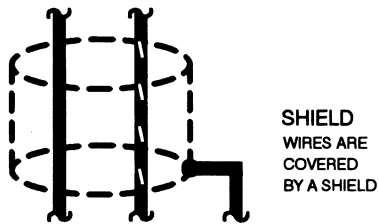
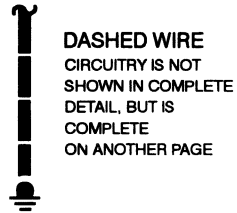

MOTOR



HEATING ELEMENT



THERMISTOR



RHEOSTAT OR POTENTIOMETER



SOLENOID

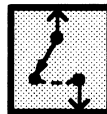

SWITCH

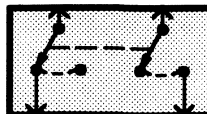

GANGED SWITCHES
CONTACTS MOVE AT THE SAME TIME

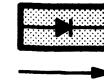

DIODES
CURRENT FLOWS IN DIRECTION OF ARROW ONLY

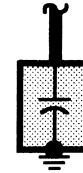

CAPACITOR



TRANSISTOR

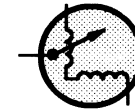

GAUGE



LIGHT EMITTING DIODE (LED)



LIGHT BULB

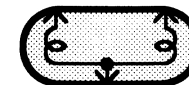

DUAL FILAMENT LIGHT BULB

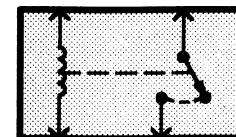

RELAY
CONTACTS CHANGE POSITION WITH CURRENT THROUGH COIL

100% SATISFACTION GUARANTEED

BUY IT NOW!

Click Here To Order

HOW TO USE THIS MANUAL 2-10

1998 MUSTANG

VACUUM SYMBOLS

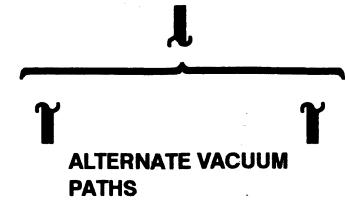
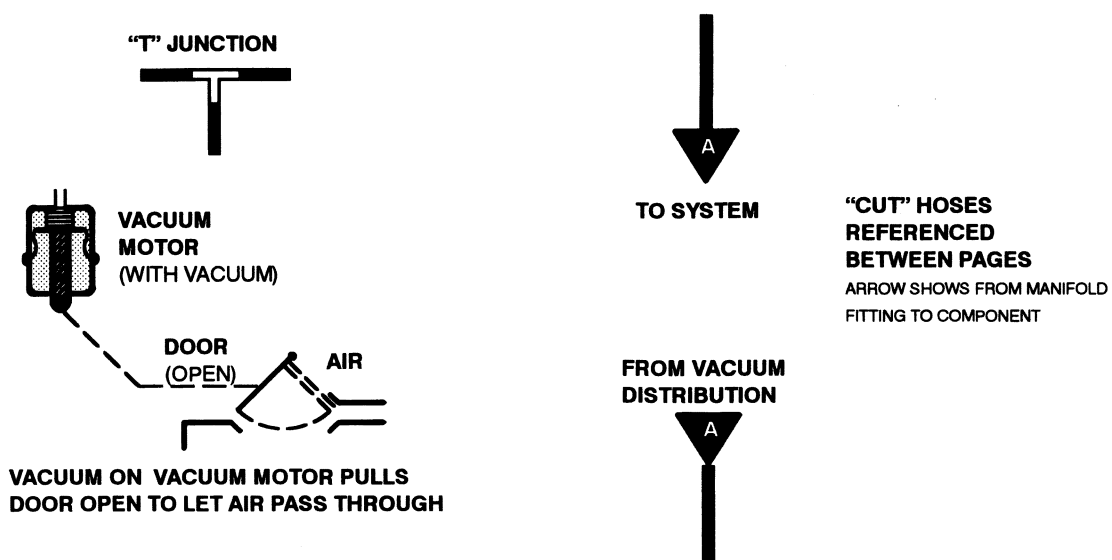

Note: Other vacuum symbols used on vacuum system diagrams are fully explained on the pages where they appear.

VACUUM MOTOR OPERATION

SINGLE DIAPHRAGM MOTOR

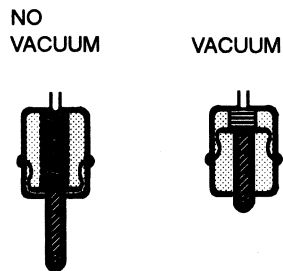

SERVO MOTOR

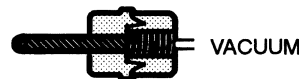

Some vacuum motors can position the actuating arm at any position between fully extended and fully retracted. The Servo is operated by a control valve that applies varying amounts of vacuum to the motor. The higher the vacuum level, the greater the retraction of the motor arm. Servo Motors work nearly the same way as two-position motors, except for the way the vacuum is applied. Servo Motors are generally larger and provide a calibrated control.

DOUBLE DIAPHRAGM MOTOR

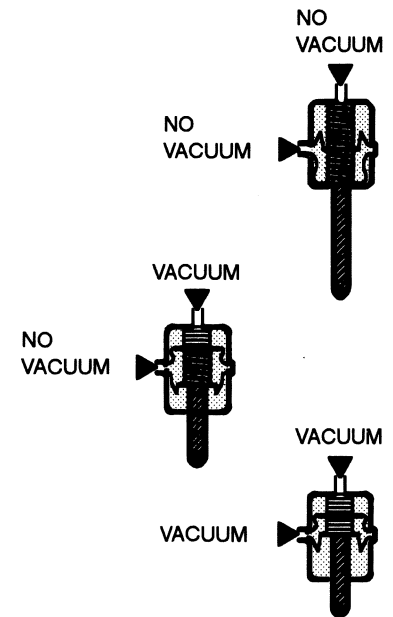

A double diaphragm motor has three positions (it is actually two motors in one housing). When the top port gets vacuum, the shaft pulls halfway in. When both ports get vacuum, the shaft pulls all the way in.

Some motors operate like electrical solenoids, with a spring between the arm and the shaft. When vacuum is not applied, the spring returns the arm to its original position.

100% SATISFACTION GUARANTEED

BUY IT NOW!

Click Here To Order

PayPal American Express Discover Novus MasterCard VISA

10-1 GROUNDS

1998 MUSTANG

All wires are 57 (BK)
unless otherwise noted.

ENGINE COMPARTMENT FUSE BOX

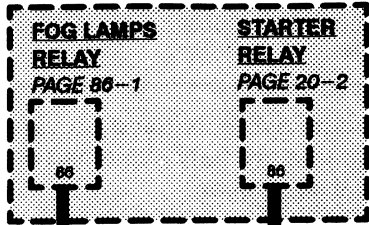

LEFT
FOG
LAMP
PAGE 88-1



S110

LEFT FRONT
PARK/TURN
LAMP
PAGES 90-2,
92-1



LEFT
HEADLAMP
PAGES 85-1,
97-2



WASHER
PUMP
MOTOR
PAGE 81-1

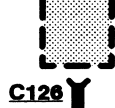

RIGHT FOG
LAMP
PAGE 88-1



S106

FROM S100
PAGE 10-3



C109M
C109F

151-2 F3

ANTI-LOCK
BRAKE
CONTROL
MODULE
PAGE 42-1

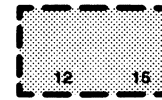

C141

RIGHT
HEADLAMP
PAGES
85-1, 97-2



S104

RIGHT FRONT
PARK/TURN
LAMP
PAGES 90-2,
92-1



C123

G103

151-2 E1

S103

G102

151-1 E10

100% SATISFACTION GUARANTEED

BUY IT NOW!

Click Here To Order

PayPal, American Express, Discover, MasterCard, VISA

10-3 GROUNDS

1998 MUSTANG

All wires are 57 (BK)
unless otherwise noted.

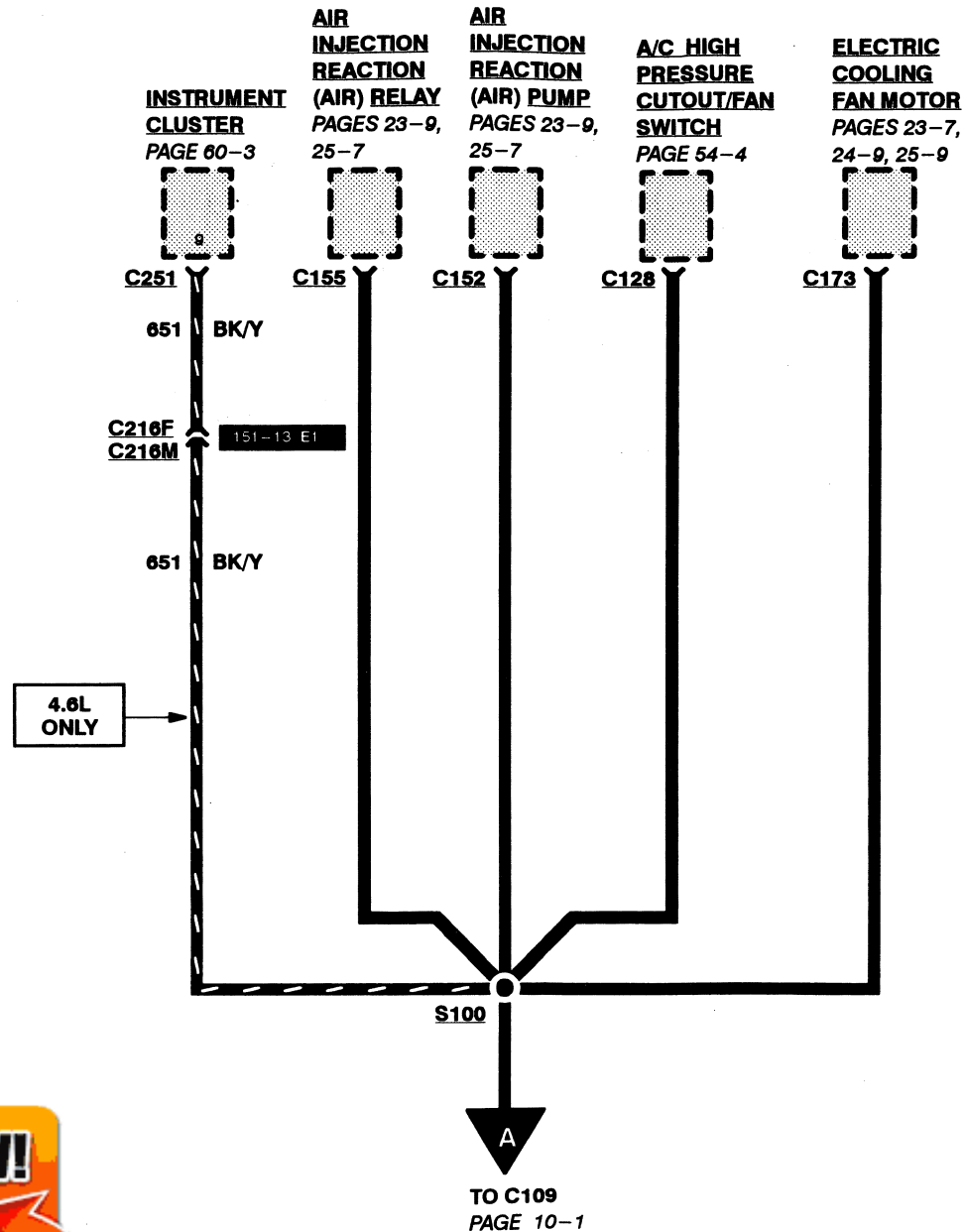

100% SATISFACTION GUARANTEED

BUY IT NOW!

Click Here To Order

PayPal | American Express | Discover | MasterCard | VISA

GROUPS 10-4

1998 MUSTANG

All wires are 57 (BK) unless otherwise noted.

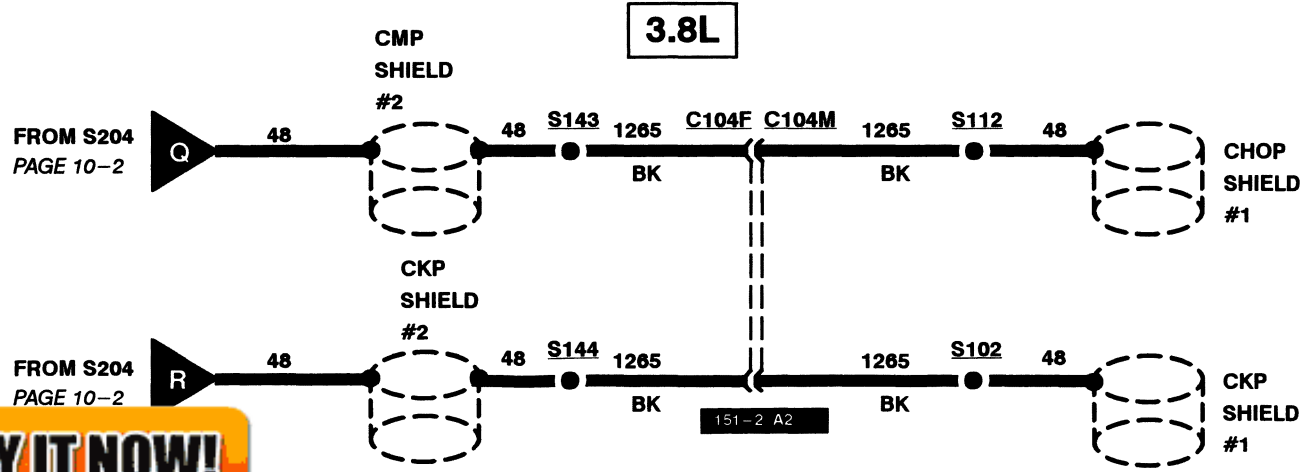
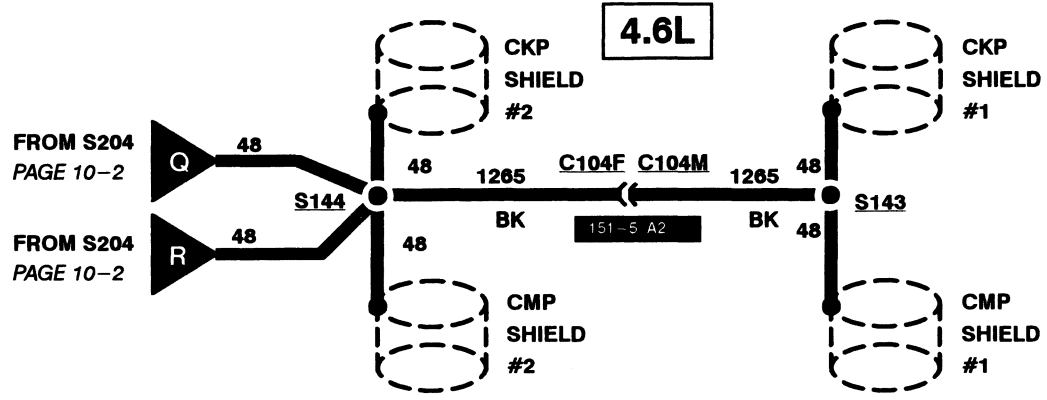

100% SATISFACTION GUARANTEED

BUY IT NOW!

Click Here To Order

PayPal, American Express, Discover, MasterCard, VISA

10-5 GROUNDS

1998 MUSTANG

All wires are 57 (BK) unless otherwise noted.

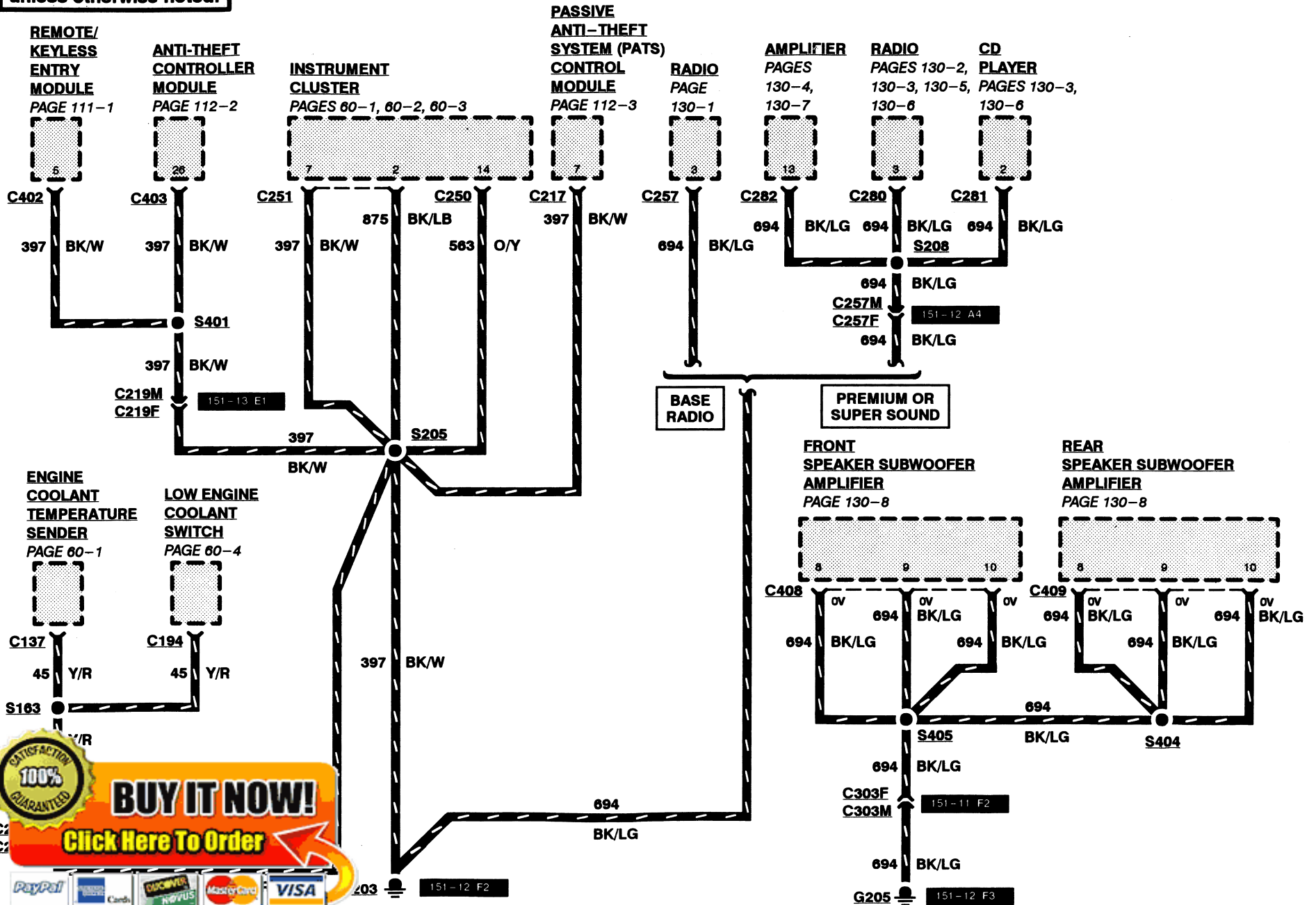

100% SATISFACTION GUARANTEED

BUY IT NOW!

[Click Here To Order](#)

All wires are 57 (BK) unless otherwise noted.

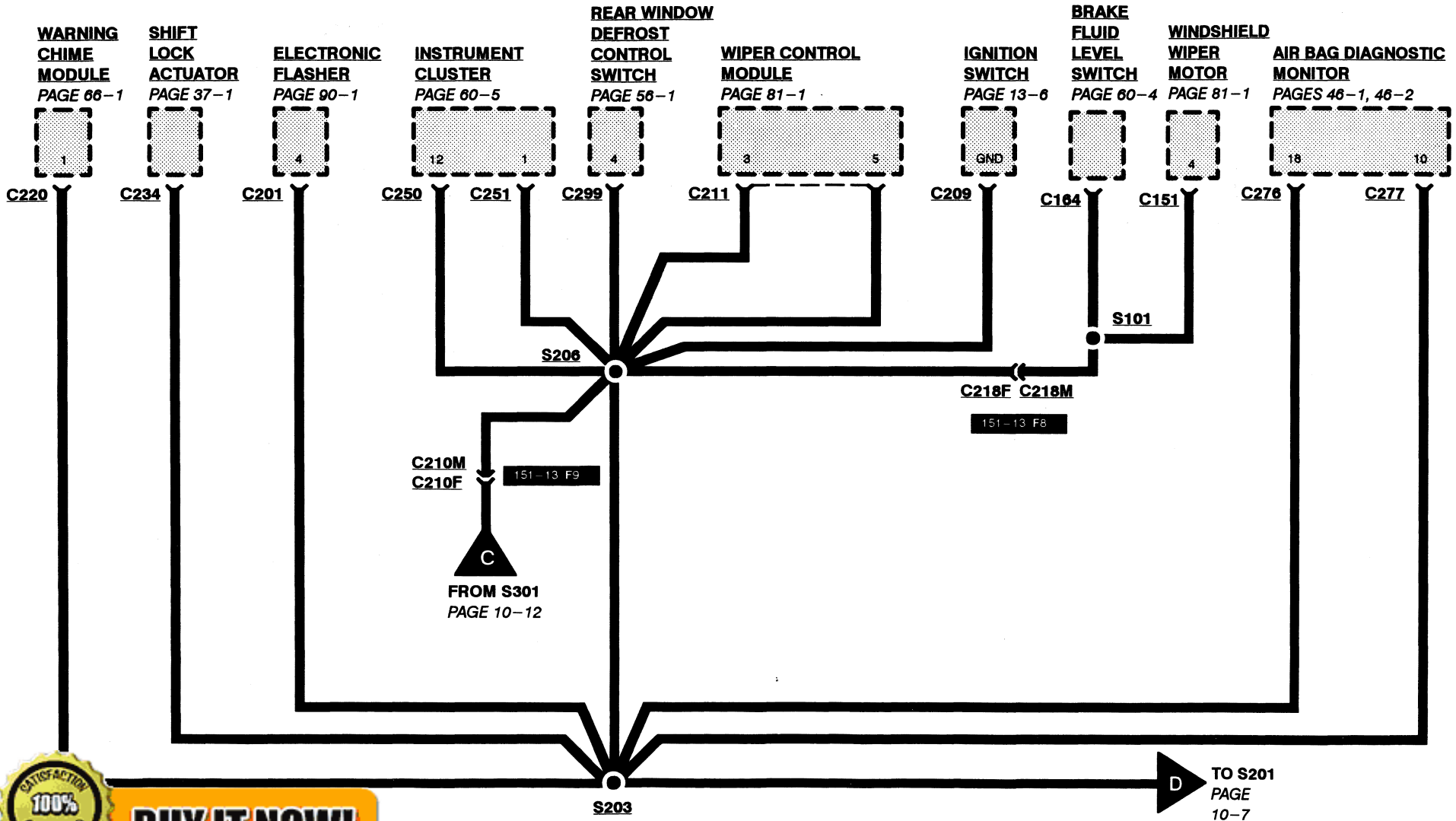

100% SATISFACTION GUARANTEED

BUY IT NOW!

Click Here To Order

PayPal American Express Discover MasterCard VISA

10-7 GROUNDS

1998 MUSTANG

All wires are 57 (BK) unless otherwise noted.

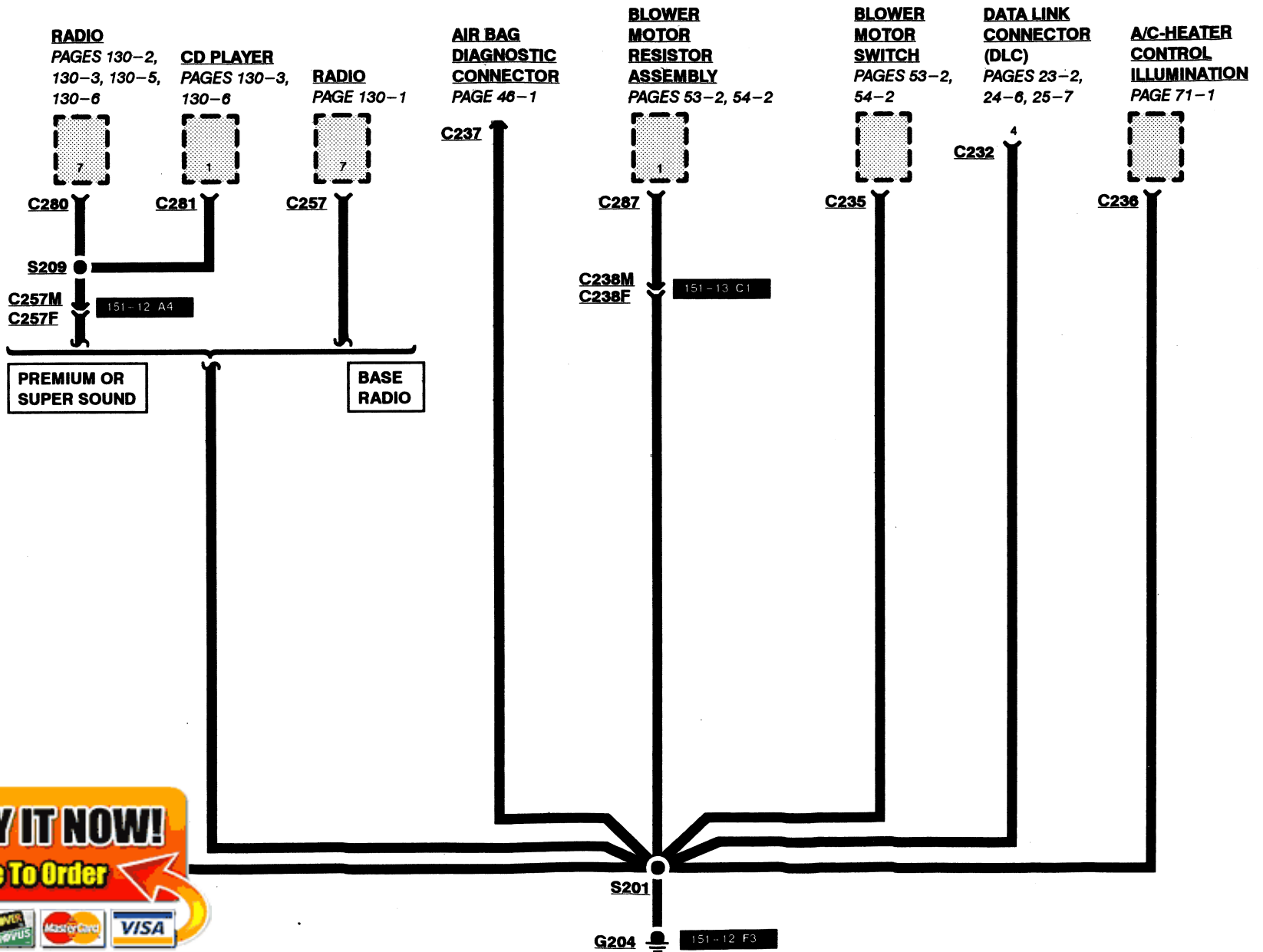

100% SATISFACTION GUARANTEED

BUY IT NOW!

Click Here To Order

PayPal, American Express, Discover, MasterCard, VISA

All wires are 57 (BK) unless otherwise noted.

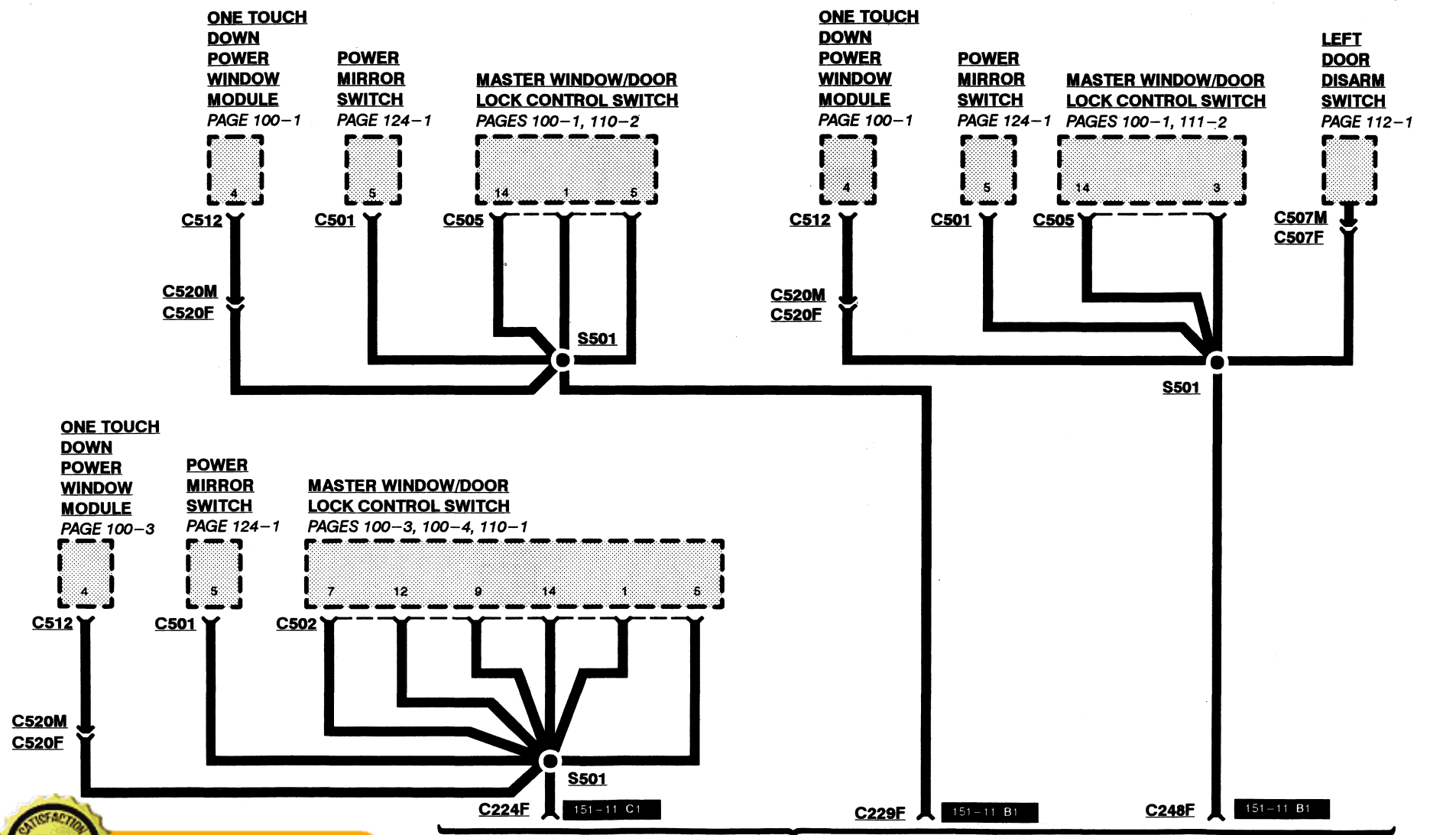

100% SATISFACTION GUARANTEED

BUY IT NOW!

Click Here To Order

PayPal American Express Discover MasterCard VISA

COUPE WITH POWER WINDOWS/ DOOR LOCKS WITHOUT REMOTE KEYLESS ENTRY

↓
E
TO S301
PAGE 10-12

CONVERTIBLE WITH POWER WINDOWS/ DOOR LOCKS WITHOUT REMOTE/KEYLESS ENTRY

CONVERTIBLE WITH POWER WINDOWS/ DOOR LOCKS, REMOTE/KEYLESS ENTRY, AND/OR ANTI-THEFT

10-9 GROUNDS

1998 MUSTANG

All wires are 57 (BK) unless otherwise noted.

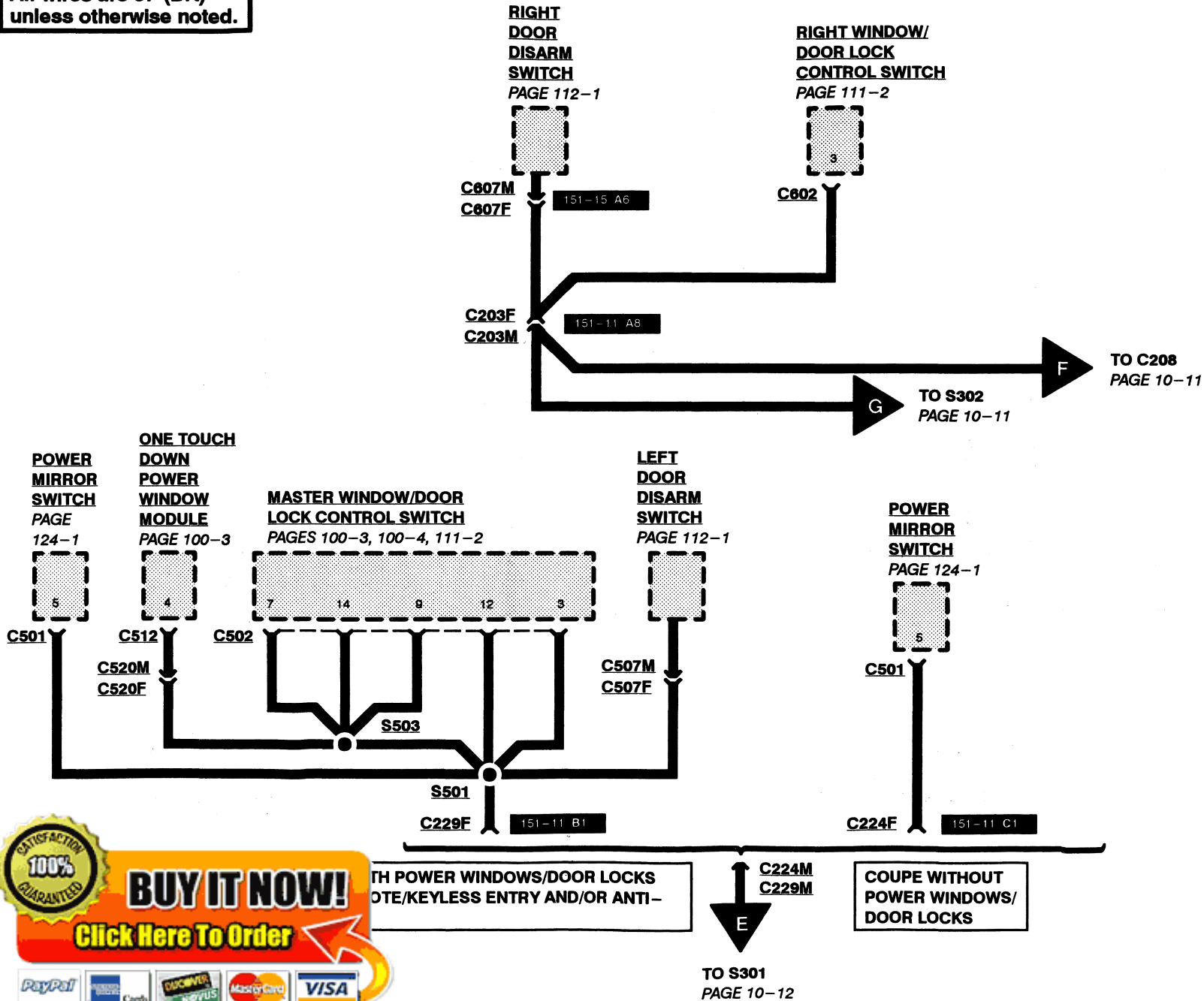

All wires are 57 (BK)
unless otherwise noted.

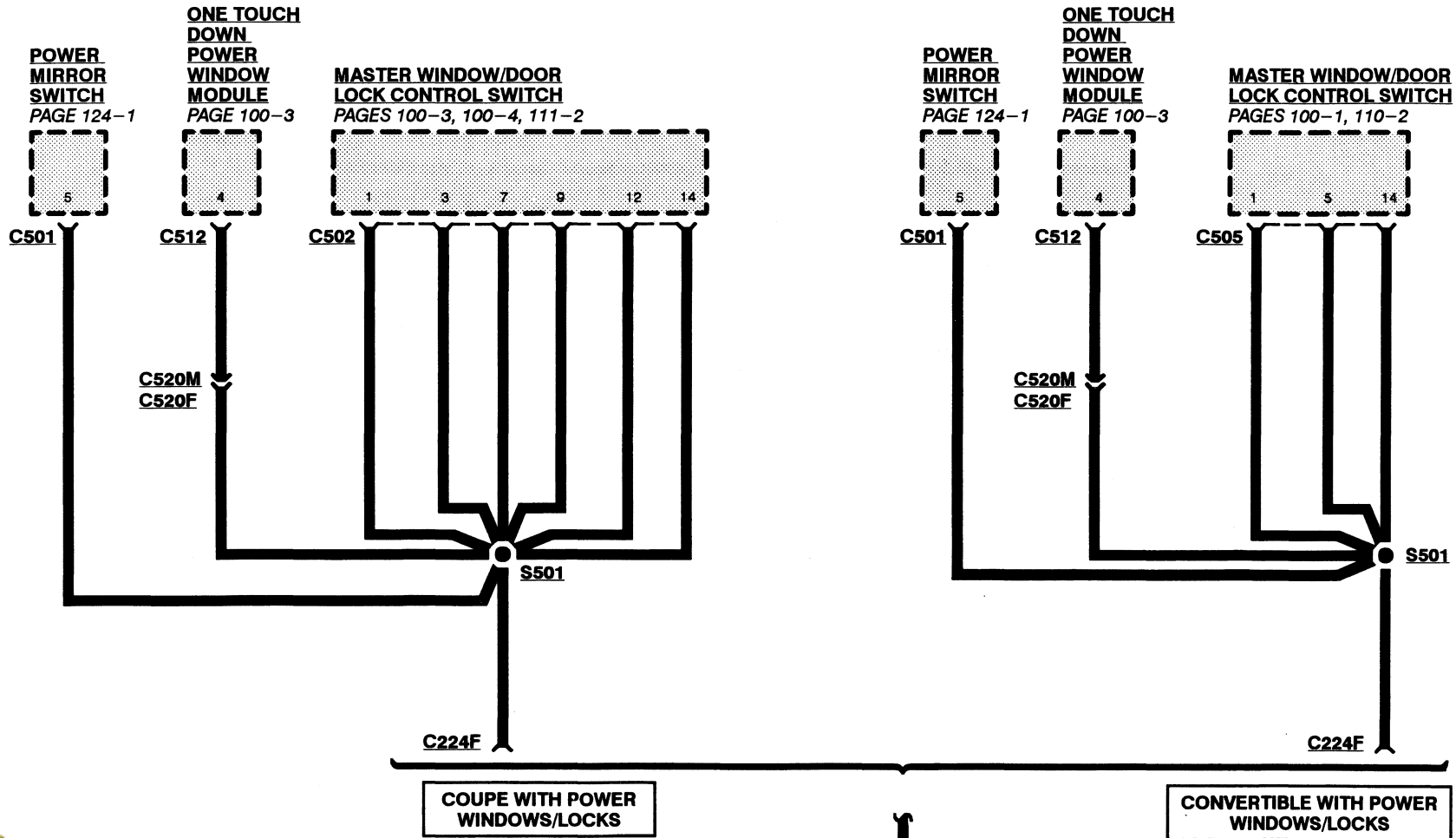

100% SATISFACTION GUARANTEED

BUY IT NOW!

Click Here To Order

PayPal American Express Discover MasterCard VISA

TO S301
PAGE 10-12

10-11 GROUNDS

1998 MUSTANG

All wires are 57 (BK)
unless otherwise noted.

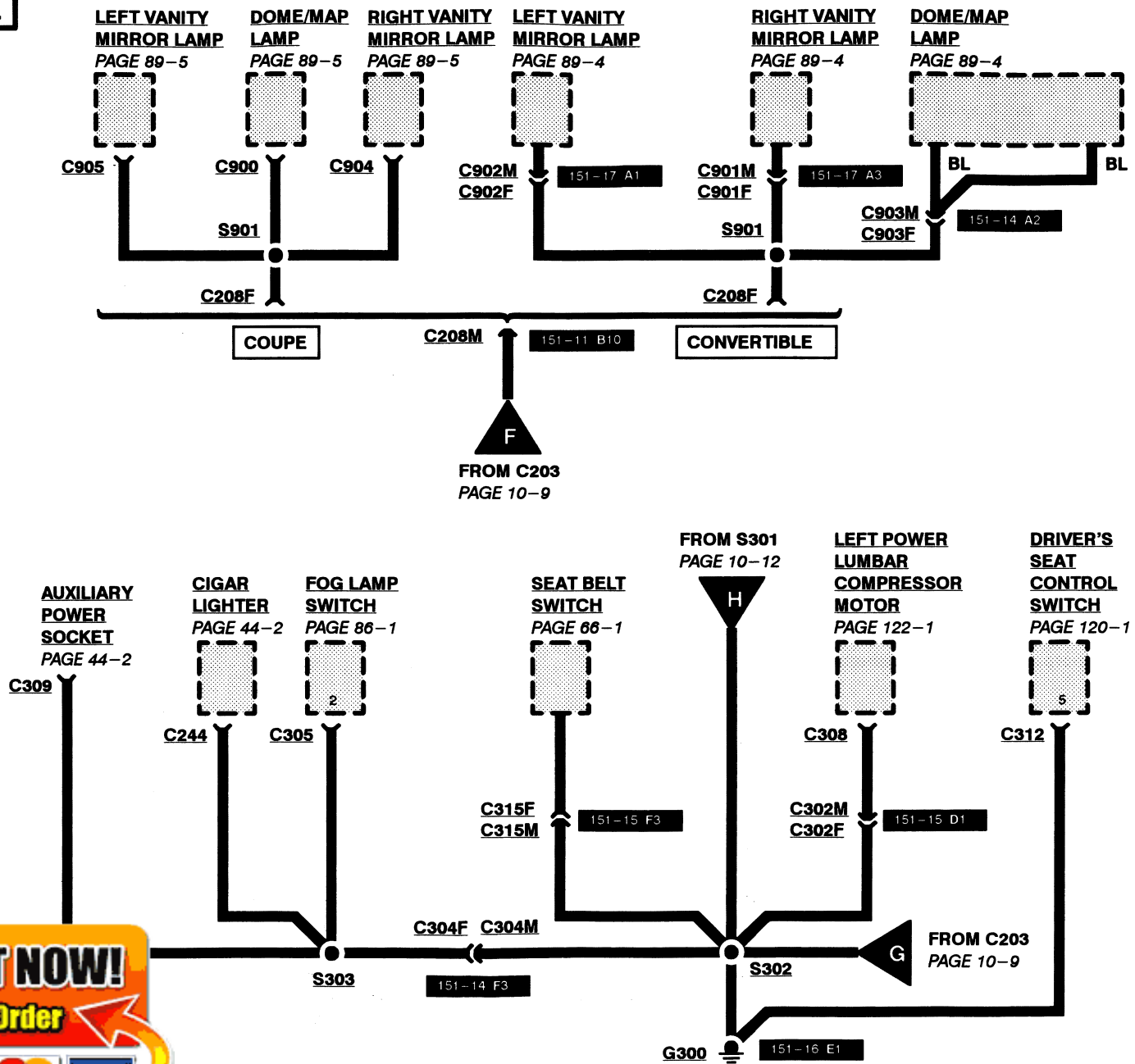

100% SATISFACTION GUARANTEED

BUY IT NOW!

Click Here To Order

PayPal Discover/Novus MasterCard VISA

All wires are 57 (BK) unless otherwise noted.

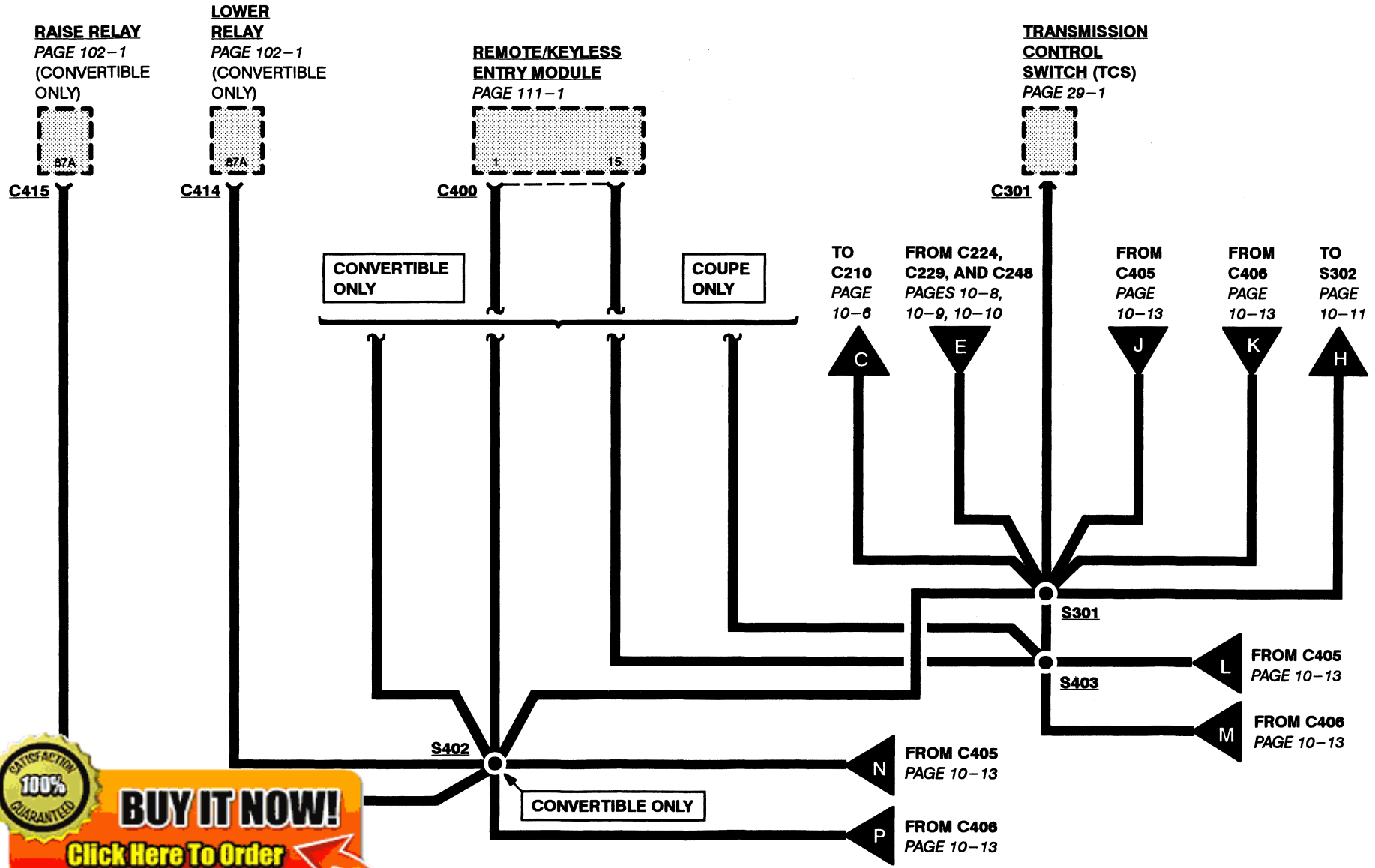

100% SATISFACTION GUARANTEED

BUY IT NOW!

Click Here To Order

PayPal American Express Cards Discover Novus MasterCard VISA

10-13 GROUNDS

1998 MUSTANG

All wires are 57 (BK) unless otherwise noted.

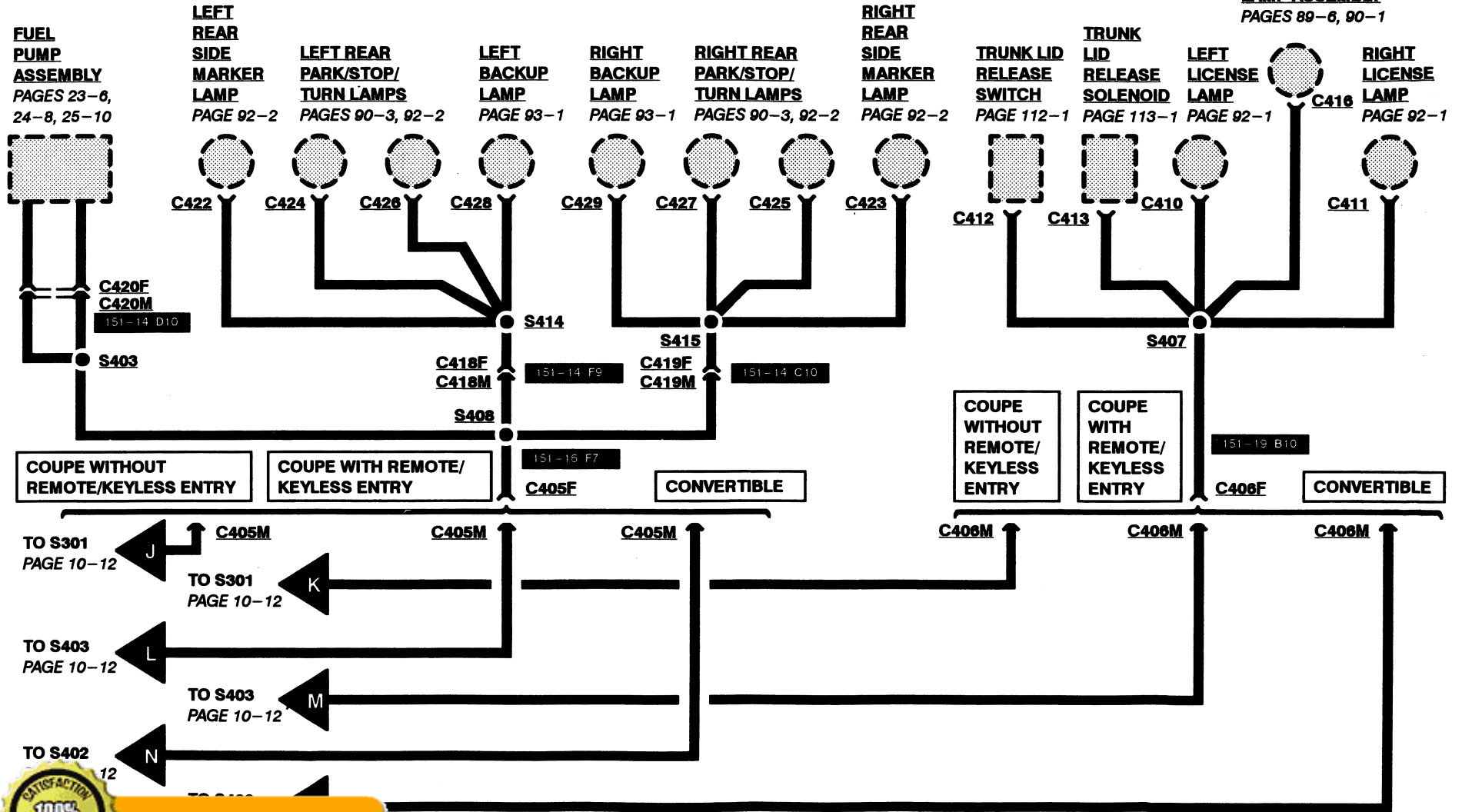

100% SATISFACTION GUARANTEED

BUY IT NOW!

Click Here To Order

PayPal, American Express, Discover, MasterCard, VISA

Refer to Location Index, Cell 152, for Component, Connector, Splice, Ground and Base Part Number descriptions and locations.

152-31 LOCATION INDEX

1998 MUSTANG

Connector	Location	Page Zone	Connector		
			Page	Color	Terminal
C505 (Convertible)	On master window/door lock control switch	151-17 D1	100-5	BK	16
C507 (Convertible)	In LH door, to left door disarm switch	151-18 E1	*	*	4
C507 (Coupe)	In LH door, to left door disarm switch	151-15 E1	*	*	4
C508 (Convertible)	On left courtesy lamp switch	151-18 A1	*	N	3
C508 (Coupe)	On left courtesy lamp switch	151-15 B1	*	N	3
C509 (Convertible)	On left door lock motor	151-17 E1	*	BK	2
C509 (Coupe)	On left door lock motor	151-14 E1	*	BK	2
C510 (Convertible)	In LH door, to left power mirror	151-17 B1	*	*	3
C510 (Coupe)	In LH door, to left power mirror	151-14 B1	*	*	3
C511 (Convertible)	On left front super sound speaker	151-18 B1	*	GY	2
C511 (Coupe)	On left front super sound speaker	151-15 B1	*	GY	2
C512 (Convertible)	On one touch down power window module	151-19 D1	*	*	5
C512 (Coupe)	On one touch down power window module	151-16 D1	*	*	6
C520	In LH door	*	*	BR	6
C602 (Coupe)	On right window/door lock control switch	151-14 A6	100-6	BK	10
C602 (Convertible)	On right window/door lock control switch	151-17 A6	100-6	BK	10
C603 (Convertible)	On right door speaker	151-18 A6	*	GY	2
C603 (Coupe)	On right door speaker	151-15 A5	*	GY	2
C604 (Convertible)	In RH door, to right door window motor	151-17 A4	*	*	2
C604 (Coupe)	In RH door, to right door window motor	151-14 A4	*	*	2
C607 (Convertible)	In RH door, to right door disarm switch	151-18 A7	*	N	2
C607 (Coupe)	In RH door, to right door disarm switch	151-15 A6	*	N	2
C608 (Convertible)	On right courtesy lamp switch	151-18 A4	*	N	3
C608 (Coupe)	On right courtesy lamp switch	151-15 A3	*	N	3
C609 (Convertible)	On right door lock motor	151-17 A7	*	BK	2
C609 (Coupe)	On right door lock motor	151-14 A7	*	BK	2
C610 (Convertible)	In RH door, to right power mirror	151-17 A5	*	*	3
C610 (Coupe)	In RH door, to right power mirror	151-14 A5	*	*	3
C611 (Convertible)	On right front super sound speaker	151-18 A5	*	GY	2
C611 (Coupe)	On right front super sound speaker	151-15 A4	*	GY	2
C900	On dome/map lamp	151-14 A2	*	*	3
C901	RH side of windshield header, to right vanity mirror lamp	151-17 A3	*	*	2
C902	LH side of windshield header, to left vanity mirror lamp	151-17 A1	*	*	2
C903	Center of windshield header, to dome/map lamp	151-17 A2	*	*	4

BUY IT NOW!
 Click Here To Order 







LOCATION INDEX 152-32

1998 MUSTANG

<u>Connector</u>	<u>Location</u>	<u>Page</u>	<u>Connector</u>			
		<u>Zone</u>	<u>Page</u>	<u>Color</u>	<u>Terminal</u>	
C904	RH side of windshield header, to right vanity mirror lamp	151-14	A3	★	N	2
C905	LH side of windshield header, to left vanity mirror lamp	151-14	A1	★	N	2
C1000 (4.6L) 2V	LH side of engine, ignition coil	151-9	E1	★	★	3
C1000 (4.6L) 4V	LH side of engine, ignition coil	151-5	F3	★	★	3
C1001 (4.6L) 2V	RH side of engine, ignition coil	151-9	F9	★	★	3
C1001 (4.6L) 4V	RH side of engine, ignition coil	151-5	F7	★	★	3
C1002	By evaporative emission (EVAP) canister purge valve	151-4	A3	★	★	4
C1003	On intake manifold runner control	151-4	A5	★	★	6
C1004	Near knock sensors	151-4	A4	★	★	4
C1005 (4.6L) 2V	Near engine oil pressure switch	151-8	C10	★	★	8
C1005 (4.6L) 4V	Near engine oil pressure switch	151-6	C10	★	★	8
C1006 (3.8L)	On integral generator regulator	151-1	A8	★	★	1
C1006 (4.6L)	On integral generator regulator	151-4	A6	★	★	1
C1111 (4.6L)	Top RH front of engine, to radio interference capacitor	151-4	F6	★	★	1

★ Not Available

<u>Ground</u>	<u>Location</u>	<u>Page</u>
		<u>Zone</u>
G101 (4.6L) 2V	Center rear of engine	151-9 A7
G102 (3.8L)	LH front of engine compartment	151-1 E10
G102 (4.6L) 2V	LH front of engine compartment	151-7 F8
G102 (4.6L) 4V	LH front of engine compartment	151-4 E10
G103 (3.8L)	RH front of engine compartment	151-2 E1
G103 (4.6L) 2V	RH front of engine compartment	151-8 E1
G103 (4.6L) 4V	RH front of engine compartment	151-5 F3
G104 (3.8L)	LH front of engine compartment	★
G104 (4.6L)	LH front of engine compartment	★
G105 (3.8L)	LH front of engine	★
G105 (4.6L) 2V	LH front of engine	151-8 F5
G105 (4.6L) 4V	LH front of engine	151-6 F7
G201	Behind I/P, at RH cowl	151-11 F8
G203	Behind center of I/P	151-12 F2
	Behind center of I/P	151-12 F3
	Behind center of I/P	151-12 F3
	Below rear of center console	151-19 E1
	Below rear of center console	151-16 E1
G	RH front of trunk	151-18 A10
G	RH rear window pillar	151-15 A9

★ Not Available

100% GUARANTEED

BUY IT NOW!

Click Here To Order

PayPal American Express Discover MasterCard VISA

152-33 LOCATION INDEX

1998 MUSTANG

<u>Splice</u>	<u>Location</u>
S100	Engine control sensor harness, near T/O to C145
S101	Body main harness, near T/O to C107
S102	Engine control sensor harness, near T/O to C189
S103	Dash panel to headlamp junction harness, near T/O to G102
S104	Dash panel to headlamp junction harness, near T/O to G103
S105	Engine control sensor harness, near T/O to C145
S106	Dash panel to headlamp junction harness, near T/O to C120
S107	Engine control harness, near T/O to C104
S108	Engine control sensor harness, near T/O to C108
S109	Dash panel to headlamp junction harness, near T/O to C100
S110	Dash panel to headlamp junction harness, near T/O to C124
S111	Dash panel to headlamp junction harness, in T/O to engine compartment fuse box
S112	Engine control harness, near T/O to C104
S115	Engine control sensor harness, near T/O to C145
S116	Engine control sensor harness, near T/O to C145
S119	Engine control sensor harness, near T/O to C128
S121	Engine control sensor harness, near grommet
S122 (3.8L)	Engine control sensor harness, in T/O to C173
S122 (4.6L)	Engine control sensor harness, near T/O to C128
S123 (3.8L)	Fuel charge harness, near T/O to C185
S123 (4.6L)	Engine control harness, near T/O to C104
S124	Fuel charge harness, near T/O to C182
S125 (4R70W Transmission)	Transmission control selector neutral switch harness, near T/O to C132
S125 (T5OD Transmission)	Back up lamp switch to rear lamp feed harness, near T/O to C196
S125 (T45 Transmission)	Back up lamp switch to rear lamp feed harness, near T/O to C196
S126 (T45 Transmission)	Back up lamp switch to rear lamp feed harness, near T/O to C196
S126 (4R70W Transmission)	Transmission control selector neutral switch harness, near T/O to C132
S126 (T5OD Transmission)	Back up lamp switch to rear lamp feed harness, near T/O to C119
S127	Engine control sensor harness, near grommet
S129 (3.8L)	Fuel charge harness, near T/O to C180
S129 (4.6L)	Engine control harness, near T/O to C180
S130 (3.8L)	Fuel charge harness, near T/O to C186
S131 (3.8L)	Engine control harness, near T/O to C179
S132 (3.8L)	Dash panel to headlamp junction harness, near T/O to C112
S133 (3.8L)	Fuel charge harness, near T/O to C137
S134 (3.8L)	Dash panel to headlamp junction harness, near T/O to C112
S135 (3.8L)	Dash panel to headlamp junction harness, near T/O to C112
S136 (3.8L)	Dash panel to headlamp junction harness, near T/O to C127



BUY IT NOW!

Click Here To Order



<u>Splice</u>	<u>Location</u>
S137	Engine oil pressure & engine coolant temperature indicator sender harness, near T/O to C131
S138	Engine oil pressure & engine coolant temperature indicator sender harness, near T/O to C131
S139	Engine control sensor extension harness, near T/O to C168
S140	Engine control sensor harness, near T/O to C128
S142	Fuel charge harness, between T/O to C186 and T/O to C177
S143 (3.8L)	Fuel charge harness, near T/O to C195
S143 (4.6L)	Engine control harness, near T/O to C104
S144	Engine control sensor harness, near T/O to C130
S145	Engine control sensor harness, near T/O to C152
S149 (4.6L 2V)	Engine control harness, near T/O to C104
S149 (4.6L 4V)	Engine control harness, in T/O to C1003
S150	Engine control harness, near T/O to C188
S151	Engine control harness, near T/O to C165
S152	Engine control harness, near T/O to C182
S153	Engine control harness, near T/O to C160
S154	Engine control sensor harness, near T/O to C152
S155	Engine control sensor harness, near T/O to C152
S162	Engine control harness, near T/O to C179
S163	Engine control harness, near T/O to C186
S168	Engine control sensor extension harness, near T/O to C1005
S200	Engine control sensor harness, near T/O to C259
S201	Main harness, near T/O to G203 & G204
S203	Main harness, near T/O to C232
S204	Engine control sensor harness, near T/O to C259
S205	Main harness, near T/O to C228
S206	Main harness, near T/O to C228
S207	Body main harness, near T/O to C259
S208	Radio amplifier harness, in T/O to C257
S209	Radio amplifier harness, near T/O to C280
S210	Main harness, near T/O to C210
S212	Radio amplifier harness, near T/O to C252
S213	Main harness, near T/O to C237
	Main harness, near T/O to C228
	Main harness, near T/O to C209
	Main harness, near T/O to C209
	Main harness, near T/O to C226
	Body main harness, near T/O to C212
	Main harness, near T/O to C288

100% SATISFACTION GUARANTEED

BUY IT NOW!

Click Here To Order

PayPal American Express Discover MasterCard VISA

152-35 LOCATION INDEX

1998 MUSTANG

<u>Splice</u>	<u>Location</u>
S221	Main harness, near T/O to C299
S222	Radio amplifier harness, near T/O to C280
S223	Body main harness, near T/O to C253
S224	Main harness, near T/O to C246
S225	Main harness, in T/O to C211
S226	Main harness, in T/O to C226
S227	Main harness, near T/O to C246
S228	Main harness, in T/O to C250
S229	Main harness, near T/O to C226
S230	Main harness, near T/O to C220
S231	Main harness, near T/O to C299
S232	Body main harness, near T/O to C260
S233	Main harness, near T/O to C210
S234	Engine control sensor harness, behind RH side of I/P, near grommet
S235	Engine control sensor harness, in T/O to C213 & C216
S237	Body main harness, near T/O to C227
S238	Radio amplifier harness, near T/O to C258
S240	Engine control sensor harness, near grommet
S241	Main harness, in T/O to C240 & C241
S244	Engine control sensor harness, near T/O to C294
S246	Body main harness, near T/O to C255
S247	Main harness, in T/O to C250
S248	Main harness, near T/O to C250
S249	Body main harness, near T/O to C229
S250	Engine control sensor harness, behind RH side of I/P, near grommet
S251	Engine control sensor harness, T/O to C259
S252	Main harness, near T/O to C232
S253	Main harness, near T/O to C232
S254	Main harness, near T/O to C210
S255	Main harness, near T/O to C232
S301	Body main harness, near T/O to C300
S302	Body main harness, near T/O to C301
S303	Console panel harness, near T/O to C309
S304	Console panel harness, in T/O to C305
S305	Body main harness, near T/O to C212
S306	Lumbar harness, below LH front seat
S307	Body main harness, near T/O to C444
S308	Body main harness, near T/O to C320



BUY IT NOW!

Click Here To Order



<u>Splice</u>	<u>Location</u>
S316	Body main harness, near T/O to C304
S317	Body main harness, near T/O to C319
S319	Body main harness, near T/O to C320
S320	Body main harness, near T/O to C212
S401	Body main harness, near T/O to C406
S402	Body main harness, near T/O to C406 & C432
S403	Body main harness, near T/O to C445
S404	Radio amplifier harness, near T/O to C409
S405	Radio amplifier harness, near T/O to C408
S407	Luggage compartment lamp harness, near T/O to C421
S408	Rear lamp harness, near T/O to C420
S409	Near T/O to convertible top motor C438
S410	Body main harness, near T/O to C405
S411	Body main harness, near T/O to C445
S412	Body main harness, in T/O to C404
S413	Body main harness, in T/O to C402
S414	LH rear lamp harness, near T/O to C426
S415	RH rear lamp harness, near T/O to C425
S416	Body main harness, in T/O to C405
S417	Luggage compartment lamp harness, near T/O to C421
S418	Rear lamp harness, in T/O to C405
S419	RH rear lamp harness, near T/O to C427
S420	LH rear lamp harness, near T/O to C424
S423	Body main harness, in T/O to C405
S424	Body main harness, in T/O to C400
S425	Rear lamp harness, near T/O to C418
S426	Body main harness, near T/O to C406
S427	Body main harness, in T/O to C403 & C404
S428	Body main harness, in T/O to C400
S429	Body main harness, in T/O to C401
S430	Body main harness, in T/O to C401
S431	Radio amplifier harness, near T/O to C441
	Radio amplifier harness, near T/O to C408
	Radio amplifier harness, near T/O to C409
	Radio amplifier harness, near T/O to C441
	Radio amplifier harness, near T/O to C325
	Radio amplifier harness, near T/O to C441
	Radio amplifier harness, near T/O to C325



BUY IT NOW!

Click Here To Order 







152-37 LOCATION INDEX

1998 MUSTANG

<u>Splice</u>	<u>Location</u>
S437	Radio amplifier harness, near T/O to C325
S501	LH door window regulator harness, near T/O to C504
S502	LH door window regulator harness, near T/O to C509
S503	LH door window regulator harness, near T/O to C503
S504	LH door window regulator harness, near T/O to C503
S505 (Convertible)	LH door window regulator harness, near T/O to C503
S505 (Coupe)	LH door window regulator harness, near T/O to C501
S506	LH door window regulator harness, near T/O to C511
S510	LH door window regulator harness, near T/O to C501
S602	RH door window regulator harness, near T/O to C611
S603	RH door window regulator harness, near T/O to C611
S901 (Convertible)	Interior lamp feed harness, near T/O to C901
S901 (Coupe)	Interior lamp harness, near T/O to C900
S902 (Convertible)	Interior lamp feed harness, near T/O to C903
S902 (Coupe)	Interior lamp harness, near T/O to C900

SATISFACTION 100% GUARANTEED

BUY IT NOW!

Click Here To Order

PayPal American Express Discover MasterCard VISA

SATISFACTION 100% GUARANTEED

BUY IT NOW!

[Click Here To Order](#)

PayPal Discover MasterCard VISA



**TECHNICAL
SUPPORT OPERATIONS**

Ford Customer Service Division

100% SATISFACTION GUARANTEED

BUY IT NOW!

Click Here To Order 

LITHO IN U.S.A.
AD-312



FCS-12121-98

COPYRIGHT © 1997
FORD MOTOR COMPANY