



# 1996 BRONCO

[Buy Now](#)

FIX IT RIGHT THE FIRST TIME ON TIME



## DEMO

This DEMO contains only a few pages of the entire manual/product.

Not all Bookmarks work on the Demo, but they do on the full version.

### Features:

- Searchable text
- Printable pages
- Bookmarked for easy navigation
- High Resolution images
- Zoom to see exact details
- Money back Guarantee
- Available on USB and eBook download



License #84356800

Copyright © 2024, Forel Publishing Company, LLC, Woodbridge, Virginia

All Rights Reserved. No part of this book may be used or reproduced in any manner whatsoever without written permission of Forel Publishing Company, LLC. For information write to Forel Publishing Company, LLC, Woodbridge, VA 22192

**1996 Bronco Electrical & Vacuum  
Trouble-Shooting Manual (EVTM)  
EAN: 978-1-60371-418-1  
ISBN: 1-60371-418-9**

Forel Publishing Company, LLC  
Woodbridge, VA 22192  
Email: [sales@ForelPublishing.com](mailto:sales@ForelPublishing.com)  
<https://www.ForelPublishing.com>



This publication contains material that is reproduced and distributed under a license from Ford Motor Company. No further reproduction or distribution of the Ford Motor Company material is allowed without the express written permission of Ford Motor Company.

---

## Note from the Publisher

This product was created from the original Ford Motor Company's publication. Every effort has been made to use the original scanned images, however, due to the condition of the material; some pages have been modified to remove imperfections.

---

## Disclaimer

Although every effort was made to ensure the accuracy of this book, no representations or warranties of any kind are made concerning the accuracy, completeness or suitability of the information, either expressed or implied. As a result, the information contained within this book should be used as general information only. The author and Forel Publishing Company, LLC shall have neither liability nor responsibility to any person or entity with respect to any loss or damage caused, or alleged to be caused, directly or indirectly by the information contained in this book. Further, the publisher and author are not engaged in rendering legal or other professional services. If legal, mechanical, electrical, or other expert assistance is required, the professional should be sought.



# We Want To Hear From You!

Your suggestions will help us to improve this manual.  
Mail this form or fax your comments to:  
(313) 390-8727

Manual \_\_\_\_\_ Vehicle \_\_\_\_\_ Year \_\_\_\_\_

Did you find any errors in the procedures or illustrations?

YES	NO
<input type="checkbox"/>	<input type="checkbox"/>

If yes, page \_\_\_\_\_ please describe in detail: \_\_\_\_\_  
\_\_\_\_\_  
\_\_\_\_\_

Did the procedures make sense and were they easy to follow?

YES	NO
<input type="checkbox"/>	<input type="checkbox"/>

If no, page \_\_\_\_\_ please describe: \_\_\_\_\_  
\_\_\_\_\_  
\_\_\_\_\_

Is the organization of the manual clear and easy to follow?

YES	NO
<input type="checkbox"/>	<input type="checkbox"/>

Please comment: \_\_\_\_\_  
\_\_\_\_\_  
\_\_\_\_\_

Are there any important procedures not covered in this manual that  
you would like to see included?

YES	NO
<input type="checkbox"/>	<input type="checkbox"/>

If yes, please describe: \_\_\_\_\_  
\_\_\_\_\_  
\_\_\_\_\_

Please enclose a copy of each page marked with your suggestions.

Please tell us who you are:

Name \_\_\_\_\_

Street \_\_\_\_\_

City \_\_\_\_\_ State \_\_\_\_\_ Zip \_\_\_\_\_

Company \_\_\_\_\_



**BUY IT NOW!**

**Click Here To Order**



DO NOT STAPLE — USE TRANSPARENT TAPE

---



NO POSTAGE  
NECESSARY  
IF MAILED  
IN THE  
UNITED STATES

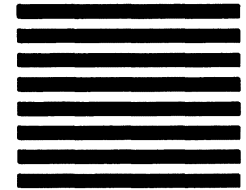

**BUSINESS REPLY MAIL**  
FIRST CLASS PERMIT NO. 400 DEARBORN, MICH.

POSTAGE WILL BE PAID BY ADDRESSEE

Technical Service Publications  
EVTM  
P.O. Box 2592  
Dearborn, MI 48121-9973



**100% SATISFACTION GUARANTEED**

**BUY IT NOW!**

**Click Here To Order**

PayPal    American Express    Discover    MasterCard    VISA

# ELECTRICAL AND VACUUM TROUBLESHOOTING MANUAL

## FCS-12129-96

### FORD CUSTOMER SERVICE DIVISION

## Quality is Job 1

Ford Customer Service Division has continued with the existing format for the 1996 BRONCO EVTVM. Our goal is to provide accurate and timely electrical and vacuum service information.

### 1996 EVTVM FEATURES

- Schematic pages now contain **Component Location** references to full-view illustrations and **Component Descriptions** that describe the system function of a component.
- **“COMPONENT TESTING”** procedures (CELL 149) that tell the user how to perform diagnostic tests on various circuits.
- **Connector End Views** are located at the end of individual cells and are shown for connectors with five or more cavities, for connectors with ten or more cavities, a circuit function chart is provided.
- **NOTES, CAUTIONS and WARNINGS** that contain important safety information.
- Full view **“COMPONENT LOCATION VIEWS”** (CELL 151) to help locate on-vehicle components.
- Circuit voltages are included on schematic pages to help simplify troubleshooting.
- **Cellular Pagination:** A specific section (or cell) in all EVTVMs is numbered by cell and starts with page 1. For example: **“HOW TO USE THIS MANUAL”** is CELL 2 and begins with page 2-1.
- **“IN-LINE CONNECTOR FACES”** (CELL150) are included for in-line connectors with six or more terminals, to aid in servicing electrical wiring.
- **“C”** numbers are assigned for all electrical connectors. **“C”** numbers are listed in the **“LOCATION INDEX”** (CELL 152).
- **“HARNESS CAUSAL PART NUMBERS”** (CELL153) are included to aid in identifying

**“T NUMBERS”** contain a suffix to denote connector “gender” type

### ORDERING INFORMATION

Information about how to order additional copies of this publication or other Ford publications may be obtained by writing to Helm Incorporated at the address shown below or by calling 1-800-782-4356. Other publications available include:

- Service Manuals
- Service Specification Books
- Car/Truck Wiring Diagrams
- Powertrain Control/Emissions Diagnosis Manuals

Helm Incorporated  
P.O. Box 07150  
Detroit, Michigan 48207



# 1-1 TABLE OF CONTENTS/INDEX

1996 BRONCO

## Table Of Contents

How to Use This Manual	2-1
Grounds	10-1
Fuse Panel/Circuit Protection	11-1
Charging System	12-1
Power Distribution	13-1
Starting System	20-1
Ignition System	21-1
Engine Controls (5.0L)	24-1
Engine Controls (5.8L)	25-1
Transmission Controls (4R70W)	29-1
Transmission Controls (E40D)	30-1
Speed Control	31-1
All-Wheel Drive	34-1
Shift Lock	37-1
Anti-Lock Brakes	42-1
Horn/Cigar Lighter	44-1
Air Bags	46-1
Heater	53-1
Air Conditioner/Heater	54-1
Rear Window Defroster	56-1
Instrument Cluster	60-1
Vehicle Speed Sensor	64-1
Warning Chime	66-1
Instrument Illumination	71-1
Interval Wiper/Washer	81-1
Headlamps	85-1
Courtesy Lamps	89-1
Turn/Stop/Hazard Lamps	90-1
Exterior Lamps	92-1
Backup Lamps	93-1
Trailer/Camper Adapter	95-1
Daytime Running Lamps (DRL)	97-1
Power Windows	100-1
Overhead Console	102-1
Power Door Locks	110-1
Remote/Keyless Entry	111-1
Seat Belt Pre-tensioner Seats	122-1
Interior Lamps	125-1
Power Windows	130-1
Overhead Console	140-1
Power Door Locks	149-1

In-Line Connector Faces	150-1
Component Location Views	151-1
Location Index	152-1
Harness Causal Part Number	153-1
Vehicle Repair Location Codes	160-1

## Index

4R70W Transmission	29-1
Air Bags	46-1
All-Wheel Drive:	
Electronic	34-1
Air Conditioner/Heater:	
Vacuum	54-1
Electrical	54-2
Anti-Lock Brakes	42-1
Automatic Day/Night Mirror	125-1
Charging System	12-1
Cigar Lighter	44-1
Fuse Panel/Circuit Protection	11-1
Component Testing:	
A/C-Heater Control Assembly	149-7
Blower Motor Switch	149-8
Heater Function Selector Switch	149-6
Ignition Switch	149-2
Introduction	149-1
Main Light Switch	149-1
Multi-function Switch	149-3 to 149-5
Engine Controls	
5.0L	24-1
5.8L	25-1
Courtesy Lamps	89-1
Daytime Running Lamps	97-1
E40D Transmission	30-1
Engine Compartment Fuse Box	13-1
5.0L	24-1
5.8L	25-1
Fuse Panel:	
Fuse 1	13-10
Fuse 2	13-14
Fuse 4	13-13

Fuse 5	13-7
Fuse 6	13-14
Fuse 7	13-10
Fuse 8	13-12
Fuse 9	13-7
Fuse 10	13-15
Fuse 11	13-14
C.B. 12	13-8
Fuse 13	13-7
C.B. 14	13-14
Fuse 16	13-8
Fuse 17	13-11
Fuse 18	13-10
Gauges:	
Coolant Temperature	60-2
Engine Oil Pressure	60-2
Fuel	60-1
Tachometer	60-5
Voltmeter	60-1
Grounds:	
G100	10-1, 10-11
G101	10-2
G103	10-2
G104	10-11
G200	10-5
G201	10-6
G400	56-1
G401	95-3
Headlamps	85-1
Heater	53-1
Horn	44-1
Ignition Switch	13-3
Ignition System	21-1
Indicators:	
4 x 4	60-3
Air Bags	60-3
Anti-lock Brake	42-3, 60-3
Charge	12-1, 60-4

**100% SATISFACTION GUARANTEED**

**BUY IT NOW!**

Click Here To Order

PayPal Discover MasterCard VISA

# TABLE OF CONTENTS/INDEX 1-2

1996 BRONCO

Fasten Seat Belt .....	60-4, 66-1	Starting System .....	20-1
Hi Beam .....	60-4, 85-2	Trailer/Camper Adapter .....	95-1
Low Range .....	60-3	Vacuum Distribution .....	140-1
Malfunction:		Vehicle Speed Sensor .....	64-1
5.0L .....	24-7, 60-3	Warning Chime .....	66-1
5.8L .....	25-5, 60-3	Windows:	
Turn .....	60-4, 90-1	Cab .....	100-1
Instrument Cluster .....	60-1	Tailgate .....	100-2
Instrument Illumination .....	71-1	Wiper/Washer (Interval) .....	81-1
Interval Wiper/Washer .....	81-1		
Lamps (Exterior):			
Backup .....	93-2		
Engine Compartment ....	89-7, 92-3, 111-7		
Hazard .....	90-1		
License .....	92-2		
Marker .....	92-1		
Park .....	92-2		
Stop .....	90-3		
Turn:			
Front .....	90-1		
Rear .....	90-3		
Lamps (Interior):			
Glove Compartment .....	89-7, 111-7		
Dome/Map/Cargo .....	89-2, 89-5		
Courtesy Lamps .....	89-1		
Main Light Switch .....	13-15		
Power Distribution .....	13-1		
Door Locks .....	110-1		
Lumbar Seats:			
Captain's Chairs .....	122-1		
Mirrors .....	124-1		
Overhead Console .....	102-1		
Programmable Speedometer/ Odometer Module .....	60-7, 64-1		
Radio .....	130-1		
.....	56-1		
.....	111-1		
.....	37-1		
.....	31-1, 31-2		

## IMPORTANT SAFETY NOTICE

*Appropriate service methods and proper repair procedures are essential for the safe, reliable operation of all motor vehicles, as well as the personal safety of the individual doing the work. This Manual provides general directions for accomplishing service and repair work with tested, effective techniques. Following them will help assure reliability.*

*There are numerous variations in procedures, techniques, tools, and parts for servicing vehicles, as well as in the skill of the individual doing the work. This Manual cannot possibly anticipate all such variations and provide advice or cautions as to each. Accordingly, anyone who departs from the instructions provided in this Manual must first establish that neither personal safety nor the vehicle integrity be compromised by the choice of methods, tools or parts.*



# 2-1 HOW TO USE THIS MANUAL

1996 BRONCO

The purpose of this manual is to show electrical and vacuum circuits in a clear and simple fashion to make troubleshooting easier. **NOTES**, **CAUTIONS** and **WARNINGS** contain important information.

- **NOTES** describe how switches and other components operate to help complete a particular procedure.
- **CAUTIONS** provide information that could prevent making an error that may damage the vehicle.
- **WARNINGS** provide information to prevent personal injury.

The **WARNINGS** list on page 2-2 contains general warnings to follow when servicing a vehicle.

Components that work together are shown together. All electrical components used in a specific system are shown on one diagram. The circuit breaker or fuse is shown at the top of the page. All wires, connectors, components and splices are shown in the flow of current to ground at the bottom of the page. If a component is used in several different systems, it is shown in several places. For example, the Main Light Switch is electrically a part of many systems and is repeated on many pages.

In some cases, a component may seem (by its name) to belong to a system where it has no electrical connection. For example, Radio Illumination is electrically part of Instrument Illumination, but because it has no electrical connection to the Radio system, it is not shown on

text blocks located next to each component and connector and refer the user to the appropriate illustration page and zone. The description notes describe the operation of the component.

Schematic pages contain circuit voltages to help simplify troubleshooting hints. 12V is used to imply battery voltage on a component connector terminal, and 0V is used to show that there should be continuity to ground on that particular terminal. Conditional voltages such as "12V with the ignition switch in RUN" will also be provided. Troubleshooting hints that can't be simplified with circuit voltages will be shown at the end of each cell.

Component connector face information specific to a certain cell is found at the end of that cell. A Connector Face Reference List is provided to locate connector faces that are shown in different cells. Component connectors with five or more terminals are illustrated and are accompanied by a pinout chart that lists the function of all circuitry associated with that component.

**"GROUNDS"** (Cell 10) contains ground circuitry shown in complete detail. This information is useful for checking interconnections of the ground circuits of different systems.

**"POWER DISTRIBUTION"** (Cell 13) contains power distribution circuitry shown in complete detail. This section displays how the various fuses are powered and, in turn, how each system is powered.

**"COMPONENT TESTING"** (Cell 149) contains testing procedures for various switches. This information includes schematics, component terminal locations and step-by-step procedures.

**"IN-LINE CONNECTOR FACES"** (Cell 150) contains illustrations of all the in-line connectors that have 6 or more terminals. The terminals have pin numbers assigned to them.

**"COMPONENT LOCATION VIEWS"** (Cell 151) contains full-view illustrations which show the location of all components and connectors in the vehicle.

The **"LOCATION INDEX"** (Cell 152) provides the base part numbers, locations, connector face references and illustration references for all components, connectors, splices and grounds.

## HELPFUL REMINDERS

Before using the EVTM for troubleshooting, refer to these HELPFUL REMINDERS:

1. The abbreviation T/O, for take out, used in the Location Index (Cell 152), refers to the point at which a group of wires branch off the harness trunk. Refer to the wiring harness illustration.

SATISFACTION  
100%  
GUARANTEED

**BUY IT NOW!**

Click Here To Order

to full-  
or vari-  
erse-

PayPal American Express Discover MasterCard VISA

Wiring harness at back of Instrument Panel, showing typical T/O (Take Out) locations

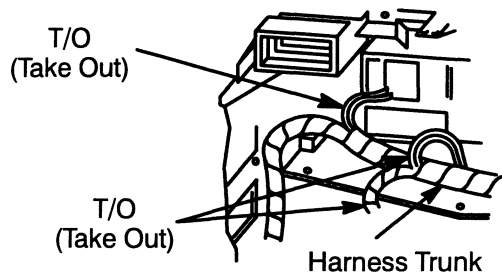

- If a connector serves the same purpose in two separate versions (e.g., Automatic/Manual), but is physically different, two connector numbers are used. However, if a connector serves the same purpose in two separate versions (e.g., Automatic/Manual) and is physically the same, but the wire colors are different, only *one* connector number is used. If the same physical connector is used more than once, then more than *one* connector number is used.
- Wiring schematics provide a picture of how and under what conditions the circuit is powered, of the current path to circuit components, and of how a circuit is grounded. Each circuit component is named (underlined titles). Wire and connector colors are listed as follows (standard Ford color abbreviations are used):

## COLOR ABBREVIATIONS

BL	Blue	N	Natural
BK	Black	O	Orange
BR	Brown	PK	Pink
DB	Dark Blue	P	Purple
DG	Dark Green	R	Red
GN	Green	T	Tan
GY	Gray	W	White
LB	Light Blue	Y	Yellow
LG	Light Green		

**Note:** Whenever a wire is labeled with two colors, the first color listed is the basic color of the wire, and the second color listed is the stripe marking of the wire.

- When reporting Vehicle Repair Location Codes to Ford Customer Service Division, refer to Cell 160 (beginning on page 160-1). Note: Do *not* use the illustrations in Cell 151 (beginning on page 151-1) for reporting Vehicle Repair Location Codes.

## 5. WARNINGS

- Always wear safety glasses for eye protection.
- Use safety stands whenever a procedure requires being under a vehicle.
- Be sure that the Ignition Switch is always in the OFF position, unless otherwise required by the procedure.
- Set the parking brake when working on any vehicle. An automatic transmission should be in PARK. A manual transmission should be in NEUTRAL.
- Operate the engine only in a well-ventilated area to avoid danger of carbon monoxide.

- Keep away from moving parts, especially the fan and belts, when the engine is running.
- To prevent serious burns, avoid contact with hot metal parts such as the radiator, exhaust manifold, tail pipe, catalytic converter and muffler.
- Do not allow flame or sparks near the battery. Gases are always present in and around the battery cell. An explosion could occur.
- Do not smoke when working on a vehicle.
- To avoid injury, always remove rings, watches, loose hanging jewelry and avoid wearing loose clothing.

## HOW TO FIND ELECTRICAL CONCERNS

### TROUBLESHOOTING STEPS

These six steps present an orderly method of troubleshooting.

#### Step 1. Verify the concern.

- Operate the complete system to check the accuracy and completeness of the customer's complaint.

#### Step 2. Narrow the concern.

- Using the EVTM, narrow down the possible causes and locations of the concern to pinpoint the exact cause.
- Read the description notes at the components and study the wiring schematic. You should then know enough about the circuit operation to determine where to check for the trouble. Further information can be found by referring to the Service Manual pages listed in the box at the top of the page.

100% SATISFACTION GUARANTEED

**BUY IT NOW!**

Click Here To Order

# 2-3 HOW TO USE THIS MANUAL

1996 BRONCO

## Step 3. Test the suspected cause.

- Use electrical test procedures to find the specific cause of the symptoms.
- The component location reference bars and the pictures will help you find components. The Location Index (at the end of the manual) gives component location information for connectors, diodes, resistors, splices and grounds.

## Step 4. Verify the cause.

- Confirm that you have found the correct cause by connecting jumper wires and/or temporarily installing a known good component and operating the circuit.

## Step 5. Make the repair.

- Repair or replace the inoperative component.

## Step 6. Verify the repair.

- Operate the system as in Step 1 and check that your repair has removed all symptoms without creating any new symptoms.

Some engine circuits may need special test equipment and special procedures. See the *Service Manual* and other service books for details. You will find the circuits in this manual to be helpful with those special test procedures.

## TROUBLESHOOTING TOOLS

### JUMPER WIRE

This is a test lead used to connect two points of a circuit. A Jumper Wire can bypass an open or short in a circuit.

**100% SATISFACTION GUARANTEED**

**BUY IT NOW!**

**Click Here To Order**

PayPal Discover/Novus MasterCard VISA

**WARNING**

*Never use a jumper wire across loads (motors, etc.) connected between hot and ground. This direct battery short may cause injury or fire.*

### VOLTMETER

A DC Voltmeter measures circuit voltage. Connect negative (- or black) lead to ground, and positive (+ or red) lead to voltage measuring point.

### OHMMETER

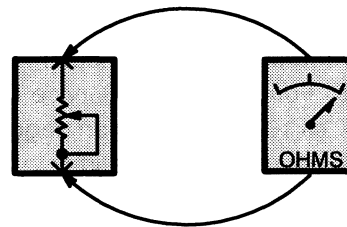

Figure 1 – Resistance Check

An Ohmmeter shows the resistance between two connected points (Figure 1).

### TEST LAMP

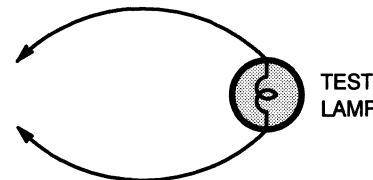

Figure 2 – Test Lamp

A Test Light is a 12-volt bulb with two test leads (Figure 2).

Uses: Voltage Check, Short Check.

### SELF-POWERED TEST LAMP

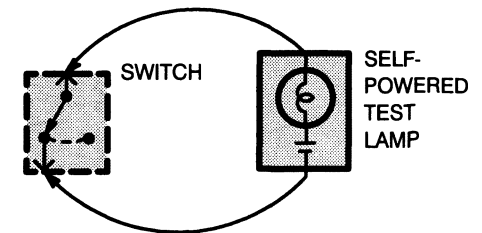

Figure 3 – Continuity Check

The Self-Powered Test Lamp is a bulb, battery and set of test leads wired in series (Figure 3). When connected to two points of a continuous circuit, the bulb glows.

Uses: Continuity Check, Ground Check.

**CAUTION**

*When using a self-powered test lamp or ohmmeter, be sure power is off in circuit during testing. Hot circuits can cause equipment damage and false readings.*

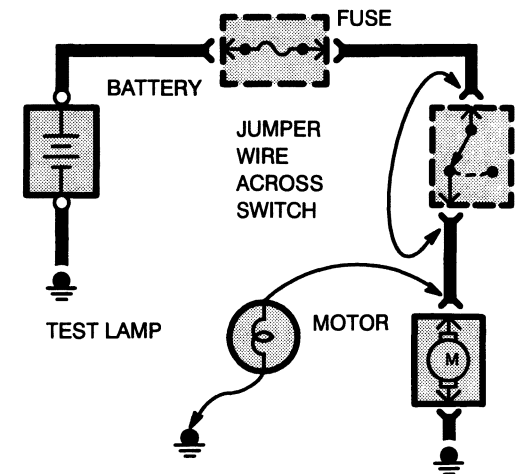

Figure 4 – Switch Circuit Check and Voltage Check

In an inoperative circuit with a switch in series with the load, jumper the terminals of the switch to power the load. If jumpering the terminals powers the circuit, the switch is inoperative (Figure 4).

## CONTINUITY CHECK (Locating open circuits)

Connect one lead of Self-Powered Test Lamp or Ohmmeter to each end of circuit (Figure 3). Lamp will glow if circuit is closed. Switches and fuses can be checked in the same way.

## VOLTAGE CHECK

Connect one lead of test lamp to a known good ground or the negative (-) battery terminal. Test for voltage by touching the other lead to the test point. Bulb goes on when the test point has voltage (Figure 4).

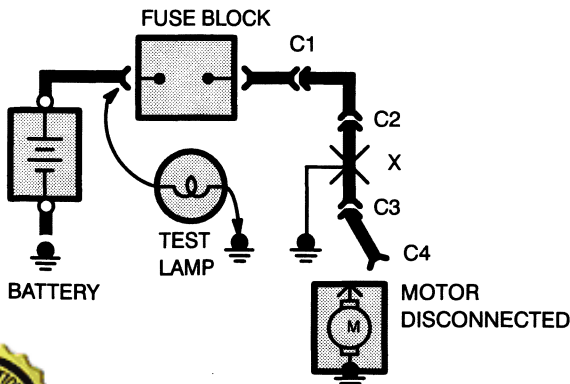

A fuse that repeatedly blows is usually caused by a short to ground. It's important to be able to locate such a short quickly (Figure 5).

1. Turn off everything powered through the fuse.
2. Disconnect other loads powered through the fuse:
  - Motors: disconnect motor connector (Connector C4 in Figure 5).
  - Lights: remove bulbs.
3. Turn Ignition Switch to RUN (if necessary) to power fuse.
4. Connect one Test Lamp lead to hot end of blown fuse. Connect other lead to ground. Bulb should glow, showing power to fuse. (*This step is just a check to be sure you have power to the circuit.*)
5. Disconnect the test lamp lead that is connected to ground, and reconnect it to the load side of the fuse at the connector of the disconnected component. (In Figure 5, connect the test lamp lead to connector C4.)
  - If the Test Lamp is off, the short is in the disconnected component.
  - If the Test Lamp goes on, the short is in the wiring. You must find the short by disconnecting the circuit connectors, one at a time, until the Test Lamp goes out. For example, in Figure 5 with a ground at X, the bulb goes out when C1 or C2 is disconnected, but not after disconnecting C3. This means the short is between C2 and C3.

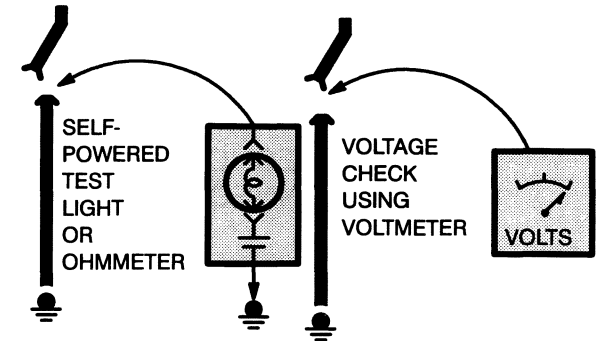

**Figure 6—Ground Check**

Turn on power to the circuit. Perform a Voltage Check between the suspected inoperative ground and the frame. Any indicated voltage means that the ground is inoperative (Figure 6).

Turn off power to the circuit. Connect one lead of a Self-Powered Test Lamp or Ohmmeter to the wire in question and the other lead to a known ground. If the bulb glows, the circuit ground is OK (Figure 6).

The circuit schematics in this manual make it easy to identify common points in circuits. This knowledge can help narrow the concern to a specific area. For example, if several circuits fail at the same time, check for a common power or ground connection (see *Power Distribution* or *Grounds*). If part of a circuit fails, check the connections between the part that works and the part that doesn't work.

For example, if the lo beam headlights work, but the high beams and the indicator lamp don't work, then power and ground paths must be good. Since the dimmer switch is the component that switches this power to the high beam lights and indicator, it is most likely the cause of failure.

**100% SATISFACTION GUARANTEED**

**BUY IT NOW!**

**Click Here To Order**

PayPal, American Express, Discover, MasterCard, VISA

# 2-5 HOW TO USE THIS MANUAL

1996 BRONCO

## TROUBLESHOOTING WIRING HARNESS AND CONNECTOR HIDDEN CONCERNS

The following illustrations are known examples of wiring harness, splices and connectors that will create intermittent electrical concerns. The concerns are hidden and can only be discovered by a physical evaluation as shown in each illustration.

**NOTE: When servicing gold plated terminals in a connector, only replace with the gold plated terminals designed for that connector.**

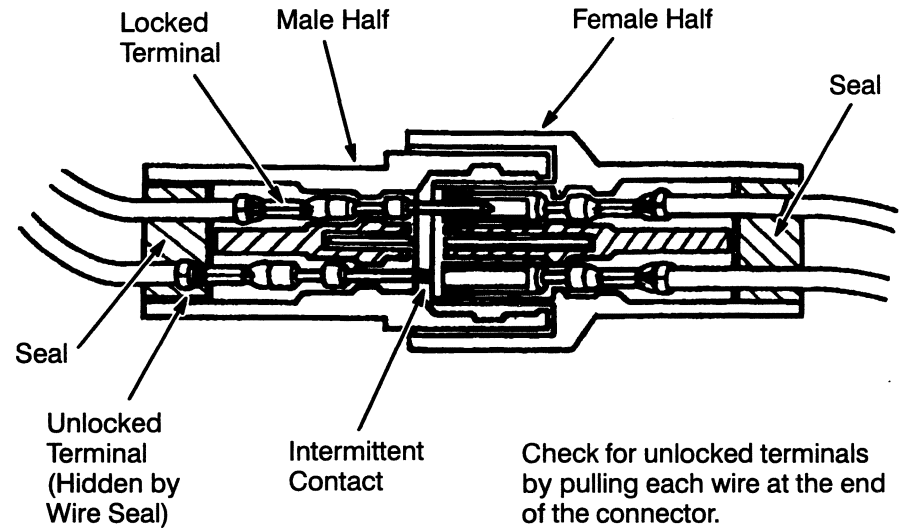

### TERMINAL NOT PROPERLY SEATED

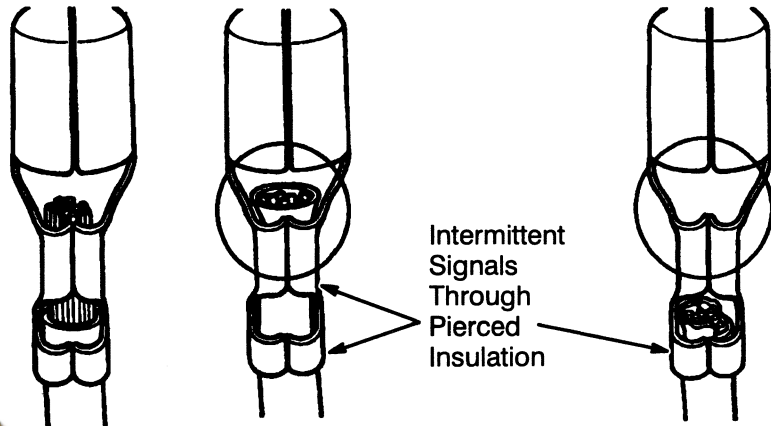

**100% SATISFACTION GUARANTEED**

**BUY IT NOW!**

**Click Here To Order**

PayPal, American Express, Discover, MasterCard, VISA

### TERMINAL STRIPPING

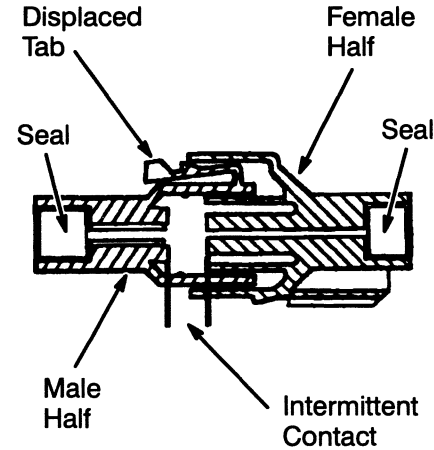

Lock may be displaced into an unlocked position; pull on the connector to verify the lock.

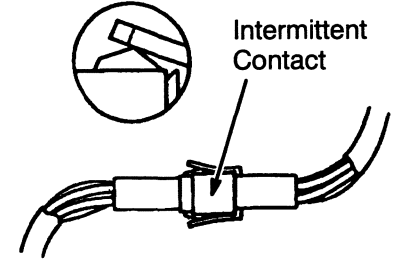

Type A

Type B

### PARTIALLY MATED CONNECTORS

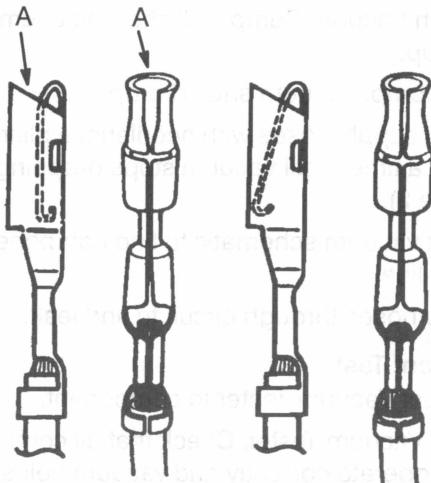

Enlarged

Normal

Any probe entering the terminal may enlarge the contact spring opening creating an intermittent signal. Insert the correct mating terminal (Location A) from the service kit and feel for a loose fit.

## DEFORMED (ENLARGED) FEMALE TERMINALS

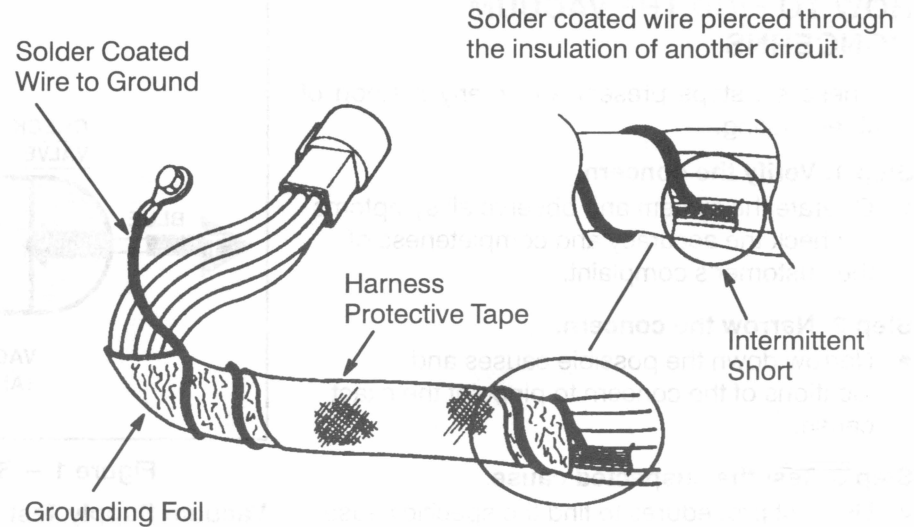

## ELECTRICAL SHORT INSIDE THE HARNESS

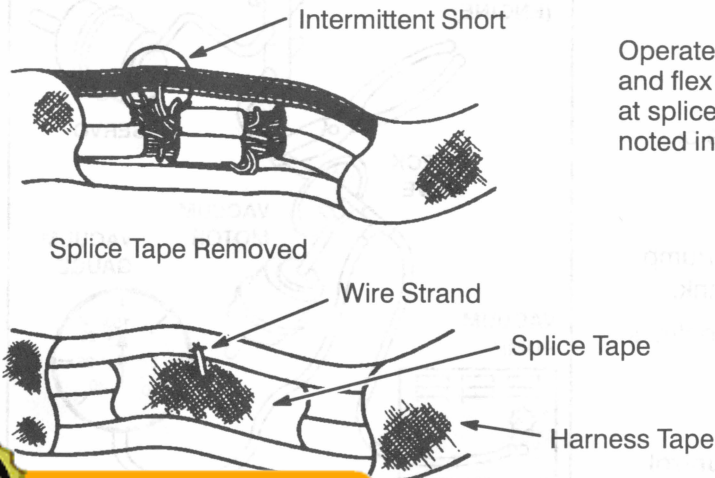

Operate the system and flex the harness at splice location noted in Section 152.

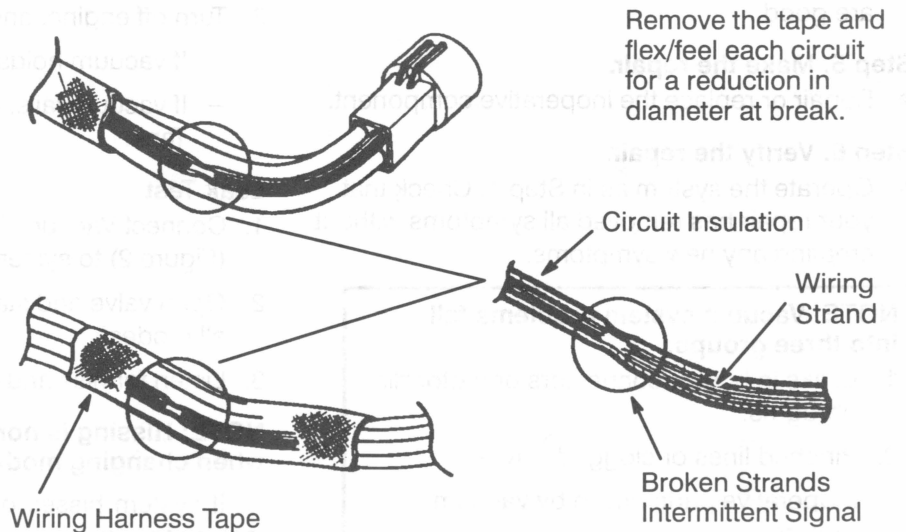

## BROKEN WIRE STRANDS IN HARNESS

**100% GUARANTEED**

**BUY IT NOW!**

**Click Here To Order**

...T WITHIN THE HARNESS

# 2-7 HOW TO USE THIS MANUAL

1996 BRONCO

## HOW TO FIND THE VACUUM CONCERNS

These six steps present an orderly method of troubleshooting.

### Step 1. Verify the concern.

- Operate the system and observe all symptoms to check the accuracy and completeness of the customer's complaint.

### Step 2. Narrow the concern.

- Narrow down the possible causes and locations of the concern to pinpoint the exact cause.

### Step 3. Test the suspected cause.

- Use test procedures to find the specific cause of the symptoms.

### Step 4. Verify the cause.

- Confirm that you have found the right cause by operating the parts of the circuit you think are good.

### Step 5. Make the repair.

- Repair or replace the inoperative component.

### Step 6. Verify the repair.

- Operate the system as in Step 1. Check that your repair has removed all symptoms without creating any new symptoms.

**NOTE: Vacuum system problems fall into three groups.**

1. Leaks in hoses, connectors or motor diaphragms.

**100% SATISFACTION GUARANTEED**

**BUY IT NOW!**

**Click Here To Order**

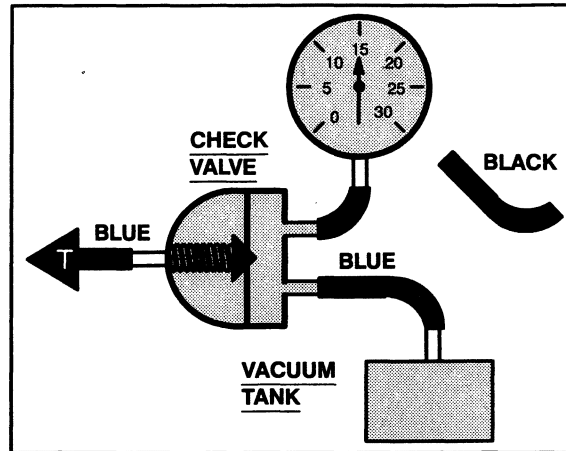

Figure 1 – System Supply Test

### Vacuum Supply Test

1. Connect Vacuum Tester to system side of Check Valve (Figure 1).
2. Start engine. Gauge should show approximately 15 inches of vacuum.
3. Turn off engine, and observe gauge:
  - If vacuum holds, supply OK.
  - If vacuum fails, replace Check Valve or Tank.

### Leak Test

1. Connect Vacuum Gauge and Vacuum Pump (Figure 2) to system hose in place of tank.
2. Open valve and start pump. Operate control in all modes.
3. Listen for hiss and observe gauge.

**NOTE: Hissing is normal at Function Control when changing modes.**

If system hisses or loses vacuum, find system leak as follows:

1. Turn on Vacuum Pump and check vacuum build-up.
2. Stop pump; vacuum should drop.
3. Clamp supply hoses with needlenose pliers, one at a time, until vacuum stops dropping (Figure 2).
4. Check vacuum schematic to find components in that line.
5. Clamp hoses through circuit to find leak.

### Component Test

1. Connect Vacuum Tester to component.
2. Pump Vacuum Tester. Check that all components operate correctly and vacuum holds.
3. Replace component if vacuum does not hold.

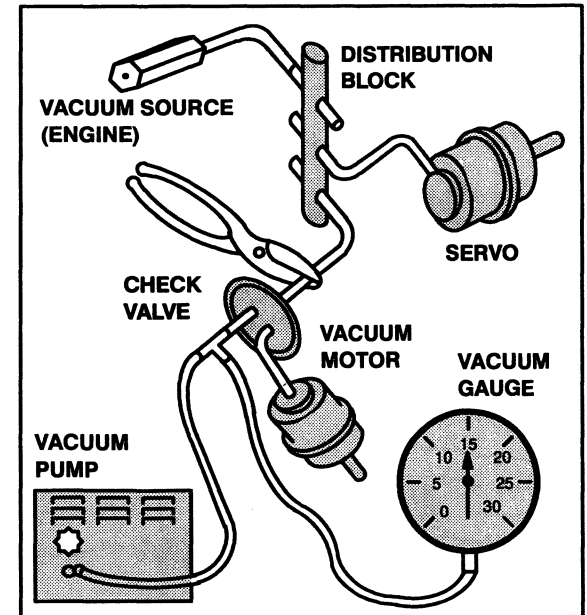
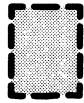
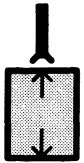

Figure 2 – Testing For Leaks In Typical Vacuum System

## ELECTRICAL SYMBOLS



**DASHED COMPONENT BOX**  
ONLY PART OF THE COMPONENT IS SHOWN ON THE PAGE; THE COMPONENT IS SHOWN COMPLETE IN ANOTHER LOCATION



**COMPONENT WITH CONNECTORS**

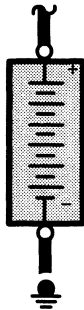

**BATTERY**

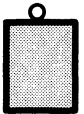

**SCREW TERMINAL ON COMPONENT**

**SOLID STATE**

**SEALED ELECTRONIC COMPONENT**  
ANY CIRCUITRY SHOWN INSIDE THE BOX IS A FUNCTIONAL

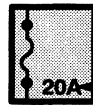

**FUSE**

CURRENT RATING

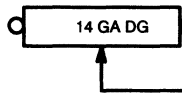

**FUSIBLE LINK**

WIRE SIZE AND COLOR

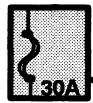

**MAXI-FUSE or FUSIBLE LINK CARTRIDGE**

CURRENT RATING

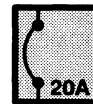

**CIRCUIT BREAKER**

CURRENT RATING

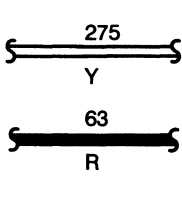

**SOLID WIRES**

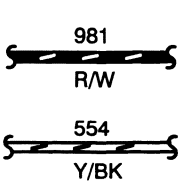

**STRIPED WIRES**

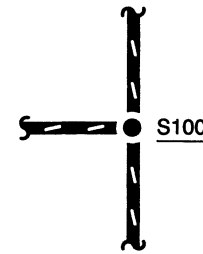

**SPLICE OR CRIMP TERMINAL**

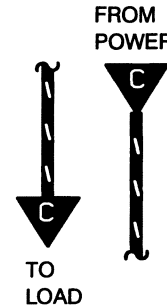

**"CUT" WIRES REFERENCED BETWEEN PAGES**  
ARROWS SHOW CURRENT FLOW FROM POWER TO GROUND



**BACKUP LIGHTS**

**"REFERENCE" WIRES**  
COMPLETE WIRING SHOWN ON ANOTHER PAGE

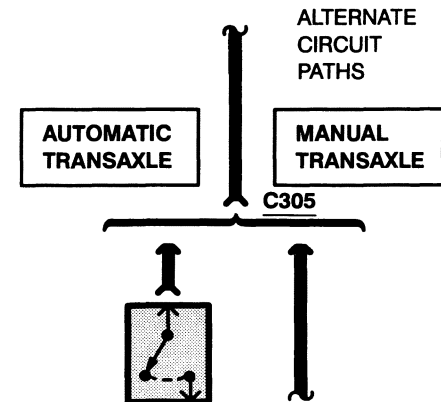

**100% SATISFACTION GUARANTEED**

**BUY IT NOW!**

**Click Here To Order**

# 2-9 HOW TO USE THIS MANUAL

1996 BRONCO

## ELECTRICAL SYMBOLS

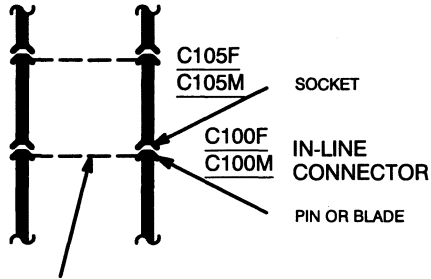

SINGLE DASHED LINE INDICATES THAT WIRE ON LEFT ALSO PASSES THROUGH THE SAME CONNECTOR

SEE GROUNDS  
PAGES 10-1,  
10-2



DASHED WIRE CIRCUITRY IS NOT SHOWN IN COMPLETE DETAIL, BUT IS COMPLETE ON ANOTHER PAGE

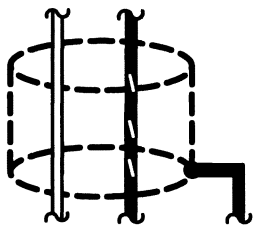

SHIELD WIRES ARE COVERED BY A SHIELD

FIELD COIL



MOTOR



HEATING ELEMENT



THERMISTOR



RHEOSTAT OR POTENTIOMETER



SOLENOID

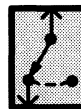

SWITCH

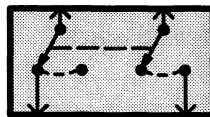

GANGED SWITCHES CONTACTS MOVE AT THE SAME TIME

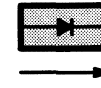

DIODES CURRENT FLOWS IN DIRECTION OF ARROW ONLY

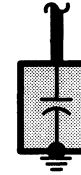

CAPACITOR



TRANSISTOR



GAUGE



LIGHT EMITTING DIODE (LED)



LIGHT BULB

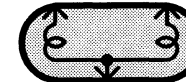

DUAL FILAMENT LIGHT BULB

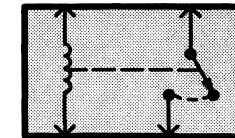

RELAY CONTACTS CHANGE POSITION WITH CURRENT THROUGH COIL

100% SATISFACTION GUARANTEED

**BUY IT NOW!**

Click Here To Order

## VACUUM SYMBOLS

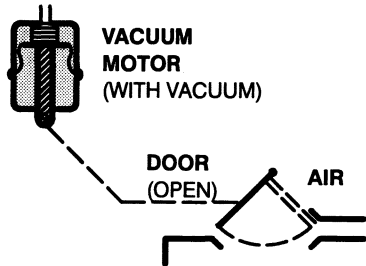
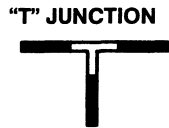

VACUUM ON VACUUM MOTOR PULLS DOOR OPEN TO LET AIR PASS THROUGH

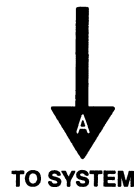

TO SYSTEM

**"CUT" HOSES REFERENCED BETWEEN PAGES**  
ARROW SHOWS FROM MANIFOLD FITTING TO COMPONENT

FROM VACUUM DISTRIBUTION

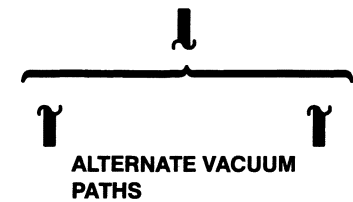

ALTERNATE VACUUM PATHS

**NOTE**  
OTHER VACUUM SYMBOLS USED ON VACUUM SYSTEM DIAGRAMS ARE FULLY EXPLAINED ON THE PAGES WHERE THEY APPEAR.

## VACUUM MOTOR OPERATION

### SINGLE DIAPHRAGM MOTOR

NO VACUUM

VACUUM

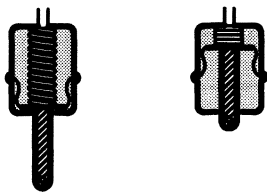

### SERVO MOTOR

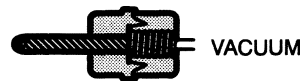

Some vacuum motors can position the actuating arm at any position between fully extended and fully retracted. The Servo is operated by a control valve that applies varying amounts of vacuum to the motor. The higher the vacuum level, the greater the retraction of the motor arm. Servo Motors work nearly the same way as two-position motors, except for the way the vacuum is applied. Servo Motors are generally larger and provide a calibrated control.

### DOUBLE DIAPHRAGM MOTOR

NO VACUUM

NO VACUUM

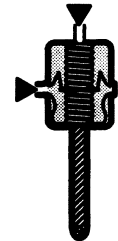

VACUUM

NO VACUUM



VACUUM

VACUUM



A double diaphragm motor has three positions (it is actually two motors in one housing). When the top port gets vacuum, the shaft pulls halfway in. When both ports get vacuum, the shaft pulls all the way in.

Vacuum motors operate like electrical solenoids, mechanically pushing or pulling a shaft. In vacuum, the shaft pulls all the way out.

**100% SATISFACTION GUARANTEED**

**BUY IT NOW!**

**Click Here To Order**

# 10-1 GROUNDS

1996 BRONCO

All circuits are  
57 BK unless  
otherwise noted.

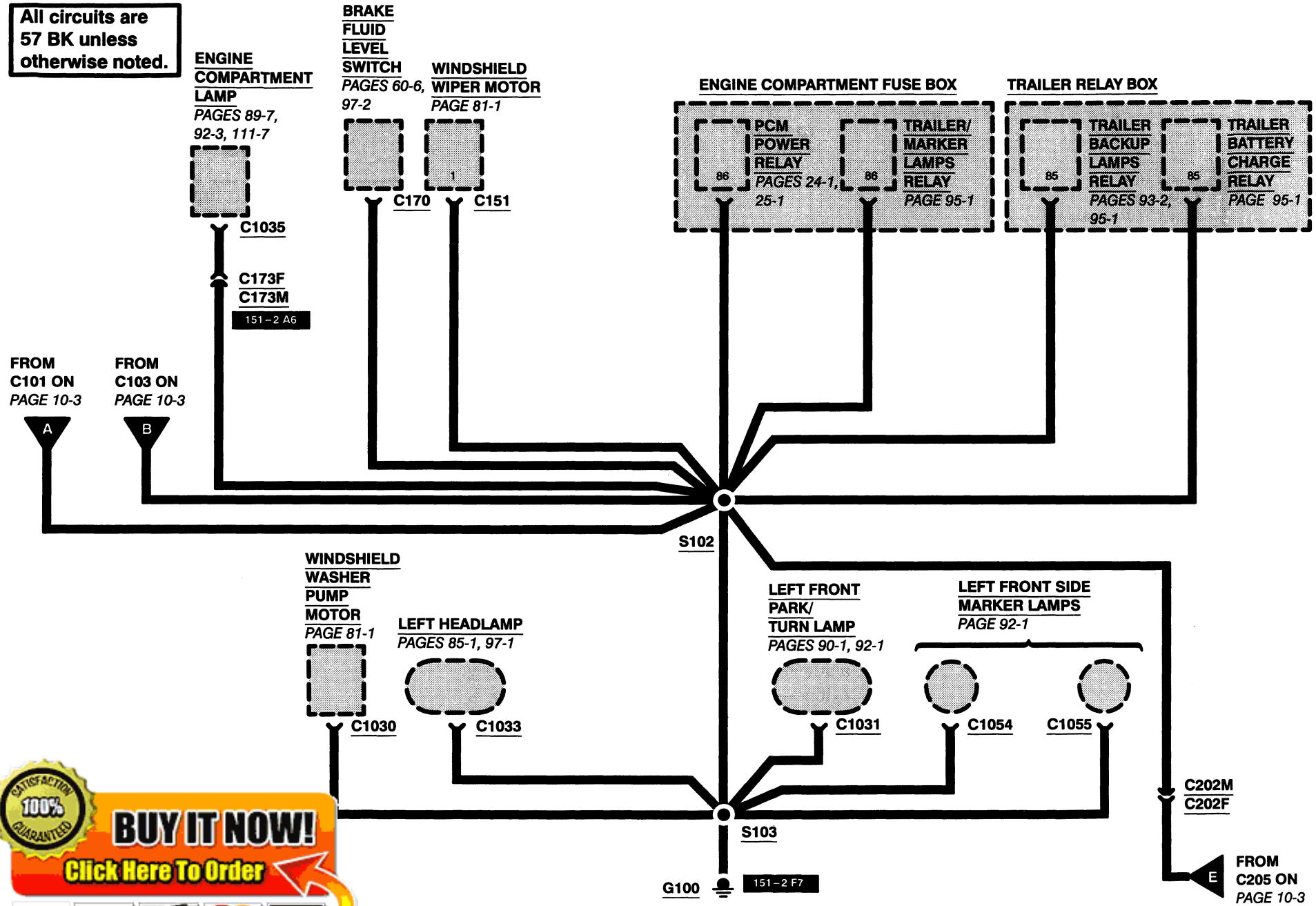

**100% SATISFACTION GUARANTEED**

**BUY IT NOW!**

**Click Here To Order**

**RIGHT HEADLAMP**  
PAGES 85-1, 97-1

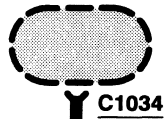

C1034

**RIGHT FRONT PARK/TURN LAMP**  
PAGES 90-1, 92-1



C1032

**RIGHT FRONT SIDE MARKER LAMPS**  
PAGE 92-1



C1053

C1052

S100

**4WABS PUMP MOTOR**  
PAGE 42-2

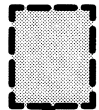

C122F  
C122M

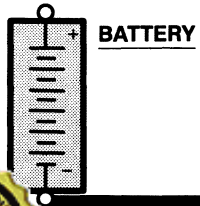

BATTERY

**DATA LINK CONNECTOR (DLC)**

5

C201F

570 BK/W

C202F  
C202M

570 BK/W

570 BK/W

S106

**POWERTRAIN CONTROL MODULE (PCM)**  
PAGES 24-1, 25-1

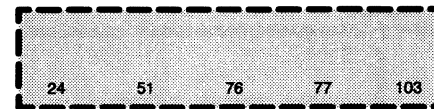

570 BK/W

570 BK/W

570 BK/W

570 BK/W

S101

**MASS AIR FLOW (MAF) SENSOR**  
PAGES 24-1, 25-1

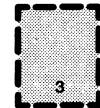

C130

570 BK/W

G101

151-2 D1

**100% SATISFACTION GUARANTEED**

**BUY IT NOW!**

**Click Here To Order**

# 10-3 GROUNDS

1996 BRONCO

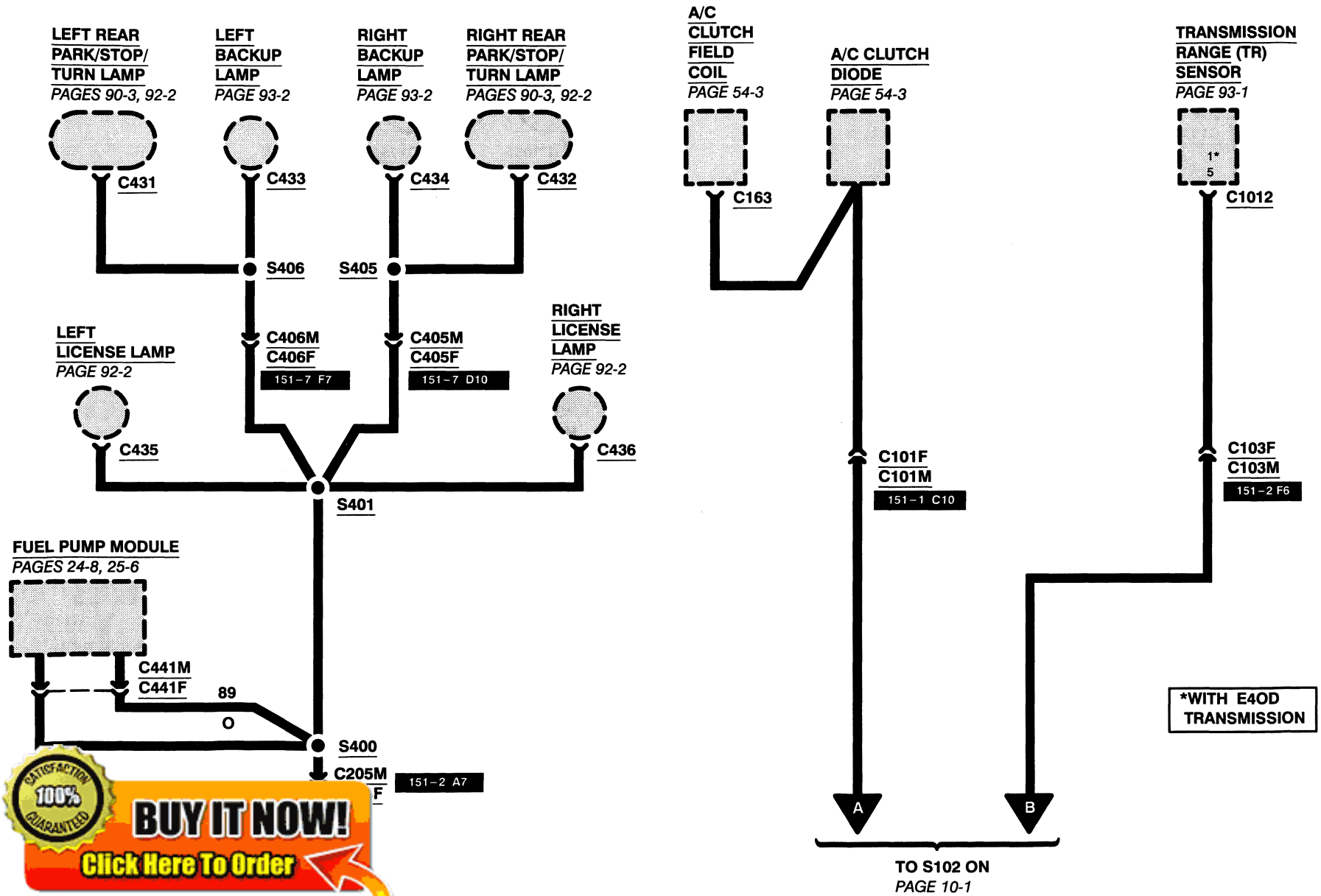

**100% SATISFACTION GUARANTEED**

**BUY IT NOW!**

**Click Here To Order**

PayPal, American Express, Discover, MasterCard, VISA



# 10-5 GROUNDS

1996 BRONCO

## INSTRUMENT CLUSTER

PAGES 60-7, 64-1

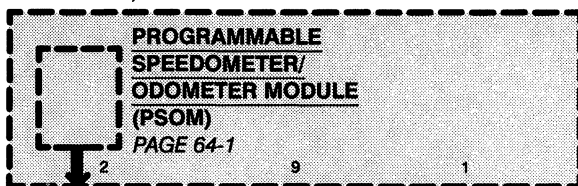

**SPEED CONTROL SERVO/AMPLIFIER ASSEMBLY**  
PAGE 31-2

**REMOTE/ KEYLESS ENTRY MODULE**  
PAGE 111-1

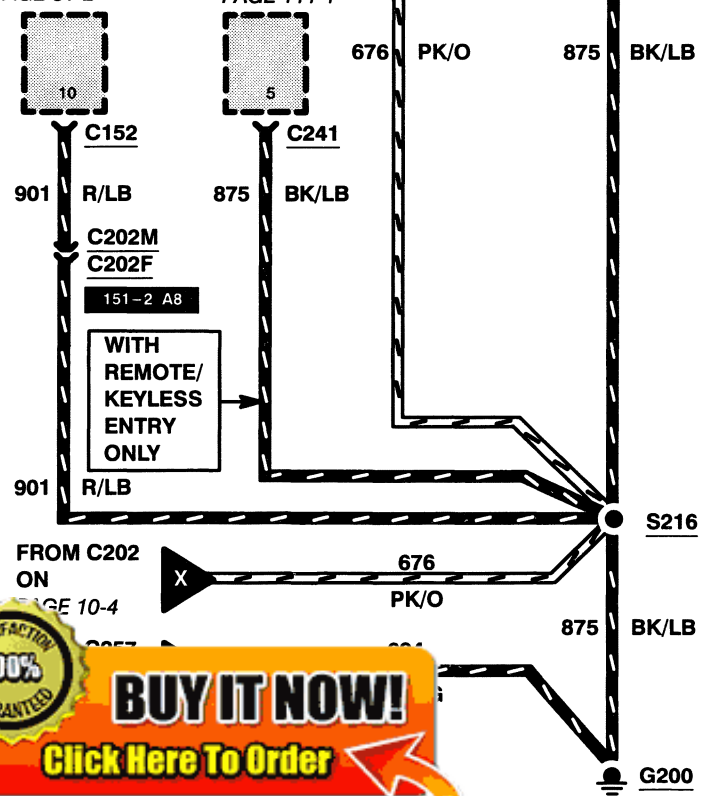

**AIR BAG DIAGNOSTIC MONITOR**  
PAGE 46-1

**ELECTRONIC SHIFT CONTROL MODULE**  
PAGE 34-1

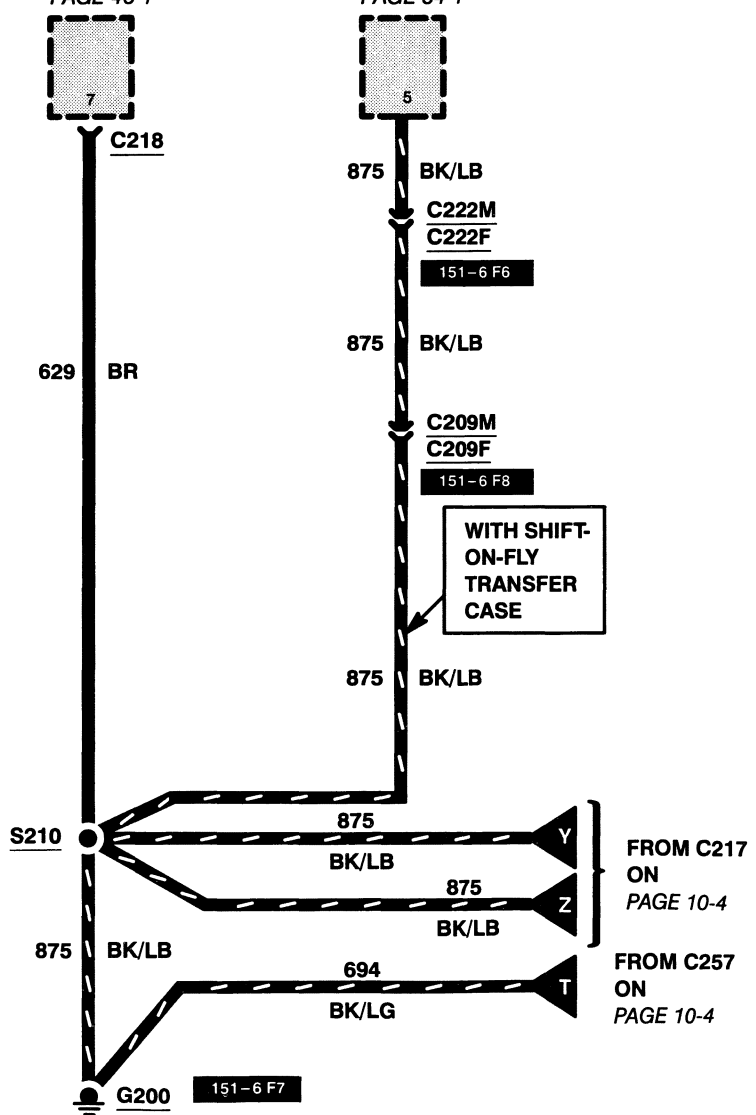

**100% SATISFACTION GUARANTEED**

**BUY IT NOW!**

**Click Here To Order**

**COMPASS/OUTSIDE  
TEMPERATURE  
MODULE**  
PAGE 102-1

**DAY/NIGHT  
MIRROR**  
PAGE 125-1



C914 C913

\* WITH  
OVER  
HEAD  
CONSOLE  
ONLY

S901

**LEFT  
POWER  
LUMBAR  
COMPRESSOR  
MOTOR**  
PAGE 122-1

**RIGHT  
POWER  
LUMBAR  
COMPRESSOR  
MOTOR**  
PAGE 122-1



\*C206F  
\*C206M

C299F  
C299M  
151-7 A1

C312  
C313M  
C313F  
151-5 C9

C317  
C314M  
C314F  
151-5 A3

**SEAT BELT  
SWITCH**  
PAGE 66-1

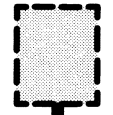

C302F  
C302M

**CAPTAIN  
CHAIRS  
ONLY**

WITH POWER LUMBAR ONLY

S200

S308

C318F C318M

C315F C315M

C908

**INSIDE  
CARGO  
LAMP**

PAGES 89-2,  
89-6, 111-6

151-7 F6

151-7 F3

G201

151-7 E1

FROM C200  
ON  
PAGE 10-9

FROM C214  
ON  
PAGE 10-7

**100% SATISFACTION GUARANTEED**

**BUY IT NOW!**

Click Here To Order

# 10-7 GROUND

1996 BRONCO

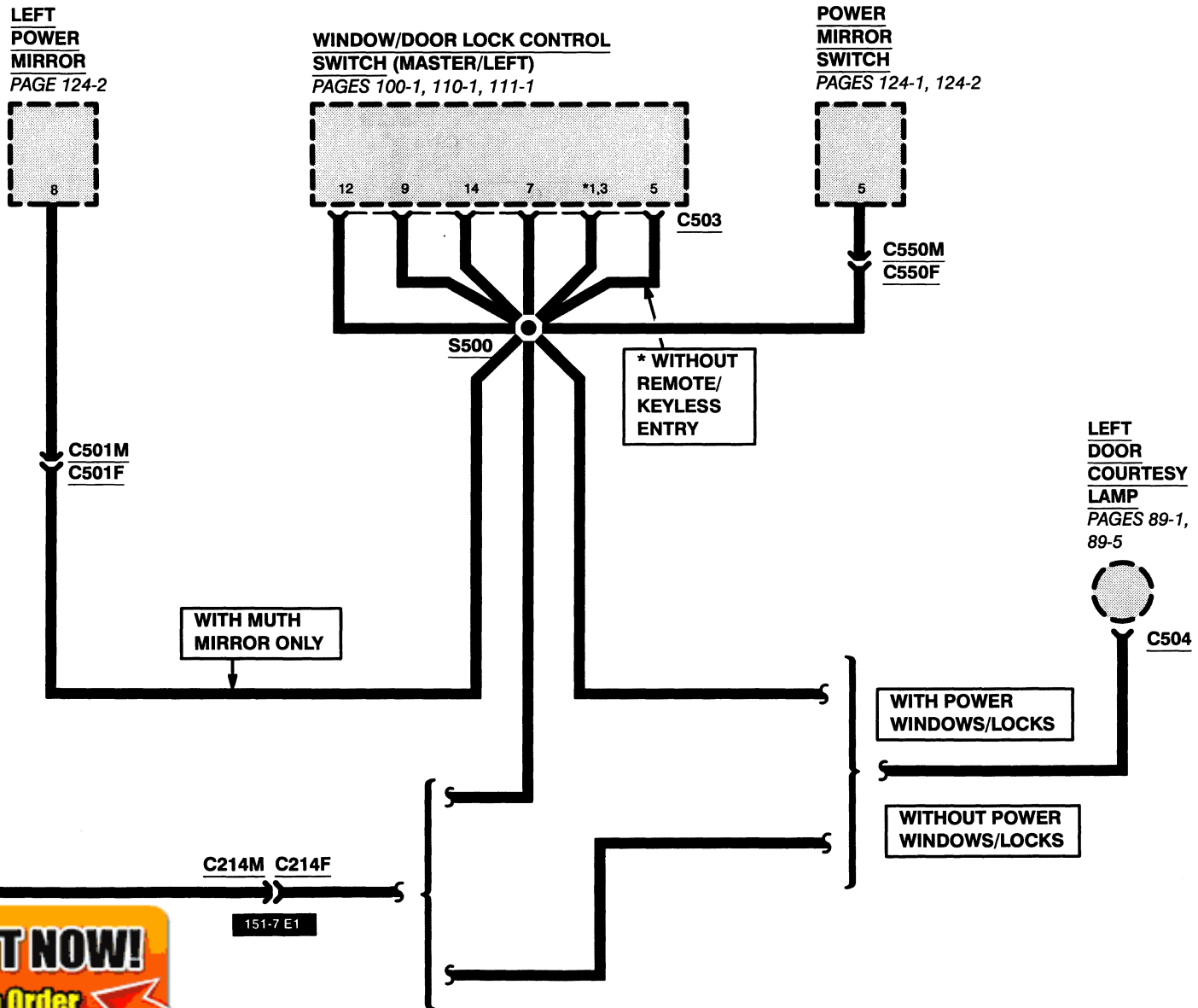

**100% SATISFACTION GUARANTEED**

**BUY IT NOW!**

**Click Here To Order**

PayPal

Discover

MasterCard

VISA

# 152-11 LOCATION INDEX

1996 BRONCO

<u>Connector</u>	<u>Location</u>	<u>Page Zone</u>	<u>Connector Page</u>	<u>Color</u>	<u>Terminal</u>
C230	Top of steering column, on multi-function switch	151-4 B10	90-4		7
C231	Top of steering column, on multi-function switch	151-4 B10	90-4	GY	10
C232	Behind lower RH side of I/P, below glove compartment	151-4 E1		BR	1
C234	Behind lower center of I/P, on auxiliary power socket	151-4 F6		BR	1
C236	In steering column, on shift lock actuator	151-4 A6			3
C240	Behind LH side of I/P, on remote keyless entry module	151-3 B10	111-8		13
C241	Behind LH side of I/P, on remote keyless entry module	151-3 B10	111-9		16
C242	Behind LH side of I/P, on remote keyless entry module	151-3 B10	111-8		13
C243	Behind LH side of I/P, on RKE program connector	*			2
C250	Behind top LH side of I/P, on instrument cluster	151-3 A6	60-9	BR	14
C251	Behind top LH side of I/P, on instrument cluster	151-3 A9	60-9	GY	14
C252	Behind top LH side of I/P, on PSOM	151-3 A7	60-8	BK	12
C257	Behind top center of I/P, on radio	151-3 A4	130-3	BK	8
C257 (Premium Sound)	Behind I/P, near radio	151-3 A4	130-3	BK	8
C258	Behind top center of I/P, on radio	151-3 A4	130-4	BK	8
C260	Behind center of I/P, on blower motor switch	151-4 A4		GY	4
C261 (Automatic)	Behind LH side of I/P, on clutch pedal position switch jumper	151-3 F4		GY	6
C261 (Manual)	Behind LH side of I/P, on clutch pedal position switch	151-3 F4	20-3	GY	6
C262	In front of RH front door jamb, on right courtesy lamp switch	151-7 F4		N	3
C263	In lower rear of LH front door jamb, on left front courtesy lamp switch	151-7 F2		GY	3
C267	Behind top LH side of I/P, on electronic shift control switch	151-4 A6	34-3	GY	8
C268	Behind RH cowl panel	151-6 A5			4
C269	Top RH side of steering column, on ignition switch	*	20-3		15
C270	Top front of RH front door	151-7 A7			3
C271	Behind RH cowl panel, on inertia fuel shutoff	151-6 A4		GY	3
	Behind top LH side of I/P, on main light switch	151-3 C9	71-2	GY	9
	Behind top LH side of I/P, on master tailgate window switch	151-4 C10	100-5	GY	5
	Top of steering column, near transmission control switch	151-4 C10			3
	Behind LH side of I/P, on park brake switch	151-3 F8		BK	1

**100% SATISFACTION GUARANTEED**

**BUY IT NOW!**

**Click Here To Order**

PayPal American Express Discover MasterCard VISA

## HOW TO IDENTIFY A BASIC HARNESSES NUMBER BY USING A "C" NUMBER

Understand these symbols before using the following listing:

**HARNESSES TO HARNESSES CONNECTION**

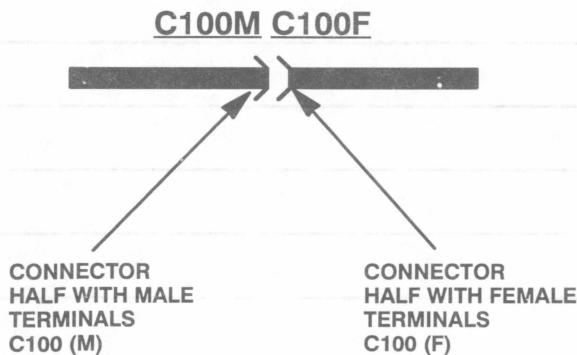

**DASHED LINES INDICATE TERMINALS OF SAME CONNECTOR**

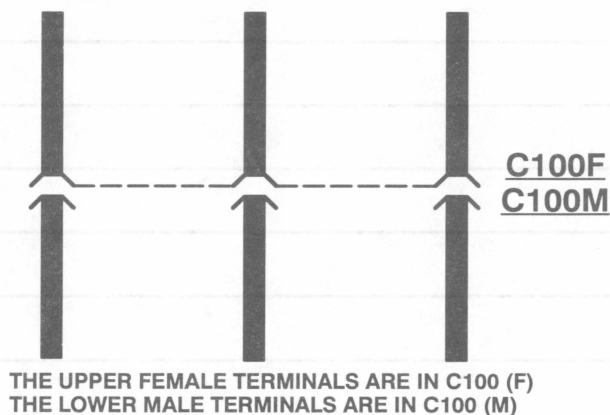

**COMPONENT CONNECTION**

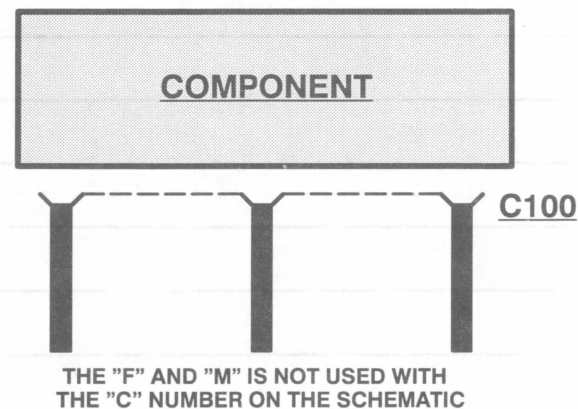

Identify the basic harness part number by:

**100% SATISFACTION GUARANTEED**

**BUY IT NOW!**

**Click Here To Order**

Find the connector "C" number in the EVTM schematics. Then locate the "C" number in the following listing and

or (such as a short or a broken wire), then choose a connector located on the same harness that has the problem. Find the connector "C" number in the EVTM schematics. Then locate the "C" number in the following listing and read the base part number of the harness that has the problem.

# HARNES CAUSAL PART NUMBER

# 153-2

1996 BRONCO

Connector Number	Wire Assembly	Connector Number	Wire Assembly	Connector Number	Wire Assembly	Connector Number	Wire Assembly
C101 (F)	9D930	C168	18A586	C213 (M)	14A509	C270 (M)	14401
C101 (M)	12A581	C169	18A586	C214 (M)	14A504	C271	14401
C102	12A581	C170	12A581	C214 (F)	14A509	C273	14401
C103 (F)	15525	C173 (F)	15A702	C217	14401	C274	14401
C103 (M)	12A581	C173 (M)	12A581	C218	14401	C275	14401
C106 (F)	12A581	C177	12A581	C219	14401	C276	14401
C106 (M)	18A586	C178	9D930	C220	14B095	C278	14401
C107 (M)	12A581	C180	9D930	C221	14B095	C279	14401
C107 (F)	12A690	C182	9D930	C222	14B095	C280	14401
C109 (F)	15525	C183	9D930	C223	14B095	C282	PIA
C109 (M)	12A581	C185	12A581	C224	14401	C283	PIA
C112 (F)	14405	C190	9D930	C226	14401	C292	14401
C112 (M)	12A581	C191	9D930	C227	PIA	C293	13A726
C115	9D930	C192	9D930	C228 (F)	14A265	C294	13A726
C116	*	C193	9D930	C228 (M)	14401	C295	13A726
C117 (F)	14K067	C194	9D930	C229 (F)	14401	C296	14401
C117 (M)	15525	C195	9D930	C229 (M)	14A504	C298	14401
C119	12A581	C196	9D930	C230	14401	C299 (F)	17K745
C120	12A581	C197	9D930	C231	14401	C299 (M)	14A504
C121	12A581	C200 (F)	14A504	C232	14401	C300 (F)	14334
C122	12A581	C200 (M)	14401	C234	13A726	C300 (M)	14A504
C123	12A581	C201	14401	C236	14401	C302	14A504
C124	12A690	C202 (F)	14401	C240	14401	C305	14B084
C126	9D930	C202 (M)	12A581	C241	14401	C306	14B084
C129	12A581	C203 (F)	18A586	C242	14401	C310	14086
C130	12A581	C203 (M)	14401	C243	14401	C311	14086
C131	12A581	C204 (F)	14401	C250	14401	C312	14B084
C135	9D930	C204 (M)	13A726	C251	14401	C313 (F)	14A504
C139 (F)	14305	C205 (F)	14401	C252	14401	C313 (M)	14B084
C139 (M)	12A581	C205 (M)	14405	C257	14401	C314 (F)	14A504
C150	9D930	C206 (F)	17K745	C258	14401	C314 (M)	14B084
C151	12A581	C206 (M)	14A504	C260	14401	C315 (F)	14335
	12A581	C207	14401	C261	14401	C315 (M)	14A504
		C209 (F)	14401	C262	14401	C317	14B084
		C209 (M)	14B095	C263	14A504	C318 (F)	13A625
		C210 (F)	14A348	C267	14401	C318 (M)	14335
		C210 (M)	14401	C268 (F)	14A265		
		C211	19B113	C268 (M)	14A509		
		C212	19B113	C269	14401		
		C213 (F)	14A265	C270 (F)	14A265		

\* NOT AVAILABLE

**100% SATISFACTION GUARANTEED**

**BUY IT NOW!**

**Click Here To Order**

PayPal, American Express, Discover, MasterCard, VISA

# 153-3

# HARNES CAUSAL PART NUMBER

1996 BRONCO

<u>Connector</u> <u>Number</u>	<u>Wire</u> <u>Assembly</u>	<u>Connector</u> <u>Number</u>	<u>Wire</u> <u>Assembly</u>	<u>Connector</u> <u>Number</u>	<u>Wire</u> <u>Assembly</u>
C326	14A504	C600	14A265	C1048	15525
C327	14A504	C601	14A265	C1049	15525
C328	14B095	C602	14A265	C1052	12A581
C329	12A581	C603	14A265	C1053	12A581
C330	12A581	C606	14A265	C1054	12A581
C402	14405	C607	14A265	C1055	12A581
C404	14405	C608	14A265	C1069	15525
C405 (F)	14405	C905	14334		
C405 (M)	13A409	C906	14334		
C406 (F)	14405	C907	13A625		
C406 (M)	13A409	C908	13A625		
C407 (F)	13A576	C911	17K745		
C407 (M)	14405	C912	17K745		
C417 (F)	PIA	C913	17K745		
C417 (M)	13A576	C914	17K745		
C418 (F)	14405	C1005	12A581		
C418 (M)	14086	C1006	12A581		
C424 (F)	13A576	C1007	9D930		
C424 (M)	14405	C1008	9D930		
C428	14086	C1012	15525		
C429	14086	C1017	9D930		
C431	13A409	C1019	12A581		
C432	13A409	C1020	15525		
C433	13A409	C1021	12A581		
C434	13A409	C1022	9D930		
C435	14405	C1023	9D930		
C436	14405	C1024	9D930		
C441	14405	C1025 (5.0L)	9D930		
C500	14A509	C1025 (5.8L)	12A690		
C501	14A509	C1028 (5.0L)	9D930		
C502	14A509	C1028 (5.8L)	15525		
C503	14A509	C1030	12A581		
C504	14A509	C1031	12A581		
C505	14A509	C1032	12A581		
C506	14A509	C1033	12A581		
C507	14A509	C1034	12A581		
C508	14A509	C1035	15A702		
C509	14A509	C1040	PIA		

**100% SATISFACTION GUARANTEED**

**BUY IT NOW!**

**Click Here To Order**

PayPal American Express Discover MasterCard VISA

# NOTES 153-4

1996 BRONCO

**100% SATISFACTION GUARANTEED**

**BUY IT NOW!**

**Click Here To Order**

PayPal American Express Cards Discover NOVUS MasterCard VISA

# 160-1 VEHICLE REPAIR LOCATION CODES

1996 BRONCO

## VEHICLE REPAIR LOCATION CODES

TO PINPOINT THE ACTUAL VEHICLE LOCATION OF A REPAIR, THE VEHICLE REPAIR LOCATION CODE IS REQUIRED.

FOR EXAMPLE, AN "X" HAS BEEN PLACED IN THE QUADRANT OF THE VEHICLE DIAGRAMS INDICATING THE LOCATION OF THE REPAIR. SEE DIAGRAMS.

LOCATION CODE, FOR THE EXAMPLE: A5/FU – (UNDER THE FLOOR OF DRIVER'S LEFT FOOT.)

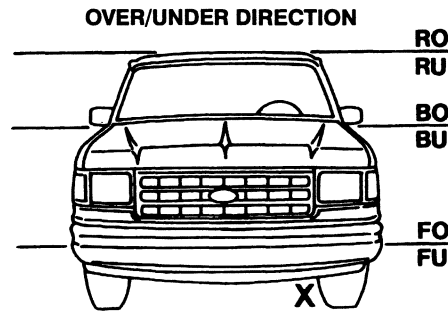
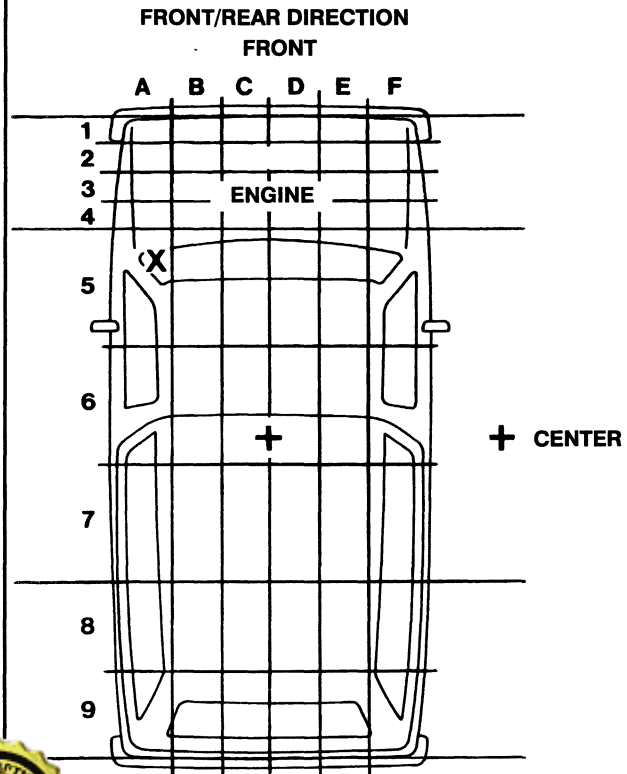

- R = ROOF LINE
- RO = ROOF OVER
- RU = ROOF UNDER
- B = BELT LINE
- BO = BELT OVER
- BU = BELT UNDER
- F = FLOOR PAN
- FO = FLOOR OVER
- FU = FLOOR UNDER

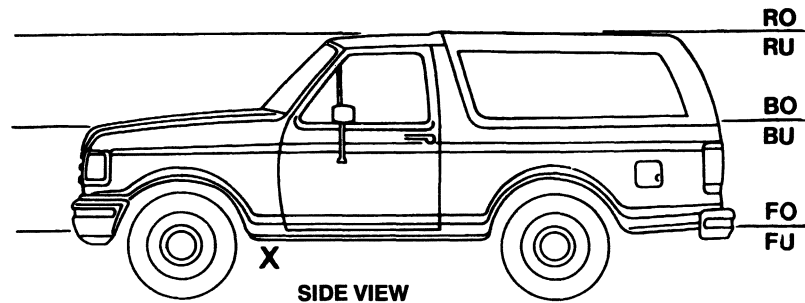

BRONCO  
FCS-12129-96

**100% SATISFACTION GUARANTEED**

**BUY IT NOW!**

**Click Here To Order**

# We Want To Hear From You!

Your suggestions will help us to improve this manual.

Mail this form or fax your comments to:

(313) 390-8727

Manual \_\_\_\_\_ Vehicle \_\_\_\_\_ Year \_\_\_\_\_

Did you find any errors in the procedures or illustrations?

YES	NO
<input type="checkbox"/>	<input type="checkbox"/>

If yes, page \_\_\_\_\_ please describe in detail: \_\_\_\_\_

---

---

---

---

Did the procedures make sense and were they easy to follow?

YES	NO
<input type="checkbox"/>	<input type="checkbox"/>

If no, page \_\_\_\_\_ please describe: \_\_\_\_\_

---

---

Is the organization of the manual clear and easy to follow?

YES	NO
<input type="checkbox"/>	<input type="checkbox"/>

Please comment: \_\_\_\_\_

---

---

Are there any important procedures not covered in this manual that you would like to see included?

YES	NO
<input type="checkbox"/>	<input type="checkbox"/>

If yes, please describe: \_\_\_\_\_

---

---

Please enclose a copy of each page marked with your suggestions.

Please tell us who you are:

Name \_\_\_\_\_

Street \_\_\_\_\_

City \_\_\_\_\_ State \_\_\_\_\_ Zip \_\_\_\_\_

Company \_\_\_\_\_



**BUY IT NOW!**

Click Here To Order



DO NOT STAPLE — USE TRANSPARENT TAPE



NO POSTAGE  
NECESSARY  
IF MAILED  
IN THE  
UNITED STATES

**BUSINESS REPLY MAIL**  
FIRST CLASS PERMIT NO. 400 DEARBORN, MICH.

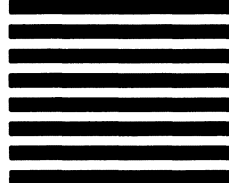

POSTAGE WILL BE PAID BY ADDRESSEE

Technical Service Publications  
EVTM  
P.O. Box 2592  
Dearborn, MI 48121-9973



**SATISFACTORY  
100%  
GUARANTEED**

**BUY IT NOW!**

**Click Here To Order**

PayPal



TECHNICAL  
PUBLICATIONS DEPARTMENT  
Ford Customer Service Division



FCS-12129-96

COPYRIGHT © 1995  
FORD MOTOR COMPANY

JUNE 1995

LITHO IN U.S.A.