

Click Here To Order

BUY IT NOW!

Buy Now

VISA AMERICAN EXPRESS DISCOVER MASTERCARD BANK



1995 BRONCO

DEMO

This DEMO contains only a few pages of the entire manual/product.

Not all Bookmarks work on the Demo, but they do on the full version.

Features:

- Searchable text
- Printable pages
- Bookmarked for easy navigation
- High Resolution images
- Zoom to see exact details
- Money back Guarantee
- Available on USB and eBook download

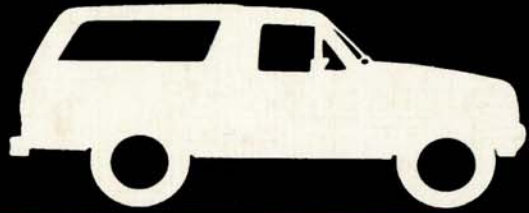

ELECTRICAL AND VACUUM TROUBLESHOOTING MANUAL



License #84356800

Copyright © 2024, Forel Publishing Company, LLC, Woodbridge, Virginia

All Rights Reserved. No part of this book may be used or reproduced in any manner whatsoever without written permission of Forel Publishing Company, LLC. For information write to Forel Publishing Company, LLC, Woodbridge, VA 22192

**1995 Bronco Electrical & Vacuum Trouble-Shooting
Manual (EVTM)
EAN: 978-1-60371-453-2
ISBN: 1-60371-453-7**

Forel Publishing Company, LLC
Woodbridge, VA 22192
Email: sales@ForelPublishing.com
<https://www.ForelPublishing.com>



This publication contains material that is reproduced and distributed under a license from Ford Motor Company. No further reproduction or distribution of the Ford Motor Company material is allowed without the express written permission of Ford Motor Company.

Note from the Publisher

This product was created from the original Ford Motor Company's publication. Every effort has been made to use the original scanned images, however, due to the condition of the material; some pages have been modified to remove imperfections.

Disclaimer

Although every effort was made to ensure the accuracy of this book, no representations or warranties of any kind are made concerning the accuracy, completeness or suitability of the information, either expressed or implied. As a result, the information contained within this book should be used as general information only. The author and Forel Publishing Company, LLC shall have neither liability nor responsibility to any person or entity with respect to any loss or damage caused, or alleged to be caused, directly or indirectly by the information contained in this book. Further, the publisher and author are not engaged in rendering legal or other professional services. If legal, mechanical, electrical, or other expert assistance is required, the professional should be sought.



ELECTRICAL AND VACUUM TROUBLESHOOTING MANUAL

FCS-12129-95

FORD CUSTOMER SERVICE DIVISION

Quality is Job 1

Ford Customer Service Division has developed a new format for the 1995 Bronco EVT. Our goal is to provide accurate and timely electrical and vacuum service information.

1995 EVT FEATURES

- **Schematic pages** now contain **COMPONENT LOCATION** references to full-view illustrations and description notes have been added to various components to describe their operation.
- **"COMPONENT TESTING"** procedures (CELL 149) that tell the user how to perform diagnostic tests on various circuits.
- **Connector End Views** are now located at the end of individual cells and are shown for connectors with five or more cavities, a circuit function chart is provided.
- Both halves of the In-line connectors (Cell 150) with 6 or more are shown and have pin numbers assigned.
- **NOTES, CAUTIONS and WARNINGS** that contain important safety information.
- Full view **"COMPONENT LOCATION VIEWS"** (CELL 151) to help locate on-vehicle components.
- Circuit voltages on schematic pages help simplify troubleshooting.
- **Cellular Pagination:** A specific section (or cell) in all EVTs is numbered by cell and starts with page 1. For example: **"HOW TO USE THIS MANUAL"** is CELL 2 and begins with page 2-1.
- **"C"** numbers are used for all electrical connectors. **"C"** numbers are listed in numerical order in the **"LOCATION INDEX"** (CELL 152).
- **Connector End Views** are now located at the end of individual cells and are shown for connectors with five or more cavities. A chart defining each circuit's function in the connector

s contain suffix to denote connector "gender" type (F-socket,

ORDERING INFORMATION

Information about how to order additional copies of this publication or other Ford publications may be obtained by writing to Helm Incorporated at the address shown below or by calling 1-800-782-4356. Other publications available include:

- Service Manuals
- Service Specification Books
- Car/Truck Wiring Diagrams
- Powertrain Control/Emissions Diagnosis Manuals

Helm Incorporated
P.O. Box 07150
Detroit, Michigan 48207



BUY IT NOW!

Click Here To Order



1-1 TABLE OF CONTENTS/INDEX

1995 BRONCO

Table Of Contents

How to Use This Manual	2-1
Grounds	10-1
Fuse Panel/Circuit Protection	11-1
Charging System	12-1
Power Distribution	13-1
Starting System	20-1
Ignition System	21-1
Engine Controls (5.0L)	24-1
Engine Controls (5.8L)	25-1
4R70W Transmission	29-1
E4OD Transmission	30-1
Speed Control	31-1
All-Wheel Drive	34-1
Shift Lock	37-1
Anti-Lock Brakes	42-1
Horn/Cigar Lighter	44-1
Air Bags	46-1
Heater	53-1
Air Conditioner/Heater	54-1
Rear Window Defroster	56-1
Instrument Cluster	60-1
Vehicle Speed Sensor	64-1
Warning Chime	66-1
Instrument Illumination	71-1
Interval Wiper/Washer	81-1
Headlamps	85-1
Courtesy Lamps	89-1
Turn/Stop/Hazard Lamps	90-1
Exterior Lamps	92-1
Backup Lamps	93-1
Trailer/Camper Adapter	95-1
Daytime Running Lamps	97-1
Power Windows	100-1
Compass/Outside Temperature	102-1
Power Door Locks	110-1
Power Windows	111-1
Power Windows	112-1
Power Windows	113-1
Power Windows	114-1
Power Windows	115-1
Power Windows	116-1
Power Windows	117-1
Power Windows	118-1
Power Windows	119-1
Power Windows	120-1
Power Windows	121-1
Power Windows	122-1
Power Windows	123-1
Power Windows	124-1
Power Windows	125-1
Power Windows	126-1
Power Windows	127-1
Power Windows	128-1
Power Windows	129-1
Power Windows	130-1
Power Windows	131-1
Power Windows	132-1
Power Windows	133-1
Power Windows	134-1
Power Windows	135-1
Power Windows	136-1
Power Windows	137-1
Power Windows	138-1
Power Windows	139-1
Power Windows	140-1
Power Windows	141-1
Power Windows	142-1
Power Windows	143-1
Power Windows	144-1
Power Windows	145-1
Power Windows	146-1
Power Windows	147-1
Power Windows	148-1
Power Windows	149-1
Power Windows	150-1
Power Windows	151-1
Power Windows	152-1
Power Windows	153-1
Power Windows	154-1
Power Windows	155-1
Power Windows	156-1
Power Windows	157-1
Power Windows	158-1
Power Windows	159-1
Power Windows	160-1
Power Windows	161-1
Power Windows	162-1
Power Windows	163-1
Power Windows	164-1
Power Windows	165-1
Power Windows	166-1
Power Windows	167-1
Power Windows	168-1
Power Windows	169-1
Power Windows	170-1
Power Windows	171-1
Power Windows	172-1
Power Windows	173-1
Power Windows	174-1
Power Windows	175-1
Power Windows	176-1
Power Windows	177-1
Power Windows	178-1
Power Windows	179-1
Power Windows	180-1
Power Windows	181-1
Power Windows	182-1
Power Windows	183-1
Power Windows	184-1
Power Windows	185-1
Power Windows	186-1
Power Windows	187-1
Power Windows	188-1
Power Windows	189-1
Power Windows	190-1
Power Windows	191-1
Power Windows	192-1
Power Windows	193-1
Power Windows	194-1
Power Windows	195-1
Power Windows	196-1
Power Windows	197-1
Power Windows	198-1
Power Windows	199-1
Power Windows	200-1
Power Windows	201-1
Power Windows	202-1
Power Windows	203-1
Power Windows	204-1
Power Windows	205-1
Power Windows	206-1
Power Windows	207-1
Power Windows	208-1
Power Windows	209-1
Power Windows	210-1
Power Windows	211-1
Power Windows	212-1
Power Windows	213-1
Power Windows	214-1
Power Windows	215-1
Power Windows	216-1
Power Windows	217-1
Power Windows	218-1
Power Windows	219-1
Power Windows	220-1
Power Windows	221-1
Power Windows	222-1
Power Windows	223-1
Power Windows	224-1
Power Windows	225-1
Power Windows	226-1
Power Windows	227-1
Power Windows	228-1
Power Windows	229-1
Power Windows	230-1
Power Windows	231-1
Power Windows	232-1
Power Windows	233-1
Power Windows	234-1
Power Windows	235-1
Power Windows	236-1
Power Windows	237-1
Power Windows	238-1
Power Windows	239-1
Power Windows	240-1
Power Windows	241-1
Power Windows	242-1
Power Windows	243-1
Power Windows	244-1
Power Windows	245-1
Power Windows	246-1
Power Windows	247-1
Power Windows	248-1
Power Windows	249-1
Power Windows	250-1
Power Windows	251-1
Power Windows	252-1
Power Windows	253-1
Power Windows	254-1
Power Windows	255-1
Power Windows	256-1
Power Windows	257-1
Power Windows	258-1
Power Windows	259-1
Power Windows	260-1
Power Windows	261-1
Power Windows	262-1
Power Windows	263-1
Power Windows	264-1
Power Windows	265-1
Power Windows	266-1
Power Windows	267-1
Power Windows	268-1
Power Windows	269-1
Power Windows	270-1
Power Windows	271-1
Power Windows	272-1
Power Windows	273-1
Power Windows	274-1
Power Windows	275-1
Power Windows	276-1
Power Windows	277-1
Power Windows	278-1
Power Windows	279-1
Power Windows	280-1
Power Windows	281-1
Power Windows	282-1
Power Windows	283-1
Power Windows	284-1
Power Windows	285-1
Power Windows	286-1
Power Windows	287-1
Power Windows	288-1
Power Windows	289-1
Power Windows	290-1
Power Windows	291-1
Power Windows	292-1
Power Windows	293-1
Power Windows	294-1
Power Windows	295-1
Power Windows	296-1
Power Windows	297-1
Power Windows	298-1
Power Windows	299-1
Power Windows	300-1
Power Windows	301-1
Power Windows	302-1
Power Windows	303-1
Power Windows	304-1
Power Windows	305-1
Power Windows	306-1
Power Windows	307-1
Power Windows	308-1
Power Windows	309-1
Power Windows	310-1
Power Windows	311-1
Power Windows	312-1
Power Windows	313-1
Power Windows	314-1
Power Windows	315-1
Power Windows	316-1
Power Windows	317-1
Power Windows	318-1
Power Windows	319-1
Power Windows	320-1
Power Windows	321-1
Power Windows	322-1
Power Windows	323-1
Power Windows	324-1
Power Windows	325-1
Power Windows	326-1
Power Windows	327-1
Power Windows	328-1
Power Windows	329-1
Power Windows	330-1
Power Windows	331-1
Power Windows	332-1
Power Windows	333-1
Power Windows	334-1
Power Windows	335-1
Power Windows	336-1
Power Windows	337-1
Power Windows	338-1
Power Windows	339-1
Power Windows	340-1
Power Windows	341-1
Power Windows	342-1
Power Windows	343-1
Power Windows	344-1
Power Windows	345-1
Power Windows	346-1
Power Windows	347-1
Power Windows	348-1
Power Windows	349-1
Power Windows	350-1
Power Windows	351-1
Power Windows	352-1
Power Windows	353-1
Power Windows	354-1
Power Windows	355-1
Power Windows	356-1
Power Windows	357-1
Power Windows	358-1
Power Windows	359-1
Power Windows	360-1
Power Windows	361-1
Power Windows	362-1
Power Windows	363-1
Power Windows	364-1
Power Windows	365-1
Power Windows	366-1
Power Windows	367-1
Power Windows	368-1
Power Windows	369-1
Power Windows	370-1
Power Windows	371-1
Power Windows	372-1
Power Windows	373-1
Power Windows	374-1
Power Windows	375-1
Power Windows	376-1
Power Windows	377-1
Power Windows	378-1
Power Windows	379-1
Power Windows	380-1
Power Windows	381-1
Power Windows	382-1
Power Windows	383-1
Power Windows	384-1
Power Windows	385-1
Power Windows	386-1
Power Windows	387-1
Power Windows	388-1
Power Windows	389-1
Power Windows	390-1
Power Windows	391-1
Power Windows	392-1
Power Windows	393-1
Power Windows	394-1
Power Windows	395-1
Power Windows	396-1
Power Windows	397-1
Power Windows	398-1
Power Windows	399-1
Power Windows	400-1
Power Windows	401-1
Power Windows	402-1
Power Windows	403-1
Power Windows	404-1
Power Windows	405-1
Power Windows	406-1
Power Windows	407-1
Power Windows	408-1
Power Windows	409-1
Power Windows	410-1
Power Windows	411-1
Power Windows	412-1
Power Windows	413-1
Power Windows	414-1
Power Windows	415-1
Power Windows	416-1
Power Windows	417-1
Power Windows	418-1
Power Windows	419-1
Power Windows	420-1
Power Windows	421-1
Power Windows	422-1
Power Windows	423-1
Power Windows	424-1
Power Windows	425-1
Power Windows	426-1
Power Windows	427-1
Power Windows	428-1
Power Windows	429-1
Power Windows	430-1
Power Windows	431-1
Power Windows	432-1
Power Windows	433-1
Power Windows	434-1
Power Windows	435-1
Power Windows	436-1
Power Windows	437-1
Power Windows	438-1
Power Windows	439-1
Power Windows	440-1
Power Windows	441-1
Power Windows	442-1
Power Windows	443-1
Power Windows	444-1
Power Windows	445-1
Power Windows	446-1
Power Windows	447-1
Power Windows	448-1
Power Windows	449-1
Power Windows	450-1
Power Windows	451-1
Power Windows	452-1
Power Windows	453-1
Power Windows	454-1
Power Windows	455-1
Power Windows	456-1
Power Windows	457-1
Power Windows	458-1
Power Windows	459-1
Power Windows	460-1
Power Windows	461-1
Power Windows	462-1
Power Windows	463-1
Power Windows	464-1
Power Windows	465-1
Power Windows	466-1
Power Windows	467-1
Power Windows	468-1
Power Windows	469-1
Power Windows	470-1
Power Windows	471-1
Power Windows	472-1
Power Windows	473-1
Power Windows	474-1
Power Windows	475-1
Power Windows	476-1
Power Windows	477-1
Power Windows	478-1
Power Windows	479-1
Power Windows	480-1
Power Windows	481-1
Power Windows	482-1
Power Windows	483-1
Power Windows	484-1
Power Windows	485-1
Power Windows	486-1
Power Windows	487-1
Power Windows	488-1
Power Windows	489-1
Power Windows	490-1
Power Windows	491-1
Power Windows	492-1
Power Windows	493-1
Power Windows	494-1
Power Windows	495-1
Power Windows	496-1
Power Windows	497-1
Power Windows	498-1
Power Windows	499-1
Power Windows	500-1

Component Testing	149-1
In-Line Connector Faces	150-1
Component Location Views	151-1
Location Index	152-1
Harness Causal Part Number	153-1
Vehicle Repair Location Codes	160-1

Index

4R70W Transmission	29-1
Air Bags	46-1
All-Wheel Drive:	
Electronic	34-1
Air Conditioner/Heater:	
Vacuum	54-1
Electrical	54-2
Anti-Lock Brakes	42-1
Anti-Theft	112-1
Automatic Day/Night Mirrors	125-1
Charging System	12-1
Cigar Lighter	44-1
Fuse Panel/Circuit Protection	11-1
Component Testing:	
A/C Function Selector Switch	149-7
Blower Switch	149-8
Heater Function Selector Switch	149-6
Ignition Switch	149-2
Introduction	149-1
Main Light Switch	149-1
Transmission Range (TR) Sensor	149-9
Multi-function Switch	149-3 to 149-5
Engine Controls	13-1
5.0L	24-1
5.8L	25-1
Courtesy Lamps	89-1
Daytime Running Lamps	97-1
E4OD Transmission	30-1
Engine Compartment Fuse Panel	13-1
5.0L	24-1
5.8L	25-1
Fuse Panel:	
Fuse 1	13-10
Fuse 2	13-14

Fuse 4	13-13
Fuse 6	13-14
Fuse 7	13-10
Fuse 8	13-12
Fuse 9	13-7
Fuse 10	13-15
Fuse 11	13-14
C.B. 12	13-8
Fuse 13	13-7
C.B. 14	13-14
Fuse 16	13-8
Fuse 17	13-11
Fuse 18	13-10
Gauges:	
Coolant Temperature	60-2
Engine Oil Pressure	60-2
Fuel	60-1
Tachometer	60-5
Voltmeter	60-1
Grounds:	
G100	10-1
G101	10-2
G102	10-11
G103	10-3
G104	10-2
G200	10-4, 10-10
G201	10-11
G400	56-1
Headlamps	85-1
Heater	53-1
Horn	44-1
Ignition Switch	13-3
Ignition System	21-1
Indicators:	
4 x 4	60-3
Air Bags	60-3
Anti-lock Brake	42-1, 60-3
Anti-Theft	60-3, 112-1
Charge	12-1, 60-4

100% SATISFACTION GUARANTEED

BUY IT NOW!

Click Here To Order

PayPal Discover MasterCard VISA

TABLE OF CONTENTS/INDEX 1-2

1995 BRONCO

Fasten Seat Belt	60-4, 66-1
Hi Beam	60-4, 85-1
Low Range	60-3
Malfunction:	
5.0L	24-7, 60-3
5.8L	25-5, 25-11, 60-3
Turn	60-4, 90-1
Instrument Cluster	60-1
Instrument Illumination	71-1
Interval Wiper/Washer	81-1
Lamps (Exterior):	
Backup	93-2
Engine Compartment	89-7, 111-7, 92-3
Hazard	90-1
License	92-2
Marker	92-1
Park	92-2
Stop	90-2
Turn:	
Front	90-1
Rear	90-1, 90-2
Lamps (Interior):	
Dome/Map/Cargo	89-2, 89-5
Courtesy Lamps	89-1
Main Light Switch	13-15
Power Distribution	13-1
Door Locks	110-1
Lumbar Seats:	
Captain's Chairs	122-1
Mirrors	124-1
Overhead Console	102-1
Programmable Speedometer/ Odometer Module	60-7, 64-1
Radio	130-1
Rear Window Defroster	56-1
Steering Wheel Lock/Keyless Entry	111-1
Tire Pressure Monitoring System	37-1
Traction Control System	31-1, 31-2
Tire Pressure Monitoring System	20-1
Tire Pressure Monitoring System	95-1
Tire Pressure Monitoring System	140-1

Vehicle Speed Sensor	64-1
Warning Chime	66-1
Windows:	
Cab	100-1
Tailgate	100-2
Wiper/Washer (Interval)	81-1

IMPORTANT SAFETY NOTICE

Appropriate service methods and proper repair procedures are essential for the safe, reliable operation of all motor vehicles, as well as the personal safety of the individual doing the work. This Manual provides general directions for accomplishing service and repair work with tested, effective techniques. Following them will help assure reliability.

There are numerous variations in procedures, techniques, tools, and parts for servicing vehicles, as well as in the skill of the individual doing the work. This Manual cannot possibly anticipate all such variations and provide advice or cautions as to each. Accordingly, anyone who departs from the instructions provided in this Manual must first establish that he compromises neither his personal safety nor the vehicle integrity by his choice of methods, tools or parts.



2-1 HOW TO USE THIS MANUAL

1995 BRONCO

The purpose of this manual is to show electrical and vacuum circuits in a clear and simple fashion to make troubleshooting easier. **NOTES**, **CAUTIONS** and **WARNINGS** contain important information.

- **NOTES** describe how switches and other components operate to help complete a particular procedure.
- **CAUTIONS** provide information that could prevent making an error that may damage the vehicle.
- **WARNINGS** provide information to prevent personal injury.

The **WARNINGS** list on page 2-2 contains general warnings to follow when servicing a vehicle.

Components that work together are shown together. All electrical components used in a specific system are shown on one diagram. The circuit breaker or fuse is shown at the top of the page. All wires, connectors, components and splices are shown in the flow of current to ground at the bottom of the page. If a component is used in several different systems, it is shown in several places. For example, the Main Light Switch is electrically a part of many systems and is repeated on many pages.

In some cases, a component may seem (by its name) to belong to a system where it has no electrical connection. For example, Radio Illumination is electrically part of Instrument Illumination, but because it has no electrical connection to the Radio system, it is not shown on

text blocks located next to each component and connector and refer the user to the appropriate illustration page and zone. The description notes describe the operation of the component.

Schematic pages contain circuit voltages to help simplify troubleshooting hints. 12V is used to imply battery voltage on a component connector terminal, and 0V is used to show that there should be continuity to ground on that particular terminal. Conditional voltages such as "12V with the ignition switch in RUN" will also be provided. Troubleshooting hints that can't be simplified with circuit voltages will be shown at the end of each cell.

Component connector face information specific to a certain cell is found at the end of that cell. A Connector Face Reference List is provided to locate connector faces that are shown in different cells. Component connectors with five or more terminals are illustrated and are accompanied by a pinout chart that lists the function of all circuitry associated with that component.

"GROUNDS" (Cell 10) contains ground circuitry shown in complete detail. This information is useful for checking interconnections of the ground circuits of different systems.

"POWER DISTRIBUTION" (Cell 13) contains power distribution circuitry shown in complete detail. This section displays how the various fuses are powered and, in turn, how each system is powered.

"COMPONENT TESTING" (Cell 149) contains testing procedures for various switches. This information includes schematics, component terminal locations and step-by-step procedures.

"IN-LINE CONNECTOR FACES" (Cell 150) contains illustrations of all the in-line connectors that have 6 or more terminals. The terminals have pin numbers assigned to them.

"COMPONENT LOCATION VIEWS" (Cell 151) contains full-view illustrations which show the location of all components and connectors in the vehicle.

The **"LOCATION INDEX"** (Cell 152) provides the base part numbers, locations, connector face references and illustration references for all components, connectors, splices and grounds.

HELPFUL REMINDERS

Before using the EVTM for troubleshooting, refer to these HELPFUL REMINDERS:

1. The abbreviation T/O, for take out, used in the Location Index (Cell 152), refers to the point at which a group of wires branch off the harness trunk. Refer to the wiring harness illustration.

to full-
vari-
erse-

Wiring harness at back of Instrument Panel, showing typical T/O (Take Out) locations

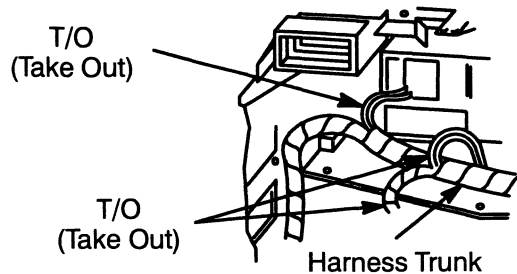

2. If a connector serves the same purpose in two separate versions (e.g., Automatic/Manual), but is physically different, *two* connector numbers are used. However, if a connector serves the same purpose in two separate versions (e.g., Automatic/Manual) and is physically the same, but the wire colors are different, only *one* connector number is used. If the same physical connector is used more than once, then more than *one* connector number is used.
3. Wiring schematics provide a picture of how and under what conditions the circuit is powered, of the current path to circuit components, and of how a circuit is grounded. Each circuit component is named (underlined titles). Wire and connector colors are listed as follows (standard Ford color abbreviations are used):

COLOR ABBREVIATIONS

BL	Blue	N	Natural
BK	Black	O	Orange
BR	Brown	PK	Pink
DB	Dark Blue	P	Purple
DG	Dark Green	R	Red
GN	Green	T	Tan
GY	Gray	W	White
LB	Light Blue	Y	Yellow
LG	Light Green		

Note: Whenever a wire is labeled with two colors, the first color listed is the basic color of the wire, and the second color listed is the stripe marking of the wire.

4. When reporting Vehicle Repair Location Codes to Ford Customer Service Division, refer to Cell 160 (beginning on page 160-1). Note: Do *not* use the illustrations in Cell 151 (beginning on page 151-1) for reporting Vehicle Repair Location Codes.

5. WARNINGS

- *Always wear safety glasses for eye protection.*
- *Use safety stands whenever a procedure requires being under a vehicle.*
- *Be sure that the Ignition Switch is always in the OFF position, unless otherwise required by the procedure.*
- *Set the parking brake when working on any vehicle. An automatic transmission should be in PARK. A manual transmission should be in NEUTRAL.*
- *Operate the engine only in a well-ventilated area to avoid danger of carbon monoxide.*

- *Keep away from moving parts, especially the fan and belts, when the engine is running.*
- *To prevent serious burns, avoid contact with hot metal parts such as the radiator, exhaust manifold, tail pipe, catalytic converter and muffler.*
- *Do not allow flame or sparks near the battery. Gases are always present in and around the battery cell. An explosion could occur.*
- *Do not smoke when working on a vehicle.*
- *To avoid injury, always remove rings, watches, loose hanging jewelry and avoid wearing loose clothing.*

HOW TO FIND ELECTRICAL CONCERNS

TROUBLESHOOTING STEPS

These six steps present an orderly method of troubleshooting.

Step 1. Verify the concern.

- Operate the complete system to check the accuracy and completeness of the customer's complaint.

Step 2. Narrow the concern.

- Using the EVTMM, narrow down the possible causes and locations of the concern to pinpoint the exact cause.
- Read the description notes at the components and study the wiring schematic. You should then know enough about the circuit operation to determine where to check for the trouble. Further information can be found by referring to the Service Manual pages listed in the box at the top of the page.

100% SATISFACTION GUARANTEED

BUY IT NOW!

Click Here To Order

2-3 HOW TO USE THIS MANUAL

1995 BRONCO

Step 3. Test the suspected cause.

- Use electrical test procedures to find the specific cause of the symptoms.
- The component location reference bars and the pictures will help you find components. The Location Index (at the end of the manual) gives component location information for connectors, diodes, resistors, splices and grounds.

Step 4. Verify the cause.

- Confirm that you have found the correct cause by connecting jumper wires and/or temporarily installing a known good component and operating the circuit.

Step 5. Make the repair.

- Repair or replace the inoperative component.

Step 6. Verify the repair.

- Operate the system as in Step 1 and check that your repair has removed all symptoms without creating any new symptoms.

Some engine circuits may need special test equipment and special procedures. See the *Service Manual* and other service books for details. You will find the circuits in this manual to be helpful with those special test procedures.

TROUBLESHOOTING TOOLS

JUMPER WIRE

This is a test lead used to connect two points of a circuit. A Jumper Wire can bypass an open to complete a circuit.

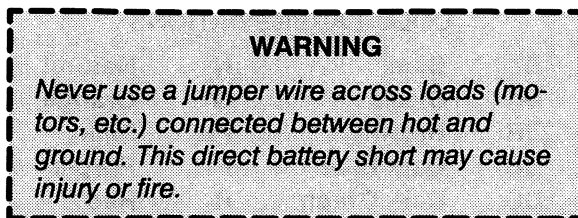

VOLTMETER

A DC Voltmeter measures circuit voltage. Connect negative (- or black) lead to ground, and positive (+ or red) lead to voltage measuring point.

OHMMETER

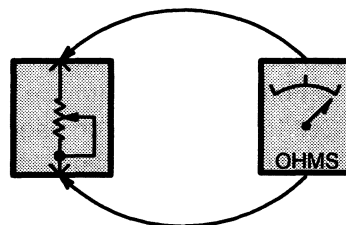

Figure 1—Resistance Check

An Ohmmeter shows the resistance between two connected points (Figure 1).

TEST LAMP

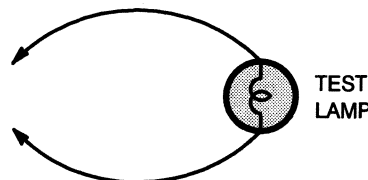

Figure 2—Test Lamp

A Test Light is a 12-volt bulb with two test leads (Figure 2).

Uses: Voltage Check, Short Check.

SELF-POWERED TEST LAMP

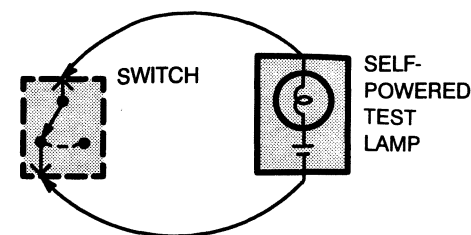

Figure 3—Continuity Check

The Self-Powered Test Lamp is a bulb, battery and set of test leads wired in series (Figure 3). When connected to two points of a continuous circuit, the bulb glows.

Uses: Continuity Check, Ground Check.

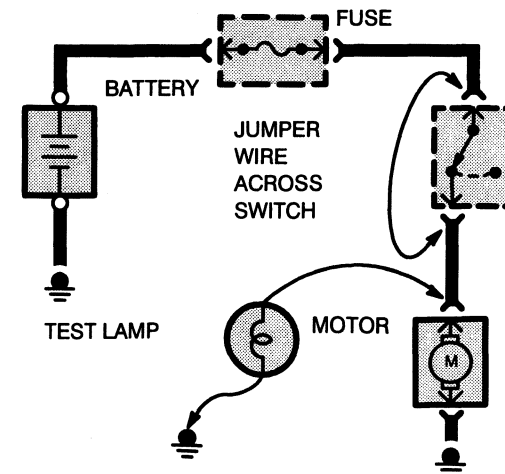
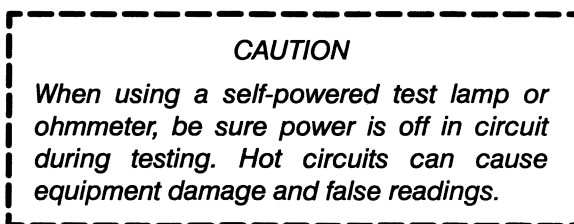

Figure 4—Switch Circuit Check and Voltage Check

100% SATISFACTION GUARANTEED

BUY IT NOW!

Click Here To Order

PayPal American Express Discover MasterCard VISA

In an inoperative circuit with a switch in series with the load, jumper the terminals of the switch to power the load. If jumpering the terminals powers the circuit, the switch is inoperative (Figure 4).

CONTINUITY CHECK (Locating open circuits)

Connect one lead of Self-Powered Test Lamp or Ohmmeter to each end of circuit (Figure 3). Lamp will glow if circuit is closed. Switches and fuses can be checked in the same way.

VOLTAGE CHECK

Connect one lead of test lamp to a known good ground or the negative (-) battery terminal. Test for voltage by touching the other lead to the test point. Bulb goes on when the test point has voltage (Figure 4).

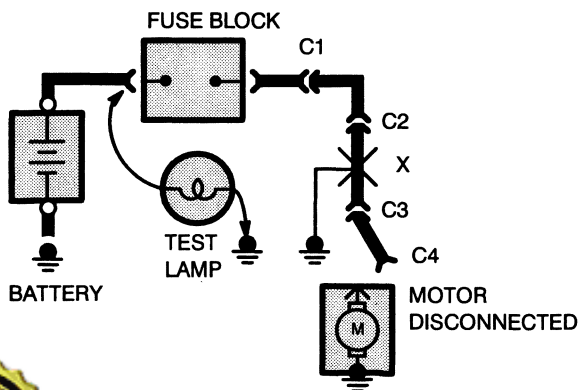

A fuse that repeatedly blows is usually caused by a short to ground. It's important to be able to locate such a short quickly (Figure 5).

1. Turn off everything powered through the fuse.
2. Disconnect other loads powered through the fuse:
 - Motors: disconnect motor connector (Connector C4 in Figure 5).
 - Lights: remove bulbs.
3. Turn Ignition Switch to RUN (if necessary) to power fuse.
4. Connect one Test Lamp lead to hot end of blown fuse. Connect other lead to ground. Bulb should glow, showing power to fuse. *(This step is just a check to be sure you have power to the circuit.)*
5. Disconnect the test lamp lead that is connected to ground, and reconnect it to the load side of the fuse at the connector of the disconnected component. (In Figure 5, connect the test lamp lead to connector C4.)
 - If the Test Lamp is off, the short is in the disconnected component.
 - If the Test Lamp goes on, the short is in the wiring. You must find the short by disconnecting the circuit connectors, one at a time, until the Test Lamp goes out. For example, in Figure 5 with a ground at X, the bulb goes out when C1 or C2 is disconnected, but not after disconnecting C3. This means the short is between C2 and C3.

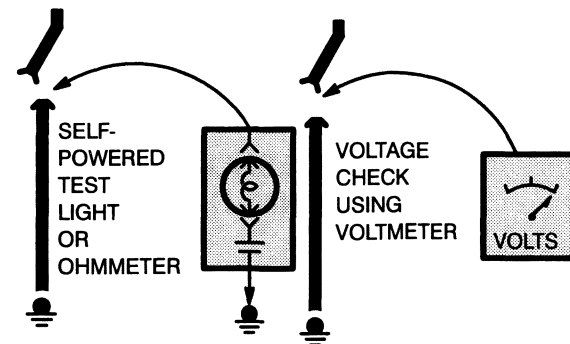

Figure 6—Ground Check

Turn on power to the circuit. Perform a Voltage Check between the suspected inoperative ground and the frame. Any indicated voltage means that the ground is inoperative (Figure 6).

Turn off power to the circuit. Connect one lead of a Self-Powered Test Lamp or Ohmmeter to the wire in question and the other lead to a known ground. If the bulb glows, the circuit ground is OK (Figure 6).

The circuit schematics in this manual make it easy to identify common points in circuits. This knowledge can help narrow the concern to a specific area. For example, if several circuits fail at the same time, check for a common power or ground connection (see *Power Distribution* or *Grounds*). If part of a circuit fails, check the connections between the part that works and the part that doesn't work.

For example, if the lo beam headlamps work, but the high beams and the indicator lamp don't work, then power and ground paths must be good. Since the dimmer switch is the component that switches this power to the high beam lights and indicator, it is most likely the cause of failure.

100% GUARANTEED

BUY IT NOW!

Click Here To Order

ck

PayPal, American Express, Discover, MasterCard, VISA

2-5 HOW TO USE THIS MANUAL

1995 BRONCO

TROUBLESHOOTING WIRING HARNESS AND CONNECTOR HIDDEN CONCERNS

The following illustrations are known examples of wiring harness, splices and connectors that will create intermittent electrical concerns. The concerns are hidden and can only be discovered by a physical evaluation as shown in each illustration.

NOTE: When servicing gold plated terminals in a connector, only replace with the gold plated terminals designed for that connector.

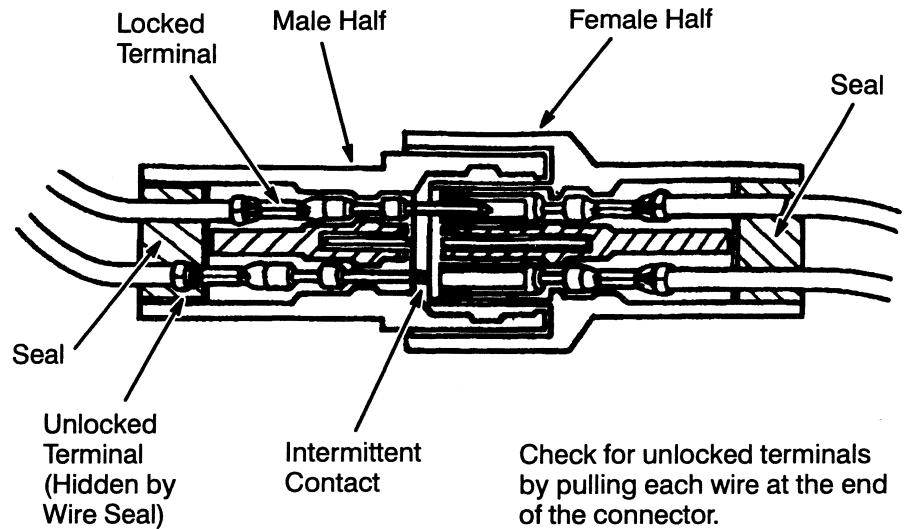

TERMINAL NOT PROPERLY SEATED

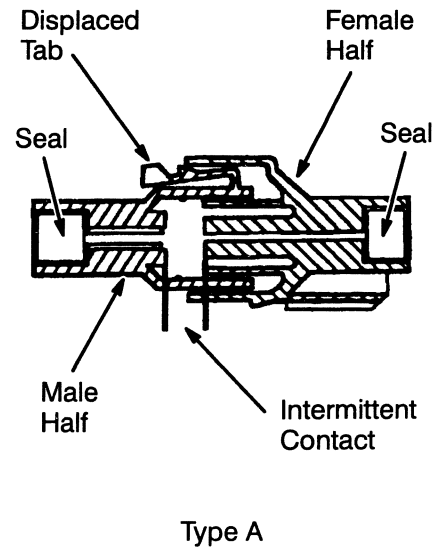
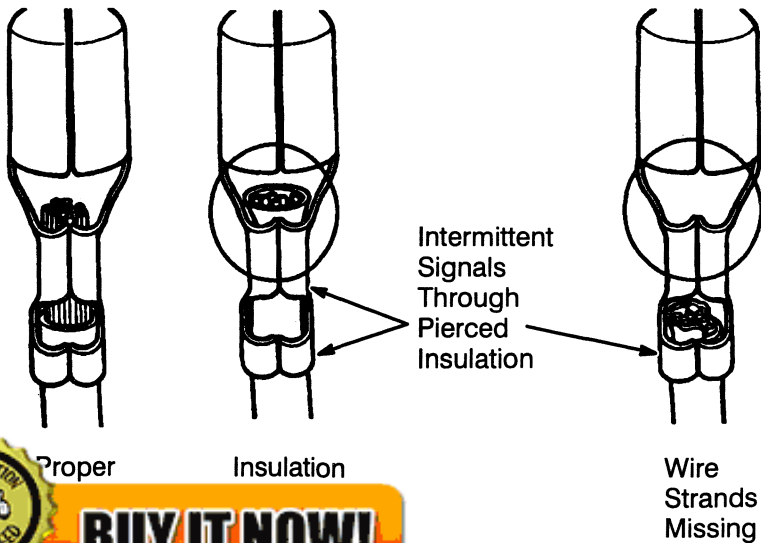

Lock may be displaced into an unlocked position; pull on the connector to verify the lock.

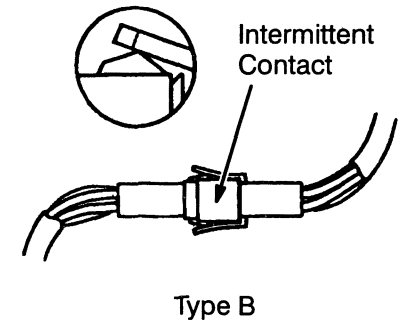

PARTIALLY MATED CONNECTORS

100% SATISFACTION GUARANTEED

BUY IT NOW!

Click Here To Order

ON STRIPPING

PayPal, American Express, Discover, MasterCard, VISA

HOW TO USE THIS MANUAL 2-6

1995 BRONCO

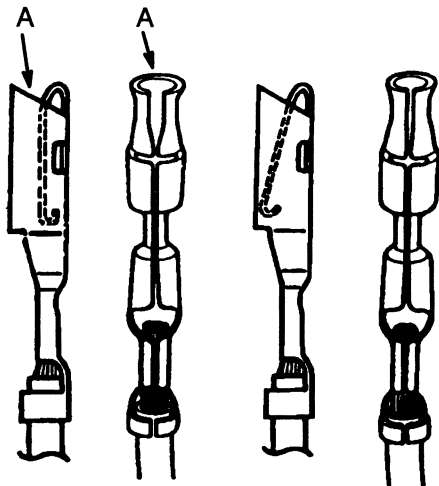

Enlarged

Normal

Any probe entering the terminal may enlarge the contact spring opening creating an intermittent signal. Insert the correct mating terminal (Location A) from the service kit and feel for a loose fit.

DEFORMED (ENLARGED) FEMALE TERMINALS

Solder Coated Wire to Ground

Solder coated wire pierced through the insulation of another circuit.

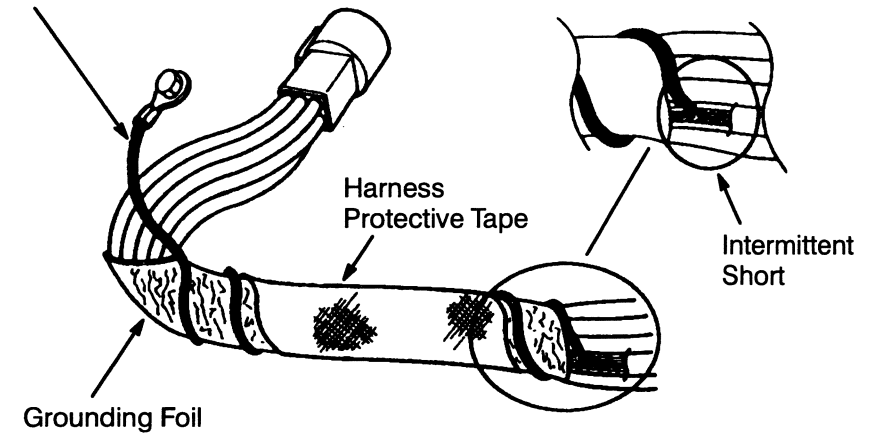

ELECTRICAL SHORT INSIDE THE HARNESS

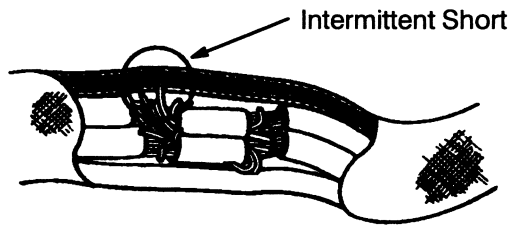

Splice Tape Removed

Operate the system and flex the harness at splice location noted in Section 152.

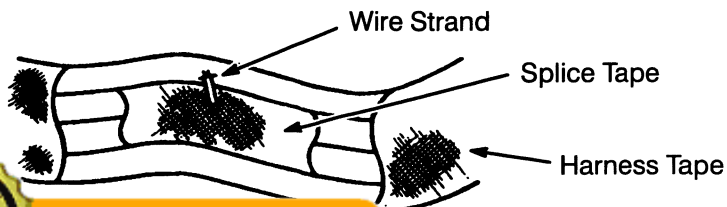

100% SATISFACTION GUARANTEED

BUY IT NOW!

Click Here To Order

SHORT WITHIN THE HARNESS

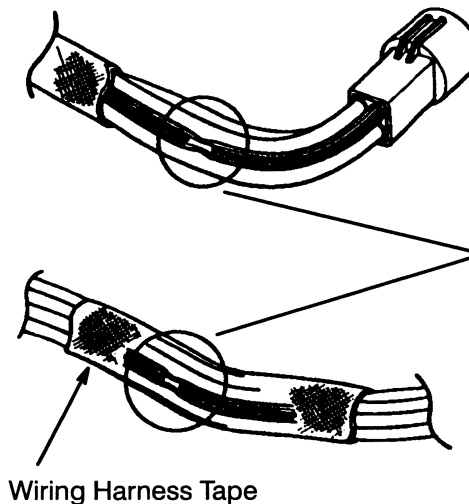

Wiring Harness Tape

Remove the tape and flex/feel each circuit for a reduction in diameter at break.

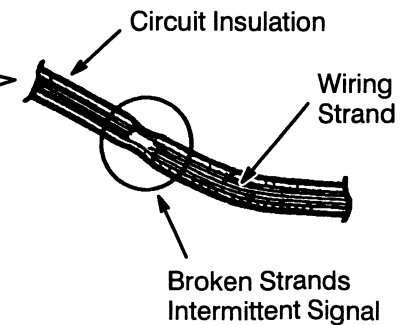

Broken Strands Intermittent Signal

BROKEN WIRE STRANDS IN HARNESS

2-7 HOW TO USE THIS MANUAL

1995 BRONCO

HOW TO FIND THE VACUUM CONCERNS

These six steps present an orderly method of troubleshooting.

Step 1. Verify the concern.

- Operate the system and observe all symptoms to check the accuracy and completeness of the customer's complaint.

Step 2. Narrow the concern.

- Narrow down the possible causes and locations of the concern to pinpoint the exact cause.

Step 3. Test the suspected cause.

- Use test procedures to find the specific cause of the symptoms.

Step 4. Verify the cause.

- Confirm that you have found the right cause by operating the parts of the circuit you think are good.

Step 5. Make the repair.

- Repair or replace the inoperative component.

Step 6. Verify the repair.

- Operate the system as in Step 1. Check that your repair has removed all symptoms without creating any new symptoms.

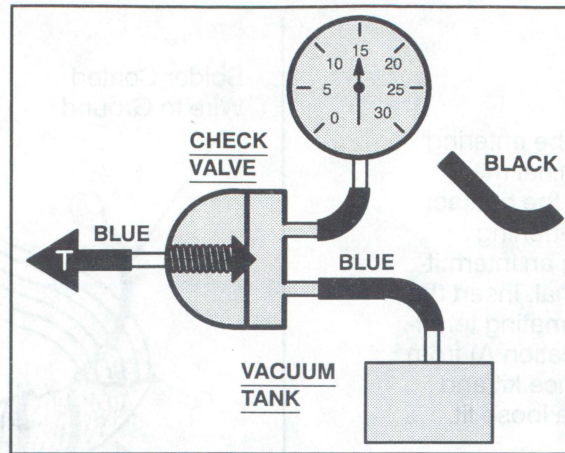

Figure 1 – System Supply Test

Vacuum Supply Test

1. Connect Vacuum Tester to system side of Check Valve (Figure 1).
2. Start engine. Gauge should show approximately 15 inches of vacuum.
3. Turn off engine, and observe gauge:
 - If vacuum holds, supply OK.
 - If vacuum fails, replace Check Valve or Tank.

Leak Test

1. Connect Vacuum Gauge and Vacuum Pump (Figure 2) to system hose in place of tank.
2. Open valve and start pump. Operate control in all modes.
3. Listen for hiss and observe gauge.

NOTE: Hissing is normal at Function Control when changing modes.

If system hisses or loses vacuum, find system leak as follows:

1. Turn on Vacuum Pump and check vacuum build-up.
2. Stop pump; vacuum should drop.
3. Clamp supply hoses with needlenose pliers, one at a time, until vacuum stops dropping (Figure 2).
4. Check vacuum schematic to find components in that line.
5. Clamp hoses through circuit to find leak.

Component Test

1. Connect Vacuum Tester to component.
2. Pump Vacuum Tester. Check that all components operate correctly and vacuum holds.
3. Replace component if vacuum does not hold.

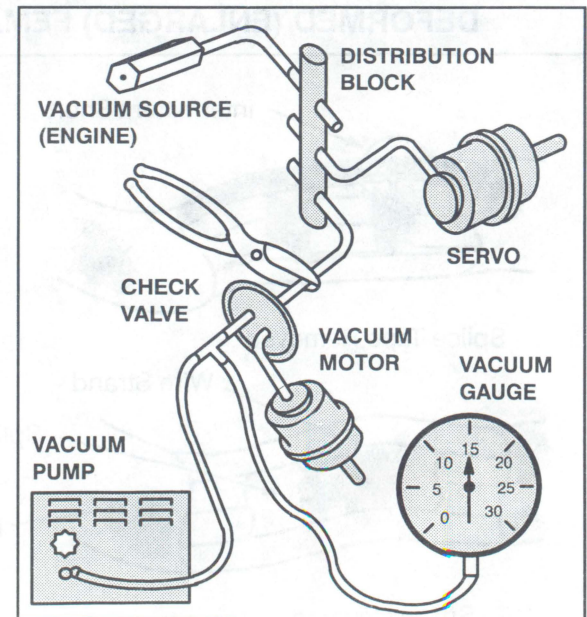

Figure 2 – Testing For Leaks In Typical Vacuum System

NOTE: Vacuum system problems fall into three groups.

1. Leaks in hoses, connectors or motor diaphragms.



BUY IT NOW!

Click Here To Order



ELECTRICAL SYMBOLS

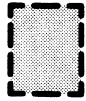

DASHED COMPONENT BOX
ONLY PART OF THE COMPONENT IS SHOWN ON THE PAGE; THE COMPONENT IS SHOWN COMPLETE IN ANOTHER LOCATION

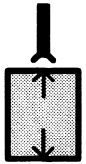

COMPONENT WITH CONNECTORS

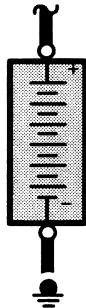

BATTERY

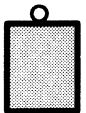

SCREW TERMINAL ON COMPONENT

SOLID STATE

SEALED ELECTRONIC COMPONENT
ANY CIRCUITRY SHOWN INSIDE THE BOX IS A FUNCTIONAL

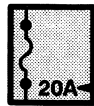

FUSE

CURRENT RATING

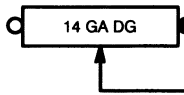

FUSIBLE LINK

WIRE SIZE AND COLOR

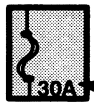

MAXI-FUSE or FUSIBLE LINK CARTRIDGE

CURRENT RATING

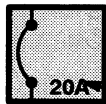

CIRCUIT BREAKER

CURRENT RATING

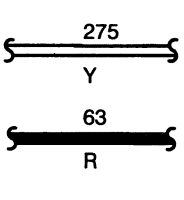

SOLID WIRES

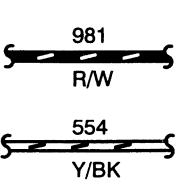

STRIPED WIRES

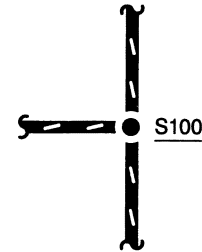

SPLICE OR CRIMP TERMINAL

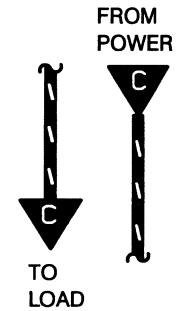

"CUT" WIRES REFERENCED BETWEEN PAGES
ARROWS SHOW CURRENT FLOW FROM POWER TO GROUND



BACKUP LIGHTS

"REFERENCE" WIRES
COMPLETE WIRING SHOWN ON ANOTHER PAGE

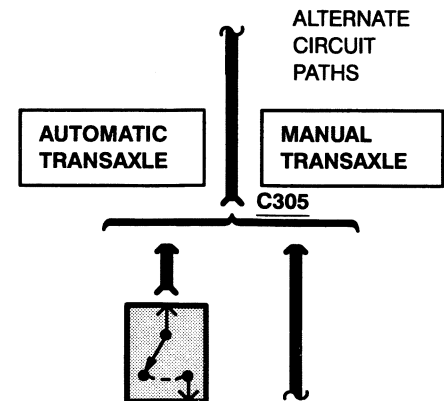

100% SATISFACTION GUARANTEED

BUY IT NOW!

Click Here To Order

2-9 HOW TO USE THIS MANUAL

1995 BRONCO

ELECTRICAL SYMBOLS

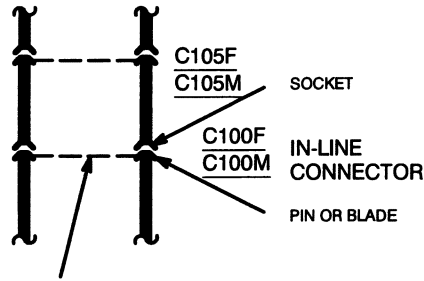

SINGLE DASHED LINE INDICATES THAT WIRE ON LEFT ALSO PASSES THROUGH THE SAME CONNECTOR

SEE GROUNDS
PAGES 10-1,
10-2



DASHED WIRE
CIRCUITRY IS NOT
SHOWN IN COMPLETE
DETAIL, BUT IS
COMPLETE
ON ANOTHER PAGE

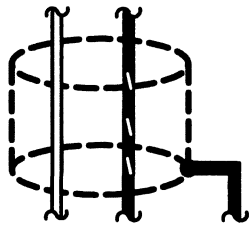

SHIELD
WIRES ARE
COVERED
BY A SHIELD

FIELD COIL

100% SATISFACTION GUARANTEED

BUY IT NOW!

Click Here To Order



MOTOR



HEATING
ELEMENT



THERMISTOR



RHEOSTAT
OR
POTENTIOMETER



SOLENOID

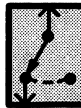

SWITCH

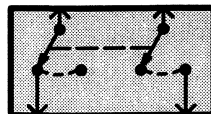

GANGED
SWITCHES
CONTACTS MOVE
AT THE SAME TIME

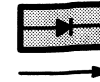

DIODES
CURRENT FLOWS
IN DIRECTION OF
ARROW ONLY

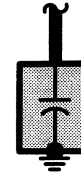

CAPACITOR



TRANSISTOR



GAUGE



LIGHT
EMITTING
DIODE
(LED)



LIGHT
BULB

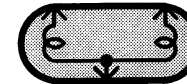

DUAL FILAMENT
LIGHT BULB

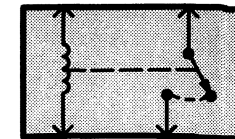

RELAY
CONTACTS
CHANGE POSITION
WITH CURRENT
THROUGH COIL

VACUUM SYMBOLS

"T" JUNCTION

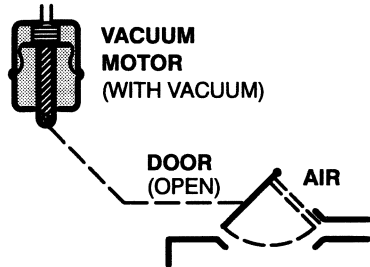

VACUUM ON VACUUM MOTOR PULLS DOOR OPEN TO LET AIR PASS THROUGH

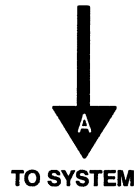

TO SYSTEM

FROM VACUUM DISTRIBUTION



"CUT" HOSES REFERENCED BETWEEN PAGES
ARROW SHOWS FROM MANIFOLD FITTING TO COMPONENT

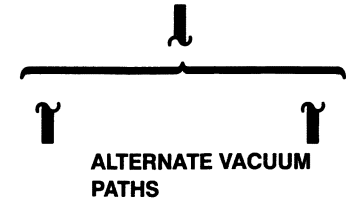

ALTERNATE VACUUM PATHS

NOTE

Other vacuum symbols used on vacuum system diagrams are fully explained on the pages where they appear.

VACUUM MOTOR OPERATION

SINGLE DIAPHRAGM MOTOR

NO VACUUM



VACUUM



SERVO MOTOR

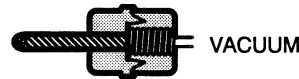

Some vacuum motors can position the actuating arm at any position between fully extended and fully retracted. The Servo is operated by a control valve that applies varying amounts of vacuum to the motor. The higher the vacuum level, the greater the retraction of the motor arm. Servo Motors work nearly the same way as two-position motors, except for the way the vacuum is applied. Servo Motors are generally larger and provide a calibrated control.

DOUBLE DIAPHRAGM MOTOR

NO VACUUM



NO VACUUM



NO VACUUM

VACUUM



VACUUM

A double diaphragm motor has three positions (it is actually two motors in one housing). When the top port gets vacuum, the shaft pulls halfway in. When both ports get vacuum, the shaft pulls all the way in.

Satisfaction 100% Guaranteed

BUY IT NOW!

Click Here To Order

10-1 GROUND

1995 BRONCO

All circuits are 57 BK unless otherwise noted.

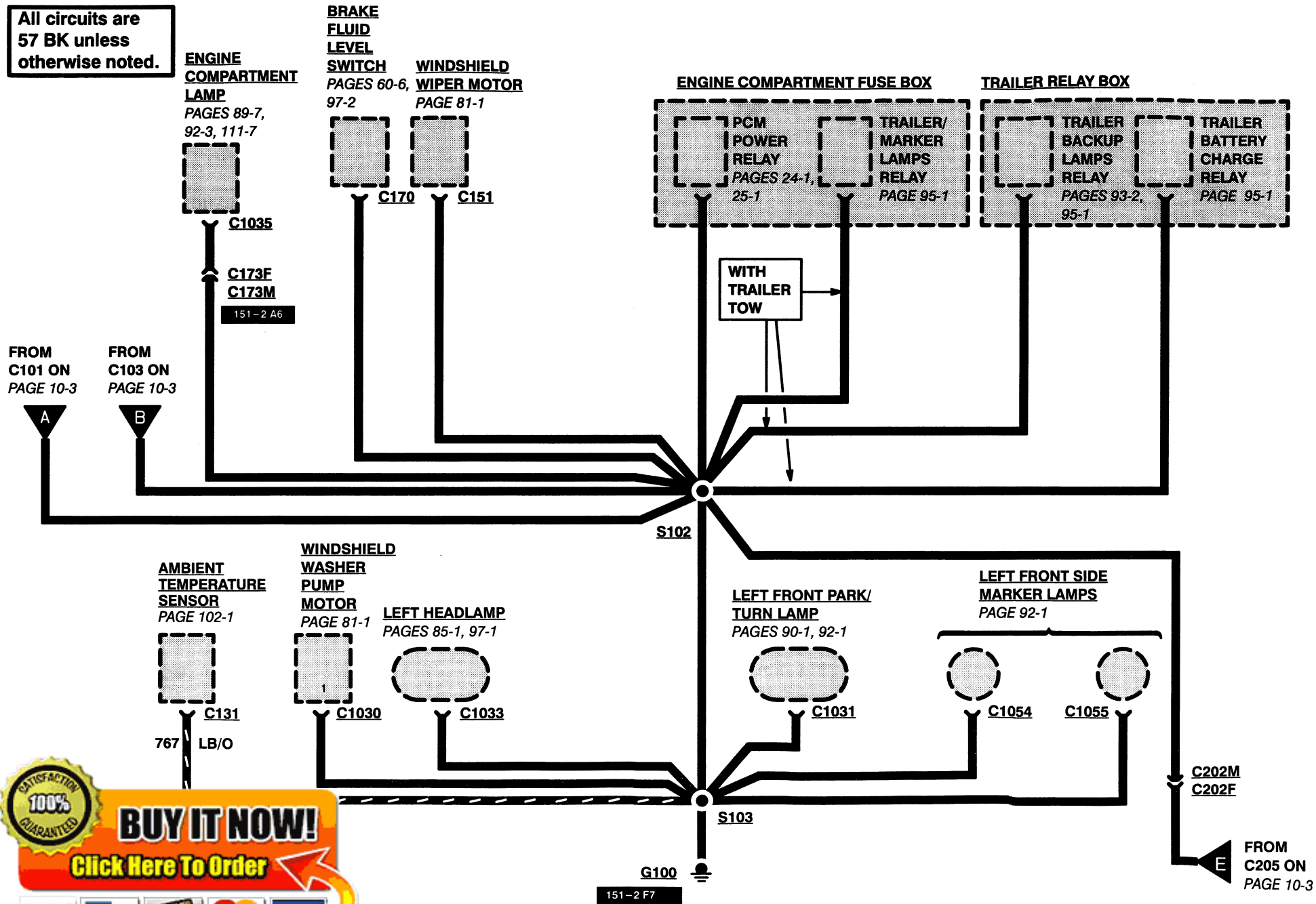

100% SATISFACTION GUARANTEED

BUY IT NOW!

Click Here To Order

PayPal | American Express | Discover | MasterCard | VISA

151-2 F7

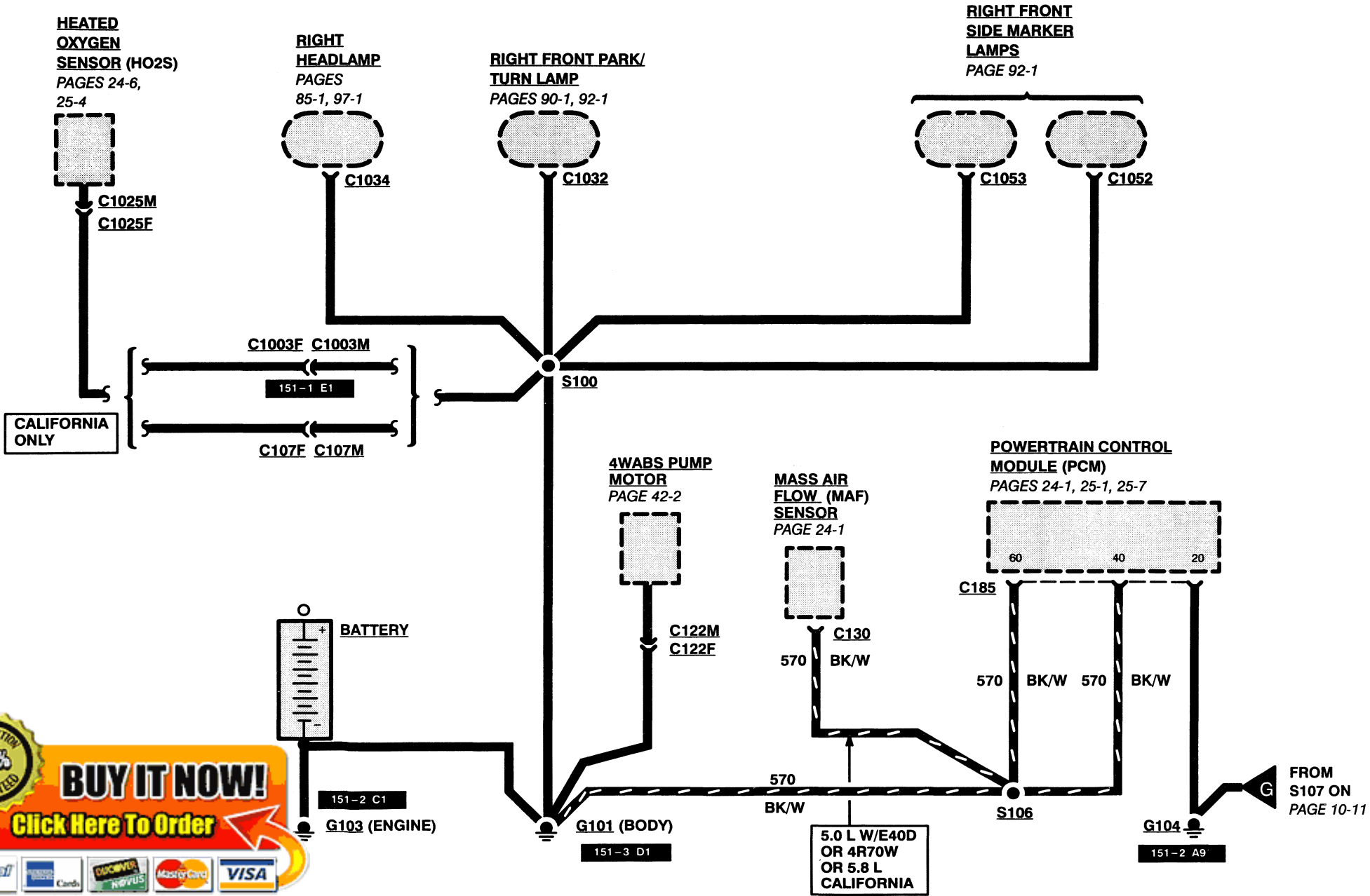

100% SATISFACTION GUARANTEED

BUY IT NOW!

Click Here To Order

PayPal American Express Discover MasterCard VISA

10-3 GROUNDS

1995 BRONCO

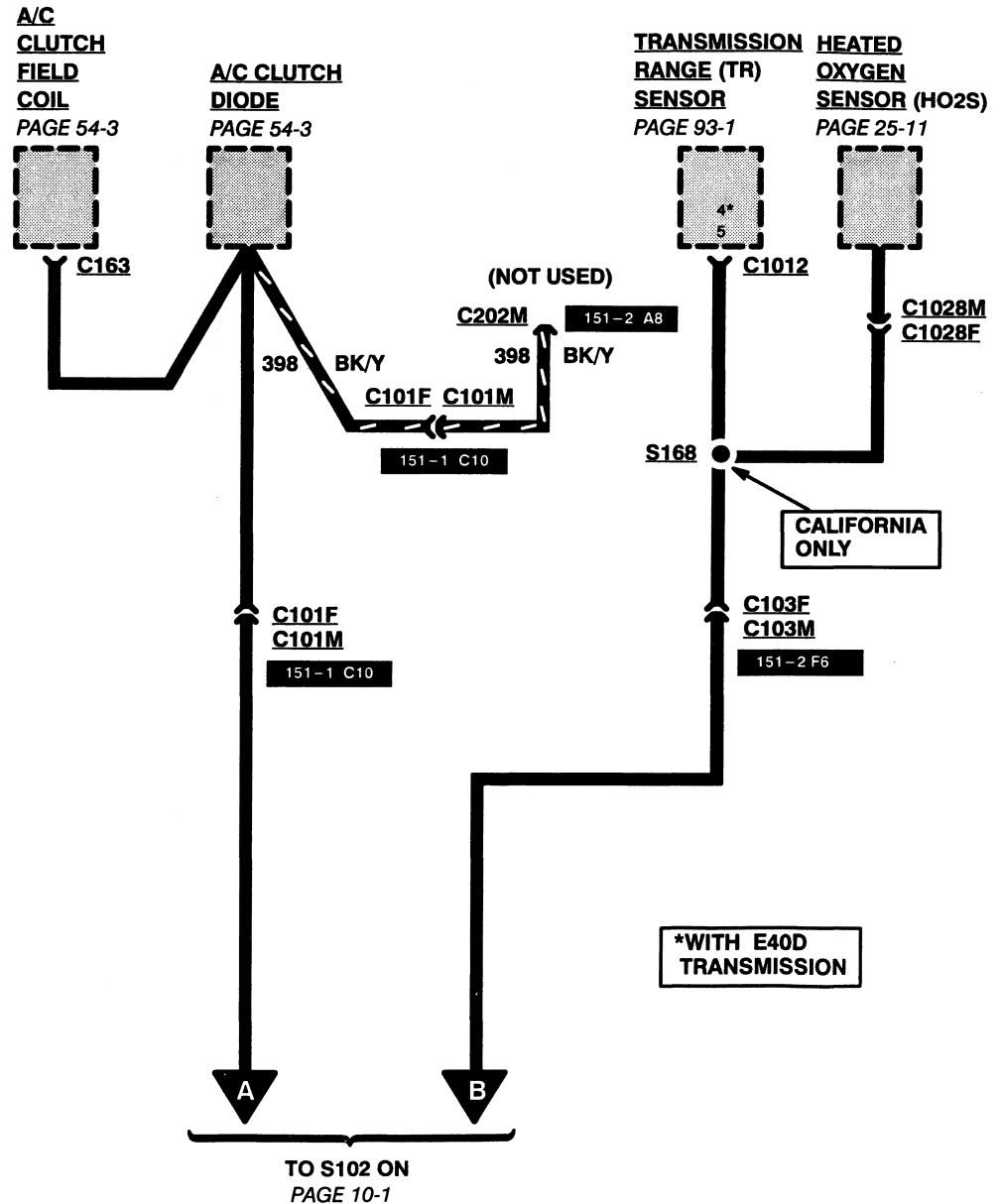
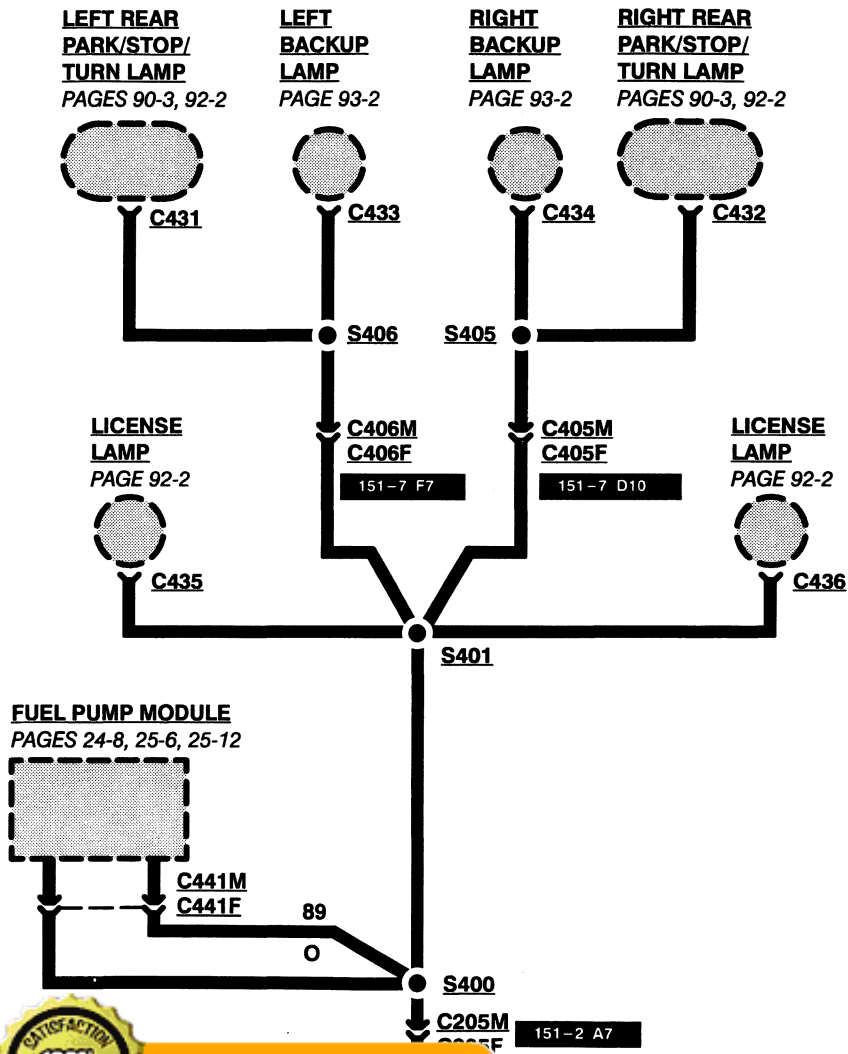

100% SATISFACTION GUARANTEED

BUY IT NOW!

Click Here To Order

PayPal, American Express, Discover, MasterCard, VISA

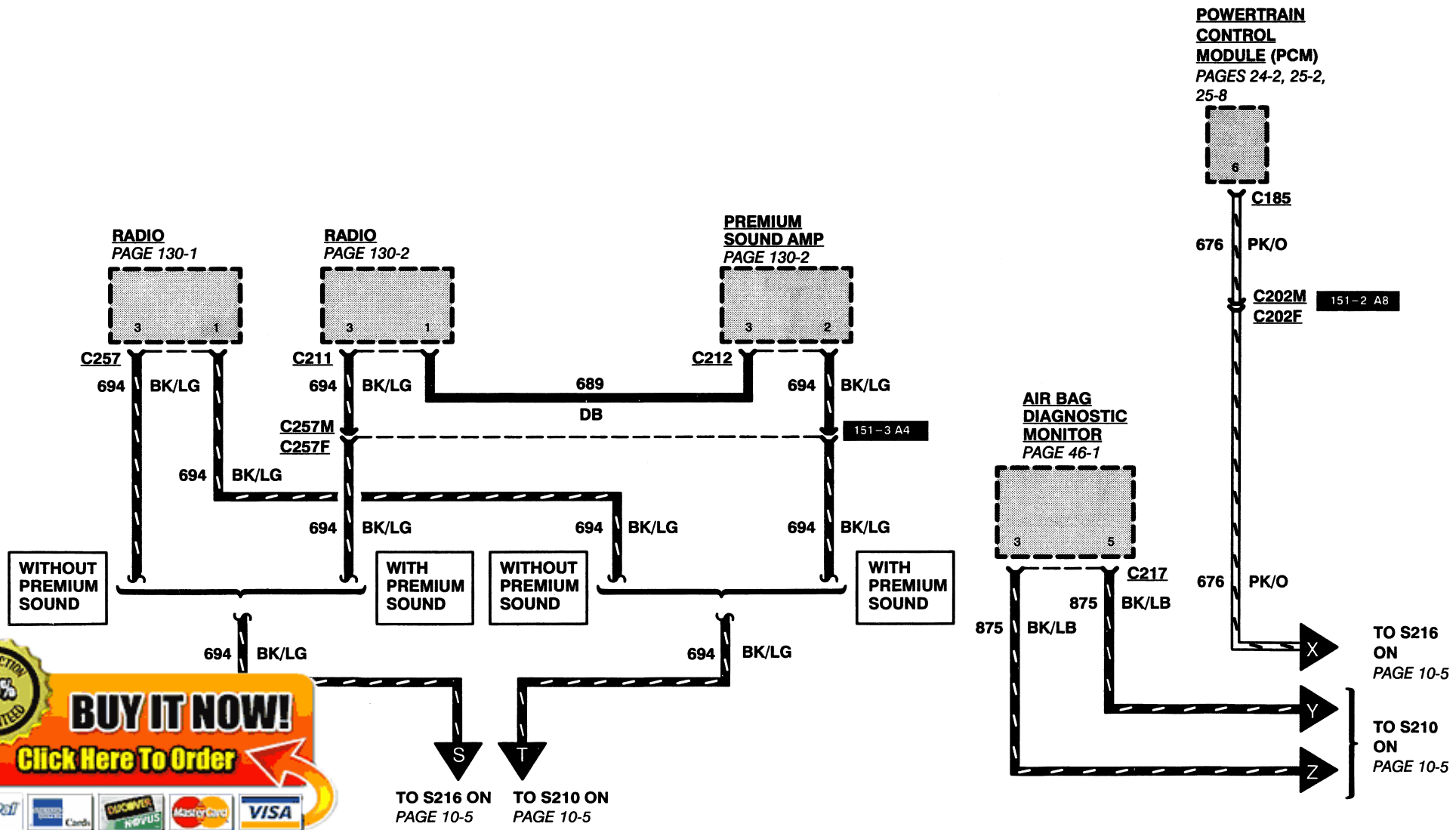

100% SATISFACTION GUARANTEED

BUY IT NOW!

Click Here To Order

PayPal, American Express, Discover, MasterCard, VISA

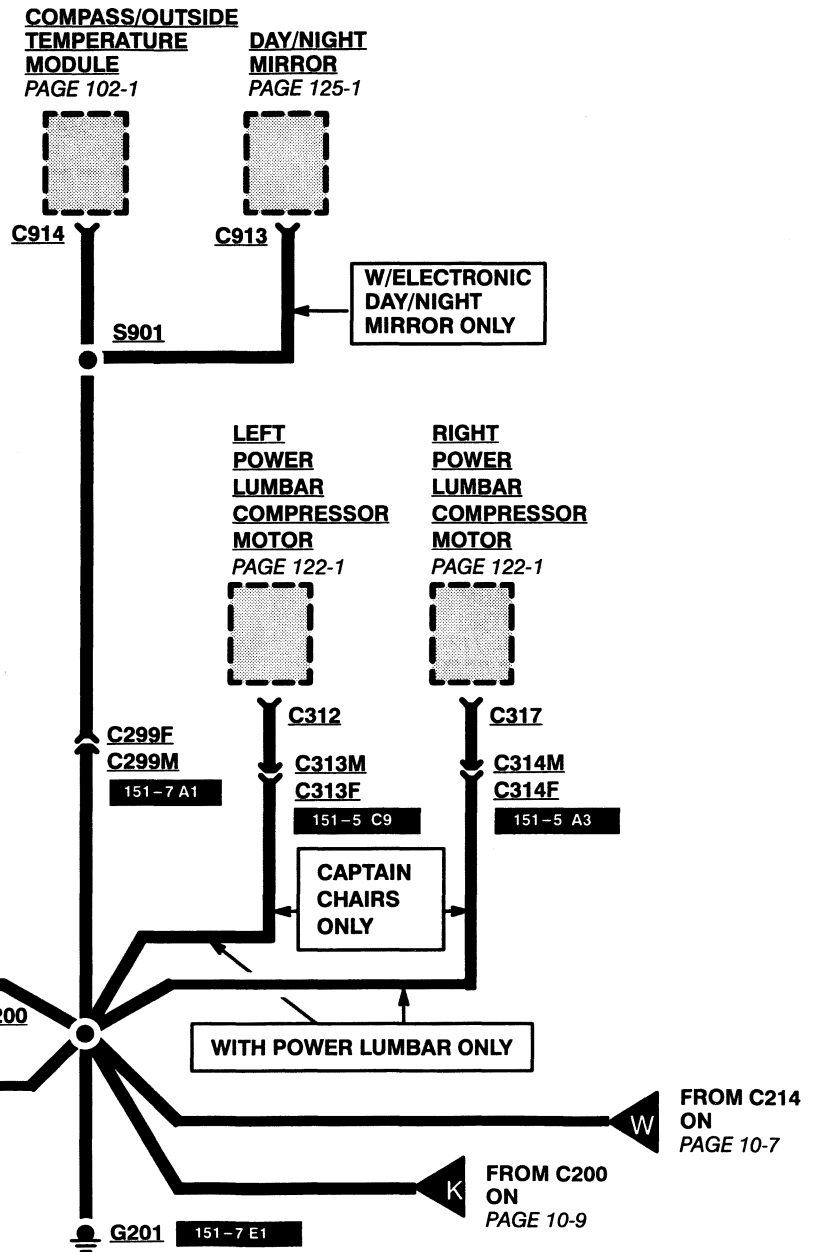

100% SATISFACTION GUARANTEED

BUY IT NOW!

Click Here To Order

PAGES 89-6, 111-6

INSIDE CARGO LAMP PAGES 89-6, 111-6

10-7 GROUND

1995 BRONCO

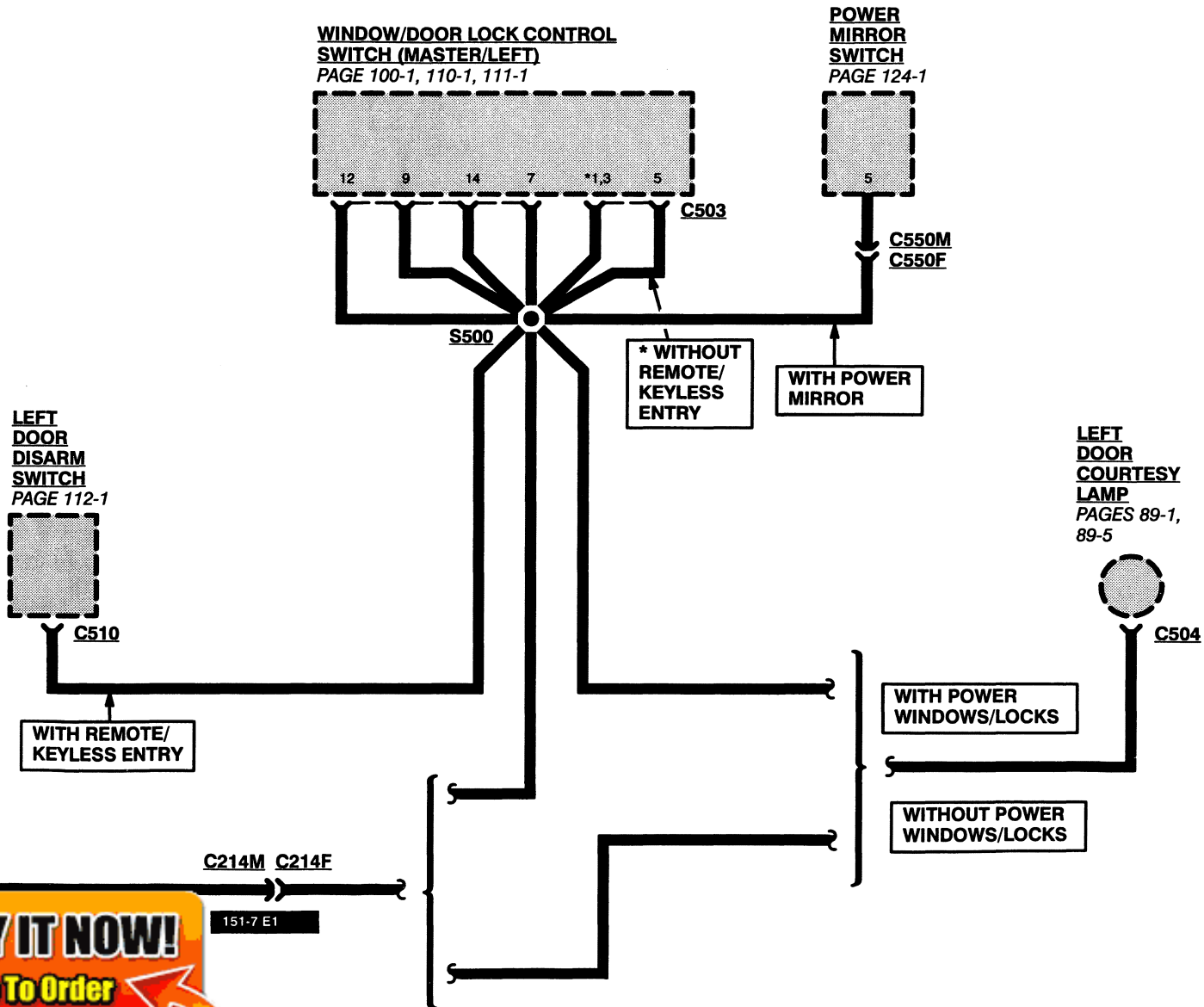

100% SATISFACTION GUARANTEED

BUY IT NOW!

Click Here To Order

PayPal American Express Cards Discover Novus MasterCard VISA

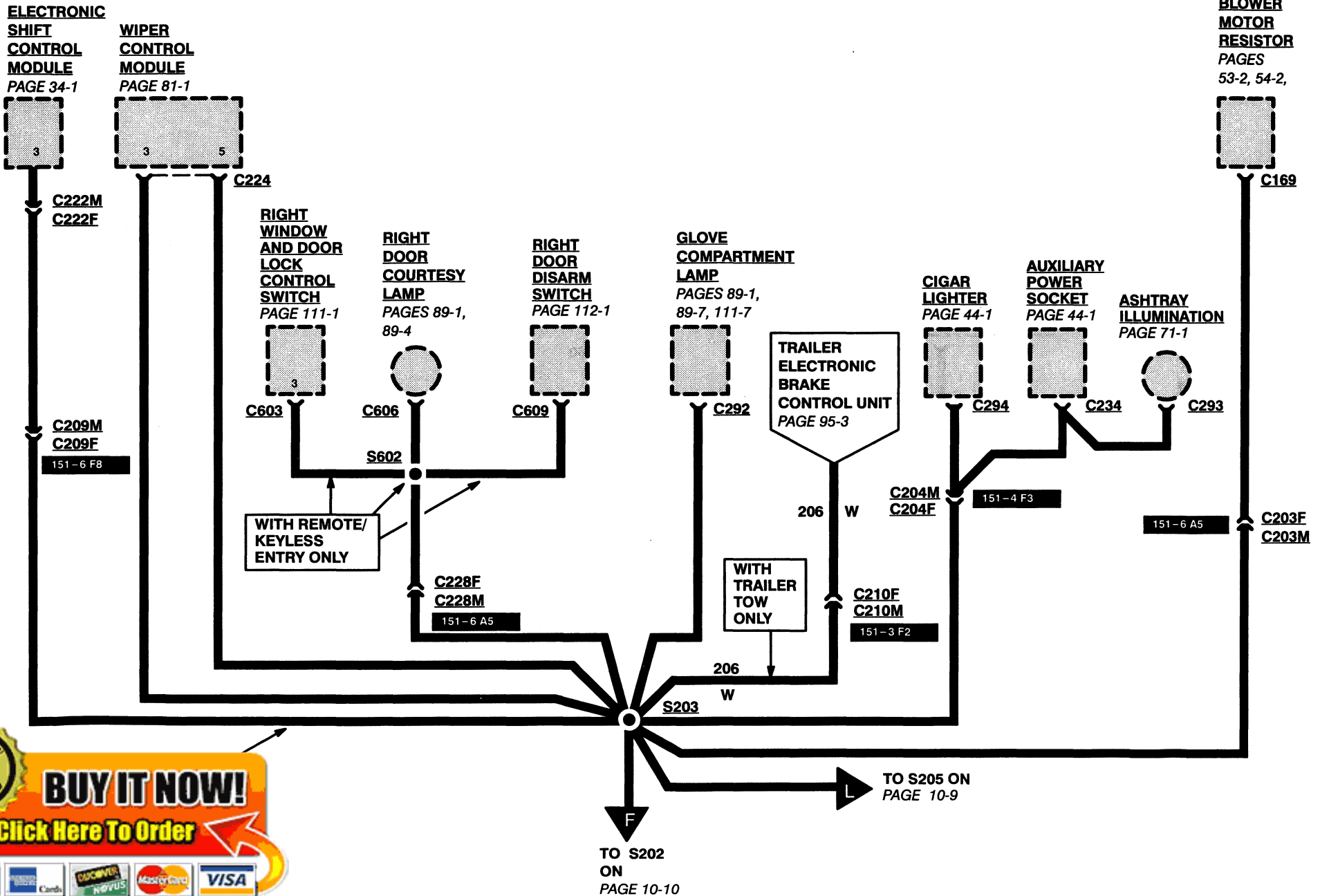

100% SATISFACTION GUARANTEED

BUY IT NOW!

Click Here To Order

PayPal, American Express, Discover, MasterCard, VISA

10-9 GROUNDS

1995 BRONCO

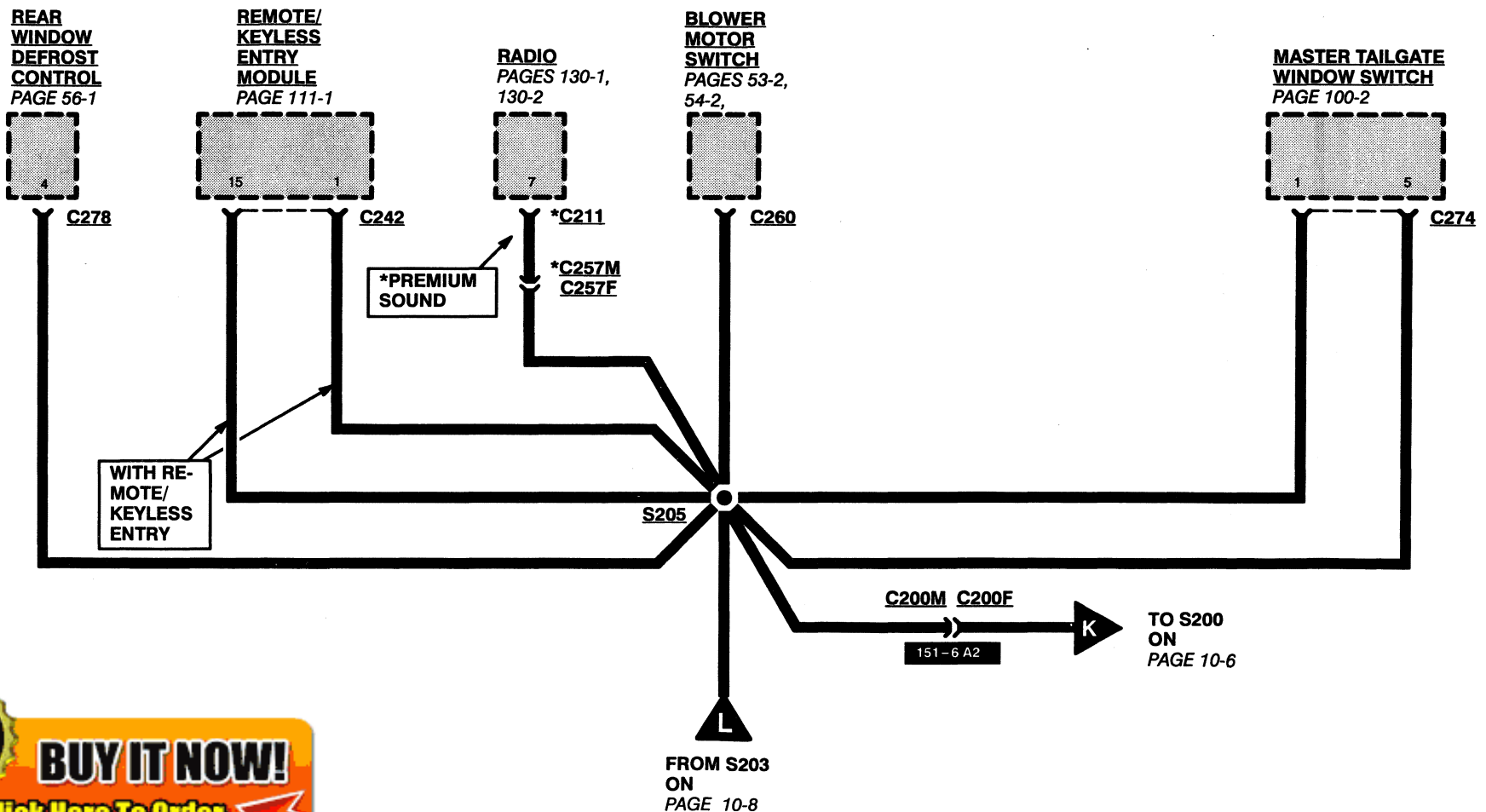

100% SATISFACTION GUARANTEED

BUY IT NOW!

Click Here To Order

PayPal American Express Discover MasterCard VISA

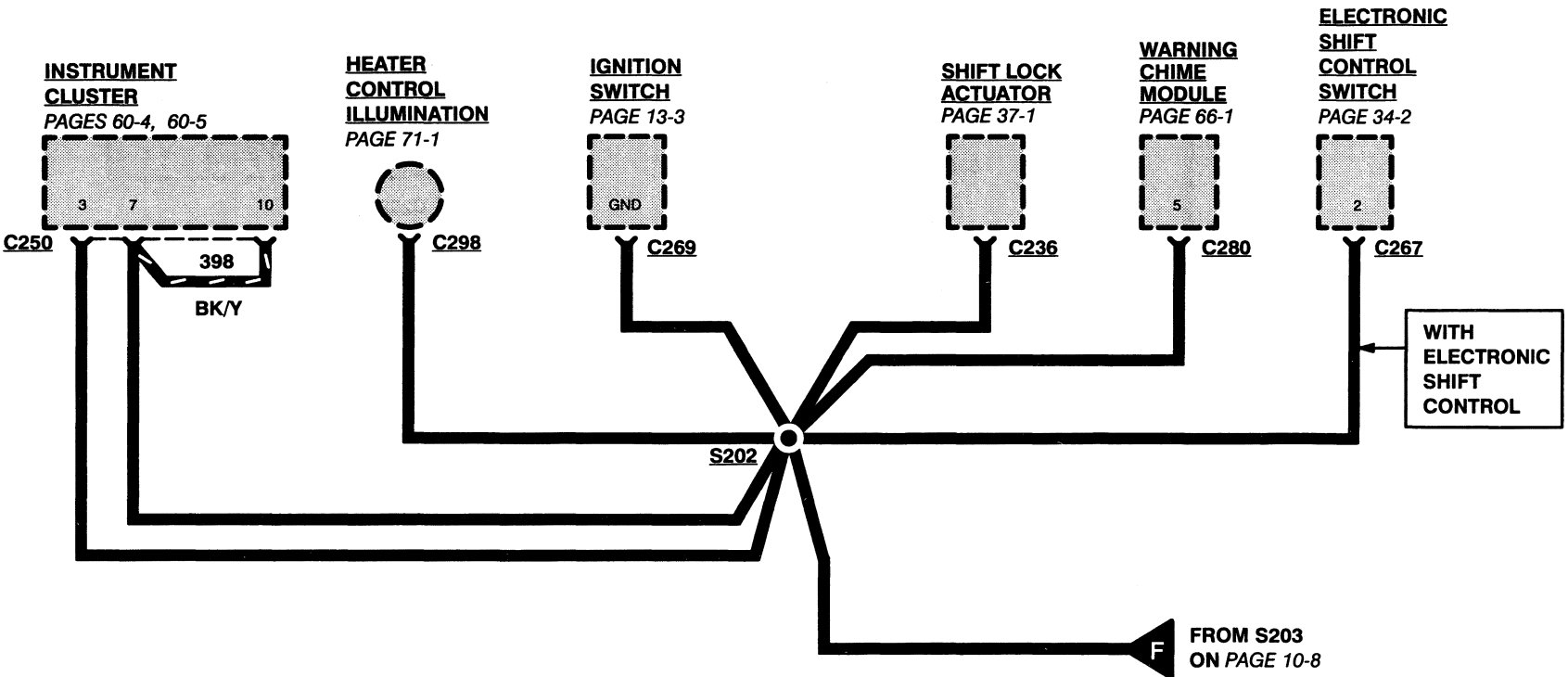

100% SATISFACTION GUARANTEED

BUY IT NOW!

Click Here To Order

PayPal

Discover

MasterCard

VISA

NOTES 10-12

1995 BRONCO

SATISFACTION 100% GUARANTEED

BUY IT NOW!

Click Here To Order

PayPal American Express Discover MasterCard VISA

11-1 FUSE PANEL/CIRCUIT PROTECTION

1995 BRONCO

CIRCUIT PROTECTION DEVICES

Electrical circuits on this vehicle may be protected by fuses, fusible links, fusible link cartridges, circuit breakers, or a combination of these devices.

BLADE TYPE FUSE

TOP VIEW

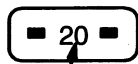

AMPERE RATING

SIDE VIEW

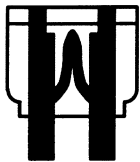

GOOD FUSE

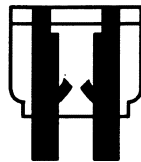

BLOWN FUSE

Blade type fuses have a transparent plastic housing. To check a fuse, pull it from the fuse panel and look at the fuse element through the housing. Always replace a blown fuse with a new fuse that has the same ampere rating.

The ampere rating of a blade type fuse can also be determined by following the color code shown here:

BLADE FUSE COLOR CODING	
AMPERE RATING	HOUSING COLOR
4	Pink
5	Tan
10	Red



BUY IT NOW!

Click Here To Order

FUSIBLE LINK

CUT-AWAY VIEW

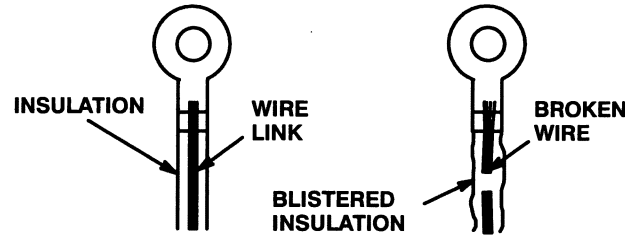

GOOD LINK

BLOWN LINK

Fusible links are short lengths of wire that are smaller in diameter than the wires they are protecting. Fusible link wire is covered with a special thick, non-flammable insulation. An overload condition causes the insulation to blister. If the overload condition continues, the wire link will melt. To check a fusible link, look for blistered insulation. If the insulation is okay, pull lightly on the wire. If the fusible link stretches, the wire has melted.

When replacing fusible links, first cut the protected wire where it is connected to the fusible link. Then, tightly crimp or solder the new link to the protected wire.

Fusible links are often identified by color coding of the insulation, as shown here:

FUSIBLE LINK COLOR CODING	
WIRE LINK SIZE	INSULATION COLOR
20 GA	Blue
18 GA	Brown or Red
16 GA	Black or Orange
14 GA	Green
12 GA	Gray

FUSIBLE LINK CARTRIDGE

SIDE VIEW

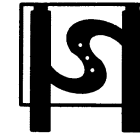

GOOD



BLOWN

TOP VIEW

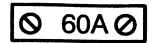

AMPERE RATING

Fusible link cartridges have a transparent colored plastic housing. To check a fusible link cartridge, look at the fuse element through the side of the housing.

To replace a fusible link cartridge, pull it from the fuse box or panel. Always replace a blown fusible link cartridge with a new one having the same ampere rating.

The ampere rating of a fusible link cartridge can also be determined by following the color code shown here:

FUSIBLE LINK CARTRIDGE COLOR CODING	
AMPERE RATING	HOUSING COLOR
30	Light Green
40	Amber
50	Red
60	Blue



CIRCUIT BREAKER

Some circuits are protected by circuit breakers (abbreviated "c. b." in fuse chart). They can be Fuse Panel mounted or in-line. Like fuses, they are rated in amperes.

Each circuit breaker conducts current through an arm made of two types of metal bonded together (bimetal arm). If the arm starts to carry too much current, it heats up. As one metal expands faster than the other, the arm bends, the contacts open and current flow is broken. A circuit breaker can be the cycling or non-cycling type.

In the cycling type, the bimetal arm cools and straightens out. This cycle repeats as long as the overcurrent exists and power is applied.

In the first type, there is a coil wrapped around the bimetal arm. When an overcurrent exists and the contacts open, a small current passes through the coil. This current through the coil is not enough to operate a load, but it does heat up both the coil and the bi-metal arm. This keeps the arm in the open position until power is removed.

In the second type, a spring pushes the bimetal arm down and holds the contacts together. When an overcurrent condition exists and the bimetal arm heats up, the bimetal arm bends enough to overcome the spring and the contacts snap open. The contacts stay open until the reset button is pushed and the contacts snap together again.

FUSE PANEL MOUNTED NON-CYCLING TYPE

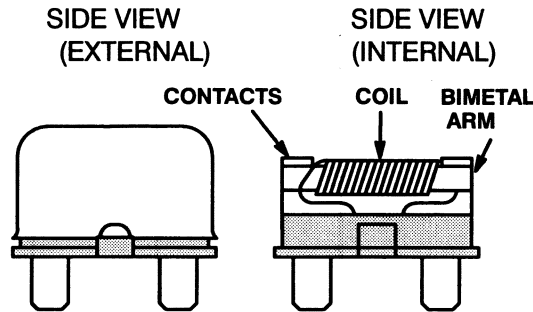

FUSE PANEL MOUNTED MANUAL RESET TYPE

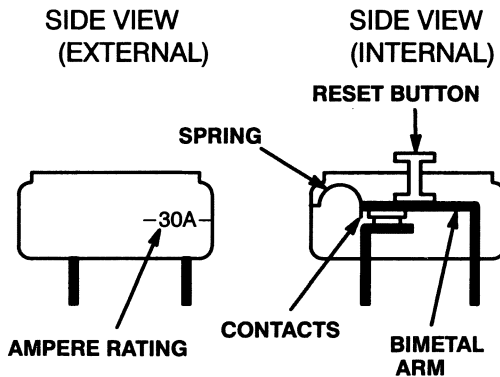

Two types of non-cycling circuit breakers are used: one is reset by removing power from the circuit, and the other is reset by depressing a reset button.

FUSE PANEL MOUNTED CYCLING TYPE

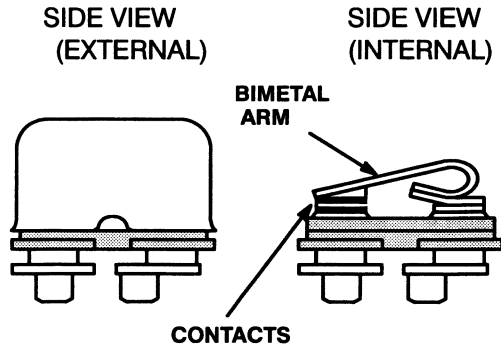

IN-LINE MOUNTED CYCLING TYPE

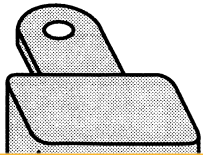

DIODE



Diodes are electrical devices that permit current to flow in one direction only. The current flows in the direction indicated by the arrow.

100% SATISFACTION GUARANTEED

BUY IT NOW!

Click Here To Order

11-3 FUSE PANEL/CIRCUIT PROTECTION

1995 BRONCO

INSTRUMENT PANEL FUSE PANEL

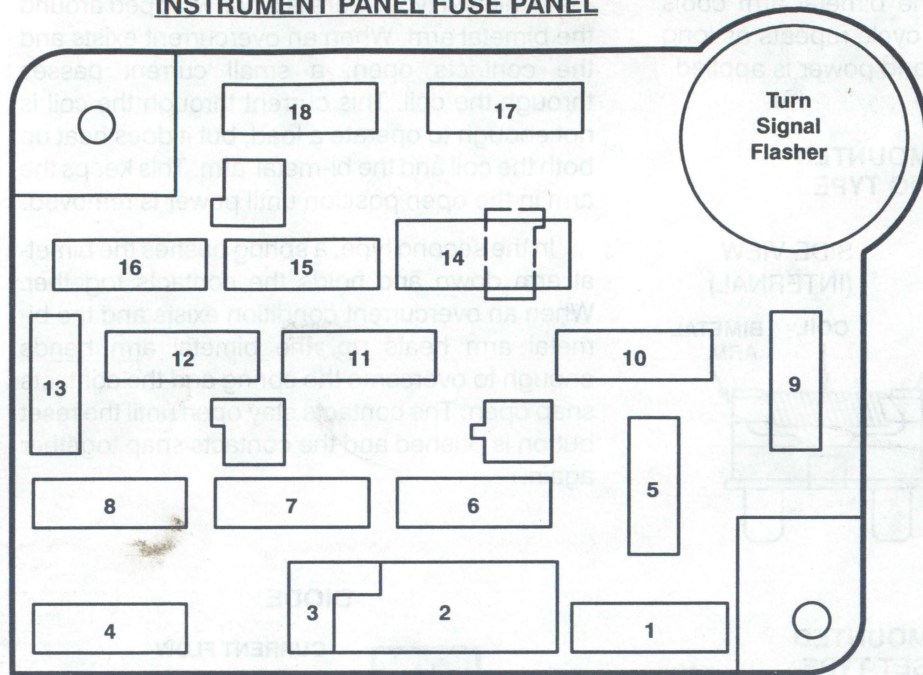

Fuse Position	Amps	Circuits Protected
1	30	Air Conditioner/Heater
2	30	Interval Wiper/Washer
3	—	(Not Used)
4	15	Exterior Lamps, Remote/Keyless Entry, Warning Chime, Instrument Illumination
5	10	Air Bag Module
6	15	Anti-theft, Remote/Keyless Entry, Air Conditioner/Compressor Clutch
7	15	Turn Lamps, Rear Window Defrost
8	15	Courtesy Lamps, Engine Compartment Lamp, Power Mirrors, Vanity Mirrors, Speedometer Memory, Warning Chime, Keyless Entry
9	25	Power Point
10	4	Instrument Illumination
11	15	Radio, Radio Display Dim
12	20 c.b.	Power Door Lock, Power Tailgate Window, Electronic Shift Control, Power Lumbar
13	15	Stop and Hazard Lamps, Stop Sense For: Anti-lock Brakes, Speed Control, PCM
14	20 c.b.	Power Windows
15	—	(NOT USED)
16	15	Cigar Lighter
17	10	Trans Control Indicator Lamp and Switch, Warning Chime, Instrument Cluster, Electronic Shift Control Switch Lamps
18	10	Speedometer, Electronic Shift Control, Air Bag Module, Day/Night Mirror, Overhead Console

Fuse Value Amps	Color Code
4	Pink
5	Tan
10	Red
15	Light Blue
20	Yellow
25	Natural
30	Light Green

Power Distribution

The Generator and Battery are connected together at the Starter Relay hot terminal. Other circuits originate at the Starter Relay hot terminal and are protected by fuse links. Low power circuits are also protected by fuses.

The Ignition Switch and Main Light Switch are powered at all times, as are fuses 4, 5, 8, 9, 12, 13 and 16. The other fuses are powered through the Ignition Switch or the Main Light Switch.

100% SATISFACTION GUARANTEED

BUY IT NOW!

Click Here To Order

COMPONENT LOCATION 152-12

1995 BRONCO

Connector	Location	Page	Connector	Color	Terminal
		Zone	Page		
C278	Behind top LH side of I/P, on rear window defrost control	*	56-2	N	5
C279	Behind LH side of I/P, on brake ON/OFF switch	151-3 F7		BK	2
C280	Behind lower center of I/P, on warning chime module	151-4 F6	66-2	GY	7
C282	Behind center of I/P, on radio	151-3 A3	130-6		8
C283	Behind center of I/P, on premium sound amplifier	151-4 A5	130-6		8
C292	Behind RH side of I/P, on glove compartment lamp	151-4 B1		BR	2
C293	Behind lower center of I/P, on ashtray illumination	151-4 F5		BK	2
C294	Behind lower center of I/P, on cigar lighter	151-4 F4			1
C295	Below lower center of I/P, on cigar lighter	151-4 F4		BK	1
C296 (With A/C)	Behind center of I/P, on A/C-heater control assembly	151-4 A2		W	4
C296 (Without A/C)	Behind center of I/P, on heater control assembly	151-4 A2		W	4
C298	Behind center of I/P, on heater control illumination	151-4 A4		BK	2
C299	At base of LH "A" pillar	151-7 A1	150-11		8
C300	At base of LH "B" pillar	151-7 A2		GY	4
C302	Below RH side of LH front seat, to seat belt switch	151-7 A3		GY	2
C305	Under LH side of LH front seat, to left power lumbar switch	151-5 F8		GY	2
C306	Under RH side of RH front seat, to right power lumbar switch	151-5 D1		GY	2
C310	LH side of tailgate, near rear window, on rear window defrost grid	151-6 A8		BK	1
C311	Center of tailgate, near rear window, on rear window defrost grid	151-6 A7		BK	1
C312	Under front of LH seat, on left power lumbar motor	151-5 F6		BK	2
C313	Below LH front seat	151-5 C9		GY	2
C314	Below RH front seat	151-5 A3		GY	2
C315	At base of LH "B" pillar	151-7 F3		BR	4
C317	Under front of RH front seat, on right power lumbar motor	151-5 F3		BK	2
C318	LH rear of cargo area, near center of "D" pillar	151-7 F6	150-11	BR	6
C326	LH side of cargo area, on left rear speaker	151-7 A3		GY	2
	RH side of cargo area, on right rear speaker	151-7 B10		GY	2
	Mounted on RH side of frame rail, on safing sensor	151-7 C10			5
	Mounted on LH side of frame rail, to left crash sensor	151-1 F9			4

100% SATISFACTION GUARANTEED

BUY IT NOW!

Click Here To Order

PayPal Discover MasterCard VISA

152-13 COMPONENT LOCATION

1995 BRONCO

Connector	Location	Page Zone	Connector		
			Page	Color	Terminal
C330	Mounted near RH side of cowl panel, to right crash sensor	151-1 F3			4
C402	Under driver, on LH frame rail	151-6 E1			3
C404	On rear axle	151-6 A7			2
C405	Under LH rear of vehicle, on frame rail, near fuel tank	151-7 D10		GY	4
C406	Under LH rear of vehicle, near rear crossmember	151-7 F7		GY	4
C407	Under center rear of vehicle, near rear crossmember	151-7 E10			4
C417	Under vehicle, near rear crossmember	151-7 D10			7
C418	Under LH rear of vehicle, near rear lamp assembly	151-7 F7		N	4
C424	Under center rear of vehicle, near rear crossmember	151-7 D10		GY	4
C428	In LH side of tailgate, on tailgate latch switch	151-6 E10		BK	2
C429	In lower center of tailgate, to tailgate power window motor	151-6 D10		GY	2
C431	LH rear of vehicle, on left rear park/stop/turn lamp	151-7 F8		BK	3
C432	RH rear of vehicle, on right rear park/stop/turn lamp	151-7 C10		BK	3
C433	LH rear of vehicle, on left backup lamp	151-7 F6		BK	2
C434	RH rear of vehicle, on right backup lamp	151-7 D10		BK	2
C435	Center rear of vehicle, on license lamp	151-7 E10		BK	2
C436	Center rear of vehicle, on license lamp	151-7 E10		BK	2
C441	Top RH side of fuel tank, on fuel pump module	151-6 C10		BK	4
C500	In lower front LH front door, to left front window motor	151-7 B1		GY	2
C502	In rear of LH front door, on left door lock motor	151-7 D1		N	2
C503	In center of LH door, on window/door lock control switch (Master/Left)	151-7 C1	100-3		15
C504	In lower rear of LH door, on left door courtesy lamp	151-7 D1		BK	2
C507	In top front of LH door, on left door speaker	151-7 A1		GY	2
C508	In front of LH door, to left power mirror	151-6 C1			4
C509	Behind RH cowl panel	151-6 A5	124-2	GY	8
C510	In LH door, at disarm switch	151-6 C1		N	2
C511	In center of LH door, near power mirror switch	151-6 C1	124-2	GY	8
C512	In lower front of RH door, to right front window motor	151-7 F5		N	2
C513	In rear of RH door, on right door lock motor	151-7 A10		N	2

100% SATISFACTION GUARANTEED

BUY IT NOW!

Click Here To Order

* |

COMPONENT LOCATION 152-14

1995 BRONCO

<u>Connector</u>	<u>Location</u>	<u>Page Zone</u>	<u>Connector Page</u>	<u>Color</u>	<u>Terminal</u>
C603	In center of RH door, on right window and right door lock control switch	151-7 A7	100-3		10
C606	In lower rear of RH door, on right door speaker	151-7 A8		BK	2
C607	In top front of RH door, on right door speaker	151-7 A6		GY	2
C608	In front of RH door, to right power mirror	151-6 A6		N	2
C609	In RH door, at disarm switch			N	2
C905	Center of roof, on map lamps	151-7 A5		GY	1
C906	Center of roof, on dome lamp	151-7 A5		GY	1
C907	Top center rear of vehicle, on outside cargo/high-mount stop lamp	151-7 B10		GY	3
C908	Center of rear window header, near inside cargo lamp	151-7 B10		GY	3
C911	In driver's side visor, on left vanity mirror lamp	151-6 A3			1
C912	In passenger's side visor, on right vanity mirror lamp	151-6 A5			1
C913	In center of windshield header, on day/night mirror/autolamp sensor	151-7 A4			3
C914	In center of windshield header, on overhead console	151-7 A4	102-2		10
C1003	RH side of engine compartment, behind battery	151-1 E1		N	4
C1005	Front RH side of lower radiator support, on low pitch horn	151-2 F3		BK	1
C1006	Front RH side of lower radiator support, on high pitch horn	151-2 F2		BK	1
C1007	Top RH front of engine, on idle air control valve	151-1 F6		BK	2
C1008	LH rear of engine, on ignition coil	151-1 A7			3
C1009 (5.0L)	Center rear of engine, on knock sensor	151-1 A4		BK	2
C1011	Top RH side of safety wall, on manifold absolute pressure (MAP) sensor	151-1 A3		BK	3
C1012	Below center of vehicle, LH side of transmission, on transmission range (TR) sensor	151-6 F2	93-3	BK	8
C1017	LH side of engine, near radio capacitor	151-1 A8			
C1019 SPOUT Check Connector	LH rear of engine compartment, taped to harness, near ignition control module (ICM)	151-1 C10		BK	2
	LH rear of transmission, on output shaft speed sensor	151-6 F3			2

100% SATISFACTION GUARANTEED

BUY IT NOW!

Click Here To Order

153-1 HARNESS CAUSAL PART NUMBER

1995 BRONCO

HOW TO IDENTIFY A BASIC HARNESS NUMBER BY USING A "C" NUMBER

Understand these symbols before using the following listing:

HARNESS TO HARNESS CONNECTION

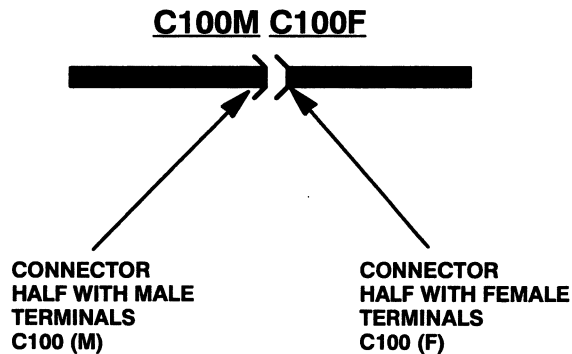

DASHED LINES INDICATE TERMINALS OF SAME CONNECTOR

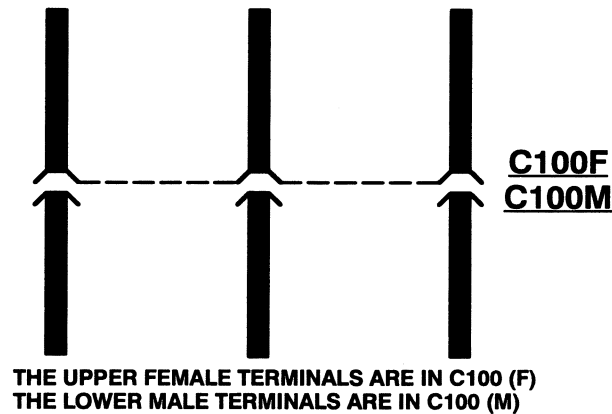

COMPONENT CONNECTION

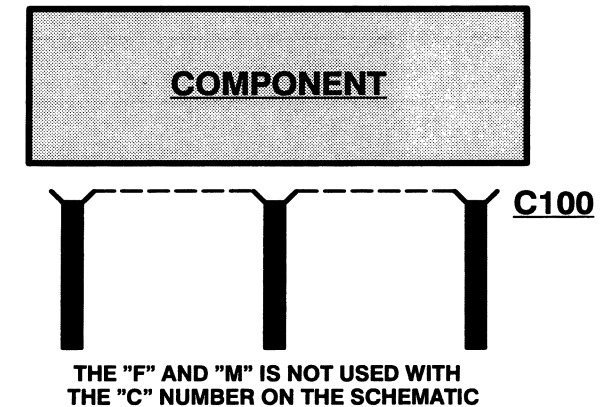

Identify the basic harness part number by:

1. Find the connector "C" number in the EVTm schematics. Then locate the "C" number in the following listing and

2. If you find a problem (such as a short or a broken wire), then choose a connector located on the same harness that has the problem. Use the following listing and read the base part number of the harness that has the problem.

100% SATISFACTION GUARANTEED

BUY IT NOW!

Click Here To Order

PayPal American Express Discover MasterCard VISA

HARNES CAUSAL PART NUMBER

153-2

1995 BRONCO

<u>Connector</u> <u>Number</u>	<u>Wire</u> <u>Assembly</u>	<u>Connector</u> <u>Number</u>	<u>Wire</u> <u>Assembly</u>	<u>Connector</u> <u>Number</u>	<u>Wire</u> <u>Assembly</u>	<u>Connector</u> <u>Number</u>	<u>Wire</u> <u>Assembly</u>
C101 (F)	9D930	C169	18A586	C209 (F)	14B095	C250	14401
C101 (M)	12A581	C170	12A581	C209 (M)	14401	C251	14401
C102	12A581	C171	9D930	C210 (F)	14A348	C252	14401
C103 (F)	15525	C173 (F)	15A702	C210 (M)	14401	C257	14401
C103 (M)	12A581	C173 (M)	12A581	C211	19B113	C258	14401
C106 (F)	12A581	C177	12A581	C212	19B113	C260	14401
C106 (M)	18A586	C178	9D930	C213 (F)	14A285	C261	14401
C107 (M)	12A581	C180	9D930	C213 (M)	14A509	C262	14401
C107 (F)	12A690	C182	9D930	C214 (M)	14A504	C263	14A504
C110 (F)	15525	C183	9D930	C214 (F)	14A509	C267	14401
C110 (M)	12A581	C185	12A581	C215 (F)	14A509	C269	14401
C116	*	C190	9D930	C215 (M)	14A504	C271	14401
C117 (F)	14K067	C190	PIA	C217	14401	C273	14401
C117 (M)	15525	C191	9D930	C218	14401	C274	14401
C119	12A581	C191	PIA	C219	14401	C275	14401
C120	12A581	C192	9D930	C220	14B095	C276	14401
C121	12A581	C192	PIA	C221	14B095	C278	14401
C122	12A581	C193	9D930	C222	14B095	C279	14401
C123	12A581	C193	PIA	C223	14B095	C280	14401
C124	12A581	C194	9D930	C224	14401	C282	AUDIO CABLE
C126	9D930	C194	PIA	C225	14401	C283	19B113
C127	15525	C195	9D930	C225	14401	C292	14401
C128	12A581	C195	PIA	C226	14401	C293	13A726
C129	12A581	C196	9D930	C227	PIA	C294	13A726
C130	12A581	C196	PIA	C228 (F)	14630	C295	13A726
C131	12A581	C197	9D930	C228 (M)	14401	C296	14401
C135	9D930	C197	PIA	C229 (F)	14A504	C298	14401
C139 (F)	14305	C198	12A581	C229 (M)	14401	C299 (F)	17K745
C139 (M)	12A581	C199	12A581	C230	14401	C299 (M)	14A504
C151	12A581	C200 (F)	14A504	C231	14401	C300 (F)	14334
C152	12A581	C200 (M)	14401	C232	14401	C300 (M)	14A504
C153	14305	C202 (F)	14401	C234	13A726	C302	14A504
	14305	C202 (M)	12A581	C236	14401	C305	14B084
		C203 (F)	18A586	C237	14401	C306	14B084
		C203 (M)	14401	C238	14401	C310	14086
		C204 (F)	14401	C240	14401	C311	14086
		C204 (M)	13A726	C241	14401	C312	14B084
		C205 (F)	14401	C242	14401	C313 (F)	14A504
		C205 (M)	14405	C243	14401		
		C207	14401	C244	14401		

* NO FIGURE AVAILABLE

100% GUARANTEED

BUY IT NOW!

Click Here To Order

PayPal American Express Discover MasterCard VISA

153-3

HARNES CAUSAL PART NUMBER

1995 BRONCO

<u>Connector</u> <u>Number</u>	<u>Wire</u> <u>Assembly</u>	<u>Connector</u> <u>Number</u>	<u>Wire</u> <u>Assembly</u>	<u>Connector</u> <u>Number</u>	<u>Wire</u> <u>Assembly</u>
C313 (M)	14B084	C504	14A509	C1028	15525
C314 (F)	14A504	C507	14A509	C1030	12A581
C314 (M)	14B084	C508	14A509	C1031	12A581
C315 (F)	14335	C509 (F)	14A265	C1032	12A581
C315 (M)	14A504	C509 (M)	14A509	C1033	12A581
C317	14B084	C510	14A509	C1034	12A581
C318 (F)	13A625	C550	14A509	C1035	15A702
C318 (M)	14335	C600	14630	C1040	PIA
C326	14A504	C602	14630	C1048	15525
C327	14A504	C603	14630	C1049	15525
C328	14B095	C606	14630	C1052	12A581
C329	14401	C607	14630	C1053	12A581
C330	12A581	C608	14630	C1054	12A581
C402	14405	C609	14630	C1055	12A581
C404	14405	C905	14334	C1056	PIA
C405 (F)	14405	C906	14334	C1069	12A690
C405 (M)	13A409	C907	13A625		
C406 (F)	14405	C908	13A625		
C406 (M)	13A409	C910	14334		
C407 (F)	13A576	C911	17K745		
C407 (M)	14405	C912	17K745		
C417	13A576	C913	17K745		
C418 (F)	14405	C914	17K745		
C418 (M)	14086	C1003 (F)	12A690		
C424 (F)	13A576	C1003 (M)	12A581		
C424 (M)	14405	C1005	12A581		
C428	14086	C1006	12A581		
C429	14086	C1007	9D930		
C431	13A409	C1008	9D930		
C432	13A409	C1009	9D930		
C	13A409	C1011	12A581		
C	13A409	C1012	15525		
C	13A409	C1017	9D930		
C	13A409	C1019	12A581		
C	13A409	C1020	15525		
C	13A409	C1024	9D930		
C	13A409	C1025	12A690		
C	13A409	C1026	9D930		



BUY IT NOW!

Click Here To Order





100% SATISFACTION GUARANTEED

BUY IT NOW!

Click Here To Order

PayPal American Express Discover MasterCard VISA

160-1 VEHICLE REPAIR LOCATION CODES

1995 BRONCO

VEHICLE REPAIR LOCATION CODES

TO PINPOINT THE ACTUAL VEHICLE LOCATION OF A REPAIR, THE VEHICLE REPAIR LOCATION CODE IS REQUIRED.

FOR EXAMPLE, AN "X" HAS BEEN PLACED IN THE QUADRANT OF THE VEHICLE DIAGRAMS INDICATING THE LOCATION OF THE REPAIR. SEE DIAGRAMS.

LOCATION CODE, FOR THE EXAMPLE IS: A5/FU — (UNDER THE FLOOR OF DRIVER'S LEFT FOOT.)

FRONT/REAR DIRECTION

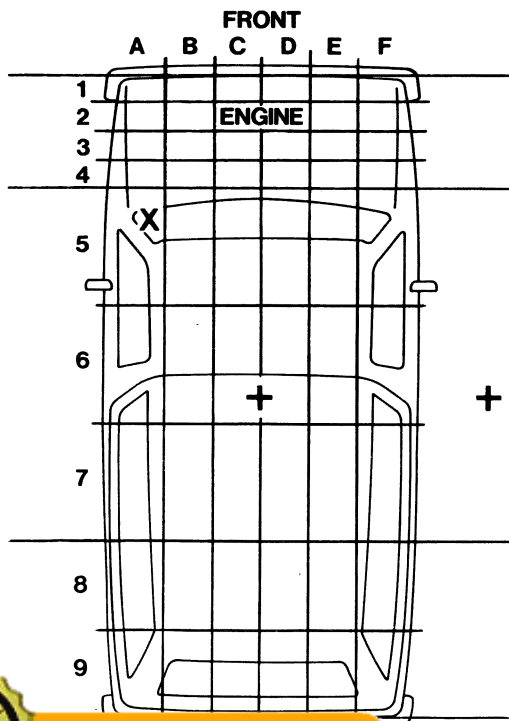

OVER/UNDER DIRECTION

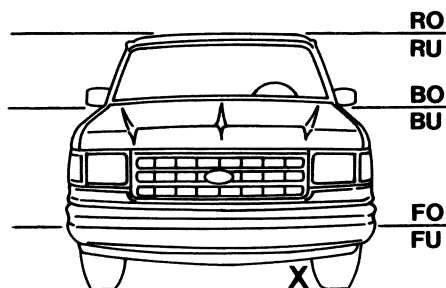

R = ROOF LINE
RO = ROOF OVER
RU = ROOF UNDER
B = BELT LINE
BO = BELT OVER
BU = BELT UNDER
F = FLOOR PAN
FO = FLOOR OVER
FU = FLOOR UNDER

+ CENTER OF VEHICLE

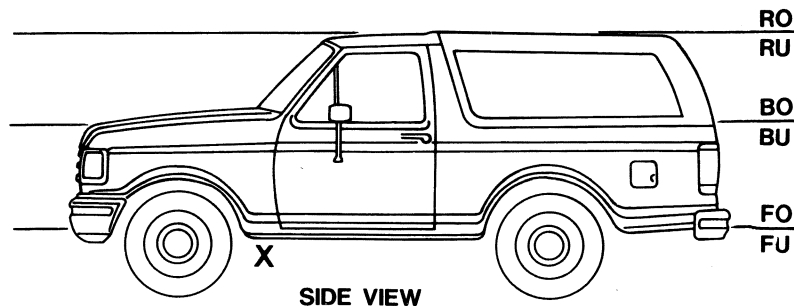

SIDE VIEW

BRONCO

FCS-12129-95



BUY IT NOW!

[Click Here To Order](#)



100% SATISFACTION GUARANTEED

BUY IT NOW!

Click Here To Order 

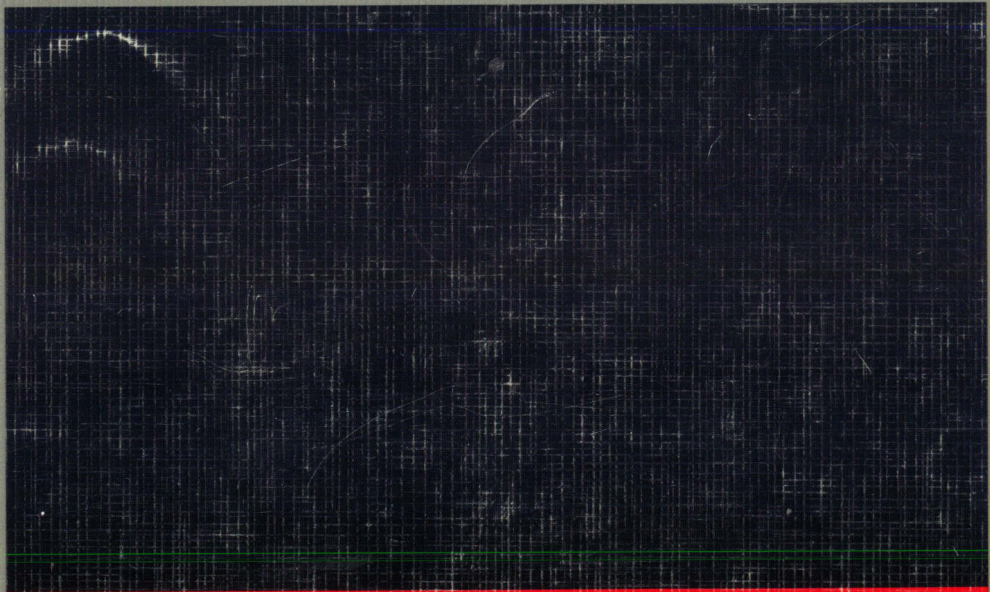

**TECHNICAL
PUBLICATIONS DEPARTMENT**
Ford Customer Service Division



FCS-12129-95

Copyright © 1994
Ford Motor Company