

BUY IT NOW!
Click Here To Order

Logos: American Express, Discover, MasterCard, VISA



Buy Now

Logos: MasterCard, VISA, American Express, Discover, BANK

MUSTANG

DEMO

This DEMO contains only a few pages of the entire manual/product.

Not all Bookmarks work on the Demo, but they do on the full version.

Features:

- Searchable text
- Printable pages
- Bookmarked for easy navigation
- High Resolution images
- Zoom to see exact details
- Money back Guarantee
- Available on USB and eBook download

1 9 9 4

ELECTRICAL AND VACUUM TROUBLESHOOTING MANUAL



License #84356800

Copyright © 2024, Forel Publishing Company, LLC, Woodbridge, Virginia

All Rights Reserved. No part of this book may be used or reproduced in any manner whatsoever without written permission of Forel Publishing Company, LLC. For information write to Forel Publishing Company, LLC, Woodbridge, VA 22192

**1994 Mustang Electrical and Vacuum
Trouble-Shooting Manual (EVTM)
EAN: 978-1-60371-429-7
ISBN: 1-60371-429-4**

Forel Publishing Company, LLC
Woodbridge, VA 22192
Email: sales@ForelPublishing.com
<https://www.ForelPublishing.com>



License #84356800

This publication contains material that is reproduced and distributed under a license from Ford Motor Company. No further reproduction or distribution of the Ford Motor Company material is allowed without the express written permission of Ford Motor Company.

Note from the Publisher

This product was created from the original Ford Motor Company's publication. Every effort has been made to use the original scanned images, however, due to the condition of the material; some pages have been modified to remove imperfections.

Disclaimer

Although every effort was made to ensure the accuracy of this book, no representations or warranties of any kind are made concerning the accuracy, completeness or suitability of the information, either expressed or implied. As a result, the information contained within this book should be used as general information only. The author and Forel Publishing Company, LLC shall have neither liability nor responsibility to any person or entity with respect to any loss or damage caused, or alleged to be caused, directly or indirectly by the information contained in this book. Further, the publisher and author are not engaged in rendering legal or other professional services. If legal, mechanical, electrical, or other expert assistance is required, the professional should be sought.



We Want To Hear From You!

Your suggestions will help us to improve this manual.

Mail this form or fax your comments to:

(313) 390-8727

Manual _____ Vehicle _____ Year _____

Did you find any errors in the procedures or illustrations?

YES	NO
<input type="checkbox"/>	<input type="checkbox"/>

If yes, page _____ please describe in detail: _____

Did the procedures make sense and were they easy to follow?

YES	NO
<input type="checkbox"/>	<input type="checkbox"/>

If no, page _____ please describe: _____

Is the organization of the manual clear and easy to follow?

YES	NO
<input type="checkbox"/>	<input type="checkbox"/>

Please comment: _____

Are there any important procedures not covered in this manual that you would like to see included?

YES	NO
<input type="checkbox"/>	<input type="checkbox"/>

If yes, please describe: _____

Please enclose a copy of each page marked with your suggestions.

Please tell us who you are:

Name _____

Street _____

State _____ Zip _____



BUY IT NOW!

Click Here To Order



DO NOT STAPLE — USE TRANSPARENT TAPE



NO POSTAGE
NECESSARY
IF MAILED
IN THE
UNITED STATES

BUSINESS REPLY MAIL

FIRST CLASS

PERMIT NO. 400

DEARBORN, MI

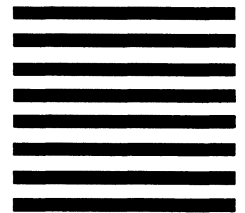

POSTAGE WILL BE PAID BY ADDRESSEE

**Technical Service Publications
EVTM
P.O. Box 2592
Dearborn, MI 48121-9973**



BUY IT NOW!
Click Here To Order

ELECTRICAL AND VACUUM TROUBLESHOOTING MANUAL FPS-12121-94

FORD PARTS and SERVICE DIVISION

Quality is Job 1

Ford Parts and Service Division has developed a new format for the 1994 Mustang. EVTVM. Our goal is to provide accurate and timely electrical and vacuum service information.

1994 EVTVM FEATURES

- **Schematic pages** now contain **COMPONENT LOCATION** references to full-view illustrations and description notes have been added to various components to describe their operation.
- **"COMPONENT TESTING"** procedures (CELL 149) that tell the user how to perform diagnostic tests on various circuits.
- **Component Connector End Views** are located at the end of individual cells and are shown for connectors with five or more cavities; for connectors with ten or more cavities, a circuit function chart is provided.
- Both halves of the In-line connectors (CELL 150) with 10 cavities or more are shown and have pin numbers assigned.
- **NOTES, CAUTIONS and WARNINGS** that contain important safety information.
- Full view **"COMPONENT LOCATION VIEWS"** (CELL 151) to help locate on-vehicle components.
- Circuit voltages on schematic pages help simplify troubleshooting.
- **Cellular Pagnation:** A specific section (or cell) in all EVTVMs is numbered by cell and starts with page 1. For example: **"HOW TO USE THIS MANUAL"** is CELL 2 and begins with page 2-1.

"C" numbers are used for all electrical connectors. "C" numbers are listed in numerical order in the **"LOCATION INDEX"** (CELL 152).

add to aid in identifying warranty concerns (CELL 153).

ORDERING INFORMATION

Information about how to order additional copies of this publication or other Ford publications may be obtained by writing to Helm Incorporated at the address shown below or by calling 1-800-782-4356. Other publications available include:

- Service Manuals
- Service Specification Books
- Car/Truck Wiring Diagrams
- Powertrain Control/Emissions Diagnosis Manuals

Helm Incorporated
P.O. Box 07150
Detroit, Michigan 48207



1-1 TABLE OF CONTENTS/INDEX

1994 MUSTANG

Table of Contents

How to Use This Manual	2-1
Grounds	10-1
Circuit Protection/Fuse Panel	11-1
Charging System	12-1
Power Distribution	13-1
Starting System	20-1
Ignition System	21-1
Electronic Engine Control (3.8L)	23-1
Electronic Engine Control (5.0L)	24-1
Electronic Automatic (AODE)	
Transmission	29-1
Speed Control	31-1
Shift Lock	37-1
Horn/Cigar Lighter/Clock	44-1
Anti-Lock Brake System (ABS)	42-1
Air Bag Restraint System	46-1
Heater	53-1
Air Conditioner/Heater	54-1
Rear Window Defrost	56-1
Instrument Cluster	60-1
Vehicle Speed Sensor (VSS)	64-1
Warning Chime	66-1
Instrument Illumination	71-1
Interval Wiper/Washer	81-1
Headlamps	85-1
Fog Lamps	86-1
Courtesy Lamps	89-1
Turn/Stop/Hazard Lamps	90-1
Exterior Lamps	92-1
Backup Lamps	93-1
Illuminated Entry	94-1
Daytime Running Lamps	97-1
Power Windows	100-1
Convertible Top	102-1
Control Switch	110-1
Right Window/Door Lock Control	111-1
Switch	112-1
Multi-Function Switch	113-1
Convertible Top	110-1

Power Lumbar Seats	122-1
Power Mirrors	124-1
Radio	130-1
Vacuum Distribution	142-1
Component Testing	149-1
In-Line Connector Faces	150-1
Component Location Views	151-1
Location Index	152-1
Harness Causal Part Numbers	153-1
Vehicle Repair Location Codes	160-1

Index

Air Bag Restraint System	46-1
Air Conditioner/Heater	
Vacuum	54-1
Electrical	54-2
Anti-Lock Brake System	42-1
Anti-Theft	112-1
Backup Lamps	93-1
Charging System	12-1
Cigar Lighter	44-1
Circuit Protection/Fuse Panel	11-1
Clock	44-1
Component Location Views	151-1
Component Testing	
A/C-Heater Control Assembly	149-6
Blower Motor Switch	149-7
Heater Control Assembly	149-5
Ignition Switch	149-2
Introduction	149-1
Main Light Switch	149-1
Manual Lever Position (MLP)	
Sensor	149-8
Master Window/Door Lock	
Control Switch	149-9, 149-10, 149-11, 149-12
Right Window/Door Lock Control	
Switch	149-13
Multi-Function Switch	149-3, 149-4
Convertible Top	102-1

Courtesy Lamps	89-1
Daytime Running Lamps (DRL)	97-1
Defrost (Rear Window)	56-1
Door Locks (Power)	110-1
Electronic Automatic (AODE)	
Transmission	29-1
Electronic Engine Control	
3.8L	23-1
5.0L	24-1
Engine Compartment Fuse Box	
ABS	13-3
ALT	13-4
AUDIO	13-4
CIG ILLUM	13-3
CONV TOP	13-3
DRL, FOG, HORNS	13-4
EEC	13-2
FAN	13-1
FUEL PUMP	13-1
HD LPS	13-2
HTD BL	13-1
IGN SW	13-2
IGN SW	13-2
IGN SW	13-2
INT LPS	13-4
L. SPD EDF MNTR	13-4
Exterior Lamps	92-1
Fog Lamps	86-1
Gauges	
Fuel	60-1
Oil Pressure	60-2
Speedometer	60-2
Tachometer	60-3
Temperature	60-1
Voltmeter	60-2
Grounds	
G102	10-1
G103	10-1
G104	
3.8L	10-2

100% SATISFACTION GUARANTEED

BUY IT NOW!

Click Here To Order

PayPal Discover MasterCard VISA

TABLE OF CONTENTS/INDEX 1-2

1994 MUSTANG

5.0L	10-3	Fuse 4	13-7	Instrument Illumination	71-1
G105		Fuse 5	13-6	Luggage Compartment	89-1
3.8L	10-2	Fuse 6	13-5	Map	89-4, 89-5
5.0L	10-3	Fuse 7	13-5	Vanity Mirror	89-4, 89-5
G201	10-3	Fuse 8	13-7	Location Index	152-1
G203	10-4	Fuse 9	13-6	Main Light Switch	13-12
G204	10-6	Fuse 10	13-6	Mirrors (Power)	124-1
G300	10-9	Fuse 11	13-5	Power Distribution	13-1
Harness Causal Part Numbers	153-1	Circuit Breaker 12	13-7	Power Door Locks	
Headlamps	85-1	Fuse 13	13-12	Convertible	110-2
Heater	53-1	Circuit Breaker 14	13-5	Coupe	110-1
Horn	44-1	Fuse 15	13-5	Power Lumbar Seats	122-1
Ignition Switch	13-5, 13-6	Fuse 16	13-8	Power Seats	120-1
Ignition System		Fuse 17	13-5	Power Mirrors	124-1
3.8L	21-1	Fuse 18	13-5	Power Windows	100-1
5.0L	21-3	Lamps (Exterior)		Radio	
Illuminated Entry	94-1	Backup	93-1	AM/FM Stereo	130-1
Indicators		Daytime Running	97-1	Premium Sound	
Air Bag	60-4	Fog	86-1	(w/out CD Player)	130-2
Anti-Lock	60-4	Exterior	92-1	Premium Sound	
Anti-theft	60-2	Hazard	90-1	(w/ CD Player)	130-3
Brake	60-4	Headlamps	85-1	SuperSound	
Charge	60-2	License	92-1	(w/out CD Player)	130-5
"Low Oil"	60-3	Park		SuperSound	
Fasten Belts	60-5	Front	92-1	(w/ CD Player)	130-6
Hi Beam	60-5	Rear	92-1	Remote/Keyless Entry	111-1
Left Turn	60-5	Side Marker		Rear Window Defrost	56-1
Low Coolant	60-4	Front	92-1	Seats (Lumbar)	122-1
Malfunction Indicator Lamp (MIL)		Rear	92-1	Seats (Power)	120-1
(Check Engine)	60-1	Stop	90-3	Shift Lock	37-1
Right Turn	60-5	Stop (Hi Mount)	90-1	Speed Control	31-1
Transmission Control Indicator Lamp		Turn		Starting System	20-1
(TCIL) (OD OFF)	60-1	Front	90-2	Trunk Lid Release	113-1
In-Line Connector Faces	150-1	Rear	90-3	Turn/Stop/Hazard Lamps	90-1
Instrument Cluster	60-1	Lamps (Interior)		Vacuum Distribution	142-1
.....	71-1	Courtesy	89-1	Vehicle Repair Location Codes	160-1
.....	81-1	Dome	89-4, 89-5	Vehicle Speed Sensor (VSS)	64-1
.....	13-6	Engine Compartment	89-4, 89-5	Warning Chime	66-1
.....	13-5	Glove Compartment	89-4, 89-5		

100% SATISFACTION GUARANTEED

BUY IT NOW!

Click Here To Order

1-3 TABLE OF CONTENTS/INDEX

1994 MUSTANG

Windows (Power) 100-1
Wiper/Washer (Interval) 81-1

IMPORTANT SAFETY NOTICE

Appropriate service methods and proper repair procedures are essential for the safe, reliable operation of all motor vehicles, as well as the personal safety of the individual doing the work. This Manual provides general directions for accomplishing service and repair work with tested, effective techniques. Following them will help assure reliability.

There are numerous variations in procedures, techniques, tools, and parts for servicing vehicles, as well as in the skill of the individual doing the work. This Manual cannot possibly anticipate all such variations and provide advice or cautions as to each. Accordingly, anyone who departs from the instructions provided in this Manual must first establish that he compromises neither his personal safety nor the vehicle integrity by his choice of methods, tools or parts.



BUY IT NOW!
Click Here To Order



NOTES 1-4

1994 MUSTANG

**SATISFACTION
100%
GUARANTEED**

BUY IT NOW!
Click Here To Order

PayPal American Express Discover MasterCard VISA

2-1 HOW TO USE THIS MANUAL

1994 MUSTANG

The purpose of this manual is to show electrical and vacuum circuits in a clear and simple fashion to make troubleshooting easier. **NOTES**, **CAUTIONS** and **WARNINGS** contain important information.

- **NOTES** describe how switches and other components operate to help complete a particular procedure.
- **CAUTIONS** provide information that could prevent making an error that may damage the vehicle.
- **WARNINGS** provide information to prevent personal injury.

The **WARNINGS** list on page 2-2 contains general warnings to follow when servicing a vehicle.

Components that work together are shown together. All electrical components used in a specific system are shown on one diagram. The circuit breaker or fuse is shown at the top of the page. All wires, connectors, components and splices are shown in the flow of current to ground at the bottom of the page. If a component is used in several different systems, it is shown in several places. For example, the Main Light Switch is electrically a part of many systems and is repeated on many pages.

In some cases, a component may seem (by its name) to belong to a system where it has no electrical connection. For example, Radio Illumination is electrically part of Instrument Illumination, but because it has no electrical connection to the Radio system, it is not shown on

text blocks located next to each component and connector and refer the user to the appropriate illustration page and zone. The description notes describe the operation of the component.

Schematic pages contain circuit voltages to help simplify troubleshooting hints. 12V is used to imply battery voltage on a component connector terminal, and 0V is used to show that there should be continuity to ground on that particular terminal. Conditional voltages such as "12V with the ignition switch in RUN" will also be provided. Troubleshooting hints that can't be simplified with circuit voltages will be shown at the end of each cell.

Component connector face information specific to a certain cell is found at the end of that cell. A Connector Face Reference List is provided to locate connector faces that are shown in different cells. Component connectors with five or more terminals are illustrated. Component Connectors with 10 or more terminals are accompanied by a pinout chart that lists the function of all circuitry associated with that component.

"GROUNDS" (Cell 10) contains ground circuitry shown in complete detail. This information is useful for checking interconnections of the ground circuits of different systems.

"POWER DISTRIBUTION" (Cell 13) contains power distribution circuitry shown in complete detail. This section displays how the various fuses are powered and, in turn, how each system is powered.

"COMPONENT TESTING" (Cell 149) contains testing procedures for various switches. This information includes schematics, component terminal locations and step-by-step procedures.

"IN-LINE CONNECTOR FACES" (Cell 150) contains illustrations of all the in-line connectors that have 10 or more terminals. The terminals have pin numbers assigned to them.

"COMPONENT LOCATION VIEWS" (Cell 151) contains full-view illustrations which show the location of all components and connectors in the vehicle.

The **"LOCATION INDEX"** (Cell 152) provides the base part numbers, locations, connector face references and illustration references for all components, connectors, splices and grounds.

HELPFUL REMINDERS

Before using the EVTM for troubleshooting, refer to these HELPFUL REMINDERS:

1. The abbreviation T/O, for take out, used in the Location Index (Cell 152), refers to the point at which a group of wires branch off the harness trunk. Refer to the wiring harness illustration.

to full-
r vari-
erse-

HOW TO USE THIS MANUAL 2-2

1994 MUSTANG

Wiring harness at back of Instrument Panel, showing typical T/O (Take Out) locations

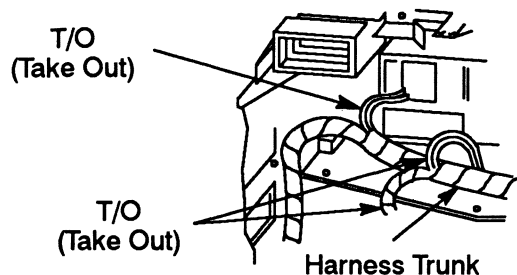

COLOR ABBREVIATIONS

BL	Blue	N	Natural
BK	Black	O	Orange
BR	Brown	PK	Pink
DB	Dark Blue	P	Purple
DG	Dark Green	R	Red
GN	Green	T	Tan
GY	Gray	W	White
LB	Light Blue	Y	Yellow
LG	Light Green		

Note: Whenever a wire is labeled with two colors, the first color listed is the basic color of the wire, and the second color listed is the stripe marking of the wire.

- If a connector serves the same purpose in two separate versions (e.g., EFI/Carb), but is physically different, two connector numbers are used. However, if a connector serves the same purpose in two separate versions (e.g., EFI/Carb) and is physically the same, but the wire colors are different, only one connector number is used. If the same physical connector is used more than once, then more than one connector number is used.
- Wiring schematics provide a picture of how and under what conditions the circuit is powered, of the current path to circuit components, and of how a circuit is grounded. Each circuit component is named (underlined titles). Wire and connector colors are listed (standard Ford color abbreviations are used):

- When reporting Vehicle Repair Location Codes to Ford Parts and Service Division, refer to Cell 160 (beginning on page 160-1). Note: Do *not* use the illustrations in Cell 151 (beginning on page 151-1) for reporting Vehicle Repair Location Codes.

5. WARNINGS

- Always wear safety glasses for eye protection.
- Use safety stands whenever a procedure requires being under a vehicle.
- Be sure that the Ignition Switch is always in the OFF position, unless otherwise required by the procedure.
- Set the park brake when working on any vehicle. An automatic transmission should be in PARK. A manual transmission should be in NEUTRAL.
- Operate the engine only in a well-ventilated area to avoid danger of carbon monoxide.

- Keep away from moving parts, especially the fan and belts, when the engine is running.
- To prevent serious burns, avoid contact with hot metal parts such as the radiator, exhaust manifold, tail pipe, catalytic converter and muffler.
- Do not allow flame or sparks near the battery. Gases are always present in and around the battery cell. An explosion could occur.
- Do not smoke.
- To avoid injury, always remove rings, watches, loose hanging jewelry and loose clothing.

HOW TO FIND ELECTRICAL CONCERNS

TROUBLESHOOTING STEPS

These six steps present an orderly method of troubleshooting.

Step 1. Verify the concern.

- Operate the complete system to check the accuracy and completeness of the customer's complaint.

Step 2. Narrow the concern.

- Using the EVTM, narrow down the possible causes and locations of the concern to pinpoint the exact cause.
- Read the description notes at the components and study the wiring schematic. You should then know enough about the circuit operation to determine where to check for the trouble. Further information can be found by referring to the Service Manual pages listed in the box at the top of the page.

100% SATISFACTION GUARANTEED

BUY IT NOW!

Click Here To Order

PayPal American Express Cards DISCOVER NOVUS MasterCard VISA

2-3 HOW TO USE THIS MANUAL

1994 MUSTANG

Step 3. Test the cause.

- Use electrical test procedures to find the specific cause of the symptoms.
- The component location reference bars and the pictures will help you find components. The Location Index (at the end of the manual) gives component location information for connectors, diodes, resistors, splices and grounds.

Step 4. Verify the cause.

- Confirm that you have found the correct cause by connecting jumper wires and/or temporarily installing a known good component and operating the circuit.

Step 5. Make the repair.

- Repair or replace the inoperative component.

Step 6. Verify the repair.

- Operate the system as in Step 1 and check that your repair has removed all symptoms without creating any new symptoms.

Some engine circuits may need special test equipment and special procedures. See the *Service Manual* and other service books for details. You will find the circuits in this manual to be helpful with those special test procedures.

TROUBLESHOOTING TOOLS

JUMPER WIRE

This is a test lead used to connect two points of a circuit. A Jumper Wire can bypass an open to complete a circuit.

100% SATISFACTION GUARANTEED

BUY IT NOW!

Click Here To Order

PayPal American Express Cards Discover MasterCard VISA

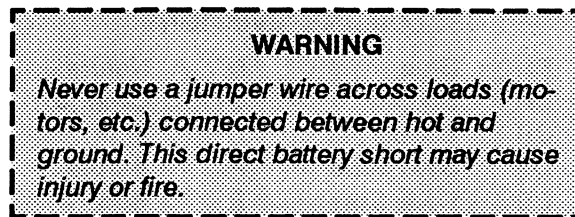

VOLTMETER

A DC Voltmeter measures circuit voltage. Connect negative (- or black) lead to ground, and positive (+ or red) lead to voltage measuring point.

OHMMETER

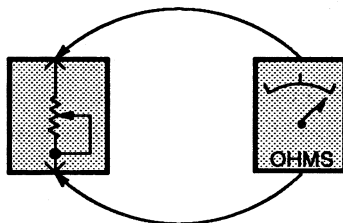

Figure 1—Resistance Check

An Ohmmeter shows the resistance between two connected points (Figure 1).

TEST LAMP

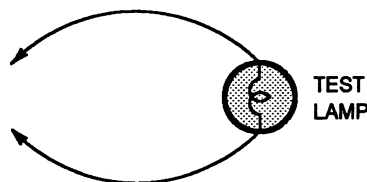

Figure 2—Test Lamp

A Test Light is a 12-volt bulb with two test leads (Figure 2).

Uses: Voltage Check, Short Check.

SELF-POWERED TEST LAMP

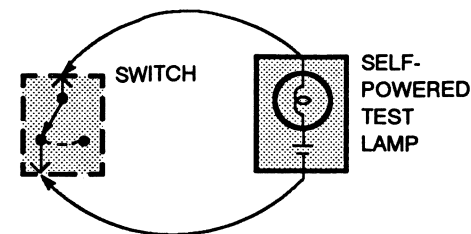

Figure 3—Continuity Check

The Self-Powered Test Lamp is a bulb, battery and set of test leads wired in series (Figure 3). When connected to two points of a continuous circuit, the bulb glows.

Uses: Continuity Check, Ground Check.

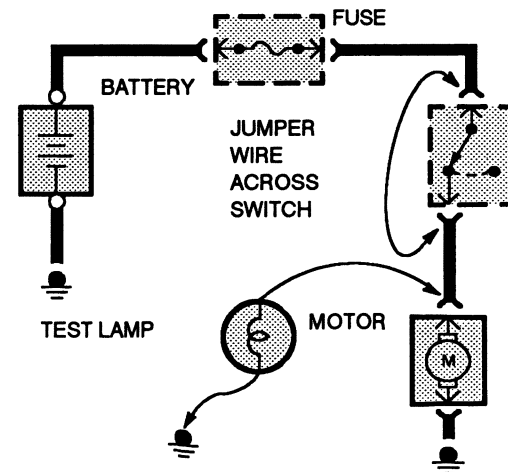
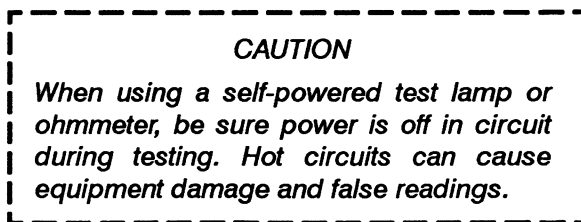

Figure 4—Switch Circuit Check and Voltage Check

In an inoperative circuit with a switch in series with the load, jumper the terminals of the switch to power the load. If jumpering the terminals powers the circuit, the switch is inoperative (Figure 4).

CONTINUITY CHECK (Locating open circuits)

Connect one lead of Self-Powered Test Lamp or Ohmmeter to each end of circuit (Figure 3). Lamp will glow if circuit is closed. Switches and fuses can be checked in the same way.

VOLTAGE CHECK

Connect one lead of test lamp to a known good ground or the negative (-) battery terminal. Test for voltage by touching the other lead to the test point. Bulb goes on when the test point has voltage (Figure 4).

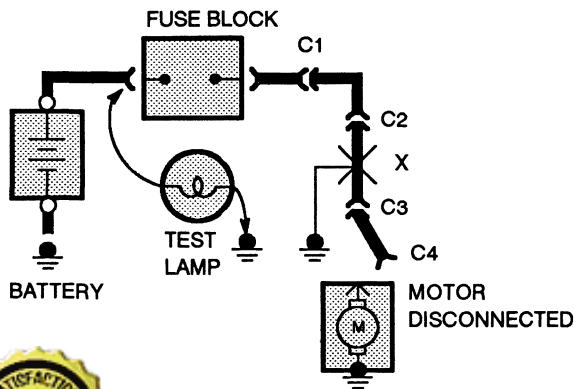

A fuse that repeatedly blows is usually caused by a short to ground. It's important to be able to locate such a short quickly (Figure 5).

1. Turn off everything powered through the fuse.
2. Disconnect other loads powered through the fuse:
 - Motors: disconnect motor connector (Connector C4 in Figure 5).
 - Lights: remove bulbs.
3. Turn Ignition Switch to RUN (if necessary) to power fuse.
4. Connect one Test Lamp lead to hot end of blown fuse. Connect other lead to ground. Bulb should glow, showing power to fuse. *(This step is just a check to be sure you have power to the circuit.)*
5. Disconnect the test lamp lead that is connected to ground, and reconnect it to the load side of the fuse at the connector of the disconnected component. (In Figure 5, connect the test lamp lead to connector C4.)
 - If the Test Lamp is off, the short is in the disconnected component.
 - If the Test Lamp goes on, the short is in the wiring. You must find the short by disconnecting the circuit connectors, one at a time, until the Test Lamp goes out. For example, in Figure 5 with a ground at X, the bulb goes out when C1 or C2 is disconnected, but not after disconnecting C3. This means the short is between C2 and C3.

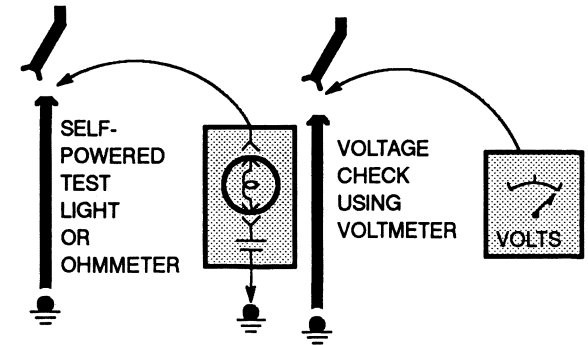

Figure 6—Ground Check

Turn on power to the circuit. Perform a Voltage Check between the suspected inoperative ground and the frame. Any indicated voltage means that the ground is inoperative (Figure 6).

Turn off power to the circuit. Connect one lead of a Self-Powered Test Lamp or Ohmmeter to the wire in question and the other lead to a known ground. If the bulb glows, the circuit ground is OK (Figure 6).

The circuit schematics in this manual make it easy to identify common points in circuits. This knowledge can help narrow the concern to a specific area. For example, if several circuits fail at the same time, check for a common power or ground connection (see *Power Distribution* or *Grounds*). If part of a circuit fails, check the connections between the part that works and the part that doesn't work.

For example, if the lo beam headlamps work, but the high beams and the indicator lamp don't work, then power and ground paths must be good. Since the dimmer switch is the component that switches this power to the high beam lights and indicator, it is most likely the cause of failure.

100% SATISFACTION GUARANTEED

BUY IT NOW!

Click Here To Order

PayPal, American Express, Discover, MasterCard, VISA

2-5 HOW TO USE THIS MANUAL

1994 MUSTANG

TROUBLESHOOTING WIRING HARNESS AND CONNECTOR HIDDEN CONCERNS

The following illustrations are known examples of wiring harness, splices and connectors that will create intermittent electrical concerns. The concerns are hidden and can only be discovered by a physical evaluation as shown in each illustration.

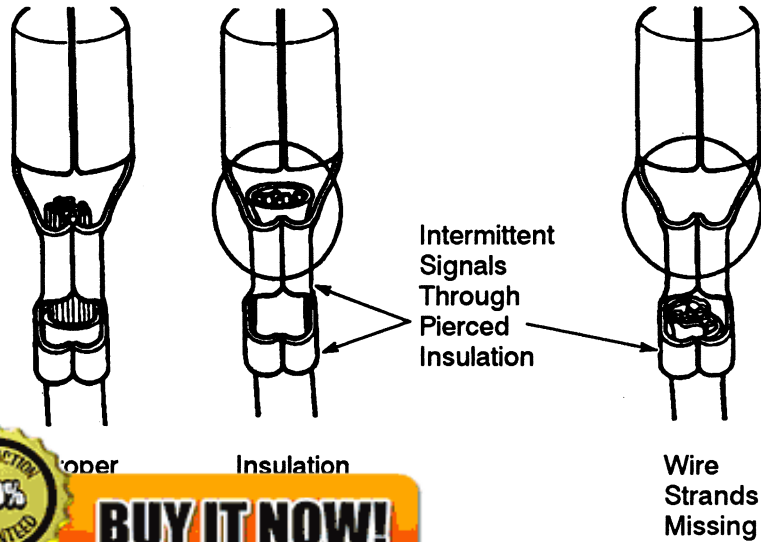

100% SATISFACTION GUARANTEED

BUY IT NOW!

Click Here To Order

WIRE STRIPPING

PayPal, American Express, Discover, MasterCard, VISA

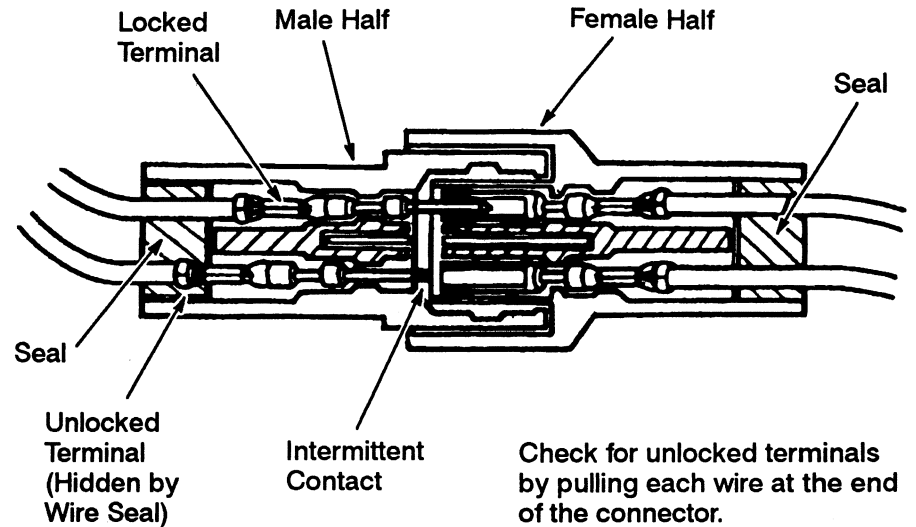

TERMINAL NOT PROPERLY SEATED

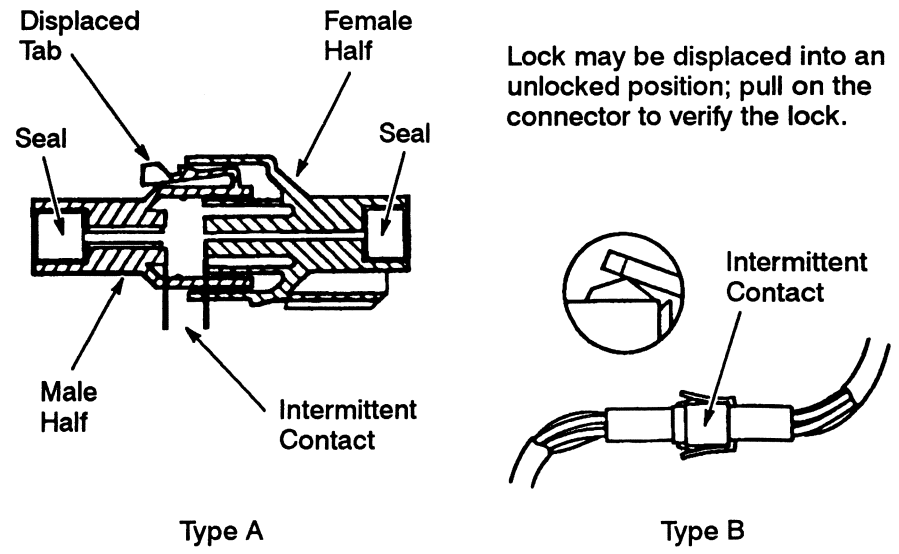

PARTIALLY MATED CONNECTORS

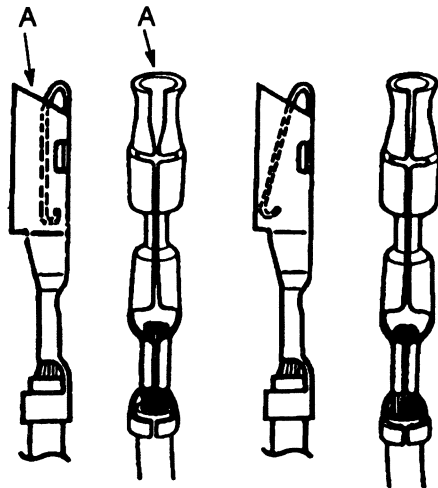

Enlarged

Normal

Any probe entering the terminal may enlarge the contact spring opening creating an intermittent signal. Insert the correct mating terminal (Location A) from the service kit and feel for a loose fit.

DEFORMED (ENLARGED) FEMALE TERMINALS

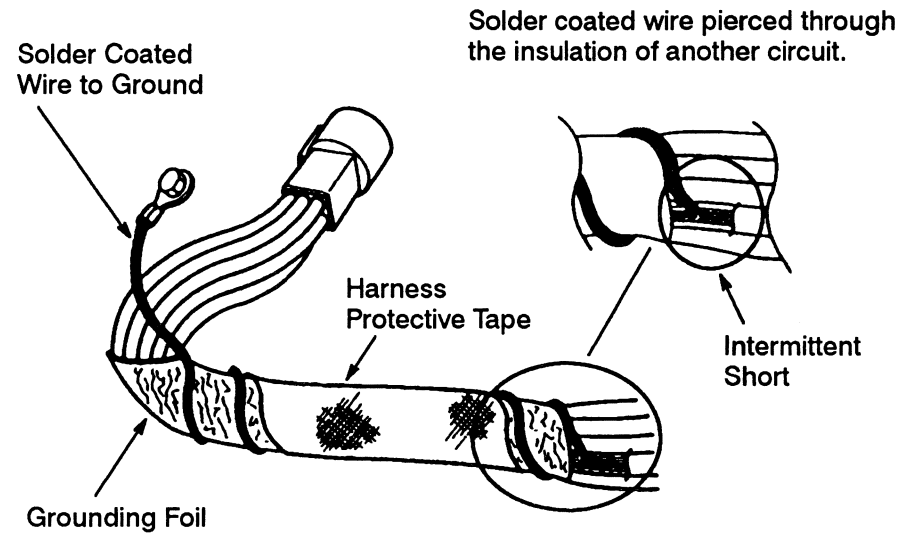

ELECTRICAL SHORT INSIDE THE HARNESS

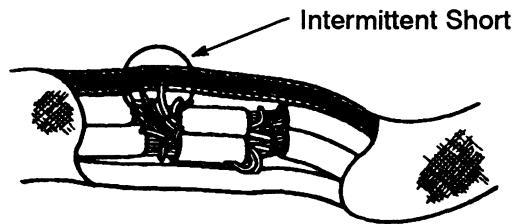

Splice Tape Removed

Operate the system and flex the harness at splice location noted in Section 152.

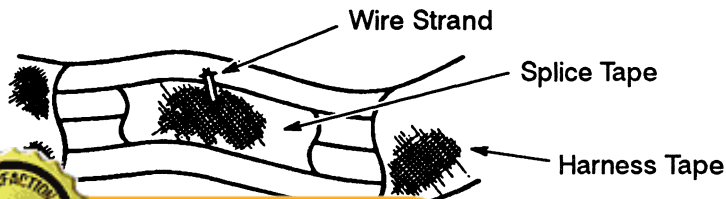

Wire Strand

Splice Tape

Harness Tape

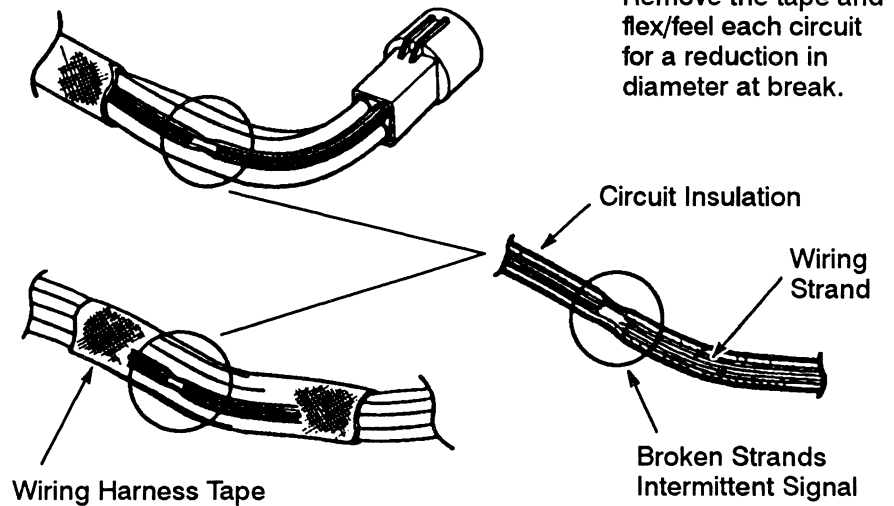

Remove the tape and flex/feel each circuit for a reduction in diameter at break.

Wiring Harness Tape

Circuit Insulation

Wiring Strand

Broken Strands
Intermittent Signal

BROKEN WIRE STRANDS IN HARNESS

100% SATISFACTION GUARANTEED

BUY IT NOW!

Click Here To Order

WITHIN THE HARNESS

2-7 HOW TO USE THIS MANUAL

1994 MUSTANG

HOW TO FIND THE VACUUM CONCERNS

These six steps present an orderly method of troubleshooting.

Step 1. Verify the concern.

- Operate the system and observe all symptoms to check the accuracy and completeness of the customer's complaint.

Step 2. Narrow the concern.

- Narrow down the possible causes and locations of the concern to pinpoint the exact cause.

Step 3. Test the cause.

- Use test procedures to find the specific cause of the symptoms.

Step 4. Verify the cause.

- Confirm that you have found the right cause by operating the parts of the circuit you think are good.

Step 5. Make the repair.

- Repair or replace the inoperative component.

Step 6. Verify the repair.

- Operate the system as in Step 1. Check that your repair has removed all symptoms without creating any new symptoms.

NOTE: Vacuum system problems fall into three groups.

1. Leaks in hoses, connectors or motor diaphragms.

100% SATISFACTION GUARANTEED

BUY IT NOW!

Click Here To Order



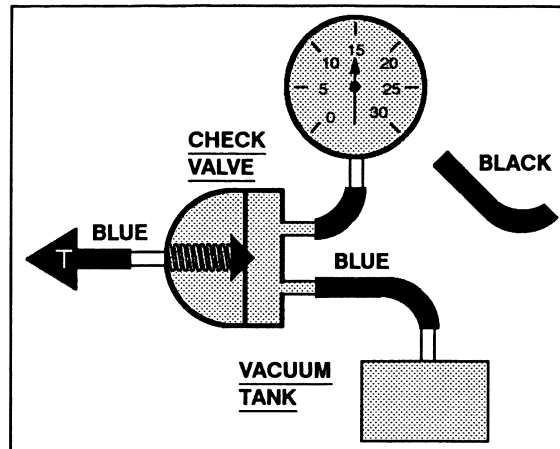

Figure 1 – System Supply Test

Vacuum Supply Test

1. Connect Vacuum Tester to system side of Check Valve (Figure 1).
2. Start engine. Gauge should show approximately 15 inches of vacuum.
3. Turn off engine, and observe gauge:
 - If vacuum holds, supply OK.
 - If vacuum fails, replace Check Valve or Tank.

Leak Test

1. Connect Vacuum Gauge and Vacuum Pump (Figure 2) to system hose in place of tank.
2. Open valve and start pump. Operate control in all modes.
3. Listen for hiss and observe gauge.

NOTE: Hissing is normal at Function Control when changing modes.

If system hisses or loses vacuum, find system leak as follows:

1. Turn on Vacuum Pump and check vacuum build-up.
2. Stop pump; vacuum should drop.
3. Clamp supply hoses with needlenose pliers, one at a time, until vacuum stops dropping (Figure 2).
4. Check vacuum schematic to find components in that line.
5. Clamp hoses through circuit to find leak.

Component Test

1. Connect Vacuum Tester to component.
2. Pump Vacuum Tester. Check that all components operate correctly and vacuum holds.
3. Replace component if vacuum does not hold.

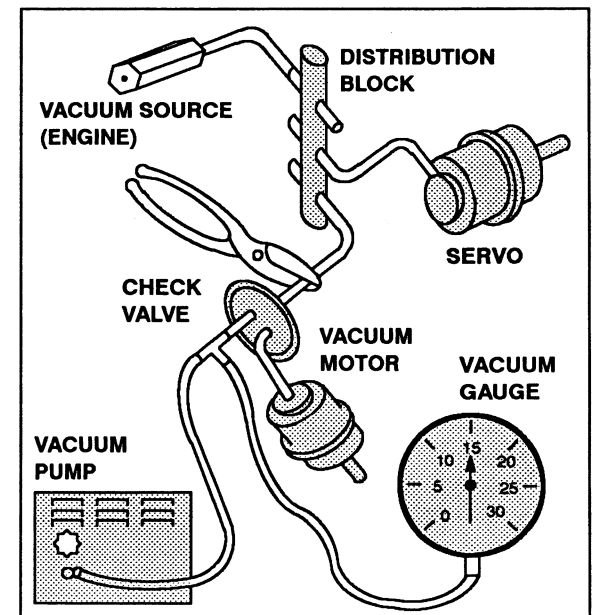
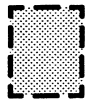
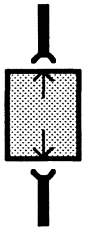

Figure 2 – Testing For Leaks In Typical Vacuum System

ELECTRICAL SYMBOLS



DASHED COMPONENT BOX
ONLY PART OF THE COMPONENT IS SHOWN ON THE PAGE; THE COMPONENT IS SHOWN COMPLETE IN ANOTHER LOCATION



COMPONENT WITH CONNECTORS

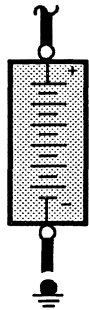

BATTERY

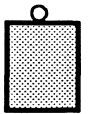

SCREW TERMINAL ON COMPONENT

SOLID STATE

SEALED ELECTRONIC COMPONENT
ANY CIRCUITRY SHOWN INSIDE THE BOX IS A FUNCTIONAL

100% SATISFACTION GUARANTEED

BUY IT NOW!

Click Here To Order

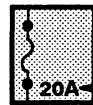

FUSE
CURRENT RATING

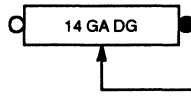

FUSIBLE LINK
WIRE SIZE AND COLOR



MAXI-FUSE or FUSIBLE LINK CARTRIDGE
CURRENT RATING

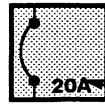

CIRCUIT BREAKER
CURRENT RATING

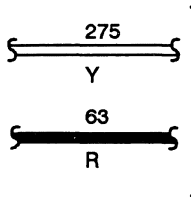

SOLID WIRES

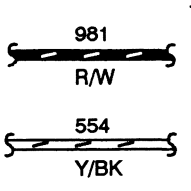

STRIPED WIRES

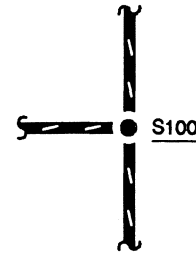

SPLICE OR CRIMP TERMINAL

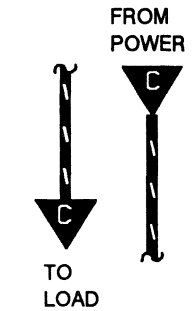

"CUT" WIRES REFERENCED BETWEEN PAGES
ARROWS SHOW CURRENT FLOW FROM POWER TO GROUND



BACKUP LIGHTS

"REFERENCE" WIRES
COMPLETE WIRING SHOWN ON ANOTHER PAGE

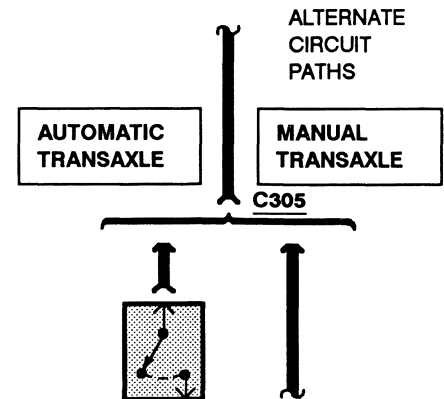

2-9 HOW TO USE THIS MANUAL

1994 MUSTANG

ELECTRICAL SYMBOLS

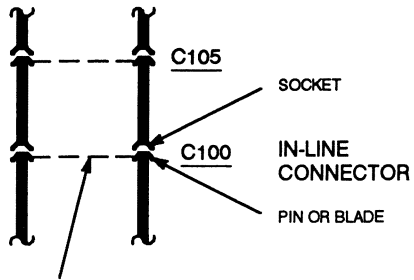

SINGLE DASHED LINE INDICATES THAT WIRE ON LEFT ALSO PASSES THROUGH THE SAME CONNECTOR

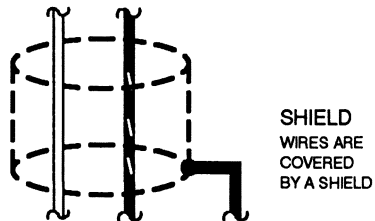
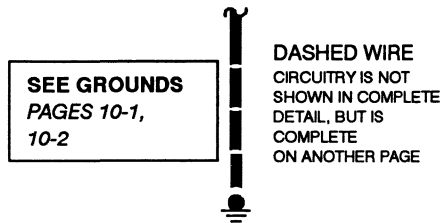

MOTOR



HEATING ELEMENT



THERMISTOR



RHEOSTAT OR POTENTIOMETER



SOLENOID



SWITCH

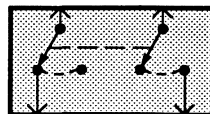

GANGED SWITCHES CONTACTS MOVE AT THE SAME TIME



DIODES CURRENT FLOWS IN DIRECTION OF ARROW ONLY

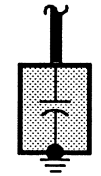

CAPACITOR



TRANSISTOR

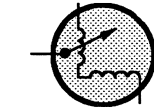

GAUGE



LIGHT EMITTING DIODE (LED)



LIGHT BULB

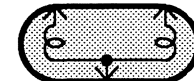

DUAL FILAMENT LIGHT BULB

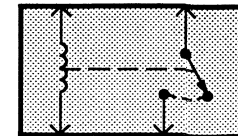

RELAY CONTACTS CHANGE POSITION WITH CURRENT THROUGH COIL

FIELD COIL

SATISFACTION 100% GUARANTEED

BUY IT NOW!

Click Here To Order

VACUUM SYMBOLS

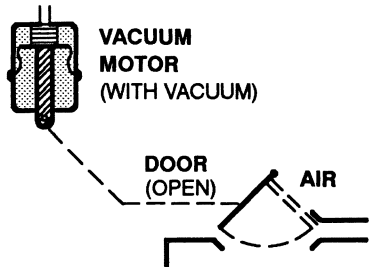
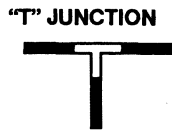

VACUUM ON VACUUM MOTOR PULLS DOOR OPEN TO LET AIR PASS THROUGH

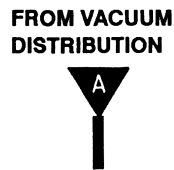
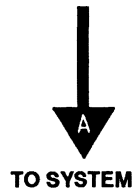

"CUT" HOSES REFERENCED BETWEEN PAGES
ARROW SHOWS FROM MANIFOLD FITTING TO COMPONENT

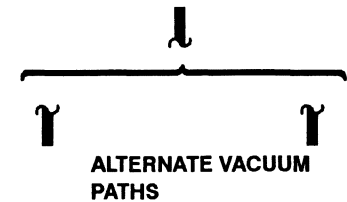

NOTE
Other vacuum symbols used on vacuum system diagrams are fully explained on those pages.

VACUUM MOTOR OPERATION

SINGLE DIAPHRAGM MOTOR

NO VACUUM



VACUUM



SERVO MOTOR

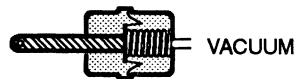

Some vacuum motors, such as the Servo Motor in the Speed Control, can position the actuating arm at any position between fully extended and fully retracted. The Servo is operated by a control valve that applies varying amounts of vacuum to the motor. The higher the vacuum level, the greater the retraction of the motor arm. Servo Motors work nearly the same way as two-position motors, except for the way the vacuum is applied. Servo Motors are generally larger and provide a calibrated control.

DOUBLE DIAPHRAGM MOTOR

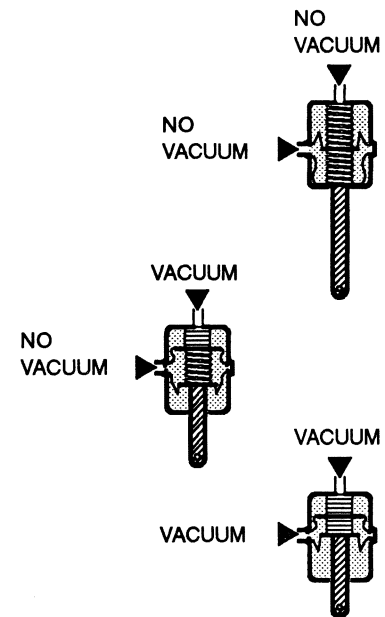

A double diaphragm motor has three positions (it is actually two motors in one housing). When the top port gets vacuum, the shaft pulls halfway in. When both ports get vacuum, the shaft pulls all the way in.

vacuum motors operate like electrical solenoids, mechanically pushing or pulling a shaft. Vacuum is applied in a variety of ways out.

100% SATISFACTION GUARANTEED

BUY IT NOW!

Click Here To Order

10-1 GROUNDS

1994 MUSTANG

All wires are 57 (BK)
unless otherwise noted.

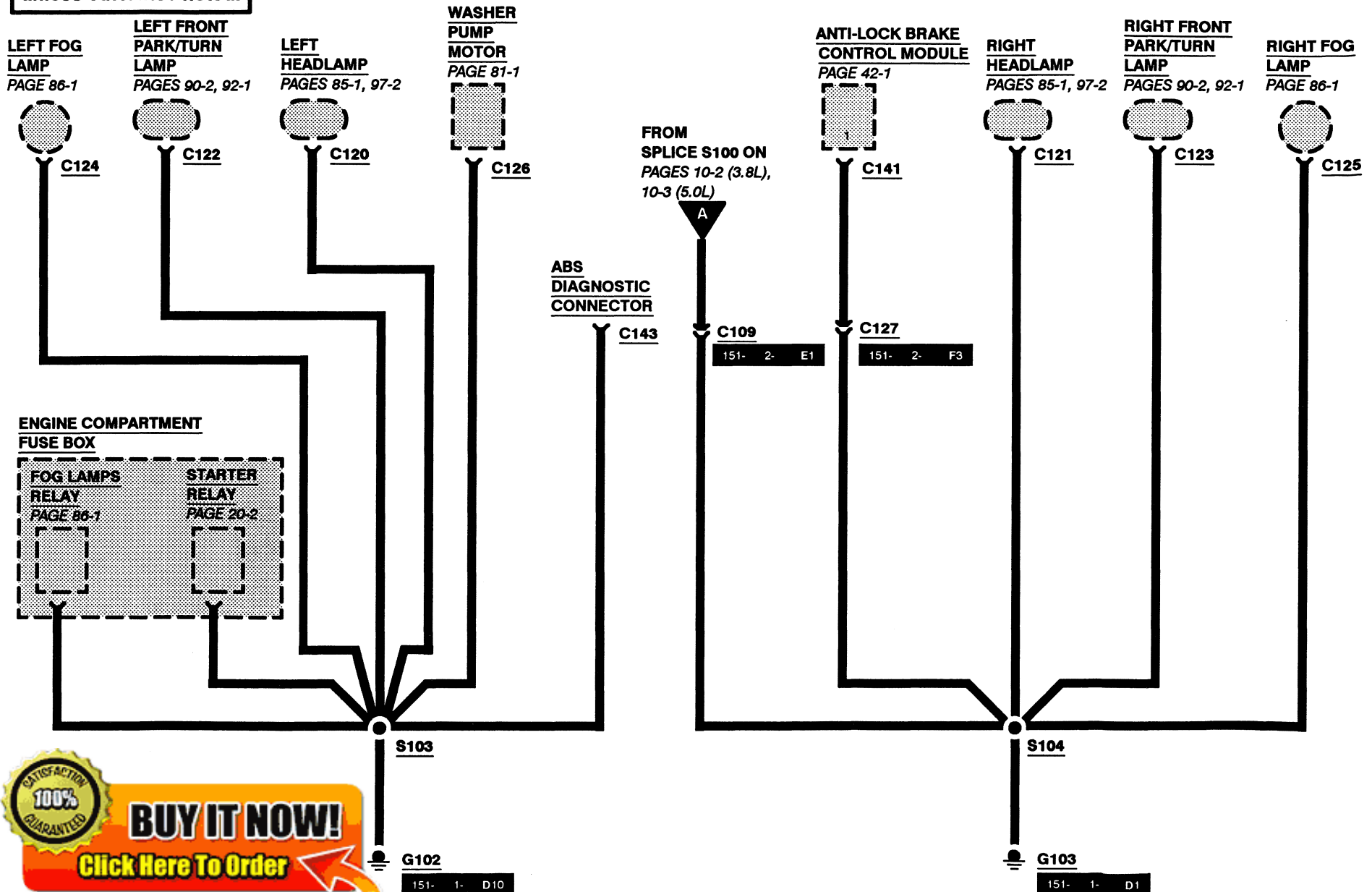

100% SATISFACTION GUARANTEED

BUY IT NOW!

[Click Here To Order](#)

PayPal American Express Discover MasterCard VISA

GROUNDS 10-2

1994 MUSTANG

3.8L

All wires are 57 (BK) unless otherwise noted.

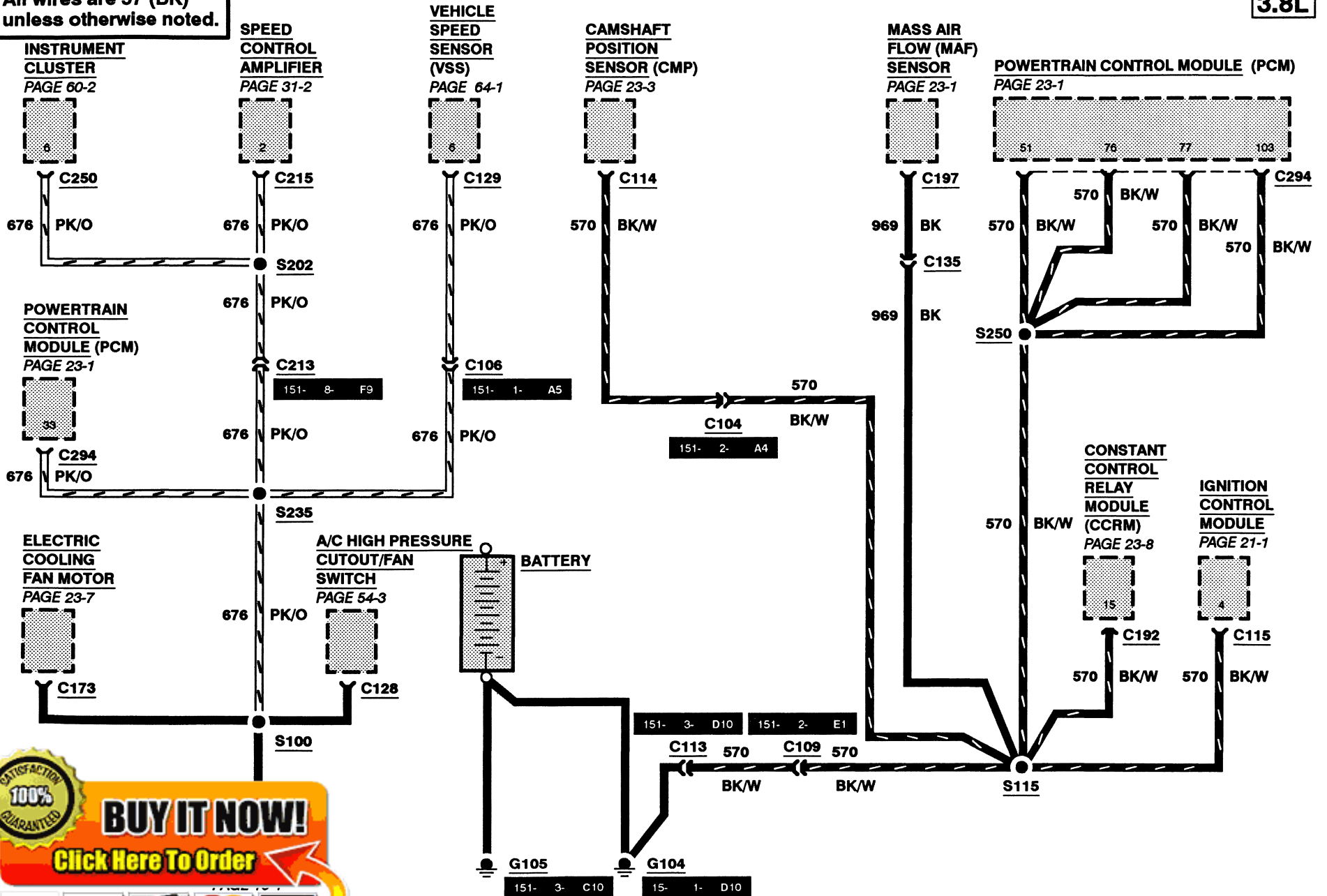

100% SATISFACTION GUARANTEED

BUY IT NOW!

Click Here To Order

PayPal, American Express, Discover, MasterCard, VISA

All wires are 57 (BK) unless otherwise noted.

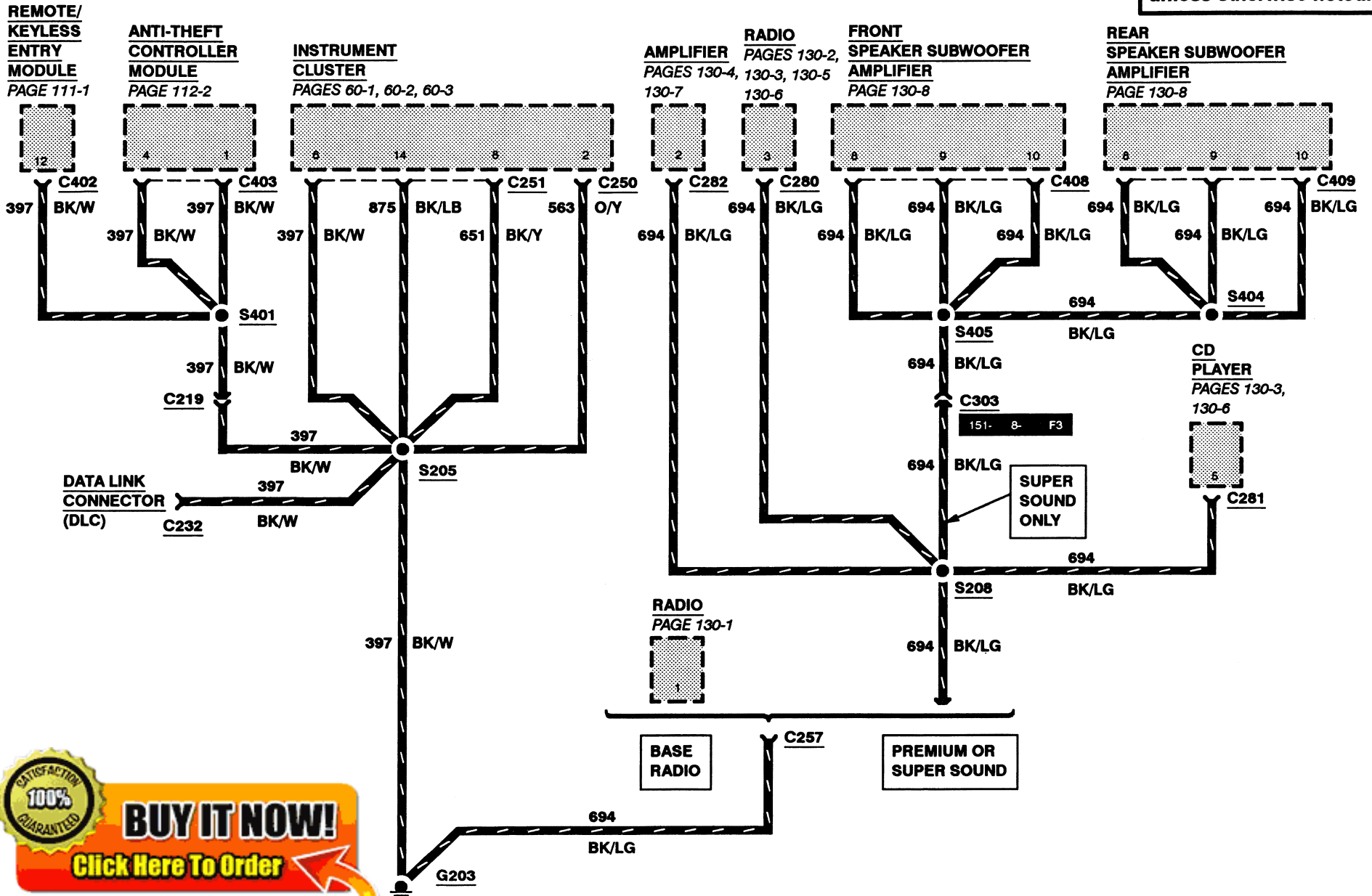

100% SATISFACTION GUARANTEED

BUY IT NOW!

Click Here To Order

PayPal, American Express, Discover, MasterCard, VISA

10-5 GROUNDS

1994 MUSTANG

All wires are 57 (BK) unless otherwise noted.

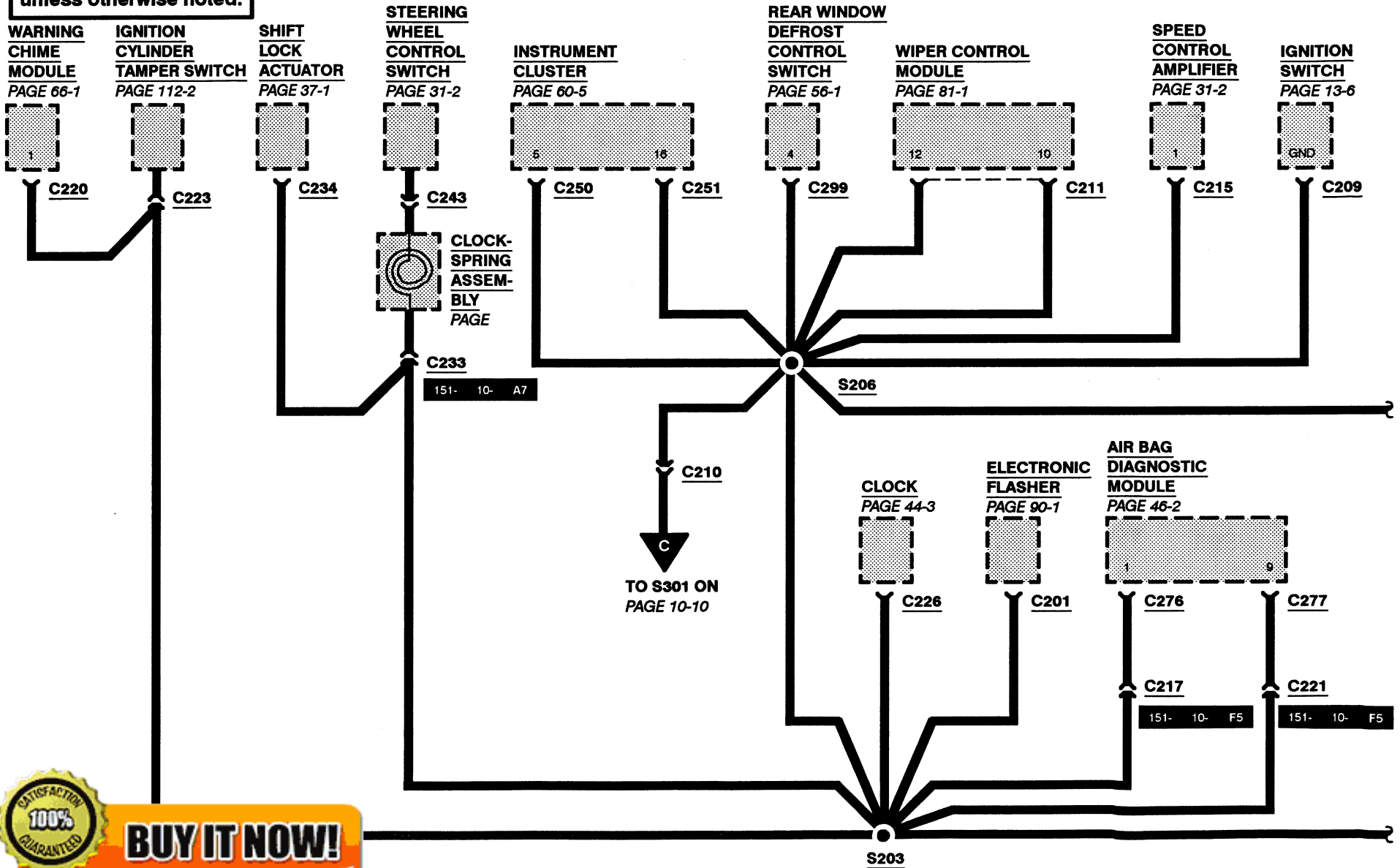

100% SATISFACTION GUARANTEED

BUY IT NOW!

Click Here To Order

GROUNDS 10-6

1994 MUSTANG

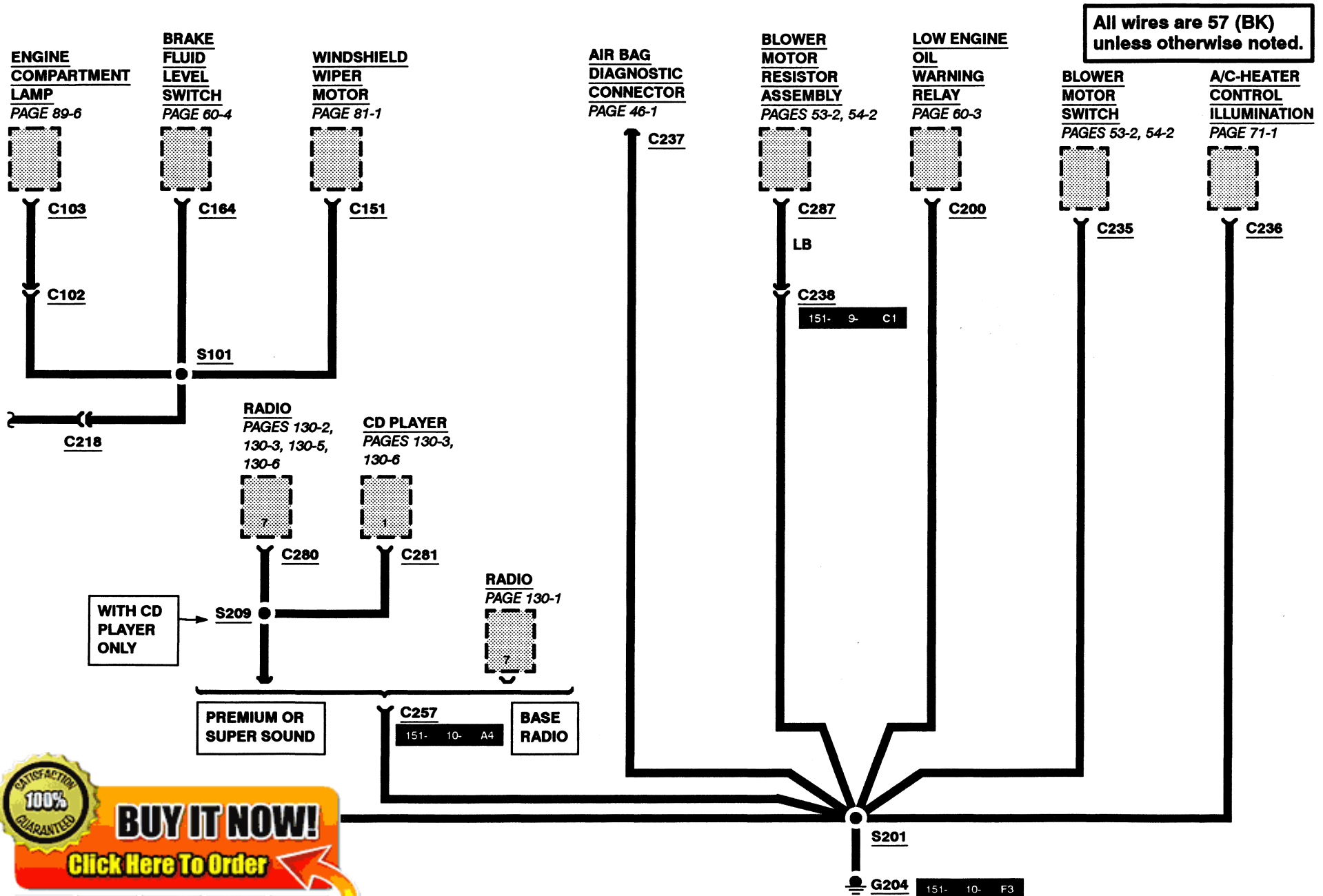

100% SATISFACTION GUARANTEED

BUY IT NOW!

Click Here To Order

10-7 GROUNDS

1994 MUSTANG

All wires are 57 (BK) unless otherwise noted.

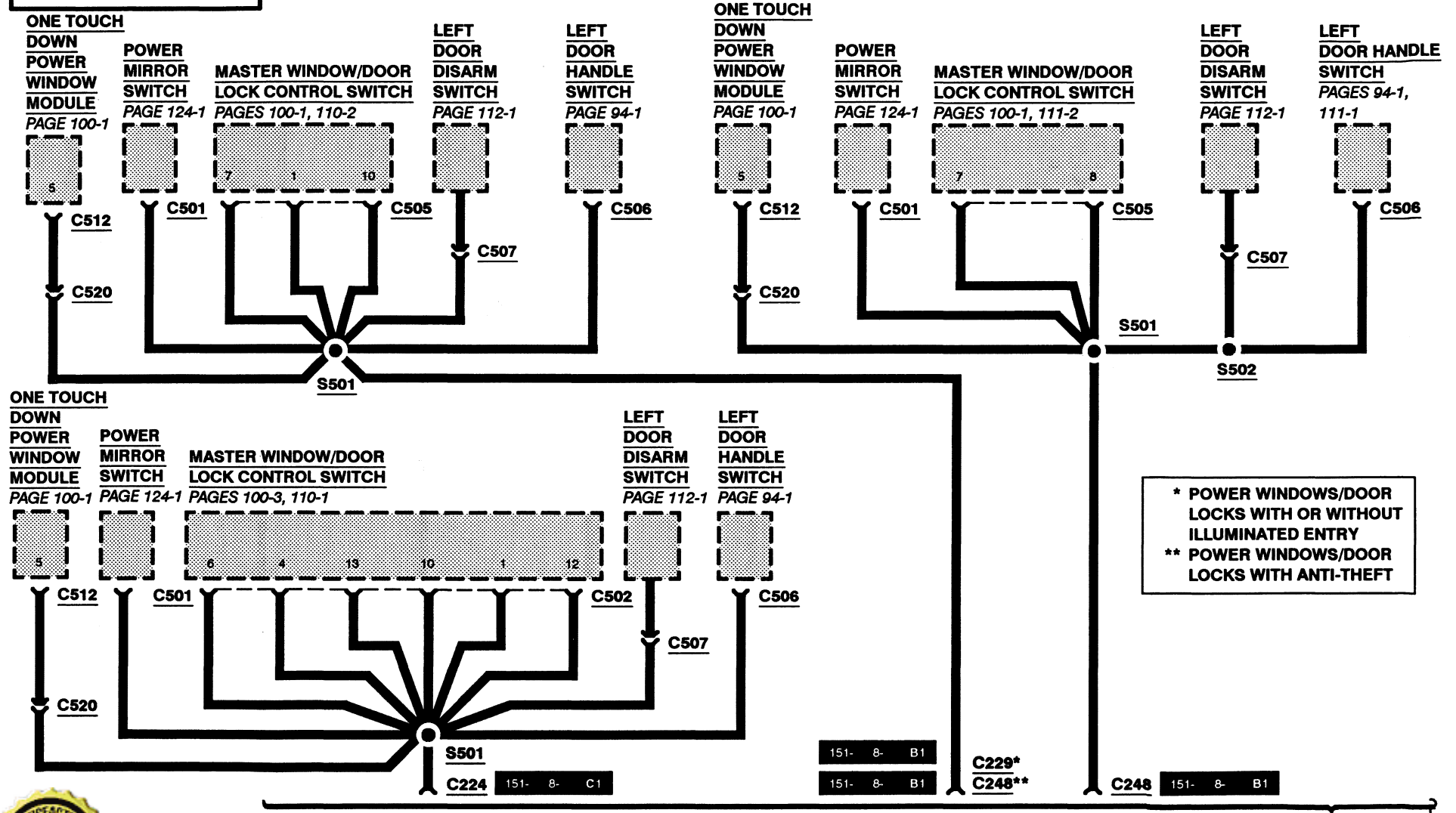

100% SATISFACTION GUARANTEED

BUY IT NOW!

Click Here To Order

PayPal, American Express, Discover, MasterCard, VISA

COUPE

POWER WINDOWS/DOOR LOCKS WITH OR WITHOUT ILLUMINATED ENTRY OR ANTI-THEFT

CONVERTIBLE

POWER WINDOWS/DOOR LOCKS WITH REMOTE/KEYLESS ENTRY

TO SPLICE S301 ON PAGE 10-10

* WITHOUT POWER
WINDOWS/DOOR LOCKS
** WITH POWER WINDOWS/
DOOR LOCKS

All wires are 57 (BK)
unless otherwise noted.

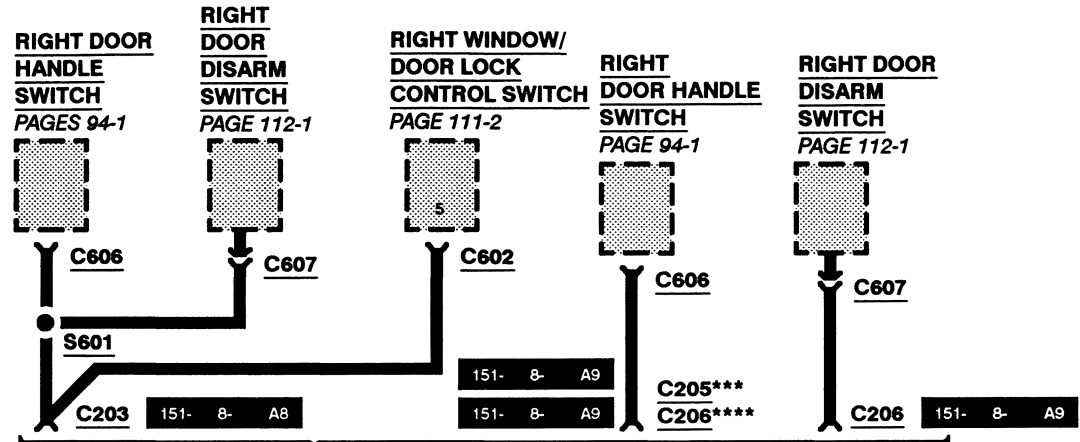

WITH ANTI-THEFT ,
REMOTE/KEYLESS
ENTRY AND ILLUMI-
NATED ENTRY

WITH ILLUMINATED ENTRY

WITH ANTI-THEFT

TO C208 ON
PAGE 10-9

TO S302 ON
PAGE 10-9

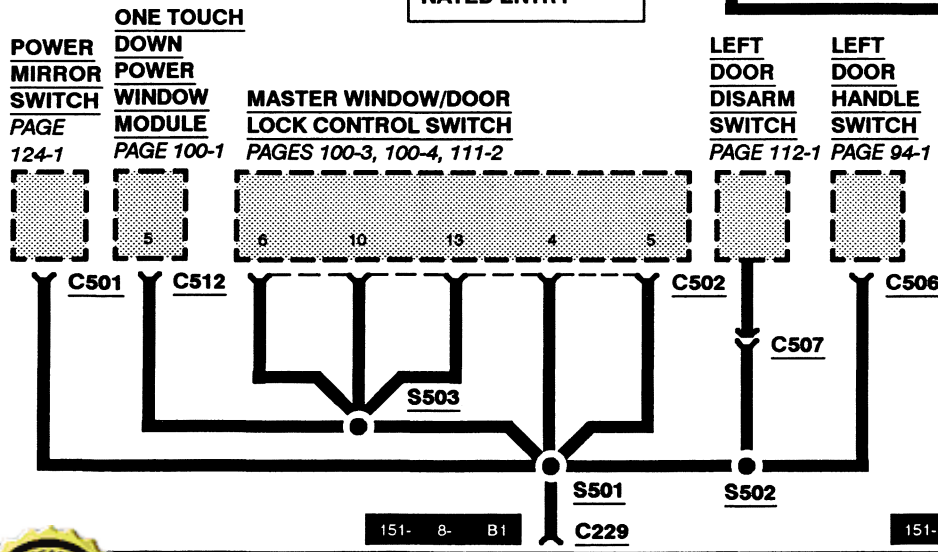

COUPE

WITH POWER WINDOWS/DOOR LOCKS
NOTE KEYLESS ENTRY

COUPE WITHOUT
POWER WINDOWS/
DOOR LOCKS

WITH ILLUMINATED
ENTRY ONLY

100% SATISFACTION GUARANTEED

BUY IT NOW!

Click Here To Order

PayPal, American Express, Discover, MasterCard, VISA

10-9 GROUNDS

1994 MUSTANG

All wires are 57 (BK) unless otherwise noted.

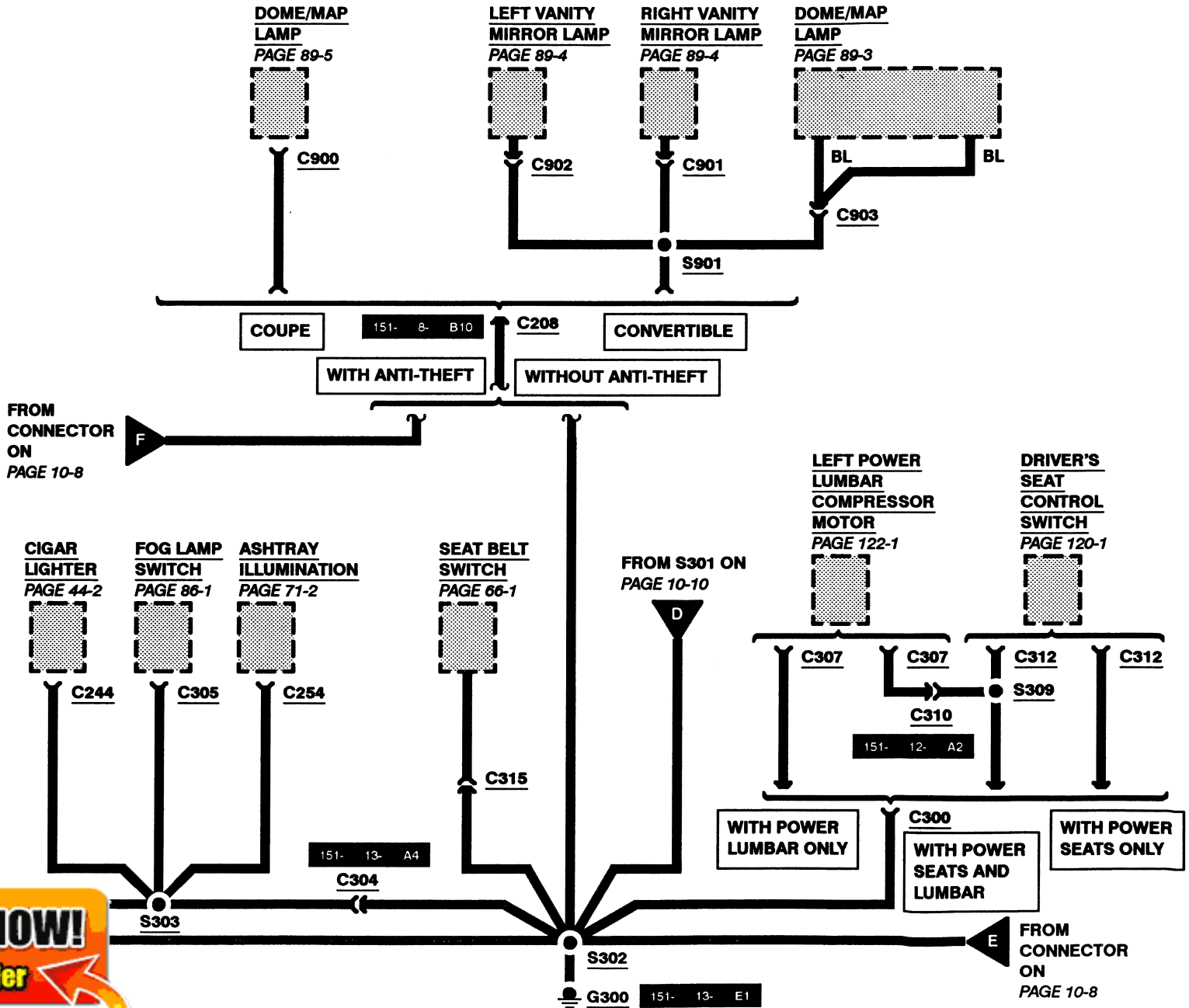

100% SATISFACTION GUARANTEED

BUY IT NOW!

Click Here To Order

All wires are 57 (BK) unless otherwise noted.

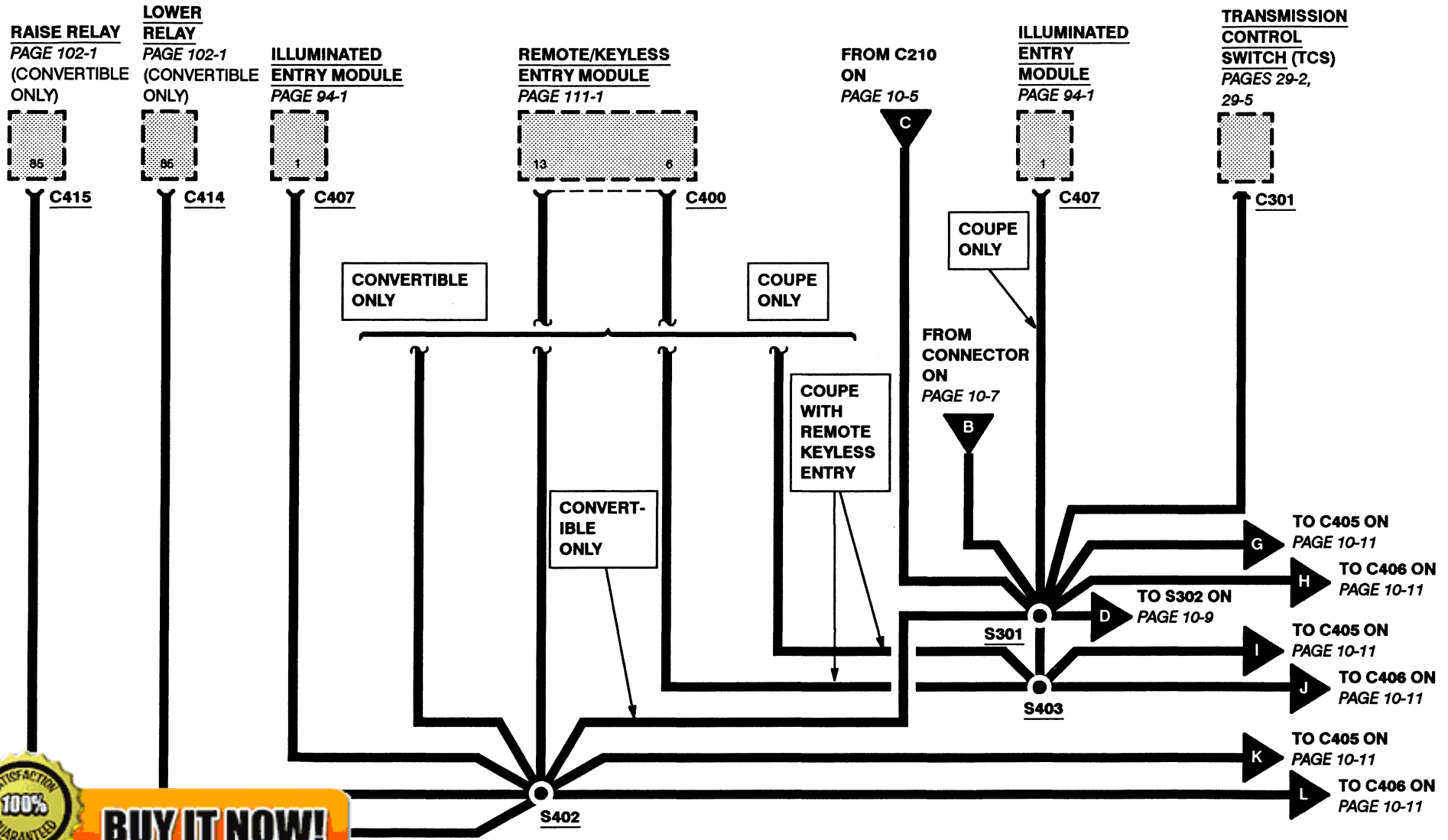

100% SATISFACTION GUARANTEED

BUY IT NOW!

Click Here To Order

10-11 GROUNDS

1994 MUSTANG

All wires are 57 (BK) unless otherwise noted.

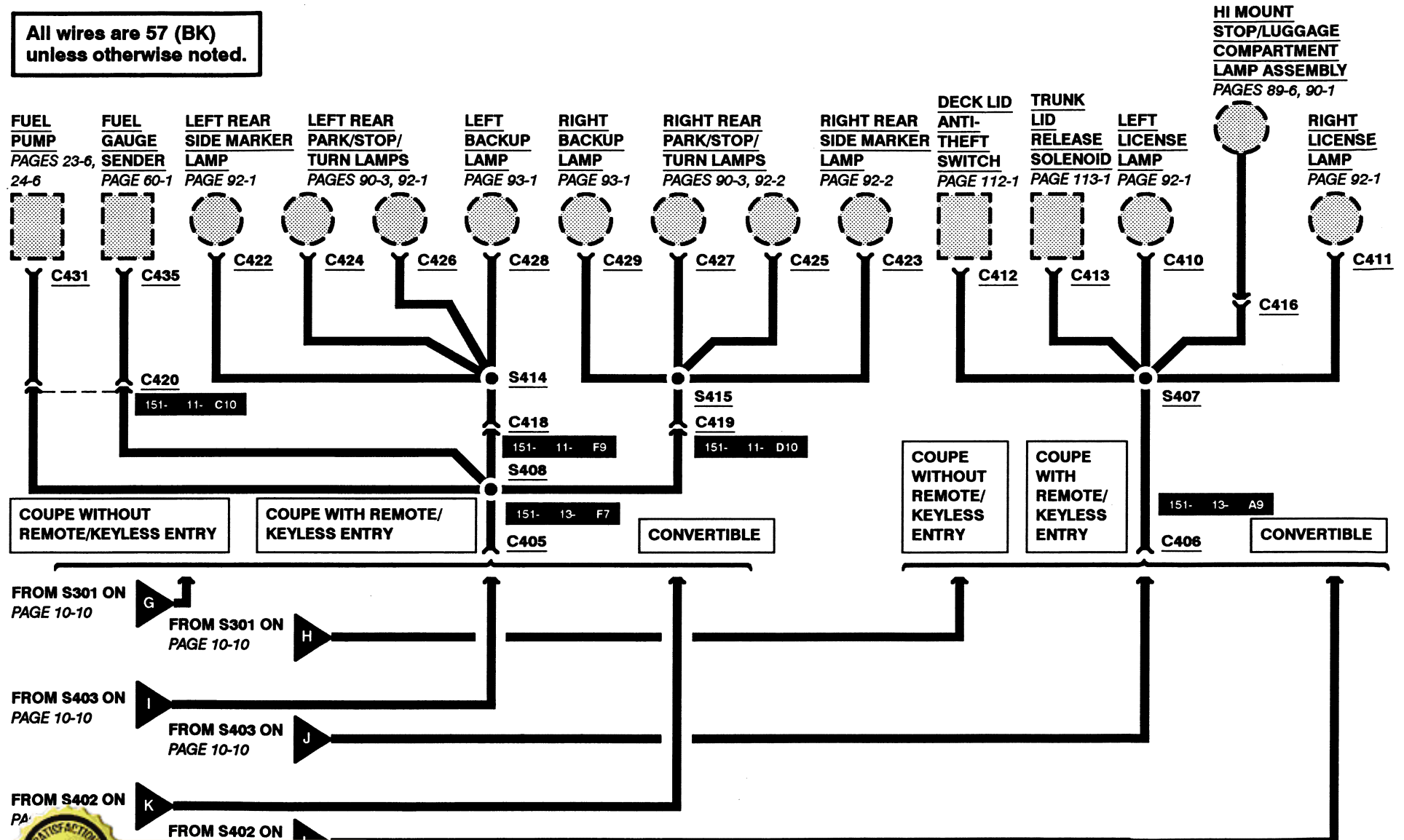

100% SATISFACTORY GUARANTEED

BUY IT NOW!

Click Here To Order

Refer to Location Index, Cell 152, for Component, Connector, Splice, Ground and Base Part Number descriptions and locations.

100% SATISFACTION GUARANTEED

BUY IT NOW!

Click Here To Order

PayPal American Express Cards DISCOVER NOVUS MasterCard VISA

11-1 CIRCUIT PROTECTION/FUSE PANEL

1994 MUSTANG

CIRCUIT PROTECTION DEVICES

Electrical circuits on this vehicle may be protected by fuses, fusible links, fusible link cartridges, circuit breakers, or a combination of these devices.

BLADE TYPE FUSE

TOP VIEW

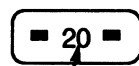

AMPERE RATING

SIDE VIEW

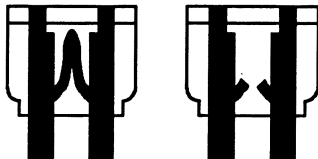

GOOD FUSE

BLOWN FUSE

Blade type fuses have a transparent plastic housing. To check a fuse, pull it from the fuse panel and look at the fuse element through the housing. Always replace a blown fuse with a new fuse that has the same ampere rating.

The ampere rating of a blade type fuse can also be determined by following the color code shown here:

BLADE FUSE COLOR CODING	
AMPERE RATING	HOUSING COLOR
4	Pink
5	Tan
10	Red



BUY IT NOW!
Click Here To Order

FUSIBLE LINK

CUT-AWAY VIEW

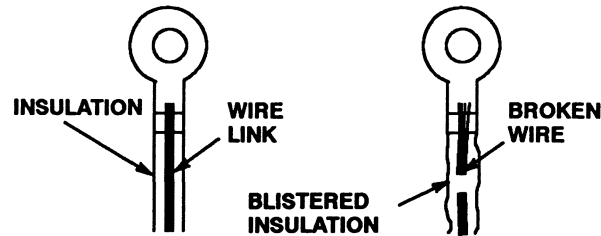

GOOD LINK

BLOWN LINK

Fusible links are short lengths of wire that are smaller in diameter than the wires they are protecting. Fusible link wire is covered with a special thick, non-flammable insulation. An overload condition causes the insulation to blister. If the overload condition continues, the wire link will melt. To check a fusible link, look for blistered insulation. If the insulation is okay, pull lightly on the wire; if the fusible link stretches, the wire has melted.

When replacing fusible links, first cut the protected wire where it is connected to the fusible link. Then, tightly crimp or solder the new link to the protected wire.

Fusible links are often identified by color coding of the insulation, as shown here:

FUSIBLE LINK COLOR CODING	
WIRE LINK SIZE	INSULATION COLOR
20 GA	Blue
18 GA	Brown or Red
16 GA	Black or Orange
14 GA	Green
12 GA	Gray

FUSIBLE LINK CARTRIDGE

SIDE VIEW



GOOD



BLOWN

TOP VIEW

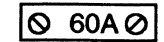

AMPERE RATING

Fusible link cartridges have a transparent colored plastic housing. To check a fusible link cartridge, look at the fuse element through the side of the housing.

To replace a fusible link cartridge, pull it from the fuse box or panel. Always replace a blown fusible link cartridge with a new one having the same ampere rating.

The ampere rating of a fusible link cartridge can also be determined by following the color code shown here:

FUSIBLE LINK CARTRIDGE COLOR CODING	
AMPERE RATING	HOUSING COLOR
30	Light Green
40	Amber
50	Red
60	Blue





Click Here To Order

BUY IT NOW!



**TECHNICAL
PUBLICATIONS DEPARTMENT**
Ford Customer Service Division



FPS-12121-94

LITHO IN U.S.A.
September 1993

Copyright © 1993
Ford Motor Company