

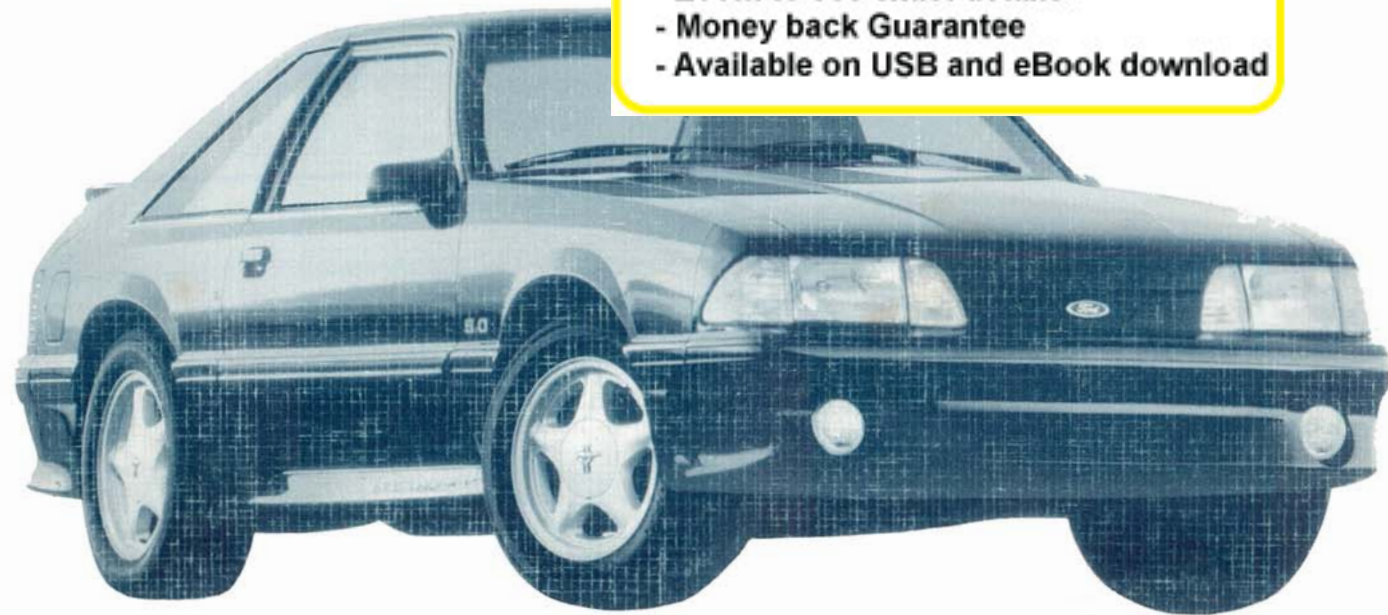

2 MUSTANG

Electrical & Vacuum Trouble- Shooting Manual



DEMO

This DEMO contains only a few pages of the entire manual/product.

Not all Bookmarks work on the Demo, but they do on the full version.

Features:

- Searchable text
- Printable pages
- Bookmarked for easy navigation
- High Resolution images
- Zoom to see exact details
- Money back Guarantee
- Available on USB and eBook download



License #84356800

Copyright © 2023, Forel Publishing Company, LLC, Woodbridge, Virginia

All Rights Reserved. No part of this book may be used or reproduced in any manner whatsoever without written permission of Forel Publishing Company, LLC. For information write to Forel Publishing Company, LLC, Woodbridge, VA 22192

**1992 Mustang Electrical & Vacuum
Trouble-Shooting Manual (EVTM)
EAN: 978-1-60371-416-7
ISBN: 1-60371-416-2**

Forel Publishing Company, LLC
Woodbridge, VA 22192
Email: sales@ForelPublishing.com
<https://www.ForelPublishing.com>



This publication contains material that is reproduced and distributed under a license from Ford Motor Company. No further reproduction or distribution of the Ford Motor Company material is allowed without the express written permission of Ford Motor Company.

Note from the Publisher

This product was created from the original Ford Motor Company's publication. Every effort has been made to use the original scanned images, however, due to the condition of the material; some pages have been modified to remove imperfections.

Disclaimer

Although every effort was made to ensure the accuracy of this book, no representations or warranties of any kind are made concerning the accuracy, completeness or suitability of the information, either expressed or implied. As a result, the information contained within this book should be used as general information only. The author and Forel Publishing Company, LLC shall have neither liability nor responsibility to any person or entity with respect to any loss or damage caused, or alleged to be caused, directly or indirectly by the information contained in this book. Further, the publisher and author are not engaged in rendering legal or other professional services. If legal, mechanical, electrical, or other expert assistance is required, the professional should be sought.



ELECTRICAL AND VACUUM TROUBLESHOOTING MANUAL FPS-12121-92

FORD PARTS and SERVICE DIVISION

Quality is Job 1

Ford Parts and Service Division has developed a new format for the EVTM for the 1992 Mustang. Our goal is to provide accurate and timely electrical and vacuum service information.

1992 EVTM FEATURES

- **“HOW THE CIRCUIT WORKS”** descriptions that explain how each circuit works. These descriptions are designed to be used in conjunction with the Electrical Schematic.
- **Schematic pages** now contain **COMPONENT LOCATION** references to full-view illustrations.
- **“COMPONENT TESTING”** procedures (CELL 149) that tell the user how to perform diagnostic tests on various circuits.
- **Connector End Views** (**“COMPONENT CONNECTOR FACES”** CELL 150) are shown for connectors with five or more cavities; and for connectors with ten or more cavities, a circuit function chart is provided.
- **NOTES, CAUTIONS and WARNINGS** that contain important safety information.
- Full view **“COMPONENT LOCATION VIEWS”** (CELL 151) to help locate on-vehicle components.
- **Component Base Part Numbers** and **Harness Base Part Numbers** to aid in ordering parts.
- **Cellular Pagation:** A specific section (or cell) in all EVTMs is numbered by cell and starts with page 1. For example: **“HOW TO USE THIS MANUAL”** is CELL 2 and begins with page 2-1.

igned for all electrical connectors. **“C”** numbers are listed
re listed in numerical order in the **“LOCATION INDEX”**

” – A feedback sheet is provided on the last page.

ORDERING INFORMATION

Information about how to order additional copies of this publication or other Ford publications may be obtained by writing to Helm Incorporated at the address shown below or by calling 1-800-782-4356. Other publications available include:

- Shop Manuals
- Service Specification Books
- Car/Truck Wiring Diagrams
- Powertrain Control/Emissions Diagnosis Manuals

Helm Incorporated
P.O. Box 87150
Detroit, Michigan 48207



1-1 TABLE OF CONTENTS/INDEX

Table of Contents	
How to Use This Manual	2-1
Troubleshooting/Descriptions	7-1
Grounds	10-1
Circuit Protection/Fuse Panel	11-1
Charging System	12-1
Power Distribution	13-1
Starting System	20-1
Ignition System	21-1
Electronic Engine Control (2.3L EFI)	23-1
Electronic Engine Control (5.0L)	24-1
Speed Control	31-1
Cooling Fans	33-1
Shift Lock	37-1
Horn/Cigar Lighter	44-1
Air Bag Restraint System	46-1
Heater	53-1
Air Conditioner/Heater	54-1
Rear Window Defrost	56-1
Instrument Cluster	60-1
Vehicle Speed Sensor (VSS)	64-1
Warning Chime	66-1
Instrument Illumination	71-1
Interval Wiper/Washer	81-1
Headlamps	85-1
Fog Lamps	86-1
Courtesy Lamps	89-1
Turn/Stop/Hazard Lamps	90-1
Exterior Lamps	92-1
Backup Lamps	93-1
Daytime Running Lamps	97-1
Power Windows	100-1
Convertible Top	102-1
Power Door Locks	110-1
Lid Release	113-1
	122-1
	124-1
	130-1
	142-1
	149-1

Connector Faces	150-1
Component Location Views	151-1
Location Index	152-1
Vehicle Repair Location Codes	160-1

Index	
Air Bag Restraint System	46-1
Air Conditioner/Heater	
Vacuum	54-1
Electrical	
2.3L	54-2
5.0L	54-4
Backup Lamps	93-1
Charging System	12-1
Cigar Lighter	44-1
Circuit Protection/Fuse Panel	11-1
Component Location Views	151-1
Component Testing	
A/C-Heater Control	149-6
Blower Motor Switch	149-7, 149-8
Hazard Warning Switch	149-5
Heater Control	149-7
Ignition Switch	149-2
Introduction	149-1
Main Light Switch	149-1
Multi-Function Switch	149-3, 149-4
Connector Faces/Pinout Charts	150-1
Convertible Top	102-1
Cooling Fans	33-1
Courtesy Lamps	89-1
Daytime Running Lamps	97-1
Defrost (Rear Window)	56-1
Door Locks (Power)	110-1
Electronic Engine Control	
2.3L	23-1
5.0L	24-1
Exterior Lamps	92-1
Fog Lamps	86-1
Fuse Panel	
Fuse 1	13-4

Fuse 2	13-3
Fuse 4	13-4, 13-10
Fuse 5	13-3, 13-9
Fuse 6	13-3, 13-6
Fuse 7	13-4
Fuse 8	13-4, 13-5
Fuse 9	13-3
Fuse 10	13-4, 13-6
Fuse 11	13-3
Fuse 12	13-4
Fuse 13	13-10
Circuit Breaker 14	13-3
Fuse 15	86-1
Fuse 16	13-4
Fuse 18	13-3, 13-10
Gauges	
Fuel	60-2
Oil Pressure	60-2
Tachometer	60-2
Temperature	60-2
Voltmeter	60-2
Grounds	
G100	10-5
G102	10-1
G103	10-1
G104	
2.3L	10-3
5.0L	10-4
G105	
2.3L	10-3
5.0L	10-4
G106	10-3
G200	10-2
G201	
2.3L	10-3
5.0L	10-4
G301	10-8
G400	10-8
G401	10-9
G402	10-9
G500	10-7

100% SATISFACTION GUARANTEED

BUY IT NOW!

Click Here To Order

TABLE OF CONTENTS/INDEX 1-2

Headlamps	85-1	Lamps (Interior)	
Heater	53-1	Cargo	89-1
Horn	44-1	Courtesy	89-1
Ignition Switch	13-3	Dome	89-2
Ignition System	21-1	Engine Compartment	89-1
2.3L	21-1	Glove Box Lamp	89-2
5.0L	21-3	Instrument Illumination	71-2
Indicators		Luggage Compartment	89-1
Air Bag	60-3	Map	89-2
Brake	60-3	Vanity Mirror	89-2
Charge	60-1	Location Index	152-2
"Check Engine"	60-3	Main Light Switch	13-10
"Check Oil"	60-3	Mirrors (Power)	124-1
Fasten Belts	60-1	Power Distribution	13-1
Hi Beam	60-1	Power Door Locks	
Left Turn	60-1	Convertible	110-3
Low Coolant	60-3	2 and 3 Door	110-1
Right Turn	60-1	Power Lumbar Seats	122-1
Instrument Cluster	60-1	Power Mirrors	124-1
Instrument Illumination	71-1	Power Windows	
Interval Wiper/Washer	81-1	Convertible	100-1
Lamps (Exterior)		2 and 3 Door	100-3
Backup	93-1	Radio	
Daytime Running	97-1	AM/FM Stereo	130-5
Fog	86-1	Premium Sound	130-1
Exterior	92-1	Premium Sound with	
Hazard	90-1	Graphic Equalizer	130-3
Headlamps	85-1	Rear Window Defrost	56-1
License	92-1	Seats (Lumbar)	122-1
Park		Shift Lock	37-1
Front	92-1	Speed Control	31-1
Rear	92-2	Starting System	20-1
Side Marker		Trunk Lid Release	113-1
Front	92-1	Turn/Stop/Hazard Lamps	90-1
Rear	92-2	Vacuum Distribution	142-1
Rear	90-2	Vehicle Repair Location Codes	160-1
Rear	90-3	Vehicle Speed Sensor (VSS)	64-1
Rear	90-1	Warning Chime	66-1
Rear	90-1	Windows (Power)	100-1
		Wiper/Washer (Interval)	81-1

IMPORTANT SAFETY NOTICE

Appropriate service methods and proper repair procedures are essential for the safe, reliable operation of all motor vehicles, as well as the personal safety of the individual doing the work. This Manual provides general directions for accomplishing service and repair work with tested, effective techniques. Following them will help assure reliability.

There are numerous variations in procedures, techniques, tools, and parts for servicing vehicles, as well as in the skill of the individual doing the work. This Manual cannot possibly anticipate all such variations and provide advice or cautions as to each. Accordingly, anyone who departs from the instructions provided in this Manual must first establish that he compromises neither his personal safety nor the vehicle integrity by his choice of methods, tools or parts.



2-1 HOW TO USE THIS MANUAL

The purpose of this manual is to show electrical and vacuum circuits in a clear and simple fashion to make troubleshooting easier. **NOTES**, **CAUTIONS** and **WARNINGS** containing important information appear in boxes on text pages.

- **NOTES** describe how switches and other components operate to help complete a particular procedure.
- **CAUTIONS** provide information that could prevent making an error that may damage the vehicle.
- **WARNINGS** provide information to prevent personal injury.

The **WARNINGS** list on page 2-2 contains general warnings to follow when servicing a vehicle.

Components that work together are shown together. All electrical components used in a specific system are shown on one diagram. The circuit breaker or fuse is shown at the top of the page. All wires, connectors, components and splices are shown in the flow of current to ground at the bottom of the page. If a component is used in several different systems, it is shown in several places. For example, the Main Light Switch is electrically a part of many systems and is repeated on many pages.

In some cases, a component may seem (by its name) to belong to a system where it has no electrical connection. For example, illumination is electrically part of Instrument Panel electrical circuitry, but it is not

are reverse-text blocks located next to each component and connector and refer the user to the appropriate illustration page and zone.

“**GROUNDINGS**” (Cell 10) contains ground circuitry shown in complete detail. This information is useful for checking interconnections of the ground circuits of different systems.

“**POWER DISTRIBUTION**” (Cell 13) contains power distribution circuitry shown in complete detail. This section displays how the various fuses are powered and, in turn, how each system is powered.

“**COMPONENT LOCATION VIEWS**” (Cell 151) contains full-view illustrations which show the location of all components and connectors in the vehicle.

“**TROUBLESHOOTING/DESCRIPTIONS**” (Cell 7) contains descriptions of **HOW THE CIRCUIT WORKS** and **TROUBLESHOOTING HINTS** for each system as well as references to the appropriate diagnostic section of the Shop Manual. The beginning of each section has a reverse-text block identifying the page on which the corresponding schematic appears. The first page of each system schematic has a reference box identifying the corresponding page in Cell 7.

“**COMPONENT TESTING**” (Cell 149) contains testing procedures for various switches. This information includes schematics, component terminal locations and step-by-step procedures.

“**CONNECTOR FACES**” (Cell 150) contains illustrations of all component connectors that have 5 or more terminals. Component connectors with more than 10 terminals are accompanied by a pinout chart that lists the

function of all circuitry associated with that component.

The “**LOCATION INDEX**” (Cell 152) provides the base part numbers, locations, connector face reference and illustration references for all components, connectors, splices and grounds.

HELPFUL REMINDERS

Before using the EVTM for troubleshooting, refer to the **HELPFUL REMINDERS** described on this page.

1. The abbreviation T/O, for take out, used in the Component Location Chart, refers to the point at which a harness branches to feed a component. Refer to the wiring harness illustration.

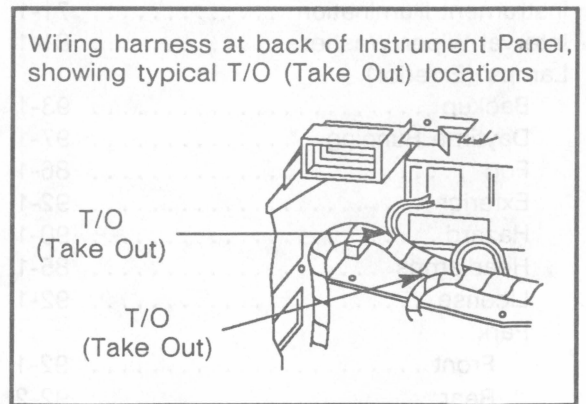

2. If a connector serves the same purpose in two separate versions (e.g., EFI/Carb), but is physically different, two connector numbers are used. However, if a connector serves the same purpose in two separate versions (e.g., EFI/Carb) and is physically the same, but the wire colors

100% SATISFACTION GUARANTEED

BUY IT NOW!

Click Here To Order

PayPal American Express Discover MasterCard VISA

2-3 HOW TO USE THIS MANUAL

HOW TO FIND ELECTRICAL CONCERNS

Step 5. Make the repair.

- Repair or replace the inoperative component.

Step 6. Verify the repair.

- Operate the system as in Step 1 and check that your repair has removed all symptoms without creating any new symptoms.

Some engine circuits may need special test equipment and special procedures. See the *Shop Manual* and other service books for details. You will find these circuits in this manual to be helpful with these special tests.

TROUBLESHOOTING TOOLS

JUMPER WIRE

This is a test lead used to connect two points of a circuit. A Jumper Wire can complete a circuit, bypassing an open.

WARNING

Never use a jumper wire across loads (motors, etc.) connected between hot and ground. This direct battery short may cause injury or fire.

VOLTMETER

A Voltmeter measures circuit voltage.

to ground, the measur-

BUY IT NOW!

Click Here To Order

OHMMETER

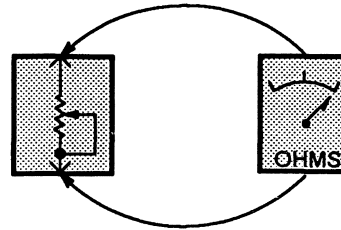

Figure 1—Resistance Check

An Ohmmeter shows the resistance between two connected points (Figure 1).

TEST LAMP

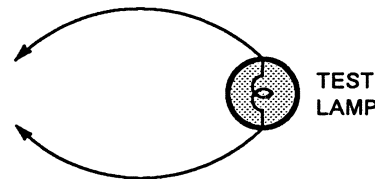

Figure 2—Test Lamp

A Test Light is a 12-volt bulb with two test leads (Figure 2).

Uses: Voltage Check, Short Check.

SELF-POWERED TEST LAMP

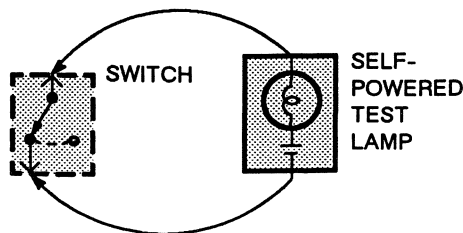

Figure 3—Continuity Check

The Self-Powered Test Lamp is a bulb, battery and set of test leads wired in series (Figure 3). When connected to two points of a continuous circuit, the bulb glows.

Uses: Continuity Check, Ground Check.

CAUTION

When using a self-powered test lamp or ohmmeter, be sure power is off in circuit during testing. Hot circuits can cause equipment damage and false readings.

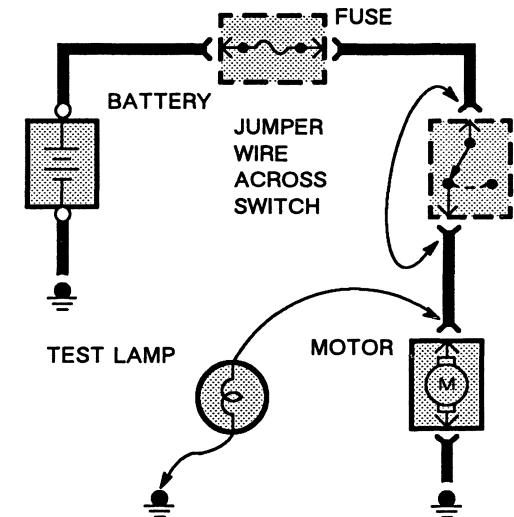

Figure 4—Switch Circuit Check and Voltage Check

In an inoperative circuit with a switch in series with the load, jumper the terminals of the switch to power the load. If jumpering the terminals powers the circuit, the switch is inoperative (Figure 4).

100% SATISFACTION GUARANTEED

BUY IT NOW!

Click Here To Order

PayPal, American Express, Discover, MasterCard, VISA

HOW TO FIND ELECTRICAL CONCERNS (CONTINUED)

CONTINUITY CHECK (Locating open circuits)

Connect one lead of Self-Powered Test Lamp or Ohmmeter to each end of circuit (Figure 3). Lamp will glow if circuit is closed. Switches and fuses can be checked in the same way.

VOLTAGE CHECK

Connect one lead of test lamp to a known good ground or the negative (-) battery terminal. Test for voltage by touching the other lead to the test point. Bulb goes on when the test point has voltage (Figure 4).

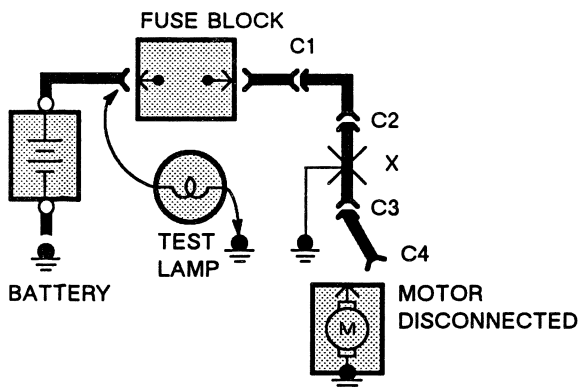

Figure 5—Short Check

A fuse that repeatedly blows is usually caused by a short to ground. It's important to locate such a short quickly (Figure

ough the
through

100% SATISFACTORY GUARANTEED

BUY IT NOW!

Click Here To Order

FOR USE:

PayPal American Express Cards Discover NOVUS MasterCard VISA

- Motors: disconnect motor connector (Connector C4 in Figure 5).
 - Lights: remove bulbs.
3. Turn Ignition Switch to RUN (if necessary) to power fuse.
 4. Connect one Test Lamp lead to hot end of blown fuse. Connect other lead to ground. Bulb should glow, showing power to fuse. *(This step is just a check to be sure you have power to the circuit.)*
 5. Disconnect the test lamp lead that is connected to ground, and reconnect it to the load side of the fuse at the connector of the disconnected component. (In Figure 5, connect the test lamp lead to connector C4.)
 - If the Test Lamp is off, the short is in the disconnected component.
 - If the Test Lamp goes on, the short is in the wiring. You must find the short by disconnecting the circuit connectors, one at a time, until the Test Lamp goes out. For example, in Figure 5 with a ground at X, the bulb goes out when C1 or C2 is disconnected, but after disconnecting C3. This means the short is between C2 and C3.

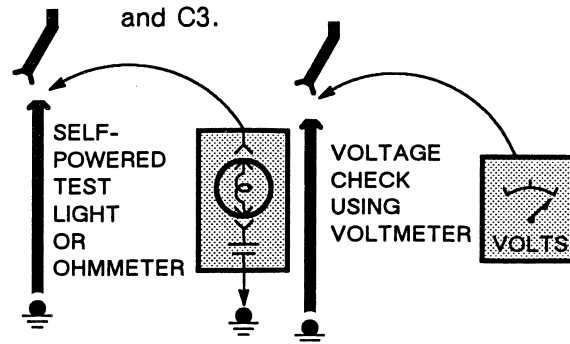

Figure 6—Ground Check

Turn on power to the circuit. Perform a Voltage Check between the suspected inoperative ground and the frame. Any indicated voltage means that the ground is inoperative (Figure 6).

Turn power to the circuit. Connect one lead of a Self-Powered Test Lamp or Ohmmeter to the wire in question and the other lead to a known ground. If the bulb glows, the circuit ground is OK (Figure 6).

TROUBLESHOOTING HINTS

The circuit schematics in this manual make it easy to identify common points in circuits. This knowledge can help narrow the concern to a specific area. For example, if several circuits fail at the same time, check for a common power or ground connection (see *Power Distribution* or *Grounds*). If part of a circuit fails, check the connections between the part that works and the part that doesn't work.

For example, if lo beam headlamps work, but high beams and the indicator lamp don't work, then power and ground paths must be good. Since the dimmer switch is the component that switches this power to the high beam lights and indicator, it is most likely the cause of failure.

Troubleshooting Hints unique to a particular circuit are given in a three column format. Included in the charts are conditions that may develop, possible causes, and one or more tests that can be done quickly to determine the cause of the condition.

2-5 HOW TO USE THIS MANUAL

HOW TO FIND THE VACUUM CONCERNS

These six steps present an orderly method of troubleshooting.

Step 1. Verify the concern.

- Operate the system and observe all symptoms to check the accuracy and completeness of the customer's complaint.

Step 2. Narrow the concern.

- Using the EVTm, narrow down the possible causes and locations of the concern to pinpoint the exact cause.

Step 3. Test the cause.

- Use test procedures to find the specific cause of the symptoms.

Step 4. Verify the cause.

- Confirm that you have found the right cause by operating the parts of the circuit you think are good.

Step 5. Make the repair.

- Repair or replace the inoperative component.

Step 6. Verify the repair.

- Operate the system as in Step 1. Check that your repair has removed all symptoms without creating any new symptoms.

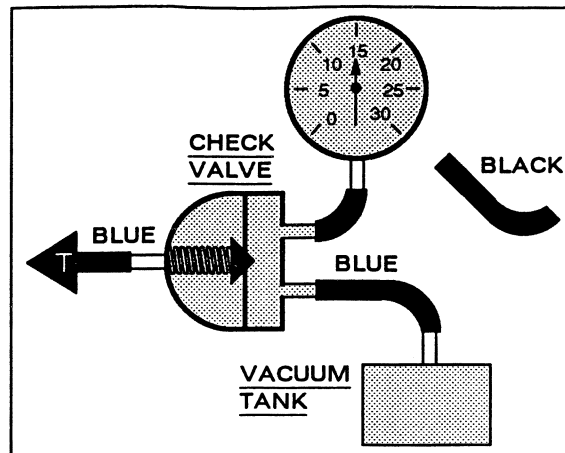

Figure 1 - System Supply Test

Vacuum Supply Test

1. Connect Vacuum Tester to system side of Check Valve (Figure 1).
2. Start engine. Gauge should show approximately 15 inches of vacuum.
3. Turn off engine, and observe gauge:
 - If vacuum holds, supply OK.
 - If vacuum fails, replace Check Valve or Tank.

Leak Test

1. Connect Vacuum Gauge and Vacuum Pump (Figure 2) to system hose in place of tank.
2. Open valve and start pump. Operate control in all modes.
3. Listen for hiss and observe gauge.

NOTE: Hissing is normal at Function Control when changing modes.

If system hisses or loses vacuum, find system leak as follows:

1. Turn on Vacuum Pump and check vacuum build-up.
2. Stop pump; vacuum should drop.
3. Clamp supply hoses with needlenose pliers, one at a time, until vacuum stops dropping (Figure 2).
4. Check vacuum schematic to find components in that line.
5. Clamp hoses through circuit to find leak.

Component Test

1. Connect Vacuum Tester to component.
2. Pump Vacuum Tester. Check that all components operate correctly and vacuum holds.
3. Replace component if vacuum does not hold.

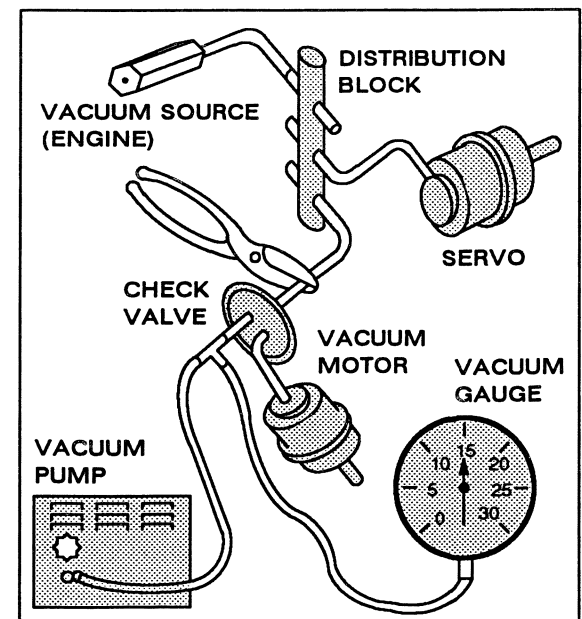

Figure 2 - Testing For Leaks In Typical Vacuum System

NOTE: Vacuum system problems fall into three groups.

100% SATISFACTION GUARANTEED

BUY IT NOW!

Click Here To Order

motor

m

PayPal American Express Cards Discover NOWUS MasterCard VISA

ELECTRICAL SYMBOLS

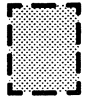

DASHED COMPONENT BOX
ONLY PART OF THE COMPONENT IS SHOWN ON THE PAGE; THE COMPONENT IS SHOWN COMPLETE IN ANOTHER LOCATION

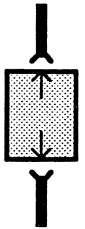

COMPONENT WITH CONNECTORS

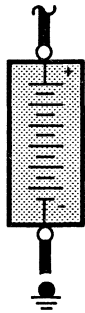

BATTERY

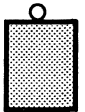

SCREW TERMINAL ON COMPONENT

SOLID STATE

SEALED ELECTRONIC COMPONENT
ANY CIRCUITRY SHOWN INSIDE THE

100% SATISFACTION GUARANTEED

BUY IT NOW!

Click Here To Order

CONNECTION

PayPal, American Express, Discover, MasterCard, VISA

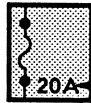

FUSE
CURRENT RATING

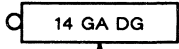

FUSIBLE LINK
WIRE SIZE AND COLOR



FUSIBLE LINK CARTRIDGE
CARTRIDGE CURRENT RATING

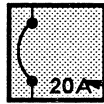

CIRCUIT BREAKER
CURRENT RATING

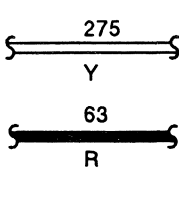

SOLID WIRES

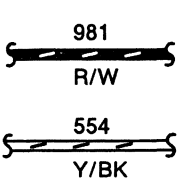

STRIPED WIRES

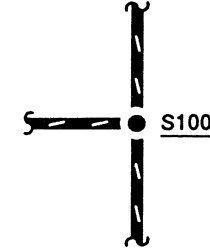

SPLICE OR CRIMP TERMINAL

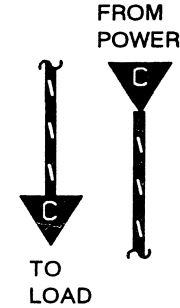

"CUT" WIRES REFERENCED BETWEEN PAGES
ARROWS SHOW CURRENT FLOW FROM POWER TO GROUND

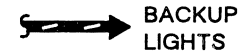

"REFERENCE" WIRES
COMPLETE WIRING SHOWN ON ANOTHER PAGE

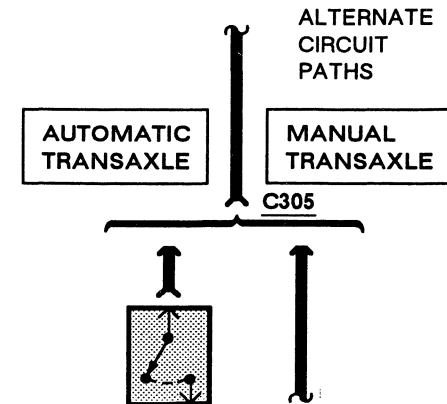

ALTERNATE CIRCUIT PATHS

2-7 HOW TO USE THIS MANUAL

ELECTRICAL SYMBOLS

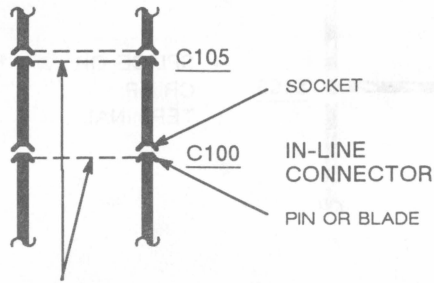

SINGLE OR DOUBLE DASHED LINE INDICATES THAT WIRE ON LEFT ALSO PASSES THROUGH THE SAME CONNECTOR

SEE GROUNDS
PAGES 10-1,
10-2

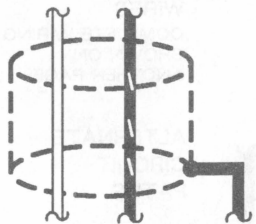
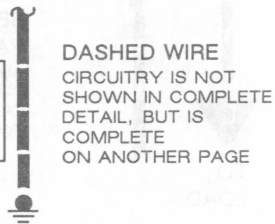

MOTOR



HEATING ELEMENT



THERMISTOR



RHEOSTAT OR POTENTIOMETER



SOLENOID



SWITCH

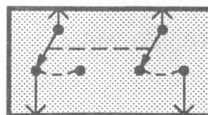

GANGED SWITCHES CONTACTS MOVE AT THE SAME TIME



DIODES CURRENT FLOWS IN DIRECTION OF ARROW ONLY



CAPACITOR



TRANSISTOR

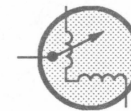

GAUGE



LIGHT BULB

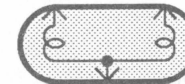

DUAL FILAMENT LIGHT BULB

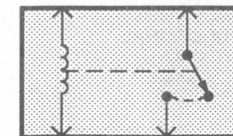

RELAY CONTACTS CHANGE POSITION WITH CURRENT THROUGH COIL

100% SATISFACTION GUARANTEED

BUY IT NOW!

Click Here To Order

PayPal American Express Discover MasterCard VISA

VACUUM SYMBOLS

"T" JUNCTION

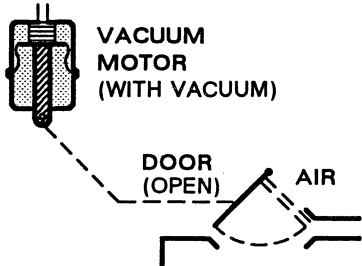

VACUUM ON VACUUM MOTOR PULLS DOOR OPEN TO LET AIR PASS THROUGH

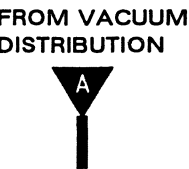
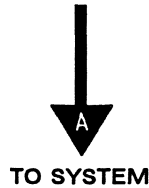

"CUT" HOSES REFERENCED BETWEEN PAGES
ARROW SHOWS FROM MANIFOLD FITTING TO COMPONENT

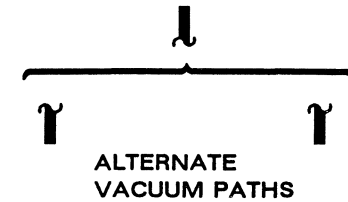

NOTE
Other vacuum symbols used on vacuum system diagrams are fully explained on those pages.

DOUBLE DIAPHRAGM MOTOR

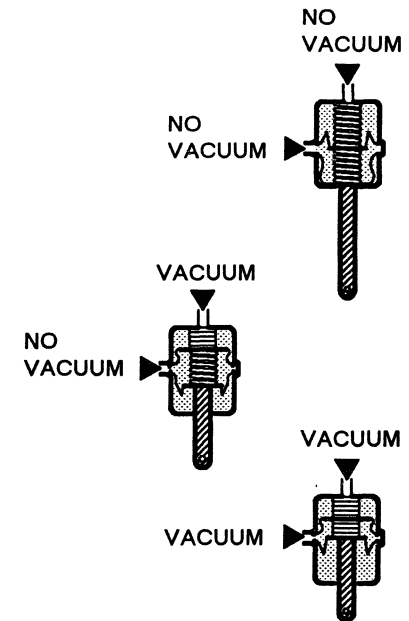

VACUUM MOTOR OPERATION

SINGLE DIAPHRAGM MOTOR

NO VACUUM



VACUUM



SERVO MOTOR

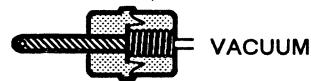

Some vacuum motors, such as the Servo Motor in the Speed Control, can position the actuating arm at any position between fully extended and fully retracted. The Servo is operated by a control valve that applies varying amounts of vacuum to the motor. The higher the vacuum level, the greater the retraction of the motor arm. Servo Motors work nearly the same way as two-position motors, except for the way the vacuum is applied. Servo Motors are generally larger and provide a calibrated control.

100% SATISFACTION GUARANTEED

BUY IT NOW!

Click Here To Order

A double diaphragm motor has three positions (it is actually two motors in one housing). When the top port gets vacuum, the shaft pulls halfway in. When both ports get vacuum, the shaft pulls all the way in.

7-1 TROUBLESHOOTING/DESCRIPTIONS

SECTION 10

GROUNDS

HOW THE CIRCUIT WORKS

The ground circuits show how many different systems may share a common ground point.

While all of the ground circuits shown are shown complete, additional ground circuits may exist in the vehicle. Any ground circuit not shown in Cell 10 is shown complete in the appropriate system schematic.

All wires are 57 (BK) unless otherwise noted.

SECTION 12

CHARGING SYSTEM

HOW THE CIRCUIT WORKS

The Alternator is belt-driven by the engine. Field current is supplied from the Integral Alternator Regulator (IAR), mounted on the rear of the Alternator, to the rotating field of the Alternator, through two brushes and two slip rings.

The Alternator produces power in the form of alternating current. The alternating current is rectified to direct current by six diodes. The Alternator Regulator automatically adjusts the Alternator field current to maintain the Alternator output voltage within prescribed limits to correctly charge the Battery. The Alternator is self-current limiting.

The regulator voltage control circuit is turned on when the Ignition Switch is in START or RUN and voltage is applied to Regulator terminal I through a resistor in parallel with the Charge Indicator. When the Ignition Switch is OFF, the control circuit is turned OFF and no field current flows to the Alternator.

The Charge Indicator is connected across the terminals of a 500-ohm resistor in the Instrument Cluster. Current passes through the Indicator when the Ignition Switch is in START or RUN and there is no voltage at terminal S. When voltage at terminal S rises to a preset value, the regulator switching circuits stop the

flow of current into terminal I and the indicator turns OFF.

System voltage is "sensed" at Regulator terminal A. The regulator switching circuits turn the warning indicator ON to indicate a system fault if terminal A voltage is excessively high or low or if the voltage at terminal S is below a preset value.

A Fuse Link is included in the charging system wiring on all models. The Fuse Link prevents damage to the wiring harness and Alternator if the wiring harness should become grounded or if a booster battery is improperly connected to the charging system.

TROUBLESHOOTING HINTS

CONDITION	POSSIBLE CAUSE	ACTION
<ul style="list-style-type: none"> Battery doesn't stay charged. 	<ul style="list-style-type: none"> Open or poor connections at Alternator output. 	<ul style="list-style-type: none"> Check that connectors or terminals on Alternator and Starter Relay are clean and tight. Check Fuse Links E and F.
	<ul style="list-style-type: none"> Loose Alternator drive belt. Corroded battery terminals. Inoperative Integral Alternator Regulator. 	<ul style="list-style-type: none"> Check Alternator belt tension. Check that battery post terminals are clean. Check that terminals cannot be easily turned by hand on battery posts. Check Alternator.

100% SATISFACTION GUARANTEED

BUY IT NOW!

Click Here To Order

PayPal American Express Discover MasterCard VISA

TROUBLESHOOTING/DESCRIPTIONS 7-2

SECTION 12 (cont'd)

For further diagnostic information, refer to Section 14 of the Shop Manual.

SECTION 13

POWER DISTRIBUTION

HOW THE CIRCUIT WORKS

The Power Distribution circuits show how several systems may receive power through the same fuse, circuit breaker or fuse link.

The circuits shown also indicate whether a particular fuse, circuit breaker or fuse link receives power directly from the Battery or through the Ignition Switch contacts.

For further diagnostic information, refer to Section 18-01 of the Shop Manual.

SECTION 20

STARTING SYSTEM

HOW THE CIRCUIT WORKS

The Battery, Starter Motor, Starter Relay and Ignition Switch make up the Starting System. On vehicles with automatic transmis-

sions, the Backup/Neutral Safety Switch must be closed (PARK or NEUTRAL) to operate the Starter Motor. On vehicles with manual transmissions, the Clutch Interrupt Switch must be closed (clutch fully depressed) to operate the Starter Motor.

Turning the Ignition Switch to START sends current through the Starter Relay coil and the relay operates. Current from the Battery then flows directly through the Starter Relay to the Starter Motor to start the engine.

TROUBLESHOOTING HINTS

CONDITION	POSSIBLE CAUSE	ACTION
<ul style="list-style-type: none">Starter cranks slowly or Starter relay chatters.	<ul style="list-style-type: none">Low charge in Battery.	<ul style="list-style-type: none">Perform battery load test.



BUY IT NOW!
Click Here To Order



7-3 TROUBLESHOOTING/DESCRIPTIONS

SECTION 20 (cont'd)

TROUBLESHOOTING HINTS

CONDITION	POSSIBLE CAUSE	ACTION
<ul style="list-style-type: none"> Starter Relay clicks, but starter doesn't crank. 	<ul style="list-style-type: none"> Corroded terminals on Battery Starter Relay or Starter Motor. 	<ul style="list-style-type: none"> Check that terminals are clean at battery post, Starter Relay, engine ground and Starter Motor. Make sure cable terminals are tight by checking that terminals cannot be easily turned by hand. Disconnect 11 (T/Y) wire from Ignition Coil (5.0L) and measure voltage between negative battery terminals and ground while Ignition Switch is in START. If voltage is greater than 0.5 volts, check negative battery terminal and engine ground for corroded connections, or check cable to engine ground. Measure voltage between positive battery terminal and main (battery) terminal of Starter Relay while Ignition Switch is in START. If voltage is greater than 0.5 volts, check positive battery terminal and main relay terminal for corroded connection, or check R wire. Measure voltage between BK wire at Starter Relay and BK wire at Starter Motor while Ignition Switch is in START. If voltage is greater than 0.5 volts, check terminals for corroded connections, or check BK wire.
<ul style="list-style-type: none"> Starter Relay doesn't click. 	<ul style="list-style-type: none"> Inoperative Ignition Switch. Inoperative Starter Relay. Starter Relay not grounded. 	<ul style="list-style-type: none"> Remove 32 (R/LB) wire from Starter Relay. With transaxle in PARK or NEUTRAL and the car on the lift, jumper this terminal to the main (battery) terminal of the Starter Relay. If starter operates, check Ignition Switch and Start Circuit. If Starter Relay doesn't operate, check it for proper operation. Check that Starter Relay bracket is grounded tightly. Repeat action above.
<ul style="list-style-type: none"> Starter spins (humming noise) but doesn't crank engine. 	<ul style="list-style-type: none"> Inoperative starter drive. 	<ul style="list-style-type: none"> Remove Starter Motor and check/repair/replace starter drive.

For further diagnostic information, refer to Section 03-06 of the Shop Manual.

100% SATISFACTION GUARANTEED

BUY IT NOW!

Click Here To Order

SECTION 21

IGNITION SYSTEM

TFI IGNITION (5.0L)

The Ignition System contains a Thick Film Integrated (TFI) Ignition Module, which is mounted on the side of the Distributor.

When the engine is cranking or running:

- The pickup in the Distributor provides the signal input through the TFI Ignition Module to the Electronic Engine Control (EEC) Module, which returns a signal to the TFI Ignition Module. The TFI Ignition Module switches current on and off in the primary circuit of the ignition coil, according to the signal from the Electronic Engine Control (EEC) Module.
- Each interruption of primary current makes the Ignition Coil secondary circuit produce an open circuit high-voltage pulse of up to 40,000 volts.

High-voltage pulses are transmitted to the Distributor, which sends them to fire the spark plugs.

Two signal circuits, 395 (GY/O) and 929 (PK), are connected between the TFI Ignition Module and the Electronic Engine Control (EEC) Module.

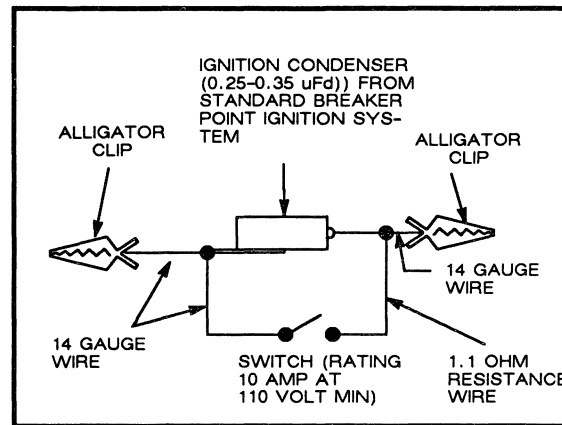

Make up a test jumper as shown in figure 1. It is important to use only this test jumper when making these checks. Solid wire jumpers will not work for the quick checks.

CAUTION

Do not leave test jumper closed for more than one second at a time.

TROUBLESHOOTING HINTS (5.0L)

CONDITION	POSSIBLE CAUSE	ACTION
<ul style="list-style-type: none"> Starter cranks engine, but engine doesn't start. 	<ul style="list-style-type: none"> No voltage at TFI Ignition Module or Distributor. Inoperative TFI Ignition Module. 	<ul style="list-style-type: none"> Check that TFI Ignition Module is securely attached to Distributor. Check for loose or damaged spark plug wires or coil wires. If any boots or nipples are removed, reapply new silicone dielectric compound. Make sure all ignition wires are connected correctly. VOLTAGE TEST <p>Disconnect connector at TFI Ignition Module. Check for battery voltage between each pin (+) and ground (-) as follows (use a straight pin in connector socket hole to make contact):</p> <ol style="list-style-type: none"> With Ignition Switch in OFF position, check for 0 volts at each terminal. <ul style="list-style-type: none"> If voltage is present, check Ignition Switch.

100% SATISFACTION GUARANTEED

BUY IT NOW!

Click Here To Order

7-5 TROUBLESHOOTING/DESCRIPTIONS

SECTION 21 (cont'd)

TROUBLESHOOTING HINTS (5.0L)

CONDITION	POSSIBLE CAUSE	ACTION
<ul style="list-style-type: none"> Starter cranks engine, but engine doesn't start. 	<ul style="list-style-type: none"> No voltage at TFI Ignition Module or Distributor. Inoperative TFI Ignition Module. 	<ol style="list-style-type: none"> Turn Ignition Switch to RUN. Check for battery voltage at 16 (R/LG) and 11 (T/Y) wires. Check for 0 volts at 32 (R/LB) wire. <ul style="list-style-type: none"> If voltage is present, check Ignition Switch. Disconnect 32 (R/LB) wire plug at Starter Relay. Turn Ignition switch to START. Check for battery voltage at all three wires. <ul style="list-style-type: none"> Check continuity of Ignition Switch and 32 (R/LB) wire if inoperative. Reconnect 32 (R/LB) wire at Starter Relay. <ul style="list-style-type: none"> RUN-MODE SPARK TEST <ol style="list-style-type: none"> Remove coil wire from Distributor cap. Install spark tester in coil wire terminal. Unplug connector at TFI Ignition Module. In the harness side of the connector, connect the special test jumper (figure 1) between ground and the 11 (T/Y) lead. Use a straight pin in connector socket hole to make contact. With the Ignition Switch in RUN, close the test jumper switch. Leave closed for about one second, then open. Repeat this several times. There should be a spark each time this switch is opened. <ul style="list-style-type: none"> If there is no spark, the problem is in the primary circuit. Check coil for internal shorts or opens. Check primary resistance (0.5 ohm) and secondary resistance (8000 to 11,500 ohms). If the coil is good and there is no spark, check TFI Ignition Module.

HOW THE CIRCUIT WORKS

Interless Ignition System (2.3L)

100% SATISFACTION GUARANTEED

BUY IT NOW!

Click Here To Order

em (DIS),
on is han-
parts. This
replace-
y timed
IV Mod-

ule determines the ignition timing required by the engine, and a DIS Module determines which ignition coil to fire.

The Crankshaft Position Sensor is a dual Hall-effect magnetic switch actuated by the dual vane cup on the crankshaft pulley hub assembly. This sensor generates two separate signals, PIP (profile ignition pick-up) and CID

(cylinder identification).

The PIP signal provides base timing and RPM information, while the CID signal is used to synchronize the ignition coils. Initial timing (base timing) is set at 10 degrees BTDC and is not adjustable.

SECTION 21 (cont'd)

Two ignition coil packs are used for the 2.3L dual spark plug engine. The two ignition coil packs are triggered by the DIS Module and are timed by the EEC IV Module. Each coil pack contains two separate ignition coils for a total of four ignition coils. Each ignition coil fires two spark plugs simultaneously, one spark plug on the compression stroke and one on the exhaust stroke. The spark plug fired on the exhaust stroke uses very little of the ignition coil's stored energy; the majority of the ignition coil's energy is used by the spark plug on the compression stroke. Since these two spark plugs are connected in series, the firing voltage of one spark plug will be negative with respect to ground, while the other will be positive with respect to ground.

The main function of the DIS Module is to switch between ignition coils and to trigger the coils to spark. The DIS Module receives the PIP and CID signals from the Crankshaft Position Sensor, and the SPOUT (spark out) signal from

the EEC IV Module. During normal operation, PIP is passed on to the EEC IV Module and provides base timing and RPM information. The CID signal provides the DIS Module with the information required to switch between the coils for cylinders 1 and 4 and the coils for cylinders 2 and 3. The SPOUT signal (from the EEC IV Module) contains the optimum spark timing and dwell time information. The dwell time is controlled or varied by varying the duty cycle (duration) of the SPOUT signal. This feature is called CCD (computer controlled dwell). Therefore, with the proper inputs of PIP, CID and SPOUT, the DIS Ignition Module turns the ignition coils on and off in the proper sequence for spark control.

During some DIS faults, the failure-mode effects-management (FMEM) portion of the DIS Module will maintain vehicle operation. If the DIS Module does not receive the SPOUT input, it will automatically turn the ignition coils on and off using the PIP signal. However, this

will result in fixed spark timing (ten degrees BTDC) and a fixed dwell time (no CCD). If the DIS Module does not receive the CID input, random coil synchronization will be attempted by the module. Therefore, several start attempts may be required to start the engine.

Dual Plug Inhibit (DPI) is a function of EEC IV that is used when the vehicle is being started. During engine cranking the EEC IV Module will only fire the spark plugs on the right hand side of the engine. When the engine has started, the EEC IV Module will send a signal to the DIS module to start normal dual plug operation.

Ignition Diagnostic Monitor

The Ignition Diagnostic Monitor (IDM) is a function of the DIS Module. The DIS Module sends information on system failures to the EEC IV Module, which stores the information for diagnostic self test. The IDM signal also is used to drive the vehicle instrument tachometer and test tachometer for system diagnosis.

TROUBLESHOOTING HINTS (2.3L)

CONDITION	POSSIBLE CAUSE	ACTION
<ul style="list-style-type: none"> No spark at spark plugs. 	<ul style="list-style-type: none"> Problem is primary circuit from the Ignition Switch through the Ignition Coil and Ignition Module to ground. Inoperative Distributorless Ignition System (DIS) Module. Problem in the EEC system. 	<ul style="list-style-type: none"> Check Battery for state of charge and for clean, tight battery terminal connections. Inspect all wires and connectors for breaks, cuts, abrasions or burned spots. Check/Repair as necessary. Make sure all wires are connected correctly. Unplug all connectors and inspect for corroded or burned contacts. Repair as necessary and plug connectors back together. Do NOT remove grease in connectors. Check for loose or damaged spark plug or coil wires. If boots or nipples are removed on 8mm ignition wires, re-line inside of each with new silicone dielectric compound. Refer to Powertrain Control/Emissions Diagnosis Manual.

100% SATISFACTION GUARANTEED

BUY IT NOW!

Click Here To Order

PayPal American Express Discover MasterCard VISA

7-7 TROUBLESHOOTING/DESCRIPTIONS

SECTION 21 (cont'd)

For further diagnostic information, refer to the Powertrain Control/Emissions Diagnosis Manual.

SECTION 23

ELECTRONIC ENGINE CONTROL (2.3 EFI)

HOW THE CIRCUIT WORKS

The Electronic Engine Control System (EEC IV) includes an Electronic Engine Control (EEC) Module that receives inputs from various sensors. The EEC Module uses this information to control Fuel Flow, Exhaust Gas Recirculation (EGR) and Ignition. These three systems and the EEC Module work together to provide improved fuel economy and performance and lower exhaust emissions.

Fuel Flow

The 2.3L Electronic Fuel Injection System (EFI) is classified as a multi-point, pulse time, fuel injection system. A metered amount of fuel is injected into each cylinder in accordance with engine demand. The EEC Module determines the required fuel flow rate from various engine sensors.

The Fuel Pump supplies fuel under pressure to the Fuel Injectors. When the Ignition Switch is turned to RUN or START, voltage is applied to the Fuel Pump. The Fuel Control Module and the Inertia Switch are connected to the Fuel Pump. When the Inertia Switch is turned off, the voltage to the Fuel Pump is removed. When the Inertia Switch is turned on, the voltage is applied to the Fuel Pump. When the Inertia Switch is turned off, the voltage to the Fuel Pump is removed. When the Inertia Switch is turned on, the voltage is applied to the Fuel Pump.

NOTE: If the engine does not operate after a collision, it may be that the Inertia Switch has opened. To reset the switch, put your finger through the hole in front of the trunk trim line and push down on the plunger.

WARNING

If you see or smell gasoline, do not reset the Inertia Switch.

Exhaust Gas Recirculation (EGR)

The EGR Vacuum Regulator controls the EGR valve movement. The EEC Module receives data from various sensors and also checks the existing valve position through the EGR Valve Position Sensor. The EEC Module calculates if the present EGR flow should be increased, maintained or decreased, and determines how to operate the EGR Valve to control emissions.

Canister Purge

The carbon canister collects fuel vapors from the fuel tank to be burned later in the engine. The Canister Purge Solenoid is controlled by the EEC Module. When the EEC Module grounds the Canister Purge Solenoid, the vapors are released to the engine for burning.

Ignition

The EEC System has a special Distributorless Ignition System (DIS) that has no centrifugal or vacuum advance mechanisms. Instead, all ignition timing is controlled by the EEC Module.

Electronic Engine Control (EEC) Module Inputs

The Electronic Engine Control (EEC) Module uses information from various sensors to determine engine operating conditions.

Mass Air Flow (MAF) Sensor

The Mass Air Flow (MAF) Sensor directly measures the mass of the air flowing into the engine. The sensor output is used by the EEC Module to calculate the injector pulse width for proper air/fuel ratio.

A4LD Transmission (If Equipped)

The A4LD Transmission is a 4-speed automatic overdrive transmission with a lock-up torque converter. This is controlled by the EEC Module. Two functions incorporated in the A4LD Transmission for times when acceleration or more power is needed are: (1) disengagement of the converter clutch to achieve added acceleration from the resultant increase in engine speed, and (2) a part throttle 4-3 (OD



SECTION 23 (cont'd)

to direct drive) downshift for further acceleration.

Idle Air Bypass Valve

The Idle Air Bypass Valve controls engine idle speed by regulating the amount of air allowed to pass around the throttle plates. This permits the EEC Module to make idle speed corrections to prevent engine stall during cold engine warm-ups as engine load changes.

Barometric Absolute Pressure (BAP)

The Barometric Absolute Pressure (BAP) Sensor measures the barometric pressure and provides this information as a variable frequency signal to the EEC Module.

Throttle Position Sensor

The Throttle Position Sensor is a potentiometer. The sensor output is a DC voltage that varies with throttle plate angle. By monitoring the Throttle Position Sensor output, the EEC Module calculates fuel delivery requirements based on driver demand.

Heated Exhaust Gas Oxygen (HEGO) Sensor

The Heated Exhaust Gas Oxygen (HEGO) Sensor provides a voltage for regulating the air/fuel ratio to the EEC Module by sensing the oxygen content of the exhaust gases. Too much oxygen indicates a lean mixture, while too little oxygen indicates a rich mixture.

Power Steering Pressure Switch

The Power Steering Pressure Switch is used to indicate increased engine load to the EEC Module. The switch will signal increased engine load to the EEC Module when power steering fluid pressure increases (when the steering is turned from lock to lock). The EEC Module will then increase engine idle speed to prevent engine stall.

Engine Coolant Temperature (ECT) Sensor

The Engine Coolant Temperature (ECT) Sensor is a thermistor whose resistance decreases as engine coolant temperature increases and increases as engine coolant temperature decreases (Negative Temperature Coefficient). The EEC Module measures the voltage drop across the Engine Coolant Tem-

perature (ECT) Sensor and uses this information to calculate fuel delivery, spark timing and EGR control.

Air Charge Temperature (ACT) Sensor

The Air Charge Temperature (ACT) Sensor is a thermistor whose resistance decreases as manifold air temperature increases and increases as manifold air temperature decreases (Negative Temperature Coefficient). The EEC Module measures the voltage drop across the Air Charge Temperature (ACT) Sensor and uses this information to calculate fuel delivery, spark timing and EGR control.

Vehicle Speed Sensor (VSS)

The Vehicle Speed Sensor (VSS) generates an AC signal that is proportional to vehicle speed. The AC signal is sent to the EEC Module and is used for engine management.

Integrated Relay Control Module

The Integrated Relay Control Module supplies power to the A/C Clutch, Electric Cooling Fan, Fuel Pump and EEC Module. Their functions are integrated into the module.

For further diagnostic information, refer to the Powertrain Control/Emissions Diagnosis Manual.

SECTION 24

The Electronic Engine Control System uses an Electronic Engine Control (EEC) Module to control fuel flow, exhaust gas recirculation (EGR), ignition system functions, evaporative

emission, idle speed, A/C cutout, engine cooling and air management.



7-9 TROUBLESHOOTING/DESCRIPTIONS

SECTION 24 (cont'd)

Fuel Flow

Fuel injectors, mounted in the intake manifold at the intake port, meter the flow of fuel into the engine. The EEC Module fires the injectors.

Fuel is supplied to the engine by an in-tank Electric Fuel Pump. When the Ignition Switch is turned to the RUN position, voltage is applied to the Fuel Pump Relay Coil. The Coil is grounded by the EEC Module and the relay contacts close. Voltage is now applied to the Fuel Pump.

When the Fuel Pump Relay is grounded by the EEC Module and the Inertia Switch is closed, power is supplied to the Fuel Pump. Fuel flow is produced by the Fuel Pump, and fuel pressure is built up in the fuel delivery system. Fuel Pressure is controlled by a fuel pressure regulator.

NOTE: If the engine does not operate after a collision, it may be that the Inertia Switch has opened. To reset the switch, put your finger through the hole in front of the trunk trim line and push down on the plunger.

WARNING

If you see or smell gasoline, do not reset the Inertia Switch.



100% SATISFACTION GUARANTEED

BUY IT NOW!

Click Here To Order

PayPal American Express Discover MasterCard VISA

through the spark output (SPOUT) signal (circuit 929). The SPOUT signal informs the TFI Ignition Module when to collapse the ground on the primary circuit to allow the secondary circuit to fire the spark plugs.

Idle Air Bypass Valve

The Idle Air Bypass Valve controls engine idle speed by regulating the amount of air allowed to pass around the throttle plates. This permits the EEC Module to make idle speed corrections to prevent engine stall during cold engine warm ups as an engine load changes.

Exhaust Gas Recirculation (EGR)

The EGR System cools down the combustion chambers in the engine to reduce the oxides of nitrogen emitted to the atmosphere. The EEC Module controls the EGR Vacuum Regulator Solenoid, which is normally closed.

When the Solenoid is energized, vacuum flows through the solenoid valve to the EGR valve. With vacuum applied to the EGR valve, the pintle opens and exhaust gas recirculates from the exhaust system back into the intake manifold.

The EGR Valve Position Sensor indicates valve position to the EEC Module by providing a voltage signal proportional to the EGR valve position. The EEC Module determines correct EGR valve position depending on engine operating conditions.

Canister Purge

The carbon canister collects fuel vapors from the fuel tank and stores them to be burned later in the engine. The EEC Module controls the Canister Purge Solenoid and grounds the solenoid, releasing fuel vapors to be burned in the engine.

Thermactor Air Injection System

The Thermactor Air Injection System reduces the hydrocarbon and carbon monoxide content of the engine's exhaust gases. The system accomplishes this by pumping fresh air into the exhaust system, when necessary. The fresh air mixes with the hot exhaust gases, causing unburned fuel to burn.

Thermactor Air can be injected into the exhaust manifolds, into the catalytic converter or vented to the atmosphere, depending on engine conditions sensed by the EEC Module.

During engine warm up, both the Thermactor Air Diverter Solenoid and the Thermactor Air Bypass Solenoid are energized. With both Solenoids energized, fresh air is pumped into the exhaust manifolds and unburned fuel burns in the exhaust pipes leading to the catalytic converter. This causes the converter to warm up quickly.

After the engine warms up, the Thermactor Air Diverter Solenoid is deenergized. With the Thermactor Air Bypass Solenoid energized and the Diverter Solenoid deenergized, fresh air is pumped into the catalytic converter.

Under some conditions both Solenoids are deenergized and air is not injected into the exhaust system. Instead, it is vented to the atmosphere.

Electronic Engine Control (EEC) Module Inputs

Various input devices determine engine operating conditions. The following inputs signal the EEC Module with specific information:

TROUBLESHOOTING/DESCRIPTIONS 7-10

SECTION 24 (cont'd)

The Throttle Position Sensor is a potentiometer. The Sensor output is a DC voltage that varies with throttle plate angle. By monitoring the Throttle Position Sensor output, the EEC Module calculates fuel delivery requirements based on driver demand.

The Barometric Absolute Pressure (BAP) Sensor signals barometric pressure conditions (changes in altitude) with ignition key on and engine off, and updates this information during wide-open throttle conditions.

The A/C Signal is received from the A/C system and informs the EEC Module when the A/C clutch has been turned on. During periods

of wide-open throttle acceleration, the A/C signal informs the EEC Module that the A/C Compressor must be turned off.

The Air Charge Temperature (ACT) Sensor is a thermistor in which resistance decreases as manifold air temperature increases (Negative Temperature Coefficient or NTC). The EEC Module detects the voltage drop across the Air Charge Temperature (ACT) Sensor and uses this information to help calculate fuel delivery.

The Mass Air Flow (MAF) Sensor measures the amount of air flowing into the intake manifold. The Mass Air Flow (MAF) Sensor uses a thermistor to measure air temperature. The

EEC Module detects the voltage drop across the thermistor as air passes around it and uses this information to calculate fuel delivery, spark timing and EGR control.

The Engine Coolant Temperature (ECT) Sensor is a thermistor in which resistance decreases as engine coolant temperature decreases.

The EEC Module detects the voltage drop across the Engine Coolant Temperature (ECT) Sensor and uses this information to help calculate fuel delivery, spark timing and EGR control.

For further diagnostic information, refer to the Powertrain Control/Emissions Diagnosis Manual.

SECTION 31

SPEED CONTROL

HOW THE CIRCUIT WORKS

The Speed Control Amplifier controls vacuum to the Speed Control Servo Motor through the Modulating Valve. The Servo Motor moves the throttle through the Actuator cable.

To operate the Speed Control System, the engine must be running and vehicle speed must be greater than 30 mph. The system is activated by depressing the ON/OFF Switch.

present speed. This speed becomes the set speed. The Vehicle Speed Sensor sends signals to the Speed Control Amplifier. These signals tell the amplifier to increase or decrease the vacuum at the Servo Motor to keep the vehicle at the set speed.

Pressing and holding SET/ACCEL speeds up the car. The vehicle's speed increases as long as SET/ACCEL is depressed. Releasing SET/ACCEL gives the system a new set speed to maintain. Vehicle speed can also be increased by depressing the accelerator until the higher speed is reached, then depressing and releasing SET/ACCEL.

Pressing and holding COAST slows down the vehicle. The vehicle speed decreases as long as COAST is depressed. Releasing COAST gives the system a new set speed to maintain.

Pressing OFF turns off the system (grounds 151 [LB/BK] wire). The system is also turned off when the brake pedal is depressed (power through 810 [R/LG] wire) or the Ignition Switch is turned OFF. The Vacuum Dump Valve also operates when the brake pedal is depressed. This is a backup device to release the servo.

7-11 TROUBLESHOOTING/DESCRIPTIONS

SECTION 31 (cont'd)

In vehicles with manual transmission, the Speed Control Amplifier monitors a ground reference input through the Clutch Switch, the 810 (R/LG) wire and the Stop Lamp bulbs. When the clutch pedal is depressed, the

ground circuit is open and the Speed Control System turns off.

When the system has been deactivated by depressing the brake or clutch pedal, the last

set speed may be resumed by pressing RESUME. This feature will not work if OFF has been depressed or if car speed drops below 30 mph.

TROUBLESHOOTING HINTS

CONDITION	POSSIBLE CAUSE	ACTION
<ul style="list-style-type: none"> System doesn't operate. 	<ul style="list-style-type: none"> Open circuit to Speed Control Switch. 	<ul style="list-style-type: none"> Disconnect Speed Control Amplifier connector and measure the resistance between the 151 (LB/BK) and 57 (BK) wires while pressing the switches indicated. Rotate steering wheel through its full range and check that resistance remains within the range given. Depress OFF: less than 1 ohm Depress SET/ACCEL: 646 to 714 ohms Depress COAST: 114 to 126 ohms Depress RESUME: 2090 to 2310 ohms. If resistance fluctuates while steering wheel is rotated, remove steering wheel and check Clockspring Assembly. If resistances are out of the ranges shown, refer to Section 37 of the Shop Manual.
<ul style="list-style-type: none"> System operates, but is erratic or unstable. 	<ul style="list-style-type: none"> Throttle linkage is binding or loose. 	<ul style="list-style-type: none"> Check that Speed Control Servo and throttle linkage are not binding. Check that Actuator cable has as much tension as possible without holding throttle open.
<ul style="list-style-type: none"> System doesn't operate. 	<ul style="list-style-type: none"> Open Modulating Valve. 	<ul style="list-style-type: none"> Disconnect Speed Control Amplifier connector C214 and measure the resistance between the following wires: 144 (O/Y) and 145 (GY/BK): 40 to 75 ohms. 144 (O/Y) and 146 (W/PK): 100 to 150 ohms. If resistances aren't in the ranges shown, check the Modulating Valve.



BUY IT NOW!
Click Here To Order



TROUBLESHOOTING/DESCRIPTIONS 7-12

SECTION 31 (cont'd)

For further diagnostic information, refer to Section 10-03 of the Shop Manual.

SECTION 33

COOLING FANS

HOW THE CIRCUIT WORKS

The Cooling Fan System consists of a one-speed fan and an electric motor. The Electric

Cooling Fan operates only when the Ignition Switch is in RUN.

The Integrated Control Module and the Electronic Engine Control (EEC) Module control the Electric Cooling Fan.

The Electric Cooling Fan turns on when the engine temperature is higher than normal (on at 102°C, off at 99°C), or A/C is on and vehicle speed does not provide enough airflow (on at 52 mph or below, off at 45 mph).

TROUBLESHOOTING HINTS

CONDITION	POSSIBLE CAUSE	ACTION
<ul style="list-style-type: none">Electric Cooling Fan doesn't operate at any speed.	<ul style="list-style-type: none">No power to Integrated Control Module.Inoperative Electric Cooling Fan Motor ground.Inoperative Electric Cooling Fan Motor.Inoperative Integrated Control Module.	<ul style="list-style-type: none">Visually inspect Fuse Links G, J and H.Check for battery voltage at all 38 (BK/O), 37 (Y) and 787 (PK/BK) terminals of the Integrated Control Module.Check continuity of 57 (BK) wire from Electric Cooling Fan Motor to ground.If all wires are OK, unplug 228 (DB) wire from Electric Cooling Fan Motor and use a fused jumper to apply battery voltage directly to the terminal of the Electric Cooling Fan Motor. It should operate at HI speed. If it doesn't, check Electric Cooling Fan Motor.If the Electric Cooling Fan Motor works, refer to Powertrain Control/Emissions Diagnosis Manual for diagnosis of Integrated Control Module.

For further diagnostic information, refer to Section 03-03 of the Shop Manual.

100% SATISFACTION GUARANTEED

BUY IT NOW!

Click Here To Order

PayPal American Express Discover MasterCard VISA

7-13 TROUBLESHOOTING/DESCRIPTIONS

SECTION 37

SHIFT LOCK

HOW THE CIRCUIT WORKS

With the Ignition Switch in RUN, the Shift Lock Actuator prevents the driver from shifting the automatic transmission out of PARK unless the brake pedal is depressed.

NOTE: If the gear selector cannot be shifted out of Park with the Ignition Switch in RUN and the brake pedal depressed, follow these steps:

- Turn Ignition Switch to OFF
- Move shift lever to NEUTRAL
- Start the engine
- Shift into DRIVE

TROUBLESHOOTING HINTS

CONDITION	POSSIBLE CAUSE	ACTION
<ul style="list-style-type: none">• Transmission can be shifted out of PARK when Ignition Switch is in RUN and brake pedal is not depressed.	<ul style="list-style-type: none">• No power to Shift Lock Actuator.• Open Ground circuit.• Inoperative Shift Lock Actuator or cable assembly.	<ul style="list-style-type: none">• Check Fuse 5.• Check continuity of 57 (BK) wire between Shift Lock Actuator and G200.• With the Shift Lock Actuator energized, cable at shifter should have no play; with Shift Lock Actuator deenergized, cable at shifter should have free play.
<ul style="list-style-type: none">• Transmission cannot be shifted out of PARK when Ignition Switch is in RUN and brake pedal is depressed.	<ul style="list-style-type: none">• Inoperative Stop Lamp Switch.• Inoperative Shift Lock Actuator or cable assembly.	<ul style="list-style-type: none">• Connect a jumper wire across the Stop Lamp Switch with the Ignition Switch in RUN. If actuator unlocks, check Stop Lamp Switch. If actuator remains locked, check continuity of 810 (R/LG) wire from Stop Lamp Switch to Shift Lock Actuator.• With Shift Lock Actuator energized, cable at shifter should have no play; with Shift Lock Actuator deenergized, cable at shifter should have free play.

For further diagnostic information, refer to Section 17-02 of the Shop Manual.



BUY IT NOW!
Click Here To Order



TROUBLESHOOTING/DESCRIPTIONS 7-14

SECTION 44

HORN/CIGAR LIGHTER

HOW THE CIRCUIT WORKS

Horn

A Horn Switch is mounted in each of the upper steering wheel spokes. With a Horn Switch depressed, the Horn Relay is energized and

current flows from Fuse 16 through the Horn Relay contacts to the Low and High Pitch Horns. The horns sound.

Cigar Lighter

Voltage is applied, at all times, through Fuse 16 to the Cigar Lighter. When the Cigar

Lighter is depressed, the contacts close and current flows through the heating element to ground.

TROUBLESHOOTING HINTS

CONDITION	POSSIBLE CAUSE	ACTION
<ul style="list-style-type: none"> Horn doesn't work. 	<ul style="list-style-type: none"> No voltage at Horn Relay. 	<ul style="list-style-type: none"> Check Fuse 16. Remove Fuse 16 and connect meter across Fuse 16 position. If meter reads BATTERY when Horn Switch is pushed, switch is good. Attach a jumper between the Battery and Horn connector and another jumper between the Horn bracket and ground. (Do this step for both Left and Right Horns. If Horn doesn't sound, check Horn.) Check for battery voltage at the Horn Relay connector 40 (LB/W) wire. Unplug the Horn Relay and connect a fused jumper from 40 (LB/W) to 1 (DB) wire. If horn sounds, check Horn Relay and Horn Relay ground.
<ul style="list-style-type: none"> Horn doesn't turn off. 	<ul style="list-style-type: none"> Short in circuit. Sticking Horn Relay contacts. 	<ul style="list-style-type: none"> Disconnect connector C2018 from Steering Wheel Control Switch. If Horn shuts off, check Switch Assembly. If Horn continues to sound, check Horn Relay. Without speed control, remove Fuse 16 and perform continuity check of Horn Switch (not depressed). If continuity is present, check Horn Switch. Unplug Horn Relay and check for short between terminals 4 and 3.
<ul style="list-style-type: none"> Cigar Lighter doesn't work. 	<ul style="list-style-type: none"> No voltage at lighter. 	<ul style="list-style-type: none"> Check Fuse 16. Check for voltage at the Cigar Lighter 40 (LB/W) circuit. Check for continuity to ground at the lighter shell.



BUY IT NOW!
Click Here To Order



7-15 TROUBLESHOOTING/DESCRIPTIONS

SECTION 44 (cont'd)

For further diagnostic information, refer to Sections 13-06 and 13-07 of the Shop Manual.

SECTION 46

AIR BAG RESTRAINT SYSTEM HOW THE CIRCUIT WORKS

The Air Bag Restraint System consists of a driver air bag, an Air Bag Diagnostic Module and Crash Sensors.

Air Bag Diagnostic Module

The Air Bag Diagnostic Module contains a microcomputer that monitors electrical system components and connections. The assembly performs a self-check of the microcomputer's internal circuits and energizes the Air Bag Indicator lamp during prove out and whenever a fault occurs. Eleven different faults can be detected and translated into a coded lamp display. If certain faults occur, the system will be

disarmed by a firing disarm device built into the Diagnostic Module. If a system fault exists and the lamp is malfunctioning, an audible tone will be heard, indicating the need for service.

Sensors

The Sensor assembly is an electrical switch that reacts to impacts according to direction and force. It discriminates between impacts that require air bag inflation and impacts that do not require air bag inflation. When an impact occurs that requires air bag inflation, the sensor contacts close, completing the electrical circuit: the system then operates.

Four crash sensors are mounted in the vehicle. At least two sensors, one safing, one

forward, must be activated to inflate the air bag.

Warning

Do not attempt to diagnose or troubleshoot air bag circuitry without consulting the shop manual. Improper troubleshooting could cause the air bag to fire inadvertently, causing injury.

For further diagnostic information, refer to Section 01-20 of the Shop Manual.

SECTION 53

HEATER



100% SATISFACTION GUARANTEED

BUY IT NOW!

Click Here To Order

air system
lower in-

PayPal American Express Cards Discover NOW! MasterCard VISA

let, which is connected directly to an opening in the upper cowl. Outside air is drawn into the system from the cowl, through the blower inlet, into the blower housing. It is forced through and/or around the heater core, mixed, and then discharged through outlets in the discharged air duct to the floor area or through

the defroster outlets and/or instrument panel registers, depending upon the type of climate control desired. Several doors determine the amount of air that goes through the heater core and the particular outlet(s) through which it discharges.

Off

When the Heater Function Selector Switch is in the OFF position:

- The outside-recirc door is at full vacuum. As a result, outside air is closed off and inside air is admitted to the system.
- The panel/defrost door and the floor/panel door are both at full vacuum, closing off the passages to the defrosters.
- The blend door position may be anywhere within the range of its cable travel from FULL HEAT to FULL COLD.
- The Blower Motor is off.

Vent

When the Heater Function Selector Switch is in the VENT position:

- The outside-recirc door, with no vacuum being applied, will block recirc air and admit outside air.
- The floor/panel door is at “no vacuum” to block airflow to the floor registers, and the panel/defrost door is at full vacuum, closing off airflow to the defrosters and airflow is directed through the system to the instrument panel registers.
- The temperature selector may be adjusted to heat the air, if desired.
- The Blower Motor is on.

Floor

When the Heater Function Selector Switch is in the FLOOR position:

- The outside-recirc door is in the “no vacuum” position to block recirc air and admit outside air.
- The panel/defrost door is in the “no vacuum” position to block air circulation to the panel registers.
- The floor/panel door is in the full vacuum position, which closes off all but a minimum of airflow to the defroster.
- The blend air door position will channel airflow so that a desired temperature level will be achieved.
- The Blower Motor is on.

Mix

When the Heater Function Selector Switch is in the MIX position:

- The outside-recirc air door and the panel/defrost door are in the “no vacuum” position.
- The floor/panel door is in the partial vacuum position, allowing airflow to the floor and defroster outlets.
- The Blower Motor is on.

Defrost

When the Heater Function Selector Switch is in the DEFROST position:

- The outside-recirc air door is in the “no vacuum” position to admit outside air.
- Both the floor/panel and the panel/defrost doors are in the “no vacuum” position so that most of the incoming air is directed to the defroster nozzles. There is a slight air bleed to the floor outlets.
- The temperature control knob setting will determine the amount of heat being introduced into the airflow.

Blower

With the Ignition Switch in RUN and the Heater Function Selector Switch (on the Heater Control Assembly) in any position except OFF, battery voltage is applied to the Blower Motor. With the Blower Motor Switch in LO, voltage flows through the Blower Motor and all three resistors; in M1, through two resistors; in M2, through one resistor; in HI, through no resistors. With the Heater Function Selector Switch in OFF, the Blower Motor does not run.



7-17 TROUBLESHOOTING/DESCRIPTIONS

SECTION 53 (cont'd)

TROUBLESHOOTING HINTS

CONDITION	POSSIBLE CAUSE	ACTION
<ul style="list-style-type: none"> Blower Motor doesn't work. 	<ul style="list-style-type: none"> No voltage to Blower Motor. Inoperative Blower Motor. 	<ul style="list-style-type: none"> Check Fuse 9. With Heater Function Selector Switch in any position except OFF, check for battery voltage at the (O) circuit to the Blower Motor. With Blower Motor connector removed, there should be less than 3 ohms resistance between 261 (O/BK) wire and ground G200 when Blower Motor Switch is in any position except LO. If not, check Blower Motor Switch, Blower Motor Resistor Assembly and Thermal Limiter. With Blower Motor connector removed, there should be voltage at 249 (DB/LG) wire when Heater Function Selector Switch is in any position but OFF. If not, check Heater Function Selector Switch.
<ul style="list-style-type: none"> Blower runs only in LO. 	<ul style="list-style-type: none"> Inoperative Blower Motor Switch. Open in circuit. 	<ul style="list-style-type: none"> Check for battery voltage at Blower Motor Switch 261 (O/BK) wire. If no voltage, check for an open circuit. If voltage is present, check ground 57 (BK) wire. If ground is good, check Blower Motor Switch.
<ul style="list-style-type: none"> Blower runs only in HI. 	<ul style="list-style-type: none"> Open Thermal Limiter. Open Blower Motor Resistor Assembly or inoperative Blower Motor Switch. 	<ul style="list-style-type: none"> Check continuity of Thermal Limiter in Blower Motor Resistor Assembly. If it is open, check Blower Motor Resistor Assembly and check that all ducts are open to allow free flow of air. Check continuity of Blower Motor Resistor Assembly. Disconnect Blower Motor Switch connector and check continuity of each switch position.
<ul style="list-style-type: none"> Airflow from wrong outlets. 	<ul style="list-style-type: none"> Inoperative vacuum motor or vacuum leak. 	<ul style="list-style-type: none"> Refer to vacuum schematics.

For further diagnostic information, refer to Section 12-00 of the Shop Manual.



BUY IT NOW!
Click Here To Order



AIR CONDITIONER/HEATER HOW THE CIRCUIT WORKS

Blower

With the Ignition Switch in RUN, voltage is applied to the Blower Motor, through the A/C-Heater Control Assembly in all positions except off. In off, there is no power connection to the motor. With the Blower Motor Switch in HI, ground is connected to the motor for full speed operation. In the intermediate positions, one, two or three resistors are connected between

the motor and ground to control current and motor speed.

A/C-Heater

The A/C-Heater Control Assembly and Heater Function Selector Vacuum Valve operate together to control system vacuum and electrical operation. Vacuum motors operate doors to direct airflow. The A/C-Heater Control Assembly connects power to the Blower Motor and A/C Clutch Field Coil (5.0L), or Integrated Control Module (2.3L). For 2.3L engines, the A/C Clutch Field Coil is controlled by an inte-

grated Control Module. This module is regulated by Electronic Engine Control to turn off the A/C System during certain engine operating conditions. However, for 5.0L engines, the A/C Clutch Field Coil is controlled by WOT Cut-out Relay, which is energized by a signal from the EEC Module during WOT and other conditions such as high engine coolant temperatures and low or high engine speeds.

The Clutch Cycling Pressure Switch cuts off power to the A/C Clutch Field Coil when suction pressure drops to 24.5 PSI.

TROUBLESHOOTING HINTS

CONDITION	POSSIBLE CAUSE	ACTION
<ul style="list-style-type: none"> Blower Motor doesn't work. 	<ul style="list-style-type: none"> No voltage to Blower Motor. Inoperative Blower Motor. 	<ul style="list-style-type: none"> Check Fuse 9. With Blower Motor connector removed, there should be less than 3 ohms resistance between 261 (O/BK) wire and ground G200 when Blower Motor Switch is in any position except LO. If not, check Blower Motor Switch, Blower Motor Assembly and Thermal Limiter. With Blower Motor connector removed, there should be voltage at the 249 (DB/LG) wire when A/C-Heater Function Selector Switch is in any position but OFF. If not, check A/C-Heater Function Selector Switch.
<ul style="list-style-type: none"> Blower runs only in LO. 	<ul style="list-style-type: none"> Inoperative Blower Motor Switch. Open in circuit. 	<ul style="list-style-type: none"> Check for battery voltage at Blower Motor Switch 261 (O/BK) wire. If no voltage, check for an open circuit. If voltage is present, check ground 57 (BK) wire. If ground is good, check Blower Motor Switch.
<ul style="list-style-type: none"> Blower runs in HI only. 	<ul style="list-style-type: none"> Open Thermal Limiter. Open Blower Motor Resistor Assembly or inoperative Blower Motor Switch. 	<ul style="list-style-type: none"> Check continuity of Thermal Limiter in Blower Motor Resistor Assembly. If it is open, check Blower Motor Resistor Assembly and check that all ducts are open to allow free flow of air. Check continuity of Blower Motor Resistor Assembly. Check resistor if any portion is open. Remove connector from Blower Motor Switch and check continuity of each switch position. Check Blower Motor Switch if any position is open.



BUY IT NOW!

Click Here To Order



7-19 TROUBLESHOOTING/DESCRIPTIONS

SECTION 54 (cont'd)

TROUBLESHOOTING HINTS

CONDITION	POSSIBLE CAUSE	ACTION
<ul style="list-style-type: none"> ● Airflow from wrong outlets. 	<ul style="list-style-type: none"> ● Inoperative vacuum motor or vacuum leak. 	<ul style="list-style-type: none"> ● Refer to vacuum schematics.
<ul style="list-style-type: none"> ● Compressor Clutch doesn't operate. 	<ul style="list-style-type: none"> ● Low refrigerant charge. ● Open A/C Clutch Field Coil. ● Fuse blown (5.0L). ● Bad WOT Cutout Relay contacts (5.0L). ● Fuse Links blown (2.3L). ● Inoperative Integrated Control Module (2.3L). 	<ul style="list-style-type: none"> ● Check for normal refrigerant charge. ● Remove connector from A/C Clutch Field Coil and measure voltage between 347 (BK/Y), 321 (GY/W) and 57 (BK) wires on the connector. If battery voltage is present, check the A/C Clutch. ● Check Fuse 6. ● Remove WOT Cutout Relay and check continuity between terminal 30 and 87A. ● Visually inspect Fuse Links G, H and J. ● Measure battery voltage at terminals 3, 4, 8 and 12. ● If battery voltage is present, it is possible that the Integrated Control Module is inoperative. Refer to Powertrain Control/Emissions Diagnosis Manual for diagnosis of Integrated Control Module.

For further diagnostic information, refer to Section 12-00 of the Shop Manual.

SECTION 56

REAR WINDOW DEFROST

HOW THE CIRCUIT WORKS

With the Ignition Switch in RUN, the Rear Window Defrost Switch is powered through

Pressing the Rear Window Defrost Switch ON closes the contacts of the Rear Window Defrost Control Relay and starts the ten minute (approximate) timing cycle. Current now flows to the Rear Window Defrost Grid. When the Rear Window Defrost Switch is released from ON, the solid state circuitry keeps the defrost relay coil energized.

Pressing the Rear Window Defrost Switch OFF turns off the defrost relay. This removes power from the Rear Window Defrost circuit.

If the OFF switch is not pressed, power remains on until the time delay runs out. Then the coil turns off and removes power from the Rear Window Defrost Grid circuit.

100% SATISFACTION GUARANTEED

BUY IT NOW!

Click Here To Order

PayPal American Express Discover MasterCard VISA

TROUBLESHOOTING/DESCRIPTIONS 7-20

SECTION 56 (cont'd)

TROUBLESHOOTING HINTS

CONDITION	POSSIBLE CAUSE	ACTION
<ul style="list-style-type: none">● Rear Window Defrost Grid doesn't defrost the window, and ON indicator does not light.	<ul style="list-style-type: none">● No voltage to Rear Window Defrost Switch.	<ul style="list-style-type: none">● Check Fuse Link C and Fuse 5.● Check for voltage at 298 (P/O) wire of Rear Window Defrost Switch with Ignition Switch in RUN.● Check for continuity to ground G100 from Rear Window Defrost Control Relay.
<ul style="list-style-type: none">● ON indicator lights up, but defroster doesn't remove frost.	<ul style="list-style-type: none">● No voltage to Rear Window Defrost Grid.	<ul style="list-style-type: none">● Check for voltage at connector C406 with Rear Window Defrost Switch ON.● Check for continuity to ground G302 from Rear Window Defrost Grid.● If the above checks are good, repair the Rear Window Defrost Grid as described in Section 36-86 of the Shop Manual.

For further diagnostic information, refer to Section 01-11 of the Shop Manual.



7-21 TROUBLESHOOTING/DESCRIPTIONS

SECTION 60

INSTRUMENT CLUSTER

HOW THE CIRCUIT WORKS

Gauges

The Temperature, Oil Pressure, Fuel and Voltmeter Gauges in the Instrument Cluster are magnetic type gauges. A magnetic gauge consists of three primary coils, one of which is wound at a 90 degree angle to the other two. The coils form a magnetic field which varies in direction according to a variable sender resistor connected between two of the coils. A magnet, to which a shaft and pointer are attached, rotates to align with the magnetic field. This results in the gauge pointer being relative to the output of the sender.

Temperature Gauge

The Temperature Gauge connects to the Coolant Temperature Sender. The sender is a temperature-sensitive variable resistor. When coolant temperature is low, resistance is high; when coolant temperature is high, resistance is low.

Oil Pressure Gauge

The Oil Pressure Gauge connects to the Oil Pressure Sender (5.0L) or Oil Pressure Switch (2.3L). For 5.0L only, the sender is a pressure-sensitive variable resistor. When oil pressure is low, resistance is high; when oil pressure is high, resistance is low. For 2.3L only, the is a normally open Oil Pressure Switch.

Fuel Gauge

The Fuel Gauge is connected to the Fuel Gauge Sender through the Slosh Module. The sender is a variable resistor connected to a float in the fuel tank. When fuel level is low, resistance is low; when fuel level is high, resistance is high. The Slosh Module provides a delay circuit to the Fuel Gauge to prevent the gauge from fluctuating excessively due to fuel movement in the tank.

Voltmeter

The Voltmeter measures battery voltage with the Ignition Switch in START or in RUN with the engine not running.

Tachometer

With the Ignition Switch in START or RUN, voltage is present at the Instrument Cluster through Fuse 18 and circuit 640 (R/Y). With the engine running, an intermittent ground signal (proportional to engine speed) is present through the Ignition Module. The Instrument Cluster responds to these inputs by operating the Tachometer needle and indicating the engine's rpms.

Brake Indicator

The Brake Indicator lamp will glow with the Ignition Switch in START to check the warning system. The light will continue to glow if the park brake is not released or when the fluid level in the brake master cylinder reservoir is low.

Check Engine Indicator

The CHECK ENGINE Indicator lamp will come on with the Ignition Switch in the RUN position prior to cranking, and will go out when the engine starts. If a fault develops in the EEC IV System, the EEC Module will ground the 658 (PK/LG) wire to the CHECK ENGINE Indicator and this lamp will glow. If the fault is temporary, the EEC Module will unground the 658 (PK/LG) wire and the lamp will go out.

Check Oil Indicator

The CHECK OIL Indicator lights while the Ignition Switch is in the START position to test the bulb. During this time the Low Oil Level Relay uses an input from the Oil Level Switch to determine if the oil is low (switch grounded) or not low (switch not grounded).

If the oil level is adequate, the Indicator will turn off when the Ignition Switch is released to the RUN position. If the oil level is low (approximately 1.4 liters [1.5 quarts] or less), the Relay will ground circuit 208 (GY) to turn on the lamp. The lamp remains on until the Ignition Switch is turned to the OFF position.

After the Ignition Switch is turned off, five minutes will pass before the Relay will take a new reading. This delay allows time for oil drainback to prevent false readings. If the engine is restarted during this 5 minute period, the last reading will be indicated.



TROUBLESHOOTING/DESCRIPTIONS 7-22

SECTION 60 (cont'd)

Low Coolant Level

When the Ignition Switch is turned to the RUN position, the CHECK COOLANT light will prove out for a couple of seconds and then turn off when the engine is started, indicating adequate coolant fill. If the coolant level in the

recovery bottle is low (below the FULL COLD line when the engine is cold), the CHECK COOLANT light will prove out, delay for about five seconds, then turn back on, indicating a low coolant condition. When indicating a low coolant condition, the CHECK COOLANT light

will latch to the ON position. The CHECK COOLANT light will remain on until the coolant is filled to the FULL HOT line and the vehicle ignition is turned to the off position and then cycled back on.

TROUBLESHOOTING HINTS

CONDITION	POSSIBLE CAUSE	ACTION
<ul style="list-style-type: none"> None of the gauges operate. 	<ul style="list-style-type: none"> No voltage at R/Y wires of Instrument Cluster. No continuity of 57 (BK) wires to ground G100. Open in Instrument Cluster. 	<ul style="list-style-type: none"> Check Fuse 18 and wiring. Check for opens and poor connections in 57 (BK) wires. Check/Repair as required.
<ul style="list-style-type: none"> The Temperature Gauge pointer doesn't move, or the gauge is inaccurate. 	<ul style="list-style-type: none"> Inoperative sending unit or gauge. 	<ul style="list-style-type: none"> Check gauge using Rotunda Instrument Gauge System Tester 021-00055 or equivalent. Check circuit wiring. Check gauge if sender and wiring are OK.
<ul style="list-style-type: none"> Tachometer is inoperative or inaccurate. 	<ul style="list-style-type: none"> Poor connections. 	<ul style="list-style-type: none"> Check voltage and ground to Tachometer. Check for 1 ohm or less resistance between terminal 14 of cluster to the negative terminal of the ignition coil. Check flex circuit for opens. Check wiring and gauge connections.
<ul style="list-style-type: none"> A warning indicator is always on. 	<ul style="list-style-type: none"> Inoperative switch. 	<ul style="list-style-type: none"> Disconnect the suspect switch. If the indicator goes out, check the switch. If the indicator is still on, check the related circuit.
<ul style="list-style-type: none"> None of the indicators operate. 	<ul style="list-style-type: none"> No voltage at 640 (R/Y) wires of Instrument Cluster. 	<ul style="list-style-type: none"> Check Fuse 18 and wiring.
<ul style="list-style-type: none"> Indicators stay on when ignition is turned off. 	<ul style="list-style-type: none"> Affected switch shorted to ground. Short to ground in 977 (P/W) wire at connector C250. 	<ul style="list-style-type: none"> Check by comparing with known good switch. Repair shorts in 977 (P/W) wire.



BUY IT NOW!
Click Here To Order







7-23 TROUBLESHOOTING/DESCRIPTIONS

SECTION 60 (cont'd)

TROUBLESHOOTING HINTS

CONDITION	POSSIBLE CAUSE	ACTION
<ul style="list-style-type: none"> ● Brake Indicator does not light. 	<ul style="list-style-type: none"> ● Blown bulb. ● Open in 977 (P/W) wire at connector C250. ● Open in Instrument Cluster Printed Circuit. ● No continuity of affected switches. 	<ul style="list-style-type: none"> ● Check bulb. ● Repair opens in 977 (P/W) wire. ● Check/Repair as necessary. ● Check by comparing with a known good switch.
<ul style="list-style-type: none"> ● CHECK ENGINE Indicator is lit. 	<ul style="list-style-type: none"> ● See Powertrain Control/Emissions Diagnosis Manual. 	
<ul style="list-style-type: none"> ● One gauge does not operate or is inaccurate. 	<ul style="list-style-type: none"> ● See applicable section in Shop Manual, Section 13. 	
<ul style="list-style-type: none"> ● Fuel Gauge pointer always reads full and never moves. 	<ul style="list-style-type: none"> ● Open circuit, connection or wire on 29 (Y/W) wire between Fuel Gauge Sender and Instrument Cluster, or open Fuel Gauge ground. ● Inoperative Instrument Cluster component (Slosh Module, Fuel Gauge or printed circuit). ● Fuel sender float interference. Inoperative Fuel Gauge Sender. 	<ul style="list-style-type: none"> ● Turn ignition off and connect Rotunda Instrument Gauge System Tester #021-00055 into cluster side of Fuel Gauge Sender connector. If Fuel Gauge does not check out as described in the Shop Manual procedure for Fuel Gauge troubleshooting, check for open circuit in wiring before removing and troubleshooting Instrument Cluster. ● Turn ignition off and check resistance between 29 (Y/W) wire and fuel sender ground at Fuel Gauge Sender connector. Resistance at full tank is 155 to 165 ohms, and empty tank is 14 to 18 ohms. If resistance measurement is greater than 165 ohms, check wiring for open circuit before troubleshooting Fuel Gauge Sender. See Shop Manual for more detailed Fuel Gauge Sender troubleshooting procedure.



BUY IT NOW!
Click Here To Order



TROUBLESHOOTING/DESCRIPTIONS 7-24

SECTION 60 (cont'd)

TROUBLESHOOTING HINTS

CONDITION	POSSIBLE CAUSE	ACTION
<ul style="list-style-type: none"> Fuel Gauge pointer always reads empty and doesn't move. 	<ul style="list-style-type: none"> Short circuit to ground on 29 (Y/W) wire between Fuel Gauge Sender and Instrument Cluster. 	<ul style="list-style-type: none"> Turn ignition off and connect Rotunda Instrument Gauge System Tester #021-00055 into cluster side of Fuel Gauge Sender connector. If Fuel Gauge does not check out as described in Shop Manual procedure for Fuel Gauge troubleshooting, check for short circuit in wiring before removing and troubleshooting Instrument Cluster. Turn ignition off and check resistance between 29 (Y/W) wire and Fuel Gauge Sender ground on Fuel Gauge Sender side of 14405 connection. Resistance at full tank is 155 to 165 ohms; an empty tank is 14 to 18 ohms. If resistance measurement is less than 14 ohms, check wiring for short circuit before troubleshooting Fuel Gauge Sender. See Shop Manual for more detailed Fuel Gauge Sender troubleshooting procedure.
<ul style="list-style-type: none"> Fuel Gauge pointer erratic; remains at one position then moves to another position. 	<ul style="list-style-type: none"> Intermittent open or short circuit on wiring of Fuel Gauge Sender to Instrument Cluster, Fuel Gauge ground, or ignition 640 (R/Y) wire. Inoperative Instrument Cluster component (Slosh Module, Fuel Gauge or printed circuit). Fuel Gauge Sender float interference Inoperative Fuel Gauge Sender. 	<ul style="list-style-type: none"> Turn ignition off and connect Rotunda Instrument Gauge System Tester #021-00055 into cluster side of Fuel Gauge Sender connector. If Fuel Gauge does not check out as described in the Shop Manual procedure for Fuel Gauge troubleshooting, check for intermittent open or short circuit in wiring before troubleshooting Instrument Cluster. Turn ignition off and check resistance between 29 (Y/W) wire and Fuel Gauge Sender ground at Fuel Gauge Sender connector. Resistance at full tank is 155 to 165 ohms, an empty tank is 14 to 18 ohms. If resistance measurement is greater than 165 ohms or less than 14 ohms, check for intermittent open or short circuit in wiring before troubleshooting Fuel Gauge Sender. See Shop Manual for more detailed Fuel Gauge Sender troubleshooting procedure.
<ul style="list-style-type: none"> Voltmeter is inoperative or inaccurate (High/Low). 	<ul style="list-style-type: none"> Battery voltage is High or Low. Open or poor connections. Gauge is inoperative. 	<ul style="list-style-type: none"> Service Battery/charging system as required. Check wiring and gauge connections and voltages. Check gauge.



BUY IT NOW!
Click Here To Order



7-25 TROUBLESHOOTING/DESCRIPTIONS

SECTION 60 (cont'd)

TROUBLESHOOTING HINTS

CONDITION	POSSIBLE CAUSE	ACTION
<ul style="list-style-type: none"> Oil gauge pointer never moves. 	<ul style="list-style-type: none"> Inoperative gauge or sending unit, or open circuit in wiring. 	<ul style="list-style-type: none"> Turn ignition OFF and connect Rotunda Instrument Gauge System Tester, #021-00055 into wiring harness side of oil pressure connector. If oil gauge does not check out as described in the Shop Manual procedure for oil gauge troubleshooting, check for intermittent open or short in wiring before troubleshooting cluster.
<ul style="list-style-type: none"> Oil gauge pointer erratic. 	<ul style="list-style-type: none"> Intermittent open or short in wiring between oil sender and Instrument Cluster, intermittent oil gauge ground, or erratic oil sender. 	<ul style="list-style-type: none"> Turn ignition OFF and connect Rotunda Instrument Gauge System Tester, #021-00055 into wiring harness side of oil pressure connector. If oil gauge does not check out as described in the Shop Manual procedure for oil gauge troubleshooting, check for intermittent open or short in wiring before troubleshooting cluster.

For further diagnostic information, refer to Section 13-00 of the Shop Manual.

SECTION 64

VEHICLE SPEED SENSOR (VSS)

HOW THE CIRCUIT WORKS

The Vehicle Speed Sensor (VSS) is a small signal generator that is turned by a gear inside

the transmission assembly. The Vehicle Speed Sensor (VSS) produces a signal that is proportional to vehicle road speed.

The Vehicle Speed Sensor (VSS) supplies this signal to the components that require ve-

hicle speed information including the Speed Control Amplifier (on Speed Control equipped vehicles) and the Electronic Engine Control (EEC) Module.

For further diagnostic information, refer to Section 17 (Test DP) in the Powertrain Control/Emissions Diagnosis Manual.



WARNING CHIME

HOW THE CIRCUIT WORKS

Key Warning

The Warning Chime sounds when the driver's door is open and the key is in the Ignition Switch, and keeps sounding until the door is closed or the key is removed. When the driver's door is open, power is supplied to the Warning Chime Module through circuit 159 (R/PK). When the key is in the ignition, ground is supplied to the Warning Chime Module through circuit 158 (BK/PK).

Fasten Belts

When the Ignition Switch is turned to the START or RUN position, power is supplied through circuit 640 (R/Y) to the Warning Chime Module, which supplies power through circuit 450 (DG/LG) to illuminate the Fasten Belts indicator for approximately six seconds.

If the driver's safety belt is not fastened, ground is supplied from the Seat Belt Switch through circuit 85 (BR/LB) to the Warning Chime Module and it sounds during the six seconds that the Fasten Belts Indicator is illuminated.

Lights On

The Warning Chime will sound when opening the driver's door with the Main Light Switch in PARK or HEAD, until the door is closed or the Headlamps are turned OFF. When the driver's door is open, power is supplied through circuit 159 (R/PK) to the Warning Chime Module. When the Main Light Switch is in PARK or HEAD, power is supplied through circuit 14 (BR) to the Warning Chime Module.

TROUBLESHOOTING HINTS

CONDITION	POSSIBLE CAUSE	ACTION
<ul style="list-style-type: none"> Warning does not sound for any condition. 	<ul style="list-style-type: none"> Warning Chime Module not properly installed to connector. Open circuit in 57 (BK) wire between Warning Chime Module connector C2013 and ground G100. 	<ul style="list-style-type: none"> Clean and properly re-install Warning Chime Module terminals in connector. Remove connector C2013 from Warning Chime Module and check for ground at terminal of 57 (BK) wire. If ground is not present, repair 57 (BK) wire.
<ul style="list-style-type: none"> Warning sounds intermittently for no apparent reason with all doors closed. 	<ul style="list-style-type: none"> Inoperative Left Front Courtesy Lamp Switch. 	<ul style="list-style-type: none"> Remove connector C2013 from Warning Chime Module and measure voltage at terminal of 159 (R/PK) wire while the left door is closed. If voltage is 2 volts or higher, or if switch appears damaged, check switch.
<ul style="list-style-type: none"> Warning sounds for no apparent reason with left door open (key out of Ignition Switch, Main Light Switch OFF). 	<ul style="list-style-type: none"> Inoperative Ignition Key Warning Switch. Inoperative Main Light Switch. 	<ul style="list-style-type: none"> Remove connector C2013 from Warning Chime Module and check that terminal of 158 (BK/PK) wire is not grounded when key is out of Ignition Switch. If ground is present, repair Ignition Key Warning Switch. Remove connector C2013 from Warning Chime Module and check that battery voltage is not present at terminal of 14 (BR) wire when Main Light Switch is in OFF position. If voltage is present, repair Main Light Switch assembly.

100% SATISFACTION GUARANTEED

BUY IT NOW!

Click Here To Order

PayPal American Express Discover MasterCard VISA

7-27 TROUBLESHOOTING/DESCRIPTIONS

SECTION 66 (cont'd)

TROUBLESHOOTING HINTS

CONDITION	POSSIBLE CAUSE	ACTION
<ul style="list-style-type: none"> Both fasten belts warning chime and Fasten Belts Indicator do not operate. 	<ul style="list-style-type: none"> Fuse 18 blown. Open circuit in 640 (R/Y) wire between Warning Chime Module connector C2013 and Fuse 18. 	<ul style="list-style-type: none"> Check Fuse 18. Remove connector C2013 from Warning Chime Module and check for battery voltage on 640 (R/Y) wire with Ignition Switch in RUN. If battery voltage is not present, service 640 (R/Y) wire.
<ul style="list-style-type: none"> No fasten belts chime, but Fasten Belts Indicator works normally. 	<ul style="list-style-type: none"> Inoperative Seat Belt Switch. Open circuit in 85 (BR/LB) wire between Warning Chime Module and Seat Belt Switch. Open circuit in 57 (BK) wire between Seat Belt Switch and ground G301. 	<ul style="list-style-type: none"> Remove connector C2013 from Warning Chime Module and check that ground is present at terminal of the 85 (BR/LB) wire when the seat belt is unbuckled. If ground is not present, repair Seat Belt Switch and/or check for opens in 85 (BR/LB) wire or 57 (BK) wire.
<ul style="list-style-type: none"> Fasten Belts Indicator does not illuminate, but fasten belts warning chime sounds normally. 	<ul style="list-style-type: none"> Fasten Belts Indicator bulb burned out. Open circuit in 450 (DG/LG) wire between Warning Chime Module connector and bulb. Open circuit in 57 (BK) wire between bulb and ground G100. 	<ul style="list-style-type: none"> Check bulb. Remove connector C2013 from Warning Chime Module and check for ground at terminal of 450 (DG/LG) wire. If ground is not present, check for opens in 450 (DG/LG) wire and 57 (BK) wire.



TROUBLESHOOTING/DESCRIPTIONS 7-28

SECTION 66 (cont'd)

TROUBLESHOOTING HINTS

CONDITION	POSSIBLE CAUSE	ACTION
<ul style="list-style-type: none"> No Key-in-Ignition reminder chime. 	<ul style="list-style-type: none"> Fuse 8 blown. Inoperative Ignition Key Warning Switch or open 158 (BK/PK) circuit. Inoperative Left Front Courtesy Lamp Switch or open 159 (R/PK) circuit. 	<ul style="list-style-type: none"> Check Fuse 8. Remove connector C2013 from Warning Chime Module and check for ground at terminal of 158 (BK/PK) wire with key in Ignition Switch. If ground is not present, check Ignition Key Warning Switch and/or repair 158 (BK/PK) wire. Remove connector C2013 from Warning Chime Module and check for battery voltage at terminal of 159 (R/PK) wire when left door is open. If battery voltage is not present, check Left Front Courtesy Lamp Switch and/or repair 159 (R/PK) wire.
<ul style="list-style-type: none"> No Lights ON reminder chime. 	<ul style="list-style-type: none"> Fuse 8 blown. Inoperative Main Light Switch or open circuit in 14 (BR) wire. Inoperative Left Front Courtesy Lamp Switch or open circuit in 159 (R/PK) wire. 	<ul style="list-style-type: none"> Check Fuse 8. Remove connector C2013 from Warning Chime Module and check for battery voltage at terminal of 14 (BR) wire with Main Light Switch in PARK or HEAD. If battery voltage is not present, service Main Light Switch and/or repair 14 (BR) wire. Remove connector C2013 from Warning Chime Module and check for battery voltage at terminal of 159 (R/PK) wire when left door is open. If battery voltage is not present, check Left Front Courtesy Lamp Switch and/or repair 159 (R/PK) wire.

For further diagnostic information, refer to Section 13-00 of the Shop Manual.

SECTION 71

INSTRUMENT ILLUMINATION

THE CIRCUIT WORKS

BUY IT NOW!

Click Here To Order

the Main
the Main

Light Switch is set to PARK or HEAD, voltage is applied through Fuse 13 to the Instrument Illumination Lamps. The Instrument Panel Dimming Rheostat adjusts the voltage applied to the Instrument Illumination Lamps.

LCD Illumination Relay

With the Ignition Switch in ACC or RUN and with the Main Light Switch off, the LCD Illumination Relay is deenergized. Battery voltage is



7-29 TROUBLESHOOTING/DESCRIPTIONS

SECTION 71 (cont'd)

applied through Fuse 6 and the LCD Illumination Relay to the Electronic Radio.

When the Main Light Switch is on, the LCD Illumination Relay is energized and battery voltage is applied through circuit 14 (BR), and the

resistor dims the LCD Illumination in the Electronic Radio.

TROUBLESHOOTING HINTS

CONDITION	POSSIBLE CAUSE	ACTION
<ul style="list-style-type: none"> None of the Instrument Illumination Lamps work. 	<ul style="list-style-type: none"> If Exterior Lamps work, no voltage at 19 (LB/R) wires of Instrument Illumination Lamps. If Exterior Lamps don't work, no voltage at 195 (T/W) wire of Main Light Switch and/or 14 (BR) wires of Instrument Panel Dimming Rheostat. Inoperative Instrument Panel Dimming Rheostat. 	<ul style="list-style-type: none"> Check Fuse 13 and wiring. Check Fuse 4, Main Light Switch and wiring. Check by comparing with known good dimmer.
<ul style="list-style-type: none"> One Lamp is not working. 	<ul style="list-style-type: none"> Blown bulb. No continuity of 57 (BK) wire from socket to ground. 	<ul style="list-style-type: none"> Check bulb. Repair opens in 57 (BK) wire.
<ul style="list-style-type: none"> LCD Illumination in Radio does not brighten with Exterior Lamps off. 	<ul style="list-style-type: none"> No voltage at 484 (O/BK) wire of Radio. 	<ul style="list-style-type: none"> Check Fuse 6 and wiring. Check the continuity of LCD Illumination Relay contacts between terminals 3 and 5. If open, service relay.



BUY IT NOW!
Click Here To Order







SECTION 71 (cont'd)

TROUBLESHOOTING HINTS

CONDITION	POSSIBLE CAUSE	ACTION
<ul style="list-style-type: none"> LCD Illumination in Radio doesn't dim with Exterior Lamps on. 	<ul style="list-style-type: none"> No voltage at 19 (LB/R) wire of LCD Illumination Relay. No continuity of 57 (BK) wire from LCD Illumination Relay to ground. No continuity of LCD Illumination Relay 19 (LB/R) wire to 484 (O/BK) wire with relay energized. 	<ul style="list-style-type: none"> Check 19 (LB/R) wire for opens. Check 57 (BK) wire for opens. Check relay.

For further diagnostic information, refer to Section 17-02 of the Shop Manual.

SECTION 81

INTERVAL WIPER/WASHER

HOW THE CIRCUIT WORKS

The Interval Wiper/Washer allows the driver to select LO speed, HI speed or Interval wipe. With the wipers in the interval position, wipes are spaced two to ten seconds apart.

The Interval Wiper/Washer Switch has a momentary Washer Switch, a four-position Wiper Switch and a Variable Resistor which sets interval time.

LO/Hi Speed Wiper Operation

When the Wiper Switch is in the LO or HI position, section A of the Wiper Switch powers the interval override input so that the Electronic Switch and the Governor Relay are pulled in continuously. Wiper Motor current then flows through Fuse 2 and the energized Governor Relay contacts to the L terminal of the Wiper Motor. Power is applied to the H terminal of the Wiper Motor through section B of the Wiper Switch for HI speed operation.

Interval Wiper Operation

During interval operation, the wipers make single wipes at lo speed separated by a variable length pause.

When first switched to INT position, section B of the Wiper Switch activates the Interval Timer. The Interval Timer momentarily closes the Electronic Switch, energizing the Governor Relay. Current flows to the Wiper Motor L terminal through the contacts of the energized Governor Relay. Ground is connected to terminal C of the Wiper Motor.

of knob
Washer

BUY IT NOW!

Click Here To Order

7-31 TROUBLESHOOTING/DESCRIPTIONS

SECTION 81 (cont'd)

As the Wiper Motor turns, the Wiper Motor Switch changes from the grounded PARK position contact, which is not powered, and the Wiper Motor stops. After a pause (controlled by the variable resistor), the Interval Timer pulls in the Governor Relay to start another wipe.

When parking is complete, the Wiper Motor is braked to a stop by shunting the L and C terminals through the Wiper Motor Switch. Braking takes place when the Wiper Motor Switch moves to the PARK position. The Wiper Motor L

terminal is connected to terminal C through the PARK contact of the Wiper Motor Switch and the deenergized contact of the Governor Relay.

TROUBLESHOOTING HINTS

CONDITION	POSSIBLE CAUSE	ACTION
<ul style="list-style-type: none"> Wipers don't operate in interval mode. 	<ul style="list-style-type: none"> Open circuit in Interval Adjust control. Open interval contact of Wiper Switch. 	<ul style="list-style-type: none"> Remove the connector from the Interval Wiper/Washer Switch and measure resistance between terminals R1 and R2 while turning the Interval Adjust Control through its entire range. If resistance varies uniformly, check continuity between terminals I and B when the Interval Wiper/Washer Switch is in INT position. If continuity is present, check Interval Governor.
<ul style="list-style-type: none"> Wipers don't operate in LO. 	<ul style="list-style-type: none"> Inoperative Interval Governor. 	<ul style="list-style-type: none"> Disconnect connector C151. If battery voltage is not present at the 58 (W) wire of the harness connector with the Wiper Switch in LO, check the Interval Governor. If voltage is present, check the Windshield Wiper Motor.
<ul style="list-style-type: none"> Wipers don't operate in HI. 	<ul style="list-style-type: none"> Inoperative Interval Wiper/Washer Switch. 	<ul style="list-style-type: none"> Disconnect connector C151. If battery voltage is not present at the 56 (DB/O) wire of the harness connector with the Wiper Switch in HI, check the Interval Wiper/Washer Switch. If voltage is present, check the Windshield Wiper Motor.
<ul style="list-style-type: none"> Windshield Washer is inoperative. 	<ul style="list-style-type: none"> Low washer fluid. Cracked or kinked washer hose. Inoperative Washer Switch. Inoperative Windshield Washer Pump Motor. 	<ul style="list-style-type: none"> Check fluid level. Check hoses for leaks and kinks. Check switch continuity (refer to Section 35-60 of the Shop Manual). Check 941 (BK/W) wire and 57 (BK) wire.

100% SATISFACTION GUARANTEED

BUY IT NOW!

Click Here To Order

PayPal American Express Discover MasterCard VISA

TROUBLESHOOTING/DESCRIPTIONS 7-32

SECTION 81 (cont'd)

TROUBLESHOOTING HINTS

CONDITION	POSSIBLE CAUSE	ACTION
<ul style="list-style-type: none"> Windshield Wipers don't park. 	<ul style="list-style-type: none"> No voltage at Windshield Wiper Motor. Inoperative Park Switch. 	<ul style="list-style-type: none"> Check voltage at harness half of Windshield Wiper Motor connector. There should be battery voltage at all times. Check continuity at motor half of Windshield Wiper Motor connector, which should be open when Wipers are parked. There should be continuity when the wipers are on windshield.

For further diagnostic information, refer to Section 01-06 of the Shop Manual.

SECTION 85

HEADLAMPS

HOW THE CIRCUIT WORKS

Power to operate the Headlamps flows through the Main Light Switch and the Dimmer

Switch. When the Dimmer Switch lever is pulled partway toward the driver, the Flash-to-pass Switch closes, providing power to the Hi Beam Headlamps from Fuse 10.

TROUBLESHOOTING HINTS

CONDITION	POSSIBLE CAUSE	ACTION
<ul style="list-style-type: none"> Headlamps don't work in HI or LO; passing beam OK. 	<ul style="list-style-type: none"> No voltage to Headlamps. Inoperative Multi-function Switch. 	<ul style="list-style-type: none"> With Main Light Switch in HEAD position, check for voltage at connector C268, 15 (R/Y) circuit. If OK, check 13 (R/BK) circuit at connector C268 with Dimmer Switch in LO.
<ul style="list-style-type: none"> Headlamps OK; no passing beam. 	<ul style="list-style-type: none"> No voltage to Headlamps. Inoperative Flash-to-pass Switch. 	<ul style="list-style-type: none"> Check Fuse 10. Check for voltage at Multi-function Switch 196 (DB/O) circuit. If OK, check Flash-to-pass Switch.
	<ul style="list-style-type: none"> Inoperative Dimmer Switch. Open in 13 (R/BK) circuit. 	<ul style="list-style-type: none"> Attach a jumper across Multi-function Switch 15 (R/Y) and 13 (R/BK) circuits. If lamps light, check Dimmer Switch.



BUY IT NOW!
Click Here To Order



7-33 TROUBLESHOOTING/DESCRIPTIONS

SECTION 85 (cont'd)

TROUBLESHOOTING HINTS

CONDITION	POSSIBLE CAUSE	ACTION
<ul style="list-style-type: none"> Lo Beams work; no Hi Beams. 	<ul style="list-style-type: none"> Inoperative Dimmer Switch. Open in 12 (LG/BK) circuit. 	<ul style="list-style-type: none"> If Hi Beam Indicator and Hi Beams don't work, check switch. If battery voltage is present at the 12 (LG/BK) wire of the Multi-function Switch terminal when it is in HI, check for open 12 (LG/BK) wires.
<ul style="list-style-type: none"> Any one Headlamp is inoperative. 	<ul style="list-style-type: none"> Open bulb. No voltage to inoperative Headlamp. Open ground circuit to inoperative Headlamp. 	<ul style="list-style-type: none"> Check Headlamp bulb continuity. Check Headlamp bulb socket for voltage. Check Headlamp bulb socket for continuity to ground.
<ul style="list-style-type: none"> All Right Headlamps light dimly or don't light; Left Headlamps are OK. 	<ul style="list-style-type: none"> Poor ground connection or open ground circuit. 	<ul style="list-style-type: none"> Check continuity to ground.
<ul style="list-style-type: none"> All Left Headlamps light dimly or don't light. 	<ul style="list-style-type: none"> Poor ground connection or open ground circuit. 	<ul style="list-style-type: none"> Check continuity to ground.

For further diagnostic information, refer to Section 17-01 of the Shop Manual.

SECTION 86

FOG LAMPS

HOW THE CIRCUIT WORKS

With the Lo Beam Headlamps on, voltage is
 sent through Fuse 15 to the Fog Lamp
 Switch. With the Fog Lamp Switch on, voltage
 goes to the Fog Lamps and they turn on.

100% SATISFACTION GUARANTEED

BUY IT NOW!

Click Here To Order

PayPal American Express Discover MasterCard VISA

TROUBLESHOOTING/DESCRIPTIONS 7-34

SECTION 86 (cont'd)

TROUBLESHOOTING HINTS

CONDITION	POSSIBLE CAUSE	ACTION
<ul style="list-style-type: none"> Fog Lamps don't work. 	<ul style="list-style-type: none"> No voltage to Fog Lamps. Inoperative switch. 	<ul style="list-style-type: none"> Check Fuse 15, connector C108 and the 478 (T/O) circuit. Attach a fused jumper across the Fog Lamp Switch connector between 477 (LB/BK) and 478 (T/O) wires and turn the Lo Beam Headlamps on; if the Fog Lamps light, check the Fog Lamp Switch.
<ul style="list-style-type: none"> Only one Fog Lamp comes on. 	<ul style="list-style-type: none"> Open in circuit. 	<ul style="list-style-type: none"> Check bulb. Check for voltage at inoperative Fog Lamp 478 (T/O) circuit. Check continuity of 57 (BK) circuit to ground.

For further diagnostic information, refer to Section 17-01 of the Shop Manual.

SECTION 89

COURTESY LAMPS

HOW THE CIRCUIT WORKS

Voltage is applied, at all times, through Fuse 8 to the Instrument Panel Dimming Rheostat, Courtesy Lamp Switches and other switches for individual lamps.

stat, Courtesy Lamp Switches and other switches for individual lamps.

Switch is closed, current flows through the Dome Lamp.

If the Instrument Panel Dimming Rheostat knob is turned fully ON, or if a Courtesy Lamp

TROUBLESHOOTING HINTS

CONDITION	POSSIBLE CAUSE	ACTION
<ul style="list-style-type: none"> Any one lamp doesn't light. 	<ul style="list-style-type: none"> Open bulb. Open ground circuit. 	<ul style="list-style-type: none"> Check bulb socket for voltage. Check bulb continuity. Check bulb socket contact for continuity to ground.
<ul style="list-style-type: none"> No voltage to common power point. 	<ul style="list-style-type: none"> No voltage to common point. 	<ul style="list-style-type: none"> Check fuse supplying common point. Check switch supplying common circuit. Check wiring to common point.

100% SATISFACTION GUARANTEED

BUY IT NOW!

Click Here To Order

PayPal American Express Discover MasterCard VISA

7-35 TROUBLESHOOTING/DESCRIPTIONS

SECTION 89 (cont'd)

TROUBLESHOOTING HINTS

CONDITION	POSSIBLE CAUSE	ACTION
<ul style="list-style-type: none"> Lamps with common ground don't light. 	<ul style="list-style-type: none"> Open in ground circuit. 	<ul style="list-style-type: none"> Check continuity between common point and ground.

For further diagnostic information, refer to Section 17-02 of the Shop Manual.

SECTION 90

TURN/STOP/HAZARD LAMPS

HOW THE CIRCUIT WORKS

Turn Signals

With the Ignition Switch in RUN, voltage is applied to the Hazard Warning Switch and the Multi-function Switch through Fuse 5 and the Turn Signal Flasher.

When the Multi-function Switch is in the LEFT turn or RIGHT turn position, voltage is applied to either the Left or Right Turn Lamps.

Hazard Flasher

Voltage is applied to the Turn Lamps through Fuse 1 and the Hazard Flasher when the Hazard Switch is in the HAZARD position.

Stop Lamps

Voltage is applied to the Stop Lamps through Fuse 1 when the Stop Lamp Switch is closed.

TROUBLESHOOTING HINTS

CONDITION	POSSIBLE CAUSE	ACTION
<ul style="list-style-type: none"> Hazard Lamps don't work; Turn Lamps do work. 	<ul style="list-style-type: none"> Blown Fuse. Inoperative Hazard Flasher. Inoperative Hazard Warning Switch. 	<ul style="list-style-type: none"> Check Fuse 1. With Hazard Warning Switch turned on, remove Hazard Flasher and connect a fused jumper between 383 (R/W) and 385 (W/R) wires. If Park/Turn Lamps turn on and stay on, check Hazard Flasher. If Park/Turn Lamps don't turn on, check 383 (R/W) and 385 (W/R) wires for opens. If OK, check Hazard Warning Switch.
<ul style="list-style-type: none"> Hazard Lamps stay on (don't flash). 	<ul style="list-style-type: none"> Inoperative Hazard Flasher. 	<ul style="list-style-type: none"> Check Hazard Flasher.

100% SATISFACTORY GUARANTEED

BUY IT NOW!

Click Here To Order

PayPal American Express Discover MasterCard VISA

TROUBLESHOOTING/DESCRIPTIONS 7-36

SECTION 90 (cont'd)

TROUBLESHOOTING HINTS

CONDITION	POSSIBLE CAUSE	ACTION
<ul style="list-style-type: none"> Turn Lamps don't work; Hazard Lamps do work. 	<ul style="list-style-type: none"> Blown Fuse. Inoperative Turn Signal Flasher. Inoperative Multi-function Switch. 	<ul style="list-style-type: none"> Check Fuse 5. With Ignition Switch in RUN, remove Turn Signal Flasher and connect a fused jumper between 298 (P/O) and 44 (LB) wires. With Multi-function Switch in LEFT turn position, the Left Park/Turn Lamps should turn on and stay on. If they do, check Turn Signal Flasher. If Left Park/Turn lamps don't turn on, check 298 (P/O) and 44 (LB) wires for opens. If OK, check Multi-function Switch.
<ul style="list-style-type: none"> Turn Lamps stay on (don't flash) for both left and right turn. 	<ul style="list-style-type: none"> Inoperative Turn Signal Flasher. 	<ul style="list-style-type: none"> Check Turn Signal Flasher.
<ul style="list-style-type: none"> Turn Lamps and Indicator work on one side only. 	<ul style="list-style-type: none"> Inoperative Multi-function switch. 	<ul style="list-style-type: none"> Check Multi-function Switch.
<ul style="list-style-type: none"> All Stop Lamps stay on without brake pedal depressed. 	<ul style="list-style-type: none"> Inoperative Stop Lamp Switch. 	<ul style="list-style-type: none"> Check Stop Lamp Switch. Check vacuum dump valve adjustment. Check brake pedal pivot for binding condition (must move freely when not connected to booster).
<ul style="list-style-type: none"> None of the Stop Lamps work. 	<ul style="list-style-type: none"> Fuse 1 blown. Broken wire. 	<ul style="list-style-type: none"> Check Fuse 1. Check 10 (LG/R) and 810 (R/LG) wires at entrance to Stop Lamp Switch connector for continuity.

For further diagnostic information, refer to Section 17-01 of the Shop Manual.



7-37 TROUBLESHOOTING/DESCRIPTIONS

SECTION 92

EXTERIOR LAMPS

HOW THE CIRCUIT WORKS

When the Main Light Switch is turned to PARK or HEAD, battery voltage is applied

through Fuse 4 to the Park, Side Marker and License Lamps. All of these lamps are permanently grounded and light up whenever voltage is applied.

TROUBLESHOOTING HINTS

CONDITION	POSSIBLE CAUSE	ACTION
<ul style="list-style-type: none">None of the Exterior Lamps light, but Headlamps function normally.	<ul style="list-style-type: none">No voltage at 195 (T/W) wire of Main Light Switch.No voltage at 14 (BR) wire of lamps.Inoperative Main Light Switch.	<ul style="list-style-type: none">Check Fuse 4.With Main Light Switch in PARK or HEAD, check battery voltage at 14 (BR) wire terminal.Check Main Light Switch for proper operation.
<ul style="list-style-type: none">One lamp doesn't light.	<ul style="list-style-type: none">Blown bulb.Open ground circuit.	<ul style="list-style-type: none">Check bulb continuity.Check bulb socket contact for continuity to ground.

For further diagnostic information, refer to Section 17-01 of the Shop Manual.

SECTION 93

BACKUP LAMPS

HOW THE CIRCUIT WORKS

With the Ignition Switch in RUN, voltage is applied from Fuse 5 to the Backup Lamp Switch (Manual) or to the Backup/Neutral Safety Switch (Automatic). With the Backup Lamp Switch (Manual) or the Backup/Neutral Safety Switch (Automatic) in the ON position, voltage is applied to the Backup

100% SATISFACTION GUARANTEED

BUY IT NOW!

Click Here To Order

PayPal American Express Discover MasterCard VISA

TROUBLESHOOTING HINTS

CONDITION	POSSIBLE CAUSE	ACTION
<ul style="list-style-type: none"> Backup Lamps don't work. 	<ul style="list-style-type: none"> No voltage to lamps. 	<ul style="list-style-type: none"> Check Fuse 5 by operating turn signals. Check for voltage at the Backup Lamps, 140 (BK/PK) wire. Check continuity of 57 (BK) wire to ground. Attach a fused jumper across the Backup Lamp Switch or Backup/Neutral Safety Switch. If lamp operates, check switch.
<ul style="list-style-type: none"> Backup Lamps stay on. 	<ul style="list-style-type: none"> Inoperative Backup Lamp Switch. 	<ul style="list-style-type: none"> Check for short circuit in Backup Lamp Switch or Backup/Neutral Safety Switch by disconnecting connector C106. Check switch if light turns off.

For further diagnostic information, refer to Section 17 of the Shop Manual.

SECTION 97

DAYTIME RUNNING LAMPS (CANADIAN VEHICLES ONLY)

HOW THE CIRCUIT WORKS

The Daytime Running Lamps (DRL) System operates the vehicle's Hi Beam Headlamps at reduced power during the daytime to make the vehicle more visible to other drivers.

With the Ignition Switch in RUN, the park brake released, and the Headlamps turned OFF, the DRL Module outputs a pulsing voltage to operate the Hi Beam Headlamps at reduced power. The DRL System is operated only on vehicles equipped with the DRL System.

Applying the park brake or turning on the Headlamps disables the DRL System. Applying the park brake grounds pin 6 of the DRL Module. Turning on the Headlamps in the lo beam position supplies battery voltage to pin 7 of the module (and removes the ground input that the DRL Module senses through the Lo Beam Headlamps). Turning on the Headlamps in the hi beam position applies 12 volts to pin 8 of the DRL Module.

The diode shown inside the DRL Module prevents low brake fluid level from disabling the DRL System.

The DRL System is used only on vehicles sold in Canada.

NOTE:

The headlamps may flicker during engine start-up and shut-down on DRL-equipped vehicles if the A/C-Heater Blower Motor is turned ON. This is a normal condition.

Also, during Lo Beam Headlamp operation on a DRL-equipped vehicle, the Hi Beam Indicator will not illuminate when using the flash-to-pass feature.

100% SATISFACTION GUARANTEED

BUY IT NOW!

Click Here To Order

PayPal American Express Discover MasterCard VISA

7-39 TROUBLESHOOTING/DESCRIPTIONS

SECTION 97 (cont'd)

TROUBLESHOOTING HINTS

CONDITION	POSSIBLE CAUSE	ACTION
<ul style="list-style-type: none"> Daytime Running Lamps don't operate. 	<ul style="list-style-type: none"> Blown fuse. Open or poor ground connection. 22 (LB/BK) wire shorted to ground. Inoperative Daytime Running Lamps (DRL) Module. 	<ul style="list-style-type: none"> Check Fuses 5 and 10. Check ground connections. With Park Brake fully released, check for a short between the 22 (LB/BK) wire and ground. Check for voltage at the 196 (DB/O) and 298 (P/O) wires. Check for voltage at the 12 (LG/BK) wire with the Ignition Switch in RUN, Brake fully released and Headlamps off. If no voltage is present, check Module.
<ul style="list-style-type: none"> Daytime Running Lamps won't turn off with Main Light Switch in HEAD. 	<ul style="list-style-type: none"> Open in 13 (R/BK) wire. Inoperative Daytime Running Lamps (DRL) Module. 	<ul style="list-style-type: none"> With Main Light Switch in HEAD and Dimmer Switch in LO, check for voltage on the 13 (R/BK) wire of Daytime Running Lamps (DRL) Module. If voltage is present, check Module.
<ul style="list-style-type: none"> Hi Beam Headlamp on one side doesn't operate. 	<ul style="list-style-type: none"> Open or poor ground connection. Blown Headlamp. 	<ul style="list-style-type: none"> Check ground connection. Check Headlamp.

For further diagnostic information, refer to Section 17-01 of the Shop Manual.

SECTION 100

POWER WINDOWS

HOW THE CIRCUIT WORKS

Window Control Switch in each door
Motor in direction



100% SATISFACTION GUARANTEED

BUY IT NOW!

Click Here To Order

PayPal, American Express, Discover, MasterCard, VISA

The current causes the Window Motor to turn in a clockwise or counterclockwise direction to raise or lower the window.

In the OFF position, both motor wires are grounded through separate switch contacts.

When the DN switch is pushed, power flows to the DN Motor lead. The UP lead acts as ground.

When the UP switch is pushed, power flows to the UP Motor lead. The DN lead acts as ground.

TROUBLESHOOTING/DESCRIPTIONS 7-40

SECTION 100 (cont'd)

The 2-door and 3-door Power Window Systems are protected by Circuit Breaker 14, which is hot with the Ignition Switch in ACC or RUN position.

The Convertible System is protected by the Window Safety Relay and In-Line Circuit Break-

er. The relay (and the windows) operate in ACC or RUN only.

Each motor assembly also has a circuit breaker to cut off power if a switch is held too long in the UP or DN position.

The Convertible System has a Window Lock Switch which cuts power to the passenger window switches. This allows only the driver to operate the windows from the Master Window Control Switch.

TROUBLESHOOTING HINTS-2 DOOR AND 3 DOOR

CONDITION	POSSIBLE CAUSE	ACTION
<ul style="list-style-type: none"> None of the Power Windows operate. 	<ul style="list-style-type: none"> No voltage at 194(PK) wires of Front Window Control Switch. No continuity of 57(BK) wires from Master Window Control Switch to ground. No continuity through Master Window Control Switch. 	<ul style="list-style-type: none"> Check Circuit Breaker 14 and wiring. Repair opens in 57(BK) wires and check connections. Check by comparing with known good switch.
<ul style="list-style-type: none"> One window doesn't operate. 	<ul style="list-style-type: none"> Inoperative motor. Frayed or damaged wiring or loose connections. 	<ul style="list-style-type: none"> Check motor. Check/repair or tighten as required.
<ul style="list-style-type: none"> Passenger's window operates from one switch only. 	<ul style="list-style-type: none"> Inoperative switch. Frayed or damaged wiring or loose connections. 	<ul style="list-style-type: none"> Check by comparing with known good switch. Check/Repair or tighten as required.
<ul style="list-style-type: none"> In-Line Circuit Breaker opens when one window is operated. 	<ul style="list-style-type: none"> Excessive current drawn by Window Motor. 	<ul style="list-style-type: none"> Perform current draw test described in Shop Manual.



7-41 TROUBLESHOOTING/DESCRIPTIONS

SECTION 100 (cont'd)

TROUBLESHOOTING HINTS-CONVERTIBLE

CONDITION	POSSIBLE CAUSE	ACTION
<ul style="list-style-type: none"> None of the Power Windows operate. 	<ul style="list-style-type: none"> No voltage at 194 (PK) wire of Window Safety Relay. No voltage at 171(BK/W) wire of Window Safety Relay or Master Window Control Switch. Inoperative Window Safety Relay. No continuity of 57(BK) wires from Master Window Control Switch to ground. Inoperative Master Window Control Switch. 	<ul style="list-style-type: none"> Check Circuit Breaker 14. Check In-line Circuit Breaker and wiring. Check by comparing with known good switch. Check relay. Repair opens in 57(BK) wires and check connections. Check by comparing with known good switch.

For further diagnostic information, refer to Section 01-11 of the Shop Manual.

SECTION 102

CONVERTIBLE TOP

HOW THE CIRCUIT WORKS

With the Ignition Switch in RUN, voltage is available through Fuse 5 to the Convertible Top Switch. When the RAISE side of the switch is depressed, voltage is applied through the switch to energize the Raise Relay. Voltage is applied through Fuse Link C. Fuse 12 and the Lower Relay contacts to the Convertible Top Motor.

When the LOWER side of the switch is depressed, the Lower Relay is energized. Voltage from Fuse Link C is then applied through Fuse 12 and the Lower Relay contacts to the Convertible Top Motor.

BUY IT NOW!
Click Here To Order

PayPal American Express Cards Discover MasterCard VISA

TROUBLESHOOTING/DESCRIPTIONS 7-42

SECTION 102 (cont'd)

TROUBLESHOOTING HINTS

CONDITION	POSSIBLE CAUSE	ACTION
<ul style="list-style-type: none"> Convertible Top operates in one direction only. 	<ul style="list-style-type: none"> No ground to Raise or Lower Relay. Inoperative Convertible Top Switch. Inoperative Raise or Lower Relay. Inoperative Convertible Top Motor. 	<ul style="list-style-type: none"> Check continuity to ground of 57 (BK) wire. Check continuity of Convertible Top Switch. Disconnect Convertible Top Switch. Connect a fused jumper from the 298 (P/O) wire of the Convertible Top Switch connector to the 902 (Y) or 903 (R) wire of the Raise or Lower Relay. If Convertible Top Motor operates, check Raise or Lower Relay. If it doesn't operate, check Convertible Top Motor.
<ul style="list-style-type: none"> Convertible Top doesn't operate in either direction. 	<ul style="list-style-type: none"> No voltage at 298 (P/O) wire of Convertible Top Switch. No voltage at 175 (BK/Y) wires of Raise and Lower Relays. No ground to Convertible Top Motor. Inoperative Convertible Top Motor. 	<ul style="list-style-type: none"> Check Fuse 5, Fuse Link C and Fuse 12 for an open. Check continuity to ground of 57 (BK) wire. Connect a fused jumper from 175 (BK/Y) wire to the 902 (Y) or 903 (R) wire of the Convertible Top Motor. If the motor doesn't run, check the Convertible Top Motor.

For further diagnostic information, refer to Section 01-17 of the Shop Manual.

SECTION 110

POWER DOOR LOCKS

IF THE CIRCUIT WORKS

through

ches are
est, all

100% SATISFACTION GUARANTEED

BUY IT NOW!

Click Here To Order

SWITCHES ARE AVAILABLE ONLINE

PayPal American Express Discover MasterCard VISA

When either switch is pressed to LOCK, voltage is applied to both Lock Motors, which are grounded by the normally closed UNLOCK contacts.

To unlock, either switch is pressed to UNLOCK. Voltage is applied in the opposite direction through all the motors, and grounds through the normally closed LOCK contacts.

7-43 TROUBLESHOOTING/DESCRIPTIONS

SECTION 110 (cont'd)

TROUBLESHOOTING HINTS

CONDITION	POSSIBLE CAUSE	ACTION
<ul style="list-style-type: none"> Power Door Locks work from one Door Lock Switch only. 	<ul style="list-style-type: none"> Inoperative Door Lock Switch. 	<ul style="list-style-type: none"> Check continuity of Door Lock Switch.
<ul style="list-style-type: none"> Power Door Locks are completely inoperative. 	<ul style="list-style-type: none"> No voltage at Door Lock Switches. Open in Door Lock Motor circuit. Poor ground connections. 	<ul style="list-style-type: none"> Check In-line Circuit Breaker. Check for voltage on 171 (BK/W) wires at splice S225. Check continuity of the 117 (PK/BK) and 118 (PK/O) wires. Check continuity; tighten as required.
<ul style="list-style-type: none"> Power Door Locks work in either LOCK or UNLOCK, but not in both positions. 	<ul style="list-style-type: none"> Open ground wire at Left Door Lock Switch. 	<ul style="list-style-type: none"> Check continuity to ground of both 57 (BK) wires from the Left Door Lock Switch.
<ul style="list-style-type: none"> Only one Door Lock Motor works. 	<ul style="list-style-type: none"> Inoperative Door Lock Motor. 	<ul style="list-style-type: none"> Check for voltage to motor. Check motor.

For further diagnostic information, refer to Section 01-14 of the Shop Manual.

SECTION 113

TRUNK LID RELEASE

HOW THE CIRCUIT WORKS

With the Ignition Switch in ACC or RUN and the Trunk Lid/Hatchback Release Switch depressed, voltage is applied to the Trunk Lid Release Solenoid or the Hatchback Release Solenoid to unlatch the trunk lid or hatchback.

BUY IT NOW!
Click Here To Order

PayPal American Express Discover MasterCard VISA

TROUBLESHOOTING/DESCRIPTIONS 7-44

SECTION 113 (cont'd)

TROUBLESHOOTING HINTS

CONDITION	POSSIBLE CAUSE	ACTION
<ul style="list-style-type: none">Trunk Lid Release or Hatchback Release doesn't operate.	<ul style="list-style-type: none">No voltage to Trunk Lid or Hatchback Release Solenoid.Inoperative Trunk Lid or Hatchback Release Solenoid.Inoperative Trunk Lid/Hatchback Release Switch.	<ul style="list-style-type: none">Check Fuse 6.Check for battery voltage on 296 (W/P) wire.With Trunk Lid/Hatchback Release Switch closed, check for voltage across the Trunk Lid or Hatchback Release Solenoid between the 84 (P/Y) wire and ground. If OK, check Trunk Lid or Hatchback Release Solenoid.Attach a jumper between the 296 (W/P) wire and 84 (P/Y) wire. If Trunk Lid or Hatchback Release operates, check switch.

For further diagnostic information, refer to Section 01-03 of the Shop Manual.

SECTION 120

POWER SEATS

HOW THE CIRCUIT WORKS

The Driver's Seat Motor Assembly has two reversible motors within the same housing. The Seat Control Switch determines the direction of current flow through the motors. The di-

rection of current flow determines the direction of motor rotation.

A circuit breaker protects each motor when power is supplied to a stalled motor. The motor can stall from either mechanical failure or running to the limit of travel.

The FWD/RWD Motor drives the seat forward and backward.

The Height Motor drives the seat up and down.

The motors are grounded when the switches are at rest.



7-45 TROUBLESHOOTING/DESCRIPTIONS

SECTION 120 (cont'd)

TROUBLESHOOTING HINTS

CONDITION	POSSIBLE CAUSE	ACTION
<ul style="list-style-type: none"> Power Seat is completely inoperative. 	<ul style="list-style-type: none"> No voltage at Control Switch. Loss of ground at Control Switch. 	<ul style="list-style-type: none"> Check Circuit Breaker and BK/W wires for an open. Check for continuity to ground G300.
<ul style="list-style-type: none"> One or more Power Seat positions are inoperative. 	<ul style="list-style-type: none"> Control Switch inoperative. No voltage to motor. Motor inoperative. No ground to motor. 	<ul style="list-style-type: none"> Check suspect Control Switch continuity while operating Switch in UP and DOWN positions. Connect test lamp across control Switch terminals to inoperative motor, and operate Switch in both directions. If lamp lights in both directions, Control Switch is OK. Retest at connector. Check wiring to motor. Check motor for mechanical binding. Check 57 (BK) wire for continuity to ground.

For further diagnostic information, refer to Section 01-10 of the Shop Manual.

SECTION 122

LUMBAR SEATS

HOW THE CIRCUIT WORKS

The In-line Circuit Breaker is hot at all times and applies voltage to the Left and Right Power Lumbar Seat Switches.

The cushion shape of the Lumbar Seat changes when the Power Lumbar Seat Switch is operated. Operating the switch in one direction causes the compressor to inflate the bladder; operating the switch in the other direction causes the bleeder valve to deflate the bladder.

100% SATISFACTION GUARANTEED

BUY IT NOW!

Click Here To Order

PayPal American Express Discover MasterCard VISA

TROUBLESHOOTING/DESCRIPTIONS 7-46

SECTION 122 (cont'd)

TROUBLESHOOTING HINTS

CONDITION	POSSIBLE CAUSE	ACTION
<ul style="list-style-type: none"> Lumbar Seat(s) is/are inoperative. 	<ul style="list-style-type: none"> Open in power feed Power Lumbar to Seat Switch(es). Open feed wire from switch to Compressor. Open ground feed to Power Lumbar Compressor Motor. Inoperative Power Lumbar Compressor Motor. 	<ul style="list-style-type: none"> Measure voltage at Power Lumbar Seat Switch connector(s). Check by measuring battery voltage at Power Lumbar Compressor connector(s). Check continuity to ground at connector C307 or C308, 57 (BK) wire to ground. With Lumbar Seat Switch in ON position and Air Pump disconnected, measure voltage across Power Lumbar Compressor Motor connector.

For further diagnostic information, refer to Section 01-10 of the Shop Manual.

SECTION 124

POWER MIRRORS

HOW THE CIRCUIT WORKS

Each Power Mirror is equipped with two motors operated by a single rocker-type control

switch. The joystick control switch directs current to the motors. By reversing current flow, each motor operates in two directions, creating both left and right (horizontal) and up and down (vertical) movement.

The Left and Right Mirror Switch connects the control to either the Left or Right Power Mirror.

TROUBLESHOOTING HINTS

CONDITION	POSSIBLE CAUSE	ACTION
<ul style="list-style-type: none"> Power mirrors are completely inoperative. 	<ul style="list-style-type: none"> No voltage at Power Mirror Switch. Open ground circuit. 	<ul style="list-style-type: none"> Check Fuse 8. Check for voltage on 54 (LG/Y) wire at connector C350. Check continuity of 57 (BK) wire to ground G301.



BUY IT NOW!
Click Here To Order



7-47 TROUBLESHOOTING/DESCRIPTIONS

SECTION 124 (cont'd)

TROUBLESHOOTING HINTS

CONDITION	POSSIBLE CAUSE	ACTION
<ul style="list-style-type: none"> Left Mirror operates properly; Right Mirror operates in LEFT/RIGHT positions, but is inoperative in UP/DOWN positions. 	<ul style="list-style-type: none"> No voltage to Right Mirror UP/DN Motor. Inoperative Power Mirror Switch. Inoperative motor assembly. 	<ul style="list-style-type: none"> With the selector in RIGHT position, connect a test lamp between 544 (P) wire and 542 (Y) wire at connector C350. Move knob between UP and DOWN positions. If lamp doesn't light in one or both positions, check Power Mirror Switch. If lamp lights in both positions, retest at Right Power Mirror connector. If lamp lights in both positions at Right Power Mirror connector, check motor assembly. If lamp doesn't light, check 544 (P) wire and 542 (Y) wires for an open. Repair as needed.
<ul style="list-style-type: none"> Left Mirror operates properly; Right Mirror operates in UP/DOWN positions, but is inoperative in LEFT/RIGHT positions. 	<ul style="list-style-type: none"> No voltage to Right Mirror L/R Motor. Inoperative Power Mirror Switch. Inoperative motor assembly. 	<ul style="list-style-type: none"> With the selector in RIGHT position, connect a test lamp between 543 (DG) wire and 542 (Y) wire at connector C350. Move knob between LEFT and RIGHT positions. If lamp doesn't light in one or both positions, check Power Mirror Switch. If lamp lights in both positions, retest at Right Power Mirror connector. If lamp lights in both positions at Right Power Mirror connector, check motor assembly. If lamp doesn't light, check 543 (DG) wire and 542 (Y) wire for an open. Repair as needed.
<ul style="list-style-type: none"> Right Mirror operates properly; Left Mirror operates in LEFT/RIGHT positions, but is inoperative in UP/DOWN positions. 	<ul style="list-style-type: none"> No voltage at Left Mirror UP/DN Motor. Inoperative Power Mirror Switch. Inoperative motor assembly. 	<ul style="list-style-type: none"> Follow "ACTION" procedures of Right Mirror UP/DOWN, but use circuit numbers 541 (DB) in place of 544 (P).
<ul style="list-style-type: none"> Right Mirror operates properly; Left Mirror operates in UP/DOWN positions, but is inoperative in LEFT/RIGHT positions. 	<ul style="list-style-type: none"> No voltage at Left Mirror L/R Motor. Inoperative Power Mirror Switch. Inoperative motor assembly. 	<ul style="list-style-type: none"> Follow "ACTION" procedures of Right Mirror LEFT/RIGHT, but use circuit numbers 540 (R) in place of 543 (DG).

For further diagnostic information, refer to Section 01-09 of the Shop Manual.



BUY IT NOW!
Click Here To Order







RADIO

HOW THE CIRCUIT WORKS

With the Ignition Switch in ACC or RUN, voltage is applied through Fuse 11 to operate the Radio.

Fuse 8 applies voltage to the Radio, at all times, to power the memory-related functions, which retain clock and station pre-set information with the Radio turned off.

The Radio display brightness is controlled by the Instrument Panel Dimming Rheostat and the LCD Illumination Relay. During the day

when the park and headlamps are off, the LCD Illumination Relay is deenergized. Battery voltage is applied to the Radio through the 484 (O/BK) wire and the display is bright. When the park or headlamps are turned on, the LCD Illumination Relay is energized. A variable voltage is then applied to the Radio from the Instrument Panel Dimming Rheostat through the 484 (O/BK) wire to dim the display.

Premium Sound

The Premium Sound System feature incorporates a Radio with cassette deck and a four-channel Amplifier. Voltage is applied to the

Amplifier from Fuse 11 through the 137 (Y/BK) wire when the ignition is in RUN or ACC. Voltage is also applied to the Amplifier through the 747 (O/LB) wire to signal the Amplifier when the Radio is turned on. The Amplifier is grounded through the Radio and 694 (R) wire.

The Radio provides an audio signal for each channel through the 278 (P/W), 279 (W/R), 287 (BK/W), 277 (LB/BK) and 280 (LG) circuits. The Amplifier processes the audio signal provided by the Radio and supplies it to the individual speakers.

TROUBLESHOOTING HINTS

CONDITION	POSSIBLE CAUSE	ACTION
<ul style="list-style-type: none"> Radio display does not light, but Radio plays. 	<ul style="list-style-type: none"> No voltage to LCD Illumination Relay. Inoperative LCD Illumination Relay. Open 484 (O/BK) wire. Inoperative Radio. 	<ul style="list-style-type: none"> Check Fuse 6. With Ignition Switch in ACC or RUN, check for battery voltage on 296 (W/P) wire at LCD Illumination Relay. If battery voltage is not present, repair 296 (W/P) wire. If battery voltage is present, check for battery voltage on 484 (O/BK) wire at LCD Illumination Relay with Main Light Switch in OFF position. If battery voltage is not present on 484 (O/BK) wire, service LCD Illumination Relay. If battery voltage is present on 484 (O/BK) wire at LCD Illumination Relay, check for battery voltage on 484 (O/BK) wire at Radio connector C280. If battery voltage is not present on 484 (O/BK) wire at Radio, repair 484 (O/BK) wire. If battery voltage is present on 484 (O/BK) wire, remove Radio for service.



BUY IT NOW!
Click Here To Order



7-49 TROUBLESHOOTING/DESCRIPTIONS

SECTION 130 (cont'd)

TROUBLESHOOTING HINTS

CONDITION	POSSIBLE CAUSE	ACTION
<ul style="list-style-type: none"> Radio display lights but does not dim when lights are turned on. Instrument Panel lamps work normally. 	<ul style="list-style-type: none"> No voltage to LCD Illumination Relay. Inoperative LCD Illumination Relay. Open 484 (O/BK) wire. Inoperative Radio. 	<ul style="list-style-type: none"> With Main Light Switch in PARK or HEAD position, check for battery voltage on 14 (BR) wire at LCD Illumination Relay. If battery voltage is not present on 14 (BR) wire, repair 14 (BR) wire. If battery voltage is present on 14 (BR) wire, check for voltage on 19 (LB/R) wire at LCD Illumination Relay. Voltage should be from about 4 volts to 12 volts, depending on Instrument Panel Dimming Rheostat thumbwheel position. If voltage is not present, repair 19 (LB/R) wire. If voltage is present on 19 (LB/R) wire at LCD Illumination Relay, check for same voltage on 484 (O/BK) wire at LCD Illumination Relay. If voltage is not present, service LCD Illumination Relay. If voltage is present on 484 (O/BK) wire at LCD Illumination Relay, check for voltage on 484 (O/BK) wire at Radio. If voltage is not present at Radio, repair 484 (O/BK) wire. If voltage is present on 484 (O/BK) wire at Radio, remove Radio for service.
<ul style="list-style-type: none"> Radio doesn't appear to work; No sound from any Speaker; Radio display doesn't light. 	<ul style="list-style-type: none"> Blown Fuse. Open 137 (Y/BK) wire. Open 694 (R) wire. Antenna or cable. Inoperative Radio. 	<ul style="list-style-type: none"> Check Fuse 11. With ignition in ACC or RUN, check for battery voltage on 137 (Y/BK) wire at Radio connector C280. If battery voltage isn't present, repair 137 (Y/BK) wire. Check 694 (R) wire for continuity between connector C280 and ground. Check for clean and tight Antenna connections. Refer to Shop Manual, Section 35-10, for Antenna tests. Check for good connection at Radio connector. If all above checks are good, remove Radio for service.

100% SATISFACTION GUARANTEED

BUY IT NOW!

Click Here To Order

PayPal American Express Discover MasterCard VISA

TROUBLESHOOTING/DESCRIPTIONS 7-50

SECTION 130 (cont'd)

TROUBLESHOOTING HINTS

CONDITION	POSSIBLE CAUSE	ACTION
<ul style="list-style-type: none"> Radio doesn't appear to work; No sound from any Speaker; Radio display lights. 	<ul style="list-style-type: none"> Antenna or cable. Loss of power or ground to Amplifier (Premium Sound only) or graphic equalizer (if equipped). 	<ul style="list-style-type: none"> Check Antenna and Antenna cable for clean and tight connections. Refer to Shop Manual, Section 35-10, for Antenna tests. With ignition in ACC or RUN, check for battery voltage on 137 (Y/BK) wire at Amplifier and Graphic Equalizer. With Radio ON, check for battery voltage on 747 (O/LB) wire at Amplifier. Check for continuity to ground in 694 (R) wire. If battery voltage is measured at 137 (Y/BK) and 747 (O/LB) and ground is good, remove Amplifier and Graphic Equalizer for service.
<ul style="list-style-type: none"> One Speaker doesn't work. 	<ul style="list-style-type: none"> Open Speaker. Open or shorted Speaker leads. 	<ul style="list-style-type: none"> Disconnect Speaker leads from Radio. Connect an analog ohmmeter across suspect Speaker terminals. If Speaker pops, Speaker is OK. Check for short or open on wires that are connected to that particular Speaker. If all connections and wires are OK, remove Radio for service.
<ul style="list-style-type: none"> LCD Display is erratic. 	<ul style="list-style-type: none"> Low voltage to Radio. 	<ul style="list-style-type: none"> Check 54 (LG/Y) wire for 12 volts. If less than 12 volts, check Battery.
<ul style="list-style-type: none"> AM works; FM doesn't. 	<ul style="list-style-type: none"> Inoperative Radio. 	<ul style="list-style-type: none"> Compare to a known good radio for FM operations. If Radio does not work as well, remove Radio for service.
<ul style="list-style-type: none"> FM works; AM doesn't. 	<ul style="list-style-type: none"> Inoperative Antenna or Antenna cable. Inoperative Radio. 	<ul style="list-style-type: none"> Check Radio with a test Antenna. If reception improves, check/repair Antenna. If reception does not improve, remove Radio for service.
<ul style="list-style-type: none"> Tape Deck sounds distorted or doesn't work. 	<ul style="list-style-type: none"> Foreign materials in Tape Deck. Dirty Tape Deck heads. 	<ul style="list-style-type: none"> Remove foreign materials and/or clean Tape Deck heads.

For further diagnostic information, refer to Section 15 of the Shop Manual.



BUY IT NOW!
Click Here To Order



10-1 GROUNDS

Refer to page 7-1 for Troubleshooting/Descriptions.

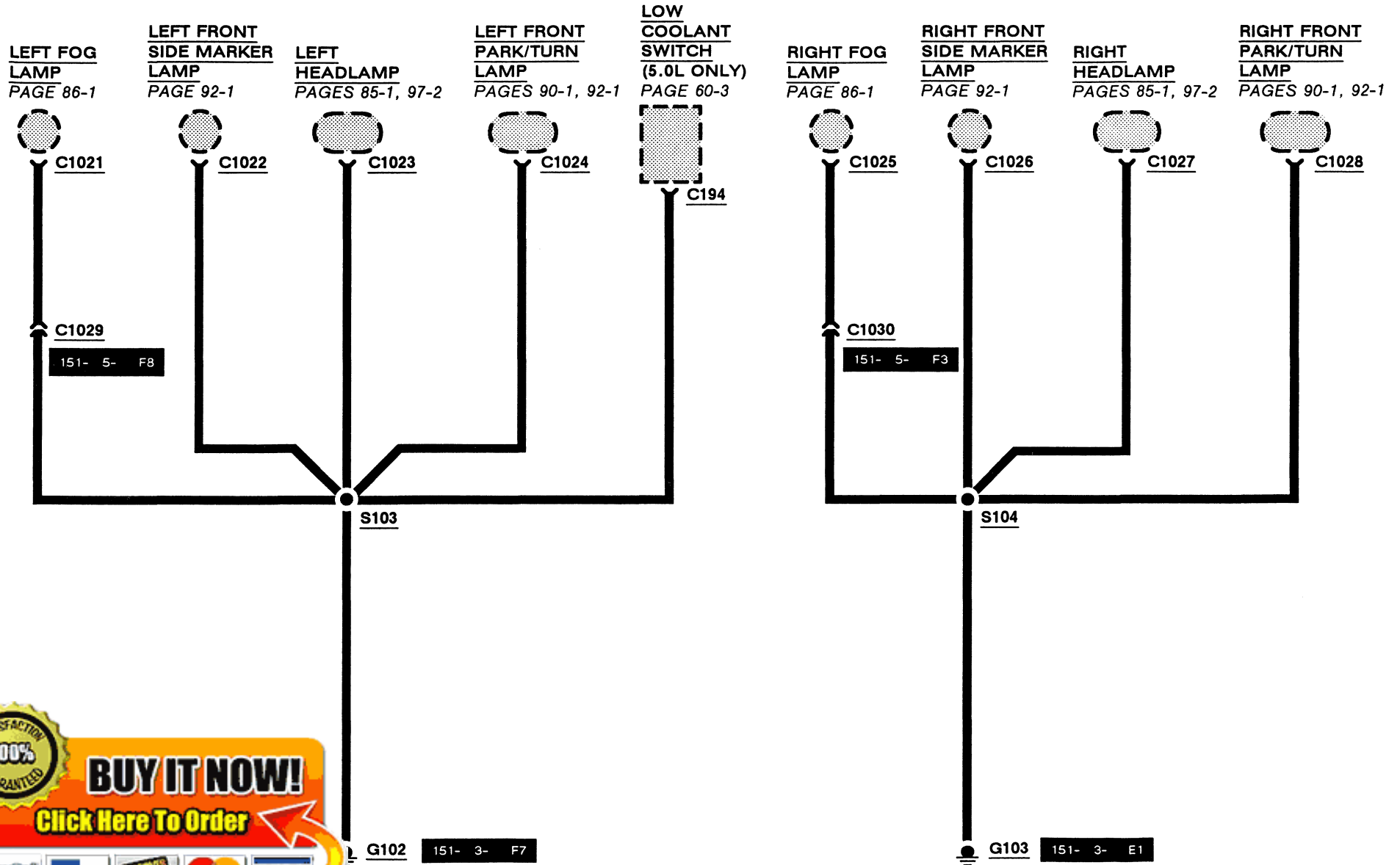

100% SATISFACTION GUARANTEED

BUY IT NOW!

Click Here To Order

PayPal

Discover Cards

AMERICAN EXPRESS

MasterCard

VISA

AIR BAG
DIAGNOSTIC
MODULE
PAGE 46-1

SHIFT LOCK
ACTUATOR
PAGE 37-1

BLOWER
MOTOR
SWITCH
PAGES 53-2,
54-2, 54-4

BLOWER
MOTOR
RESISTOR
ASSEMBLY
PAGES 53-2,
54-2, 54-4

(NOT USED)

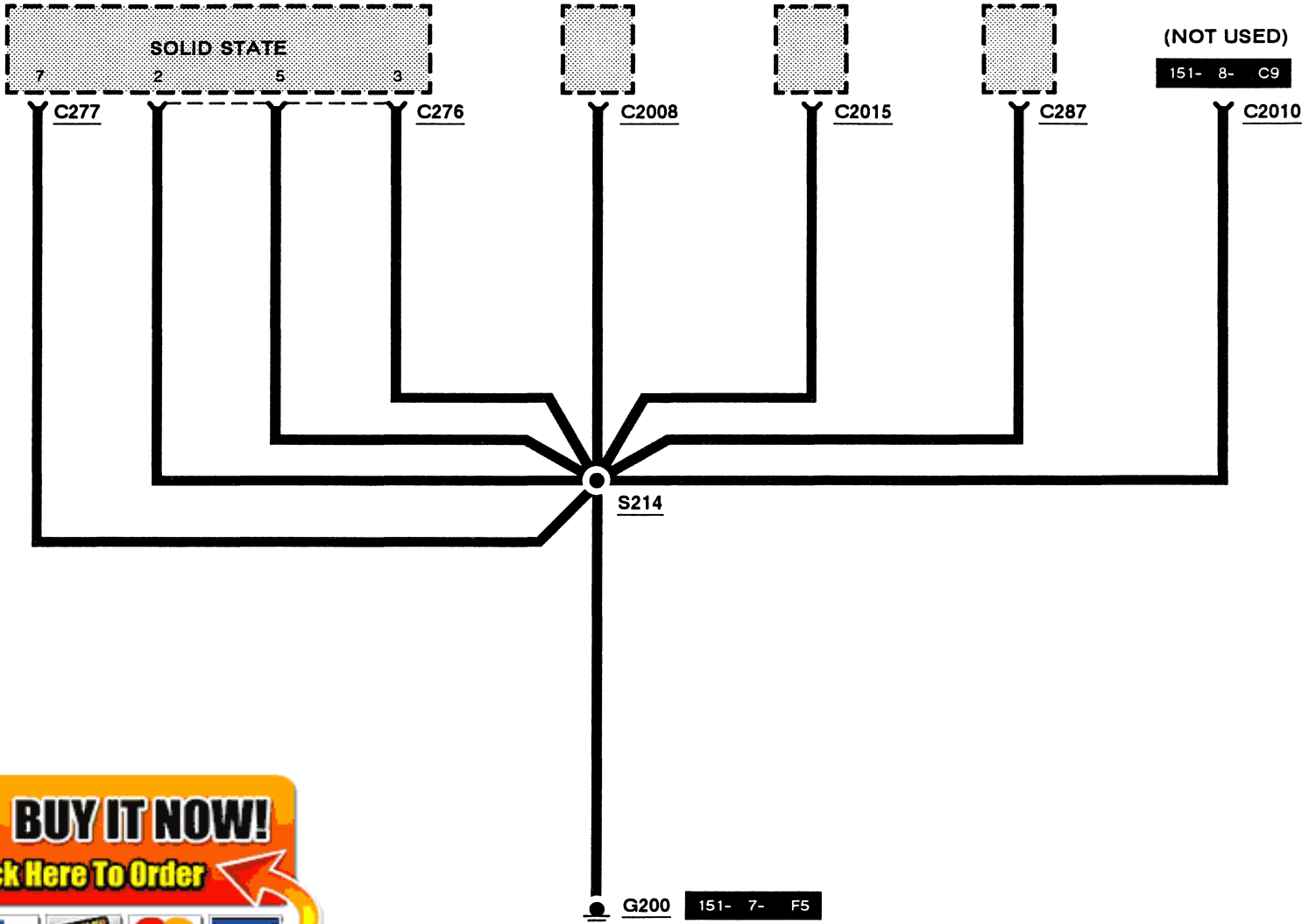

100% SATISFACTION GUARANTEED

BUY IT NOW!

Click Here To Order

10-3 GROUNDS

2.3L

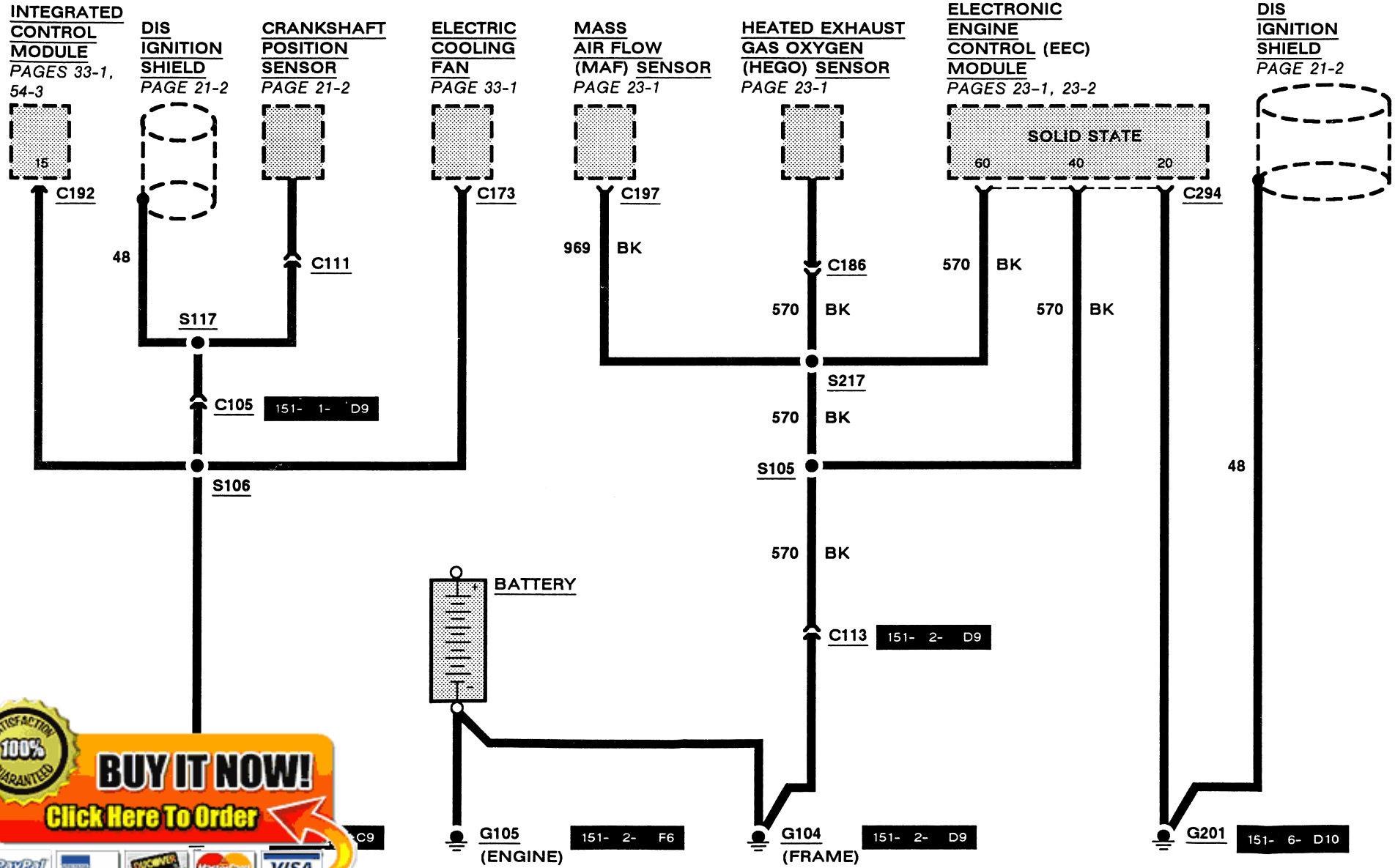

100% SATISFACTION GUARANTEED

BUY IT NOW!

Click Here To Order

5.0L

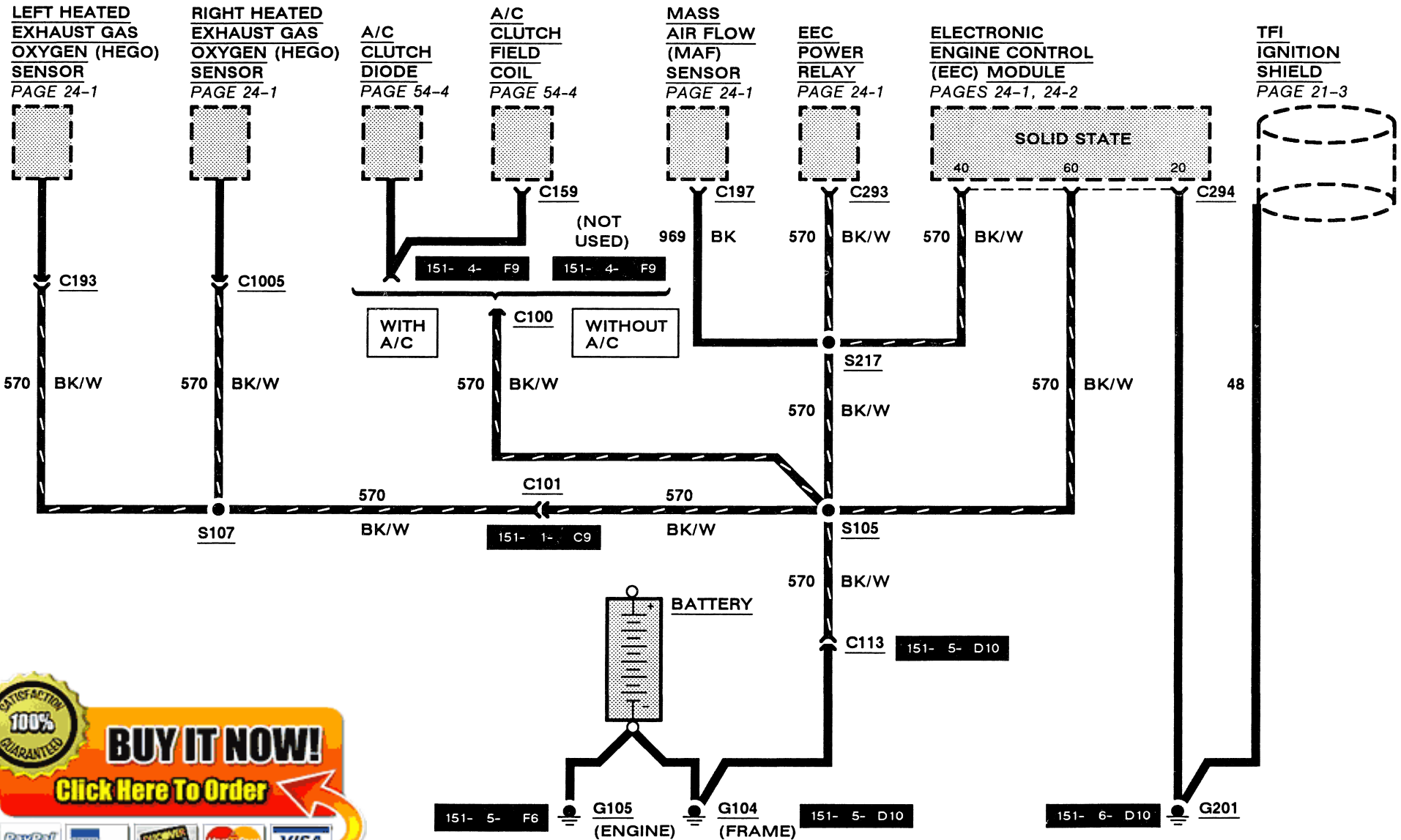

100% SATISFACTION GUARANTEED

BUY IT NOW!

Click Here To Order

PayPal, American Express, Discover, MasterCard, VISA

10-5 GROUNDS

ELECTRONIC ENGINE CONTROL (EEC) MODULE
PAGES 23-1, 24-2

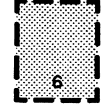

C294
676 PK/O

C213
151- 6- C10

676 PK/O

VEHICLE SPEED SENSOR (VSS)
PAGE 64-1

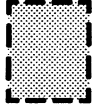

C1016
563 O/Y

C212
151- 6- D1

676 PK/O

5.0L ONLY

LOW OIL WARNING RELAY
PAGE 60-3

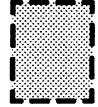

C196

SPEED CONTROL AMPLIFIER
PAGE 31-1

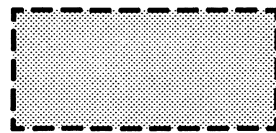

676 PK/O
C215

REAR WINDOW DEFROST CONTROL RELAY
PAGE 56-1

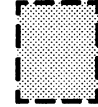

C2007

MAIN LIGHT SWITCH
PAGE 13-11



C2005

INTERVAL GOVERNOR
PAGE 81-1

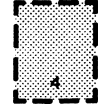

C2002

INSTRUMENT CLUSTER
PAGES 60-1, 60-2

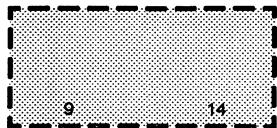

C251

C250

ENGINE COMPARTMENT LAMP
PAGE 89-1



C158

C102 151- 3- A9

S216

S100

G100

151- 2- C9

100% SATISFACTION GUARANTEED

BUY IT NOW!

Click Here To Order

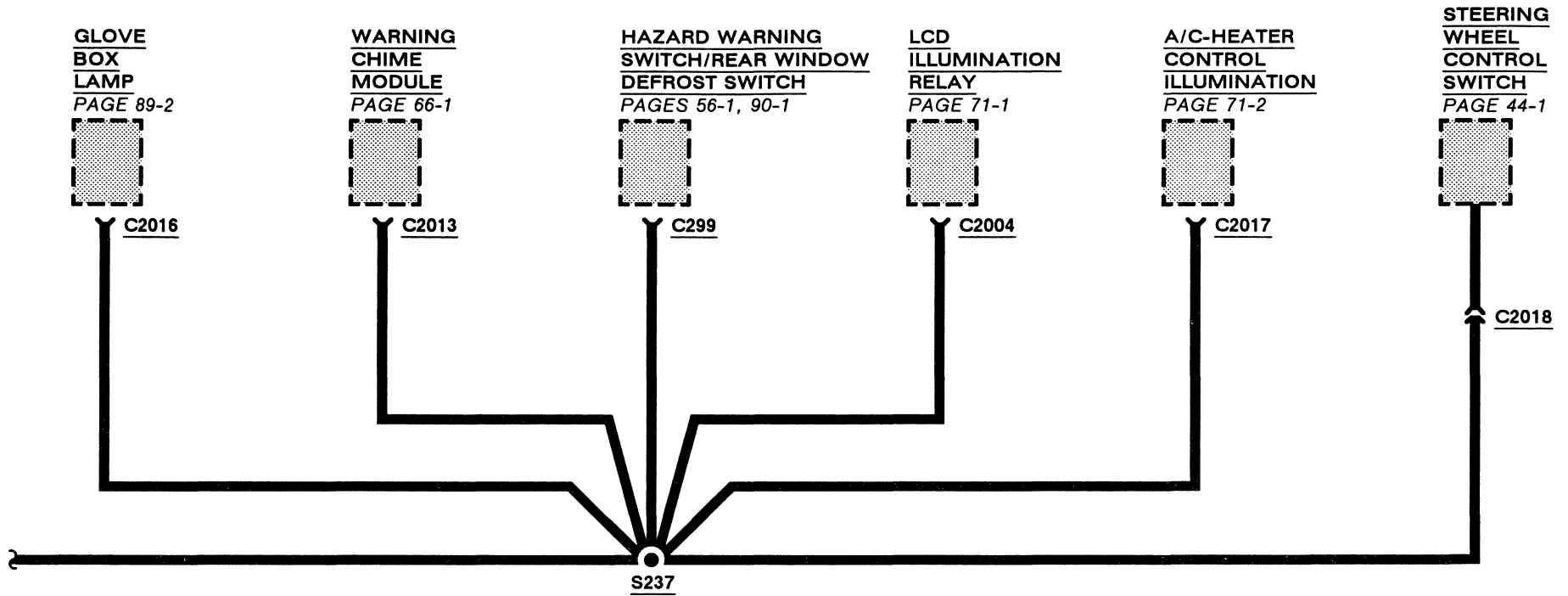

WINDSHIELD WASHER PUMP MOTOR
PAGE 81-1

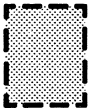

C1018

WINDSHIELD WIPER MOTOR
PAGE 81-1

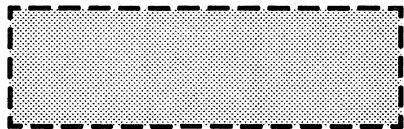

C152

C151

BRAKE FLUID LEVEL SWITCH
PAGES 60-3, 97-1

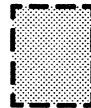

C164

100% SATISFACTION GUARANTEED

BUY IT NOW!

Click Here To Order

10-7 GROUNDS

2 AND 3 DOOR

WITH POWER WINDOWS

MASTER WINDOW/
DOOR LOCK
CONTROL SWITCH
PAGES 100-3, 110-1

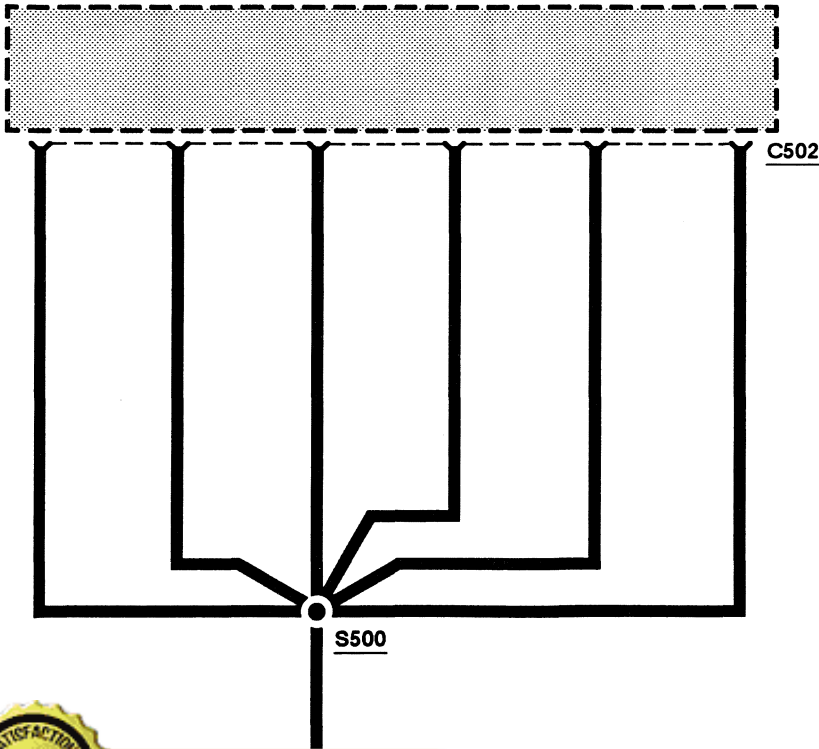

WITHOUT POWER WINDOWS

LEFT DOOR
LOCK SWITCH
PAGE 110-2

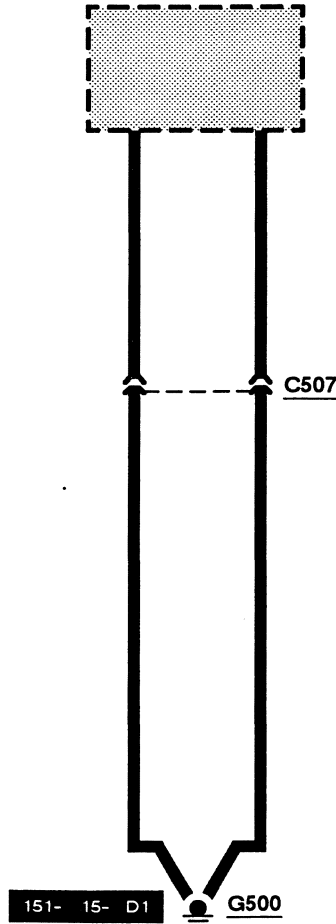

CONVERTIBLE

MASTER WINDOW/
DOOR LOCK
CONTROL SWITCH
PAGES 100-1, 110-3

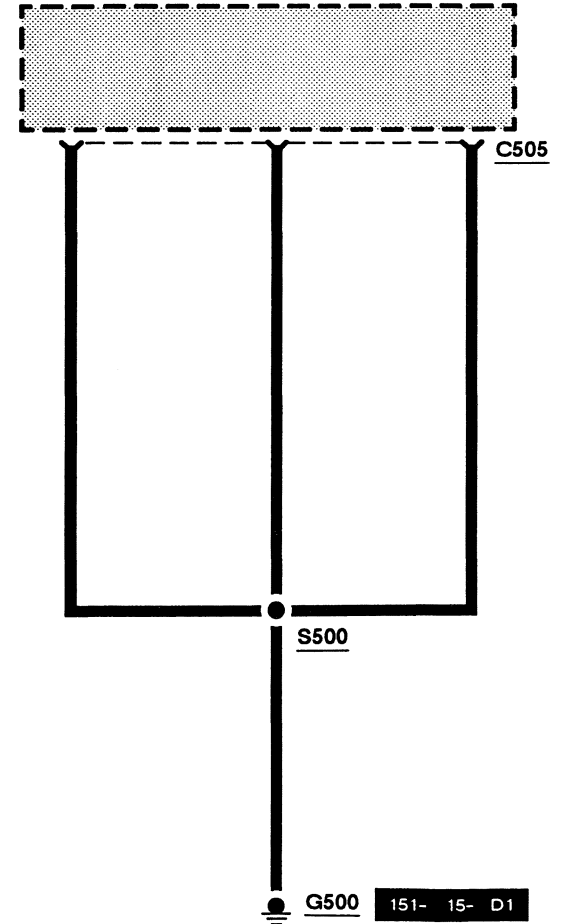

100% SATISFACTION GUARANTEED

BUY IT NOW!

Click Here To Order

5- D1

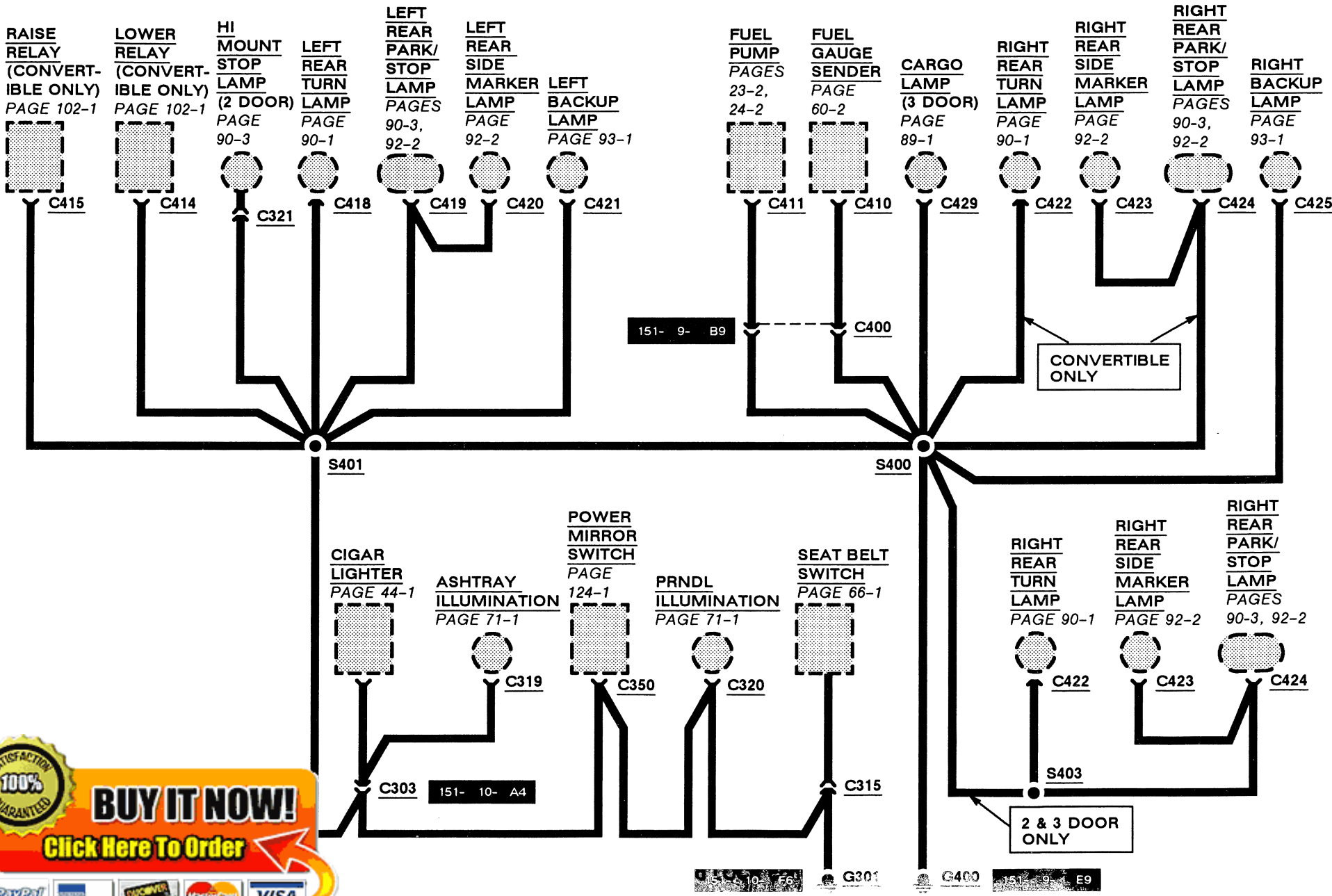

100% SATISFACTION GUARANTEED

BUY IT NOW!

Click Here To Order

10-9 GROUNDS

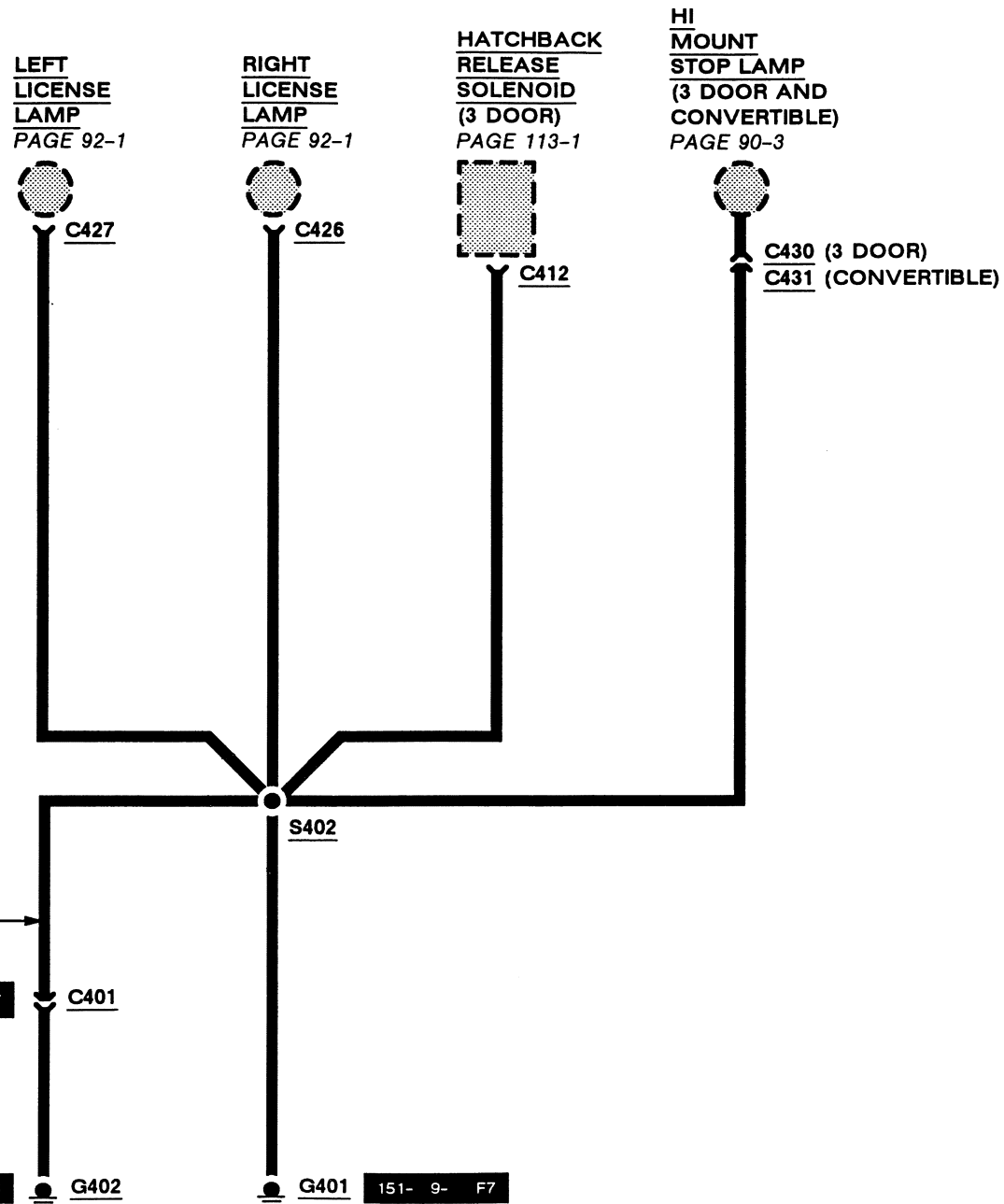

100% SATISFACTION GUARANTEED

BUY IT NOW!

Click Here To Order

PayPal, American Express, Discover, MasterCard, VISA

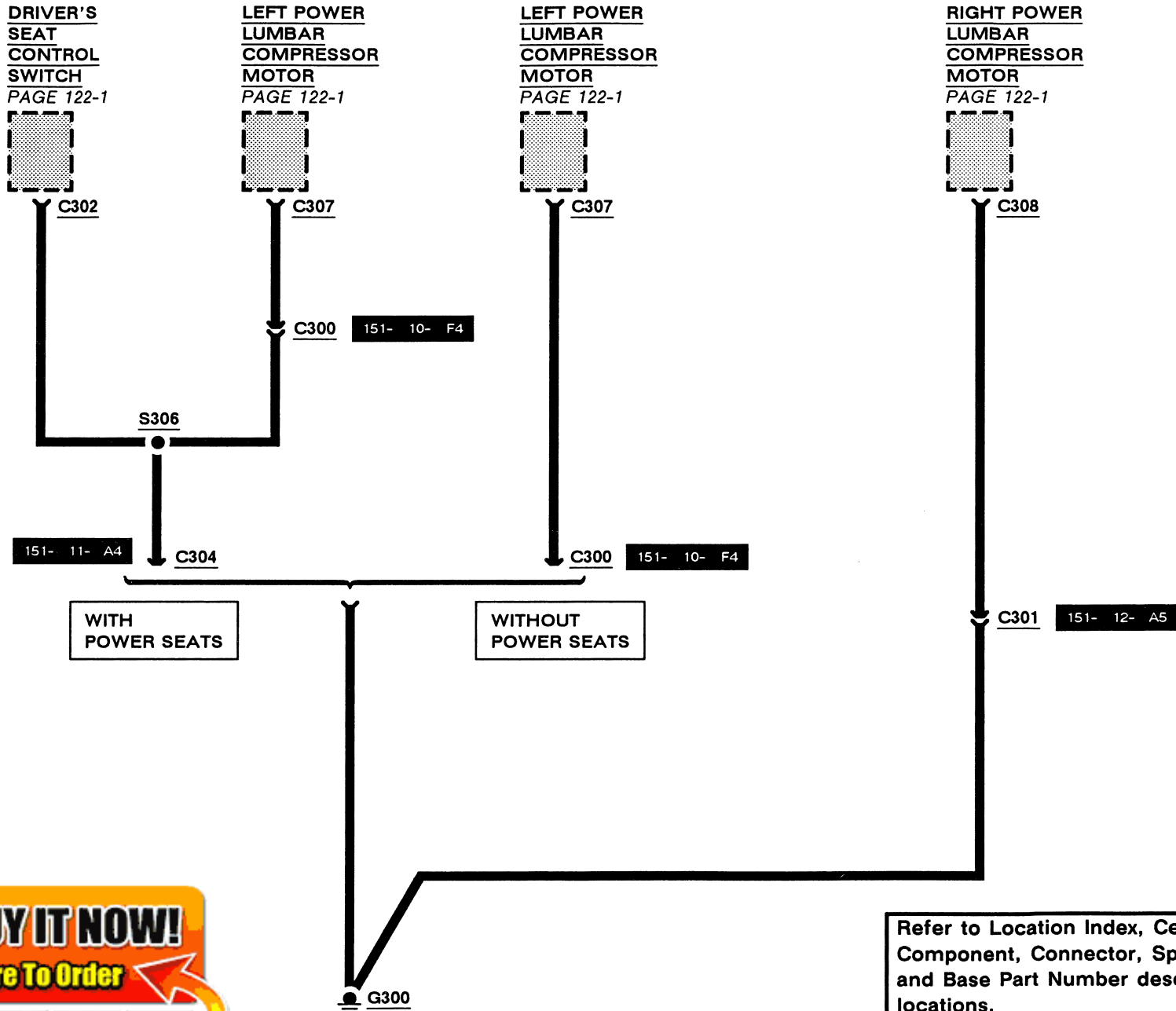

Refer to Location Index, Cell 152, for Component, Connector, Splice, Ground and Base Part Number descriptions and locations.

100% SATISFACTION GUARANTEED

BUY IT NOW!

Click Here To Order

PayPal, American Express, Discover, MasterCard, VISA

11-1 CIRCUIT PROTECTION/FUSE PANEL

CIRCUIT PROTECTION DEVICES

Electrical circuits on this vehicle may be protected by fuses, fusible links, maxi-fuse cartridges, circuit breakers, or a combination of these devices.

BLADE TYPE FUSE

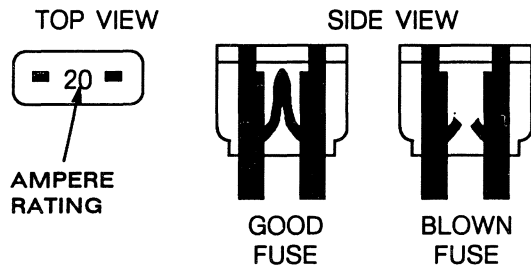

Blade type fuses have a transparent plastic housing. To check a fuse, pull it from the fuse panel and look at the fuse element through the housing. Always replace a blown fuse with a new fuse that has the same ampere rating.

The ampere rating of a blade type fuse can also be determined by following the color code shown here:

BLADE FUSE COLOR CODING	
AMPERE RATING	HOUSING COLOR
4	Pink
5	Tan
10	Red
15	Light Blue

100% SATISFACTION GUARANTEED

BUY IT NOW!

Click Here To Order

FUSIBLE LINK

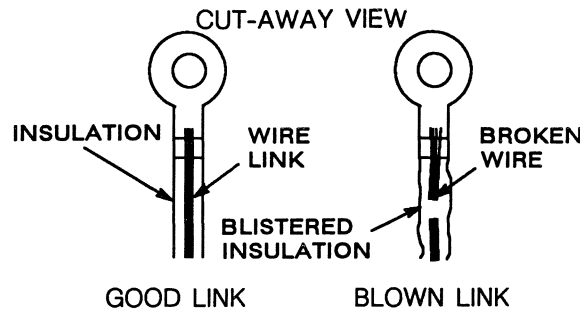

Fusible links are short lengths of wire that are smaller in diameter than the wires they are protecting. Fusible link wire is covered with a special thick, non-flammable insulation. An overload condition causes the insulation to blister. If the overload condition continues, the wire link will melt. To check a fusible link, look for blistered insulation. If the insulation is okay, pull lightly on the wire; if the fusible link stretches, the wire has melted.

When replacing fusible links, first cut the protected wire where it is connected to the fusible link. Then, tightly crimp or solder the new link to the protected wire.

Fusible links are often identified by color coding of the insulation, as shown here:

FUSIBLE LINK COLOR CODING	
WIRE LINK SIZE	INSULATION COLOR
20 GA	Blue
18 GA	Brown or Red
16 GA	Black or Orange
14 GA	Green
12 GA	Gray

MAXI-FUSE CARTRIDGE

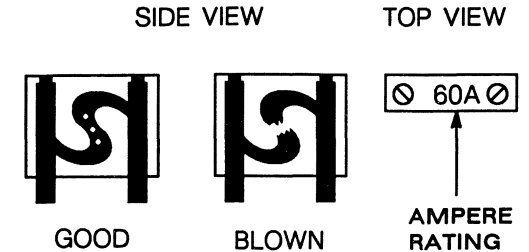

Maxi-fuse cartridges have a transparent colored plastic housing. To check a maxi-fuse cartridge, look at the fuse element through the side of the housing.

To replace a maxi-fuse cartridge, pull it from the fuse box or panel. Always replace a blown maxi-fuse cartridge with a new one having the same ampere rating.

The ampere rating of a maxi-fuse cartridge can also be determined by following the color code shown here:

FUSIBLE LINK CARTRIDGE COLOR CODING	
AMPERE RATING	HOUSING COLOR
30	Light Green
40	Amber
50	Red
60	Blue

CIRCUIT PROTECTION/FUSE PANEL 11-2

CIRCUIT BREAKER

Some circuits are protected by circuit breakers (abbreviated "c. b." in fuse chart). They can be Fuse Panel mounted or in-line. Like fuses, they are rated in amperes.

Each circuit breaker conducts current through an arm made of two types of metal bonded together (bimetal arm). If the arm starts to carry too much current, it heats up. As one metal expands faster than the other the arm bends, opening the contacts. Current flow is broken. A circuit breaker can be the cycling or non-cycling type.

FUSE PANEL MOUNTED CYCLING TYPE

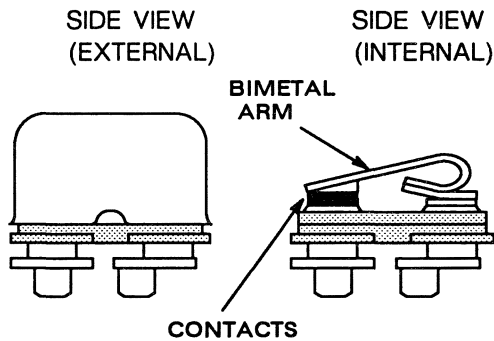

IN-LINE MOUNTED CYCLING TYPE

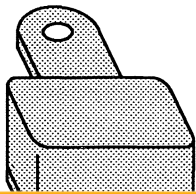

In the cycling type, the bimetal arm cools and straightens out. This cycle repeats as long as the overcurrent exists and power is applied.

FUSE PANEL MOUNTED NON-CYCLING TYPE

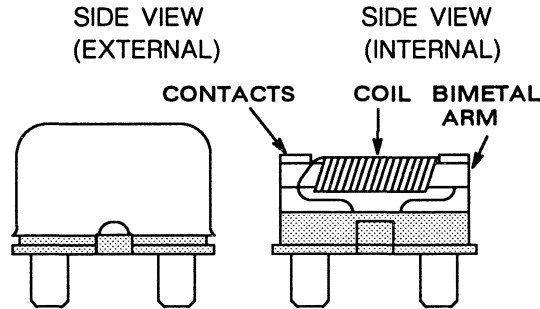

FUSE PANEL MOUNTED MANUAL RESET TYPE

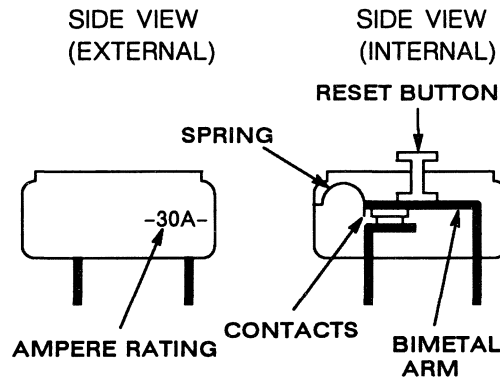

Two types of non-cycling circuit breakers are used; one is reset by removing power from the circuit, and the other is reset by depressing a reset button.

In the first type, there is a coil wrapped around the bimetal arm. When an overcurrent exists and the contacts open, a small current passes through the coil. This current through the coil is not enough to operate a load, but it does heat up both the coil and the bi-metal arm. This keeps the arm in the open position until power is removed.

In the second type, a spring pushes the bi-metal arm down and holds the contacts together. When an overcurrent condition exists and the bimetal arm heats up, the bimetal arm bends enough to overcome the spring and the contacts snap open. The contacts stay open until the reset button is pushed and the contacts snap together again.



Diodes are electrical devices that permit current to flow in one direction only. The current flows in the direction indicated by the arrow.

100% SATISFACTION GUARANTEED

BUY IT NOW!

Click Here To Order

11-3 CIRCUIT PROTECTION/FUSE PANEL

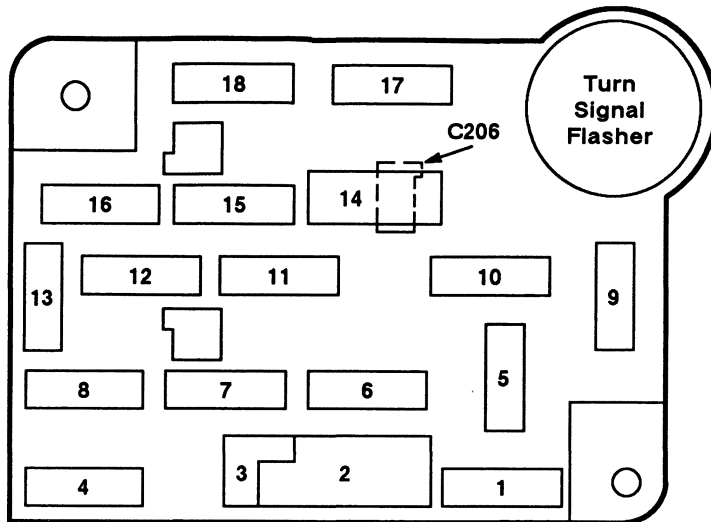

Fuse Value Amps	Color Code
4	Pink
5	Tan
10	Red
15	Light Blue
20	Yellow
25	Natural
30	Light Green

Power Distribution

The Alternator and Battery are connected together at the Starter Relay hot terminal. Other circuits originate at the Starter Relay hot terminal and are protected by fuse links. Low power circuits are also protected by fuses.

Fuse Position	Amps	Circuits Protected
1	15	Stop/Hazard Lamps, Speed Control, Shift Lock
2	15	Interval Wiper/Washer
3	—	(Not Used)
4	15	Exterior Lamps, Instrument Illumination, Warning Chime
5	15	Turn Signals, Backup Lamps, Rear Window Defrost, Convertible Top, Daytime Running Lamps (DRL), Shift Lock
6	20	Instrument Illumination, A/C-Heater, Trunk Lid Release, Speed Control
7	15	Air Bag Restraint System
8	15	Courtesy Lamps, Radio, Warning Chime, Power Mirror
9	30	A/C-Heater
10	20	Flash-to-Pass, Daytime Running Lamps (DRL)
11	15	Radio
12	15	Convertible Top
13	5	Instrument Illumination
14	20 c.b.	Power Windows
15	15	Fog Lamps
16	20	Cigar Lighter, Horn
17	—	(Not Used)
18	15	Instrument Cluster, Air Bag Restraint System, Warning Chime, Low Oil Level Warning Relay

ump Switch are powered at all 12 and 16. The other fuses are at the Main Light Switch.

100% SATISFACTION GUARANTEED

BUY IT NOW!

Click Here To Order

12-1 CHARGING SYSTEM

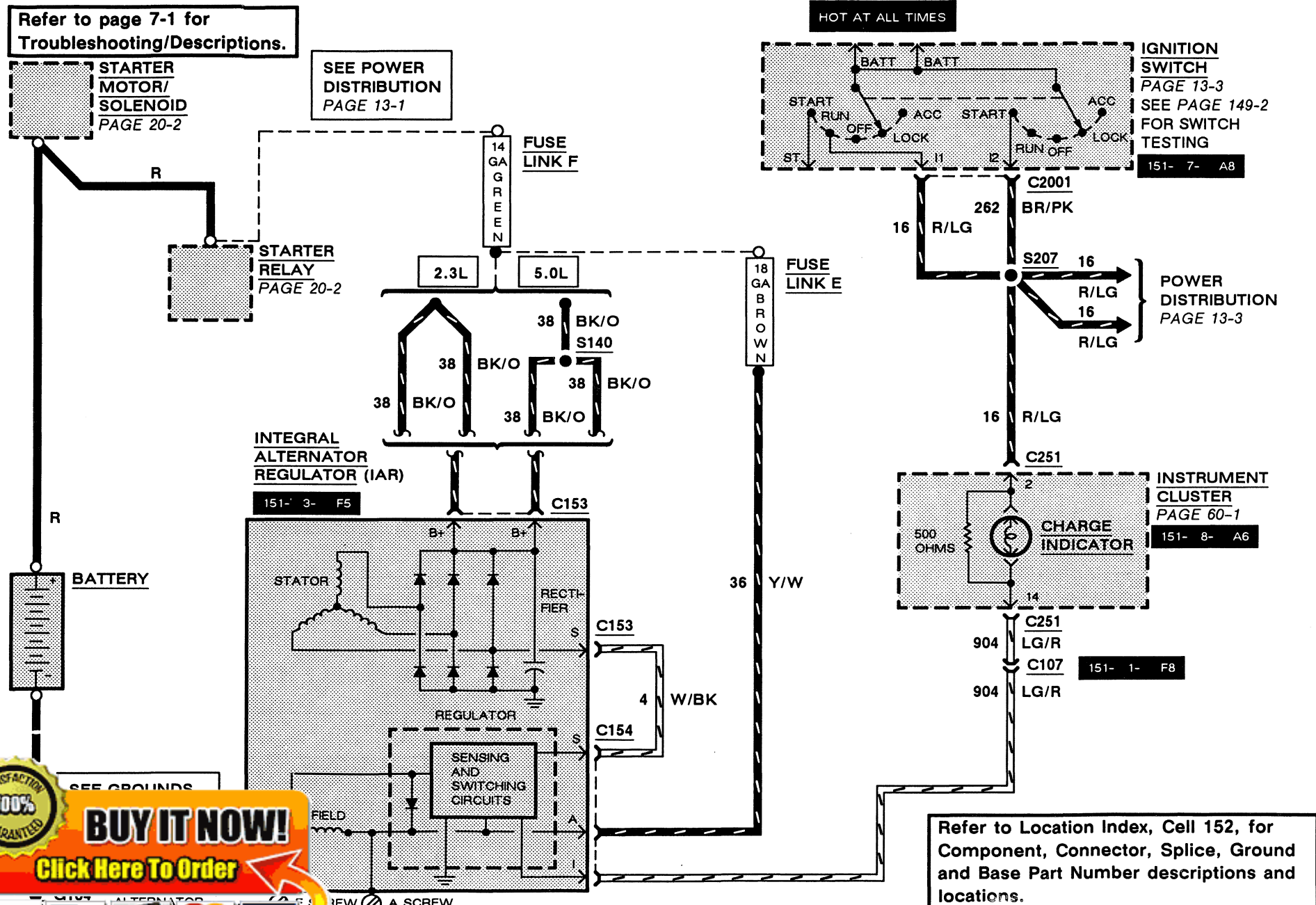

Refer to Location Index, Cell 152, for Component, Connector, Splice, Ground and Base Part Number descriptions and locations.

100% SATISFACTION GUARANTEED

BUY IT NOW!

Click Here To Order

SEE GROUNDS

ALTERNATOR

SCREW A SCREW

PayPal, American Express, Discover, MasterCard, VISA

100% SATISFACTION GUARANTEED

BUY IT NOW!

Click Here To Order

PayPal American Express Cards Discover NOW! MasterCard VISA

13-1 POWER DISTRIBUTION

Refer to page 7-2 for Troubleshooting/Descriptions.

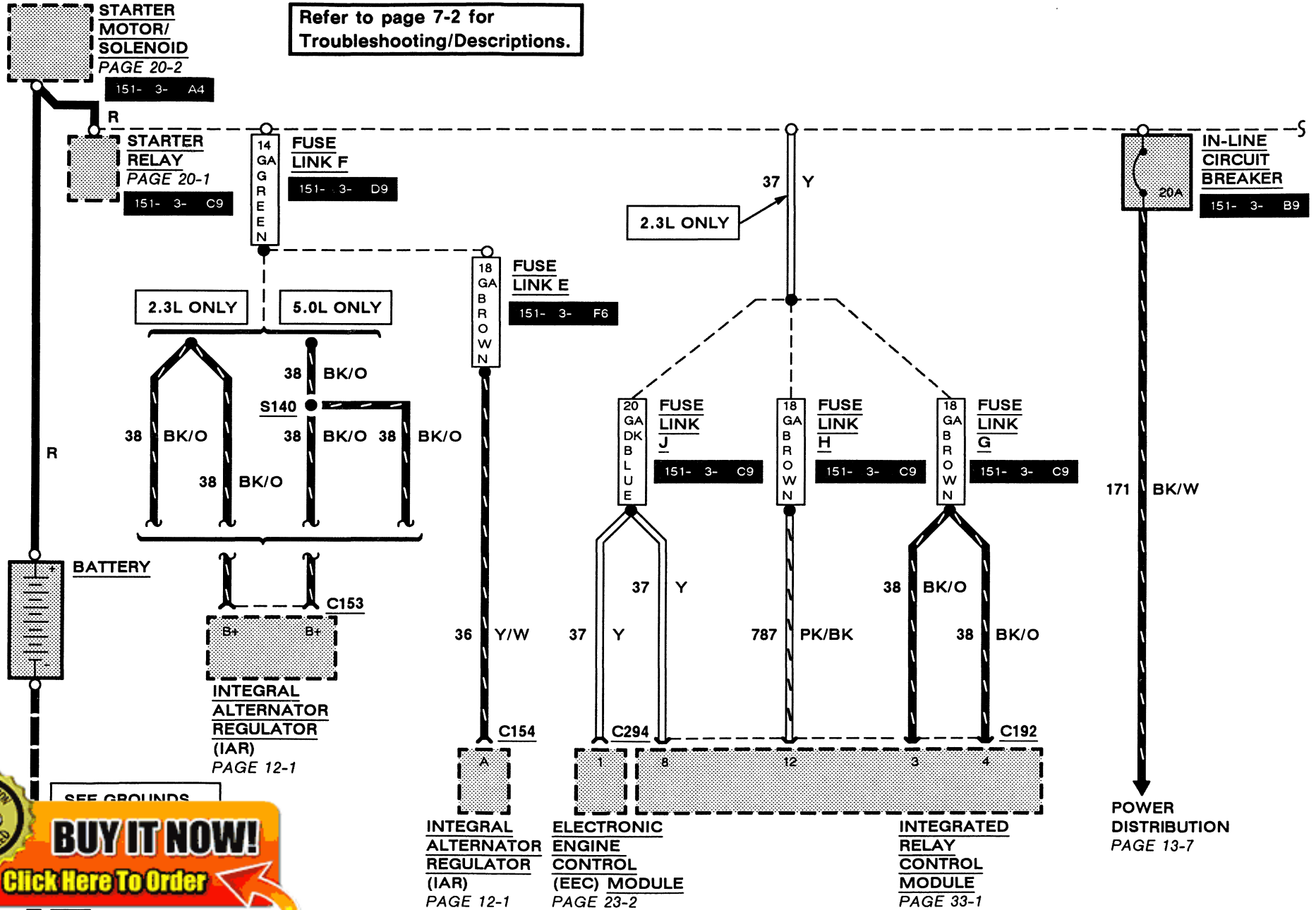

100% SATISFACTION GUARANTEED

BUY IT NOW!

[Click Here To Order](#)

PayPal | American Express | Discover | MasterCard | VISA

COMPONENT LOCATION VIEWS 151-12

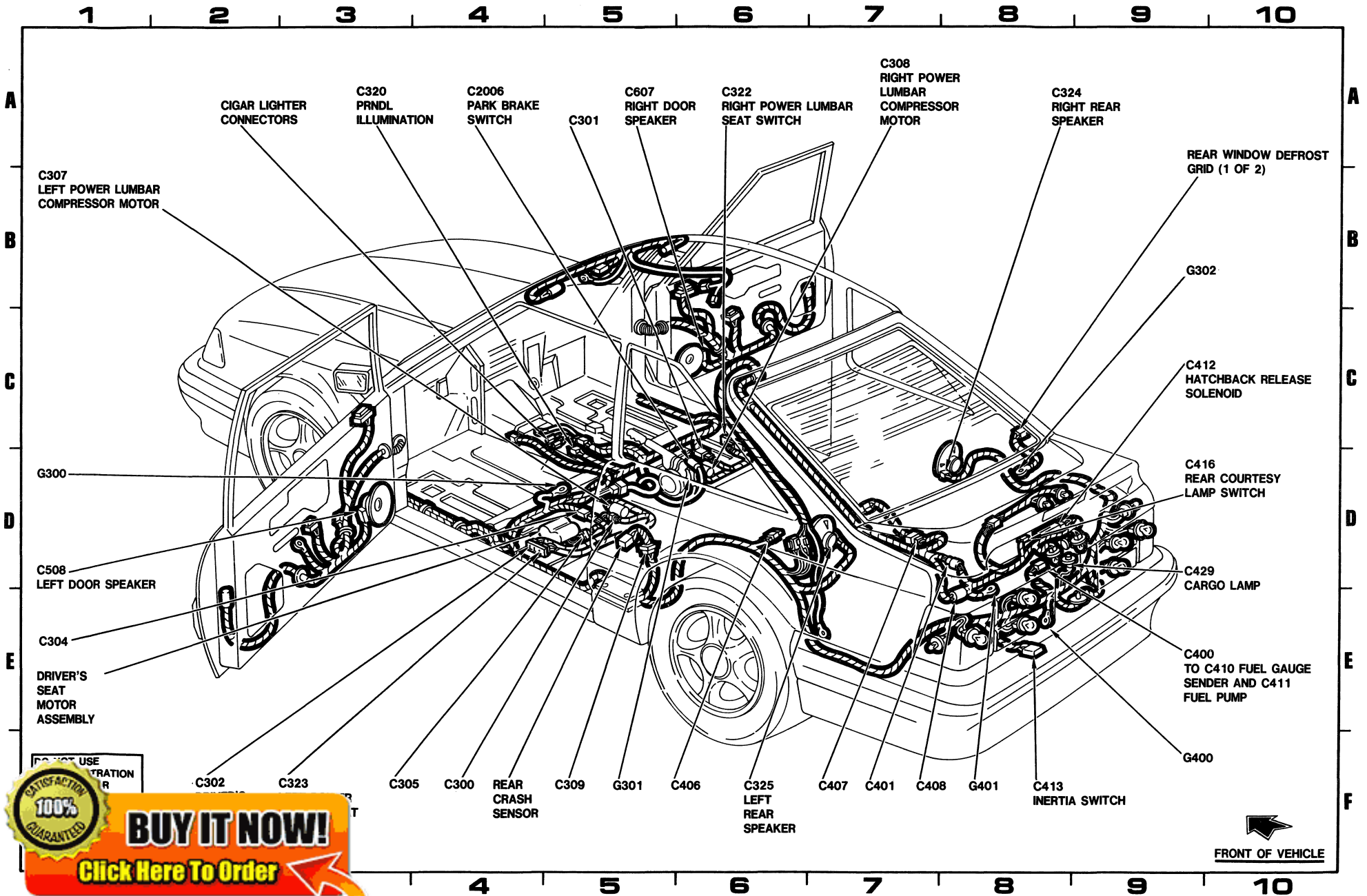

FRONT OF VEHICLE

FULL BODY VIEW (3 DOOR) (1 OF 2)

DO NOT USE FOR IDENTIFICATION

100% SATISFACTION GUARANTEED

BUY IT NOW!

[Click Here To Order](#)

COMPONENT LOCATION VIEWS 151-14

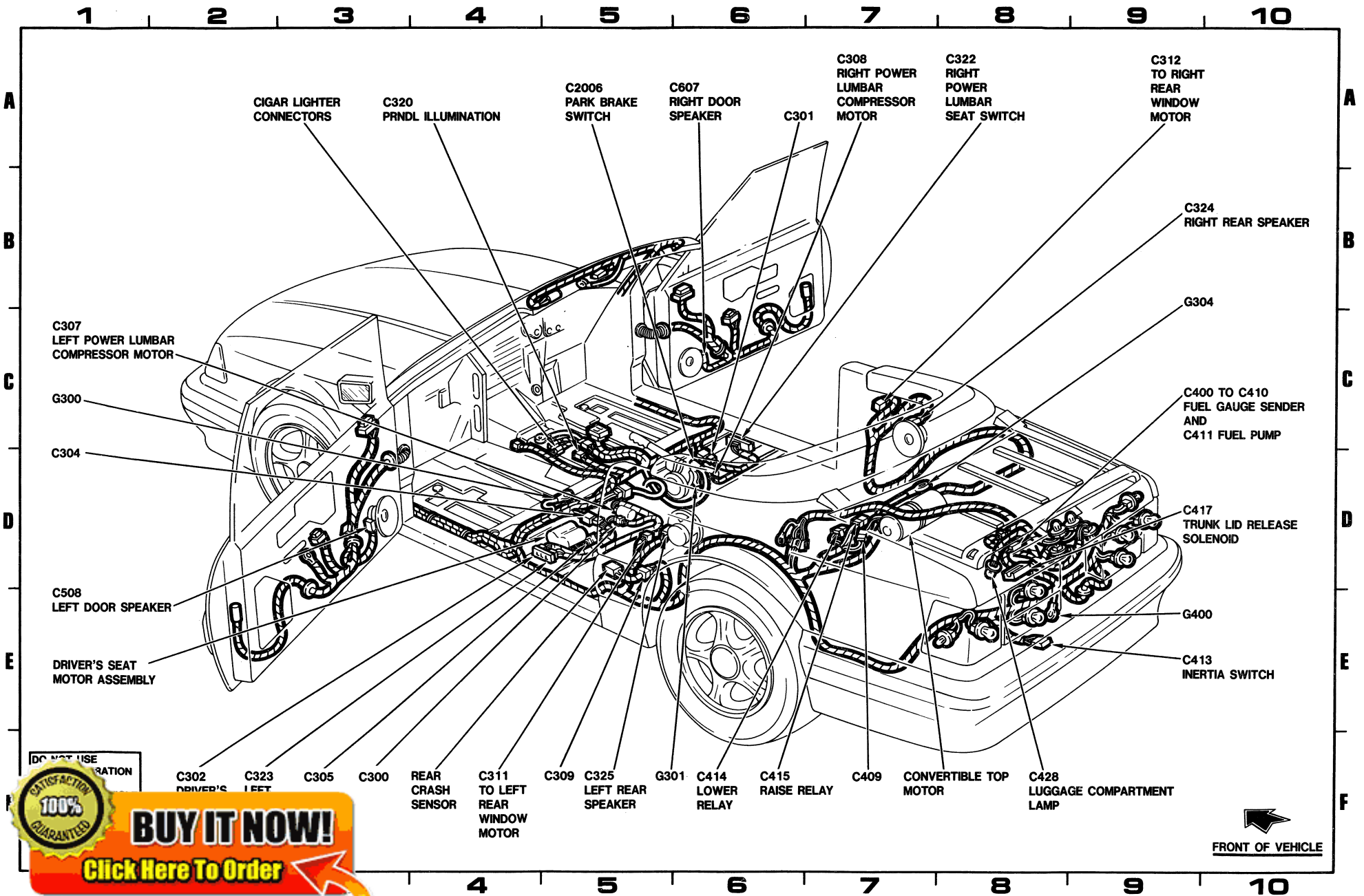

FULL BODY VIEW (CONVERTIBLE) (1 OF 2)

DO NOT USE
EXTRACTION

100% SATISFACTION GUARANTEED

BUY IT NOW!

[Click Here To Order](#)

PayPal American Express Cards Discover Rewards MasterCard VISA

151-15 COMPONENT LOCATION VIEWS

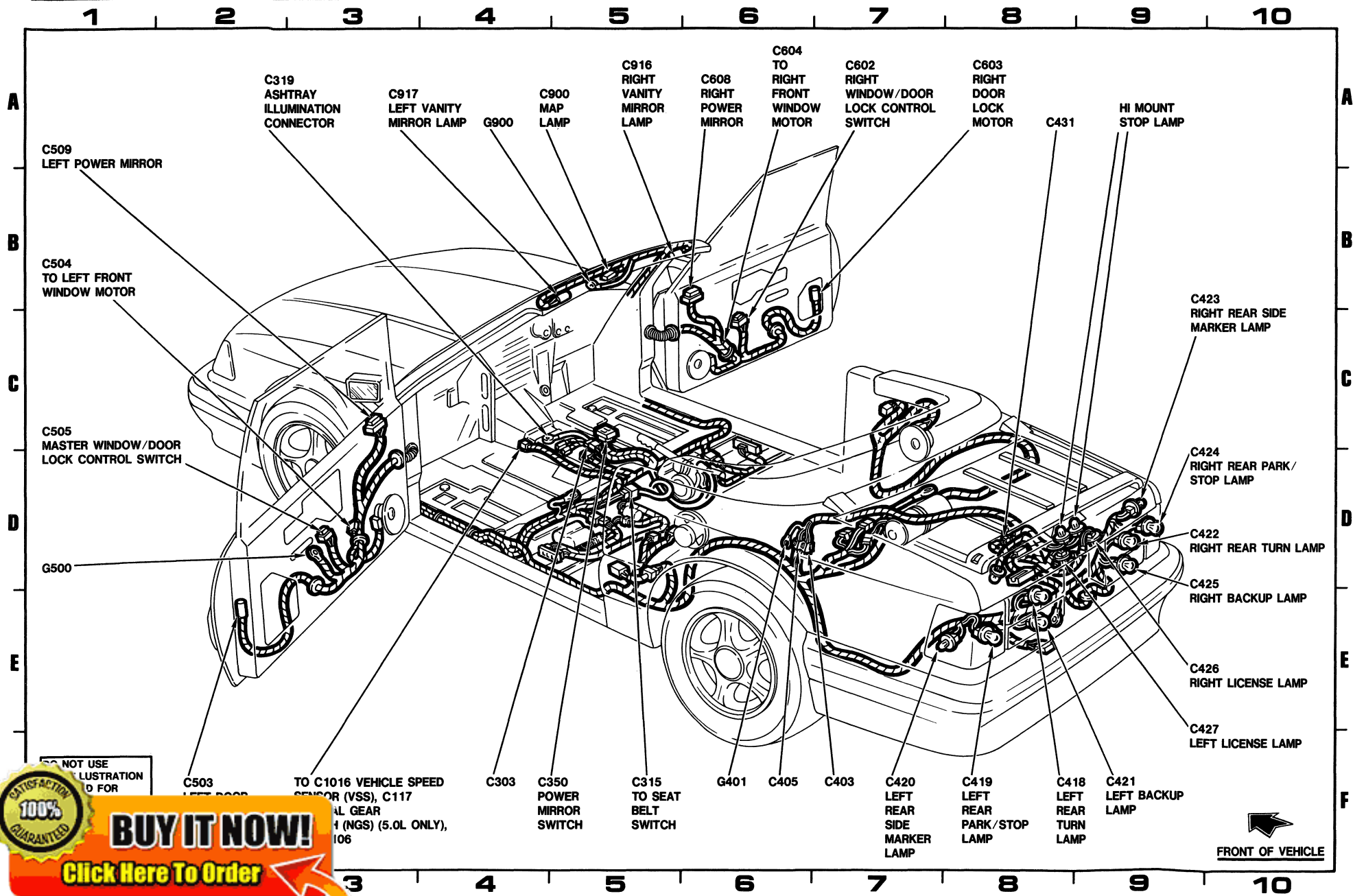

FULL BODY VIEW (CONVERTIBLE) (2 OF 2)

100% SATISFACTION GUARANTEED

BUY IT NOW!

Click Here To Order

PayPal, American Express, Discover, MasterCard, VISA

152-1 LOCATION INDEX

Base Harness Number	Harness Name	Major System
7C078	Transmission Control Neutral Switch	Backup Lamps Starting System
7E443	Transmission Control Switch	Speed Control Vehicle Speed Sensor
9A340	Fuel Pump Feed Jumper	Fuel Pump Instrument Cluster (Fuel Gauge)
9D821	Speed Control Connector	Speed Control
9D930	Fuel Charging	Electronic Engine Control
12A581	Engine Control Sensor	Air Conditioner Air Bag Restraint Cooling Fans Electronic Engine Control Heater Ignition System Starting System
12A690	Engine Control Sensor Extension	Electronic Engine Control Ignition System
12638	Starter Circuit Jumper	Starting System
13412	Rear License Lamp	Courtesy Lamps Exterior Lamps Trunk Lid Release Turn/Stop/Hazard Lamps
13B440	Rear License Lamp Feed	License Lamp Rear Window Defrost
14024	Front Door Lock (RH)	Radio Power Door Locks Power Mirrors
14025	Front Door Lock (LH)	Power Door Locks Power Mirrors Radio
	Dash Panel To Headlamps	Charging System Exterior Lamps Fog Lamps Headlamps Horns Starting System Turn/Stop/Hazard Lamps Courtesy Lamps

100% SATISFACTION GUARANTEED

BUY IT NOW!

Click Here To Order

PayPal American Express Discover MasterCard VISA

LOCATION INDEX 152-2

<u>Base Harness Number</u>	<u>Harness Name</u>	<u>Major System</u>
14335	Interior Lamp	Courtesy Lamps
14401	Main	Air Conditioner/Heater
		Air Bag Restraint
		Convertible Top
		Daytime Running Lamps
		Fog Lamps
		Fuse Panel
		Headlamps
		Horn
		Ignition System
		Instrument Cluster
		Instrument Illumination
		Interval Wiper/Washer
		Radio
		Rear Window Defrost
		Speed Control
		Starting System
		Turn/Stop/Hazard Lamps
		Warning Chime
14405	Rear Lamps	Air Bag Restraint
		Backup Lamps
		Courtesy Lamps
		Convertible Top
		Exterior Lamps
		Fuel Pump Inertia Switch
		Fuel Pump Relay
		Instrument Illumination
		Power Mirrors
		Power Windows
		Radio
		Rear Window Defrost
		Turn/Stop/Hazard Lamps
	Regulator	Power Door Locks
		Power Mirrors
		Power Windows
		Radio
	Regulator	Power Door Locks
		Power Mirrors
		Power Windows

100% SATISFACTION GUARANTEED

BUY IT NOW!

Click Here To Order

PayPal American Express Discover MasterCard VISA

152-3 LOCATION INDEX

<u>Base Harness Number</u>	<u>Harness Name</u>	<u>Major System</u>
14631	Left Front Window Regulator (cont'd)	Radio
14A200	Window Regulator Relay Switch	Power Windows
14A318	Accessory Feed	Ashtray Illumination Cigar Lighter
14B084	Seat Back Pad Adjust	Lumbar Seats
15525	Backup Lp Sw To Rear Lamp Feed	Backup Lamps
15A702	Engine Compartment Lamp Feed	Courtesy Lamps
18B864	Radio Power Booster and Equalizer Amplifier	Radio
18C618	Back Window Heater	Rear Window Defrost
18C619	Back Window Heater	Rear Window Defrost
18C620	Back Window Ground	Rear Window Defrost
19A044	Radio Speaker Front (LH)	Power Mirrors Radio
19A170	Radio Speaker Jumper	Radio
19B516	Luggage Compartment Lamp	Courtesy Lamps Exterior Lamps Trunk Lid Release
19D887	Air Conditioning Jumper	Air Conditioner/Heater

**SATISFACTION
100%
GUARANTEED**

BUY IT NOW!

Click Here To Order

PayPal American Express Discover MasterCard VISA

LOCATION INDEX 152-4

<u>Component</u>	<u>Base Part No.</u>	<u>Location</u>	<u>Connector</u>	<u>Page Zone</u>	<u>Connector Page</u>
A/C Clutch Diode (2.3L)	14A604	RH side of engine compartment, taped to engine harness		151- 3- C1	
A/C Clutch Diode (5.0L)	14A604	LH side of engine compartment, taped to air conditioner jumper harness		151- 4- F6	
A/C Clutch Field Coil (2.3L)	19703	Lower RH front of engine, part of A/C compressor assembly	C159	151- 3- D1	
A/C Clutch Field Coil (5.0L)	19703	Top LH front of engine, part of A/C compressor assembly	C159	151- 4- F5	
A/C-Heater Control Assembly	19980	Center of I/P	C285	151- 7- F2	
A/C-Heater Control Illumination	18549/19980 ..	Center of I/P, on A/C-heater control assembly	C2017	151- 7- A3	
A4LD Transmission	7005	Under center of car, on transmission	C157	151- 2- A5	
Air Bag Diagnostic Module	14B056	Behind lower center of I/P	C276,C277 ..	151- 8- E1	150- 1
Air Charge Temperature (ACT) Sensor (2.3L)	12A697	RH side of engine compartment, on air cleaner assembly	C160	151- 1- E1	
Air Charge Temperature (ACT) Sensor (5.0L)	12A697	Top LH front of engine, behind coolant temperature sender	C160	151- 4- F8	
Ashtray Illumination	15055	Center console, in ashtray	C319	151-10- A2	
Backup Lamp Switch	15520	LH side of manual transmission	C161	*	
Backup Lamps	13465	Rear of car, on respective sides	C421,C425 ..	151-11- D9	
Backup/Neutral Safety Switch	7A247	LH side of automatic transmission	C162	*	
Barometric Absolute Pressure (BAP) Sensor (2.3L)	12B583	Top center of safety wall	C163	151- 1- A6	
Barometric Absolute Pressure (BAP) Sensor (5.0L)	12B583	Top center of safety wall	C163	151- 4- A5	
Blower Motor	19805	Behind RH side of I/P, in A/C-heater assembly	C286	151- 7- B1	
Blower Motor	19A706	Behind RH side of I/P, in A/C-heater assembly	C287	151- 7- C1	
Blower Motor	19A642	Center of I/P	C2015	151- 7- A4	

100% SATISFACTION GUARANTEED

BUY IT NOW!

Click Here To Order

PayPal American Express Discover MasterCard VISA

152-5 LOCATION INDEX

<u>Component</u>	<u>Base Part No.</u>	<u>Location</u>	<u>Connector</u>	<u>Page Zone</u>	<u>Connector Page</u>
Brake Fluid Level Switch (2.3L)	2L414	LH rear of engine compartment, on brake fluid reservoir	C164	151- 3- B9	
Brake Fluid Level Switch (5.0L)	2L414	LH rear of engine compartment, on brake fluid reservoir	C164	151- 5- A8	
Canister Purge Solenoid (2.3L)	9C915	RH side of engine compartment, forward of shock tower	C1032	151- 1- C1	
Canister Purge Solenoid (5.0L)	9C915	Lower RH front of engine compartment	C165	151- 5- E1	
Cargo Lamp	13776	Center rear of cargo area	C429	151-12- D9	
Center Line Crash Sensor (2.3L)	14B006	Top center of upper radiator support	C166	151- 2- F5	
Center Line Crash Sensor (5.0L)	14B006	Top center of upper radiator support	C166	151- 5- F5	
Cigar Lighter	15052	Center console, in ashtray		151-10- C1	
Clockspring/Slip Ring Assembly	14A664	In top of steering column, below steering wheel	C2010	151- 8- C9	
Clutch Cycling Pressure Switch (2.3L)	19E561	RH rear corner of engine compartment, on A/C accumulator	C167	151- 3- A2	
Clutch Cycling Pressure Switch (5.0L)	19E561	RH rear corner of engine compartment, on A/C accumulator	C167	151- 4- A2	
Clutch Engage Switch (CES)	11A152	Behind LH side of I/P, on clutch pedal support	C288	151- 7- A5	
Clutch Pedal Switch	11A152	Behind LH side of I/P, on clutch pedal support	C290	151- 7- A6	
Clutch Switch	9A837	Behind LH side of I/P, on clutch pedal support	C291	151- 7- F5	
Clutch Switch Jumper	9D821	Behind center of I/P, on I/P support brace	C291	151- 7- F5	
Convertible Top Motor	533A00	Behind top center of rear seat	C409	151-14- F7	
Convertible Top Switch	13A350	Top LH side of I/P, right of instrument cluster	C2023	151- 7- A7	
	10884	LH rear of engine, below oil pressure switch	C168	151- 3- A6	
	10884	Top LH front of engine, LH side of distributor	C168	151- 4- A5	

100% SATISFACTION GUARANTEED

BUY IT NOW!

Click Here To Order

PayPal American Express Discover MasterCard VISA

LOCATION INDEX 152-6

<u>Component</u>	<u>Base Part No.</u>	<u>Location</u>	<u>Connector</u>	<u>Page Zone</u>	<u>Connector Page</u>
Crankshaft Position Sensor	6C315	Center front of engine, near timing chain cover	C111,C112 ...	151- 1- F5	150- 2
DRL Shorting Connector (2.3L)	14A624	In front of LH front fender, below horns	C170	151- 3- E9	
DRL Shorting Connector (5.0L)	14A624	In front of LH front fender, below horns	C170	151- 4- E9	
Daytime Running Lamps (DRL) Module (2.3L)	15A272	In front of LH front fender, below horns	C170	151- 3- E9	150- 2
Daytime Running Lamps (DRL) Module (5.0L)	15A272	In front of LH front fender, below horns	C170	151- 4- E9	150- 2
Distributorless Ignition System (DIS) Module	12A199	Top LH front of engine, forward of intake manifold	C155,C156 ...	151- 2- A2	150- 3
Dome Lamp (With Moonroof)	13776	Center of windshield header	C927	151- 9- A1	
Dome Lamp (Without Moonroof)	13776	Center of roof	C926	151- 9- A5	
Driver's Seat Control Switch		LH side of LH front seat	C302	151-11- F4	
Driver's Seat Motor Assembly		Under LH front seat	C305	151-11- F5	
EEC Power Relay	12A646	Behind RH cowl panel, on bracket, above electronic engine control (EEC) module ..	C293	151- 6- A6	150- 4
EGR Vacuum Regulator Solenoid (2.3L) 9J472		RH rear of engine compartment, on rear of strut tower	C171	151- 1- B1	
EGR Vacuum Regulator Solenoid (5.0L) 9J459		RH rear of engine compartment, on rear of strut tower	C171	151- 5- A2	
EGR Valve Position Sensor (2.3L) 9G428		Top LH rear of engine, on rear of intake manifold	C172	151- 1- A8	
EGR Valve Position Sensor (5.0L) 9G428		Top RH rear of engine, on rear of intake manifold	C172	151- 4- A3	
Electric Cooling Fan	8K621	Center front of engine compartment, behind radiator	C173	151- 3- F4	
Electronic Engine Control (EEC)	12A650	Behind RH cowl panel	C294	151- 6- F7	150- 5
	12A650	Behind RH cowl panel	C294	151- 6- F7	150- 7
	15702	Underside of engine compartment hood	C158	151- 5- A9	

100% SATISFACTION GUARANTEED

BUY IT NOW!

Click Here To Order

PayPal American Express Discover MasterCard VISA

152-7 LOCATION INDEX

<u>Component</u>	<u>Base Part No.</u>	<u>Location</u>	<u>Connector</u>	<u>Page Zone</u>	<u>Connector Page</u>
Engine Coolant Temperature (ECT)					
Sensor (2.3L)	12A648	RH rear of engine, below throttle body	C174	151- 1-	A3
Engine Coolant Temperature (ECT)					
Sensor (5.0L)	12A648	Top RH front of engine, RH side of fuel injector No. 1	C174	151- 4-	A1
Engine Indicator Diode	10C912	Behind LH side of I/P, taped in main harness, near speed control amplifier		151- 8-	F8
Fog Lamp Switch	11654	Top LH side of I/P, left of instrument cluster	C298	151- 7-	B9
Fog Lamps	15200	Lower front of car, on respective sides	C1021,C1025	151-11-	F7
Front Park/Turn Lamps	13200	Front of car, on respective sides	C1024,C1028	151- 3-	F8
Front Side Marker Lamps	15A424	Front of respective front fenders	C1022,C1026	151- 3-	F9
Fuel Gauge Sender	9H307	Below rear of car, top LH side of fuel tank	C410	151-14-	C9
Fuel Injectors (2.3L)	9F593	Top of each cylinder	C178,C179, C180,C181	151- 1-	F4
Fuel Injectors (5.0L)	9F593	Top of each cylinder	C178,C179, C180,C181, C182,C183, C184,C185	151- 4-	B9
Fuel Pump	9350	Below rear of car, top RH side of fuel tank	C411	151-14-	C9
Fuel Pump Relay	14N089	RH side of engine compartment, on lower front of wheelwell	C175	151- 5-	D1 150- 4
Fuse Link A (2.3L)	14526	Front of LH fender apron, at starter relay		151- 3-	D9
Fuse Link A (5.0L)	14526	Front of LH fender apron, at starter relay		151- 4-	D9
Fuse Link B (2.3L)	14526	Front of LH fender apron, at starter relay		151- 3-	D9
Fuse Link B (5.0L)	14526	Front of LH fender apron, at starter relay		151- 4-	D9
Fuse Link C (2.3L)	14526	Front of LH fender apron, at starter relay		151- 3-	D9
Fuse Link C (5.0L)	14526	Front of LH fender apron, at starter relay		151- 4-	D9
Fuse Link D	14526	Front of LH fender apron, at starter relay		151- 4-	D9
	14526	LH side of engine compartment, taped to dash panel to headlamp junction harness, behind battery		151- 3-	F6

100% SATISFACTION GUARANTEED

BUY IT NOW!

Click Here To Order

PayPal American Express Discover MasterCard VISA

LOCATION INDEX 152-8

<u>Component</u>	<u>Base Part No.</u>	<u>Location</u>	<u>Connector</u>	<u>Page Zone</u>	<u>Connector Page</u>
Fuse Link E (5.0L)	14526	LH side of engine compartment, behind battery		151- 4- F9	
Fuse Link F (2.3L)	14526	Front of LH fender apron, at starter relay		151- 3- D9	
Fuse Link F (5.0L)	14526	Front of LH fender apron, at starter relay		151- 4- D9	
Fuse Link G (2.3L)	14526	Front of LH fender apron, at starter relay		151- 3- C9	
Fuse Link G (5.0L)	14526	Front of LH fender apron, at starter relay		151- 4- D9	
Fuse Link H	14526	Front of LH fender apron, at starter relay		151- 3- C9	
Fuse Link J	14526	Front of LH fender apron, at starter relay		151- 3- C9	
Fuse Link K (2.3L)	14526	RH rear corner of engine compartment, taped to engine harness		151- 2- B1	
Fuse Link K (5.0L)	14526	RH rear corner of engine compartment, taped to engine harness		151- 4- A1	
Fuse Link N (2.3L)	14526	LH rear corner of engine compartment, taped to main harness		151- 2- A9	
Fuse Link N (5.0L)	14526	LH rear corner of engine compartment, taped in main harness		151- 4- B9	
Fuse Panel	14A067	Behind LH side of I/P, left of steering column	C206	151- 7- E9	
Glove Box Lamp	14413	RH side of I/P, in glove box	C2016	151- 8- B1	
Graphic Equalizer	18T803	Center of I/P, below radio	C2030	151- 8- F7	150- 4
Hatchback Release Solenoid	14030	Center rear of hatchback, near latch assembly	C412	151-12- C9	
Hazard Flasher	13350	Behind LH side of I/P, on fuse panel		151- 7- F8	
Hazard Warning Switch	13A350	Top LH side of I/P, RH side of instrument cluster	C299	151- 7- A6	150- 9
Headlamps	13005	Front of car, on respective sides	C1023,C1027	151- 3- F9	
Heated Exhaust Gas Oxygen (HEGO)					
HEGO	9F472	Lower RH rear of engine, in exhaust manifold	C186	151- 1- C1	
HEGO	18549	Center of I/P	C285	151- 7- F1	
HEGO	13A613	Center of rear package tray	C321	151-10- E9	
HEGO	13A613	In center of rear spoiler	C430	151-13- C9	

100% SATISFACTION GUARANTEED

BUY IT NOW!

Click Here To Order

152-9 LOCATION INDEX

<u>Component</u>	<u>Base Part No.</u>	<u>Location</u>	<u>Connector</u>	<u>Page Zone</u>	<u>Connector Page</u>
Hi Mount Stop Lamp (Convertible)	13A613	Center rear of trunk lid	C431	151-15- A9	
Horn Relay	13853	Behind RH center of I/P, above warning chime module	C187	151- 7- A3	150- 9
Horns (2.3L)	13A803	In front of LH fender, near windshield washer fluid reservoir	C188,C189	151- 2- E9	
Horns (5.0L)	13A803	In front of LH fender, near windshield washer fluid reservoir	C188,C189	151- 5-E10	
Idle Air Bypass Valve (2.3L)	9F715	Top rear of engine, above valve cover	C190	151- 1- A5	
Idle Air Bypass Valve (5.0L)	9F715	Top RH side of engine, forward of throttle body	C190	151- 4- C1	
Ignition Coil	12029	LH side of engine compartment, on front of strut tower	C191	151- 5-C10	
Ignition Key Warning Switch	11A127	Top RH side of steering column, part of ignition lock cylinder	C2026	151- 7- A9	
Ignition Suppression Resistor	14A601	LH rear corner of engine compartment, taped to engine harness		151- 4- A8	
Ignition Switch	11572	Top RH side of steering column	C2001	151- 7- A8	150- 9
In-line Circuit Breaker (2.3L)	14A065	Front of LH fender apron, on starter relay		151- 3- B9	
In-line Circuit Breaker (5.0L)	14A065	Front of LH fender apron, on starter relay		151- 4- C9	
Inertia Switch	9341	Lower LH center rear of trunk	C413	151- 9- E9	
Instrument Cluster	10849	Top LH side of I/P	C250,C251	151- 8- A6	150-10
Instrument Panel Dimming Rheostat	11691	LH side of I/P, left of steering column	C2022	151- 8- C9	
Integral Alternator Regulator (IAR) (2.3L)	10300/10346	Top LH front of engine	C153,C154	151- 3- F5	150-12
Integral Alternator Regulator (IAR) (5.0L)	10300/10346	RH front of engine	C153,C154	151- 4- F3	150-12
Integrated Relay Control Module	12B581	Mounted on side of RH front strut tower	C192	151- 3- A1	150-11
Governor	6C625	Behind LH side of I/P, LH side of steering column brace	C2002	151- 8- E9	150-12
	13A025	Behind RH center of I/P, near horn relay	C2004	151- 7- A2	150-13
	18808	Behind top LH corner of I/P	C2025	151- 8- B9	
	218A42	In rear of LH front door	C503	151-11- E1	

100% SATISFACTION GUARANTEED

BUY IT NOW!

Click Here To Order

PayPal American Express Discover MasterCard VISA

LOCATION INDEX 152-10

<u>Component</u>	<u>Base Part No.</u>	<u>Location</u>	<u>Connector</u>	<u>Page Zone</u>	<u>Connector Page</u>
Left Door Lock Switch	14A509	Center of LH front door, on armrest	C507	151-11- D1	150- 2
Left Door Speaker	18808	In lower front of LH front door	C508	151-10- D1	
Left Forward Crash Sensor (2.3L)	14B005	LH side of upper radiator support, behind headlamp	C177	151- 2- F8	
Left Forward Crash Sensor (5.0L)	14B005	LH side of upper radiator support, behind headlamp	C177	151- 5- F8	
Left Front Courtesy Lamp Switch	13713	In front of LH front door jamb	C297	151- 6- F5	
Left Front Window Motor	23394	In lower front of LH front door	C504	151-11- F3	
Left Heated Exhaust Gas Oxygen (HEGO) Sensor	9F472	Lower LH rear of engine, in exhaust manifold	C193	151- 5- A6	
Left Power Lumbar Compressor Motor	65530	Under RH side of LH front seat	C307	151-10- F4	
Left Power Lumbar Seat Switch	14C715	On LH side of LH front seat	C323	151-10- F2	
Left Power Mirror	17682	Top front of LH front door	C509	151-11- C1	
Left Rear Speaker (2 Door)	18971	LH side of rear package tray	C325	151-10- F8	
Left Rear Speaker (3 Door)	18932	LH front of cargo area	C325	151-12- F6	
Left Rear Speaker (Convertible)	18971	Front of LH rear quarter panel, in trim panel	C325	151-14- F5	
Left Rear Window Motor	23394	In front of LH rear quarter panel	C311	151-14- F4	
Left Vanity Mirror Lamp	17A679	At LH vanity mirror	C917	151- 9- C1	
License Lamps (2 Door And Convertible)	13550	Center rear of trunk lid	C426,C427	151-11- E9	
License Lamps (3 Door)	13550	Center rear of hatchback	C427,C426	151-13- E9	
Low Coolant Switch	10D968	LH front of engine compartment, in coolant reservoir	C194	151- 4- F9	
Low Oil Level Sensor	6C624	Lower LH rear of engine, on side of oil pan	C195	151- 5- A6	
Low Oil Warning Relay	6C625	Behind LH side of I/P, LH side of steering column brace	C196	151- 8- D9	150-13
Low Oil Warning Relay	9345	Behind top center of rear seat, LH side of convertible top motor	C414	151-14- F6	150-13
Low Oil Warning Relay	19B516	Center rear of trunk lid	C428	151- 9- D9	
Low Oil Warning Relay	19B516	LH rear of trunk lid	C428	151-14- F8	

100% SATISFACTION GUARANTEED

BUY IT NOW!

Click Here To Order

PayPal American Express Discover MasterCard VISA

152-11 LOCATION INDEX

<u>Component</u>	<u>Base Part No.</u>	<u>Location</u>	<u>Connector</u>	<u>Page Zone</u>	<u>Connector Page</u>
Main Light Switch	11654	Top LH side of I/P, LH side of instrument cluster	C2005	151- 7- B9	150-13
Map Lamp (2 And 3 Door)	13776	Center of roof	C918	151- 9- A7	
Map Lamp (Convertible)	13776	Center of windshield header	C900	151-15- A4	
Mass Air Flow (MAF) Sensor (2.3L) ..	12B579	RH side of engine compartment, on rear of air cleaner assembly	C197	151- 1- D1	
Mass Air Flow (MAF) Sensor (5.0L) ..	12B579	RH side of engine compartment, on air intake assembly	C197	151- 4- D1	
Master Window/Door Lock Control Switch (2 And 3 Door)	14A509	Center of LH front door, on armrest	C502	151-11- D1	150-24
Master Window/Door Lock Control Switch (Convertible)	14A509	Center of front LH door, on armrest	C505	151-15- C1	150-24
Multi-function Switch	13K359	Inside top of steering column	C268,C269, C270	151- 8- A8	150-14
Neutral Gear Switch (NGS)	7A247	Top front of manual transmission	C117	151-11- B1	
Octane Adjust Shorting Bar	14A464	RH rear of engine compartment	C1000	151- 2- A4	
Oil Pressure Sender	9D290	Lower LH front of engine, above oil filter ..	C1001	151- 5- F6	
Oil Pressure Switch	9278	LH rear of engine, below valve cover	C1002	151- 3- A5	
PRNDL Illumination	15A808	Center console, near gearshift lever	C320	151-10- E1	
Park Brake Switch	15852	Below rear of center console, on RH rear of park brake lever assembly	C2006	151-10- F6	
Power Mirror Switch	17B676	On center console	C350	151- 9- D1	150-15
Power Steering Pressure Switch	3N824	Lower LH side of engine, near power steering pump	C1003	151- 1- F7	
Premium Sound Amplifier	18B849	Below front of center console	C282,C283 ..	151- 8- C1	150-15
Primary Coil (RH)	12029	Top RH side of engine, right of valve cover .	C1004	151- 2- C1	
Radio (With Premium Sound)	18806	Center of I/P	C280,C281 ..	151- 8- F3	150-18
Radio (Without Premium Sound)	18806	Center of I/P	C257,C258 ..	151- 8- F3	150-17
Secondary Coil (RH)	18801	Top RH front of engine, near secondary coil (LH)	C1006	151- 2- F4	
Convertible Top Motor	9345	Behind top center of rear seat, LH side of convertible top motor	C415	151-14- F6	150-20

100% SATISFACTION GUARANTEED

BUY IT NOW!

Click Here To Order

PayPal American Express Discover MasterCard VISA

LOCATION INDEX 152-12

<u>Component</u>	<u>Base Part No.</u>	<u>Location</u>	<u>Connector</u>	<u>Page Zone</u>	<u>Connector Page</u>
Rear Courtesy Lamp Switch	13713	Center rear of hatchback	C416	151-12- D9	
Rear Crash Sensor	14B007	In lower front of LH rear quarter panel	C309	151- 9- F3	150-20
Rear Park/Stop Lamps	13465	Rear of car, on respective sides	C419,C424	151-11- C9	
Rear Side Marker Lamps	13465	Rear of car, on respective sides	C420,C423	151-11- C9	
Rear Turn Lamps	13465	Rear of car, on respective sides	C418,C422	151-11- C9	
Rear Window Defrost Control Relay	18C641	Behind LH side of I/P, on RH side of fuse panel	C2007	151- 7- E9	150-20
Rear Window Defrost Grid	42006	Inside rear window		151- 9- A8	
Rear Window Defrost Switch	13A350	Top LH side of I/P, right of instrument cluster	C2020	151- 7- A7	
Right Dash Speaker	18808	Behind top RH corner of I/P	C2024	151- 8- A2	
Right Door Lock Motor	218A42	Rear of RH front door	C603	151-11- B9	
Right Door Lock Switch	14A265	Center of RH front door, on armrest	C606	151-11- A8	150- 2
Right Door Speaker	18808	Lower front of RH front door	C607	151-10- A5	
Right Forward Crash Sensor (2.3L)	14B004	RH side of upper radiator support, behind headlamp	C176	151- 2- F3	
Right Forward Crash Sensor (5.0L)	14B004	RH side of upper radiator support, behind headlamp	C176	151- 5- F2	
Right Front Courtesy Lamp Switch	13713	In front of RH front door jamb	C296	151- 6-C10	
Right Front Window Motor	23394	In lower front of RH front door	C604	151-11- B9	
Right Heated Exhaust Gas Oxygen (HEGO) Sensor	9F472	Lower RH rear of engine, in exhaust manifold	C1005	151- 5- A4	
Right Power Lumbar Compressor Motor	65530	Under LH side of RH front seat	C308	151-10- B9	
Right Power Lumbar Seat Switch	14C715	On RH side of RH front seat	C322	151-10- B9	
Right Power Mirror	17682	Top front of RH front door	C608	151-11- A5	
Right Rear Speaker (2 Door)	18971	RH side of rear package tray	C324	151-10- D9	
Right Rear Speaker (3 Door)	18932	RH front of cargo area	C324	151-12- A8	
	18971	Front of RH rear quarter panel, in trim panel	C324	151-14- B9	
	23394	In front of RH rear quarter panel	C312	151-14- A9	
	17A679	At RH vanity mirror	C916	151- 9- A2	
	14A265	Center of RH front door, on armrest	C602	151-11- A6	150-25

100% SATISFACTION GUARANTEED

BUY IT NOW!

Click Here To Order

PayPal American Express Discover MasterCard VISA

152-13 LOCATION INDEX

<u>Component</u>	<u>Base Part No.</u>	<u>Location</u>	<u>Connector</u>	<u>Page Zone</u>	<u>Connector Page</u>
SPOUT Check Connector C1009 (2.3L)	14A464	Top LH front of engine, near distributorless ignition system (DIS) module	C1009	151- 2-	A6
SPOUT Check Connector C1009 (5.0L)	14A464	LH front of engine, taped to engine harness, near distributor	C1009	151- 4-	F5
Seat Belt Switch	10B924	Inside LH front seat belt buckle assembly	C315	151-15-	F5
Secondary Coil (LH)	12029	Top RH front of engine, right of valve cover	C1007	151- 2-	E1
Shift Lock Actuator	3F719	Top RH side of steering column, near ignition switch	C2008	151- 8-	A7
Speed Control Amplifier	9D843	Behind LH side of I/P, near top of cowl panel	C214,C215	151- 7-	F7 150-21
Speed Control Servo (2.3L)	9C735	In rear of LH front fender	C1008	151- 3-	A9 150-22
Speed Control Servo (5.0L)	9C735	In rear of LH front fender	C1008	151- 4-	A9 150-22
Starter Motor/Solenoid (2.3L)	11001	Lower RH rear of engine		151- 3-	A4
Starter Motor/Solenoid (5.0L)	11001	Lower RH rear of engine		151- 4-	C1
Starter Relay (2.3L)	11450	Front of LH fender apron		151- 3-	C9
Starter Relay (5.0L)	11450	Front of LH fender apron		151- 4-	C9
Steering Column Air Bag	043B13	In center of steering wheel	C2009	151- 6-	F6
Steering Wheel Control Switch	9C888	Center of steering wheel	C2018	151- 6-	A5
Stop Lamp Switch	13480	Behind LH side of I/P, on brake pedal support	C2011	151- 7-	F4
TFI Ignition Module	12A297	Center front of engine, on LH side of distributor	C1012	151- 4-	F4 150-22
Tach Service Connector	14A624	LH front of engine, near distributorless ignition system (DIS) module	C1011	151- 2-	A6
Thermactor Air Bypass (TAB) Solenoid	95448	RH rear of engine compartment, on rear of strut tower	C1013	151- 5-	B1
Thermactor Air Diverter (TAD) Solenoid	95448	RH rear of engine compartment, on rear of strut tower	C1014	151- 5-	A1
	9B989	Top rear of engine, on throttle body	C1031	151- 1-	A5
	9B989	Top RH side of engine, on rear of throttle body	C1015	151- 5-	A3

100% SATISFACTION GUARANTEED

BUY IT NOW!

Click Here To Order

PayPal American Express Discover MasterCard VISA

LOCATION INDEX 152-14

<u>Component</u>	<u>Base Part No.</u>	<u>Location</u>	<u>Connector</u>	<u>Page Zone</u>	<u>Connector Page</u>
Trunk Lid Release Solenoid (2 Door)	14030	Center rear of trunk lid, near latch assembly	C417	151- 9-	C9
Trunk Lid Release Solenoid (Convertible)	14030	Center rear of trunk lid, near latch assembly	C417	151-14-	D9
Trunk Lid/Hatchback Release Switch	19B514	RH side of I/P, in glove box	C2019	151- 7-	A1
Turn Signal Flasher	13350	Behind RH center of I/P	C2012	151- 7-	F3
VIP Test Connector C198 (2.3L)	14489	LH rear of engine compartment, mounted on rear of strut tower	C198	151- 2-	A9 150-22
VIP Test Connector C198 (5.0L)	14489	LH rear of engine compartment, mounted on rear of strut tower	C198	151- 5-	B9 150-22
VIP Test Connector C199 (2.3L)	14489	LH rear of engine compartment, mounted on rear of strut tower	C199	151- 2-	A9 150-22
VIP Test Connector C199 (5.0L)	14489	LH rear of engine compartment, mounted on rear of strut tower	C199	151- 5-	B9 150-22
Vehicle Speed Sensor (VSS)	9E731	LH rear of transmission	C1016	151-11-	B1
WOT Cutout Relay	14N089	RH side of engine compartment, on lower front of wheel well	C1020	151- 5-	D1 150-26
Warning Chime Module	10D840	Behind center of I/P, RH side of radio	C2013	151- 7-	D1 150-23
Window Safety Relay	9345	Behind top of LH cowl panel	C2014	151- 6-	B1 150-23
Windshield Washer Pump Motor (2.3L)	17B613	In front of LH fender, in windshield washer fluid reservoir	C1018	151- 2-	D10
Windshield Washer Pump Motor (5.0L)	17B613	In front of LH fender, in windshield washer fluid reservoir	C1018	151- 5-	D10
Windshield Washer Pump Test Connector C1019 (2.3L)	14489	Lower LH side of engine compartment, taped to main harness	C1019	151- 2-	C10
Windshield Washer Pump Test Connector C1019 (5.0L)	14489	Lower LH side of engine compartment, taped to main harness	C1019	151- 5-	C10
	17504	Top LH side of safety wall, RH side of hood hinge	C151,C152	151- 2-	A7 150-26
	17504	Top LH side of safety wall, RH side of hood hinge	C151,C152	151- 4-	A7 150-26

100% SATISFACTION GUARANTEED

BUY IT NOW!

Click Here To Order

PayPal American Express Discover MasterCard VISA

152-15 LOCATION INDEX

<u>Connector</u>	<u>Location</u>	<u>Page Zone</u>	<u>Connector Page</u>	<u>Color</u>	<u>Terminal</u>
C100	Lower LH front of engine compartment	151- 4- F9		BK	2
C101 (2.3L)	LH rear side of engine, rear of intake manifold	151- 1- C9		BK	8
C101 (5.0L)	RH side of engine compartment, lower front of wheel well	151- 1- C9		BK	8
C102	LH rear corner of engine compartment	151- 3- A9		GY	2
C104	LH rear of engine, rear of intake manifold	151- 1- B9		BK	8
C105	LH rear of engine, rear of intake manifold	151- 1- D9		N	8
C106 (Automatic)	LH rear of transmission	151- 11- B1		GY	4
C106 (Manual)	LH side of transmission	151- 11- B1		GY	4
C107 (2.3L)	LH side of engine compartment, on lower front of wheel well	151- 1- F8		BL	2
C107 (5.0L)	LH side of engine compartment, on lower front of wheel well	151- 4- C9		BL	2
C108 (2.3L)	LH side of engine compartment, on lower front of wheel well	151- 1- F8		BK	8
C108 (5.0L)	LH side of engine compartment, on lower front of wheel well	151- 4- D9		BK	8
C110 (2.3L)	LH rear of engine compartment, left of brake fluid reservoir	151- 2- A8		BR	8
C110 (5.0L)	LH rear of engine compartment, left of brake fluid reservoir	151- 5-B10		BR	8
C111	LH side of engine, near bottom of intake manifold, to crankshaft position sensor	151- 1- F6	150- 2	GY	1
C112	LH side of engine, near bottom of intake manifold, to crankshaft position sensor	151- 1- F6	150- 2	GY	4
C113 (2.3L)	LH front of engine compartment, behind battery	151- 2- D9		BK	1
C113 (5.0L)	LH front of engine compartment, behind battery	151- 5-D10		BK	1
C117	LH front of manual transmission, on neutral gear switch (NGS)	151- 11- B1		BK	2
C118	Top RH rear of engine, on rear of intake manifold	151- 4- A4		BK	10
C119	Top RH rear side of engine, on rear of intake manifold	151- 4- A4		GY	10
C151 (2.3L)	Top LH side of safety wall, on windshield wiper motor	151- 2- A7	150-26	GY	3
C151 (5.0L)	Top LH side of safety wall, on windshield wiper motor	151- 4- A7	150-26	GY	3
C152 (2.3L)	Top LH side of safety wall, on windshield wiper motor	151- 2- A7	150-26	BK	3
C152 (5.0L)	Top LH side of safety wall, on windshield wiper motor	151- 4- A7	150-26	BK	3
C152 (2.3L)	Top LH front of engine, on integral alternator regulator (IAR)	151- 3- F5	150-12	BK	3
	... RH front of engine, on integral alternator regulator (IAR)	151- 4- F3	150-12	BK	3
	... Top LH front of engine, on integral alternator regulator (IAR)	151- 3- F5	150-12	BK	3
	... RH front of engine, on integral alternator regulator (IAR)	151- 4- F3	150-12	BK	3
	(DIS) module	151- 2- A2	150- 3	GY	6

100% SATISFACTION GUARANTEED

BUY IT NOW!

Click Here To Order

PayPal American Express Discover MasterCard VISA

LOCATION INDEX 152-16

<u>Connector</u>	<u>Location</u>	<u>Page Zone</u>	<u>Connector Page</u>	<u>Color</u>	<u>Terminal</u>
C155	Top LH front of engine, on distributorless ignition system (DIS) module	151- 2- A2	.. 150- 3	GY	6
C156	LH front of engine, on distributorless ignition system (DIS) module	151- 2- A2	.. 150- 3	GY	6
C157	Under center of car, on A4LD transmission	151- 2- A5		BK	3
C158	Underside of engine compartment hood, on engine compartment lamp	151- 5- A9		GY	2
C159 (2.3L)	Lower RH front of engine, on A/C clutch field coil	151- 3- D1		BK	2
C159 (5.0L)	Top LH front of engine, on A/C clutch field coil	151- 4- F5		BK	2
C160 (2.3L)	RH side of engine compartment, on air charge temperature (ACT) sensor	151- 1- E1		BK	2
C160 (5.0L)	Top LH front of engine, on air charge temperature (ACT) sensor	151- 4- F8		BK	2
C161	LH side of manual transmission, on backup lamp switch	*		BK	2
C162	LH side of automatic transmission, on backup/neutral safety switch	*		BK	4
C163 (2.3L)	Top center of safety wall, on barometric absolute pressure (BAP) sensor	151- 1- A6		BK	3
C163 (5.0L)	Top center of safety wall, on barometric absolute pressure (BAP) sensor	151- 4- A5		BK	3
C164 (2.3L)	LH rear of engine compartment, on brake fluid level switch	151- 3- B9		GY	3
C164 (5.0L)	LH rear of engine compartment, on brake fluid level switch	151- 5- A8		GY	3
C165	Lower RH front of engine, to canister purge solenoid	151- 5- F5		BK	2
C166 (2.3L)	RH side of engine compartment, to center line crash sensor	151- 2- D1			2
C166 (5.0L)	RH side of engine compartment, to center line crash sensor	151- 5- A1			2
C167 (2.3L)	RH rear corner of engine compartment, on clutch cycling pressure switch	151- 3- A2		GY	3
C167 (5.0L)	RH rear corner of engine compartment, on clutch cycling pressure switch	151- 4- A2		GY	3
C167 (2.3L)	LH rear of engine, on coolant temperature sender	151- 3- A6		BK	1
C167 (5.0L)	Top LH front of engine, on coolant temperature sender	151- 4- A5		BK	1
C167 (5.0L)	In front of LH front fender, on daytime running lamps (DRL) module or DRL shorting connector	151- 3- E9	.. 150- 2	BK	8

100% SATISFACTION GUARANTEED

BUY IT NOW!

Click Here To Order

PayPal American Express Discover MasterCard VISA

152-17 LOCATION INDEX

<u>Connector</u>	<u>Location</u>	<u>Page</u> <u>Zone</u>	<u>Connector</u> <u>Page</u>	<u>Color</u>	<u>Terminal</u>
C170 (5.0L)	In front of LH front fender, on daytime running lamps (DRL) module or DRL shorting connector	151- 4- E9	150- 2	BK	8
C171 (2.3L)	RH rear of engine compartment, on EGR vacuum regulator solenoid	151- 1- B1		BK	2
C171 (5.0L)	RH rear of engine compartment, on EGR vacuum regulator solenoid	151- 5- A2		BK	2
C172 (2.3L)	Top LH rear of engine, on EGR valve position sensor	151- 1- A8		BK	4
C172 (5.0L)	Top RH rear of engine, on EGR valve position sensor	151- 4- A3		BK	4
C173	Center front of engine compartment, on electric cooling fan	151- 3- F4		BK	2
C174 (2.3L)	RH rear of engine, on engine coolant temperature (ECT) sensor	151- 1- A3		BR	2
C174 (5.0L)	Top RH front of engine, on engine coolant temperature (ECT) sensor	151- 4- E1		BR	2
C176 (2.3L)	RH side of engine compartment, to right forward crash sensor	151- 2- D1		N	2
C176 (5.0L)	RH side of engine compartment, to right forward crash sensor	151- 5- C1		N	2
C177 (2.3L)	LH side of engine compartment, to left forward crash sensor	151- 2- A9		N	2
C177 (5.0L)	LH side of engine compartment, to left forward crash sensor	151- 5-C10		N	2
C178 (2.3L)	Top of engine, on fuel injector No. 1	151- 1- F4		BK	2
C178 (5.0L)	Top of engine, on fuel injector No. 1	151- 4- B9		BK	2
C179 (2.3L)	Top of engine, on fuel injector No. 2	151- 1- F4		BK	2
C179 (5.0L)	Top of engine, on fuel injector No. 2	151- 4- B9		BK	2
C180 (2.3L)	Top of engine, on fuel injector No. 3	151- 1- F4		BK	2
C180 (5.0L)	Top of engine, on fuel injector No. 3	151- 4- B9		BK	2
C181 (2.3L)	Top of engine, on fuel injector No. 4	151- 1- F4		BK	2
C181 (5.0L)	Top of engine, on fuel injector No. 4	151- 4- B9		BK	2
C182	Top of engine, on fuel injector No. 5	151- 4- B9		BK	2
C183	Top of engine, on fuel injector No. 6	151- 4- B9		BK	2
C184	Top of engine, on fuel injector No. 7	151- 4- B9		BK	2
C185	Top of engine, on fuel injector No. 8	151- 4- B9		BK	2
	Lower RH rear of engine, near heated exhaust gas oxygen (HEGO) sensor	151- 1- A3		N	4
	Behind RH center of I/P, on horn relay	151- 7- A3	150- 9	BR	5
	In front of LH fender, on high pitch horn	151- 2- E9		BK	1
	In front of LH fender, on high pitch horn	151- 5-E10		BK	1
	In front of LH fender, on low pitch horn	151- 2- E9		BK	1

100% SATISFACTION GUARANTEED

BUY IT NOW!

Click Here To Order

PayPal American Express Discover MasterCard VISA

LOCATION INDEX 152-18

<u>Connector</u>	<u>Location</u>	<u>Page Zone</u>	<u>Connector Page</u>	<u>Color</u>	<u>Terminal</u>
C189 (5.0L)	In front of LH fender, on low pitch horn	151- 5-D10		BK	1
C190 (2.3L)	Top rear of engine, on idle air bypass valve	151- 1- A5		BK	2
C190 (5.0L)	Top RH side of engine, on idle air bypass valve	151- 4- C1		BK	2
C191	LH side of engine compartment, on ignition coil	151- 5-B10		GY	3
C192	Mounted on side of RH front strut tower, on integrated relay control module	151- 3- A1	.. 150-11		24
C193	Lower LH rear of engine, near left heated exhaust gas oxygen (HEGO) sensor	151- 5- A7		BK	4
C194	LH front of engine compartment, on low coolant switch	151- 4- F9		BK	3
C195	Lower LH rear of engine, on low oil level sensor	151- 5- A6		N	1
C196	Behind LH side of I/P, on low oil warning relay	151- 8- D9	.. 150-13	GY	5
C197 (2.3L)	RH side of engine compartment, on mass air flow (MAF) sensor	151- 1- D1		BK	4
C197 (5.0L)	RH side of engine compartment, on mass air flow (MAF) sensor	151- 4- D1		BK	4
C198 VIP Test Connector (2.3L)	LH rear of engine compartment, mounted on rear of strut tower	151- 2- A9	.. 150-22	GY	6
C198 VIP Test Connector (5.0L)	LH rear of engine compartment, mounted on rear of strut tower	151- 5-B10	.. 150-22	GY	6
C199 VIP Test Connector (2.3L)	LH rear of engine compartment, mounted on rear of strut tower	151- 2- A9	.. 150-22	GY	1
C199 VIP Test Connector (5.0L)	LH rear of engine compartment, mounted on rear of strut tower	151- 5-B10	.. 150-22	GY	1
C203	Behind LH cowl panel	151- 6- E1		BK	12
C204	Behind LH cowl panel, taped to main harness	151- 6- C1		GY	2
C205	Behind RH cowl panel, near electronic engine control (EEC) module	151- 6-B10		GY	2
C206	Behind LH side of I/P, on rear of fuse panel	151- 7- F8		W	1
C207	Behind LH cowl panel	151- 6- D1		GY	12
C212	Behind LH cowl panel	151- 6- D1		BK	8
C213	Behind RH cowl panel, below electronic engine control (EEC) module	151- 6-C10		GR	8
C214	Behind LH side of I/P, on speed control amplifier	151- 7- F7	.. 150-21		6
C215	Behind LH side of I/P, on speed control amplifier	151- 7- F7	.. 150-21	GY	6
C216	Behind RH cowl panel, below electronic engine control (EEC) module	151- 6-C10		GY	8
C217	Behind LH cowl panel	151- 6- F2		GY	8
C218	Behind LH cowl panel	151- 6- F3		GY	8
C219	Behind RH cowl panel, above grommet	151- 6- A7		GY	8
C220	Behind LH cowl panel	151- 6- F4		BL	6

100% SATISFACTION GUARANTEED

BUY IT NOW!

Click Here To Order

PayPal American Express Discover MasterCard VISA

152-19 LOCATION INDEX

<u>Connector</u>	<u>Location</u>	<u>Page Zone</u>	<u>Connector Page</u>	<u>Color</u>	<u>Terminal</u>
C225	Behind LH cowl panel	151- 6- F3		BK	4
C227	Behind LH cowl panel	151- 6- A2		GY	2
C228	Behind RH cowl panel, below grommet	151- 6-B10		GY	2
C229	Behind LH cowl panel	151- 6- A4		GY	8
C230	Behind LH cowl panel	151- 6- A4		BK	4
C231	Behind RH cowl panel	151- 6-B10		BK	4
C250	Behind top LH side of I/P, on instrument cluster	151- 8- A9	150-10	GY	14
C251	Behind top LH side of I/P, on instrument cluster	151- 8- A6	150-10	BR	14
C257 (With Premium Sound)	Behind center of I/P, near RH side of radio	151- 8- A3		BK	8
C257 (Without Premium Sound)	Behind center of I/P, on rear of radio	151- 8- F3	150-17	BK	8
C258 (With Premium Sound)	Behind center of I/P, near RH side of radio	151- 8- A5		BK	8
C258 (Without Premium Sound)	Behind center of I/P, on rear of radio	151- 8- F5	150-17	BK	8
C268	Inside top of steering column, on multi-function switch	151- 8- A8	150-14	GY	4
C269	Inside top of steering column, on multi-function switch	151- 8- A8	150-14	GY	10
C270	Inside top of steering column, on multi-function switch	151- 8- A8	150-14	GY	9
C276	Behind lower center of I/P, on air bag diagnostic module	151- 8- E1	150- 1		12
C277	Behind lower center of I/P, on air bag diagnostic module	151- 8- D1	150- 1		12
C280	Behind center of I/P, on rear of radio	151- 8- F3	150-18	BK	8
C281	Behind center of I/P, on rear of radio	151- 8- F5	150-18	BK	8
C282	Below front of center console, on premium sound amplifier	151- 8- C1	150-15	GR	8
C283	Below front of center console, on premium sound amplifier	151- 8- C1	150-16	GY	8
C285 (With A/C)	Behind center of I/P, on A/C-heater control assembly	151- 7- F2		W	4
C285 (Without A/C)	Behind center of I/P, on heater control assembly	151- 7- F2		W	4
C286	Behind RH side of I/P, near blower motor	151- 7- B1		BK	2
C287	Behind RH side of I/P, on blower motor resistor assembly	151- 7- C1		W	4
C288	Behind LH side of I/P, on clutch interrupt switch	151- 7- A5		BK	2
C290	Behind LH side of I/P, on clutch engage switch (CES)	151- 7- A6		N	2
	Behind LH side of I/P, on clutch switch or clutch switch jumper	151- 7- F4		GY	2
	Behind RH cowl panel, on EEC power relay	151- 6- A6	150- 4	BR	5
	Behind RH cowl panel, on electronic engine control (EEC) module	151- 6- F7	150- 5	GY	60

100% SATISFACTION GUARANTEED

BUY IT NOW!

Click Here To Order

LOCATION INDEX 152-20

<u>Connector</u>	<u>Location</u>	<u>Page Zone</u>	<u>Connector Page</u>	<u>Color</u>	<u>Terminal</u>
C294 (5.0L)	Behind RH cowl panel, on electronic engine control (EEC) module	151- 6- F7	.. 150- 7	GY	60
C296	In front of RH front door jamb, on right front courtesy lamp switch	151- 6-C10		BK	3
C297	In front of LH front door jamb, on left front courtesy lamp switch	151- 6- F5		BK	3
C298	Behind top LH side of I/P, on fog lamp switch	151- 7- B9		N	2
C299	Behind top LH side of I/P, on hazard warning switch	151- 7- A6	.. 150- 9	GY	8
C300	Below LH front seat	151- 10- F5		GY	2
C301	Below RH front seat	151- 12- A5		GY	2
C302	Under LH side of LH front seat, on driver's seat control switch	151- 11- F4			6
C303	Below center console	151- 10- A4		GY	3
C304	Below LH front seat	151- 11- A4			2
C305	Under LH front seat, on driver's seat motor assembly	151- 11- F6			4
C307	Under RH side of LH front seat, on left power lumbar compressor motor	151- 10- F4		BK	2
C308	Under LH side of RH front seat, on right power lumbar compressor motor	151- 12- A7		BK	2
C309	In lower front of LH rear quarter panel, near rear crash sensor	151- 12- F5	.. 150-20	N	8
C311	In front of LH rear quarter panel, near left rear window motor	151- 14- F4		GY	2
C312	In front of RH rear quarter panel, near right rear window motor	151- 14- A9		GY	2
C315	Below RH side of LH front seat, near seat belt switch	151- 10- A4		GY	2
C319	Below center console, on ashtray illumination	151- 10- A2		BK	2
C320	Below center console, on PRNDL illumination	151- 10- E1		GY	2
C321 (2 Door)	LH side of trunk, above rear of wheel well, to hi mount stop lamp	151- 10- F7		GY	2
C321 (3 Door)	LH side of cargo area	151- 13- F5		GY	2
	On RH side of RH front seat, on right power lumbar seat switch	151- 10- B9		GY	2
	On LH side of LH front seat, on left power lumbar seat switch	151- 10- F2		GY	2
	RH side of rear package tray, on right rear speaker	151- 10- D9		GY	2
	RH front of cargo area, on right rear speaker	151- 12- A8		GY	2
	In front of RH rear quarter panel, on right rear speaker	151- 14- B9		GY	2

100% SATISFACTION GUARANTEED

BUY IT NOW!

Click Here To Order

PayPal American Express Discover MasterCard VISA

152-21 LOCATION INDEX

<u>Connector</u>	<u>Location</u>	<u>Page Zone</u>	<u>Connector Page</u>	<u>Color</u>	<u>Terminal</u>
C325 (2 Door)	LH side of rear package tray, on left rear speaker	151- 10- F8		GY	2
C325 (3 Door)	LH front of cargo area, on left rear speaker	151- 12- F6		GY	2
C325 (Convertible)	In front of LH rear quarter panel, on left rear speaker	151- 14- F5		GY	2
C350	Below center console, on power mirror switch	151- 9- D1	... 150-15	GY	8
C400	Below rear of car, above fuel tank	151- 9- B9		BR	4
C401	LH rear corner of hatchback	151- 12- F7		GY	3
C403 (2 Door)	LH side of trunk, above rear of wheel well	151- 9- F9		GY	3
C403 (3 Door)	LH side of cargo area, above rear of wheel well	151- 13- F6		GY	3
C403 (Convertible)	LH front of trunk, above wheel well	151- 15- F7		GY	3
C405 (2 Door)	LH side of trunk, above rear of wheel well	151- 9- F8			3
C405 (3 Door)	LH side of cargo area, above rear of wheel well	151- 13- F6			3
C405 (Convertible)	LH front of trunk, above wheel well	151- 15- F6		GY	1
C406 (2 Door)	LH side of trunk, above rear of wheel well	151- 9- F6		BR	1
C406 (3 Door)	LH side of cargo area, above rear of wheel well	151- 12- F9		BR	1
C407	LH rear corner of hatchback	151- 12- F7		BR	1
C408	LH rear corner of hatchback	151- 12- F7			3
C409	Behind top center of rear seat, near convertible top motor	151- 14- F7		BK	2
C410	Below rear of car, on fuel gauge sender	151- 14- C9		GY	2
C411	Below rear of car, on fuel pump	151- 12- E9		R	2
C412	Center rear of hatchback, on hatchback release solenoid	151- 12- C9		N	2
C413	Lower LH center rear of trunk, on inertia switch	151- 9- E9		GY	3
C414	Behind top center of rear seat, on lower relay	151- 14- F6	... 150-13	GR	5
C415	Behind top center of rear seat, on raise relay	151- 14- F6	... 150-20	GR	5
C416	Center rear of hatchback, on rear courtesy lamp switch	151- 12- D9		BK	2
C417 (2 Door)	In center rear of trunk lid, on trunk lid release solenoid	151- 9- C9		GY	1
C417 (Convertible)	Center rear of trunk lid, on trunk lid release solenoid	151- 14- D9		GY	1
C418	LH rear of car, on left rear turn lamp	151- 11- F9		BK	2
	LH rear of car, on left rear park/stop lamp	151- 11- F7		BK	3
	LH rear of car, on left rear side marker lamp	151- 11- F6		BK	2
	LH rear of car, on left backup lamp	151- 11- F8		BK	2
	RH rear of car, on right rear turn lamp	151- 11- D9		BK	2
	RH rear of car, on right rear side marker lamp	151- 11- C9		BK	2



BUY IT NOW!

Click Here To Order 







LOCATION INDEX 152-22

<u>Connector</u>	<u>Location</u>	<u>Page Zone</u>	<u>Connector Page</u>	<u>Color</u>	<u>Terminal</u>
C424	RH rear of car, on right rear park/stop lamp	151- 11- C9		BK	3
C425	RH rear of car, on right backup lamp	151- 11- D9		BK	2
C426 (2 Door And Convertible)	In center rear of trunk lid, on right license lamp	151- 11- E9		BK	2
C426 (3 Door)	In center rear of hatchback, on right license lamp	151- 13- E9		BK	2
C427 (2 Door And Convertible)	In center rear of trunk lid, on left license lamp	151- 11- E9		BK	2
C427 (3 Door)	In center rear of hatchback, on left license lamp	151- 13- F9		BK	2
C428 (2 Door)	In center rear of trunk lid, on luggage compartment lamp	151- 9- D9		BK	1
C428 (Convertible)	LH rear of trunk lid, on luggage compartment lamp	151- 14- F8		BK	1
C429	Center rear of cargo area, on cargo lamp	151- 12- D9		GY	2
C430	In center of rear spoiler, near hi mount stop lamp	151- 13- C9		GY	2
C431	Center rear of trunk lid, to hi mount stop lamp	151- 15- A8		GY	2
C502	In center of LH front door, on master window/door lock control switch	151- 11- D1	.. 150-24	BK	16
C503	In rear of LH front door, on left door lock motor	151- 11- E1		GY	2
C504	In lower front of LH front door, near left front window motor	151- 11- F3		GY	2
C505	In center of LH front door, on master window/door lock control switch	151- 15- C1	.. 150-24	BK	16
C508	In front of LH front door, on left door speaker	151- 10- D1		GY	2
C509	Top front of LH front door, on left power mirror	151- 11- C1		GY	3
C602	In center of RH front door, on right window/door lock control switch	151- 11- A6	.. 150-25	BK	10
C603	In rear of RH front door, on right door lock motor	151- 11- B4		GY	2
C604	In lower front of RH front door, near right front window motor	151- 11- B9		GY	2
C606	In center of RH front door, near right door lock switch	151- 11- A8	.. 150- 2	BR	6
C607	In front of RH front door, on right door speaker	151- 10- A5		GY	2
C608	Top front of RH door, on right power mirror	151- 11- A5		GY	3
C900	Center of windshield header, on map lamp	151- 15- A4		BK	3
	At RH vanity mirror, on right vanity mirror lamp	151- 9- A2		N	1
	At LH vanity mirror, on left vanity mirror lamp	151- 9- C1		N	1
	Center of roof, on map lamp	151- 9- A7		Y	1
	Center of roof, on dome lamp	151- 9- A5		GY	1
	Center of windshield header, on dome lamp	151- 9- A1		GY	2

100% SATISFACTION GUARANTEED

BUY IT NOW!

Click Here To Order

PayPal American Express Discover MasterCard VISA

152-23 LOCATION INDEX

<u>Connector</u>	<u>Location</u>	<u>Page Zone</u>	<u>Connector Page</u>	<u>Color</u>	<u>Terminal</u>
C1000	RH rear of engine compartment, on octane adjust shorting bar	151- 2- A4		BK	2
C1001	Lower LH front of engine, on oil pressure sender	151- 5- F6		BK	1
C1002	LH rear of engine, on oil pressure switch	151- 3- A5		BK	1
C1003	Lower LH side of engine, on power steering pressure switch	151- 1- F7		BK	2
C1004	Top RH side of engine, on primary coil (RH)	151- 2- C1		BK	3
C1005	Lower RH rear of engine, near right heated exhaust gas oxygen (HEGO) sensor	151- 5- C1		BK	4
C1006	Top RH front of engine, near radio noise capacitor	151- 2- E1		GY	1
C1007	Top RH front of engine, on secondary coil (LH)	151- 2- E1		BK	3
C1008 (2.3L)	In rear of LH front fender, on speed control servo	151- 3- A9	150-22		6
C1008 (5.0L)	In rear of LH front fender, on speed control servo	151- 4- A9	150-22		6
C1009 SPOUT Check Connector (2.3L)	Top LH front of engine, near distributorless ignition system (DIS) module	151- 2- D9		BK	2
C1009 SPOUT Check Connector (5.0L)	LH front of engine, taped to engine harness, near distributor	151- 4- F5		BK	2
C1011 Tach Service Connector	LH front of engine, near distributorless ignition system (DIS) module	151- 2- A6		BK	2
C1012	Center front of engine, on TFI ignition module	151- 4- F4	150-22	GY	6
C1013	RH rear of engine compartment, on thermactor air bypass (TAB) solenoid	151- 5- B1		BK	2
C1014	RH rear of engine compartment, on thermactor air diverter (TAD) solenoid	151- 5- A1		BK	2
C1015	Top RH side of engine, near throttle position sensor	151- 5- A4		BK	3
C1016	LH rear of transmission, on vehicle speed sensor (VSS)	151- 11- B1		W	2
C1018 (2.3L)	In front of LH fender, on windshield washer pump motor	151- 2- D9		BK	2
C1018 (5.0L)	In front of LH fender, on windshield washer pump motor	151- 5-D10		BK	2
C1019 Windshield Washer Pump Test Connector (2.3L)	Lower LH side of engine compartment, taped to main harness	151- 2- B9		GY	1
C1019 Windshield Washer Pump Test Connector (5.0L)	Lower LH side of engine compartment, taped to main harness	151- 5- C9		GY	1
C1020	RH side of engine compartment, on WOT cutout relay	151- 5- D1	150-26		5
C1021	Lower LH front of car, on left fog lamp	151- 5- F7			2
C1022	LH front of car, on left front side marker lamp	151- 3- F9		BK	2

100% SATISFACTION GUARANTEED

BUY IT NOW!

Click Here To Order

PayPal American Express Discover MasterCard VISA

LOCATION INDEX 152-24

<u>Connector</u>	<u>Location</u>	<u>Page Zone</u>	<u>Connector Page</u>	<u>Color</u>	<u>Terminal</u>
C1023	LH front of car, on left headlamp	151- 3- F9		BK	5
C1024	LH front of car, on left front park/turn lamp	151- 3- F8			3
C1025	Lower RH front of car, on right fog lamp	151- 5- F3			2
C1026	RH front of car, on right front side marker lamp	151- 3- E1		BK	2
C1027	RH front of car, on right headlamp	151- 3- F2		BK	5
C1028	RH front of car, on right front park/turn lamp	151- 3- F3			3
C1029	LH front of engine compartment, near headlamp	151- 5- F8		BK	2
C1030	RH front of engine compartment, near headlamp	151- 5- F3		BK	2
C1031	Top rear of engine, on throttle position sensor	151- 1- A5		BK	3
C1032	RH side of engine compartment, on canister purge solenoid	151- 1- C1		BK	2
C2001	Top RH side of steering column, on ignition switch	151- 7- A8	.. 150- 9	BK	11
C2002	Behind LH side of I/P, on interval governor	151- 8- F9		GY	10
C2004	Behind RH center of I/P, on LCD illumination relay	151- 7- A2	.. 150-13	GY	5
C2005	Behind top LH side of I/P, on main light switch	151- 7- B9	.. 150-13	GY	6
C2006	Below rear of center console, on park brake switch	151- 10- F6		N	1
C2007	Behind LH side of I/P, on rear window defrost control relay	151- 7- E9	.. 150-20	N	5
C2008	Top RH side of steering column, on shift lock actuator	151- 8- A7			3
C2009	In center of steering wheel, on steering column air bag	151- 6- F6			2
C2010	Center of steering column, near clockspring/slip ring assembly	151- 8- C9		GY	3
C2011	Behind LH side of I/P, on stop lamp switch	151- 7- F4		BK	2
C2012	Behind center of I/P, on turn signal flasher	151- 7- F3		BK	2
C2013	Behind center of I/P, on warning chime module	151- 7- D1	.. 150-23	W	10
C2014	Behind top of LH cowl panel, on window safety relay	151- 6- B1	.. 150-23	GR	5
C2015	Behind center of I/P, on blower motor switch	151- 7- A4		GY	4
C2016	RH side of I/P, on glove box lamp	151- 7- B1		BR	2
C2017	Behind center of I/P, on A/C-heater control illumination	151- 8- A3		BK	2
C2018	Top LH side of steering column, near steering wheel control switch	151- 7- D9		GY	3
	RH side of I/P, on trunk lid/hatchback release switch	151- 7- A1		GY	2
	Behind top LH side of I/P, on rear window defrost switch	151- 7- A7		GY	4
	Behind top LH side of I/P, on instrument panel dimming rheostat	151- 8- C9		BK	4
	Top LH side of I/P, on convertible top switch	151- 7- A7		GY	4

100% SATISFACTION GUARANTEED

BUY IT NOW!

Click Here To Order



152-25 LOCATION INDEX

<u>Connector</u>	<u>Location</u>	<u>Page Zone</u>	<u>Connector Page</u>	<u>Color</u>	<u>Terminal</u>
C2024	Behind top RH corner of I/P, on right dash speaker	151- 8- A2		GY	2
C2025	Behind top LH corner of I/P, on left dash speaker	151- 8- B9		GY	2
C2026	Top RH side of steering column, near ignition key warning switch	151- 7- A9		GY	1
C2027	RH side of engine compartment, on fuel pump relay	151- 9- F2	150- 4	GR	5
C2030	Behind center of I/P, near graphic equalizer	151- 8- F7	150- 4	GY	12
C2031	Behind center of I/P, on rear of radio	151- 8- F5	150-19		8

<u>Ground</u>	<u>Location</u>	<u>Page Zone</u>
G100 (2.3L)	LH side of engine compartment, on front of wheel well	151- 2- C9
G100 (5.0L)	LH side of engine compartment, on front of wheel well	151- 5-D10
G102 (2.3L)	Top front of LH fender apron	151- 3- F7
G102 (5.0L)	Top front of LH fender apron	151- 5-E10
G103 (2.3L)	Top front of RH fender apron	151- 3- E1
G103 (5.0L)	Top front of RH fender apron	151- 5- E1
G104 (2.3L)	Front of LH fender apron, near windshield washer fluid reservoir	151- 2- D9
G104 (5.0L)	Front of LH fender apron, near windshield washer fluid reservoir	151- 5-D10
G105 (2.3L)	Lower LH front of engine, below integral alternator regulator (IAR)	151- 2- F6
G105 (5.0L)	Lower LH front of engine, below A/C compressor assembly	151- 5- F6
G106	LH side of engine compartment, on front of wheel well	151- 2- C9
G109	RH rear of engine, below valve cover	151- 5- A5
G200	Behind center of I/P, on I/P support brace	151- 7- F5
G201	Behind RH cowl panel, below electronic engine control (EEC) module	151- 6-D10
G202	Behind center of I/P, on I/P support brace	151- 6- A5
G203	Behind center of I/P, on I/P support brace	151- 7- F5
	Below LH front seat	151- 10- F2
	Below rear of center console, on park brake assembly	151- 10- F6
	RH side of trunk, above wheel well	151- 9- A9
	In RH side of hatchback, below rear window	151- 12- B9
	Behind top center of rear seat, RH side of convertible top motor	151- 14- B9

100% SATISFACTION GUARANTEED

BUY IT NOW!

Click Here To Order

PayPal American Express Discover MasterCard VISA

LOCATION INDEX 152-26

<u>Ground</u>	<u>Location</u>	<u>Page</u> <u>Zone</u>
G400 (2 Door)	Center rear of trunk, LH side of latch striker	151- 9- E9
G400 (3 Door)	Center rear of cargo area	151- 12- F9
G400 (Convertible)	Center rear of trunk	151- 14- E9
G401 (2 Door)	LH side of trunk, above rear of wheel well	151- 9- F7
G401 (3 Door)	LH rear corner of hatchback	151- 12- F8
G401 (Convertible)	LH front of trunk, above wheel well	151- 15- F6
G402	Lower LH side of cargo area, behind wheel well	151- 13- F6
G500	In center of LH front door	151- 15- D1
G900	Center of windshield header	151- 9- B1

<u>Splice</u>	<u>Location</u>
S100	Main harness, near T/O to G100
S102	Engine harness, near T/O to VIP test connectors C198 and C199
S103	Dash panel to headlamp junction harness, near T/O to left headlamp
S104	Dash panel to headlamp junction harness, near T/O to G103
S105	Engine harness, at T/O to C113
S106	Engine harness, near T/O to fuse links G, H, and J
S107	Engine control sensor extension harness, in T/O to C101
S108	Dash panel to headlamp junction harness, near T/O to G102
S109	Main harness, near T/O to windshield washer pump test connector C1019
S110	Fuel charge harness, near T/O to fuel injector No. 2
S111	Main harness, near T/O to windshield washer pump test connector C1019
S112	Engine harness, near T/O to barometric absolute pressure (BAP) sensor
S113	Engine harness, near T/O to C101
S114	Engine control sensor extension harness, in T/O to C110
S116	Engine harness, near T/O to octane adjust shorting bar
	Engine control sensor extension harness, near T/O to C101
	Dash panel to headlamp junction harness, near T/O to G102
	Engine harness, near T/O to clutch cycling pressure switch
	Engine harness, near T/O to EEC power relay
	Engine control sensor extension harness, near T/O to oil pressure switch



BUY IT NOW!

Click Here To Order



152-27 LOCATION INDEX

<u>Splice</u>	<u>Location</u>
S121	Fuel charge harness, near T/O to EGR valve position sensor
S122	Fuel charge harness, near T/O to fuel injector No. 4
S123 (2.3L)	Engine harness, near T/O to barometric absolute pressure (BAP) sensor
S123 (5.0L)	Engine harness, near T/O to clutch cycling pressure switch
S124	Engine harness, near T/O to C119
S125	Engine control sensor extension harness, near T/O to SPOUT check connector C1009
S126	Engine control sensor extension harness, in T/O to C101
S127	Main harness, near T/O to fuse link N
S128	Fuel charge harness, near T/O to C119
S129	Main harness, near T/O to windshield washer pump test connector C1019
S130	Dash panel to headlamp junction harness, near T/O to G102
S131	Engine control sensor extension harness, near T/O to C105
S132	Engine harness, near T/O to VIP test connectors C198 and C199
S133	Dash panel to headlamp junction harness, near T/O to low coolant switch
S134	Engine control sensor extension harness, near T/O to SPOUT check connector C1009
S135	Engine control sensor extension harness, near T/O to C1034
S136	Engine harness, near T/O to integrated control module
S137	Engine harness, near T/O to integrated control module
S138	Engine harness, near T/O to octane adjust shorting bar
S140	Dash panel to headlamp junction harness, near T/O to integral alternator regulator (IAR)
S200	Main harness, near T/O to fuse panel
S201	Main harness, at T/O to low oil warning relay
S204	Main harness, near T/O to fuse panel
S205 (With Graphic Equalizer)	Radio power booster and equalizer amplifier harness, near T/O to G203
S205 (Without Graphic Equalizer)	Radio speaker jumper harness, near T/O to radio
S206	Main harness, near T/O instrument cluster, connector C251
S207	Main harness, near T/O to fuse panel
S208	Main harness, near T/O to C251
S209	Main harness, near T/O to ignition switch
S210	Main harness, near T/O to fuse panel
S211	Main harness, near T/O to blower motor switch
S212	Main harness, near T/O to fuse panel
S213	Main harness, near T/O to clutch interrupt switch

100% SATISFACTION GUARANTEED

BUY IT NOW!

Click Here To Order

PayPal American Express Discover MasterCard VISA

<u>Splice</u>	<u>Location</u>
S217	Engine harness, near T/O to electronic engine control (EEC) module
S218	Main harness, near T/O to low oil warning relay
S220	Main harness, near T/O to C251
S221	Main harness, near T/O to blower motor resistor assembly
S222	Main harness, near T/O to ignition switch
S223	Main harness, near T/O to C251
S224	Window regulator relay switch harness, near T/O to C221
S225 (2 And 3 Door)	Window regulator relay switch harness, near T/O to C221
S225 (Convertible)	Window regulator relay switch harness, near T/O to C225
S226	Main harness, at T/O to low oil warning relay
S227	Main harness, at T/O to low oil warning relay
S228	Main harness, near T/O to C213
S229	Main harness, near T/O to blower motor resistor assembly
S230 (With Graphic Equalizer)	Radio power booster and equalizer amplifier harness, near T/O to G203
S230 (Without Graphic Equalizer)	Radio speaker jumper harness, near T/O to radio
S231	Window regulator left front harness, near T/O to C227
S233	Main harness, in T/O to fuse panel
S237	Main harness, near T/O to C251
S300	Rear lamp harness, near T/O to G300
S301	Rear lamp harness, near T/O to convertible top motor
S302	Seat switch and wire assembly, near T/O to C304
S303 (With Moonroof)	Interior lamp harness, near T/O to dome lamp
S303 (Without Moonroof)	Interior lamp feed harness, near T/O to right vanity mirror lamp
S304	Rear lamp harness, near T/O to G300
S305	Rear lamp harness, near T/O to C309
S306	Seat switch and wire assembly, near T/O to C304
S400	Rear lamp harness, near T/O to right backup lamp
S401	Rear lamp harness, near T/O to left rear park/stop lamp
Door And Convertible)	Luggage compartment lamp harness, near T/O to left license lamp
	Rear license lamp harness, near T/O to C401
	Rear lamp harness, near T/O to right rear turn lamp
	Luggage compartment lamp harness, near T/O to left license lamp
	Rear lamp harness, near T/O to C403

100% SATISFACTION GUARANTEED

BUY IT NOW!

Click Here To Order



152-29 LOCATION INDEX

<u>Splice</u>	<u>Location</u>
S411	Rear lamp harness, near T/O to left backup lamp
S412	Rear lamp harness, near T/O to left rear park/stop lamp
S500	Window regulator left front door harness, near T/O to master window/door lock control switch
S501	Window regulator left front door harness, near T/O to master window/door lock control switch
S600 (With Power Windows)	Window regulator right front door harness, near T/O to right window/door lock control switch
S600 (Without Power Windows)	Right front door lock harness, near T/O to C606
S601 (With Power Windows)	Window regulator right front door harness, near T/O to right window/door lock control switch
S601 (Without Power Windows)	Right front door lock harness, near T/O to C606



BUY IT NOW!
Click Here To Order 



160-1 VEHICLE REPAIR LOCATION CODES

VEHICLE REPAIR LOCATION CODES

TO PINPOINT THE ACTUAL VEHICLE LOCATION OF A REPAIR, THE VEHICLE REPAIR LOCATION CODE IS REQUIRED.

FOR EXAMPLE, AN "X" HAS BEEN PLACED IN THE QUADRANT OF THE VEHICLE DIAGRAMS INDICATING THE LOCATION OF THE REPAIR. SEE DIAGRAMS.

LOCATION CODE, FOR THE EXAMPLE IS: A5/FU — (UNDER THE FLOOR OF DRIVER'S LEFT FOOT.)

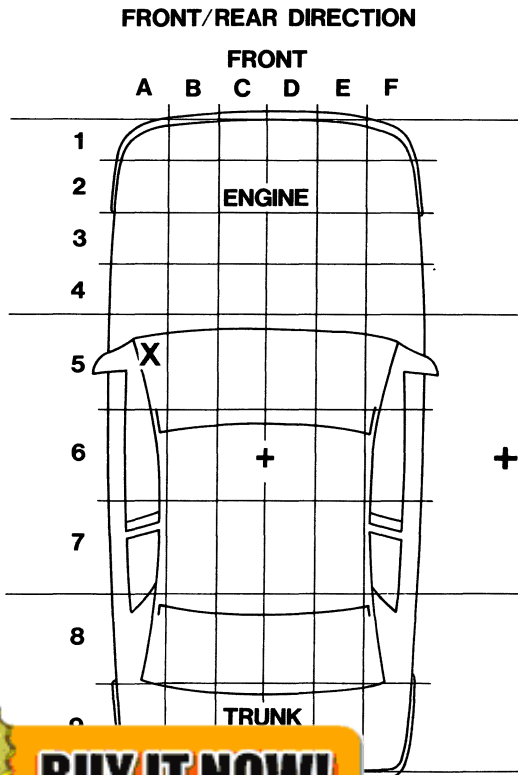

+ CENTER OF VEHICLE

OVER/UNDER DIRECTION

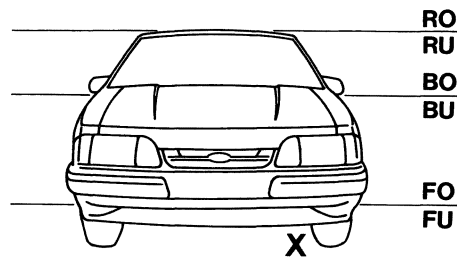

R = ROOF LINE
 RO = ROOF OVER
 RU = ROOF UNDER
 B = BELT LINE
 BO = BELT OVER
 BU = BELT UNDER
 F = FLOOR PAN
 FO = FLOOR OVER
 FU = FLOOR UNDER

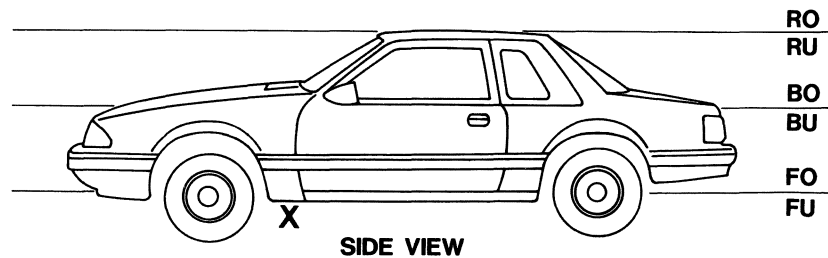

BUY IT NOW!

Click Here To Order



We Want To Hear From You!

Tell us about yourself

Are you a: Ford Trained Technician Independent Technician Customer
 Other _____

1. Which section of the EVTMM do you use most frequently?

Schematics Diagnostics Component Location Information

2. How often do you refer to this Ford Service Publication?

For all electrical problems
 For about 75% of electrical problems
 Fewer than 25% of electrical problems

3. Do the component location descriptions provide enough detail?

Yes No

Suggestions: _____

4. Would you prefer to have the electrical information for one vehicle, in one publication (separate electrical publications for each vehicle)?

Yes No

5. Are connector views and corresponding information helpful when diagnosing electrical problems?

Yes No

6. Would you like to include more component switch test information?

Yes No

7. Do you read the "How to Use this Manual" and "How to Find the Electrical Concerns" sections of this manual?

Yes No

What additional information would be helpful? _____

8. Rate the purpose for using the location index. (5 is high, 1 is low)

Connectors Splices Part Numbers Grounds

9. Are the full view, more comprehensive illustrations (located just prior to the Location Index) a helpful tool?

Yes No

Comment: _____

10. Please rate the overall effectiveness of the revised radio schematics and diagnostics.

Good Fair Poor

11. How helpful are the "equivalent circuits" of electrical components, as shown on schematics, when troubleshooting electrical circuits?

Fair Poor

Comments: _____



BUY IT NOW!

Click Here To Order



DO NOT STAPLE – USE TRANSPARENT TAPE



NO POSTAGE
NECESSARY
IF MAILED
IN THE
UNITED STATES

BUSINESS REPLY MAIL
FIRST CLASS PERMIT NO. 400 DEARBORN, MICH.

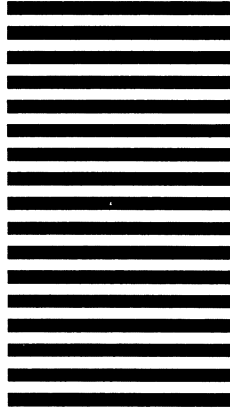

POSTAGE WILL BE PAID BY ADDRESSEE

Ford Parts and Service Division
Service Publications-SWP
Room 2009
Post Office Box 1902
3000 Schaefer Road
Dearborn, Michigan 48121



BUY IT NOW!
Click Here To Order 





**WE SUPPORT VOLUNTARY
TECHNICIAN CERTIFICATION**



**TECHNICAL
PUBLICATION DEPARTMENT**
Ford Parts and Service Division

100% SATISFACTION GUARANTEED

BUY IT NOW!

Click Here To Order

PayPal American Express Discover MasterCard VISA

FPS-12121-92
Copyright © 1991
Ford Motor Company