

**100% MONEY BACK GUARANTEE**

**BUY IT NOW!**

**Click Here To Order**

# 2 ONCO / F150-F350 UPER DUTY

[Buy Now](#)



**DEMO**

This DEMO contains only a few pages of the entire manual/product.

Not all Bookmarks work on the Demo, but they do on the full version.

**Features:**

- Searchable text
- Printable pages
- Bookmarked for easy navigation
- High Resolution images
- Zoom to see exact details
- Money back Guarantee
- Available on USB and eBook download



**Electrical &  
Vacuum  
Trouble-  
Shooting  
Manual**



License #84356800

Copyright © 2024, Forel Publishing Company, LLC, Woodbridge, Virginia

All Rights Reserved. No part of this book may be used or reproduced in any manner whatsoever without written permission of Forel Publishing Company, LLC. For information write to Forel Publishing Company, LLC, Woodbridge, VA 22192

**1992 Bronco/F150-F350/F-Super Duty Electrical &  
Vacuum Trouble-Shooting Manual (EVTM)**

**EAN: 978-1-60371-416-7**

**ISBN: 1-60371-416-2**

Forel Publishing Company, LLC  
Woodbridge, VA 22192  
Email: [sales@ForelPublishing.com](mailto:sales@ForelPublishing.com)  
<https://www.ForelPublishing.com>



This publication contains material that is reproduced and distributed under a license from Ford Motor Company. No further reproduction or distribution of the Ford Motor Company material is allowed without the express written permission of Ford Motor Company.

---

## Note from the Publisher

This product was created from the original Ford Motor Company's publication. Every effort has been made to use the original scanned images, however, due to the condition of the material; some pages have been modified to remove imperfections.

---

## Disclaimer

Although every effort was made to ensure the accuracy of this book, no representations or warranties of any kind are made concerning the accuracy, completeness or suitability of the information, either expressed or implied. As a result, the information contained within this book should be used as general information only. The author and Forel Publishing Company, LLC shall have neither liability nor responsibility to any person or entity with respect to any loss or damage caused, or alleged to be caused, directly or indirectly by the information contained in this book. Further, the publisher and author are not engaged in rendering legal or other professional services. If legal, mechanical, electrical, or other expert assistance is required, the professional should be sought.



# 1992 BRONCO/F150-F350/F SUPER DUTY

## ELECTRICAL AND VACUUM TROUBLESHOOTING MANUAL FPS-12129-92

FORD PARTS and SERVICE DIVISION

### Quality is Job 1

Ford Parts and Service Division has developed a new format for the EVTVM for the 1992 Bronco F. Our goal is to provide accurate and timely electrical and vacuum service information.

### 1992 EVTVM FEATURES

- **"HOW THE CIRCUIT WORKS"** descriptions that explain how each circuit works. These descriptions are designed to be used in conjunction with the Electrical Schematic.
- **Schematic pages** now contain **COMPONENT LOCATION** references to full-view illustrations.
- **"COMPONENT TESTING"** procedures (CELL 149) that tell the user how to perform diagnostic tests on various circuits.
- **Connector End Views** (**"COMPONENT CONNECTOR FACES"** CELL 150) are shown for connectors with five or more cavities; and for connectors with ten or more cavities, a circuit function chart is provided.
- **NOTES, CAUTIONS and WARNINGS** that contain important safety information.
- Full view **"COMPONENT LOCATION VIEWS"** (CELL 151) to help locate on-vehicle components.
- **Component Base Part Numbers** and **Harness Base Part Numbers** to aid in ordering parts.
- **Cellular Pagination:** A specific section (or cell) in all EVTVMs is numbered by cell and starts with page 1. For example: **"HOW TO USE THIS MANUAL"** is CELL 2 and begins with page 2-1.

"C" numbers are listed for all electrical connectors. "C" numbers are listed in numerical order in the **"LOCATION INDEX"**

"ou" - A feedback sheet is provided on the last page.

### ORDERING INFORMATION

Information about how to order additional copies of this publication or other Ford publications may be obtained by writing to Helm Incorporated at the address shown below or by calling 1-800-782-4356. Other publications available include:

- Shop Manuals
- Service Specification Books
- Car/Truck Wiring Diagrams
- Powertrain Control/Emissions Diagnosis Manuals

Helm Incorporated  
P.O. Box 87150  
Detroit, Michigan 48207

**SATISFACTION 100% GUARANTEED**

**BUY IT NOW!**

**Click Here To Order**

PayPal American Express Discover MasterCard VISA

# 1-1 TABLE OF CONTENTS/INDEX

## Table Of Contents

How to Use This Manual .....	2-1
Troubleshooting/Descriptions .....	7-1
Grounds .....	10-1
Circuit Protection/Fuse Panel .....	11-1
Charging System .....	12-1
Power Distribution .....	13-1
Starting System .....	20-1
Ignition System .....	21-1
Electronic Engine Control (4.9L EFI)	23-1
Electronic Engine Control (5.0L and 5.8L EFI) .....	24-1
Electronic Engine Control (7.5L EFI)	25-1
Glow Plug Control .....	26-1
E4OD Transmission (Diesel) .....	29-1
E4OD Transmission (Gasoline) .....	30-1
Speed Control .....	31-1
Electronic Shift Control .....	34-1
All Wheel Drive .....	34-1
Anti-lock Brakes .....	42-1
Horn/Cigar Lighter .....	44-1
Fuel Tank Selector .....	49-1
Heater .....	53-1
Air Conditioner/Heater .....	54-1
Rear Window Defrost .....	56-1
Instrument Cluster .....	60-1
Vehicle Speed Signal .....	64-1
Warning Indicators .....	65-1
Warning Chime .....	66-1
Instrument Illumination .....	71-1
Interval Wiper/Washer .....	81-1
Headlamps .....	85-1
Courtesy Lamps .....	89-1
Stop/Hazard Lamps .....	90-1
Daytime Running Lamps .....	92-1
Electronic Engine Control	93-1
4.9L .....	95-1
5.0L & 5.8L .....	97-1
7.5L .....	100-1

Power Door Locks .....	110-1
Power Lumbar Seats .....	122-1
Power Mirrors .....	124-1
Radio .....	130-1
Vacuum Distribution .....	142-1
Component Testing .....	149-1
Connector Faces .....	150-1
Component Location Views .....	151-1
Location Index .....	152-1
Vehicle Repair Location Codes .....	160-1

## Index

Anti-lock Brakes .....	42-1
A/C-Heater	
Vacuum .....	54-1
Electrical .....	54-2
Charging System .....	12-1
Cigar Lighter .....	44-1
Circuit Protection/Fuse Panel .....	11-1
Component Testing	
A/C Function Selector Switch .....	149-7
Backup/Neutral Safety Switch .....	149-11
Blower Switch .....	149-8
Heater Function Selector Switch .....	149-6
Ignition Switch .....	149-2
Introduction .....	149-1
Main Light Switch .....	149-1
Manual Lever Position Sensor .....	149-10
Multi-function Switch .....	149-3 to 149-5
Tank Selector Valve .....	149-9
Connector Faces/Pinout Charts .....	150-1
Courtesy Lamps .....	89-1
Daytime Running Lamps .....	97-1
Electronic Engine Control	
4.9L .....	23-1
5.0L & 5.8L .....	24-1

7.5L .....	25-1
Electronic Shift Control .....	34-1
E4OD Transmission	
Diesel .....	29-1
Gas .....	30-1
Fuel Tank Selector	
Diesel .....	49-1
Gas .....	49-2
Fuse Panel	
Diesel .....	13-9
Gas .....	13-3
Fuse 1 .....	13-15
C.B. 2 .....	13-19
Fuse 4 .....	13-18
Fuse 6 .....	13-19
Fuse 7 .....	13-15
Fuse 8 .....	13-17
Fuse 9 .....	13-12
Fuse 10 .....	71-1
Fuse 11 .....	13-19
C.B. 12 .....	13-13
Fuse 13 .....	13-12
C.B. 14 .....	13-19
Fuse 15 .....	13-15
Fuse 16 .....	13-18
Fuse 17 .....	13-16
Fuse 18 .....	13-15
Gauges	
Coolant Temperature .....	60-1
Fuel .....	60-1
Oil Pressure .....	60-1
Tachometer .....	60-4
Voltmeter .....	60-1
Glow Plug Control .....	26-1
Grounds	
G100	
Diesel .....	10-5



# 2-1 HOW TO USE THIS MANUAL

1992 BRONCO F-SERIES

The purpose of this manual is to show electrical and vacuum circuits in a clear and simple fashion to make troubleshooting easier. **NOTES**, **CAUTIONS** and **WARNINGS** containing important information appear in boxes on text pages.

- **NOTES** describe how switches and other components operate to help complete a particular procedure.
- **CAUTIONS** provide information that could prevent making an error that may damage the vehicle.
- **WARNINGS** provide information to prevent personal injury.

The **WARNINGS** list on page 2-2 contains general warnings to follow when servicing a vehicle.

Components that work together are shown together. All electrical components used in a specific system are shown on one diagram. The circuit breaker or fuse is shown at the top of the page. All wires, connectors, components and splices are shown in the flow of current to ground at the bottom of the page. If a component is used in several different systems, it is shown in several places. For example, the Main Light Switch is electrically a part of many systems and is repeated on many pages.

In some cases, a component may seem (by its name) to belong to a system where it has no electrical connection. For example, Radio Illumination is electrically part of Instrument Illumination, but because it has no electrical connection to the Radio system, it is not shown on the Radio diagram.

Schematic pages now contain references to wiring illustrations. These references are relevant to each component and refer to the appropriate

circuit voltages

to help simplify troubleshooting hints. 12V is used to imply battery voltage on a component connector terminal, and 0V is used to show that there should be continuity to ground on that particular terminal. Conditional voltages such as "12V with the ignition switch in RUN" will also be provided. Troubleshooting hints that can't be simplified with circuit voltages will be shown at the end of each cell.

Connector face information specific to a certain cell is now found at the end of that cell. A Connector Face Reference List is provided to locate connector faces that are shown in different cells. Component connectors with five or more terminals are illustrated. Component connectors with ten or more terminals are accompanied by a pinout chart that lists the function of all circuitry associated with that component.

"**CIRCUIT OPERATION**" (Cell 7) contains descriptions of HOW THE CIRCUIT WORKS for each system as well as reference to the appropriate diagnostic section of the Service Manual. The beginning of each section has a reverse-text block identifying the page on which the corresponding schematic appears.

"**GROUND**" (Cell 10) contains ground circuitry shown in complete detail. This information is useful for checking interconnections of the ground circuits of different systems.

"**POWER DISTRIBUTION**" (Cell 13) contains power distribution circuitry shown in complete detail. This section displays how the various fuses are powered and in turn, how each system is powered.

"**COMPONENT TESTING**" (Cell 149) contains testing procedures for various switches. This information includes schematics, component terminal locations and step-by-step procedures.

"**COMPONENT LOCATION VIEWS**" (Cell 151) contains full-view illustrations which show the location of all components and connectors in the vehicle.

The "**LOCATION INDEX**" (Cell 152) provides the base part numbers, locations, connector face references and illustration references for all components, connectors, splices and grounds.

## HELPFUL REMINDERS

Before using the EVTM for troubleshooting, refer to the HELPFUL REMINDERS;

1. The abbreviation T/O, for take out, used in the Location Index (Cell 152), refers to the point at which a group of wires branch off the harness trunk. Refer to the wiring harness illustration.

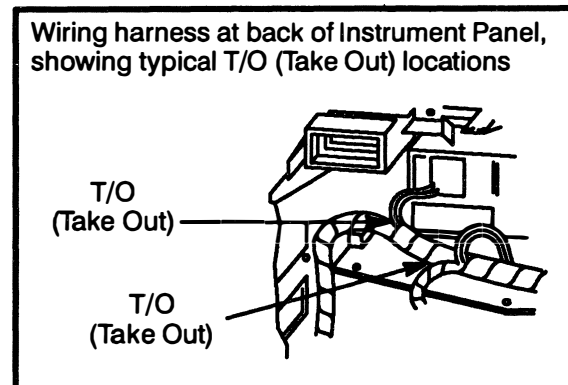

2. If a connector serves the same purpose in two separate versions (e.g., EFI/Carb), but is physically different, *two* connector numbers are used. However, if a connector serves the same purpose in two separate versions (e.g., EFI/Carb) and is physically the same, but the wire colors are different, only *one* connector number is used. If the same physical connector is used more than once, then more than *one* connector number is used.

**100% SATISFACTION GUARANTEED**

**BUY IT NOW!**

**Click Here To Order**

PayPal   American Express   Discover   MasterCard   VISA

## HELPFUL REMINDERS (CONTINUED)

are different, only *one* connector number is used. If the same physical connector is used more than once, then more than *one* connector number is used.

- Wiring diagrams provide a schematic picture of how and under what conditions the circuit is powered, of the current path to circuit components, and of how a circuit is grounded. Each circuit component is named (underlined titles). Wire and connector colors are listed (standard Ford color abbreviations are used):

### COLOR ABBREVIATIONS

BL	Blue	N	Natural
BK	Black	O	Orange
BR	Brown	PK	Pink
DB	Dark Blue	P	Purple
DG	Dark Green	R	Red
GR	Green	T	Tan
GY	Gray	W	White
LB	Light Blue	Y	Yellow
LG	Light Green		

**Note:** Whenever a wire is labeled with two colors, the first color listed is the basic color of the wire, and the second color listed is the stripe marking of the wire.

- When reporting Vehicle Repair Location Codes to Ford Parts and Service Division, refer to Cell 160 (beginning on page 151-1) for illustrations and Location Codes.

## 5. WARNINGS

- *Always wear safety glasses for eye protection.*
- *Use safety stands whenever a procedure requires being under a vehicle.*
- *Be sure that the Ignition Switch is always in the OFF position, unless otherwise required by the procedure.*
- *Set the park brake when working on any vehicle. An automatic transmission should be in PARK. A manual transmission should be in NEUTRAL.*
- *Operate the engine only in a well-ventilated area to avoid danger of carbon monoxide.*
- *Keep away from moving parts, especially the fan and belts, when the engine is running.*
- *To prevent serious burns, avoid contact with hot metal parts such as the radiator, exhaust manifold, tail pipe, catalytic converter and muffler.*
- *Do not allow flame or sparks near the battery. Gases are always present in and around the battery cell. An explosion could occur.*
- *Do not smoke.*
- *To avoid injury, always remove rings, watches, loose hanging jewelry and loose clothing.*

## HOW TO FIND ELECTRICAL CONCERNS

### TROUBLESHOOTING STEPS

These six steps present an orderly method of troubleshooting.

#### Step 1. Verify the concern.

- Operate the complete system to check the accuracy and completeness of the customer's complaint.

#### Step 2. Narrow the concern.

- Using the EVTM, narrow down the possible causes and locations of the concern to pinpoint the exact cause.
- Read the description of *How the Circuit Works* and study the wiring diagram. You should then know enough about the circuit operation to determine where to check for the trouble. Further information can be found in the Shop Manual pages listed after *How the Circuit Works*.

#### Step 3. Test the cause.

- Use electrical test procedures to find the specific cause of the symptoms.
- *Troubleshooting Hints* will give you helpful ideas.
- The *Component Location Charts* and the pictures will help you find components. Following each chart, there is a reference to the Location Index at the end of the manual. This index gives component location information for connectors, diodes, resistors, splices and grounds.

#### Step 4. Verify the cause.

- Confirm that you have found the correct cause by connecting jumper wires and/or temporarily installing a known good component and operating the circuit.

**100% SATISFACTION GUARANTEED**

**BUY IT NOW!**

**Click Here To Order**



# 2-3 HOW TO USE THIS MANUAL

## HOW TO FIND ELECTRICAL CONCERNS

### Step 5. Make the repair.

- Repair or replace the inoperative component.

### Step 6. Verify the repair.

- Operate the system as in Step 1 and check that your repair has removed all symptoms without creating any new symptoms.

Some engine circuits may need special test equipment and special procedures. See the *Shop Manual* and other service books for details. You will find these circuits in this manual to be helpful with these special tests.

## TROUBLESHOOTING TOOLS

### JUMPER WIRE

This is a test lead used to connect two points of a circuit. A Jumper Wire can complete a circuit, bypassing an open.

### WARNING

Never use a jumper wire across loads (motors, etc.) connected between hot and ground. This direct battery short may cause injury or fire.

### VOLTMETER

A DC Voltmeter measures circuit voltage. Connect negative (- or black) lead to ground, and positive (+ or red) lead to the voltage measurement point.

### OHMMETER

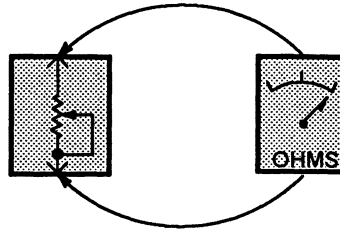

Figure 1—Resistance Check

An Ohmmeter shows the resistance between two connected points (Figure 1).

### TEST LAMP

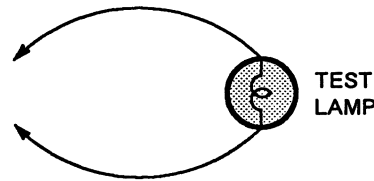

Figure 2—Test Lamp

A Test Light is a 12-volt bulb with two test leads (Figure 2).

Uses: Voltage Check, Short Check.

### SELF-POWERED TEST LAMP

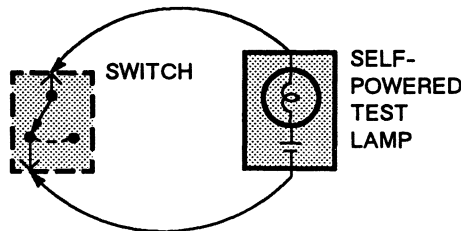

Figure 3—Continuity Check

The Self-Powered Test Lamp is a bulb, battery and set of test leads wired in series (Figure 3). When connected to two points of a continuous circuit, the bulb glows.

Uses: Continuity Check, Ground Check.

### CAUTION

When using a self-powered test lamp or ohmmeter, be sure power is off in circuit during testing. Hot circuits can cause equipment damage and false readings.

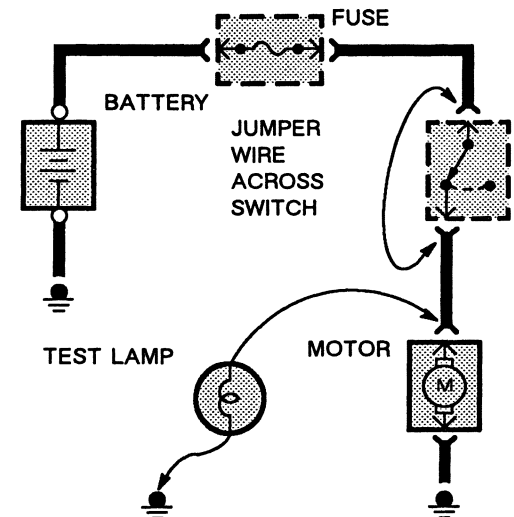

Figure 4—Switch Circuit Check and Voltage Check

In an inoperative circuit with a switch in series with the load, jumper the terminals of the switch to power the load. If jumpering the terminals powers the circuit, the switch is inoperative (Figure 4).

**100% SATISFACTION GUARANTEED**

**BUY IT NOW!**

**Click Here To Order**

PayPal    American Express    Discover    MasterCard    VISA

## HOW TO FIND ELECTRICAL CONCERNS (CONTINUED)

### CONTINUITY CHECK

(Locating open circuits)

Connect one lead of Self-Powered Test Lamp or Ohmmeter to each end of circuit (Figure 3). Lamp will glow if circuit is closed. Switches and fuses can be checked in the same way.

### VOLTAGE CHECK

Connect one lead of test lamp to a known good ground or the negative (-) battery terminal. Test for voltage by touching the other lead to the test point. Bulb goes on when the test point has voltage (Figure 4).

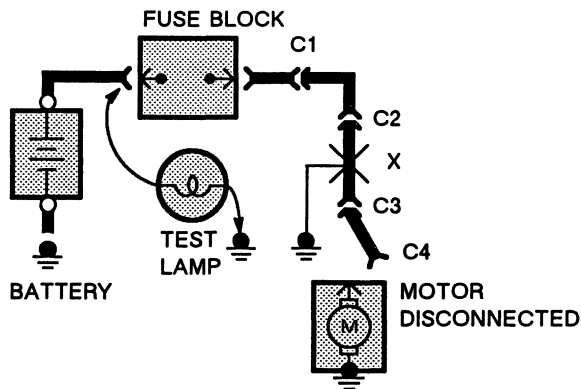

Figure 5—Short Check

A fuse that repeatedly blows is usually caused by a short to ground. It's important to be able to locate such a short quickly (Figure

**100% SATISFACTION GUARANTEED**

**BUY IT NOW!**

**Click Here To Order**

through the

ed through

- Motors: disconnect motor connector (Connector C4 in Figure 5).
  - Lights: remove bulbs.
3. Turn Ignition Switch to RUN (if necessary) to power fuse.
  4. Connect one Test Lamp lead to hot end of blown fuse. Connect other lead to ground. Bulb should glow, showing power to fuse. *(This step is just a check to be sure you have power to the circuit.)*
  5. Disconnect the test lamp lead that is connected to ground, and reconnect it to the load side of the fuse at the connector of the disconnected component. (In Figure 5, connect the test lamp lead to connector C4.)
    - If the Test Lamp is off, the short is in the disconnected component.
    - If the Test Lamp goes on, the short is in the wiring. You must find the short by disconnecting the circuit connectors, one at a time, until the Test Lamp goes out. For example, in Figure 5 with a ground at X, the bulb goes out when C1 or C2 is disconnected, but after disconnecting C3. This means the short is between C2 and C3.

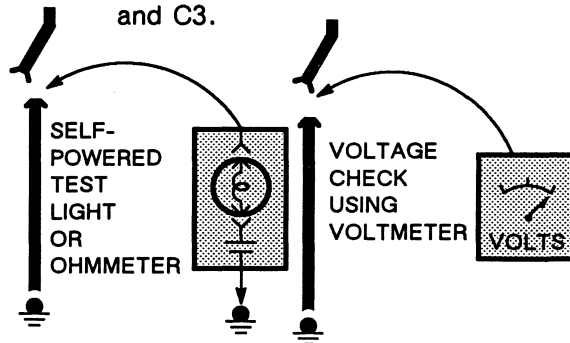

Figure 6—Ground Check

Turn on power to the circuit. Perform a Voltage Check between the suspected inoperative ground and the frame. Any indicated voltage means that the ground is inoperative (Figure 6).

Turn power to the circuit. Connect one lead of a Self-Powered Test Lamp or Ohmmeter to the wire in question and the other lead to a known ground. If the bulb glows, the circuit ground is OK (Figure 6).

## TROUBLESHOOTING HINTS

The circuit schematics in this manual make it easy to identify common points in circuits. This knowledge can help narrow the concern to a specific area. For example, if several circuits fail at the same time, check for a common power or ground connection (see *Power Distribution or Grounds*). If part of a circuit fails, check the connections between the part that works and the part that doesn't work.

For example, if low beam headlamps work, but high beams and the indicator lamp don't work, then power and ground paths must be good. Since the dimmer switch is the component that switches this power to the high beam lights and indicator, it is most likely the cause of failure.

Troubleshooting Hints unique to a particular circuit are given in a three column format. Included in the charts are conditions that may develop, possible causes, and one or more tests that can be done quickly to determine the cause of the condition.

## 2-5 HOW TO USE THIS MANUAL

### HOW TO FIND THE VACUUM CONCERNS

These six steps present an orderly method of troubleshooting.

#### Step 1. Verify the concern.

- Operate the system and observe all symptoms to check the accuracy and completeness of the customer's complaint.

#### Step 2. Narrow the concern.

- Using the EVTMM, narrow down the possible causes and locations of the concern to pinpoint the exact cause.

#### Step 3. Test the cause.

- Use test procedures to find the specific cause of the symptoms.

#### Step 4. Verify the cause.

- Confirm that you have found the right cause by operating the parts of the circuit you think are good.

#### Step 5. Make the repair.

- Repair or replace the inoperative component.

#### Step 6. Verify the repair.

- Operate the system as in Step 1. Check that your repair has removed all symptoms without creating any new symptoms.

**NOTE: Vacuum system problems fall into three groups.**

Leaks in hoses, connectors or motor



**BUY IT NOW!**

**Click Here To Order**

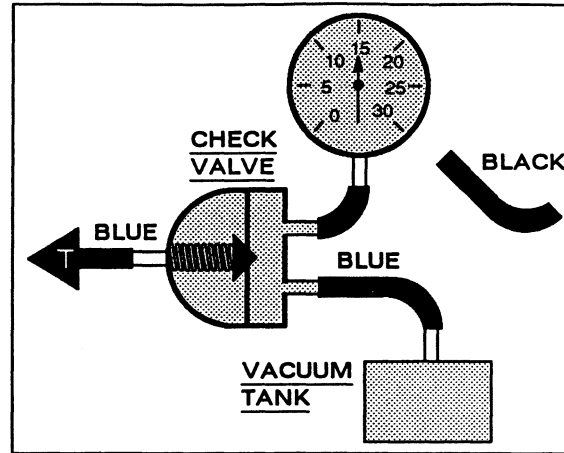

Figure 1 - System Supply Test

#### Vacuum Supply Test

1. Connect Vacuum Tester to system side of Check Valve (Figure 1).
2. Start engine. Gauge should show approximately 15 inches of vacuum.
3. Turn off engine, and observe gauge:
  - If vacuum holds, supply OK.
  - If vacuum fails, replace Check Valve or Tank.

#### Leak Test

1. Connect Vacuum Gauge and Vacuum Pump (Figure 2) to system hose in place of tank.
2. Open valve and start pump. Operate control in all modes.
3. Listen for hiss and observe gauge.

**NOTE: Hissing is normal at Function Control when changing modes.**

If system hisses or loses vacuum, find system leak as follows:

1. Turn on Vacuum Pump and check vacuum build-up.
2. Stop pump; vacuum should drop.
3. Clamp supply hoses with needlenose pliers, one at a time, until vacuum stops dropping (Figure 2).
4. Check vacuum schematic to find components in that line.
5. Clamp hoses through circuit to find leak.

#### Component Test

1. Connect Vacuum Tester to component.
2. Pump Vacuum Tester. Check that all components operate correctly and vacuum holds.
3. Replace component if vacuum does not hold.

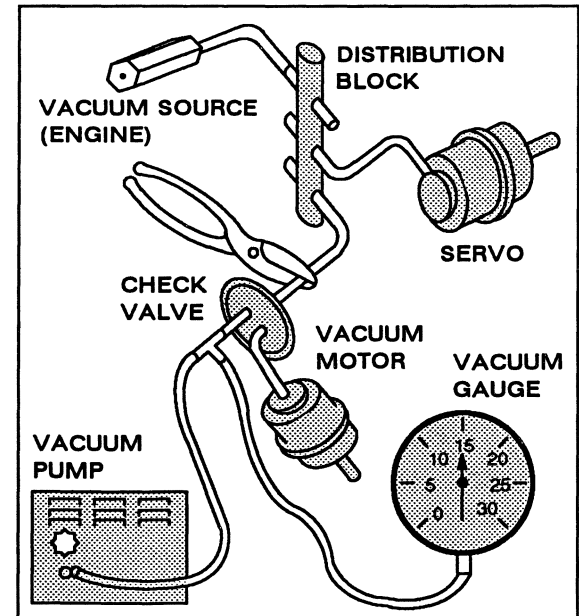
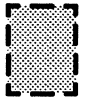

Figure 2 - Testing For Leaks In Typical Vacuum System

## ELECTRICAL SYMBOLS



**DASHED COMPONENT BOX**  
ONLY PART OF THE COMPONENT IS SHOWN ON THE PAGE; THE COMPONENT IS SHOWN COMPLETE IN ANOTHER LOCATION



**COMPONENT WITH CONNECTORS**

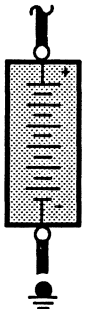

**BATTERY**

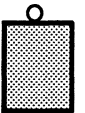

**SCREW TERMINAL ON COMPONENT**

**SOLID STATE**

**SEALED ELECTRONIC COMPONENT**  
ANY CIRCUITRY SHOWN INSIDE THE BOX IS A FUNCTIONAL EQUIVALENT ONLY

**100% SATISFACTION GUARANTEED**

**BUY IT NOW!**

**Click Here To Order**

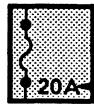

**FUSE**  
CURRENT RATING

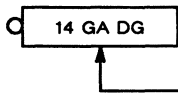

**FUSIBLE LINK**  
WIRE SIZE AND COLOR



**FUSIBLE LINK CARTRIDGE**  
CARTRIDGE CURRENT RATING

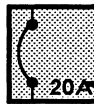

**CIRCUIT BREAKER**  
CURRENT RATING

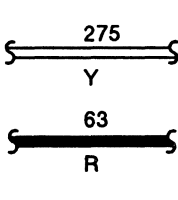

**SOLID WIRES**

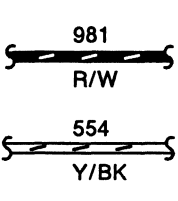

**STRIPED WIRES**

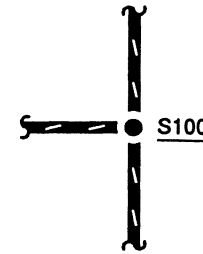

**SPLICE OR CRIMP TERMINAL**

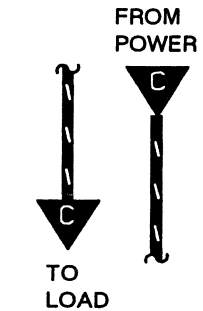

**"CUT" WIRES REFERENCED BETWEEN PAGES**  
ARROWS SHOW CURRENT FLOW FROM POWER TO GROUND



**"REFERENCE" WIRES**  
COMPLETE WIRING SHOWN ON ANOTHER PAGE

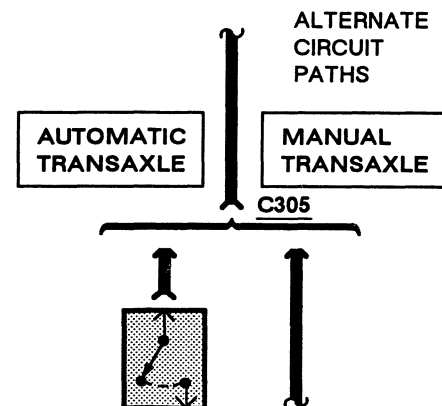

**ALTERNATE CIRCUIT PATHS**

# 2-7 HOW TO USE THIS MANUAL

## ELECTRICAL SYMBOLS

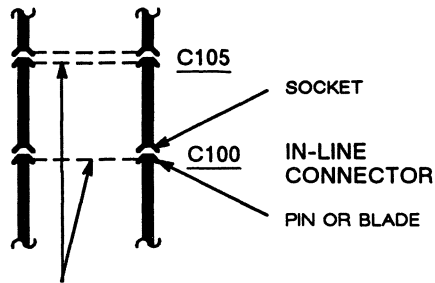

SINGLE OR DOUBLE DASHED LINE INDICATES THAT WIRE ON LEFT ALSO PASSES THROUGH THE SAME CONNECTOR

SEE GROUNDS  
PAGES 10-1,  
10-2

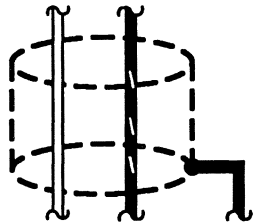
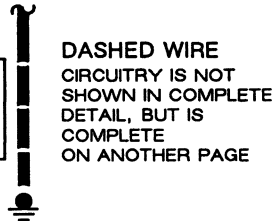

FIELD COIL  
OR



MOTOR



HEATING  
ELEMENT



THERMISTOR



RHEOSTAT  
OR  
POTENTIOMETER



SOLENOID



SWITCH

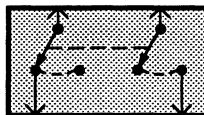

GANGED  
SWITCHES  
CONTACTS MOVE  
AT THE SAME TIME



DIODES  
CURRENT FLOWS  
IN DIRECTION OF  
ARROW ONLY



CAPACITOR



TRANSISTOR

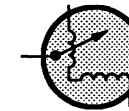

GAUGE



LIGHT  
BULB

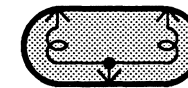

DUAL FILAMENT  
LIGHT BULB

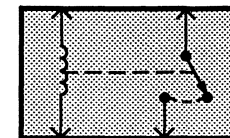

RELAY  
CONTACTS  
CHANGE POSITION  
WITH CURRENT  
THROUGH COIL

**100% SATISFACTION GUARANTEED**

**BUY IT NOW!**

**Click Here To Order**

## VACUUM SYMBOLS

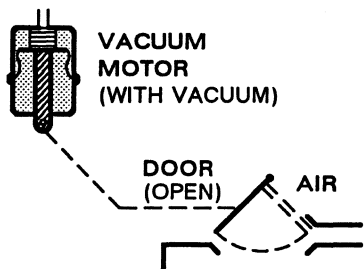
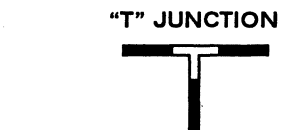

VACUUM ON VACUUM MOTOR PULLS DOOR OPEN TO LET AIR PASS THROUGH

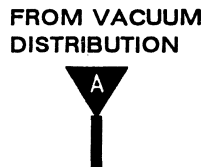
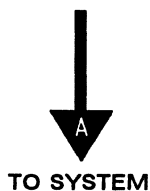

"CUT" HOSES REFERENCED BETWEEN PAGES  
ARROW SHOWS FROM MANIFOLD FITTING TO COMPONENT

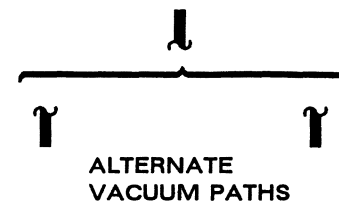

**NOTE**  
Other vacuum symbols used on vacuum system diagrams are fully explained on those pages.

## VACUUM MOTOR OPERATION

### SINGLE DIAPHRAGM MOTOR

NO VACUUM



VACUUM



### SERVO MOTOR



Some vacuum motors, such as the Servo Motor in the Speed Control, can position the actuating arm at any position between fully extended and fully retracted. The Servo is operated by a control valve that applies varying amounts of vacuum to the motor. The higher the vacuum level, the greater the retraction of the motor arm. Servo Motors work nearly the same way as two-position motors, except for the way the vacuum is applied. Servo Motors are generally larger and provide a calibrated control.

### DOUBLE DIAPHRAGM MOTOR

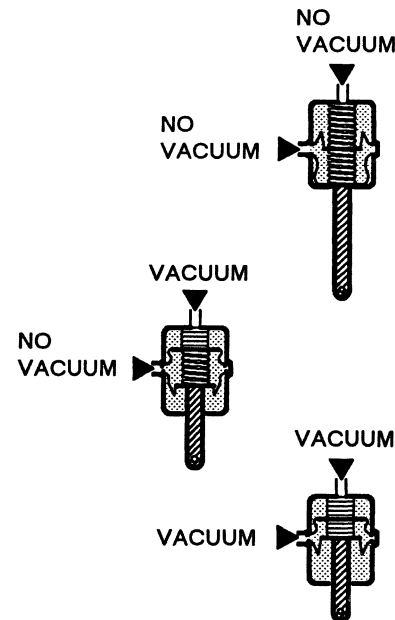

A double diaphragm motor has three positions (it is actually two motors in one housing). When the top port gets vacuum, the shaft pulls halfway in. When both ports get vacuum, the shaft pulls all the way in.

Vacuum motors operate like electrical solenoids, mechanically pushing or pulling a shaft all the way in or all the way out when vacuum is applied.

**100% SATISFACTION GUARANTEED**

**BUY IT NOW!**

**Click Here To Order**

# 7-1 TROUBLESHOOTING/DESCRIPTIONS

## SECTION 10

### GROUNDS

#### HOW THE CIRCUIT WORKS

The ground circuits show how many different systems may share a common ground point.

While all of the ground circuits are shown complete, additional ground circuits may exist in the vehicle. Any ground circuit not shown in cell 10 is shown complete in the appropriate system schematic.

All wires are 57 (BK) unless otherwise noted.

## SECTION 12

### CHARGING SYSTEM

#### HOW THE CIRCUIT WORKS

##### With Integral Regulator

The Alternator is belt-driven by the engine and generates power to keep the Battery fully charged and to operate electrical systems in the vehicle.

Alternator output is variable and depends on the speed at which the alternator rotor spins, as well as the amount of current passing through the rotor winding. Current flow through the rotor winding is controlled by a Regulator that is built into the Alternator.

The Alternator generates alternating current, which is passed through a series of rectifier diodes and converted to direct current.

##### Without Integral Regulator

The Battery, Alternator and Voltage Regulator make up the Charging System. With the Ignition Switch in RUN, battery voltage is applied through the solid-state electronic control of the Voltage Regulator. The electronic control applies battery voltage to the Alternator field.

With current in the field and the rotor turning, the Alternator stator produces a DC voltage at B+ terminals (to Battery). If the Alternator output voltage is greater than the Battery terminal voltage, current will flow from the Alternator to the Battery, as well as to the vehicle electrical load.

If the Alternator voltage is less than the battery terminal voltage, current will flow from the Battery to supplement the alternator output in supplying the vehicle electrical load.

##### Charge Indicator

With the Ignition Switch in START or RUN, battery voltage is present at the Charge Indicator.

If the Alternator is not generating power, the Regulator inside the Alternator grounds the Charge Indicator through circuit 904 (LG/R). The Charge Indicator illuminates.

When the Alternator is generating power, the Regulator inside the Alternator applies battery voltage to the Charge Indicator through circuit 904 (LG/R). With battery voltage present at both ends of the Charge Indicator, there is no current flow and the Charge Indicator does not illuminate.

#### TROUBLESHOOTING HINTS

CONDITION	POSSIBLE CAUSE	ACTION
Battery doesn't stay charged.	<ul style="list-style-type: none"><li>Open or poor connection at Alternator output.</li></ul>	<ul style="list-style-type: none"><li>Check that connectors or terminals on Alternator are clean and tight.</li><li>Check Fuse Link J.</li></ul>

**100% SATISFACTION GUARANTEED**

**BUY IT NOW!**

**Click Here To Order**

PayPal American Express Discover MasterCard VISA

## SECTION 12 (cont'd)

### TRUBLESHOOTING HINTS

CONDITION	POSSIBLE CAUSE	ACTION
<ul style="list-style-type: none"> <li>Charge Indicator is always on.</li> </ul>	<ul style="list-style-type: none"> <li>Loose alternator drive belt.</li> <li>Corroded battery terminals.</li> <li>Inoperative Voltage Regulator.</li> </ul>	<ul style="list-style-type: none"> <li>Check alternator drive belt tension.</li> <li>Check that battery post terminals are clean. Check that terminals on battery posts cannot be easily turned by hand.</li> <li>Refer to Section 31-01 of the Shop Manual for alternator testing procedures.</li> </ul>

For further diagnostic information, refer to Section 14-00 of the Shop Manual.

## SECTION 13

### POWER DISTRIBUTION HOW THE CIRCUIT WORKS

The Power Distribution circuits show how

several systems receive power through the same fuse, circuit breaker or fuse link cartridge.

The circuits shown also indicate whether a particular fuse, circuit breaker or fuse link cartridge receives power directly from the Battery or through the Ignition Switch contacts.

For further diagnostic information, refer to Section 18-01 of the Shop Manual.

## SECTION 20

### STARTING SYSTEM HOW THE CIRCUIT WORKS

#### Gasoline

Voltage is present at the Ignition Switch and Relay contacts at all times.

(and the  
ral Safety  
Sensor

closed), current flows through the Ignition Switch, the appropriate transmission switch (mentioned above) and the Starter Relay coil to ground. The Starter Relay coil is energized and its contacts close. Current now flows from the Battery directly through the Starter Relay contacts and Starter Motor to ground; the Motor runs to crank the engine.

The TFI Ignition Module also receives a start signal with the Ignition Switch in START (and

the appropriate transmission switch closed).

#### Diesel

The Starting System for the 7.3L diesel engine is similar to that of the gasoline engine.

With the Ignition Switch in START, voltage is applied to the Wait To Start Indicator, which is grounded by the Glow Plug Controller. See Section 26 for Glow Plug Control's circuit operation.

**100% SATISFACTION GUARANTEED**

**BUY IT NOW!**

**Click Here To Order**

Payment logos: PayPal, American Express, Discover, MasterCard, VISA

# 7-3 TROUBLESHOOTING/DESCRIPTIONS

## SECTION 20 (cont'd)

### TROUBLESHOOTING HINTS

CONDITION	POSSIBLE CAUSE	ACTION
<ul style="list-style-type: none"> <li>Starter Relay clicks, but starter doesn't crank.</li> </ul>	<ul style="list-style-type: none"> <li>Corroded terminals on Battery, Starter Relay or Starter Motor.</li> </ul>	<ul style="list-style-type: none"> <li>Check that terminals are clean at battery posts, Starter Relay, engine ground and Starter Motor. Check that cable terminals are tight and cannot be easily turned by hand.</li> <li>Disconnect 11 (T/Y) wire from Ignition Coil and measure voltage between negative battery terminal and ground while Ignition Switch is in START. If voltage is greater than 0.5 volts, check negative battery terminal and engine ground for corroded connections, or check cable to engine ground.</li> <li>Measure voltage between positive battery terminal and main (battery) terminal of Starter Relay while Ignition Switch is in START. If voltage is greater than 0.5 volts, check positive battery terminal and main relay terminal for corroded connections, or check red battery cable.</li> <li>Check that the ground terminals for the Starter Relay and Starter Motor are clean and tight.</li> </ul>
<ul style="list-style-type: none"> <li>Starter Relay doesn't click.</li> </ul>	<ul style="list-style-type: none"> <li>Inoperative Ignition Switch.</li> <li>Starter Relay not grounded.</li> </ul>	<ul style="list-style-type: none"> <li>Remove 32 (R/LB) wire from Starter Relay. With transmission in PARK or NEUTRAL, jumper this terminal to the main (battery) terminal of the Starter Relay. If starter operates, check Ignition Switch and Start Circuit.</li> <li>Check that Starter Relay bracket is grounded tightly. Repeat action mentioned above.</li> </ul>
<ul style="list-style-type: none"> <li>Starter spins (humming noise) but doesn't crank engine.</li> </ul>	<ul style="list-style-type: none"> <li>Inoperative starter drive.</li> </ul>	<ul style="list-style-type: none"> <li>Remove Starter Motor and check/repair starter drive.</li> </ul>
<ul style="list-style-type: none"> <li>Starter cranks slowly, or Starter Relay chatters.</li> </ul>	<ul style="list-style-type: none"> <li>Low charge in Battery.</li> </ul>	<ul style="list-style-type: none"> <li>Disconnect 11 (T/Y) wire from Ignition Coil to prevent engine from starting.</li> <li>Measure voltage at battery terminals while Ignition Switch is in START. If voltage is less than 9.5 volts, recharge Battery.</li> </ul>

For further diagnostic information, refer to Section 03-06 of the Shop Manual.

**100% SATISFACTION GUARANTEED**

**BUY IT NOW!**

**Click Here To Order**

### IGNITION SYSTEM

#### HOW THE CIRCUIT WORKS

The Distributor contains no centrifugal or vacuum advance mechanisms. All spark advance/retard is accomplished electronically by the Electronic Engine Control (EEC) Module.

During engine cranking (and after the engine starts), a Hall Effect Switch inside the Distributor assembly sends a variable voltage signal to the Thick Film Integrated (TFI) Ignition Module, which is mounted on the left fender wall.

The TFI Ignition Module passes this Profile Ignition Pickup (PIP) signal to the Electronic Engine Control (EEC) Module, which uses it to determine crankshaft position and engine speed. Using the signal and information provided by other engine control sensors, the EEC Module determines the appropriate ignition

timing. The EEC Module then sends a Spark Output (SPOUT) timing signal back to the TFI Ignition Module.

The TFI Ignition Module turns the Ignition Coil primary circuit on and off, according to the SPOUT signal from the EEC Module. Each interruption of the Ignition Coil primary circuit causes the Ignition Coil secondary circuit to produce an open circuit high voltage pulse of up to 40,000 volts. These high voltage pulses are routed to the Distributor, which sends them to the spark plugs.

The EEC Module monitors the TFI Ignition Module's control of the Ignition Coil through the Ignition Diagnostic Monitor (IDM) circuit.

If the TFI Ignition Module does not receive a SPOUT signal from the EEC Module, the Ignition Module will set timing at a fixed value.

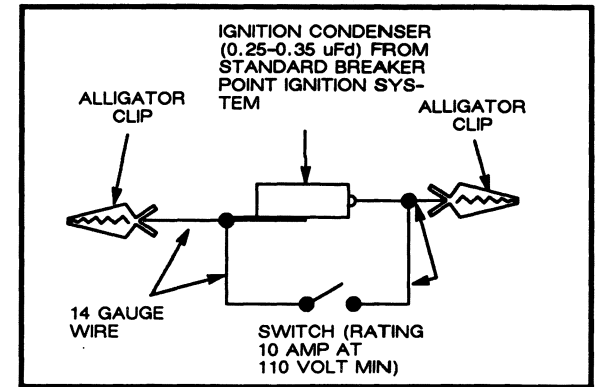

Figure 1

Make up a test jumper as shown in Figure 1. It is important to use only this test jumper when making these checks. Solid wire jumpers will not work for the quick checks.

#### CAUTION

Do not leave test jumper closed for more than one second at a time.

#### TROUBLESHOOTING HINTS

CONDITION	POSSIBLE CAUSE	ACTION
<ul style="list-style-type: none"> <li>Starter cranks engine, but engine doesn't start.</li> </ul>	<ul style="list-style-type: none"> <li>No voltage at TFI Ignition Module or Distributor.</li> <li>Inoperative TFI Ignition Module.</li> </ul>	<ul style="list-style-type: none"> <li>Check that TFI Ignition Module is securely attached to Distributor.</li> <li>Check for loose or damaged spark plug wires or coil wires. If any boots or nipples are removed, reapply new silicone dielectric compound.</li> <li>Make sure all ignition wires are connected correctly.</li> <li>VOLTAGE TEST Disconnect connector at TFI Ignition Module. Check for battery voltage between each pin (+) and ground (-) as follows (use a straight pin in connector socket hole to make contact):</li> </ul>

**100% SATISFACTION GUARANTEED**

**BUY IT NOW!**

**Click Here To Order**

# 7-5 TROUBLESHOOTING/DESCRIPTIONS

## SECTION 21 (cont'd)

### TROUBLESHOOTING HINTS

CONDITION	POSSIBLE CAUSE	ACTION
<ul style="list-style-type: none"> <li>Starter cranks engine, but engine doesn't start.</li> </ul>	<ul style="list-style-type: none"> <li>No voltage at TFI Ignition Module or Distributor.</li> <li>Inoperative TFI Ignition Module.</li> </ul>	<ol style="list-style-type: none"> <li>With Ignition Switch in OFF position, check for 0 volts at each terminal.               <ul style="list-style-type: none"> <li>If voltage is present, check Ignition Switch.</li> </ul> </li> <li>Turn Ignition Switch to RUN. Check for battery voltage at 16 (R/LG) wire. Check for 0 volts at 32 (R/LB) wire.               <ul style="list-style-type: none"> <li>If voltage is present, check Ignition Switch.</li> </ul> </li> <li>Disconnect 32 (R/LB) wire plug at Starter Relay. Turn Ignition Switch to START. Check for battery voltage at both above-mentioned wires.               <ul style="list-style-type: none"> <li>Check continuity of Ignition Switch and 32 (R/LB) wire if inoperative.</li> </ul> </li> <li>Reconnect 32 (R/LB) wire at Starter Relay.</li> </ol> <ul style="list-style-type: none"> <li><b>RUN-MODE SPARK TEST</b> <ol style="list-style-type: none"> <li>Remove coil wire from Distributor cap. Install spark tester in coil wire terminal.</li> <li>Unplug connector at TFI Ignition Module. In the harness side of the connector, connect the special test jumper (Figure 1) between ground and the 11 (T/Y) lead. Use a straight pin in connector socket hole to make contact.</li> <li>With the Ignition Switch in RUN, close the test jumper switch. Leave closed for about one second, then open. Repeat this several times. There should be a spark each time this switch is opened.                   <ul style="list-style-type: none"> <li>If there is no spark, the problem is in the primary circuit. Check coil for internal shorts or opens. Check primary resistance (0.5 ohm) and secondary resistance (8000 to 11,500 ohms).</li> <li>If the coil is good and there is no spark, check TFI Ignition Module.</li> </ul> </li> </ol> </li> </ul>



**BUY IT NOW!**

**Click Here To Order**



For further diagnostic information, refer to Section 23 of the Shop Manual and Section 13 of the Powertrain Control/Emissions Diagnosis Manual.

## SECTION 23

### ELECTRONIC ENGINE CONTROL (EFI) (4.9L)

#### HOW THE CIRCUIT WORKS

The Electronic Engine Control System includes an Electronic Engine Control (EEC) Module that receives inputs from various sensors, and uses the input information to control (1) Fuel Flow, (2) Exhaust Gas Recirculation (EGR), (3) Ignition and (4) Evaporative Emission. These four systems and the EEC Module work together to provide improved fuel economy and performance, and lower exhaust emissions.

#### EEC Power Relay

The EEC Power Relay supplies power to the EEC Module and EEC System-related components. When the Ignition Switch is turned to START or RUN, voltage is applied to the EEC Power Relay coil, and the Relay's contacts close.

Voltage is also applied through the EEC Power Relay contacts to the Fuel Pump Relay, Fuel injectors, the EEC Module, the EGR Valve, and the Thermax Air Solenoid. Idle Speed Control is also controlled by the EEC Module.

(EFI) engine intake

manifold at the intake port, to meter fuel into the engine.

The Fuel Injectors are divided into two groups of three. With each crankshaft revolution, one group of Fuel Injectors is energized. The next crankshaft revolution energizes the second group of Fuel Injectors.

The EEC Module controls the injectors' "on time" or pulse width. The EEC Module determines the appropriate injector pulse width and outputs a command to the injector to meter the exact quantity of fuel.

The electric Fuel Pump supplies fuel under pressure to the fuel rail and the Fuel Injectors. When the Ignition Switch is in START or RUN, voltage is applied from the EEC Power Relay to the Fuel Pump Relay coil. The coil is grounded by the EEC Module, the relay contacts close and voltage is applied to the electric Fuel Pump.

The Inertia Switch is a safety device that cuts voltage to the Electric Fuel Pump in the event of a collision. Once the Inertia Switch opens it must be reset manually.

#### Exhaust Gas Recirculation (EGR)

The EEC Module controls exhaust gas recirculation by varying the voltage applied to the

EGR Valve Position Sensor. This Valve, in turn, regulates the amount of vacuum applied to the EGR valve. The EGR Valve Position Sensor indicates valve position to the EEC Module by providing a voltage signal proportional to the EGR position, depending on engine operating conditions.

#### Thermactor Air System

The efficiency of the catalytic converter depends upon the temperature and chemical composition of the exhaust gases.

A Thermactor Air System, including a Thermactor Air Bypass (TAB) and Diverter Solenoid (TAD), controls the flow of secondary air to the exhaust manifold, catalytic converter, or to the atmosphere, depending on engine operating conditions.

When the Thermactor Air Bypass (TAB) Solenoid is OFF (deenergized), Thermactor Air is dumped into the atmosphere. When the Thermactor Air Bypass (TAB) Solenoid is (ON) energized, and the Thermactor Air Diverter (TAD) Solenoid is off (deenergized), Thermactor Air is routed to the catalytic converter. When the Thermactor Air Bypass (TAB) Solenoid and the Thermactor Air (TAD) Solenoid are both on (energized), Thermactor Air is routed to the exhaust manifold.

# 7-7 TROUBLESHOOTING/DESCRIPTIONS

## SECTION 23 (cont'd)

### Canister Purge Solenoid

The EEC Module controls the Canister Purge Solenoid. When the EEC Module grounds the Canister Purge Solenoid, fuel vapors collected by the carbon canister are released and burned by the engine.

### Idle Speed Control

The Idle Speed Control regulates engine idle speed by controlling the amount of air allowed to flow around the throttle plates.

### Knock Sensor

The Knock Sensor signals the EEC Module to retard timing if the engine knocks during operation.

### Engine Coolant Temperature Sensor

The Engine Coolant Temperature Sensor is a thermistor in which resistance decreases as engine coolant temperature increases. The EEC Module detects the voltage drop across the Engine Coolant Temperature (ECT) Sensor

and uses this information to help calculate fuel delivery, spark timing and EGR control.

### Throttle Position Sensor

The Throttle Position Sensor (TPS) is a potentiometer with a DC voltage output that varies with throttle plate angle. By monitoring the Throttle Position Sensor (TPS) output, the EEC Module calculates fuel delivery requirements based on driver demand.

### Air Charge Temperature Sensor

The Air Charge Temperature (ACT) Sensor is a thermistor in which resistance decreases as intake air temperature increases. The EEC Module detects the voltage drop across the Air Charge Temperature (ACT) Sensor and uses this information to help calculate fuel delivery, spark timing, and EGR control.

### Manifold Absolute Pressure (MAP) Sensor

The Manifold Absolute Pressure (MAP) Sensor measures the pressure in the intake manifold and provides this information as a

variable frequency signal to the EEC Module. With the Ignition Switch in the KEY ON/ENGINE OFF position, the MAP Sensor measures the barometric pressure in the intake manifold.

### EGR Valve Position Sensor

The EEC Module uses the EGR Position Sensor to check the position of the EGR Vacuum Regulator Solenoid. The EEC Module also uses the EGR Position Sensor to calculate the proper amount of EGR flow necessary to reduce NO<sub>2</sub> emissions. The EEC Module then determines the proper operating cycle for the EGR Vacuum Regulator Solenoid.

### Heated Exhaust Gas Oxygen (HEGO) Sensor

The Heated Exhaust Gas Oxygen (HEGO) Sensor provides to the EEC Module a voltage that regulates the air/fuel ratio by sensing the oxygen content of the exhaust gases. Too much oxygen indicates a lean mixture, while too little oxygen indicates a rich mixture.

For further diagnostic information, refer to the Powertrain Control/Emissions Diagnosis Manual.

## SECTION 24

### ELECTRONIC ENGINE CONTROL (EFI) (5.0L AND 5.8L)

THE CIRCUIT WORKS

**BUY IT NOW!**

Click Here To Order

System in-  
trol (EEC)

Module that receives inputs from various sensors. The EEC Module uses the input information to control (1) Fuel Flow, (2) Exhaust Gas Recirculation (EGR), (3) Ignition and (4) Evaporative Emissions. These four systems and the EEC Module work together to provide improved

fuel economy and performance, and lower exhaust emissions.



### EEC Power Relay

The EEC Power Relay supplies power to the EEC Module and EEC System-related components. When the Ignition Switch is turned to START or RUN, voltage is applied to the EEC Power Relay coil, and the Relay's contacts close.

Voltage is also applied through the EEC Power Relay contacts to the Fuel Pump Relay, the Fuel Injectors, the EEC Module, the EGR Solenoid and the Thermax Air Solenoids.

### Fuel Flow

The 5.0L and 5.8L Electronic Fuel Injection (EFI) Engine uses Fuel Injectors, mounted in the Intake Manifold at the Intake Port, to meter fuel into the engine.

The Fuel Injectors are divided into two groups of four. With each crankshaft revolution, one group of Fuel Injectors is energized. The next crankshaft revolution energizes the second group of Fuel Injectors.

The EEC Module controls the injectors' "on time" or pulse width. The EEC Module determines the appropriate injector pulse width and outputs a command to the injector to meter the exact quantity of fuel.

The electric Fuel Pump supplies fuel under pressure to the fuel rail and the Fuel Injectors. When the Ignition Switch is in START or RUN, voltage is applied from the EEC Power Relay to Fuel Pump Relay coil. The coil is grounded to the EEC Module, the Relay's contacts close

and voltage is applied to the electric Fuel Pump.

The Inertia Switch is a safety device that cuts voltage to the electric Fuel Pump in the event of a collision. Once the Inertia Switch opens it must be reset manually.

### Exhaust Gas Recirculation (EGR)

The EEC Module controls exhaust gas recirculation by varying the voltage applied to the EGR Valve Position Sensor. This Valve, in turn, regulates the amount of vacuum applied to the EGR Valve. The EGR Valve Position Sensor indicates Valve position to the EEC Module by providing a voltage signal proportional to the EGR position, depending on engine operating conditions.

### Thermax Air System

The efficiency of the Catalytic Converter depends upon the temperature and chemical composition of exhaust gases.

A Thermax Air System, including a Thermax Air Bypass (TAB) and Diverter Solenoid (TAD), controls the flow of secondary air to the Exhaust Manifold, Catalytic Converter, or the atmosphere, depending on engine operating conditions.

When the Thermax Air Bypass (TAB) Solenoid is off (deenergized), Thermax Air is dumped into the atmosphere. When the Thermax Air Bypass (TAB) Solenoid is on (energized) and the Thermax Air Diverter (TAD) Solenoid is off (deenergized), Thermax Air is routed to the Catalytic Converter. When the

Thermax Air Bypass (TAB) Solenoid and the Thermax Air Diverter (TAD) Solenoid are both on (energized), Thermax Air is routed to the Exhaust Manifold.

### Canister Purge Solenoid

The EEC Module controls the Canister Solenoid. When the EEC Module grounds the Canister Purge Solenoid, fuel vapors collected by the carbon canister are released and burned by the engine.

### Idle Air Bypass Valve

The Idle Air Bypass Valve regulates engine idle speed by controlling the amount of air allowed to flow around the throttle plates.

### Knock Sensor (5.0L Only)

The Knock Sensor signals the EEC Module to retard timing if the engine knocks during operation.

### Power Steering Pressure Switch (5.0L Without E4OD Only)

The Power Steering Pressure Switch signals the EEC Module when power steering pressure exceeds 350 psi +50. The engine then increases idle speed to compensate for the additional load.

### Throttle Position Sensor

The Throttle Position Sensor (TPS) is a potentiometer with a DC voltage output that varies with throttle plate angle. By monitoring the Throttle Position Sensor (TPS) output, the EEC Module calculates fuel delivery requirements based on driver demand.



# 7-9 TROUBLESHOOTING/DESCRIPTIONS

## SECTION 24 (cont'd)

### EGR Valve Position Sensor

The EEC Module uses the EGR Position Sensor to check the position of the EGR Vacuum Regulator Solenoid. The EEC Module also uses the EGR Position Sensor to calculate the proper amount of EGR flow necessary to reduce NO<sub>2</sub> emissions. The EEC Module then determines the proper operating cycle for the EGR Vacuum Regulator Solenoid.

### Manifold Absolute Pressure (MAP) Sensor

The Manifold Absolute Pressure (MAP) Sensor measures the pressure in the intake manifold and provides this information as a variable frequency signal to the EEC Module. With the Ignition Switch in the KEY ON/ENGINE

OFF position, the MAP Sensor measures the barometric pressure in the intake manifold.

### Engine Coolant Temperature Sensor

The Engine Coolant Temperature (ECT) Sensor is a thermistor in which resistance decreases as engine coolant temperature increases. The EEC Module detects the voltage drop across the Engine Coolant Temperature (ECT) Sensor and uses this information to help calculate fuel delivery, spark timing and EGR control.

### Air Charge Temperature Sensor

The Air Charge Temperature (ACT) Sensor is a thermistor in which resistance decreases

as intake air temperature increases. The EEC Module detects the voltage drop across the Air Charge Temperature (ACT) Sensor and uses this information to help calculate fuel delivery, spark timing and EGR control.

### Heated Exhaust Gas Oxygen (HEGO) Sensor

The Heated Exhaust Gas Oxygen (HEGO) Sensor provides to the EEC Module a voltage that regulates the air fuel ratio by sensing the oxygen content of the exhaust gases. Too much oxygen indicates a lean mixture, while too little oxygen indicates a rich mixture.

For further diagnostic information, refer to the Powertrain Control/Emissions Diagnosis Manual.

## SECTION 25

### ELECTRONIC ENGINE CONTROL (7.5L)

#### HOW THE CIRCUIT WORKS

The Electronic Engine Control System includes an Electronic Engine Control (EEC) Module that receives inputs from various sensors. The EEC Module uses the input information to control (1) Fuel Flow, (2) Exhaust Gas Regulation (EGR), (3) Ignition and (4) Evaporative Emissions. These four systems and the improved lower ex-

#### EEC Power Relay

The EEC Power Relay supplies power to the EEC Module and EEC System-related components. When the Ignition Switch is turned to START or RUN, voltage is applied to the EEC Power Relay coil, and the Relay's contacts close.

Voltage is applied through the EEC Power Relay contacts to the Fuel Pump Relay, the Fuel Injectors, the EEC Module, the EGR Solenoid and the Thermactor Solenoids.

#### Fuel Flow

The 7.5L Electronic Fuel Injection (EFI) en-

gine uses Fuel Injectors, mounted in the intake manifold at the intake port, to meter fuel into the engine.

The Fuel Injectors are divided into two groups of four. With each crankshaft revolution, one group of Fuel Injectors is energized. The next crankshaft revolution energizes the second group of Fuel injectors.

The EEC Module controls the injectors' "on time" or pulse width. The EEC Module determines the appropriate injector pulse width and outputs a command to the injector to meter the exact quantity of fuel.

**100% SATISFACTION GUARANTEED**

**BUY IT NOW!**

**Click Here To Order**

PayPal American Express Discover MasterCard VISA

The electric Fuel Pump supplies fuel under pressure to the fuel rail and the Fuel Injectors. When the Ignition Switch is in START or RUN, voltage is applied from the EEC Power Relay to the Fuel Pump Relay coil. The coil is grounded by the EEC Module, the Relay's contacts close, and voltage is applied to the electric Fuel Pump.

The Inertia Switch is a safety device that cuts voltage to the Electric Fuel Pump in the event of a collision. Once the Inertia Switch opens it must be reset manually.

### Exhaust Gas Recirculation (EGR)

The EEC Module controls exhaust gas recirculation by varying the voltage applied to the EGR Valve Position Sensor. This Valve, in turn, regulates the amount of vacuum applied to the EGR Valve. The EGR Valve Position Sensor indicates Valve position to the EEC Module by providing a voltage signal proportional to the EGR position, depending on engine operating conditions.

### Canister Purge Solenoid

The EEC Module controls the Canister Purge Solenoid. When the EEC Module grounds the Canister Purge Solenoid, fuel vapors collected by the carbon canister are released and burned by the engine.

### Idle Air Bypass Valve

The Idle Air Bypass Valve controls engine speed by regulating the amount of air allowed to pass around the throttle plates. This valve is used to maintain engine speed at idle speed.

corrections to prevent engine stall during cold engine warm-ups. As engine load changes, the diode provides voltage spike suppression.

### Thermactor Air Bypass Solenoid

A Thermactor Air System supplies secondary air to the exhaust manifold(s), to the catalytic converter or to the atmosphere, depending on engine conditions sensed by the EEC Module through the system inputs.

When the Thermactor Air Bypass (TAB) Solenoid is off (deenergized), Thermactor Air is dumped into the atmosphere rather than routed to the catalytic converter or exhaust manifold.

When the Thermactor Air Bypass (TAB) Solenoid is on (energized), the Thermactor Air is routed to the catalytic converter.

### Ignition System

The EEC System has a special Distributor and Ignition Module. The EEC Distributor has no vacuum advance mechanism. Instead, all ignition timing is controlled by the EEC Module.

The EEC Module receives engine timing information from the Distributor through the TFI Ignition Module. The EEC Module uses this information to determine spark timing and advance.

### Electronic Control Assembly Inputs

The EEC Module uses information from various sensors to determine engine operating conditions.

### Air Charge Temperature Sensor

The Air Charge Temperature (ACT) Sensor is a thermistor in which resistance decreases as intake air temperature increases. The EEC Module detects the voltage drop across the Air Charge Temperature (ACT) Sensor and uses this information to help calculate fuel delivery, spark timing, and EGR control.

### Throttle Position Sensor

The Throttle Position Sensor is a potentiometer with a DC voltage output that varies with throttle plate angle. By monitoring the Throttle Position Sensor (TPS) output, the EEC Module calculates fuel delivery requirements based on driver demand.

### Engine Coolant Temperature Sensor

The Engine Coolant Temperature (ECT) Sensor is a thermistor in which resistance decreases as engine coolant temperature decreases. The EEC Module detects the voltage drop across the Engine Coolant Temperature (ECT) Sensor and uses this information to help calculate fuel delivery, spark timing and EGR control.

### Manifold Absolute Pressure (MAP) Sensor

The Manifold Absolute Pressure (MAP) Sensor measures the pressure in the intake manifold and provides this information as a variable frequency signal to the EEC Module. With the Ignition Switch in the KEY ON/ENGINE OFF position, the MAP Sensor measures the barometric pressure in the intake manifold.



# 7-11 TROUBLESHOOTING/DESCRIPTIONS

## SECTION 25 (cont'd)

### Heated Exhaust Gas Oxygen (HEGO) Sensor

The Heated Exhaust Gas Oxygen (HEGO) Sensor provides to the EEC Module a voltage

that regulates the air/fuel ratio by sensing the oxygen content of the exhaust gases. Too much oxygen indicates a lean mixture, while too little oxygen indicates a rich mixture.

For further diagnostic information, refer to the Powertrain Control/Emissions Diagnosis Manual.

## SECTION 26

### GLOW PLUG CONTROL

#### HOW THE CIRCUIT WORKS

The Glow Plug Control circuit applies power to the Glow Plugs, which heat the combustion chambers so that the diesel engine can be started.

#### Glow Plug Controller

The solid-state Glow Plug Controller, attached to the top of the engine block, controls the glow plug pre-glow and after-glow time. It also controls the circuit's operation by sensing engine temperature, glow plug voltage and after-glow voltage from the start/run circuit.

When the Ignition Switch is turned to RUN, voltage from Maxi-fuse K is applied through the Glow Plug Controller to the Wait-To-Start Indicator Lamp.

The Glow Plugs heat up in zero to fifteen seconds, depending on engine coolant tempera-

ture. After the Glow Plugs heat up, the controller cycling switch opens and turns the Wait-To-Start Indicator Lamp off. The Glow Plugs are now warm enough for the engine to be started.

At the same time the Ignition Switch is turned to RUN, voltage from Maxi-fuse K is applied to the after-glow timer (located inside the Glow Plug Controller). The after-glow timer cycles the Glow Plugs for up to two minutes, depending on engine temperature. The after-glow timer then opens. The Wait-To-Start Indicator Lamp will not light during the after-glow period.

If the Ignition Switch is turned OFF, it can be turned to ON immediately, and the Glow Plug heating cycle will start again.

#### Diesel Start/Run

The diesel engine uses two batteries to provide extra power for starting and glow plug

heating. Power is applied from the batteries, through heavy gauge wires, to the Starter Solenoid (located in the Starter Motor assembly). When the Wait-To-Start Indicator goes out, the Ignition Switch can be turned to START.

With the Ignition Switch in START or RUN, voltage is supplied to the Fuel Heater, Fuel Shutoff Solenoid, and the Engine Temperature Switch through Maxi-fuses K and U.

The Fuel Heater is in the Fuel Filter/Separator. It heats the diesel fuel, melting any wax that might clog the filter. The heater has an internal thermostat to turn it on as needed.

The Fuel Shutoff Solenoid controls the flow of fuel into the injection pump. With the Ignition Switch in START or RUN, the Solenoid is energized, and fuel is allowed to flow into the injection pump. When the Ignition Switch is turned off, the solenoid is deenergized, fuel flow stops, and the engine stops running.

**100% SATISFACTION GUARANTEED**

**BUY IT NOW!**

**Click Here To Order**

PayPal American Express Discover MasterCard VISA

## SECTION 26 (cont'd)

The Engine Temperature Switch provides voltage to the Cold Timing Advance Solenoid and the Cold Idle Solenoid. When the engine temperature is below 112°F (44°C), the Engine Temperature Switch is closed. When the

Ignition Switch is turned to START or RUN, the solenoids are energized, advancing injection pump timing and engine idle, allowing the engine to run more smoothly when cold. When

the engine temperature reaches 112°F (44°C), the Engine Temperature Switch opens. This deenergizes the solenoids, returning the timing and idle to normal.

### TROUBLESHOOTING HINTS

CONDITION	POSSIBLE CAUSE	ACTION
<ul style="list-style-type: none"> <li>No Glow Plugs operate.</li> </ul>	<ul style="list-style-type: none"> <li>No voltage at Glow Plug Controller.</li> </ul>	<ul style="list-style-type: none"> <li>Check Maxi-fuse K and Fuse Links C and D.</li> <li>Check 16 (R/LG) and 37 (Y) wires for open.</li> </ul>
<ul style="list-style-type: none"> <li>One Glow Plug doesn't operate.</li> </ul>	<ul style="list-style-type: none"> <li>No voltage at BR wire of Glow Plug.</li> </ul>	<ul style="list-style-type: none"> <li>Check for open in BR wire.</li> </ul>

For further diagnostic information, refer to the Powertrain Control/Emissions Diagnosis Manual.

## SECTION 29

### E4OD TRANSMISSION CONTROL (DIESEL)

#### HOW THE CIRCUIT WORKS

The Transmission Electronic Control System includes a Transmission Electronic Control Assembly (TECA). The TECA receives various inputs from sensors. The TECA uses data supplied by these sensors to control: (1) transmission capacity, (2) up and down shift scheduling, (3) the Converter Clutch Solenoid, and (4) the Coast Clutch Control. The TECA and the Fuel Injection Pump Lever (FIPL) Sensor work together to provide a DC output proportional to the throttle plate angle. The TECA uses the FIPL Sensor's output to control shifting and converter engagement based on driver demand.

#### TECA Power Relay

When the TECA Power Relay is energized (Ignition Switch turned to START or RUN), the TECA and TECA-related components receive power.

#### Manual Lever Position Sensor

The Manual Lever Position Sensor provides the TECA with an input signal that indicates the position of the manual lever and gear selector.

#### Fuel Injection Pump Lever (FIPL) Sensor

The Fuel Injection Pump Lever (FIPL) Sensor is a potentiometer that provides a DC out-

put voltage proportional to the throttle plate angle. The TECA uses the FIPL Sensor's output to control shifting and converter engagement based on driver demand.

#### Overdrive Cancel Switch

The Overdrive Cancel Switch supplies an input signal to the TECA when an E4OD overdrive cancel request has been made.

#### 4x4 Indicator Switch

The 4x4 Hi/Low Indicator Switch informs the TECA Module of a 4x4/Low selection.

**100% SATISFACTION GUARANTEED**

**BUY IT NOW!**

**Click Here To Order**

PayPal American Express Discover MasterCard VISA

# 7-13 TROUBLESHOOTING/DESCRIPTIONS

## SECTION 29 (cont'd)

For further diagnostic information, refer to the Powertrain Control/Emissions Diagnosis Manual.

## SECTION 30

### E4OD TRANSMISSION (GASOLINE)

#### HOW THE CIRCUIT WORKS

The E4OD Transmission is an electronically controlled automatic transmission. The EEC

Module uses inputs from various sensors to control the operation of the E4OD Transmission. The Overdrive Cancel Switch disables the overdrive operation and enables automatic operation through the first three gears.

For further diagnostic information, refer to the Powertrain Control/Emissions Diagnosis Manual.

## SECTION 31

### SPEED CONTROL

#### HOW THE CIRCUIT WORKS

The Speed Control Amplifier controls vacuum to the Speed Control Servo Motor through the Modulating Valve. The Servo Motor moves the throttle through the Actuator cable.

To operate the Speed Control System, the engine must be running and vehicle speed must be greater than 30 mph. The System is turned on by pressing the Speed Control Switch ON.

Vehicle's current speed the set speed. The Programmable Speedometer/Odometer Module (located in the Instrument Cluster) sends a speed signal to the input of the Speed Control Amplifier through the 679 (GY/BK) wire. This signal tells the Amplifier to increase or decrease the vacuum at the Servo Motor to keep the vehicle at the set speed.

Pressing and holding SET/ACCEL increases the vehicle's speed as long as SET/ACCEL is depressed. Releasing SET/ACCEL gives the System a new set speed to maintain. Vehicle speed may also be increased by depressing the accelerator until the higher speed is reached, then depressing and releasing SET/ACCEL.

Pressing and holding COAST decreases the vehicle's speed as long as COAST is depressed. Releasing COAST gives the system a new set speed to maintain.

Pressing OFF turns off the System (grounds LB/BK wire). The System is also turned off when the brake pedal is depressed or the Ignition Switch is turned OFF. The Vacuum Dump Valve also operates when the brake pedal is depressed. This is a backup device that releases the servo. In vehicles with manual transaxle, the Clutch Switch opens when the clutch pedal is depressed and turns off the System.

ACCEL or  
Speed Con-  
s the ve-



BUY IT NOW!  
Click Here To Order

PayPal American Express Discover MasterCard VISA

# TROUBLESHOOTING/DESCRIPTIONS 7-14

## SECTION 31 (cont'd)

When the System has been deactivated by depressing the brake or clutch pedal, the last

set speed may be resumed by pressing RESUME. This feature will not work if OFF has

been depressed or with car speed below 30 mph.

### TROUBLESHOOTING HINTS

CONDITION	POSSIBLE CAUSE	ACTION
<ul style="list-style-type: none"> <li>System doesn't operate.</li> </ul>	<ul style="list-style-type: none"> <li>Open circuit to Speed Control Switch.</li> <li>Open Modulating Valve.</li> </ul>	<ul style="list-style-type: none"> <li>Disconnect Speed Control Amplifier connector and measure the resistance between the 151 (LB/BK) wire and ground while pressing the switches indicated. Rotate steering wheel through its full range and check that resistance remains within the range given. Depress OFF: less than 1 ohm Depress SET/ACCEL: 646 to 714 ohms Depress COAST: 114 to 126 ohms Depress RESUME: 2090 to 2310 ohms</li> <li>If resistance fluctuates while steering wheel is rotated, remove steering wheel and clean slip rings (see Section 37 of the Shop Manual). If resistances are out of ranges shown, refer to Section 37 of the Shop Manual.</li> <li>Disconnect Speed Control Amplifier connector C217 and measure the resistance between the following wires: 144 (O/Y) and 145 (GY/BK): 40 to 75 ohms 144 (O/Y) and 146 (W/PK): 100 to 150 ohms</li> <li>If resistances aren't in the ranges shown, check the Modulating Valve.</li> </ul>
<ul style="list-style-type: none"> <li>System operates but is erratic or unstable.</li> </ul>	<ul style="list-style-type: none"> <li>Throttle linkage is binding or loose.</li> </ul>	<ul style="list-style-type: none"> <li>Check that Speed Control Servo and throttle linkage are not binding.</li> <li>Check that Actuator cable has as much tension as possible without holding throttle open.</li> </ul>



**BUY IT NOW!**  
Click Here To Order







# 7-15 TROUBLESHOOTING/DESCRIPTIONS

## SECTION 31 (cont'd)

For further diagnostic information, refer to Section 10-03 of the Shop Manual.

## SECTION 34

### ELECTRONIC SHIFT CONTROL HOW THE CIRCUIT WORKS

The Electronic Shift Control Module is powered at all times through Circuit Breaker 12 of the Fuse Panel to retain its memory capability. Fuse 18 provides power for the switches and the Electric Shift Motor when the Ignition Switch

is in RUN. Fuse 10 provides power for night-time illumination of the Electronic Shift Control Switch.

When the Electronic Shift Control Switch is placed in the 4x4 or LO position, the Electronic Shift Control Module analyzes information from the Shift Position Sensors to determine their

current positions. The Module also analyzes information inputs from the Transfer Case Speed Sensor and the Automatic Transmission Switch. The Electronic Shift Control Module then activates the Transfer Case Motor to produce the desired shift, and the 4x4 Indicator lights up.

### TROUBLESHOOTING HINTS

CONDITION	POSSIBLE CAUSE	ACTION
<ul style="list-style-type: none"><li>● Electronic Shift doesn't operate.</li></ul>	<ul style="list-style-type: none"><li>● No voltage at 517 (BK/W) or 296 (W/P) wires of Electronic Shift Module.</li><li>● Inoperative Electronic Shift Control Switch.</li><li>● Inoperative Transfer Case Shift Motor.</li><li>● Inoperative Electronic Shift Control Module.</li></ul>	<ul style="list-style-type: none"><li>● Check Circuit Breaker 12, Fuse 18 and 517 (BK/W) and 296 (W/P) circuits for an open.</li><li>● Check Switch.</li><li>● Check Motor.</li><li>● Self-Diagnostic Test<ol style="list-style-type: none"><li>a. Remove connectors C221 and C223 from the Electronic Shift Control Module.</li><li>b. Turn the Ignition Switch to RUN.</li><li>c. Activate the self-test switch and note the result: A flashing indicator lamp (approximately one flash per second for a total of 4 flashes) indicates that the Control Module is functioning properly. A steady indicator light indicates that the Control Module is inoperative and must be checked.</li></ol></li></ul>

**100% SATISFACTION GUARANTEED**

**BUY IT NOW!**

**Click Here To Order**

PayPal American Express Discover MasterCard VISA

For further diagnostic information, refer to Section 07-07A of the Shop Manual.

## SECTION 42

### ANTI-LOCK BRAKES

#### HOW THE CIRCUIT WORKS

##### Operation

The Rear Anti-lock Brake System (RABS) continuously monitors rear wheel speed with a sensor mounted on the rear axle. When the teeth on an excitor ring (mounted on the ring gear) pass the sensor pole piece, an AC voltage with a frequency proportional to the average rear wheel speed is induced in the sensor circuit. If an impending lockup condition occurs during braking, the RABS modulates hydraulic pressure to the rear brakes to inhibit rear wheel lockup.

When the brake pedal is applied, the RABS Module senses the drop in rear wheel speed. If the rate of deceleration is too great (indicating an impending rear wheel lockup) the RABS Module activates the RABS Valve Assembly Isolation Solenoid, causing the isolation valve to close. With the isolation valve closed, the

rear wheel cylinders are isolated from the master cylinder and the rear brake pressure cannot increase. If the rate of deceleration is still too great, the RABS Module will energize the dump solenoid with a series of rapid pulses to bleed off rear wheel cylinder fluid into an accumulator built into the RABS valve. This reduces the rear wheel cylinder pressure and allows the rear wheels to spin back up to vehicle speed.

When the driver releases the brake pedal at the end of a stop, the isolation valve deenergizes, and any fluid in the accumulator is returned to the master cylinder. Normal brake operation then resumes.

##### System Self-Test

The Rear Anti-lock Brake System has self-test capabilities similar to those in other electronic control systems. Two warning lamps, located in the instrument panel, alert the driver to a System malfunction. The red Brake Warning Lamp indicates a low fluid level or that the

parking brake is on. The yellow Anti-lock Brake Indicator lights up for approximately two seconds when the Ignition Switch is first moved to ON or START for circuit prove out. The Indicator also lights up when the RABS Module detects a malfunction in the System.

The self-test feature contains thirteen codes that indicate the area of the malfunction. When a malfunction is detected, the RABS Control Module shuts down the System and the yellow Anti-lock Warning Lamp comes on. This permits normal braking. A code that can be retrieved by momentarily grounding the diagnostic pigtail and counting the flashes of the yellow light is then set in the system memory. If the key is turned off before the diagnostic test is performed, the code will be lost, and the light will remain out until another malfunction is detected. If more than one fault exists, only the first code recorded will be displayed. Additional codes will be output only after the first fault is corrected.

For further diagnostic information, refer to Section 06-09 of the Shop Manual.

**100% SATISFACTION GUARANTEED**

**BUY IT NOW!**

**Click Here To Order**

PayPal American Express Discover Novus MasterCard VISA

# 7-17 TROUBLESHOOTING/DESCRIPTIONS

## SECTION 44

### HORN/CIGAR LIGHTER HOW THE CIRCUIT WORKS

#### Horn

When the Horn Switch on the steering wheel is depressed, the Horn Relay coil is grounded,

allowing the Relay to energize. Current flows from Fuse C, in the Engine Compartment Fuse Box, through the Horn Relay to the Low Pitch and High Pitch Horns.

#### Instrument Panel Cigar Lighter

Voltage is applied at all times through Fuse 9 to the Cigar Lighter. When the Cigar Lighter is depressed, the contacts close and current flows through the heating element to ground.

### TROUBLESHOOTING HINTS

CONDITION	POSSIBLE CAUSE	ACTION
<ul style="list-style-type: none"> <li>Horn doesn't work.</li> </ul>	<ul style="list-style-type: none"> <li>No voltage at Horn Relay.</li> </ul>	<ul style="list-style-type: none"> <li>Check Fuse C and 640 (Y/LB) wire for an open.</li> <li>Check Fuse 9.</li> <li>Remove Fuse C and connect meter across Fuse C position. If meter reads battery voltage when Horn Switch is pushed, the Switch is good.</li> <li>Attach a jumper between the Battery and Horn connector and another jumper between the Horn bracket and ground. (Do this step for both Left and Right Horns.) If Horn does not sound, turn adjusting screw <math>\frac{1}{4}</math> to <math>\frac{3}{8}</math> turn, then secure. If Horn does not sound, check Horn.</li> <li>Check for voltage at the Horn Relay connector 640 (Y/LB) wire.</li> <li>Ground Horn Relay 1 (DB) wire. If Horn doesn't sound, check Relay.</li> </ul>
<ul style="list-style-type: none"> <li>Horn doesn't turn off.</li> </ul>	<ul style="list-style-type: none"> <li>Short in circuit.</li> </ul>	<ul style="list-style-type: none"> <li>Disconnect connector C219 from Horn Switch. If Horn shuts off, check Horn Switch. If Horn continues to sound, check 1 (DB) wire for a short to ground. If ground is OK, check Horn Relay.</li> </ul>
<ul style="list-style-type: none"> <li>Cigar Lighter doesn't work.</li> </ul>	<ul style="list-style-type: none"> <li>No voltage at lighter.</li> </ul>	<ul style="list-style-type: none"> <li>Check Fuse 9.</li> <li>Check for voltage at the Cigar Lighter 40 (LB/W) circuit.</li> <li>Check for continuity to ground at the lighter shell.</li> </ul>

**100% SATISFACTION GUARANTEED**

**BUY IT NOW!**

Click Here To Order

For further diagnostic information, refer to Sections 13-06, 13-07 and 18-04 of the Shop Manual.

## SECTION 49

### FUEL TANK SELECTOR

#### HOW THE CIRCUIT WORKS

##### Diesel Engine

Voltage from Fuse 6 is supplied to the Fuel Tank Selector Switch when the Ignition Switch is in START or RUN. The position of the Fuel Tank Selector Switch determines the direction in which the Fuel Tank Selector Valve Motor will move. This determines which Fuel Tank Sender will control the Fuel Gauge position. Vehicles with diesel engines use mechanical fuel pumps.

##### Gasoline Engine

Voltage is supplied to the Fuel Tank Selector Switch whenever the Fuel Pump relay is energized (contacts closed).

When the Fuel Tank Selector Switch is placed in the FRONT position, power is supplied from the 786 (R) terminal of the Switch to the Front Tank Fuel Pump Motor. Fuel is pumped from the front tank. The signal from the Front Tank Fuel Gauge Sender is carried through the 673 (DB/Y) wire to the Fuel Tank

Selector Switch, and then through the 29 (Y/W) wire to the Fuel Gauge in the Instrument Cluster.

When the Fuel Tank Selector Switch is in the REAR position, power is supplied to the Rear Tank Fuel Pump Motor through the 789 (BR/W) wire from the Fuel Tank Selector Switch. The Rear Tank Fuel Gauge Sender signal is transmitted to the Switch through the 675 (Y/LB) wire, and then to the Instrument Cluster through the 29 (Y/W) wire.

#### TROUBLESHOOTING HINTS - DIESEL ENGINE

CONDITION	POSSIBLE CAUSE	ACTION
<ul style="list-style-type: none"> <li>Fuel Tank Selector Valve will not change position.</li> </ul>	<ul style="list-style-type: none"> <li>Inoperative Fuel Tank Selector Valve.</li> <li>Inoperative Fuel Tank Selector Switch.</li> <li>No power or ground to Fuel Tank Selector Switch.</li> </ul>	<ul style="list-style-type: none"> <li>With Fuel Tank Selector Switch in FRONT, check for battery voltage between 786 (R) (+) and 789 (BR/W) (-) terminals of Fuel Tank Selector Valve.</li> <li>With Fuel Tank Selector Switch in REAR, check for battery voltage between 786 (R) (-) and 789 (BR/W) (+) terminals of the Fuel Tank Selector Valve.</li> <li>If both voltages are correct, check Fuel Tank Selector Valve.</li> <li>If any voltage is not correct, check for battery voltage between 973 (R) (+) and 57 (BK) (-) terminals of Fuel Tank Selector Switch and verify continuity of 789 (BR/W) and 786 (R) wires before checking Fuel Tank Selector Switch.</li> </ul>



**BUY IT NOW!**

Click Here To Order 







# 7-19 TROUBLESHOOTING/DESCRIPTIONS

## SECTION 49 (cont'd)

### TROUBLESHOOTING HINTS - GASOLINE ENGINE

CONDITION	POSSIBLE CAUSE	ACTION
<ul style="list-style-type: none"><li>Both Fuel Pumps inoperative.</li></ul>	<ul style="list-style-type: none"><li>No power to Fuel Pumps.</li><li>Poor or no ground.</li></ul>	<ul style="list-style-type: none"><li>Check 238 and 298 (DG/Y) wires to Inertia Switch for open.</li><li>Check Inertia Switch for open.</li><li>Check 57 (BK) ground wires for open.</li></ul>
<ul style="list-style-type: none"><li>Front or Rear Fuel Pump inoperative.</li></ul>	<ul style="list-style-type: none"><li>Inoperative Fuel Tank Selector Switch.</li><li>Inoperative Fuel Pump.</li></ul>	<ul style="list-style-type: none"><li>With the Fuel Tank Selector Switch in FRONT position, check for continuity between 670 (R/Y) and 786 (R) terminals of the Switch.</li><li>With the Fuel Tank Selector Switch in REAR, check for continuity between 670 (R/Y) and 789 (BR/W) terminals of the Switch.</li><li>Check for an open in wires from Fuel Tank Selector Switch to suspect pump motor.</li></ul>

For further diagnostic information, refer to Section 10-01 of the Shop Manual.

## SECTION 53

### HEATER

#### HOW THE CIRCUIT WORKS

With the Ignition Switch in RUN and the Heater Control Assembly in any position except OFF, voltage is applied to the Blower Motor. With the Blower Motor Switch in LO, current flows through the Blower Motor and three resistors. In MED-LO, current flows through two resistors. In MED-HI, current flows through one resistor. In HI, current does not flow through a resistor. With the A/C-Heater Function Selector Switch in OFF, the Blower Motor does not

#### Lever Position and Operation

OFF - Vacuum is applied to the Outside-Recirculate Door Vacuum Motor, closing that door to outside air. The Panel Door closes the instrument panel outlets. The Floor-Defrost Door opens the floor outlets. The Blower does not operate and air does not pass through the system.

VENT - Outside air comes through the Outside-Recirculate Air Door. The Panel Door sends air to the instrument panel outlets (vacuum on motor). The Temperature Blend Door controls the air through the Heater Core.

FLOOR - Outside air controlled by the Temperature Control Lever passes through or around the Heater Core. The Panel Door closes and air is sent to the floor outlets (vacuum at ports A and B of the Floor-Defrost Door Vacuum Motor).

FLR/DEF - The Outside-Recirculate Air Door lets in outside air (no vacuum at motor). Vacuum is applied to port A of the Floor-Defrost Door. The door moves to mid-position and air is split between the floor and defrost outlets. The Panel Door closes.

DEFROST - With no vacuum at any Vacuum Motor, air passes through the outlets.

**100% SATISFACTION GUARANTEED**

**BUY IT NOW!**

**Click Here To Order**

PayPal, American Express, Discover, MasterCard, VISA

### TROUBLESHOOTING HINTS

CONDITION	POSSIBLE CAUSE	ACTION
<ul style="list-style-type: none"> <li>● Blower doesn't work.</li> </ul>	<ul style="list-style-type: none"> <li>● No voltage at Blower Motor.</li> <li>● Inoperative Blower Motor.</li> </ul>	<ul style="list-style-type: none"> <li>● Check Fuse 1 and the 399 (BR/Y) wire.</li> <li>● Set Blower Motor Switch to HI, Ignition Switch to RUN and Function Selector Switch to any position except OFF. Disconnect the Blower Motor connector and check for battery voltage between the 181 (BR/O) and 261 (O/BK) wires. If voltage is present, check Blower Motor.</li> </ul>
<ul style="list-style-type: none"> <li>● Blower doesn't run in LO speed setting, but runs in HI.</li> </ul>	<ul style="list-style-type: none"> <li>● Open Blower Motor Resistor or inoperative Blower Switch.</li> <li>● Open 57 (BK) or 261 (O/BK) wire at Blower Motor Resistor.</li> </ul>	<ul style="list-style-type: none"> <li>● Check continuity of Blower Motor Resistor.</li> <li>● Check for battery voltage at Blower Motor Resistor at 261 (O/BK) wire and verify ground at 57 (BK) wire. If both are good, check Blower Motor Resistor.</li> </ul>
<ul style="list-style-type: none"> <li>● Blower runs only in LO speed</li> </ul>	<ul style="list-style-type: none"> <li>● Inoperative Blower Motor Switch.</li> <li>● Open 57 (BK) wire at Blower Motor Switch.</li> </ul>	<ul style="list-style-type: none"> <li>● Remove connector from Blower Motor Switch and check continuity of each switch position. Check Blower Motor Switch if any position is open.</li> <li>● Refer to Cell 149 for Switch Testing procedures.</li> <li>● Check 57 (BK) wire at Blower Motor Switch.</li> </ul>

For further diagnostic information, refer to Section 12-02 of the Shop Manual.

### AIR CONDITIONER/HEATER

#### HOW THE CIRCUIT WORKS

The Air Conditioner/Heater System consists of the Function Selector Switch and Vacuum Motor (in the instrument panel), and Compressor and Condenser (in the engine compartment).

The Function Selector Switch and Vacuum Valve operate together to control system vacuum and electrical operation. Vacuum motors operate doors to direct air flow. The Function Selector Switch connects power to the Blower Motor and to the A/C Clutch Field Coil circuit.

The A/C Clutch Cycling Pressure Switch cuts off power to the A/C Clutch Field Coil when there is low refrigerant pressure.

The Temperature Control Lever moves a control cable connected to the Temperature Blend Door, which directs air through and around the Heater Core to obtain the desired air temperature.



BUY IT NOW!

Click Here To Order



# 7-21 TROUBLESHOOTING/DESCRIPTIONS

## SECTION 54 (cont'd)

With the Ignition Switch in RUN and the Function Selector Switch in any position except OFF, voltage is applied to the Blower Motor.

The speed of the Blower Motor is regulated by the Blower Switch and Blower Motor Resistor. With the front Blower Switch in LO, current flows through the Blower Motor and three resistors. In MED-LO, current flows through two resistors. In MED-HI, current flows through one resistor. In HI, current does not flow through any resistors. With the Function Selector Switch in OFF, the Blower Motor does not run.

With the Ignition Switch in RUN and the Function Selector Switch in MAX, NORM (A/C), FLR/DEF or DEFROST, the A/C Clutch Field Coil is activated, and the Compressor starts.

### Lever Position and Operation

OFF - Vacuum is applied to the Outside Recirculate Door Vacuum Motor, closing that

door to outside air. The Panel Door closes the instrument panel outlets. The Floor-Defrost Door opens the floor outlets. The Blower does not operate and air does not pass through the system.

A/C MAX - The Outside Recirculate Door closes to outside air. The Panel Door sends air to the instrument panel outlets (vacuum on motor). With the Temperature Control Lever in the Cool position, the Temperature Blend Door prevents air flow through the Heater Core.

A/C NORM - Outside air comes through the Outside Recirculate Door. The Panel Door sends air to the instrument panel outlets (vacuum on motor). The Temperature Blend Door controls the air through the Heater Core.

VENT - Air flow is the same as in A/C NORM. The compressor is OFF.

FLOOR - Outside air, controlled by the Temperature Control Lever, is passed through or around the Heater Core. The Panel Door is closed and air is sent to the floor outlets (vacuum at ports A and B of the Floor-Defrost Door Vacuum Motor). The compressor is OFF.

FLR/DEF- The Outside-Recirculate Door lets in outside air (no vacuum at motor). Vacuum is applied at port A of the Floor-Defrost Door. The door moves to mid-position and air is split between the floor and defrost outlets. The Panel Door closes and the A/C compressor operates to dehumidify the air.

DEFROST - With no vacuum at any Vacuum Motor, air passes through the outlets. The compressor operates to dehumidify the air.

### TRUBLESHOOTING HINTS

CONDITION	POSSIBLE CAUSE	ACTION
<ul style="list-style-type: none"> <li>Blower runs only in HI.</li> </ul>	<ul style="list-style-type: none"> <li>Open Thermal Limiter in Blower Motor Resistors.</li> </ul>	<ul style="list-style-type: none"> <li>Check continuity of Blower Motor Resistors. Check Blower Motor Resistors if Thermal Limiter is open, and check 57 (BK) and 261 (O/BK) wires.</li> </ul>
<ul style="list-style-type: none"> <li>Hissing sound or air flow from wrong outlets.</li> </ul>	<ul style="list-style-type: none"> <li>Vacuum leak or pinched vacuum tube.</li> </ul>	<ul style="list-style-type: none"> <li>Refer to the Vacuum schematic and "How to Find the Vacuum Problem" Section.</li> </ul>
<ul style="list-style-type: none"> <li>Compressor Clutch doesn't operate.</li> </ul>	<ul style="list-style-type: none"> <li>Open A/C Clutch Field Coil.</li> <li>Open A/C Clutch Cycling Pressure Switch.</li> </ul>	<ul style="list-style-type: none"> <li>With the Function Selector Switch in A/C NORM, remove the connector from the A/C Clutch Field Coil and check for battery voltage between the 347 (BK/Y) and 57 (BK) wires on the connector. If voltage is present, check A/C Clutch Field Coil.</li> <li>Remove connector from A/C Clutch Cycling Pressure Switch and check continuity of Switch. If Switch is open and refrigerant charge is normal, check the A/C Clutch Cycling Pressure Switch.</li> </ul>

**100% SATISFACTION GUARANTEED**

**BUY IT NOW!**

**Click Here To Order**

PayPal American Express Discover MasterCard VISA

### TROUBLESHOOTING HINTS

CONDITION	POSSIBLE CAUSE	ACTION
<ul style="list-style-type: none"> <li>No cooling or not enough cooling (compressor operates).</li> </ul>	<ul style="list-style-type: none"> <li>Loose A/C Compressor drive belt.</li> <li>Temperature Blend Door out of adjustment.</li> </ul>	<ul style="list-style-type: none"> <li>Check drive belt tension.</li> <li>Check operation of temperature control cable (refer to Shop Manual).</li> </ul>
<ul style="list-style-type: none"> <li>Blower runs only in LO.</li> </ul>	<ul style="list-style-type: none"> <li>Inoperative Blower Switch.</li> <li>Loose connection at connector C260.</li> <li>Open 261 (O/BK) wire.</li> </ul>	<ul style="list-style-type: none"> <li>Check continuity of Blower Switch. Refer to Cell 149 for switch testing procedures.</li> <li>Clean and tighten the connection at connector C260.</li> <li>Check 261 (O/BK) wire of Blower Switch.</li> </ul>
<ul style="list-style-type: none"> <li>Blower doesn't run in any mode.</li> </ul>	<ul style="list-style-type: none"> <li>Inoperative Blower Motor.</li> <li>Inoperative Blower Switch.</li> </ul>	<ul style="list-style-type: none"> <li>Set Function Selector Switch to any position except OFF and set Blower Switch to HI. Disconnect the Blower Motor connector and check for battery voltage between the 181 (BR/O) and 261 (O/BK) wires of the harness connector. If voltage is present, check Blower Motor.</li> <li>Check Fuse 1. If fuse is blown, check for a short to ground, or check for a jammed Blower Motor or fan.</li> </ul>

For further diagnostic information, refer to Sections 12-00 and 12-03 of the Shop Manual.

## SECTION 56

### REAR WINDOW DEFROST

#### HOW THE CIRCUIT WORKS

With the Ignition Switch in RUN, the Rear Window Defrost Control is energized through the Ignition Switch. When the Rear Window Defrost Control is released from ON, the solid state circuitry keeps the defrost relay coil energized.

switch ON  
ndow De-

frost Relay and starts the ten minute (approximate) timing cycle. Current then flows to the Rear Window Defrost Grid. When the Rear Window Defrost Control is released from ON, the solid state circuitry keeps the defrost relay coil energized.

Pressing the Rear Window Defrost Control OFF turns off the defrost relay. This removes power from the Rear Window Defrost circuit.

If the OFF switch is not pressed, power will remain on until the time delay runs out. Then the coil will turn off and remove power from the Rear Window Defrost Grid.

# 7-23 TROUBLESHOOTING/DESCRIPTIONS

## SECTION 56 (cont'd)

### TROUBLESHOOTING HINTS

CONDITION	POSSIBLE CAUSE	ACTION
<ul style="list-style-type: none"><li>Rear Window Defrost Grid doesn't defrost window and ON indicator doesn't light.</li></ul>	<ul style="list-style-type: none"><li>No voltage to Rear Window Defrost Control.</li></ul>	<ul style="list-style-type: none"><li>Check Maxi-fuse M.</li><li>With Ignition Switch in RUN, check for voltage at Rear Window Defrost Control, 8 (O/Y) and 37 (Y) wires.</li><li>Check for continuity to ground G201.</li></ul>
<ul style="list-style-type: none"><li>Rear Defrost Indicator lights but defroster doesn't remove frost.</li></ul>	<ul style="list-style-type: none"><li>No voltage to Rear Window Defrost Grid.</li></ul>	<ul style="list-style-type: none"><li>With Rear Window Defrost Switch ON, check for voltage at connector C310.</li><li>Check for continuity to ground G400 from Rear Window Defrost Grid.</li></ul>

For further diagnostic information, refer to Section 01-11 the Shop Manual.

## SECTION 60

### INSTRUMENT CLUSTER

#### HOW THE CIRCUIT WORKS

When the Ignition Switch is in START or RUN, the gasoline and diesel engine gauges and several indicators are powered by Fuse 17 through the 640 (R/Y) wires.

The Instrument Cluster gauges include the following: Fuel, Oil, Temperature, and Tachometer (optional). Each gauge consists of a coil, a magnet and a pointer, which moves in direct proportion to the output of its sender.

Instrument Cluster in vehicles with die-

chometer)

that include two coils. When the gauges are powered, a magnetic field is produced. The field varies in direction and strength according to the resistance of the sender.

#### Fuel Gauge and Fuel Gauges Sender

The Fuel Gauge Sender's resistance controls the magnetic Fuel Gauge's pointer position. The Sender has a resistance of 145 ohms when the fuel tank is full and 22.5 ohms when the fuel tank is empty.

#### Coolant Temperature Gauge and Sender

The Coolant Temperature Sender's resistance controls the Coolant Temperature Gauge's pointer position. The Sender provides

74 ohms of resistance when the engine coolant is cold and 9.7 ohms when the engine is hot.

The diesel engine's Coolant Temperature Gauge uses an overheat switch that closes at approximately 247°F.

#### Oil Pressure Gauge and Oil Pressure Switch

The Oil Pressure Switch controls the magnetic Oil Pressure Gauge's pointer position. The Oil Pressure Switch closes under normal engine operating conditions; the Oil Pressure Switch opens with the engine off and no oil pressure.

**100% SATISFACTION GUARANTEED**

**BUY IT NOW!**

**Click Here To Order**

Payment options: PayPal, American Express, Discover, MasterCard, VISA

### Tachometer (Optional)

The Tachometer is an electrically operated gauge that indicates engine speed in rpm. In vehicles with gasoline engines, the Tachometer receives its voltage pulses from the ignition coil when the engine is running. In vehicles with diesel engines, the engine's speed is indicated by the Engine RPM Sensor.

### Voltmeter

With the Ignition Switch in START or RUN, the Voltmeter measures voltage to indicate the Battery state of charge.

### Programmable Speedometer/Odometer Module

The Programmable Speedometer/Odometer Module includes the Speedometer, the Odometer, and the Trip Odometer, all of which are electronically controlled by a programmable integrated microprocessor. The microprocessor receives a speed signal input from the Differential Speed Sensor (DSS), and uses a programmed conversion constant to convert

the signal to the standard 8000 pulses per mile speed signal output. The Programmable Speedometer/Odometer Module is serviceable only as a unit. It is important to keep the Speedometer face-up since speedometer function will be affected by storage in the face-down position.

For Programmable Speedometer/Odometer Module diagnosis, refer to Section 13-02 of the Shop Manual.

### TRUBLESHOOTING HINTS

CONDITION	POSSIBLE CAUSE	ACTION
<ul style="list-style-type: none"> <li>A gauge pointer doesn't move, or the gauge is inaccurate.</li> </ul>	<ul style="list-style-type: none"> <li>Inoperative sending unit.</li> <li>Open or high resistance or short to ground in wiring.</li> <li>Inoperative gauge.</li> </ul>	<ul style="list-style-type: none"> <li>Check Fuse 17.</li> <li>Check resistance of sending unit.</li> <li>Use a Rotunda Instrument Gauge System Tester 021-00055 (or equivalent) to check sending unit.</li> <li>Check continuity of circuit wiring from gauge to sending unit.</li> <li>Check gauge if sender and wiring are OK.</li> </ul>
<ul style="list-style-type: none"> <li>None of the gauge pointers move.</li> </ul>	<ul style="list-style-type: none"> <li>No voltage to cluster.</li> </ul>	<ul style="list-style-type: none"> <li>Check power to cluster 640 (R/Y) wire.</li> </ul>
<ul style="list-style-type: none"> <li>Tachometer is inoperative or inaccurate.</li> </ul>	<ul style="list-style-type: none"> <li>Poor connections.</li> </ul>	<ul style="list-style-type: none"> <li>Check voltage and ground to Tachometer.</li> <li>Check for poor terminal connections at the cluster clip.</li> <li>Check resistance between terminal 9 on the Instrument Cluster and 11 (T/Y) wire to the Ignition Coil for 10 ohms or less (diesel engines: check connections and continuity of wiring between terminals on the Instrument Cluster and the 11 (T/Y) wire to the Engine RPM Sensor).</li> </ul>
	<ul style="list-style-type: none"> <li>Inoperative switch.</li> </ul>	<ul style="list-style-type: none"> <li>Disconnect the suspect switch. If the indicator goes out, check the switch. If the indicator is still on, check the related circuit for a short to ground.</li> </ul>

**100% SATISFACTION GUARANTEED**

**BUY IT NOW!**

**Click Here To Order**

PayPal American Express Discover MasterCard VISA

# 7-25 TROUBLESHOOTING/DESCRIPTIONS

## SECTION 60 (cont'd)

### TROUBLESHOOTING HINTS

CONDITION	POSSIBLE CAUSE	ACTION
<ul style="list-style-type: none"> <li>A warning indicator won't light when proper conditions are met (except High Beam and Fasten Seat Belt Warning Indicators).</li> </ul>	<ul style="list-style-type: none"> <li>Inoperative switch.</li> <li>Open ground path.</li> <li>Open indicator bulb.</li> </ul>	<ul style="list-style-type: none"> <li>Ground the terminal to the suspect switch. If the indicator lights, check the switch. If the indicator doesn't light, check the lamp and related circuit for an open.</li> </ul>
<ul style="list-style-type: none"> <li>Voltmeter indicates low voltage/no voltage.</li> </ul>	<ul style="list-style-type: none"> <li>Battery voltage low.</li> <li>Wiring and/or connectors.</li> <li>Printed circuit.</li> <li>Blown fuse.</li> <li>Inoperative Voltmeter.</li> </ul>	<ul style="list-style-type: none"> <li>Service battery and/or charging system as required.</li> <li>Check wiring for breaks. Check connectors for tightness and corrosion (battery feed and ground circuits).</li> <li>Check for cracks/breaks in printed circuit.</li> <li>Service circuit short and check fuse.</li> <li>Check Voltmeter.</li> </ul>
<ul style="list-style-type: none"> <li>Voltmeter indicates high voltage.</li> </ul>	<ul style="list-style-type: none"> <li>Battery voltage high.</li> <li>Inoperative Voltmeter.</li> </ul>	<ul style="list-style-type: none"> <li>Service charging system as required.</li> <li>Check Voltmeter.</li> </ul>

For further diagnostic information, refer to Section 13-00 of the Shop Manual.

## SECTION 64

### VEHICLE SPEED SIGNAL

#### HOW THE CIRCUIT WORKS

The Programmable Speedometer/Odometer Module receives a speed signal input from the Differential Speed Sensor (DSS), and uses the signal to convert miles per hour to miles per mile. The module's internal output of the ve-

hicle. The Programmable Speedometer/Odometer Module supplies this signal to all components that require vehicle speed information including the Speed Control Amplifier, the Transmission Electronic Control Assembly (TECA) (with diesel engine), and the Electronic Engine Control (EEC) Module (with gasoline engine).

**100% SATISFACTION GUARANTEED**

**BUY IT NOW!**

**Click Here To Order**

PayPal Discover American Express MasterCard VISA

### TROUBLESHOOTING HINTS

CONDITION	POSSIBLE CAUSE	ACTION
<ul style="list-style-type: none"> <li>Speedometer inoperative; CHECK ENGINE light illuminated and/or Speed Control is inoperative.</li> </ul>	<ul style="list-style-type: none"> <li>No power to Programmable Speedometer/Odometer Module.</li> <li>No vehicle speed input.</li> <li>Open ground.</li> <li>Inoperative Programmable Speedometer/Odometer Module.</li> </ul>	<ul style="list-style-type: none"> <li>Check for voltage at 54 (LG/Y) and 296 (W/P) wires.</li> <li>Check for approximately 3.5 volts AC between pins 4 and 5 of Programmable Speedometer/Odometer Module with vehicle speed approximately 30 mph.</li> <li>Check continuity of 676 (PK/O) wire to ground.</li> <li>Check Module.</li> </ul>

For further diagnostic information, refer to the Powertrain Control/Emissions Diagnosis Manual.

## SECTION 65

### WARNING INDICATORS

#### HOW THE CIRCUIT WORKS

When the Ignition Switch is in START or RUN, the Warning Indicators are powered through Fuse 17.

The Plugged Fuel Filter Indicator illuminates when fuel pressure in the engine exceeds operational limits.

The Wait-to-Start Indicator illuminates for 1 to 15 seconds after the Ignition Switch is placed in the START or RUN position, indicating that the diesel engine is not ready to be started.

The Water-In-Fuel Indicator illuminates when the Ignition Switch is in START or RUN and the Fuel Water Switch senses water in the fuel/water separator sediment bowl.

When water is detected in the fuel/water separator sediment bowl, the bowl must be drained to prevent damage to the fuel injectors. Refer to Shop Manual for draining instructions.

The Engine Warning Indicator illuminates with the Ignition Switch in START as a bulb test and when there is a high coolant temperature condition.



# 7-27 TROUBLESHOOTING/DESCRIPTIONS

## SECTION 65 (cont'd)

### TROUBLESHOOTING HINTS

CONDITION	POSSIBLE CAUSE	ACTION
<ul style="list-style-type: none"> <li>A warning indicator is always on.</li> </ul>	<ul style="list-style-type: none"> <li>Inoperative switch or Glow Plug Controller.</li> <li>Shorted wire or glow plug(s).</li> </ul>	<ul style="list-style-type: none"> <li>Disconnect suspect switch. If indicator goes out, check the switch. If indicator stays on, check continuity of the wire from switch to indicator. Check for a short in the printed circuit board.</li> <li>Disconnect connector from Glow Plug Controller. If indicator goes out, check resistance of glow plugs. If within tolerance, check Controller. If indicator stays on, check continuity of wiring from Controller to indicator.</li> </ul>
<ul style="list-style-type: none"> <li>An indicator is not illuminated when it should be.</li> </ul>	<ul style="list-style-type: none"> <li>Open bulb.</li> <li>Open circuit to controlling component.</li> <li>Open power circuit.</li> </ul>	<ul style="list-style-type: none"> <li>Check bulb.</li> <li>Check continuity of wire from indicator to fuse or Ignition Switch. If good, check fuse and Ignition Switch.</li> <li>Check continuity of wire from indicator to controlling component. If good, check resistance of controlling component.</li> </ul>

For further diagnostic information, refer to Sections 13-03, 13-04, 13-05, 13-09 and 13-10 of the Shop Manual.

## SECTION 66

### WARNING CHIME

#### HOW THE CIRCUIT WORKS

##### Seat Belt Warning

When the Ignition Switch is turned to START or RUN, power is supplied to the Warning Chime Module through circuit 640 (R/Y). Power is supplied through circuit 450 (DG/LG) to the indicator for the driver's seat belt is NOT

fastened during this time, ground is supplied from the Seat Belt Switch through circuit 85 (BR/LB) to the Warning Chime Module, causing it to sound for six seconds.

##### Key-in-Ignition Warning

The warning chime sounds when the driver's door is open and the key is in the Ignition Switch. It continues to sound until the key is removed or the door is closed. When the key is in the ignition, ground is supplied to the Warning Chime Module through circuit 158 (BK/PK). When the driver's door is open, power is

supplied to the Warning Chime Module through circuit 159 (R/PK).

##### Headlamps-On Warning

The warning chime sounds when the Main Light Switch is in PARK or HEAD and the driver's door is open, and continues to sound until the switch is moved to OFF or the door is closed. When the Main Light Switch is in PARK or HEAD, power is supplied through circuit 14 (BR) to the Warning Chime Module. When the driver's door is open, power is supplied to the Module through circuit 159 (R/PK).

**100% SATISFACTION GUARANTEED**

**BUY IT NOW!**

**Click Here To Order**

PayPal American Express Discover MasterCard VISA

### TROUBLESHOOTING HINTS

CONDITION	POSSIBLE CAUSE	ACTION
<ul style="list-style-type: none"> <li>Warning does not sound for any condition.</li> </ul>	<ul style="list-style-type: none"> <li>Warning Chime Module not properly installed to connector.</li> <li>Open circuit in 57 (BK) wire between Warning Chime Module connector and ground G201.</li> </ul>	<ul style="list-style-type: none"> <li>Clean and properly reinstall Warning Chime Module terminals in connector.</li> <li>Remove connector from Warning Chime Module and check for ground at terminal of 57 (BK) wire. If ground is not present, repair 57 (BK) wire.</li> </ul>
<ul style="list-style-type: none"> <li>Warning sounds intermittently for no apparent reason with all doors closed.</li> </ul>	<ul style="list-style-type: none"> <li>Inoperative Left Front Courtesy Lamp Switch.</li> </ul>	<ul style="list-style-type: none"> <li>Remove connector from Warning Chime Module and measure voltage at terminal of 159 (R/PK) wire while the left door is closed. If voltage is 2V or higher, or if switch appears damaged, check switch.</li> </ul>
<ul style="list-style-type: none"> <li>Warning sounds for no apparent reason with left door open (key out of Ignition Switch, Main Light Switch OFF).</li> </ul>	<ul style="list-style-type: none"> <li>Inoperative Ignition Key Warning Switch.</li> <li>Inoperative Main Light Switch.</li> </ul>	<ul style="list-style-type: none"> <li>Remove connector from Warning Chime Module and check for ground at terminal of 158 (BK/PK) wire when key is out of Ignition Switch. If ground is present, check Ignition Key Warning Switch.</li> <li>With Main Light Switch in OFF position, verify 12V is not present at terminal of 14 (BR) wire at Warning Chime Module. If voltage is present, check Main Light Switch.</li> </ul>
<ul style="list-style-type: none"> <li>No fasten belts chime, but Fasten Seat Belt Indicator works normally.</li> </ul>	<ul style="list-style-type: none"> <li>Inoperative Driver's Seat Belt Switch.</li> <li>Open circuit in 85 (BR/LB) wire between Warning Chime Module and Seat Belt Switch.</li> <li>Open circuit in 57 (BK) wire between Seat Belt Switch and ground G201.</li> </ul>	<ul style="list-style-type: none"> <li>Remove connector from Warning Chime Module and check that ground is present at terminal of the 85 (BR/LB) wire when the driver's seat belt is unbuckled. If ground is not present, check Seat Belt Switch, 85 (BR/LB) wire and 57 (BK) wire for an open.</li> </ul>



BUY IT NOW!

Click Here To Order









# 7-29 TROUBLESHOOTING/DESCRIPTIONS

## SECTION 66 (cont'd)

### TROUBLESHOOTING HINTS

CONDITION	POSSIBLE CAUSE	ACTION
<ul style="list-style-type: none"> <li>Fasten Seat Belt Indicator does not illuminate, but fasten belts warning chime works normally.</li> </ul>	<ul style="list-style-type: none"> <li>Fasten Seat Belt Indicator bulb burned out.</li> <li>Open circuit in 450 (DG/LG) wire between Warning Chime Module connector and bulb.</li> <li>Open circuit in 57 (BK) wire between bulb and ground G201.</li> </ul>	<ul style="list-style-type: none"> <li>Check bulb.</li> <li>With the Ignition Switch in OFF, check for ground at terminal of 450 (DG/LG) wire at Warning Chime Module. If ground is not present, check for opens in 450 (DG/LG) wire and 57 (BK) wire between the indicator bulb and ground G201.</li> </ul>
<ul style="list-style-type: none"> <li>No Key-in-Ignition reminder chime.</li> </ul>	<ul style="list-style-type: none"> <li>Fuse 8 blown.</li> <li>Inoperative Ignition Key Warning Switch or open 158 (BK/PK) circuit.</li> <li>Inoperative Left Front Courtesy Lamp Switch or open 159 (R/PK) circuit.</li> </ul>	<ul style="list-style-type: none"> <li>Check Fuse 8.</li> <li>Remove connector from Warning Chime Module and check for ground at terminal of 158 (BK/PK) wire with key in Ignition Switch. If ground is not present, check Ignition Key Warning Switch and 158 (BK/PK) wire.</li> <li>Remove connector from Warning Chime Module and check for battery voltage at terminal of 159 (R/PK) wire when left door is open. If battery voltage is not present, check Left Courtesy Lamp Switch and 159 (R/PK) wire.</li> </ul>
<ul style="list-style-type: none"> <li>No Lights on reminder chime.</li> </ul>	<ul style="list-style-type: none"> <li>Fuse 4 blown.</li> <li>Inoperative Main Light Switch or open circuit in 14 (BR) wire.</li> <li>Inoperative Left Front Courtesy Lamp Switch or open circuit in 159 (R/PK) wire.</li> </ul>	<ul style="list-style-type: none"> <li>Check Fuse 4.</li> <li>Remove connector from Warning Chime Module and check for battery voltage at terminal of 14 (BR) wire with Main Light Switch in PARK or HEAD. If battery voltage is not present, check Main Light Switch and 14 (BR) wire.</li> <li>Remove connector from Warning Chime Module and check for battery voltage at terminal of 159 (R/PK) wire when left door is open. If battery voltage is not present, check Left Door Jamb Switch and 159 (R/PK) wire.</li> </ul>

**100% SATISFACTION GUARANTEED**

**BUY IT NOW!**

**Click Here To Order**

PayPal American Express Discover MasterCard VISA

## SECTION 66 (cont'd)

For further diagnostic information, refer to Section 13-09 of the Shop Manual.

## SECTION 71

### INSTRUMENT ILLUMINATION

#### HOW THE CIRCUIT WORKS

Battery voltage is applied to the Main Light Switch at all times through Fuse 4. When the

Main Light Switch is turned to PARK or HEAD, voltage is applied through the switch to the Instrument Illumination Lamps. The amount of voltage that controls the intensity of the lamps can be adjusted by rotating the Dimmer Switch of the Main Light Switch.

#### TROUBLESHOOTING HINTS

CONDITION	POSSIBLE CAUSE	ACTION
<ul style="list-style-type: none"> <li>No Instrument Lamps light up.</li> </ul>	<ul style="list-style-type: none"> <li>No voltage at 195 (T/W) wire of Main Light Switch.</li> <li>No voltage at 19 (LB/R) wire of lamps.</li> <li>Inoperative Dimmer Switch of Main Light Switch.</li> </ul>	<ul style="list-style-type: none"> <li>Check Fuse 4 and 195 (T/W) wire.</li> <li>Check Fuse 10, wiring, and Main Light Switch.</li> </ul>
<ul style="list-style-type: none"> <li>One lamp doesn't light up.</li> </ul>	<ul style="list-style-type: none"> <li>Blown bulb.</li> <li>Socket corrosion.</li> <li>Open in 19 (LG/R) wire.</li> <li>Open to ground.</li> </ul>	<ul style="list-style-type: none"> <li>Check bulb as required.</li> <li>Clean or check socket.</li> <li>Check 19 (LB/R) wire going to the Lamp in question.</li> <li>Check 57 (BK) wire for a clean path to ground for the suspect lamp.</li> </ul>

For further diagnostic information, refer to Section 13-01 of the Shop Manual.



## BUY IT NOW!

Click Here To Order



# 7-31 TROUBLESHOOTING/DESCRIPTIONS

## SECTION 81

### INTERVAL WIPER/WASHER

#### HOW THE CIRCUIT WORKS

The Interval Wiper/Washer System allows the driver to select LO speed, HI speed, or interval (INT) wiping action. In INT, the wipes can be spaced one to fifteen seconds apart.

During washer operation, with the Wiper Switch in the LO or HI position during washer operation, normal wiping action occurs. If the Wiper Switch is in the OFF or INT position during washer operation, the wipers operate in LO

speed. The wipers will continue to operate in LO speed for a few cycles after the washer button is released to dry off the windshield. The wipers then return to OFF or INT operation.

During Interval operation, the wipers make single low speed wipes separated by a variable length pause of one to fifteen seconds.

When parking is complete, the wiper motor is braked to a stop by shunting the L and C terminals of the motor through the park switch. Braking takes place when the wiper motor switch moves to the PARK position. The wiper

motor L terminal is connected to terminal C through the PARK contact of the wiper motor switch and the deenergized contact of the module relay.

#### TROUBLESHOOTING HINTS

CONDITION	POSSIBLE CAUSE	ACTION
<ul style="list-style-type: none"> <li>Windshield Wipers don't operate.</li> </ul>	<ul style="list-style-type: none"> <li>No voltage to Interval Governor.</li> </ul>	<ul style="list-style-type: none"> <li>Check Circuit Breaker 2.</li> <li>Check 65 (DG) wire for an open to the Interval Governor and Windshield Wiper Motor.</li> </ul>
<ul style="list-style-type: none"> <li>Wipers operate in interval mode with wiper switch in OFF position, but operate normally in all other positions.</li> </ul>	<ul style="list-style-type: none"> <li>Open condition in wiper switch.</li> <li>Open condition in 589 (O) wire.</li> </ul>	<ul style="list-style-type: none"> <li>Check wiper switch.</li> <li>Check 589 (O) wire. If wire is OK, check Interval Governor.</li> </ul>
<ul style="list-style-type: none"> <li>Wipers won't park.</li> </ul>	<ul style="list-style-type: none"> <li>No voltage to park switch.</li> <li>Open condition in park switch.</li> </ul>	<ul style="list-style-type: none"> <li>Check 65 (DG) wire for voltage at Windshield Wiper Motor connector C152.</li> <li>Check 57 (BK) ground wire to ground G100.</li> <li>If above conditions prove acceptable, check park switch.</li> </ul>
<ul style="list-style-type: none"> <li>Windshield Washer Pump Motor inoperative; wipers operate when washer switch is depressed.</li> </ul>	<ul style="list-style-type: none"> <li>Open condition between Interval Governor and Windshield Washer Pump Motor.</li> <li>Inoperative Windshield Washer Pump motor.</li> <li>Open condition in 57 (BK) wire to ground G100.</li> </ul>	<ul style="list-style-type: none"> <li>Check 941 (BK/W) wire and Windshield Washer Pump motor.</li> <li>Check Windshield Washer Pump motor ground wire.</li> </ul>

**100% SATISFACTION GUARANTEED**

**BUY IT NOW!**

**Click Here To Order**

PayPal Discover American Express MasterCard VISA

For further diagnostic information, refer to Section 01-16 of the Shop Manual.

## SECTION 85

### HEADLAMPS

#### HOW THE CIRCUIT WORKS

Battery voltage is applied to the Main Light Switch at all times through Maxi-fuse R . When the Main Light Switch is pulled to HEAD, volt-

age is applied through the Main Light Switch and the Dimmer Switch to the Headlamps. The Headlamps will operate in either HI or LO Beam, depending upon the position of the Dimmer Switch. The Headlamps are permanently grounded through grounds G100 and G101.

When the Dimmer Switch is in HI, voltage is also applied to the Hi Beam Indicator. The Hi Beam Indicator bulb is powered by the 932 (GY/W) circuit.

Canadian vehicles are equipped with Day-time Running Lights. See Section 97 for an explanation of this system.

#### TRUBLESHOOTING HINTS

CONDITION	POSSIBLE CAUSE	ACTION
<ul style="list-style-type: none"> <li>No headlamps, but park lamps function.</li> </ul>	<ul style="list-style-type: none"> <li>No voltage at 15 (R/Y) wire of Dimmer Switch.</li> </ul>	<ul style="list-style-type: none"> <li>Check continuity of wire and Main Light Switch.</li> <li>Check/repair Dimmer Switch.</li> </ul>
<ul style="list-style-type: none"> <li>Hi Beams work; no Low Beams.</li> </ul>	<ul style="list-style-type: none"> <li>Inoperative switch.</li> <li>Open in 13 (R/BK) wire.</li> </ul>	<ul style="list-style-type: none"> <li>Attach a jumper across Dimmer Switch 15 (R/Y) and 13 (R/BK) wires. If lamps light, check Dimmer Switch.</li> <li>Check 13 (R/BK) wire for an open.</li> </ul>
<ul style="list-style-type: none"> <li>Lo Beam headlamps work; no High Beams.</li> </ul>	<ul style="list-style-type: none"> <li>Inoperative switch.</li> <li>Open in 12 (LG/BK) wire.</li> </ul>	<ul style="list-style-type: none"> <li>If Hi Beam Indicator and Hi Beam lamps don't work, check Dimmer Switch.</li> <li>If Hi Beam Indicator works but Hi Beam lamps don't work, check 12 (LG/BK) wire.</li> </ul>
<ul style="list-style-type: none"> <li>Any one headlamp is inoperative.</li> </ul>	<ul style="list-style-type: none"> <li>Open bulb.</li> <li>No voltage to inoperative headlamp.</li> <li>Open ground circuit to inoperative headlamp.</li> </ul>	<ul style="list-style-type: none"> <li>Check headlamp bulb continuity.</li> <li>Check headlamp bulb socket for voltage.</li> <li>Check headlamp bulb socket for continuity to ground.</li> </ul>

**100% SATISFACTION GUARANTEED**

**BUY IT NOW!**

**Click Here To Order**

PayPal Discover American Express MasterCard VISA

# 7-33 TROUBLESHOOTING/DESCRIPTIONS

## SECTION 85 (cont'd)

### TROUBLESHOOTING HINTS

CONDITION	POSSIBLE CAUSE	ACTION
<ul style="list-style-type: none"> <li>All Right Headlamps light dimly or don't light; Left headlamps are OK.</li> </ul>	<ul style="list-style-type: none"> <li>Open ground circuit.</li> </ul>	<ul style="list-style-type: none"> <li>Check continuity to ground.</li> </ul>
<ul style="list-style-type: none"> <li>All Left Headlamps light dimly or don't light.</li> </ul>	<ul style="list-style-type: none"> <li>Open ground circuit.</li> </ul>	<ul style="list-style-type: none"> <li>Check continuity to ground.</li> </ul>

For further diagnostic information, refer to Section 17-01 of the Shop Manual.

## SECTION 89

### COURTESY LAMPS

#### HOW THE CIRCUIT WORKS

Voltage is applied at all times through Fuse 8 to the Main Light Switch, Door Jamb Switches, Glove Compartment Lamp, Map Lamps, and the Cargo Lamp.

When the Main Light Switch is turned fully counterclockwise, or if the left or right doors are opened, the Dome Lamp is energized and lights up.

The Map Lamps are energized independently of the Dome Lamp by two switches--one located at each Map Lamp housing.

#### F Series with Cargo Lamp

The Cargo Lamp can be turned on in several ways. It can be turned on manually. It can be turned on when the Main Light Switch is turned fully counterclockwise, or it can be turned on when either the left or right door is opened.

### TROUBLESHOOTING HINTS

CONDITION	POSSIBLE CAUSE	ACTION
<ul style="list-style-type: none"> <li>Any one lamp doesn't light up.</li> </ul>	<ul style="list-style-type: none"> <li>Open bulb.</li> <li>Open ground circuit.</li> <li>No power to bulb.</li> </ul>	<ul style="list-style-type: none"> <li>Check bulb continuity.</li> <li>Check for voltage on bulb socket.</li> <li>Check for continuity from bulb socket to ground.</li> </ul>
<ul style="list-style-type: none"> <li>Lamps with common power supply don't light up.</li> </ul>	<ul style="list-style-type: none"> <li>No voltage at common point.</li> <li>Open power circuit.</li> </ul>	<ul style="list-style-type: none"> <li>Check for an open Fuse 8.</li> <li>Check continuity of wiring from Fuse 8 to Dome Lamps.</li> </ul>
	<ul style="list-style-type: none"> <li>Inoperative Courtesy Lamp Switch.</li> </ul>	<ul style="list-style-type: none"> <li>Check continuity of wiring from Fuse 8 to Courtesy Lamp Switch.</li> <li>Check continuity of Courtesy Lamp Switch in OPEN and CLOSED positions.</li> </ul>

**100% SATISFACTION GUARANTEED**

**BUY IT NOW!**

**Click Here To Order**



For further diagnostic information, refer to Sections 01-05 and 17-02 of the Shop Manual.

### TURN/STOP/HAZARD LAMPS

#### HOW THE CIRCUIT WORKS

##### Turn Signals

With the Ignition Switch in RUN, current flows through Fuse 7, the Turn Flasher, the Multi-function Switch, and on to the Turn Lamps and Indicators.

The Turn Switch sends power to either the Left or Right Turn Lamps.

##### Hazard Flasher

Current flows through Fuse 13 to the Turn Lamps and Indicators when the Hazard Switch is pulled out.

The Hazard Switch sends pulsing current to both the Right and Left Turn Lamps at the same time.

##### Stop Lamps

Current flows through Fuse 13 to the Rear Park/Stop/Turn Lamps and the High Mount Stop Lamp when the Stop Lamp Switch is closed.

#### TROUBLESHOOTING HINTS

CONDITION	POSSIBLE CAUSE	ACTION
<ul style="list-style-type: none"> <li>Some turn lamps work and all hazard lamps work; some hazard lamps work and all turn lamps work; hazard lamps don't turn off.</li> </ul>	<ul style="list-style-type: none"> <li>Inoperative switch or wire in Multi-function Switch.</li> </ul>	<ul style="list-style-type: none"> <li>Check Multi-function Switch.</li> </ul>
<ul style="list-style-type: none"> <li>One of the turn indicators goes on when the park lamps are on.</li> </ul>	<ul style="list-style-type: none"> <li>Inoperative lamp or ground.</li> </ul>	<ul style="list-style-type: none"> <li>Check the front turn lamp on that side.</li> </ul>
<ul style="list-style-type: none"> <li>All stop lamps stay on without the brake pedal depressed.</li> </ul>	<ul style="list-style-type: none"> <li>Inoperative Stop Lamp Switch.</li> </ul>	<ul style="list-style-type: none"> <li>Check Stop Lamp Switch.</li> <li>Check vacuum dump valve adjustment.</li> <li>Check brake pedal pivot for binding condition (must move freely when not connected to booster).</li> </ul>



**BUY IT NOW!**  
Click Here To Order



# 7-35 TROUBLESHOOTING/DESCRIPTIONS

## SECTION 90 (cont'd)

### TROUBLESHOOTING HINTS

CONDITION	POSSIBLE CAUSE	ACTION
<ul style="list-style-type: none"> <li>Hazard lamps don't work; turn lamps do work.</li> </ul>	<ul style="list-style-type: none"> <li>No voltage at Multi-function Switch.</li> </ul>	<ul style="list-style-type: none"> <li>Check 383 (R/W) and 385 (W/R) wires.</li> <li>Check Hazard Flasher.</li> <li>Check Multi-function Switch.</li> </ul>
<ul style="list-style-type: none"> <li>No turn lamps work; hazard lamps do work.</li> </ul>	<ul style="list-style-type: none"> <li>No voltage at Multi-function Switch.</li> </ul>	<ul style="list-style-type: none"> <li>Check 8 (O/Y) and 44(LB) wires for open connection.</li> <li>Check Turn Signal Flasher.</li> <li>Check Multi-function Switch.</li> </ul>
<ul style="list-style-type: none"> <li>Rear turn lamps on one side don't work; hazard and/or stop lamps do work.</li> </ul>	<ul style="list-style-type: none"> <li>Inoperative Multi-function Switch.</li> </ul>	<ul style="list-style-type: none"> <li>Check Multi-function Switch.</li> </ul>
<ul style="list-style-type: none"> <li>Front turn lamp and turn indicator on one side don't work.</li> </ul>	<ul style="list-style-type: none"> <li>No voltage from Multi-function Switch.</li> </ul>	<ul style="list-style-type: none"> <li>Check Multi-function Switch.</li> <li>Check 3 (LG/W) (for left side) or 2 (W/LB) (for right side) wire for an open.</li> </ul>
<ul style="list-style-type: none"> <li>Turn lamps stay on (don't flash) for both left or right turn.</li> </ul>	<ul style="list-style-type: none"> <li>Inoperative Turn Flasher.</li> </ul>	<ul style="list-style-type: none"> <li>Check the Turn Flasher.</li> </ul>
<ul style="list-style-type: none"> <li>Hazard lamps stay on (don't flash) in HAZARD, but the stop lamps go off normally.</li> </ul>	<ul style="list-style-type: none"> <li>Inoperative Hazard Flasher.</li> </ul>	<ul style="list-style-type: none"> <li>Check the Hazard Flasher.</li> </ul>
<ul style="list-style-type: none"> <li>Stop lamps do not work, but turn and hazard lamps do work.</li> </ul>	<ul style="list-style-type: none"> <li>Inoperative Stop Lamp Switch.</li> <li>No voltage to Multi-function Switch.</li> </ul>	<ul style="list-style-type: none"> <li>Check the 511 (LG) wire for continuity.</li> <li>Check Stop Lamp Switch.</li> </ul>

For further diagnostic information, refer to Section 17-01 of the Shop Manual.

**100% SATISFACTION GUARANTEED**

**BUY IT NOW!**

**Click Here To Order**

PayPal Discover American Express MasterCard VISA

### EXTERIOR LAMPS

Lamps light when the Main Light Switch is moved to the PARK or HEAD position. Fuse 4 is hot at all times, which allows the driver to leave the Exterior Lamps on whenever necessary.

### HOW THE CIRCUIT WORKS

The Exterior lamps are powered through Fuse 4 and the Main Light Switch. The Exterior

The Engine Lamp is powered directly from Fuse 8 in the Fuse Panel.

### TROUBLESHOOTING HINTS

CONDITION	POSSIBLE CAUSE	ACTION
<ul style="list-style-type: none"> <li>Any one lamp doesn't light.</li> </ul>	<ul style="list-style-type: none"> <li>Open bulb.</li> <li>Open ground circuit.</li> </ul>	<ul style="list-style-type: none"> <li>Check bulb socket for voltage with Main Light Switch in PARK or HEAD.</li> <li>Check bulb continuity.</li> <li>Check bulb socket contact for continuity to ground.</li> </ul>
<ul style="list-style-type: none"> <li>Lamps with common power supply don't light.</li> </ul>	<ul style="list-style-type: none"> <li>No voltage to common point.</li> </ul>	<ul style="list-style-type: none"> <li>Check fuse and switch supplying common circuit.</li> <li>Check wiring to common point.</li> </ul>
<ul style="list-style-type: none"> <li>Lamps with common ground supply don't light.</li> </ul>	<ul style="list-style-type: none"> <li>High resistance ground circuit.</li> </ul>	<ul style="list-style-type: none"> <li>Check for continuity between common point and ground.</li> </ul>
<ul style="list-style-type: none"> <li>All lamps are inoperative.</li> </ul>	<ul style="list-style-type: none"> <li>Blown Fuse 4.</li> <li>Open in 195 (T/W) wire.</li> <li>Inoperative Main Light Switch.</li> </ul>	<ul style="list-style-type: none"> <li>Check Fuse 4.</li> <li>Check 195 (T/W) wire for a break or a short to ground.</li> <li>Check the Main Light Switch according to Component Testing Procedures in cell 149.</li> </ul>

For further diagnostic information, refer to Section 17-01 of the Shop Manual.



# 7-37 TROUBLESHOOTING/DESCRIPTIONS

## SECTION 93

### BACKUP LAMPS

#### HOW THE CIRCUIT WORKS

With the Ignition Switch in RUN, voltage is applied from Fuse E, in the Engine Compart-

ment Fuse Box, to the Manual Lever Position Sensor (E4OD), Backup/Neutral Safety Switch (C6 or AOD) or Backup Lamp Switch (MTX). With the switch closed, voltage is applied to the Backup Lamps through the 140 (BK/PK) wires.

#### TROUBLESHOOTING HINTS

CONDITION	POSSIBLE CAUSE	ACTION
<ul style="list-style-type: none"><li>Backup Lamps are inoperative.</li></ul>	<ul style="list-style-type: none"><li>No voltage to lamps.</li><li>Open ground circuit.</li></ul>	<ul style="list-style-type: none"><li>Check for voltage at the Backup Lamp 140 (BK/PK) circuit and 298 (P/O) circuit.</li><li>Check continuity of 57 (BK) circuit to ground.</li><li>With vehicle in RUN, attach a jumper across the Backup/Neutral Safety Switch (C6 or AOD), Manual Lever Position Sensor (E4OD) or Backup Lamp Switch (MTX). If Backup Lamps work, check switch or sensor.</li></ul> <p><b>CAUTION:</b> Connect jumper to backup lamp circuit only. Accidental connection to other circuits may cause damage to the EEC System.</p>
<ul style="list-style-type: none"><li>Backup Lamps stay on.</li></ul>	<ul style="list-style-type: none"><li>Short in circuit.</li></ul>	<ul style="list-style-type: none"><li>Check switch or sensor.</li></ul>

For further diagnostic information, refer to Section 17-01 of the Shop Manual.

## SECTION 95

### TRAILER ADAPTER

#### HOW THE CIRCUIT WORKS

Wires for the Trailer circuits and all the trailer-  
Compart-

ment Fuse Box. Trailer Marker Lamps and Trailer Backup Lamps are powered through Fuse D. Trailer brakes are powered through Maxi-fuse T. The Turn/Stop/Hazard Lamps are powered through Fuse F and Fuse G. The trail-

er battery charge circuit is powered through Maxi-fuse Q.

**100% SATISFACTION GUARANTEED**

**BUY IT NOW!**

Click Here To Order

PayPal American Express Discover MasterCard VISA

### TROUBLESHOOTING HINTS

CONDITION	POSSIBLE CAUSE	ACTION
<ul style="list-style-type: none"> <li>Trailer Lamps don't work.</li> </ul>	<ul style="list-style-type: none"> <li>No voltage to trailer lights.</li> <li>Open in circuits.</li> <li>Possible inoperative relay.</li> </ul>	<ul style="list-style-type: none"> <li>Check Fuses D, F, and G.</li> <li>Check for voltage at relays.</li> <li>Check for an open, loose, or corroded connector.</li> </ul>
<ul style="list-style-type: none"> <li>Trailer Lamps remain on continuously.</li> </ul>	<ul style="list-style-type: none"> <li>Relay stuck in closed position or short in wiring.</li> </ul>	<ul style="list-style-type: none"> <li>Check relay.</li> </ul>
<ul style="list-style-type: none"> <li>Trailer Stop Lamps don't work and/or Trailer Electric Brakes don't work.</li> </ul>	<ul style="list-style-type: none"> <li>No voltage to connector C210 or inoperative Trailer Brake Control (customer installed).</li> </ul>	<ul style="list-style-type: none"> <li>Check Maxi-fuse T.</li> <li>Check for voltage at connector C210, 50 (R) circuit. If voltage is present, check Trailer Brake Control circuit (customer installed).</li> </ul>

For further diagnostic information, refer to Section 02-04 of the Shop Manual.

## SECTION 97

### DAYTIME RUNNING LAMPS (CANADIAN VEHICLES ONLY)

#### HOW THE CIRCUIT WORKS

The Daytime Running Lamps (DRL) System operates the vehicle's High Beam Headlamps at reduced power during the daytime to make the vehicle more visible to other drivers.

With the Ignition Switch in RUN, the park brake released, and the Headlamps turned ON, the DRL Module outputs a pulsing voltage to the High Beam Headlamps.

at reduced intensity. When the DRL System is operating, the Hi Beam Indicator is not illuminated.

Applying the park brake or turning on the Headlamps disables the DRL System. Applying the park brake grounds pin 6 of the DRL Module. Turning on the Headlamps in the low beam position applies battery voltage to pin 7 of the Module (and removes the ground input that the DRL Module senses through the Low Beam Headlamps). Turning on the Headlamps in the high beam position applies 12 volts to pin 8 of the DRL Module.

The DRL System is used only on vehicles sold in Canada.

#### NOTE:

The headlamps may flicker during engine start-up and shut-down on DRL-equipped vehicles if the A/C-Heater Blower Motor is turned ON. This is a normal condition.

Also, during Low Beam Headlamp operation on a DRL-equipped vehicle, the Hi Beam Indicator will not illuminate when using the flash-to-pass feature.

**100% SATISFACTION GUARANTEED**

**BUY IT NOW!**

**Click Here To Order**

PayPal American Express Discover MasterCard VISA

# 7-39 TROUBLESHOOTING/DESCRIPTIONS

## SECTION 97 (cont'd)

### TROUBLESHOOTING HINTS

CONDITION	POSSIBLE CAUSE	ACTION
<ul style="list-style-type: none"> <li>Daytime Running Lamps don't operate.</li> </ul>	<ul style="list-style-type: none"> <li>Blown fuse.</li> <li>Open ground connection.</li> <li>22 (LB/BK) wire shorted to ground.</li> <li>Inoperative Daytime Running Lamps (DRL) Module.</li> </ul>	<ul style="list-style-type: none"> <li>Check Fuse A and Fuse E.</li> <li>Check ground connections.</li> <li>With Park Brake disengaged, check for a short between the 22 (LB/BK) wire and ground. If there is a short, repair 22 (LB/BK) wires.</li> <li>With the ignition in RUN, check for voltage at the 38 (BK/O) and 298 (P/O) wires.</li> <li>Check for voltage at the 12 (LG/BK) wire with the Ignition Switch in RUN, Brake disengaged and Headlamps off. If no voltage is present, check Module. If voltage is OK, repair 12 (LG/BK) wire.</li> </ul>
<ul style="list-style-type: none"> <li>Daytime Running Lamps won't turn off with Main Light Switch in HEAD.</li> </ul>	<ul style="list-style-type: none"> <li>Open in 13 (R/BK) park wire.</li> <li>Inoperative Daytime Running Lamps Module.</li> </ul>	<ul style="list-style-type: none"> <li>With Main Light Switch in HEAD and Dimmer Switch in LO, check for voltage on the 13 (R/BK) wire. If voltage is present, check Module. If voltage is not present, check 13 (R/BK) for shorts to ground or an open.</li> </ul>

For further diagnostic information, refer to Section 17-01 of the Shop Manual.

## SECTION 100

### POWER WINDOWS

#### HOW THE CIRCUIT WORKS

##### Power Windows

When the Ignition Switch is in ACC or RUN, Master and Right Window Control Switches are energized.

and in either  
m Circuit

Breaker 14 causes the window motor(s) to operate in a clockwise or counterclockwise direction, raising or lowering the window(s).

In the REST position, both motor wires are grounded through separate switch contacts.

When the DN switch is pushed, power flows to the DN motor lead. The UP lead acts as ground.

When the UP switch is pushed, power flows to the UP motor lead. The DN lead acts as ground.

The Power Windows are protected by Circuit Breaker 14. Each motor assembly also has a self-resetting circuit breaker to cut off power if a switch is held too long in the UP or DN position.

**100% SATISFACTION GUARANTEED**

**BUY IT NOW!**

**Click Here To Order**

PayPal American Express Discover MasterCard VISA

## SECTION 100 (cont'd)

### Tailgate Power Window (Bronco Only)

The Master Tailgate Window Switch, located on the Instrument Panel, is powered by Circuit Breaker 14 when the Ignition Switch is in ACC or RUN. The Tailgate Power Window can also be controlled by a key-operated Tailgate Window Switch, powered at all times by Circuit Breaker 12.

Either switch assembly can send current through the Tailgate Power Window Motor, causing the Motor to turn in a clockwise or counterclockwise direction, raising or lowering the window in a manner identical to that of the Right and Left Power Window Motors. In the REST position, both wires are grounded through separate contacts.

The Tailgate Power Window Motor includes an internal circuit breaker to cut off power if a switch is held too long in the UP or DN position. The Tailgate Latch Switch prevents the Tailgate Power Window Motor from operating when the tailgate is open.

### TROUBLESHOOTING HINTS

CONDITION	POSSIBLE CAUSE	ACTION
<ul style="list-style-type: none"> <li>The Left and Right Power Windows don't operate.</li> </ul>	<ul style="list-style-type: none"> <li>No voltage on 400 (LB/BK) wires to Master Window Control Switch.</li> <li>Loose or open ground G201.</li> <li>Inoperative Master Window Control Switch.</li> </ul>	<ul style="list-style-type: none"> <li>Check for battery voltage at 400 (LB/BK) wires of Master Window Control Switch connector. If voltage isn't present, check Circuit Breaker 14 and continuity of 400 (LB/BK) wires.</li> <li>Check that ground G201 is clean and tight. Perform continuity checks on 57 (BK) wires.</li> <li>Place a test lamp between 227 (Y) and 226 (R) wires at the Master Window Control Switch connector while Left Window Switch is in UP and DN positions. If lamp doesn't light, check Master Window Control Switch.</li> </ul>
<ul style="list-style-type: none"> <li>Circuit Breaker 14 opens when one window is operated.</li> </ul>	<ul style="list-style-type: none"> <li>Excessive current drawn by Window Motor.</li> </ul>	<ul style="list-style-type: none"> <li>Perform current draw test in Section 42-08 of the Shop Manual.</li> </ul>
<ul style="list-style-type: none"> <li>One Window Motor doesn't operate.</li> </ul>	<ul style="list-style-type: none"> <li>Inoperative Window Control Switch or Window Motor.</li> </ul>	<ul style="list-style-type: none"> <li>Check for voltage at Window Motor. Using a test lamp, check for operation with switch in UP and DN positions. If voltage isn't present, check wiring from motor to Control Switch and operation of switch.</li> <li>Check for power to switch. If voltage isn't present, check circuit Breaker 14 and continuity of related wiring.</li> </ul>



## BUY IT NOW!

Click Here To Order







# 7-41 TROUBLESHOOTING/DESCRIPTIONS

## SECTION 100 (cont'd)

### TROUBLESHOOTING HINTS

CONDITION	POSSIBLE CAUSE	ACTION
<ul style="list-style-type: none"><li>• Tailgate Window Switch (key operated) doesn't operate.</li></ul>	<ul style="list-style-type: none"><li>• Open in Tailgate Latch Switch.</li><li>• No voltage on 517 (BK/W) wires.</li><li>• Inoperative Tailgate Window Switch, Window Motor.</li></ul>	<ul style="list-style-type: none"><li>• Check for voltage on Circuit Breaker 12.</li><li>• Check for voltage on 517 (BK/W) wires to Tailgate Window Switch.</li><li>• Check continuity between 407 (T/BK) and 334 (R/Y) wires, on Tailgate Latch Switch with Tailgate open and closed. When open, the switch should appear as an open circuit. When closed, the switch should appear as a short.</li><li>• Using a test lamp, check for voltage on Tailgate Power Window Motor with Tailgate Window Switch in UP and DN positions. If voltage isn't present, check continuity of wires to Window Control Switch.</li></ul>

For further diagnostic information, refer to Sections 01-11A and 01-14A of the Shop Manual.

## SECTION 110

### POWER DOOR LOCKS

#### HOW THE CIRCUIT WORKS

The Power Door Locks are powered at all times by Circuit Breaker 12. When either the Left or Right Door Lock Control Switch is placed in the LOCK position, current flows from

Circuit Breaker 12, through the 171 (BK/W) wire, the closed switch contacts, and the 118 (PK/O) wires to the Door Lock Motors, locking all the Doors.

When either the Left or Right Door Lock Control Switch is placed in the UNLOCK position, current flows from Circuit Breaker 12, through the 171 (BK/W) wire, the closed switch

contacts, and the 117 (PK/BK) wires to the Door Lock Motors, causing the Door Lock Motors to reverse direction and unlock all the doors.

In the REST position, both Door Lock Motors are grounded through separate switch contacts.



### TROUBLESHOOTING HINTS

CONDITION	POSSIBLE CAUSE	ACTION
<ul style="list-style-type: none"> <li>● Power Door Locks work from one Door Lock Control Switch only.</li> </ul>	<ul style="list-style-type: none"> <li>● Inoperative Door Lock Control Switch.</li> <li>● Open power feed to Door Lock Control Switch.</li> </ul>	<ul style="list-style-type: none"> <li>● Check for voltage on 171 (BK/W) wire at suspect Door Lock Control Switch.</li> </ul>
<ul style="list-style-type: none"> <li>● Power Door Locks are completely inoperative.</li> </ul>	<ul style="list-style-type: none"> <li>● No voltage to Right and Left Door Lock Control Switches.</li> <li>● Open in Door Lock Motor circuit.</li> </ul>	<ul style="list-style-type: none"> <li>● Check Circuit Breaker 12.</li> <li>● Check for voltage on 171 (BK/W) wire at Right and Left Door Lock Control Switches.</li> <li>● Check continuity of the 117 (PK/BK) and 118 (PK/O) wires.</li> </ul>
<ul style="list-style-type: none"> <li>● Locks work in LOCK or UNLOCK, but not in both positions.</li> </ul>	<ul style="list-style-type: none"> <li>● Open in 57 (BK) wires.</li> <li>● Open in 120 (PK/LG) and 627 (BK/O) wires.</li> </ul>	<ul style="list-style-type: none"> <li>● Check continuity of 57 (BK) wires.</li> <li>● Check continuity of 120 (PK/LG) and 119 (PK/Y) wires.</li> </ul>
<ul style="list-style-type: none"> <li>● Only one Door Lock Motor does not work.</li> </ul>	<ul style="list-style-type: none"> <li>● Inoperative Door Lock Motor.</li> <li>● Open in 117 (PK/BK) or 118 (PK/O) wires.</li> </ul>	<ul style="list-style-type: none"> <li>● Place test lamp across motor. Test lamp should light up in LOCK and UNLOCK switch positions. If OK, check motor.</li> <li>● Check continuity of 117 (PK/BK) and 118 (PK/O) wires.</li> </ul>

For further diagnostic information, refer to Section 01-14A of the Shop Manual.

### POWER LUMBAR SEATS

#### HOW THE CIRCUIT WORKS

With Circuit Breaker 12 hot at all times, volt-  
applied to the Power Lumbar Switch.

Each Lumbar Seat has a switch that changes cushion shape by operating an air pump. Operating the switch in one direction causes the compressor to inflate the bladder;

operating the switch in the other direction causes a bleeder valve to deflate the bladder.



BUY IT NOW!

Click Here To Order



# 7-43 TROUBLESHOOTING/DESCRIPTIONS

## SECTION 122 (cont'd)

### TROUBLESHOOTING HINTS

CONDITION	POSSIBLE CAUSE	ACTION
<ul style="list-style-type: none"> <li>One Lumbar Seat is inoperative.</li> </ul>	<ul style="list-style-type: none"> <li>Open in power feed to Lumbar Switch.</li> <li>Open feed wire from switch to compressor.</li> <li>Inoperative Power Lumbar Switch.</li> <li>Open ground feed to Compressor Motor.</li> <li>Inoperative Compressor Motor.</li> </ul>	<ul style="list-style-type: none"> <li>Measure voltage at 171 (BK/W) wire of Power Lumbar Switch connector.</li> <li>Check continuity of 57 (BK) wire to ground.</li> <li>Measure voltage across disconnected Power Lumbar Compressor Motor connector with Power Lumbar Switch in ON position. If battery voltage is present, check the Power Lumbar Compressor Motor. If voltage is not present, check continuity of the Power Lumbar Switch.</li> </ul>
<ul style="list-style-type: none"> <li>Both Lumbar Seats are inoperative.</li> </ul>	<ul style="list-style-type: none"> <li>No voltage at Power Lumbar Switches.</li> </ul>	<ul style="list-style-type: none"> <li>Check Circuit Breaker 12 for an open.</li> <li>Check 171 (BK/W) wires for an open.</li> </ul>

For further diagnostic information, refer to Section 01-10 of the Shop Manual.

## SECTION 124

### POWER MIRRORS

#### HOW THE CIRCUIT WORKS

Each Power Mirror is equipped with two motors operated by a single joystick-type Direc-

tional Control Switch. The Directional Control Switch directs current to the motors. By reversing current flow, each motor operates horizontally (left and right) and vertically (up and down).

The Left And Right Mirror Switch connects the Directional Control Switch to either the Left or Right Power Mirror.

**100% SATISFACTION GUARANTEED**

**BUY IT NOW!**

**Click Here To Order**

PayPal American Express Discover MasterCard VISA

### TROUBLESHOOTING HINTS

CONDITION	POSSIBLE CAUSE	ACTION
<ul style="list-style-type: none"> <li>Power Mirrors are completely inoperative.</li> </ul>	<ul style="list-style-type: none"> <li>No voltage at Power Mirror Switch.</li> <li>Open ground circuit.</li> </ul>	<ul style="list-style-type: none"> <li>Check Fuse 8 for an open.</li> <li>Check for voltage at connector C550, 54 (LG/Y) wire.</li> <li>Check continuity to ground G201, 57 (BK) wire.</li> </ul>
<ul style="list-style-type: none"> <li>Left Mirror operates properly; Right Mirror operates in LEFT/RIGHT positions but is inoperative in UP/DOWN positions.</li> </ul>	<ul style="list-style-type: none"> <li>No voltage to Right Mirror UP/DN Motor.</li> <li>Inoperative Power Mirror Switch.</li> <li>Inoperative motor assembly.</li> </ul>	<ul style="list-style-type: none"> <li>With the selector in RIGHT position, connect a test lamp between 544 (P) wire and 542 (Y) wire at connector C550. Move knob between UP and DOWN positions. If lamp doesn't light in one or both positions, replace Power Mirror Switch. If lamp lights in both positions, retest at power mirror connector. If lamp lights in both positions at power mirror connectors, check motor assembly. If lamp doesn't light, check 544 (P) wire and 542 (Y) wire for an open. Repair as needed.</li> </ul>
<ul style="list-style-type: none"> <li>Left Mirror operates properly; Right Mirror operates in UP/DOWN positions but is inoperative in LEFT/RIGHT positions.</li> </ul>	<ul style="list-style-type: none"> <li>No voltage to Left Power Mirror L/R Motor.</li> <li>Inoperative Power Mirror Switch.</li> <li>Inoperative motor assembly.</li> </ul>	<ul style="list-style-type: none"> <li>With the selector in RIGHT position, connect a test lamp between 543 (DG) wire and 542 (Y) wire at connector C550. Move knob between Left and Right positions. If lamp doesn't light in one or both positions, replace Power Mirror Switch. If lamp lights in both positions, retest at power mirror connector. If lamp lights in both positions at power mirror connector, check motor assembly. If lamp doesn't light, check 543 (DG) wire and 542 (Y) wire for an open. Repair as needed.</li> </ul>
<ul style="list-style-type: none"> <li>Right Mirror operates properly; Left Mirror operates in LEFT/RIGHT positions but is inoperative in UP/DOWN positions.</li> </ul>	<ul style="list-style-type: none"> <li>No voltage to Left Power Mirror UP/DN Motor.</li> <li>Inoperative Power Mirror Switch.</li> <li>Inoperative motor assembly.</li> </ul>	<ul style="list-style-type: none"> <li>Follow "ACTION" procedures of Right Mirror UP/DN, but use circuit number 541 (DB) in place of 544 (P).</li> </ul>
<ul style="list-style-type: none"> <li>Right Mirror operates properly; Left Mirror operates in UP/DOWN positions but is inoperative in LEFT/RIGHT positions.</li> </ul>	<ul style="list-style-type: none"> <li>No voltage to Left Power Mirror L/R Motor.</li> <li>Inoperative Power Mirror Switch.</li> <li>Inoperative motor assembly.</li> </ul>	<ul style="list-style-type: none"> <li>Follow "ACTION" procedures of Right Mirror L/R, but use circuit number 540 (R) in place of 543 (DG).</li> </ul>



BUY IT NOW!

Click Here To Order









# 7-45 TROUBLESHOOTING/DESCRIPTIONS

## SECTION 124 (cont'd)

For further diagnostic information, refer to Section 01-09 of the Shop Manual.

## SECTION 130

### RADIO

#### HOW THE CIRCUIT WORKS

With the Ignition Switch in ACC or RUN, voltage is applied through Fuse 11 to operate the Radio.

Fuse 8 applies voltage to the Radio at all times to power the memory-related functions,

which retain the memory portions with the Radio turned off.

Panel dimming is controlled by the instrument panel dimming switch. A variable voltage is applied through the 19 (LB/R) wire to control the brightness of the panel lamps.

The display's brightness is controlled by the Main Light Switch. When the park lamps are turned on, battery voltage is applied to the Radio through the 484 (O/BK) wire. The display will dim. When the park lamps are turned off, voltage is no longer reduced by the dimmer resistor and the display will brighten.

#### TROUBLESHOOTING HINTS

CONDITION	POSSIBLE CAUSE	ACTION
<ul style="list-style-type: none"><li>Panel dimming lamps don't light or dim properly.</li></ul>	<ul style="list-style-type: none"><li>Open 19 (LB/R) wire.</li><li>Inoperative Radio.</li></ul>	<ul style="list-style-type: none"><li>Check for voltage in 19 (LB/R) wire at Radio connector with headlamps on and dimming switch set at maximum.</li><li>If voltage isn't present, check 19 (LB/R) for an open. If voltage is present, remove Radio for service.</li></ul>
<ul style="list-style-type: none"><li>Display doesn't light with headlamps on or off.</li></ul>	<ul style="list-style-type: none"><li>Open 484 (O/BK) wire.</li><li>Inoperative Radio.</li></ul>	<ul style="list-style-type: none"><li>Check for voltage in 484 (O/BK) wire at Radio connector with headlamps ON (with Headlamps ON, voltage is reduced with dimming switch).</li><li>If voltage isn't present, repair 484 (O/BK) for an open. If voltage is present, remove Radio for service.</li></ul>



### TROUBLESHOOTING HINTS

CONDITION	POSSIBLE CAUSE	ACTION
<ul style="list-style-type: none"> <li>Radio doesn't appear to work. No sound from any Speaker.</li> </ul>	<ul style="list-style-type: none"> <li>Speaker connection.</li> <li>Antenna or cable.</li> <li>Loss of power or ground.</li> <li>Inoperative Radio.</li> </ul>	<ul style="list-style-type: none"> <li>Check Speaker connection at Radio.</li> <li>Check Antenna and Antenna cable for clean and tight connections. Refer to Section 35-01 of the Shop Manual for Antenna testing procedures.</li> <li>Check for battery voltage in 54 (LG/Y) wire at Radio.</li> <li>Check for battery voltage in 137 (Y/BK) wire at Radio (and amplifier if so equipped) with Ignition Switch in RUN.</li> <li>Check 694 (R) wire continuity to ground.</li> <li>Remove Radio for service if above checks don't correct condition.</li> </ul>
<ul style="list-style-type: none"> <li>One Speaker doesn't work.</li> </ul>	<ul style="list-style-type: none"> <li>Open Speaker.</li> <li>Open or shorted Speaker leads.</li> </ul>	<ul style="list-style-type: none"> <li>Disconnect Speaker leads from Radio. Connect an analog ohmmeter across suspect Speaker terminals. If Speaker pops, Speaker is OK. Remove Radio for Service. If Speaker doesn't pop, repeat procedure at Speaker. If Speaker now pops, check for open or short in Speaker wires.</li> </ul>
<ul style="list-style-type: none"> <li>LCD display is erratic.</li> </ul>	<ul style="list-style-type: none"> <li>Low voltage to Radio.</li> <li>Poor ground connection.</li> </ul>	<ul style="list-style-type: none"> <li>Check 54 (LG/Y) wire for 12 volts. If less than 12 volts, check/charge Battery.</li> <li>Check 694 (R) wire for good continuity to ground.</li> </ul>
<ul style="list-style-type: none"> <li>AM works; FM doesn't work.</li> </ul>	<ul style="list-style-type: none"> <li>Inoperative Radio.</li> </ul>	<ul style="list-style-type: none"> <li>Compare to a known good radio for FM operation. If Radio doesn't work as well, remove Radio for service.</li> </ul>
<ul style="list-style-type: none"> <li>FM works; AM doesn't work.</li> </ul>	<ul style="list-style-type: none"> <li>Inoperative Antenna or Antenna cable.</li> <li>Inoperative Radio.</li> </ul>	<ul style="list-style-type: none"> <li>Check Radio with a test Antenna. If reception improves, check/repair Antenna if necessary. If reception doesn't improve, remove Radio for service.</li> </ul>
<ul style="list-style-type: none"> <li>Tape Deck sounds distorted or doesn't work.</li> </ul>	<ul style="list-style-type: none"> <li>Foreign materials in Tape Deck.</li> <li>Dirty Tape Deck heads.</li> </ul>	<ul style="list-style-type: none"> <li>Remove foreign materials and/or clean Tape Deck heads.</li> </ul>
	<ul style="list-style-type: none"> <li>Ignition circuits.</li> </ul>	<ul style="list-style-type: none"> <li>Check for loose spark plug wire.</li> <li>Check for inoperative spark plug.</li> <li>Move all wiring away from ignition and spark plug wires.</li> </ul>

## BUY IT NOW!

Click Here To Order

# 7-47 TROUBLESHOOTING/DESCRIPTIONS

## SECTION 130 (cont'd)

For further diagnostic information, refer to Sections 15-00, 15-01, 15-02 and 15-03 of the Shop Manual.



**100% SATISFACTION GUARANTEED**

**BUY IT NOW!**

**Click Here To Order**

PayPal American Express Cards DISCOVER AMEXUS MasterCard VISA



# 10-1 GROUNDING

Refer to page 7-1 for Troubleshooting/Descriptions.

## GASOLINE

**BRAKE FLUID LEVEL SWITCH**  
PAGES 42-1, 60-5, 97-2

**WINDSHIELD WIPER MOTOR**  
PAGE 81-1

**ENGINE COMPARTMENT FUSE BOX**

**ENGINE COMPARTMENT LAMP**  
PAGE 92-5

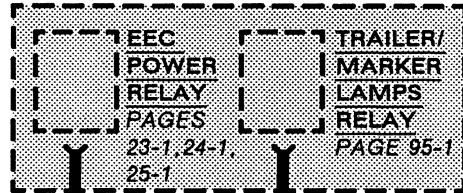

WITH TRAILER TOW

FROM CONNECTOR C101 ON PAGE 10-4

FROM CONNECTOR C103 ON PAGE 10-4

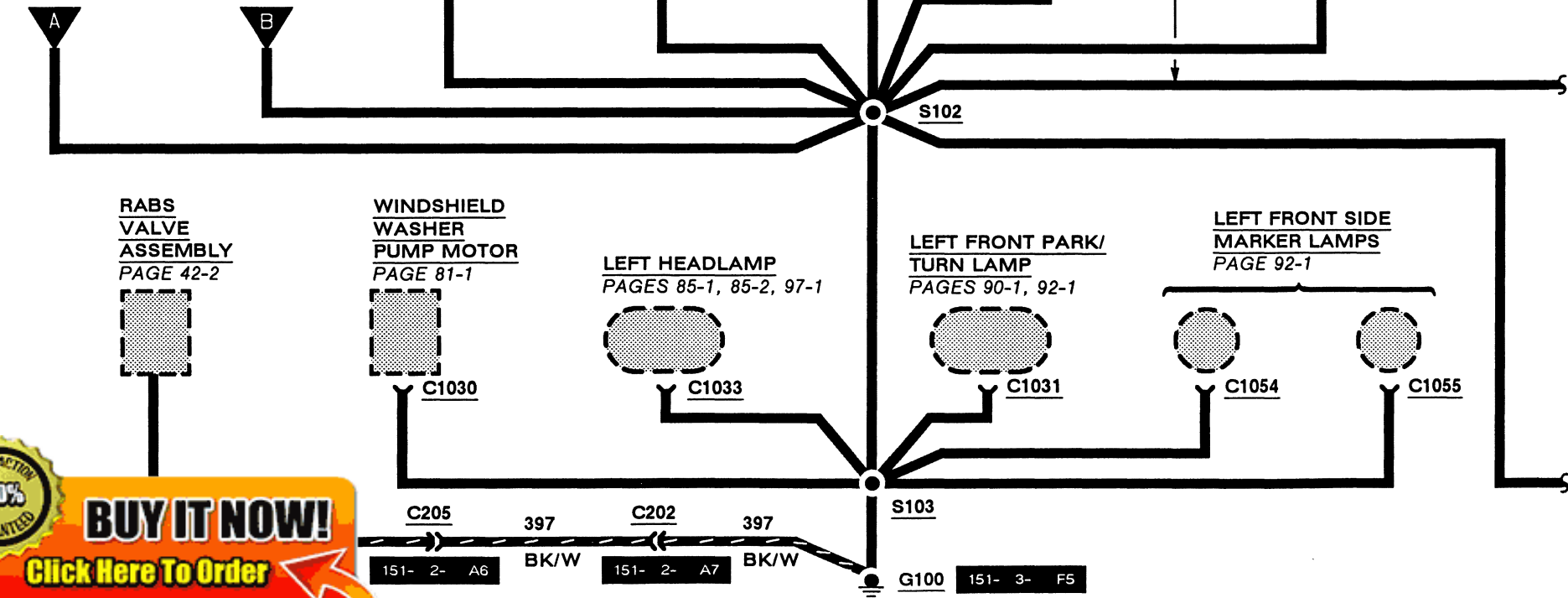

**100% SATISFACTION GUARANTEED**

**BUY IT NOW!**

[Click Here To Order](#)

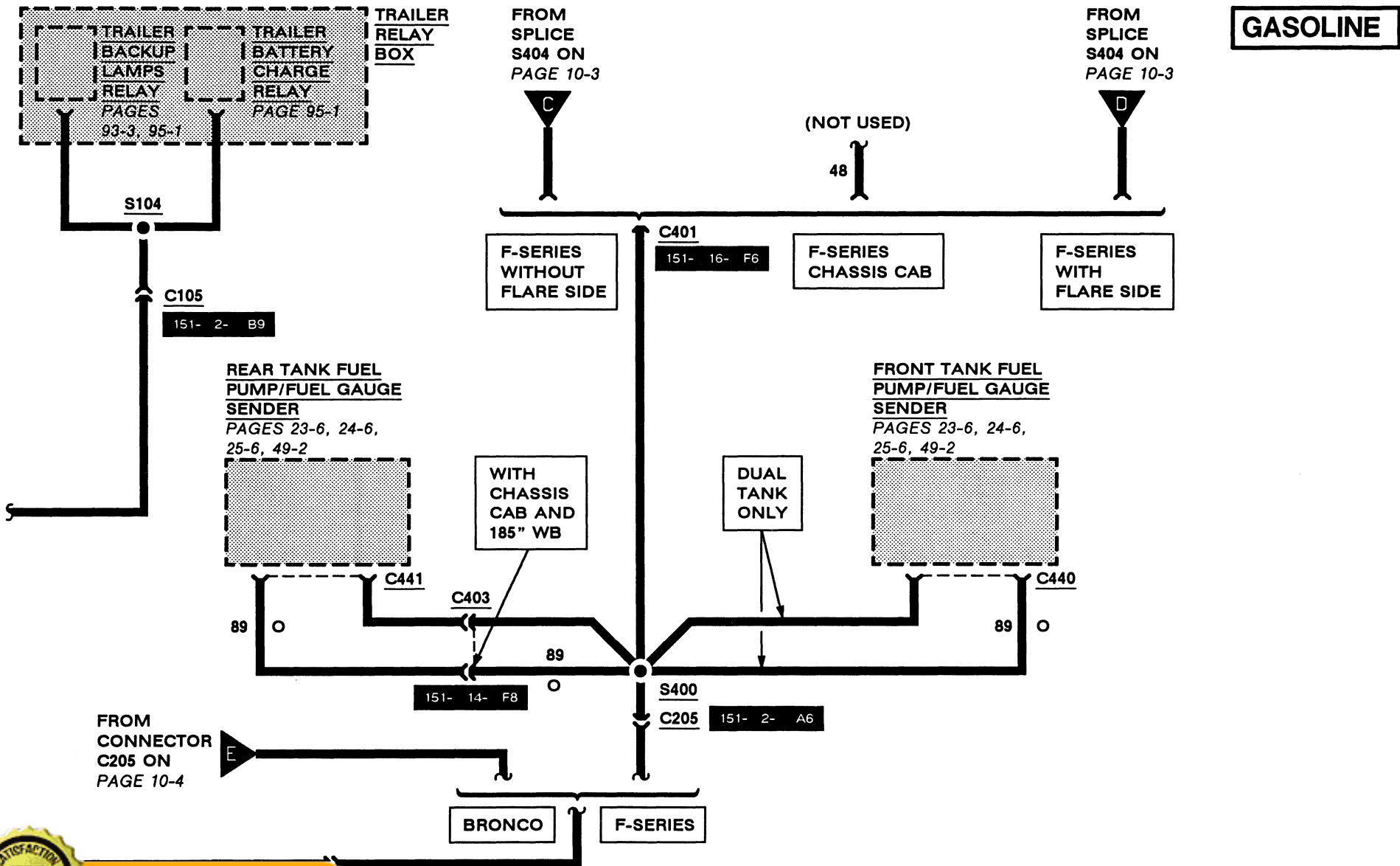

**100% SATISFACTION GUARANTEED**

**BUY IT NOW!**

[Click Here To Order](#)

2- A7

# 10-3 GROUNDS

ALL

**F-SERIES  
WITHOUT  
FLARE SIDE**

**F-SERIES  
WITH  
FLARE SIDE**

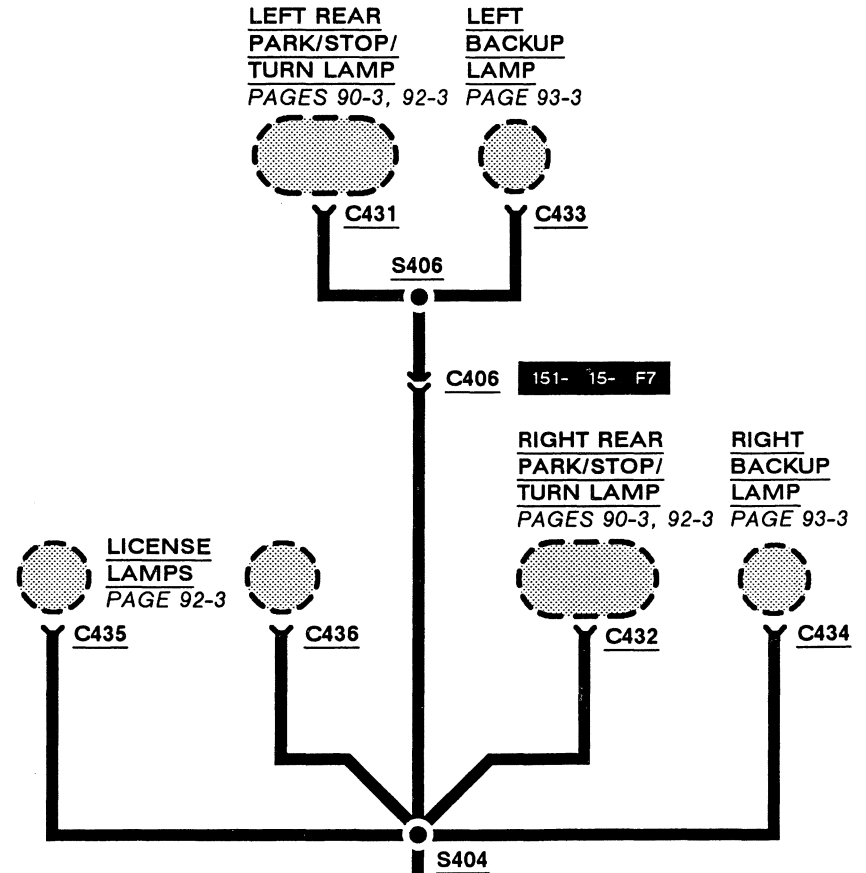
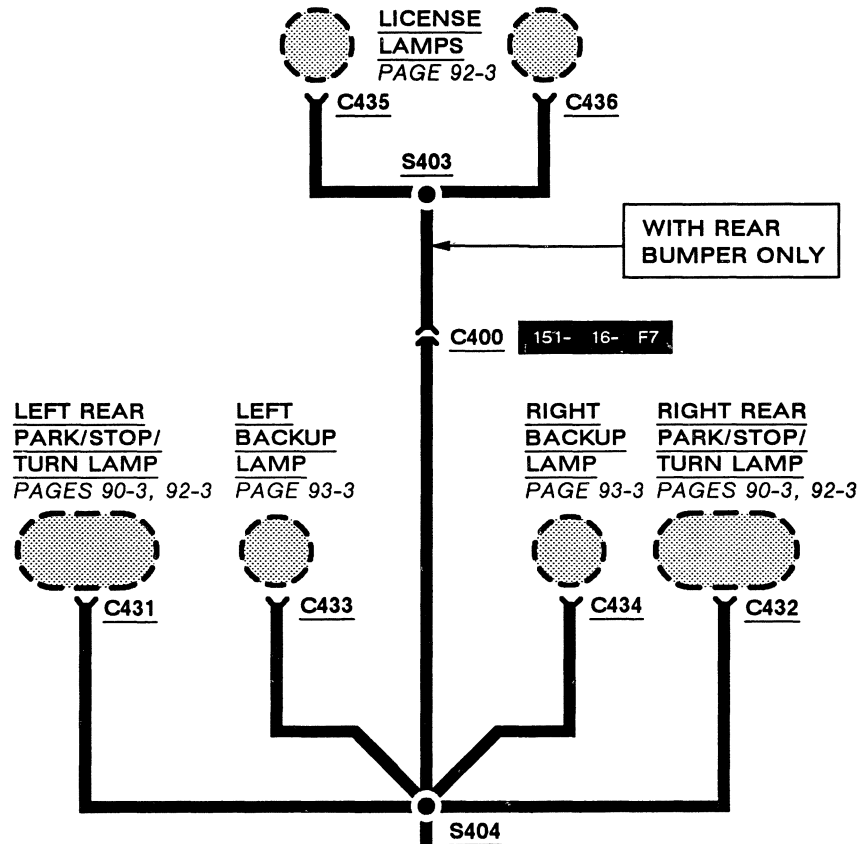

**100% SATISFACTION GUARANTEED**

**BUY IT NOW!**

[Click Here To Order](#)

PayPal, American Express, Discover, MasterCard, VISA

CONNECTOR C401 ON  
PAGE 10-2 (GASOLINE)  
PAGE 10-6 (DIESEL)

TO CONNECTOR C401 ON  
PAGE 10-2 (GASOLINE)  
PAGE 10-6 (DIESEL)

## BRONCO

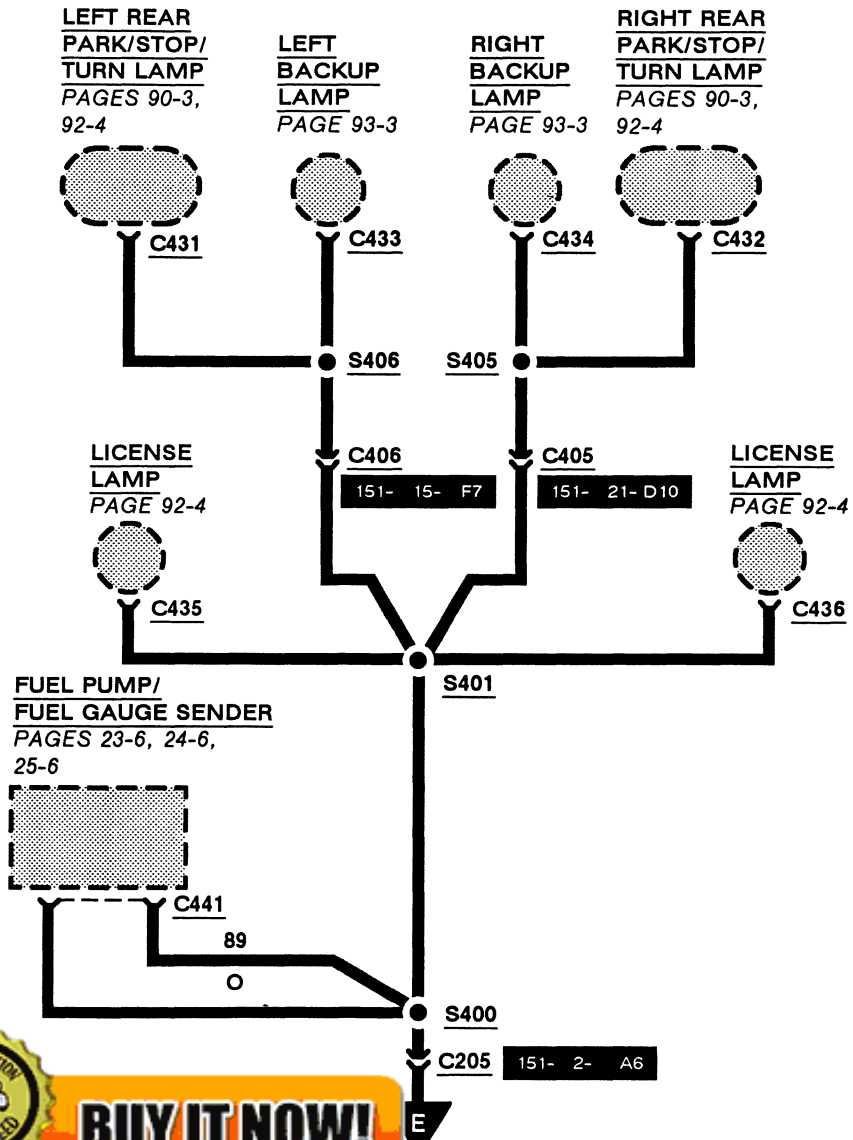

**100% SATISFACTION GUARANTEED**  
**BUY IT NOW!**  
[Click Here To Order](#)

PAYPAL    DISCOVER    MASTERCARD    VISA

CONNECTOR C202 ON

## ALL

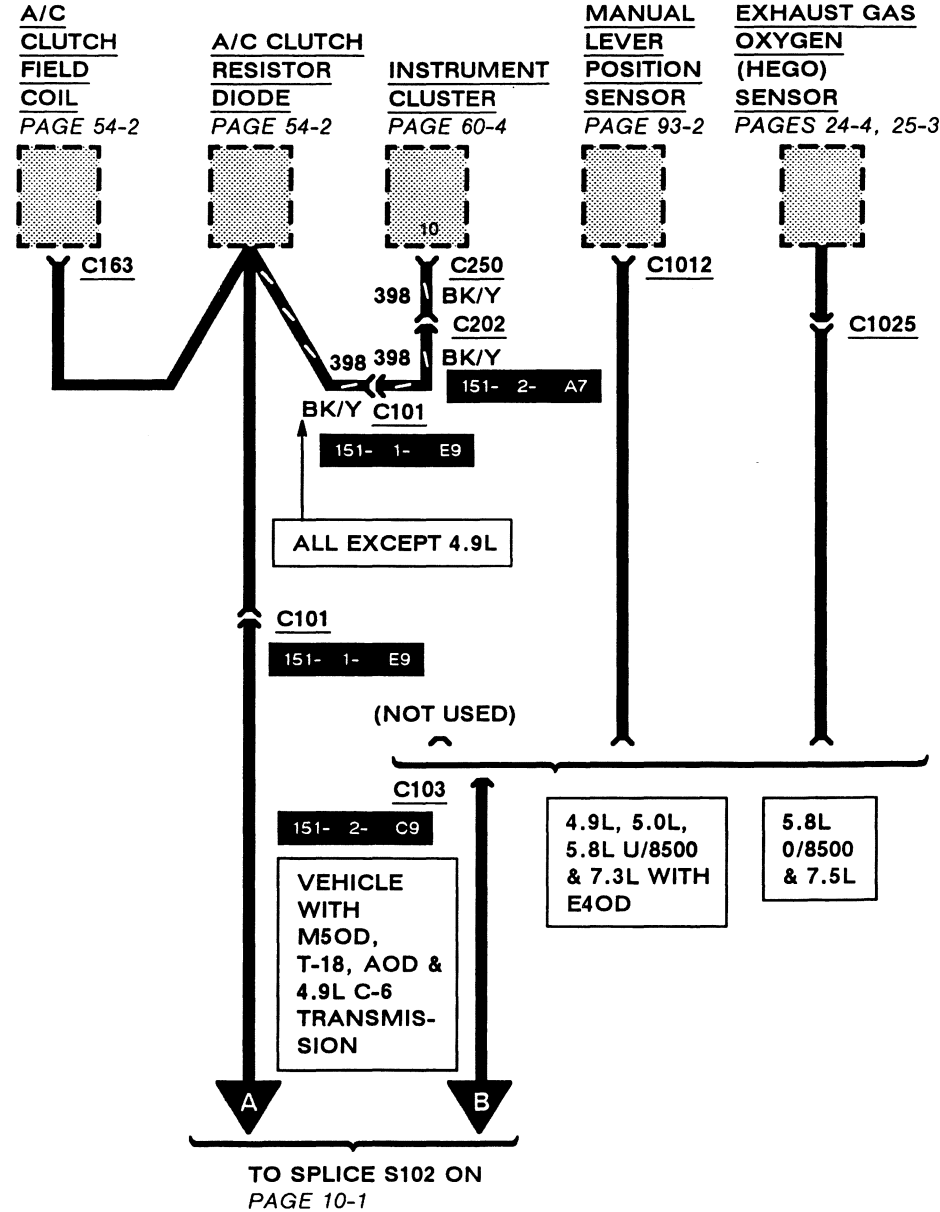

# 10-5 GROUNDS

**DIESEL**

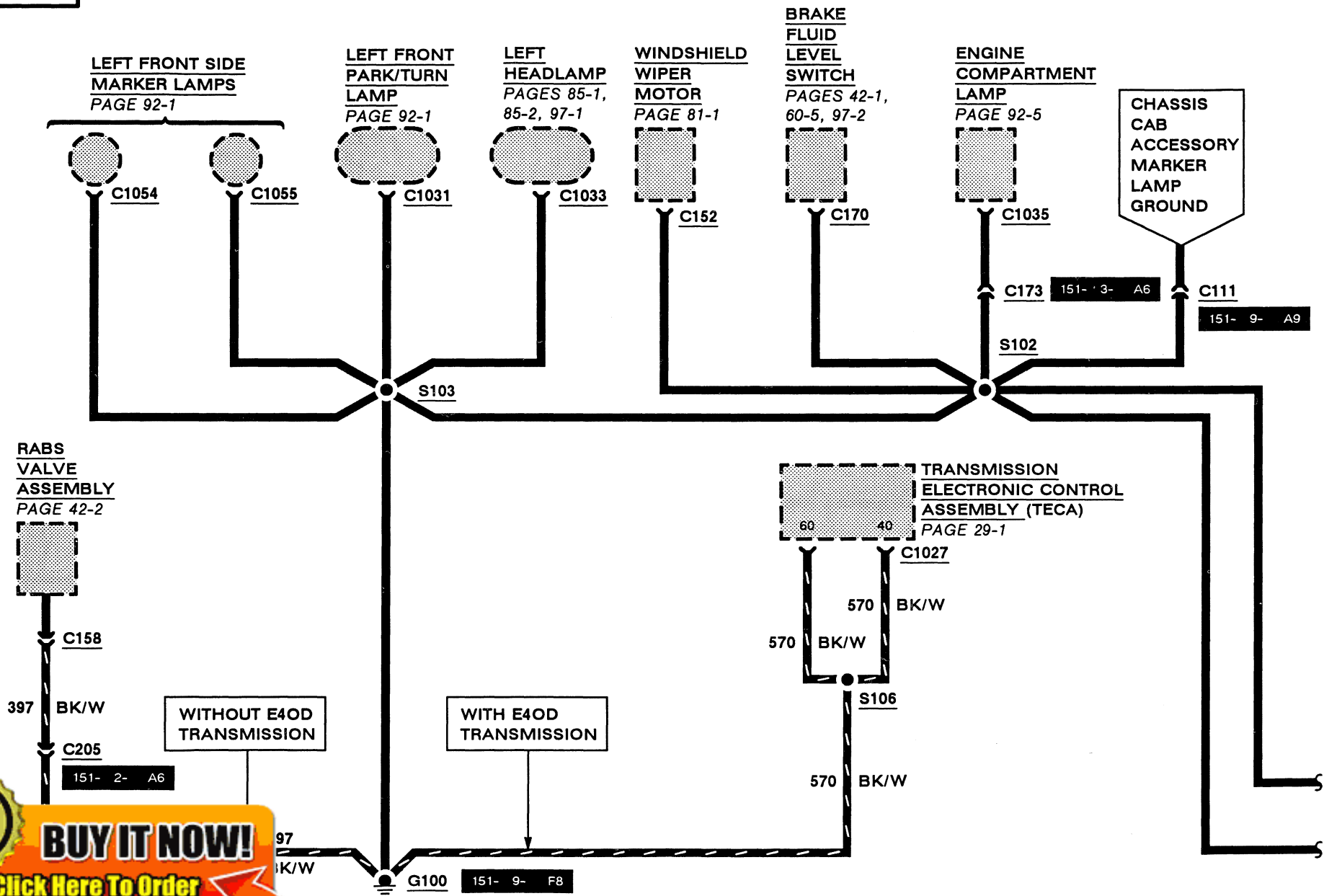

**100% SATISFACTION GUARANTEED**

**BUY IT NOW!**

[Click Here To Order](#)

PayPal   American Express   Discover   MasterCard   VISA

**DIESEL**

**ENGINE COMPARTMENT FUSE BOX**

TECA POWER RELAY PAGE 29-1	TRAILER MARKER LAMPS RELAY PAGE 95-2	TRAILER BACKUP LAMPS RELAY PAGE 95-2	TRAILER BATTERY CHARGE RELAY PAGE 95-2
-------------------------------------	--	--	--

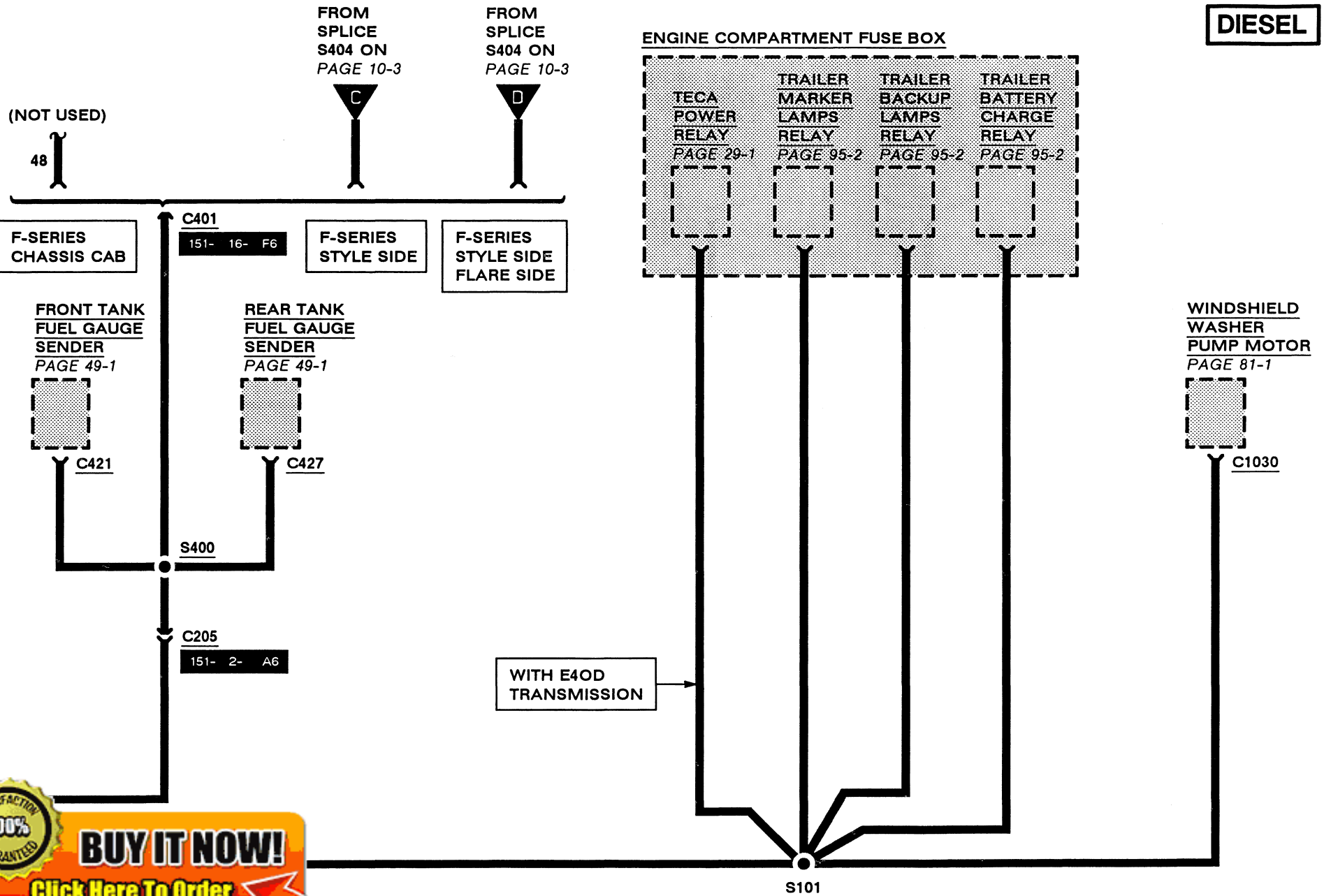

**100% SATISFACTION GUARANTEED**

**BUY IT NOW!**

**Click Here To Order**

# 10-7 GROUNDS

**DIESEL**

LOW VACUUM  
WARNING  
SWITCH  
PAGE 60-5

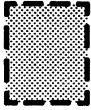

C1010

RIGHT  
HEADLAMP  
PAGES 85-1,  
85-2, 97-1



C1034

RIGHT FRONT  
PARK/TURN  
LAMP  
PAGES 90-1, 92-1



C1032

RIGHT FRONT SIDE  
MARKER LAMPS  
PAGE 92-1



C1053



C1052

RABS VALVE  
ASSEMBLY  
PAGE 42-2

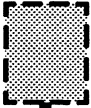

C158

397 BK/W

C205

397 BK/W

C202

WITH E4OD  
TRANSMISSION

397 BK/W

151- 2- A7

G101 (BODY)

151- 9- E1

RIGHT  
BATTERY

G106 (ENGINE)

151- 9- F5

S100

**100% SATISFACTION GUARANTEED**

**BUY IT NOW!**

Click Here To Order

**DIESEL**

A/C CLUTCH  
FIELD COIL  
PAGE 54-3

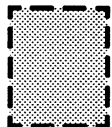

C163

A/C CLUTCH  
RESISTOR DIODE  
PAGE 54-3

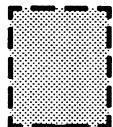

CHARGE INDICATOR  
LAMP RELAY  
PAGE 12-3



C172

A/C CLUTCH  
RESISTOR DIODE  
PAGE 54-3

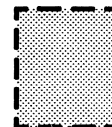

A/C CLUTCH  
FIELD COIL  
PAGE 54-3



C163

AMBULANCE ONLY

C108

151- 9- D1

EXCEPT AMBULANCE

**100% SATISFACTION GUARANTEED**

**BUY IT NOW!**

**Click Here To Order**

PayPal American Express Discover MasterCard VISA

# 10-9 GROUNDS

## GASOLINE

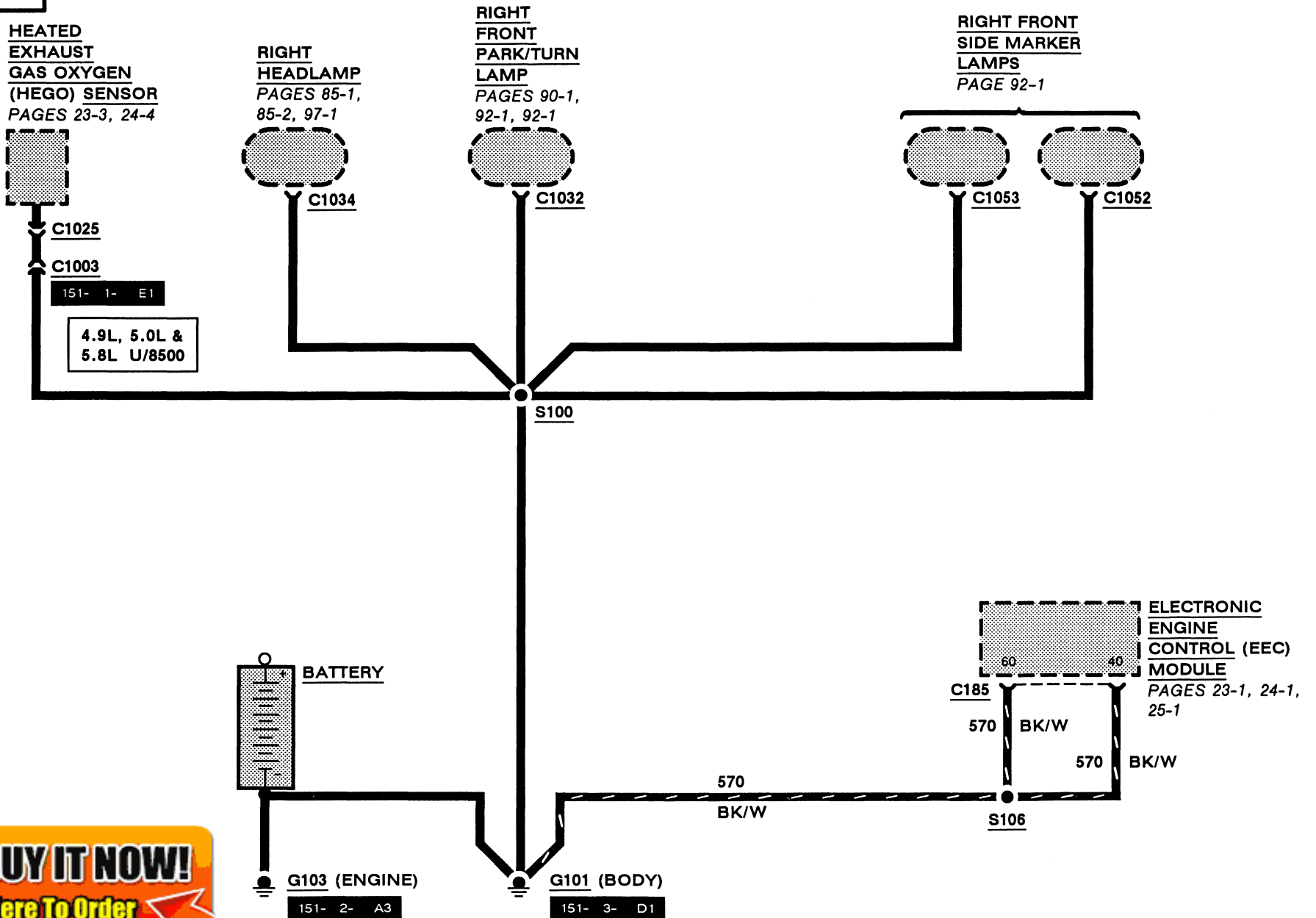

**100% SATISFACTION GUARANTEED**

**BUY IT NOW!**

**Click Here To Order**

PayPal, American Express, Discover, MasterCard, VISA

ALL

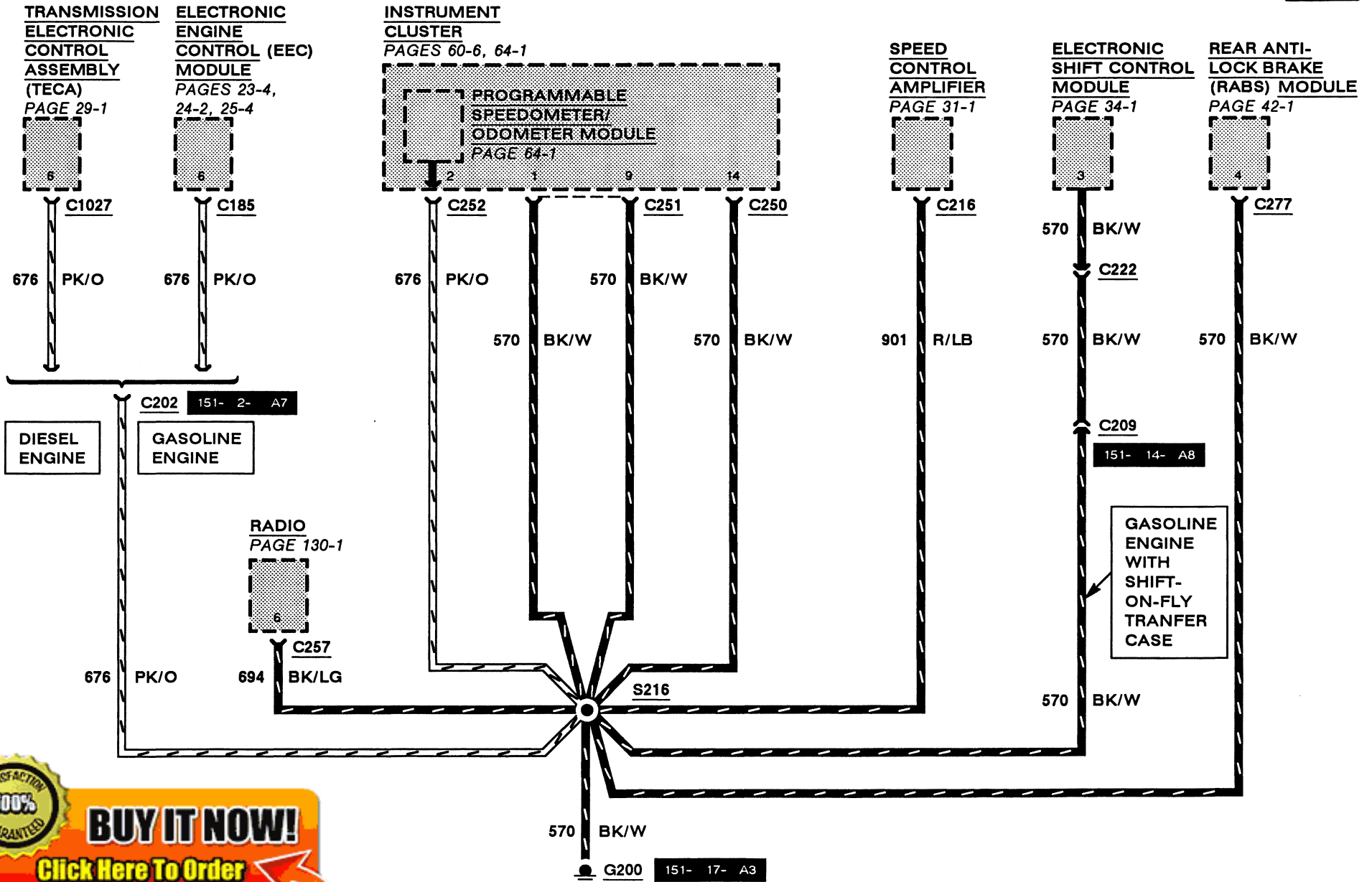

**100% SATISFACTION GUARANTEED**

**BUY IT NOW!**

**Click Here To Order**

# 10-11 GROUNDS

**ALL**

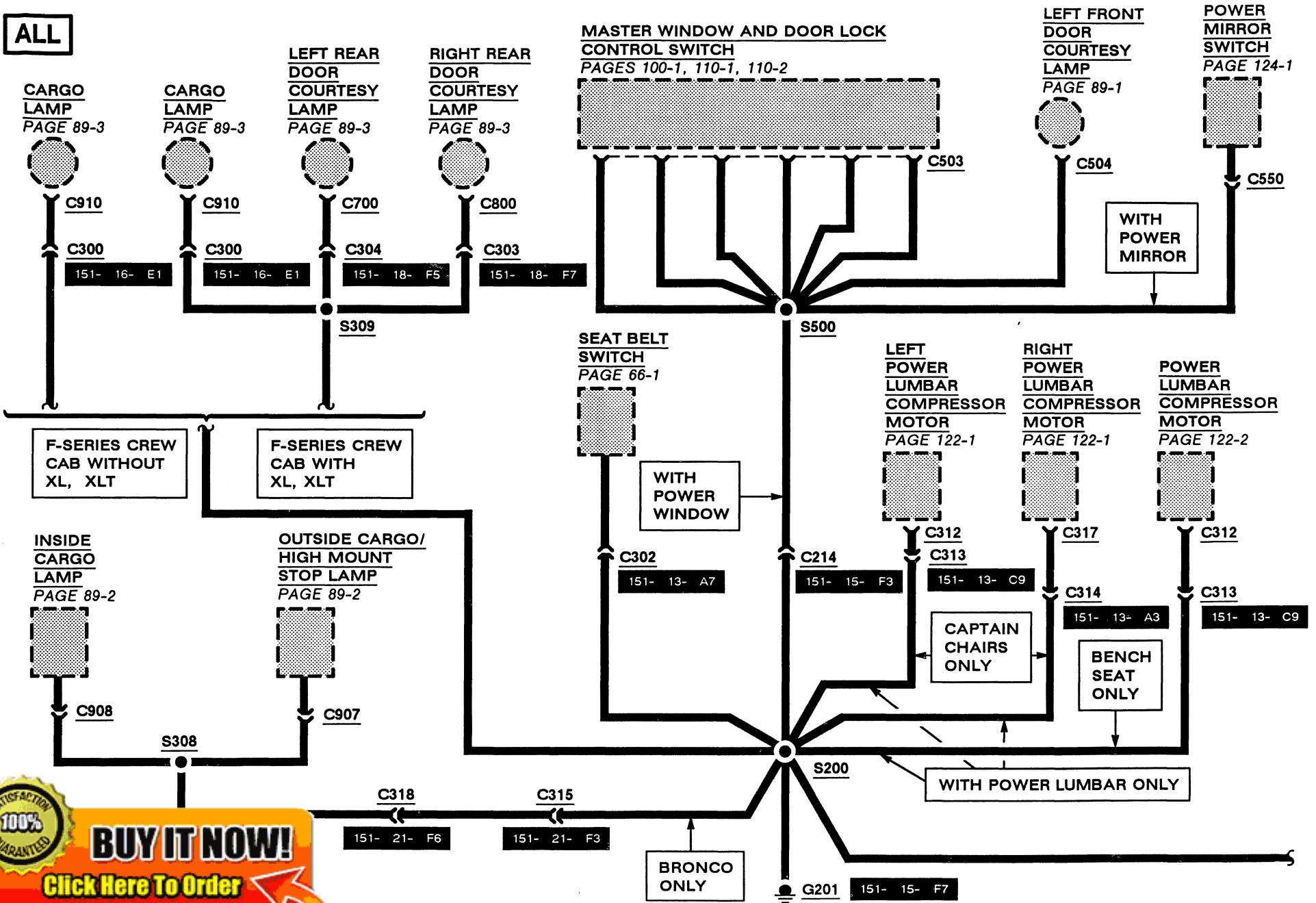

**100% SATISFACTION GUARANTEED**

**BUY IT NOW!**

[Click Here To Order](#)

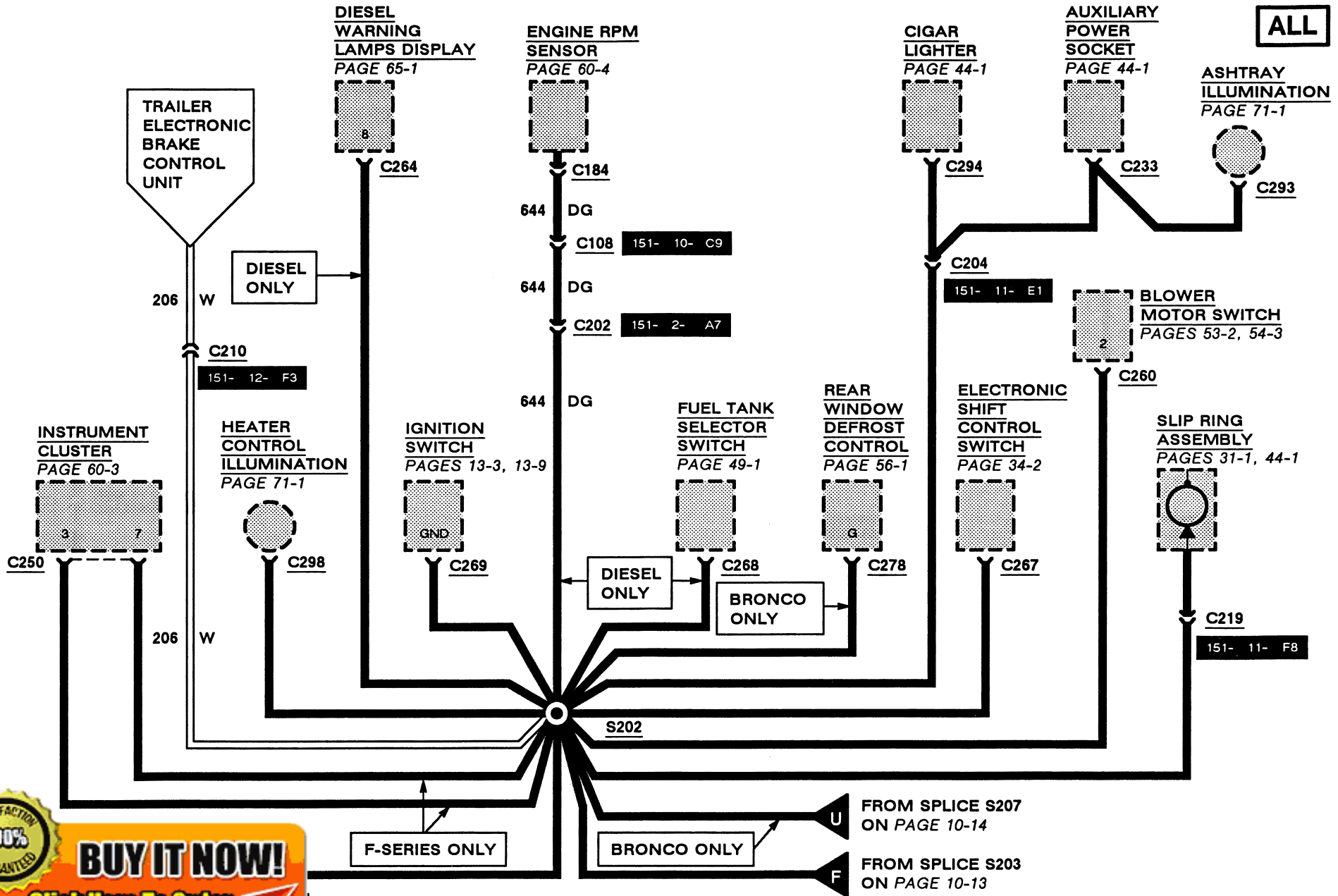

**100% SATISFACTION GUARANTEED**

**BUY IT NOW!**

**Click Here To Order**

PayPal, Discover, MasterCard, VISA

# 152-21 LOCATION INDEX

<u>Connector</u>	<u>Location</u>	<u>Page Zone</u>	<u>Connector Page</u>	<u>Color</u>	<u>Terminal</u>
C153 (7.5L)	RH front of engine, on integral alternator regulator (IAR)	151- 7- F4	150-13	BK	3
C154 (4.9L)	RH front of engine, on integral alternator regulator (IAR)	151- 2- F5	150-13	BK	3
C154 (5.0L)(5.8L)	RH front of engine, on integral alternator regulator (IAR)	151- 5- F5	150-13	BK	3
C154 (7.5L)	RH front of engine, on integral alternator regulator (IAR)	151- 7- F5	150-13	BK	3
C158	On LH frame rail, near RABS valve assembly	151- 14- C1		BK	4
C159 Anti-lock Test Connector	Behind RH side of I/P, near rear anti-lock (RABS) module	151- 12- C1		BK	1
C161 (AOD Transmission)	Front of transfer case, near 4x4 hi/low indicator switch	151- 14- B9		BK	2
C161 (Borg-Warner T-18 Transmission)	Front of transfer case, near 4x4 hi/low indicator switch	151- 17-B10		BK	2
C161 (C6 Transmission)	Front of transfer case, near 4x4 hi/low indicator switch	151- 14- F2		BK	2
C161 (E4OD Transmission)	Front of transfer case, near 4x4 hi/low indicator switch	151- 14- D1		BK	2
C161 (Mazda M5OD Transmission)	Front of transfer case, near 4x4 hi/low indicator switch	151- 17- D1		BK	2
C161 (S5-42 ZF Transmission)	Front of transfer case, near 4x4 hi/low indicator switch	151- 17- F3		BK	2
C162 (4.9L)	RH rear of engine compartment, on A/C clutch cycling pressure switch	151- 3- A3		GY	3
C162 (5.0L)(5.8L)	RH rear of engine compartment, on A/C clutch cycling pressure switch	151- 5- A1		GY	3
C162 (7.3L)	RH rear of engine compartment, on A/C clutch cycling pressure switch	151- 9- A2		GY	3
C162 (7.5L)	RH rear of engine compartment, on A/C clutch cycling pressure switch	151- 7- A3		GY	3
C163 (4.9L)	LH front of engine, on A/C clutch field coil	151- 3- F4		BK	2
C163 (5.0L)(5.8L)	LH front of engine, on A/C clutch field coil	151- 5- F5		BK	2
C163 (7.3L)	LH front of engine, on A/C clutch field coil	151- 9- D9		BK	2
C163 (7.5L)	LH front of engine, on A/C clutch field coil	151- 7- F5		BK	2
C164 (4.9L)	RH front of engine, on air charge temperature (ACT) sensor	151- 1- F4		BK	2
C164 (5.0L)(5.8L)	Top center front of engine, on air charge temperature (ACT) sensor	151- 4- D9		BK	2
C164 (7.5L)	Top center of engine, on air charge temperature (ACT) sensor	151- 6- F4		BK	2
	Top RH front of engine, on alternator	151- 9- F6		BK	2
	Top of transmission, on backup lamp switch	151- 17-A10		BK	2
	Top LH side of transmission, on backup Lamp Switch	151- 17- B1		BK	2
	Top LH side of transmission, on backup lamp switch	151- 17- E1		BK	2

**100% SATISFACTION GUARANTEED**

**BUY IT NOW!**

**Click Here To Order**

PayPal American Express Discover MasterCard VISA

# LOCATION INDEX 152-22

<u>Connector</u>	<u>Location</u>	<u>Page Zone</u>	<u>Connector Page</u>	<u>Color</u>	<u>Terminal</u>
C167	LH side of transmission, on backup/neutral safety switch	151- 14- A9	.. 150- 1	BK	5
C168 (4.9L)	RH side of safety wall, near blower motor	151- 3- C1		BK	2
C168 (5.0L)(5.8L)	RH side of safety wall, near blower motor	151- 5- B1		BK	2
C168 (7.3L)	RH side of safety wall, near blower motor	151- 9- B1		BK	2
C169 (4.9L)	RH side of safety wall, on blower motor resistor	151- 3- B1		W	4
C169 (5.0L)(5.8L)	RH side of safety wall, on blower motor resistor	151- 5- A2		W	4
C169 (7.3L)	RH side of safety wall, on blower motor resistor	151- 9- B1		W	4
C169 (7.5L)	RH side of safety wall, on blower motor resistor	151- 7- A1		W	4
C170 (4.9L)	LH rear of engine compartment, on brake fluid level switch	151- 3- A8		GY	3
C170 (5.0L)(5.8L)	LH rear of engine compartment, on brake fluid level switch	151- 5- A8		GY	3
C170 (7.3L)	LH rear of engine compartment, on brake fluid level switch	151- 9- A4		GY	3
C170 (7.5L)	LH rear of engine compartment, on brake fluid level switch	151- 7- A9		GY	3
C171 (4.9L)	Lower RH side of engine compartment, on canister purge solenoid	151- 1- F3		BK	2
C171 (5.0L)(5.8L)	RH front of engine, on canister purge solenoid	151- 4- F4		BK	2
C171 (7.5L)	RH side of engine, on canister purge solenoid	151- 6- B1		BK	2
C172	RH side of engine compartment, on charge indicator lamp relay	151-10- F7		BK	4
C173	LH rear of engine compartment, near hood hinge	151- 3- A6		BK	4
C174	Top center front of engine, on cold idle solenoid	151- 8- F5			1
C175	Top center front of engine, on cold timing advance solenoid	151- 8- F7			1
C177 (Without DRL)	Front LH side of lower radiator support, on daytime running lamps (DRL) jumper	151- 3- F8	.. 150- 2	BK	8
C177 (With DRL)	Front LH side of lower radiator support, on daytime running lamps (DRL) module	151- 3- D9	.. 150- 2	BK	8
C178 (4.9L)	LH front of engine, near distributor	151- 2- E9	.. 150- 2		8
C178 (5.0L)(5.8L)	Top center front of engine, near distributor	151- 4- F8	.. 150- 2		8
C178 (7.5L)	Top LH front of engine, to distributor	151- 6- F7			8
C180 (4.9L)	LH rear of engine, on EGR control solenoid	151- 1- D9		BK	2
C180 (5.0L)(5.8L)	Top LH side of engine, on EGR control solenoid	151- 4- A6		BK	2
	LH side of engine compartment, on EGR vacuum regulator (EVR) solenoid	151- 6- E9		BK	2
	Top LH rear of engine, on EGR valve position (EVP) sensor	151- 1- A1		BK	4
	Top RH front of engine, on EGR valve position (EVP) sensor	151- 4- D1		BK	4

**100% SATISFACTION GUARANTEED**

**BUY IT NOW!**

**Click Here To Order**

PayPal American Express Discover MasterCard VISA

# 152-23 LOCATION INDEX

<u>Connector</u>	<u>Location</u>	<u>Page Zone</u>	<u>Connector Page</u>	<u>Color</u>	<u>Terminal</u>
C182 (7.5L)	LH rear of engine, on EGR valve position (EVP) sensor	151- 6- A5		BK	4
C183 (4.9L)	Center front of engine, on engine coolant temperature (ECT) sensor	151- 1- F5		BR	2
C183 (5.0L)(5.8L)	Center front of engine, on engine coolant temperature (ECT) sensor	151- 4- F5		BR	2
C183 (7.5L)	LH front of engine, on engine coolant temperature (ECT) sensor	151- 6- F5		BR	2
C184	Top LH front of engine, to engine RPM sensor	151- 8- F6		BK	2
C185 (4.9L)	LH side of safety wall, on electronic engine control (EEC) module	151- 1- A8	150- 3	GY	60
C185 (5.0L)(5.8L)	LH side of safety wall, on electronic engine control (EEC) module	151- 4- A9	150- 3	GY	60
C185 (7.5L)	LH side of safety wall, on electronic engine control (EEC) module	151- 6- A8	150- 5	GY	60
C186	Top RH front of engine, on engine temperature switch	151- 8- F4			2
C187	Top LH front of engine, on fuel injection pump lever (FIPL) sensor	151- 8-D10		BK	3
C188	RH side of engine, on fuel heater	151- 8- B1			1
C190 (4.9L)	Top RH front of engine, on fuel injector #1	151- 2- B1		BK	2
C190 (5.0L)(5.8L)	Top RH front of engine, on fuel injector #1	151- 4- F7		BK	2
C190 (7.5L)	Top RH front of engine, on fuel injector #1	151- 6- E1		BK	2
C191 (4.9L)	Top RH front of engine, on fuel injector #2	151- 2- B1		BK	2
C191 (5.0L)(5.8L)	Top RH side of engine, on fuel injector #2	151- 4- F7		BK	2
C191 (7.5L)	Top RH side of engine, on fuel injector #2	151- 6- E1		BK	2
C192 (4.9L)	Top RH side of engine, on fuel injector #3	151- 2- B1		BK	2
C192 (5.0L)(5.8L)	Top RH side of engine, on fuel injector #3	151- 4- F7		BK	2
C192 (7.5L)	Top RH side of engine, on fuel injector #3	151- 6- E1		BK	2
C193 (4.9L)	Top RH rear of engine, on fuel injector #4	151- 2- B1		BK	2
C193 (5.0L)(5.8L)	Top RH rear of engine, on fuel injector #4	151- 4- F7		BK	2
C193 (7.5L)	Top RH rear of engine, on fuel injector #4	151- 6- E1		BK	2
C194 (4.9L)	Top RH rear of engine, on fuel injector #5	151- 2- B1		BK	2
C194 (5.0L)(5.8L)	Top LH front of engine, on fuel injector #5	151- 4- F7		BK	2
C194 (7.5L)	Top LH front of engine, on fuel injector #5	151- 6- E1		BK	2

**100% SATISFACTION GUARANTEED**

**BUY IT NOW!**

**Click Here To Order**

PayPal   Discover   MasterCard   VISA

<u>Connector</u>	<u>Location</u>	<u>Page Zone</u>	<u>Connector Page</u>	<u>Color</u>	<u>Terminal</u>
C195 (4.9L)	Top RH rear of engine, on fuel injector #6	151- 2- B1		BK	2
C195 (5.0L) (5.8L)	Top LH side of engine, on fuel injector #6	151- 4- F7		BK	2
C195 (7.5L)	Top LH side of engine, on fuel injector #6	151- 6- E1		BK	2
C196 (5.0L) (5.8L)	Top RH side of engine, on fuel injector #7	151- 4- F7		BK	2
C196 (7.5L)	Top LH side of engine, on fuel injector #7	151- 6- E1		BK	2
C197 (5.0L) (5.8L)	Top RH rear of engine, on fuel injector #8	151- 4- F7		BK	2
C197 (7.5L)	Top LH rear of engine, on fuel injector #8	151- 6- E1		BK	2
C198 VIP Test Connector (4.9L)	LH rear of engine compartment, on bracket	151- 1- A9	.. 150-22	GY	6
C198 VIP Test Connector (5.0L) (5.8L)	LH rear of engine compartment, on bracket	151- 4- B9	.. 150-22	GY	6
C198 VIP Test Connector (7.3L)	LH rear of engine compartment, on bracket	151- 8-B10	.. 150-22	GY	6
C198 VIP Test Connector (7.5L)	LH rear of engine compartment, on bracket	151- 6- B9	.. 150-22	GY	6
C199 VIP Test Connector (4.9L)	LH rear of engine compartment, on bracket	151- 1- A9	.. 150-22	GY	1
C199 VIP Test Connector (5.0L) (5.8L)	LH rear of engine compartment, on bracket	151- 4- B9	.. 150-22	GY	1
C199 VIP Test Connector (7.3L)	LH rear of engine compartment, on bracket	151- 8-B10	.. 150-22	GY	1
C199 VIP Test Connector (7.5L)	LH rear of engine compartment, on bracket	151- 6- B9	.. 150-22	GY	1
C200	Behind LH cowl panel	151- 15- A5		GY	8
C201	Behind RH cowl panel	151- 15- F7		GY	2
C202	LH rear of engine compartment, in safety wall	151- 2- A7			76
C203	Behind RH cowl panel	151- 15- A7		BR	6
C204	Behind lower center of I/P, near RH side of ashtray assembly	151- 11- E1		BK	4
C205	LH rear of engine compartment, in safety wall	151- 2- A6			24
C207	Behind lower LH side of I/P, on fuse panel	151- 11- D9		W	1
C209	Behind RH cowl panel	151- 14- A8		BK	12
C210	Behind lower center of I/P	151- 12- F3		GY	4
C213	Behind RH cowl panel	151- 15- F6		GR	8
C214	Behind LH cowl panel	151- 15- F3		GY	8
C216	Behind lower center of I/P, on speed control amplifier	151- 11- F4	.. 150-18	GY	6
C217	Behind lower center of I/P, on speed control amplifier	151- 11- F4	.. 150 -1	W	8
	RH side of steering column, to slip ring assembly and ignition key warning switch	151- 11- F8		GY	4
	Below center of vehicle, near transfer case assembly	151- 14- F4	.. 150-19	BK	10
	Behind RH cowl panel, on electronic shift control module	151- 14- A8	.. 150- 7	W	8
	Behind RH cowl panel, near electronic shift control module	151- 14- A9	.. 150- 7	GY	8



## BUY IT NOW!

Click Here To Order







# 152-25 LOCATION INDEX

<u>Connector</u>	<u>Location</u>	<u>Page Zone</u>	<u>Connector Page</u>	<u>Color</u>	<u>Terminal</u>
C223	Behind RH cowl panel, on electronic shift control module	151- 14- A8	150- 7	BR	5
C224	Behind RH side of I/P, on interval governor	151- 12- A2	150-10		14
C228	Behind RH cowl panel	151- 15- A8		GY	8
C229	Behind LH cowl panel	151- 15- F2		GY	8
C230	Top of steering column, on multi-function switch	151- 12- B9	150-15		7
C231	Top of steering column, on multi-function switch	151- 12- B9	150-15	GY	10
<b>C232 Enable PSOM Programming</b>					
Connector	Behind lower RH side of I/P, below glove compartment	151- 11- D1		BR	1
C233	Behind lower center of I/P, on auxiliary power socket	151- 11- F2			1
C234	Behind LH cowl panel	151- 19- A1		BR	6
C235	Behind lower center of I/P, on auxiliary power socket	151- 11- F2		BK	1
C250 (Diesel Engine)	Behind top LH side of I/P, on instrument cluster	151- 11- A7	150-12	BK	14
C250 (Gasoline Engines)	Behind top LH side of I/P, on instrument cluster	151- 11- A7	150-11	BK	14
C251 (Diesel Engine)	Behind top LH side of I/P, on instrument cluster	151- 11- A7	150-12	GY	14
C251 (Gasoline Engines)	Behind top LH side of I/P, on instrument cluster	151- 11- A7	150-11	GY	14
C252 (Diesel Engine)	Behind top LH side of I/P, on instrument cluster	151- 11- A7	150-13	BK	12
C252 (Gasoline Engines)	Behind top LH side of I/P, on instrument cluster	151- 11- A7	150-13	BK	12
C257	Behind top center of I/P, on radio	151- 12- A6	150-16	BK	8
C258	Behind top center of I/P, on radio	151- 12- A6	150-16	BK	8
C260	Behind center of I/P, on blower motor switch	151- 11- A4		GY	4
C261 (Automatic)	Behind LH side of I/P, on clutch interlock switch jumper	151- 12- F5	150- 1	BK	6
C261 (Manual)	Behind LH side of I/P, on clutch interlock switch	151- 12- F5	150- 1	BK	6
C262	In front of RH front door jamb, on right front courtesy lamp switch	151- 16- B1		N	3
C263	In lower rear of LH front door jamb, on left front courtesy lamp switch	151- 16- D1		GY	3
C264	Behind top LH side of I/P, on diesel warning lamps display	151- 11- A6		BK	8
C267	Behind top LH side of I/P, on electronic shift control switch	151- 12- A7	150- 8	GY	8
	Behind top LH side of I/P, on fuel tank selector switch	151- 12- F9	150- 9	GY	6
	Top RH side of steering column, on ignition switch	151- 12- A8	150-10		15
	Behind RH cowl panel, on inertia switch	151- 14- A7		GY	3
	Behind top LH side of I/P, on main light switch	151- 12- D9	150-14	GY	9
	Behind top LH side of I/P, on master tailgate window switch	151- 12- E9	150-14	GY	5

**100% SATISFACTION GUARANTEED**

**BUY IT NOW!**

**Click Here To Order**

PayPal American Express Cards Discover MasterCard VISA

# LOCATION INDEX 152-26

<u>Connector</u>	<u>Location</u>	<u>Page Zone</u>	<u>Connector Page</u>	<u>Color</u>	<u>Terminal</u>
C275	Top of steering column, near overdrive cancel switch	151- 12-	C9		3
C276	Behind LH side of I/P, on park brake switch	151- 11-	E9	BK	1
C277	Behind RH side of I/P, on rear anti-lock brake (RABS) module	151- 12-	E1	.. 150-17	BK 14
C278	Behind top LH side of I/P, on rear window defrost control	151- 11-	A5	.. 150-17	N 5
C279	Behind LH side of I/P, on stop lamp switch	151- 12-	F6		BK 2
C280	Behind lower center of I/P, on warning chime module	151- 11-	C1	.. 150-22	GY 7
C282	In center of steering wheel, to speed control switch	151- 11-	B9		
C283	In steering wheel, on horn switch	151- 11-	A9		
C292	Behind RH side of I/P, on glove compartment lamp	151- 11-	B1	BR	2
C293	Behind lower center of I/P, on ashtray illumination	151- 11-	F3	BK	2
C294	Behind lower center of I/P, on cigar lighter	151- 11-	E1		1
C295	Behind lower center of I/P, on cigar lighter	151- 11-	E1	BK	1
C296 (With A/C)	Behind center of I/P, on A/C-heater control assembly	151- 11-	A2	W	4
C296 (Without A/C)	Behind center of I/P, on heater control assembly	151- 11-	A2	W	4
C298	Behind center of I/P, on heater control illumination	151- 11-	A3	BK	2
C300	At base of LH "B" pillar	151- 16-	E1	GY	4
C302	Below RH side of LH front seat, to seat belt switch	151- 13-	A7	GY	2
C303	At base of RH "B" pillar	151- 18-	F7	GY	4
C304	At base of LH "B" pillar	151- 18-	F5	GY	4
C305	Under LH side of LH front seat, to left power lumbar switch	151- 13-	E9	GY	2
C306	Under RH side of RH front seat, to right power lumbar switch	151- 13-	D1	GY	2
C310	LH side of tailgate, near rear window, on rear window defrost grid	151- 20-	A7	BK	1
C311	Center of tailgate, near rear window, on rear window defrost grid	151- 20-	A7	BK	1
C312 (With Captain Chairs)	Under front of LH front seat, on left power lumbar motor	151- 13-	F6	BK	2
C312 (Without Captain Chairs)	Under front of front seat, on power lumbar motor	*		BK	2
C313	Below LH front seat	151- 13-	C9	GY	2
	Below RH front seat	151- 13-	A3	GY	2
	At base of LH "B" pillar	151- 21-	F3	BR	6
	Under front of RH front seat, on right power lumbar motor	151- 13-	F3	BK	2
	LH rear of cargo area, near center of "D" pillar	151- 21-	F6	BR	6

**100% SATISFACTION GUARANTEED**

**BUY IT NOW!**

**Click Here To Order**

PayPal American Express Discover MasterCard VISA

# 152-27 LOCATION INDEX

<u>Connector</u>	<u>Location</u>	<u>Page Zone</u>	<u>Connector Page</u>	<u>Color</u>	<u>Terminal</u>
C320	In center of roof	151- 19- A6		BK	2
C321	In front of LH rear door jamb, on left rear courtesy lamp switch	151- 19- D1		N	3
C322	In front of RH rear door jamb, or right rear courtesy lamp switch	151- 19- A8		N	3
C326 (Bronco)	LH side of cargo area, on left rear speaker	151- 21- A4		GY	2
C326 (F-Series)	LH rear of cab, on left rear speaker	151- 15- A6		GY	2
C327 (Bronco)	RH side of cargo area, on right rear speaker	151- 21-B10		GY	2
C327 (F-Series)	RH rear of cab, on right rear speaker	151- 15- E9		GY	2
C400	Under center rear of vehicle, near rear crossmember	151- 16- F7		GY	4
C401	Under LH rear of vehicle, near rear crossmember	151- 16- F6		GY	8
C403	Below LH rear of vehicle, forward of rear fuel tank	151- 14- F8		BK	4
C405	Under LH rear of vehicle, on frame rail, near fuel tank	151- 21-D10		GY	4
C406	Under LH rear of vehicle, near rear crossmember	151- 15- F7		GY	4
C407	Under center rear of vehicle, near rear crossmember	151- 16- F8			4
C408	Under RH rear corner of vehicle	151- 16- E9		BK	4
C409	Under LH rear corner of vehicle	151- 16- F6		BK	4
C410	Under center rear of vehicle, near rear body marker lamps	151- 16- B9		BK	4
C411	In LH rear quarter panel, forward of wheel well, to left rear side body marker lamp	151- 19- F4		BK	4
C412	In LH rear quarter panel, behind wheel well, to left rear side body marker lamp	151- 19- F4		BK	4
C413	In RH rear quarter panel, forward of wheel well, to right rear side body marker lamp	151- 19- B9		BK	4
C417	Under center rear of vehicle, near rear crossmember	151- 16- F9			8
C418	Under LH rear of vehicle, near rear lamp assembly	151- 21- F7		N	4
C420	In RH rear quarter panel, behind wheel well, to right rear side body marker lamp	151- 19- B9		BK	4
C421	Top RH side of front fuel tank, on front tank fuel gauge sender	151- 14- F6		GY	2
C423	Under LH side of vehicle, at frame rail, on fuel tank selector valve	151- 14- F5	150- 9	GY	6
	Under center rear of vehicle, near rear crossmember	151- 16- G8		GY	4
	Top RH side of rear fuel tank, on rear tank fuel gauge sender	151- 14- E9		GY	2
	In LH side of tailgate, on tailgate latch switch	151- 20-E10		BK	2
	In lower center of tailgate, to tailgate power window motor	151- 20-D10		GY	2

**100% SATISFACTION GUARANTEED**

**BUY IT NOW!**

**Click Here To Order**

PayPal American Express Discover MasterCard VISA

<u>Connector</u>	<u>Location</u>	<u>Page Zone</u>	<u>Connector Page</u>	<u>Color</u>	<u>Terminal</u>
C431 (With Chassis Cab)	LH rear of vehicle, on left rear park/stop/turn lamp	151- 16- F3		BK	2
C431 (Without Chassis Cab)	LH rear of vehicle, on left rear park/stop/turn lamp	151- 16- F3		BK	3
C432 (With Chassis Cab)	RH rear of vehicle, on right rear park/stop/turn lamp	151- 16- C9		BK	2
C432 (Without Chassis Cab)	RH rear of vehicle, on right rear park/stop/turn lamp	151- 16- C9		BK	3
C433	LH rear of vehicle, on left backup lamp	151- 16- F4		BK	2
C434	RH rear of vehicle, on right backup lamp	151- 16- D9		BK	2
C435	Center rear of vehicle, on license lamp	151- 16- E9		BK	2
C436	Center rear of vehicle, on license lamp	151- 16- E9		BK	2
C440	Top RH side of front fuel tank, on front tank fuel pump/fuel gauge sender	151- 14- F6		BK	4
C441 (Bronco)	Top RH side of fuel tank, on fuel pump/fuel gauge sender	151- 20-C10		BK	4
C441 (F-Series) (All Except Chassis Cab And 185" Wheel Base)	Top RH side of rear fuel tank, on rear tank fuel pump/fuel gauge sender	151- 14- D9		BK	4
C441 (F-Series) (Chassis Cab And 185" Wheel Base)	Top RH side of rear fuel tank, on rear tank fuel pump/fuel gauge sender	151- 14- C9		BK	4
C444	Below rear of vehicle, on differential speed sensor (DSS)	151- 14- F9		BK	2
C446	Lower rear of vehicle, near license plate, on license lamp	*		BK	1
C447	LH rear of vehicle, on left backup lamp	151- 16- F4		BK	1
C448	RH rear of vehicle, on right backup lamp	151- 16- D9		BK	1
C500	In lower front of LH front door, to left front window motor	151- 15- E1		GY	2
C502	In rear of LH front door, on left front door lock motor	151- 15- D1		N	2
C503	In center of LH front door, on master window control switch and left door lock control switch	151- 15- A1	.. 150-23		15
C504	In lower rear of LH front door, on left front door courtesy lamp	151- 16- C1		BK	2
C507	In top front of LH front door, on left front door speaker	151- 15- A4		GY	2
	In front of LH front door, to left power mirror	151- 15- A2			4
	Behind RH cowl panel	151- 15- A8		GY	3
	In center of LH front door, near power mirror switch	151- 15- C1	.. 150-16	GY	8
	In lower front of RH door, to right front window motor	151- 15- F8		GY	2



BUY IT NOW!

Click Here To Order





**100% SATISFACTION GUARANTEED**

**BUY IT NOW!**

**Click Here To Order**



**WE SUPPORT VOLUNTARY  
TECHNICIAN CERTIFICATION**

---

---

---



**TECHNICAL  
PUBLICATION DEPARTMENT**  
Ford Parts and Service Division

LITHO IN U.S.A.  
AUGUST 1991

FPS-12229-92  
Copyright © 1991  
Ford Motor Company