



1 MUSTANG

**Electrical &
Vacuum
Trouble-
Shooting
Manual**

DEMO

This DEMO contains only a few pages of the entire manual/product.

Not all Bookmarks work on the Demo, but they do on the full version.

Features:

- Searchable text
- Printable pages
- Bookmarked for easy navigation
- High Resolution images
- Zoom to see exact details
- Money back Guarantee
- Available on USB and eBook download



License #84356800

Copyright © 2023, Forel Publishing Company, LLC, Woodbridge, Virginia

All Rights Reserved. No part of this book may be used or reproduced in any manner whatsoever without written permission of Forel Publishing Company, LLC. For information write to Forel Publishing Company, LLC, Woodbridge, VA 22192

**1991 Mustang Electrical & Vacuum
Trouble-Shooting Manual (EVTM)
EAN: 978-1-60371-402-0
ISBN: 1-60371-402-2**

Forel Publishing Company, LLC
Woodbridge, VA 22192
Email: sales@ForelPublishing.com
<https://www.ForelPublishing.com>



This publication contains material that is reproduced and distributed under a license from Ford Motor Company. No further reproduction or distribution of the Ford Motor Company material is allowed without the express written permission of Ford Motor Company.

Note from the Publisher

This product was created from the original Ford Motor Company's publication. Every effort has been made to use the original scanned images, however, due to the condition of the material; some pages have been modified to remove imperfections.

Disclaimer

Although every effort was made to ensure the accuracy of this book, no representations or warranties of any kind are made concerning the accuracy, completeness or suitability of the information, either expressed or implied. As a result, the information contained within this book should be used as general information only. The author and Forel Publishing Company, LLC shall have neither liability nor responsibility to any person or entity with respect to any loss or damage caused, or alleged to be caused, directly or indirectly by the information contained in this book. Further, the publisher and author are not engaged in rendering legal or other professional services. If legal, mechanical, electrical, or other expert assistance is required, the professional should be sought.



ELECTRICAL AND VACUUM TROUBLESHOOTING MANUAL FPS-12121-91

FORD PARTS and SERVICE DIVISION

Quality is Job 1

Ford Parts and Service Division has developed a new format for the EVTVM for the 1991 Mustang. Our goal is to provide accurate and timely electrical and vacuum service information.

1991 EVTVM FEATURES

- **"HOW THE CIRCUIT WORKS"** descriptions that explain how each circuit works. These descriptions are designed to be used in conjunction with the Electrical Schematic.
- **Component Location** information, within each system, that tells where each component is located on the vehicle as well as a reference to a **"COMPONENT LOCATION VIEW."**
- **"COMPONENT TESTING"** procedures (CELL 149) that tell the user how to perform diagnostic tests on various circuits.
- **Connector End Views ("COMPONENT CONNECTOR FACES" CELL 150)** are shown for connectors with five or more cavities; and for connectors with ten or more cavities, a circuit function chart is provided.
- **NOTES, CAUTIONS and WARNINGS** that contain important safety information.
- Full view **"COMPONENT LOCATION VIEWS"** (CELL 151) to help locate on-vehicle components.
- **Component Base Part Numbers and Harness Base Part Numbers** to aid in ordering parts.
- **Cellular Pagination:** A specific section (or cell) in all EVTVMs is numbered by cell and starts with page 1. For example: **"HOW TO FIND ELECTRICAL CONCERNS"** is CELL 5 and begins with page 5-1.

... are listed for all electrical connectors. "C" numbers are listed
... are listed in numerical order in the "LOCATION INDEX"

... - A feedback sheet is provided on the last page.

ORDERING INFORMATION

Information about how to order additional copies of this publication or other Ford publications may be obtained by writing to Helm Incorporated at the address shown below or by calling 1-800-782-4356. Other publications available include:

- Shop Manuals
- Service Specification Books
- Car/Truck Wiring Diagrams
- Engine/Emissions Diagnosis Manuals

Helm Incorporated
P.O. Box 87150
Detroit, Michigan 48207



1-1 TABLE OF CONTENTS/INDEX

Table of Contents

How to Use This Manual	2-1
Helpful Reminders	3-1
Electrical Symbols	4-1
How to Find the Electrical Concern ..	5-1
Grounds	10-1
Circuit Protection/Fuse Panel	11-1
Charging System	12-1
Power Distribution	13-1
Starting System	20-1
Ignition System	21-1
Electronic Engine Control (2.3L EFI)	23-1
Electronic Engine Control (5.0L)	24-1
Speed Control	31-1
Cooling Fans	33-1
Shift Lock	37-1
Horn/Cigar Lighter	44-1
Air Bag Restraint System	46-1
Heater	53-1
Air Conditioner/Heater	54-1
Rear Window Defrost	56-1
Instrument Cluster	60-1
Vehicle Speed Sensor (VSS)	64-1
Warning Chime	66-1
Instrument Illumination	71-1
Interval Wiper/Washer	81-1
Headlamps	85-1
Fog Lamps	86-1
Courtesy Lamps	89-1
Turn/Stop/Hazard Lamps	90-1
Exterior Lamps	92-1
Backup Lamps	93-1
Daytime Running Lamps	97-1
Power Windows	100-1
Convertible Top	102-1
.....	110-1
.....	113-1
.....	122-1
.....	124-1
.....	130-1
.....	140-1

How to Find Vacuum Concern	141-1
Vacuum Distribution	142-1
Component Testing	149-1
Connector Faces	150-1
Component Location Views	151-1
Location Index	152-1
Vehicle Repair Location Codes	160-1

Index

Air Bag Restraint System	46-1
Air Conditioner/Heater	
Vacuum	54-1
Electrical	
2.3L	54-2
5.0L	54-4
Backup Lamps	93-1
Charging System	12-1
Cigar Lighter	44-1
Circuit Protection/Fuse Panel	11-1
Component Testing	
A/C-Heater Control	149-6
Blower Motor Switch	149-7
Hazard Warning Switch	149-5
Ignition Switch	149-2
Interval Wiper/Washer Switch	149-3
Introduction	149-1
Main Light Switch	149-1
Multi-Function Switch	149-4
Convertible Top	102-1
Cooling Fans	33-1
Courtesy Lamps	89-1
Daytime Running Lamps	97-1
Defrost (Rear Window)	56-1
Electronic Engine Control	
2.3L	23-1
5.0L	24-1
Exterior Lamps	92-1
Fog Lamps	86-1
Fuse Panel	
Fuse 1	13-3
Circuit Breaker 2	13-2

Fuse 4	13-3, 13-7
Fuse 5	13-2, 13-6
Fuse 6	13-2, 13-5
Fuse 8	13-3, 13-4, 13-7
Fuse 9	13-2
Fuse 10	13-3, 13-5
Fuse 11	13-2
Fuse 12	13-3
Fuse 13	13-2
Circuit Breaker 14	13-2
Fuse 15	13-3, 13-7
Fuse 16	13-3
Fuse 18	13-2, 13-6
Gauges	
Fuel	60-2
Oil Pressure	60-2
Tachometer	60-2
Temperature	60-2
Voltmeter	60-2
Grounds	
G100	10-5
G102	10-1
G103	10-1
G104	
2.3L	10-3
5.0L	10-4
G105	
2.3L	10-3
5.0L	10-4
G106	10-3
G200	10-2
G201	
2.3L	10-3
5.0L	10-4
G301	10-7
G400	10-7
G401	10-10
G402	10-10
G500	10-6
Headlamps	85-1
Heater	53-1

100% SATISFACTION GUARANTEED

BUY IT NOW!

Click Here To Order

PayPal American Express Discover MasterCard VISA

TABLE OF CONTENTS/INDEX 1-2

Horn	44-1	Glove Box Lamp	89-2
Ignition Switch	13-2	Luggage Compartment	89-1
Ignition System	21-1	Map	89-2
Indicators		Vanity Mirror	89-2
Air Bag	60-3	Main Light Switch	13-7
Brake	60-3	Mirrors (Power)	124-1
Charge	60-1	Power Distribution	13-1
"Check Engine"	60-3	Power Door Locks	
"Check Oil"	60-3	Convertible	110-3
Fasten Belts	60-1	2 and 3 Door	110-1
Hi Beam	60-1	Power Lumbar Seats	122-1
Left Turn	60-1	Power Mirrors	124-1
Low Coolant	60-3	Power Windows	
Right Turn	60-1	Convertible	100-1
Instrument Cluster	60-1	2 and 3 Door	100-3
Instrument Illumination	71-1	Radio	
Interval Wiper/Washer	81-1	AM/FM Stereo	130-3
Lamps (Exterior)	92-1	Premium Sound	130-1
Backup	93-1	Rear Window Defrost	56-1
Courtesy	89-1	Seats (Lumbar)	122-1
Daytime Running	97-1	Shift Lock	37-1
Fog	86-1	Speed Control	31-1
Exterior	92-1	Starting System	20-1
Hazard	90-1	Trunk Lid Release	113-1
License	92-1	Vacuum Distribution	142-1
Park		Vacuum Symbols	141-1
Front	92-1	Vehicle Speed Sensor	64-1
Rear	92-2	Warning Chime	66-1
Side Marker		Wiper/Washer (Interval)	81-1
Front	92-1		
Rear	92-2		
Stop	90-2		
Stop (Hi Mount)	90-2		
Turn			
Front	90-1		
Rear	90-1		
Turn Signal	89-1		
Turn Signal (Hi Mount)	89-2		
Turn Signal (Low Mount)	89-1		

IMPORTANT SAFETY NOTICE

Appropriate service methods and proper repair procedures are essential for the safe, reliable operation of all motor vehicles, as well as the personal safety of the individual doing the work. This Manual provides general directions for accomplishing service and repair work with tested, effective techniques. Following them will help assure reliability.

There are numerous variations in procedures, techniques, tools, and parts for servicing vehicles, as well as in the skill of the individual doing the work. This Manual cannot possibly anticipate all such variations and provide advice or cautions as to each. Accordingly, anyone who departs from the instructions provided in this Manual must first establish that he compromises neither his personal safety nor the vehicle integrity by his choice of methods, tools or parts.



2-1 HOW TO USE THIS MANUAL

The purpose of this manual is to make troubleshooting easier by showing the electrical and vacuum circuits of these vehicles in a clear and simple fashion. With each circuit is a description of *How the Circuit Works* and some *Troubleshooting Hints*. A Component Location chart lists components and references to pictures in the manual.

Notes, Cautions and Warnings containing important information appear in boxes on text pages. Notes provide additional information to help complete a particular procedure. Cautions provide information that could prevent making an error that could damage the vehicle. Warnings provide information to prevent personal injury. The warnings list on the following page contains general warnings to follow when working on a vehicle.

Components which work together are shown together. For example, all electrical components used in any circuit are shown on one diagram. The circuit breaker or fuse is shown at the top of the page. All wires, connectors, splices, switches, and motors are shown in the flow of current to ground at the bottom of the page. Notes are included which describe how switches and other components work. If a component is used in several different circuits, it is shown in several places.

For example, the Main Light Switch is an electrical part of many circuits and is repeated on many pages. In some cases, however, a component may seem (by its name) to belong to a circuit where it has no electrical connection. But, be careful! Always check all wiring on the

Troubleshooting Hints point the technician in a general direction, but are not intended as a step-by-step procedure. Ignition troubleshooting is an exception to this. It includes a step-by-step procedure of basic quick checks to locate some of the more common Ignition System problems. Reading the shop manual provides more detailed repair procedures.

Connector end views of switches and other components are shown in Cell 149 (beginning on page 149-1) to help with bench testing. The views show the harness wire colors that connect to the mating terminals. Connector colors and locations are shown in the *Location Index* chart. Two-color listings indicate separate colors for each connector half.

A Location Index, in Cell 152 (beginning on page 152-1), identifies individual components, connectors and splices. This index describes the component, connector or splice location and directs you to the component illustrations. In addition, the component base part number has been included for your convenience in ordering parts. A list of harness base numbers, harness names and major systems associated with the respective harness base part number is also included within the Location Index.

The Grounds pages show detailed views of multiple component ground points. This is useful for checking interconnections among the ground circuits of different diagrams.

Component Connectors with 5 or more cavities are shown in Cell 150 (beginning on page 150-1) to help with system troubleshooting. Any component connector with 5-9 cavities will be shown with a connector end

view of the connector. A component with 10 or more connector cavities will have a pinout chart in addition to the connector face. The pinout chart contains information such as cavity number, wire number and color, and circuit function.

On some car lines, resistors and diodes are covered with PVC molds; terminals are also part of the molded assembly. The assembly plugs into a harness connector and is taped to the harness, outside the conduit.

In other cases, the resistor and diode assemblies will be covered with heat-shrinkable tubing, making the assembly small enough to be placed within the harness conduit.

The wiring diagrams show the number of times the resistors and diodes are used. The wiring diagrams also show the distance from connector/length of wire in exact centimeters. Resistors and diodes are identified on the wiring diagrams by the following base part numbers:

Resistor/diode assembly	14A601
Diode only	14A604

We welcome any comments you may have regarding this EVTm. Use the Feedback Sheet at the back of this manual to submit comments. The information submitted on this sheet will improve future editions.

SATISFACTION 100% GUARANTEED

BUY IT NOW!

Click Here To Order

PayPal American Express Discover MasterCard VISA

3-1 HELPFUL REMINDERS

Before using the EVTM for troubleshooting, refer to the HELPFUL REMINDERS described on this page.

1. The abbreviation T/O, for take out, used in the Component Location Chart, refers to the point at which a harness branches to feed a component. Refer to the wiring harness illustration.

Wiring harness at back of Instrument Panel, showing typical T/O (Take Out) locations

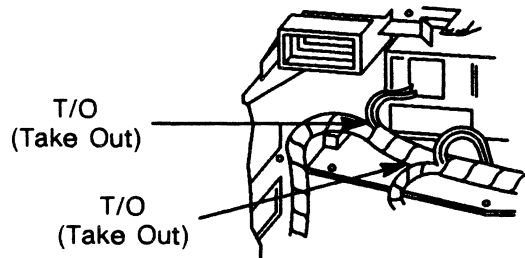

2. If a connector serves the same purpose in two separate versions (e.g., EFI/Carb), but is physically different, two connector numbers are used. However, if a connector serves the same purpose in two separate versions (e.g., EFI/Carb) and is physically the same, but the wire colors are different, only one connector number is used. If the same physical connector is used more than once, then more than one connector number is used.

3. Wiring diagrams provide a schematic picture of how and under what conditions the circuit is powered, of the current path to circuit components, and of how a circuit is grounded. Each circuit component is named (underlined titles). Wire and connector colors are listed (standard Ford color abbreviations are used):

COLOR ABBREVIATIONS

BL	Blue	N	Natural
BK	Black	O	Orange
BR	Brown	PK	Pink
DB	Dark Blue	P	Purple
DG	Dark Green	R	Red
GR	Green	T	Tan
GY	Gray	W	White
LB	Light Blue	Y	Yellow
LG	Light Green		

Whenever a wire is labeled with two colors, the first color listed is the basic color of the wire, and the second color listed is the stripe marking of the wire.

4. When reporting Vehicle Repair Location Codes to Ford Parts and Service Division, refer to Cell 160 (beginning on page 160-1).

Note: Do *not* use the illustrations in Cell 151 (beginning on page 151-1) for reporting Vehicle Repair Location Codes.

5. WARNINGS

- Always wear safety glasses for eye protection.
- Use safety stands whenever a procedure requires being under a vehicle.
- Be sure that the Ignition Switch is always in the OFF position, unless otherwise required by the procedure.
- Set the park brake when working on any vehicle. An automatic transmission should be in PARK. A manual transmission should be in NEUTRAL.
- Operate the engine only in a well-ventilated area to avoid danger of carbon monoxide.
- Keep away from moving parts when the engine is running, especially the fan and belts.
- To prevent serious burns, avoid contact with hot metal parts such as the radiator, exhaust manifold, tail pipe, catalytic converter and muffler.
- Do not allow flame or sparks near the battery. Gases are always present in and around the battery cell. An explosion could occur.
- Do not smoke.
- To avoid injury, always remove rings, watches, loose hanging jewelry and loose clothing.

100% SATISFACTION GUARANTEED

BUY IT NOW!

Click Here To Order

PayPal Discover NOWUS MasterCard VISA

4-1 ELECTRICAL SYMBOLS

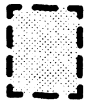

DASHED COMPONENT BOX
ONLY PART OF THE COMPONENT IS SHOWN ON THE PAGE; THE COMPONENT IS SHOWN COMPLETE IN ANOTHER LOCATION

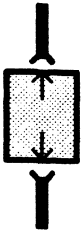

COMPONENT WITH CONNECTORS

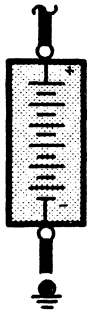

BATTERY

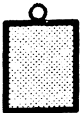

SCREW TERMINAL ON COMPONENT

SOLID STATE

SEALED ELECTRONIC COMPONENT
ANY CIRCUITRY SHOWN INSIDE THE BOX IS A FUNCTIONAL EQUIVALENT ONLY

100% SATISFACTION GUARANTEED

BUY IT NOW!

Click Here To Order

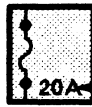

FUSE
CURRENT RATING

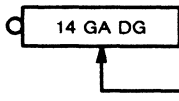

FUSIBLE LINK
WIRE SIZE AND COLOR



FUSIBLE LINK CARTRIDGE
CARTRIDGE CURRENT RATING

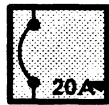

CIRCUIT BREAKER
CURRENT RATING

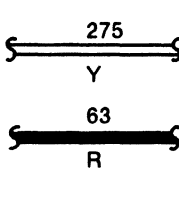

SOLID WIRES

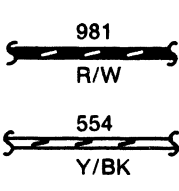

STRIPED WIRES

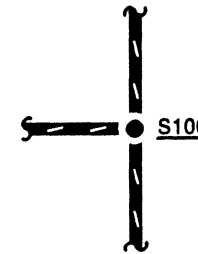

SPLICE OR CRIMP TERMINAL

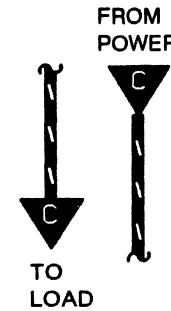

"CUT" WIRES REFERENCED BETWEEN PAGES
ARROWS SHOW CURRENT FLOW FROM POWER TO GROUND



"REFERENCE" WIRES
COMPLETE WIRING SHOWN ON ANOTHER PAGE

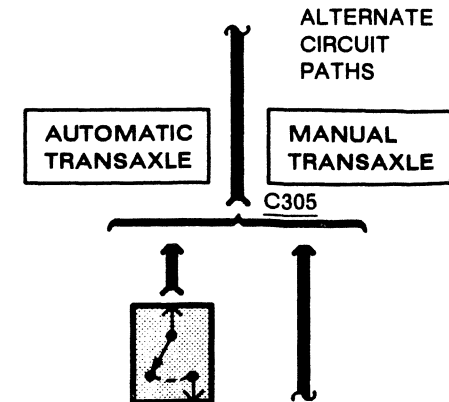

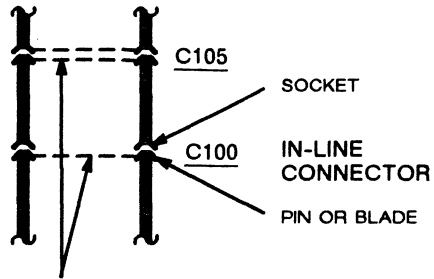

SINGLE OR DOUBLE DASHED LINE INDICATES THAT WIRE ON LEFT ALSO PASSES THROUGH THE SAME CONNECTOR

SEE GROUNDS
PAGES 10-1,
10-2

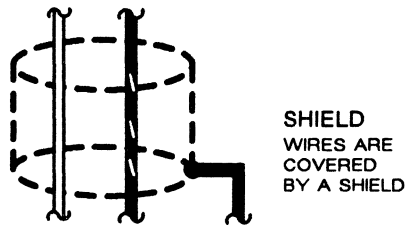
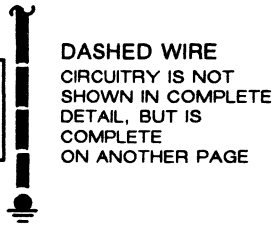

MOTOR



HEATING ELEMENT



THERMISTOR



RHEOSTAT OR POTENTIOMETER



SOLENOID



SWITCH

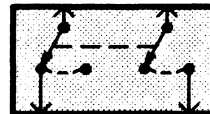

GANGED SWITCHES CONTACTS MOVE AT THE SAME TIME

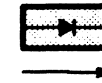

DIODES CURRENT FLOWS IN DIRECTION OF ARROW ONLY

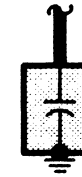

CAPACITOR



TRANSISTOR

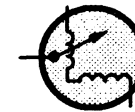

GAUGE



LIGHT BULB



DUAL FILAMENT LIGHT BULB

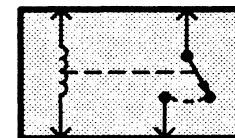

RELAY CONTACTS CHANGE POSITION WITH CURRENT THROUGH COIL

SATISFACTION 100% GUARANTEED

BUY IT NOW!

Click Here To Order

5-1 HOW TO FIND THE ELECTRICAL CONCERN

TROUBLESHOOTING STEPS

These six steps present an orderly method of troubleshooting.

Step 1. Verify the concern.

- Operate the complete system to check the accuracy and completeness of the customer's complaint.

Step 2. Narrow the concern.

- Using the EVTM, narrow down the possible causes and locations of the concern to pinpoint the exact cause.
- Read the description of *How the Circuit Works* and study the wiring diagram. You should then know enough about the circuit operation to determine where to check for the trouble. Further information can be found in the shop manual pages listed after *How the Circuit Works*.

Step 3. Test the cause.

- Use electrical test procedures to find the specific cause of the symptoms.
- *Troubleshooting Hints* will give you helpful ideas.
- The *Component Location Charts* and the pictures will help you find components. Following each chart, there is a reference to the Location Index at the end of the manual. This index gives component location information for connectors, diodes, resistors, splices and grounds.

Step 4. Verify the cause.

- Confirm that you have found the correct cause by connecting jumper wires and/or

Step 5. Make the repair.

- Repair or replace the inoperative component.

Step 6. Verify the repair.

- Operate the system as in Step 1 and check that your repair has removed all symptoms without creating any new symptoms.

Some engine circuits may need special test equipment and special procedures. See the *shop manual* and other service books for details. You will find these circuits in this manual to be helpful with these special tests.

TROUBLESHOOTING TOOLS

JUMPER WIRE

This is a test lead used to connect two points of a circuit. A Jumper Wire can complete a circuit, bypassing an open.

WARNING

Never use a jumper wire across loads (motors, etc.) connected between hot and ground. This direct battery short may cause injury or fire.

VOLTMETER

A DC Voltmeter measures circuit voltage. Connect negative (- or black) lead to ground, and positive (+ or red) lead to voltage measuring point.

OHMMETER

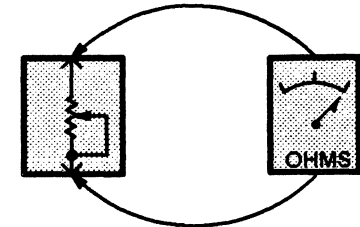

Figure 1-Resistance Check

An Ohmmeter shows the resistance between two connected points (Figure 1).

TEST LAMP

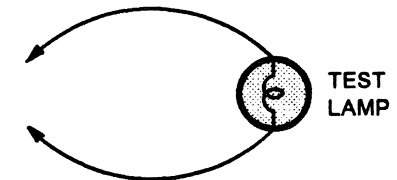

Figure 2-Test Lamp

A Test Light is a 12-volt bulb with two test leads (Figure 2).

Uses: Voltage Check, Short Check.

100% SATISFACTION GUARANTEED

BUY IT NOW!

Click Here To Order

PayPal American Express Discover MasterCard VISA

SELF-POWERED TEST LAMP

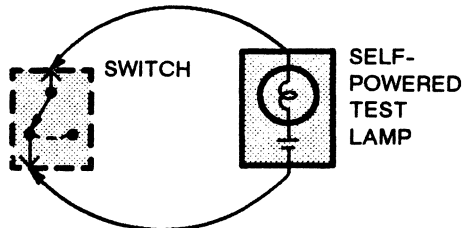

Figure 3—Continuity Check

The Self-Powered Test Lamp is a bulb, battery and set of test leads wired in series (Figure 3). When connected to two points of a continuous circuit, the bulb glows.

Uses: Continuity Check, Ground Check.

CAUTION

When using a self-powered test lamp or ohmmeter, be sure power is off in circuit during testing. Hot circuits can cause equipment damage and false readings.

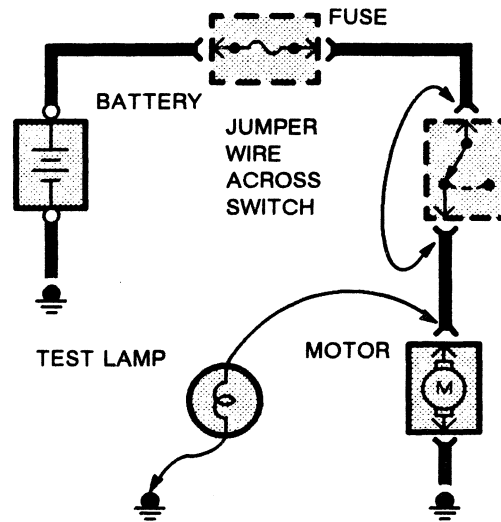

Figure 4—Switch Circuit Check and Voltage Check

In an inoperative circuit with a switch in series with the load, jumper the terminals of the switch to power the load. If jumpering the terminals powers the circuit, the switch is inoperative (Figure 4).

CONTINUITY CHECK (Locating open circuits)

Connect one lead of Self-Powered Test Lamp or Ohmmeter to each end of circuit (Figure 3). Lamp will glow if circuit is closed. Switches and fuses can be checked in the same way.

VOLTAGE CHECK

Connect one lead of test lamp to a known good ground or the negative (-) battery terminal. Test for voltage by touching the other lead to the test point. Bulb goes on when the test point has voltage (Figure 4).

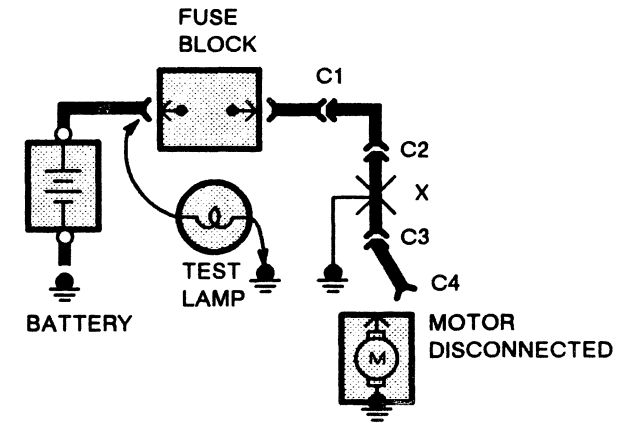

Figure 5—Short Check

A fuse that repeatedly blows is usually caused by a short to ground. It's important to be able to locate such a short quickly (Figure 5).

1. Turn off everything powered through the fuse.
2. Disconnect other loads powered through the fuse:
 - Motors: disconnect motor connector (Connector C4 in Figure 5).
 - Lights: remove bulbs.
3. Turn Ignition Switch to RUN (if necessary) to power fuse.
4. Connect one Test Lamp lead to hot end of blown fuse. Connect other lead to ground. Bulb should glow, showing power to fuse. (This step is just a check to be sure you have power to the circuit.)

100% SATISFACTION GUARANTEED

BUY IT NOW!

Click Here To Order

PayPal American Express Discover MasterCard VISA

5-3 HOW TO FIND THE ELECTRICAL CONCERN

5. Disconnect the test lamp lead that is connected to ground, and reconnect it to the load side of the fuse at the connector of the disconnected component. (In Figure 5, connect the test lamp lead to connector C4.)
- If the Test Lamp is off, the short is in the disconnected component.
 - If the Test Lamp goes on, the short is in the wiring. You must find the short by disconnecting the circuit connectors, one at a time, until the Test Lamp goes out. For example, in figure 5 with a ground at X, the bulb stays on when C1 or C2 is disconnected, but goes out after disconnecting C3. This means the short is between C2 and C3.

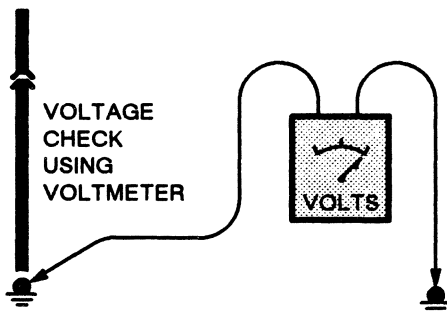

Figure 6—Ground Check

Turn on power to the circuit. Perform a Voltage Check between the suspected inoperative ground and the frame. Any indicated voltage means that the ground is inoperative.

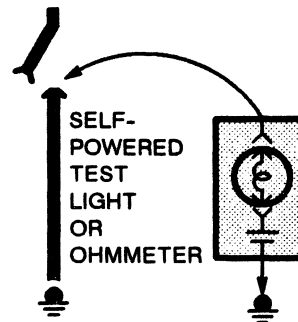

Figure 7—Ground Check

Turn off power to the circuit. Connect one lead of a Self-Powered Test Lamp or Ohmmeter to the wire in question and the other lead to a known ground. If the bulb glows, the circuit ground is OK (Figure 7).

TROUBLESHOOTING HINTS

The circuit schematics in this manual make it easy to identify common points in circuits. This knowledge can help narrow the concern to a specific area. For example, if several circuits fail at the same time, check for a common power or ground connection (See *Power Distribution* or *Grounds*). If part of a circuit fails, check the connections between the part that works and the part that doesn't work.

For example, if lo beam headlamps work, but hi beams and the indicator lamp don't work, then power and ground paths must be good. Since the dimmer switch is the component that switches this power to the high beam lights and indicator, it is most likely the cause of failure.

Troubleshooting Hints unique to a particular circuit are given in a new, three column format. Included in the charts are conditions that may develop, possible causes, and one or more tests that can be done quickly to determine the cause of the condition.

100% SATISFACTION GUARANTEED

BUY IT NOW!

Click Here To Order

PayPal American Express Discover MasterCard VISA



SATISFACTION 100% GUARANTEED

BUY IT NOW!

Click Here To Order

PayPal American Express Discover MasterCard VISA

10-1 GROUNDS (G102, G103)

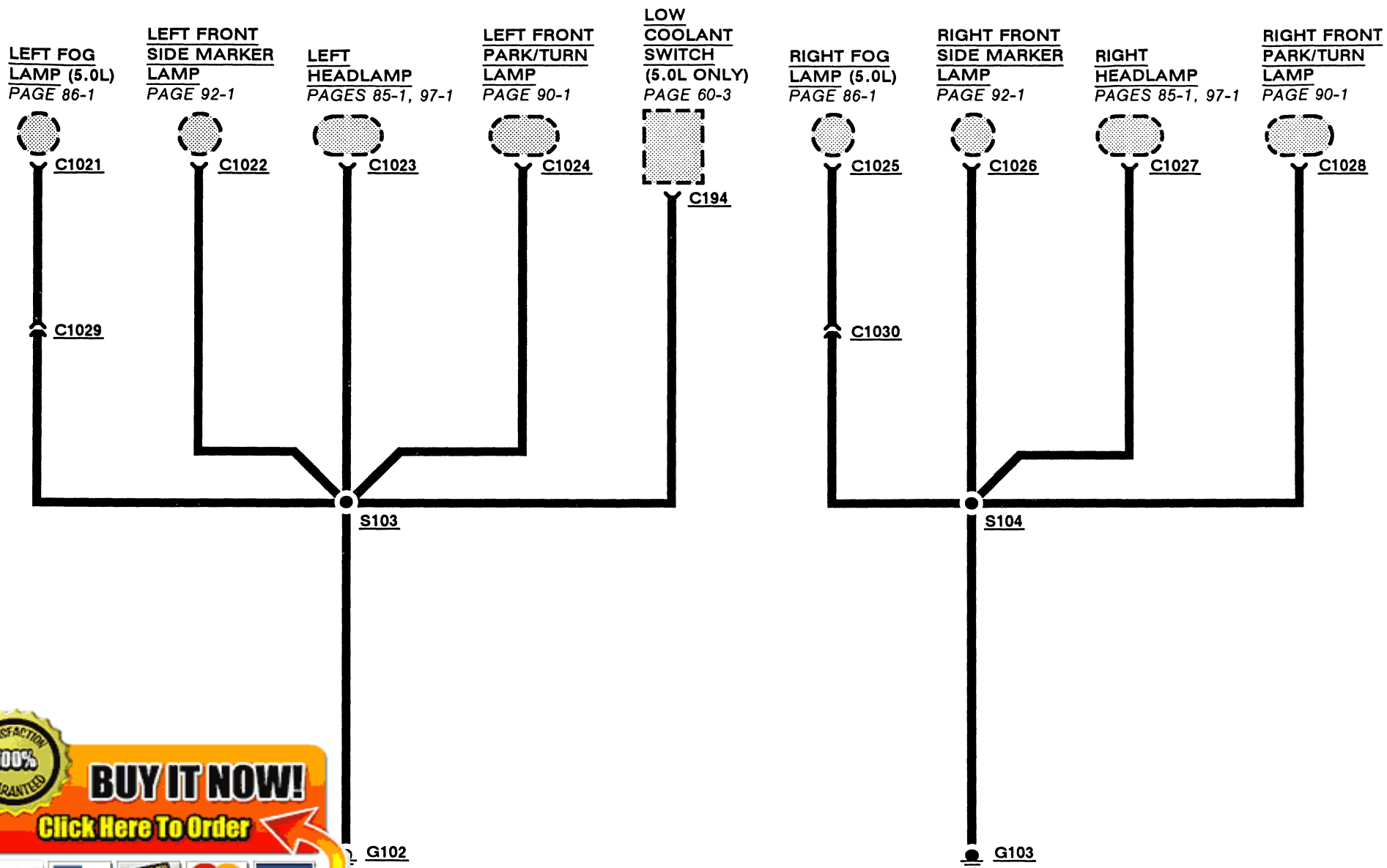

100% SATISFACTION GUARANTEED

BUY IT NOW!

Click Here To Order

PayPal, American Express, Discover, MasterCard, VISA

AIR BAG DIAGNOSTIC MODULE
PAGE 46-1



C277

C276

SHIFT LOCK ACTUATOR
PAGE 37-1

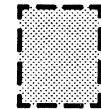

C2008

BLOWER MOTOR SWITCH
PAGES 53-2, 54-2

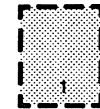

C2015

BLOWER MOTOR RESISTOR ASSEMBLY
PAGES 53-2, 54-2



C287

STEERING COLUMN AIR BAG
PAGE 46-2

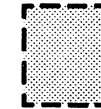

C2009

AIR BAG BACKUP POWER SUPPLY
PAGE 46-1



C284

S214

G200



BUY IT NOW!

Click Here To Order



10-3 GROUNDS (G104, G105, G106, G201)

2.3L

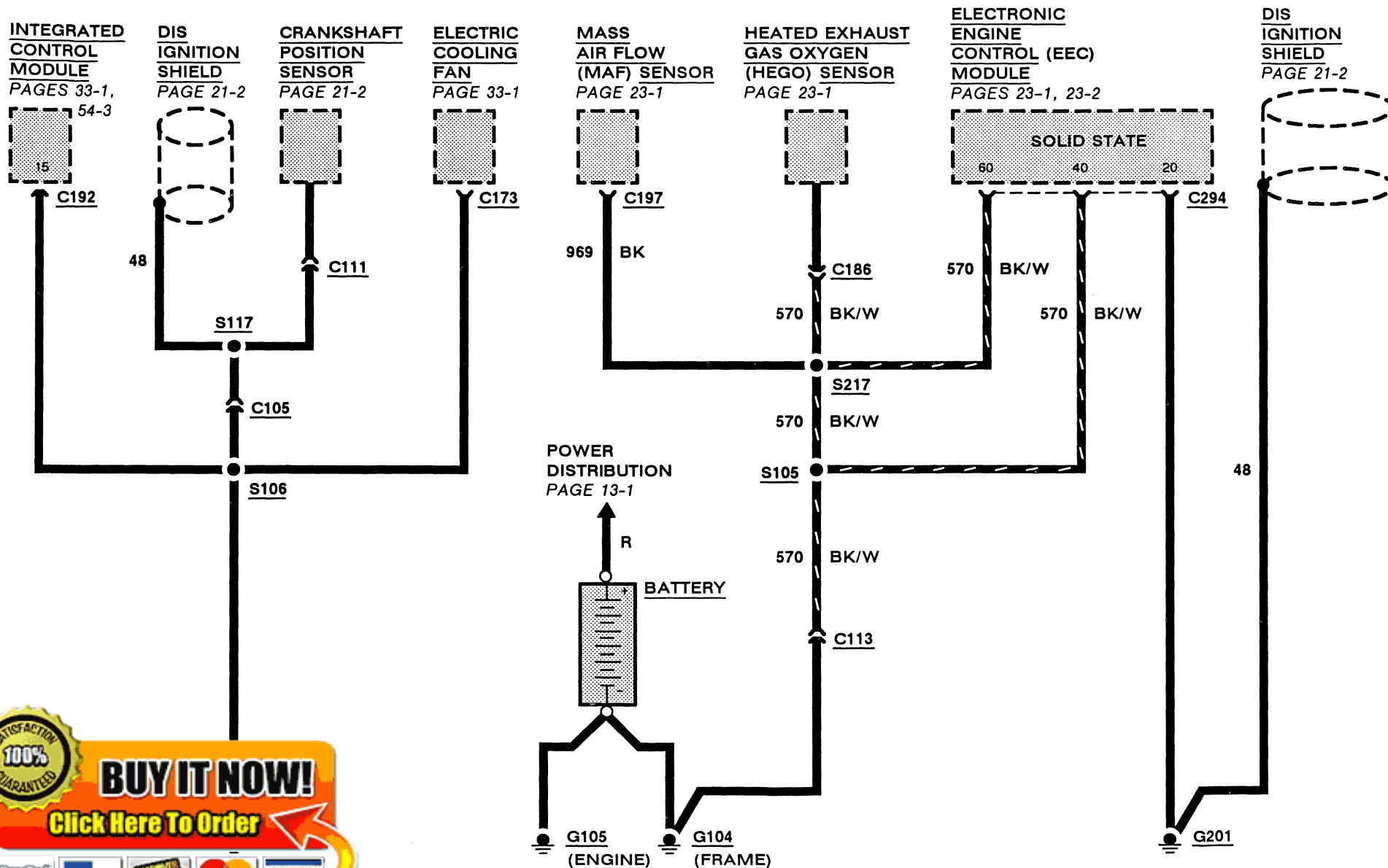

100% SATISFACTION GUARANTEED

BUY IT NOW!

[Click Here To Order](#)

5.0L

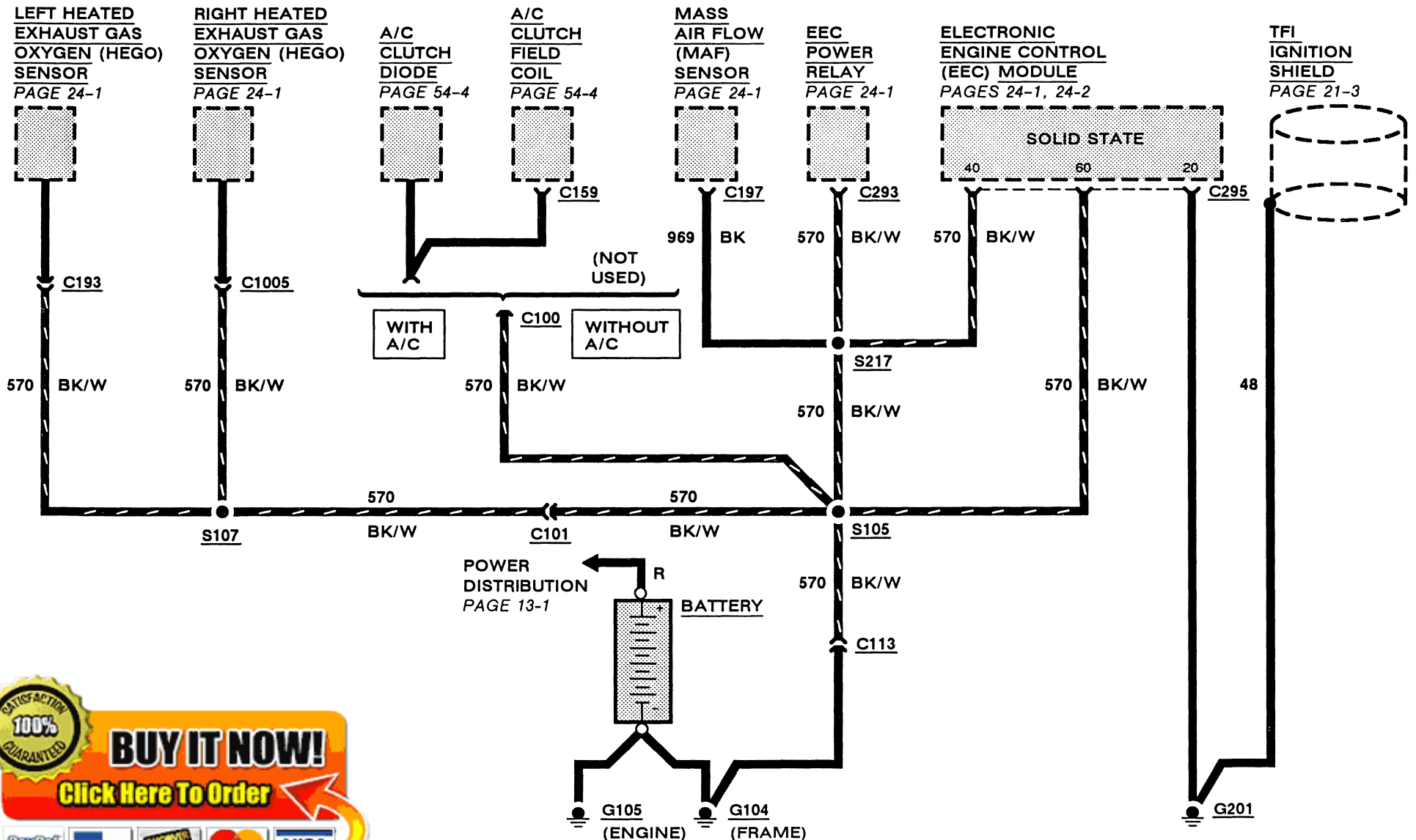

100% SATISFACTION GUARANTEED

BUY IT NOW!

[Click Here To Order](#)

10-5 GROUNDS (G100)

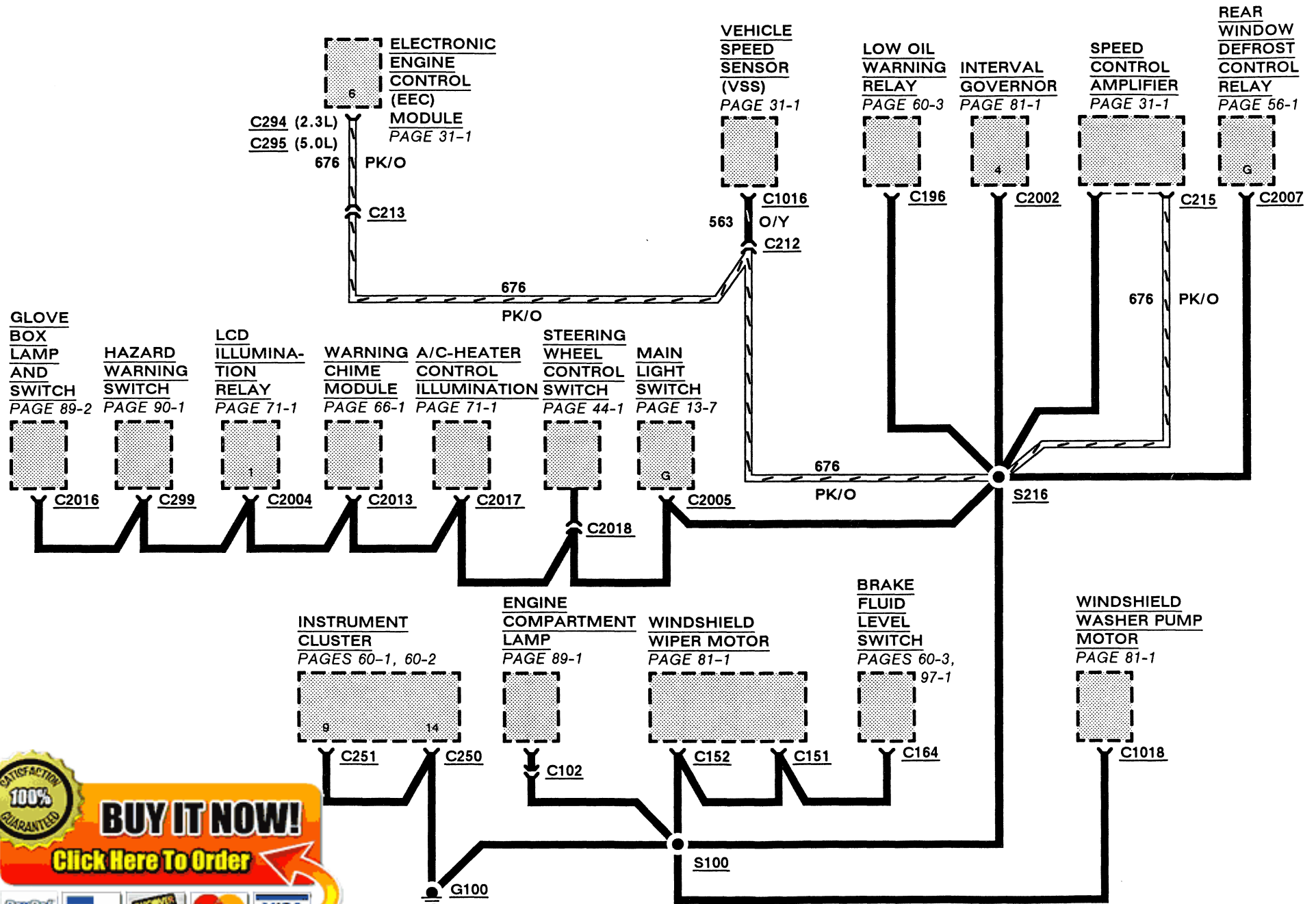

100% SATISFACTION GUARANTEED

BUY IT NOW!

[Click Here To Order](#)

2 AND 3 DOOR

CONVERTIBLE

WITH POWER WINDOWS

WITHOUT POWER WINDOWS

LEFT DOOR LOCK SWITCH
PAGE 110-1

MASTER WINDOW CONTROL SWITCH
PAGE 100-3

LEFT DOOR LOCK SWITCH
PAGE 110-2

MASTER WINDOW CONTROL SWITCH
PAGE 100-1

LEFT DOOR LOCK SWITCH
PAGE 110-3

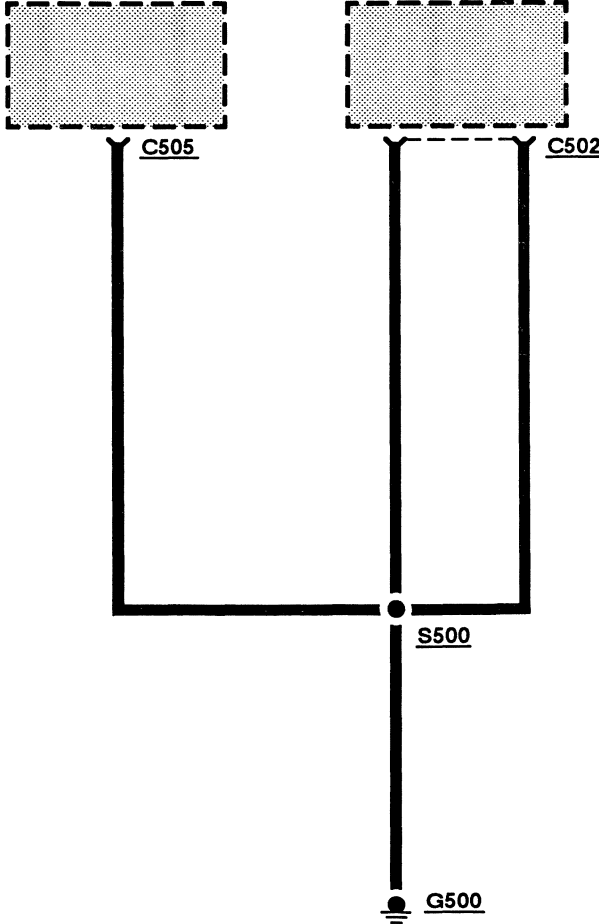
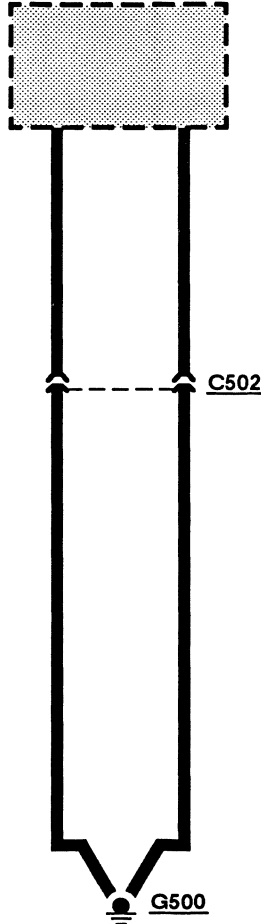
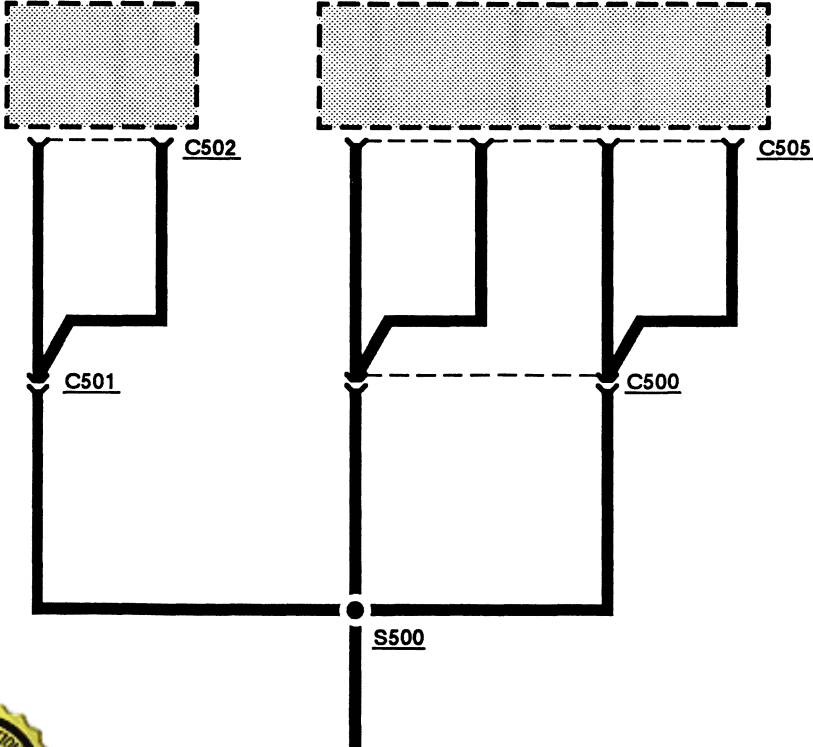

100% SATISFACTION GUARANTEED

BUY IT NOW!

Click Here To Order

10-7 GROUNDS (G301, G400)

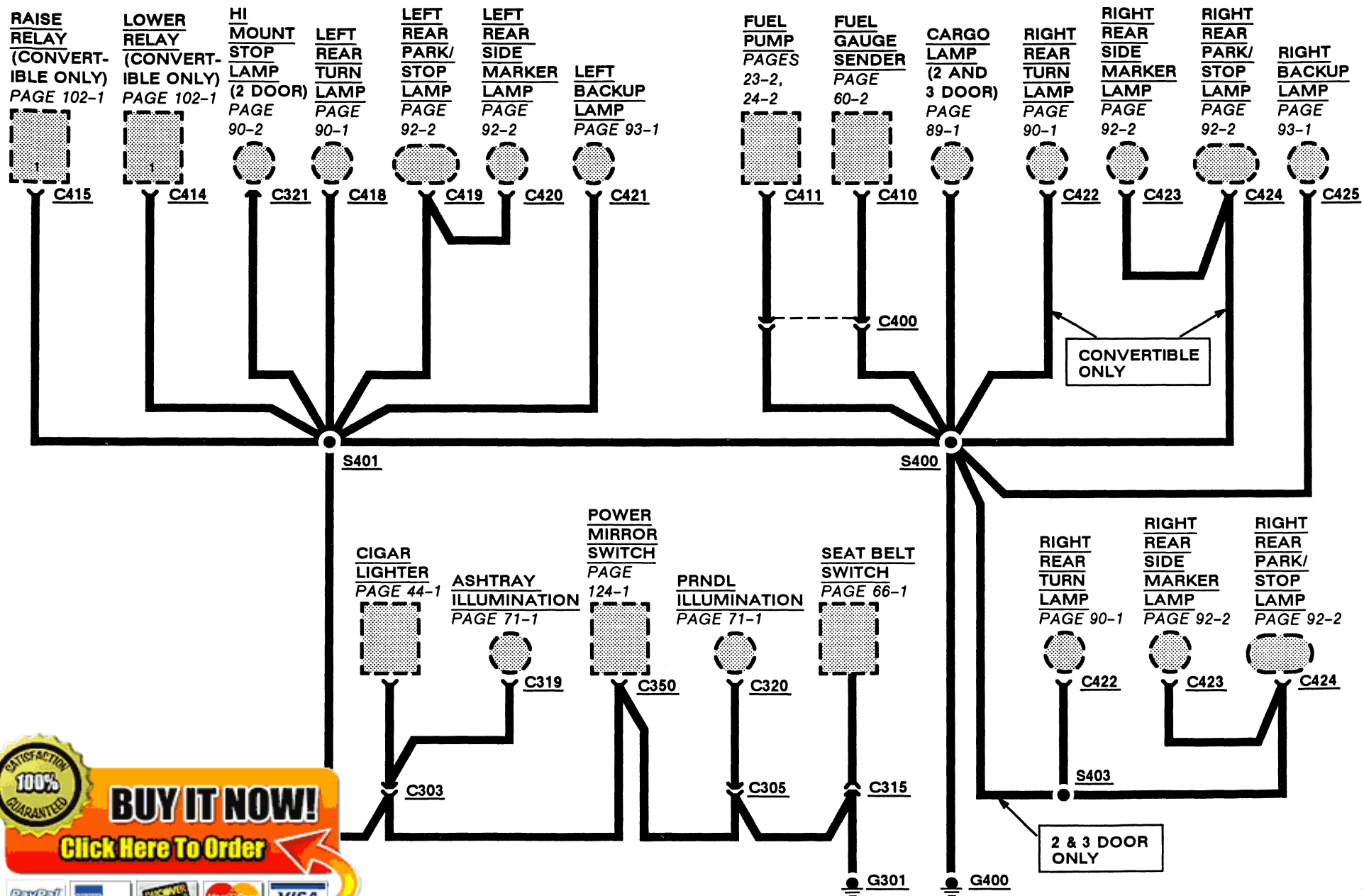

100% SATISFACTION GUARANTEED

BUY IT NOW!

Click Here To Order

Refer to Location Index, Cell 152, for Base Part Number information and Connector, Splice, Ground, Resistor and Diode locations.

HOW THE CIRCUIT WORKS

The ground circuits shown on the preceding pages are complete and connect several components together to screw terminal ground points. Parts of these circuits may be shown on other pages throughout the book. Partial circuits are depicted as broken wires.

Simple or component ground circuits are shown completely on individual circuit pages.

All wires are 57 (BK) unless otherwise noted.

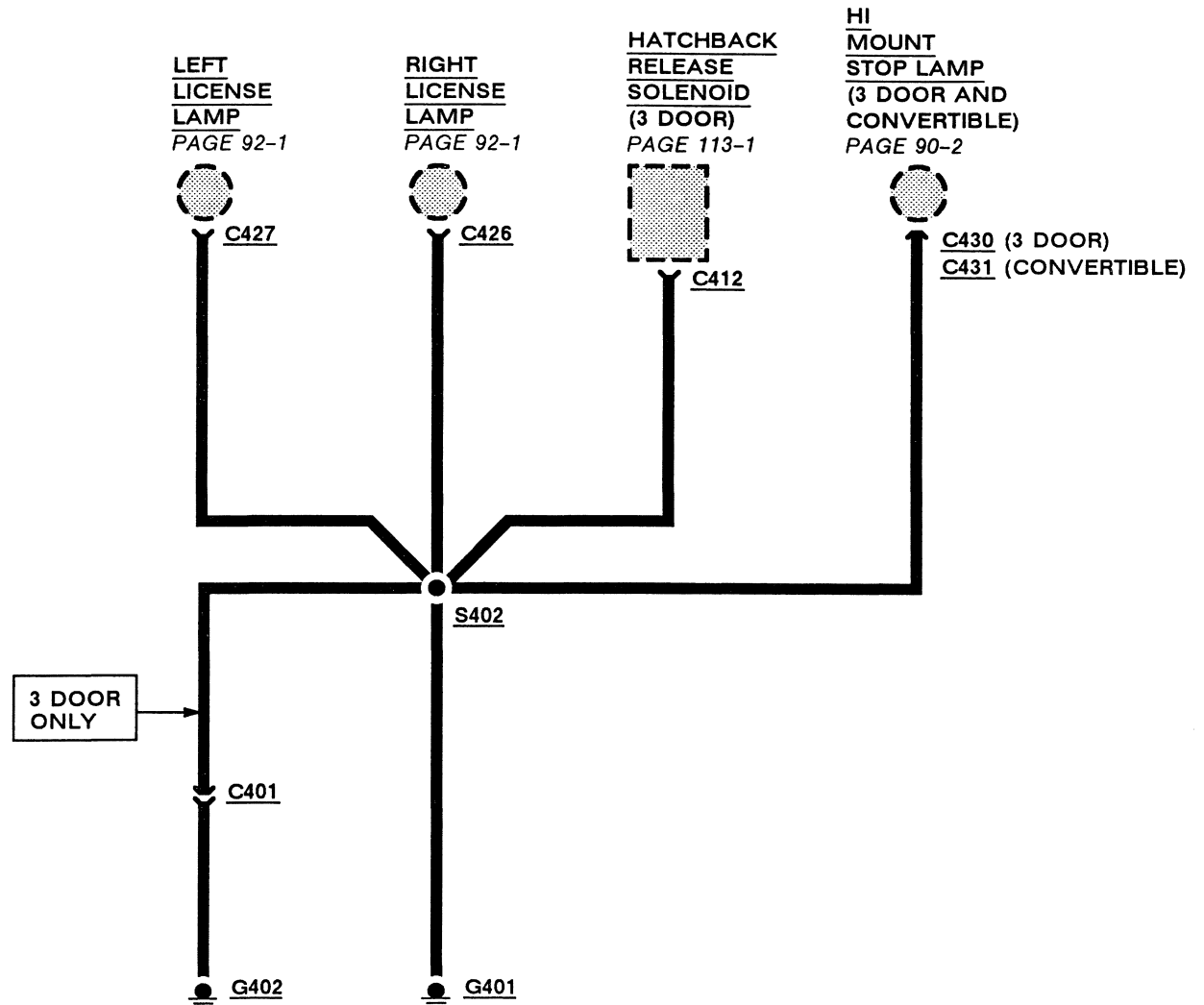

100% SATISFACTION GUARANTEED

BUY IT NOW!

Click Here To Order

11-1 CIRCUIT PROTECTION/FUSE PANEL

CIRCUIT PROTECTION DEVICES

Electrical circuits on this vehicle may be protected by fuses, fusible links, fusible link cartridges, circuit breakers, or a combination of these devices.

BLADE TYPE FUSE

TOP VIEW

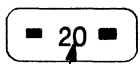

AMPERE RATING

SIDE VIEW

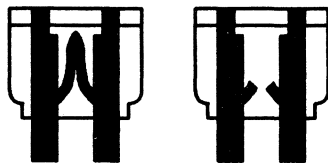

GOOD FUSE

BLOWN FUSE

Blade type fuses have a transparent plastic housing. To check a fuse, pull it from the fuse panel and look at the fuse element through the housing. Always replace a blown fuse with a new fuse that has the same ampere rating.

The ampere rating of a blade type fuse can also be determined by following the color code shown here:

BLADE FUSE COLOR CODING	
AMPERE RATING	HOUSING COLOR
4	Pink
5	Tan



BUY IT NOW!

Click Here To Order



FUSIBLE LINK

CUT-AWAY VIEW

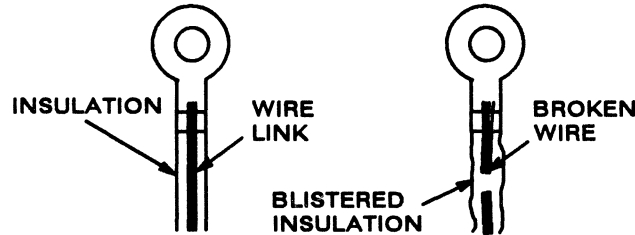

GOOD LINK

BLOWN LINK

Fusible links are short lengths of wire that are smaller in diameter than the wires they are protecting. Fusible link wire is covered with a special thick, non-flammable insulation. An overload condition causes the insulation to blister. If the overload condition continues, the wire link will melt. To check a fusible link, look for blistered insulation. If the insulation is okay, pull lightly on the wire; if the fusible link stretches, the wire has melted.

When replacing fusible links, first cut the protected wire where it is connected to the fusible link. Then, tightly crimp or solder the new link to the protected wire.

Fusible links are often identified by color coding of the insulation, as shown here:

FUSIBLE LINK COLOR CODING	
WIRE LINK SIZE	INSULATION COLOR
20 GA	Blue
18 GA	Brown or Red
16 GA	Black or Orange
14 GA	Green
12 GA	Gray

FUSIBLE LINK CARTRIDGE

SIDE VIEW



GOOD



BLOWN

TOP VIEW

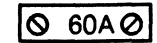

AMPERE RATING

Fusible link cartridges have a transparent colored plastic housing. To check a fusible link cartridge, look at the fuse element through the side of the housing.

To replace a fusible link cartridge, pull it from the fuse box or panel. Always replace a blown fusible link cartridge with a new one having the same ampere rating.

The ampere rating of a fusible link cartridge can also be determined by following the color code shown here:

FUSIBLE LINK CARTRIDGE COLOR CODING	
AMPERE RATING	HOUSING COLOR
30	Light Green
40	Amber
50	Red
60	Blue

150-23 CONNECTOR FACES/PINOUT CHARTS

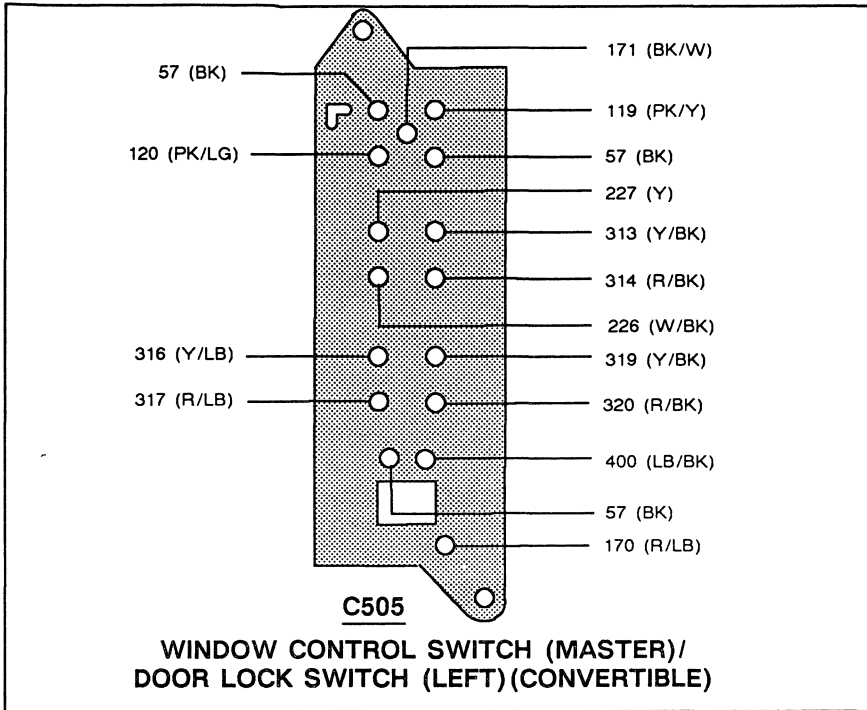

CIRCUIT	CIRCUIT FUNCTION
227 (Y)	Left Front Window Motor
313 (Y/BK)	Right Front Window Motor
226 (W/BK)	Left Front Window Motor
314 (R/BK)	Right Front Window Motor
316 (Y/LB)	Left Rear Window Motor
319 (Y/BK)	Right Rear Window Motor
317 (R/LB)	Left Rear Window Motor
320 (R/BK)	Right Rear Window Motor
57 (BK)	Ground (Window Control Switch)
400 (LB/BK)	12V Power Feed
	Lock Switch Output
	Lock Motors
	(Door Lock Switch)
	Power Feed
	Window Motors
	Door Lock Switch

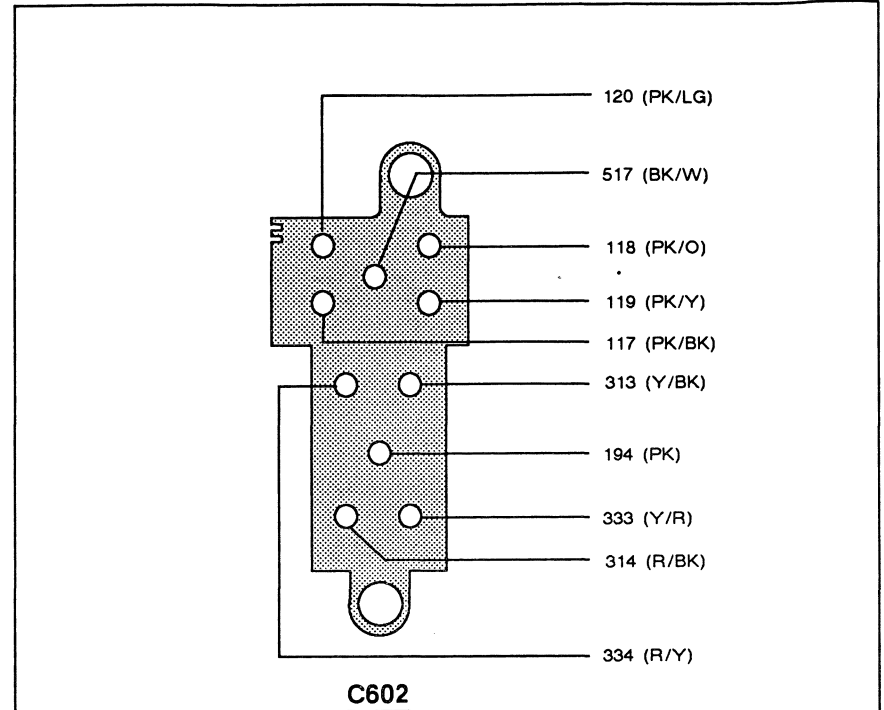

CIRCUIT	CIRCUIT FUNCTION
334 (R/Y)	Right Front Window Motor
313 (Y/BK)	Master Window Control Switch Feed
194 (PK)	12V Power Feed
333 (Y/R)	Right Front Window Motor
314 (R/BK)	Master Window Control Switch Feed
120 (PK/LG)	Passenger's Door Lock Switch Feed
118 (PK/O)	Door Lock Motors
517 (BK/W)	12V Power Feed
117 (PK/BK)	Door Lock Motors
119 (PK/Y)	Passenger's Door Lock Switch Feed

100% SATISFACTION GUARANTEED

BUY IT NOW!

Click Here To Order

CONNECTOR FACES/PINOUT CHARTS 150-24

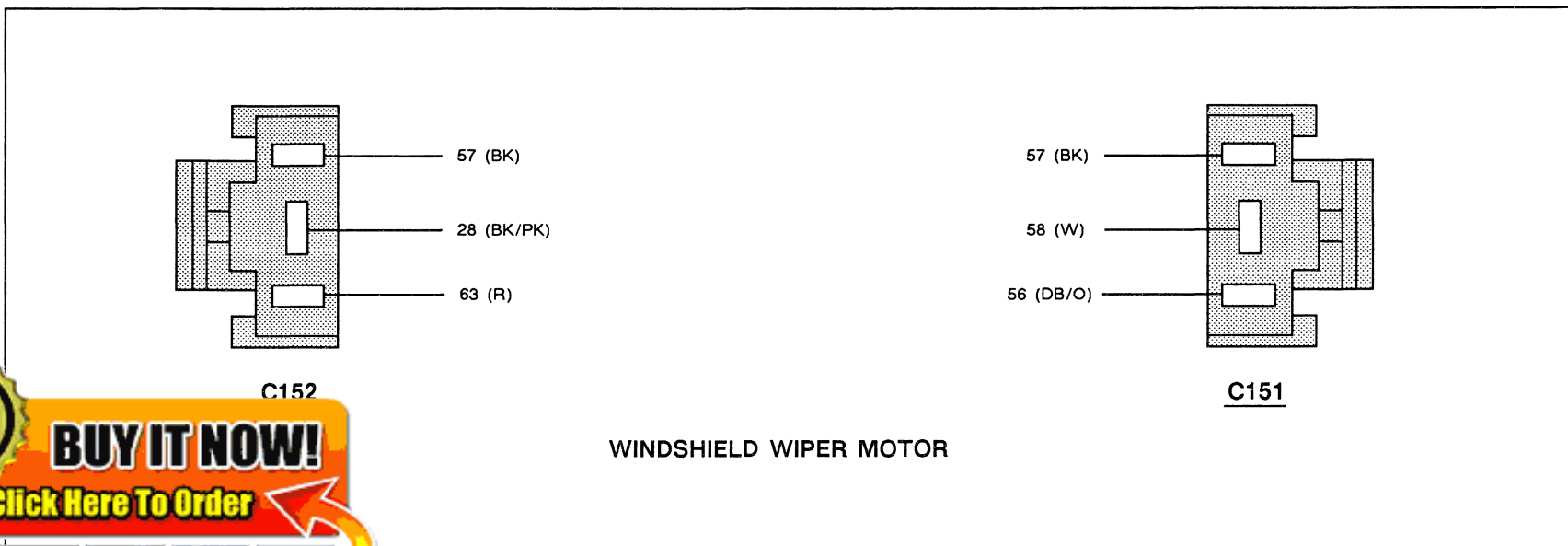
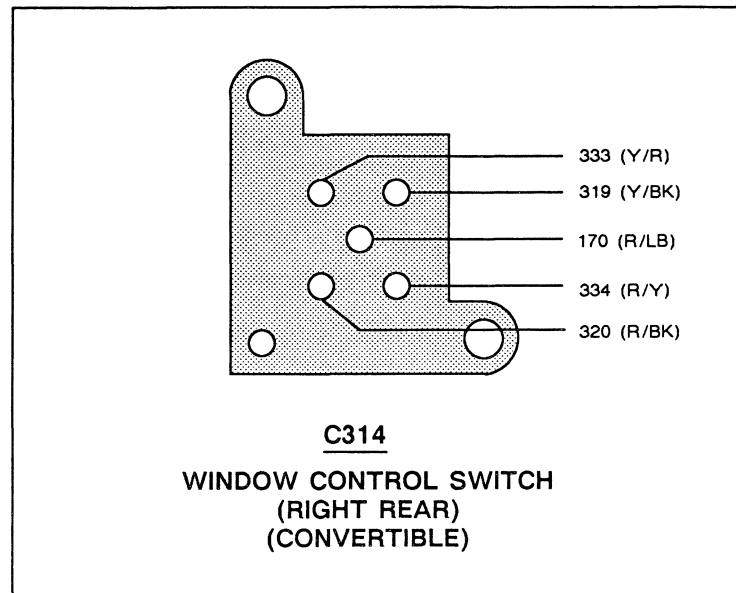
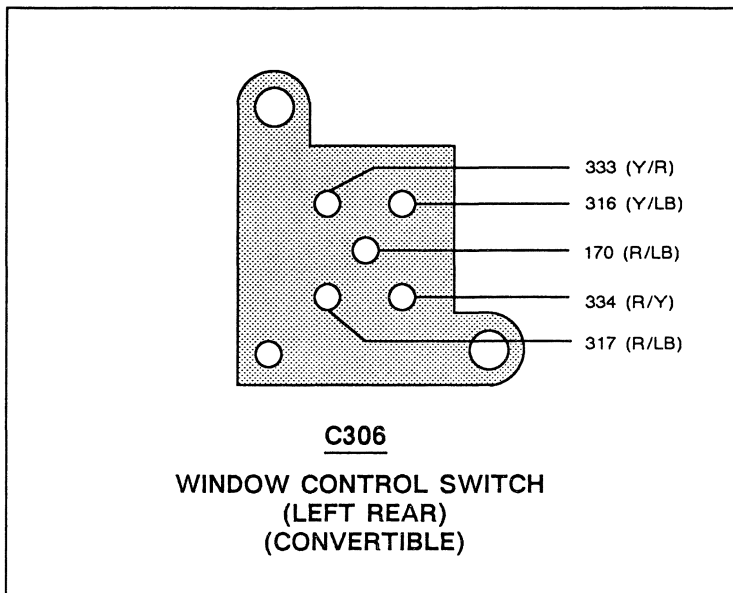

100% SATISFACTION GUARANTEED

BUY IT NOW!

Click Here To Order

150-25 CONNECTOR FACES/PINOUT CHARTS

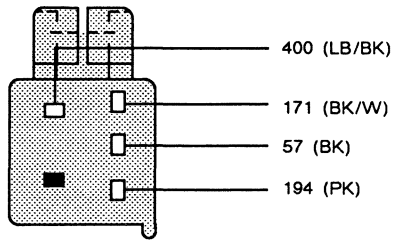

C2014
WINDOW SAFETY
RELAY

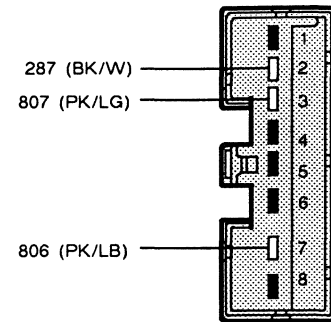

C2031
RADIO
(WITH PREMIUM SOUND,
WITH GRAPHIC EQUALIZER)

PIN NUMBER	CIRCUIT	CIRCUIT FUNCTION
1	—	NOT USED
2	287 (BK/W)	Common
3	807 (PK/LG)	Left Channel Audio Input
4	—	NOT USED
5	—	NOT USED
6	—	NOT USED
7	806 (PK/LB)	Right Channel Audio Input
8	—	NOT USED

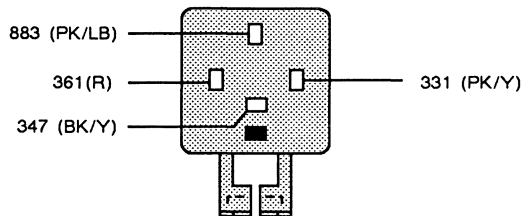

C1020
RELAY
(LY)

100% SATISFACTION GUARANTEED

BUY IT NOW!

Click Here To Order

CONNECTOR FACES/PINOUT CHARTS 150-26

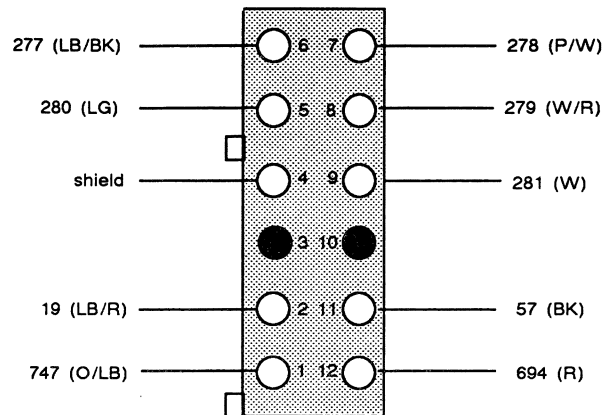

C2030

GRAPHIC EQUALIZER

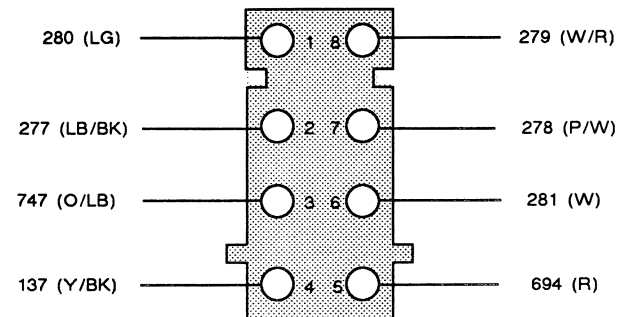

C282

**PREMIUM SOUND AMPLIFIER
WITH GRAPHIC EQUALIZER**

PIN NUMBER	CIRCUIT	CIRCUIT FUNCTION
1	747 (O/LB)	Radio
2	19 (LB/R)	Instrument Dimming
3	—	NOT USED
4	shield	Grounding of Cable Shield
5	280 (LG)	Left Front Speaker Signal (+)
6	277 (LB/BK)	Left Rear Speaker Signal (+)
7	278 (P/W)	Right Rear Speaker Signal (+)
		Right Front Speaker Signal (+)
		Speaker Common
		NOT USED
		Illumination Ground
		Power Ground

PIN NUMBER	CIRCUIT	CIRCUIT FUNCTION
1	280 (LG)	Left Front Speaker Signal (+)
2	277 (LB/BK)	Left Rear Speaker Signal (+)
3	747 (O/LB)	Radio On Signal
4	137 (Y/BK)	12 V Power Feed
5	694 (R)	Ground
6	281 (W)	Signal Ground
7	278 (P/W)	Right Rear Speaker Signal (+)
8	279 (W/R)	Right Front Speaker Signal (+)

100% SATISFACTION GUARANTEED

BUY IT NOW!

Click Here To Order

151-1 COMPONENT LOCATION VIEWS

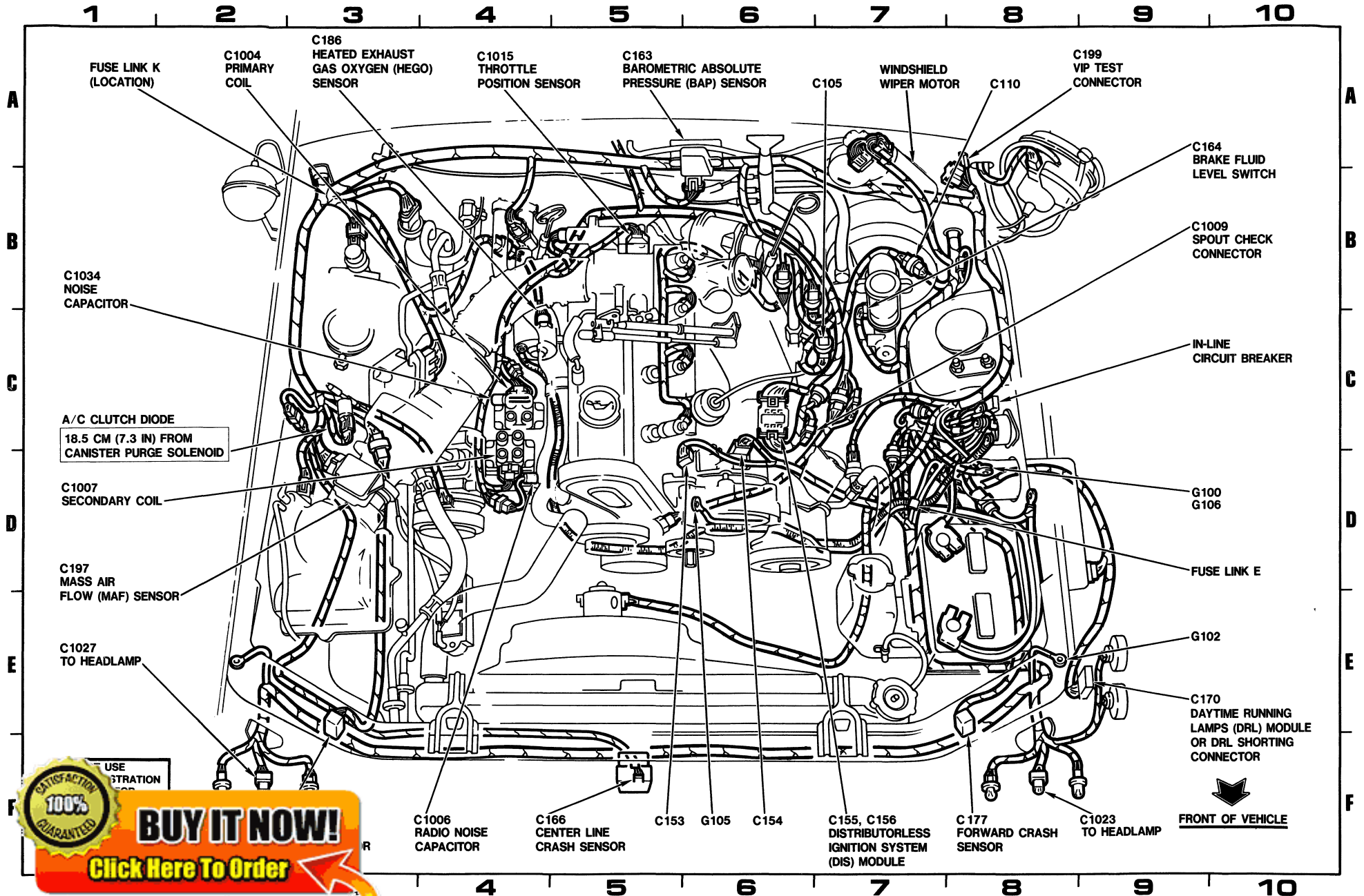

2.3L Engine (1 of 2)

USE REGISTRATION

100% SATISFACTION GUARANTEED

BUY IT NOW!

Click Here To Order

COMPONENT LOCATION VIEWS 151-2

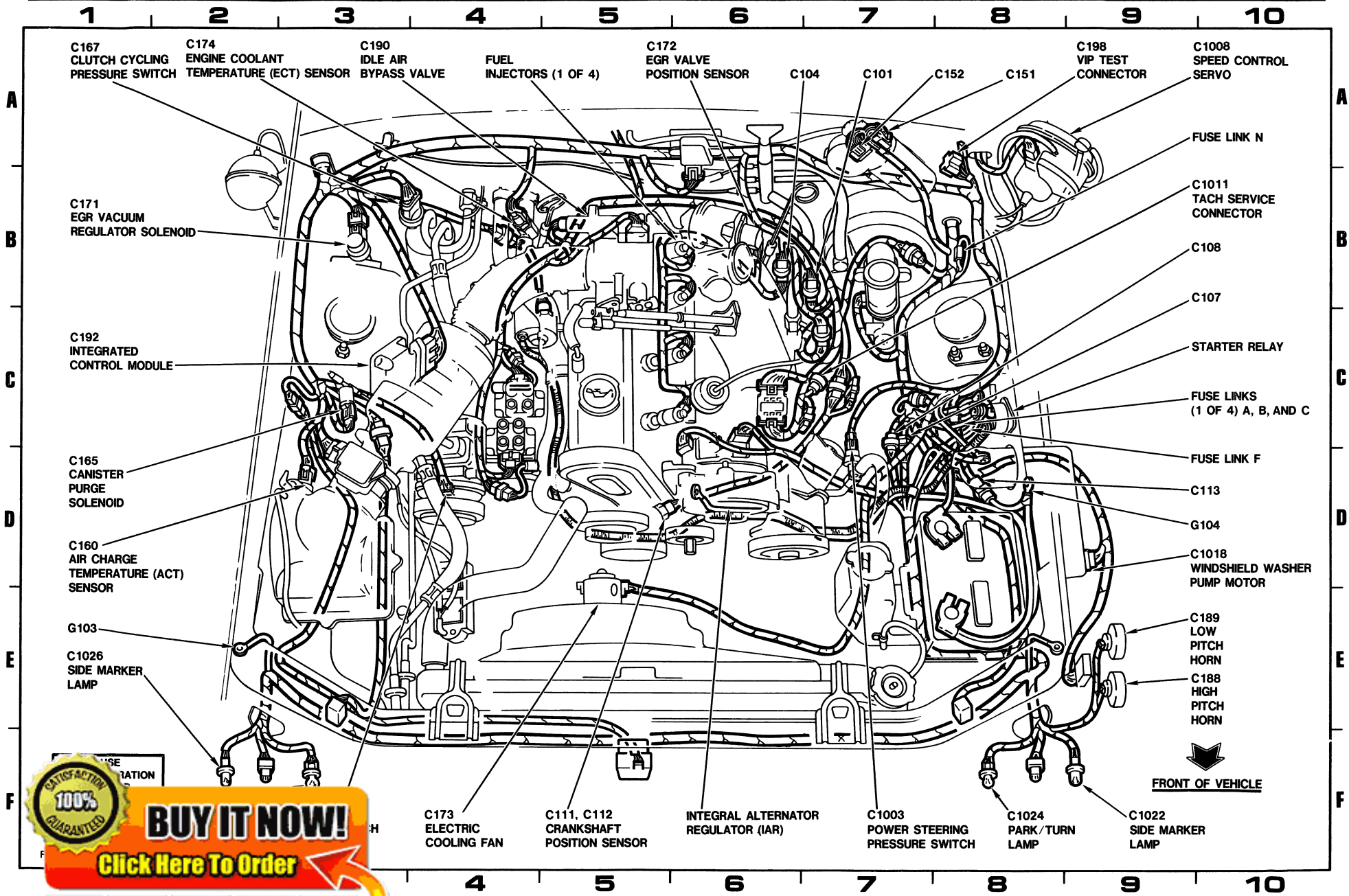

BUY IT NOW!
[Click Here To Order](#)





2.3L Engine (2 of 2)



Click Here To Order

BUY IT NOW!

COMPONENT LOCATION VIEWS

2 3 4 5 6 7 8 9 10

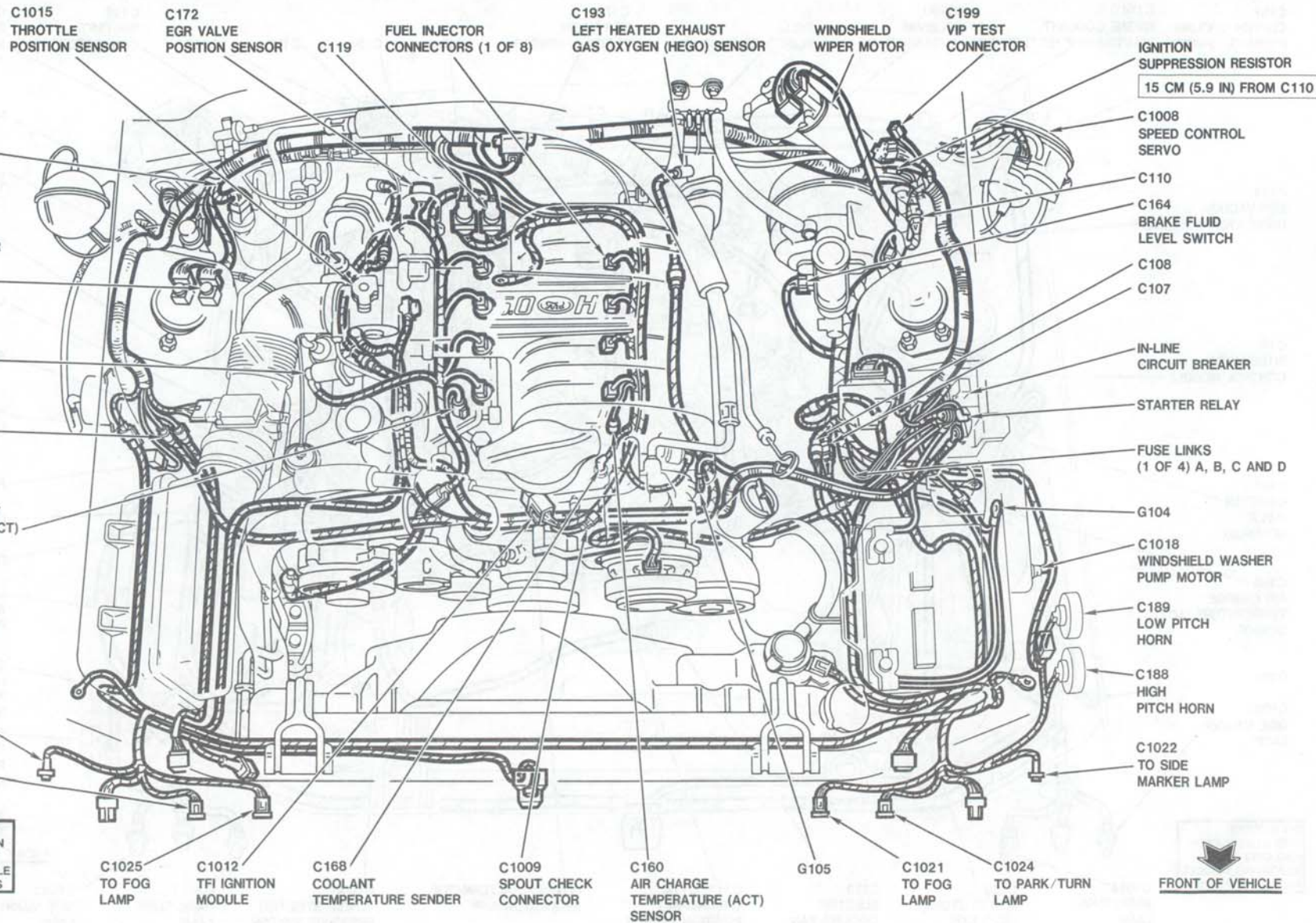

DO NOT USE THIS ILLUSTRATION AND GRID FOR REPORTING VEHICLE REPAIR LOCATIONS



FPS-12121-91 (3 OF 4)

1 2 3 4 5 6 7 8 9 10

5.0L Engine (1 of 2)

COMPONENT LOCATION VIEWS 151-4







100% SATISFACTION GUARANTEED
BUY IT NOW!
[Click Here To Order](#)

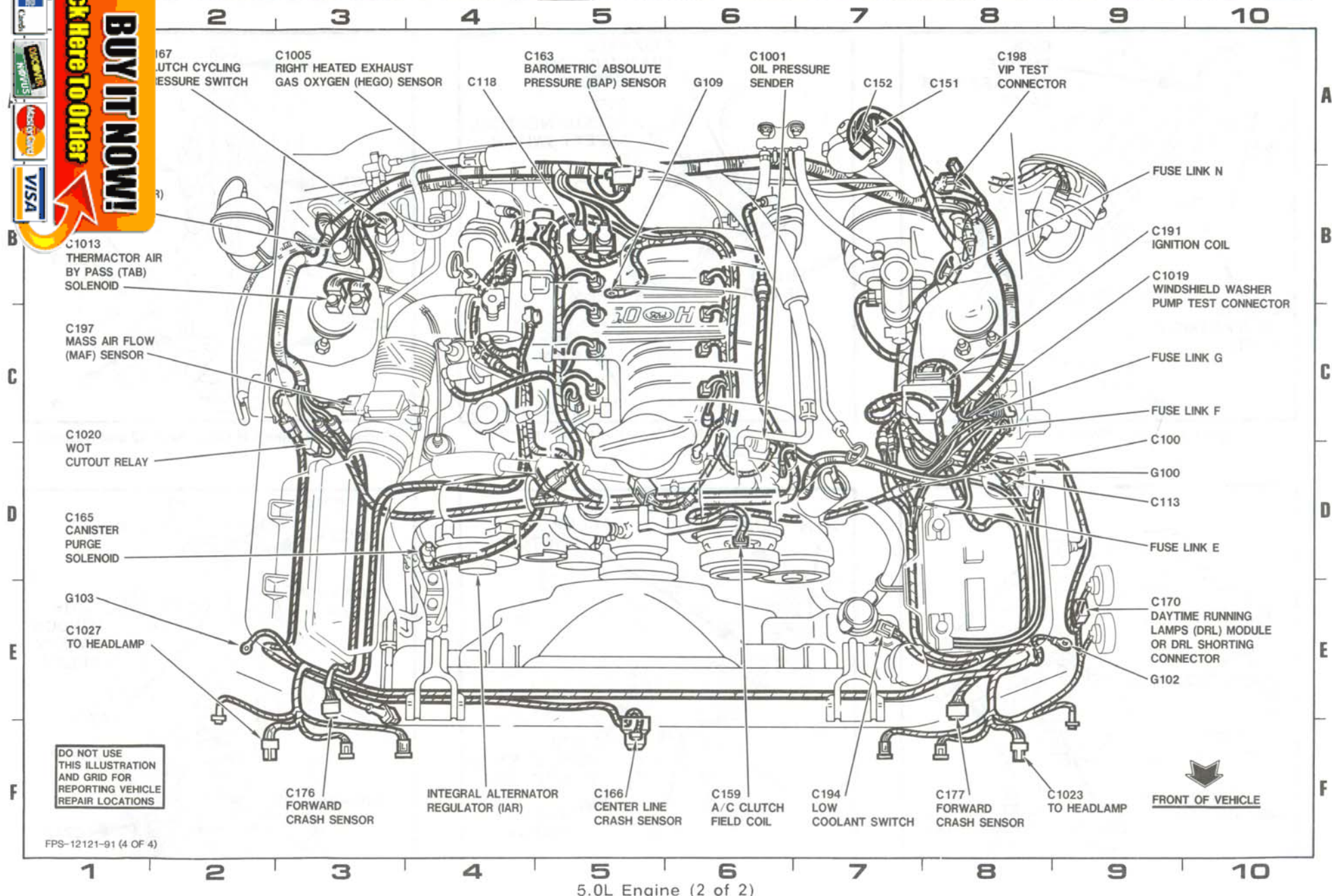







100% SATISFACTION GUARANTEE
BUY IT NOW!
[Click Here To Order](#)

COMPONENT LOCATION VIEWS

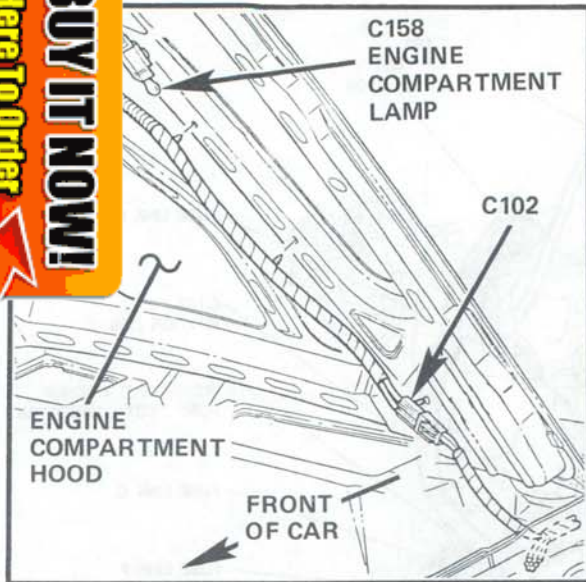

Figure 1 - Engine Compartment Hood

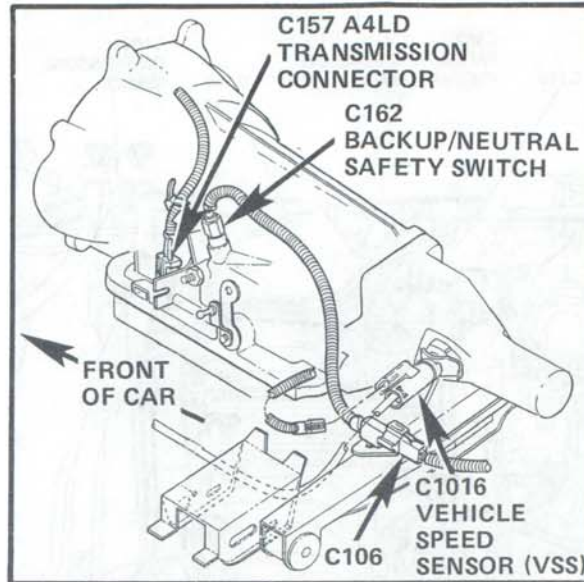

Figure 3 - LH Side of Automatic Transmission (2.3L Shown; 5.0L Similar)

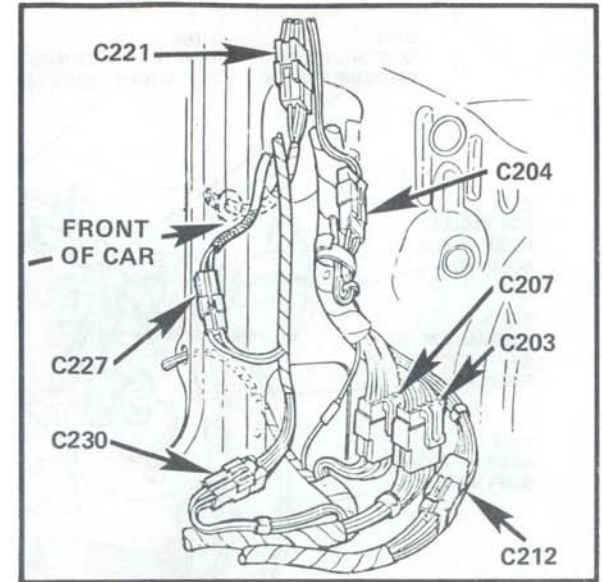

Figure 5 - Behind LH Cowl Panel (2 and 3 Door)

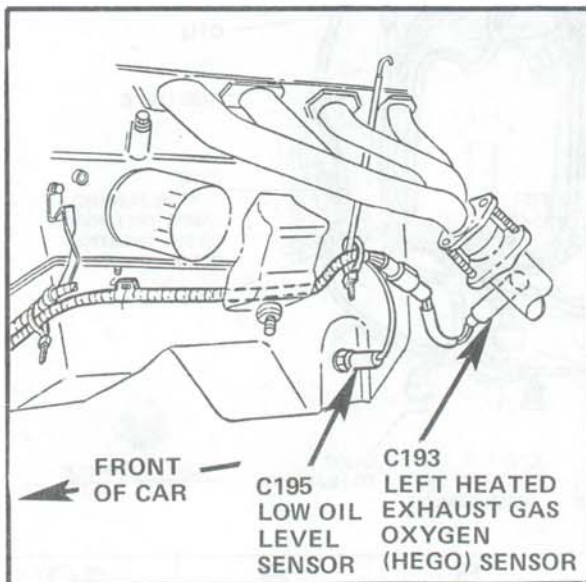

Figure 2 - Lower LH Side of 5.0L Engine

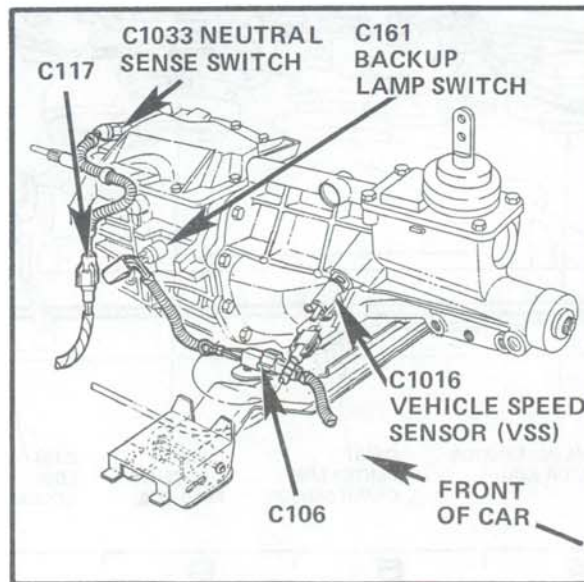

Figure 4 - LH Side of Manual Transmission (5.0L Shown; 2.3L Similar)

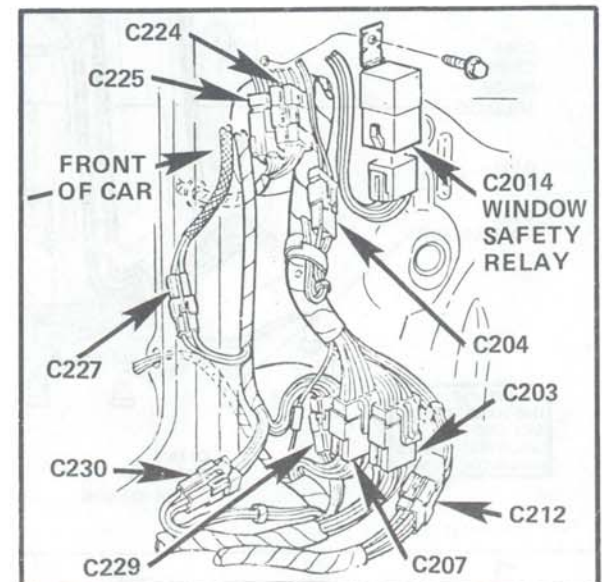

Figure 6 - Behind LH Cowl Panel (Convertible)

COMPONENT LOCATION VIEWS 151-6

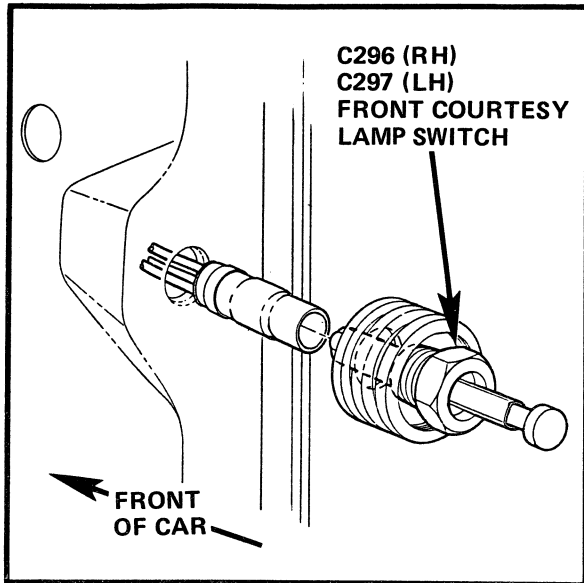

Figure 1 - Front of LH Door Jamb (RH Similar)

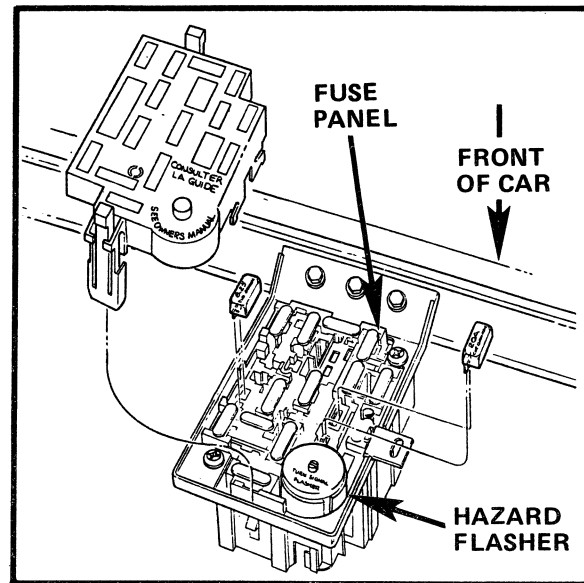

Figure 3 - Behind LH Side of I/P

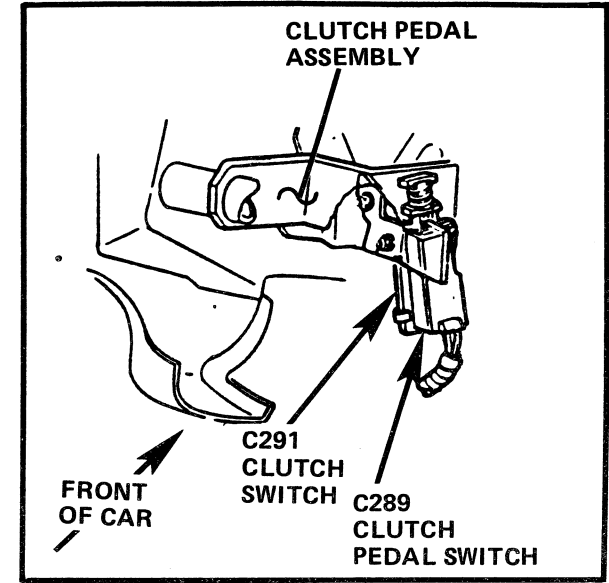

Figure 5 - Behind LH Side of I/P, on Clutch Pedal Support

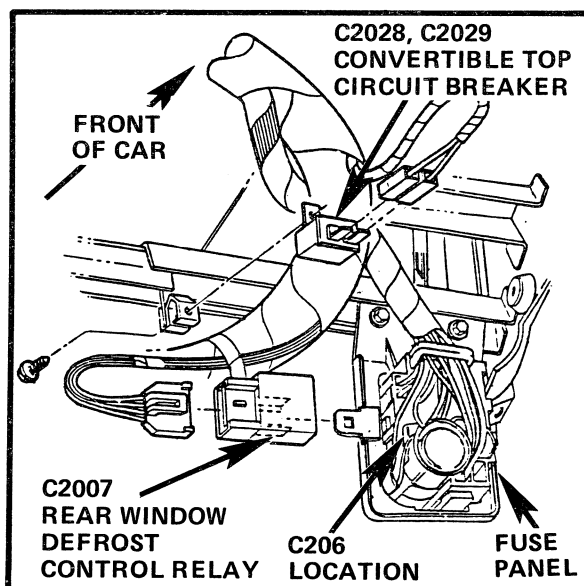

Figure 4 - Behind LH Side of I/P

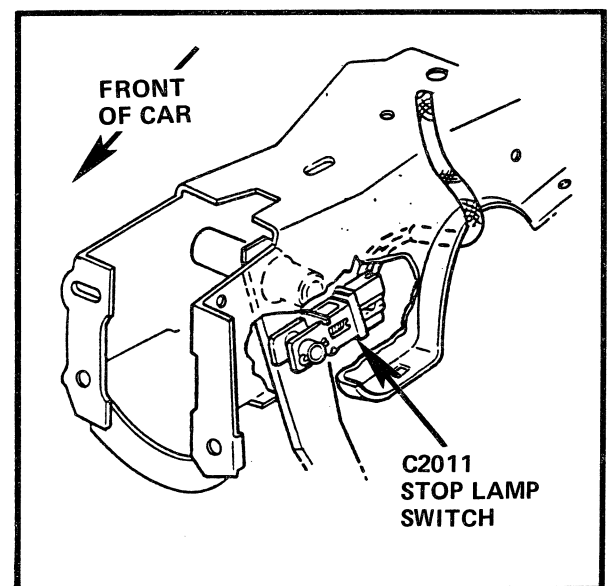

Figure 6 - Behind LH Side of I/P, on Brake Pedal Support

100% SATISFACTION GUARANTEED

BUY IT NOW!

Click Here To Order

Panel

PayPal American Express Cards DISCOVER NOVUS MasterCard VISA

151-7 COMPONENT LOCATION VIEWS

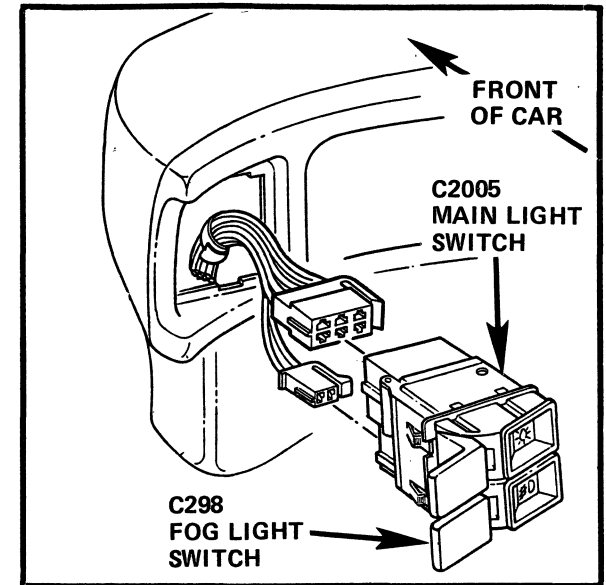
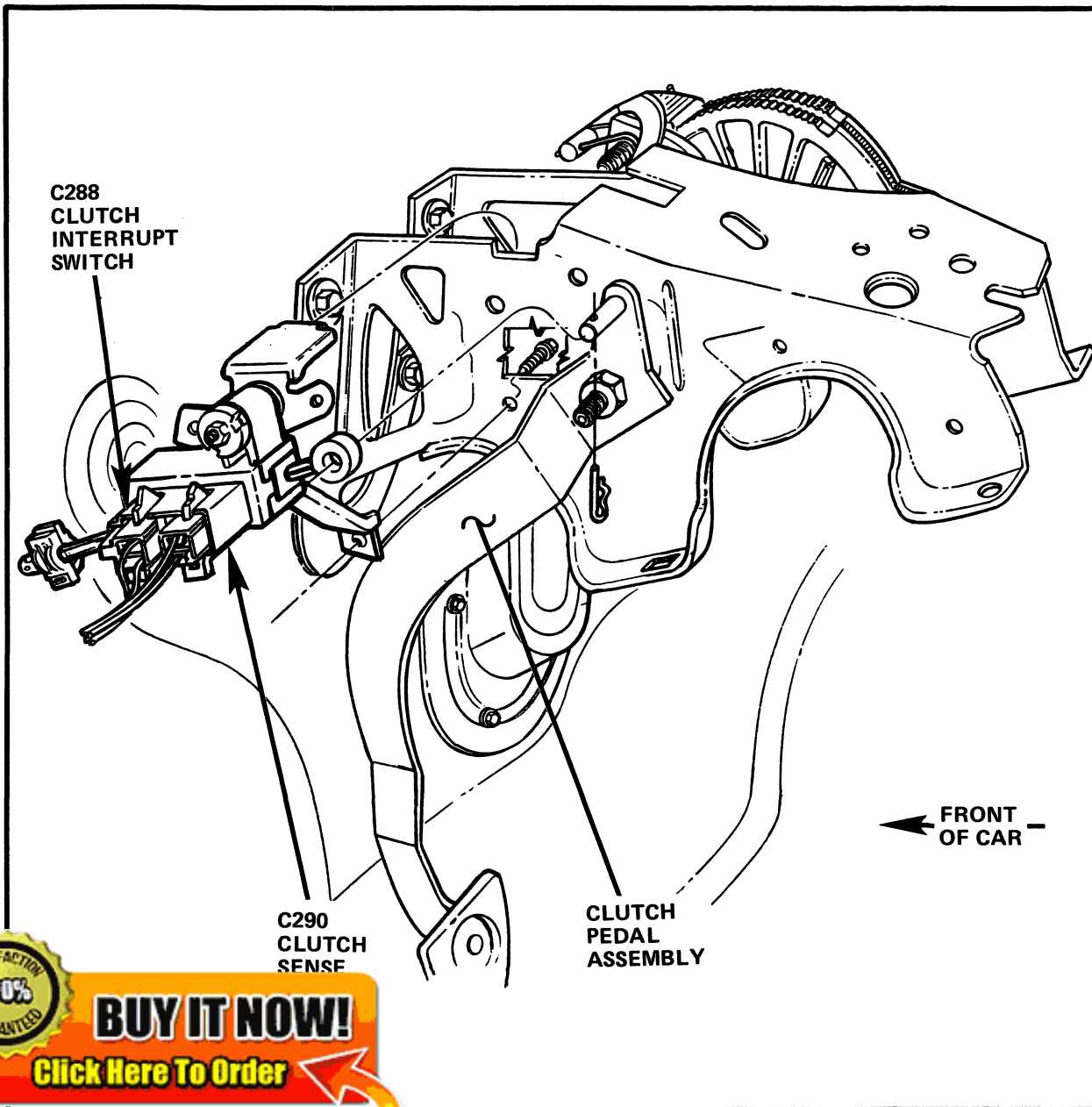

Figure 2 - LH Side of I/P, LH Side of Instrument Cluster

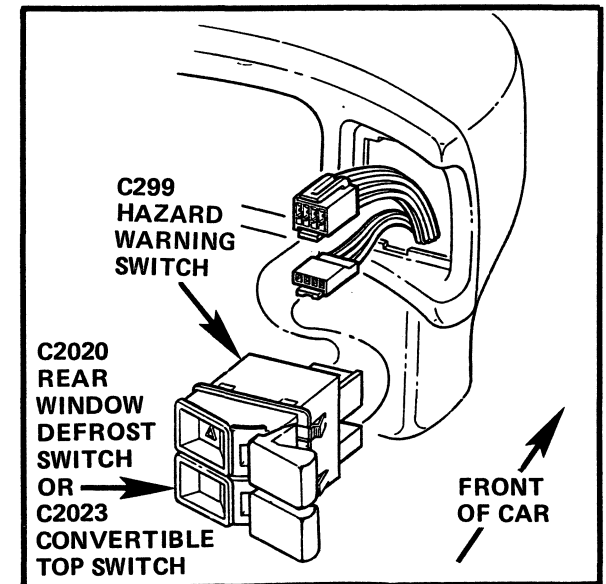

Figure 3 - LH Side of I/P, RH Side of Instrument Cluster

100% SATISFACTION GUARANTEED

BUY IT NOW!

Click Here To Order

PayPal American Express Cards DISCOVER NOVUS MasterCard VISA

and LH Side of I/P, on Clutch Pedal Support

COMPONENT LOCATION VIEWS 151-8

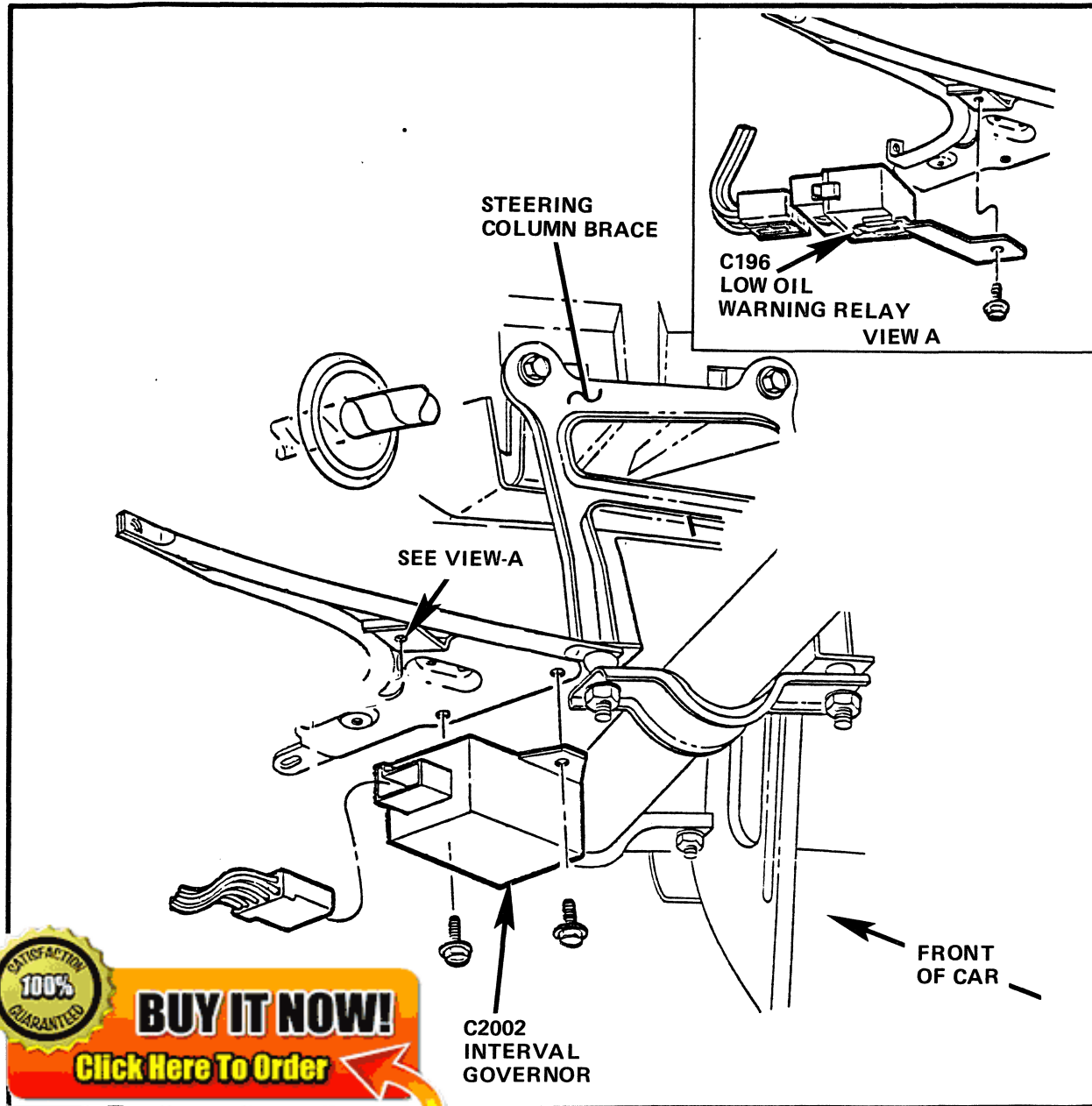

LH Side of I/P, near Steering Column Brace

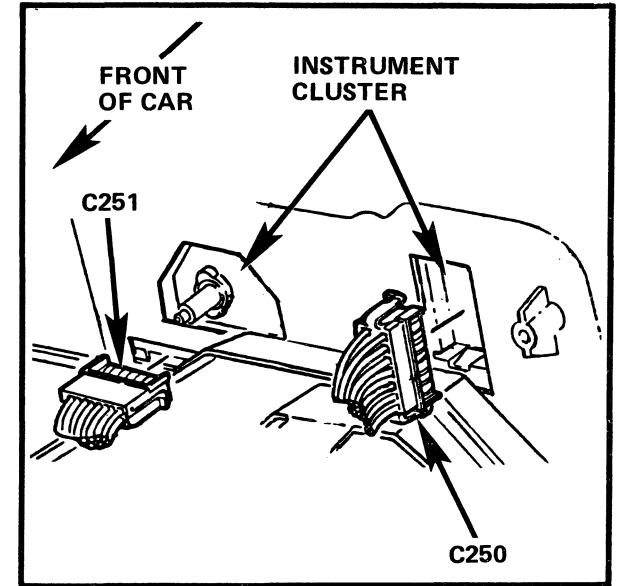

Figure 2 - Behind Top LH Side of I/P, on Rear of Instrument Cluster

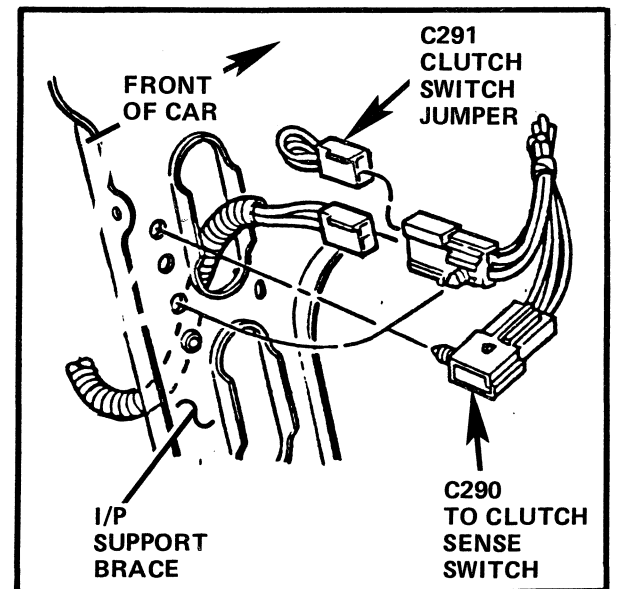

Figure 3 - Behind Center of I/P, near I/P Support Brace

100% SATISFACTION GUARANTEED

BUY IT NOW!

Click Here To Order

PayPal American Express Cards DISCOVER NOVUS MasterCard VISA

151-9 COMPONENT LOCATION VIEWS

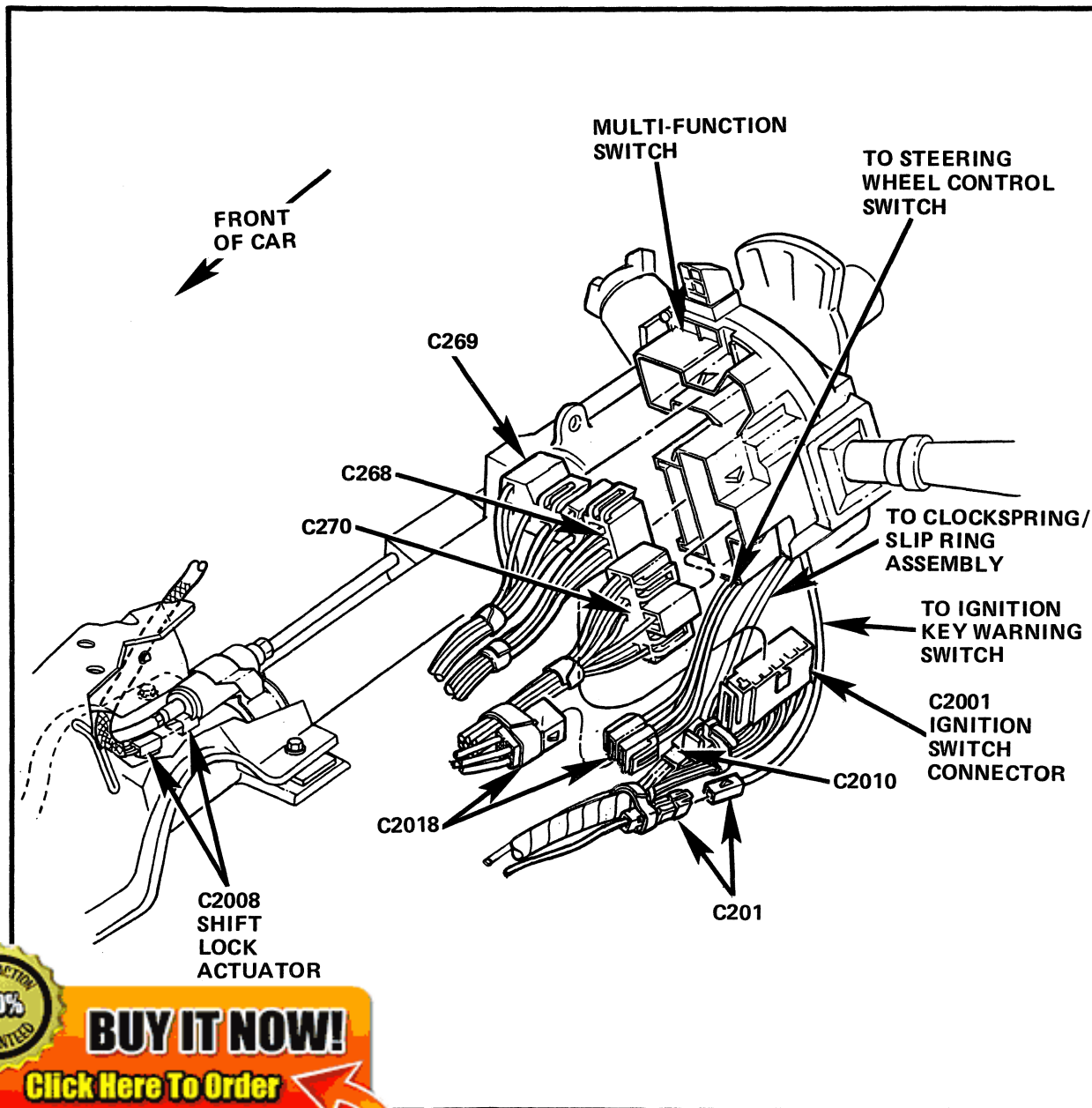

Figure 1 - Top of Steering Column

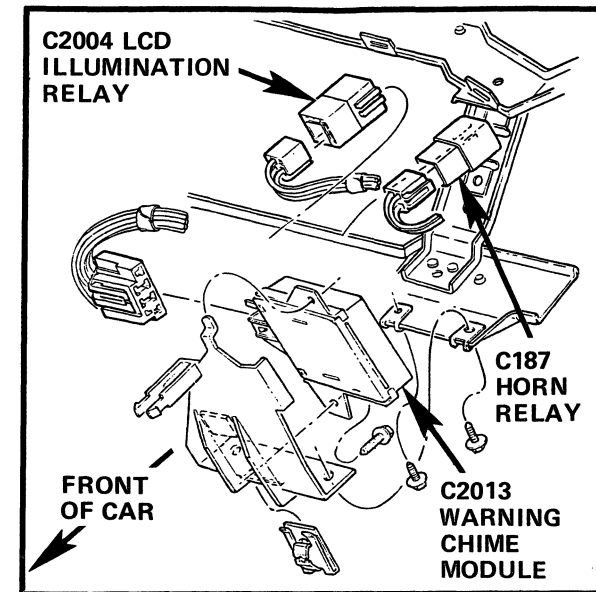

Figure 2 - Behind Center of I/P

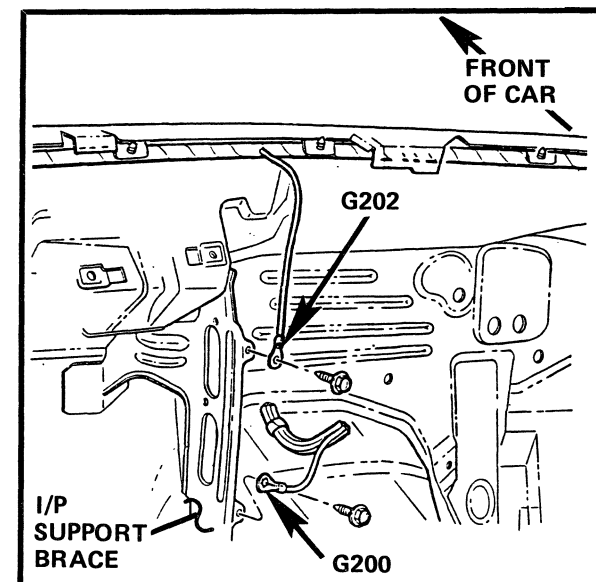

Figure 3 - Behind Center of I/P

100% SATISFACTION GUARANTEED

BUY IT NOW!

[Click Here To Order](#)

COMPONENT LOCATION VIEWS 151-10

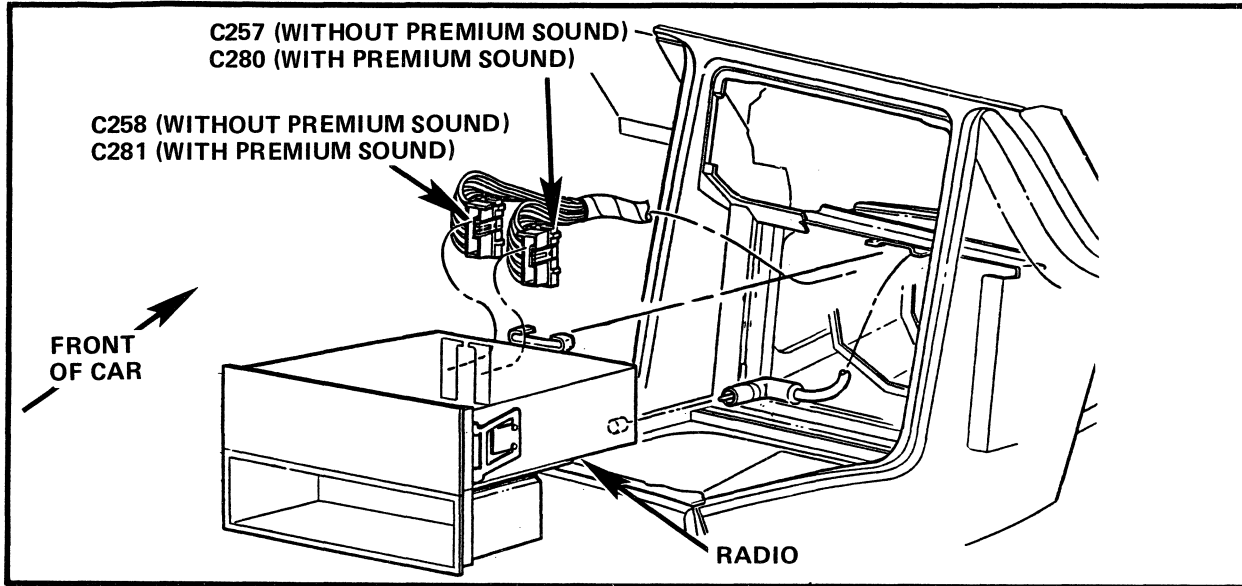

Figure 1 - Behind Center of I/P (Without Graphic Equalizer)

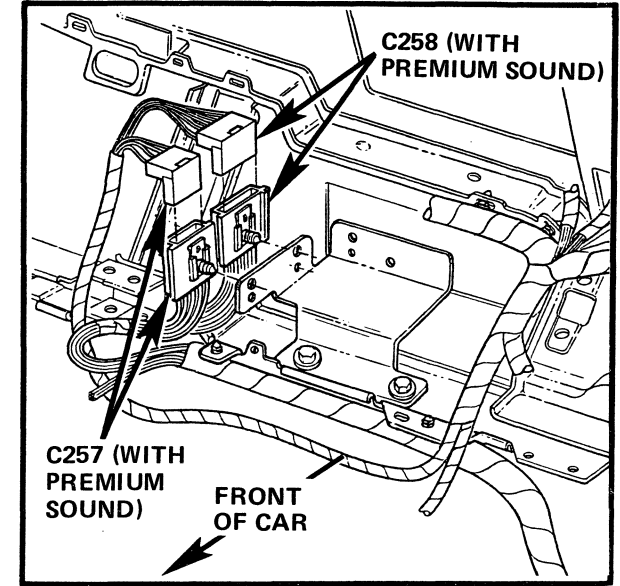

Figure 3 - Behind Center of I/P

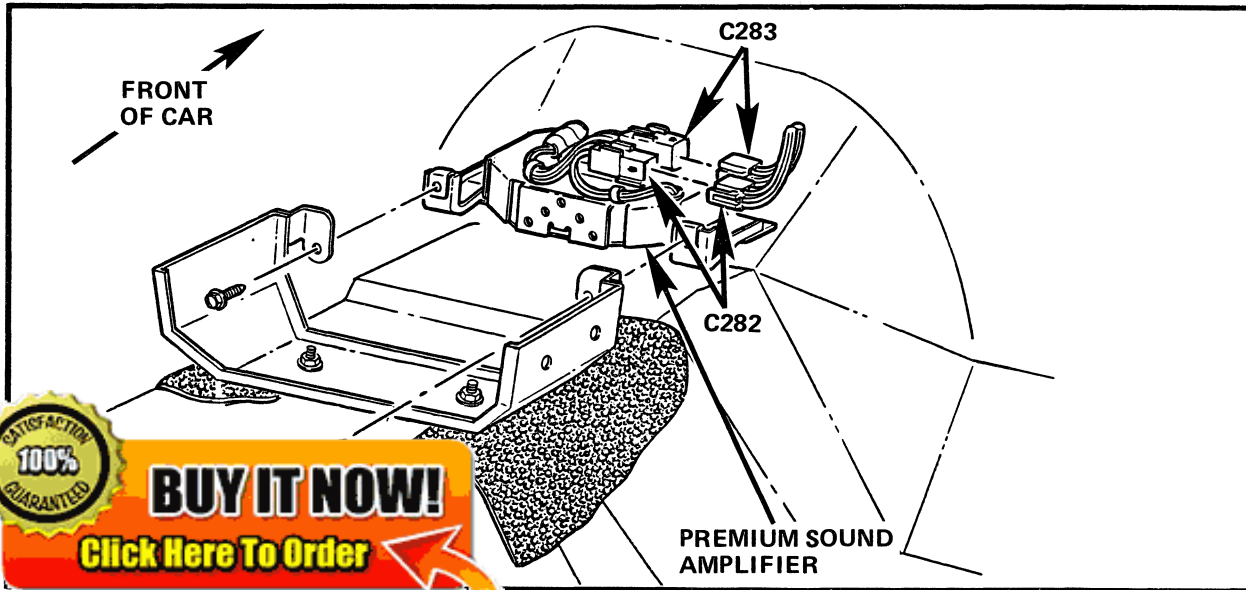

Figure 2 - Below Center Console

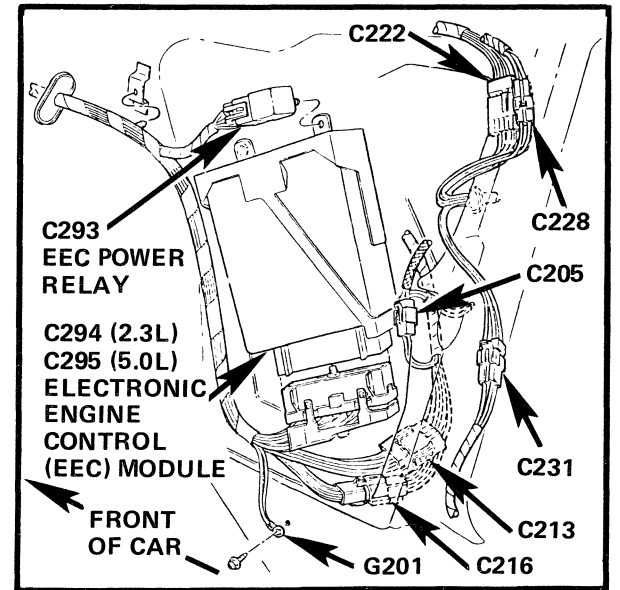

Figure 4 - Behind RH Cowl Panel

100% SATISFACTION GUARANTEED

BUY IT NOW!

[Click Here To Order](#)

151-11 COMPONENT LOCATION VIEWS

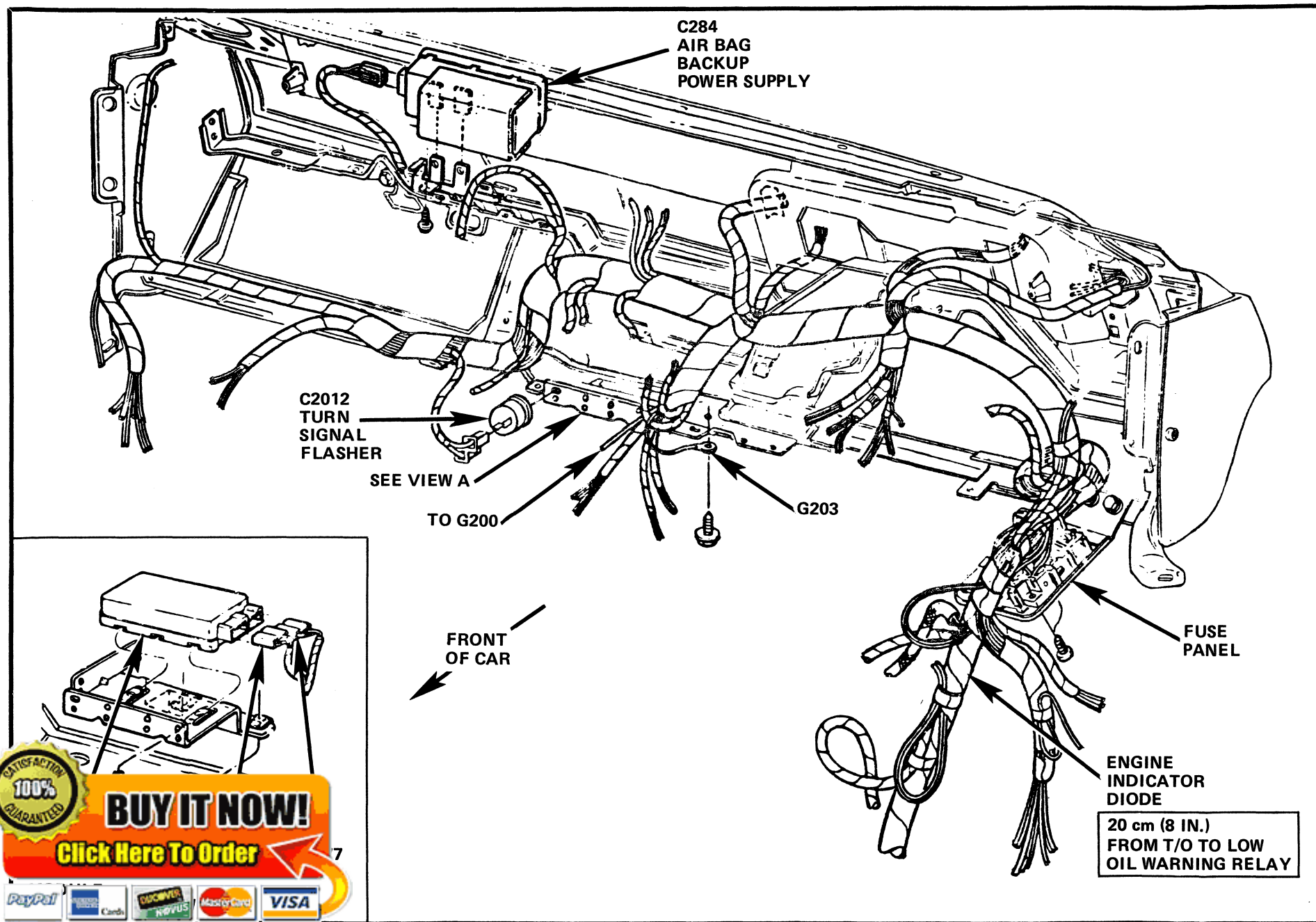

Figure 1 - Behind I/P

COMPONENT LOCATION VIEWS 151-12

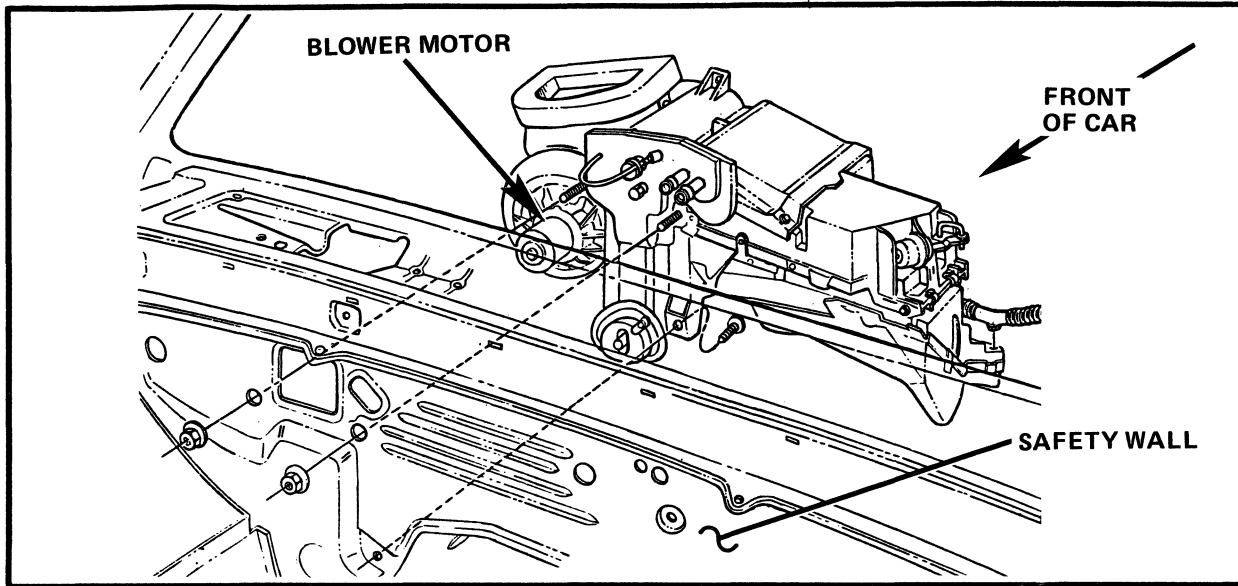

Figure 1 - Behind RH Side of Safety Wall

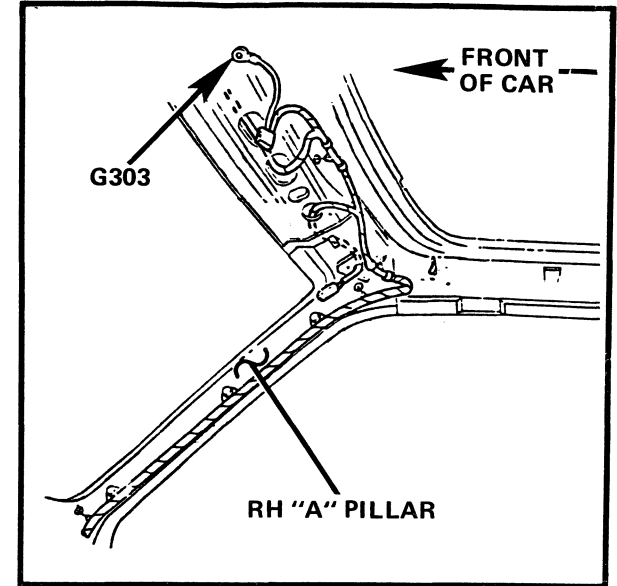

Figure 3 - Center of Windshield Header

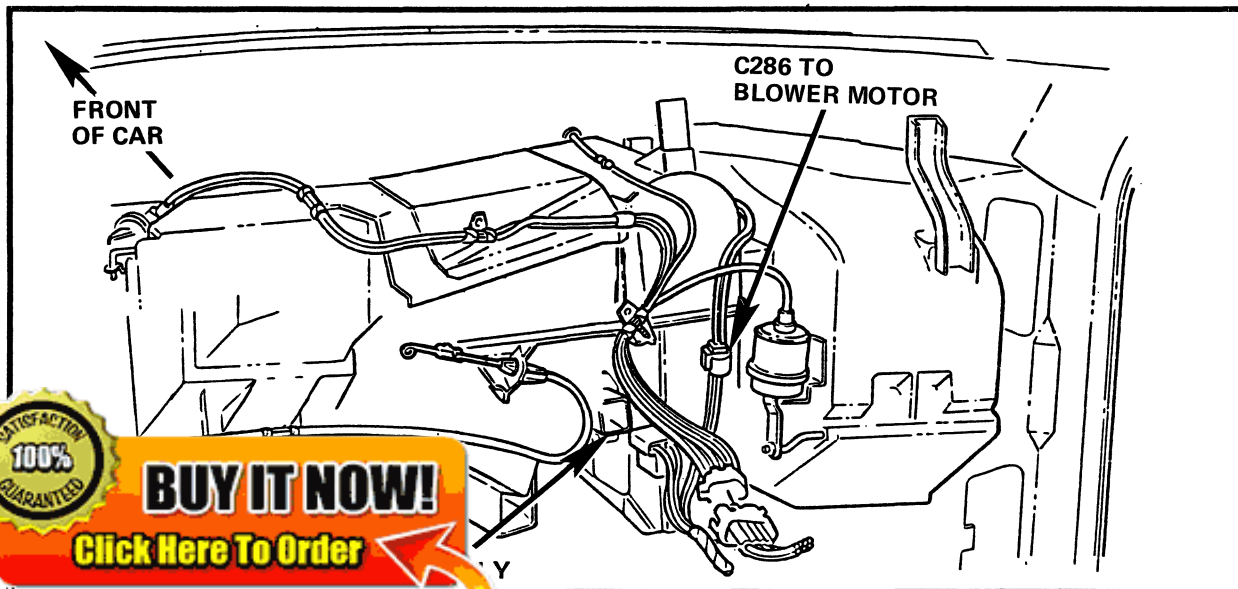

Figure 2 - Behind RH Side of I/P

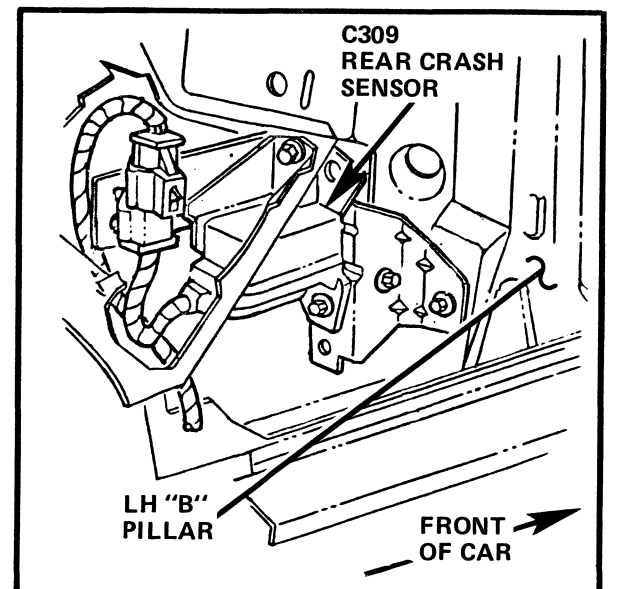

Figure 4 - Lower Front of LH Rear Quarter Panel

100% SATISFACTION GUARANTEED

BUY IT NOW!

[Click Here To Order](#)

PayPal American Express Discover MasterCard VISA

151-13 COMPONENT LOCATION VIEWS

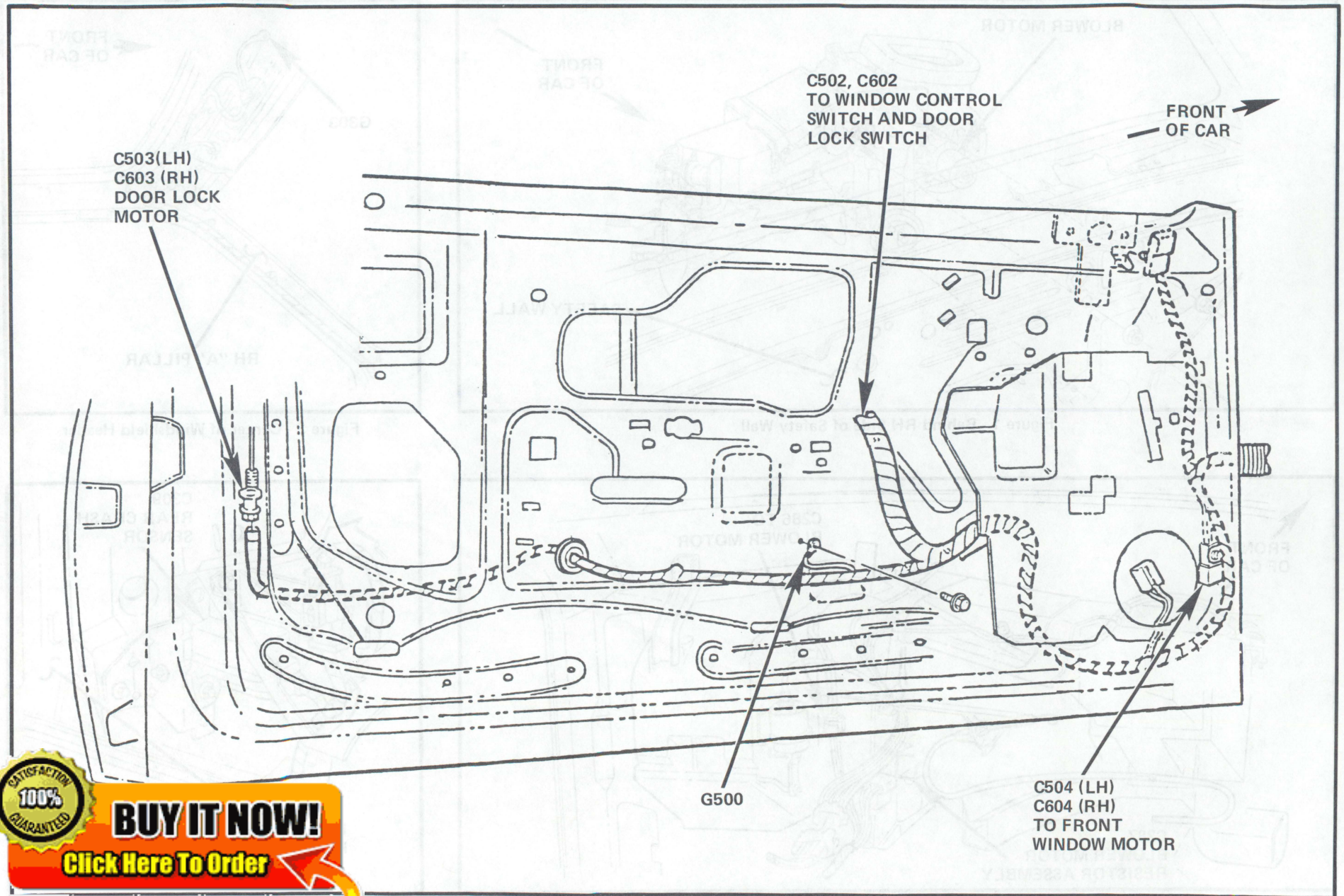

100% SATISFACTION GUARANTEED

BUY IT NOW!

Click Here To Order

PayPal
MasterCard
VISA

Figure 1 - In LH Door (RH Similar)

COMPONENT LOCATION VIEWS 151-14

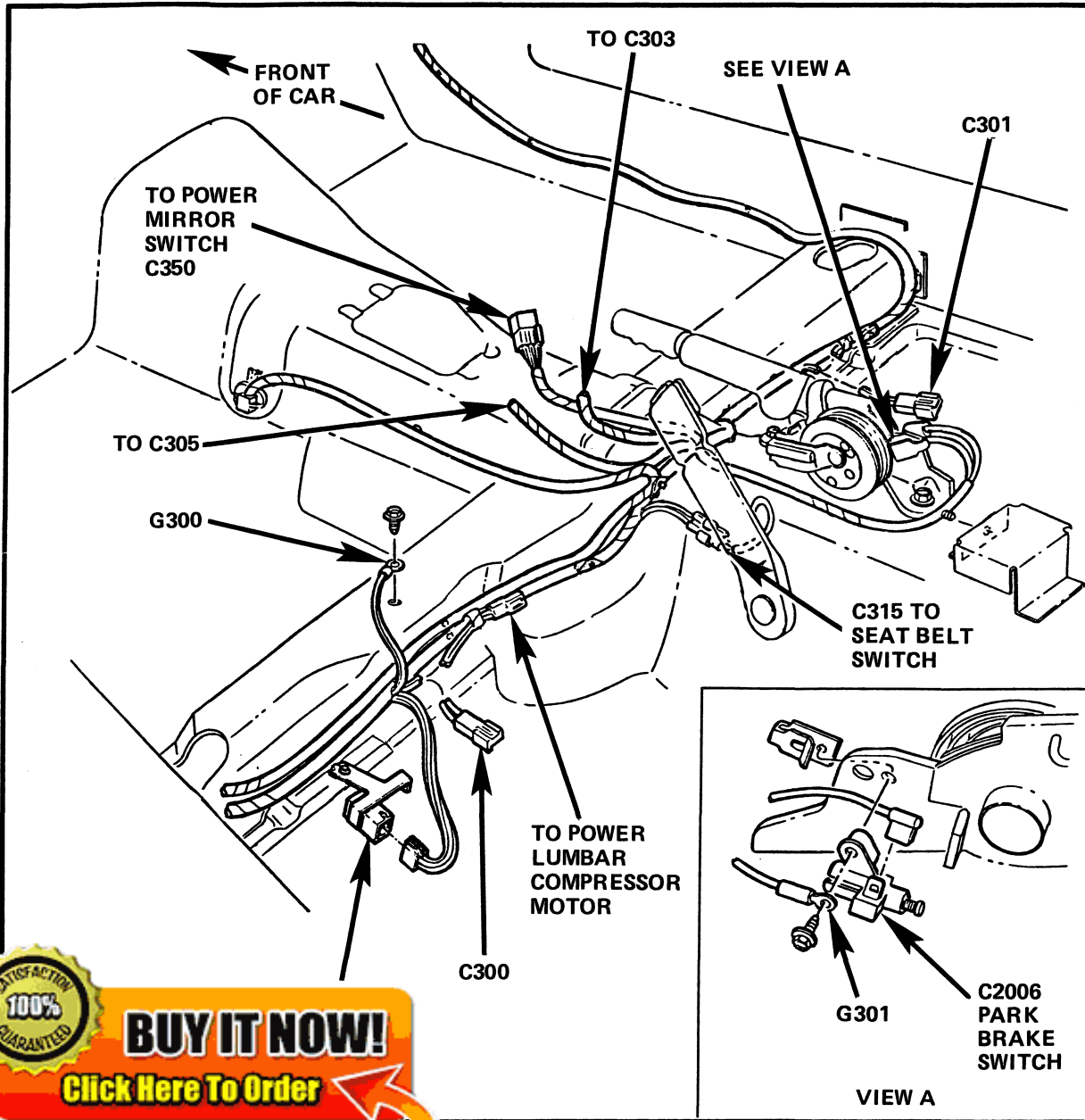

Figure 1 - Front of Floor Pan

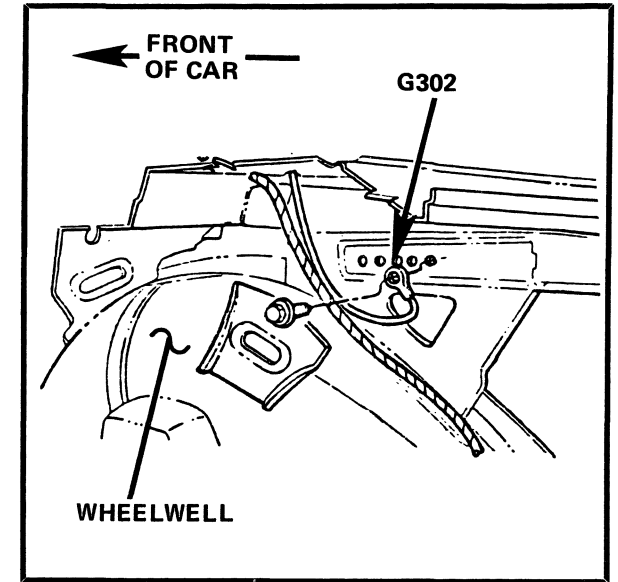

Figure 2 - RH Side of Trunk

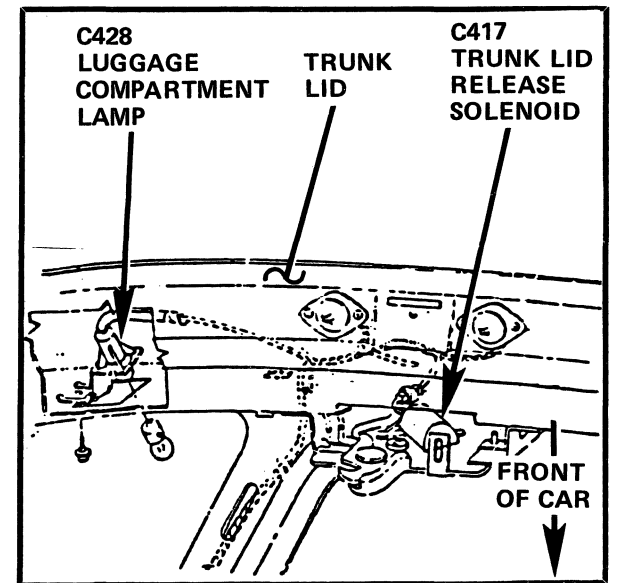

Figure 3 - Rear of Trunk Lid

100% SATISFACTION GUARANTEED

BUY IT NOW!

Click Here To Order

151-15 COMPONENT LOCATION VIEWS

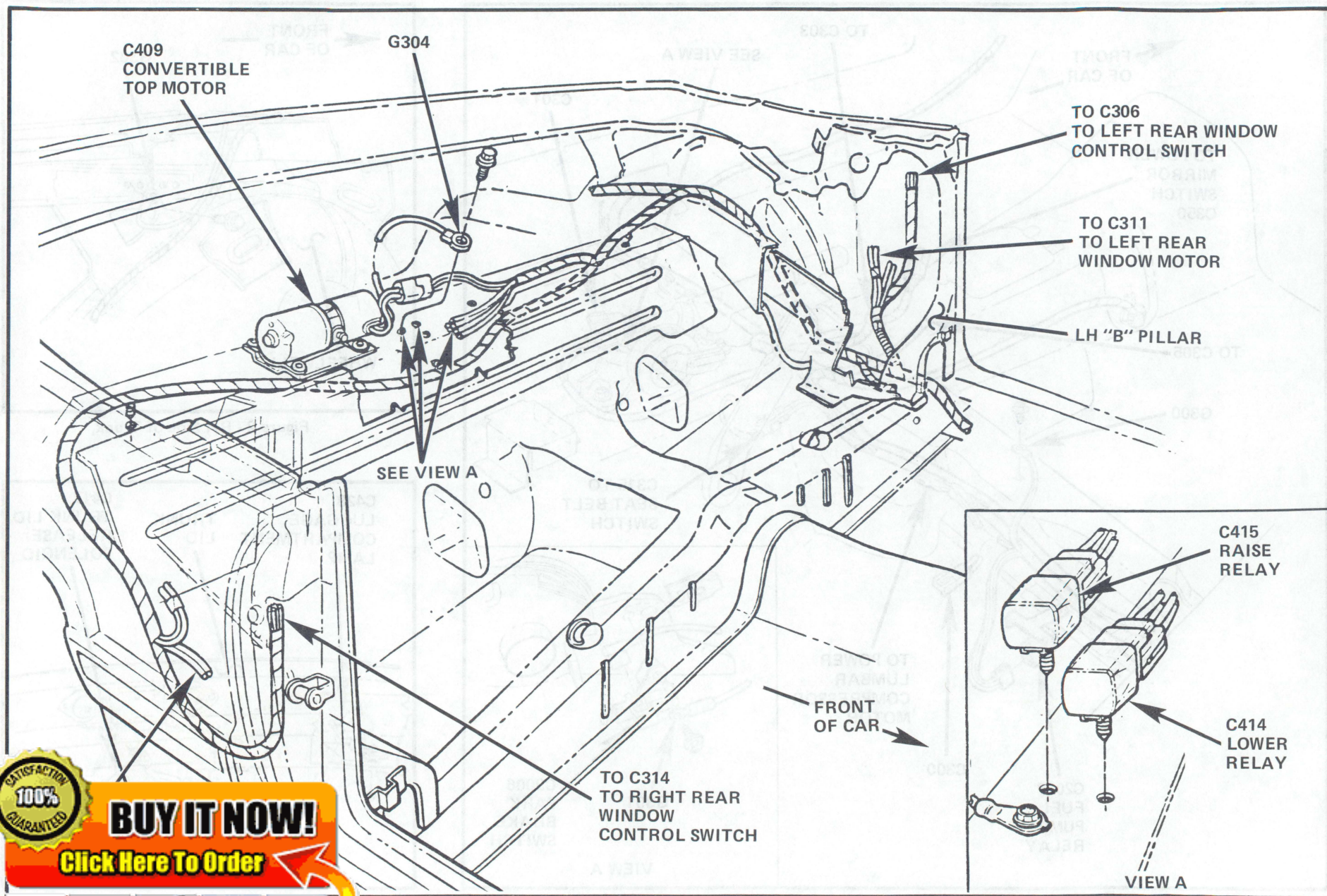

100% SATISFACTION GUARANTEED

BUY IT NOW!

[Click Here To Order](#)

PayPal | American Express | Discover | MasterCard | VISA

Figure 1 - Behind Center of Rear Seat

COMPONENT LOCATION VIEWS 151-16

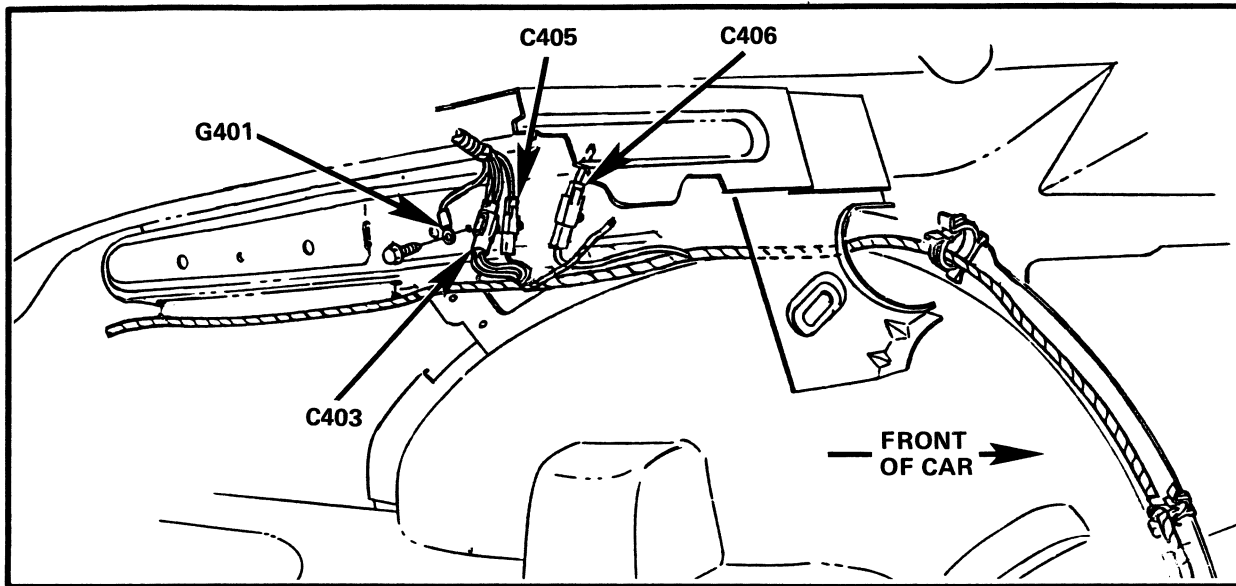

Figure 1 - LH Side of Trunk

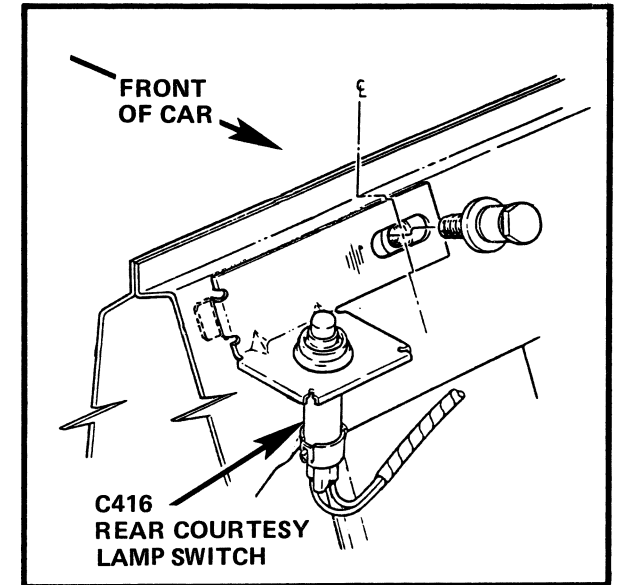

Figure 3 - Center Rear of Cargo Area

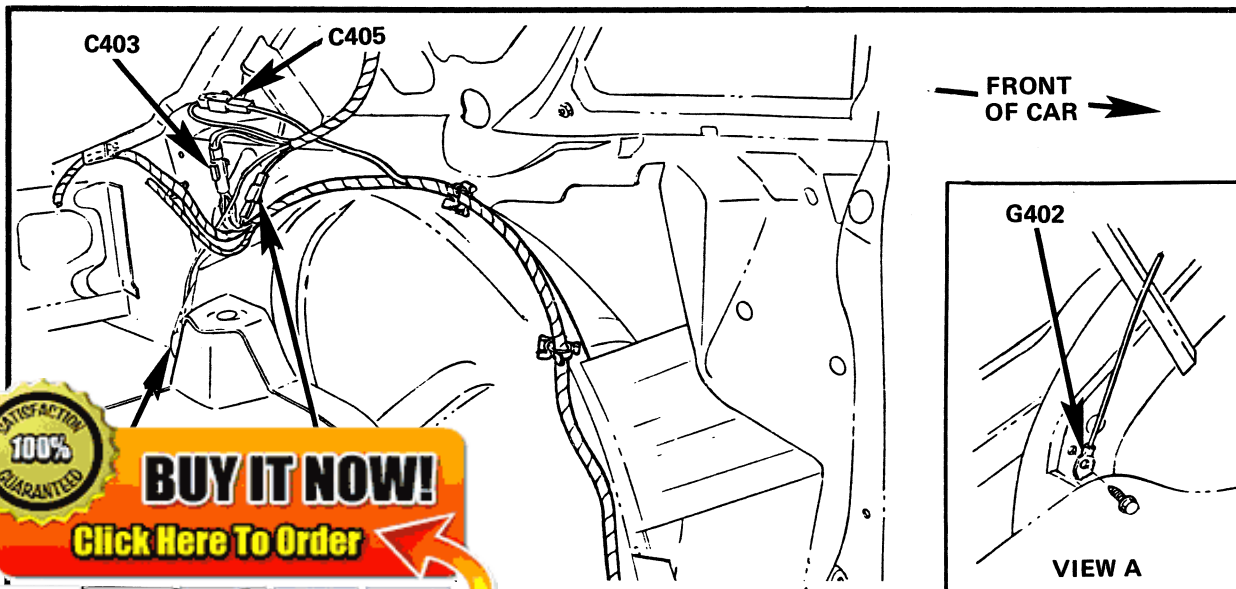

Figure 2 - LH Side of Cargo Area

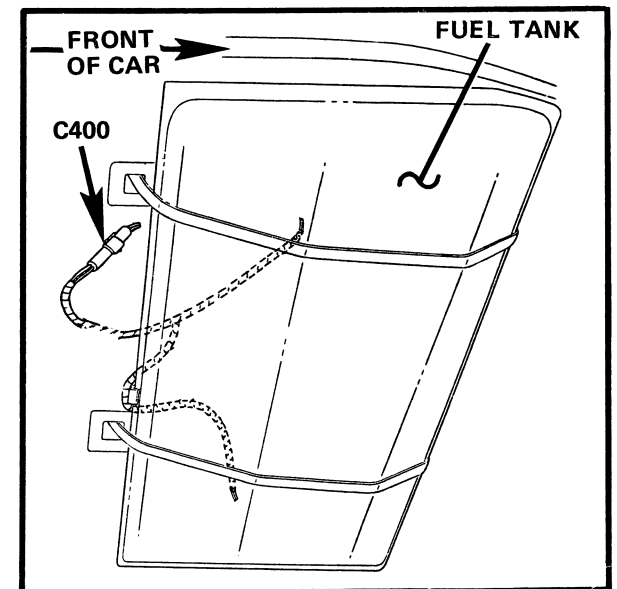

Figure 4 - Below Rear of Car

100% SATISFACTION GUARANTEED

BUY IT NOW!

Click Here To Order

PayPal American Express Discover MasterCard VISA

151-17 COMPONENT LOCATION VIEWS

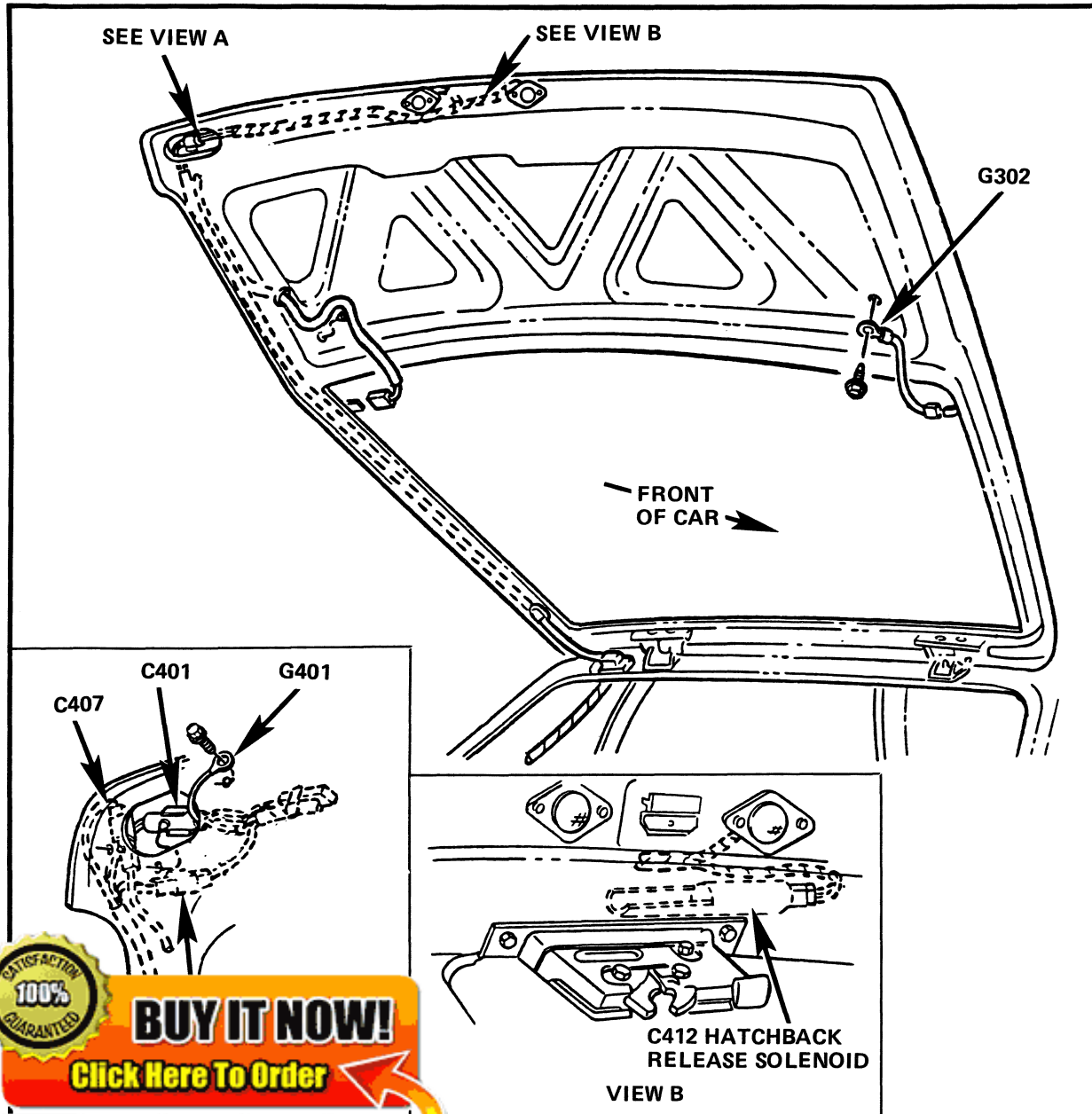

Figure 1 - Rear of Hatchback

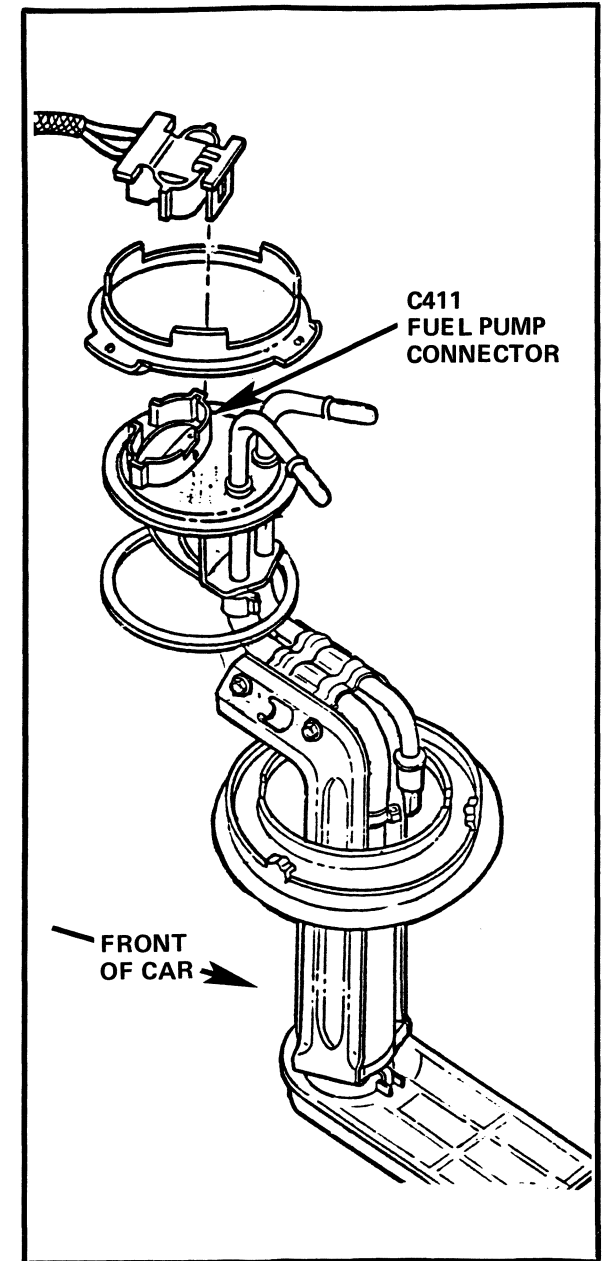

Figure 2 - Below Rear of Car, on RH Side of Fuel Tank

100% SATISFACTION GUARANTEED

BUY IT NOW!

[Click Here To Order](#)

COMPONENT LOCATION VIEWS 151-18

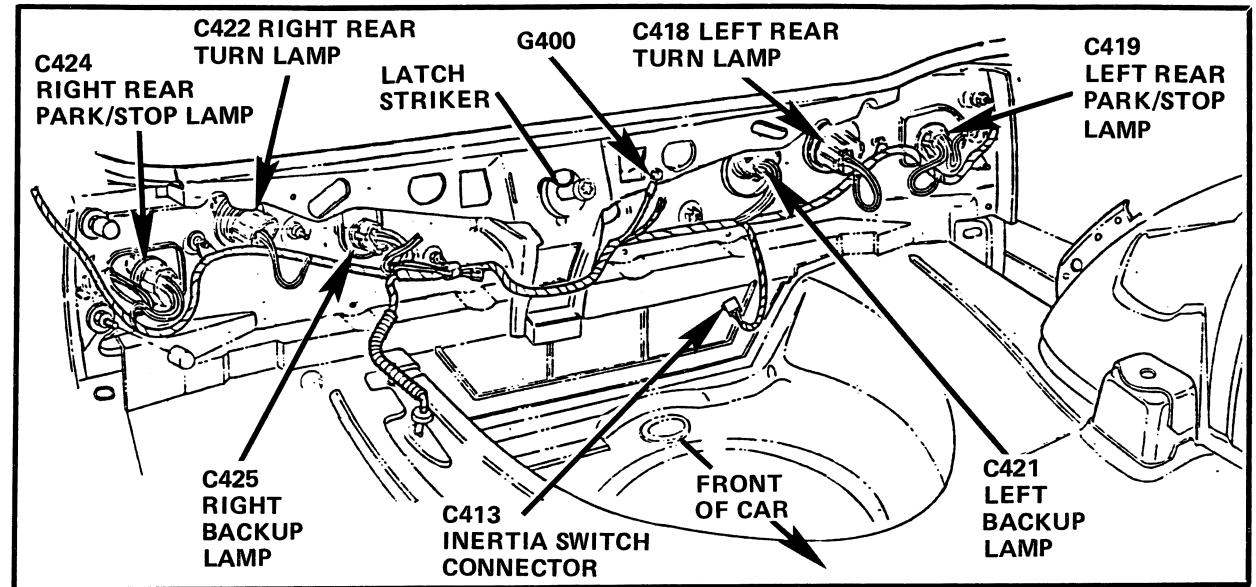
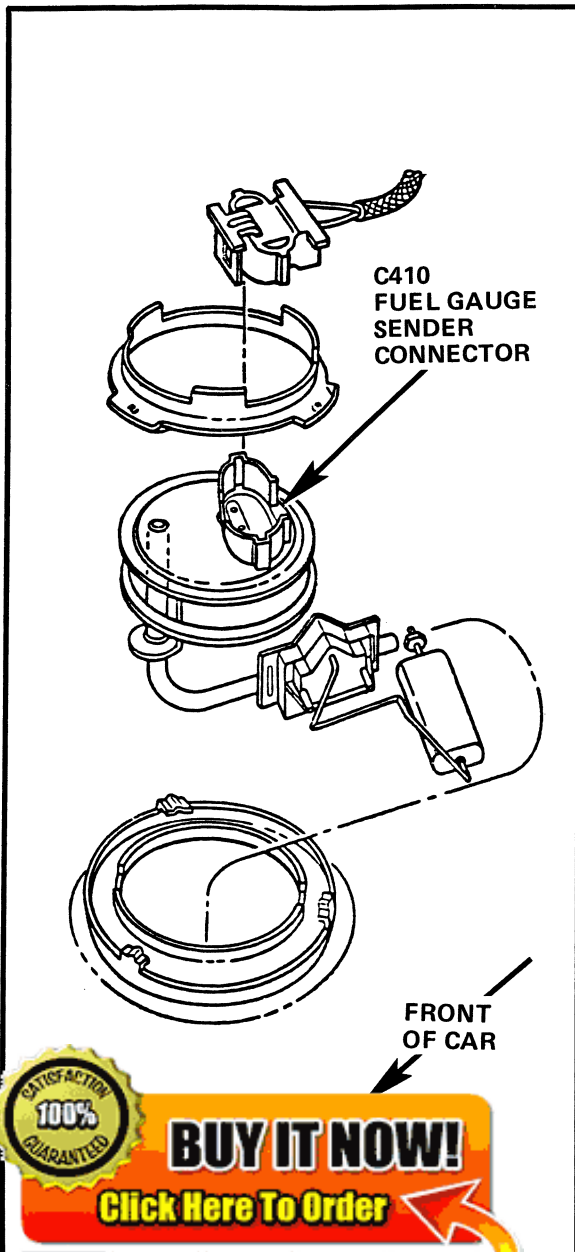

Figure 2 - Rear of Trunk (2 Door Shown; 3 Door Similar)

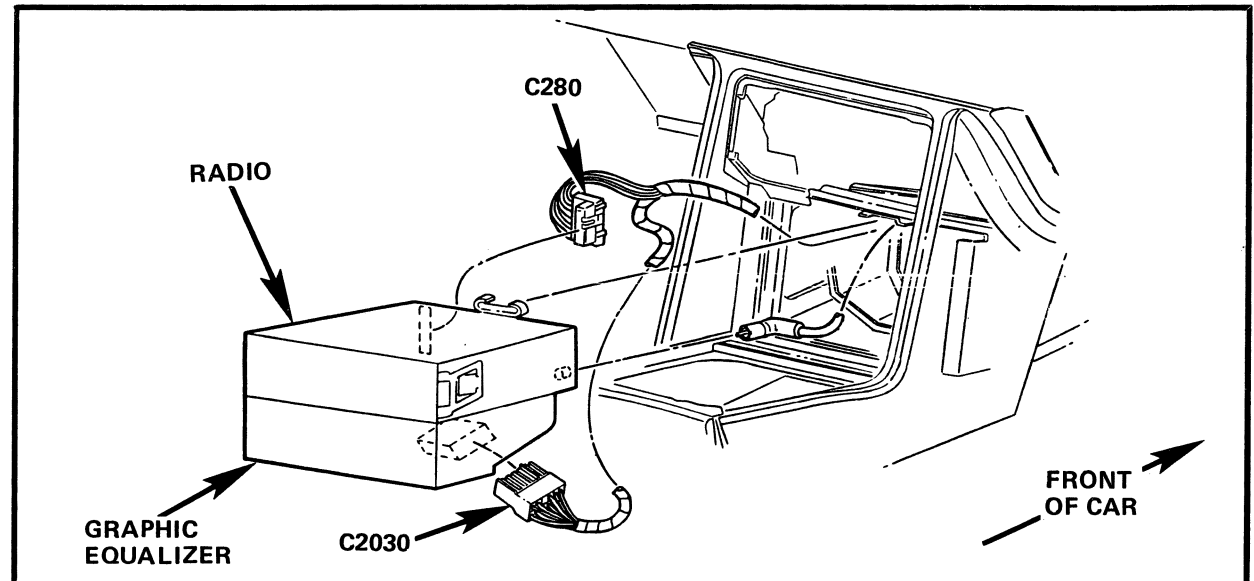

Figure 3 - Behind Center of I/P (With Graphic Equalizer)

100% GUARANTEED

BUY IT NOW!

Click Here To Order

Fi Tank

152-1 LOCATION INDEX

<u>Base Harness Number</u>	<u>Harness Name</u>	<u>Major Systems</u>
6B018	Engine Block Heater	Engine Block Heater
7C078	Transmission Control Neutral Switch	Backup Lamps
7E443	Transmission Control Switch	Speed Control, Vehicle Speed Sensor
9A340	Fuel Pump Feed Jumper	Fuel Pump, Fuel Gauge
9D930	Fuel Charging	Engine Controls, Engine Sensors
12A581	Engine Control Sensor	Air Conditioner Air Bag Restraint Engine Controls Starting Ignition
12A690	Engine Control Sensor Extension	Engine Controls
12638	Starter Circuit Jumper	Starting System
13412	Rear License Lamp	Hi Mount Stop Lamp License Lamp
13B440	Rear License Lamp Feed	License Lamp
14024	Front Door Lock (RH)	Radio Right Front Power Door Locks
14025	Front Door Lock (LH)	Left Front Power Door Locks Power Mirrors Radio
14290	Dash Panel To Headlamps	Alternator Cooling Fan Fog Lamps Front Side Marker Lamps Front Park/Turn Lamps Headlamps Horns Starter Relay
14334	Interior Lamp Feed	Courtesy Lamps
14335	Interior Lamp	Courtesy Lamps
	Main	Air Conditioner/Heater Air Bag Restraint Convertible Top Daytime Running Lamps Defrost Switch Fog Lamps Fuse Panel



BUY IT NOW!
Click Here To Order 







LOCATION INDEX 152-2

<u>Base Harness Number</u>	<u>Harness Name</u>	<u>Major Systems</u>
		Headlamps Horn Instrument Cluster Radio Rear Window Speed Control Starting Ignition Turn/Stop/Hazard Lamps Warning Chimes Windshield Wipers
14405	Rear Harness	Air Bag Rear Crash Sensor Backup Lamps Control Switches Convertible Top Fuel Pump Inertia Switch Fuel Pump Relay Hi Mount Stop Lamps Left Courtesy Lamp Switch Marker Lamps Power Mirrors Radio Rear Window Turn/Stop/Hazard Lamps
14630	Right Front Window Regulator	Power Door Locks Radio
14631	Left Front Window Regulator	Power Door Locks Power Mirrors Power Windows
14A220	Window Regulator Relay Switch	Power Windows
	Window Regulator Right Front Door	Power Door Locks Power Windows Ashtray Illumination Cigar Lighter
14	Lumbar Seats
14 Front Door	Power Door Locks Power Windows

100% SATISFACTION GUARANTEED

BUY IT NOW!

Click Here To Order



152-3 LOCATION INDEX

<u>Base Harness Number</u>	<u>Harness Name</u>	<u>Major Systems</u>
15525	Backup Lp Sw To Rear Lamp Feed	Backup Lamps
15A702	Engine Compartment Lamp Feed	Courtesy Lamps
18C618	Back Window Heater	Rear Window Defrost
18C619	Back Window Heater	Rear Window Defrost
18C620	Back Window Ground	Rear Window Defrost
19A044	Radio Speaker Front (LH)	Power Mirrors Radio
19A170	Radio Speaker Jumper	Radio
19B113	Graphic Equalizer	Radio
19B516	Luggage Compartment Lamp	Hi Mount Stop Lamp License Lamp Trunk Lid Release
19D887	Air Conditioning Jumper	Air Conditioner/Heater



BUY IT NOW!
Click Here To Order 



LOCATION INDEX 152-4

	<u>Connector</u>	<u>Base Part No.</u>	<u>Location</u>	<u>Page Figure/Zone</u>	<u>Connector Page</u>
ension	C157		Under center of car, behind engine	151- 5-3	
de (2.3L)		19B618 ...	RH side of engine compartment, taped to engine harness	151- 1-C1	
de (5.0L)		19B618 ...	LH side of engine compartment, taped to air condition jumper harness	*	
d Coil (2.3L)	C159	2A987	Lower RH front of engine, part of A/C compressor assembly	151- 2-F3	
Clutch Field Coil (5.0L)	C159	2A987	Top LH front of engine, part of A/C compressor assembly	151- 4-F6	
A/C-Heater Control Assembly	C285		Center of I/P	*	
A/C-Heater Control Illumination	C2017		Center of I/P, on A/C-heater control assembly ..	*	
Air Bag Backup Power Supply	C284	14B165 ...	Behind RH side of I/P, above glove box	151- 11-1	150- 2
Air Bag Diagnostic Module	C276, C277 ..	14B056 ...	Behind center of I/P	151- 11-1	150- 1
Air Charge Temperature (ACT)					
Sensor (2.3L)	C160	12A697 ...	RH side of engine, near air cleaner assembly ...	151- 2-D1	
Air Charge Temperature (ACT)					
Sensor (5.0L)	C160	12A697 ...	Top center of engine, behind coolant temperature sender	151- 3-F6	
Ashtray Illumination	C319		Center console	*	
Backup Lamp Switch	C161	15520	LH side of manual transmission	151- 5-4	
Backup Lamps	C421, C425 ..		Respective rear sides of car	151- 12-2	
Backup/Neutral Safety Switch	C162	7A247	LH side of automatic transmission	151- 5-3	
Barometric Absolute Pressure					
(BAP) Sensor (2.3L)	C163	12A680 ...	Center of safety wall	151- 1-A5	
Barometric Absolute Pressure					
(BAP) Sensor (5.0L)	C163	12A680 ...	Center of safety wall	151- 4-A5	
Blower Motor	C286	19805	Behind RH side of I/P	151- 12-1	
Blower Motor Resistor Assembly	C287	19A706 ...	Behind RH side of I/P, in A/C-heater assembly ..	151- 12-2	
Blower Motor Switch	C2015		Center of I/P	*	
Brake Fluid Level Switch (2.3L)	C164	2B264	LH rear of engine compartment, on brake fluid reservoir	151- 1-A9	
Brake Fluid Level Switch (5.0L)	C164	2B264	LH rear of engine compartment, on brake fluid reservoir	151- 3-B9	

* No Figure Available

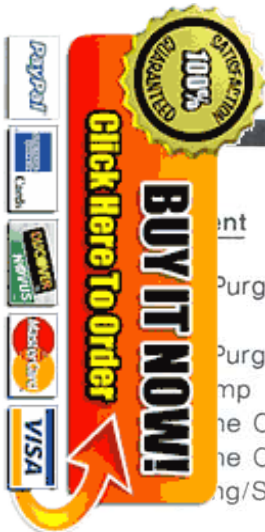

LOCATION INDEX

Component	Connector	Base Part No.	Location	Page Figure/Zone	Connector Page
Purge Solenoid (2.3L)	C1032	9C915	RH side of engine compartment, forward of shock tower	151- 2-D1	
Purge Solenoid (5.0L)	C165	9C915	Lower RH side of engine	151- 4-D1	
Temp	C429		Center rear of cargo area	*	
Crash Sensor (2.3L)	C166	14B006	Top center of upper radiator support	151- 1-F5	
Crash Sensor (5.0L)	C166	14B006	Top center of upper radiator support	151- 4-F5	
Steering/Slip Ring Assembly	C2010	14A664	In top of steering column, behind steering column air bag	151- 9-1	
Clutch Cycling Pressure Switch (2.3L)	C167	19E561	RH rear corner of engine compartment, on A/C accumulator	151- 2-A1	
Clutch Cycling Pressure Switch (5.0L)	C167	19E561	RH rear corner of engine compartment, on A/C accumulator	151- 4-A2	
Clutch Interrupt Switch	C288		Behind LH side of I/P, on clutch pedal support	151- 7-1	
Clutch Pedal Switch	C289		Behind LH side of I/P, on clutch pedal support	151- 6-5	
Clutch Sense Switch	C290		Behind LH side of I/P, on clutch pedal support	151- 7-1	
Clutch Switch	C291		Behind LH side of I/P, on clutch pedal support	151- 6-5	
Clutch Switch Jumper	C291		Behind center of I/P, on I/P support brace	151- 8-3	
Convertible Top Circuit Breaker	C2028, C2029	14526	Behind LH side of I/P, RH side of fuse panel	151- 6-4	
Convertible Top Motor	C409		Behind center of rear seat	151- 15-1	
Convertible Top Switch	C2023		LH side of I/P, right of instrument cluster	151- 7-3	
Coolant Temperature Sender (2.3L)	C168	10884	Lower LH side of engine, below oil pressure switch	*	
Coolant Temperature Sender (5.0L)	C168	10884	Top center front of engine, LH side of distributor	151- 3-F4	
Crankshaft Position Sensor	C111, C112	6300/ 6C315	LH front of engine, near bottom of intake manifold	151- 2-F5	150- 4
Dash Speakers	C2024, C2025		Respective sides of I/P	*	
Daytime Running Lamps (DRL) Module (2.3L)	C170	15A272	In front of LH fender, below horns	151- 1-E9	150- 4
Daytime Running Lamps (DRL) Module (5.0L)	C170	15A272	In front of LH fender, below horns	151- 4-E9	150- 4

* No Figure Available

LOCATION INDEX 152-6

<u>Component</u>	<u>Connector</u>	<u>Base Part No.</u>	<u>Location</u>	<u>Page Figure/Zone</u>	<u>Connector Page</u>
Distributorless Ignition System (DIS) Module	C155, C156		LH front of engine, forward of intake manifold	151- 1-F7	150- 3
Dome Lamp (With Moonroof)	C326		Forward center of roof	*	
Dome Lamp (Without Moonroof)	C327		Forward center of roof	*	
Door Lock Motors	C503, C603	14A626	In rear of respective doors	151- 13-1	
Door Lock Switches (With Power Windows)	C502, C602	14028	Center of respective doors, part of window control switch	151- 13-1	150- 22
Door Lock Switches (Without Power Windows)	C507, C606	14028	Center of respective doors	*	
Door Speakers	C508, C607		In front of respective doors	*	
DRL Shorting Connector (2.3L)	C170	14A624	In front of LH fender, below horns	151- 1-E9	
DRL Shorting Connector (5.0L)	C170	14A624	In front of LH fender, below horns	151- 4-E9	
EEC Power Relay (5.0L)	C293	12A646	Behind RH cowl panel, above electronic engine control (EEC) module	151- 10-4	150- 4
EGR Vacuum Regulator Solenoid (2.3L)	C171	9D460	RH rear of engine compartment, on rear of shock tower	151- 2- B1	
EGR Vacuum Regulator Solenoid (5.0L)	C171	9D460	RH rear of engine compartment, on rear of shock tower	151- 4-B1	
EGR Valve Position Sensor (2.3L)	C172	9G428	Top LH rear of engine, on rear of intake manifold	151- 2-A5	
EGR Valve Position Sensor (5.0L)	C172	9G428	Top RH side of engine, on rear of intake manifold	151- 3-A3	
Electric Cooling Fan	C173	8K620	Center front of engine compartment, behind radiator	151- 2-F4	
Electronic Engine Control (EEC) Module (2.3L)	C294	12A650	Behind RH cowl panel	151- 10-4	150- 5
Electronic Engine Control Module (5.0L)	C295	12A650	Behind RH cowl panel	151- 10-4	150- 7
	C158		Underside of hood	151- 5-1	
	C174	12A648	RH rear of engine, below intake manifold	151- 2-A2	

100% SATISFACTION GUARANTEED

BUY IT NOW!

Click Here To Order

★

152-7 LOCATION INDEX

<u>Component</u>	<u>Connector</u>	<u>Base Part No.</u>	<u>Location</u>	<u>Page Figure/Zone</u>	<u>Connector Page</u>
Engine Coolant Temperature (ECT) Sensor (5.0L)	C174	12A648	Top RH front of engine, RH side of front fuel injector	151- 3-D1	
Engine Indicator Diode		10C912	Behind LH side of I/P, taped in main harness	151- 11-1	
Fog Lamp Switch	C298		LH side of I/P, left of instrument cluster	151- 7-2	
Fog Lamps	C1021, C1025		Center front of car	151- 3-F8	
Forward Crash Sensors (2.3L)	C176, C177	14B004-7	Respective sides of upper radiator support, behind headlamp	151- 1-F8	
Forward Crash Sensors (5.0L)	C176, C177	14B004-7	Respective sides of upper radiator support, behind headlamp	151- 4-F3	
Front Courtesy Lamp Switches	C296, C297	13A764	In front of respective door jambs	151- 6-1	
Front Park/Turn Lamps	C1024, C1028		Respective front sides of car	151- 2-F8	
Front Side Marker Lamps	C1022, C1026		Front of respective fenders	151- 3-E9	
Front Window Motors	C504, C604		In lower front of respective doors	151- 13-1	
Fuel Gauge Sender	C410	9H307	Below rear of car, top LH side of fuel tank	151- 18-1	
Fuel Injectors (2.3L)	C178, C179, C180, C181	9F593	Top of each cylinder	151- 2-A4	
Fuel Injectors (5.0L)	C178 through C185	9F593	Top of each cylinder	151- 3-A4	
Fuel Pump	C411	9350	Below rear of car, top RH side of fuel tank	151- 17-2	
Fuel Pump Relay	C2027	9345	Below LH front seat, on bracket	151- 14-1	150- 4
Fuse Link A (2.3L)		14526	Front of LH fender apron, at starter relay	151-2-C10	
Fuse Link A (5.0L)		14526	Front of LH fender apron, at starter relay	151- 3-C9	
Fuse Link B (2.3L)		14526	Front of LH fender apron, at starter relay	151-2-C10	
Fuse Link B (5.0L)		14526	Front of LH fender apron, at starter relay	151- 3-C9	
Fuse Link C (2.3L)		14526	Front of LH fender apron, at starter relay	151-2-C10	
Fuse Link C (5.0L)		14526	Front of LH fender apron, at starter relay	151- 3-C9	
Fuse Link D		14526	Front of LH fender apron, at starter relay	151- 3-C9	
Fuse Link E (2.3L)		14526	LH side of engine compartment, behind battery	151- 1-D9	
Fuse Link E (5.0L)		14526	LH side of engine compartment, behind battery	151- 4-D9	
		14526	Front of LH fender apron, at starter relay	151-2-D10	
		14526	Front of LH fender apron, at starter relay	151- 4-C9	
		14526	Front of LH fender apron, at starter relay	151- 1-C9	

100% SATISFACTION GUARANTEED

BUY IT NOW!

Click Here To Order

PayPal American Express Discover MasterCard VISA

LOCATION INDEX 152-8

100% SATISFACTION GUARANTEED

BUY IT NOW!

Click Here To Order

Use Link N

	<u>Connector</u>	<u>Base Part No.</u>	<u>Location</u>	<u>Page Figure/Zone</u>	<u>Connector Page</u>
		14526	Front of LH fender apron, at starter relay	151- 1-C9	
		14526	Front of LH fender apron, at starter relay	151- 1-C9	
(2.3L)		14526	RH rear corner of engine compartment, taped to engine harness	151- 1-A1	
(5.0L)		14526	RH rear corner of engine compartment, taped to engine harness	151- 3-A1	
(2.3L)		14526	LH rear corner of engine compartment	151-2-A10	
(5.0L)		14526	LH rear corner of engine compartment, taped in main harness	151- 4-B9	
Fuse Panel		14A068	Behind LH side of I/P	151- 11-1	
Glove Box Lamp And Switch	C2016		RH side of I/P, in glove box	*	
Hatchback Release Solenoid	C412	14030	Center rear of hatchback, near latch assembly	151- 17-1	
Hazard Flasher		13350	Behind LH side of I/P, on fuse panel	151- 6-3	
Hazard Warning Switch	C299		LH side of I/P, RH side of instrument cluster	151- 7-3	150- 9
Headlamps	C1023, C1027		Respective front sides of car	151- 1-F9	
Heated Exhaust Gas Oxygen (HEGO) Sensor	C186	9F472	RH rear of engine, in exhaust manifold	151- 1-A3	
Heater Control Assembly	C2021		Center of I/P	*	
Hi Mount Stop Lamp (2 door)	C321		Center of rear package tray	*	
Hi Mount Stop Lamp (3 Door)	C430		In center of rear spoiler	*	
Hi Mount Stop Lamp (Convertible)	C431		Center rear of deck lid	*	
Horn Relay	C187	13853	Behind center of I/P, above warning chime module	151- 9-2	150- 9
Horns (2.3L)	C188, C189	13832	In front of LH fender, near windshield washer fluid reservoir	151-2-E10	
Horns (5.0L)	C188, C189	13832	In front of LH fender, near windshield washer fluid reservoir	151- 3-E9	
Idle Air Bypass Valve (2.3L)	C190		Top center rear of engine, above valve cover	151- 2-A3	
Idle Air Bypass Valve (5.0L)	C190		Top RH side of engine, forward of throttle position sensor	151- 3-C1	
Ignition Coil	C191	12029	LH side of engine compartment, on front of shock tower	151- 3-B9	
Ignition Key Warning Switch	C2026	11A127	Top RH side of steering column, part of ignition lock cylinder	151- 9-1	

* No Figure Available

152-9 LOCATION INDEX

<u>Component</u>	<u>Connector</u>	<u>Base Part No.</u>	<u>Location</u>	<u>Page Figure/Zone</u>	<u>Connector Page</u>
Ignition Suppression Resistor		8L603	LH rear corner of engine compartment, taped to engine harness	151- 3-A9	
Ignition Switch	C2001	11572	Top RH side of steering column	151- 9-1	150- 10
In-Line Circuit Breaker (2.3L)		14526	Front of LH fender apron, on starter relay	151- 1-C9	
In-Line Circuit Breaker (5.0L)		14526	Front of LH fender apron, on starter relay	151- 3-C9	
Inertia Switch	C413	9341	Lower center rear of cargo compartment/trunk	151- 18-2	
Instrument Cluster	C250, C251	10B966	Top LH side of I/P	151- 8-2	150- 11
Instrument Panel Dimming Rheostat	C2022		LH side of I/P, left of steering column	*	
Integral Alternator Regulator (IAR) (2.3L)	C153, C154	10300/10346	Top LH front of engine	151- 2-F6	150- 2
Integral Alternator Regulator (IAR) (5.0L)	C153, C154	10300/10346	RH front of engine	151- 4-F4	150- 2
Integrated Control Module	C192		Mounted on front of RH front shock tower	151- 2-C1	150- 12
Interval Governor	C2002	17C476	Behind LH side of I/P, LH side of steering column brace	151- 8-1	150- 10
LCD Illumination Relay	C2004		Behind center of I/P, near horn relay	151- 9-2	150- 13
Left Heated Exhaust Gas Oxygen (HEGO) Sensor	C193	9F472	Lower LH rear of engine, in exhaust manifold	151- 3-A6	
Left Rear Window Control Switch	C306	14529	Front of LH rear quarter panel, on trim panel	151- 15-1	150- 24
License Lamps	C426, C427		Center rear of car	*	
Low Coolant Switch	C194	10D968	LH front of engine compartment, in coolant reservoir	151- 4-F7	
Low Oil Level Sensor	C195	6C624	Lower LH rear of engine, on side of oil pan	151- 5-2	
Low Oil Warning Relay	C196	6C625	Behind LH side of I/P, LH side of steering column brace	151- 8-1	150- 14
Lower Relay	C414		Behind center of rear seat, LH side of convertible top motor	151- 15-1	150- 13
Luggage Compartment Lamp	C428		Center rear of trunk lid	151- 14-3	
Light Switch	C2005	11654	LH side of I/P, LH side of instrument cluster	151- 7-2	150- 14
	C318		Center of windshield header	*	
	C197	12B579	RH side of engine compartment, on air cleaner	151- 1-D1	

100% SATISFACTION GUARANTEED

BUY IT NOW!

Click Here To Order

PayPal American Express Discover MasterCard VISA

LOCATION INDEX 152-10

<u>Component</u>	<u>Connector</u>	<u>Base Part No.</u>	<u>Location</u>	<u>Page Figure/Zone</u>	<u>Connector Page</u>
Mass Air Flow (MAF) Sensor (5.0L) ...	C197	12B579 ...	RH side of engine compartment, near air cleaner	151- 4-C1	
Master Window Control Switch (2 And 3 Door)	C502		Center of LH door, on door panel	151- 13-1	150- 22
Master Window Control Switch (Convertible)	C505		Center of LH door, on door panel	151- 13-1	150- 23
Multi-function Switch	C268, C269, C270	13K359 ...	Inside top of steering column	151- 9-1	150- 14
Neutral Sense Switch	C1033	7A247 ...	Top front of manual transmission	151- 5-4	
Noise Capacitor	C199	18827 ...	RH top of engine, near secondary coil	151- 1-B1	
Octane Adjust Shorting Bar	C1000		RH rear of engine compartment	*	
Oil Pressure Sender	C1001		Lower LH front of engine, above oil filter	151- 4-A6	
Oil Pressure Switch	C1002	9278 ...	LH rear of engine, below valve cover	*	
Park Brake Switch	C2006	15A851 ...	Below center console, on rear of park brake lever assembly	151- 14-1	
Power Lumbar Compressor Motors	C307, C308		Under respective seats	151- 14-1	
Power Lumbar Seat Switches	C322, C323		On side of respective seats	*	
Power Mirror Switch	C350	17682 ...	On center console	151- 14-1	150- 15
Power Mirrors	C508, C607		Front of respective doors	*	
Power Steering Pressure Switch	C1003	3N824 ...	Lower LH side of engine, near power steering pump	151- 2-F7	
Premium Sound Amplifier (Without Graphic Equalizer)	C282, C283 ..	18B849 ...	Below front of center console	151- 10-2	150- 16
Premium Sound Amplifier (With Graphic Equalizer)	C282	18B849 ...	Below front of center console	151- 10-2	150- 26
Premium Sound Amplifier (With Graphic Equalizer)	C283	18B849 ...	Below front of center console	151- 10-2	150- 16
Primary Coil	C1004		Top RH front of engine, RH side of valve cover ..	151- 1-A2	
PRNDL Illumination	C320		Center console	*	
Premium Sound Amplifier (With Premium Sound, Graphic Equalizer)	C280, C281 ..	18805 ...	Center of I/P	151- 10-1	150- 8
Premium Sound Amplifier (With Premium Sound, Graphic Equalizer)	C280	18805 ...	Center of I/P	151- 18-3	150- 18

100% SATISFACTION GUARANTEED

BUY IT NOW!

Click Here To Order

PayPal American Express Discover MasterCard VISA

152-11 LOCATION INDEX

<u>Component</u>	<u>Connector</u>	<u>Base Part No.</u>	<u>Location</u>	<u>Page Figure/Zone</u>	<u>Connector Page</u>
Radio (With Premium Sound, with Graphic Equalizer)	C2031	18805	Center of I/P	151- 18-3	150- 25
Radio (Without Premium Sound)	C257, C258	18805	Center of I/P	151- 10-1	150- 17
Radio Noise Capacitor	C1006	18827	RH top of engine, near secondary coil	151- 1-F4	
Raise Relay	C415		Behind center of rear seat, LH side of convertible top motor	151- 15-1	150- 19
Rear Courtesy Lamp Switch	C416	13713	Center rear of cargo area, RH side of latch striker	151- 16-3	
Rear Crash Sensor	C309	14B004-7	In lower front of LH rear quarter panel	151- 12-4	150- 19
Rear Park/Stop Lamps	C419, C424		Respective rear sides of car	151- 18-2	
Rear Side Marker Lamps	C420, C423		Respective rear sides of car	*	
Rear Speakers	C324, C325		Respective sides of rear package tray	*	
Rear Turn Lamps	C418, C422		Respective rear sides of car	151- 18-2	
Rear Window Defrost Control Relay	C2007	18C641	Behind LH side of I/P, on RH side of fuse panel	151- 6-4	150- 19
Rear Window Defrost Switch	C2020		LH side of I/P, right of instrument cluster	*	
Rear Window Motors	C311, C312		In front of respective quarter panels	151- 15-1	
Right Front Window Control Switch	C602	14529	Center of RH door, on door panel	151- 13-1	150- 23
Right Heated Exhaust Gas Oxygen (HEGO) Sensor	C1005	9F472	Lower RH rear of engine, in exhaust manifold	151- 4-A3	
Right Rear Window Control Switch	C314	14529	Front of RH rear quarter panel, on trim panel	151- 15-1	150- 24
Seat Belt Switch	C315	10B924	Inside LH front seat belt buckle assembly	151- 14-1	
Secondary Coil	C1007		Top RH front of engine, right of valve cover	151- 1-D1	
Shift Lock Actuator	C2008		Behind LH side of I/P, right of steering column	*	
Speed Control Amplifier	C214, C215	9D843	Behind LH side of I/P, near top of cowl panel	151- 6-2	150- 20
Speed Control Servo (2.3L)	C1008	9C735	In rear of LH fender	151-2-A10	150- 21
Speed Control Servo (5.0L)	C1008	9C735	In rear of LH fender	151- 3-A9	150- 21
SPOUT Check Connector (2.3L)	C1009	14A464	Top LH front of engine, near distributorless ignition system (DIS) module	151- 1-B9	
SPOUT Check Connector (5.0L)	C1009	14489	LH front of engine, near distributor	151- 3-F5	
Wiper Motor (2.3L)		11001	Lower RH rear of engine	*	
Wiper Motor (5.0L)		11001	Lower RH rear of engine	*	
Wiper Motor (5.0L)		12B598	Front of LH fender apron	151-2-C10	
Wiper Motor (5.0L)		12B598	Front of LH fender apron	151- 3-C9	

100% SATISFACTION GUARANTEED

BUY IT NOW!

Click Here To Order

PayPal American Express Discover MasterCard VISA

LOCATION INDEX 152-12

<u>Component</u>	<u>Connector</u>	<u>Base Part No.</u>	<u>Location</u>	<u>Page Figure/Zone</u>	<u>Connector Page</u>
Steering Column Air Bag	C2009		In center of steering wheel	*	
Steering Wheel Control Switch	C2018		Upper LH side of steering column	151- 9-1	
Stop Lamp Switch	C2011	13480	Behind LH side of I/P, on brake pedal support	151- 6-6	
Tach Service Connector	C1011		LH front of engine, near distributorless ignition system (DIS) module	151-2-B10	
TFI Ignition Module	C1012		Center front of engine, on LH side of distributor	151- 3-F3	150- 21
Thermactor Air Bypass (TAB) Solenoid	C1013		RH rear of engine compartment, on rear of shock tower	151- 4-B1	
Thermactor Air Diverter (TAD) Solenoid	C1014		RH rear of engine compartment, on rear of shock tower	151- 3-B1	
Throttle Position Sensor (2.3L)	C1031	9B989	Top rear of engine	151- 1-A4	
Throttle Position Sensor (5.0L)	C1015	9B989	Top RH side of engine, behind idle air bypass valve	151- 3-A2	
Trunk Lid Release Solenoid	C417	14030	Center rear of trunk lid, near latch assembly	151- 14-3	
Trunk Lid/Hatchback Release Switch	C2019		RH side of I/P, in glove box	*	
Turn Signal Flasher	C2012	13350	Behind center of I/P, below radio	151- 11-1	
Vanity Mirror Lamps	C316, C317		On respective vanity mirrors	*	
Vehicle Speed Sensor (VSS) (Automatic)	C1016	9E731	LH rear of transmission	151- 5-3	
Vehicle Speed Sensor (VSS) (Manual)	C1016	9E731	LH rear of transmission	151- 5-4	
VIP Test Connector C198 (2.3L)		14489	LH rear corner of engine compartment	151- 2-A9	150- 21
VIP Test Connector C198 (5.0L)		14489	LH rear corner of engine compartment	151- 4-A8	150- 21
VIP Test Connector C199 (2.3L)		14489	LH rear corner of engine compartment	151- 1-A9	150- 21
VIP Test Connector C199 (5.0L)		14489	LH rear corner of engine compartment	151- 3-A8	150- 21
Warning Chime Module	C2013	10D840	Behind center of I/P, RH side of steering column	151- 9-2	150- 22
Safety Relay	C2014	14677	Behind LH cowl panel	151- 5-6	150- 25
	C1018	17664	In front of LH fender, in windshield washer fluid reservoir	151-2-D10	

100% GUARANTEED

BUY IT NOW!

Click Here To Order

PayPal American Express Discover MasterCard VISA

152-13 LOCATION INDEX

<u>Component</u>	<u>Connector</u>	<u>Base Part No.</u>	<u>Location</u>	<u>Page Figure/Zone</u>	<u>Connector Page</u>
Windshield Washer Pump Motor (5.0L)	C1018	17664	In front of LH fender, in windshield washer fluid reservoir	151- 3-D9	
Windshield Washer Pump Test Connector (2.3L)	C1019		Lower LH side of engine compartment, taped to main harness	*	
Windshield Washer Pump Test Connector (5.0L)	C1019		Lower LH side of engine compartment, taped to main harness	151- 4-B9	
Windshield Wiper Motor (2.3L)	C151, C152	17504/ 17A553	LH side of safety wall, RH side of hood hinge	151- 1-A7	150- 24
Windshield Wiper Motor (5.0L)	C151, C152	17504/ 17A553	LH side of safety wall, RH side of hood hinge	151- 3-A7	150- 24
WOT Cutout Relay	C1020		RH side of engine compartment, on lower front of wheel well	151- 4-D1	150-25

* No Figure Available

<u>Connector</u>	<u>Location</u>	<u>Page Figure/Zone</u>	<u>Connector Page</u>	<u>Color</u>	<u>Terminal</u>
C100	Lower LH front of engine compartment	151- 4-D9		BK	2
C101 (2.3L)	LH side of engine, behind intake manifold	151- 2-A7		BK	8
C101 (5.0L)	RH side of engine compartment	151- 3-C1		BK	8
C102	LH rear corner of engine compartment	151- 5-1			2
C104	LH side of engine, behind intake manifold	151- 2-A6		BK	8
C105	LH side of engine, behind intake manifold	151- 1-A7		GY	8
C106 (Automatic)	LH rear of transmission	151- 5-3		GY	4
C106 (Manual)	LH side of transmission	151- 5-4		GY	4
C106 (2.3L)	LH side of engine compartment, on lower front of wheel well	151-2-B10		BL	2
C106 (5.0L)	LH side of engine compartment, on lower front of wheel well	151- 3-B9		BL	2
C106 (5.0L)	LH side of engine compartment, on lower front of wheel well	151-2-B10		BK	8
C106 (5.0L)	LH side of engine compartment, on lower front of wheel well	151- 3-B9		BK	8
C106 (5.0L)	LH rear of engine compartment	151- 1-A8		BK	8

100% SATISFACTION GUARANTEED

BUY IT NOW!

Click Here To Order

PayPal American Express Discover MasterCard VISA

LOCATION INDEX 152-14

<u>Connector</u>	<u>Location</u>	<u>Page</u> <u>Figure/Zone</u>	<u>Connector</u> <u>Page</u>	<u>Color</u>	<u>Terminal</u>
C110 (5.0L)	LH rear of engine compartment	151- 3-B9		BK	8
C111	LH side of engine, near bottom of intake manifold, on crankshaft position sensor	151- 2-F5	.. 150- 4	GY	1
C112	LH side of engine, near bottom of intake manifold, on crankshaft position sensor	151- 2-F5	.. 150- 4	GY	4
C113 (2.3L)	LH front of engine compartment, behind battery	151-2-D10		BK	1
C113 (5.0L)	LH front of engine compartment, behind battery	151- 4-D9		BK	1
C117	LH front of manual transmission	151- 5-4		BK	2
C118	Top RH side of engine, on rear of intake manifold	151- 4-A4		BK	10
C119	Top RH side of engine, on rear of intake manifold	151- 3-A4		GY	10
C151 (2.3L)	LH side of safety wall, on windshield wiper motor	151- 2-A8	.. 150-24	GY	3
C151 (5.0L)	LH side of safety wall, on windshield wiper motor	151- 4-A8	.. 150-24	GY	3
C152 (2.3L)	LH side of safety wall, on windshield wiper motor	151- 2-A8	.. 150-24	BK	3
C152 (5.0L)	LH side of safety wall, on windshield wiper motor	151- 4-A7	.. 150-24	BK	3
C153 (2.3L)	Top LH front of engine, on integral alternator regulator (IAR)	151- 1-F5	.. 150- 2	BK	3
C153 (5.0L)	RH front of engine, on integral alternator regulator (IAR)	*	.. 150- 2	BK	3
C154 (2.3L)	Top LH front of engine, on integral alternator regulator (IAR)	151- 1-F6	.. 150- 2	BK	3
C154 (5.0L)	RH front of engine, on integral alternator regulator (IAR)	*	.. 150- 2	BK	3
C155	Top LH front of engine, on distributorless ignition system (DIS) module	151- 1-F7	.. 150- 3		6
C156	Lower LH front of engine, on distributorless ignition system (DIS) module	151- 1-F7	.. 150- 3		6
C157	Under center of car, on A4LD transmission	151- 5-3		BK	3
C158	Underside of hood, on engine compartment lamp	151- 5-1			2
C159 (2.3L)	Lower RH front of engine, on A/C compressor assembly	151- 2-F3		BK	2
C159 (5.0L)	Top LH front of engine, on A/C clutch field coil	151- 4-F6		BK	2
C160 (2.3L)	RH side of engine, on air charge temperature (ACT) sensor	151- 2-D1		BK	2
C160 (5.0L)	Top center of engine, on air charge temperature (ACT) sensor	151- 3-F6		BK	2
C121	LH side of manual transmission, on backup lamp switch	151- 5-4		BK	2
	LH side of automatic transmission, on backup/neutral safety switch	151- 5-3		BK	4
	Center of safety wall, on barometric absolute pressure (BAP) sensor	151- 1-A5		BK	3

100% SATISFACTION GUARANTEED

BUY IT NOW!

Click Here To Order

PayPal American Express Discover MasterCard VISA

152-15 LOCATION INDEX

<u>Connector</u>	<u>Location</u>	<u>Page Figure/Zone</u>	<u>Connector Page</u>	<u>Color</u>	<u>Terminal</u>
C163 (5.0L)	Center of safety wall, on barometric absolute pressure (BAP) sensor	151- 4-A5		BK	3
C164 (2.3L)	LH rear of engine compartment, on brake fluid level switch	151- 1-A9			3
C164 (5.0L)	LH rear of engine compartment, on brake fluid level switch	151- 3-B9			3
C165	Lower RH side of engine, on canister purge solenoid	151- 4-D1		BK	2
C166 (2.3L)	Top center of upper radiator support, on center line crash sensor	151- 1-F5		BK	2
C166 (5.0L)	Top center of upper radiator support, on center line crash sensor	151- 4-F5		BK	2
C167 (2.3L)	RH rear corner of engine compartment, on clutch cycling pressure switch	151- 2-A1		GY	3
C167 (5.0L)	RH rear corner of engine compartment, on clutch cycling pressure switch	151- 4-A2		GY	3
C168 (2.3L)	Lower LH side of engine, on coolant temperature sender	*			1
C168 (5.0L)	Top center front of engine, on coolant temperature sender	151- 3-F4			1
C170 (2.3L)	In front of LH fender, on daytime running lamps (DRL) module or DRL shorting connector	151- 1-E9	.. 150-4		8
C170 (5.0L)	In front of LH fender, on daytime running lamps (DRL) module or DRL shorting connector	151- 4-E9	.. 150-4		8
C171 (2.3L)	RH rear of engine compartment, on EGR vacuum regulator solenoid	151- 2-B1		BK	2
C171 (5.0L)	RH rear of engine compartment, on EGR vacuum regulator solenoid	151- 4-B1		BK	2
C172 (2.3L)	Top LH rear of engine, on EGR valve position sensor	151- 2-A5			4
C172 (5.0L)	Top RH side of engine, on EGR valve position sensor	151- 3-A3			4
C173	Center front of engine compartment, on electric cooling fan	151- 2-F4		BK	2
C174 (2.3L)	RH rear of engine, on engine coolant temperature (ECT) sensor	151- 2-A2		BR	2
(5.0L)	Top RH front of engine, on engine coolant temperature (ECT) sensor	151- 3-D1		BR	2
	.. RH side of engine compartment, to right forward crash sensor	151- 1-F3			2
	.. RH side of engine compartment, to right forward crash sensor	151- 4-F3			2
	.. LH side of engine compartment, to left forward crash sensor	151- 1-F8			2

100% SATISFACTION GUARANTEED

BUY IT NOW!

Click Here To Order

PayPal American Express Discover MasterCard VISA

LOCATION INDEX 152-16

<u>Connector</u>	<u>Location</u>	<u>Page</u> <u>Figure/Zone</u>	<u>Connector</u> <u>Page</u>	<u>Color</u>	<u>Terminal</u>
C177 (5.0L)	LH side of engine compartment, to left forward crash sensor	151- 4-F8			2
C178	Top of engine, on fuel injector No. 1	★			2
C179	Top of engine, on fuel injector No. 2	★			2
C180	Top of engine, on fuel injector No. 3	★			2
C181	Top of engine, on fuel injector No. 4	★			2
C182	Top of engine, on fuel injector No. 5	★			2
C183	Top of engine, on fuel injector No. 6	★			2
C184	Top of engine, on fuel injector No. 7	★			2
C185	Top of engine, on fuel injector No. 8	★			2
C186	RH rear of engine, on heated exhaust gas oxygen (HEGO) sensor	151- 1-A3		GY	4
C187	Behind center of I/P, on horn relay	151- 9-2	.. 150-9		5
C188 (2.3L)	In front of LH fender, on high pitch horn	151-2-E10			1
C188 (5.0L)	In front of LH fender, on high pitch horn	151- 3-E9			1
C189 (2.3L)	In front of LH fender, on low pitch horn	151-2-E10			1
C189 (5.0L)	In front of LH fender, on low pitch horn	151- 3-E9			1
C190 (2.3L)	Top center rear of engine, on idle air bypass valve	151- 2-A3		BK	2
C190 (5.0L)	Top RH side of engine, on idle air bypass valve	151- 3-C1		BK	2
C191	LH side of engine compartment, on ignition coil	151- 3-B9		GY	3
C192	On front of RH shock tower, on integrated control module	151- 2-C1	.. 150-12	GY	24
C193	LH rear of engine, on left heated exhaust gas oxygen (HEGO) sensor	151- 3-A6		BK	4
C194	LH front of engine compartment, on low coolant switch	151- 4-F7		BK	3
C195	Lower LH rear of engine, on low oil level sensor	151- 5-2		N	1
C196	Behind LH side of I/P, on low oil warning relay	151- 3-A6	.. 150-14		5
C197 (2.3L)	RH side of engine compartment, on mass air flow (MAF) sensor	151- 1-D1			4
C197 (5.0L)	RH side of engine compartment, on mass air flow (MAF) sensor	151- 4-C1			4
C198 VIP Test Connector (2.3L)	LH rear corner of engine compartment	151- 2-A9	.. 150-21	GY	6
C198 VIP Test Connector (5.0L)	LH rear corner of engine compartment	151- 4-A8	.. 150-21	GY	6
C199	LH rear corner of engine compartment	151- 1-A9	.. 150-21	GY	1
C200	LH rear corner of engine compartment	151- 3-A8	.. 150-21	GY	1
C201	Inside top of steering column	151- 9-1		GY	1
C202	Behind LH cowl panel	151- 5-5		BK	12



BUY IT NOW!

[Click Here To Order](#)

★ No figure available



152-17 LOCATION INDEX

<u>Connector</u>	<u>Location</u>	<u>Page</u> <u>Figure/Zone</u>	<u>Connector</u> <u>Page</u>	<u>Color</u>	<u>Terminal</u>
C203 (Convertible)	Behind LH cowl panel	151- 5-6		BK	12
C204 (2 And 3 Door)	Behind LH cowl panel, taped to main harness	151- 5-5		GY	2
C204 (Convertible)	Behind LH cowl panel, taped to main harness	151- 5-6		GY	2
C205	Behind RH cowl panel, near electronic engine control (EEC) module	151- 10-4		GY	2
C206	Behind LH side of I/P, on rear of fuse panel	151- 6-4		W	1
C207 (2 And 3 Door)	Behind LH cowl panel	151- 5-5		GY	12
C207 (Convertible)	Behind LH cowl panel	151- 5-6		GY	12
C212 (2 And 3 Door)	Behind LH cowl panel	151- 5-5		BK	8
C212 (Convertible)	Behind LH cowl panel	151- 5-6		BK	8
C213	Behind RH cowl panel, below electronic engine control (EEC) module	151- 10-4		GR	8
C214	Behind LH side of I/P, on speed control amplifier	151- 6-2 .. 150-20			6
C215	Behind LH side of I/P, on speed control amplifier	151- 6-2 .. 150-20		GY	6
C216	Behind RH cowl panel, below electronic engine control (EEC) module	151- 10-4		GY	8
C217	Behind LH cowl panel	*		GY	8
C221	Behind LH cowl panel	151- 5-5		GY	8
C222	Behind RH cowl panel, above grommet	151- 10-4		GY	8
C224	Behind LH cowl panel	151- 5-6		BL	6
C225	Behind LH cowl panel	151- 5-6		BK	4
C227 (2 And 3 Door)	Behind LH cowl panel	151- 5-5		GY	2
C227 (Convertible)	Behind LH cowl panel	151- 5-6		GY	2
C228	Behind RH cowl panel, above grommet	151- 10-4		GY	2
C229	Behind LH cowl panel	151- 5-6		GY	8
C230 (2 And 3 Door)	Behind LH cowl panel	151- 5-5		BK	4
C230 (Convertible)	Behind LH cowl panel	151- 5-6		BK	4
C231	Behind RH cowl panel, below grommet	151- 10-4		BK	4
C250	Behind top LH side of I/P, on instrument cluster	151- 8-2 .. 150-11		GY	14
	Behind top LH side of I/P, on instrument cluster	151- 8-2 .. 150-11		BR	14
	Behind center of I/P, near radio	151- 10-3		BK	8
	Behind center of I/P, on rear of radio	151- 10-1 .. 150-17		BK	8
	Behind center of I/P, near radio	151- 10-3		BK	8

100% SATISFACTION GUARANTEED

BUY IT NOW!

Click Here To Order

PayPal American Express Discover MasterCard VISA

LOCATION INDEX 152-18

<u>Connector</u>	<u>Location</u>	<u>Page</u>		<u>Color</u>	<u>Terminal</u>
		<u>Figure/Zone</u>	<u>Page</u>		
C258 (Without Premium Sound)	Behind center of I/P, on rear of radio	151- 10-1	.. 150-17	BK	8
C268	Inside top of steering column, on multi-function switch	151- 9-1	.. 150-14	GY	4
C269	Inside top of steering column, on multi-function switch	151- 9-1	.. 150-15	GY	10
C270	Inside top of steering column, on multi-function switch	151- 9-1	.. 150-13	GY	10
C276	Behind center of I/P, on air bag diagnostic module	151- 11-1	.. 150- 1	GY	12
C277	Behind center of I/P, on air bag diagnostic module	151- 11-1	.. 150- 1	BK	12
C280	Behind center of I/P, on rear of radio	151- 10-1	.. 150-18	BK	8
C281 (with Graphic Equalizer)	Behind center of I/P, on rear of radio	151- 18-3	.. 150-25	BK	8
C281 (without Graphic Equalizer)	Behind center of I/P, on rear of radio	151- 10-1	.. 150-18	BK	8
C282	Below front of center console, on premium sound amplifier	151- 10-2	.. 150-16	GY	8
C283	Below front of center console, on premium sound amplifier	151- 10-2	.. 150-16	GY	8
C284	Behind RH side of I/P, on air bag backup power supply	151- 11-1	.. 150- 2	BK	6
C285	Center of I/P, on A/C-heater control assembly	★		W	4
C286	Behind RH side of I/P, on blower motor	151- 12-2		BK	2
C287	Behind RH side of I/P, on blower motor assembly	151- 12-2		W	4
C288	Behind LH side of I/P, on clutch interrupt switch	151- 7-1		BK	2
C289	Behind LH side of I/P, on clutch pedal switch	151- 6-5			2
C290	Behind LH side of I/P, on clutch sense switch	151- 7-1		N	2
C291	Behind LH side of I/P, on clutch switch or clutch switch jumper	151- 6-5		GY	2
C293	Behind RH cowl panel, on EEC power relay	151- 10-4			5
C294	Behind RH cowl, on electronic engine control (EEC) module (2.3L)	151- 10-4	.. 150- 5	GY	60
C295	Behind RH cowl, on electronic engine control (EEC) module (5.0L)	151- 10-4	.. 150- 7	GY	60
C296	In front of RH door jamb, on right front courtesy lamp switch	151- 6-1		BK	3
C297	In front of LH door jamb, on left front courtesy lamp switch	151- 6-1		BK	3
C298	LH side of I/P, on fog lamp switch	151- 7-2		N	2
C299	LH side of I/P, on hazard warning switch	151- 7-3	.. 150- 9	GY	8
	Below LH front seat	151- 14-1		GY	2
	Below RH front seat	151- 14-1		GY	2
	Below center console	151- 14-1		GY	3
	Below center console	151- 14-1		GY	2
	Front of LH rear trim panel, on left rear window control switch	151- 5-1	.. 150-24	BK	5



BUY IT NOW!

Click Here To Order

★ No Figure Available



152-19 LOCATION INDEX

<u>Connector</u>	<u>Location</u>	<u>Page</u> <u>Figure/Zone</u>	<u>Connector</u> <u>Page</u>	<u>Color</u>	<u>Terminal</u>
C307	Under left seat, on power lumbar compressor motor	151- 14-1		BK	2
C308	Under right seat, on power lumbar compressor motor	151- 14-1		BK	2
C309	In lower front of LH rear quarter panel, on rear crash sensor	151- 12-4	.. 150-19	GY	8
C311	In front of LH quarter panel, on left rear window motor	151- 15-1		GY	2
C312	In front of RH quarter panel, on right rear window motor	151- 15-1		GY	2
C314	Front of RH rear trim panel, on right rear window control switch	151- 15-1	.. 150-24	BK	5
C315	Part of LH front seat belt buckle assembly, on seat belt switch	151- 14-1		GY	2
C316	On RH vanity mirror lamp	*		W	1
C317	On LH vanity mirror lamp	*		W	1
C318	Center of windshield header, on map lamp	*		GY	1
C319	Center console, on ashtray illumination	*			2
C320	Center console, on PRNDL illumination	*		GY	2
C321	Center of rear package tray, on hi mount stop lamp	*			2
C322	On side of right seat, on power lumbar seat switch	*		GY	2
C323	On side of left seat, on power lumbar seat switch	*		GY	2
C324	RH side of rear package tray, on rear speaker	*		GY	2
C325	LH side of rear package tray, on rear speaker	*		GY	2
C326	Forward center of roof, on dome lamp	*		GY	1
C327	Forward center of roof, on dome lamp	*		GY	2
C350	Below center console, on power mirror switch	151- 14-1	.. 150-15	GY	8
C400	Below rear of car, above rear of fuel tank	151- 16-4		BR	4
C401	LH rear corner of hatchback	151- 17-1		GY	3
C403 (2 Door And Convertible)	LH side of trunk, above rear of wheel well	151- 16-1		GY	3
C403 (3 Door)	LH side of cargo area, above rear of wheel well	151- 16-2		GY	3
C405 (2 Door And Convertible)	LH side of trunk, above rear of wheel well	151- 16-1		GY	1
C405 (3 Door)	LH side of cargo area, above rear of wheel well	151- 16-2		GY	1
C406 (2 Door And Convertible)	LH side of trunk, above rear of wheel well	151- 16-1		BR	1
C406 (3 Door)	LH side of cargo area, above rear of wheel well	151- 16-2		BR	1
C407	LH rear corner of hatchback	151- 17-1		BR	1
	LH rear corner of hatchback	151- 17-1		BK	1
	Behind center of rear seat, on convertible top motor	151- 15-1			2
	Below rear of car, on fuel gauge sender	151- 18-1		GY	2
	Below rear of car, on fuel pump	151- 17-2		R	2

100% SATISFACTION GUARANTEED

BUY IT NOW!

Click Here To Order

PayPal American Express Discover MasterCard VISA

LOCATION INDEX 152-20

<u>Connector</u>	<u>Location</u>	<u>Page</u> <u>Figure/Zone</u>	<u>Connector</u> <u>Page</u>	<u>Color</u>	<u>Terminal</u>
C412	Center rear of hatchback, on hatchback release solenoid	151- 17-1		N	2
C413	Lower center rear of cargo compartment/trunk, on inertia switch	151- 18-2			3
C414	Behind center of rear seat, on lower relay	151- 15-1	.. 150-13		5
C415	Behind center of rear seat, on raise relay	151- 15-1	.. 150-19		5
C416	Center rear of cargo area, on rear courtesy lamp switch	151- 16-3		BK	3
C417	Center rear of trunk lid, on trunk lid release solenoid	151- 14-3		GY	1
C418	LH rear of car, on left rear turn lamp	151- 18-2		BK	2
C419	LH rear of car, on left rear park/stop lamp	151- 18-2			3
C420	LH rear of car, on left rear side marker lamp	*			2
C421	LH rear of car, on left backup lamp	151- 18-2		BK	2
C422	RH rear of car, on right rear turn lamp	151- 18-2		BK	2
C423	RH rear of car, on right rear side marker lamp	*			2
C424	RH rear of car, on right rear park/stop lamp	151- 18-2			3
C425	RH rear of car, on right backup lamp	151- 18-2		BK	2
C426	Center rear of car, on right license lamp	*			2
C427	Center rear of car, on left license lamp	*			2
C428	Center rear of trunk lid, on luggage compartment lamp	151- 14-3		BK	1
C429	Center rear of cargo area, on cargo lamp	*			2
C430	In center of rear spoiler, on hi mount stop lamp	*			2
C431	Center rear of deck lid, on hi mount stop lamp	*		GY	2
C500	In center of LH door	*		GY	8
C501	In center of LH door	*		GY	4
C502	Center of LH door, on door lock switch/master window control switch	151- 13-1	.. 150-22	BK	15
C503	In rear of LH door, on door lock motor	151- 13-1		GY	2
C504	In lower front of LH door, on left front window motor	151- 13-1		GY	2
C505	Center of LH door, on window control switch/door lock switch	*	.. 150-23	BK	16
C	Center of LH door, on door lock switch	*		BR	6
C	In front of LH door, on door speaker	*		GY	2
C	Front of LH door, on left power mirror	*		GY	3
C	In center of RH door	*		BR	6
C	In center of RH door	*		BR	6

100% SATISFACTION GUARANTEED

BUY IT NOW!

Click Here To Order

PayPal American Express Discover MasterCard VISA

* No figure available

152-21 LOCATION INDEX

<u>Connector</u>	<u>Location</u>	<u>Page</u> <u>Figure/Zone</u>	<u>Connector</u> <u>Page</u>	<u>Color</u>	<u>Terminal</u>
C602	Center of RH door, on door lock switch/window control switch	151- 13-1	.. 150-23	BK	10
C603	In rear of RH door, on door lock motor	151- 13-1		GY	2
C604	In lower front of RH door, on right front window motor	151- 13-1		GY	2
C606	Center of RH door, on door lock switch	*		BR	6
C607	In front of RH door, on door speaker	*		GY	2
C608	Front of RH door, on right power mirror	*		GY	3
C1000	RH rear of engine compartment, on octane adjust shorting bar	*			2
C1001	Lower LH front of engine, on oil pressure sender	151- 4-F6			1
C1002	LH rear of engine, on oil pressure switch	*			1
C1003	Lower LH side of engine compartment, on power steering pressure switch	151- 2-F7			2
C1004	Top RH front of engine, on primary coil	151- 1-A2		BK	3
C1005	RH rear of engine, on right heated exhaust gas oxygen (HEGO) sensor	151- 4-A3		BK	4
C1006	RH top of engine, on radio noise capacitor	151- 1-F4		GY	1
C1007	Top RH front of engine, on secondary coil	151- 1-D1		BK	3
C1008 (2.3L)	In rear of LH fender, on speed control servo	151-2-A10	.. 150-21		6
C1008 (5.0L)	In rear of LH fender, on speed control servo	151- 3-A9	.. 150-21		6
C1009 SPOUT Check Connector (2.3L)	Top LH front of engine, near distributorless ignition system (DIS) module	151- 1-B9			2
C1009 SPOUT Check Connector (5.0L)	LH front of engine, near distributor	151- 3-F5			2
C1011 Tach Service Connector	LH front of engine	151-2-B10		BK	2
C1012	Center front of engine, on TFI ignition module	151- 3-F3	.. 150-21	GY	6
C1013	RH rear of engine compartment, on thermactor air bypass (TAB) solenoid	151- 4-B1			2
C1014	RH rear of engine compartment, on thermactor air diverter (TAD) solenoid	151- 3-B1			2
	Top RH side of engine, on throttle position sensor	151- 3-A2		BK	3
	LH rear of transmission, on vehicle speed sensor (VSS)	151- 5-3		BK	2
	LH rear of transmission, on vehicle speed sensor (VSS)	151- 5-4		BK	2
	In front of LH fender, on windshield washer pump motor	151-2-D10		BK	2

100% SATISFACTION GUARANTEED

BUY IT NOW!

Click Here To Order

PayPal American Express Discover MasterCard VISA

LOCATION INDEX 152-22

<u>Connector</u>	<u>Location</u>	<u>Page</u> <u>Figure/Zone</u>	<u>Connector</u> <u>Page</u>	<u>Color</u>	<u>Terminal</u>
C1018 (5.0L)	In front of LH fender, on windshield washer pump motor	151- 3-D9		BK	2
C1019 Windshield Washer Pump					
Test Connector	Lower LH side of engine compartment, taped to main harness	151-3-B10		GY	1
C1020	RH side of engine compartment, on WOT cutout relay	151- 4-D1	.. 150-25		5
C1021	Center front of car, on left fog lamp	151- 3-F8			2
C1022	LH front of car, on left front side marker lamp	151- 3-E9			2
C1023	LH front of car, on left headlamp	151- 4-F9	.. 150- 9	BK	5
C1024	LH front of car, left front park/turn lamp socket	151- 2-F8			3
C1025	Center front of car, on right fog lamp	151- 3-F2			2
C1026	RH front of car, on right front side marker lamp	151- 2-E1			2
C1027	RH front of car, on right headlamp	151- 4-E1	.. 150- 9	BK	5
C1028	RH front of car, right front park/turn lamp socket	151- 3-E1			3
C1029	LH front of engine compartment, near left fog lamp	*		BK	2
C1030	RH front of engine compartment, near right fog lamp	*		BK	2
C1031	Top rear of engine, on throttle position sensor	151- 1-A4		BK	3
C1032	RH side of engine compartment, on canister purge solenoid	151- 2-D1			2
C1033	Top front of manual transmission, on neutral sense switch	151- 5-4		BK	2
C1034	RH top of engine, on noise capacitor	151- 1-B1		GY	1
C2001	Top RH side of steering column, on ignition switch	151- 9-1	.. 150-10	BK	11
C2002	Behind LH side of I/P, on interval governor	151- 8-1	.. 150-10	BK	10
C2004	Behind center of I/P, on LCD illumination relay	151- 9-2			5
C2005	LH side of I/P, on main light switch	151- 7-2	.. 150-14	GY	6
C2006	Below center console, on park brake switch	151- 14-1			1
C2007	Behind LH side of I/P, on rear window defrost control relay	151- 6-4	.. 150-19		5
C2008	Behind LH side of I/P, on shift lock actuator	*			3
C2009	In steering wheel, on steering column air bag	*			2
C2010	Top of steering column, on clockspring/slip ring assembly	*			3
C2011	Behind LH side of I/P, on stop lamp switch	151- 6-6			2
C2012	Behind center of I/P, on turn signal flasher	151- 11-1			2
C2013	Behind center of I/P, on warning chime module	151- 9-2	.. 150-22	GY	7
C2014	Behind LH cowl panel, on window safety relay	151- 5-6	.. 150-25		4
C2015	Center of I/P, on blower motor switch	*		GY	4
C2016	RH side of I/P, on glove box lamp and switch	*			2

100% SATISFACTION GUARANTEED

BUY IT NOW!

Click Here To Order

PayPal American Express Cards Discover MasterCard VISA

152-23 LOCATION INDEX

<u>Connector</u>	<u>Location</u>	<u>Page Figure/Zone</u>	<u>Connector Page</u>	<u>Color</u>	<u>Terminal</u>
C2017	Center of I/P, on A/C-heater control illumination	*			2
C2018	Upper LH side of steering column, on steering wheel control switch	151-	9-1	GY	3
C2019	RH side of I/P, on trunk lid/hatchback release switch	*		GY	2
C2020	LH side of I/P, on rear window defrost switch	151-	7-3	GY	4
C2021	Center of I/P, on heater control assembly	*		W	4
C2022	LH side of I/P, on instrument panel dimming rheostat	*		BK	2
C2023	LH side of I/P, on convertible top switch	151-	7-3	GY	4
C2024	RH side of dash, on dash speaker	*		GY	2
C2025	LH side of dash, on dash speaker	*		GY	2
C2026	Upper RH side of steering column, on ignition key warning switch	151-	9-1	GY	1
C2027	Below LH front seat, on fuel pump relay	151-	14-1 .. 150-		4
C2028	Behind LH side of I/P, on convertible top circuit breaker	151-	6-4	GY	1
C2029	Behind LH side of I/P, on convertible top circuit breaker	151-	6-4	GY	1
C2030	Behind center of I/P, on graphic equalizer	151-	18-3 .. 150-	GY	25
C2031	Behind center of I/P, on radio	151-	18-3 .. 150-		26

* No Figure Available

<u>Ground</u>	<u>Location</u>	<u>Page Figure/Zone</u>
G100 (2.3L)	LH side of engine compartment, on front of wheel well	151- 1-D9
G100 (5.0L)	LH side of engine compartment, on front of wheel well	151- 4-D9
G102 (2.3L)	Top front of LH fender apron	151- 1-E9
G102 (5.0L)	Top front of LH fender apron	151- 4-E9
G103 (2.3L)	Top front of RH fender apron	151- 2-E1
G103 (5.0L)	Top front of RH fender apron	151- 4-E1
G104 (2.3L)	Front of LH fender apron, near windshield washer fluid reservoir	151-2-D10
G104 (5.0L)	Front of LH fender apron, near windshield washer fluid reservoir	151- 3-D9
G105	Lower LH front of engine, near integral alternator regulator (IAR)	151- 1-F6
G106	Lower LH side of engine, near A/C compressor assembly	151- 3-F7
G107	LH side of engine compartment, on front of wheel well	151- 1-D9

100% SATISFACTION GUARANTEED

BUY IT NOW!

Click Here To Order

PayPal American Express Discover MasterCard VISA

<u>Ground</u>	<u>Location</u>	<u>Page Figure/Zone</u>
G109	RH rear of engine, below valve cover	151- 4-A6
G200	Behind center of I/P, on I/P support brace	151- 9-3
G201	Behind RH cowl panel, below electronic engine control (EEC) module	151- 10-4
G202	Behind center of I/P, on I/P support brace	151- 9-3
G203	Behind center of I/P, near warning chime module	151- 11-1
G300	Below LH front seat	151- 14-1
G301	Below center console, on park brake assembly	151- 14-1
G302 (2 Door And Convertible)	RH side of trunk, above wheel well	151- 14-2
G302 (3 Door)	In RH side of hatchback, below window	151- 17-1
G303	Center of windshield header	151- 12-3
G304	Behind center of rear seat, LH side of convertible top motor	151- 15-1
G400	Center rear of cargo compartment/trunk, LH side of latch striker	151- 18-2
G401 (2 Door And Convertible)	LH side of trunk, above rear of wheel well	151- 16-1
G401 (3 Door)	LH rear corner of hatchback	151- 17-1
G402	Lower LH side of cargo area, behind wheel well	151- 16-2
G500	In center of LH door	151- 13-1

<u>Splice</u>	<u>Location</u>
S100	Main harness, near T/O to G100
S102	Engine harness, near T/O to VIP test connector C199
S103	Dash panel to headlamp junction harness, near T/O to left headlamp
S104	Dash panel to headlamp junction harness, near T/O to right headlamp
S105	Engine harness, at T/O to C113
S106	Engine harness, in T/O to G106
S107	Engine control sensor extension harness, near T/O to C101
S108	Dash panel to headlamp junction harness, near T/O to low coolant switch
	Main harness, near T/O to windshield washer pump test connector
	Fuel charge harness, near T/O to fuel injector NO. 2
	Main harness, near T/O to windshield washer pump test connector
	Engine harness, near T/O to C101
	Engine harness, near T/O to C101
	Engine control sensor extension harness, near C110



BUY IT NOW!

Click Here To Order









152-25 LOCATION INDEX

<u>Splice</u>	<u>Location</u>
S116	Engine harness, near T/O to C101
S117	Engine control sensor extension harness, near T/O to crankshaft position sensor
S118	Dash panel to headlamp junction harness, near T/O to G102
S119 (2.3L)	Engine harness, near T/O to clutch cycling pressure switch
S119 (5.0L)	Engine harness, near T/O to EEC power relay
S120	Engine control sensor extension harness, near T/O to oil pressure switch
S121	Fuel charge harness, near T/O to EGR valve position sensor
S122	Fuel charge harness, near T/O to fuel injector NO. 4
S123 (2.3L)	Engine harness, near T/O to octane adjust shorting bar
S123 (5.0L)	Engine harness, near T/O to clutch cycling pressure switch
S124	Engine harness, near T/O to C119
S125	Engine control sensor extension harness, near T/O to SPOUT check connector
S126	Engine control sensor extension harness, near T/O to C101
S127	Main harness, near T/O to C110
S128	Fuel charge harness, near T/O to C119
S129	Main harness, near T/O to windshield washer pump test connector
S130	Dash panel to headlamp junction harness, near T/O to left headlamp
S131	Engine control sensor extension harness, near T/O to crankshaft position sensor
S132	Engine harness, near T/O to VIP test connector C198
S133	Dash panel to headlamp junction harness, near T/O to low coolant switch
S134	Engine control sensor extension harness, near T/O to SPOUT check connector
S135	Engine control sensor extension harness, near T/O to C101
S136	Engine harness, near T/O to integrated control module
S137	Engine harness, near T/O to integrated control module
S138	Engine harness, near T/O to octane adjust shorting bar
S200	Main harness, near T/O to instrument panel dimming rheostat
S204	Main harness, near T/O to instrument panel dimming rheostat
S205	Radio speaker jumper harness, near T/O to C257
S206	Main harness, near T/O to C276
S207	Main harness, near T/O to instrument panel dimming rheostat
S208	Main harness, near T/O to instrument panel dimming rheostat
S209	Main harness, near T/O to C201
S210	Main harness, near T/O to instrument panel dimming rheostat
S211	Main harness, near T/O to blower motor switch
S212	Main harness, near T/O to C201

SATISFACTION 100% GUARANTEED

BUY IT NOW!

Click Here To Order

PayPal American Express Discover MasterCard VISA

<u>Splice</u>	<u>Location</u>
S216	Main harness, near T/O to engine indicator diode
S217	Engine harness, near T/O to electronic engine control (EEC) module
S218	Main harness, near T/O to low oil warning relay
S220	Main harness, near T/O to C251
S221	Main harness, near T/O to blower motor
S222	Main harness, near T/O to C201
S223	Main harness, near T/O to C251
S224	Window regulator relay switch harness, near T/O to C204
S225	Window regulator relay switch harness, near T/O to C204
S226	Main harness, near T/O to C204
S227	Main harness, near T/O to engine indicator diode
S228	Main harness, near T/O to C213
S229	Main harness, near T/O to blower motor resistor assembly
S230	Radio speaker jumper harness, near T/O to radio
S231	Window regulator left front harness, near T/O to C227
S301	Rear lamp harness, near T/O to convertible top motor
S302	Rear lamp harness, near T/O to fuel pump relay
S303	Interior lamp feed harness, near T/O to right vanity mirror lamp
S304	Rear lamp harness, near T/O to G300
S305	Rear lamp harness, near T/O to rear crash sensor
S400	Rear lamp harness, near T/O to right backup lamp
S401	Rear lamp harness, near T/O to left rear park/stop lamp
S402	Rear license lamp harness, in T/O to left license lamp
S403	Rear lamp harness, near T/O to right rear park/stop lamp
S404	Rear license lamp harness, near T/O to left license lamp
S408	Rear lamp harness, near T/O to C403
S411	Rear lamp harness, near T/O to left backup lamp
S412	Rear lamp harness, near T/O to left rear park/stop lamp
S500	Window regulator left front door harness, near T/O to master window control switch
S600	Window regulator right front door harness, near T/O to C601
S601	Window regulator right front door harness, near T/O to C601



BUY IT NOW!

Click Here To Order 







160-1 VEHICLE REPAIR LOCATION CODES

VEHICLE REPAIR LOCATION CODES

TO PINPOINT THE ACTUAL VEHICLE LOCATION OF A REPAIR, THE VEHICLE REPAIR LOCATION CODE IS REQUIRED.

FOR EXAMPLE, AN "X" HAS BEEN PLACED IN THE QUADRANT OF THE VEHICLE DIAGRAMS INDICATING THE LOCATION OF THE REPAIR. SEE DIAGRAMS.

LOCATION CODE, FOR THE EXAMPLE IS: A5/FU — (UNDER THE FLOOR OF DRIVER'S LEFT FOOT.)

FRONT/REAR DIRECTION

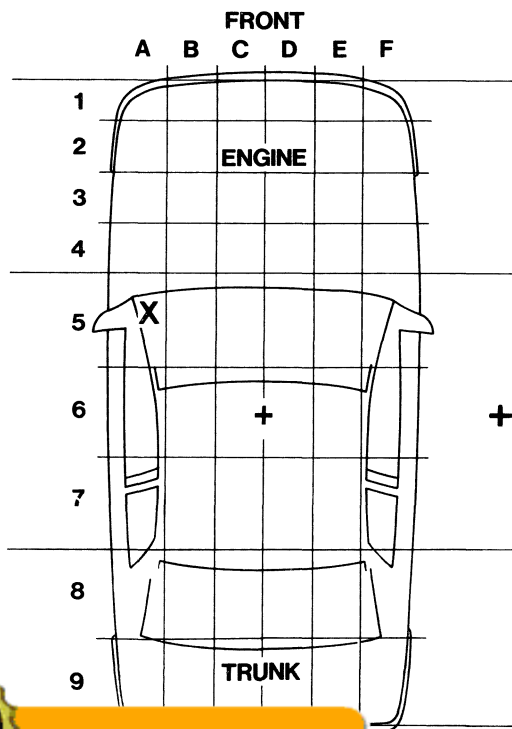

OVER/UNDER DIRECTION

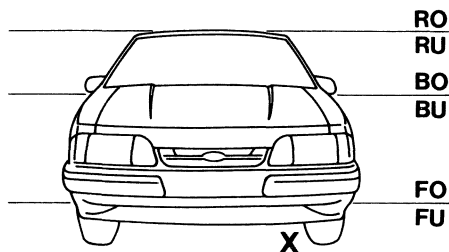

- R = ROOF LINE
- RO = ROOF OVER
- RU = ROOF UNDER
- B = BELT LINE
- BO = BELT OVER
- BU = BELT UNDER
- F = FLOOR PAN
- FO = FLOOR OVER
- FU = FLOOR UNDER

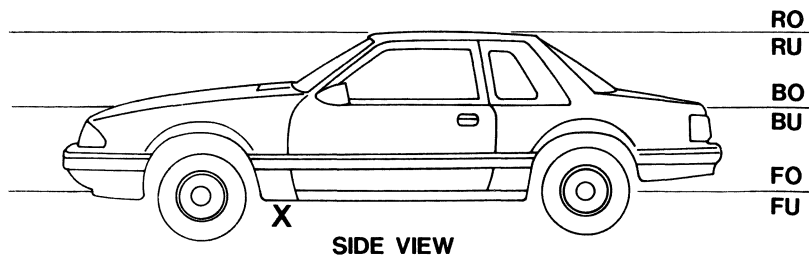

SIDE VIEW

MUSTANG
FPS-12121-91

100% SATISFACTION GUARANTEED

BUY IT NOW!

Click Here To Order

We Want To Hear From You!

Tell us about yourself

Are you a: Ford Trained Technician Independent Technician Customer
 Other _____

1. Which section of the EVTMM do you use most frequently?

Schematics Diagnostics Component Location Information

2. How often do you refer to this Ford Service Publication?

For all electrical problems
 For about 75% of electrical problems
 Fewer than 25% of electrical problems

3. Do the component location descriptions provide enough detail?

Yes No

Suggestions: _____

4. Would you prefer to have the electrical information for one vehicle, in one publication (separate electrical publications for each vehicle)?

Yes No

5. Are connector views and corresponding information helpful when diagnosing electrical problems?

Yes No

6. Would you like to include more component switch test information?

Yes No

7. Do you read the "How to Use this Manual" and "How to Find the Electrical Problems" sections of this manual?

Yes No

What additional information would be helpful? _____

8. Rate the purpose for using the location index. (5 is high, 1 is low)

Connectors Splices Part Numbers Grounds

9. Are the full view, more comprehensive illustrations (located just prior to the Location Index) a helpful tool?

Yes No

Comment: _____

10. Please rate the overall effectiveness of the revised radio schematics and diagnostics.

Good Fair Poor

11. How helpful are the "equivalent circuits" of electrical components, as shown on schematics, when troubleshooting electrical circuits?

Fair Poor

Comments: _____



BUY IT NOW!

Click Here To Order



DO NOT STAPLE — USE TRANSPARENT TAPE

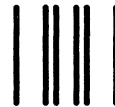

NO POSTAGE
NECESSARY
IF MAILED
IN THE
UNITED STATES

BUSINESS REPLY MAIL
FIRST CLASS PERMIT NO. 400 DEARBORN, MICH.

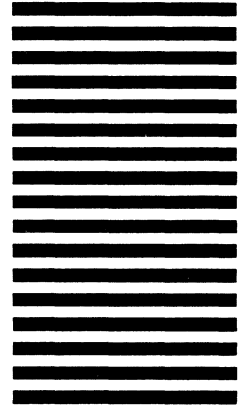

POSTAGE WILL BE PAID BY ADDRESSEE

Ford Parts and Service Division
Service Publications-ART
Room 2009
Post Office Box 1902
3000 Schaefer Road
Dearborn, Michigan 48121



BUY IT NOW!
Click Here To Order 





**WE SUPPORT VOLUNTARY
TECHNICIAN CERTIFICATION**



**Service
Publications**

Ford Parts and Service Division

**SATISFACTORY
100%
GUARANTEED**

BUY IT NOW!

Click Here To Order

PayPal

FPS-12121-91
Copyright © 1990
Ford Motor Company