

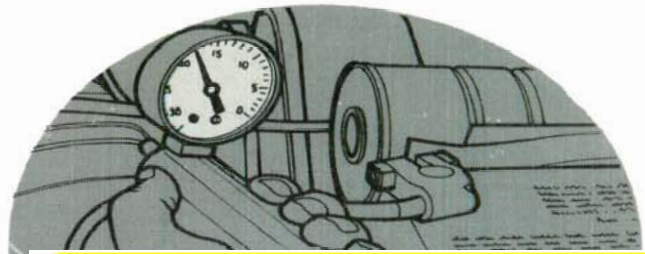

Click Here To Order

BUY IT NOW!



DEMO

This DEMO contains only a few pages of the entire manual/product.

Not all Bookmarks work on the Demo, but they do on the full version.

Features:

- Searchable text
- Printable pages
- Bookmarked for easy navigation
- High Resolution images
- Zoom to see exact details
- Money back Guarantee
- Available on USB and eBook download

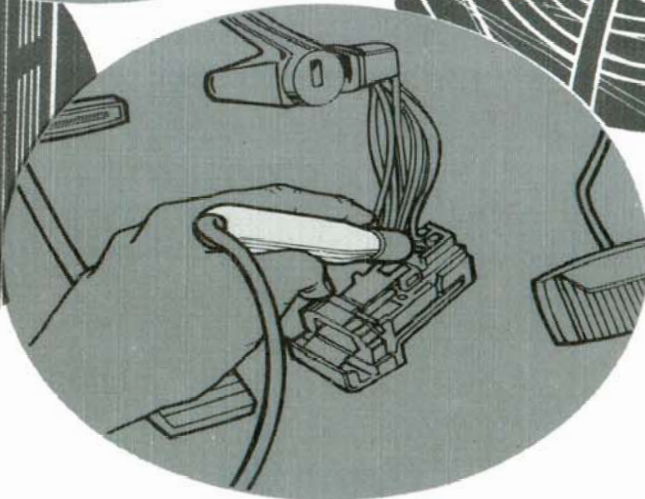
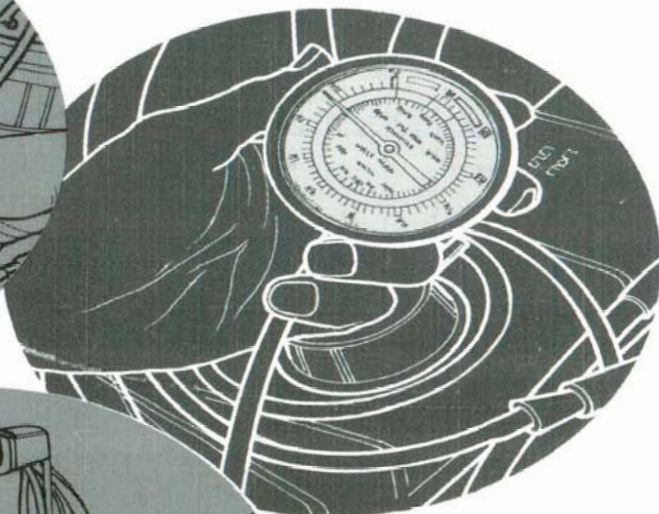
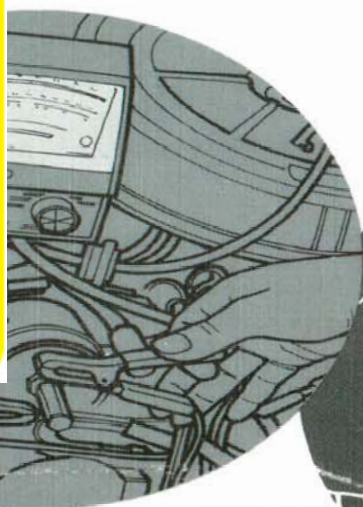

1988 MUSTANG

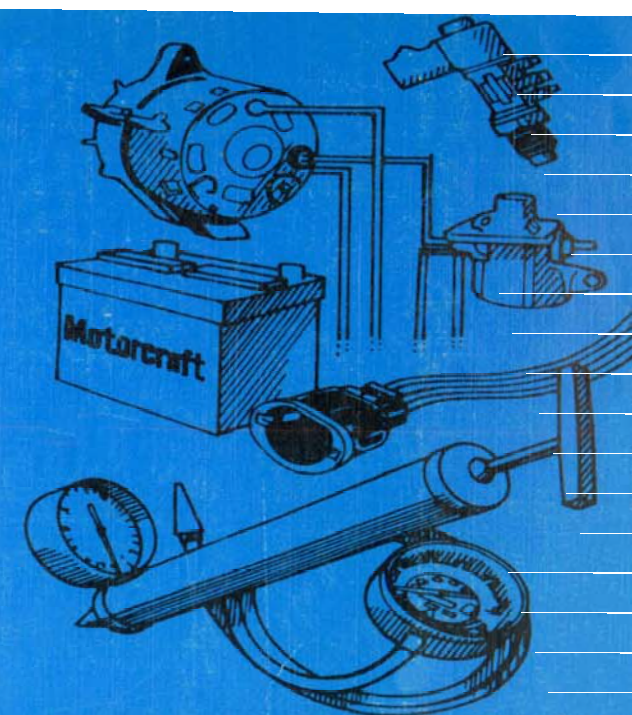

Electrical & Vacuum Trouble-Shooting Manual

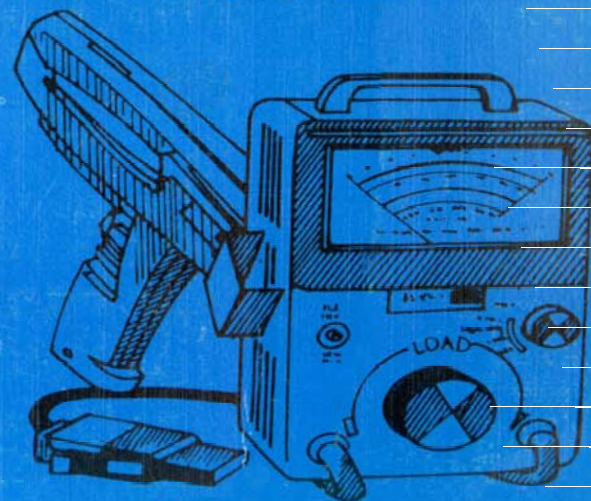

Official Licensed Product

License #84356800

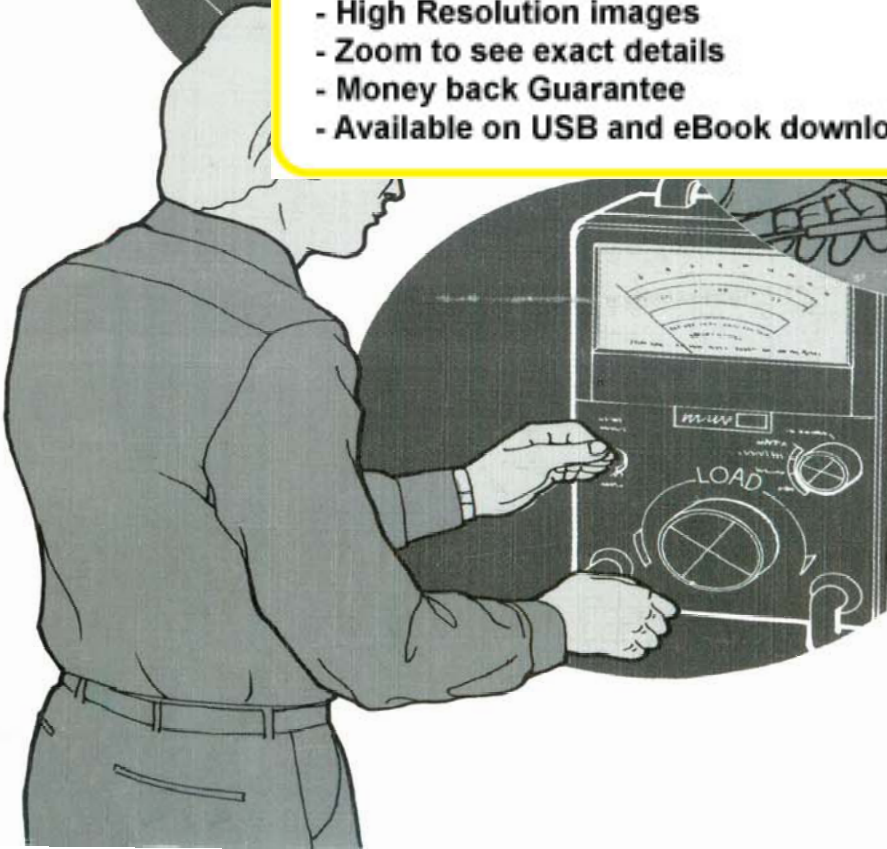

Copyright © 2023, Forel Publishing Company, LLC, Woodbridge, Virginia

All Rights Reserved. No part of this book may be used or reproduced in any manner whatsoever without written permission of Forel Publishing Company, LLC. For information write to Forel Publishing Company, LLC, Woodbridge, VA 22192

**1988 Mustang Electrical & Vacuum
Trouble-Shooting Manual (EVTM)
EAN: 978-1-60371-399-3
ISBN: 1-60371-399-9**

Forel Publishing Company, LLC
Woodbridge, VA 22192
Email: sales@ForelPublishing.com
<https://www.ForelPublishing.com>



This publication contains material that is reproduced and distributed under a license from Ford Motor Company. No further reproduction or distribution of the Ford Motor Company material is allowed without the express written permission of Ford Motor Company.

Note from the Publisher

This product was created from the original Ford Motor Company's publication. Every effort has been made to use the original scanned images, however, due to the condition of the material; some pages have been modified to remove imperfections.

Disclaimer

Although every effort was made to ensure the accuracy of this book, no representations or warranties of any kind are made concerning the accuracy, completeness or suitability of the information, either expressed or implied. As a result, the information contained within this book should be used as general information only. The author and Forel Publishing Company, LLC shall have neither liability nor responsibility to any person or entity with respect to any loss or damage caused, or alleged to be caused, directly or indirectly by the information contained in this book. Further, the publisher and author are not engaged in rendering legal or other professional services. If legal, mechanical, electrical, or other expert assistance is required, the professional should be sought.



ELECTRICAL AND VACUUM TROUBLESHOOTING MANUAL

FPS — 12121 - 88

ORDER INFORMATION

Information on how to order additional copies of this publication or other Ford publications, may be obtained by writing to Helm Incorporated at the address shown below. Other publications available include:

- Shop Manuals
- Service Specification Books
- Car/Truck Wiring Diagram Books
- Engine/Emissions Diagnosis Manuals

Helm Incorporated
P.O. Box 07150
Detroit, Michigan 48207



BUY IT NOW!

Click Here To Order



TABLE OF CONTENTS

How to Use This Manual	1
How to Find the Electrical Problem	2
Symbols (Electrical)	4
(Vacuum)	102
How to Find the Vacuum Problem	103
Instrument Panel Wiring	117
Component Testing	
A/C-Heater Function Control	124
Blower Switch	125
I/P Dimmer Switch	119
Fog Lamp Switch	119
Hazard Switch	123
Ignition Switch	120
Introduction	119
Interval Wiper/Washer Switch	122
Main Light Switch	119
Multi-Function Switch	121
Location Index	126

INDEX

A/C-Heater (Electrical)	109
A/C-Heater (Vacuum)	116
Charge	12
Cigar Lighter	81
Circuit Protection	10
Compressor Clutch Control	112
Convertible Top	92
Cooling Fan Control	112
Liftgate/Decklid Release	90
Electronic Engine Control (EEC)	26
Fuel Filler Door Release	91
Fuse Panel	10
Gauges	43
Grounds	5
Heater (Electrical)	107
Heater (Vacuum)	115
.....	81
.....	21
.....	78
.....	43
.....	78

Lamps:	
Backup	59
Cargo	62
Courtesy	62
Dome	63
Exterior	52
Fog Lamps	49
Glove Compartment	62
Hazard	54
Headlamps	49
Instrument Illumination	60
License	52
Luggage Compartment	62
Map	63
Marker	52
Park (Front)	52
Rear Park (Tail)	52
Stop	54
Turn	54
Underhood	62
Vanity Mirror	63
Low Fluid Warning	43
Lumbar Seats	76
Main Light Switch	16
Power Distribution	12
Power Door Locks	68
Power Outside Mirrors	74
Power Windows (2-Door & 3-Door)	70
Power Windows (Convertible)	71
Radio (Stereo)	94
Radio (Stereo with Premium Sound)	95
Radio (Stereo/Tape)	96
Rear Window Defrost	86
Seatbelt Warning	78
Speed Control	104
Start	21
Vacuum Distribution	101
Warning Indicators	13,43
Wiper/Washer (Interval)	83

IMPORTANT SAFETY NOTICE

Appropriate service methods and proper repair procedures are essential for the safe, reliable operation of all motor vehicles, as well as the personal safety of the individual doing the work. This Manual provides general directions for accomplishing service and repair work with tested, effective techniques. Following them will help assure reliability.

There are numerous variations in procedures, techniques, tools, and parts for servicing vehicles, as well as in the skill of the individual doing the work. This Manual cannot possibly anticipate all such variations and provide advice or cautions as to each. Accordingly, anyone who departs from the instructions provided in this Manual must first establish that he compromises neither his personal safety nor the vehicle integrity by his choice of methods, tools or parts.

This manual contains the following diagnostic information:

- Electrical and Vacuum Schematics
- Component Location Indexes and Views
- Troubleshooting Hints
- Descriptions of Circuit Operation
- Component Testing

The vehicle's entire electrical system is broken down into individual systems. There are also sections for the vehicle's ground and power distribution circuitry. Each system section begins with a wiring schematic. The **Schematics** should always be your starting point in using this manual. These schematics show the paths of electrical current during proper circuit operation. The source of voltage (circuit breaker or fuse) is shown at the top of the page. All wire, connectors, splices, switches, and motors are shown in the flow of current to ground at the bottom of the page. Connector end views of switches and other components are shown to help with bench testing. Each circuit component is named (underlined titles). Wire and connector colors are listed (standard Ford color abbreviations are used). These abbreviations are:

COLOR ABBREVIATIONS

BL	Blue	N	Natural
BK	Black	O	Orange
BR	Brown	PK	Pink
DB	Dark Blue	R	Red
DG	Dark Green	P	Purple
GR	Green	T	Tan
GY	Gray	W	White
L	Light Blue	Y	Yellow

The **Component Location** section of each system helps you locate the circuit's components in the vehicle. A brief statement of the location is given as well as a reference to an illustrative figure in the manual. There is also a full listing of connector, ground, and splice locations in the **Location Index** in the back of the manual.

OTHER ABBREVIATIONS

T/O (Tape Out) The point at which a harness branches to feed a component.

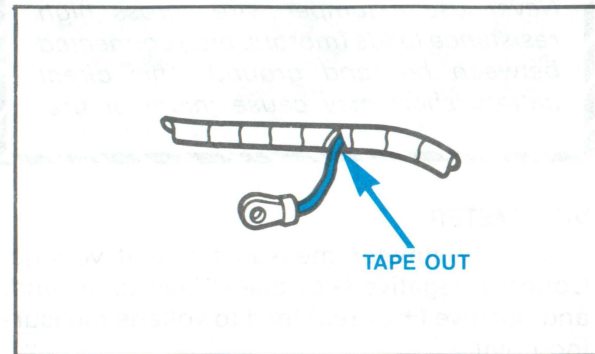

The **Troubleshooting Hints** offer shortcuts or tests that help you determine the cause of an electrical problem. They are not intended to be a rigid procedure for solving an electrical situation. Rather, Troubleshooting Hints represent a common-sense approach that is based on an understanding of the circuit.

A description of **How the Circuit Works** is written to help you understand the operation of the circuit as a whole. Emphasis is placed on how the components and circuitry interact in a properly working system.

A **Component Testing** section provides procedures to determine whether a component is good or bad.

Notes, Cautions, and Warnings appear in boxes on text pages and contain important car and mechanic safety information.

Notes give added information to help complete a particular procedure. Cautions are included to prevent making an error that could damage the vehicle. Warnings highlight areas where carelessness can cause personal injury. The following list contains some general **Warnings** that should be followed when working on a vehicle.

- Always wear safety glasses for eye protection.
- Use safety stands whenever a procedure requires being under a vehicle.
- Be sure that the **Ignition Switch** is always in the OFF position, unless otherwise required by the procedure.
- Set the parking brake when working on any vehicle. An automatic transmission should be in PARK. A manual transmission should be in NEUTRAL.
- Operate the engine only in a well-ventilated area to avoid the danger of carbon monoxide.
- Keep away from moving parts when the engine is running, especially the fan and belts.
- To prevent serious burns, avoid contact with hot metal parts such as the radiator, exhaust manifold, tail pipe, catalytic converter, and muffler.
- Do not allow flame or sparks near the battery. Gases are always present in and around the battery cell. An explosion could occur.
- Do not smoke.
- To avoid injury, always remove rings, watches, loose hanging jewelry, and loose clothing.

100% SATISFACTION GUARANTEED

BUY IT NOW!

Click Here To Order

PayPal, American Express, Discover, MasterCard, VISA

2 HOW TO FIND THE ELECTRICAL PROBLEM

TROUBLESHOOTING STEPS

These six steps present an orderly method of troubleshooting:

Step 1. Verify the problem.

- Operate the complete system and see all symptoms for yourself in order to:
 - check the accuracy and completeness of the customer's complaint.
 - learn more that might give a clue to the nature and location of the problem.

Step 2. Narrow the problem.

- Using the EVTMM, narrow down the possible causes and locations of the problem in order to more quickly find the exact cause.
- Read the description of *How the Circuit Works* and study the wiring diagram. You should then know enough about the circuit operation to figure out where to check for this trouble.

Step 3. Test the cause.

- Use electrical test procedures to find the specific cause of the symptoms.
- *Troubleshooting Hints* will give some helpful ideas.
- The *Component Location* charts and the pictures will help you find components, grounds, and connectors.

Step 4. Verify the cause.

- Confirm the fact that you have found the correct cause through operating the parts of the circuit you think are good.

Step 5. Make the repair.

- Repair or replace the faulty component.

Step 6. Verify the repair.

- Operate the system as in Step 1 and check for all symptoms, including any new

details. You will find the circuits in this manual to be helpful with these special tests.

TROUBLESHOOTING TOOLS

JUMPER WIRE

This is a test lead used to connect two points of a circuit. A **Jumper Wire** can complete a circuit by bypassing an open.

Uses: Bypassing Switches or Open Circuits

WARNING

Never use a jumper wire across high resistance loads (motors, etc.) connected between hot and ground. This direct battery short may cause injury or fire.

VOLTMETER

A DC **Voltmeter** measures circuit voltage. Connect negative (- or black) lead to ground, and positive (+ or red) lead to voltage measuring point.

OHMMETER

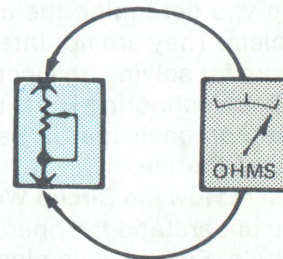

Figure 1—Resistance Check

An **Ohmmeter** shows the resistance between two connected points (Figure 1).

TEST LAMP

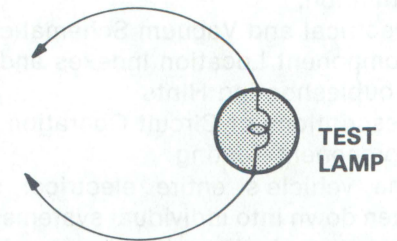

Figure 2—Test Lamp

A **Test Lamp** is a 12-volt bulb with two test leads (Figure 2).

Uses: Voltage Check. Short Check

SELF-POWERED TEST LAMP

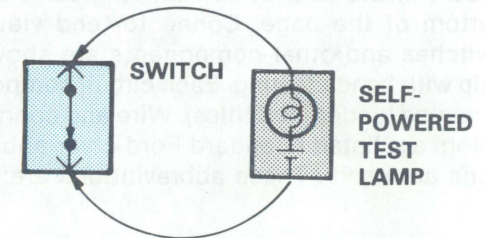

Figure 3—Continuity Check

The **Self-Powered Test Lamp** is a bulb, battery and set of test leads wired in series (Figure 3). When connected to two points of a continuous circuit, the bulb glows.

Uses: Continuity Check. Ground Check

CAUTION

When using a self-powered test lamp or ohmmeter, be sure power is off in circuit during testing. Hot circuits can cause equipment damage and false readings.

100% SATISFACTION GUARANTEED

BUY IT NOW!

Click Here To Order

PayPal American Express Discover MasterCard VISA

TROUBLESHOOTING CHECKS

SWITCH CIRCUIT CHECK

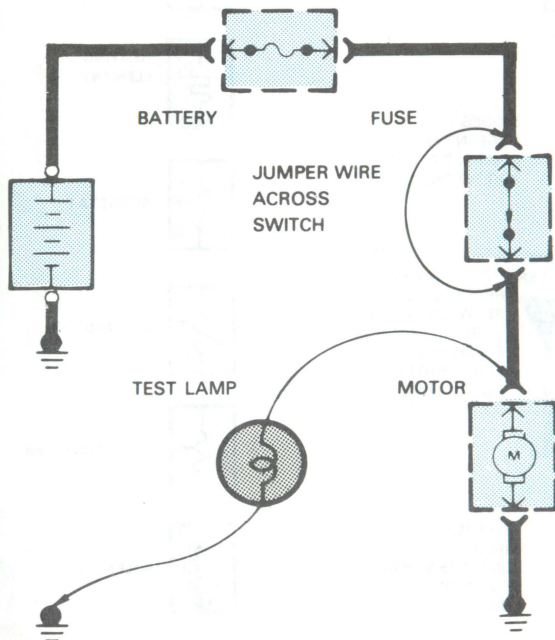

Figure 4—Switch Circuit Check and Voltage Check

In a bad circuit with a switch in series with the load, jumper the terminals of the switch to power the load. If jumping the terminals powers the circuit, the switch is bad (Figure 4).

CONTINUITY CHECK (Locating open circuits)

Connect one lead of **Self-Powered Test Lamp** or **Ohmmeter** to each end of circuit (Figure 3). Light will glow if circuit is closed. Switches and fuses can be checked in the same way.

VOLTA

own battery other the

SHORT CHECK (short to ground)

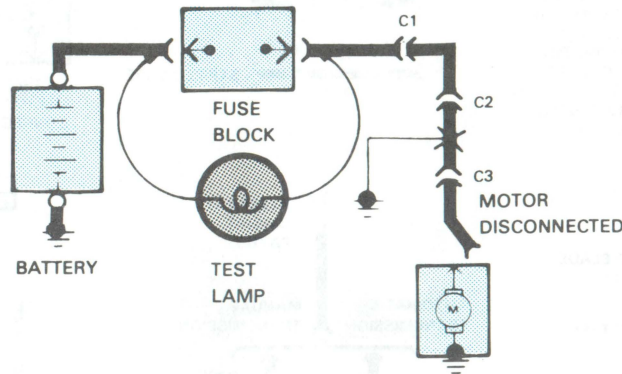

Figure 5—Short Check

A fuse that repeatedly blows is usually caused by a short to ground. It's important to be able to locate such a short quickly (Figure 5).

- 1) Turn off everything powered through the fuse.
- 2) Disconnect other loads powered through the fuse:
 - Motors: disconnect motor connector.
 - Lamps: remove bulbs.
- 3) Turn **Ignition Switch** to RUN (if necessary) to power fuse.
- 4) Connect one **Test Lamp** lead to hot end of blown fuse. Connect other lead to ground. Bulb should glow showing power to fuse. *(This step is just a check to be sure you have power to the circuit.)*
- 5) Disconnect the **Test Lamp** lead from ground and reconnect it to the load side of the fuse.
 - If the **Test Lamp** is off, the short is in the disconnected equipment.
 - If the **Test Lamp** goes on, the short is in the wiring. You must find the short by disconnecting the circuit connectors one at a time until the **Test Lamp** goes out. For example: with a ground at X, the bulb goes out when C1 or C2 is disconnected, but stays on after disconnecting C3. This

means the ground is between C2 and C3.

"GOOD GROUND" CHECK

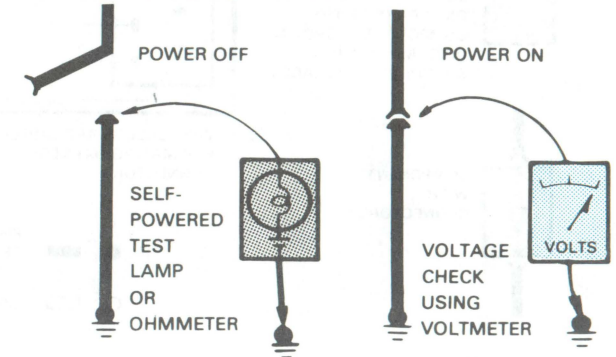

Figure 6—Grounds Checks

Turn on power to circuit. Perform Voltage Check between suspected bad ground and frame. Any voltage means ground is bad.

Turn off power to circuit. Connect one lead of **Self-Powered Test Lamp** or **Ohmmeter** to wire in question, and the other to known ground. If bulb glows, circuit ground is OK (Figure 6).

TROUBLESHOOTING HINTS

The circuit schematics in this manual are designed to make it easy to identify common points in circuits. This knowledge can help narrow the problem to a specific area. For example, if several circuits fail at the same time, check for a common power or ground connection. (See *Power Distribution* or *Grounds*). If part of a circuit fails, check the connections between the part that works and the part that doesn't work.

For example, if low beam **headlamps** work, but high beams and the indicator light don't work, then power and ground paths must be good. Since the dimmer switch is the component which switches this power to the high beam **lamps** and indicator, it is most likely the cause of failure.

100% SATISFACTION GUARANTEED

BUY IT NOW!

Click Here To Order

own battery other the

PayPal American Express Discover Novus MasterCard VISA

4 ELECTRICAL SYMBOLS

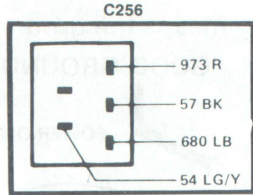
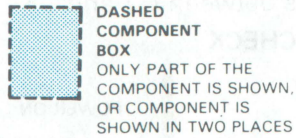

COMPONENT CONNECTOR END VIEW
SHOWS PINS OR SOCKETS ON A COMPONENT TO AID IN BENCH TESTING

WIRE COLORS ARE LABELED FOR MATING HARNESS CONNECTOR

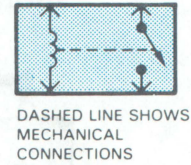
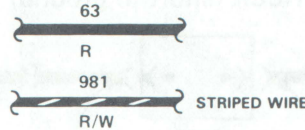
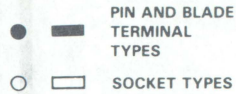

RELAY
CONTACTS CLOSE WITH CURRENT THROUGH COIL

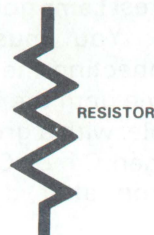
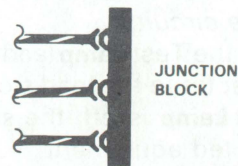
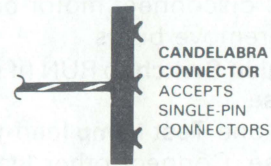
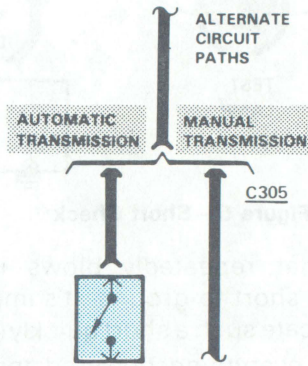
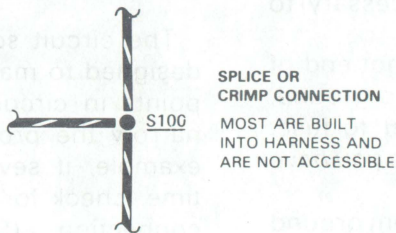
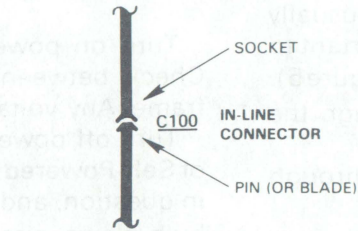
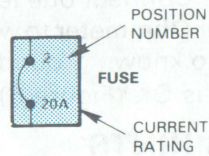
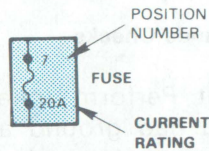
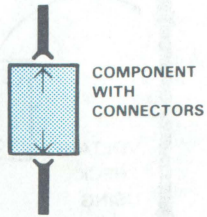
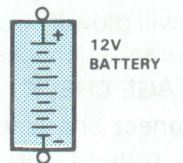
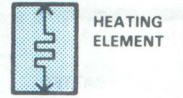
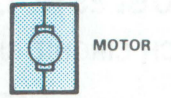

DIODES
CURRENT FLOWS IN DIRECTION OF ARROW ONLY

"CUT" WIRES
REFERENCED BETWEEN PAGES
ARROWS SHOW CURRENT FLOW FROM POWER TO GROUND

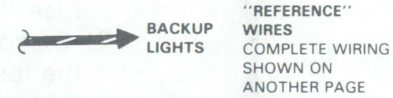

"REFERENCE" WIRES
COMPLETE WIRING SHOWN ON ANOTHER PAGE

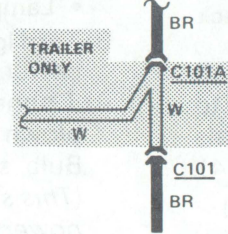

OPTIONAL WIRING
BR WIRES (INCLUDING C101 ARE ON ALL VEHICLES, BUT W WIRES (INCLUDING C101A) ARE USED ONLY WITH TRAILER

SEE GROUNDS PAGE 6, 7

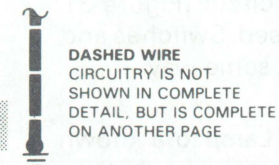

100% SATISFACTION GUARANTEED

BUY IT NOW!

Click Here To Order

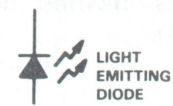
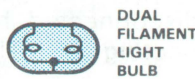

INSTRUMENT PANEL GROUND

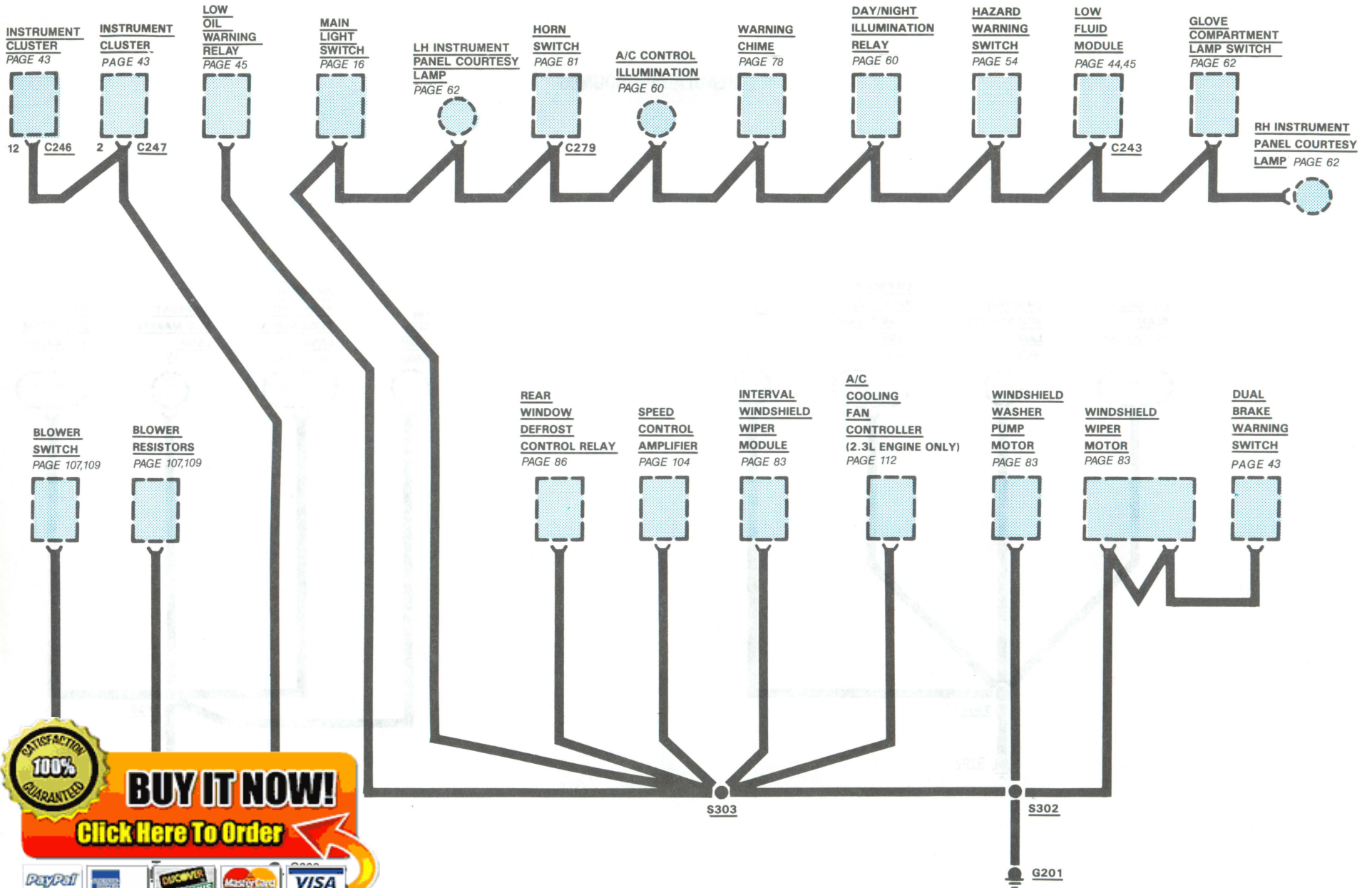

100% SATISFACTION GUARANTEED

BUY IT NOW!

Click Here To Order

PayPal American Express Discover MasterCard VISA

HEADLAMP GROUNDS

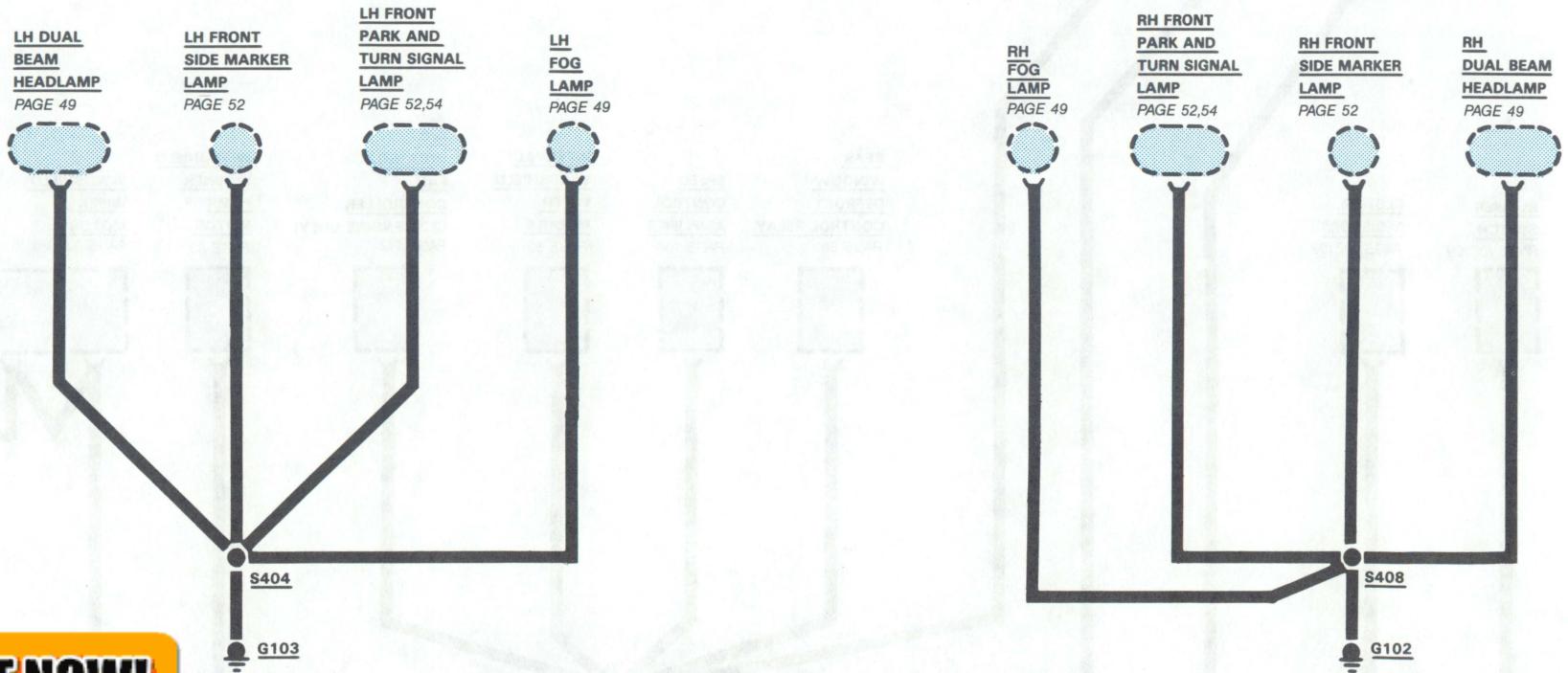

100% SATISFACTION GUARANTEED

BUY IT NOW!

Click Here To Order

PayPal American Express Discover MasterCard VISA

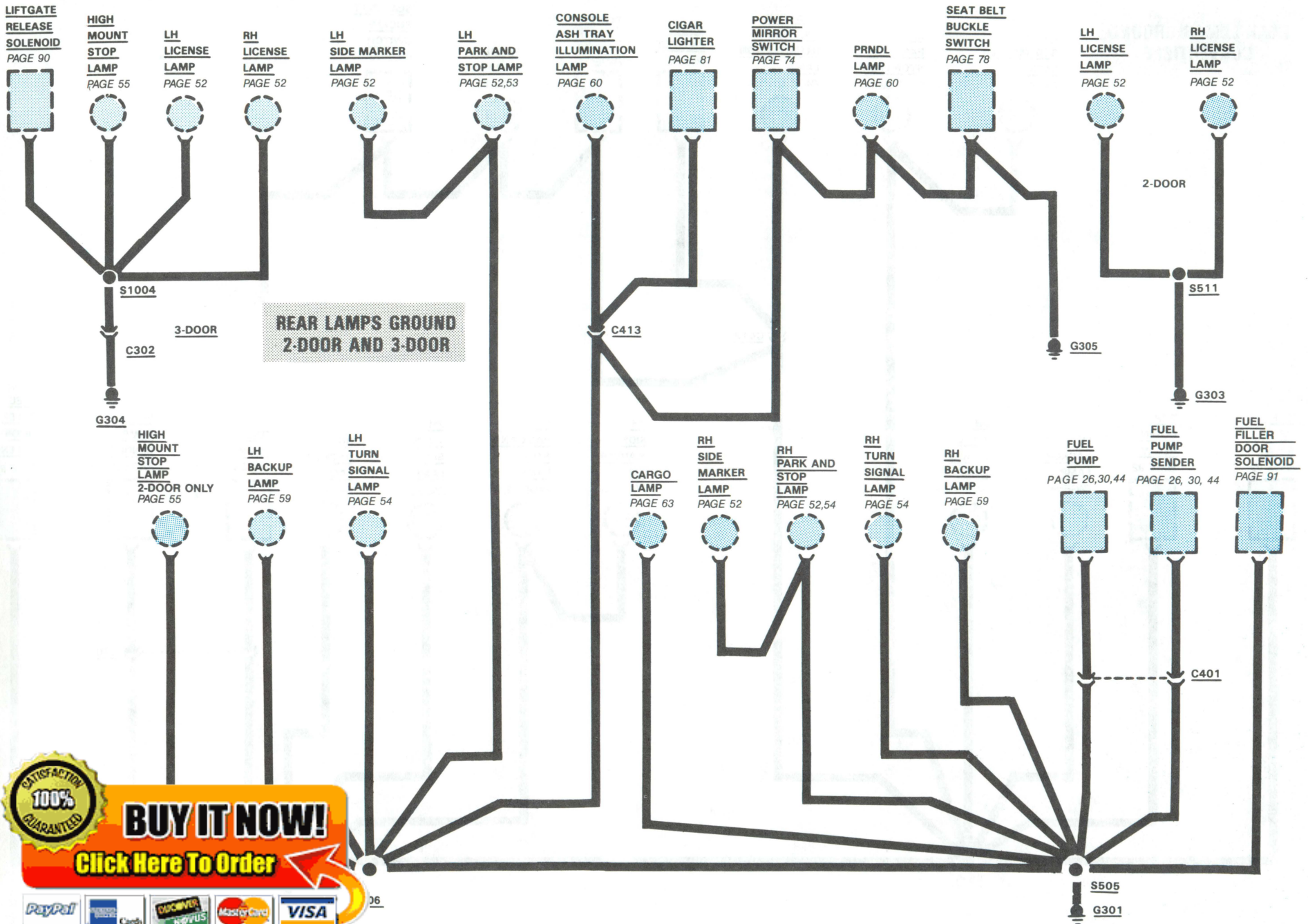

100% SATISFACTION GUARANTEED

BUY IT NOW!

Click Here To Order

06

REAR LAMPS GROUND CONVERTIBLE

LH SIDE MARKER LAMP
PAGE 52

LH PARK AND STOP LAMP
PAGE 52,54

CONSOLE ASH TRAY ILLUMINATION LAMP
PAGE 60

CIGAR LIGHTER
PAGE 81

POWER MIRROR SWITCH
PAGE 74

PRNDL LAMP
PAGE 60

SEAT BELT BUCKLE SWITCH
PAGE 78

TOP UP RELAY
PAGE 92

TOP DOWN RELAY
PAGE 92

LH BACKUP LAMP
PAGE 59

LH TURN SIGNAL LAMP
PAGE 54

RH SIDE MARKER LAMP
PAGE 52

RH PARK AND STOP LAMP
PAGE 52,54

RH TURN SIGNAL LAMP
PAGE 54

RH BACKUP LAMP
PAGE 59

FUEL PUMP
PAGE 26,30,44

FUEL PUMP SENDER
PAGE 26,30,44

FUEL FILLER DOOR SOLENOID
PAGE 91

100% SATISFACTION GUARANTEED

BUY IT NOW!

Click Here To Order

S506

S505

G301

C413

G305

C401

HOW THE CIRCUIT WORKS

The ground circuits shown here are complete, and connect several components together to screw terminal ground points. On other pages only parts of these circuits may be shown. Partial ground circuits are shown dashed on those pages.

All simple or component ground circuits are shown on the individual circuit pages, and are complete on those pages.

All wires are **57 BK** unless otherwise noted.

COMPONENT LOCATION

Page-
Figure

A/C Cooling Fan Controller	Attached to I/P support	
Blower Resistors	Under RH side of I/P	
Blower Switch	Part of heater function control	105-1
Dual Brake Warning Switch	LH fender apron	
Warning Chime	Behind center of I/P	80-1
Fuel Filler Door Solenoid ..	Under RH tail lamp assembly	
Fuel Pump	Part of fuel sender assembly	
Fuel Pump Sender	At fuel pump	
Interval Windshield Wiper Motor	Under LH side of I/P attached to shake brace	
Liftgate Release Solenoid	Part of liftgate latch assembly	
Low Oil Warning Relay ..	On LH I/P shake brace	
Main Light Switch	On LH side of I/P left of steering column	51-2
Rear Window Defrost Control Relay	LH side of I/P near fuse panel	
Speed Control Amplifier ..	LH cowl area	106-1
Top Up And Top Down Relays	In luggage compartment, behind rear seat	93-1
Windshield Wiper Motor ..	LH side of engine cowl	

Refer to the **Location Index** in the back of the manual for connector, ground, and splice descriptions and locations.

100% SATISFACTION GUARANTEED

BUY IT NOW!

Click Here To Order



10 FUSE PANEL/CIRCUIT PROTECTION

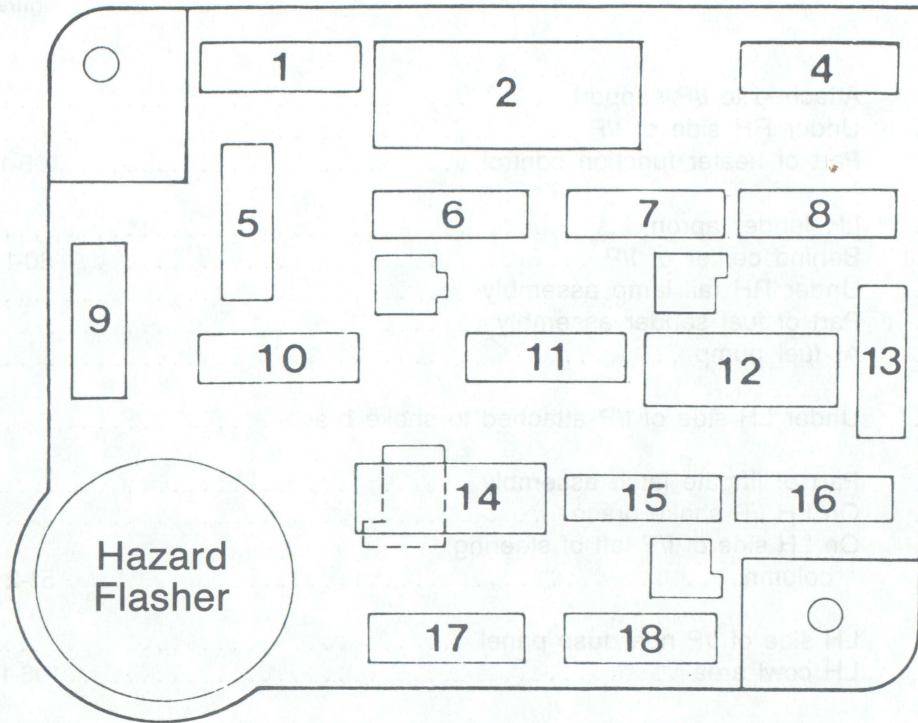

Fuse Position	Amps	Circuits Protected
1	15	Stop/Hazard Lamps; Speed Control
2	8.25 c.b.	Interval Wiper
4	15	Exterior Lamps; Instrument Illumination
5	15	Turn Lamps; Backup Lamps
6	20	Speed Control, Day/Night Illumination Relay; A/C; Decklid Release
7	—	(Not Used)
8	15	Courtesy Lamps; Dimmer Switch; Power Mirrors; Radio; Fuel Filler Door Release
9	30	Heater Blower ; A/C Blower
10	20	Headlamps; Low Oil Level Warning
11	15	Radio; Premium Sound; Graphic Equalizer
12	—	(Not Used)
13	5	Instrument Illumination
14	20 c.b.	Power Windows
15	15	Fog Lamps
16	20	Horn; Cigar Lighter
17	—	(Not Used)
18	15	Seatbelt Buzzer; Warning Indicators; Low Coolant Switch; Low Fluid Monitor; Instrument Cluster

Fuse Value Amps	Color Code
4	Pink
5	Tan

100% SATISFACTION GUARANTEED

BUY IT NOW!

Click Here To Order

Power Distribution

The **Alternator** and **Battery** are connected together at the **Starter Relay** hot terminal. Other circuits originate at the **Starter Relay** hot terminal and are protected by fuse links. Low power circuits are also protected by fuses.

The **Ignition Switch** and **Main Light Switch** are powered at all times, as are **Fuses 1, 4, 8, 10 and 16**. The other fuses are powered through the **Ignition Switch** or the **Main Light Switch**.

Position **3** is not used, and is covered by **Circuit Breaker 2**.

REPLACEMENT OF FUSES/ CIRCUIT BREAKERS

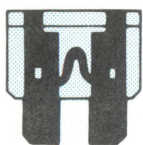

GOOD FUSE

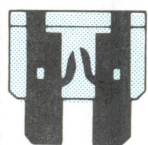

BLOWN FUSE

Fuses are mounted either in the **Fuse Panel** or in-line. They are identified by the numbered value in amperes, and by a color code. Some positions may have either a fuse with adapter or a circuit breaker. Be sure to replace a fuse or circuit breaker with the same kind of unit and with the same ampere rating. Remove fuses in order to check them.

CIRCUIT BREAKER OPERATION

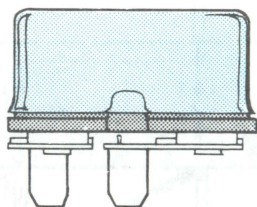

EXTERNAL
SIDE VIEW

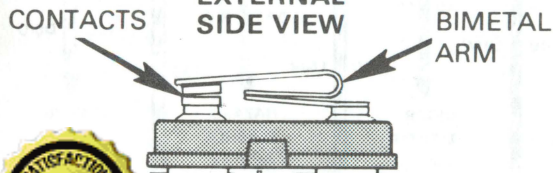

BIMETAL
ARM



BUY IT NOW!

Click Here To Order

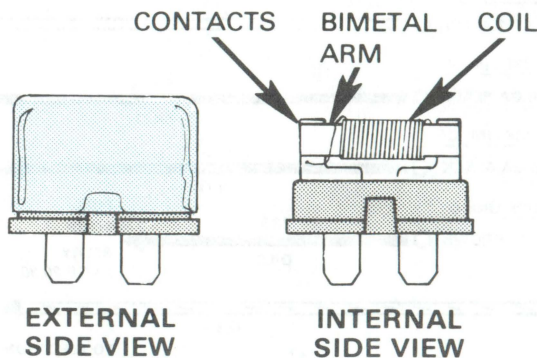

EXTERNAL
SIDE VIEW

INTERNAL
SIDE VIEW

Non-Cycling Fuse Panel Type

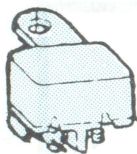

Cycling In-Line Type

Some circuits are protected by circuit breakers. (Abbreviated "c.b." in fuse chart.) They can be **Fuse Panel** mounted or in-line. Like fuses, they are rated in amperes.

Each circuit breaker conducts current through an arm made of two types of metal fastened together (bimetal arm). If the arm starts to carry too much current, it heats up. As one metal expands faster than the other the arm bends, opening the contacts. Current flow is broken. In the cycling type, the arm cools and straightens out. This closes the circuit again. This cycle repeats as long as the overcurrent exists, with power applied.

In the non-cycling type, there is also a coil wrapped around the bimetal arm. When an overcurrent exists and the contacts open, a small current passes through the coil. This current through the coil is not large enough to operate a load, but it does heat up both the coil and bimetal arm. This keeps the arm in the open position until power is removed.

FUSE LINKS

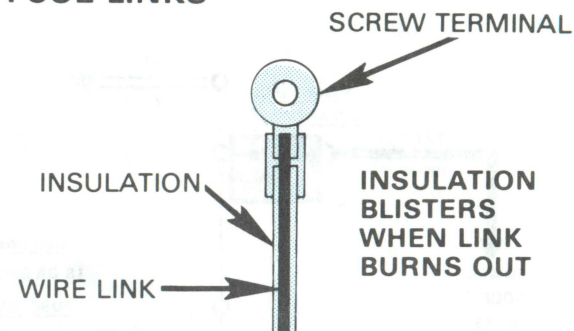

The fuse link is a short length of wire smaller in gage than the wire in the protected circuit. The wire is covered with a thick non-flammable insulation. An overload causes the link to heat and the insulation to blister. If the overload remains, the link will melt, causing an open circuit. The links are color coded for wire size as follows:

COLOR CODE

BLUE	20 GA
BROWN	18 GA
BLACK	16 GA
GREEN	14 GA

When replacing, make tight crimp joints or hot solder joints for good connections.

DIODES



Diodes are electrical devices that permit current to flow in one direction only. The current flows in the direction indicated by the arrow.

12 CHARGE/POWER DISTRIBUTION

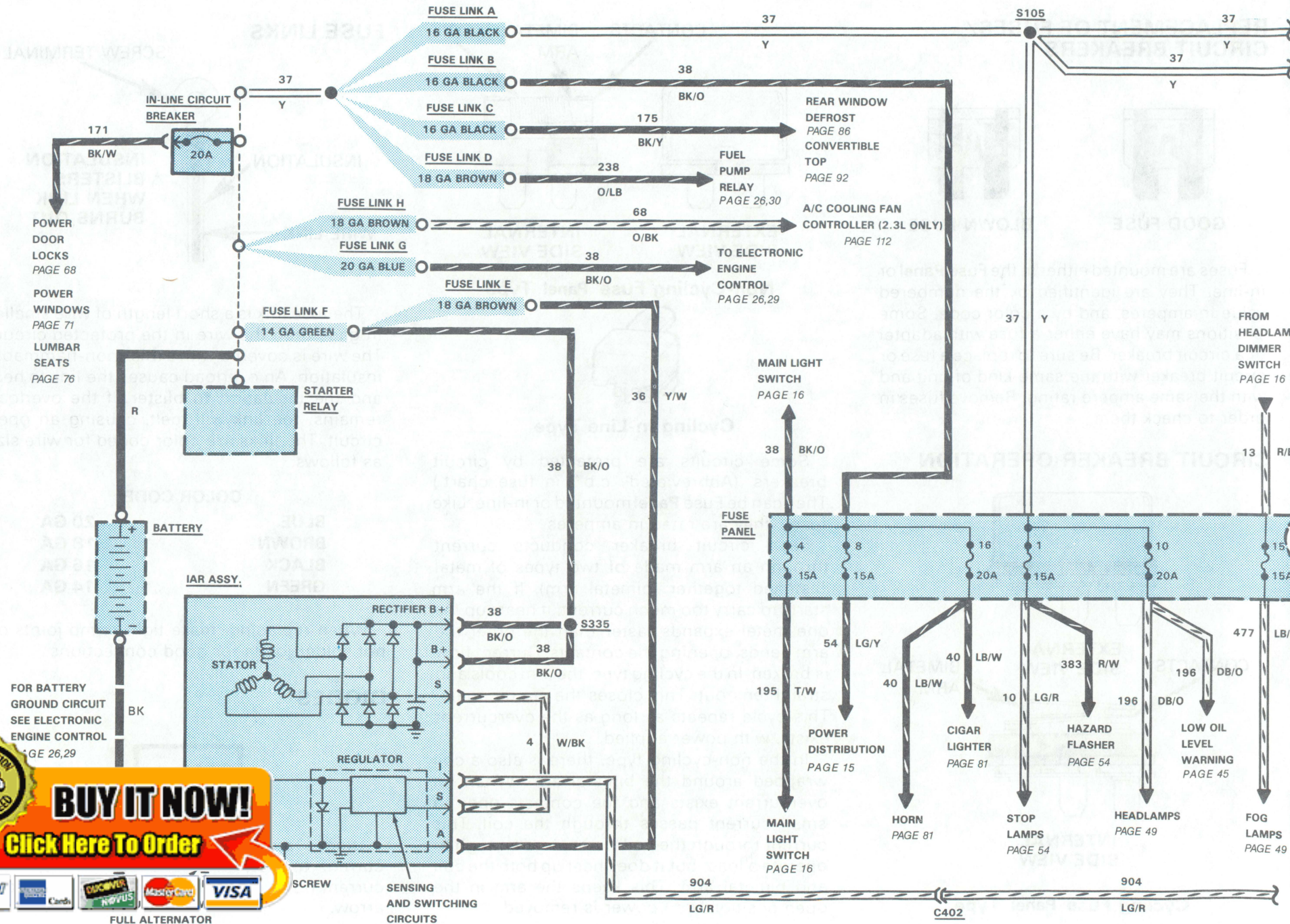

100% SATISFACTION GUARANTEED

BUY IT NOW!

Click Here To Order



FULL ALTERNATOR

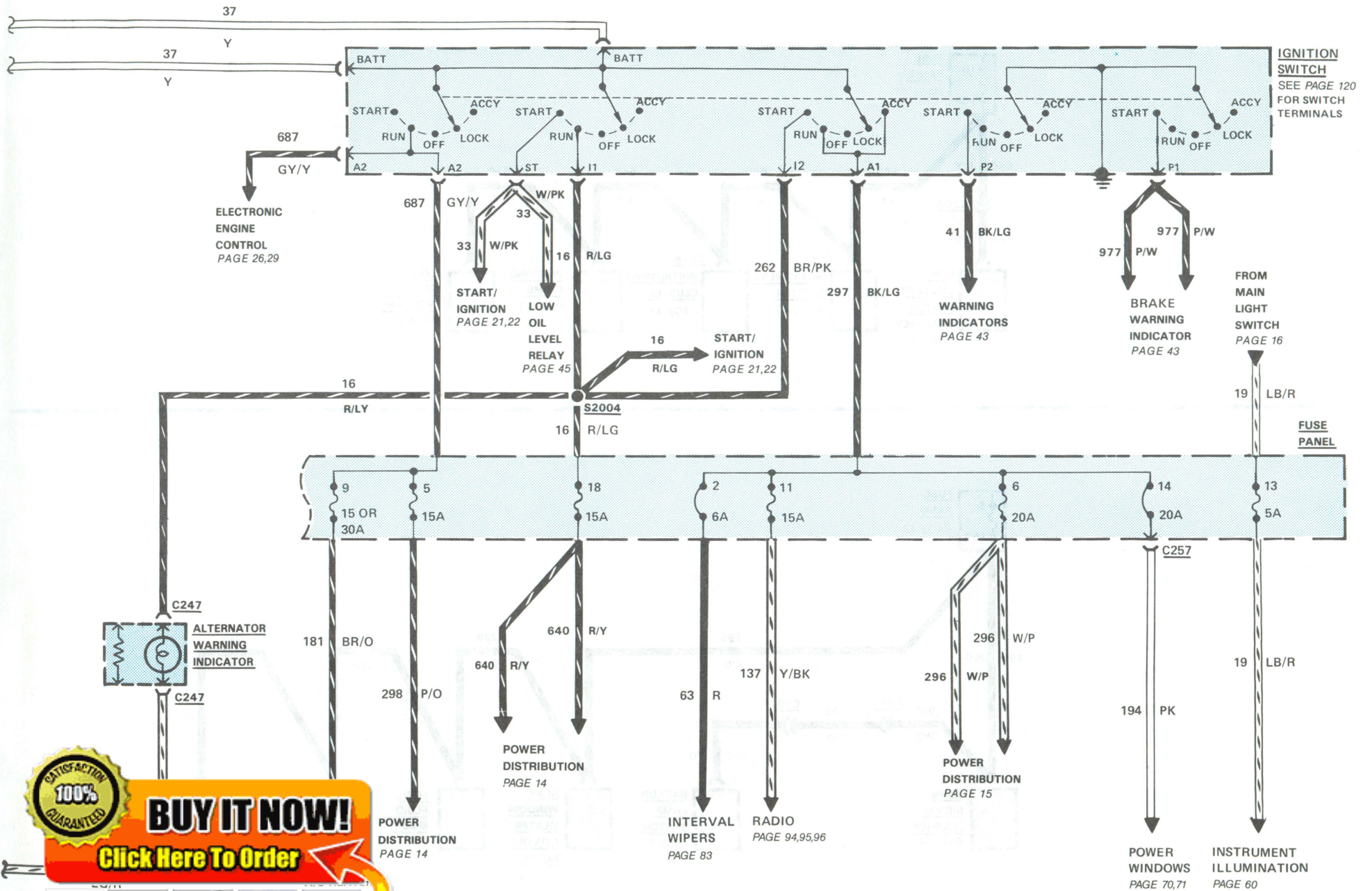

100% SATISFACTION GUARANTEED

BUY IT NOW!

Click Here To Order

14 POWER DISTRIBUTION (FUSE 18, FUSE 5)

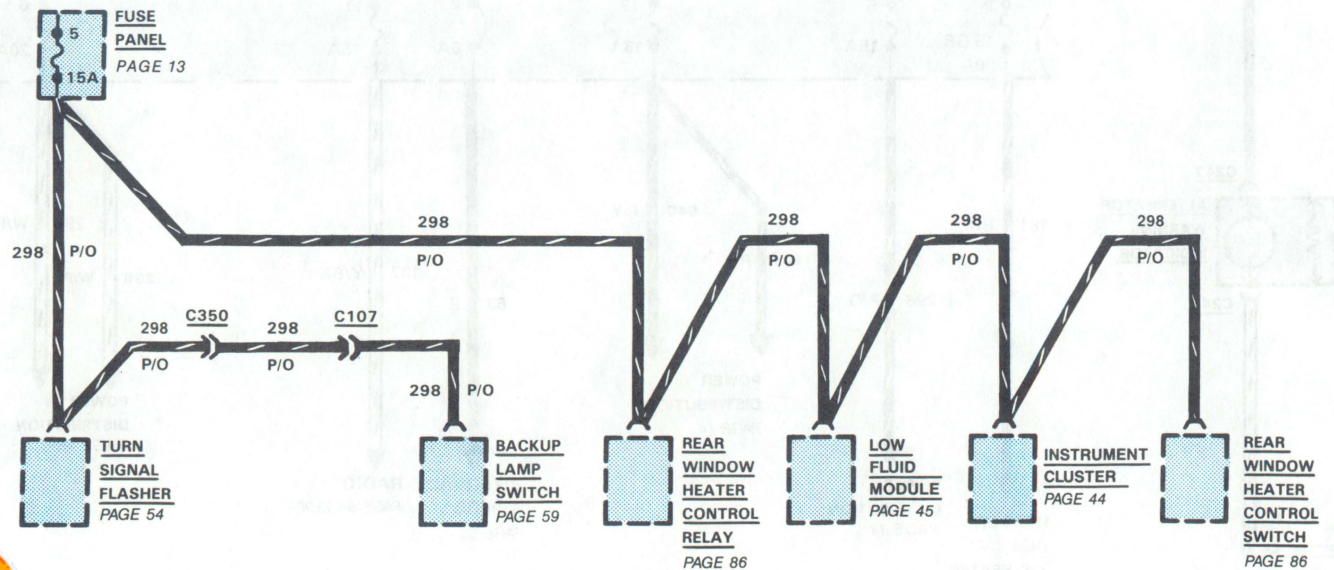
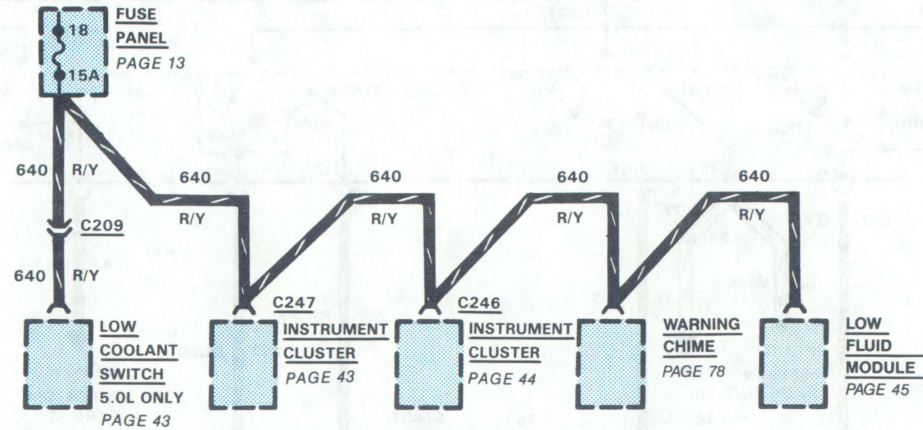

100% SATISFACTION GUARANTEED

BUY IT NOW!

Click Here To Order

PayPal

MasterCard

VISA

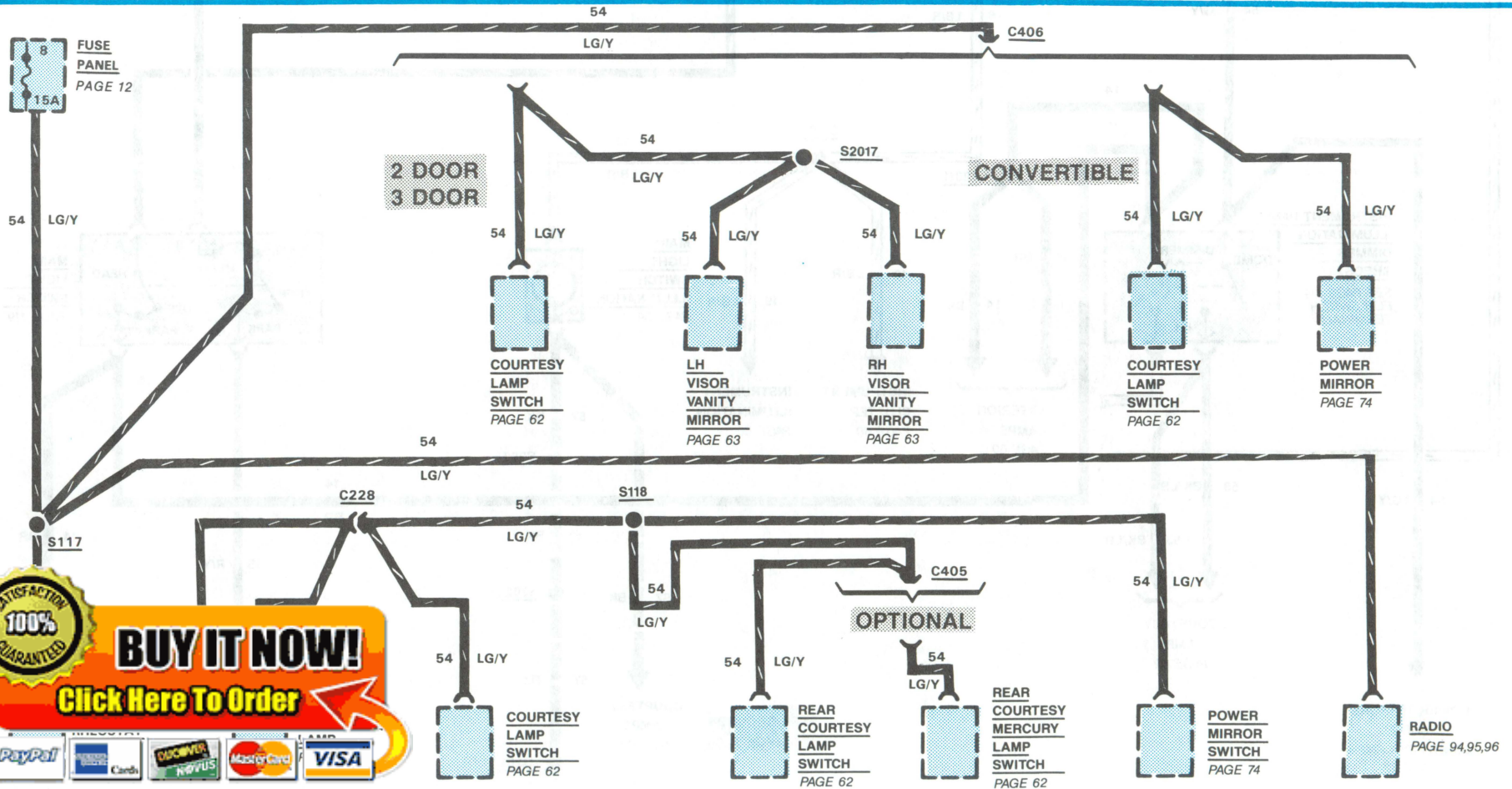
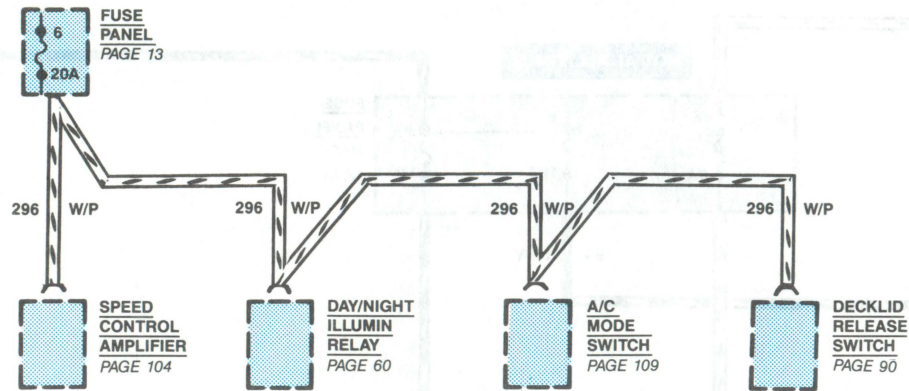

100% SATISFACTION GUARANTEED

BUY IT NOW!

Click Here To Order

16 CHARGE/POWER DISTRIBUTION (MAIN LIGHT SWITCH)

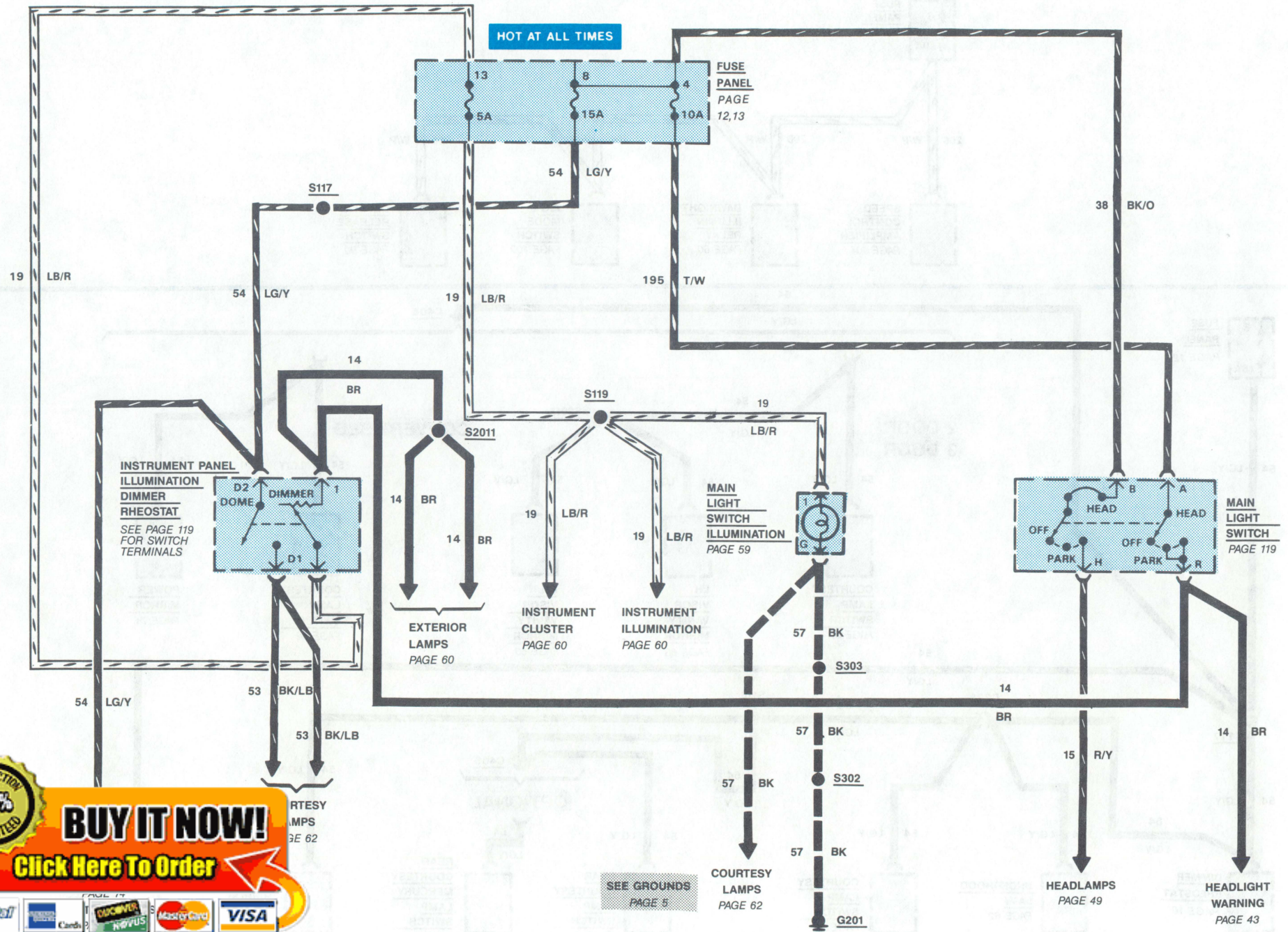

100% SATISFACTION GUARANTEED

BUY IT NOW!

Click Here To Order

HOW THE CIRCUIT WORKS

The **Battery**, **Alternator** and **Voltage Regulator** make up the **Charging System**.

With Alternator Warning Indicator

With the **Ignition Switch** in RUN, **Battery** current flows into the **Voltage Regulator** at terminal I and to ground through the solid-state regulator circuits. If the electronic control measures a low voltage at regulator terminal A it closes the field switch. This applies **Battery** voltage to the field.

With current in the field and the rotor turning, the **Alternator** stator produces an AC voltage. This is converted to DC by the rectifier assembly and is fed to terminal B (to **Battery**) and terminal S (stator). (Voltage at S is one-half voltage at B).

A pre-set voltage at terminal S operates the electronic control to open the indicator switch which removes ground from the **Alternator Warning Indicator** (through the heated windshield control modules, on models so equipped).

The **Alternator** output is controlled by the current in the field. The average voltage on the field depends on the percentage of time the field switch is closed. The electronic control closes the field switch when the voltage at A is low, and opens the switch when the voltage at A is high.

The **Voltage Regulator** holds the system voltage at about 14 volts. The average **Alternator** output is then any required value between zero and full current depending on conditions sensed by the **Voltage Regulator**.

COMPONENT LOCATION

Page-
Figure

Fuse Link A	At starter relay	18-1,19-2
Fuse Link B	At starter relay	18-1,19-2
Fuse Link C	At starter relay	18-1,19-2
Fuse Link D	LH fender apron	18-1,19-2
Fuse Link E	At starter relay	18-1,19-2
Fuse Link F	At starter relay	18-1,19-2
Fuse Link G	At starter relay	18-1
Fuse Link H	At starter relay	18-1

Refer to the **Location Index** in the back of the manual for connector, ground, and splice descriptions and locations.

TROUBLESHOOTING HINTS

CONDITION	POSSIBLE CAUSE	ACTION
<ul style="list-style-type: none"> Improper Charging 	<ul style="list-style-type: none"> Loose/worn alternator belt Defective/worn battery Fuse Link G open at starter relay Poor connection between battery terminals and cable clamps/damaged cables 	<ul style="list-style-type: none"> Tighten/replace belt Replace battery Visually check for open in link, replace Clean, tighten and/or replace
<ul style="list-style-type: none"> Alternator Warning Indicator remains on after initial start up 	<ul style="list-style-type: none"> Poor connection on Alternator, Regulator, Starter Relay, and/or Alternator Output Control Relay 	<ul style="list-style-type: none"> Make sure connections are tight and free of debris.



BUY IT NOW!

Click Here To Order







18 CHARGE/POWER DISTRIBUTION

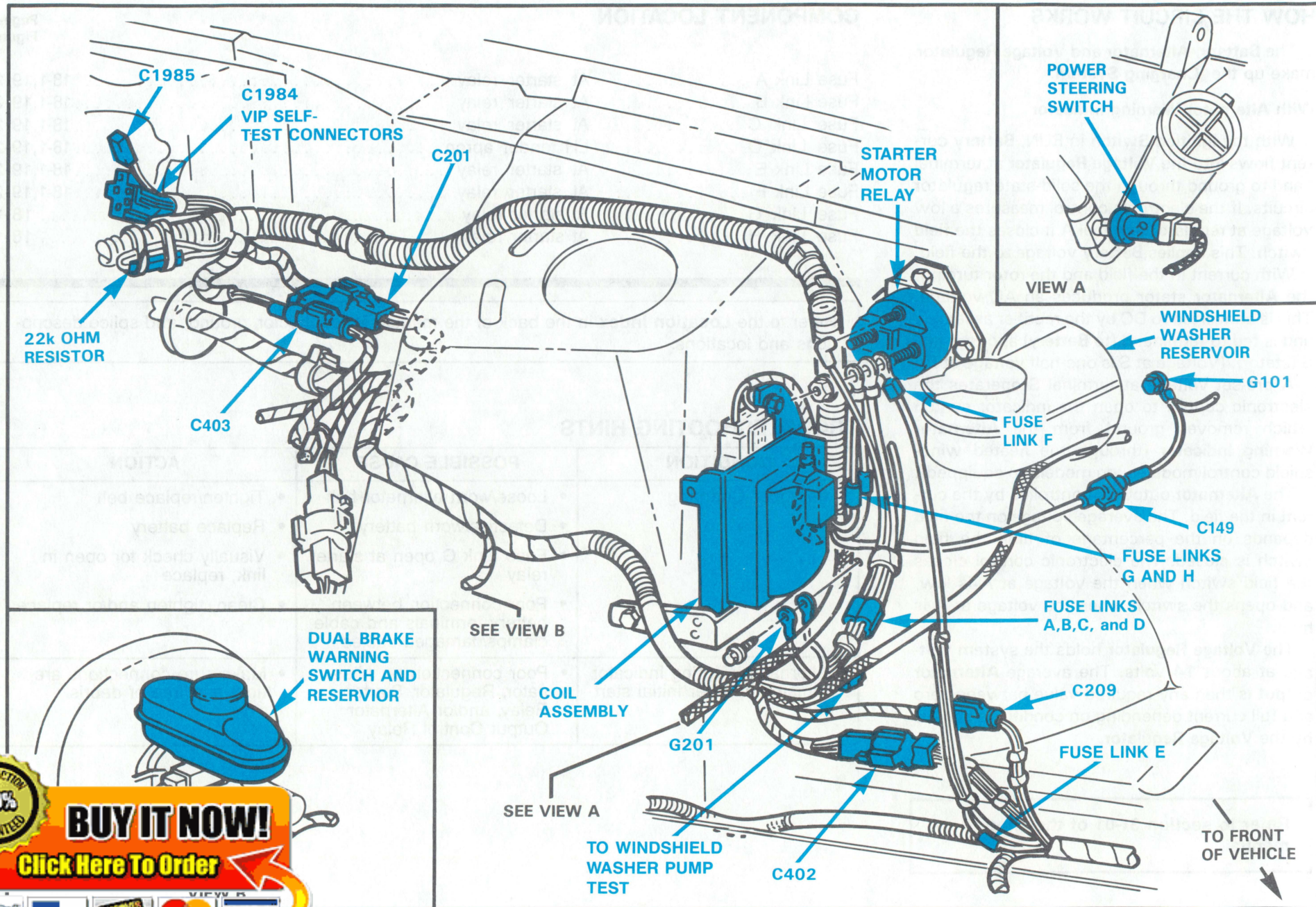

100% SATISFACTION GUARANTEED

BUY IT NOW!

[Click Here To Order](#)

VIEW B

PayPal | American Express | Discover | MasterCard | VISA

Figure 1- LH Fender Apron (2.3L)

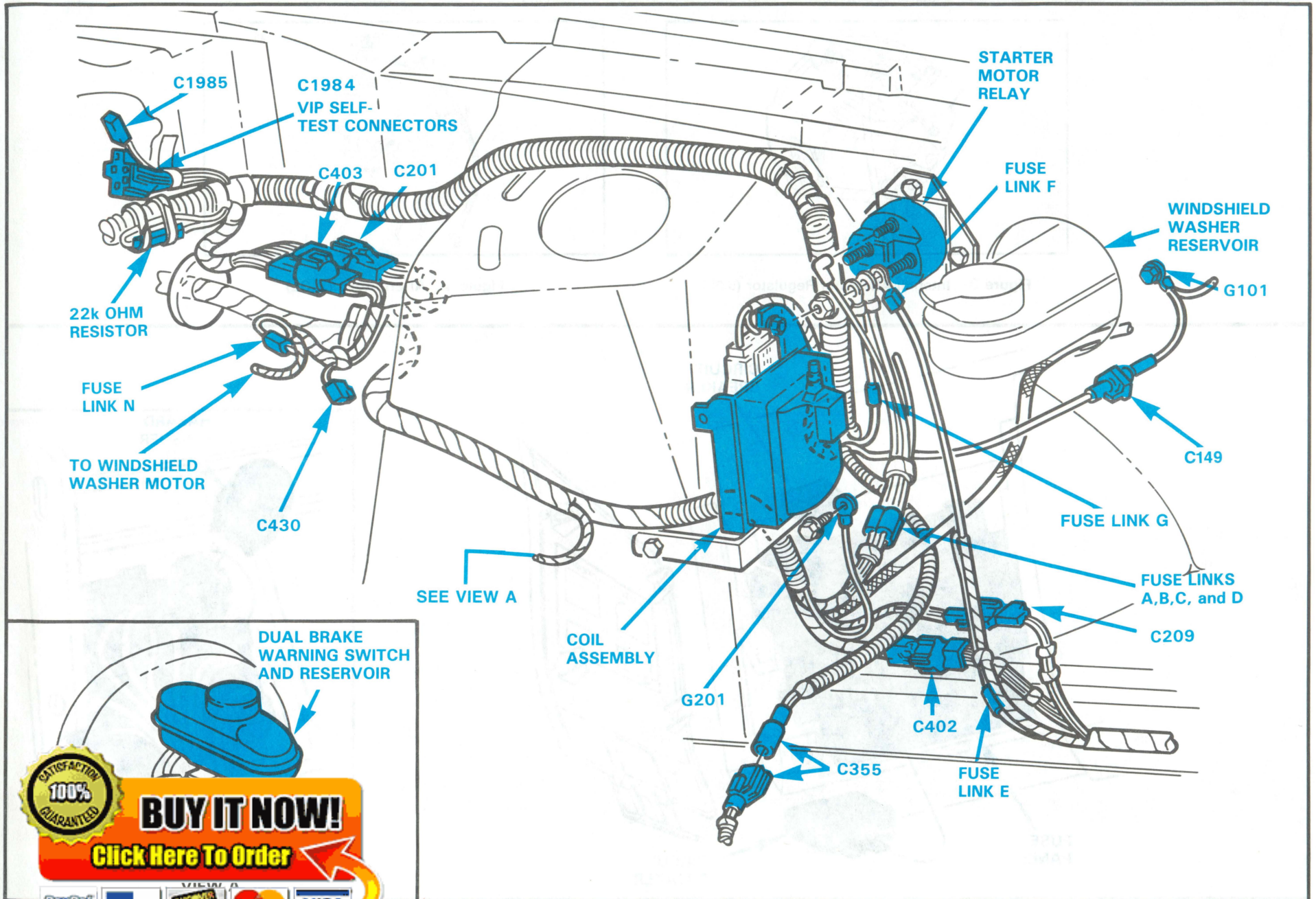

Figure 2- LH Fender Apron (5.0L)



BUY IT NOW!

[Click Here To Order](#)



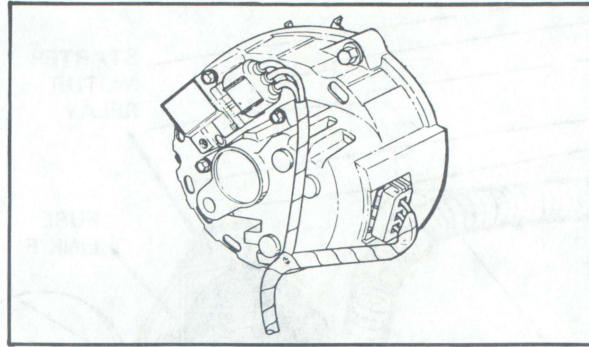

Figure 3- Integral Alternator/Regulator (5.0L)

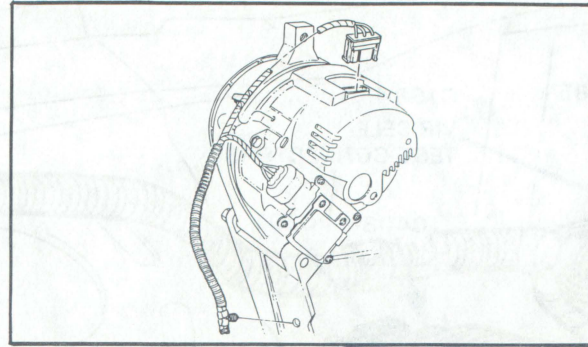

Figure 4- Alternator (2.3L)

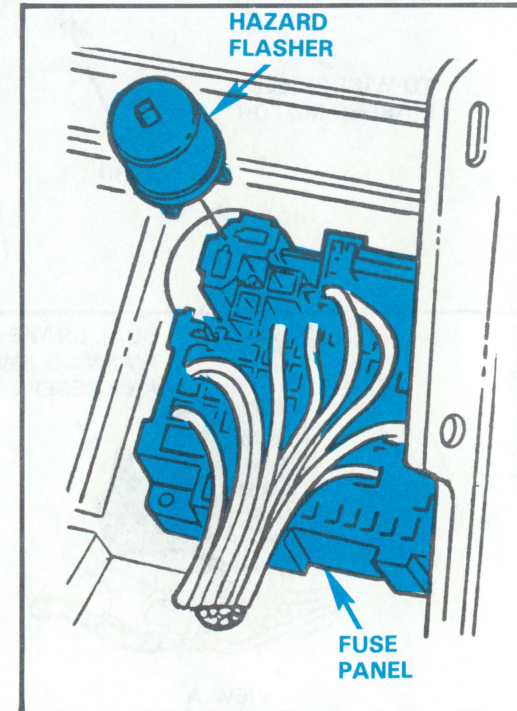
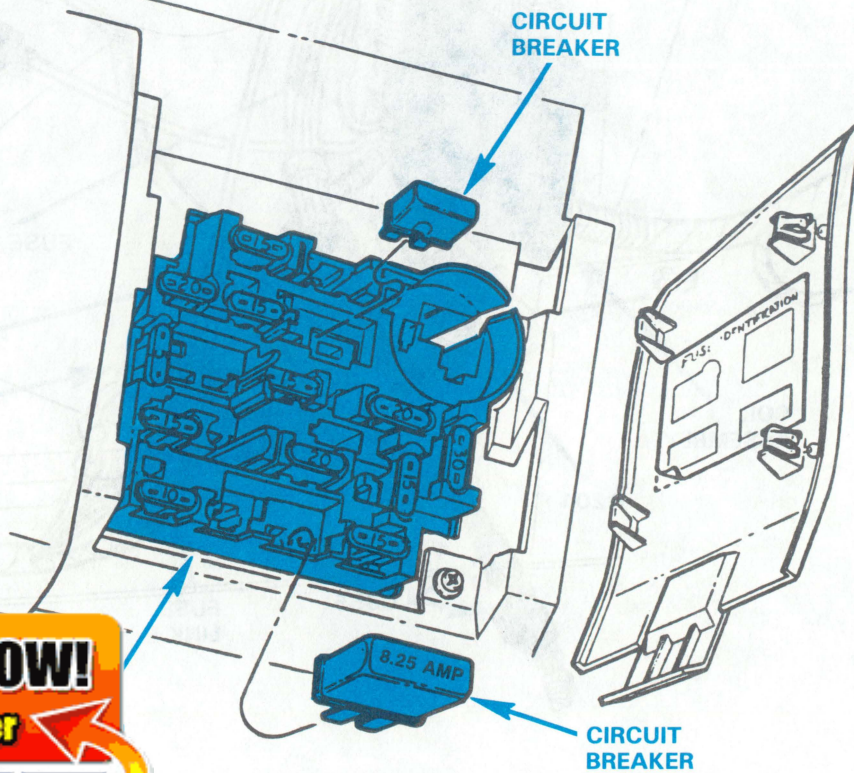

Figure 5- Circuit Breaker and Hazard Warning Flasher

100% SATISFACTION GUARANTEED

BUY IT NOW!

Click Here To Order

PayPal American Express Discover MasterCard VISA

124 COMPONENT TESTING: A/C HEATER FUNCTION CONTROL

Notes 3/18/11

TERMINAL LOCATIONS

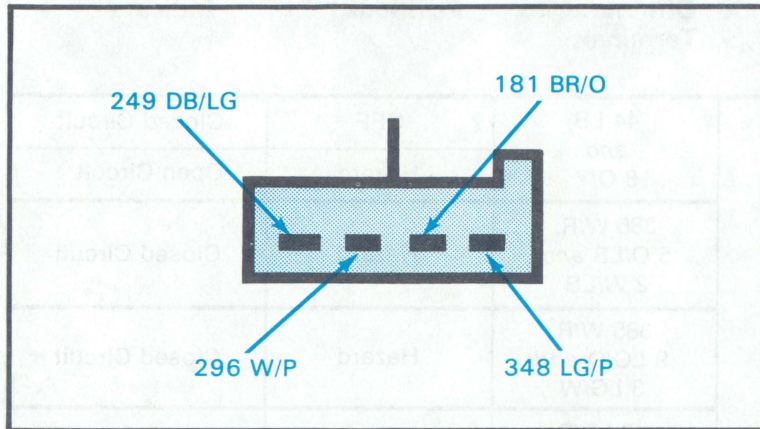

COMPONENT TESTING PROCEDURE

TO TEST	Connect Self Powered Test Lamp or Ohmmeter to Terminals	Move Switch to These Positions	A Good Switch Will Indicate
A/C Clutch Switch Circuit	296 W/P and 348 LG/P <i>Floor/Mix</i>	OFF A/C Max A/C Normal Vent Hi/Lo Heat Defrost	Open Circuit Closed Circuit Closed Circuit Open Circuit Open Circuit Open Circuit Open Circuit
Blower Motor Control Switch Circuit	181 BR/O and 249 DB/LG	OFF All other positions	Open Circuit Closed Circuit

SCHEMATIC

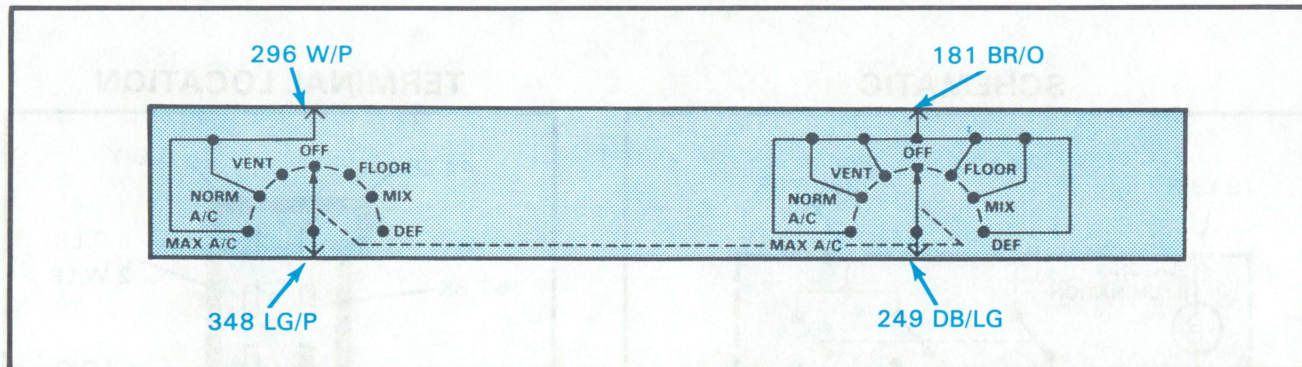

100% SATISFACTION GUARANTEED

BUY IT NOW!

Click Here To Order

TERMINAL LOCATION

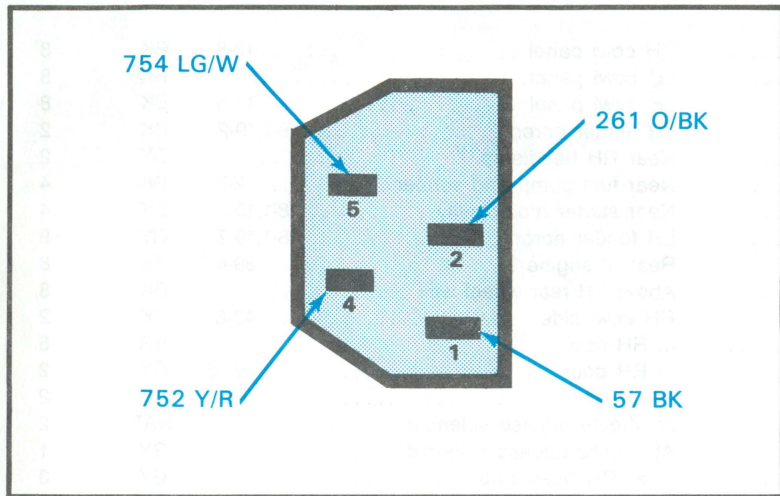

SCHEMATIC

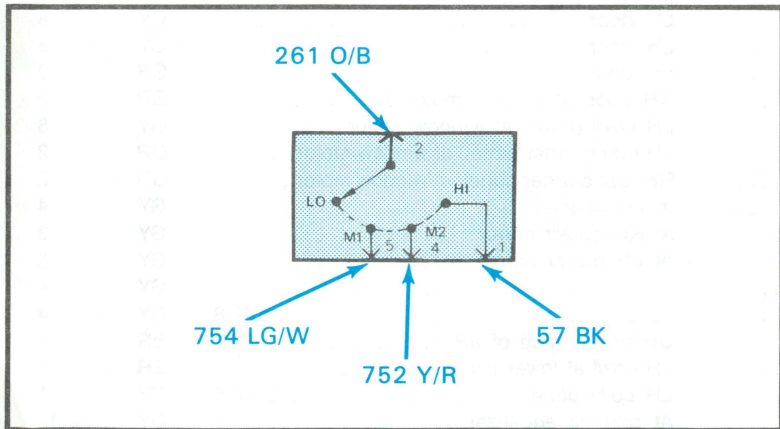

COMPONENT TESTING PROCEDURE

TO TEST	Connect Self Powered Test Lamp or Ohmmeter to Terminals	Move Control to These Positions	A Good Switch Will Indicate
Medium-Low Speed	261 O/BK (2) <i>and</i> 754 LG/W (5)	Lo Medium-1 Medium-2 Hi	Open Circuit Closed Circuit Open Circuit Open Circuit
Medium-High Speed	261 O/BK (2) <i>and</i> 752 Y/R (4)	Lo Medium-1 Medium-2 Hi	Open Circuit Open Circuit Closed Circuit Open Circuit
High Speed	261 O/BK (2) <i>and</i> 57 BK (1)	Lo Medium-1 Medium-2 Hi	Open Circuit Open Circuit Open Circuit Closed Circuit

NOTE

Blower Switch is designed to make contacts with two terminals at one time, except when in LO.

100% SATISFACTION GUARANTEED

BUY IT NOW!

Click Here To Order

Attach to page 125 of: Mustang EVTM - Refer to TSB 91-18B-21 for Revised Color, Pin Number Designation For C405/Revised Color For Terminal 261

CONNECTOR LOCATION

		Page- Figure	Color	Terminals
C106	Near LH headlamp		BK	2
C107	LH side of transmission	25-1,2	GY	4
C117	Behind RH side of I/P	117-1	BK	2
C135	RH cowl panel	42-8	BK	8
C149	Near battery	24-1	BK	1
C150	Rear of engine		BR	4
C166	Rear side of RH valve cover		BK	4
C190	At rear of engine	38-3	BK	10
C191	Rear of engine	38-3	GY	10
C197	At rear of engine	39-4	GY	8
C201	LH fender apron	18-1,19-2	GY	8
C205	At back of radio	117-1	BK	8
C205A	At back of radio		GY	8
C209	LH fender apron	18-1,19-2	BK	8
C211	Attached to hazard switch		GY	6
C212	Attached to multi-function switch	117-1	GY	4
C216	LH cowl panel	40-5	GY	8
C218	At stoplamp switch	117-1	BK	2
C219	Near T/O to G100	117-1	GY	2
C220	At speed control amplifier	106-1	GY	6
C228	Lower LH cowl panel	40-5	BK	12
C239	At RH front I/P speaker	97-3	GY	2
C240	At LH front I/P speaker	97-3	GY	2
C243	Behind I/P above LH side of glove box	117-1	BK	8
C246	RH rear of instrument panel	117-1	GY	14
C247	LH rear of instrument cluster	117-1	GY	14
C248	At wiper motor and switch		GY	3
C249	At wiper motor and switch		GY	3
C250	At premium sound amplifier	96-2	GY	8
C257	Connected to fuse panel		NAT	1
C258	Behind LH side of I/P attached to light switch	51-2	GY	6
C259	LH cowl panel	40-5	GY	3
C261	At premium sound amplifier	96-2	BK	8
C262	Attached to dimmer rheostat	117-1	BK	4
C265	At back of radio	96-1	BK	8
C265A	At amplifier		GY	8
C275	LH side of engine	38-3	BK	2
	On steering column near ignition switch	117-1	GY	4
	motor	93-1	BK	2
			GY	3
	ge compartment	67-7	GY	1
	ngage compartment	67-7	GY	3
	speaker	100-4	R	2
	speaker	100-4	R	2

CONNECTOR LOCATION

		Page- Figure	Color	Terminals
C314	RH cowl panel	42-8	BK	8
C315	LH cowl panel	40-5	BK	8
C350	LH cowl panel	40-5	BK	8
C355	LH fender apron	18-1,19-2	BK	2
C400	Near RH headlamp		GY	2
C401	Near fuel pump and sender	42-7	BK	4
C402	Near starter motor relay	18-1,19-2	BK	4
C403	LH fender apron	18-1,19-2	GY	8
C404	Rear of engine	39-4	BK	8
C405	Above LH rear wheel well		BK	8
C406	RH cowl side	42-8	BK	2
C407	In RH door		BR	6
C408	In RH door	100-5	GY	2
C409	In LH door	100-5	BR	2
C411	At liftgate release solenoid		NAT	2
C412	At decklid release solenoid		GY	1
C413	Near RH headlamp		GY	3
C415	LH door		GY	8
C416	RH door		BR	6
C417	LH cowl panel	40-5	BK	6
C418	LH cowl panel	40-5	BK	4
C419	LH door		GY	8
C420	LH door		GY	8
C422	LH door		GR	2
C423	RH door, at window motor		GR	2
C424	LH cowl panel, at window motor		GY	8
C425	LH rear quarter panel, at window motor		GR	2
C426	RH rear quarter panel, at window motor		GR	2
C427	In LH door		GY	4
C431	At RH power mirror		GY	3
C432	At LH power mirror		GY	3
C433			GY	4
C434		42-8	GY	4
C436	Under RH side of I/P	87-1	BR	1
C437	LH cowl at lower access hole		BR	1
C439	LH cowl panel	40-5	GY	1
C441	At graphic equalizer		GY	12
C442	Under right front seat			2
C443	Under front seat		BR	2
C444	Under front seat		GY	2
C445	Under front seat		GY	2
C446	Under front seat		BK	2
C447	Under front seat		BK	2
C448	Under front seat		BR	2
C450	RH rear of engine (2.3L)	39-4	BK	4
C451	LH rear of engine (5.0L)	41-6	BK	4

100% GUARANTEED

BUY IT NOW!

Click Here To Order

PayPal American Express Discover MasterCard VISA

CONNECTOR LOCATION

		Page- Figure	Color	Terminals
C452	RH rear of engine (5.0L)	41-6	BK	4
C453	LH quarter panel	86-3	BK	2
C1984	LH fender apron		GY	6
C1985	LH fender apron		GY	1

SPLICE LOCATION

S105	Near T/O to headlamp switch
S117	Near to rear window defrost relay
S118	Near LH cowl side
S119	Near T/O to instrument cluster
S127	On lower RH cowl
S130	Near T/O to EGR solenoid
S131	Near connector to battery ground terminal
S132	Near T/O to EEC power relay
S135	Near T/O to No. 1 and 4 injectors
S136	Near T/O to No. 2 and 3 injectors
S137	Near injectors (2.3L)
S138	Near throttle air bypass valve solenoid
S140	Near ECA T/O
S141	Near C150 T/O
S142	Near C150 T/O
S144	Near T/O to TFI module
S147	Near connector to battery (2.3L)
S148	In engine compartment, near battery
S151	Near engine coolant temperature sensor
S152	On lower RH cowl
S153	Near injectors (5.0L)
S160	Rear side of RH valve cover
S161	Near T/O to HEGO sensors
S190	Near fuse panel T/O
S201	Near graphic equalizer T/O
S207	Near T/O to C259
S214	Near T/O to RH I/P courtesy lamp
S218	Near C405 T/O
S302	Near T/O to G201
S303	Near windshield wiper T/O
S303	Near T/O to windshield wiper
S304	Near T/O to RH door lock motor
S304	
S306	
S335	
S401	
S404	
S408	

SPLICE LOCATION

S505	Near T/O to G301
S506	LH corner of liftgate near LH park and stop lamp
S511	Near T/O to G303
S512	Near T/O to A/C heater blower switch
S550	Near LH front window control switch T/O
S600	Near T/O to C259
S601	Near T/O to G313
S602	In LH door near grommet
S603	Near T/O to RH rear power window switch
S605	Near T/O to rear window defrost relay
S802	Near T/O to G103
S806	Near T/O to G103
S1004	Near T/O to G303
S2000	Near A/C clutch field coil
S2002	Near idle speed actuator
S2003	Near pin 21 — ECA
S2004	Near to T/O to connector C247
S2205	Near ignition switch
S2007	Near 22K resistor, off EEC module
S2008	Near T/O to steering column
S2009	Near T/O to wiper motor
S2010	Near T/O to convertible top relays
S2011	Near T/O to interval wiper governor
S2013	Near T/O to LH license lamp
S2014	Near fuse panel
S2015	Near rear of radio
S2017	Near visor vanity mirrors
S2050	Near T/O to RH headlamp

GROUND LOCATION

		Page- Figure
G100	A/C ground	
G101	Engine ground	24-1
G102	Top RH side of radiator support above headlamp	
G103	Top LH side of radiator support above headlamp	
G116	Body ground	
G118	At electronic control assembly	
G119	Near T/O to RH headlamp	
G122	Engine ground, RH fender apron, near battery	
G150	On lower RH cowl	38-3
G201	LH fender apron	
G202	LH fender apron	
G301	Near LH backup lamp	66-6

100% SATISFACTION GUARANTEED

BUY IT NOW!

Click Here To Order



GROUND LOCATION

		Page- Figure
G303	LH corner of liftgate	88-2
G304	LH corner of liftgate	89-3
G305	In console near parking brake lever	
G307	(2 Dr) attached to RH package tray support	
G307	(3 Dr) RH side of liftgate below window	88-2
G309	Near T/O to dome lamp	65-4
G313	On LH door	73-1
G315	Near convertible top motor	93-1
G320	On LH I/P shake brace	
G321	On LH door	73-1
G326	Near T/O to dome lamp	65-5
G330	On instrument panel shake brace	117-1
G331	On instrument panel shake brace	
G340	Under front seat	
G500	Near park brake signal lamp switch	
G601	Right rear of engine	



BUY IT NOW!

Click Here To Order 





We Want To Hear From You!

Do you have any suggestions for improving this publication?

FOR EXAMPLE . . .

- Did you find any errors?

If yes; Manual _____ Page _____

- Were any subjects not covered?

If yes; Please describe. _____

- Were any sections confusing or hard to understand?

If yes; Manual _____ Page _____

Please comment: _____

- Could you quickly find what you need? Yes _____ No _____

Suggestion: _____

- Tell us who you are:

Name _____

Address _____

Position _____ Company _____

It would be most helpful if you could enclose a copy of each page, marked with your suggestions.



BUY IT NOW!

Click Here To Order



DO NOT STAPLE — USE TRANSPARENT TAPE

NO POSTAGE
NECESSARY
IF MAILED
IN THE
UNITED STATES

BUSINESS REPLY MAIL
FIRST CLASS PERMIT NO. 400 DEARBORN, MICH.

POSTAGE WILL BE PAID BY ADDRESSEE

Ford Parts and Service Division
Advanced Service Engineering
Fairlane Technical Center
P.O. Box 1902
Dearborn, Michigan 48121



BUY IT NOW!
Click Here To Order





**WE SUPPORT VOLUNTARY
TECHNICIAN CERTIFICATION**



**Ford Parts and Service Division
Training and Publications Department**

100% SATISFACTION GUARANTEED

BUY IT NOW!

Click Here To Order 

PayPal   

AUG. 1987



FPS-12121-88