

1988 BRONCO/ F150-F350/ -SUPER DUTY



DEMO

This DEMO contains only a few pages of the entire manual/product.

Not all Bookmarks work on the Demo, but they do on the full version.

Features:

- Searchable text
- Printable pages
- Bookmarked for easy navigation
- High Resolution images
- Zoom to see exact details
- Money back Guarantee
- Available on USB and eBook download

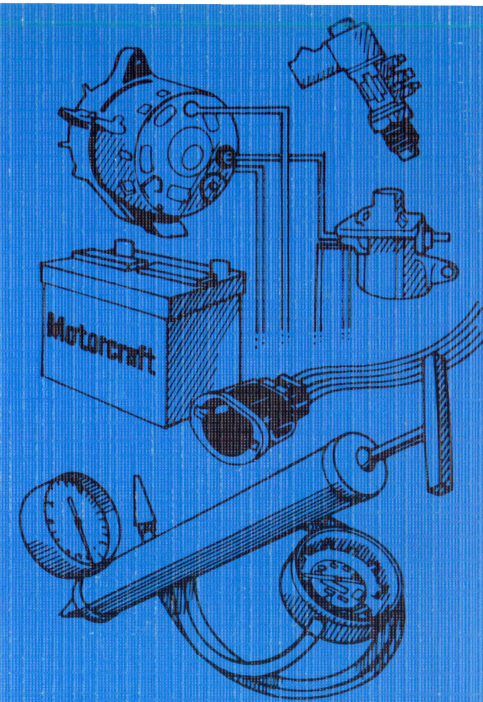

Electrical & Vacuum Trouble- Shooting Manual

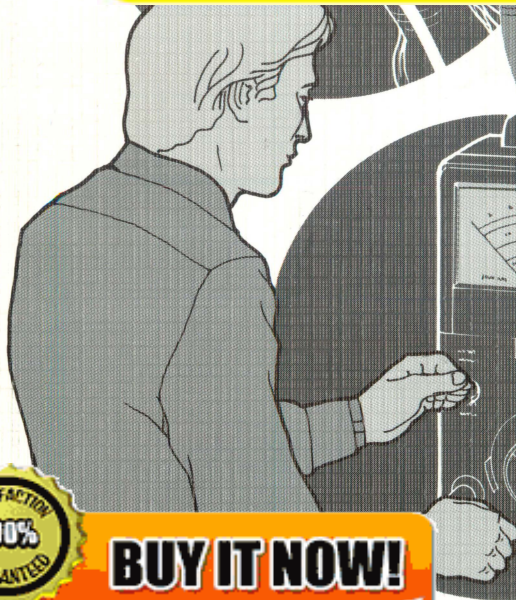
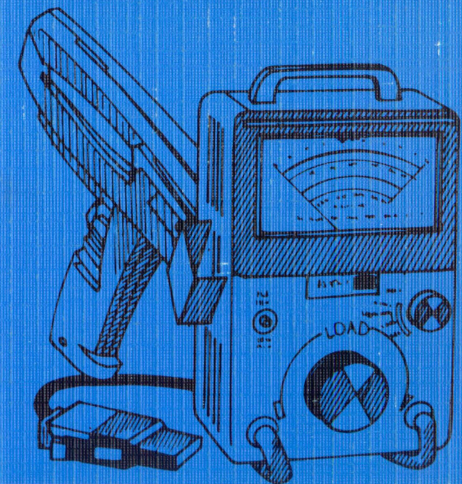

100% SATISFACTION GUARANTEED

BUY IT NOW!

Click Here To Order

PayPal American Express Discover MasterCard VISA



License #84356800

Copyright © 2023, Forel Publishing Company, LLC, Woodbridge, Virginia

All Rights Reserved. No part of this book may be used or reproduced in any manner whatsoever without written permission of Forel Publishing Company, LLC. For information write to Forel Publishing Company, LLC, Woodbridge, VA 22192

**1988 Bronco/F150-F350/ F-Super Duty Electrical &
Vacuum Trouble-Shooting Manual (EVTM)**

EAN: 978-1-60371-411-2

ISBN: 1-60371-411-1

Forel Publishing Company, LLC
Woodbridge, VA 22192
Email: sales@ForelPublishing.com
<https://www.ForelPublishing.com>



This publication contains material that is reproduced and distributed under a license from Ford Motor Company. No further reproduction or distribution of the Ford Motor Company material is allowed without the express written permission of Ford Motor Company.

Note from the Publisher

This product was created from the original Ford Motor Company's publication. Every effort has been made to use the original scanned images, however, due to the condition of the material; some pages have been modified to remove imperfections.

Disclaimer

Although every effort was made to ensure the accuracy of this book, no representations or warranties of any kind are made concerning the accuracy, completeness or suitability of the information, either expressed or implied. As a result, the information contained within this book should be used as general information only. The author and Forel Publishing Company, LLC shall have neither liability nor responsibility to any person or entity with respect to any loss or damage caused, or alleged to be caused, directly or indirectly by the information contained in this book. Further, the publisher and author are not engaged in rendering legal or other professional services. If legal, mechanical, electrical, or other expert assistance is required, the professional should be sought.



ELECTRICAL AND VACUUM TROUBLESHOOTING MANUAL

FPS — 12129 - 88

ORDER INFORMATION

Information on how to order additional copies of this publication or other Ford publications, may be obtained by writing to Helm Incorporated at the address shown below. Other publications available include:

- Shop Manuals
- Service Specification Books
- Car/Truck Wiring Diagram Books
- Engine/Emissions Diagnosis Manuals

Helm Incorporated
P.O. Box 07150
Detroit, Michigan 48207



TABLE OF CONTENTS

How to Use This Manual	1
How to Find the Electrical Problem	2,3
Symbols (Electrical)	4
(Vacuum)	110
How to Find the Vacuum Problem	112
Component Testing	
Introduction	123
Main Light Switch	123
Hazard Switch	125
Ignition Switch	124
Turn Signal Switch	125
Windshield Wiper/Washer Switch	126
Interval Wiper/Washer Switch	127
A/C-Heater Function Selector	128
A/C-Heater Blower Switch	129
Location Index	130

INDEX

A/C-Heater	117
Anti-Lock Brakes	75
Brake Warning Indicator	69
Charge (Gasoline)	15
(Diesel)	20
Cigar Lighter	88
Coolant Temperature Gage	82
Diesel Glow Plug Control	30
Electric Fuel Pump Control	86
Electronic Engine Control	35
Electronic Shift—4 Wheel Drive	77
Four-Wheel Drive Indicator	78
Fuel Injector Cooling Fan—(4.9L Only)	46
Fuel Tank Selector/Gages (Diesel)	83
(Gasoline)	81
Fuse Panel (Diesel)	22
(Gasoline)	17

Gages (Diesel)	83
(Gasoline)	81
Grounds	5
Heater	116
Horn	88
Ignition	25
Instrument Illumination	67
Lamps On Warning	63
Lamps	
Backup	61
Body Marker	52
Cargo	61
Dome	63
Exterior	50
Hazard	57
Headlamps	48
Instrument Illumination	67
License	51
Map	63
Marker	51
Park	51
Radio Illumination	67
Stop	57
Tail (Rear Park)	50
Trailer	52
Turn	57
Main Light Switch	67
Power Distribution (Diesel)	20
(Gasoline)	15
Power Door Locks	103
Power Windows	96
Radio (Stereo) (Electronic)	106
Rear Window Defrost	99
Seatbelt Warning	69
Speed Control	113
Start (Diesel)	30
(Gasoline)	25

Tachometer	82
Tailgate Power Window	99
Trailer	103
Vacuum Distribution	111
Warning Indicators (Diesel)	72
(Gasoline)	69
Windshield Wiper/Washer	91
Windshield Wiper/Washer (Interval)	93

IMPORTANT SAFETY NOTICE

Appropriate service methods and proper repair procedures are essential for the safe, reliable operation of all motor vehicles, as well as the personal safety of the individual doing the work. This Manual provides general directions for accomplishing service and repair work with tested, effective techniques. Following them will help assure reliability.

There are numerous variations in procedures, techniques, tools, and parts for servicing vehicles, as well as in the skill of the individual doing the work. This Manual cannot possibly anticipate all such variations and provide advice or cautions as to each. Accordingly, anyone who departs from the instructions provided in this Manual must first establish that he compromises neither his personal safety nor the vehicle integrity by his choice of methods, tools or parts.



BUY IT NOW!

Click Here To Order



contains hyperlinks pages

This manual contains the following diagnostic information:

- Electrical and Vacuum Schematics
- Component Location Indexes and Views
- Troubleshooting Hints
- Descriptions of Circuit Operation
- Component Testing

The vehicle's entire electrical system is broken down into individual systems. There are also sections for the vehicle's ground and power distribution circuitry. Each system section begins with a wiring schematic. The **Schematics** should always be your starting point in using this manual. These schematics show the paths of electrical current during proper circuit operation. The source of voltage (circuit breaker or fuse) is shown at the top of the page. All wire, connectors, splices, switches, and motors are shown in the flow of current to ground at the bottom of the page. Connector end views of switches and other components are shown to help with bench testing. Each circuit component is named (underlined titles). Wire and connector colors are listed (standard Ford color abbreviations are used). These abbreviations are:

COLOR ABBREVIATIONS

BL	Blue	N	Natural
BK	Black	O	Orange
BR	Brown	PK	Pink
DB	Dark Blue	R	Red
DG	Dark Green	P	Purple
GR	Green	T	Tan
GY	Gray	W	White
LB	Light Blue	Y	Yellow
	Light Green		

The **Component Location** section of each system helps you locate the circuit's components in the vehicle. A brief statement of the location is given as well as a reference to an illustrative figure in the manual. There is also a full listing of connector, ground, and splice locations in the **Location Index** in the back of the manual.

OTHER ABBREVIATIONS

T/O (Tape Out) The point at which a harness branches to feed a component.

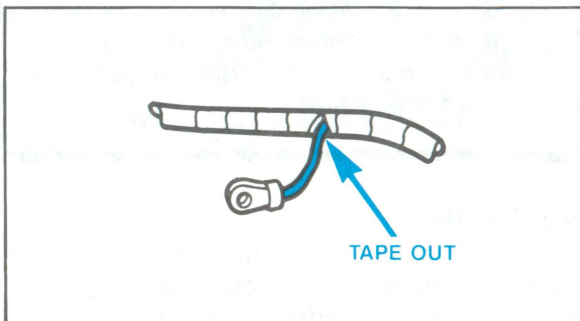

The **Troubleshooting Hints** offer shortcuts or tests that help you determine the cause of an electrical problem. They are not intended to be a rigid procedure for solving an electrical situation. Rather, Troubleshooting Hints represent a common-sense approach that is based on an understanding of the circuit.

A description of **How the Circuit Works** is written to help you understand the operation of the circuit as a whole. Emphasis is placed on how the components and circuitry interact in a properly working system.

A **Component Testing** section provides procedures to determine whether a component is good or bad.

Notes, Cautions, and Warnings appear in boxes on text pages and contain important vehicle and mechanic **safety** information.

Notes give added information to help complete a particular procedure. Cautions are included to prevent making an error that could damage the vehicle. Warnings highlight areas where carelessness can cause personal injury. The following list contains some general **Warnings** that should be followed when working on a vehicle.

- Always wear safety glasses for eye protection.
- Use safety stands whenever a procedure requires being under a vehicle.
- Be sure that the **Ignition Switch** is always in the OFF position, unless otherwise required by the procedure.
- Set the parking brake when working on any vehicle. An automatic transmission should be in PARK. A manual transmission should be in NEUTRAL.
- Operate the engine only in a well-ventilated area to avoid the danger of carbon monoxide.
- Keep away from moving parts when the engine is running, especially the fan and belts.
- To prevent serious burns, avoid contact with hot metal parts such as the radiator, exhaust manifold, tail pipe, catalytic converter, and muffler.
- Do not allow flame or sparks near the battery. Gases are always present in and around the battery cell. An explosion could occur.
- Do not smoke.
- To avoid injury, always remove rings, watches, loose hanging jewelry, and loose clothing.

... wire, the
... The sec-

100% SATISFACTION GUARANTEED

BUY IT NOW!

Click Here To Order

PayPal American Express Discover MasterCard VISA

TROUBLESHOOTING STEPS

These six steps present an orderly method of troubleshooting:

Step 1. Verify the problem.

- Operate the complete system and see all symptoms for yourself in order to:
 - check the accuracy and completeness of the customer's complaint.
 - learn more that might give a clue to the nature and location of the problem.

Step 2. Narrow the problem.

- Using this manual, narrow down the possible causes and locations of the problem in order to more quickly find the exact cause.
- Read the description of *How the Circuit Works* and study the wiring diagram. You should then know enough about the circuit operation to figure out where to check for this trouble.

Step 3. Test the cause.

- Use electrical test procedures to find the specific cause of the symptoms.
- *Troubleshooting Hints* will give some helpful ideas.
- The *Component Location* charts and the pictures will help you find components, grounds, and connectors.

Step 4. Verify the cause.

- Confirm the fact that you have found the correct cause through operating the parts of the circuit you think are good.

Step 5. Make the repair.

- Repair or replace the faulty component.

Step 6. Verify the repair.

Step 1 and check all symptoms. If any new special test s. See the

Shop Manual and other service books for details. You will find the circuits in this manual to be helpful with these special tests.

TROUBLESHOOTING TOOLS

JUMPER WIRE

This is a test lead used to connect two points of a circuit. A **Jumper Wire** can complete a circuit by bypassing an open.

Uses: Bypassing Switches or Open Circuits

WARNING

Never use a jumper wire across loads (motors, etc.) connected between hot and ground. This direct battery short may cause injury or fire.

VOLTMETER

A DC **Voltmeter** measures circuit voltage. Connect negative (- or black) lead to ground, and positive (+ or red) lead to voltage measuring point.

OHMMETER

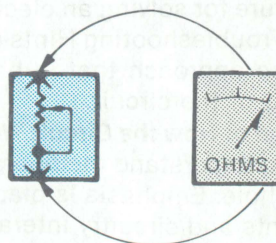

Figure 1— Resistance Check

An **Ohmmeter** shows the resistance between two connected points (Figure 1).

TEST LIGHT

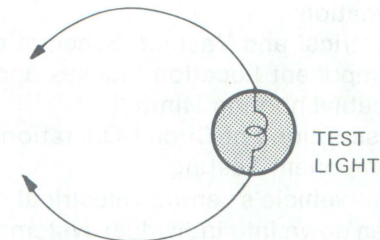

Figure 2 – Test Light

A **Test Light** is a 12-volt bulb with two test leads (Figure 2).

Uses: Voltage Check. Short Check

SELF-POWERED TEST LIGHT

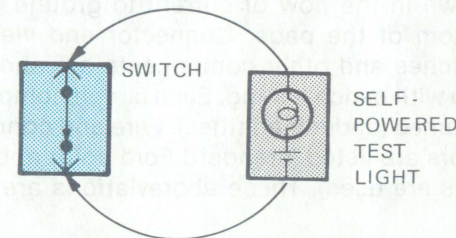

Figure 3—Continuity Check

The **Self-Powered Test Light** is a bulb, battery and set of test leads wired in series (Figure 3). When connected to two points of a continuous circuit, the bulb glows.

Uses: Continuity Check. Ground Check

CAUTION

When using a self-powered test light or ohmmeter, be sure power is off in circuit during testing. Hot circuits can cause equipment damage and false readings.

100% SATISFACTION GUARANTEED

BUY IT NOW!

Click Here To Order

TROUBLESHOOTING CHECKS

SWITCH CIRCUIT CHECK

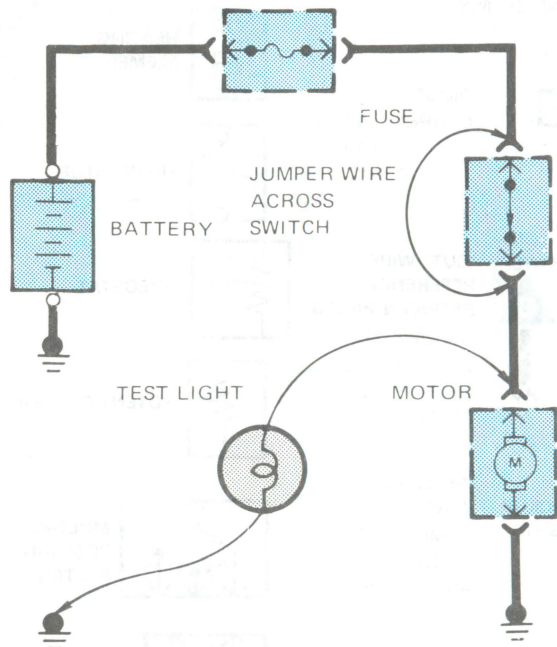

Figure 4—Switch Circuit Check and Voltage Check

In a bad circuit with a switch in series with the load, jumper the terminals of the switch to power the load. If jumping the terminals powers the circuit, the switch is bad (Figure 4).

CONTINUITY CHECK (Locating open circuits)

With power off, connect one lead of **Self-Powered Test Light** or **Ohmmeter** to each end of circuit (Figure 3). Light will glow if circuit is closed. Switches and fuses can be checked in the same way.

SHORT CHECK (short to ground)

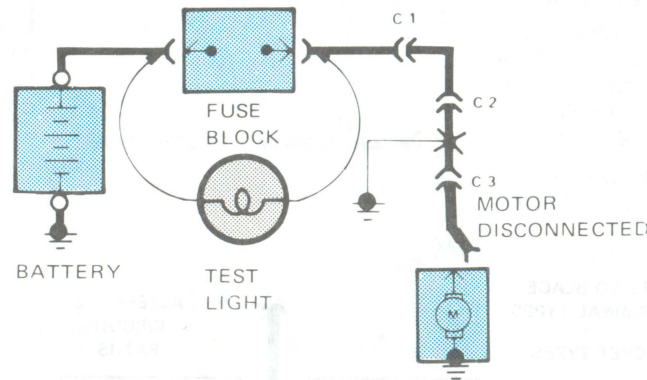

Figure 5—Short Check

A fuse that repeatedly blows is usually caused by a short to ground. It's important to be able to locate such a short quickly (Figure 5).

- 1) Turn off everything powered through the fuse.
- 2) Disconnect other loads powered through the fuse:
 - Motors: disconnect motor connector.
 - Lights: remove bulbs.
- 3) Turn **Ignition Switch** to RUN (if necessary) to power fuse.
- 4) Connect one **Test Light** lead to hot end of blown fuse. Connect other lead to ground. Bulb should glow showing power to fuse. *(This step is just a check to be sure you have power to the circuit.)*
- 5) Disconnect the **Test Light** lead from ground and reconnect it to the load side of the fuse.
 - If the **Test Light** is off, the short is in the disconnected equipment.
 - If the **Test Light** goes on, the short is in the wiring. You must find the short by disconnecting the circuit connectors one at a time until the **Test Light** goes out. For example: with a ground at X, the bulb goes out when C1 or C2 is disconnected, but stays on after disconnecting C3. This

means the ground is between C2 and C3.

"GOOD GROUND" CHECK

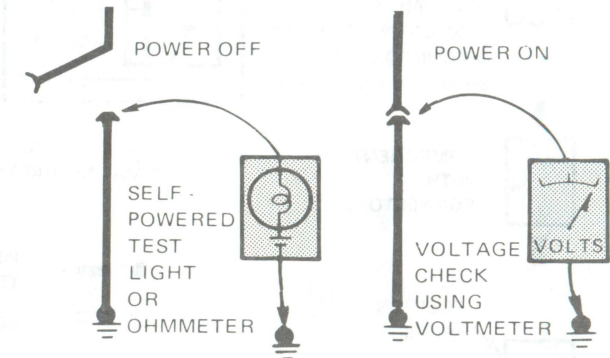

Figure 6 — Grounds Checks

Turn on power to circuit. Perform Voltage Check between suspected bad ground and frame. Any voltage means ground is bad.

Turn off power to circuit. Connect one lead of **Self-Powered Test Light** or **Ohmmeter** to wire in question, and the other to known ground. If bulb glows, circuit ground is OK (Figure 6).

TROUBLESHOOTING HINTS

The circuit schematics in this manual are designed to make it easy to identify common points in circuits. This knowledge can help narrow the problem to a specific area. For example, if several circuits fail at the same time, check for a common power or ground connection. (See *Power Distribution* or *Grounds*). If part of a circuit fails, check the connections between the part that works and the part that doesn't work.

For example, if low beam headlights work but high beams and the indicator light don't work, then power and ground paths must be good. Since the dimmer switch is the component which switches this power to the high beam lights and indicator, it is most likely the cause of failure.

100% SATISFACTION GUARANTEED

BUY IT NOW!

Click Here To Order

PayPal, American Express, Discover, MasterCard, VISA

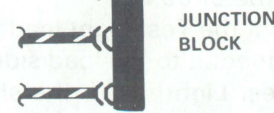
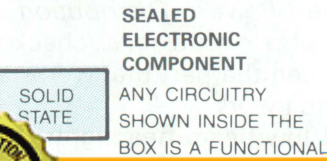
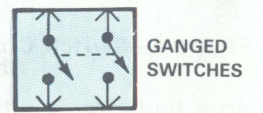
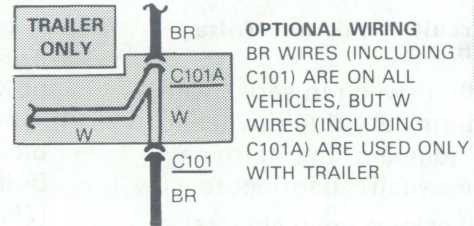
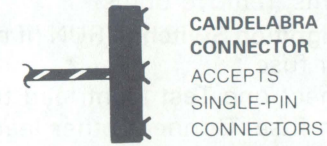
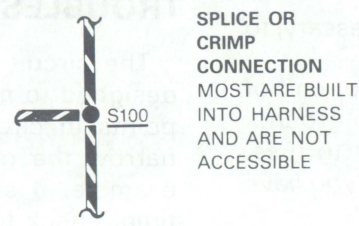
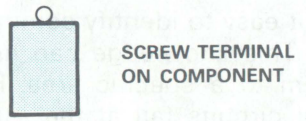
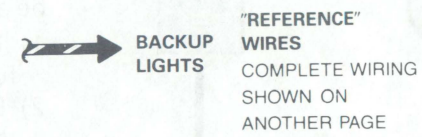
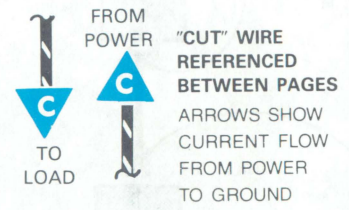
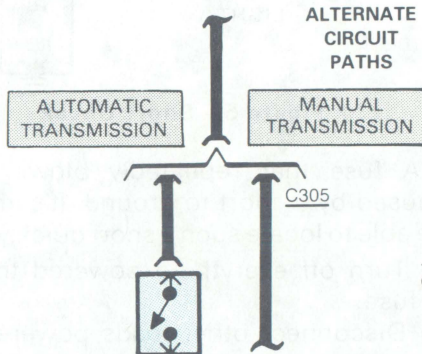
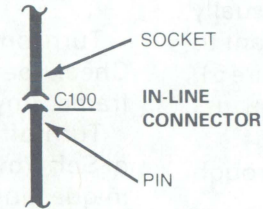
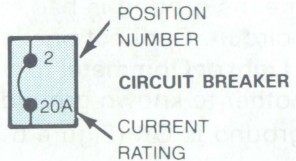
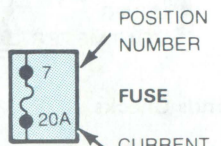
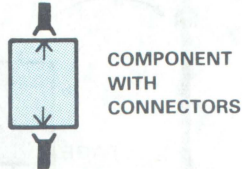
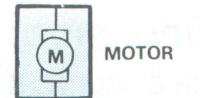
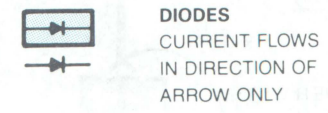
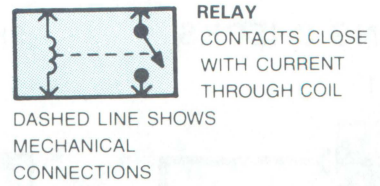
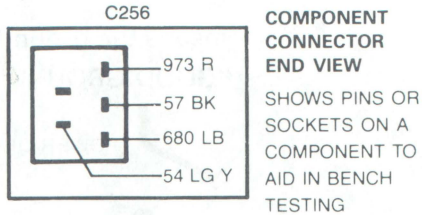
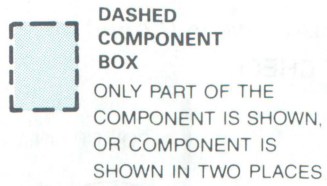

SEE GROUNDS PAGE 5-15

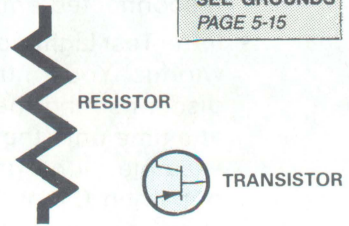
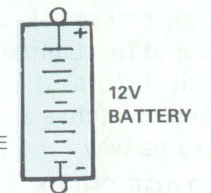
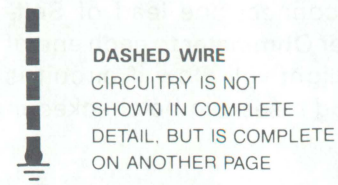

100% SATISFACTION GUARANTEED

BUY IT NOW!

Click Here To Order

PayPal, American Express, Discover, MasterCard, VISA

INSTRUMENT PANEL GROUND

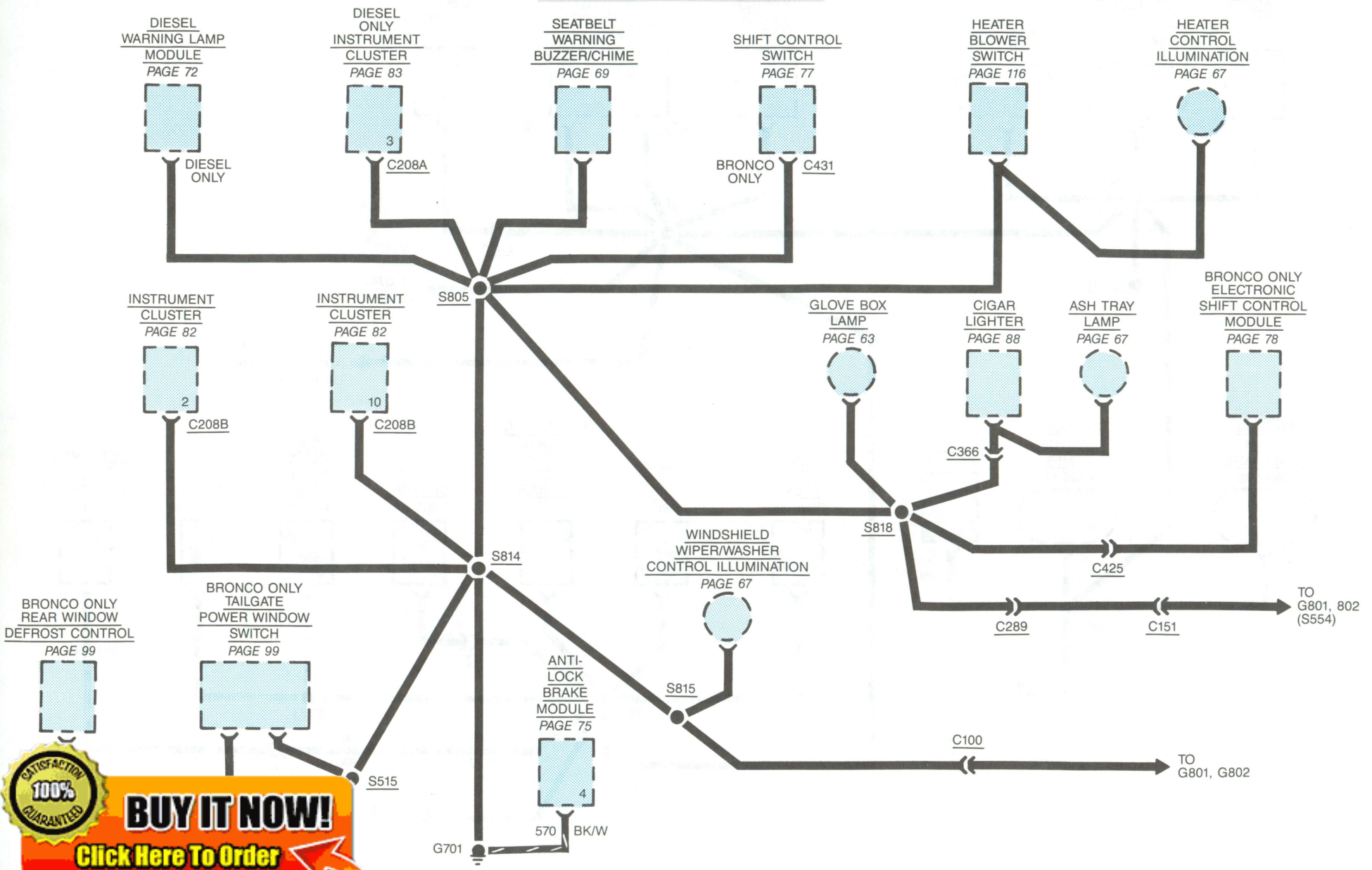

100% SATISFACTION GUARANTEED

BUY IT NOW!

Click Here To Order

PayPal, American Express, Discover, MasterCard, VISA

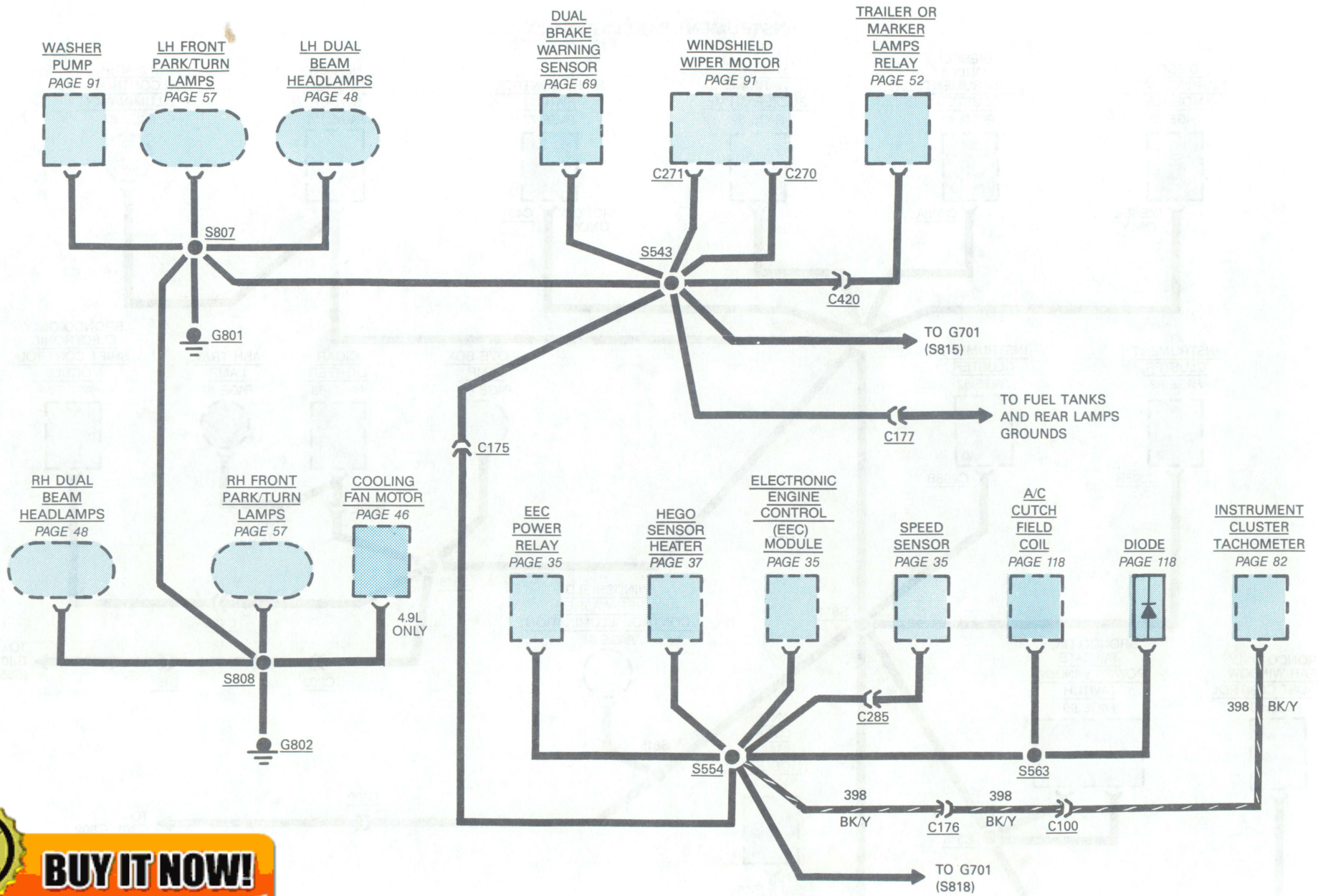

100% SATISFACTION GUARANTEED

BUY IT NOW!

Click Here To Order

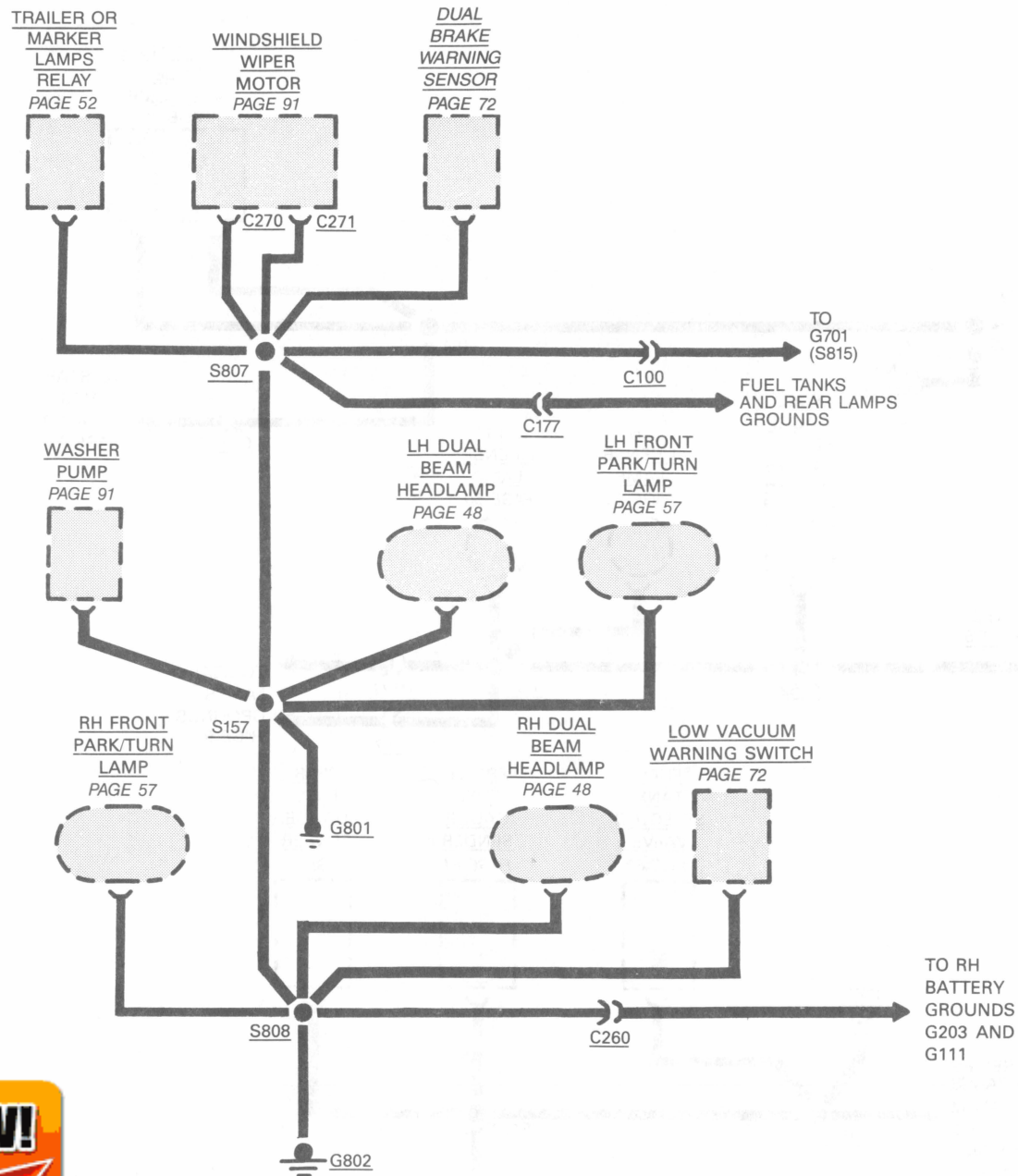

100% SATISFACTION GUARANTEED

BUY IT NOW!

Click Here To Order

8 GROUNDS (FUEL TANKS AND REAR LAMPS)

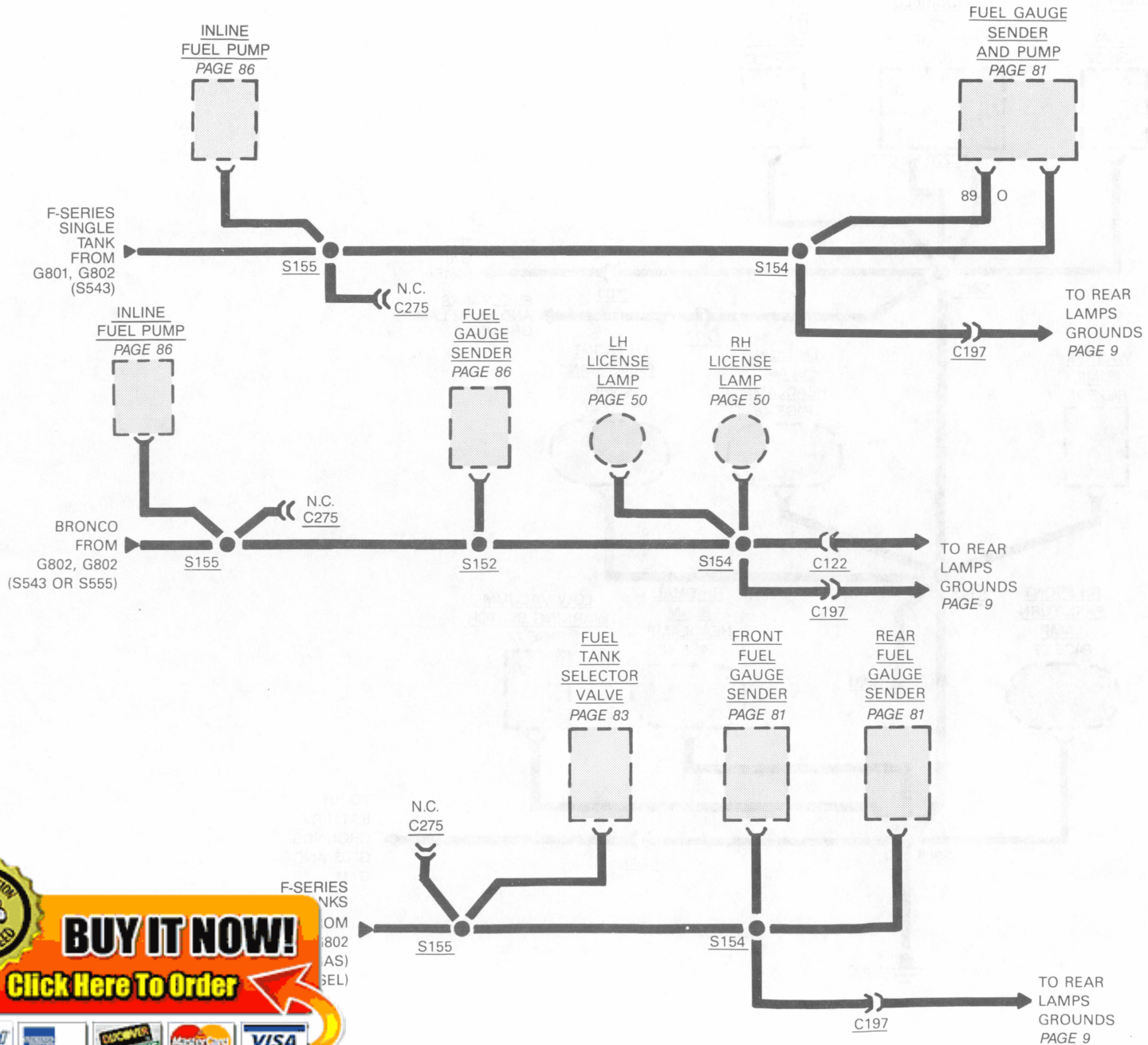

100% SATISFACTION GUARANTEED

BUY IT NOW!

Click Here To Order

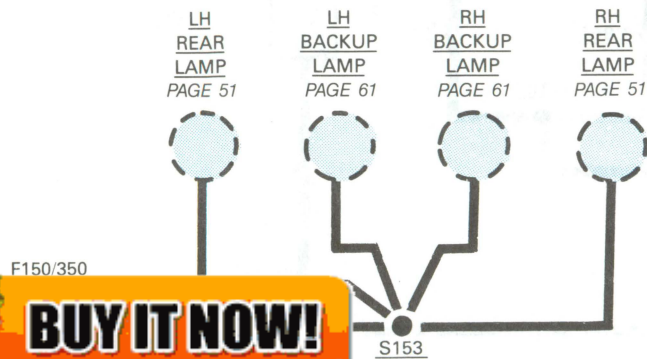
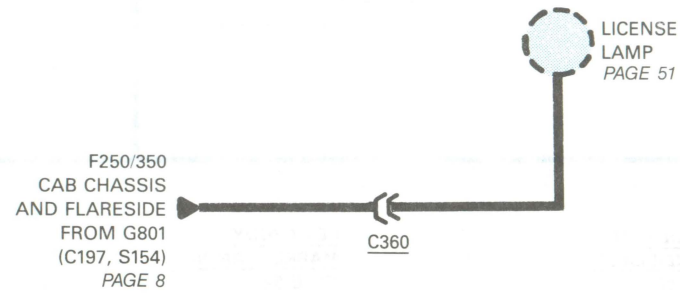
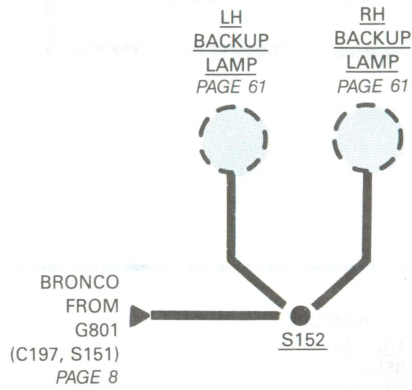
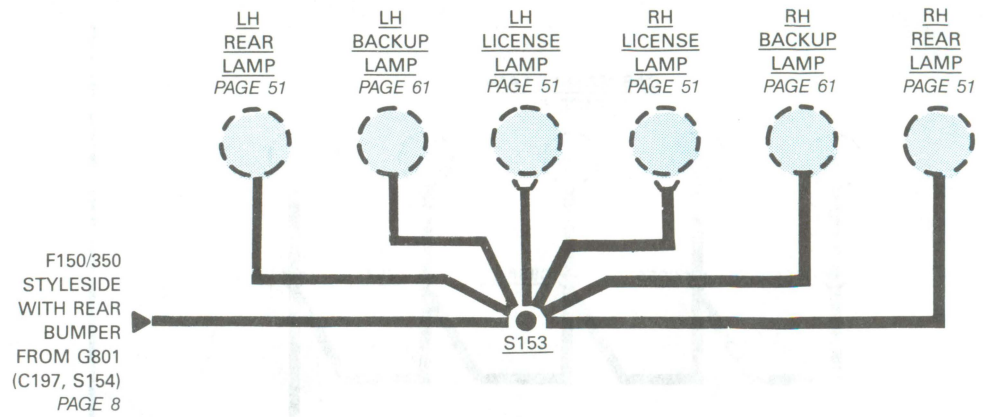
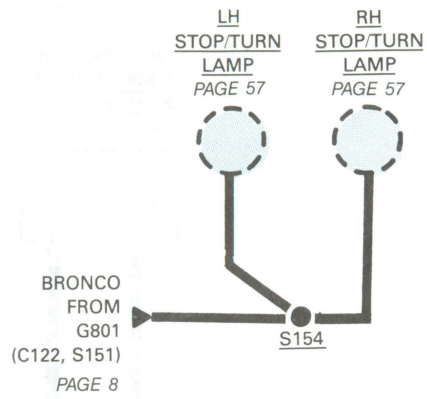

100% SATISFACTION GUARANTEED

BUY IT NOW!

Click Here To Order

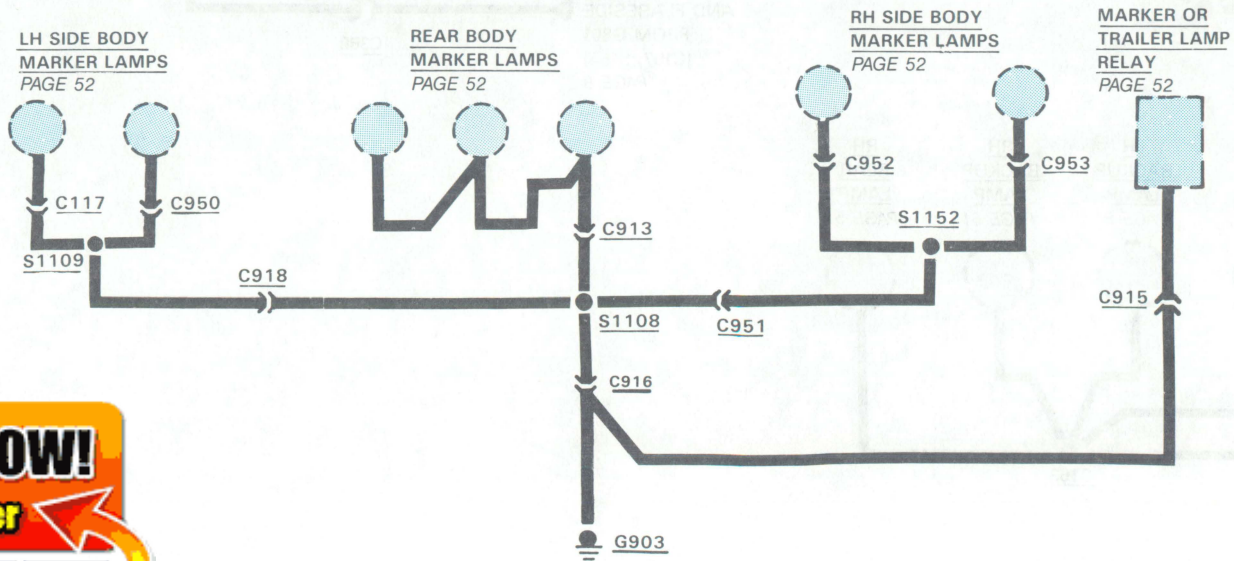
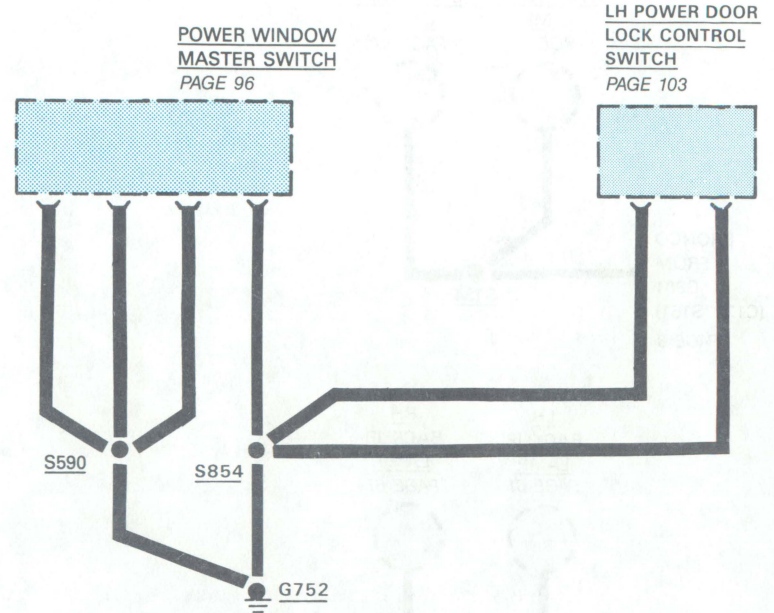
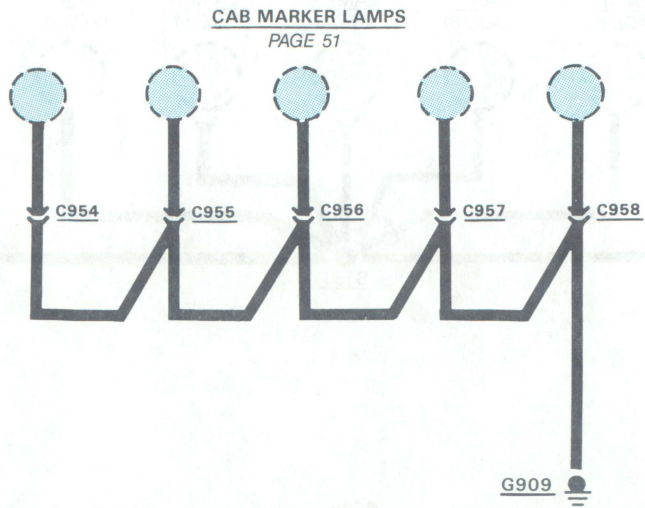

100% SATISFACTION GUARANTEED

BUY IT NOW!

Click Here To Order

PayPal American Express Discover MasterCard VISA

HOW THE CIRCUIT WORKS

The ground circuits shown here are complete and connect several components together to screw terminal ground points. On other pages only parts of these circuits may be shown. Partial ground circuits are shown dashed on those pages.

All simple or component ground circuits are shown on the individual circuit pages and are complete on those pages.

All ground wires are **57 BK** unless otherwise noted.

COMPONENT LOCATION

Page-
Figure

A/C Clutch Field Coil	Part of compressor	
Anti-Lock Brake Module	Behind I/P left of center	
Brake Sensor	Part of master cylinder	
Cooling Fan Motor	RH fender apron	
Diesel/Warning Lamp Module	Behind LH side of I/P near fuse panel	
Electronic Engine Control (EEC) Module	Behind LH kick panel	
EEC Power Relay	Under plastic shield at the air cleaner support bracket	
Electronic Brake Proport- ioning Valve	Inside of LH frame rail behind #1 cross- member	
Electronic Shift Control Module	RH cowl panel	
Fuel Tank Selector Valve	On LH side frame member behind cab	85-1
Heater Blower Switch	At center of I/P	
HEGO Sensor	In communicator tube connecting both exhaust pipes	29-3,122-2
Inline Fuel Pump	Inboard side of LH frame rail	
Low Vacuum Warning Switch	7.3L RH fender apron	
Power Window Master Switch	In LH door	
Rear Defrost Control	Under LH corner of I/P	
Seatbelt Warning Buzzer/Chime	Attached to rear RH side of I/P	101-2
Shift Control Switch	On LH side of I/P	
Speed Sensor	At transmission	
Tailgate Power Window Motor	In center of tailgate	102-3
Washer Pump	In washer reservoir	
Windshield Wiper Motor	Attached to center of dash panel	

Refer to the **Location Index** in the back of the manual for connector, ground, and splice descriptions and locations.

100% SATISFACTION GUARANTEED

BUY IT NOW!

Click Here To Order

PayPal American Express Discover MasterCard VISA

REPLACEMENT OF FUSES/ CIRCUIT BREAKERS

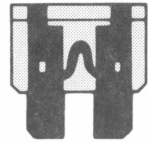

GOOD FUSE

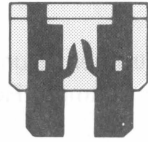

BLOWN FUSE

Fuses are mounted either in the **Fuse Panel** or in-line. They are identified by the numbered value in amperes, and by a color code. Some positions may have either a fuse with adapter or a circuit breaker. Be sure to replace a fuse or circuit breaker with the same kind of unit and with the same ampere rating. Remove fuses in order to check them.

CIRCUIT BREAKER OPERATION

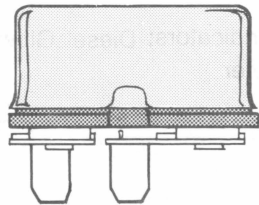

EXTERNAL
SIDE VIEW

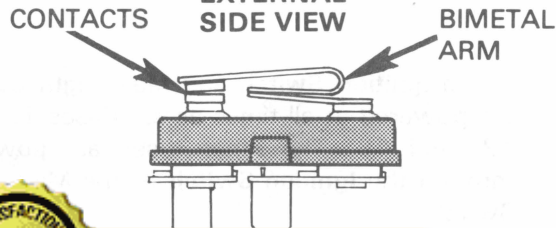

CONTACTS

BIMETAL
ARM

100% SATISFACTION GUARANTEED

BUY IT NOW!

Click Here To Order

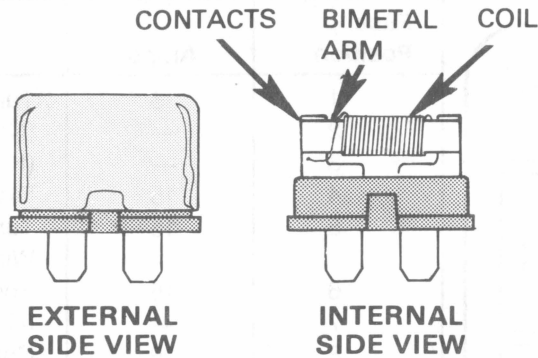

Non-Cycling Fuse Block Type



Cycling In-Line Type

Some circuits are protected by circuit breakers. (Abbreviated "c.b." in fuse chart.) They can be **Fuse Panel** mounted or in-line. Like fuses, they are rated in amperes.

Each circuit breaker conducts current through an arm made of two types of metal bonded together (bimetal arm). If the arm starts to carry too much current, it heats up. As one metal expands faster than the other, the arm bends, opening the contacts. Current flow is broken. In the cycling type, the arm cools and straightens out. This closes the circuit again. This cycle repeats as long as the overcurrent exists, with power applied.

In the non-cycling type, there is also a coil wrapped around the bimetal arm. When an overcurrent exists and the contacts open, a small current passes through the coil. This current through the coil is not large enough to

FUSE LINKS

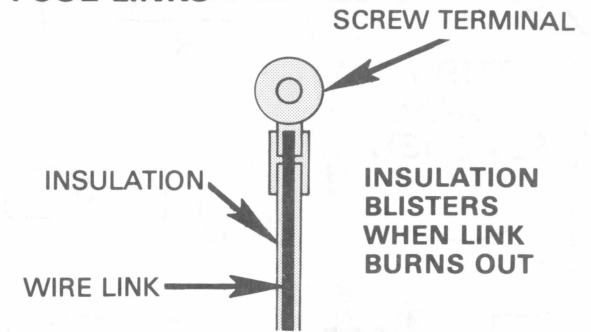

operate a load, but it does heat up both the coil and bimetal arm. This keeps the arm in the open position until power is removed.

The fuse link is a short length of wire smaller in gage than the wire in the protected circuit. The wire is covered with a thick non-flammable insulation. An overload causes the link to heat and the insulation to blister. If the overload remains, the link will melt, causing an open circuit.

When replacing, make tight crimp joints or hot solder joints for good connections.

DIODES

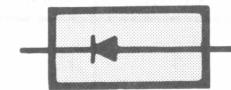

Diodes are electrical devices that permit current to flow in one direction only. The current flows in the direction indicated by the arrow.

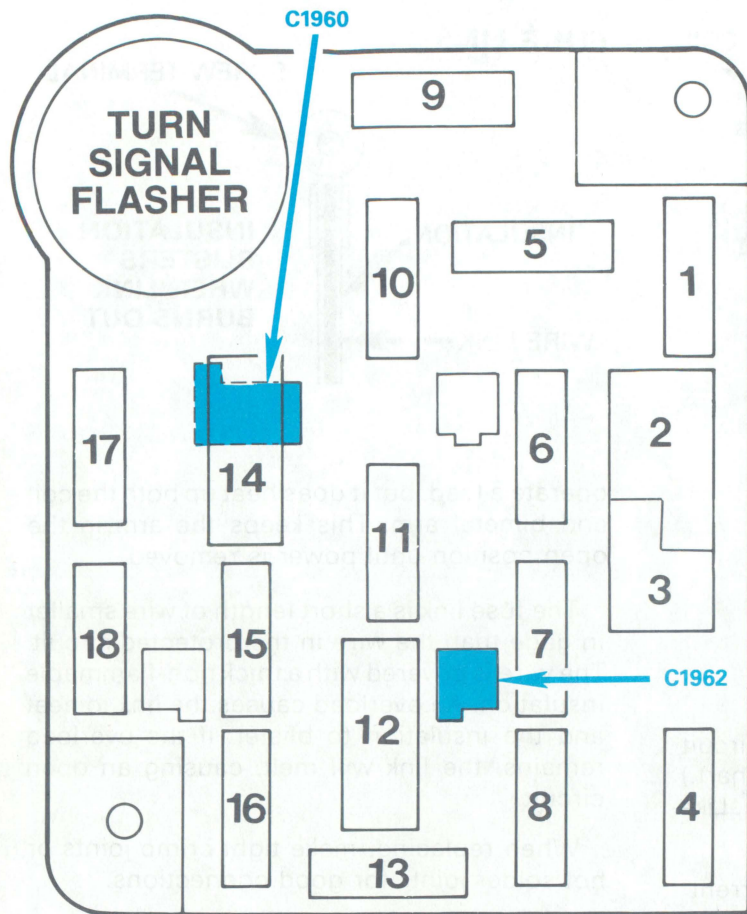

Figure 1 - Fuse Panel

Fuse Position	Amps	Circuits Protection
1	15	Turn/Stop/Hazard Lamps; Speed Control
2	—	(Not used)
3	—	(Not used)
4	15	Exterior Lamps; Instrument Illumination
5	15	Turn Lamps; Backup Lamps; Rear Window Defrost
6	15	Speed Control; Electronic Shift-4 Wheel Drive
7	—	(Not Used)
8	15	Courtesy, Dome, Cargo Lamps; Warning Buzzer
9	30	Heater; A/C-Heater
10	5	Instrument Illumination; Clock Dimming
11	15	Radio; Main Light Switch; Clock Illumination
12	25	Tailgate Power Window; Power Mirrors
13	30 c.b.	Power Door Locks; Electronic Shift-4 Wheel Drive
14	—	(Not used)
15	25	Tailgate Power Window
16	30 c.b.	Power Windows
17	10	Auxiliary Fuel Tank Selector
18	30	Horn; Cigar Lighter; Speed Control; 4.9L EFI After Run Blower
19	20	Anti-lock Brakes
20	15	Seatbelt Buzzer; Warning Indicators; Diesel Glow Plug Control; Diesel Indicators; Tachometer

Fuse Value Amps	Color Code
4	Pink
5	Tan
10	Red

Power Distribution

The Alternator and Battery are connected together at the Starter Relay hot terminal. Other circuits originate at the Starter Relay hot terminal and are protected by fuse links. Low power circuits are also protected by fuses.

The Ignition Switch and Main Light Switch are powered at all times as are Fuses 1, 4, 8, 12, and 16. The other fuses are powered through the Ignition Switch or the Main Light Switch.

100% SATISFACTION GUARANTEED

BUY IT NOW!

Click Here To Order

PayPal, American Express, Discover, MasterCard, VISA

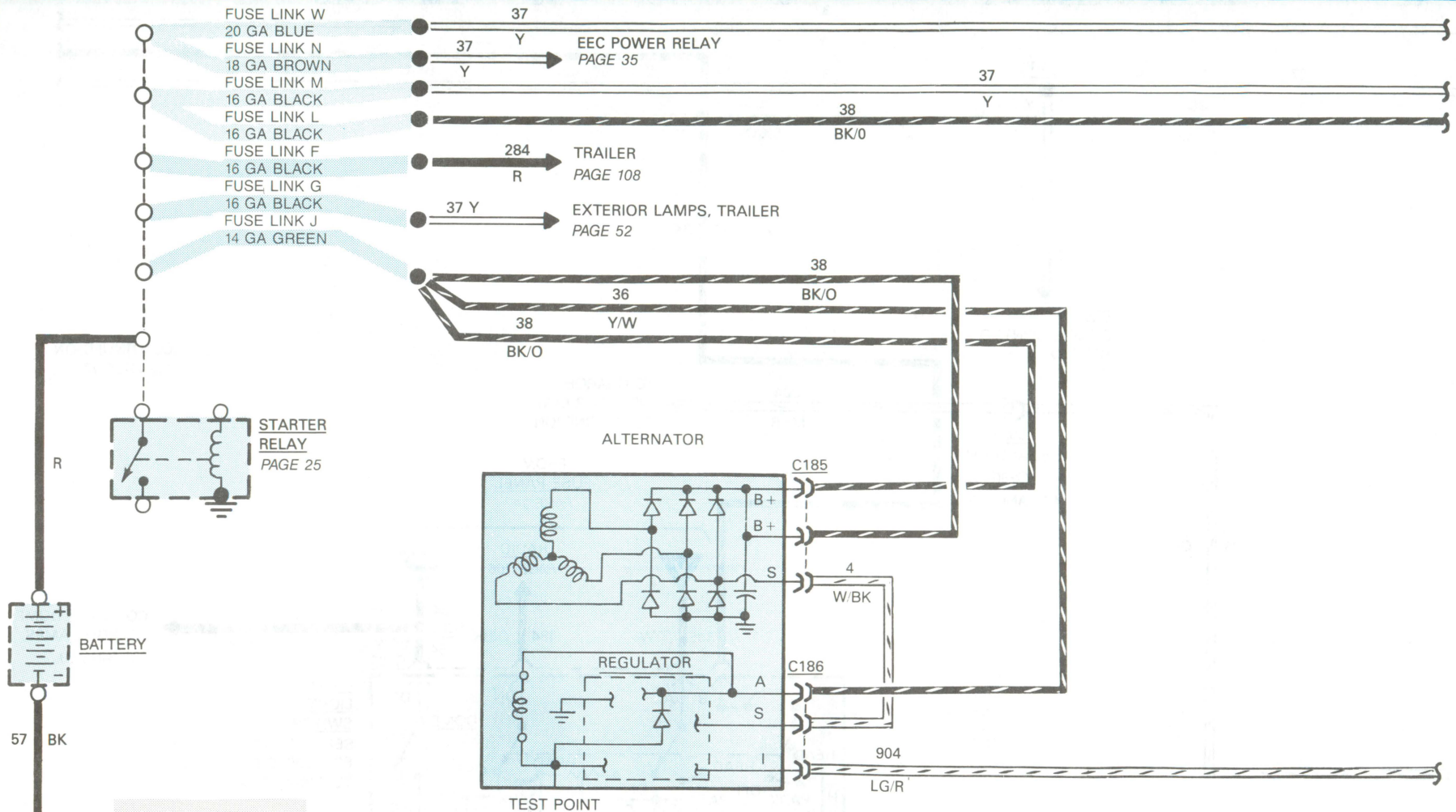

NOTE (FUSE LINE J)
 14 GA WITH 70 AMP
 ALTERNATOR 16 GA
 WITH 60 AMP
 ALTERNATOR.



BUY IT NOW!

[Click Here To Order](#)



16 CHARGE/POWER DISTRIBUTION (GASOLINE)

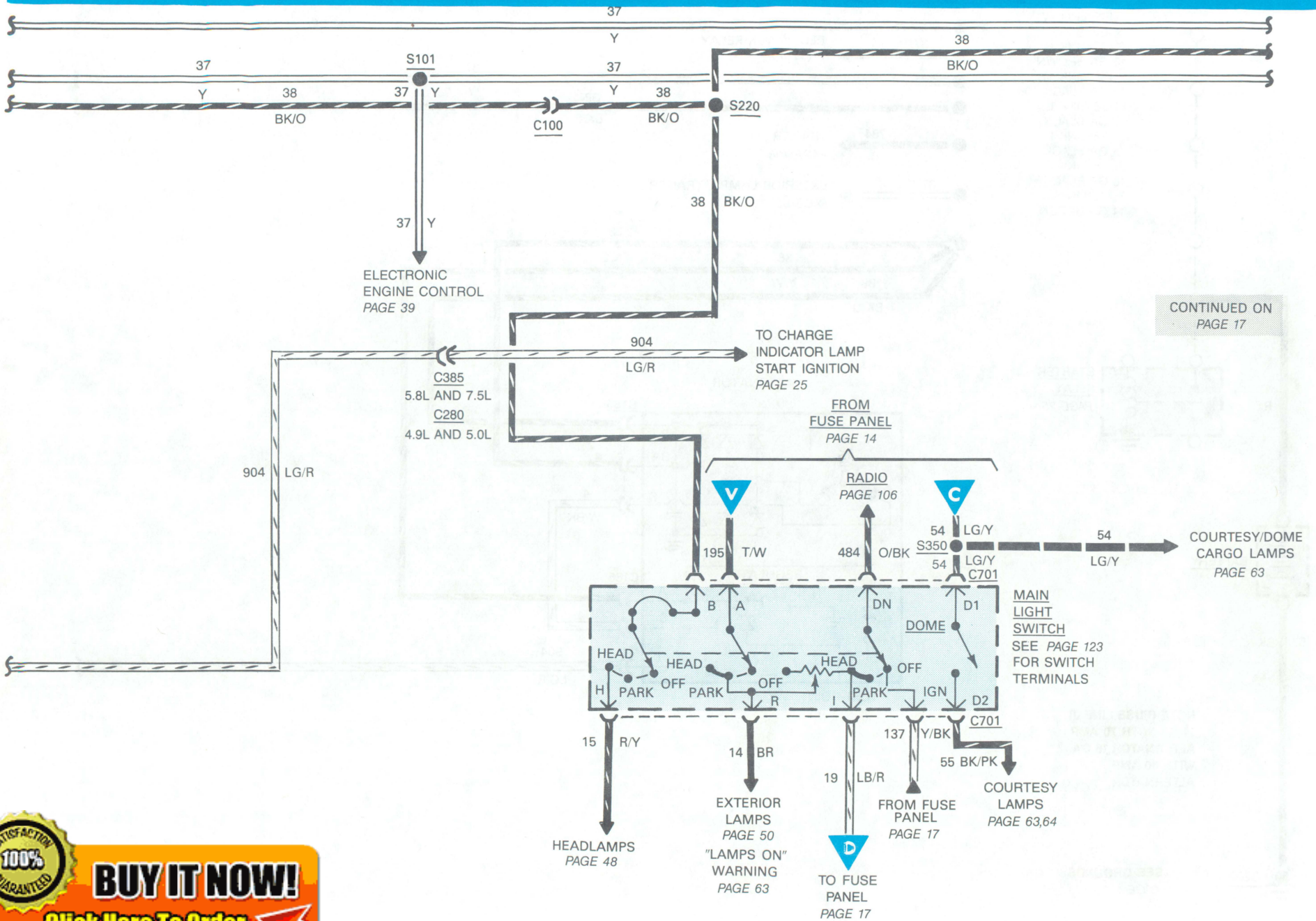

CONTINUED ON
PAGE 17

SATISFACTION 100% GUARANTEED

BUY IT NOW!

Click Here To Order

HOW THE CIRCUIT WORKS

The **Battery**, **Alternator** and **Voltage Regulator** make up the **Charging System**. With the **Ignition Switch** in **RUN**, **Battery** voltage is applied through the solid-state electronic control of the **Voltage Regulator**. The electronic control applies **Battery** voltage to the **Alternator** field.

With current in the field and the rotor turning, the **Alternator** stator produces a DC voltage at B+ terminals (to **Battery**). If the **Alternator** output voltage is greater than the **Battery** terminal voltage, current will flow from the **Alternator** to the **Battery**, as well as to the vehicle electrical load.

If the **Alternator** voltage is less than the **Battery** terminal voltage, current will flow from the **Battery** to supplement the alternator output in supplying the vehicle electrical load.

Refer to section 31-01 of the shop manual.

COMPONENT LOCATION

Page-
Figure

Fuse Links F, G, J, L, M, N, W	Near starter relay
Radio Noise Capacitor ...	Attached to voltage regulator
Starter Relay	On RH fender apron

Refer to the **Location Index** in the back of the manual for connector, ground, and splice descriptions and locations.

TROUBLESHOOTING HINTS

CONDITION	POSSIBLE CAUSE	ACTION
<ul style="list-style-type: none"> Improper Charging 	<ul style="list-style-type: none"> Loose/worn alternator belt Defective/dead battery Fuse Link J open at starter relay Poor connection between battery terminals and cable clamps/damaged cables 	<ul style="list-style-type: none"> Tighten/replace Replace battery Visually check for open in link, replace Clean, tighten and/or replace
<ul style="list-style-type: none"> Alternator Warning Indicator remains on after initial start up 	<ul style="list-style-type: none"> Poor connection on Alternator, Regulator, Starter Relay, and/or Alternator Output Control Relay 	<ul style="list-style-type: none"> Make sure connections are tight and free of debris and refer to shop manual section 31-01, Charging System Diagnosis



BUY IT NOW!

Click Here To Order



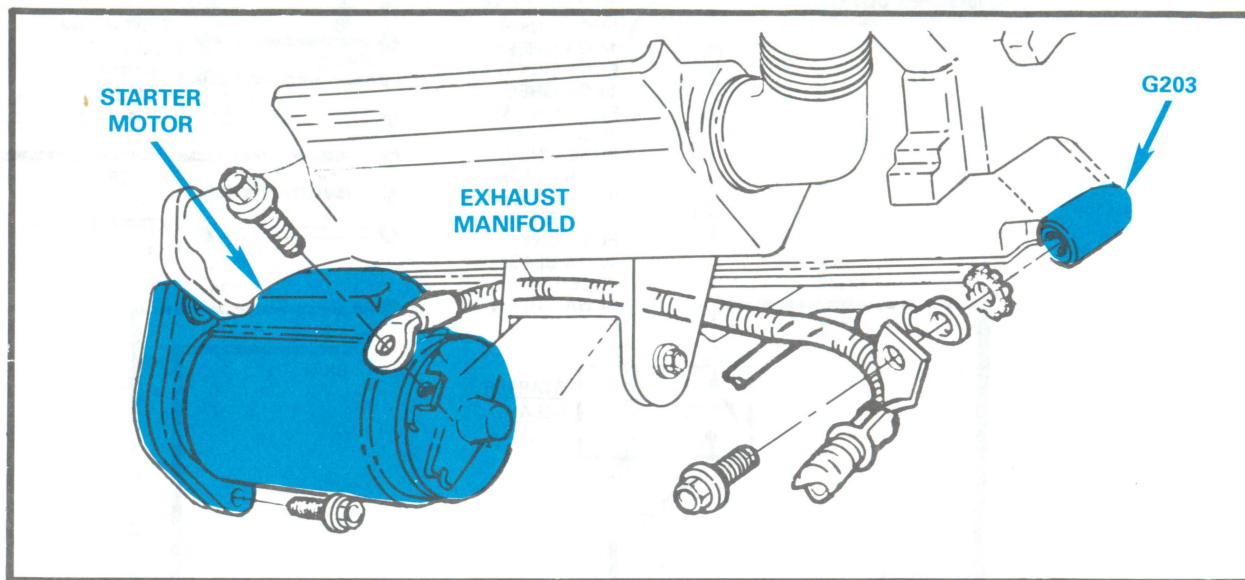

Figure 1 — Lower RH Side of Engine (5.0L, 5.8L, 7.5L, 8 Cyl.)

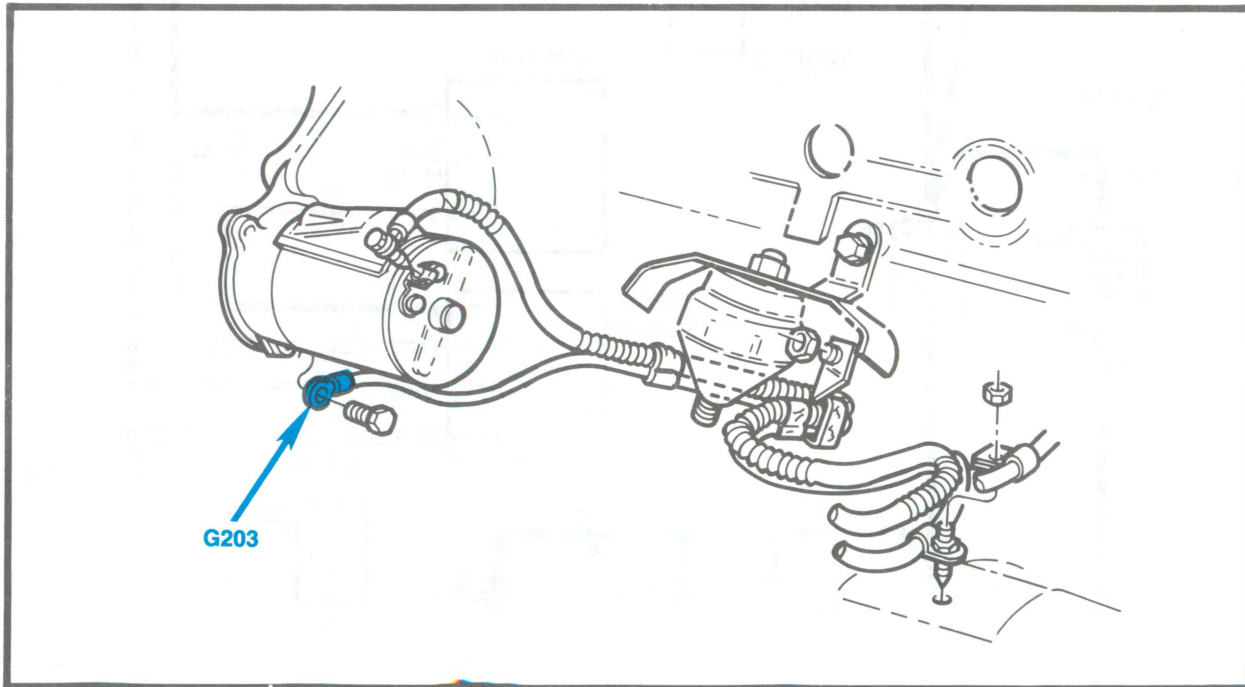

Figure 2 — Lower RH Side of Engine (4.9L 6 Cyl. ONLY)

100% SATISFACTION GUARANTEED

BUY IT NOW!

Click Here To Order

PayPal American Express Cards DISCOVER NOVUS MasterCard VISA

20 CHARGE/POWER DISTRIBUTION (DIESEL)

F-250/SUPER DUTY

- FUSE LINK W 20 GA BLUE
- FUSE LINK B 14 GA GREEN
- FUSE LINK C 14 GA GREEN
- FUSE LINK M 16 GA BLACK
- FUSE LINK L 16 GA BLACK
- FUSE LINK F 16 GA BLACK
- FUSE LINK G 16 GA BLACK
- FUSE LINK J 14 GA GREEN

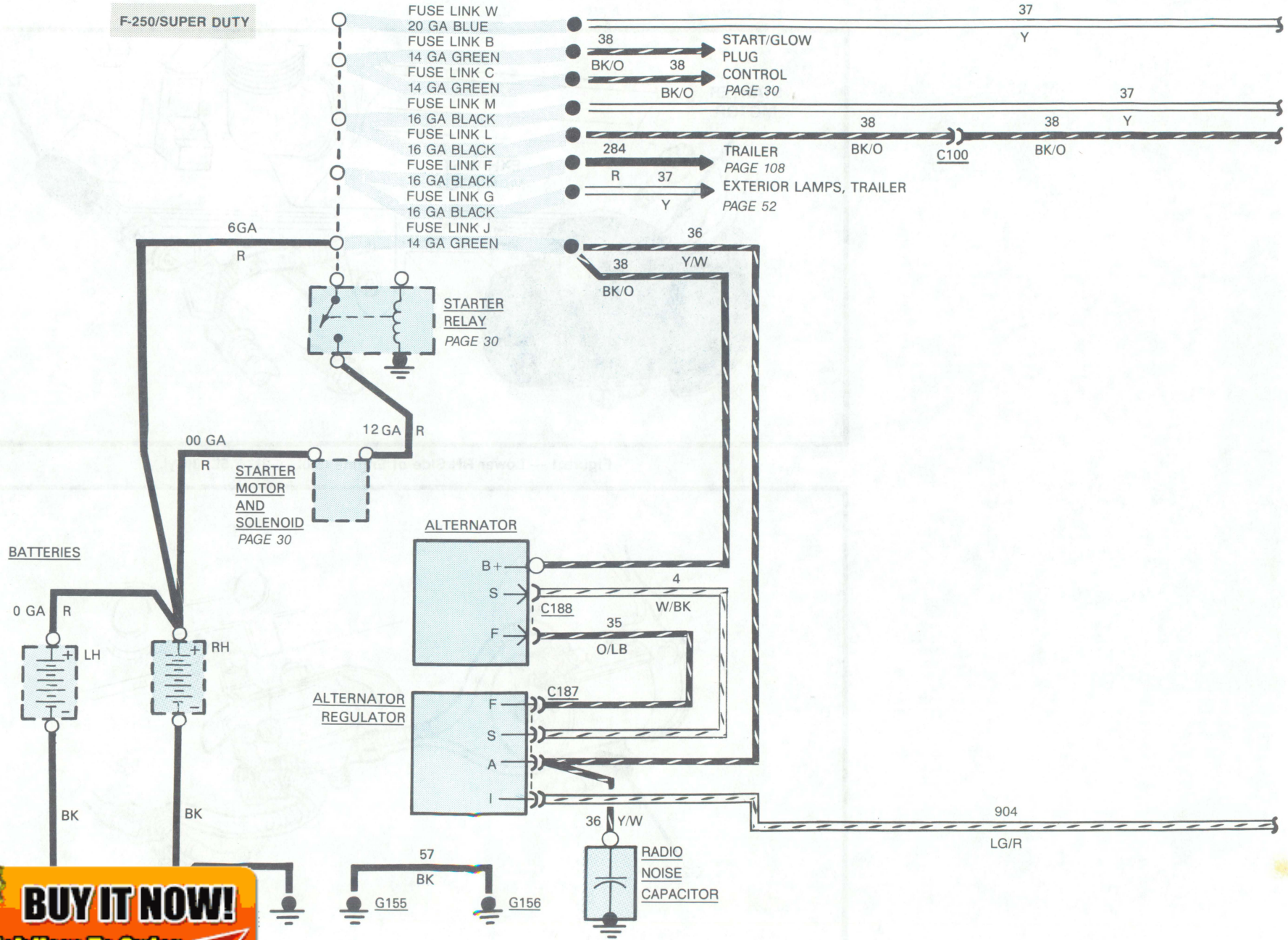

100% SATISFACTION GUARANTEED

BUY IT NOW!

Click Here To Order



**WE SUPPORT VOLUNTARY
TECHNICIAN CERTIFICATION**



**Ford Parts and Service Division
Training and Publications Department**

100% SATISFACTION GUARANTEED

BUY IT NOW!

Click Here To Order 

PayPal    

