

1987 MUSTANG

Available on
Kindle
MasterCard
VISA
Buy It Now!
Free To Order

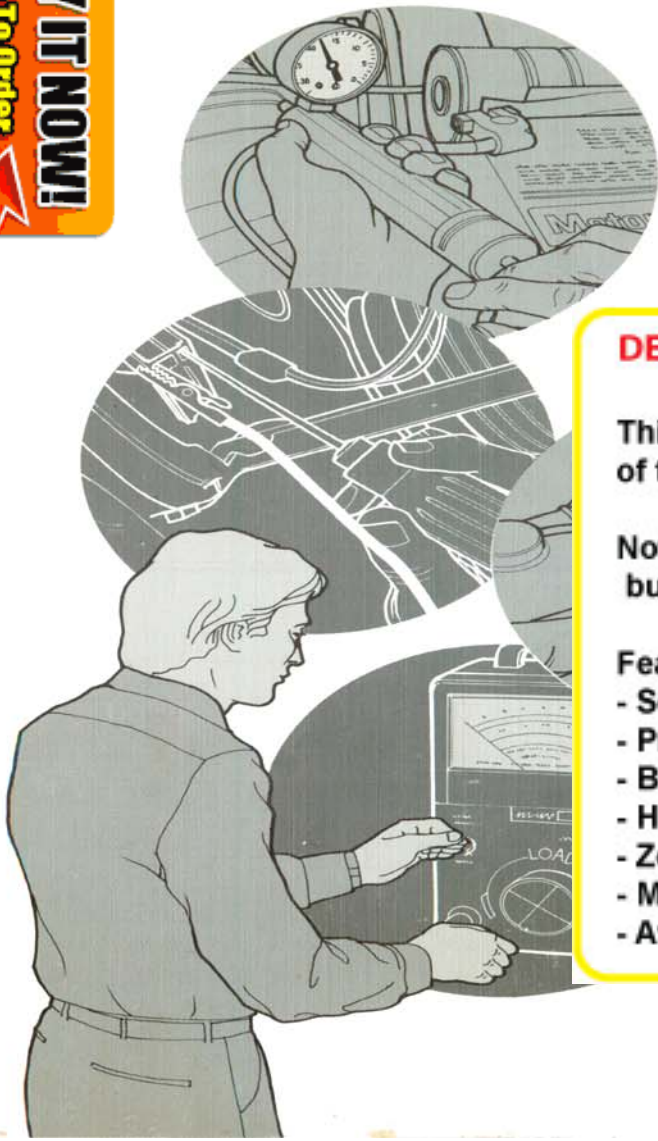

1987 MUSTANG

DEMO

This DEMO contains only a few pages of the entire manual/product.

Not all Bookmarks work on the Demo, but they do on the full version.

Features:

- Searchable text
- Printable pages
- Bookmarked for easy navigation
- High Resolution images
- Zoom to see exact details
- Money back Guarantee
- Available on USB and eBook download

Ford



Ford

Official
Licensed
Product

License #84356800

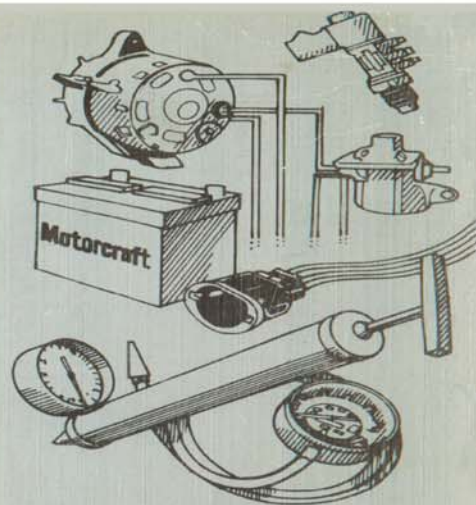

Electrical & Vacuum Trouble- Shooting Manual

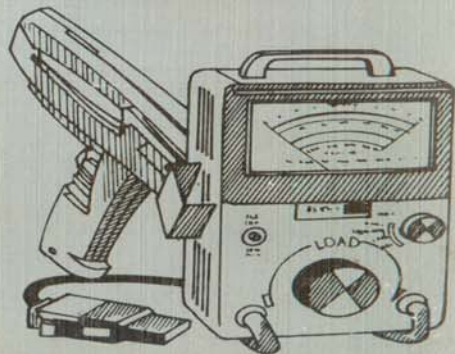

Copyright © 2023, Forel Publishing Company, LLC, Woodbridge, Virginia

All Rights Reserved. No part of this book may be used or reproduced in any manner whatsoever without written permission of Forel Publishing Company, LLC. For information write to Forel Publishing Company, LLC, Woodbridge, VA 22192

**1987 Mustang Electrical & Vacuum Trouble-Shooting
Manual (EVTM)
EAN: 978-1-60371-398-6
ISBN: 1-60371-398-0**

Forel Publishing Company, LLC
Woodbridge, VA 22192
Email: sales@ForelPublishing.com
<https://www.ForelPublishing.com>



This publication contains material that is reproduced and distributed under a license from Ford Motor Company. No further reproduction or distribution of the Ford Motor Company material is allowed without the express written permission of Ford Motor Company.

Note from the Publisher

This product was created from the original Ford Motor Company's publication. Every effort has been made to use the original scanned images, however, due to the condition of the material; some pages have been modified to remove imperfections.

Disclaimer

Although every effort was made to ensure the accuracy of this book, no representations or warranties of any kind are made concerning the accuracy, completeness or suitability of the information, either expressed or implied. As a result, the information contained within this book should be used as general information only. The author and Forel Publishing Company, LLC shall have neither liability nor responsibility to any person or entity with respect to any loss or damage caused, or alleged to be caused, directly or indirectly by the information contained in this book. Further, the publisher and author are not engaged in rendering legal or other professional services. If legal, mechanical, electrical, or other expert assistance is required, the professional should be sought.



The purpose of this manual is to show electrical and vacuum circuits of these vehicles in a clear and simple fashion to make troubleshooting easier. With each circuit is a description of *How the Circuit Works* and some *Troubleshooting Hints*. A *Component Location* chart lists components, connectors, and references to pictures in the manual.

Wiring Diagrams give a schematic picture of when and how the circuit is powered, what the current path is to circuit components, and how the circuit is grounded. Each circuit component is named (underlined titles). Wire and connector colors are listed (standard Ford color abbreviations are used):

COLOR ABBREVIATIONS

BL	Blue	N	Natural
BK	Black	O	Orange
BR	Brown	PK	Pink
DB	Dark Blue	P	Purple
DG	Dark Green	R	Red
GR	Green	T	Tan
GY	Gray	W	White
LB	Light Blue	Y	Yellow
LG	Light Green		

Where two colors are shown for a wire, the first color is the basic color of the wire. The second color is the stripe marking. It should be noted that the use of dots and hashes for circuit identification has been eliminated. Dots may still be used for identification. The letter has been eliminated as an identifier, and

Connector end views of switches and other components are shown to help with bench testing. The views show the harness wire colors that connect to the mating terminals. Connector colors and locations are shown in the *Component Location* chart. Two-color listings indicate separate colors for each connector half.

Components which work together are shown together. For example, all electrical components used in any circuit are shown on one diagram. The circuit breaker or fuse is shown at the top of the page. All wires, connectors, splices, switches, and motors are shown in the flow of current to ground at the bottom of the page. Notes are included which describe how switches and other components work. If a component is used in several different circuits, it is shown in several different schematics. For example, the **Light Switch** is an electrical part of many circuits and is repeated on many pages. In some cases, however, a component may seem by its name to belong on a page where it has no electrical connection. For example, **Radio Illumination** is electrically part of **Instrument Illumination**. Since it has no electrical connection at all with the actual **Radio** circuit, it is not shown on the **Radio** page.

Troubleshooting Hints point the technician in a general direction, but are not intended as a step-by-step procedure. Ignition troubleshooting is an exception to this. It includes a step-by-step procedure of basic quick checks to locate some of the more common **Ignition System** problems. Read the Shop Manual for more detailed repair procedures.

The **Grounds** pages show detailed views of multiple component ground points. This is useful for checking interconnections among the ground circuits of different diagrams.

Notes, Cautions, and Warnings appear in boxes on text pages and contain important car and mechanic safety information.

Notes give added information to help complete a particular procedure. Cautions are included to prevent making an error that could damage the vehicle. Warnings highlight areas where carelessness can cause personal injury. The following list contains some general **Warnings** that should be followed when working on a vehicle.

- Always wear safety glasses for eye protection.
- Use safety stands whenever a procedure requires being under a vehicle.
- Be sure that the **Ignition Switch** is always in the OFF position, unless otherwise required by the procedure.
- Set the parking brake when working on any vehicle. An automatic transmission should be in PARK. A manual transmission should be in NEUTRAL.
- Operate the engine only in a well-ventilated area to avoid the danger of carbon monoxide.
- Keep away from moving parts when the engine is running, especially the fan and belts.
- To prevent serious burns, avoid contact with hot metal parts such as the radiator, exhaust manifold, tail pipe, catalytic converter, and muffler.
- Do not allow flame or sparks near the battery. Gases are always present in and around the battery cell. An explosion could occur.
- Do not smoke.
- To avoid injury, always remove rings, watches, loose hanging jewelry, and loose clothing.

2 HOW TO FIND THE ELECTRICAL PROBLEM

TROUBLESHOOTING STEPS

These six steps present an orderly method of troubleshooting:

Step 1. Verify the problem.

- Operate the complete system and see all symptoms for yourself in order to:
 - check the accuracy and completeness of the customer's complaint.
 - learn more that might give a clue to the nature and location of the problem.

Step 2. Narrow the problem.

- Using the EVTM, narrow down the possible causes and locations of the problem in order to more quickly find the exact cause.
- Read the description of *How the Circuit Works* and study the wiring diagram. You should then know enough about the circuit operation to figure out where to check for this trouble.

Step 3. Test the cause.

- Use electrical test procedures to find the specific cause of the symptoms.
- *Troubleshooting Hints* will give some helpful ideas.
- The *Component Location* charts and the pictures will help you find components, grounds, and connectors.

Step 4. Verify the cause.

- Confirm the fact that you have found the correct cause through operating the parts of the circuit you think are good.

Step 5. Make the repair.

- Repair or replace the faulty component.

Step 6. Verify the repair.

- Operate the system as in Step 1 and check for all symptoms, including any new symptoms.

100% SATISFACTION GUARANTEED

BUY IT NOW!

Click Here To Order

PayPal American Express Discover Novus MasterCard VISA

details. You will find the circuits in this manual to be helpful with these special tests.

TROUBLESHOOTING TOOLS

JUMPER WIRE

This is a test lead used to connect two points of a circuit. A **Jumper Wire** can complete a circuit by bypassing an open.

Uses: Bypassing Switches or Open Circuits

WARNING

Never use a jumper wire across high resistance loads (motors, etc.) connected between hot and ground. This direct battery short may cause injury or fire.

VOLTMETER

A DC **Voltmeter** measures circuit voltage. Connect negative (- or black) lead to ground, and positive (+ or red) lead to voltage measuring point.

OHMMETER

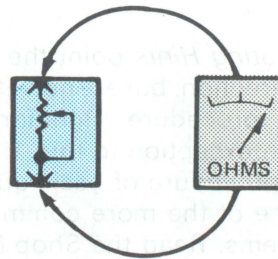

Figure 1—Resistance Check

An **Ohmmeter** shows the resistance between two connected points (Figure 1).

TEST LAMP

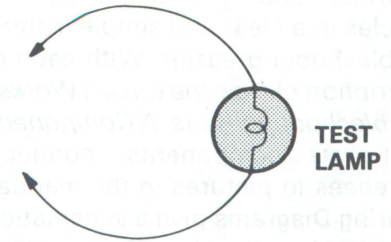

Figure 2—Test Lamp

A **Test Lamp** is a 12-volt bulb with two test leads (Figure 2).

Uses: Voltage Check. Short Check

SELF-POWERED TEST LAMP

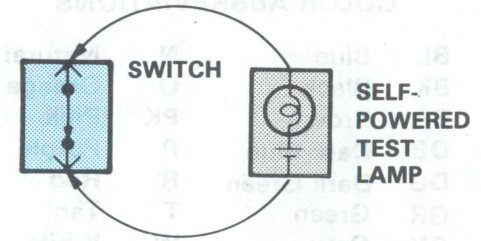

Figure 3—Continuity Check

The **Self-Powered Test Lamp** is a bulb, battery and set of test leads wired in series (Figure 3). When connected to two points of a continuous circuit, the bulb glows.

Uses: Continuity Check. Ground Check

CAUTION

When using a self-powered test lamp or ohmmeter, be sure power is off in circuit during testing. Hot circuits can cause equipment damage and false readings.

TROUBLESHOOTING CHECKS

SWITCH CIRCUIT CHECK

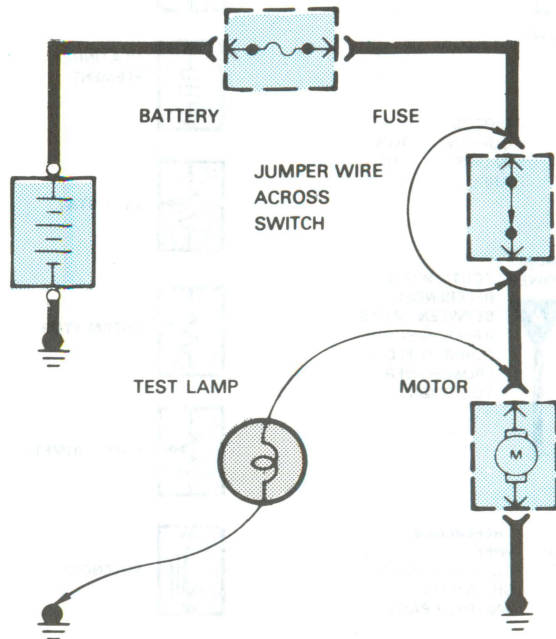

Figure 4—Switch Circuit Check and Voltage Check

In a bad circuit with a switch in series with the load, jumper the terminals of the switch to power the load. If jumping the terminals powers the circuit, the switch is bad (Figure 4).

CONTINUITY CHECK (Locating open circuits)

Connect one lead of **Self-Powered Test Lamp** or **Ohmmeter** to each end of circuit (Figure 3). Light will glow if circuit is closed. Switches and fuses can be checked in the same way.

VOLTAGE CHECK

a known
) battery
the other
when the

SHORT CHECK (short to ground)

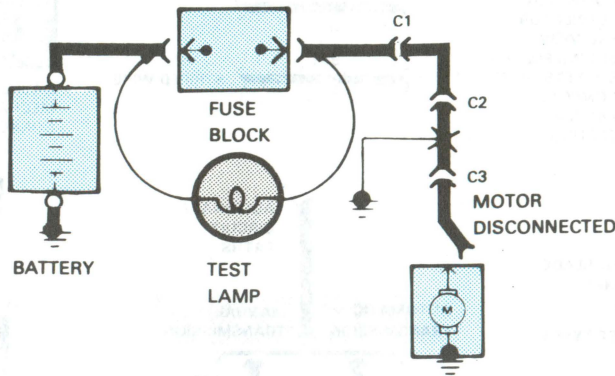

Figure 5—Short Check

A fuse that repeatedly blows is usually caused by a short to ground. It's important to be able to locate such a short quickly (Figure 5).

- 1) Turn off everything powered through the fuse.
- 2) Disconnect other loads powered through the fuse:
 - **Motors:** disconnect motor connector.
 - **Lamps:** remove bulbs.
- 3) Turn **Ignition Switch** to RUN (if necessary) to power fuse.
- 4) Connect one **Test Lamp** lead to hot end of blown fuse. Connect other lead to ground. Bulb should glow showing power to fuse. *(This step is just a check to be sure you have power to the circuit.)*
- 5) Disconnect the **Test Lamp** lead from ground and reconnect it to the load side of the fuse.
 - If the **Test Lamp** is off, the short is in the disconnected equipment.
 - If the **Test Lamp** goes on, the short is in the wiring. You must find the short by disconnecting the circuit connectors one at a time until the **Test Lamp** goes out. For example: with a ground at X, the bulb goes out when C1 or C2 is disconnected, but stays on after disconnecting C3. This

means the ground is between C2 and C3.

"GOOD GROUND" CHECK

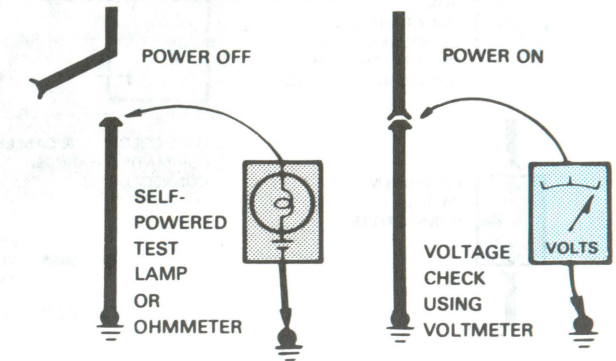

Figure 6—Grounds Checks

Turn on power to circuit. Perform Voltage Check between suspected bad ground and frame. Any voltage means ground is bad.

Turn off power to circuit. Connect one lead of **Self-Powered Test Lamp** or **Ohmmeter** to wire in question, and the other to known ground. If bulb glows, circuit ground is OK (Figure 6).

TROUBLESHOOTING HINTS

The circuit schematics in this manual are designed to make it easy to identify common points in circuits. This knowledge can help narrow the problem to a specific area. For example, if several circuits fail at the same time, check for a common power or ground connection. (See *Power Distribution* or *Grounds*). If part of a circuit fails, check the connections between the part that works and the part that doesn't work.

For example, if low beam **headlamps** work, but high beams and the indicator light don't work, then power and ground paths must be good. Since the dimmer switch is the component which switches this power to the high beam **lamps** and indicator, it is most likely the cause of failure.

100% SATISFACTION GUARANTEED

BUY IT NOW!

Click Here To Order

PayPal, American Express, Discover, MasterCard, VISA

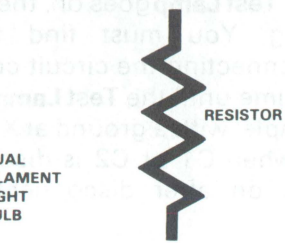
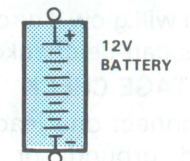
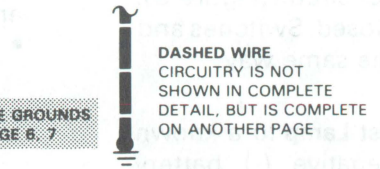
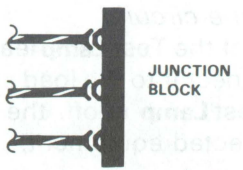
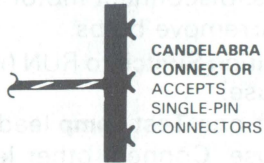
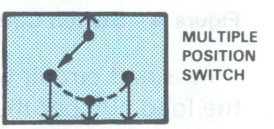
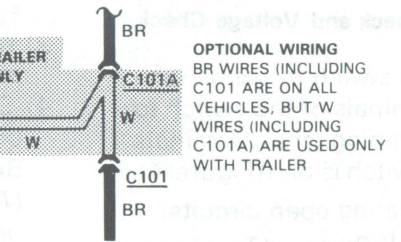
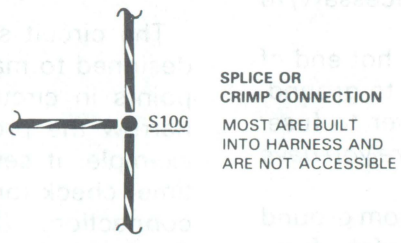
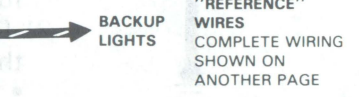
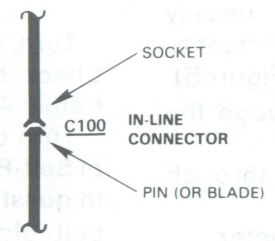
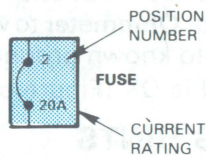
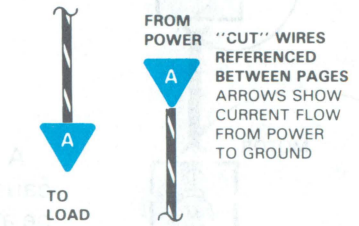
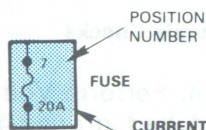
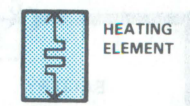
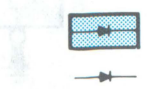
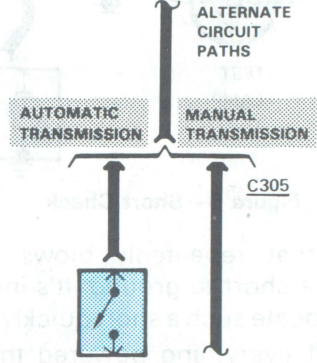
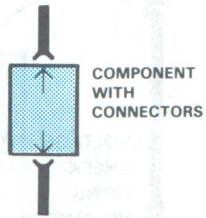
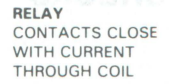
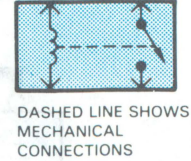
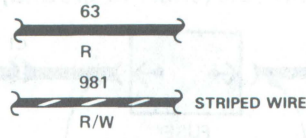
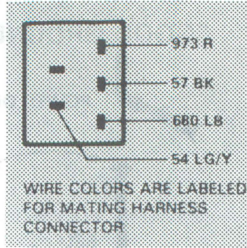
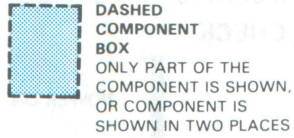

100% SATISFACTION GUARANTEED

BUY IT NOW!

Click Here To Order

PayPal Discover MasterCard VISA

SEALED ELECTRONIC COMPONENT
ANY CIRCUITRY SHOWN INSIDE THE BOX IS A FUNCTIONAL

INSTRUMENT PANEL GROUND

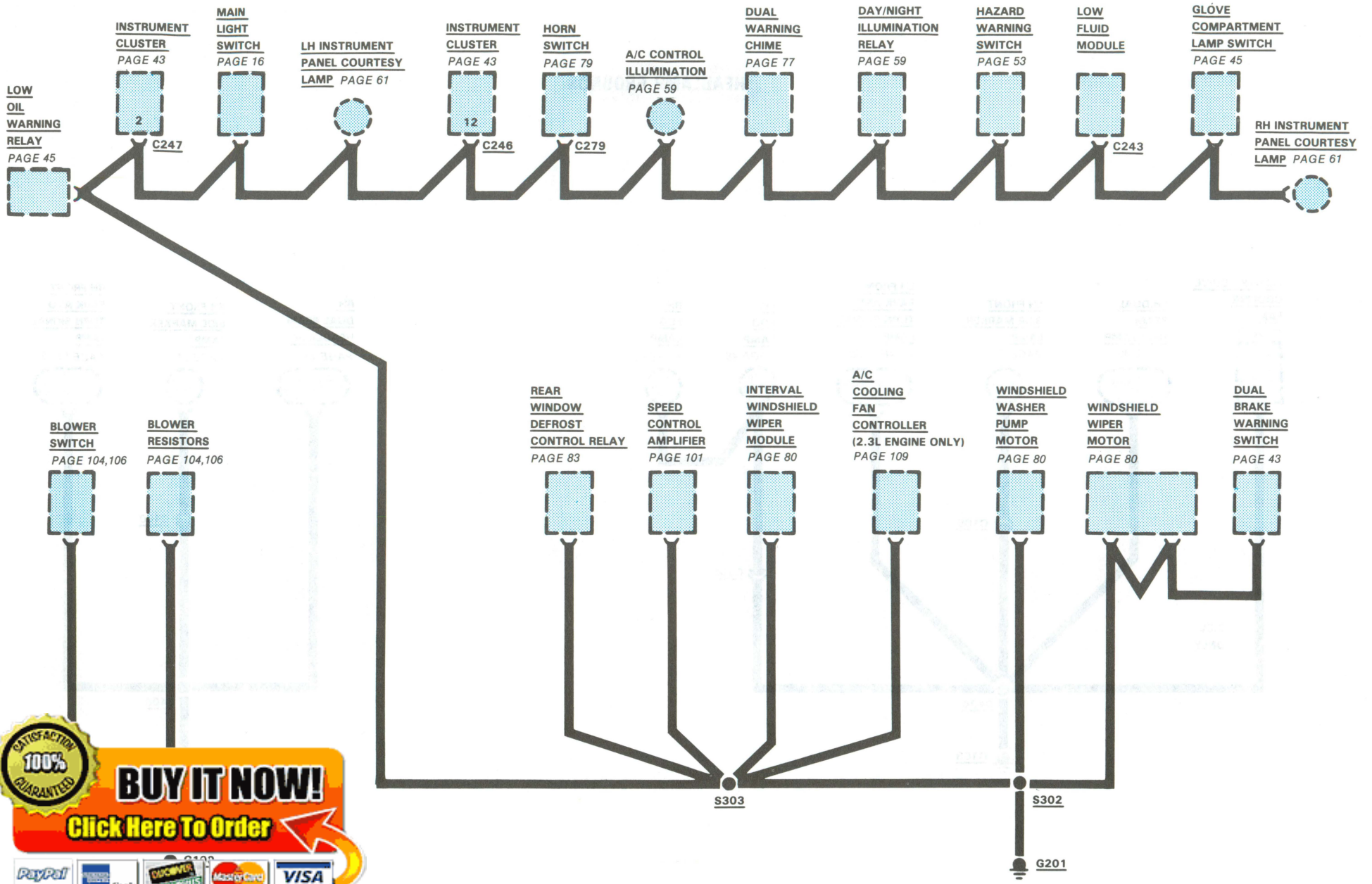

SATISFACTION 100% GUARANTEED

BUY IT NOW!

Click Here To Order

PayPal American Express Discover MasterCard VISA

HEADLAMP GROUNDS

**ELECTRO-DRIVE
COOLING
FAN**
PAGE 109



**LH DUAL
BEAM
HEADLAMP**
PAGE 48



**LH FRONT
SIDE MARKER
LAMP**
PAGE 51



**LH FRONT
PARK AND
TURN SIGNAL
LAMP**
PAGE 51,53



**LH
FOG
LAMP**
PAGE 48



**RH
FOG
LAMP**
PAGE 48



**RH
DUAL BEAM
HEADLAMP**
PAGE 48



**RH FRONT
SIDE MARKER
LAMP**
PAGE 51



**RH FRONT
PARK AND
TURN SIGNAL
LAMP**
PAGE 51,53



2.3L
ONLY

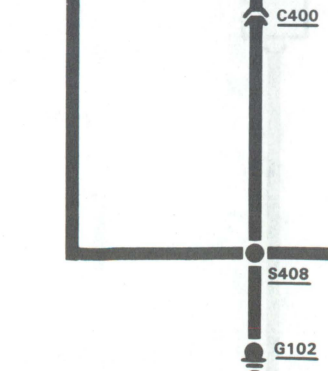

100% SATISFACTION GUARANTEED

BUY IT NOW!

Click Here To Order

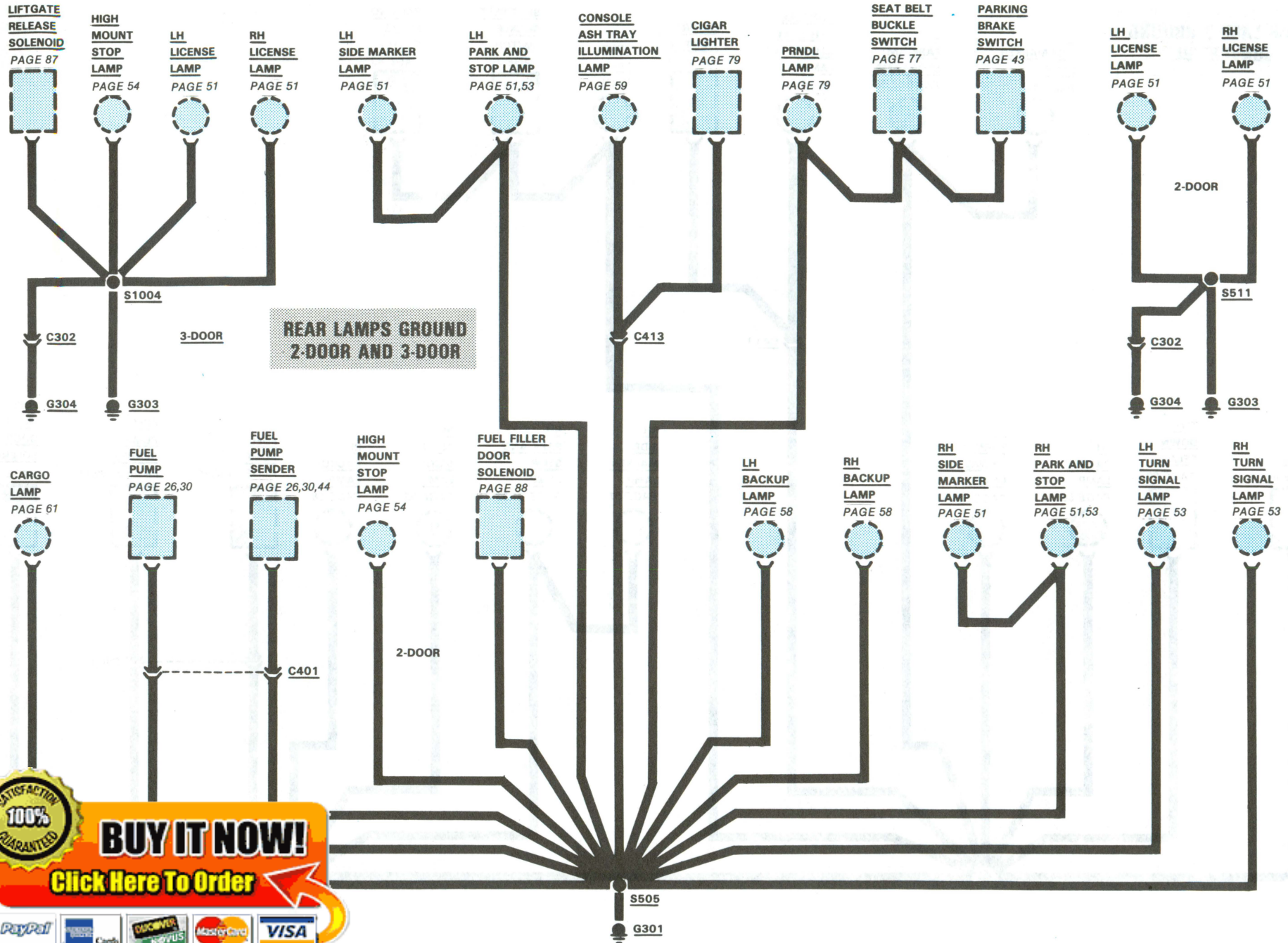

**REAR LAMPS GROUND
2-DOOR AND 3-DOOR**

100% SATISFACTION GUARANTEED

BUY IT NOW!

Click Here To Order

REAR LAMPS GROUND CONVERTIBLE

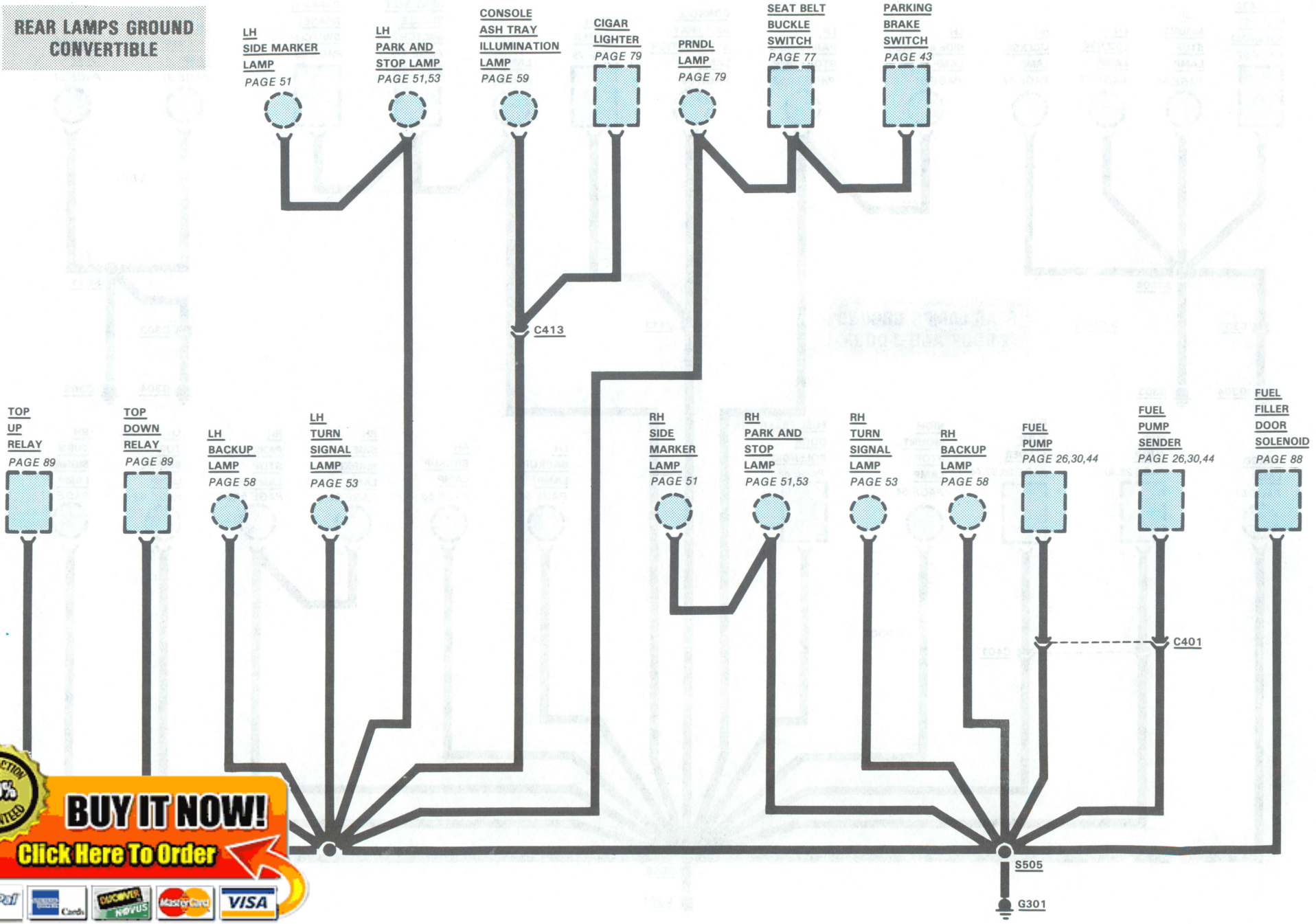

100% SATISFACTION GUARANTEED

BUY IT NOW!

Click Here To Order

PayPal American Express Cards Discover MasterCard VISA

COMPONENT LOCATION

		Page-Figure	Color	Terminals
Connector C106	Near LH headlamp		BK	2
Connector C302	LH corner of liftgate behind sight plug	86-3	GY	3
Connector C362	Near LH front side marker lamp		GY	2
Connector C400	Near RH headlamp		GY	2
Connector C401	Near fuel pump and sender	42-7	BK	4
Ground G100	A/C ground			
Ground G102	Top RH side of radiator support above headlamp			
Ground G103	Top LH side of radiator support above headlamp			
Ground G201	LH fender apron			
Ground G301	Near LH backup lamp			
Ground G303	LH corner of liftgate			
Ground G304	LH corner of liftgate			
Ground G500	Near T/O to park brake signal lamp switch			
Splice S302	Near T/O to G201			
Splice S303	Near windshield wiper T/O			
Splice S404	Near T/O to LH headlamp			
Splice S408	Near T/O to RH headlamp			
Splice S505	Near T/O to G301			
Splice S511	Near T/O to G303			
Splice S512	Near T/O to A/C heater blower switch			
Splice S1004	Near T/O to G303			

The ground circuits shown here are complete, and connect several components together to screw terminal ground points. On other pages only parts of these circuits may be shown. Partial ground circuits are shown dashed on those pages.

All simple or component ground circuits are shown on the individual circuit pages, and are complete on those pages.

All wires are **57 BK** unless otherwise noted.

100% SATISFACTION GUARANTEED

BUY IT NOW!

Click Here To Order 







10 FUSE PANEL/CIRCUIT PROTECTION

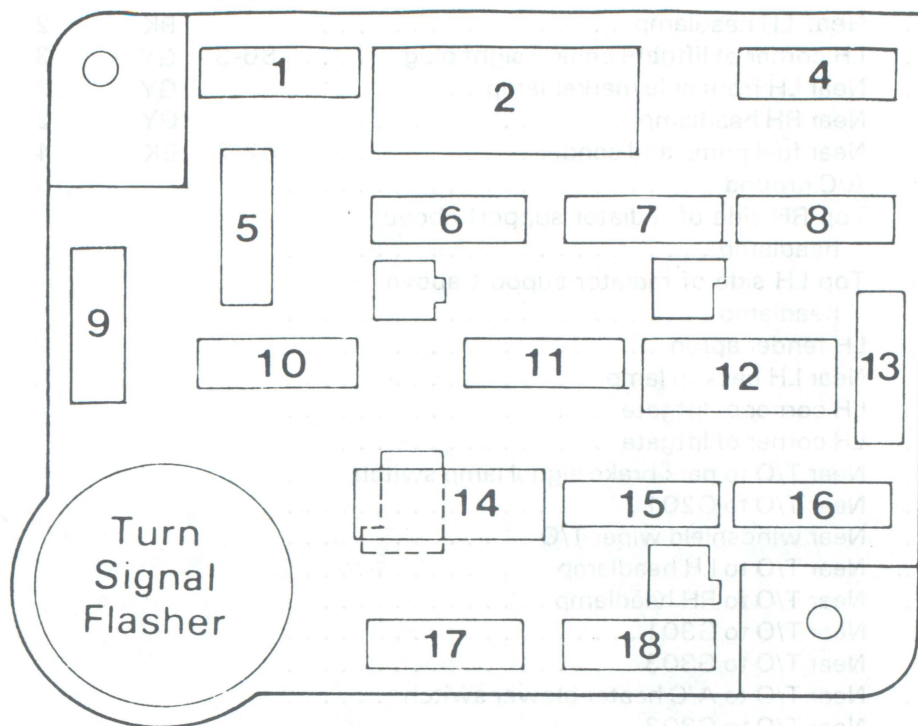

Fuse Position	Amps	Circuits Protected
1	15	Stop/Hazard Lamps; Speed Control
2	8.25 c.b.	Interval Wiper
4	10	Exterior Lamps; Instrument Illumination
5	15	Turn Lamps; Backup Lamps
6	20	Speed Control, Day/Night Illumination Relay; A/C; Decklid Release
7	—	(Not Used)
8	15	Courtesy Lamps; Dimmer Switch; Power Mirrors; Radio; Fuel Filler Door Release
9	30	Heater Blower; A/C Blower
10	20	Headlamps; Low Oil Level Warning
11	15	Radio; Premium Sound; Graphic Equalizer
12	—	(Not Used)
13	5	Instrument Illumination
14	20 c.b.	Power Windows
15	15	Fog Lamps
16	20	Horn; Cigar Lighter
17	—	(Not Used)
18	15	Seatbelt Buzzer; Warning Indicators; Low Coolant Switch; Low Fluid Monitor; Instrument Cluster

Fuse Value Amps	Color Code
4	Pink
5	Tan

100% SATISFACTION GUARANTEED

BUY IT NOW!

Click Here To Order

Power Distribution

The **Alternator** and **Battery** are connected together at the **Starter Relay** hot terminal. Other circuits originate at the **Starter Relay** hot terminal and are protected by fuse links. Low power circuits are also protected by fuses.

The **Ignition Switch** and **Main Light Switch** are powered at all times, as are **Fuses 1, 4, 8, 10 and 16**. The other fuses are powered through the **Ignition Switch** or the **Main Light Switch**.

Position **3** is not used, and is covered by **Circuit Breaker 2**.

REPLACEMENT OF FUSES/ CIRCUIT BREAKERS



GOOD FUSE

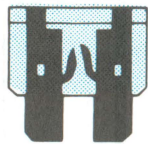

BLOWN FUSE

Fuses are mounted either in the **Fuse Panel** or in-line. They are identified by the numbered value in amperes, and by a color code. Some positions may have either a fuse with adapter or a circuit breaker. Be sure to replace a fuse or circuit breaker with the same kind of unit and with the same ampere rating. Remove fuses in order to check them.

CIRCUIT BREAKER OPERATION

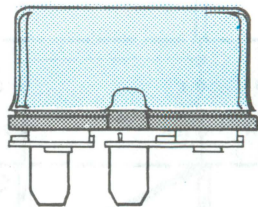

EXTERNAL
SIDE VIEW

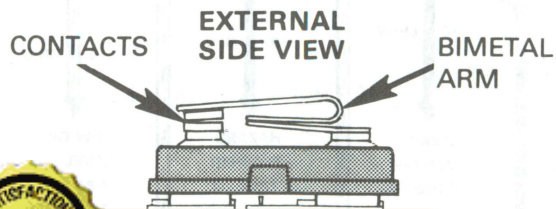

CONTACTS

BIMETAL
ARM

100% SATISFACTION GUARANTEED

BUY IT NOW!

Click Here To Order

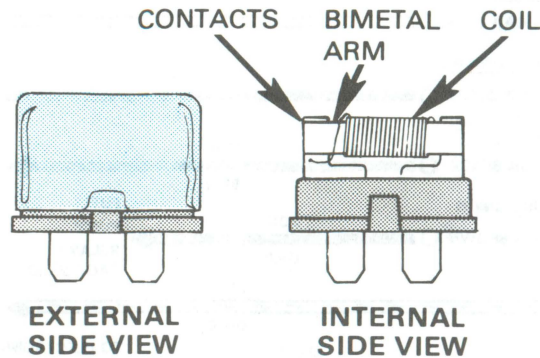

Non-Cycling Fuse Panel Type

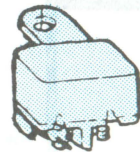

Cycling In-Line Type

Some circuits are protected by circuit breakers. (Abbreviated "c.b." in fuse chart.) They can be **Fuse Panel** mounted or in-line. Like fuses, they are rated in amperes.

Each circuit breaker conducts current through an arm made of two types of metal fastened together (bimetal arm). If the arm starts to carry too much current, it heats up. As one metal expands faster than the other the arm bends, opening the contacts. Current flow is broken. In the cycling type, the arm cools and straightens out. This closes the circuit again. This cycle repeats as long as the overcurrent exists, with power applied.

In the non-cycling type, there is also a coil wrapped around the bimetal arm. When an overcurrent exists and the contacts open, a small current passes through the coil. This current through the coil is not large enough to operate a load, but it does heat up both the coil and bimetal arm. This keeps the arm in the open position until power is removed.

FUSE LINKS

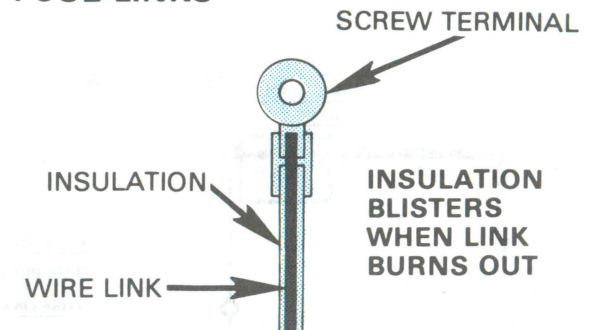

The fuse link is a short length of wire smaller in gage than the wire in the protected circuit. The wire is covered with a thick non-flammable insulation. An overload causes the link to heat and the insulation to blister. If the overload remains, the link will melt, causing an open circuit. The links are color coded for wire size as follows:

COLOR CODE	
BLUE	20 GA
BROWN OR RED	18 GA
BLACK OR ORANGE	16 GA
GREEN	14 GA

When replacing, make tight crimp joints or hot solder joints for good connections.

DIODES



Diodes are electrical devices that permit current to flow in one direction only. The current flows in the direction indicated by the arrow.

12 CHARGE/POWER DISTRIBUTION

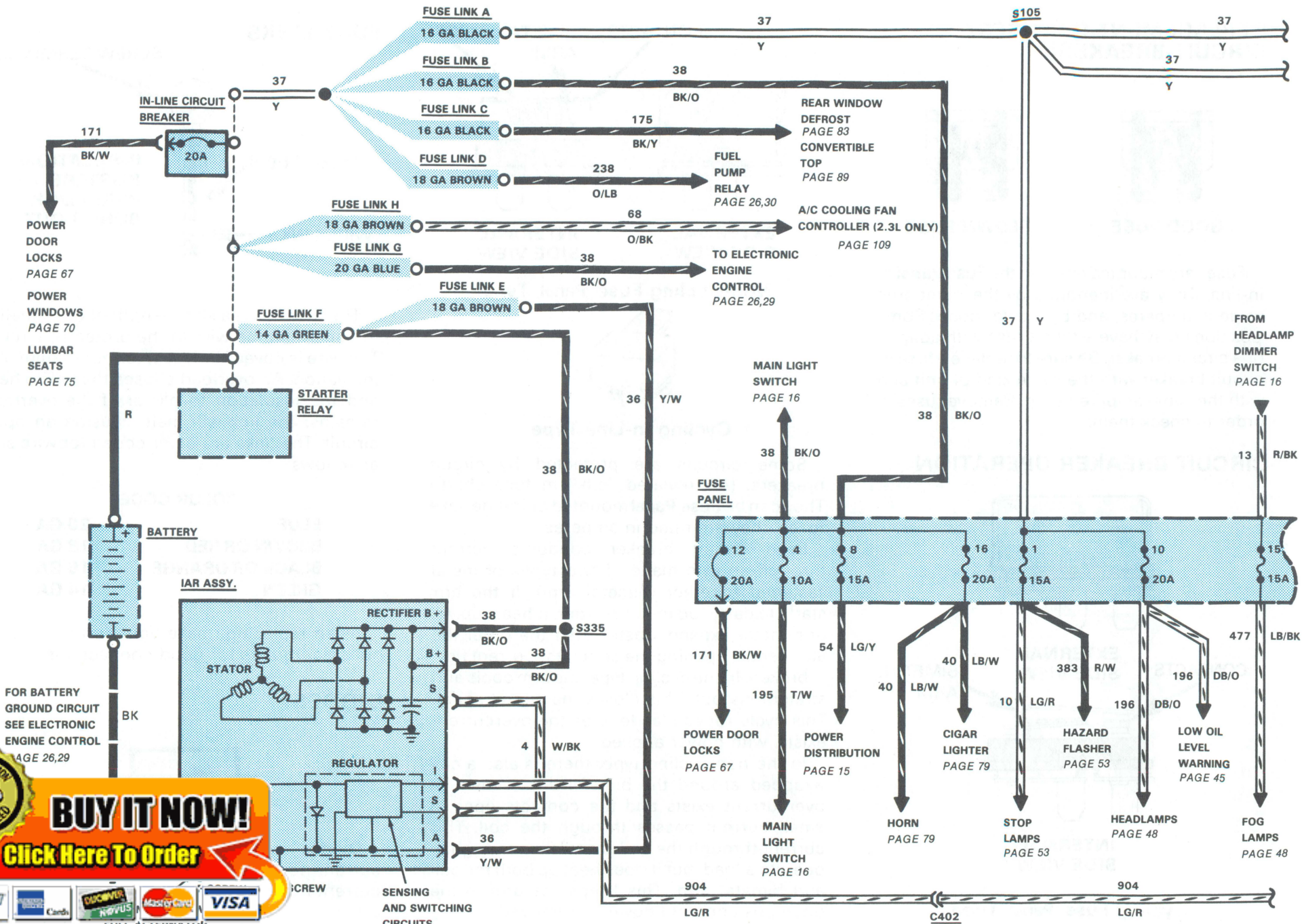

100% SATISFACTION GUARANTEED

BUY IT NOW!

Click Here To Order

ICREW SENSING AND SWITCHING CIRCUITS FULL ALTERNATOR

PayPal, Discover, MasterCard, VISA

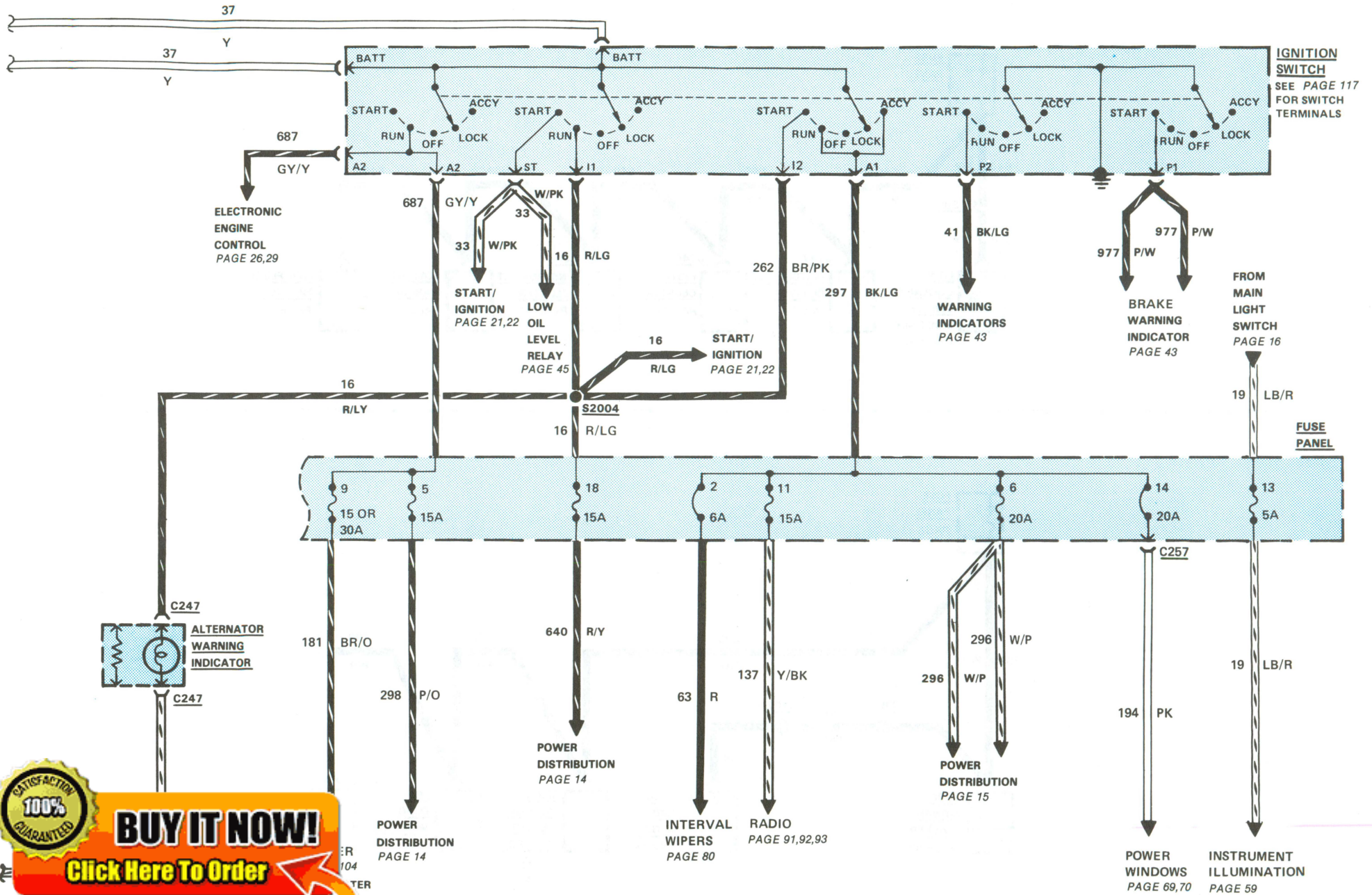

100% SATISFACTION GUARANTEED

BUY IT NOW!

Click Here To Order

TER 104
TER

PAGE

PayPal American Express Discover Novus MasterCard VISA

14 POWER DISTRIBUTION (FUSE 18, FUSE 5)

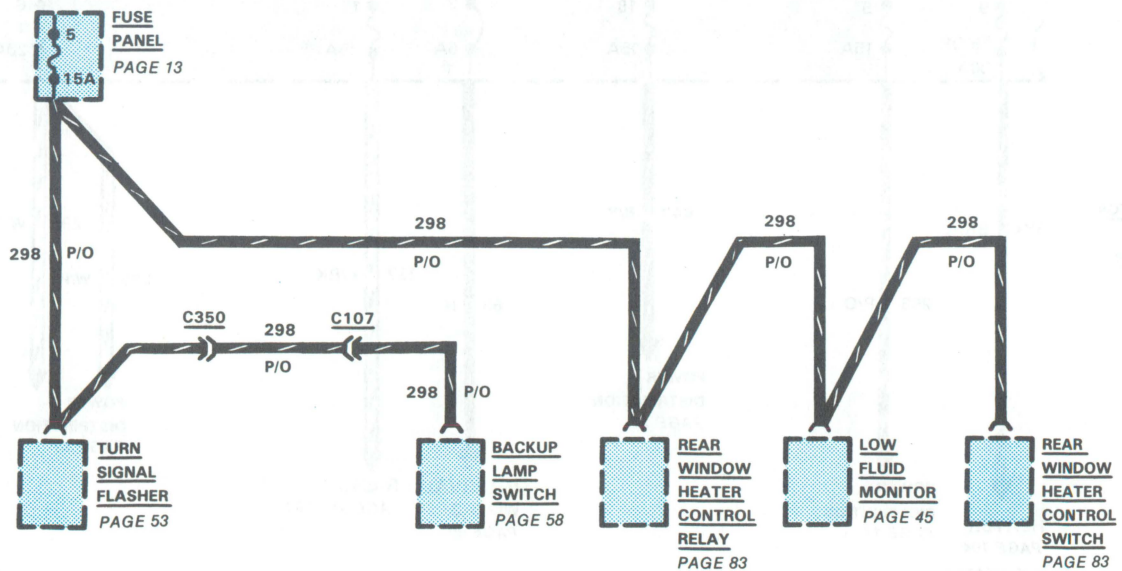
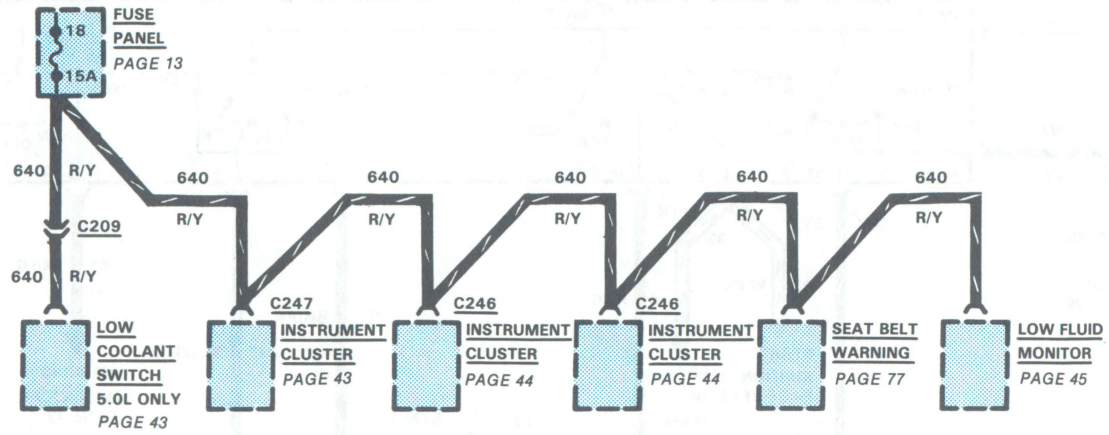

100% SATISFACTION GUARANTEED

BUY IT NOW!

Click Here To Order

PayPal | American Express | Discover | MasterCard | VISA

16 CHARGE/POWER DISTRIBUTION (MAIN LIGHT SWITCH)

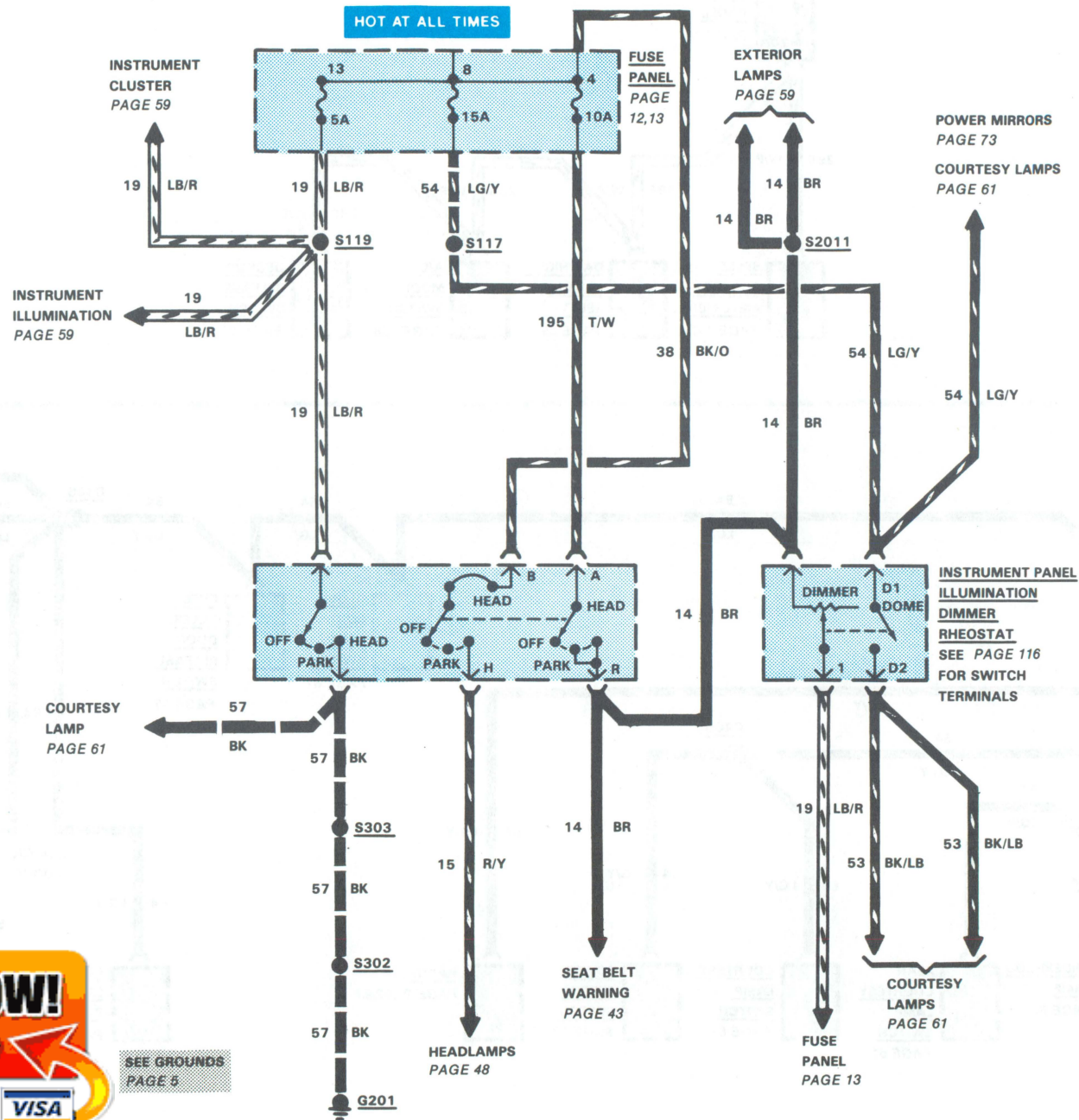

SEE GROUNDS
PAGE 5

100% SATISFACTION GUARANTEED

BUY IT NOW!

Click Here To Order

PayPal, American Express, Discover, MasterCard, VISA

HOW THE CIRCUIT WORKS

The **Battery, Alternator and Voltage Regulator** make up the **Charging System**.

With Alternator Warning Indicator

With the **Ignition Switch** in RUN, **Battery** current flows into the **Voltage Regulator** at terminal I and to ground through the solid-state regulator circuits. If the electronic control measures a low voltage at regulator terminal A it closes the field switch. This applies **Battery** voltage to the field.

With current in the field and the rotor turning, the **Alternator** stator produces an AC voltage. This is converted to DC by the rectifier assembly and is fed to terminal B (to **Battery**) and terminal S (stator). (Voltage at S is one-half voltage at B).

A pre-set voltage at terminal S operates the electronic control to open the indicator switch which removes ground from the **Alternator Warning Indicator** (through the heated windshield control modules, on models so equipped).

The **Alternator** output is controlled by the current in the field. The average voltage on the field depends on the percentage of time the field switch is closed. The electronic control closes the field switch when the voltage at A is low, and opens the switch when the voltage at A is high.

The **Voltage Regulator** holds the system voltage at about 14 volts. The average **Alternator** output is then any required value between zero and full current depending on conditions sensed by the **Voltage Regulator**.

COMPONENT LOCATION

		Page-Figure	Color	Terminals
Fuse Link A	At starter relay	18-3		
Fuse Link B	At starter relay	18-3		
Fuse Link C	At starter relay	18-3		
Fuse Link D	At starter relay	18-3		
Fuse Link E	LH fender apron	18-3		
Fuse Link F	At starter relay	18-3		
Fuse Link G	At starter relay	18-3		
Fuse Link H	At starter relay	18-3		
Connector C149	Near battery	18-3	BK	1
Connector C201	LH fender apron	18-3	BK	8
Connector C209	LH fender apron	18-3	BK	8
Connector C247	At instrument cluster	114-1	GY	14
Connector C355	LH fender apron	18-3	BK	2
Connector C402	Near starter motor relay	18-3	BK	4
Connector C403	Near cooling fan controller	18-3	GY	8
Connector C430	Near wiper motor	18-3	BR	1
Ground G101	At battery			
Ground G201	LH fender apron			
Splice S105	Near T/O to headlamp dimmer switch			
Splice S335	Near IAR Assembly			
Splice S2004	Near EGR valve position sensor			

- Check **Battery** terminals and cable clamps.
- Check for clean and tight connection on **Alternator, Regulator, and Starter Relay** and alternator output control relay.

- Refer to Shop Manual Section 31-01, Charging System Diagnosis.

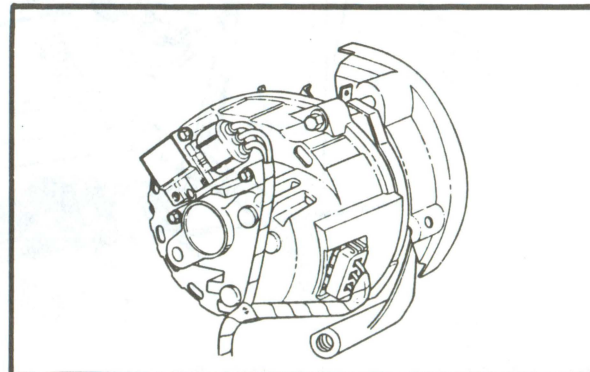

Figure 1- Integral Alternator/Regulator (5.0L)

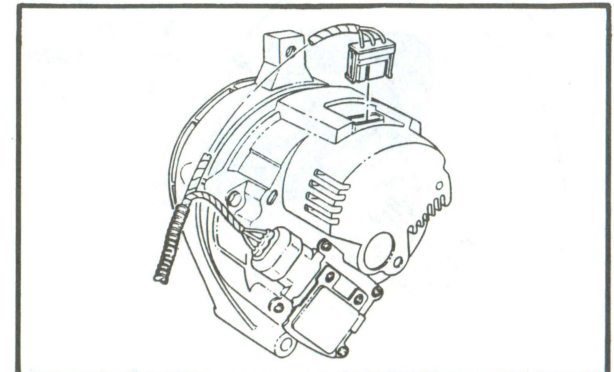

Figure 2- Alternator (2.3L)

SHOOTING HINTS

100% SATISFACTION GUARANTEED

BUY IT NOW!

Click Here To Order

PayPal, American Express, Discover, MasterCard, VISA

ar... complaints
dic... ing In-

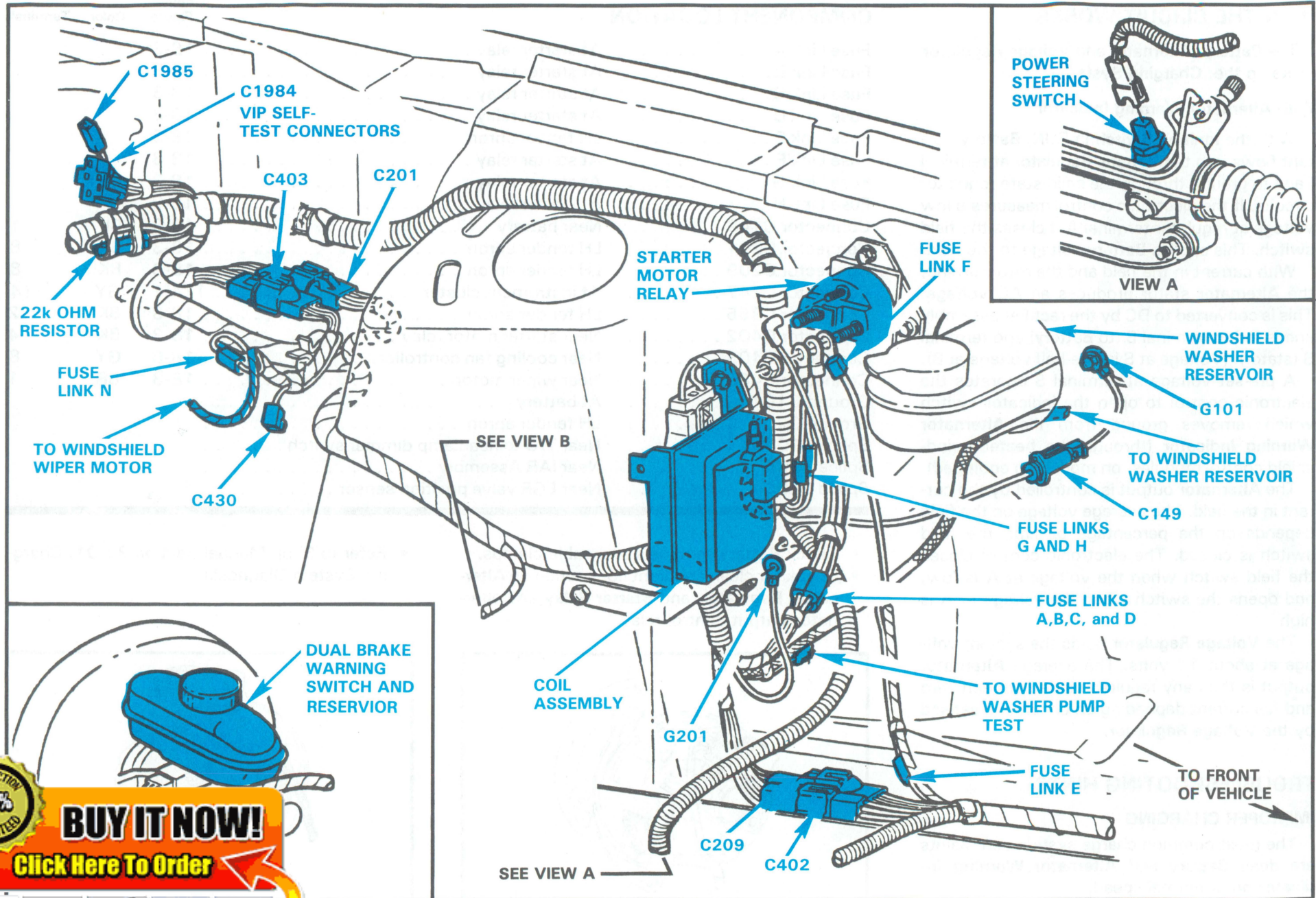

100% SATISFACTION GUARANTEED

BUY IT NOW!

[Click Here To Order](#)

Figure 3- LH Fender Apron (2.3L)

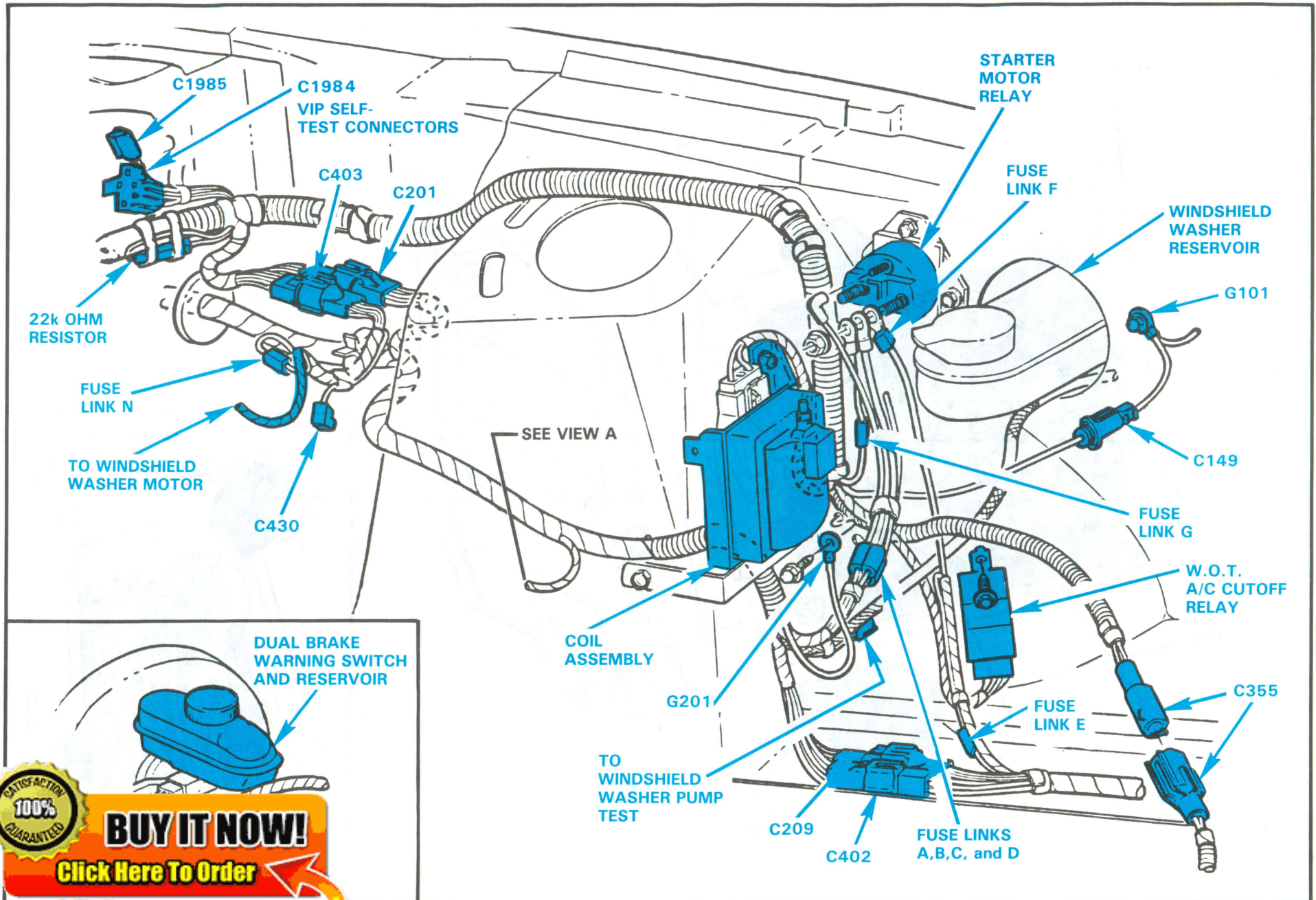
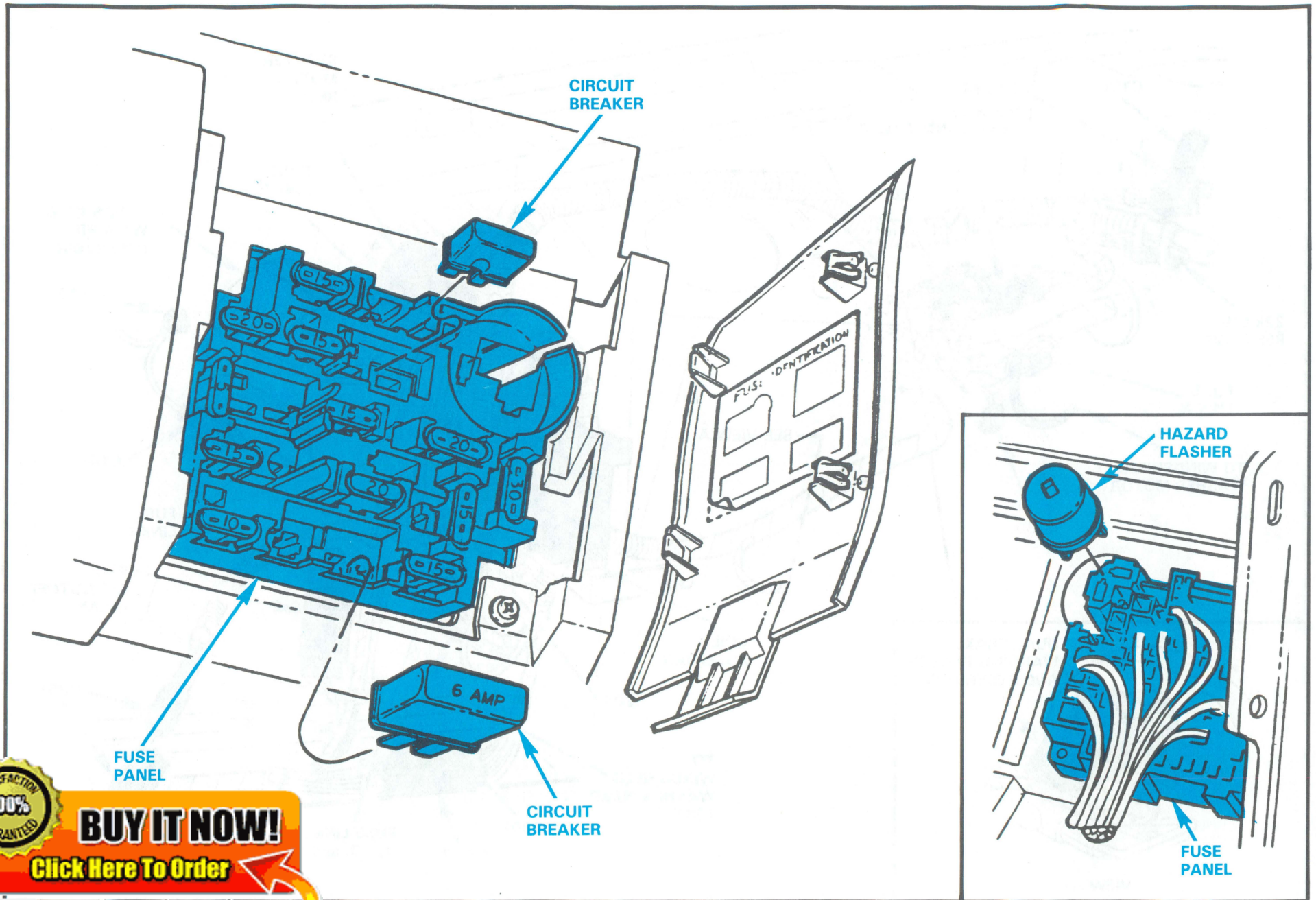

Figure 4- LH Fender Apron (5.0L)

100% SATISFACTION GUARANTEED

BUY IT NOW!

Click Here To Order



100% SATISFACTION GUARANTEED

BUY IT NOW!

Click Here To Order

PayPal American Express Cards Discover Novus MasterCard VISA

Figure 5- Circuit Breaker and Hazard Warning Flasher

TERMINAL LOCATIONS

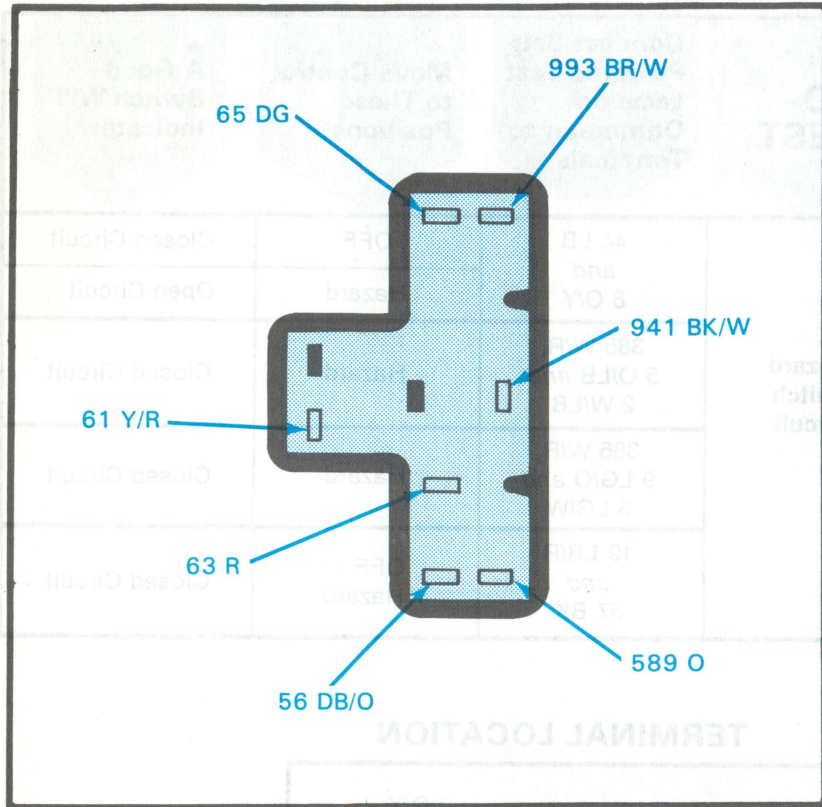

SCHEMATIC

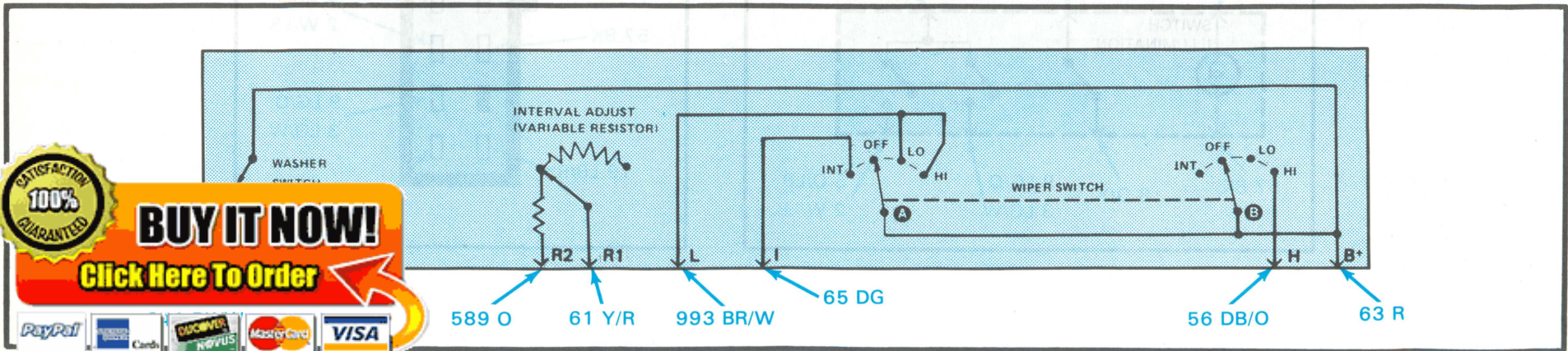

INTERVAL WIPER/WASHER SWITCH COMPONENT TESTING PROCEDURE

TO TEST	Connect Self Powered Test Lamp or Ohmmeter to Terminals	Move Switch to These Positions	A Good Switch Will Indicate
Washer Switch Circuit	941 BK/W (W) and 63 R (B+)	Pull Washer Knob	Closed Circuit
		Release Washer Lever	Open Circuit
Wiper Switch Circuit	63 R (B+) and 65 DG (I)	Wiper Switch to INT position ..	Closed Circuit
		All other positions	Open Circuit
		Wiper Switch to Lo position ..	Closed Circuit
Wiper Switch to Hi position ..	Closed Circuit		
Interval Adjust	61 Y/R (R1) and 589 O (R2)	Wiper Switch to Hi position ..	Closed Circuit
		All other positions	Open Circuit
		Rotate Control Clockwise	Ohmmeter will indicate smoothly increasing resistance from 420/880 Ohms minimum to 7000/13,000 Ohms maximum.

100% SATISFACTION GUARANTEED

BUY IT NOW!

Click Here To Order

PayPal, Discover, MasterCard, VISA

COMPONENT TESTING PROCEDURE

TO TEST	Connect Self Powered Test Lamp or Ohmmeter to Terminals	Move Control to These Positions	A Good Switch Will Indicate
Turn Switch Circuit	8 O/Y and 9 LG/O	Turn Switch to Turn Left	Closed Circuit
	8 O/Y and 3 LG/W	Turn Switch to Turn Left	Closed Circuit
	8 O/Y and 5 O/LB	Turn Switch to Turn Right	Closed Circuit
	8 O/Y and 2 W/LB	Turn Switch to Turn Right	Closed Circuit

COMPONENT TESTING PROCEDURE

TO TEST	Connect Self Powered Test Lamp or Ohmmeter to Terminals	Move Control to These Positions	A Good Switch Will Indicate
Hazard Switch Circuit	44 LB and 8 O/Y	OFF	Closed Circuit
		Hazard	Open Circuit
	385 W/R, 5 O/LB and 2 W/LB	Hazard	Closed Circuit
		385 W/R, 9 LG/O and 3 LG/W	Hazard
19 LB/R and 57 BK	OFF or Hazard	Closed Circuit	

SCHEMATIC

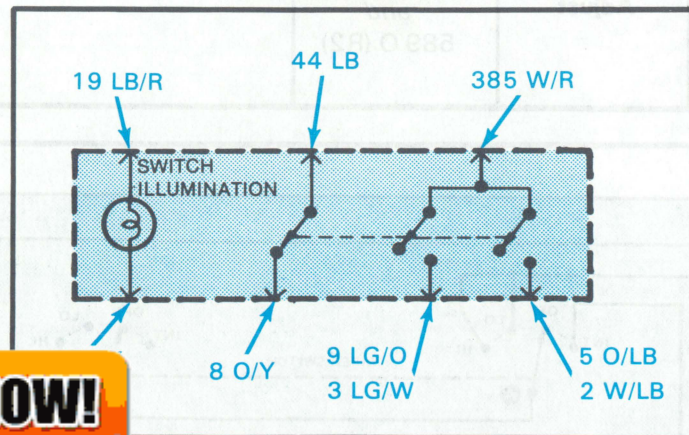

TERMINAL LOCATION

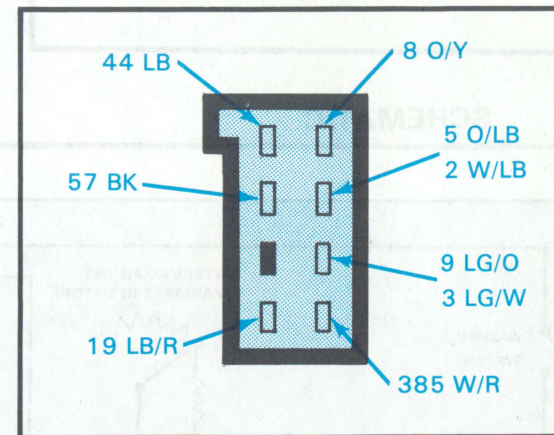

100% SATISFACTION GUARANTEED

BUY IT NOW!

Click Here To Order

COMPONENT TESTING PROCEDURE

TERMINAL LOCATIONS

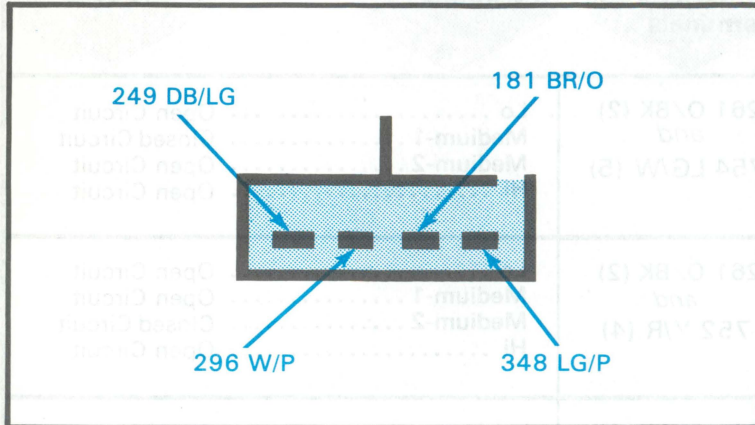

TO TEST	Connect Self Powered Test Lamp or Ohmmeter to Terminals	Move Switch to These Positions	A Good Switch Will Indicate
A/C Clutch Switch Circuit	296 W/P <i>and</i> 348 LG/P	OFF A/C Max A/C Normal Vent Hi/Lo Heat Defrost	Open Circuit Closed Circuit Closed Circuit Open Circuit Open Circuit Open Circuit Closed Circuit
Blower Motor Control Switch Circuit	181 BR/O <i>and</i> 249 DB/LG	OFF..... All other positions	Open Circuit Closed Circuit

SCHEMATIC

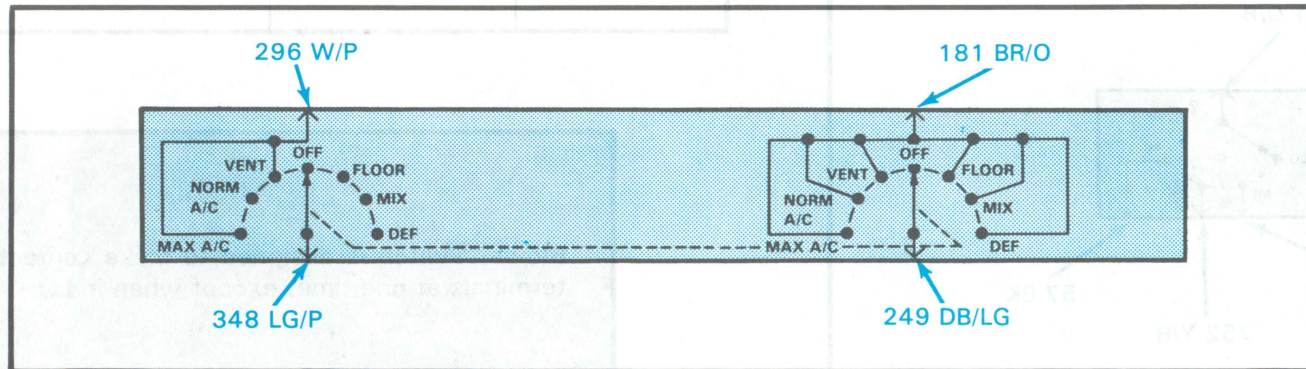

100% SATISFACTION GUARANTEED

BUY IT NOW!

Click Here To Order

122 COMPONENT TESTING: A/C BLOWER SWITCH

TERMINAL LOCATION

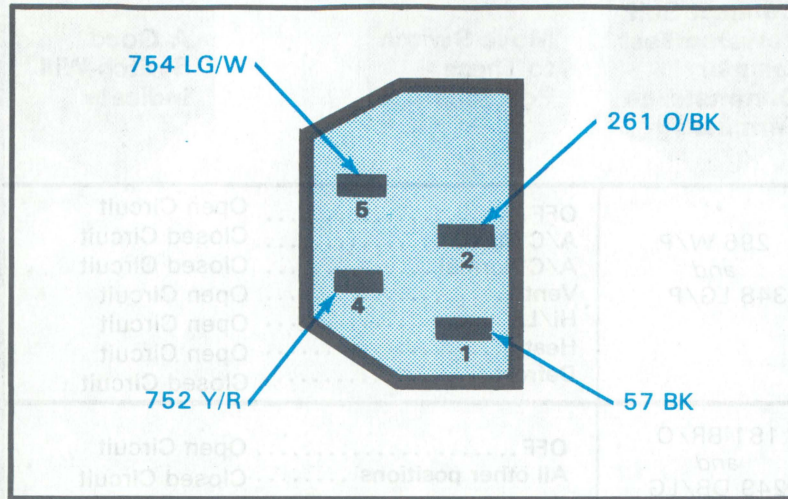

SCHEMATIC

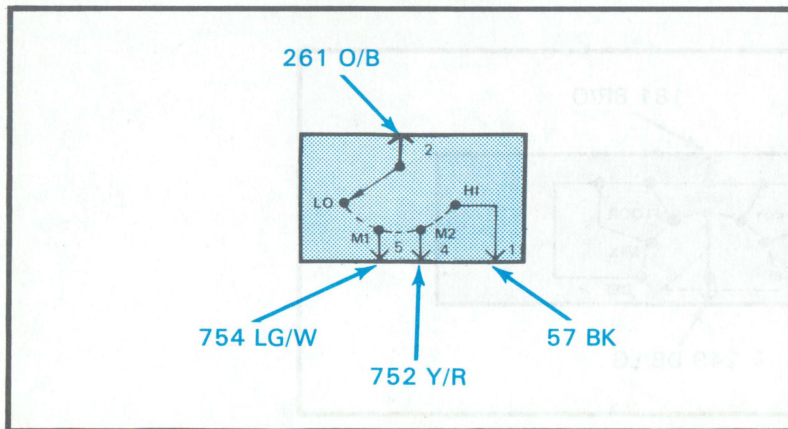

COMPONENT TESTING PROCEDURE

TO TEST	Connect Self Powered Test Lamp or Ohmmeter to Terminals	Move Control to These Positions	A Good Switch Will Indicate
Medium-Low Speed	261 O/BK (2) and 754 LG/W (5)	Lo Medium-1 Medium-2 Hi	Open Circuit Closed Circuit Open Circuit Open Circuit
Medium-High Speed	261 O/BK (2) and 752 Y/R (4)	Lo Medium-1 Medium-2 Hi	Open Circuit Open Circuit Closed Circuit Open Circuit
High Speed	261 O/BK (2) and 57 BK (1)	Lo Medium-1 Medium-2 Hi	Open Circuit Open Circuit Open Circuit Closed Circuit

NOTE

Blower Switch is designed to make contacts with two terminals at one time, except when in LO.

100% SATISFACTION GUARANTEED

BUY IT NOW!

Click Here To Order



**WE SUPPORT VOLUNTARY
TECHNICIAN CERTIFICATION**



**Ford Parts and Service Division
Training and Publications Department**

100% SATISFACTION GUARANTEED

BUY IT NOW!

Click Here To Order 

PayPal American Express Discover PLUS MasterCard VISA

AUG. 1986

