

1987 BRONCO/F150-350

DEMO

This DEMO contains only a few pages of the entire manual/product.

Not all Bookmarks work on the Demo, but they do on the full version.

Features:

- Searchable text
- Printable pages
- Bookmarked for easy navigation
- High Resolution images
- Zoom to see exact details
- Money back Guarantee
- Available on USB and eBook download

1987 BRONCO/ F150-350

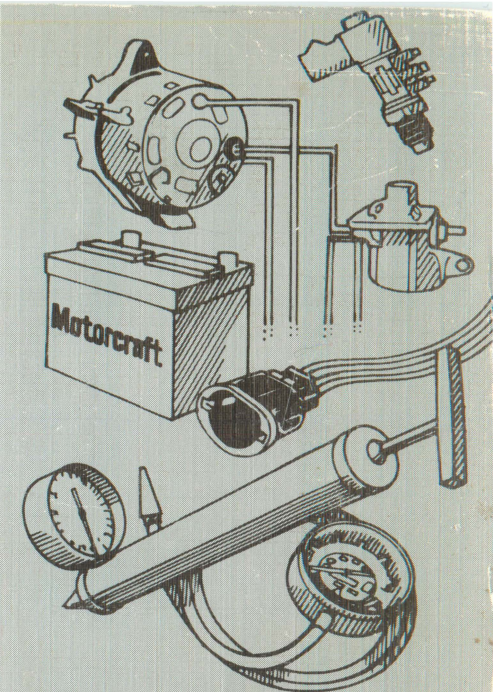

Electrical & Vacuum Trouble-Shooting Manual

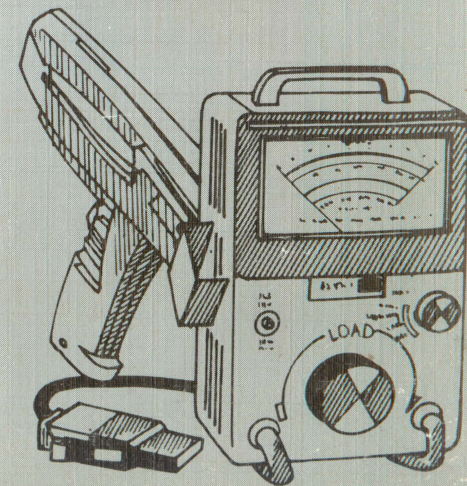

BUY IT NOW!

Click Here To Order



License #84356800

Copyright © 2023, Forel Publishing Company, LLC, Woodbridge, Virginia

All Rights Reserved. No part of this book may be used or reproduced in any manner whatsoever without written permission of Forel Publishing Company, LLC. For information write to Forel Publishing Company, LLC, Woodbridge, VA 22192

**1987 Bronco/F150-F350 Electrical & Vacuum Trouble-
Shooting Manual (EVTM)
EAN: 978-1-60371-410-5
ISBN: 1-60371-410-3**

Forel Publishing Company, LLC
Woodbridge, VA 22192
Email: sales@ForelPublishing.com
<https://www.ForelPublishing.com>



This publication contains material that is reproduced and distributed under a license from Ford Motor Company. No further reproduction or distribution of the Ford Motor Company material is allowed without the express written permission of Ford Motor Company.

Note from the Publisher

This product was created from the original Ford Motor Company's publication. Every effort has been made to use the original scanned images, however, due to the condition of the material; some pages have been modified to remove imperfections.

Disclaimer

Although every effort was made to ensure the accuracy of this book, no representations or warranties of any kind are made concerning the accuracy, completeness or suitability of the information, either expressed or implied. As a result, the information contained within this book should be used as general information only. The author and Forel Publishing Company, LLC shall have neither liability nor responsibility to any person or entity with respect to any loss or damage caused, or alleged to be caused, directly or indirectly by the information contained in this book. Further, the publisher and author are not engaged in rendering legal or other professional services. If legal, mechanical, electrical, or other expert assistance is required, the professional should be sought.



How to Use This Manual	1
How to Find the Electrical Problem	2, 3
Symbols (Electrical)	4
(Vacuum)	127
How to Find the Vacuum Problem	129
Instrument Panel (Back View)	
Component Testing	
Introduction	142
Main Light Switch	142
Hazard Switch	144
Ignition Switch	143
Turn Switch	144
Windshield Wiper/Washer Switch	145
Interval Wiper/Washer Switch	146
A/C-Heater Function Selector	147
A/C-Heater Blower Switch	148
.....	
A/C-Heater	135
Anti-Lock Brakes	87
Brake Warning Indicator	83
Carburetor Circuits	45
Charge (Gasoline)	46
(Diesel)	22
Choke Heater	17
Cigar Lighter	106
Coolant Temperature	
Gage	93
Diesel Glow Plug Control	40
Electric Fuel Pump Control	101
Electronic Engine Control	49
Electronic Shift — 4 Wheel Drive	89
Four-Wheel Drive Indicator	90
Fuel Injector Cooling Fan — (4.9L Only)	60
Fuel Tank Selector/Gages (Diesel)	97
(Gasoline)	92
Instrument Panel (Gasoline)	19
(Diesel)	24

Gages (Diesel)	97
(Gasoline)	92
Grounds	5
Heater	134
Horn	106
Ignition	27
Instrument Illumination	80
Lamps On Warning	76
Lamps	
Backup	74
Body Marker	66
Cargo	74
Dome	76
Exterior	64
Hazard	70
Headlamps	62
Instrument Illumination	80
License	65
Map	77
Marker	65
Park	65
Radio Illumination	80
Stop	70
Tail (Rear Park)	64
Trailer	66
Turn	70
Main Light Switch	80, 151
Power Distribution (Diesel)	22
(Gasoline)	18
Power Door Locks	120
Power Windows	113
Radio (Stereo) (Electronic)	123
(Stereo)	124
Rear Window Defrost	116
Seatbelt Warning	82
Speed Control	130
Start (Diesel)	40
(Gasoline)	30

Tachometer	96
Tailgate Power Window	116
Trailer	125
Vacuum Distribution	128
Warning Indicators (Diesel)	85
Warning Indicators (Gasoline)	82
Windshield Wiper/Washer	108
Windshield Wiper/Washer (Interval)	110

IMPORTANT SAFETY NOTICE

Appropriate service methods and proper repair procedures are essential for the safe, reliable operation of all motor vehicles, as well as the personal safety of the individual doing the work. This Manual provides general directions for accomplishing service and repair work with tested, effective techniques. Following them will help assure reliability.

There are numerous variations in procedures, techniques, tools, and parts for servicing vehicles, as well as in the skill of the individual doing the work. This Manual cannot possibly anticipate all such variations and provide advice or cautions as to each. Accordingly, anyone who departs from the instructions provided in this Manual must first establish that he compromises neither his personal safety nor the vehicle integrity by his choice of methods, tools or parts.

100% SATISFACTION GUARANTEED

BUY IT NOW!

Click Here To Order

PayPal American Express Discover MasterCard VISA

The purpose of this manual is to show electrical and vacuum circuits of these vehicles in a clear and simple fashion to make troubleshooting easier. With each circuit is a description of *How the Circuit Works* and some *Troubleshooting Hints*. A *Component Location* chart lists components, connectors, and grounds in that circuit. The chart includes a description of where each item is located, and references to pictures in the manual.

Wiring Diagrams give a schematic picture of when and how the circuit is powered, what the current path is to circuit components, and how the circuit is grounded. Each circuit component is named (underlined titles). Wire and connector colors are listed (standard Ford color abbreviations are used):

COLOR ABBREVIATIONS

BL	Blue	N	Natural
BK	Black	O	Orange
BR	Brown	PK	Pink
DB	Dark Blue	P	Purple
DG	Dark Green	R	Red
GR	Green	T	Tan
GY	Gray	W	White
LB	Light Blue	Y	Yellow
LG	Light Green		

Where two colors are shown for a wire, the first color is the basic color of the wire. The second color is the stripe marking. It should be noted that the use of dots and hashes for circuit identification has been eliminated. Dots may be encountered as an additional identification. The manufacturer has the same identification for the same connector.

Connector end views of switches and other components are shown to help with bench testing. The views show the harness wire colors that connect to the mating terminals. Connector colors and locations are shown in the *Component Location* chart. Two-color listings indicate separate colors for each connector half.

Components which work together are shown together. For example, all electrical components used in any circuit are shown on one diagram. The circuit breaker or fuse is shown at the top of the page. All wires, connectors, splices, switches, and motors are shown in the flow of current to ground at the bottom of the page. Notes are included which describe how switches and other components work. If a component is used in several different circuits, it is shown in several places. For example, the **Main Light Switch** is an electrical part of many circuits, and is repeated on many pages. In some cases, however, a component may seem, by its name, to belong on a page where it has no electrical connection. For example, **Radio Illumination** is electrically part of **Instrument Illumination**. Since it has no electrical connection at all with the actual **Radio** circuit, it is not shown on the **Radio** page.

Troubleshooting Hints point the technician in a general direction, but are not intended as a step-by-step procedure. Ignition troubleshooting is an exception to this. It includes a step-by-step procedure of basic quick checks to locate some of the more common **Ignition System** problems. Read the Shop Manual for more detailed repair procedures.

The **Grounds** pages show detailed views of multiple component ground points. This is useful for checking interconnections among the ground circuits of different diagrams.

Notes, Cautions, and Warnings appear in boxes on text pages and contain important **vehicle and mechanic safety** information.

Notes give added information to help complete a particular procedure. Cautions are included to prevent making an error that could damage the vehicle. Warnings highlight areas where carelessness can cause personal injury. The following list contains some general **Warnings** that should be followed when working on a vehicle.

- Always wear safety glasses for eye protection.
- Use safety stands whenever a procedure requires being under a vehicle.
- Be sure that the **Ignition Switch** is always in the OFF position, unless otherwise required by the procedure.
- Set the parking brake when working on any vehicle. An automatic transmission should be in PARK. A manual transmission should be in NEUTRAL.
- Operate the engine only in a well-ventilated area to avoid the danger of carbon monoxide.
- Keep away from moving parts when the engine is running, especially the fan and belts.
- To prevent serious burns, avoid contact with hot metal parts such as the radiator, exhaust manifold, tail pipe, catalytic converter, and muffler.
- Do not allow flame or sparks near the battery. Gases are always present in and around the battery cell. An explosion could occur.
- Do not smoke.
- To avoid injury, always remove rings, watches, loose hanging jewelry, and loose clothing.

100% SATISFACTION GUARANTEED

BUY IT NOW!

Click Here To Order

2 HOW TO FIND THE ELECTRICAL PROBLEM

TROUBLESHOOTING STEPS

These six steps present an orderly method of troubleshooting:

Step 1. Verify the problem.

- Operate the complete system and see all symptoms for yourself in order to:
 - check the accuracy and completeness of the customer's complaint.
 - learn more that might give a clue to the nature and location of the problem.

Step 2. Narrow the problem.

- Using this manual, narrow down the possible causes and locations of the problem in order to more quickly find the exact cause.
- Read the description of *How the Circuit Works* and study the wiring diagram. You should then know enough about the circuit operation to figure out where to check for this trouble.

Step 3. Test the cause.

- Use electrical test procedures to find the specific cause of the symptoms.
- *Troubleshooting Hints* will give some helpful ideas.
- The *Component Location* charts and the pictures will help you find components, grounds, and connectors.

Step 4. Verify the cause.

- Confirm the fact that you have found the correct cause through operating the parts of the circuit you think are good.

Step 5. Make the repair.

- Repair or replace the faulty component.

Step 6. Verify the repair.

and check symptoms, any new

special test See the

Shop Manual and other service books for details. You will find the circuits in this manual to be helpful with these special tests.

TROUBLESHOOTING TOOLS

JUMPER WIRE

This is a test lead used to connect two points of a circuit. A **Jumper Wire** can complete a circuit by bypassing an open.

Uses: Bypassing Switches or Open Circuits

WARNING

Never use a jumper wire across loads (motors, etc.) connected between hot and ground. This direct battery short may cause injury or fire.

VOLTMETER

A DC **Voltmeter** measures circuit voltage. Connect negative (- or black) lead to ground, and positive (+ or red) lead to voltage measuring point.

OHMMETER

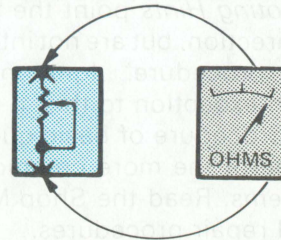

Figure 1— Resistance Check

An **Ohmmeter** shows the resistance between two connected points (Figure 1).

TEST LIGHT

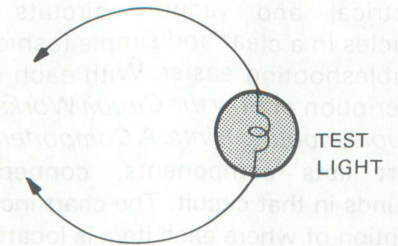

Figure 2— Test Light

A **Test Light** is a 12-volt bulb with two test leads (Figure 2).

Uses: Voltage Check. Short Check

SELF-POWERED TEST LIGHT

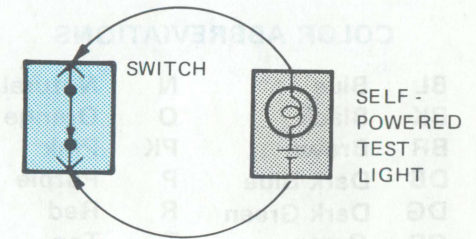

Figure 3— Continuity Check

The **Self-Powered Test Light** is a bulb, battery and set of test leads wired in series (Figure 3). When connected to two points of a continuous circuit, the bulb glows.

Uses: Continuity Check. Ground Check

CAUTION

When using a self-powered test light or ohmmeter, be sure power is off in circuit during testing. Hot circuits can cause equipment damage and false readings.

100% SATISFACTION GUARANTEED

BUY IT NOW!

Click Here To Order

PayPal American Express Discover MasterCard VISA

TROUBLESHOOTING CHECKS

SWITCH CIRCUIT CHECK

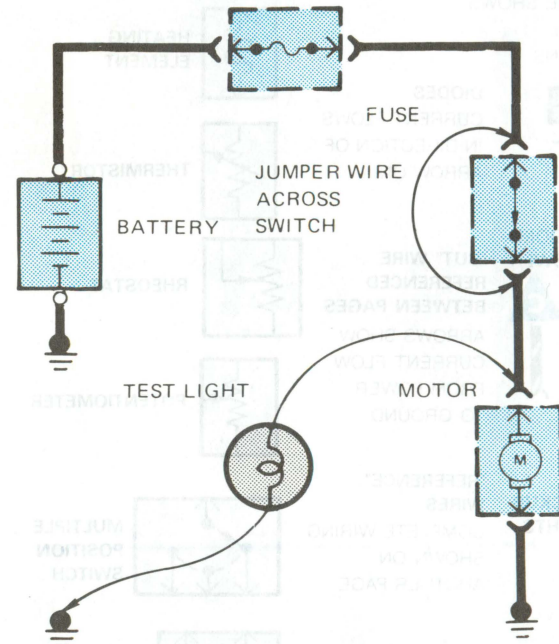

Figure 4—Switch Circuit Check and Voltage Check

In a bad circuit with a switch in series with the load, jumper the terminals of the switch to power the load. If jumping the terminals powers the circuit, the switch is bad (Figure 4).

CONTINUITY CHECK (Locating open circuits)

With power off, connect one lead of **Self-Powered Test Light** or **Ohmmeter** to each end of circuit (Figure 3). Light will glow if circuit is closed. Switches and fuses can be checked in same way.

SHORT CHECK (short to ground)

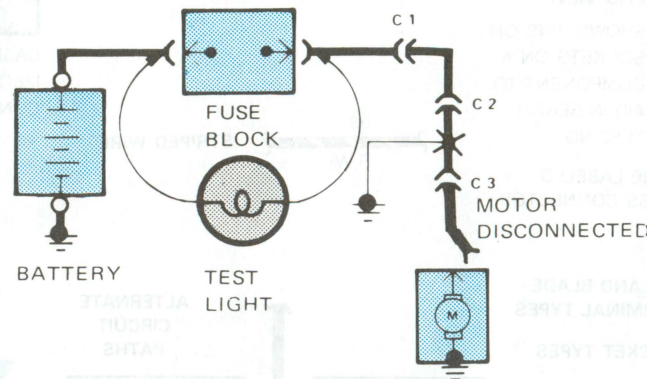

Figure 5—Short Check

A fuse that repeatedly blows is usually caused by a short to ground. It's important to be able to locate such a short quickly (Figure 5).

- 1) Turn off everything powered through the fuse.
- 2) Disconnect other loads powered through the fuse:
 - Motors: disconnect motor connector.
 - Lights: remove bulbs.
- 3) Turn **Ignition Switch** to RUN (if necessary) to power fuse.
- 4) Connect one **Test Light** lead to hot end of blown fuse. Connect other lead to ground. Bulb should glow showing power to fuse. *(This step is just a check to be sure you have power to the circuit.)*
- 5) Disconnect the **Test Light** lead from ground and reconnect it to the load side of the fuse.
 - If the **Test Light** is off, the short is in the disconnected equipment.
 - If the **Test Light** goes on, the short is in the wiring. You must find the short by disconnecting the circuit connectors one at a time until the **Test Light** goes out. For example: with a ground at X, the bulb goes out when C1 or C2 is disconnected, but stays on after disconnecting C3. This

means the ground is between C2 and C3.

"GOOD GROUND" CHECK

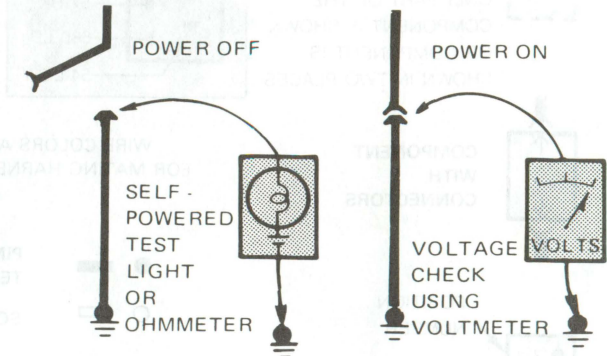

Figure 6—Grounds Checks

Turn on power to circuit. Perform Voltage Check between suspected bad ground and frame. Any voltage means ground is bad.

Turn off power to circuit. Connect one lead of **Self-Powered Test Light** or **Ohmmeter** to wire in question, and the other to known ground. If bulb glows, circuit ground is OK (Figure 6).

TROUBLESHOOTING HINTS

The circuit schematics in this manual are designed to make it easy to identify common points in circuits. This knowledge can help narrow the problem to a specific area. For example, if several circuits fail at the same time, check for a common power or ground connection. (See *Power Distribution* or *Grounds*). If part of a circuit fails, check the connections between the part that works and the part that doesn't work.

For example, if low beam headlights work but high beams and the indicator light don't work, then power and ground paths must be good. Since the dimmer switch is the component which switches this power to the high beam lights and indicator, it is most likely the cause of failure.

100% SATISFACTION GUARANTEED

BUY IT NOW!

Click Here To Order

PayPal American Express Discover Novus MasterCard VISA

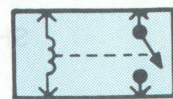
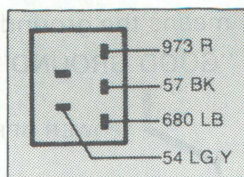
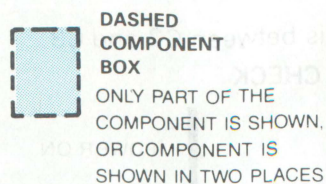

DASHED LINE SHOWS MECHANICAL CONNECTIONS



CURRENT FLOWS IN DIRECTION OF ARROW ONLY

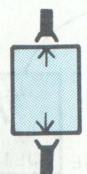
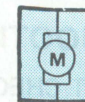

COMPONENT WITH CONNECTORS

WIRE COLORS ARE LABELED FOR MATING HARNESS CONNECTOR

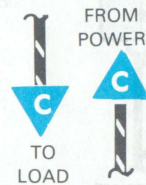
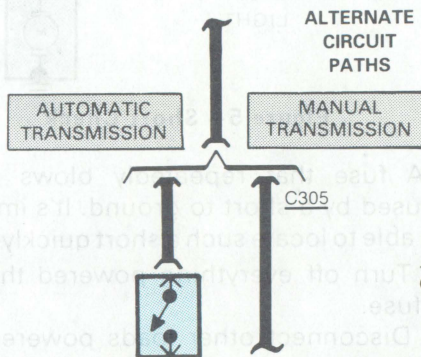
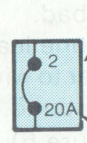
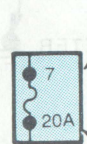

"CUT" WIRE REFERENCED BETWEEN PAGES
ARROWS SHOW CURRENT FLOW FROM POWER TO GROUND

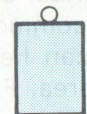

SCREW TERMINAL ON COMPONENT



SPLICE OR CRIMP CONNECTION
MOST ARE BUILT INTO HARNESS AND ARE NOT ACCESSIBLE

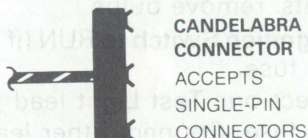

JUNCTION BLOCK

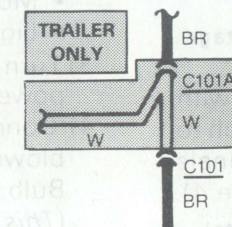

OPTIONAL WIRING
BR WIRES (INCLUDING C101) ARE ON ALL VEHICLES, BUT W WIRES (INCLUDING C101A) ARE USED ONLY WITH TRAILER

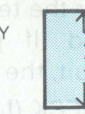

SEALED ELECTRONIC COMPONENT
ANY CIRCUITRY SHOWN INSIDE THE



SEE GROUNDS PAGE 5-15

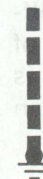

DASHED WIRE
CIRCUITRY IS NOT SHOWN IN COMPLETE DETAIL, BUT IS COMPLETE ON ANOTHER PAGE

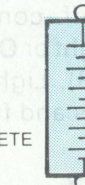

100% SATISFACTION GUARANTEED

BUY IT NOW!

Click Here To Order

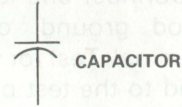
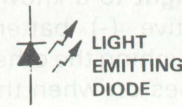
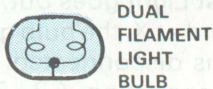

INSTRUMENT PANEL GROUND

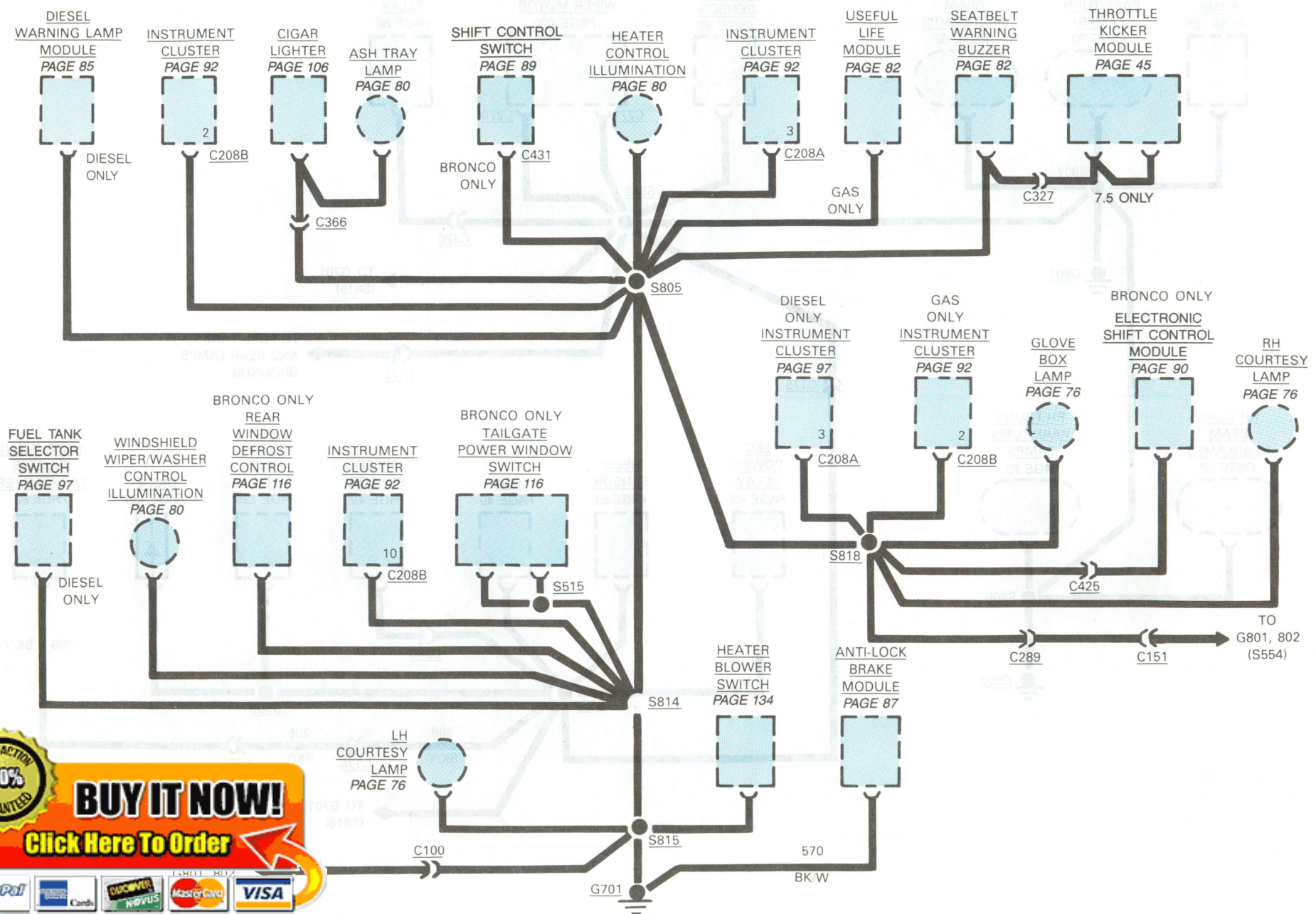

100% SATISFACTION GUARANTEED

BUY IT NOW!

Click Here To Order

PayPal | American Express | Discover | MasterCard | VISA

6 GROUNDS (G801, 802) (4.9L AND 5.0L GASOLINE)

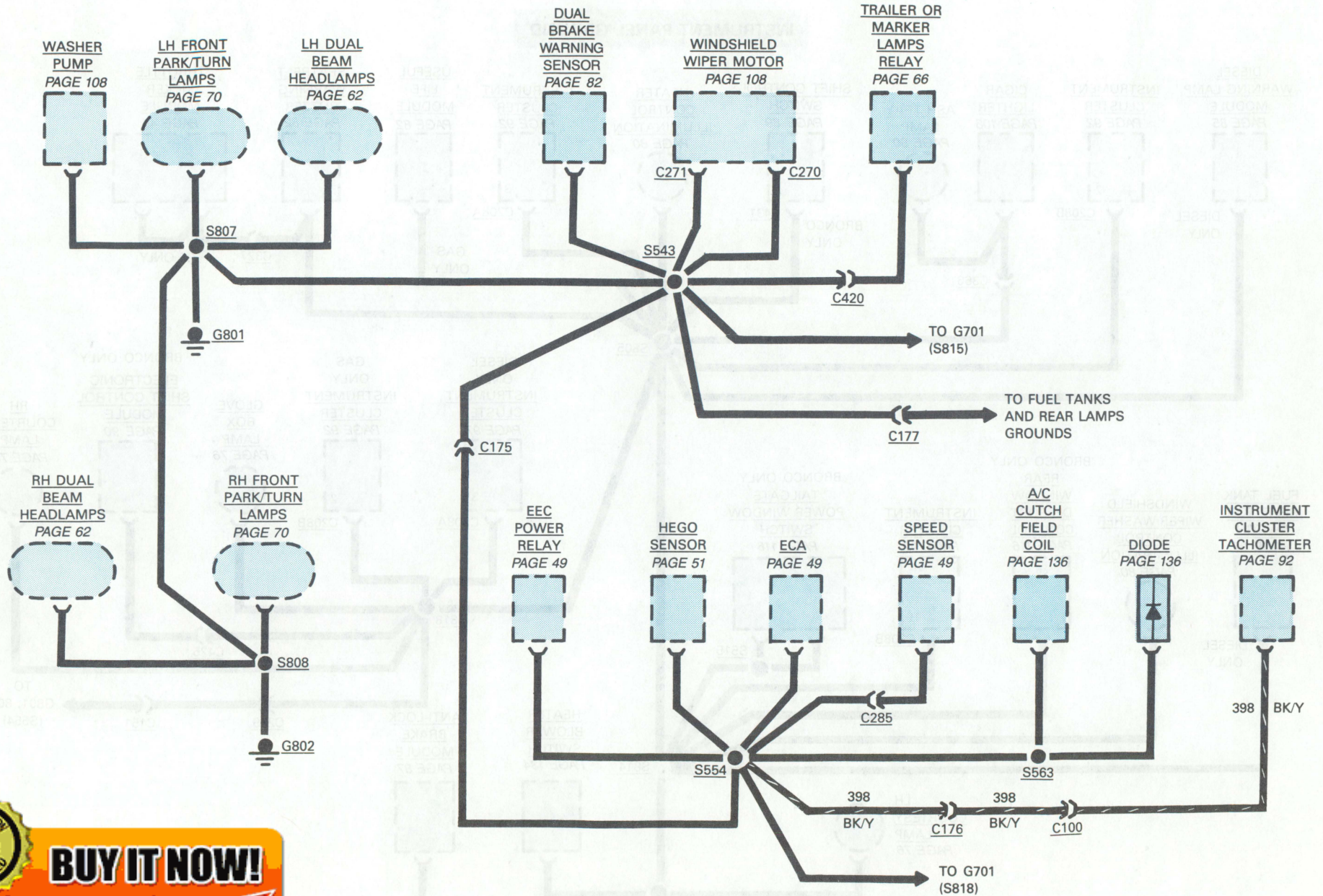

100% SATISFACTION GUARANTEED

BUY IT NOW!

Click Here To Order

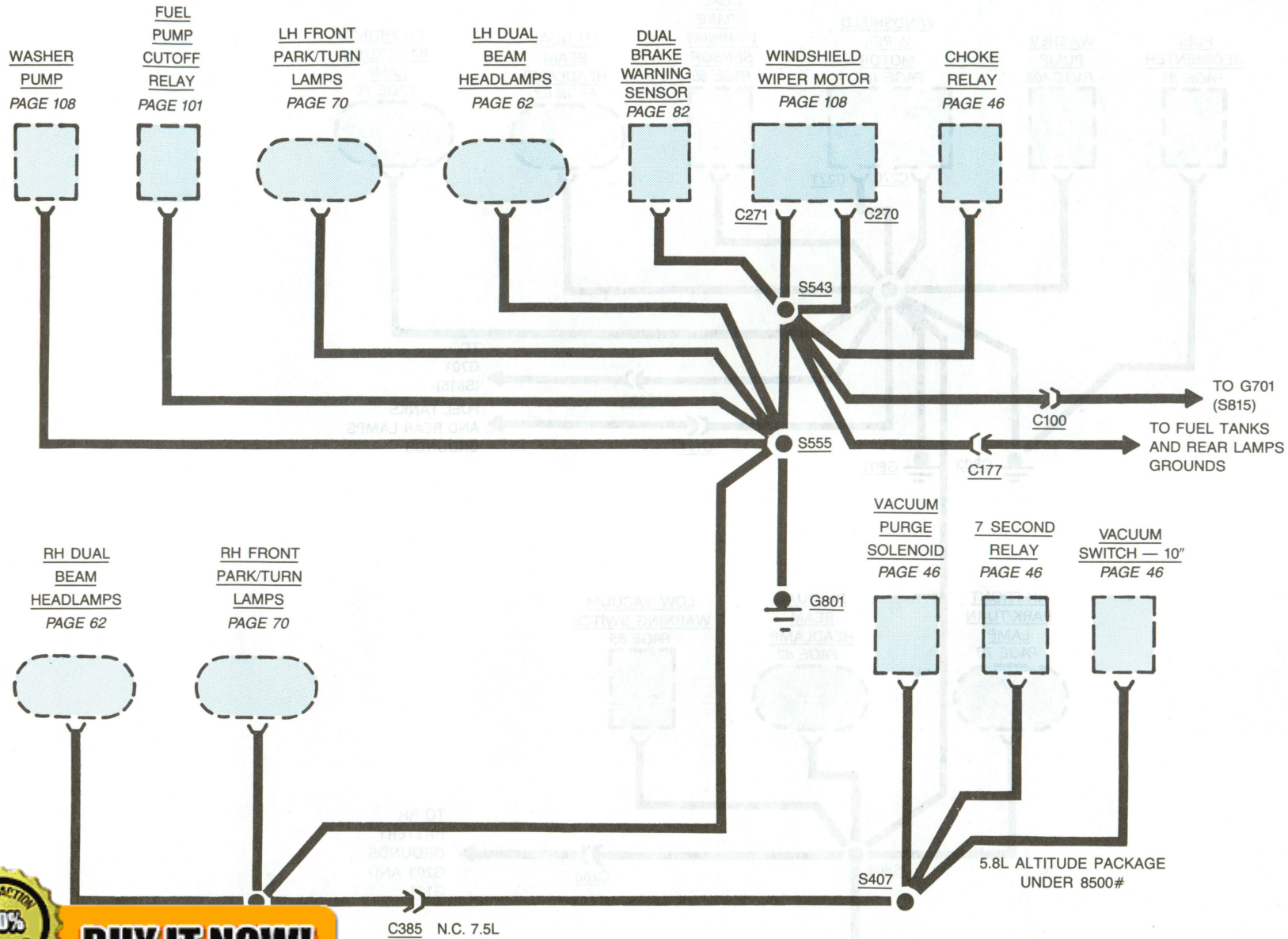

100% SATISFACTION GUARANTEED

BUY IT NOW!

Click Here To Order

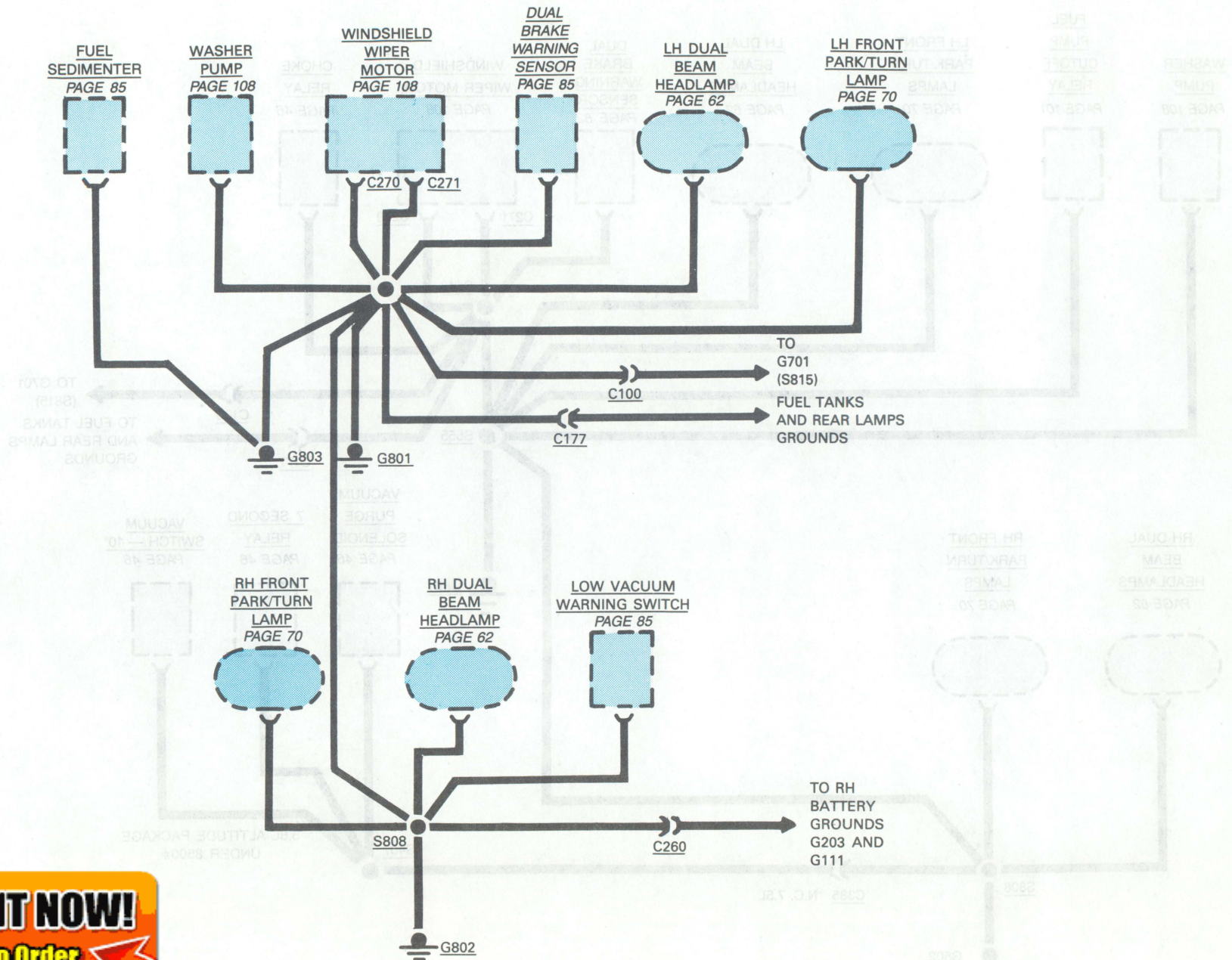

100% SATISFACTION GUARANTEED

BUY IT NOW!

Click Here To Order

PayPal | American Express | Discover | MasterCard | VISA

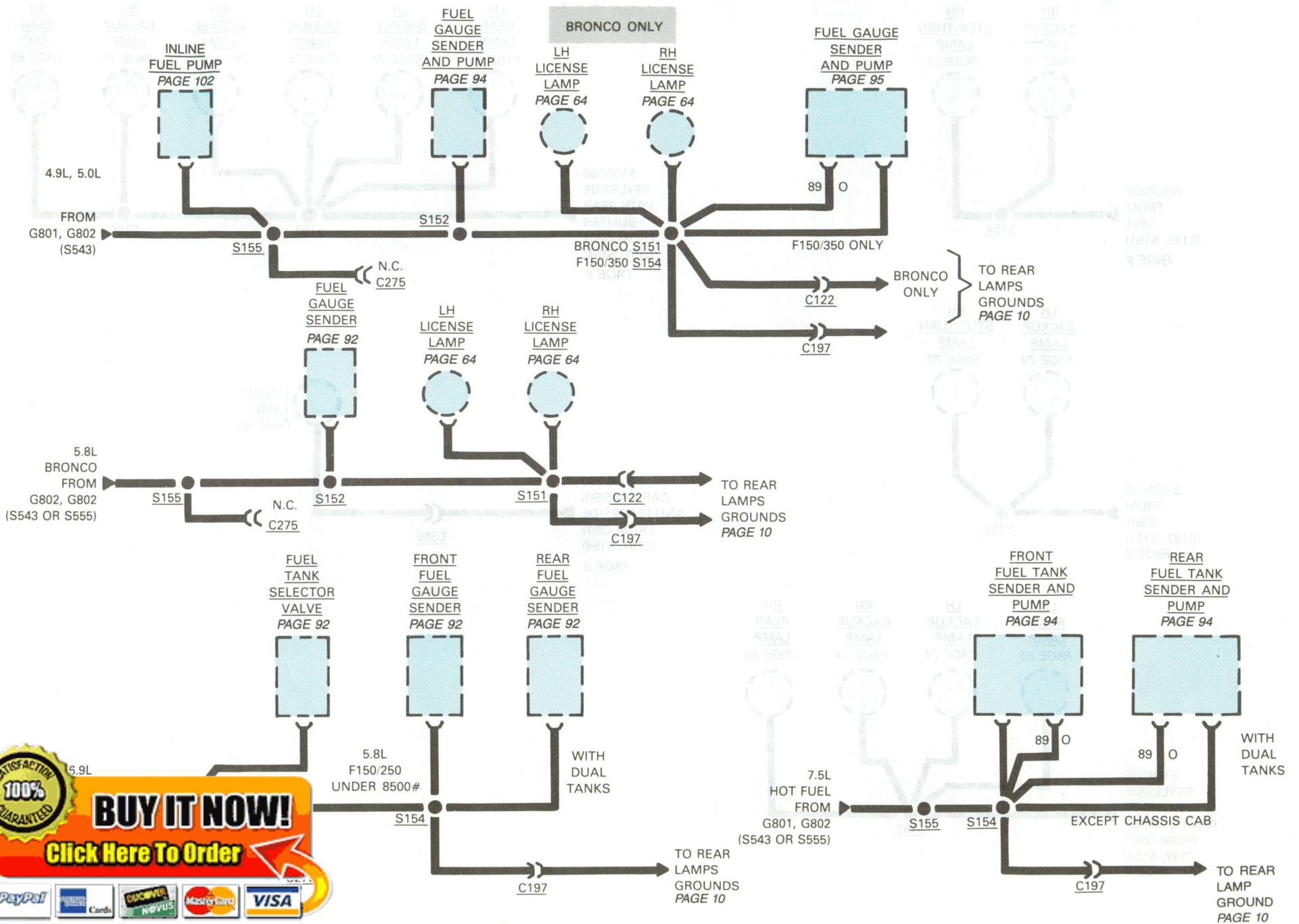

100% SATISFACTION GUARANTEED

BUY IT NOW!

Click Here To Order

PayPal American Express Discover/Novus MasterCard VISA

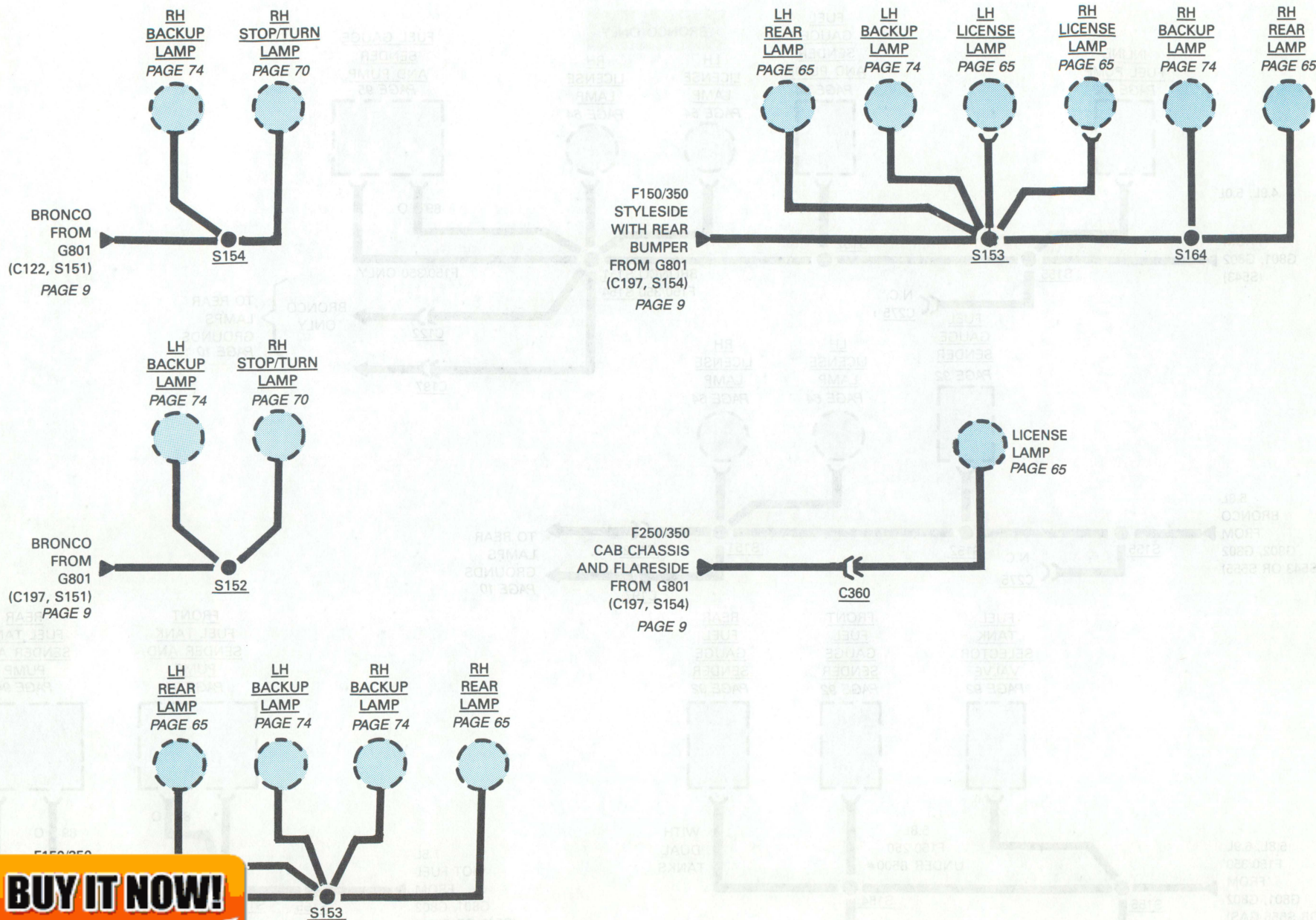

100% SATISFACTION GUARANTEED

BUY IT NOW!

Click Here To Order

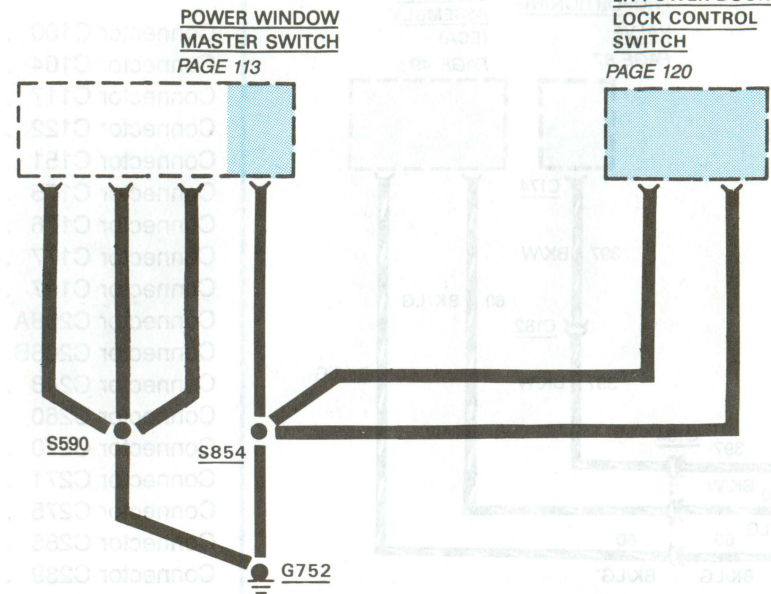
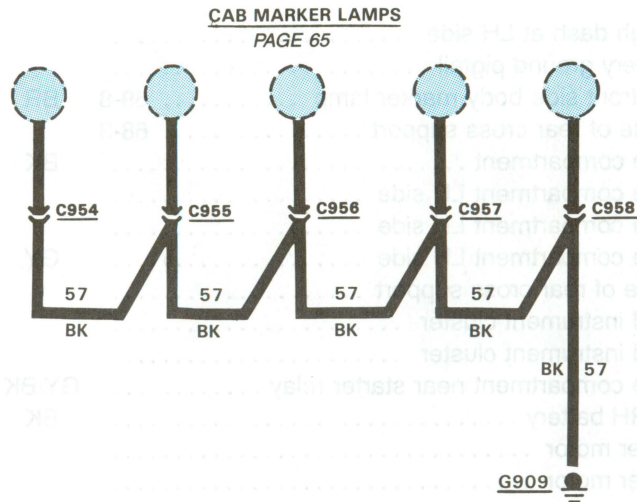

LH SIDE BODY MARKER LAMPS
PAGE 66

REAR BODY MARKER LAMPS
PAGE 66

RH SIDE BODY MARKER LAMPS
PAGE 66

MARKER OR TRAILER LAMP RELAY
PAGE 66

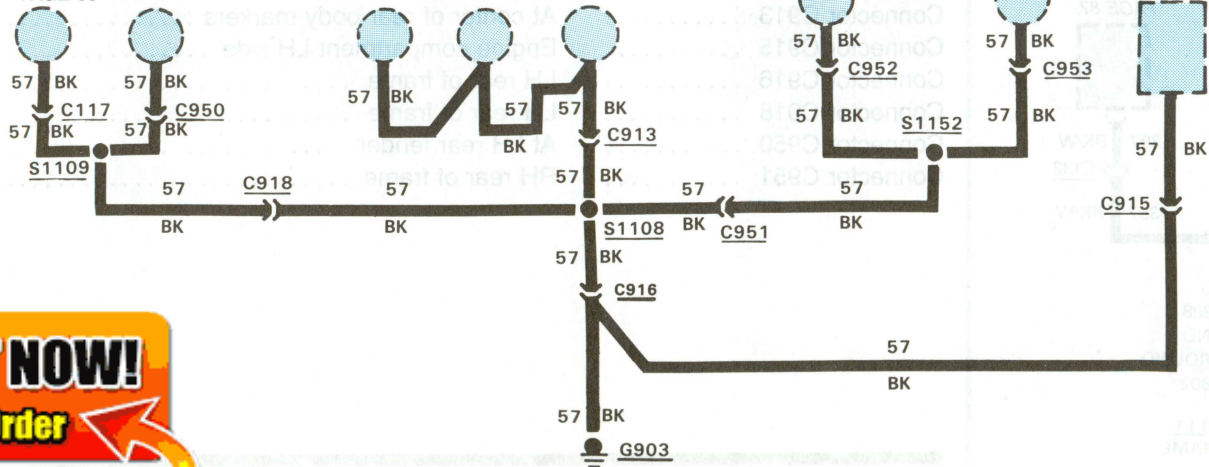

100% SATISFACTION GUARANTEED

BUY IT NOW!

Click Here To Order

PayPal American Express Discover MasterCard VISA

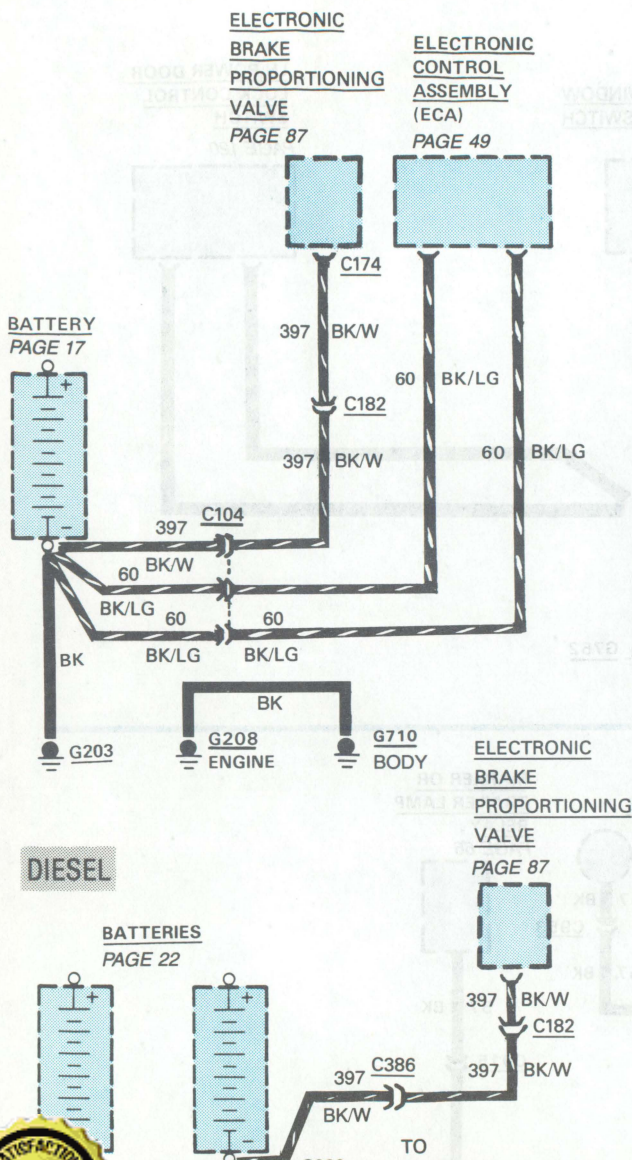

COMPONENT LOCATION

		Page-Figure	Color	Terminals
Connector C100	Through dash at LH side			53
Connector C104	At battery ground pigtail			4
Connector C117	At LH front side body marker lamp	69-8	BR	2
Connector C122	RH side of rear cross support	68-3		4
Connector C151	Engine compartment		BK	2
Connector C175	Engine compartment LH side			10
Connector C176	Engine compartment LH side			8
Connector C177	Engine compartment LH side		GY	12
Connector C197	LH side of rear cross support			8
Connector C208A	Behind instrument cluster			14
Connector C208B	Behind instrument cluster			14
Connector C248	Engine compartment near starter relay		GY/BK	4
Connector C260	Near RH battery		BK	1
Connector C270	At wiper motor			3
Connector C271	At wiper motor			3
Connector C275	Engine compartment LH rear			8
Connector C285	At speed sensor		BR	2
Connector C289	RH cowl		BK	4
Connector C327	Behind LH side of I/P	48-1		3
Connector C366	Behind center of I/P		GY	3
Connector C386	Near RH battery			1
Connector C420	Engine compartment LH side		BK	4
Connector C425	RH cowl		BK	6
Connector C431	At electronic shift switch			6
Connector C913	At center of rear body markers	69-5	GY	2
Connector C915	Engine compartment LH side		BK	2
Connector C916	LH rear of frame	68-1	BK	2
Connector C918	LH rear of frame	68-1	GY	2
Connector C950	At LH rear fender	69-8	BR	2
Connector C951	RH rear of frame	69-6	BR	2

100% SATISFACTION GUARANTEED

BUY IT NOW!

Click Here To Order

PayPal | American Express | Discover | MasterCard | VISA

(Continued on next page)

HOW THE CIRCUIT WORKS

The ground circuits shown here are complete and connect several components together to screw terminal ground points. On other pages only parts of these circuits may be shown. Partial ground circuits are shown dashed on those pages.

All simple or component ground circuits are shown on the individual circuit pages and are complete on those pages.

All ground wires are **57 BK** unless otherwise noted.

COMPONENT LOCATION

(Continued from previous page)

		Page-Figure	Color	Terminals
Connector C952	At front of RH rear fender		BR	2
Connector C953	At rear of RH rear fender	69-8	BR	2
Connector C954	At front of cab roof	67-1	BR	2
Connector C955	At front of cab roof	67-1	BK	2
Connector C956	At front of cab roof	67-1	BK	2
Connector C957	At front of cab roof	67-1	BK	2
Connector C958	At front of cab roof	67-1	BK	2
Ground G111	RH frame near battery	26-2		
Ground G203	RH side of engine	21-1		
Ground G208	Near throttle position solenoid	35-2, 37-4		
Ground G210	At electronic voltage regulator			
Ground G211	Near starter motor relay			
Ground G701	Behind I/P near center			
Ground G710	LH side of dash panel			
Ground G752	In LH door	114-1		
Ground G801	LH inner fender behind headlamps			
Ground G802	RH inner fender behind headlamps			
Ground G803	At fuel sedimenter bolt			
Ground G903	At LH side of rear crossmember	68-1		
Ground G909	At lower LH cowl access hole	69-7		
Ground G1201	At front LH side of engine	26-1		
Splice S151	Near license lamp T/O			
Splice S152	Near LH backup lamp T/O			
Splice S153	Near license lamp T/O			
Splice S154	Near front fuel gage sender T/O			
Splice S155	Near electronic rear brake pressure valve T/O			
Splice S164	Near license lamp T/O			
Splice S515	Behind I/P near liftgate power window switch T/O			
Splice S543	Engine compartment near brake sensor T/O			
Splice S554	Engine compartment near speed sensor T/O			
Splice S555	Engine compartment near ignition module T/O			
Splice S563	Engine compartment near A/C compressor clutch T/O			
Splice S590	In LH door near power window switch T/O			
Splice S805	Near cigar lighter T/O			
Splice S807	Near LH headlamp T/O			
Splice S808	Near RH front park lamp T/O			



BUY IT NOW!

Click Here To Order







14 GROUNDS

Splice S814	Near W/S wiper illumination lamp T/O
Splice S815	Near G701 T/O
Splice S818	Near RH courtesy lamp T/O
Splice S854	Near LH master window switch T/O
Splice S1108	Near rear marker lamp T/O
Splice S1109	Near LH front side marker lamp T/O
Splice S1152	Near RH front side marker lamp T/O



BUY IT NOW!

Click Here To Order 







REPLACEMENT OF FUSES/ CIRCUIT BREAKERS

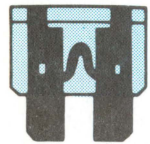

GOOD FUSE

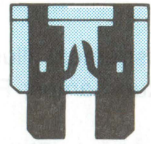

BLOWN FUSE

Fuses are mounted either in the **Fuse Panel** or in-line. They are identified by the numbered value in amperes, and by a color code. Some positions may have either a fuse with adapter or a circuit breaker. Be sure to replace a fuse or circuit breaker with the same kind of unit and with the same ampere rating. Remove fuses in order to check them.

CIRCUIT BREAKER OPERATION

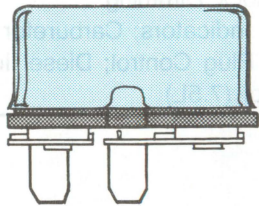

**EXTERNAL
SIDE VIEW**

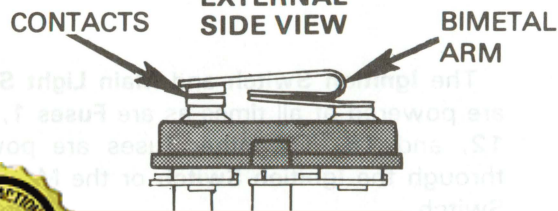

CONTACTS **BIMETAL
ARM**

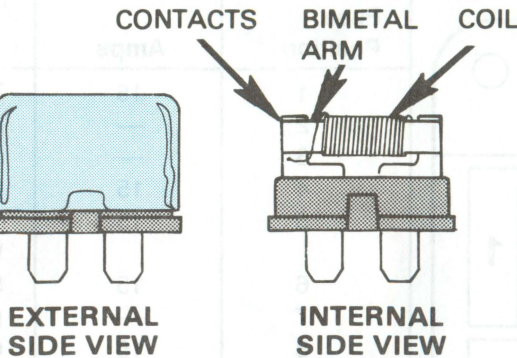

Non-Cycling Fuse Block Type

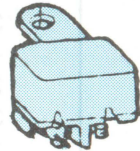

Cycling In-Line Type

Some circuits are protected by circuit breakers. (Abbreviated "c.b." in fuse chart.) They can be **Fuse Panel** mounted or in-line. Like fuses, they are rated in amperes.

Each circuit breaker conducts current through an arm made of two types of metal bonded together (bimetal arm). If the arm starts to carry too much current, it heats up. As one metal expands faster than the other, the arm bends, opening the contacts. Current flow is broken. In the cycling type, the arm cools and straightens out. This closes the circuit again. This cycle repeats as long as the overcurrent exists, with power applied.

In the non-cycling type, there is also a coil wrapped around the bimetal arm. When an overcurrent exists and the contacts open, a small current passes through the coil. This current through the coil is not large enough to

FUSE LINKS

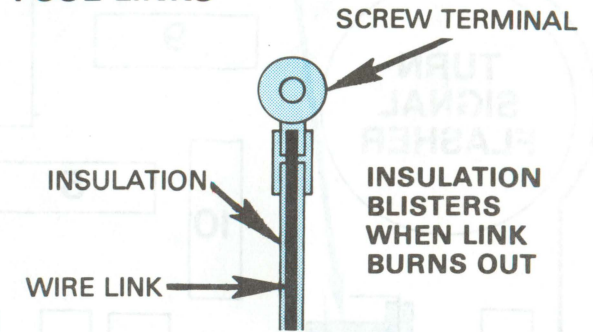

operate a load, but it does heat up both the coil and bimetal arm. This keeps the arm in the open position until power is removed.

The fuse link is a short length of wire smaller in gage than the wire in the protected circuit. The wire is covered with a thick non-flammable insulation. An overload causes the link to heat and the insulation to blister. If the overload remains, the link will melt, causing an open circuit.

When replacing, make tight crimp joints or hot solder joints for good connections.

DIODES

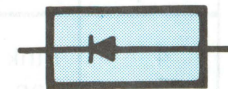

Diodes are electrical devices that permit current to flow in one direction only. The current flows in the direction indicated by the arrow.

100% SATISFACTION GUARANTEED

BUY IT NOW!

Click Here To Order

16 FUSE PANEL/CIRCUIT PROTECTION

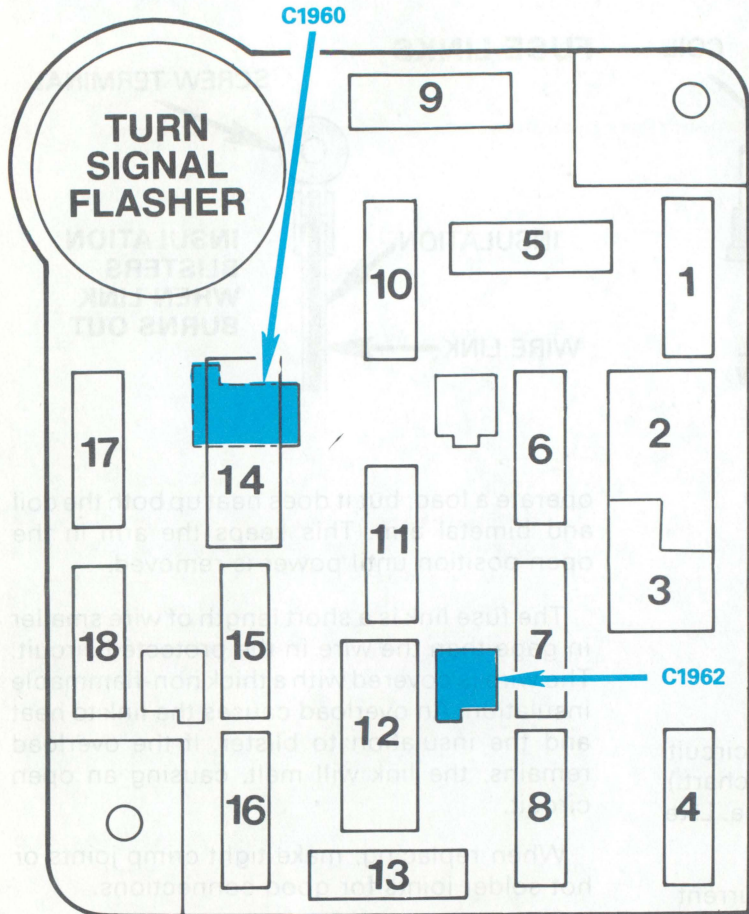

Figure 1 - Fuse Panel

Fuse Position	Amps	Circuits Protection
1	15	Turn/Stop/Hazard Lamps; Speed Control
2	—	(Not used)
3	—	(Not used)
4	15	Exterior Lamps; Instrument Illumination
5	15	Turn Lamps; Backup Lamps; Rear Window Defrost
6	15	Speed Control; Electronic Shift-4 Wheel Drive
7	—	(Not Used)
8	15	Courtesy, Dome, Cargo Lamps; Warning Buzzer
9	30	Heater; A/C-Heater
10	20	Anti-lock Brakes
11	15	Radio; Main Light Switch; Clock Illumination
12	25	Tailgate Power Window; Power Mirrors
13	30 c.b.	Power Door Locks; Electronic Shift-4 Wheel Drive
14	—	(Not used)
15	25	Tailgate Power Window
16	30 c.b.	Power Windows
17	10	Auxiliary Fuel Tank Selector
18	30	Horn; Cigar Lighter; Speed Control; 4.9L EFI After Run Blower
	5	Instrument Illumination; Clock Dimming
	15	Seatbelt Buzzer; Warning Indicators; Carburetor Circuits; Tachometer; Diesel Glow Plug Control; Diesel Indicators; Electric Fuel Pump Control (7.5L)

Fuse Value Amps	Color Code
4	Pink
5	Tan
10	Red

Power Distribution

The **Alternator** and **Battery** are connected together at the **Starter Relay** hot terminal. Other circuits originate at the **Starter Relay** hot terminal and are protected by fuse links. Low power circuits are also protected by fuses.

The **Ignition Switch** and **Main Light Switch** are powered at all times as are **Fuses 1, 4, 8, 12, and 16**. The other fuses are powered through the **Ignition Switch** or the **Main Light Switch**.

100% SATISFACTION GUARANTEED

BUY IT NOW!

Click Here To Order

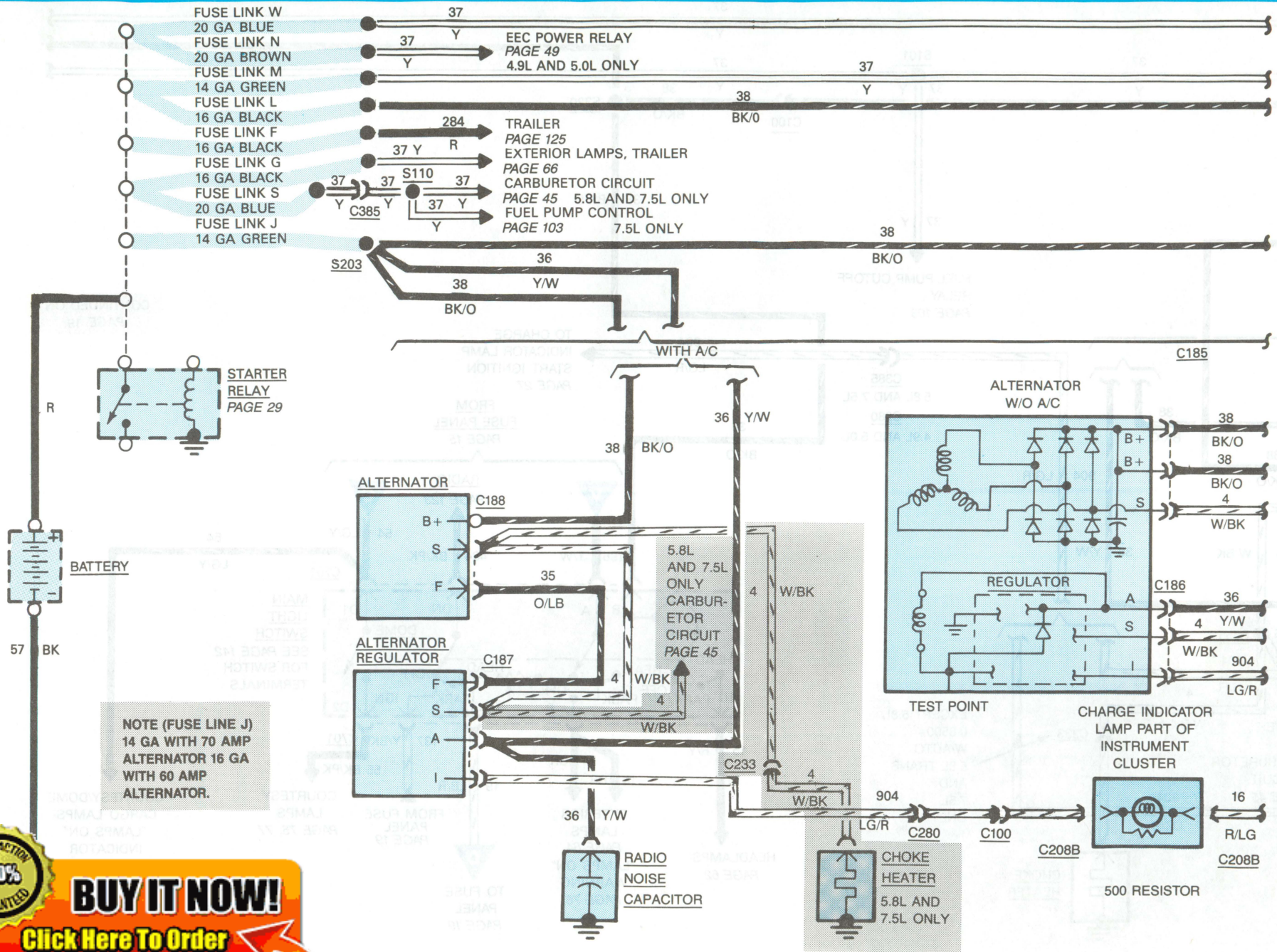

100% SATISFACTION GUARANTEED

BUY IT NOW!

Click Here To Order

18 CHARGE/POWER DISTRIBUTION (GASOLINE)

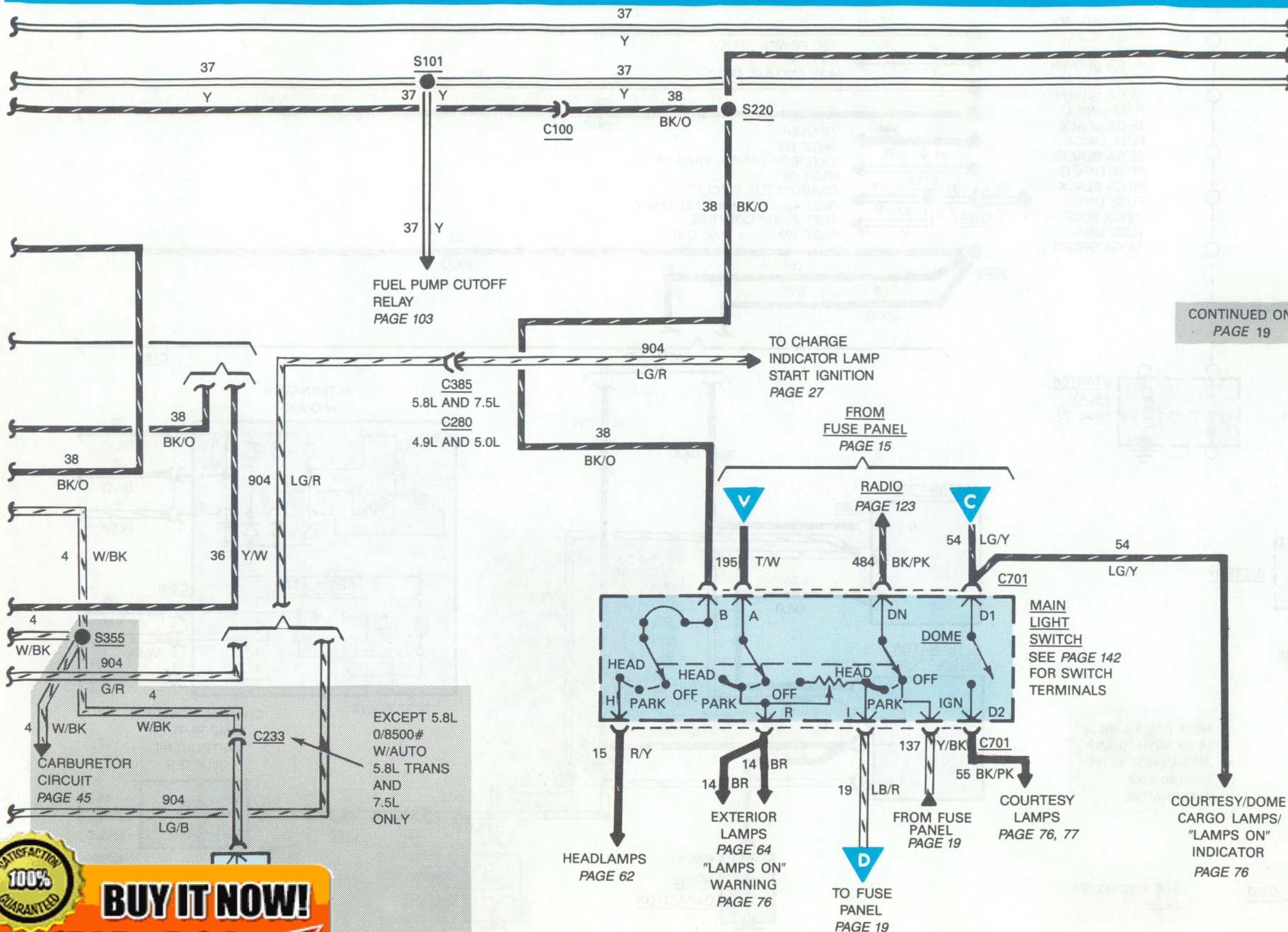

CONTINUED ON
PAGE 19



BUY IT NOW!

Click Here To Order



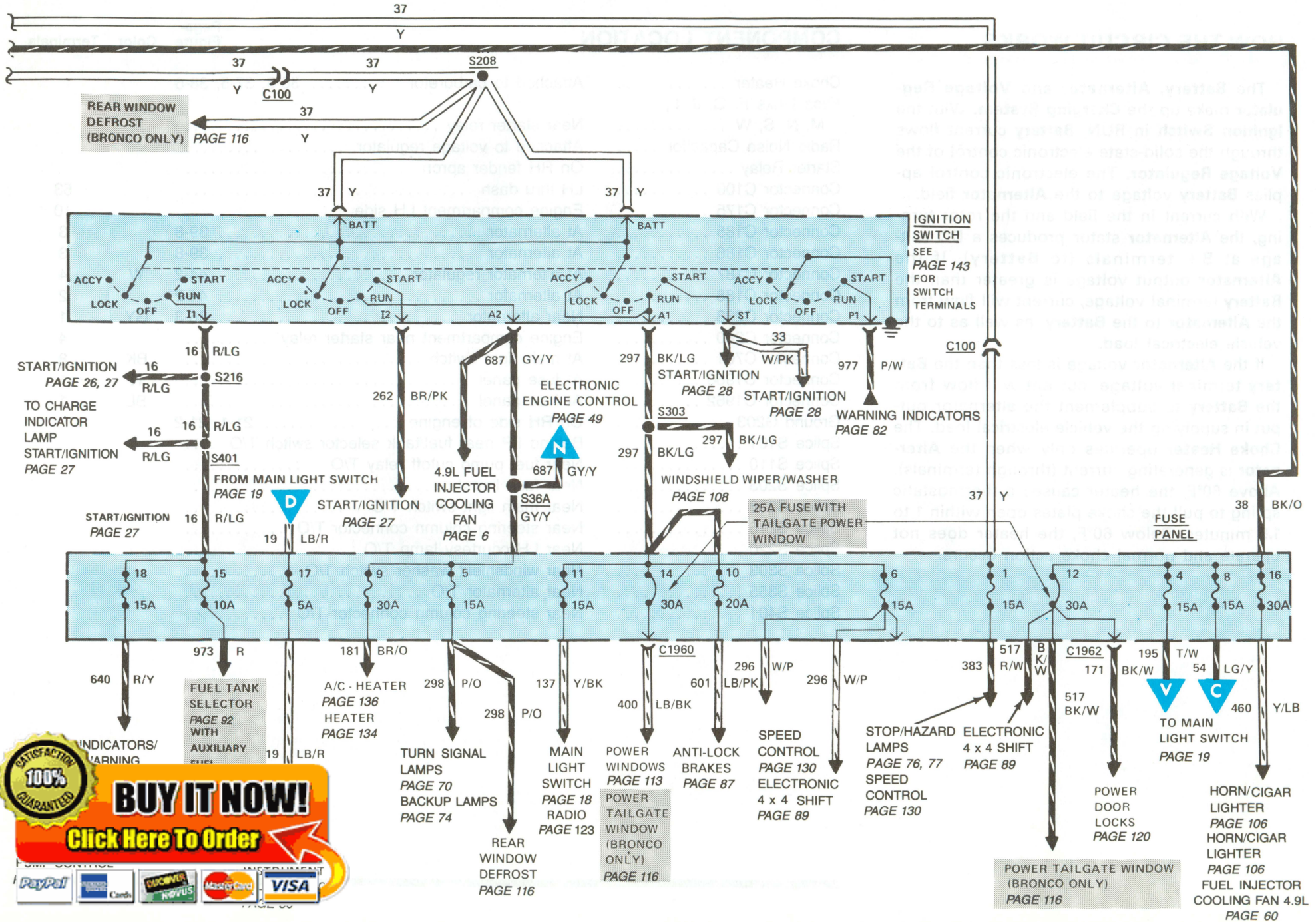

100% SATISFACTION GUARANTEED

BUY IT NOW!

Click Here To Order

HOW THE CIRCUIT WORKS

The **Battery**, **Alternator** and **Voltage Regulator** make up the **Charging System**. With the **Ignition Switch** in **RUN**, **Battery** current flows through the solid-state electronic control of the **Voltage Regulator**. The electronic control applies **Battery** voltage to the **Alternator** field.

With current in the field and the rotor turning, the **Alternator** stator produces a DC voltage at B+ terminals (to **Battery**). If the **Alternator** output voltage is greater than the **Battery** terminal voltage, current will flow from the **Alternator** to the **Battery**, as well as to the vehicle electrical load.

If the **Alternator** voltage is less than the **Battery** terminal voltage, current will flow from the **Battery** to supplement the alternator output in supplying the vehicle electrical load. The **Choke Heater** operates only when the **Alternator** is generating current (through terminals). Above 60°F, the heater causes a thermostatic spring to pull the choke plates open within 1 to 1.5 minutes. Below 60°F, the heater does not operate and normal choke action occurs.

COMPONENT LOCATION

		Page-Figure	Color	Terminals
Choke Heater	Attached to carburetor	36-3, 37-5, 38-6		
Fuse Links F, G, J, L, M, N, S, W	Near starter relay			
Radio Noise Capacitor	Attached to voltage regulator			
Starter Relay	On RH fender apron			
Connector C100	LH thru dash			53
Connector C175	Engine compartment LH side			10
Connector C185	At alternator	39-8		3
Connector C186	At alternator	39-8		3
Connector C187	At alternator regulator	44-2	W	4
Connector C188	At alternator	44-2		2
Connector C233	Near alternator	36-3	GY	1
Connector C280	Engine compartment near starter relay			4
Connector C701	At main light switch		BK	8
Connector C1960	At fuse panel		N	1
Connector C1962	At fuse panel		BL	1
Ground G203	On RH side of engine	21-1, 21-2		
Splice S101	Behind I/P near fuel/tank selector switch T/O			
Splice S110	Near fuel pump cutoff relay T/O			
Splice S203	Near fuse link J			
Splice S208	Near main light switch T/O			
Splice S216	Near steering column connector T/O			
Splice S220	Near LH courtesy lamp T/O			
Splice S303	Near windshield washer switch T/O			
Splice S355	Near alternator T/O			
Splice S401	Near steering column connector T/O			

100% SATISFACTION GUARANTEED

BUY IT NOW!

Click Here To Order

TROUBLESHOOTING HINTS

The most common charge system complaints are dead **Battery** and charge indicator **On** at normal speed.

- Check **Fuse Link J** at **Starter Relay**.
- Check **Alternator** belt tension.
- Check **Battery** terminals and cable clamps.
- Check for clean and tight connections on **Alternator** and **Starter Relay**.
- Read "Charging System Diagnosis" in the Shop Manual.

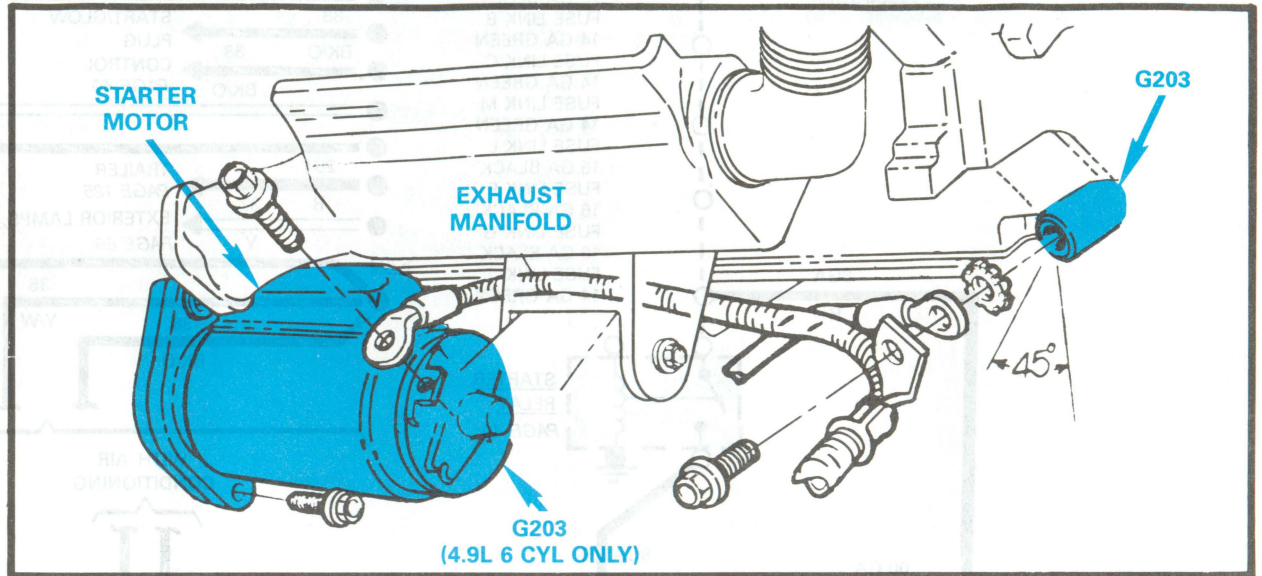

Figure 1 — Lower RH Side of Engine (5.0L, 5.8L, 7.5L, 8 Cyl.)

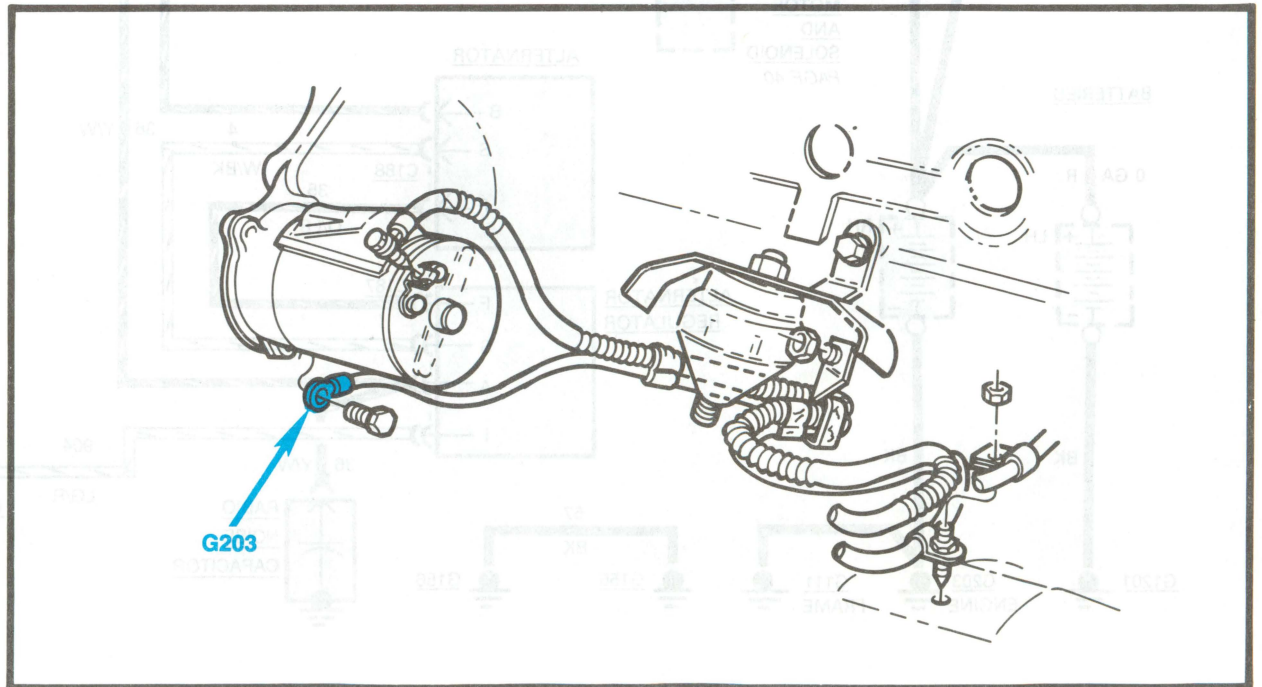

Figure 2 — Lower RH Side of Engine (4.9L 6 Cyl. ONLY)

100% SATISFACTION GUARANTEED

BUY IT NOW!

Click Here To Order

PayPal American Express Discover NetPlus MasterCard VISA

TERMINAL LOCATIONS ON SWITCH

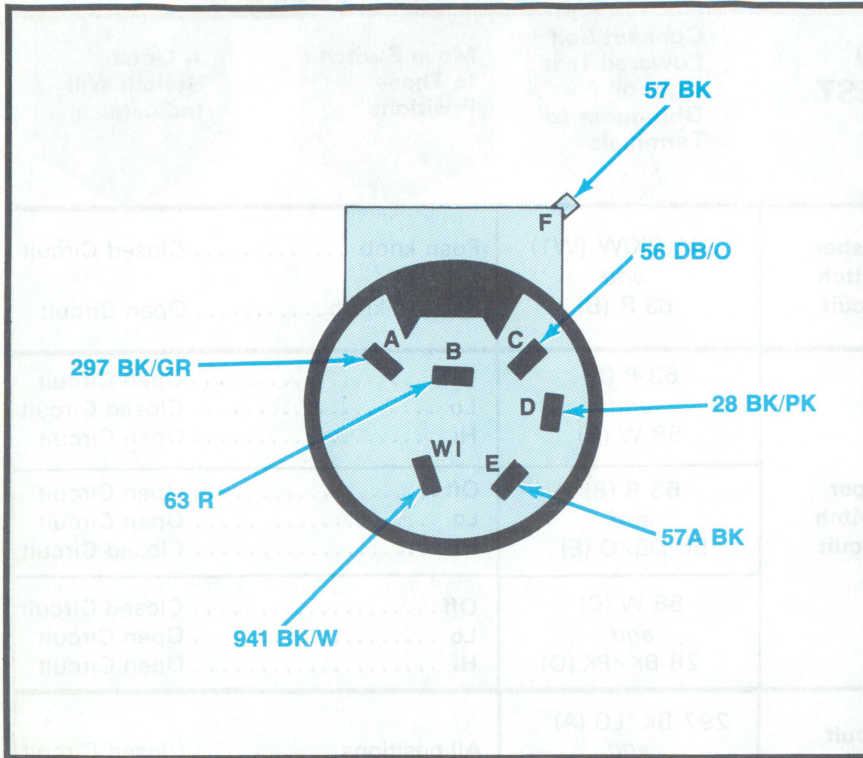

SCHMATIC

COMPONENT TESTING PROCEDURE

TO TEST	Connect Self-Powered Test Light or Ohmmeter to Terminals	Move Switch to These Positions	A Good Switch Will Indicate
Wiper Switch Circuit	57 BK (F) and 57A BK (E)	Off	Open Circuit
		All other positions	Closed Circuit
	63 R (B) and 56 DB/O (C)	Hi	Closed Circuit
		All other positions	Open Circuit
	28 BK/PK (D) and 57 BK (F)	Off	Open Circuit
		Rotate Control	Ohmmeter will indicate smoothly increasing resistance from 200-1000 ohms minimum to 5600-8400 ohms maximum
		Into Position (as Viewed from Connector Side).	
		All other positions	Closed Circuit

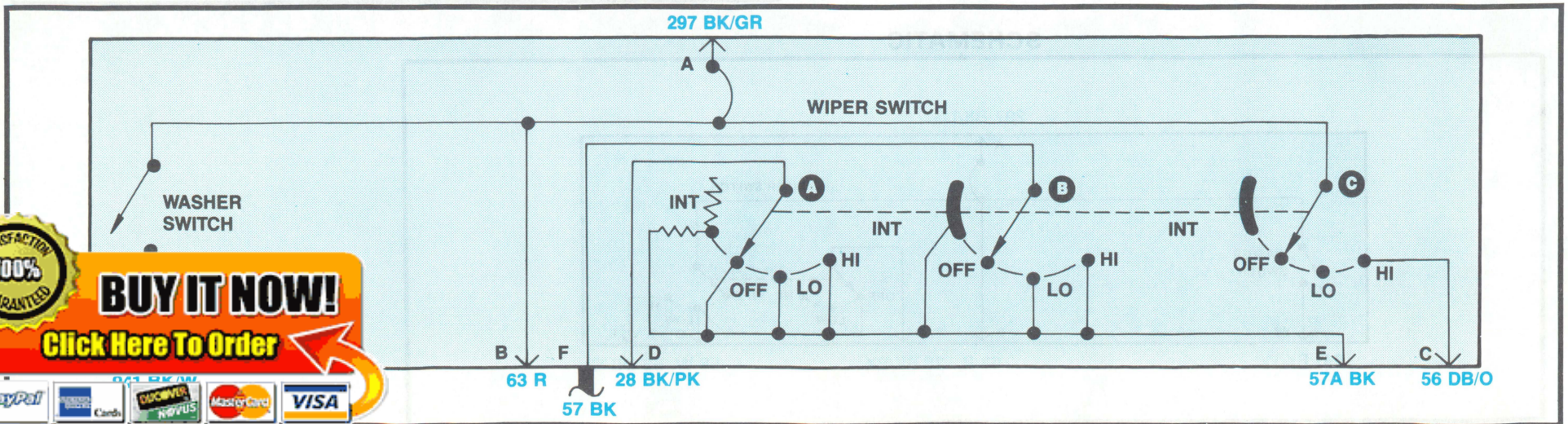

100% SATISFACTION GUARANTEED

BUY IT NOW!

Click Here To Order

TERMINAL LOCATIONS ON SWITCH

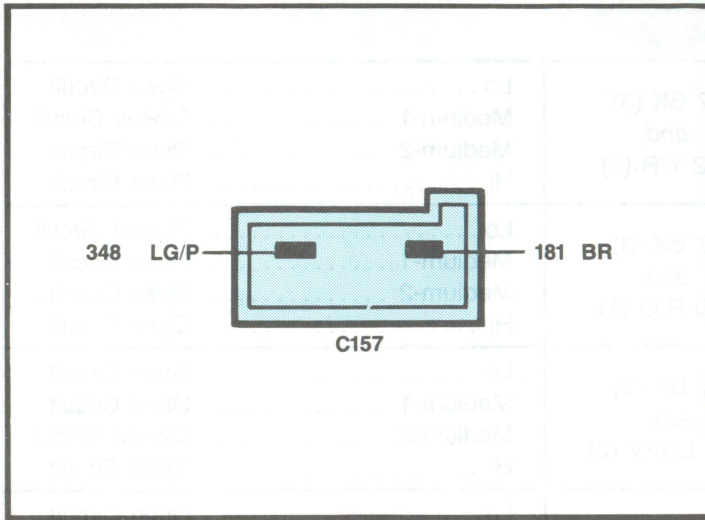

COMPONENT TESTING PROCEDURE

TO TEST	Connect Self Powered Test Light or Ohmmeter to Terminals	Move Control to These Positions	A Good Switch Will Indicate
A/C Clutch Circuit	181 BR/O and 348 LG/P	Off Open Circuit On Closed Circuit	

SCHEMATIC

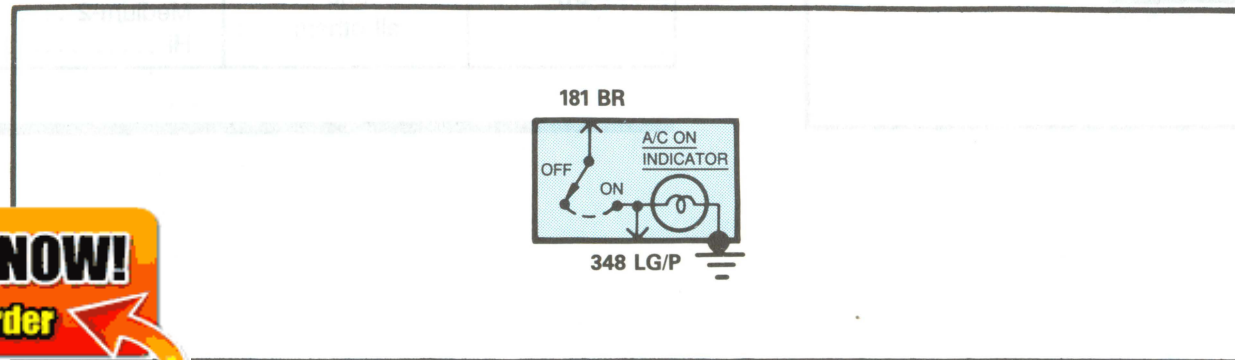

100% SATISFACTION GUARANTEED

BUY IT NOW!

Click Here To Order

TERMINAL LOCATIONS ON SWITCH

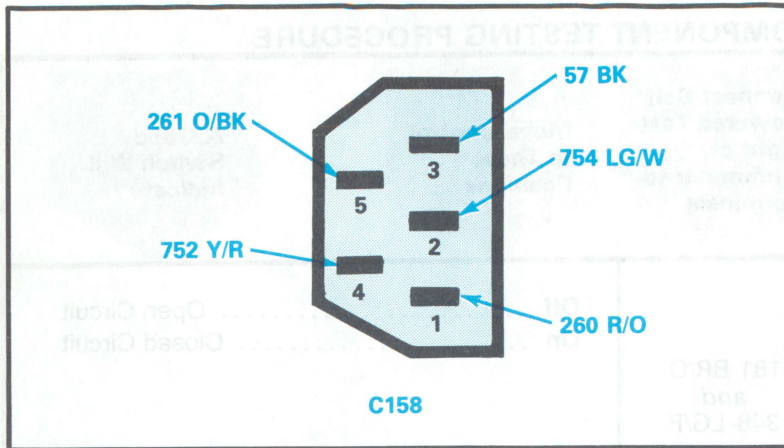

SCHEMATIC

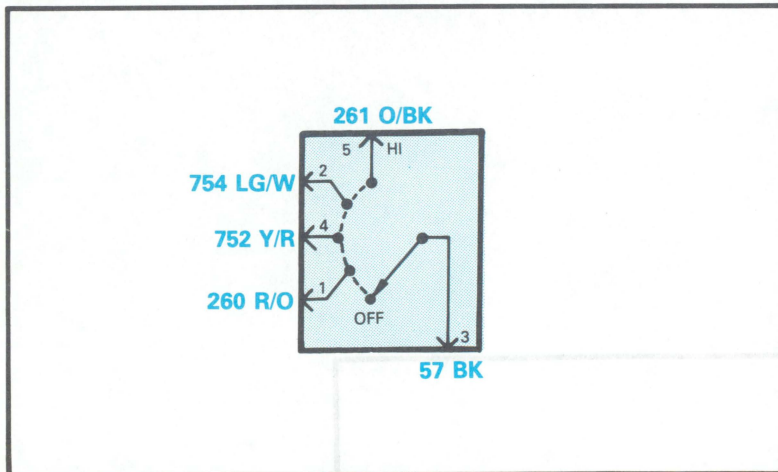

COMPONENT TESTING PROCEDURE

TO TEST	Connect Self-Powered Test Light or Ohmmeter to Terminals	Move Switch to These Positions	A Good Switch Will Indicate
Medium-Lo Speed	57 BK (3) and 752 Y/R (4)	Lo Medium-1 Medium-2 Hi	Open Circuit Closed Circuit Open Circuit Open Circuit
Low Speed	57 BK (3) and 260 R/O (1)	Lo Medium-1 Medium-2 Hi	Closed Circuit Open Circuit Open Circuit Open Circuit
Medium-High Speed (M2)	57 BK (3) and 754 LG/W (2)	Lo Medium-1 Medium-2 Hi	Open Circuit Open Circuit Closed Circuit Open Circuit
Hi Speed	57 BK (3) and 261 O/BK (5)	Lo Medium-1 Medium-2 Hi	Open Circuit Open Circuit Open Circuit Closed Circuit
Off	57 BK (3) and all others	Lo Medium-1 Medium-2 Hi	Open Circuit Open Circuit Open Circuit Open Circuit

100% SATISFACTION GUARANTEED

BUY IT NOW!

Click Here To Order



**WE SUPPORT VOLUNTARY
TECHNICIAN CERTIFICATION**



**Ford Parts and Service Division
Training and Publications Department**

100% SATISFACTION GUARANTEED

BUY IT NOW!

Click Here To Order 

PayPal    



FPS-12129-87