

1986 BRONCO / F150 / 350

1986 BRONCO/ F150/350



DEMO

This DEMO contains only a few pages of the entire manual/product.

Not all Bookmarks work on the Demo, but they do on the full version.

Features:

- Searchable text
- Printable pages
- Bookmarked for easy navigation
- High Resolution images
- Zoom to see exact details
- Money back Guarantee
- Available on USB and eBook download



BUY IT NOW!

Click Here To Order



Official
Licensed
Product

License #84356800

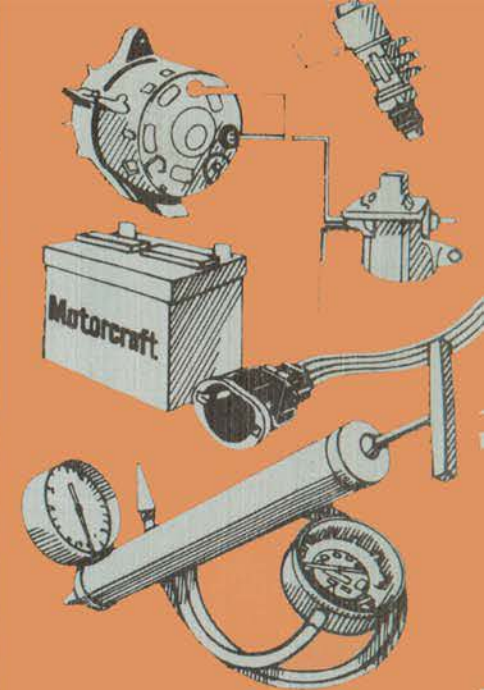

Electrical & Vacuum Trouble- Shooting Manual

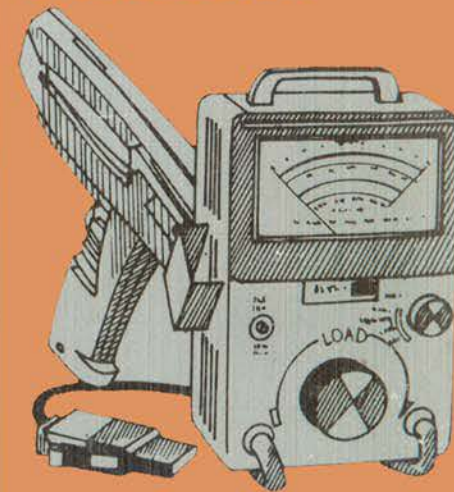

Copyright © 2023, Forel Publishing Company, LLC, Woodbridge, Virginia

All Rights Reserved. No part of this book may be used or reproduced in any manner whatsoever without written permission of Forel Publishing Company, LLC. For information write to Forel Publishing Company, LLC, Woodbridge, VA 22192

**1986 Bronco F150/350 Electrical & Vacuum
Trouble-Shooting Manual (EVTM)
EAN: 978-1-60371-409-9
ISBN: 1-60371-409-X**

Forel Publishing Company, LLC
Woodbridge, VA 22192
Email: sales@ForelPublishing.com
<https://www.ForelPublishing.com>



License #84356800

This publication contains material that is reproduced and distributed under a license from Ford Motor Company. No further reproduction or distribution of the Ford Motor Company material is allowed without the express written permission of Ford Motor Company.

Note from the Publisher

This product was created from the original Ford Motor Company's publication. Every effort has been made to use the original scanned images, however, due to the condition of the material; some pages have been modified to remove imperfections.

Disclaimer

Although every effort was made to ensure the accuracy of this book, no representations or warranties of any kind are made concerning the accuracy, completeness or suitability of the information, either expressed or implied. As a result, the information contained within this book should be used as general information only. The author and Forel Publishing Company, LLC shall have neither liability nor responsibility to any person or entity with respect to any loss or damage caused, or alleged to be caused, directly or indirectly by the information contained in this book. Further, the publisher and author are not engaged in rendering legal or other

advice, mechanical, electrical, or other expert assistance is required, the professional should be sought.





This Manual	1
and the Electrical Problem	2,3
Electrical)	4
vacuum)	132
and the Vacuum Problem	134
Panel (Back View)	
Testing	
ion	146
nt Switch	146
witch	147
Turn Switch	148
Windshield Wiper/Washer Switch	149
Interval Wiper/Washer Switch	150
A/C-Heater Function Selector	151
A/C-Heater Blower Switch	152

.....

A/C-Heater	141,145
Brake Warning Indicator	88
Carburetor Circuits	52-55
Charge (Gasoline)	14-18
(Diesel)	21-25
Choke Heater	15
Cigar Lighter	108,109
Coolant Temperature Gage	95,96,97,98,104
Diesel Glow Plug Control	47-51
Digital Clock	110,111
Electric Fuel Pump Control	101,107
Electronic Engine Control	56-65
Feedback Carburetor Control	56
Four-Wheel Drive Indicator	93,94,104
Fuel Gage (Diesel)	98
(Gasoline)	95,96
Fuel Tank Selector (Diesel)	98,101
(Gasoline)	95,97
Fuse Panel	12,13
Gages (Diesel)	98
(Gasoline)	95-97
Grounds	5-11

Heater	140
Horn	108,109
Ignition	26,46
Instrument Cluster Terminals	86
Instrument Illumination	86,87
Lamps On Warning	82,85
Lamps	
Backup	80,81
Cargo	82-85
Dome	82-85
Exterior	70-75
Hazard	76,79
Headlamps	66,69
Instrument Illumination	86,87
License	70,75
Map	82,85
Marker	70-75
Park	70-75
Radio Illumination	86
Stop	76,79
Tail (Rear Park)	70,75
Turn	76,79
Main Light Switch	66
Power Distribution (Diesel)	21,25
(Gasoline)	15-18
Power Door Locks	124,126
Power Windows	117,119
Radio (stereo) (Electronic)	128
(Stereo)	127,129
Rear Window Defrost	120,123
Seatbelt Warning	88,89
Speed Control	135,139
Start (Diesel)	47-51
(Gasoline)	26-46
Tachometer	98
Tailgate Power Window	120,123
Trailer	130,131
Vacuum Distribution	133

Warning Indicators (Diesel)	91,92
Warning Indicators (Gasoline)	88-90
Windshield Wiper/Washer	112,113
Wiper/Washer (Interval)	114,116

IMPORTANT SAFETY NOTICE

Appropriate service methods and proper repair procedures are essential for the safe, reliable operation of all motor vehicles, as well as the personal safety of the individual doing the work. This Manual provides general directions for accomplishing service and repair work with tested, effective techniques. Following them will help assure reliability.

There are numerous variations in procedures, techniques, tools, and parts for servicing vehicles, as well as in the skill of the individual doing the work. This Manual cannot possibly anticipate all such variations and provide advice or cautions as to each. Accordingly, anyone who departs from the instructions provided in this Manual must first establish that he compromises neither his personal safety nor the vehicle integrity by his choice of methods, tools or parts.

The purpose of this manual is to show electrical and vacuum circuits of these vehicles in a clear and simple fashion to make troubleshooting easier. With each circuit is a description of *How the Circuit Works* and some *Troubleshooting Hints*. A *Component Location* chart lists components, connectors, and grounds in that circuit. The chart includes a description of where each item is located, and references to pictures in the manual.

Wiring Diagrams give a schematic picture of when and how the circuit is powered, what the current path is to circuit components, and how the circuit is grounded. Each circuit component is named (underlined titles). Wire and connector colors are listed (standard Ford color abbreviations are used):

COLOR ABBREVIATIONS

BL	Blue	N	Natural
BK	Black	O	Orange
BR	Brown	PK	Pink
DB	Dark Blue	P	Purple
DG	Dark Green	R	Red
GR	Green	T	Tan
GY	Gray	W	White
LB	Light Blue	Y	Yellow
LG	Light Green		

Where two colors are shown for a wire, the first color is the basic color of the wire. The second color is the stripe marking. It should be noted that the use of dots and hashes for circuit identification has been eliminated. Dots may sometimes be encountered as an additional identifier if the wire harness manufacturer has used a different name identifier for the same connector.

Connector end views of switches and other components are shown to help with bench testing. The views show the harness wire colors that connect to the mating terminals. Connector colors and locations are shown in the *Component Location* chart. Two-color listings indicate separate colors for each connector half.

Components which work together are shown together. For example, all electrical components used in any circuit are shown on one diagram. The circuit breaker or fuse is shown at the top of the page. All wires, connectors, splices, switches, and motors are shown in the flow of current to ground at the bottom of the page. Notes are included which describe how switches and other components work. If a component is used in several different circuits, it is shown in several places. For example, the **Main Light Switch** is an electrical part of many circuits, and is repeated on many pages. In some cases, however, a component may seem, by its name, to belong on a page where it has no electrical connection. For example, **Radio Illumination** is electrically part of **Instrument Illumination**. Since it has no electrical connection at all with the actual **Radio** circuit, it is not shown on the **Radio** page.

Troubleshooting Hints point the technician in a general direction, but are not intended as a step-by-step procedure. Ignition troubleshooting is an exception to this. It includes a step-by-step procedure of basic quick checks to locate some of the more common **Ignition System** problems. Read the Shop Manual for more detailed repair procedures.

The **Grounds** pages show detailed views of multiple component ground points. This is useful for checking interconnections among the ground circuits of different diagrams.

Notes, Cautions, and Warnings appear in boxes on text pages and contain important **vehicle and mechanic safety information**.

Notes give added information to help complete a particular procedure. Cautions are included to prevent making an error that could damage the vehicle. Warnings highlight areas where carelessness can cause personal injury. The following list contains some general **Warnings** that should be followed when working on a vehicle.

- Always wear safety glasses for eye protection.
- Use safety stands whenever a procedure requires being under a vehicle.
- Be sure that the **Ignition Switch** is always in the OFF position, unless otherwise required by the procedure.
- Set the parking brake when working on any vehicle. An automatic transmission should be in PARK. A manual transmission should be in NEUTRAL.
- Operate the engine only in a well-ventilated area to avoid the danger of carbon monoxide.
- Keep away from moving parts when the engine is running, especially the fan and belts.
- To prevent serious burns, avoid contact with hot metal parts such as the radiator, exhaust manifold, tail pipe, catalytic converter, and muffler.
- Do not allow flame or sparks near the battery. Gases are always present in and around the battery cell. An explosion could occur.
- Do not smoke.
- To avoid injury, always remove rings, watches, loose hanging jewelry, and loose clothing.

HOW TO FIND THE ELECTRICAL PROBLEM

100% SATISFACTION GUARANTEED

Click Here To Order

BUY IT NOW!

PayPal
MasterCard
VISA

TROUBLESHOOTING STEPS

These steps present an orderly method of troubleshooting:

Step 1. Verify the problem.

Obtain the complete system and see all symptoms for yourself in order to: check the accuracy and completeness of the customer's complaint. Obtain more that might give a clue to the nature and location of the problem.

Step 2. Narrow the problem.

- Using this manual, narrow down the possible causes and locations of the problem in order to more quickly find the exact cause.
- Read the description of *How the Circuit Works* and study the wiring diagram. You should then know enough about the circuit operation to figure out where to check for this trouble.

Step 3. Test the cause.

- Use electrical test procedures to find the specific cause of the symptoms.
- *Troubleshooting Hints* will give some helpful ideas.
- The *Component Location* charts and the pictures will help you find components, grounds, and connectors.

Step 4. Verify the cause.

- Confirm the fact that you have found the correct cause through operating the parts of the circuit you think are good.

Step 5. Make the repair.

- Repair or replace the faulty component.

Step 6. Verify the repair.

- Operate the system as in Step 1 and check that your repair has removed all symptoms, and also has not caused any new symptoms.

Some engine circuits may need special test equipment and special procedures. See the

Shop Manual and other service books for details. You will find the circuits in this manual to be helpful with these special tests.

TROUBLESHOOTING TOOLS

JUMPER WIRE

This is a test lead used to connect two points of a circuit. A **Jumper Wire** can complete a circuit by bypassing an open.

Uses: Bypassing Switches or Open Circuits

WARNING

Never use a jumper wire across loads (motors, etc.) connected between hot and ground. This direct battery short may cause injury or fire.

VOLTMETER

A DC **Voltmeter** measures circuit voltage. Connect negative (- or black) lead to ground, and positive (+ or red) lead to voltage measuring point.

OHMMETER

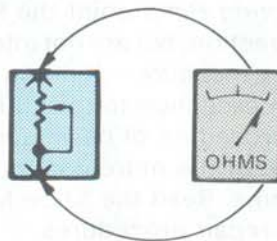

Figure 1— Resistance Check

An **Ohmmeter** shows the resistance between two connected points (Figure 1).

TEST LIGHT

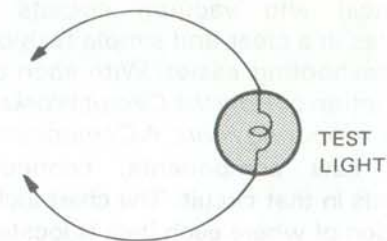

Figure 2 — Test Light

A **Test Light** is a 12-volt bulb with two test leads (Figure 2).

Uses: Voltage Check. Short Check

SELF-POWERED TEST LIGHT

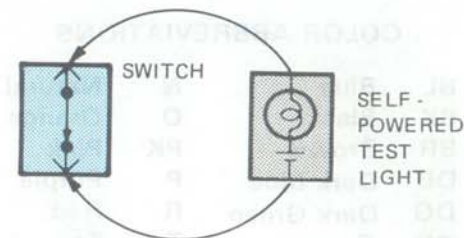

Figure 3—Continuity Check

The **Self-Powered Test Light** is a bulb, battery and set of test leads wired in series (Figure 3). When connected to two points of a continuous circuit, the bulb glows.

Uses: Continuity Check. Ground Check

CAUTION

When using a self-powered test light or ohmmeter, be sure power is off in circuit during testing. Hot circuits can cause equipment damage and false readings.

TROUBLESHOOTING CHECKS

SWITCH CIRCUIT CHECK

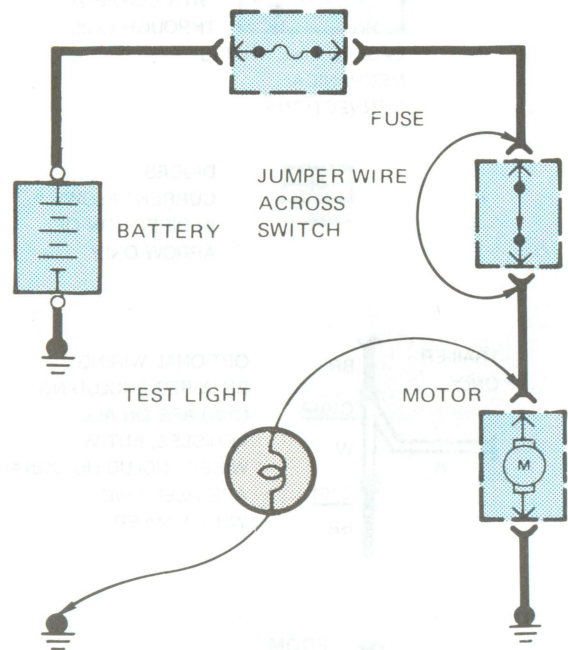

Figure 4—Switch Circuit Check and Voltage Check

In a bad circuit with a switch in series with the load, jumper the terminals of the switch to power the load. If jumping the terminals powers the circuit, the switch is bad (Figure 4).

CONTINUITY CHECK (Locating open circuits)

With power off, connect one lead of **Self-Powered Test Light** or **Ohmmeter** to each end of circuit (Figure 3). Light will glow if circuit is closed. Switches and fuses can be checked in this same way.

SHORT CHECK (short to ground)

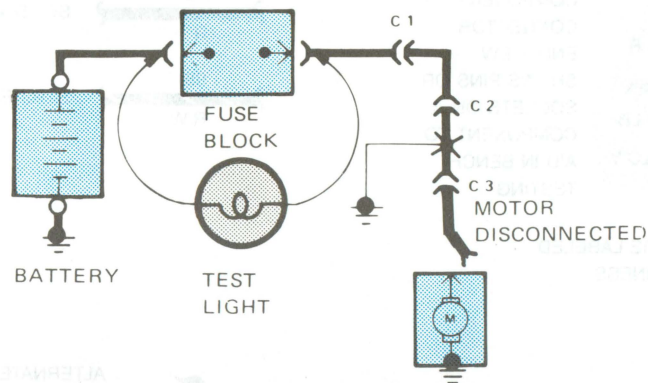

Figure 5—Short Check

A fuse that repeatedly blows is usually caused by a short to ground. It's important to be able to locate such a short quickly (Figure 5).

- 1) Turn off everything powered through the fuse.
- 2) Disconnect other loads powered through the fuse:
 - Motors: disconnect motor connector.
 - Lights: remove bulbs.
- 3) Turn **Ignition Switch** to RUN (if necessary) to power fuse.
- 4) Connect one **Test Light** lead to hot end of blown fuse. Connect other lead to ground. Bulb should glow showing power to fuse. *(This step is just a check to be sure you have power to the circuit.)*
- 5) Disconnect the **Test Light** lead from ground and reconnect it to the load side of the fuse.
 - If the **Test Light** is off, the short is in the disconnected equipment.
 - If the **Test Light** goes on, the short is in the wiring. You must find the short by disconnecting the circuit connectors one at a time until the **Test Light** goes out. For example: with a ground at X, the bulb goes out when C1 or C2 is disconnected, but stays on after disconnecting C3. This

means the ground is between C2 and C3.

"GOOD GROUND" CHECK

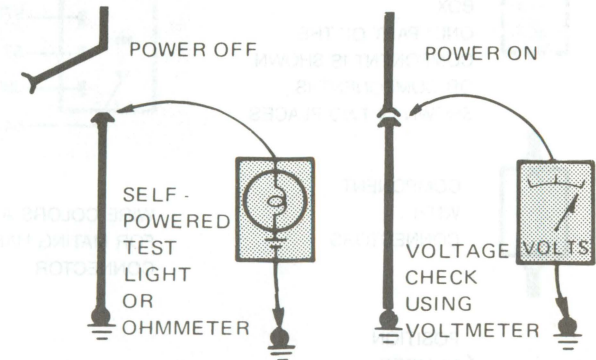

Figure 6 — Grounds Checks

Turn on power to circuit. Perform Voltage Check between suspected bad ground and frame. Any voltage means ground is bad.

Turn off power to circuit. Connect one lead of **Self-Powered Test Light** or **Ohmmeter** to wire in question, and the other to known ground. If bulb glows, circuit ground is OK (Figure 6).

TROUBLESHOOTING HINTS

The circuit schematics in this manual are designed to make it easy to identify common points in circuits. This knowledge can help narrow the problem to a specific area. For example, if several circuits fail at the same time, check for a common power or ground connection. (See *Power Distribution* or *Grounds*). If part of a circuit fails, check the connections between the part that works and the part that doesn't work.

For example, if low beam headlights work but high beams and the indicator light don't work, then power and ground paths must be good. Since the dimmer switch is the component which switches this power to the high beam lights and indicator, it is most likely the cause of failure.

100% SATISFACTION GUARANTEED

BUY IT NOW!

Click Here To Order

PayPal, American Express, Discover, MasterCard, VISA

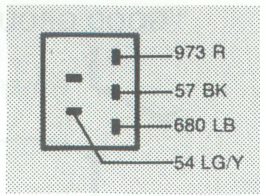
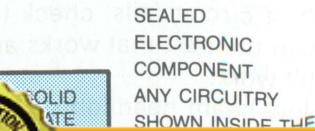
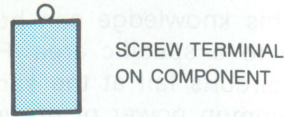
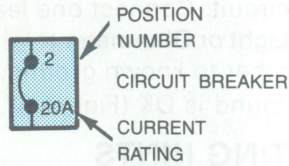
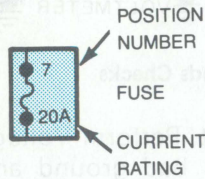
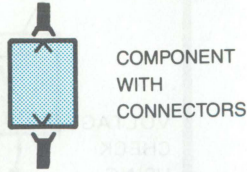
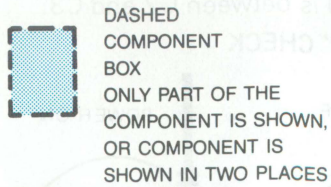

WIRE COLORS ARE LABELED FOR MATING HARNESS CONNECTOR

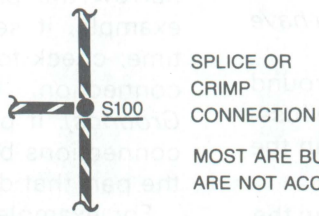
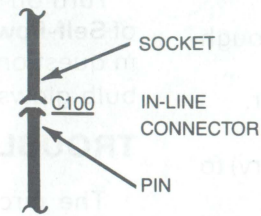

COMPONENT CONNECTOR END VIEW SHOWS PINS OR SOCKETS ON A COMPONENT TO AID IN BENCH TESTING

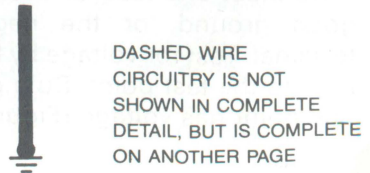
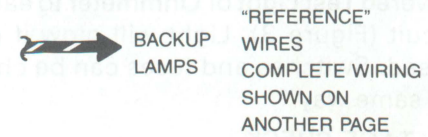
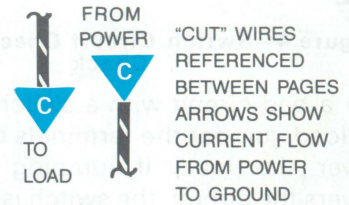
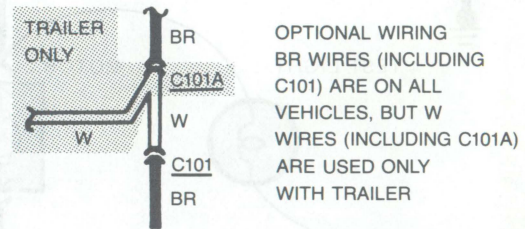
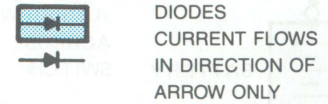
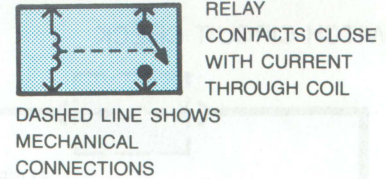
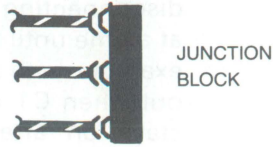
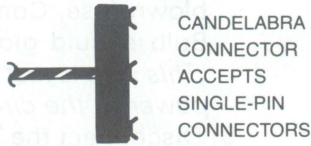
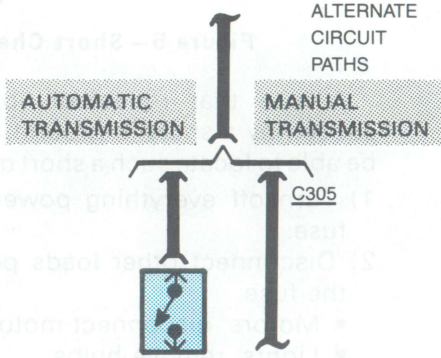
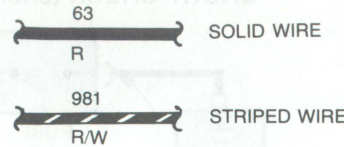

SEE GROUNDS PAGES 4, 5, 6, 7

100% SATISFACTION GUARANTEED

BUY IT NOW!

Click Here To Order

BRONCO

INSTRUMENT PANEL GROUND

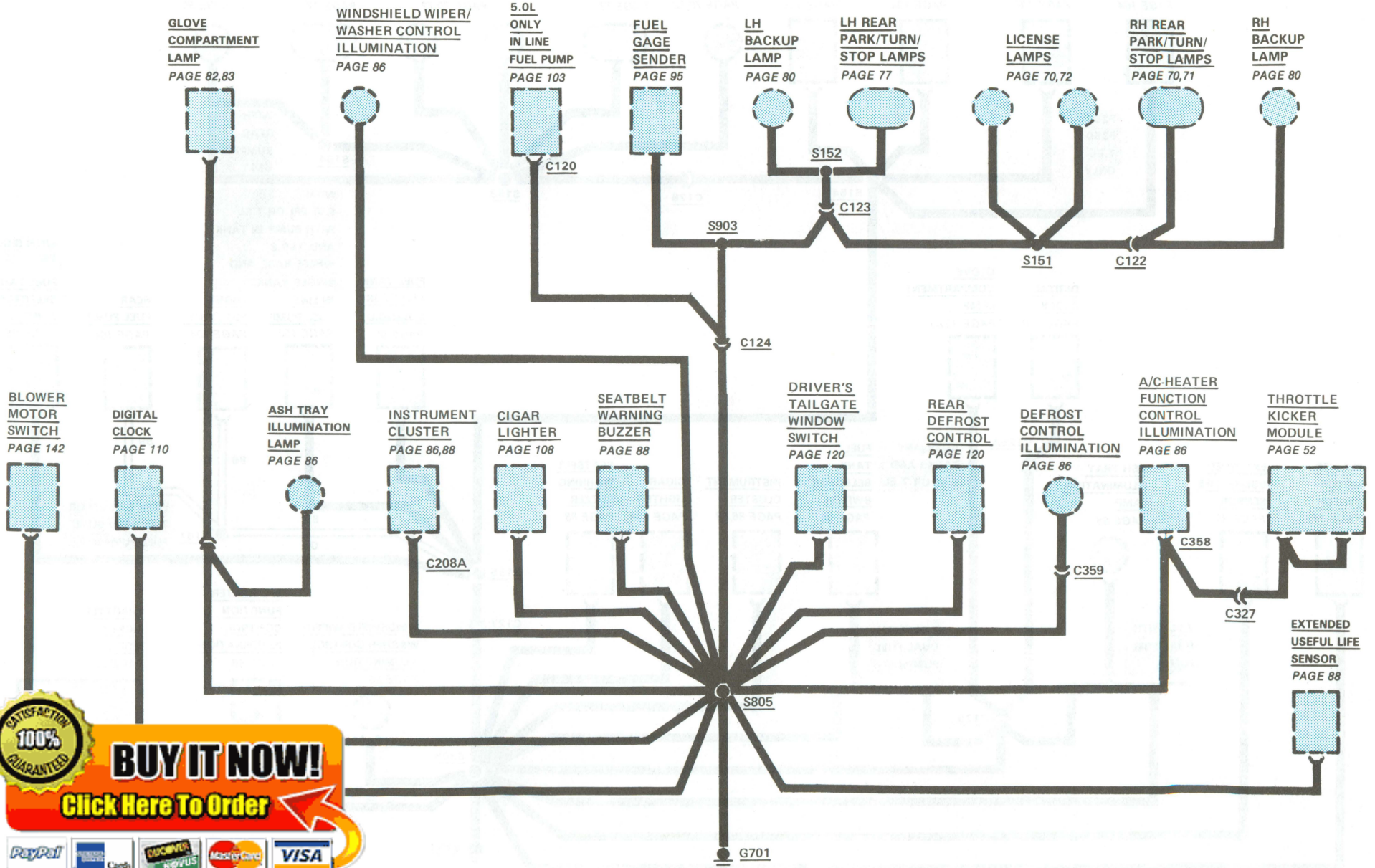

100% SATISFACTION GUARANTEED

BUY IT NOW!

Click Here To Order

PayPal American Express Discover MasterCard VISA

INSTRUMENT PANEL GROUND

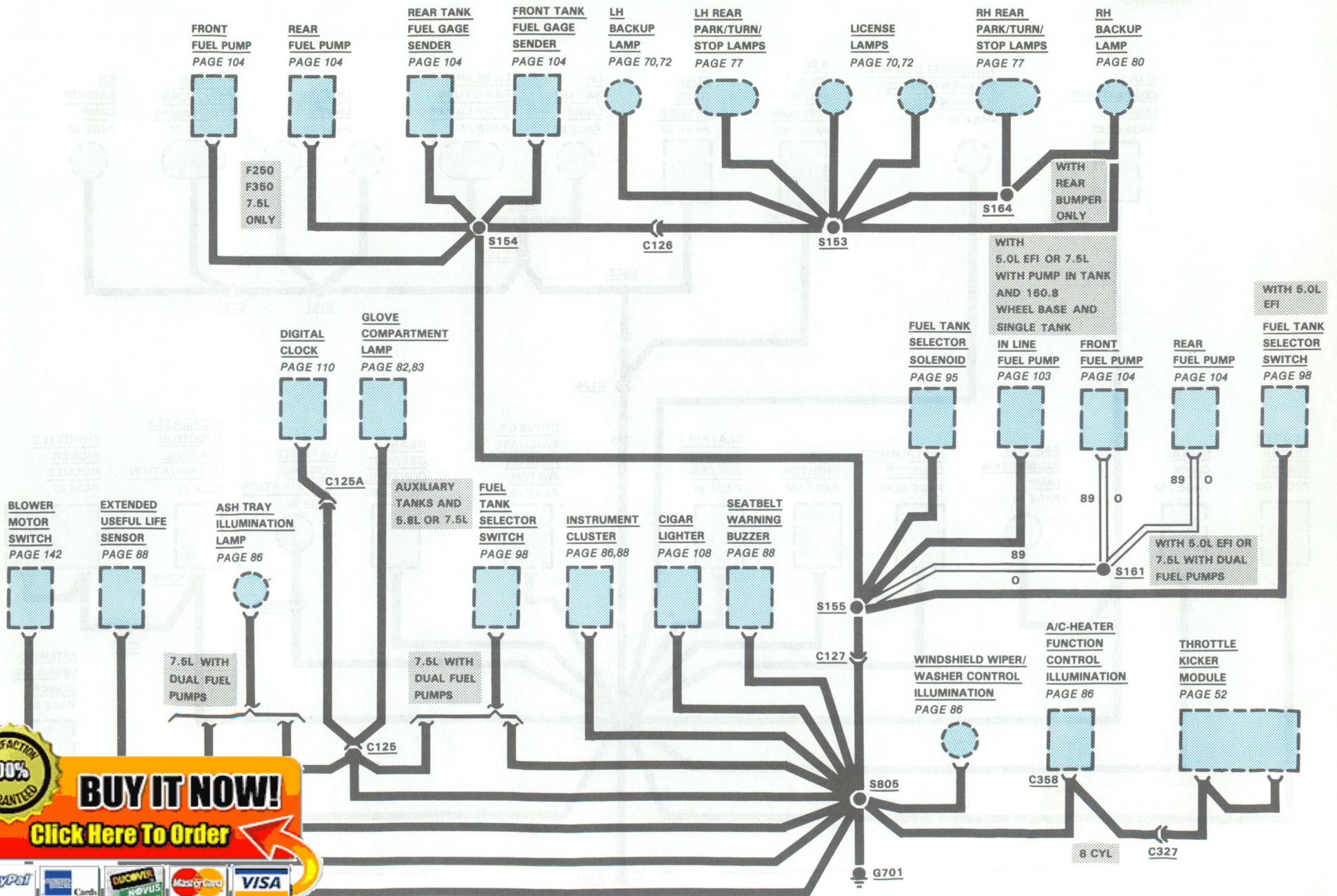

100% SATISFACTION GUARANTEED

BUY IT NOW!

Click Here To Order

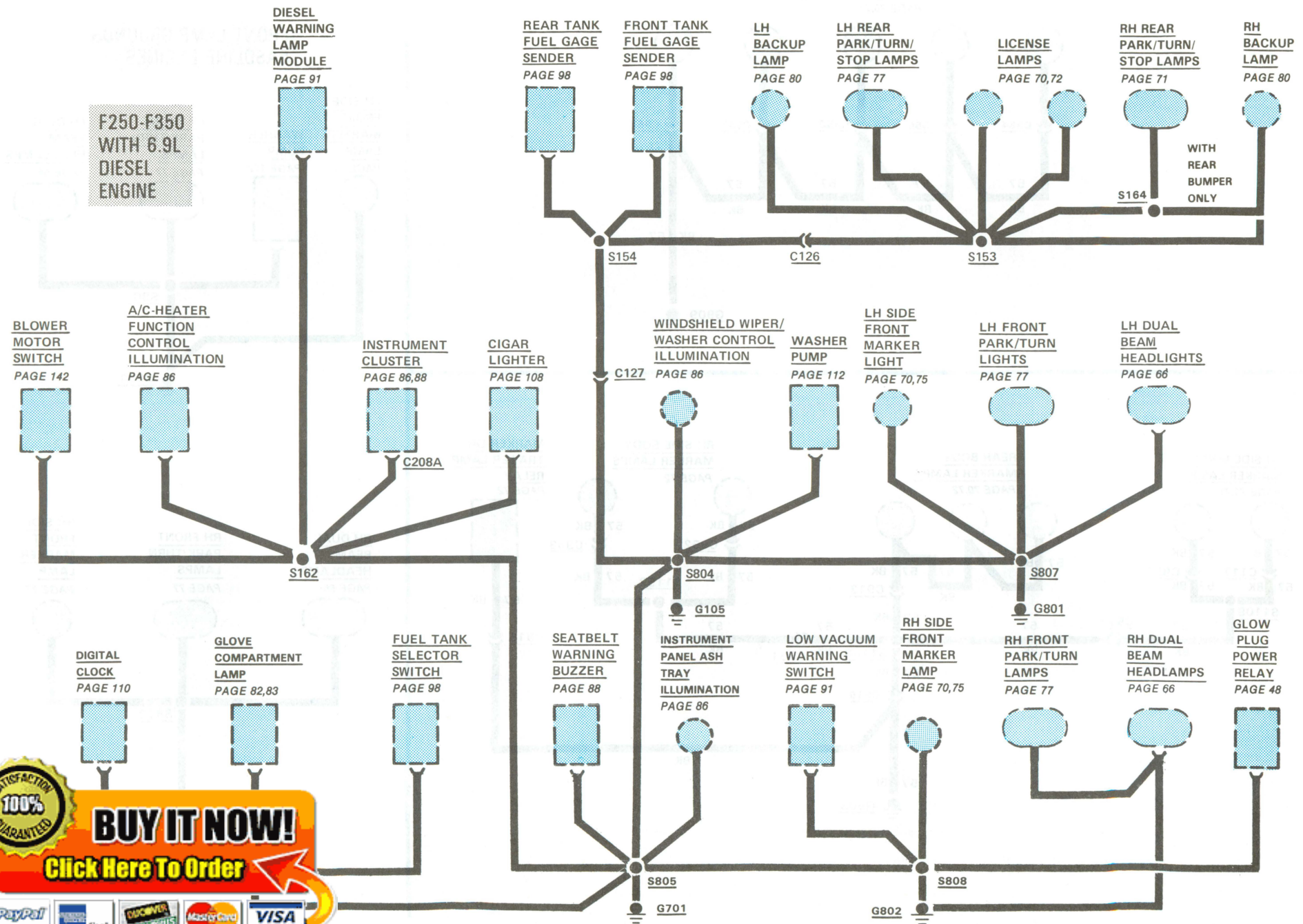

100% SATISFACTION GUARANTEED

BUY IT NOW!

Click Here To Order

8 GROUNDS (G801, G903, G909)

CAB MARKER LAMPS
PAGE 70,71

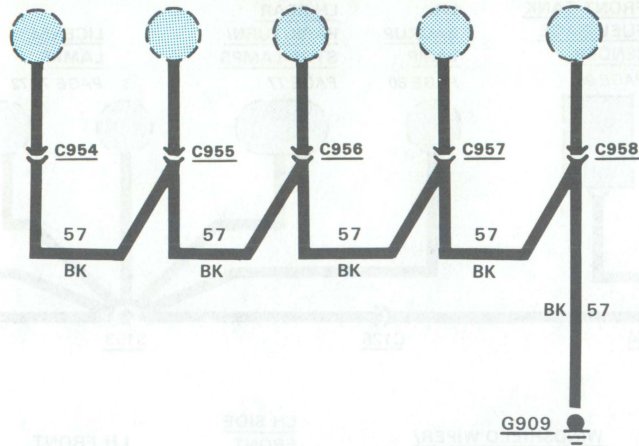

FRONT LAMP GROUNDS
GASOLINE ENGINES

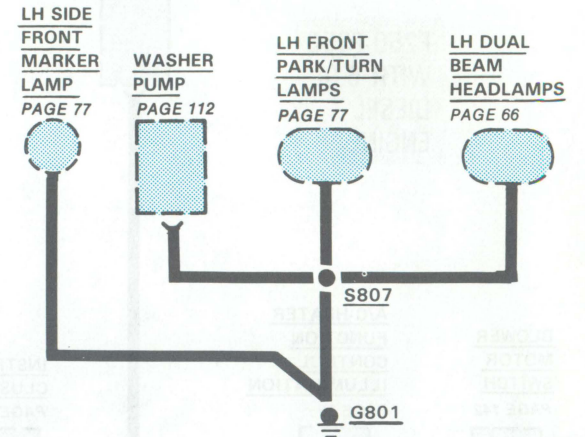

LH SIDE BODY MARKER LAMPS
PAGE 70,71

REAR BODY MARKER LAMPS
PAGE 70,72

RH SIDE BODY MARKER LAMPS
PAGE 72

MARKER OR TRAILER LAMP RELAY
PAGE 72

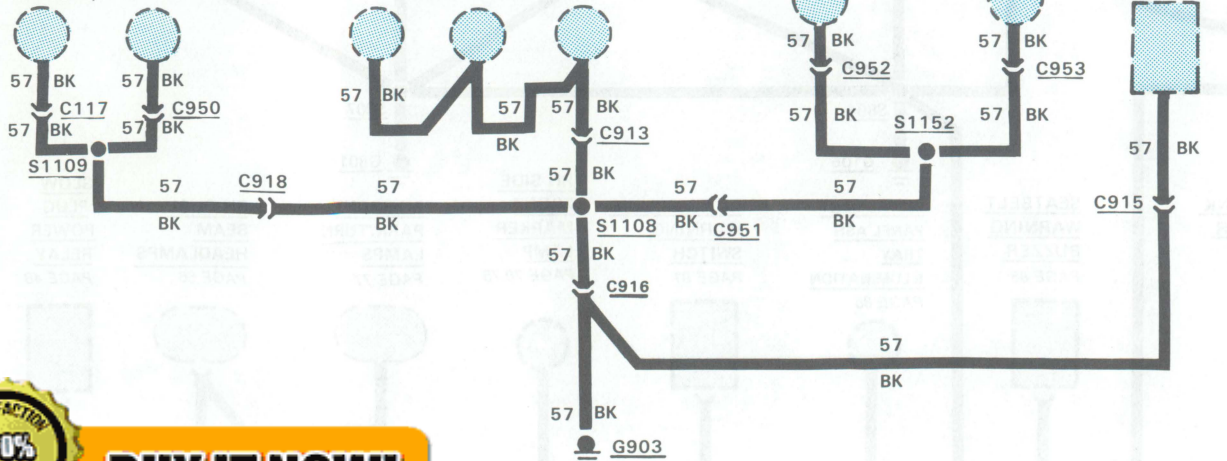

RH DUAL BEAM HEADLAMPS
PAGE 66

RH FRONT PARK/TURN LAMPS
PAGE 77

RH SIDE FRONT MARKER LAMP
PAGE 77

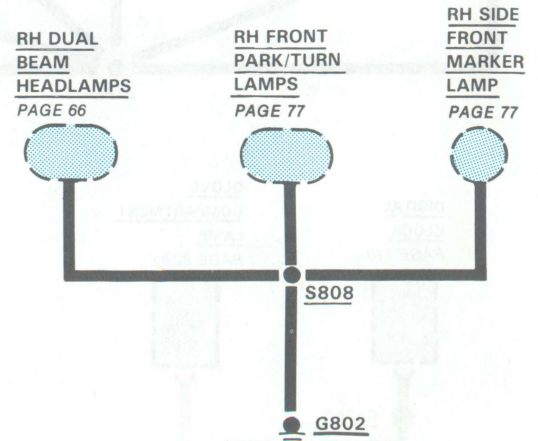

100% SATISFACTION GUARANTEED

BUY IT NOW!

Click Here To Order

FUEL
PUMP
CUTOFF
RELAY
PAGE 105

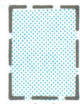

57 BK



G112

7.5L WITH FUEL PUMP
IN TANK AND 160.8" W/B
AND SINGLE TANK

POWER WINDOW
MASTER SWITCH
PAGE 111



57 BK

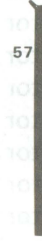

S854

57 BK



G752

LH POWER DOOR
LOCK CONTROL
SWITCH
PAGE 124



57 BK



S855



57 BK



C1958

57

BK



100% SATISFACTION GUARANTEED

BUY IT NOW!

Click Here To Order

EEC ONLY

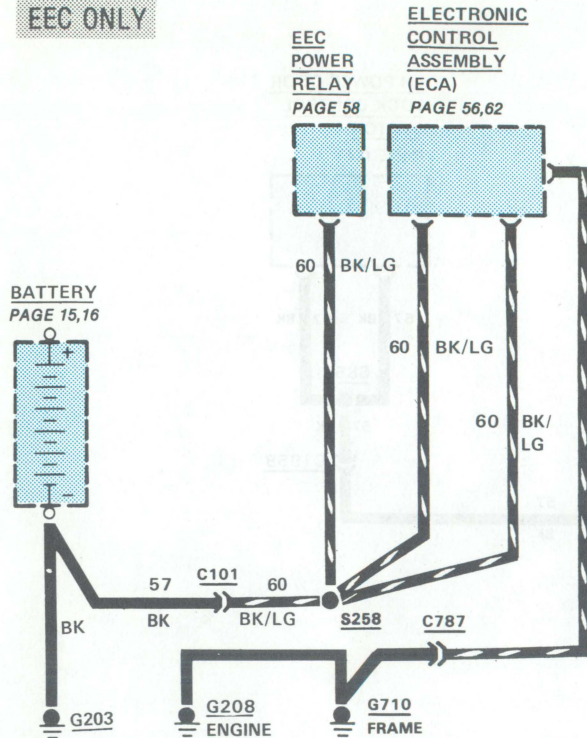

DIESEL

BATTERIES
PAGE 21

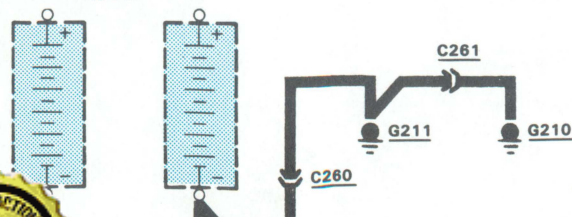

COMPONENT LOCATION

		Page-Figure	Color	Terminals
Connector C101	At battery ground pigtail		GY	1
Connector C117	At front of LH rear fender	75-8	BR	
Connector C122	RH side of rear cross support	74-3	BK	
Connector C123	LH side of frame at rear crossmember	75-9,79-1	NAT	
Connector C124	Lower side of LH dash panel	19-3	BK	
Connector C125	Behind center of I/P	67-3,69-5		
Connector C125A	Behind center of I/P	69-5		
Connector C126	Under frame at LH rear	74-2	BR	1
Connector C127	At LH dash	14-1,14-2,19-3,24-1,94-1	GY	4
Connector C208A	Attached to instrument cluster	66-2,68-4	GY	18
Connector C220	RH fender apron	20-1		1
Connector C260	Near RH battery	24-3		1
Connector C261	Near RH battery	24-3		1
Connector C327	Behind center of I/P	69-5,122-2,140-1	GY	3
Connector C358	Behind center of I/P	122-2,140-1	GY	2
Connector C359	Behind center of I/P	67-3,69-5,122-2	GR	2
Connector C787	RH side of dash			1
Connector C913	At center of rear body markers	75-5	GR	2
Connector C915	At LH dash	14-1,130-1	BK	2
Connector C916	At LH dash	74-2	BK	2
Connector C918	Near LH side of rear crossmember	74-2	GY	2
Connector C950	At LH rear fender	75-8	BR	2
Connector C951	Near RH side of rear crossmember	75-6	BR	2
Connector C952	At front of RH rear fender		BR	2
Connector C953	At rear of RH rear fender	75-8	BR	2
Connector C954	In forward part of roof cab	73-1	BK	2
Connector C955	In forward part of roof cab	73-1	BK	2
Connector C956	In forward part of roof cab	73-1	BK	2
Connector C957	In forward part of roof cab	73-1	BK	2
Connector C958	In forward part of roof cab	73-1	BK	2
Connector C1958	Near LH front door lock	118-1	BR	6

(Continued on next page)

100% SATISFACTION GUARANTEED

BUY IT NOW!

Click Here To Order

HOW THE CIRCUIT WORKS

The ground circuits shown here are complete and connect several components together to screw terminal ground points. On other pages only parts of these circuits may be shown. Partial ground circuits are shown dashed on those pages.

All simple or component ground circuits are shown on the individual circuit pages and are complete on those pages.

All ground wires are **57 BK** unless otherwise noted.

COMPONENT LOCATION

(Continued from previous page)

		Page-Figure	Color	Terminals
Ground G105	At water in fuel switch (diesel)	24-1		
Ground G108	At glow plug relay	20-1		
Ground G111	RH frame near battery	25-4		
Ground G112	Near fuel pump cutoff relay	107-1		
Ground G203	RH side of engine	19-5		
Ground G208	Near throttle position solenoid	36-4		
Ground G210	At electronic voltage regulator	20-1		
Ground G211	Near starter motor relay	20-1		
Ground G701	Behind I/P near RH side of radio	67-3		
Ground G710	LH side of dash panel	19-3		
Ground G752	LH door rear power window motor	118-1		
Ground G801	On LH inner fender behind headlamps	66-2		
Ground G802	On RH inner fender behind headlamp	14-3		
Ground G903	At LH side of rear crossmember	74-2		
Ground G909	At lower LH cowl access hole	75-7		
Ground G1201	On front LH side of engine	20-3		
Splice S151	Near license plate T/O			
Splice S152	Near LH backup lamp T/O			
Splice S153	Near license plate T/O			
Splice S154	Near front fuel gage sender T/O			
Splice S155	Near fuel tank selector valve solenoid T/O			
Splice S161	Near front fuel pump T/O			
Splice S162	Near heater control switch T/O			
Splice S164	Near license plate T/O			
Splice S258	Near EEC power relay T/O			
Splice S804	Near parking break switch T/O			
Splice S805	Near cigar lighter T/O			
Splice S807	Near LH front headlamp T/O			
Splice S808	Near RH park lamp T/O			
Splice S854	Near LH master window control T/O			
Splice S855	Near LH master window control T/O			
Splice S903	Near fuel gage sender and pump T/O			
Splice S1108	Near rear marker lamp T/O			
Splice S1109	Near LH front side marker lamp T/O			
Splice S1152	Near RH front side marker lamp T/O			

100% SATISFACTION GUARANTEED

BUY IT NOW!

Click Here To Order

PayPal American Express Discover MasterCard VISA

12 FUSE PANEL/CIRCUIT PROTECTION

REPLACEMENT OF FUSES/ CIRCUIT BREAKERS

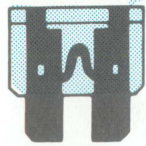

GOOD FUSE

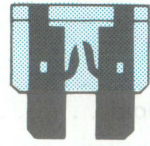

BLOWN FUSE

Fuses are mounted either in the **Fuse Panel** or in-line. They are identified by the numbered value in amperes, and by a color code. Some positions may have either a fuse with adapter or a circuit breaker. Be sure to replace a fuse or circuit breaker with the same kind of unit and with the same ampere rating. Remove fuses in order to check them.

CIRCUIT BREAKER OPERATION

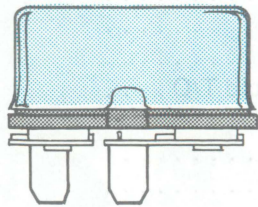

EXTERNAL
SIDE VIEW

CONTACTS

BIMETAL
ARM

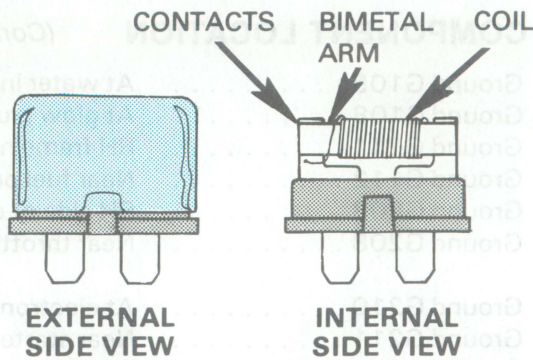
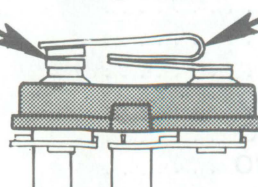

Non-Cycling Fuse Block Type

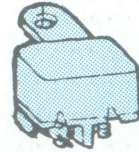

Cycling In-Line Type

Some circuits are protected by circuit breakers. (Abbreviated "c.b." in fuse chart.) They can be **Fuse Panel** mounted or in-line. Like fuses, they are rated in amperes.

Each circuit breaker conducts current through an arm made of two types of metal bonded together (bimetal arm). If the arm starts to carry too much current, it heats up. As one metal expands faster than the other, the arm bends, opening the contacts. Current flow is broken. In the cycling type, the arm cools and straightens out. This closes the circuit again. This cycle repeats as long as the overcurrent exists, with power applied.

In the non-cycling type, there is also a coil wrapped around the bimetal arm. When an overcurrent exists and the contacts open, a small current passes through the coil. This current through the coil is not large enough to operate a load, but it does heat up both the coil and bimetal arm. This keeps the arm in the open position until power is removed.

FUSE LINKS

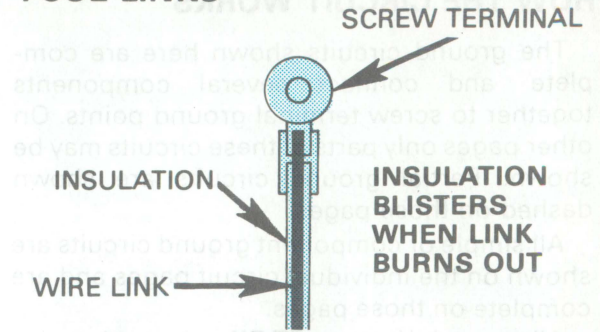

The fuse link is a short length of wire smaller in gage than the wire in the protected circuit. The wire is covered with a thick non-flammable insulation. An overload causes the link to heat and the insulation to blister. If the overload remains, the link will melt, causing an open circuit. The links are color coded for wire size as follows:

COLOR CODE

BLUE	20 GA
RED	18 GA
ORANGE	16 GA
GREEN	14 GA

When replacing, make tight crimp joints or hot solder joints for good connections.

DIODES



Diodes are electrical devices that permit current to flow in one direction only. The current flows in the direction indicated by the arrow.

100% SATISFACTION GUARANTEED

BUY IT NOW!

Click Here To Order

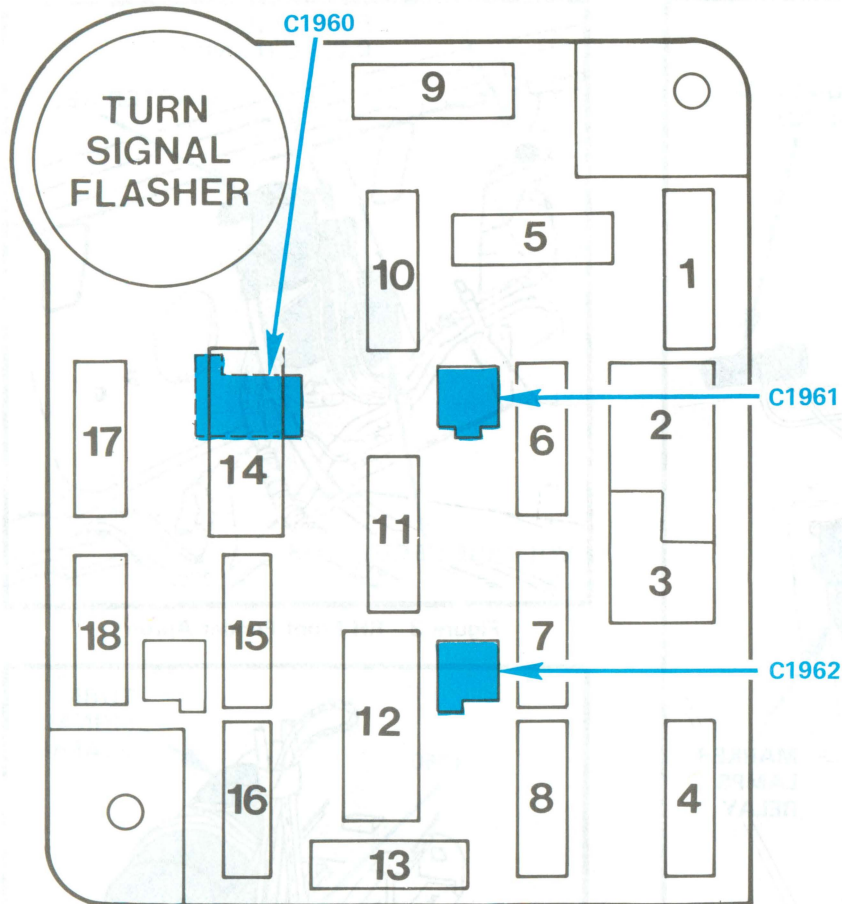

Figure 1 - Fuse Panel

Fuse Value Amps	Color Code
4	Pink
5	Tan

100% SATISFACTORY GUARANTEED

BUY IT NOW!

Click Here To Order

Fuse Position	Amps	Circuits Protected
1	15	Stop/Hazard Lamps; Speed Control
2	--	(Not used)
3	--	(Not used)
4	15	Exterior Lamps; Instrument Illumination
5	15	Turn Lamps; Backup Lamps
6	15	Speed Control; 4-Wheel Drive Indicator; Auxiliary Battery Control; Digital Clock; Rear Window Defrost; Feedback Carburetor Control (4.9L)
7	--	(Not used)
8	15	Courtesy, Dome, Cargo Lamps; Warning Buzzer
9	30	Heater; A/C-Heater
10	--	(Not used)
11	15	Radio
12	{ 25 30 c.b.	Tailgate Power Window Power Door Locks
13	--	(Not used)
14	{ 25 20 c.b.	Tailgate Power Window Power Windows
15	10	Auxiliary Fuel Tank Selector
16	20	Horn; Cigar Lighter
17	5	Instrument Illumination, Digital Clock
18	15	Seatbelt Buzzer; Warning Indicators; EEC; Carburetor Circuits; Tachometer; Choke Heater; Diesel Indicators Electric Fuel Pump Control (7.5L)

Power Distribution

The Alternator and Battery are connected together at the Starter Relay hot terminal. Other circuits originate at the Starter Relay hot terminal and are protected by fuse links. Low power circuits are also protected by fuses.

The Ignition Switch and Main Light Switch are powered at all times as are Fuses 1, 4, 8, 12, and 16. The other fuses are powered through the Ignition Switch or the Main Light Switch.

14 CHARGE/POWER DISTRIBUTION (GASOLINE ENGINES)

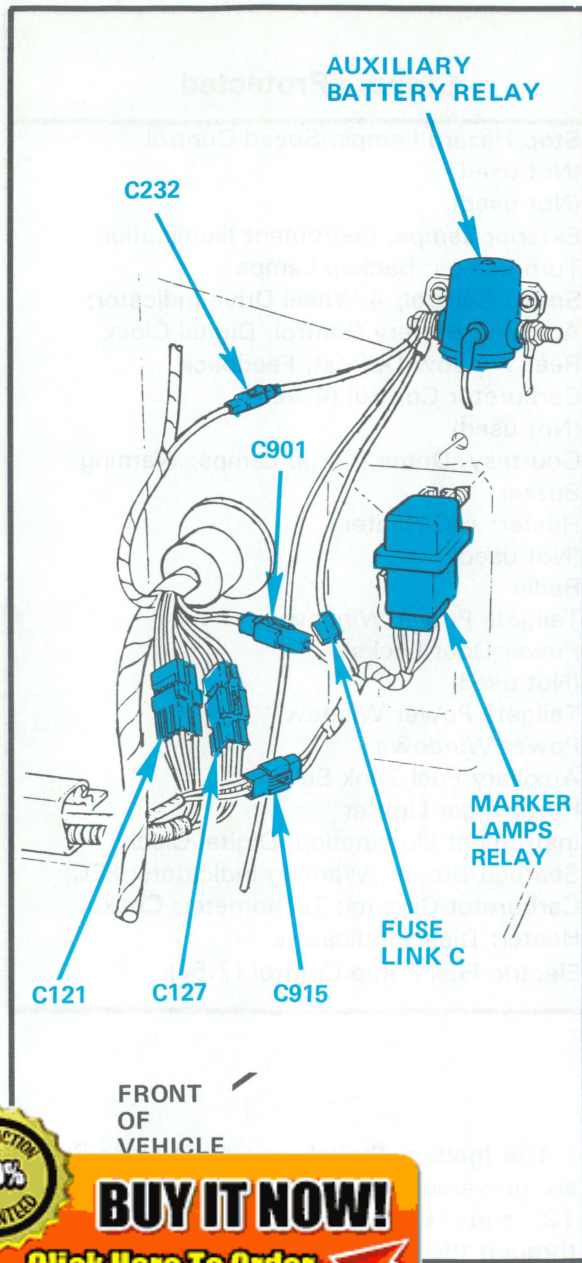

Rear Wheels

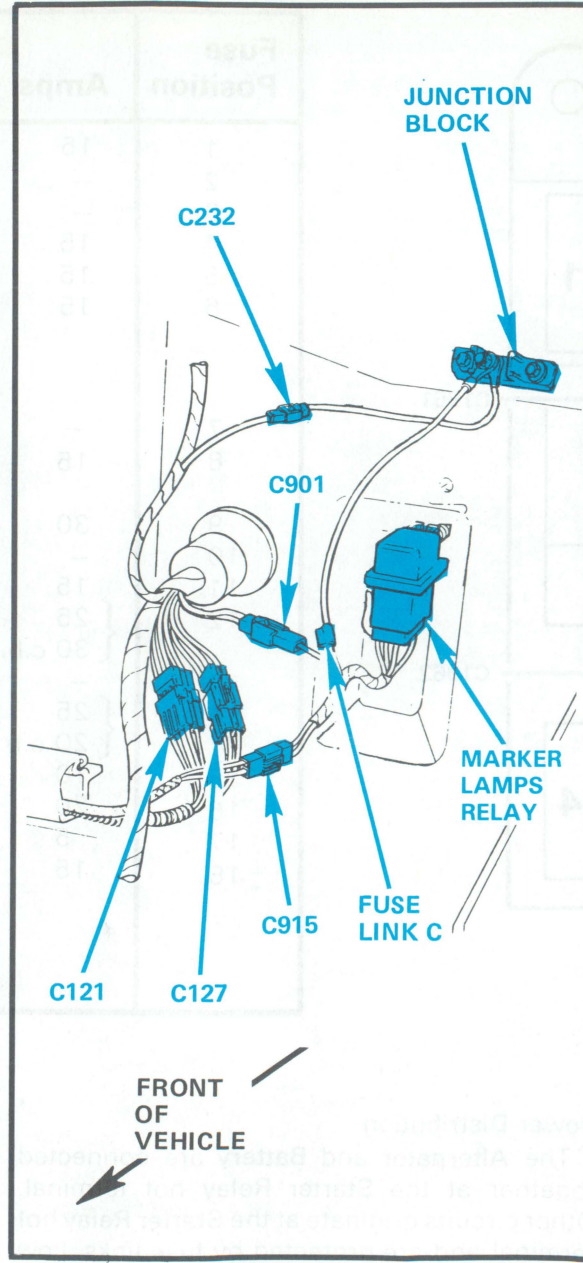

Figure 2 - LH Dash Panel For Dual Rear Wheels Without Dual Batteries

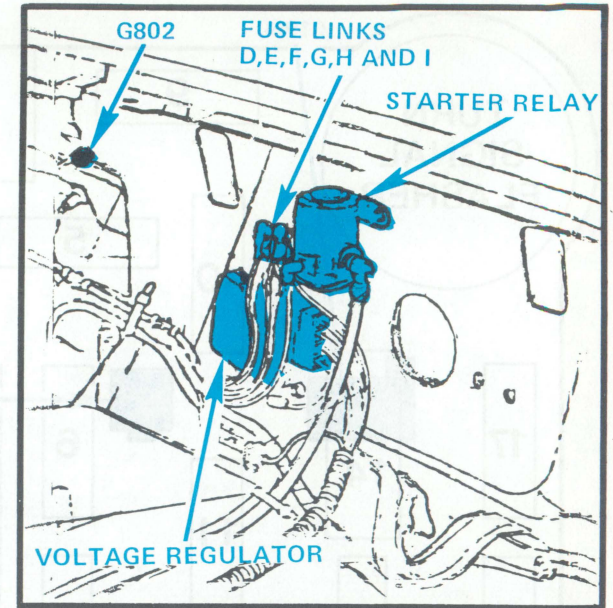

Figure 3 - RH Front Fender Apron

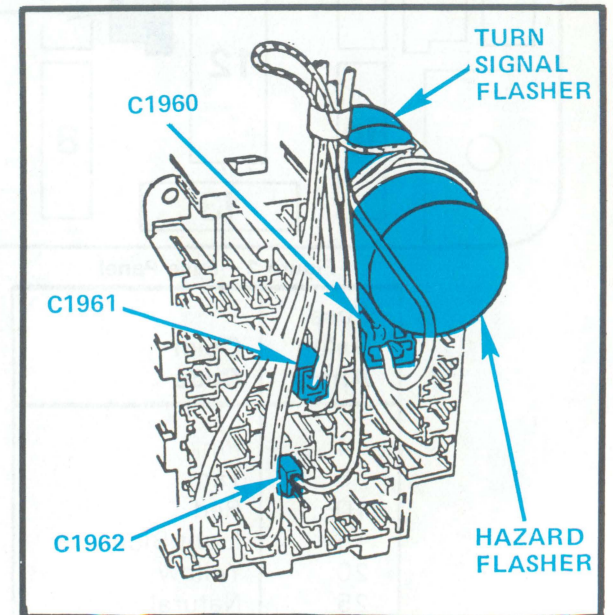

Figure 4 - Behind LH I/P, Rear Of Fuse Panel

100% SATISFACTORY GUARANTEED

BUY IT NOW!

Click Here To Order

PayPal, American Express, Discover, MasterCard, VISA

HOW THE CIRCUIT WORKS

The **Battery** and **Alternator** with integral **Voltage Regulator** make up the **Charging System**. With the **Ignition Switch** in **RUN**, **Battery** current flows through the solid-state electronic control of the **Voltage Regulator**. The electronic control applies **Battery** voltage to the **Alternator** field.

With current in the field and the rotor turning, the **Alternator** stator produces a DC voltage at **B+** terminals (to **Battery**). If the **Alternator** output voltage is greater than the **Battery** terminal voltage, current will flow from the **Alternator** to the **Battery**, as well as to the vehicle electrical load. Current flowing to the battery will show as a charging current on the **Ammeter** (deflection toward "charge"). If the battery is charged, the ammeter deflection will be small unless power windows or door locks are activated. Operation of these intermittent devices will give a charge indication on the **Ammeter**.

If the **Alternator** voltage is less than the **Battery** terminal voltage, current will flow from the **Battery** to supplement the alternator output in supplying the vehicle electrical load. This current flow will register as a "discharge" on the **Ammeter**. The **Choke Heater** operates only when the **Alternator** is generating current (through terminals). Above 60°F, the heater causes a thermostatic spring to pull the choke plates open within 1 to 1.5 minutes. Below 60°F, the heater does not operate and normal chocking occurs.

COMPONENT LOCATION

		Page- Figure	Color	Terminals
Choke Heater	Attached to carburetor	39-9		
Fuse Links B, P	At junction block or marker lights relay	130-7		
Fuse Link C	At junction block or auxiliary battery relay	14-2		
Fuse Link F	At starter relay	14-3		
Fuse Links J, L, M, N, S, AX	Near RH fender apron and dash panel	19-1,20-1,24-3		
Junction Block	Mounted on LH dash panel	24-1		
Radio Noise Capacitor	Attached to voltage regulator	35-2		
Starter Relay	On RH fender apron	14-3,20-1		
Voltage Regulator	Mounted on RH fender apron	19-1,20-1		
Connector C139	Front side of alternator/regulator	24-3		
Connector C185	Attached to alternator			3
Connector C186	Attached to alternator			3
Connector C208	Attached to instrument cluster	40-10	GY	14
Connector C208A	Attached to instrument cluster	66-2,68-4	GY	18
Connector C231	Front right of engine	43-17		
Connector C232	LH dash panel, near junction block	14-1		
Connector C233	At alternator	39-9		
Connector C610	Below voltage regulator	20-2		
Connector C701	Attached to main light switch	67-3		
Connector C1960	On fuse panel	14-4		
Connector C1961	On fuse panel	14-4		
Connector C1962	On fuse panel	14-4		
Ground G203	On RH side of engine	19-5		
Ground G1201	On LH front fender, near battery	20-3		
Splice S101	Near fuel tank selector switch T/O			
Splice S102	Near fuel tank selector switch T/O			
Splice S103	Near fuel tank selector switch T/O			
Splice S150	Near fuse panel power door lock T/O			
Splice S202	Near fuse link J			
Splice S203	Near fuse link J			
Splice S204	Near alternator T/O			
Splice S208	Near headlamp switch T/O			
Splice S216	Near breakerless ignition module T/O			
Splice S220	Near ignition switch T/O			
Splice S303	Near headlamp switch T/O			
Splice S401	Near headlamp switch T/O			
Splice S858	Near 4 × 4 indicator lamp T/O			

100% SATISFACTION GUARANTEED

BUY IT NOW!

Click Here To Order

PayPal American Express Discover MasterCard VISA

18 CHARGE/POWER DISTRIBUTION

TROUBLESHOOTING HINTS

The most common charge system complaints are dead **Battery** and **Ammeter** discharging at normal speed.

- Check **Fuse Link J** (Ammeter) at **Starter Relay**.
- Check **Alternator** bolt tension.
- Check **Battery** terminals and cable clamps.
- Check for clean and tight connections on **Alternator** and **Starter Relay**.
- Read "Charging System Diagnosis" in the Shop Manual.



BUY IT NOW!
Click Here To Order



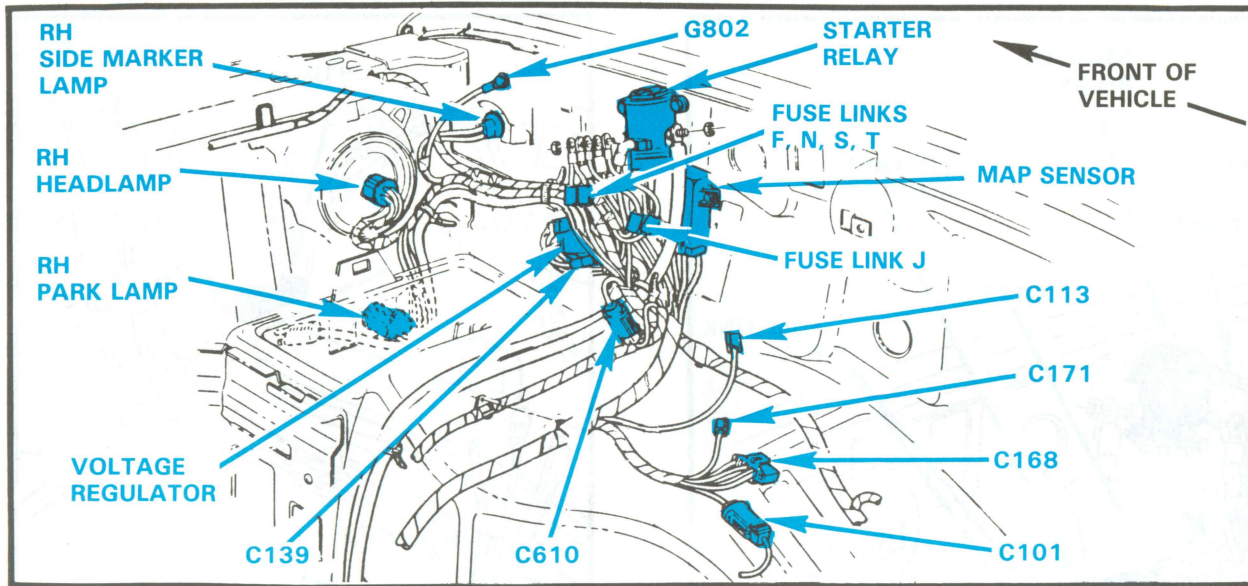

Figure 1 – RH Front Fender Apron (With EEC)

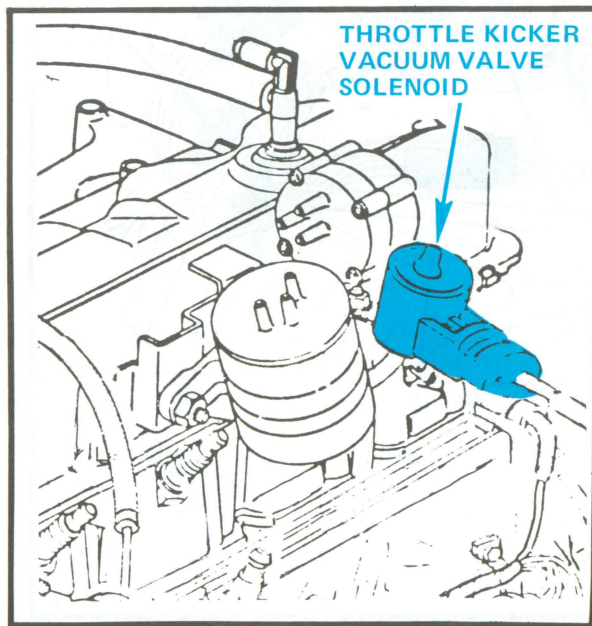

Figure 3 – LH Rear Of 4.9L Engine (Duraspark II)

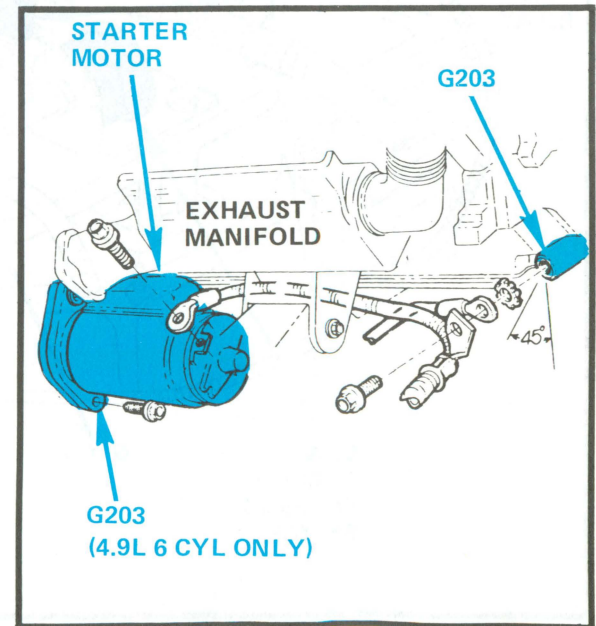

Figure 2 – Lower RH Side of Engine

100% SATISFACTION GUARANTEED

BUY IT NOW!

Click Here To Order

20 CHARGE/POWER DISTRIBUTION

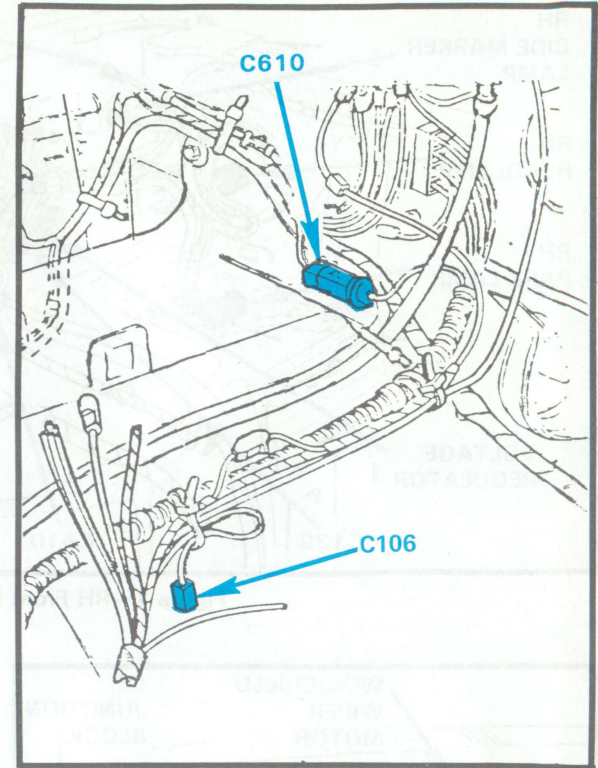
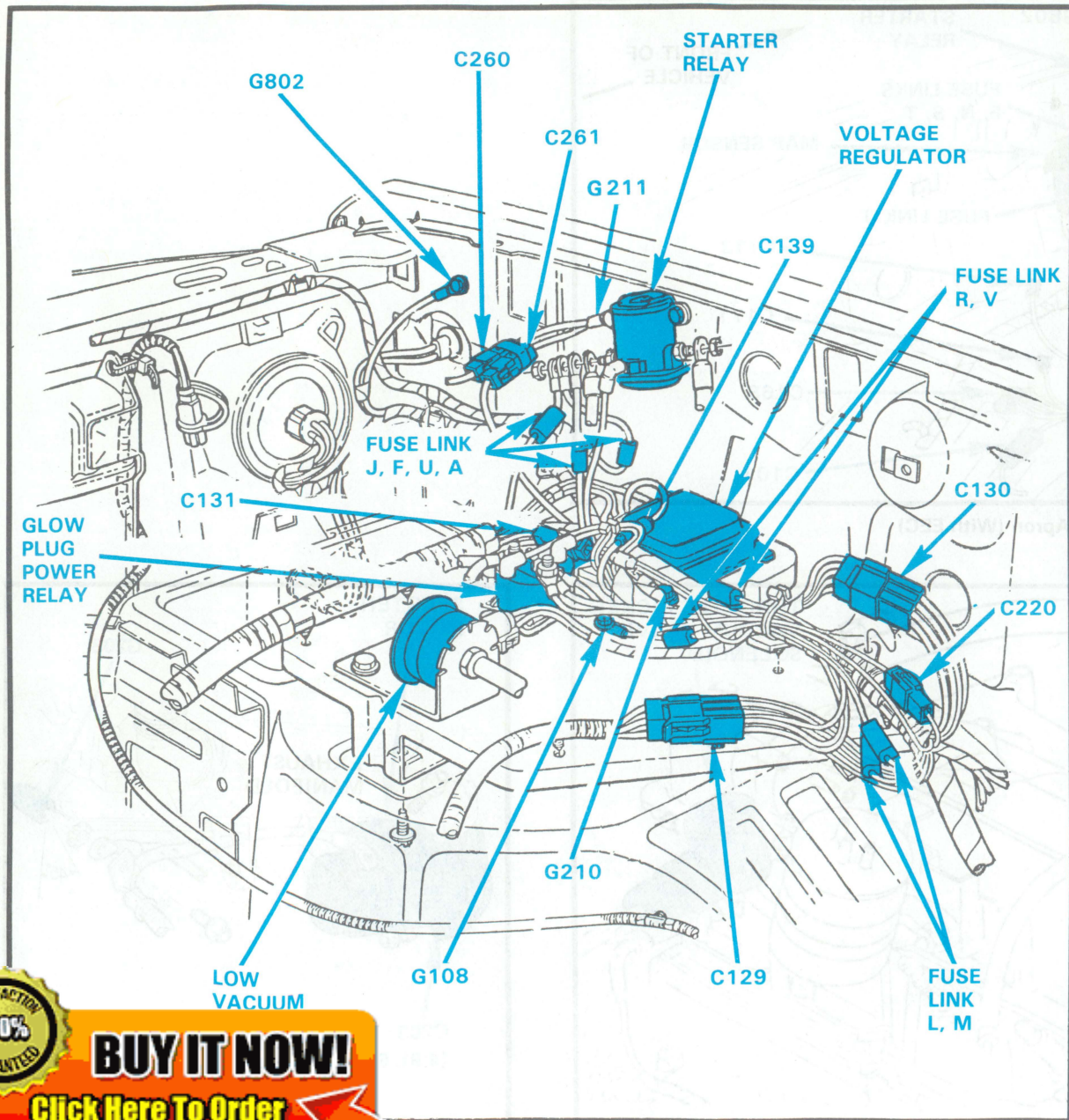

Figure 2 - Top Of RH Front Wheel Well (Gasoline Engine)

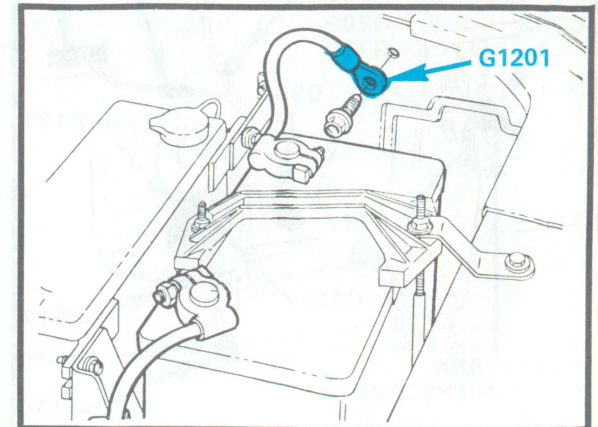



Figure 3 - Behind LH Headlamps

1 - RH Fender Apron (6.9L Diesel)

100% SATISFACTION GUARANTEED

BUY IT NOW!

Click Here To Order







100% SATISFACTION GUARANTEED

BUY IT NOW!

Click Here To Order

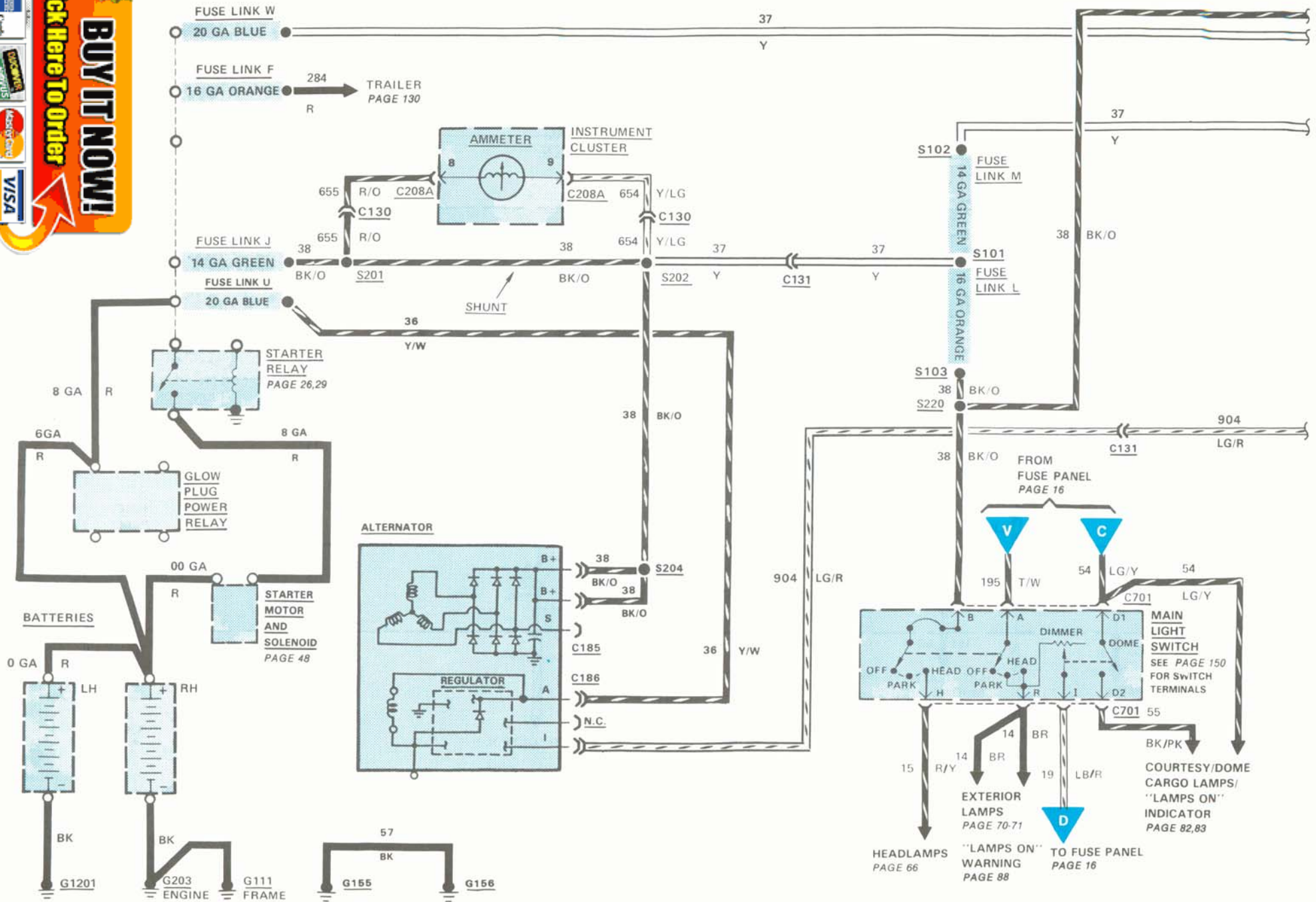

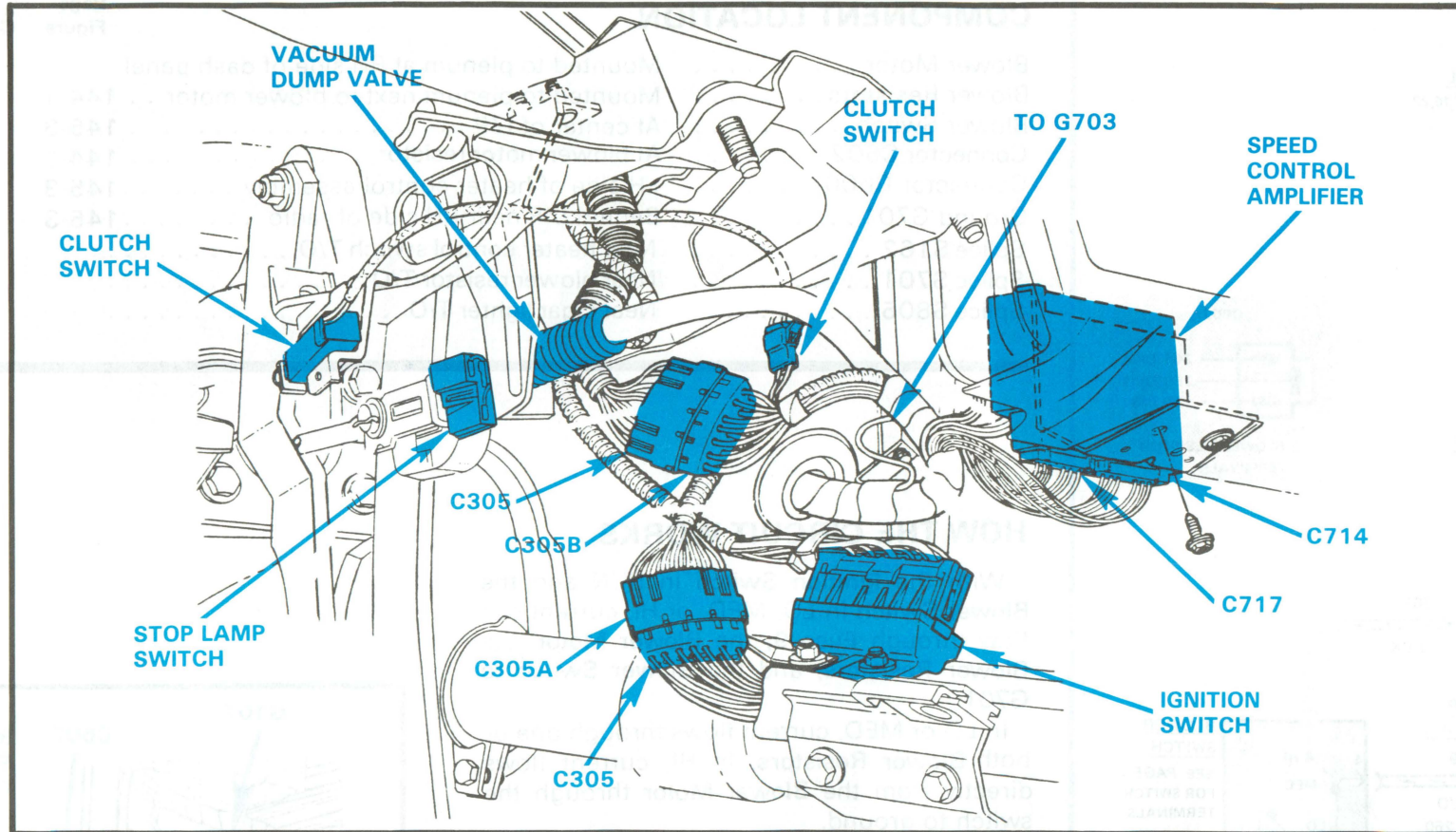
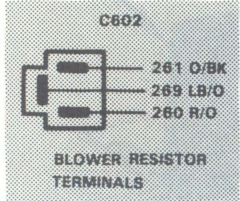
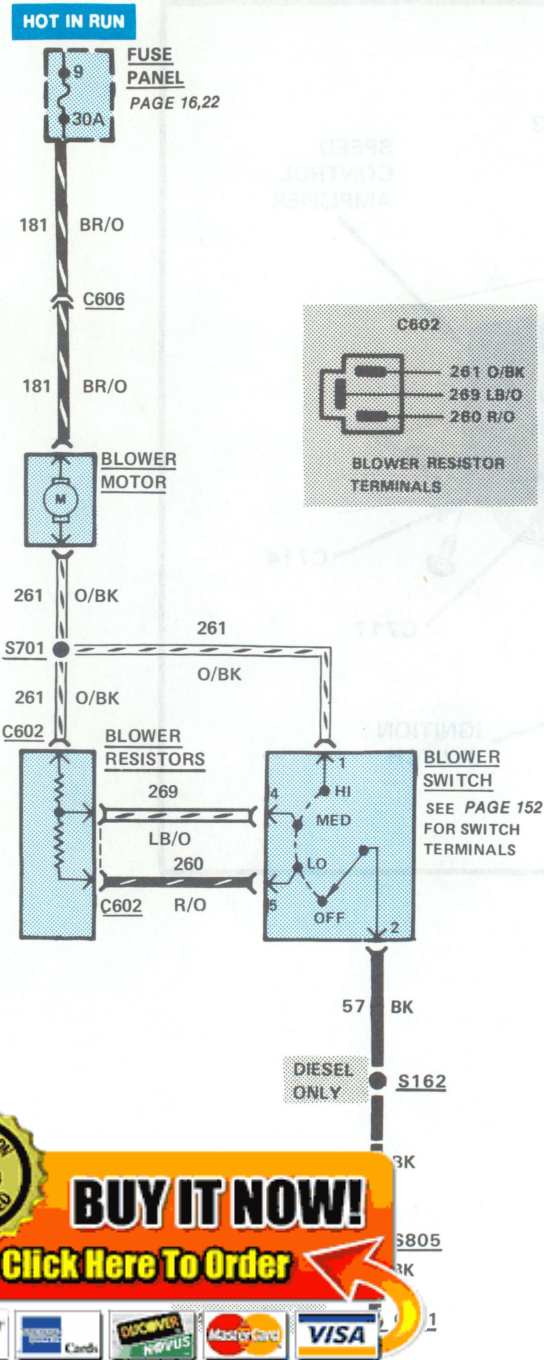

Figure 2— Under LH Side of I/P Next to Steering Column

100% SATISFACTION GUARANTEED

BUY IT NOW!

Click Here To Order



COMPONENT LOCATION

		Page-Figure	Color	Terminals
Blower Motor	Mounted to plenum at RH side of dash panel			
Blower Resistors	Mounted to plenum next to blower motor	144-1		
Blower Switch	At center of I/P	145-3		
Connector C602	At blower motor resistor	144-1	BK	3
Connector C606	LH side of heater control assembly	145-3	GY	1
Ground G701	Behind I/P near RH side of radio	145-3		
Splice S162	Near heater control switch T/O			
Splice S701	Near blower resistor T/O			
Splice S805	Near cigar lighter T/O			

HOW THE CIRCUIT WORKS

With the Ignition Switch in RUN and the Blower Switch in LO, MED, or HI, current can flow through Fuse 9, the Blower Motor, the Blower Resistors, and the Blower Switch to G701.

In LO or MED, current flows through one or both Blower Resistors. In HI, current flows directly from the Blower Motor through the switch to ground.

TROUBLESHOOTING HINTS

BLOWER DOESN'T WORK

- Check Fuse 9. Make sure G701 is clean and tight.
- Separate the O/BK wire at the Blower Motor. Check for continuity to ground (less than 3 ohms). If bad, check continuity of Blower Motor, Blower Resistors, and Blower Switch.
- Check Blower Switch for continuity, between pin 2 and pins 1, 4 and 5.
- Check all connectors for corrosion.

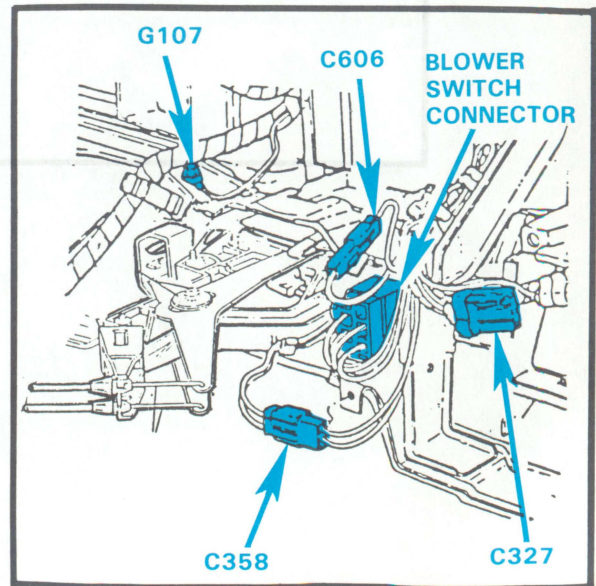

Figure 1 - Behind Center Of I/P

100% SATISFACTION GUARANTEED

BUY IT NOW!

Click Here To Order

PayPal, American Express, Discover, MasterCard, VISA

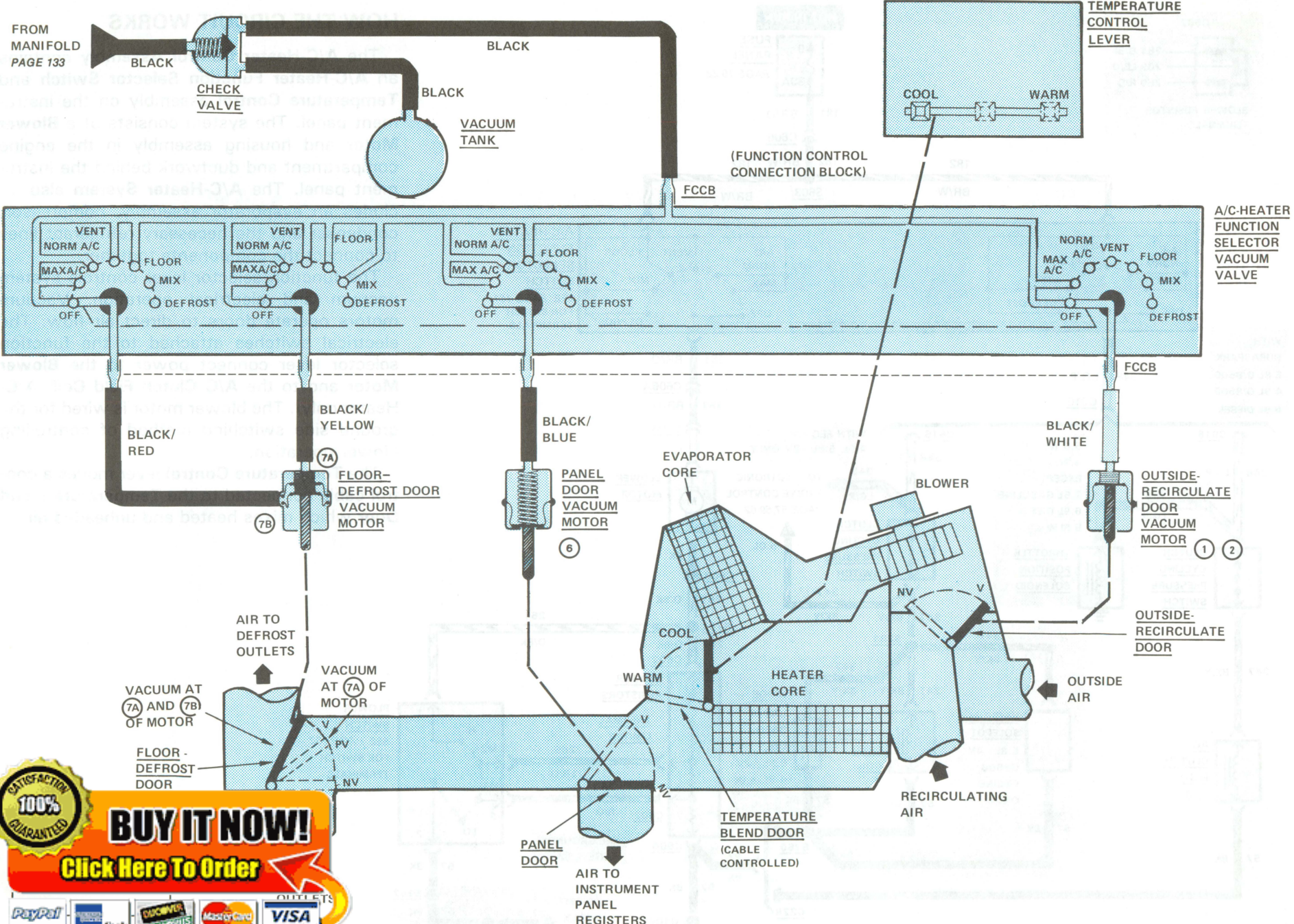

100% SATISFACTION GUARANTEED

BUY IT NOW!

Click Here To Order

PayPal, American Express, Discover, MasterCard, VISA

142 A/C HEATER (ELECTRICAL)

HOW THE CIRCUIT WORKS

The A/C-Heater Control Assembly contains an A/C-Heater Function Selector Switch and Temperature Control assembly on the instrument panel. The system consists of a **Blower Motor** and housing assembly in the engine compartment and ductwork behind the instrument panel. The **A/C-Heater System** also includes an evaporator assembly, compressor, condenser and the necessary refrigerant lines to connect the components together.

The function selector lever controls system vacuum and electrical operation. Vacuum motors operate doors to direct air flow. The electrical switches attached to the function selector lever connect power to the **Blower Motor** and to the **A/C Clutch Field Coil** (A/C-Heater only). The blower motor is wired for the ground side switching method of controlling blower operation.

The **Temperature Control** lever moves a control cable connected to the **Temperature Blend Door** which mixes heated and unheated air.

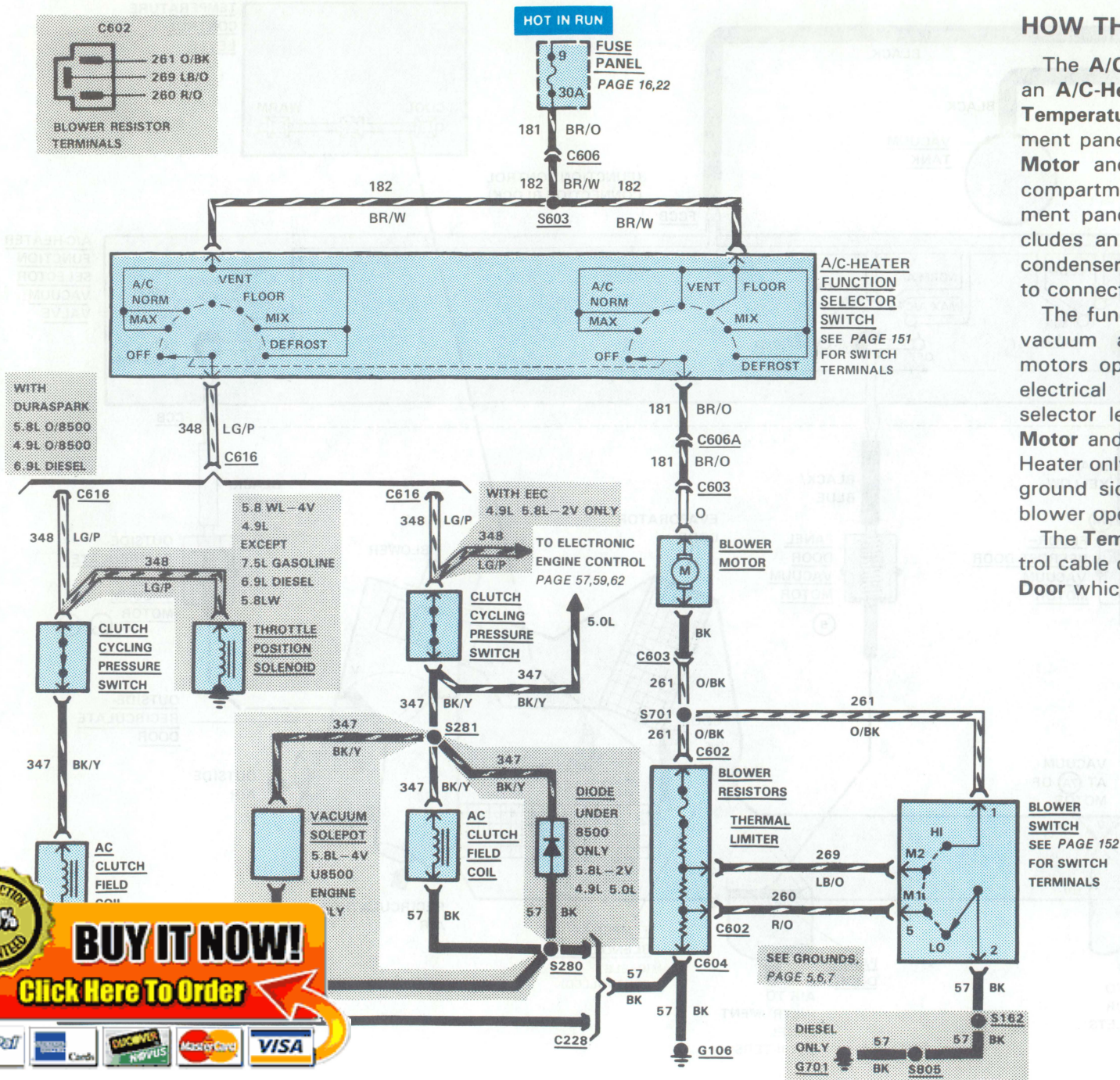

100% SATISFACTION GUARANTEED

BUY IT NOW!

Click Here To Order

HOW THE CIRCUIT WORKS

The **A/C-Heater System** contains a **Clutch Cycling Pressure Switch** attached to the suction accumulator assembly in the engine compartment. By sensing refrigerant pressure within the accumulator it controls the cycling of the **A/C Clutch Field Coil** to prevent the evaporator core from freezing and blocking air flow.

The **A/C-Heater System** may contain a **Throttle Positioner Solenoid** which increases engine idle speed when the **A/C Clutch Field Coil** is energized.

LEVER POSITIONS AND OPERATION

A/C-Heater

— **OFF** Vacuum is applied to the **Outside Recirculate Door Vacuum Motor**, closing that door to outside air. The **Blower Motor** does not operate. No air passes through the system. The **Blower Motor** does operate in all other positions of the **Function Selector** lever.

— **MAX A/C.** The **Outside-Recirculate Door** closes to outside air. The **Floor/Defrost Door** closes the defroster outlets (vacuum at A and B on motor) and the **Panel Door** sends air to the instrument panel registers (vacuum on motor). With the **Temperature Control** at COOL, the **Temperature Blend Door** moves to the COOL position. No air flows through the heater core. The **A/C Clutch Field Coil** is energized through the **Clutch Cycling Pressure Switch** for compressor operation.

— **NORM A/C.** The **Outside-Recirculate Door** is open to outside air. The **Panel Door** directs air to the instrument panel registers. The **A/C**

COMPONENT LOCATION

		Page-Figure	Color	Terminals
A/C Clutch Field Coil	Part of compressor	145-4		
Blower Motor	Mounted to plenum at RH side of dash panel			
Blower Switch	At center of I/P	145-3		
Blower Resistors	Mounted to plenum next to blower	144-1		
Clutch Cycling Pressure Switch	RH side of dash panel on accumulator	144-1	GY	1
Connector C228	Near accumulator/drier	144-1	BL	3
Connector C602	At blower motor resistor	144-1	GY	2
Connector C603	At blower motor	144-1	BK	1
Connector C604	At blower motor resistor	144-1	GY	1
Connector C606	LH side of function control	145-3	GY	1
Connector C606A	LH side of function control	145-3	W	1
Connector C616	Near evaporator accumulator	144-1		
Ground G106	Behind I/P near RH side of radio	145-3		
Ground G701	Behind I/P near RH side of radio	145-3		
Splice S162	Near heater control switch T/O diesel only			
Splice S280	Near A/C clutch T/O			
Splice S281	Near A/C clutch T/O			
Splice S603	Near A/C mode switch T/O			
Splice S701	Near blower resistor T/O			
Splice S805	Near cigar lighter T/O			

— **VENT.** The **Outside-Recirculate Door** is open to outside air, as in normal A/C. Vacuum is applied to the **Panel Door Vacuum Motor**, letting air flow only to the instrument panel registers. In the same way, the defroster outlets are closed by the **Floor/Defrost Vacuum Motor**. The A/C clutch field coil is not energized.

— **FLOOR.** The **Outside-Recirculate Door** is open to outside air. With no vacuum at the **Panel Door Vacuum Motor**. The **Panel Door** directs air to the floor outlets. The **A/C Clutch Field Coil** does not operate.

— **MIX.** Vacuum is applied only to port A of the **Floor/Defrost Vacuum Motor** positioning the **Floor/Defrost Door** at mid-position. Air flow is split between the floor and the windshield. There is no vacuum at the **Panel Door Vacuum Motor**. This closes the instrument panel registers. The A/C clutch field coil is energized.

— **DEFROST.** With no vacuum at any vacuum motor, air flows to the defroster outlets. The A/C clutch field coil is energized.

100% SATISFACTORY GUARANTEED

BUY IT NOW!

Click Here To Order



TROUBLESHOOTING HINTS

BLOWER DOESN'T WORK

- Check **Fuse 9**. Make sure **G106** and **G701** are clean and tight.
- Separate the **Blower Motor Switch Connector**. Set **Function Selector** to OFF position. Check for continuity to ground (less than 3 ohms) at all terminals of harness connector. If bad, check continuity of **Blower Motor** and **Blower Resistors**.
- With **Function Selector Lever** in any position except OFF, check for **Battery** voltage at BR/O wire at **C606A**.

COMPRESSOR CLUTCH DOESN'T WORK

- With **Ignition Switch** in RUN and **Function Selector** in A/C MAX or NORM, check for voltage at **A/C Clutch Field Coil**. Check **Fuse 9**.
- Remove connector at **A/C Clutch Field Coil**. Check for continuity through clutch field coil. Check continuity to ground at **57 BK** wire.
- Separate connector at **Clutch Cycling Pressure Switch**. Check continuity through switch. No continuity may indicate system is low or out of R-12 refrigerant.
- Check circuit continuities. Check all connectors for corrosion.

HISSING: AIR FLOW FROM WRONG OUTLETS, OTHER VACUUM PROBLEMS

- Refer to Vacuum Schematic. Check for vacuum system leak or bad motor. Read "How to Find the Vacuum Problem" on page

NO COOLING OR NOT ENOUGH COOLING

- Check A/C compressor drive belt tension.
- Be sure door vacuum motors don't stick.
- Check temperature control cable for

proper adjustment.

- See Section 36 of Shop Manual for Refrigerant System diagnosis.

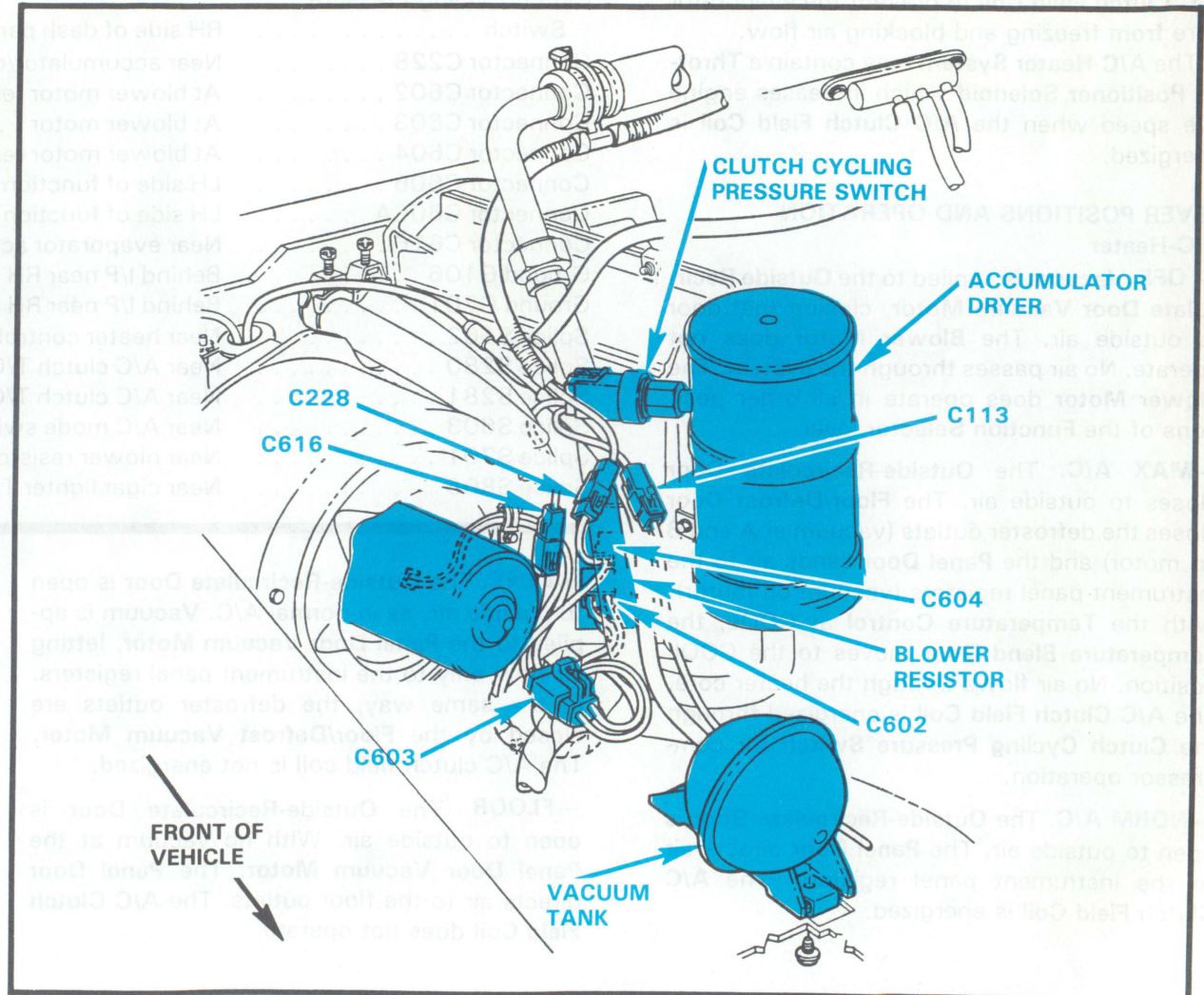

Figure 1 – RH Dash With Air Conditioning

100% SATISFACTION GUARANTEED

BUY IT NOW!

Click Here To Order

in the Shop

PayPal American Express Discover Novus MasterCard VISA

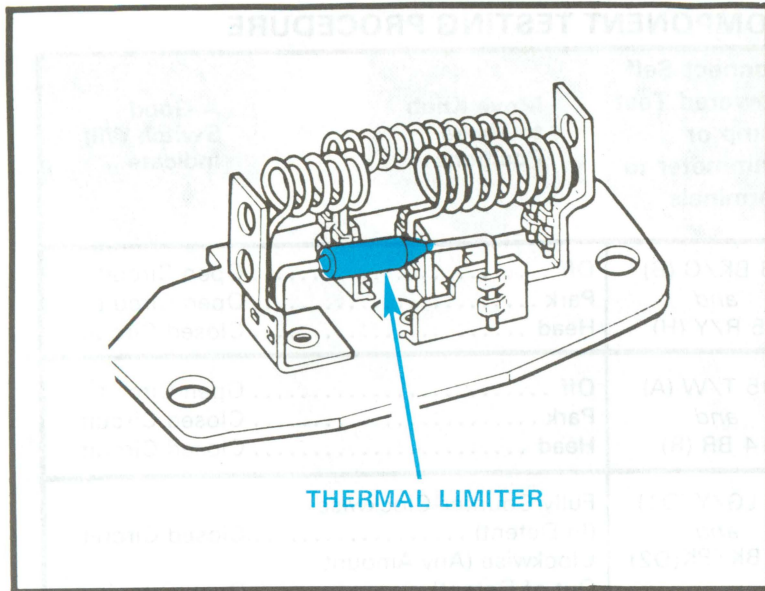

Figure 2 — Blower Resistor Assembly

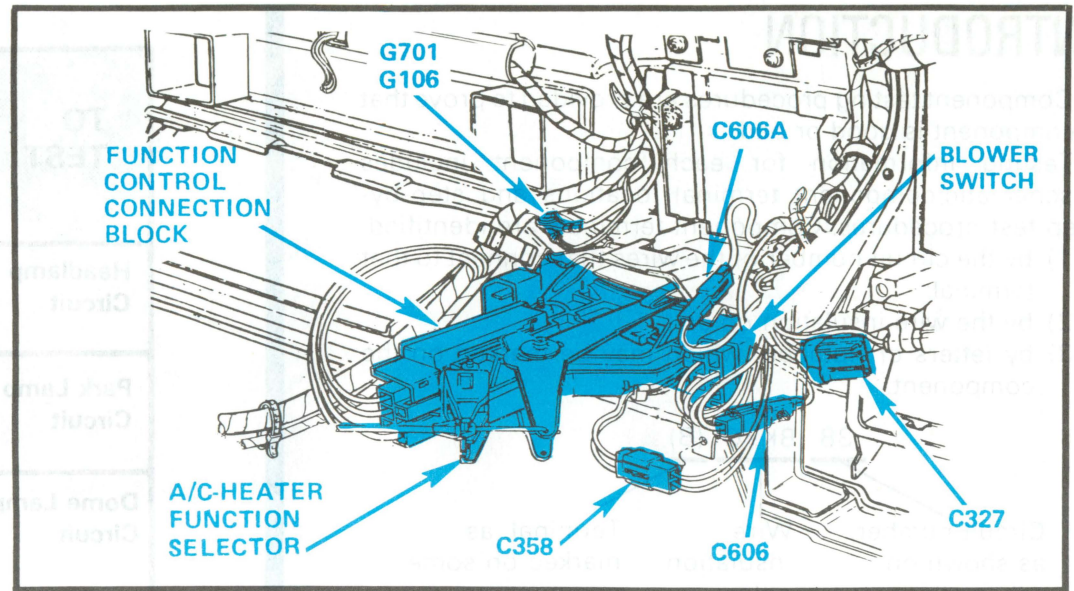

Figure 3 — Behind Center Of I/P (A/C And Heater)



100% SATISFACTION GUARANTEED

BUY IT NOW!

Click Here To Order

Old Coil



INTRODUCTION

Component testing procedures are provided to prove that a component is good or bad.

Testing information for each component includes a schematic, component terminal locations and step-by-step test procedures. Component terminals are identified:

- 1) by the circuit number of the wires that connect to that terminal;
- 2) by the wire insulation color;
- 3) by letters or numbers which may be marked on the component.

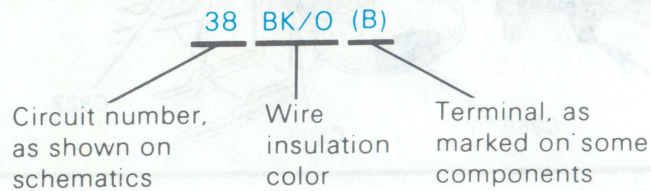

The component connector **MUST BE REMOVED** before testing. To test a single circuit within the component, select that circuit under the column **TO TEST**. If you wish to test the complete component, perform all tests.

Connect the tester to the terminals shown in the second column and operate the component as shown in the third column.

MAIN LIGHT SWITCH

SCHMATIC

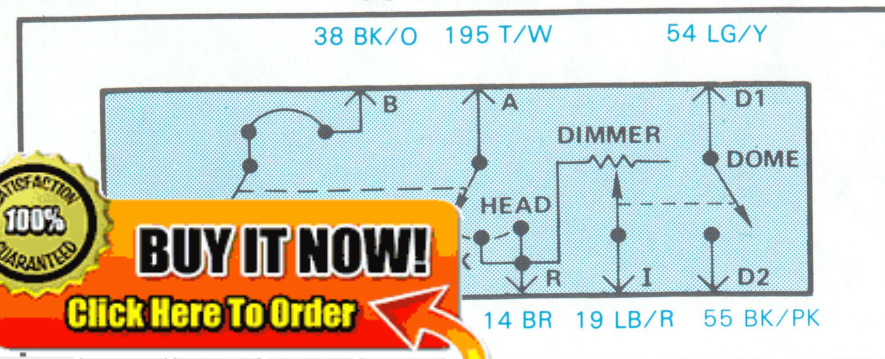

100% SATISFACTION GUARANTEED

BUY IT NOW!

Click Here To Order

COMPONENT TESTING PROCEDURE

TO TEST	Connect Self Powered Test Lamp or Ohmmeter to Terminals	Move Knob to These Positions	A Good Switch Will Indicate
Headlamp Circuit	38 BK/O (B) and 15 R/Y (H)	Off Park Head	Open Circuit Open Circuit Closed Circuit
Park Lamp Circuit	195 T/W (A) and 14 BR (R)	Off Park Head	Open Circuit Closed Circuit Closed Circuit
Dome Lamp Circuit	54 LG/Y (D1) and 55 BK/PK (D2)	Fully Counter-Clockwise (In Detent) Clockwise (Any Amount Out of Detent)	Closed Circuit Open Circuit
Panel Lamp Dimmer Circuit	14 BR (R) and 19 LB/R (I)	Rotate Knob Clockwise	Ohmmeter Will Show Smoothly Increasing Resistance

TERMINAL LOCATIONS ON SWITCH

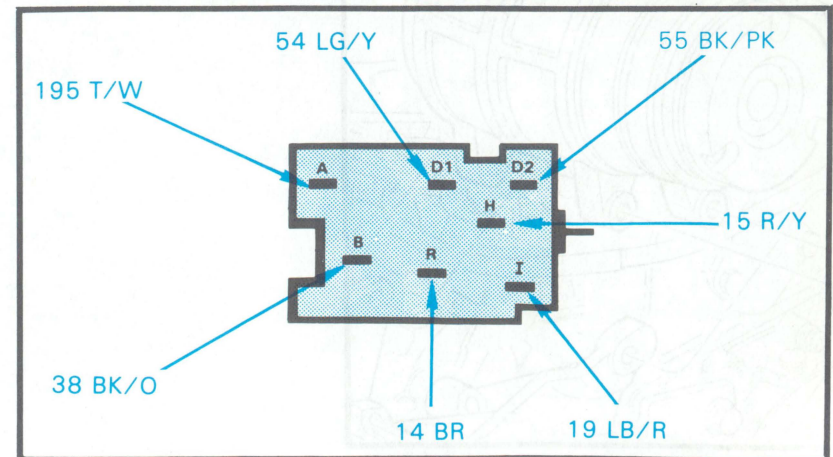

COMPONENT TESTING PROCEDURE

TO TEST	Connect Self Powered Test Light or Ohmmeter to Terminals	Move Key to These Positions	A Good Switch Will Indicate
Internal Switch Connections (perform these tests first)	37 Y (BATT) and 37 Y (BATT)	Accy, Lock, Off, Run, Start	Closed Circuit in all five positions
	687 GY/Y (A2) and 687 GY/Y (A2)	Accy, Lock, Off, Run, Start	Closed Circuit in all five positions
Starter Relay Circuit	37 Y (BATT) (either terminal) and 32 R/L B (ST)	Accy, Lock, Off, Run, Start	Closed Circuit in Start position only
A/C, Heater Circuit, Turn/Stop Lamps, Backup Lamps	37 Y (BATT) (either terminal) and 687 GY/Y (A2) (either terminal)	Accy, Lock, Off, Run, Start	Closed Circuit in Run position only

COMPONENT TESTING PROCEDURE

TO TEST	Connect Self Powered Test Light or Ohmmeter to Terminals	Move Key to These Positions	A Good Switch Will Indicate
Ignition Circuit	37 Y (BATT) (either terminal) and 16 R/LB and 20 W/LB (I1)	Accy, Lock, Off, Run, Start	Closed Circuit in Run. May be open or closed in Start position.
	37 Y (BATT) (either terminal) and 16 R/LB and 262 BR/PK (I2)	Accy, Lock, Off, Run, Start	Closed Circuit in Start position only
"Accy" Circuit	37 Y (BATT) (either terminal) and 297 BK/LG (A1)	Accy, Lock, Off, Run, Start	Closed Circuit in Run and Accy position only
Bulb-Test Circuit	41 BK/LB or 977 P/W (P1) and Ignition Switch Case	Accy, Lock, Off, Run, Start	Closed Circuit in Start position only
	977 P/W (P2) and Ignition Switch Case	Accy, Lock, Off, Run, Start	Closed Circuit in Start position only

TERMINAL LOCATIONS



SCHEMATIC

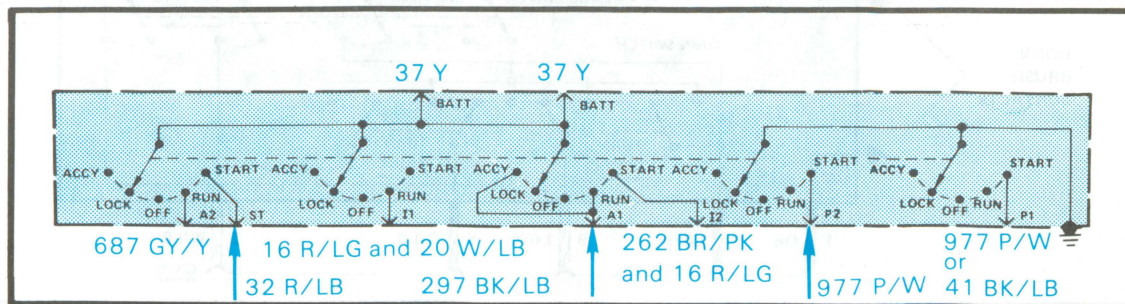

148 COMPONENT TESTING: TURN/HAZARD SWITCH

COMPONENT TESTING PROCEDURE

TO TEST	Connect Self Powered Test Light or Ohmmeter to Terminals	Move Switch to These Positions	A Good Switch Will Indicate
Horn Switch Circuit	460 Y/LB and 1 DB	Depress Horn Switch (If removed from truck, jumper brush contacts)	Closed Circuit.
LH Rear Turn Circuit	44 LB and 9 LG/O	Turn Switch to Turn Left and Hazard Switch to Normal	Closed Circuit
LH Front Turn Circuit	44 LB and 3 LG/W	Turn Left	Closed Circuit
RH Rear Turn Circuit	44 LB and 5 O/LB	Turn Right	Closed Circuit
RH Front Turn Circuit	44 LB and 2 W/LB	Turn Right	Closed Circuit

COMPONENT TESTING PROCEDURE

TO TEST	Connect Self-Powered Test Light or Ohmmeter to Terminals	Move Switch to These Positions	A Good Switch Will Indicate
Hazard Switch Circuit	385 W/R and 511 LG	Hazard	Closed Circuit
	385 W/R and 2 W/LB	Hazard	Closed Circuit
	385 W/R and 3 LG/W	Hazard	Closed Circuit
Stop Lamp Feed-Through Circuit	511 LG and 9 LG/O	Turn Switch to center (No Turn) position or Turn Right	Closed Circuit
	511 LG and 5 O/LB	Turn Switch to center (No Turn) position or Turn Left	Closed Circuit

SCHEMATIC

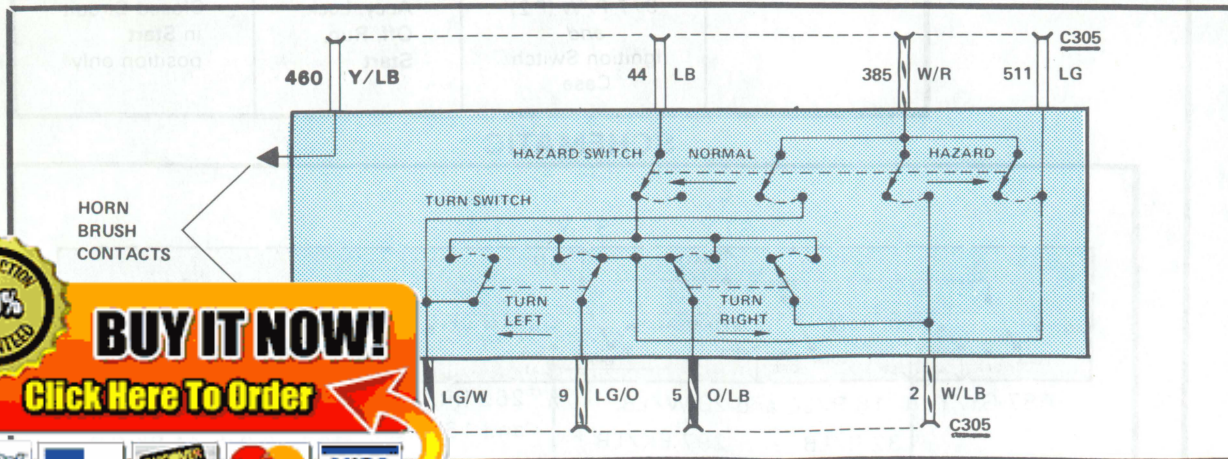

TERMINAL LOCATIONS

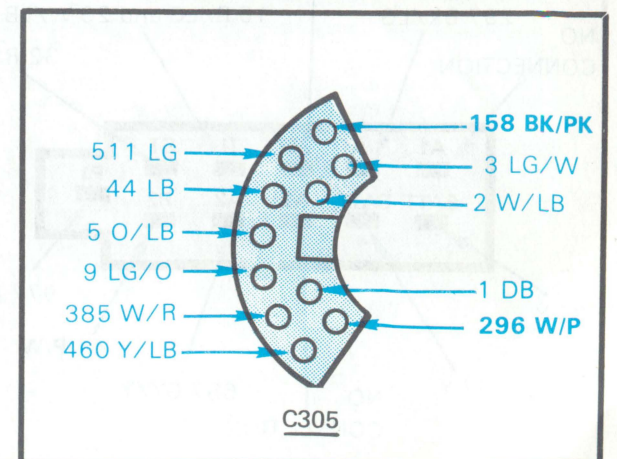

BUY IT NOW!

[Click Here To Order](#)



TERMINAL LOCATIONS ON SWITCH

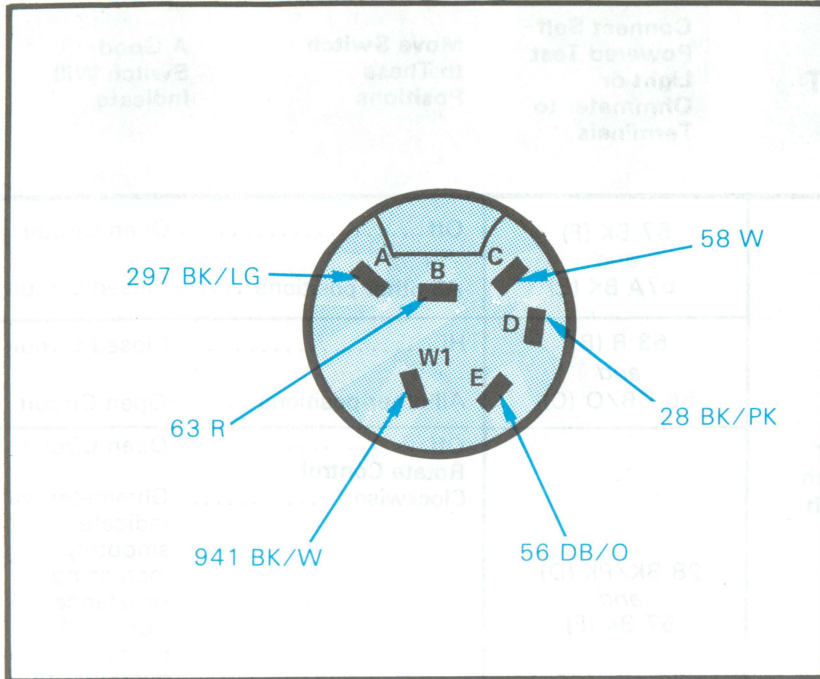

COMPONENT TESTING PROCEDURE

TO TEST	Connect Self-Powered Test Light or Ohmmeter to Terminals	Move Switch to These Positions	A Good Switch Will Indicate
Washer Switch Circuit	941 BK/W (W) and 63 R (B)	Push knob Release knob	Closed Circuit Open Circuit
Wiper Switch Circuit	63 R (B) and 58 W (C)	Off Lo Hi	Open Circuit Closed Circuit Open Circuit
	63 R (B) and 56 DB/O (E)	Off Lo Hi	Open Circuit Open Circuit Closed Circuit
	58 W (C) and 28 BK/PK (D)	Off Lo Hi	Closed Circuit Open Circuit Open Circuit
Circuit Breaker	297 BK/LG (A) and 63 R (B)	All positions	Closed Circuit

SCHEMATIC

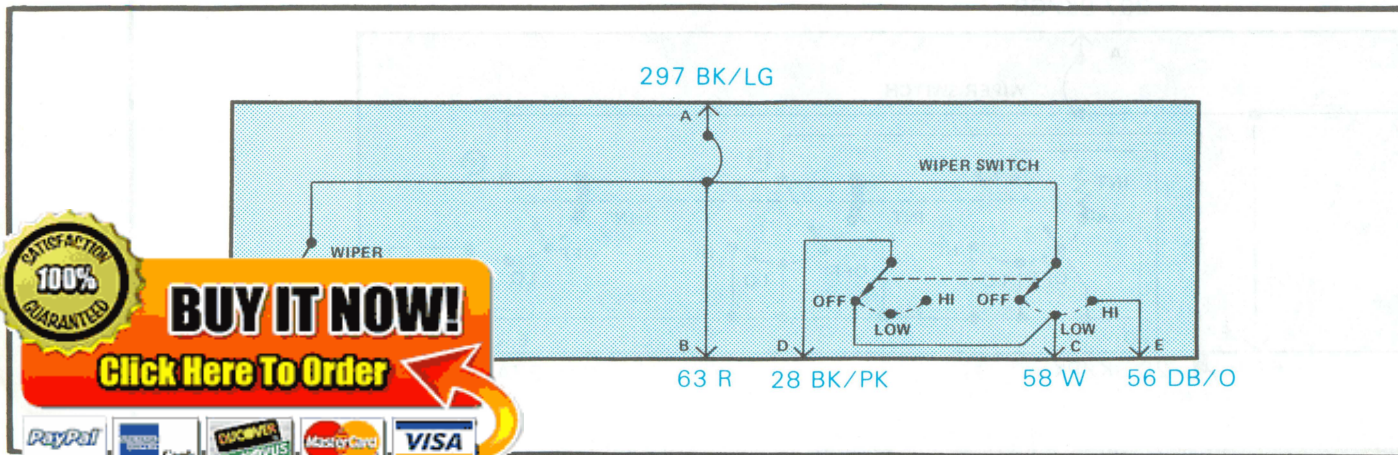

BUY IT NOW!

Click Here To Order



150 COMPONENT TESTING: INTERVAL WIPER/WASHER SWITCH

TERMINAL LOCATIONS ON SWITCH

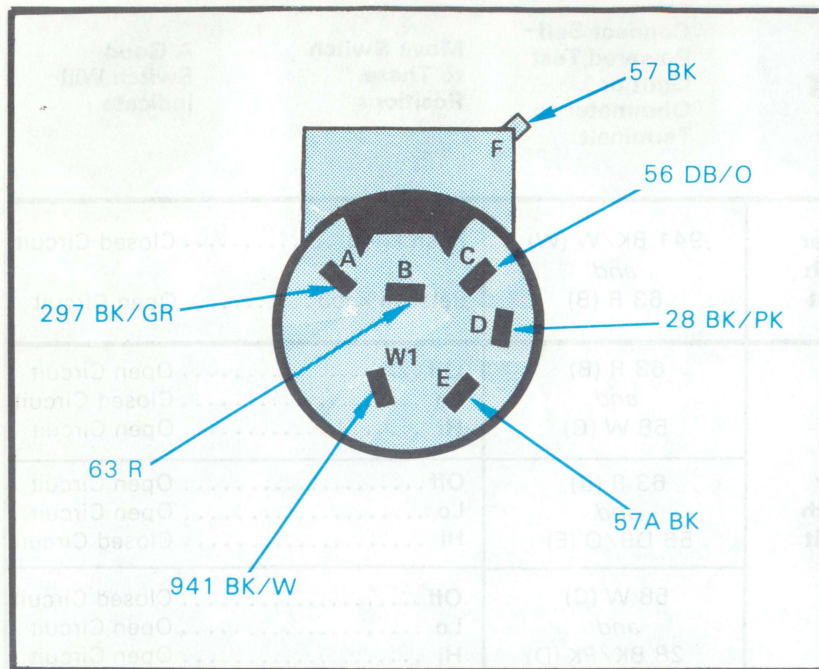

SEE PAGE 100 FOR WASHER SWITCH CIRCUIT AND CIRCUIT BREAKER TESTS

SCHEMATIC

COMPONENT TESTING PROCEDURE

TO TEST	Connect Self-Powered Test Light or Ohmmeter to Terminals	Move Switch to These Positions	A Good Switch Will Indicate
Wiper Switch Circuit	57 BK (F) and 57A BK (E)	Off	Open Circuit
	63 R (B) and 56 DB/O (C)	All other positions	Closed Circuit
	28 BK/PK (D) and 57 BK (F)	Off Rotate Control Clockwise	Open Circuit Ohmmeter will indicate smoothly increasing resistance from 200 ohms minimum to 8400 ohms maximum
		All other positions	Closed Circuit

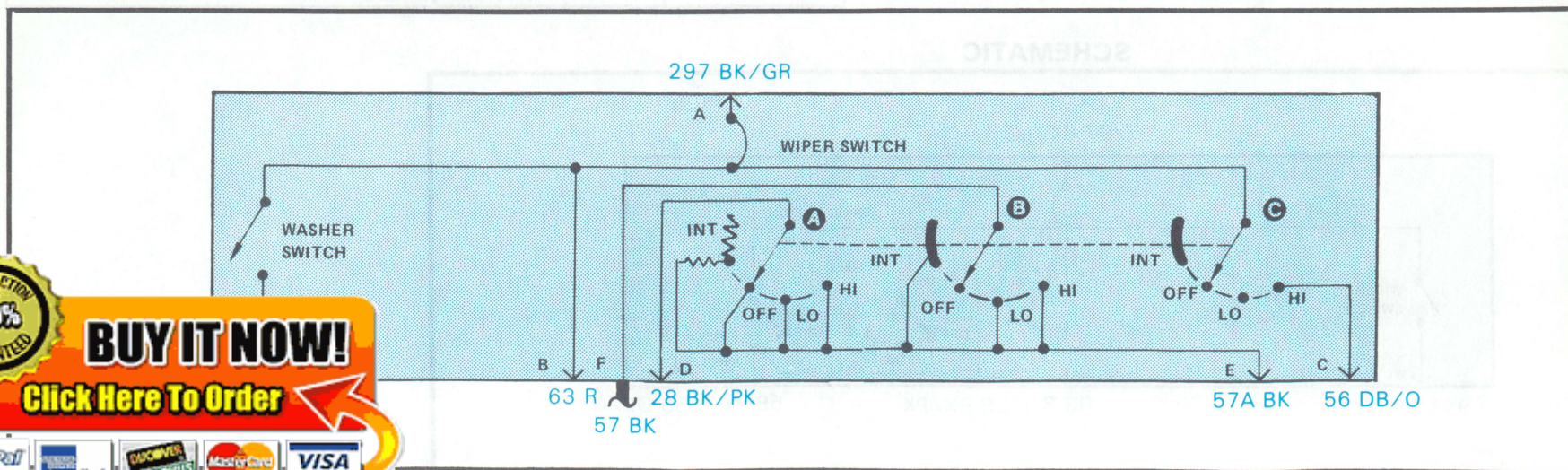

100% SATISFACTION GUARANTEED

BUY IT NOW!

[Click Here To Order](#)

TERMINAL LOCATIONS ON SWITCH

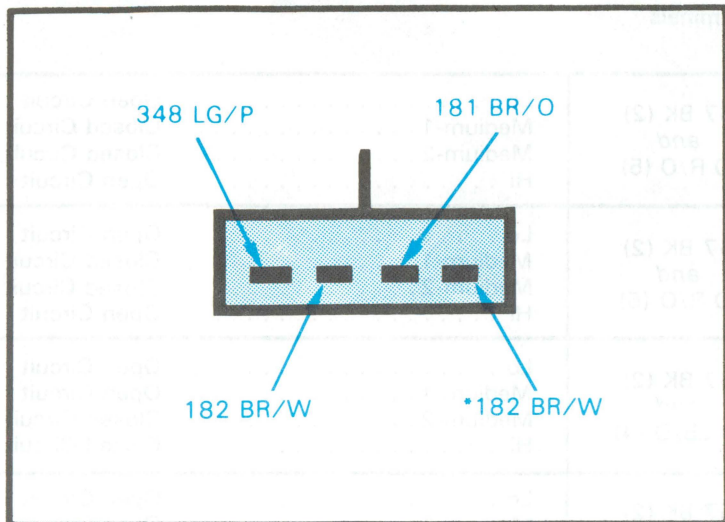

COMPONENT TESTING PROCEDURE

TO TEST	Connect Self Powered Test Light or Ohmmeter to Terminals	Move Control to These Positions	A Good Switch Will Indicate
A/C Clutch Circuit	182 BR/W and 348 LG/P	Off A/C Max A/C Norm Vent Floor Mix Defrost	Off Open Circuit A/C Max Closed Circuit A/C Norm Closed Circuit Vent Open Circuit Floor Open Circuit Mix Closed Circuit Defrost Closed Circuit
Blower Motor Circuit	*182 BR/W and 181 BR/O	Off	Off Open Circuit All other positions Closed Circuit

SCHEMATIC

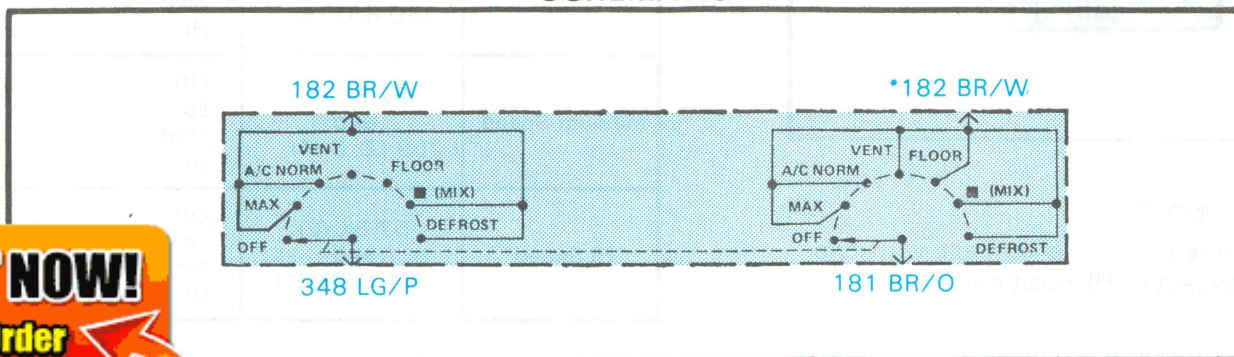

100% SATISFACTION GUARANTEED

BUY IT NOW!

Click Here To Order

152 COMPONENT TESTING: BLOWER SWITCH

TERMINAL LOCATIONS ON SWITCH

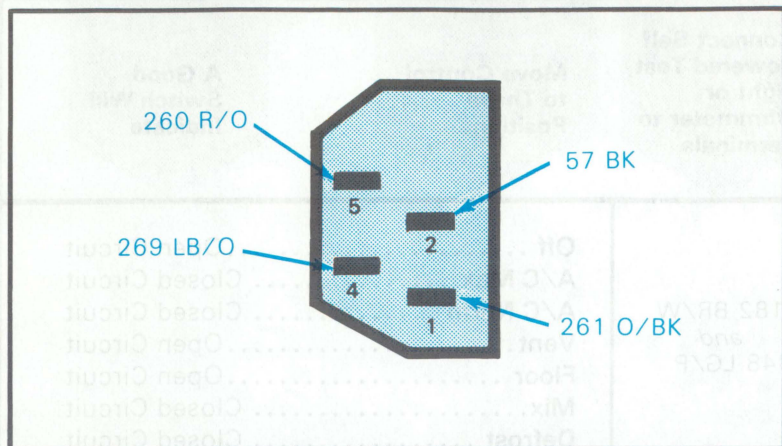

SCHEMATIC

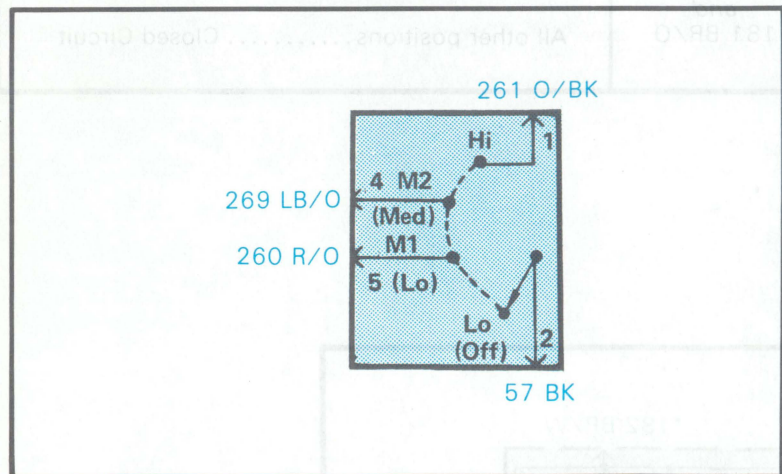

NOTE:

to make contact with two in HI position.

COMPONENT TESTING PROCEDURE—WITH A/C

TO TEST	Connect Self-Powered Test Light or Ohmmeter to Terminals	Move Switch to These Positions	A Good Switch Will Indicate
Lo Speed (Lo)	57 BK (2) and 260 R/O (5)	Lo Medium-1 Medium-2 Hi	Open Circuit Closed Circuit Closed Circuit Open Circuit
Medium-Low Speed (M1)	57 BK (2) and 260 R/O (5)	Lo Medium-1 Medium-2 Hi	Open Circuit Closed Circuit Closed Circuit Open Circuit
Medium-High Speed (M2)	57 BK (2) and 269 LB/O (4)	Lo Medium-1 Medium-2 Hi	Open Circuit Open Circuit Closed Circuit Closed Circuit
Hi Speed	57 BK (2) and 261 O/BK (1)	Lo Medium-1 Medium-2 Hi	Open Circuit Open Circuit Open Circuit Closed Circuit

COMPONENT TESTING PROCEDURE—WITHOUT A/C

Lo Speed	57 BK (2) and 260 R/O (5)	Off Lo Med Hi	Open Circuit Closed Circuit Closed Circuit Open Circuit
Medium Speed	57 BK (2) and 269 LB/O (4)	Off Lo Med Hi	Open Circuit Open Circuit Closed Circuit Closed Circuit
Hi Speed	57 BK (2) and 261 O/BK (1)	Off Lo Med Hi	Open Circuit Open Circuit Open Circuit Closed Circuit

100% SATISFACTION GUARANTEED

BUY IT NOW!

Click Here To Order



**WE SUPPORT VOLUNTARY
TECHNICIAN CERTIFICATION**



**Ford Parts and Service Division
Training and Publications Department**

100% SATISFACTION GUARANTEED

BUY IT NOW!

Click Here To Order 

0336-521-86