

1985 MUSTANG/ CAPRI

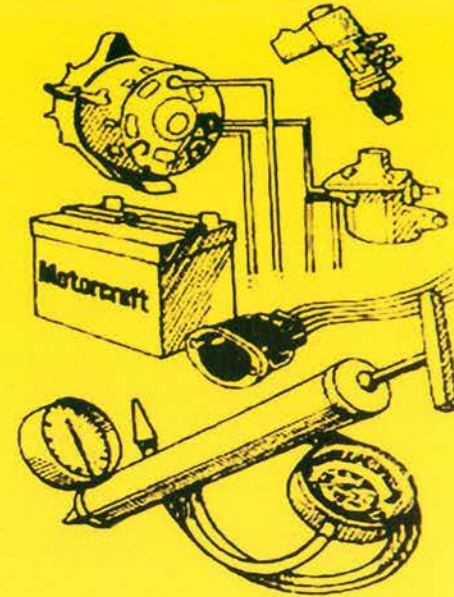

Electrical & Vacuum Trouble-Shooting Manual



DEMO

This DEMO contains only a few pages of the entire manual/product.

Not all Bookmarks work on the Demo, but they do on the full version.

Features:

- Searchable text
- Printable pages
- Bookmarked for easy navigation
- High Resolution images
- Zoom to see exact details
- Money back Guarantee
- Available on USB and eBook download

100% SATISFACTION GUARANTEED

BUY IT NOW!

Click Here To Order

Ford

Official
Licensed
Product

License #84356800

Copyright © 2023, Forel Publishing Company, LLC, Woodbridge, Virginia

All Rights Reserved. No part of this book may be used or reproduced in any manner whatsoever without written permission of Forel Publishing Company, LLC. For information write to Forel Publishing Company, LLC, Woodbridge, VA 22192

**1985 Mustang / Capri Electrical & Vacuum Trouble-
Shooting Manual (EVTM)
EAN: 978-1-60371-396-2
ISBN: 1-60371-396-4**

Forel Publishing Company, LLC
Woodbridge, VA 22192
Email: sales@ForelPublishing.com
<https://www.ForelPublishing.com>



This publication contains material that is reproduced and distributed under a license from Ford Motor Company. No further reproduction or distribution of the Ford Motor Company material is allowed without the express written permission of Ford Motor Company.

Note from the Publisher

This product was created from the original Ford Motor Company's publication. Every effort has been made to use the original scanned images, however, due to the condition of the material; some pages have been modified to remove imperfections.

Disclaimer

Although every effort was made to ensure the accuracy of this book, no representations or warranties of any kind are made concerning the accuracy, completeness or suitability of the information, either expressed or implied. As a result, the information contained within this book should be used as general information only. The author and Forel Publishing Company, LLC shall have neither liability nor responsibility to any person or entity with respect to any loss or damage caused, or alleged to be caused, directly or indirectly by the information contained in this book. Further, the publisher and author are not engaged in rendering legal or other professional services. If legal, mechanical, electrical, or other expert assistance is required, the professional should be sought.



How to Use This Manual 1
 How to Find the Electrical Problem 2
 Symbols (Electrical) 4
 (Vacuum) 70
 How to Find the Vacuum Problem 71
 Component Testing
 Introduction 79
 Light Switch 79
 Ignition Switch 80
 Multi-Function Switch 81
 Windshield Wiper/Washer Switch 82
 Interval Wiper/Washer Switch 83
 A/C-Heater Function Control 84
 A/C-Heater Blower Switch 85
 Instrument Panel (Back View) 89
 • • • • •
 A/C-Heater 74
 Altitude Air Bleed 132
 Brake Warning Indicator 46
 Charge 10
 Choke Heater 10
 Cigar Lighter 52
 Clock 52
 Compressor Clutch Control 136, 90, 92
 Convertible Top 125
 Coolant Temperature Gage 48
 Cooling Fan Control 90, 92
 Electronic Engine Control (EEC) 103
 Electronic Radio (Premium Sound) 127
 Fuel Filler Door Release 23
 Fuel Gage 48
 Fuse Block 9
 Gages 48
 Graphic Warning Module 50
 Grounds 138, 6, 26, 19
 Heater 78
 52
 14, 98
 44, 48
 44
 42
 59

Light Out Warning 50, 58
 Lights
 Backup 41
 Brake Indicator 46
 Clock 44
 Courtesy 42
 Dome/Map 43
 Exterior 34
 Fog 134
 Glove Box 42
 Hazard 38
 Headlights 32
 Instrument Illumination 44
 License 36
 Map 43
 Marker 34, 36
 Park 34
 Radio Illumination 44
 Rear Park (Tail) 36
 Stop 38, 40
 Turn 38, 40
 Light Switch 12
 Low Fuel Warning 48
 Power Distribution 10
 Power Door Locks 60
 Power Windows 62
 Printed Circuit Board Connector (RH) 44
 (LH) 48
 Radio (Mono) 64
 (Stereo/Tape) 65
 (Premium Sound) 66
 Rear Window Defrost 24
 Restart Choke Control 28
 Seatbelt Warning 46
 Speed Control 72
 Start 14, 98
 Tachometer 14
 Trunk Release 59
 Turbo Indicators 118
 Two-Speed Accessory Drive 130
 Upshift Indicator 30, 128
 Vacuum Distribution 69, 120
 Warning Indicators 46

IMPORTANT SAFETY NOTICE

Appropriate service methods and proper repair procedures are essential for the safe, reliable operation of all motor vehicles, as well as the personal safety of the individual doing the work. This Manual provides general directions for accomplishing service and repair work with tested, effective techniques. Following them will help assure reliability.

There are numerous variations in procedures, techniques, tools, and parts for servicing vehicles, as well as in the skill of the individual doing the work. This Manual cannot possibly anticipate all such variations and provide advice or cautions as to each. Accordingly, anyone who departs from the instructions provided in this Manual must first establish that he compromises neither his personal safety nor the vehicle integrity by his choice of methods, tools or parts.

Windshield Wiper/Washer 54
 Wiper/Washer (Interval) 56

100% GUARANTEED
BUY IT NOW!
 Click Here To Order

The purpose of this manual is to show electrical and vacuum circuits of these vehicles in a clear and simple fashion to make troubleshooting easier. With each circuit is a description of *How the Circuit Works* and some *Troubleshooting Hints*. A *Component Location* chart lists components, connectors, and references to pictures in the manual.

Wiring Diagrams give a schematic picture of when and how the circuit is powered, what the current path is to circuit components, and how the circuit is grounded. Each circuit component is named (underlined titles). Wire and connector colors are listed (standard Ford color abbreviations are used):

COLOR ABBREVIATIONS

BL	Blue	N	Natural
BK	Black	O	Orange
BR	Brown	PK	Pink
DB	Dark Blue	P	Purple
DG	Dark Green	R	Red
GR	Green	T	Tan
GY	Gray	W	White
LB	Light Blue	Y	Yellow
LG	Light Green		

Where two colors are shown for a wire, the first color is the basic color of the wire. The second color is the dot, hash, or stripe marking. If **D** or **H** is given, the second color is dots or hash marks. If there is no letter after the second color, the wire has a stripe.

For example:

BR/O is a brown wire with an orange stripe.
BR/OH is a brown wire with orange hash marks.
BR/O is a brown wire with an orange stripe.
BR/OH is a brown wire with orange hash marks.

Connector end views of switches and other components are shown to help with bench testing. The views show the harness wire colors that connect to the mating terminals. Connector colors and locations are shown in the *Component Location* chart. Two-color listings indicate separate colors for each connector half.

Components which work together are shown together. For example, all electrical components used in any circuit are shown on one diagram. The circuit breaker or fuse is shown at the top of the page. All wires, connectors, splices, switches, and motors are shown in the flow of current to ground at the bottom of the page. Notes are included which describe how switches and other components work. If a component is used in several different circuits, it is shown in several places. For example, the **Light Switch** is an electrical part of many circuits and is repeated on many pages. In some cases, however, a component may seem by its name to belong on a page where it has no electrical connection. For example, **Radio Illumination** is electrically part of **Instrument Illumination**. Since it has no electrical connection at all with the actual **Radio** circuit, it is not shown on the **Radio** page.

Troubleshooting Hints point the technician in a general direction, but are not intended as a step-by-step procedure. Ignition troubleshooting is an exception to this. It includes a step-by-step procedure of basic quick checks to locate some of the more common **Ignition System** problems. Read the Shop Manual for more detailed repair procedures.

The **Grounds** pages show detailed views of multiple component ground points. This is useful for checking interconnections among the ground circuits of different diagrams.

Notes, Cautions, and Warnings appear in boxes on text pages and contain important car and mechanic safety information.

Notes give added information to help complete a particular procedure. Cautions are included to prevent making an error that could damage the vehicle. Warnings highlight areas where carelessness can cause personal injury. The following list contains some general **Warnings** that should be followed when working on a vehicle.

- Always wear safety glasses for eye protection.
- Use safety stands whenever a procedure requires being under a vehicle.
- Be sure that the **Ignition Switch** is always in the OFF position, unless otherwise required by the procedure.
- Set the parking brake when working on any vehicle. An automatic transmission should be in PARK. A manual transmission should be in NEUTRAL.
- Operate the engine only in a well-ventilated area to avoid the danger of carbon monoxide.
- Keep away from moving parts when the engine is running, especially the fan and belts.
- To prevent serious burns, avoid contact with hot metal parts such as the radiator, exhaust manifold, tail pipe, catalytic converter, and muffler.
- Do not allow flame or sparks near the battery. Gases are always present in and around the battery cell. An explosion could occur.
- Do not smoke.
- To avoid injury, always remove rings, watches, loose hanging jewelry, and loose clothing.

2 HOW TO FIND THE ELECTRICAL PROBLEM

TROUBLESHOOTING STEPS

These six steps present an orderly method of troubleshooting:

Step 1. Verify the problem.

- Operate the complete system and see all symptoms for yourself in order to:
 - check the accuracy and completeness of the customer's complaint.
 - learn more that might give a clue to the nature and location of the problem.

Step 2. Narrow the problem.

- Using the EVTMM, narrow down the possible causes and locations of the problem in order to more quickly find the exact cause.
- Read the description of *How the Circuit Works* and study the wiring diagram. You should then know enough about the circuit operation to figure out where to check for this trouble.

Step 3. Test the cause.

- Use electrical test procedures to find the specific cause of the symptoms.
- *Troubleshooting Hints* will give some helpful ideas.
- The *Component Location* charts and the pictures will help you find components, grounds, and connectors.

Step 4. Verify the cause.

- Confirm the fact that you have found the correct cause through operating the parts of the circuit you think are good.

Step 5. Make the repair.

- Repair or replace the faulty component.

Step 6. Verify the repair.

- Operate the system as in Step 1 and check that your repair has removed all symptoms, any new

details. You will find the circuits in this manual to be helpful with these special tests.

TROUBLESHOOTING TOOLS

JUMPER WIRE

This is a test lead used to connect two points of a circuit. A **Jumper Wire** can complete a circuit by bypassing an open.

Uses: Bypassing Switches or Open Circuits

WARNING

Never use a jumper wire across high resistance loads (motors, etc.) connected between hot and ground. This direct battery short may cause injury or fire.

VOLTMETER

A DC **Voltmeter** measures circuit voltage. Connect negative (- or black) lead to ground, and positive (+ or red) lead to voltage measuring point.

OHMMETER

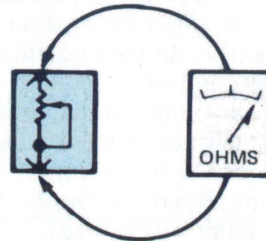

Figure 1— Resistance Check

An **Ohmmeter** shows the resistance between two connected points (Figure 1).

TEST LIGHT

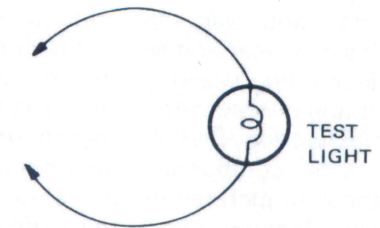

Figure 2—Test Light

A **Test Light** is a 12-volt bulb with two test leads (Figure 2).

Uses: Voltage Check. Short Check

SELF-POWERED TEST LIGHT

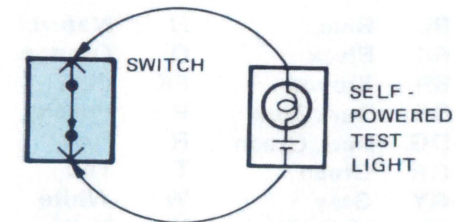

Figure 3—Continuity Check

The **Self-Powered Test Light** is a bulb, battery and set of test leads wired in series (Figure 3). When connected to two points of a continuous circuit, the bulb glows.

Uses: Continuity Check. Ground Check

CAUTION

When using a self-powered test light or ohmmeter, be sure power is off in circuit during testing. Hot circuits can cause equipment damage and false readings.

100% SATISFACTORY GUARANTEED

BUY IT NOW!

Click Here To Order

PayPal American Express Discover MasterCard VISA

TROUBLESHOOTING CHECKS

SWITCH CIRCUIT CHECK

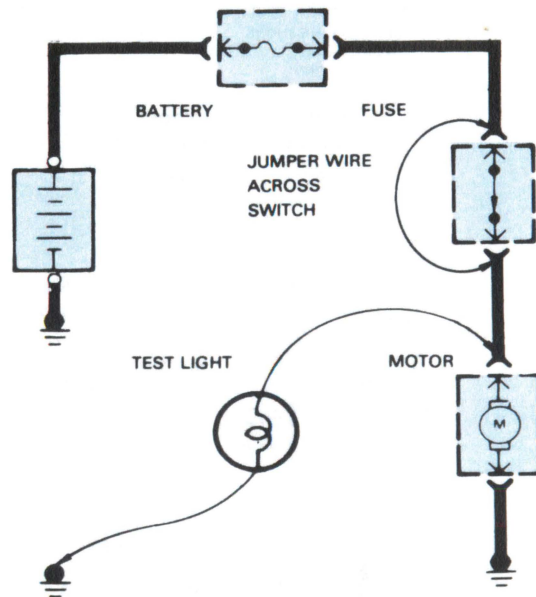

Figure 4—Switch Circuit Check and Voltage Check

In a bad circuit with a switch in series with the load, jumper the terminals of the switch to power the load. If jumping the terminals powers the circuit, the switch is bad (Figure 4).

CONTINUITY CHECK (Locating open circuits)

Connect one lead of **Self-Powered Test Light** or **Ohmmeter** to each end of circuit (Figure 3). Light will glow if circuit is closed. Switches and fuses can be checked in the same way.

VOLTAGE CHECK

Connect one lead of **Test Light** to a known ground or the negative (-) battery terminal. Connect the other lead to the circuit when the

SHORT CHECK (short to ground)

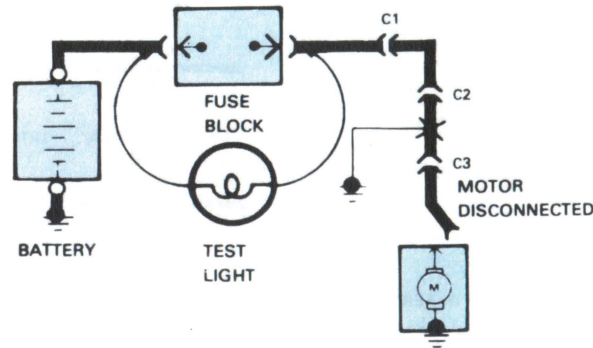

Figure 5— Short Check

A fuse that repeatedly blows is usually caused by a short to ground. It's important to be able to locate such a short quickly (Figure 5).

- 1) Turn off everything powered through the fuse.
- 2) Disconnect other loads powered through the fuse:
 - Motors: disconnect motor connector.
 - Lights: remove bulbs.
- 3) Turn **Ignition Switch** to RUN (if necessary) to power fuse.
- 4) Connect one **Test Light** lead to hot end of blown fuse. Connect other lead to ground. Bulb should glow showing power to fuse. *(This step is just a check to be sure you have power to the circuit.)*
- 5) Disconnect the **Test Light** lead from ground and reconnect it to the load side of the fuse.
 - If the **Test Light** is off, the short is in the disconnected equipment.
 - If the **Test Light** goes on, the short is in the wiring. You must find the short by disconnecting the circuit connectors one at a time until the **Test Light** goes out. For example: with a ground at X, the bulb goes out when C1 or C2 is disconnected, but stays on after disconnecting C3. This

means the ground is between C2 and C3
"GOOD GROUND" CHECK

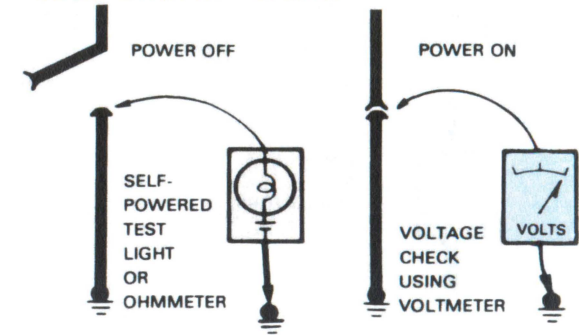

Figure 6 — Grounds Checks

Turn on power to circuit. Perform Voltage Check between suspected bad ground and frame. Any voltage means ground is bad.

Turn off power to circuit. Connect one lead of **Self-Powered Test Light** or **Ohmmeter** to wire in question, and the other to known ground. If bulb glows, circuit ground is OK (Figure 6).

TROUBLESHOOTING HINTS

The circuit schematics in this manual are designed to make it easy to identify common points in circuits. This knowledge can help narrow the problem to a specific area. For example, if several circuits fail at the same time, check for a common power or ground connection. (See *Power Distribution* or *Grounds*). If part of a circuit fails, check the connections between the part that works and the part that doesn't work.

For example, if low beam headlights work, but high beams and the indicator light don't work, then power and ground paths must be good. Since the dimmer switch is the component which switches this power to the high beam lights and indicator, it is most likely the cause of failure.

100% SATISFACTION GUARANTEED

BUY IT NOW!

Click Here To Order

PayPal American Express Discover MasterCard VISA

4 ELECTRICAL SYMBOLS

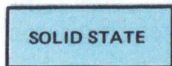
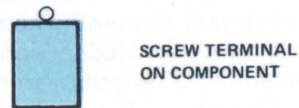
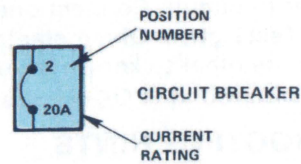
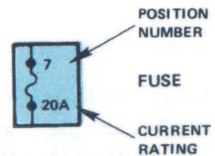
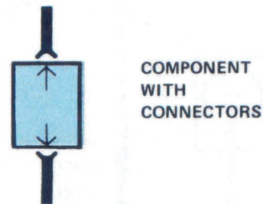
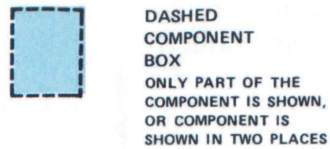

SEALED ELECTRONIC COMPONENT
ANY CIRCUITRY SHOWN INSIDE THE BOX IS A FUNCTIONAL EQUIVALENT. ONLY

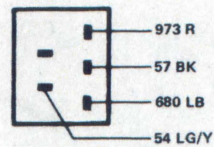

WIRE COLORS ARE LABELED FOR MATING HARNESS CONNECTOR

COMPONENT CONNECTOR END VIEW SHOWS PINS OR SOCKETS ON A COMPONENT TO AID IN BENCH TESTING

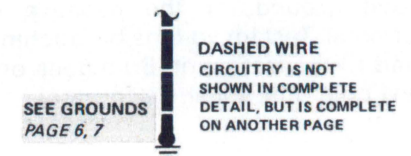
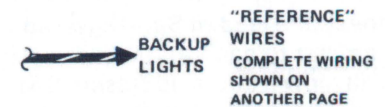
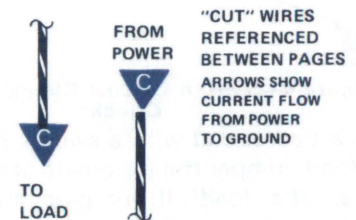
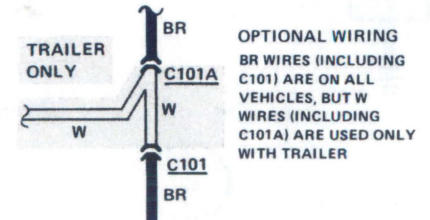
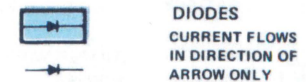
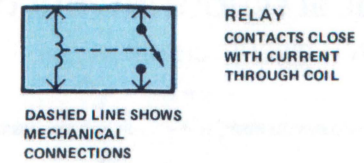
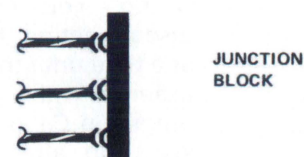
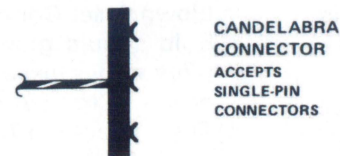
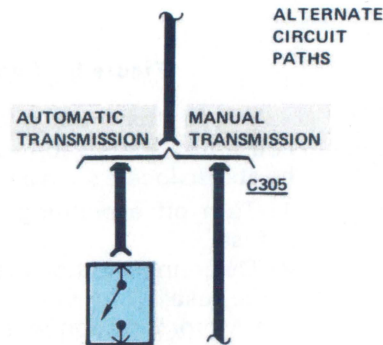
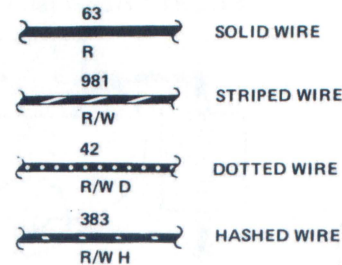
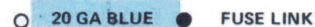
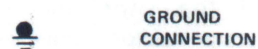
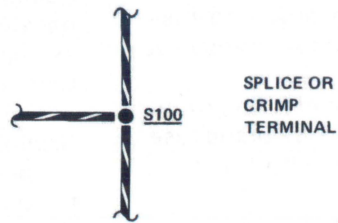
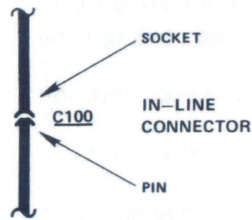

100% SATISFACTION GUARANTEED

BUY IT NOW!

Click Here To Order

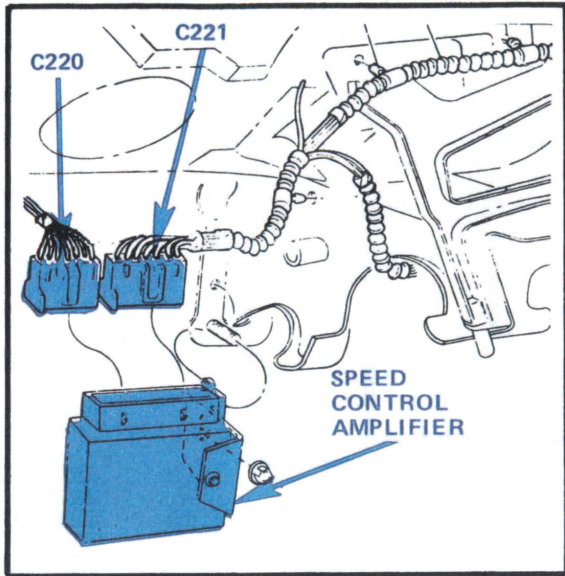

Figure 1 - LH Cowl Area

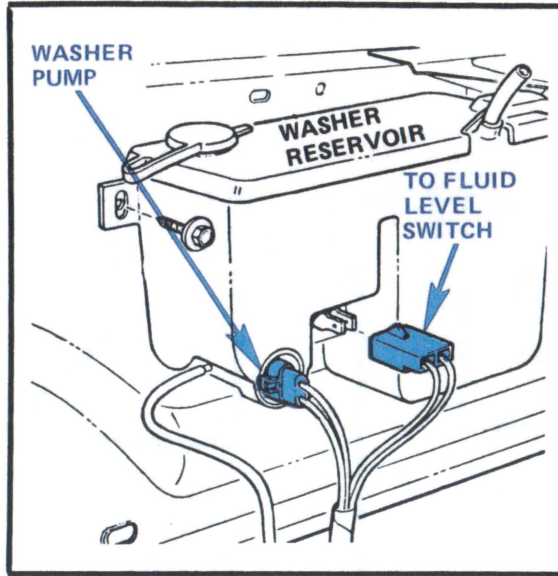

Figure 2 - LH Engine Cowl (5.0L Engine)

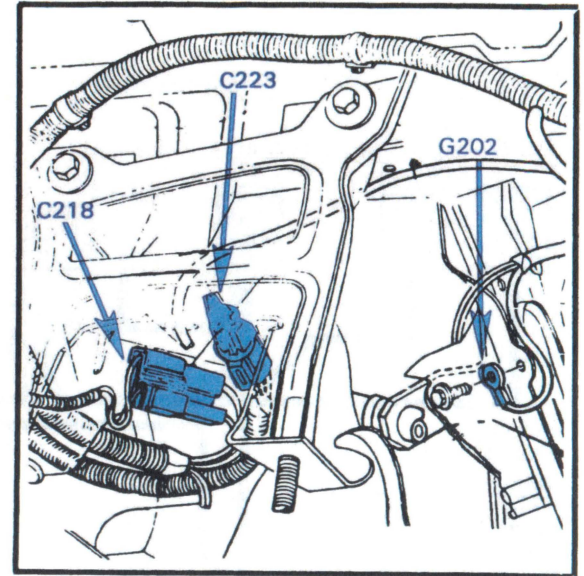

Figure 3 - Under LH Side of I/P

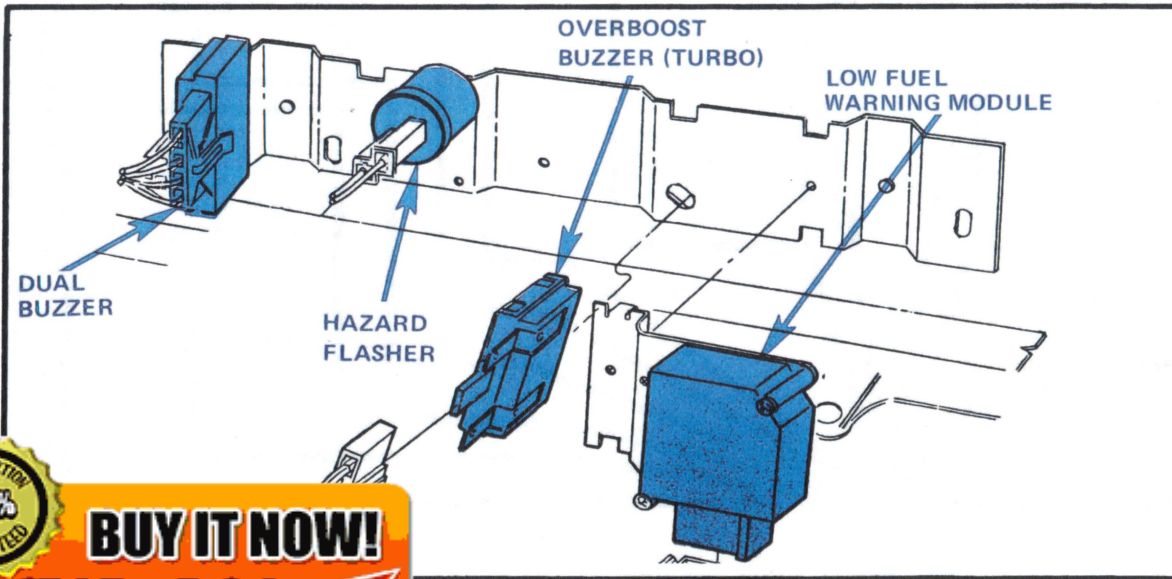

Figure 4 - Behind RH Side of I/P

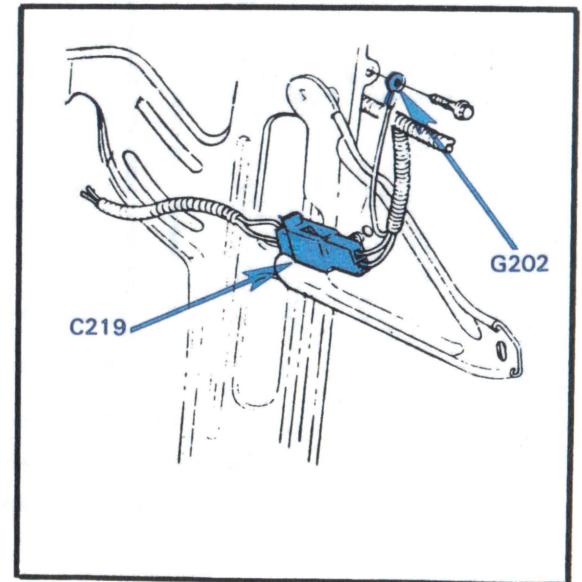

Figure 5 - Under LH Side Of I/P

SATISFACTION 100% GUARANTEED

BUY IT NOW!

Click Here To Order

6 GROUNDS (G201)

INSTRUMENT PANEL GROUND

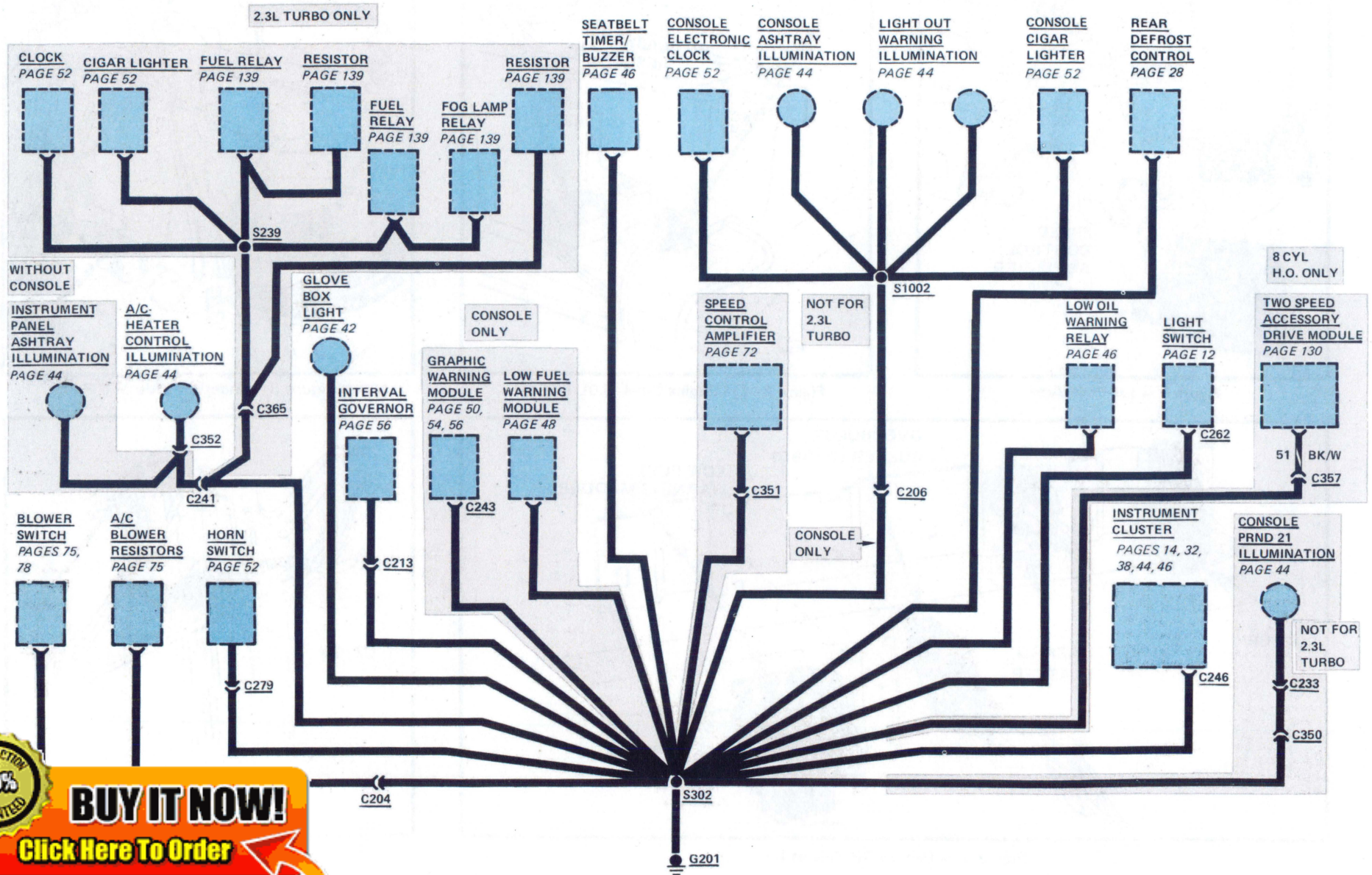

100% SATISFACTION GUARANTEED

BUY IT NOW!

Click Here To Order

The ground circuits shown here are complete, and connect several components together to screw terminal ground points. On other pages only parts of these circuits may be shown. Partial ground circuits are shown dashed on those pages.

All simple or component ground circuits are shown on the individual circuit pages, and are complete on those pages.

All wires are **57 BK** unless otherwise noted.

NOTE

See LH FRONT LIGHTS GROUND on pages 19 and 21.
See REAR LIGHTS GROUND on pages 26 and 27.

COMPONENT LOCATION

		Page-Figure	Color	Terminals
Connector C106	Near both RH and LH side markers	33-1	BR	2
Connector C152	LH fender apron		BL	1
Connector C168	Near starter relay		BR	2
Connector C204	Behind RH side of I/P above glove box	78-1	GY	4
Connector C206	Attached behind graphic warning module	51-1	GY	4
Connector C213	Under LH side of I/P	53-1	BK	6
Connector C233	Near transmission support brace	47-1	GY	2
Connector C241	Behind center of I/P above radio	78-1	BR	2
Connector C243	Attached to graphic warning module	51-1	GY	8
Connector C246	Behind LH side of I/P on instrument cluster	89-1	GY	14
Connector C262	Attached to light switch		BR	3
Connector C279	Beneath steering column		GY	3
Connector C312	LH side of transmission hump	47-1	GY	2
Connector C350	Behind center of I/P		BK	8
Connector C351	At LH shake brace		BR	6
Connector C352	Behind center of I/P		BR	2
Connector C359	Under LH side of I/P on shake brace		GY	4
Ground G102	Top RH side of radiator support	33-1		
Ground G103	Top LH side of radiator support	33-1		
Ground G201	Behind LH side of glove box	45-1		
Ground G301	LH side of trunk lid striker	35-2		
Splice S302	In 14401, near T/O to radio			
Splice S404	In 14290, near T/O to LH front side marker lamp			
Splice S408	In 14290, near T/O to RH front side marker lamp			
Splice S505	In 14405, near T/O to inertia switch			

RH FRONT LIGHTS GROUNDS (4 CYL 50 STATES AND CA, ADA)

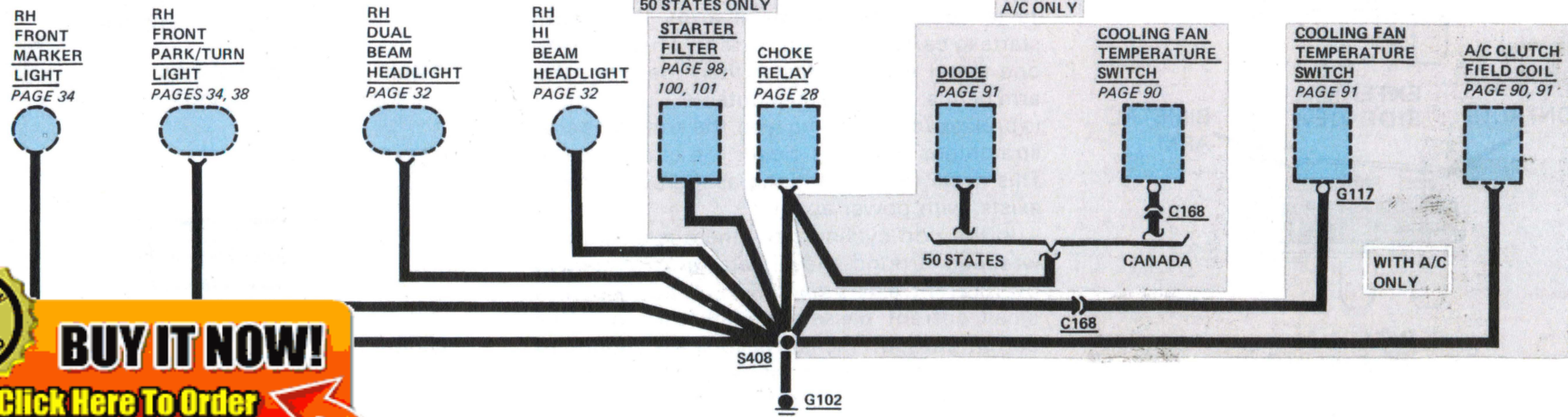

100% SATISFACTION GUARANTEED

BUY IT NOW!

Click Here To Order

8 FUSE BLOCK/CIRCUIT PROTECTION

REPLACEMENT OF FUSES/ CIRCUIT BREAKERS



GOOD FUSE

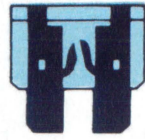

BLOWN FUSE

Fuses are mounted either in the **Fuse Block** or in-line. They are identified by the numbered value in amperes, and by a color code. Some positions may have either a fuse with adapter or a circuit breaker. Be sure to replace a fuse or circuit breaker with the same kind of unit and with the same ampere rating. Remove fuses in order to check them.

CIRCUIT BREAKER OPERATION

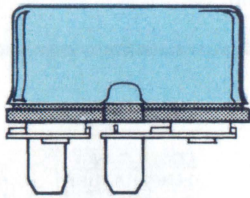

EXTERNAL
SIDE VIEW

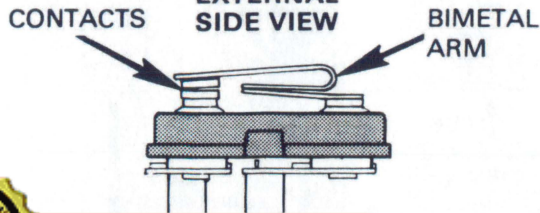

CONTACTS

BIMETAL
ARM

100% SATISFACTION GUARANTEED

BUY IT NOW!

Click Here To Order

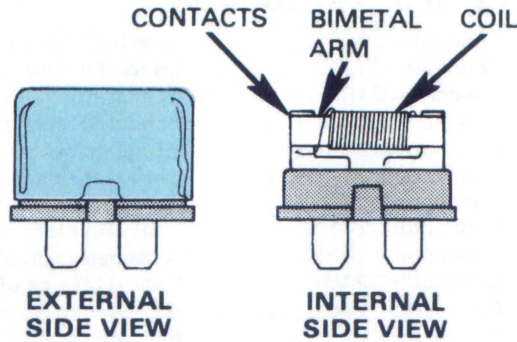

Non-Cycling Fuse Block Type

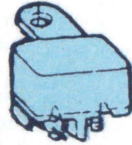

Cycling In-Line Type

Some circuits are protected by circuit breakers. (Abbreviated "c.b." in fuse chart.) They can be **Fuse Block** mounted or in-line. Like fuses, they are rated in amperes.

Each circuit breaker conducts current through an arm made of two types of metal fastened together (bimetal arm). If the arm starts to carry too much current, it heats up. As one metal expands faster than the other the arm bends, opening the contacts. Current flow is broken. In the cycling type, the arm cools and straightens out. This closes the circuit again. This cycle repeats as long as the overcurrent exists, with power applied.

In the non-cycling type, there is also a coil wrapped around the bimetal arm. When an overcurrent exists and the contacts open, a small current passes through the coil. This current through the coil is not large enough to operate a load, but it does heat up both the coil and bimetal arm. This keeps the arm in the open position until power is removed.

FUSE LINKS

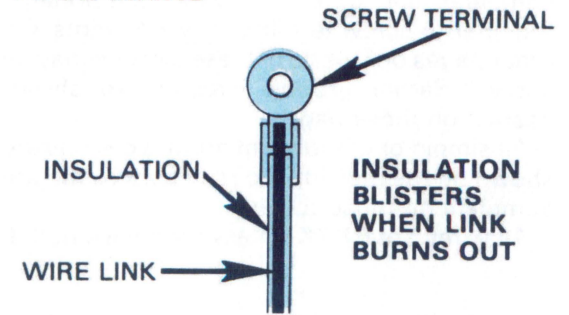

The fuse link is a short length of wire smaller in gage than the wire in the protected circuit. The wire is covered with a thick non-flammable insulation. An overload causes the link to heat and the insulation to blister. If the overload remains, the link will melt, causing an open circuit. The links are color coded for wire size as follows:

COLOR CODE

BLUE	20 GA
BROWN	18 GA
BLACK	16 GA
GREEN	14 GA

When replacing, make tight crimp joints or hot solder joints for good connections.

DIODES



Diodes are electrical devices that permit current to flow in one direction only. The current flows in the direction indicated by the arrow.

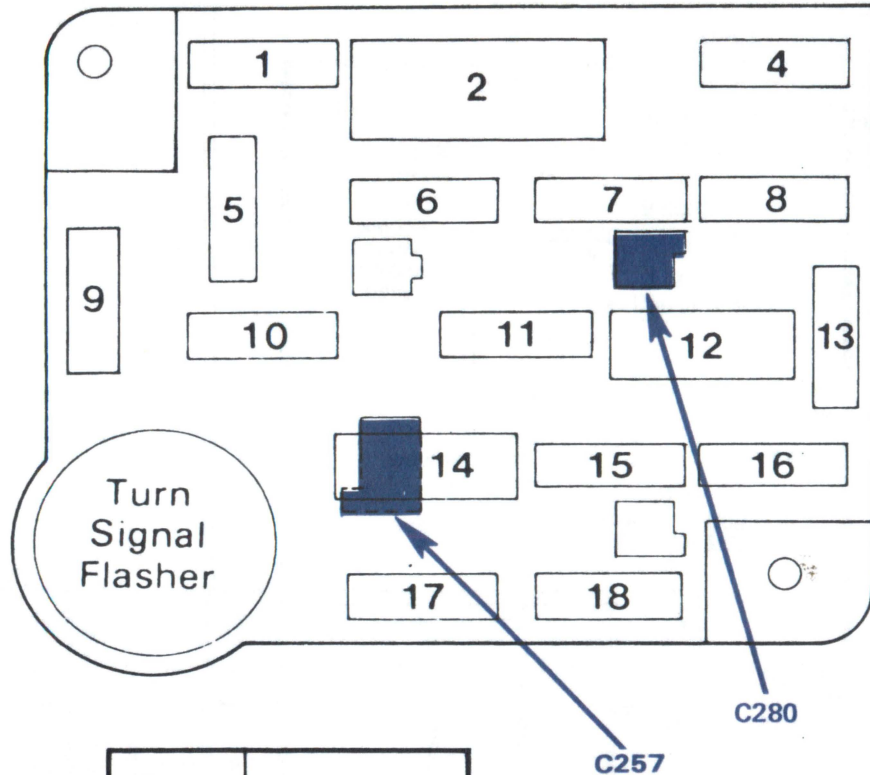

Fuse Position	Amps	Circuits Protected
1	15	Stop/Hazard Lights; Speed Control
2	6 c.b.	Windshield Wiper/Washer; Interval Wiper
4	10	Exterior Lights; Instrument Illumination
5	15	Turn Lights; Backup Lights
6	20	A/C Clutch; Speed Control; Rear Window Defrost; Trunk Release; Digital Clock; Light Out Warning.
7	—	(Not Used)
8	15	Courtesy Lights; Clock; Key Warning; Fuel Filler Door Release
9	15 or 30	Heater Blower (15 amps); A/C Blower (30 amps)
10	20	Passing Beam
11	15	Radio, Premium Sound
12	20 c.b.	Power Door Locks
13	5	Instrument Illumination
14	20 c.b.	Power Windows
15	—	(Not used)
16	20	Horn; Cigar Lighter; Digital Clock
17	—	(Not Used)
18	15	Seatbelt Buzzer; Warning Indicators; Carburetor Circuits; Tachometer; Low Fuel Warning; Idle Tracking Air Control; Restart Choke Control; Cooling Fan/Compressor Clutch Control.

Fuse Value Amps	Color Code
4	Pink
5	Tan
10	Red
15	Light Blue
20	Yellow

Power Distribution

The **Alternator** and **Battery** are connected together at the **Starter Relay** hot terminal. Other circuits originate at the **Starter Relay** hot terminal and are protected by fuse links. Low power circuits are also protected by fuses.

The **Ignition Switch** and **Light Switch** are powered at all times, as are **Fuses 1, 4, 8, 10** and **16**. The other fuses are powered through the **Ignition Switch** or the **Light Switch**

Position **3** is not used, and is covered by **Circuit Breaker 2**.

100% SATISFACTION GUARANTEED

BUY IT NOW!

Click Here To Order

10 CHARGE/POWER DISTRIBUTION

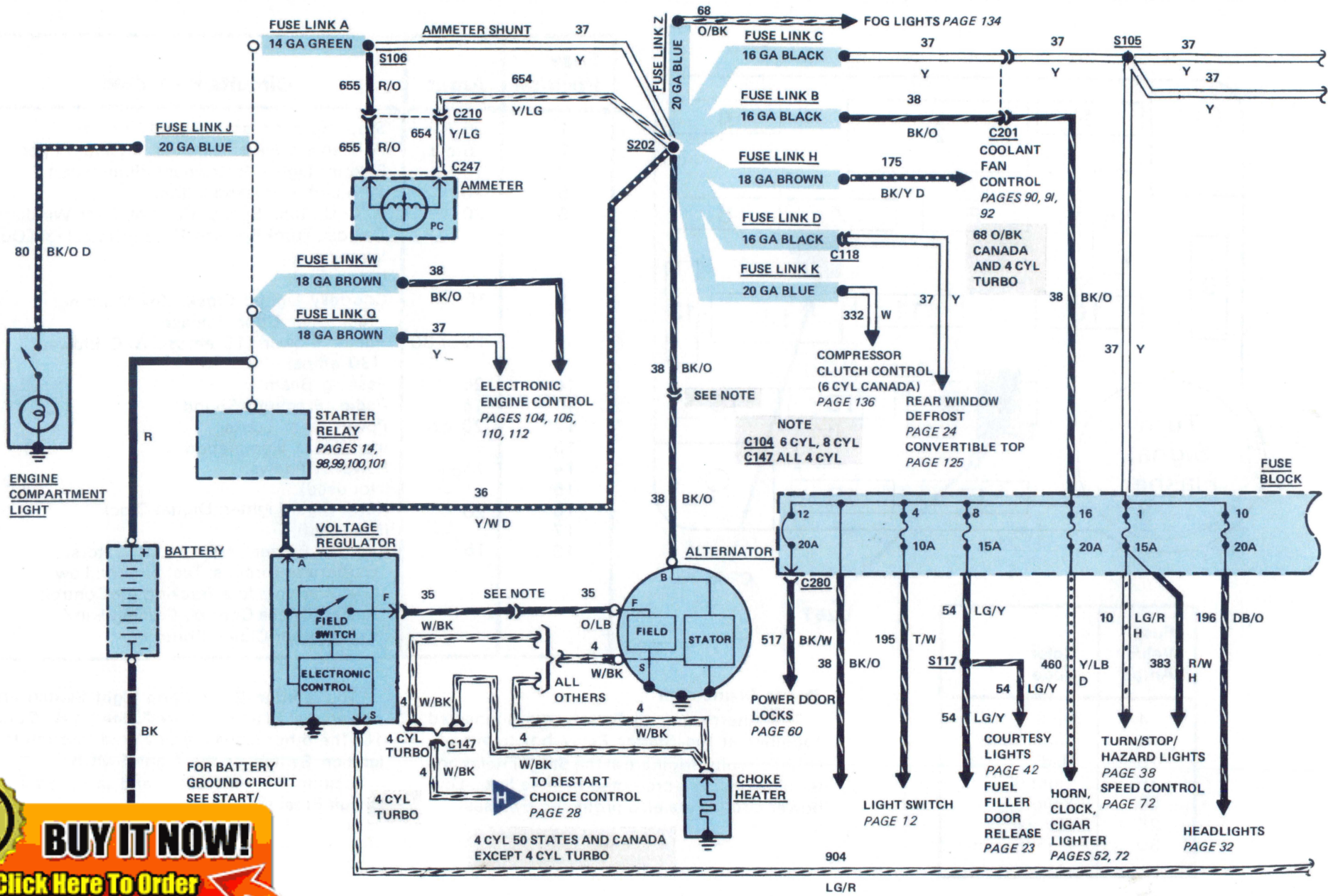

100% SATISFACTION GUARANTEED

BUY IT NOW!

Click Here To Order

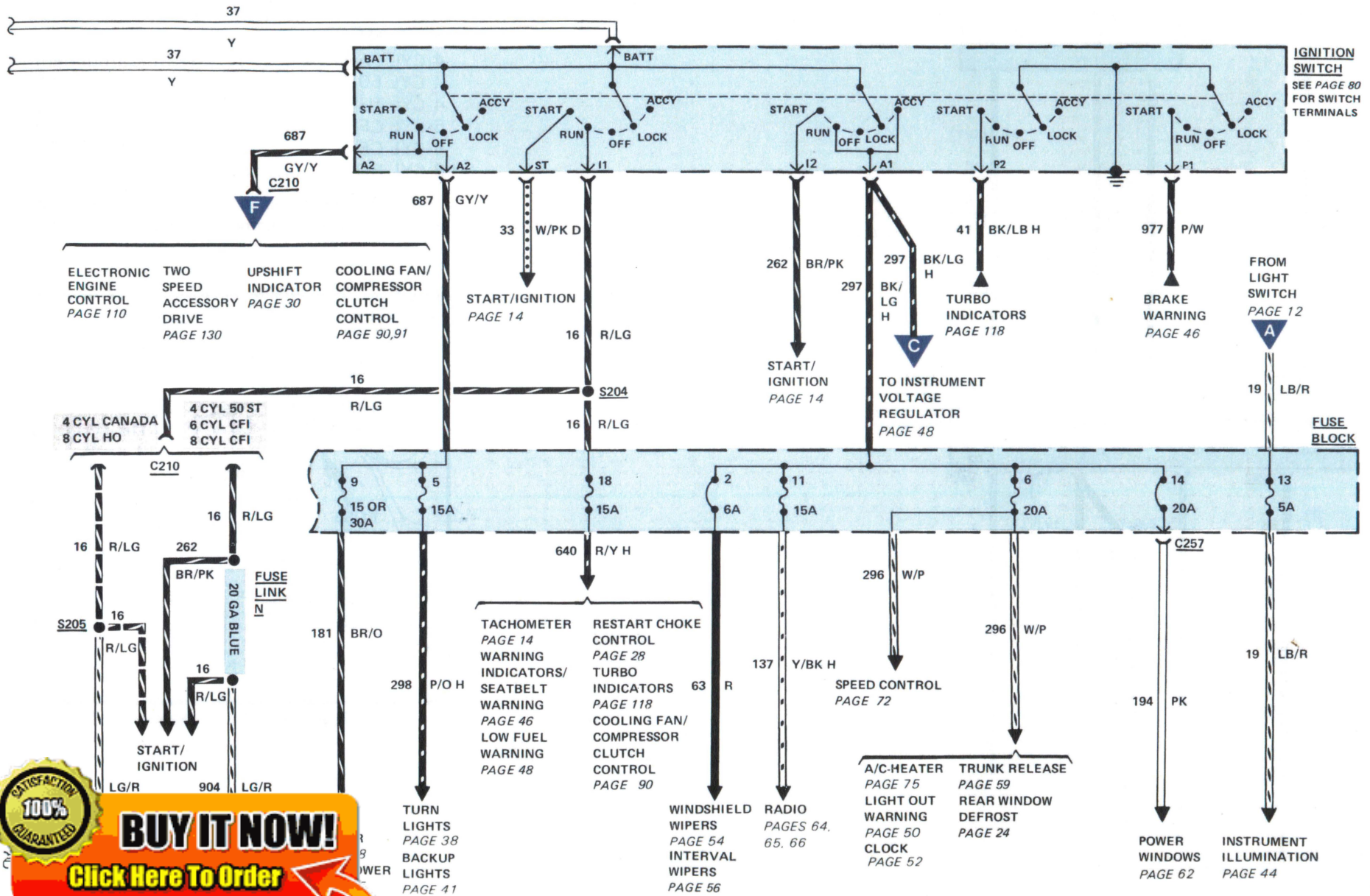

100% SATISFACTION GUARANTEED

BUY IT NOW!

Click Here To Order

12 CHARGE/POWER DISTRIBUTION (LIGHT SWITCH)

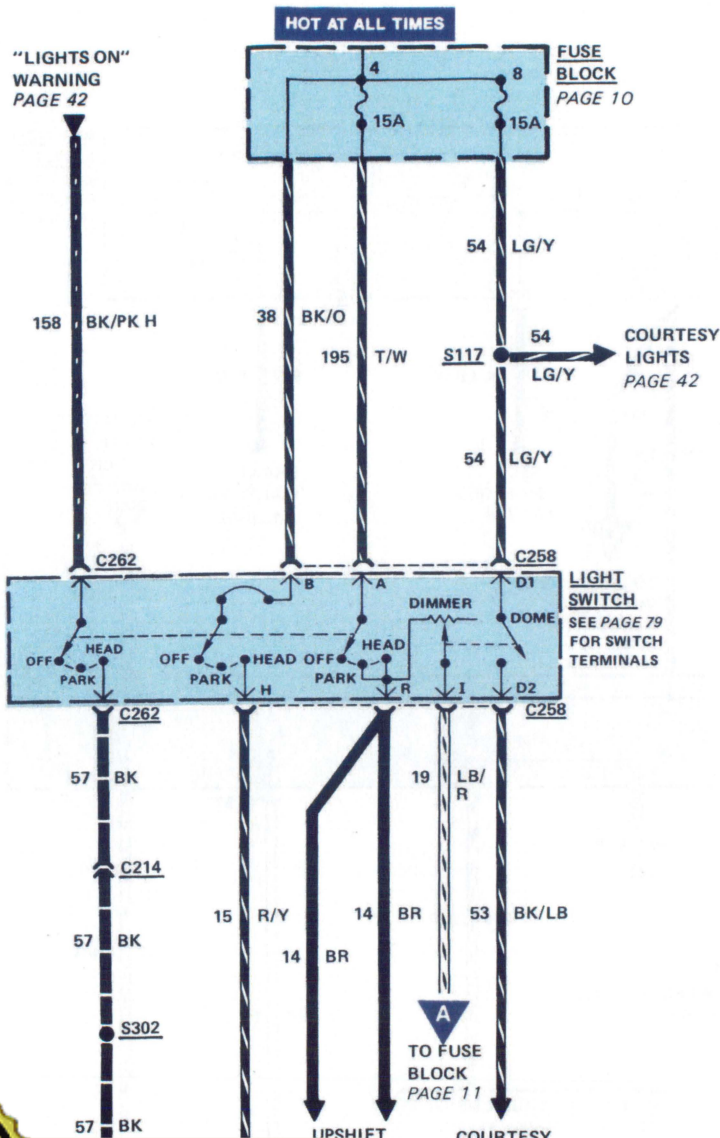

ENGINES

The following engines are used in the 1985 Mustang Capri:

- 4 CYL CANADA (2.3L Carbureted)
- 4 CYL 50 STATES (2.3L EEC-IV)
- 4 CYL TURBO (2.3L EFI)
- 6 CYL CFI (3.8L V6 EEC-IV)
- 8 CYL CFI (5.0L V8 EEC-IV)
- 8 CYL HO (5.0L V8 4V Carbureted)

Mid-year changes to 4 CYL TURBO circuits are shown in a supplement to this EVTM.

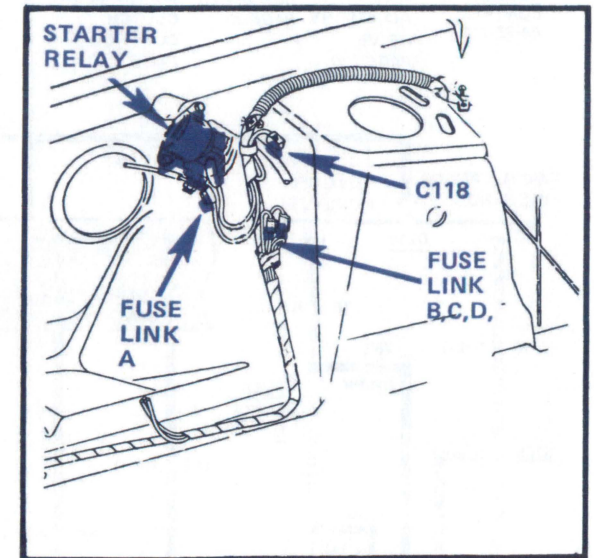

Figure 1 - RH Front Fender

SATISFACTION 100% GUARANTEED

BUY IT NOW!

Click Here To Order

PayPal, American Express, Discover, MasterCard, VISA

CHARGE

HOW THE CIRCUIT WORKS

The **Battery**, **Alternator**, and **Voltage Regulator** make up the **Charging System**.

With the **Ignition Switch** in **RUN**, **Battery** current flows through the solid-state **Electronic Control** of the **Voltage Regulator**. The **Electronic Control** operates the solid-state field switch which applies **Battery** voltage to the **Alternator** field through terminal **F**.

With current in the field and the rotor turning, the **Alternator** stator produces a DC voltage at terminal **B** (to **Battery**). This voltage balances the **Battery** voltage. If the voltages are different, the resulting current flow is indicated on the **Ammeter**. The **Choke Heater** operates only when the **Alternator** is generating current (through terminal **S**). Above 60°F, the heater causes a thermostatic spring to pull the choke plates open within 1 to 1.5 minutes. Below 60°F, the heater does not operate and normal choke action occurs.

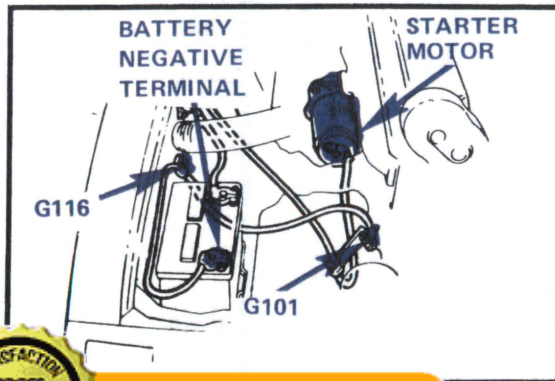

100% SATISFACTION GUARANTEED

BUY IT NOW!

Click Here To Order

PayPal, American Express, Discover, MasterCard, VISA

COMPONENT LOCATION

		Page-Figure	Color	Terminals
Alternator (4 cyl)	LH front of engine assembly			
(6 and 8 cyl)	RH front of engine assembly			
Ammeter	Part of instrument cluster			
Choke Heater	Attached to carburetor	25-1		
Fuse Links A, B, C, D, H, K, Q, W, Z	Near starter relay assembly	12-1		
Fuse Link J	At starter relay	61-1		
Fuse Links L, N	Near LH shock tower	25-2		
Starter Relay	RH fender apron in front of wheel well (except turbo)	12-1		
Voltage Regulator	RH fender apron attached below starter relay			
Connector C104	Near starter relay		BR	2
Connector C118	LH fender apron below starter relay	12-1	GY	1
Connector C147	Lower LH frame near shock tower		BK	3
Connector C201	Under LH side of I/P on shake brace.....	22-2	GY	8
Connector C210	Under LH side of I/P on shake brace.....	22-2	GY	12
Connector C214	Clipped to LH I/P support brace.....	45-3	GY	4
Connector C247	Behind LH side of I/P on instrument cluster	89-1	GY	14
Connector C258	Behind LH side of I/P attached to light switch	45-2	GY	7
Ground G101 (Non-Turbo)	Lower LH front of engine assembly	13-1		
Ground G101 (2.3L EFI Turbo)	Lower RH front of engine assembly	124-1		
Ground G201	Behind LH side of glove box	45-1		
Splice S105	In 14401, near T/O to windshield wiper switch			
Splice S106	In 14290, near T/O to starter motor relay			
Splice S117	In 14401 near fuse panel			
Splice S202	In 14290, near T/O to alternator regulator			
Splice S204	In 14401, near T/O to LH I/P speaker			
Splice S205	In 14290, near T/O to windshield wiper motor			
Splice S302	In 14401, near T/O to radio			

TROUBLESHOOTING HINTS

IMPROPER CHARGING

The most common charge system complaints are dead **Battery**, and **Ammeter** discharging at normal speed.

- Check **Fuse Link A** at **Starter Relay**.
- Check **Alternator** belt tension.
- Check **Battery** terminals and cable clamps.
- Check for clean and tight connections on **Alternator**, **Regulator**, and **Starter Relay**.

Read "Charging System Diagnosis" in Section 31-01 of Shop Manual for detailed **Charging System** tests.

NOTE

The Voltage Regulator with BLUE printing on the cover is used with Ammeter; RED printing with either Ammeter or Alternator Warning Indicator.

START

HOW THE CIRCUIT WORKS

The **Battery**, **Starter Motor**, **Starter Relay**, and **Ignition Switch** make up the **Starting System**. In vehicles with automatic transmission, the **Neutral Safety Switch** must be closed (PARK or NEUTRAL) in order to operate the **Starter Motor**.

Turning the **Ignition Switch** to START sends current through the **Starter Relay** coil and operates the relay. Current from the **Battery** then flows directly through the **Starter Relay** to the **Starter Motor** to start the engine.

When the **Ignition Switch** is in START, Battery voltage is applied to the START (white) wire of the **Ignition Module** through circuit 32. Full voltage is applied to the BATT terminal of the **Ignition Coil**. After the engine has started, **Ignition Coil** voltage is reduced through the **1.1 Ohm Resistance Wire**.

TROUBLESHOOTING HINTS

CHECK BATTERY AND CABLES

- Check condition of **Battery**. Recharge or replace if necessary. Read part 31-02 of Shop Manual.
- Check **Battery** posts and cable lugs.
- Check cable terminals at **Starter Relay**, engine ground, and **Starter Motor** and clean if necessary. Make sure cable wire strands are securely attached in terminals. Cables are tight when eyelet can't be easily turned by hand.

above).
Starter Motor.

COMPONENT LOCATION

		Page-Figure	Color	Terminals
Clutch Safety Switch.....	Above clutch pedal			
Distributor (8 cyl)	Top front of engine			
Fuse Link C	At starter relay assembly	12-1		
Ignition Coil (4 & 8 cyl)	LH fender apron	25-2		
(6 cyl)	Lower LH side of engine			
Ignition Module	LH fender apron	25-2		
Ignition Switch	Lower RH side of steering column	53-1		
Backup/Neutral Safety Switch...	Part of transmission assembly	22-4		
Starter Motor.....	Lower RH rear of engine	13-1		
Starter Relay	RH fender apron in front of wheel well	12-1		
Connector C107	Attached to LH side of transmission support	22-4	BR	4
Connector C111	LH fender apron	25-2	BK	4
Connector C112	LH fender apron	25-2	BK	3
Connector C113.....	Near distributor		BK	3
Connector C135 (8 cyl).....	Center of dash panel		GY	8
(4 cyl)	LH fender apron	25-2	GY	8
			BK	4
Connector C163.....	Rear face of RH shock tower		GY	8
Connector C201	Under LH side of I/P on shake brace.....	22-2	GY	12
Connector C210.....	Under LH side of I/P on shake brace.....	22-2	GY	12
Connector C246	Behind LH side of I/P on instrument cluster...	89-1	GY	14
Connector C350	Behind center of I/P		BK	8
Ground G101	Lower LH front of engine assembly	13-1		
Ground G116	Inside RH fender behind battery	13-1		
Ground G201	Behind LH side of glove box	45-1		
Splice S105	In 14401, near T/O to windshield wiper switch			
Splice S203	In 14401, near T/O to horn switch			
Splice S204	In 14401, near T/O to LH I/P speaker			
Splice S205	In 14290, near T/O to windshield wiper motor			
Splice S206	In 14290, near T/O to A/C cycling pressure switch			
Splice S302	In 14401, near T/O to radio			

IF STARTER RELAY CHATTERS OR DOESN'T CLICK (STARTER DOES NOT CRANK)

- Check **Battery** and cables (see above).
- Make sure **Starter Relay** bracket is grounded tightly.
- With R/LB wire removed from **Starter Relay**, and transmission in PARK or NEUTRAL, jumper this terminal on **Starter Relay** to main terminal (**Battery** connection). If **Starter Motor** works, check **Ignition Switch**. Check wiring to **Starter Relay** for open or dirty connections. If this jumper doesn't operate **Starter Relay**, replace it.

IF STARTER DOES NOT CRANK AND STARTER RELAY CLICKS

- Clean and tighten cable connection to **Starter Motor** terminal and relay terminals. Check cable to **Starter Motor** for damage and make sure wire strands are secure in eyelets.
- If still bad, repair or replace **Starter Motor**.

IF STARTER SPINS (HUMMING NOISE) BUT DOES NOT CRANK ENGINE

- Remove **Starter Motor**. Repair or replace starter drive.

100% SATISFACTION GUARANTEED

BUY IT NOW!

Click Here To Order

PayPal American Express Discover MasterCard VISA

- Read the Shop Manual for detailed Starting tests.

TACHOMETER TROUBLESHOOTING HINTS

TACHOMETER READS HIGH OR LOW

- Check that 3-position switch on front of tach (behind mask) is in proper position for number of cylinders in engine.

NO TACHOMETER INDICATION

- Check that the 3 nuts on the tach terminal studs behind the cluster, and the printed circuit connector to the cluster, are secure.
- With the **Ignition Switch** in the RUN position, check for battery voltage between the 2 o'clock terminal and the 6 o'clock terminal (as viewed from rear of cluster).
- Check for continuity from 6 o'clock terminal to G201.
- Disconnect the 2-terminal **Ignition Coil Connector**. Check for continuity between the DG/Y D wire and the 10 o'clock terminal.

IGNITION HOW THE CIRCUIT WORKS

The basic **Ignition System** contains the breakerless **Ignition Module**, the **Ignition Coil**, the **Distributor**, and the spark plugs and wires.

When the engine is cranking or running:

- The magnetic pickup in the **Distributor** sends pulses to the **Ignition Module** as each tooth of the rotor passes the pickup.
- The **Ignition Module** switches current on and off to the primary (TACH TEST) of the **Distributor**

... current makes
... produce a high-
... 10 volts;

- High voltage pulses are transmitted to the **Distributor**, which sends them to fire the spark plugs.

CAUTION
In the Dura Spark II system, a high-voltage pulse is produced when the Ignition Switch is turned OFF.

TROUBLESHOOTING HINTS

The following steps are intended only as quick checks to identify and locate some of the more frequent problems. If these checks do not solve the problem, refer to the **Ignition System** diagnosis procedure in the proper Ford Shop Manual for complete system tests.

If the **Ignition System** is OK, check the fuel system and the engine itself.

PRELIMINARY CHECKS

- Check **Battery** for state of charge and for clean, tight battery terminal connections.
- Inspect all wires and connectors for breaks, cuts, abrasions or burned spots. Repair or replace as necessary. Make sure all wires are connected correctly.
- Unplug all connectors and inspect for corroded or burned contacts. Repair as necessary and plug connectors back together. Do NOT remove grease in connectors.
- Check for loose or damaged spark plug or coil wires. If boots or nipples are removed on 8mm ignition wires, reline inside of each with new silicone di-electric compound.

SPECIAL TEST JUMPER

Make up a test jumper as shown in Figure 1 below. It is important to use only this test jumper when making these checks. Solid wire jumpers will not work for the quick checks.

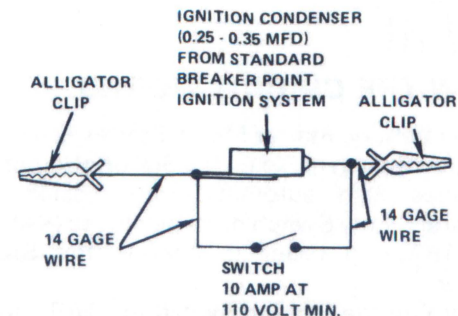

Figure 1 - Ignition Test Jumper

RUN MODE SPARK TEST

Step 1

- Remove **Distributor** cap and rotor from **Distributor**.
- Crank engine to align one tooth of armature (Figure 2) with magnet in pick-up coil (ignition OFF). Use a bump switch, or briefly touch a jumper between the R and R/LB terminals of the **Starter Relay**.
- Remove coil (center) wire from **Distributor** cap. Install modified spark plug (side electrode removed) in coil wire terminal.
- Turn **Ignition Switch** to RUN.
- Hold side of spark plug against engine block using insulated pliers. Tap base of **Distributor** with screwdriver handle and watch for **SPARK** at the spark plug.

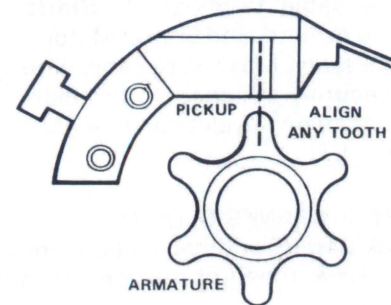

Figure 2 - Align Armature to Pickup

100% SATISFACTORY GUARANTEED

BUY IT NOW!

Click Here To Order

- If there is a good *SPARK*, primary circuit is OK. Skip to "START MODE SPARK TEST" below.
- If *NO GOOD SPARK*, perform **Step 2**.

Step 2

- Unplug **C111** (4 wire connector) at **Ignition Module**.
- In the harness side of the connector, connect the special test jumper (Figure 1) between the **DG/Y D** lead and the **BK/LG D** or **BK** leads. Use paper clips on connector socket holes to make contact.
- With the **Ignition Switch** in **RUN**, close the test jumper switch. Leave closed for about one second, then open. Repeat this several times. There should be a *SPARK* each time this switch is opened.
 - If there is *NO SPARK*, the problem is in the primary circuit — the **Ignition Switch**, **Ignition Coil**, **DG/Y D** lead, **BK/LG D** or **BK** lead, **R/LG** lead, or ground connection in the **Distributor**. Perform **Step 3**.
 - If there is *SPARK*, the primary circuit wiring and **Coil** are OK. The problem is in the **Distributor** pick-up, the **Ignition Module** bias power feed (**R** wire), or the **Ignition Module**. Perform **Step 6**.

Step 3

- Disconnect the test jumper lead from the **BK** or **BK/LG D** lead and connect to a good ground on the engine. Turn the test jumper switch **ON** and **OFF** several times as in **Step 2**.
 - If there is *NO SPARK*, the problem is in the **DG/Y D** lead, the **Coil**, or the coil feed circuit. Perform **Step 5**.
 - If there is *SPARK*, the problem is in the **R/LG** lead or ground connection in the **Distributor**. Perform

Step 4

- Connect an ohmmeter between the **BK** or **BK/LG D** lead and a good ground on the engine. With the meter on its lowest scale there should be no measurable resistance in the circuit.
 - If there is *RESISTANCE*, check ground connection in **Distributor** and **BK** or lead from module. Repair or replace as necessary. Remove meter plug in all connectors and repeat **Step 1**.
 - If there is *NO RESISTANCE*, the primary ground wiring is OK. Perform **Step 6**.

Step 5

- Disconnect the test jumper from the **DG/Y D** lead and ground and connect it between the **Tach-Test** terminal of the coil and a good ground on the engine.
- With the **Ignition Switch** in **RUN**, turn the jumper switch **ON**. Hold it **ON** for approximately one second and turn it **OFF** as in **Step 2**. Repeat this several times. There should be a *SPARK* each time the switch is turned **OFF**.
 - If there is *NO SPARK*, the problem is in the coil or in the primary circuit through the **Ignition Switch** to the coil **BATT** terminal.
 - Check coil for internal shorts or opens and for primary resistance (1.13 to 1.23 ohms) and secondary resistance (**R/LG** wire) (7.7 to 9.3 K ohms). Replace coil if necessary.
 - Check coil feed circuit for opens, shorts, or high resistance. Repair as necessary. Remove test jumper, plug in connectors, and repeat **Step 1**.
 - If there is *SPARK*, the coil and its feed circuit are OK. The problem is in the **DG/Y D** lead between the coil and the module. Check for open or short and

repair as necessary. Remove test jumper plug in all connectors, and repeat **Step 1**.

Step 6

- Connect a voltmeter between the **O/Y H** and **P/LB H** leads on the harness side of the module 4-wire connector.

CAUTION

If the vehicle has a catalytic converter, disconnect the air supply line between the Bypass Valve and the Manifold before cranking the engine with the Ignition Switch in OFF. This will prevent damage to the catalytic converter. After testing, run the engine for at least 3 minutes before reconnecting the air supply line to clear excess fuel from the exhaust system.

NOTE

Do not use a voltmeter which is combined with a dwell-meter. Slight needle oscillations (½ volt) may not be detectable on this type of test unit.

- Set meter on its lowest scale and crank the engine. Meter needle should oscillate slightly (approximately ½ volt).
 - If meter needle does *NOT OSCILLATE*, check circuit through magnetic pick-up (in **Distributor**) for open, shorts, shorts to ground, and resistance. Resistance between **O/Y H** and **P/LB H** leads should be 400—1000 ohms and between each lead and ground should be more than 70K ohms. Repair as necessary, plug in all connectors, and repeat **Step 1**.

100% SATISFACTION GUARANTEED

BUY IT NOW!

Click Here To Order

18 IGNITION

- If meter *OSCILLATES*, problem is in the power feed to the **Ignition Module**(R wire) or in the module itself. Perform **Step 7**.

Step 7

- Remove all meters and jumpers. Plug in all connectors.
- Turn the **Ignition Switch** to RUN and measure voltage to engine ground at:
 - **Battery** positive terminal. This reading should be at least 12 volts.
 - The **R** lead of the **Ignition Module**. Use a straight pin to pierce the insulation of the lead and connect voltmeter to pin (Figure 3).
- These two readings should be within 1 volt of each other.
 - If readings are *NOT WITHIN ONE VOLT*, check circuit feeding power to **R** lead for shorts, open, or high resistance. Repair as necessary and repeat **Step 1**.
 - If readings are *WITHIN ONE VOLT*, the problem is probably in the module. Disconnect the module and connect a known-good module in its place and repeat **Step 1**. If this corrects the problem reconnect the original module and recheck. If problem returns, remove the old module and install the new one.

START MODE SPARK TEST

Step 1

- Remove coil wire from **Distributor** cap. Install modified spark plug (side electrode removed) in coil wire terminal.

- Hold side of spark plug against engine block using insulated pliers. Have someone crank engine (**Ignition Switch** to START).
 - If there is a *GOOD SPARK*, the problem is in the **Distributor** cap, rotor, ignition cable(s), or spark plug(s).
 - If *NO GOOD SPARK*, perform **Step 2**.

Step 2

- Measure **Battery** voltage, and voltage at **W** wire of the module while cranking engine. Use a straight pin to pierce the wire (Figure 3).
- These two readings should be within 1 volt of each other.
 - If readings are *NOT WITHIN ONE VOLT*, check and repair the feed through the **Ignition Switch** to the **W** wire(**R/LB** lead). Recheck for spark (**Step 1**).
 - If readings *ARE WITHIN ONE VOLT*, or if there is still no spark after power feed to **W** wire is repaired, go on to **Step 3**.

Step 3

- Measure coil BATT terminal voltage while cranking engine.
- Reading should be within 1 volt of battery voltage.
 - If reading is *NOT WITHIN ONE VOLT*, check and repair the feed through the **Ignition Switch** to the coil (**BR/PK, R/LG** leads). Recheck for spark (**Step 1**).
 - If reading is *WITHIN ONE VOLT*, the problem is in the **Ignition Module**. Plug in a known-good module and recheck for spark (**Step 1**). If this corrects the problem, reconnect the original module and recheck. If problem returns, remove the old module and install the new one.

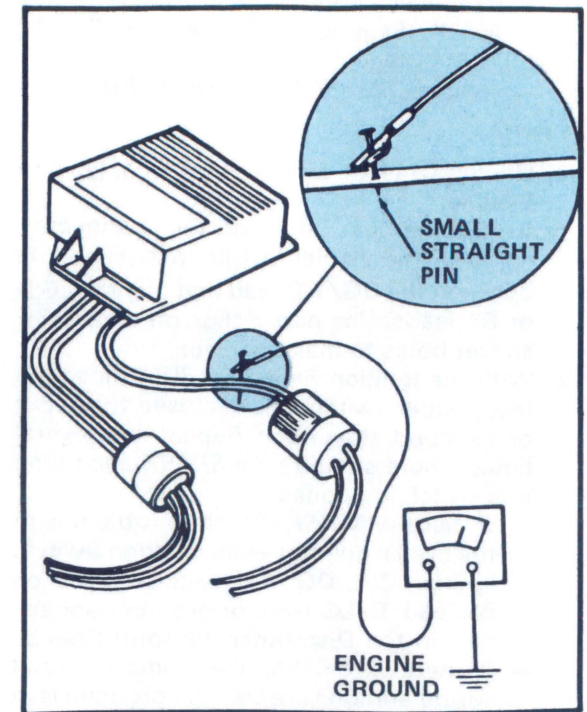

Figure 3 – Pin Test

NOTE

If the above steps do not solve the problem, see "Engine Diagnosis and Service" section of the Shop Manual.

100% SATISFACTION GUARANTEED

BUY IT NOW! in CAUTION

Click Here To Order

PayPal American Express Discover MasterCard VISA

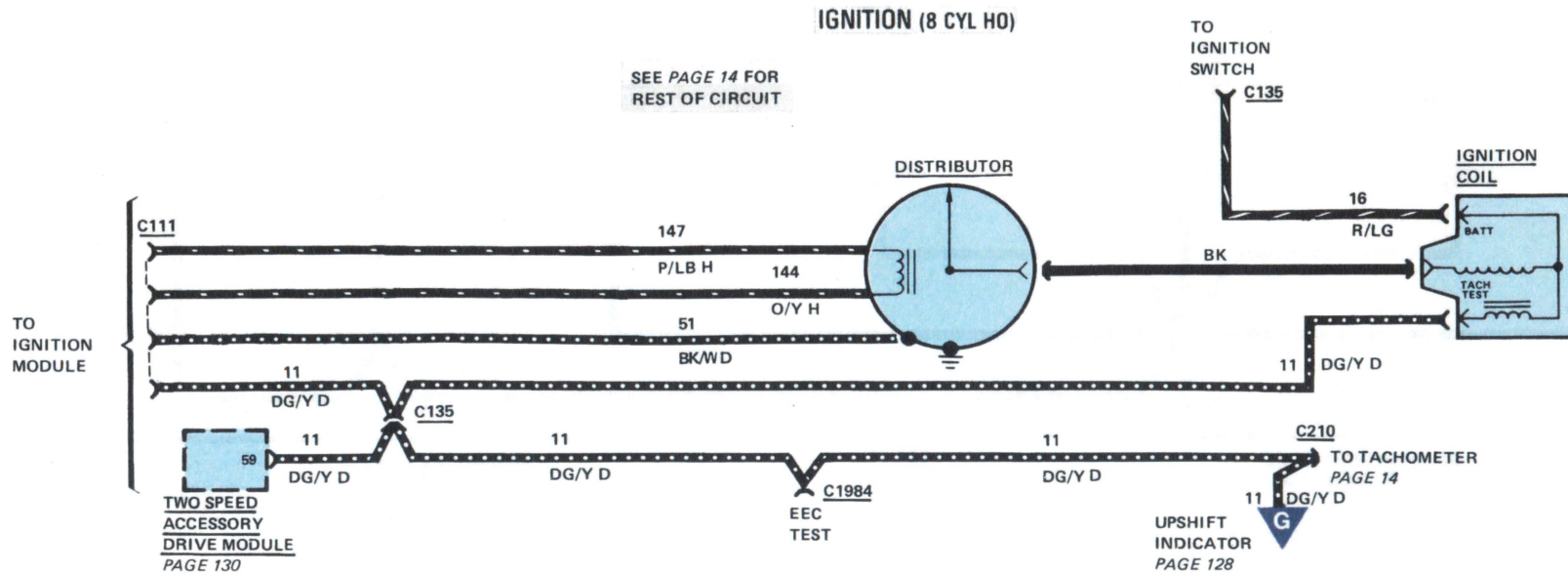

LH FRONT LIGHTS GROUND (8 CYL HO)

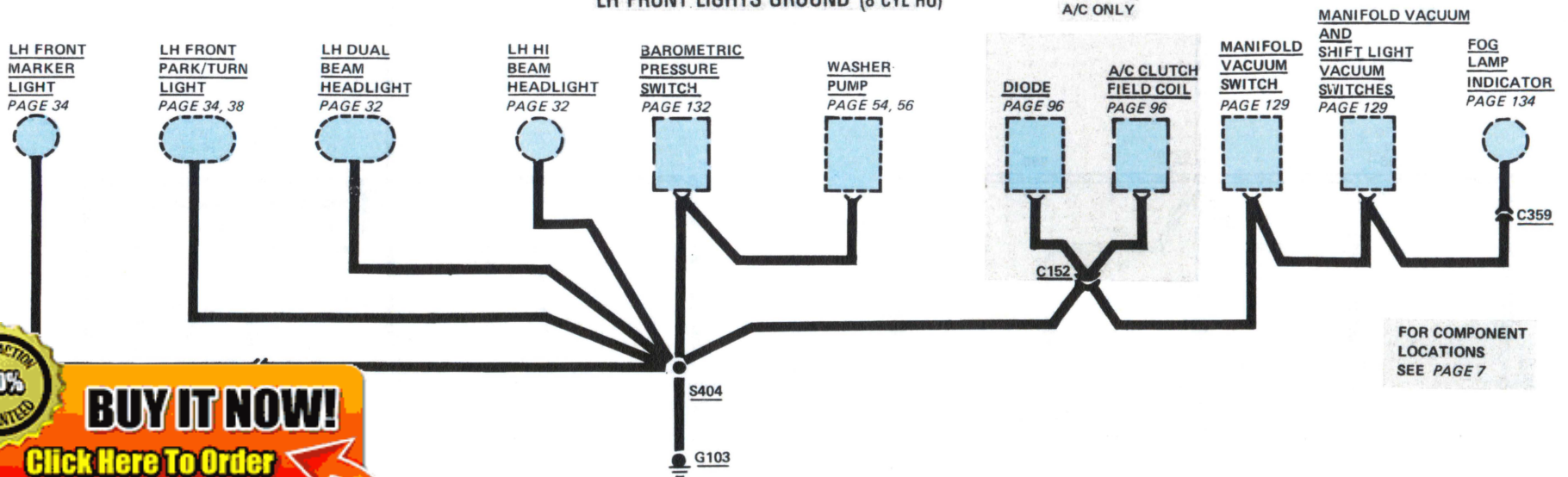

100% SATISFACTION GUARANTEED

BUY IT NOW!

Click Here To Order

PayPal, American Express, Discover, MasterCard, VISA

LH FRONT LIGHTS GROUND (4 CYL 50 STATES AND CANADA)

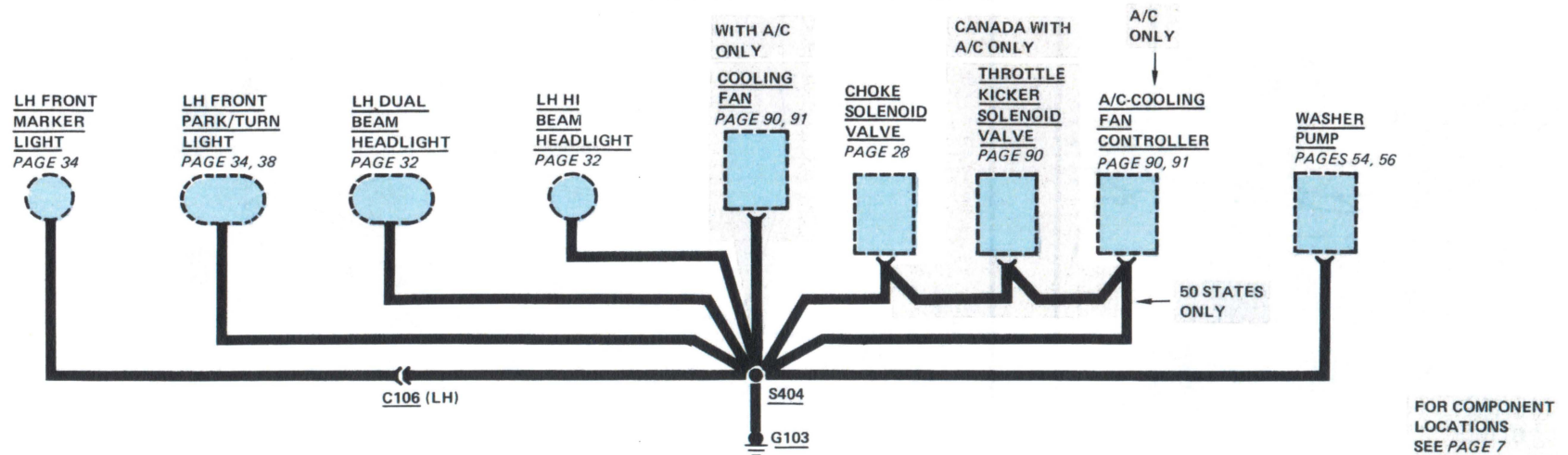

LH FRONT LIGHTS GROUND (6 CYL CFI AND 8 CYL CFI)

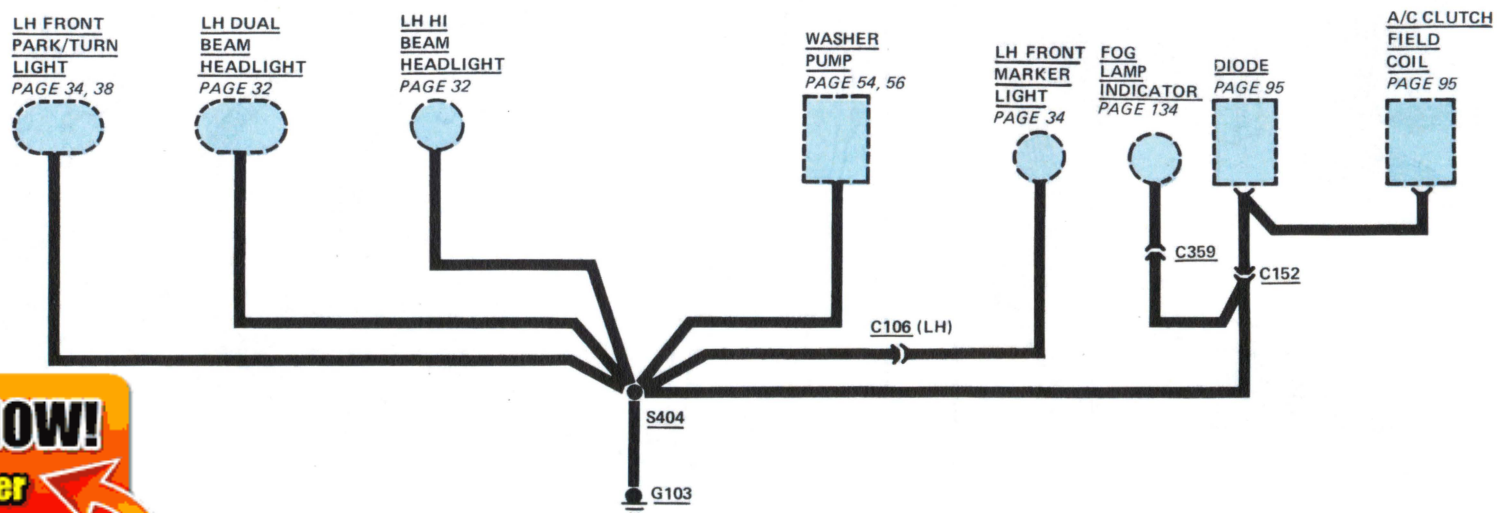

100% SATISFACTION GUARANTEED

BUY IT NOW!

Click Here To Order

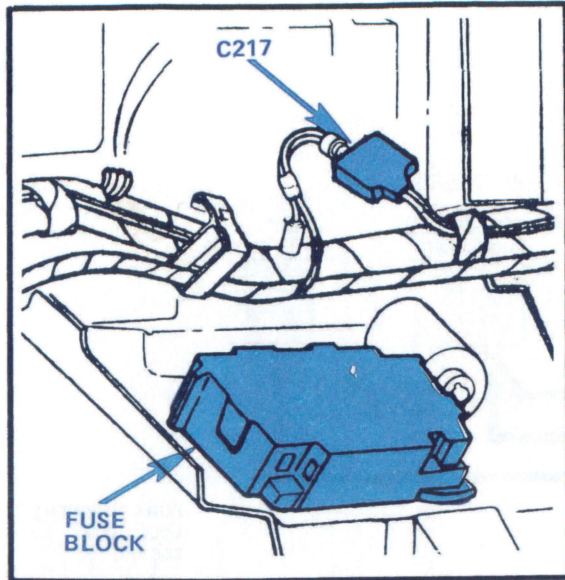

Figure 1 - Behind LH Side of I/P Above Fuse Block

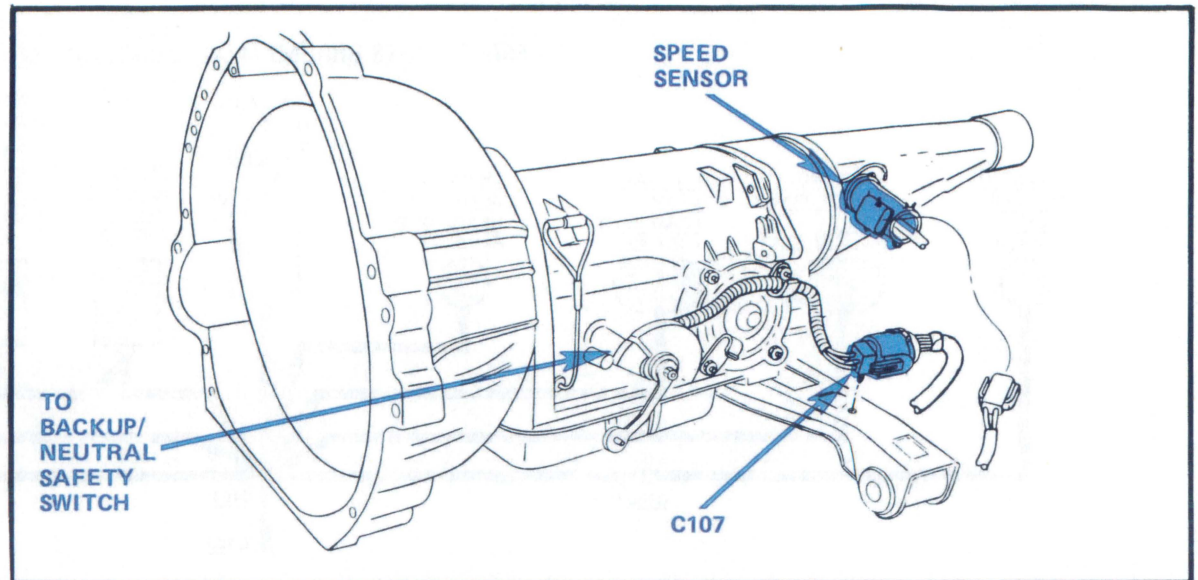
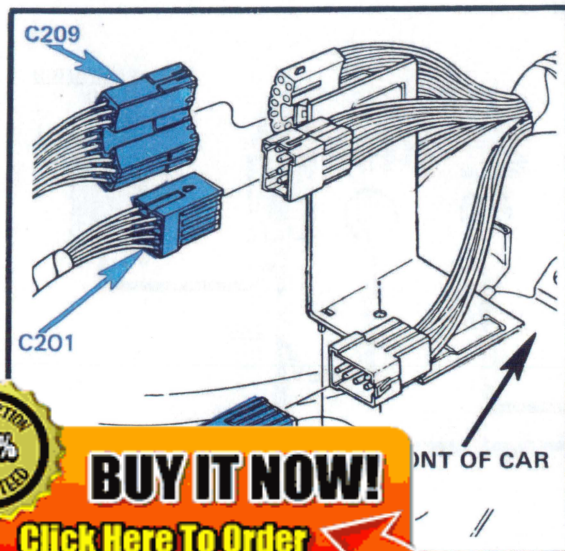

Figure 3 - Automatic Transmission Assembly (C-5)



100% SATISFACTION GUARANTEED

BUY IT NOW!

Click Here To Order

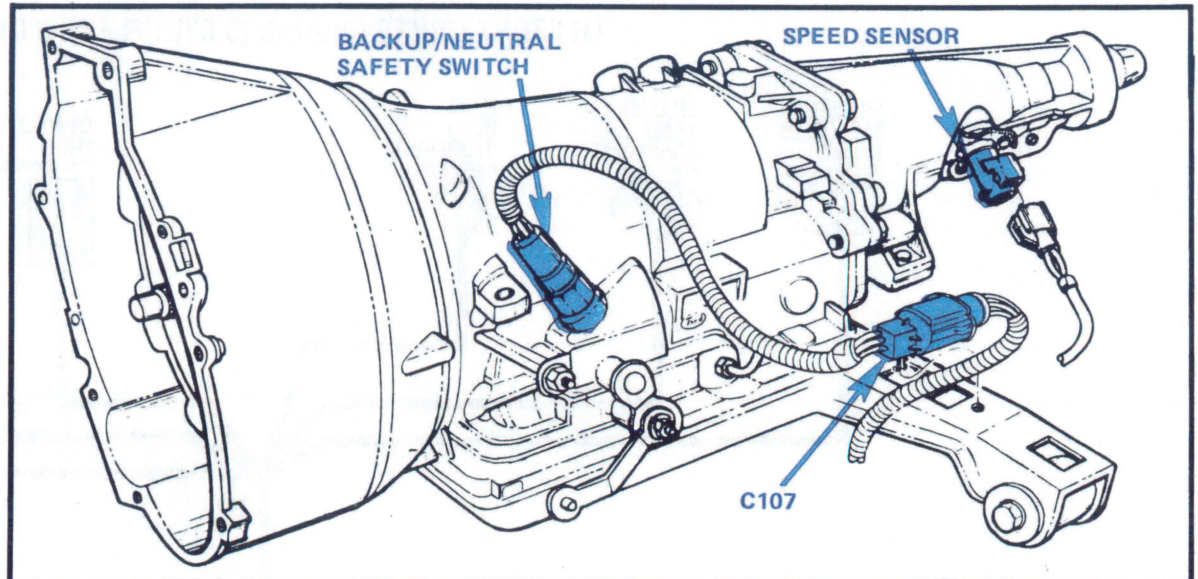
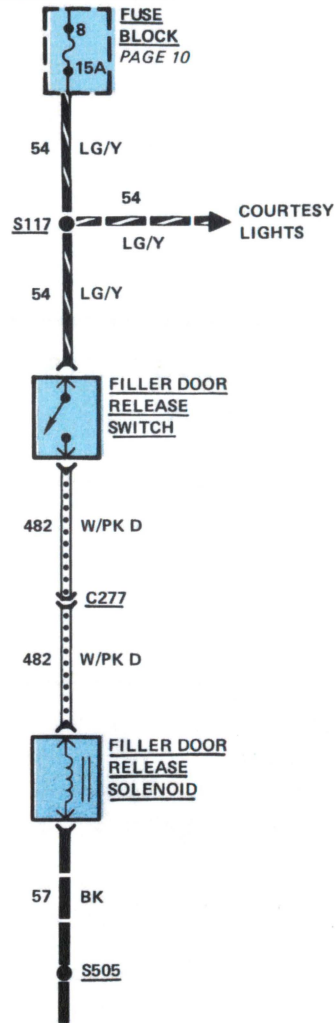

Figure 4 - Automatic Transmission Assembly (C-3)



HOT IN RUN OR START



COMPONENT LOCATION

		Page-Figure	Color	Terminals
Filler Door Release Solenoid	Near fuel tank line inlet			
Connector C277	LH cowl, near lower access hole		BR	2
Ground G301	LH side of trunk lid striker	35-2		
Splice S117	In 14401 near fuse panel			
Splice S505	In 14405, near T/O to inertia switch			

HOW THE CIRCUIT WORKS

With the **Ignition Switch** in Start or Run, power is made available through **Fuse 8**. When the **Filler Door Release Switch** is closed, power is applied to the **Filler Door Release Solenoid**. Note that this solenoid can be manually operated from inside the trunk.

TROUBLESHOOTING HINTS

RELEASE DOESN'T WORK

- Check **Fuse 8**. Make sure ground is clean and tight.
- Separate **C277**. Check for voltage at terminal with **Filler Door Release Switch** closed. Check switch and harness if bad.
- Check for continuity to ground through **Filler Door Release Solenoid**. Replace solenoid if bad.

100% SATISFACTION GUARANTEED

BUY IT NOW!

Click Here To Order

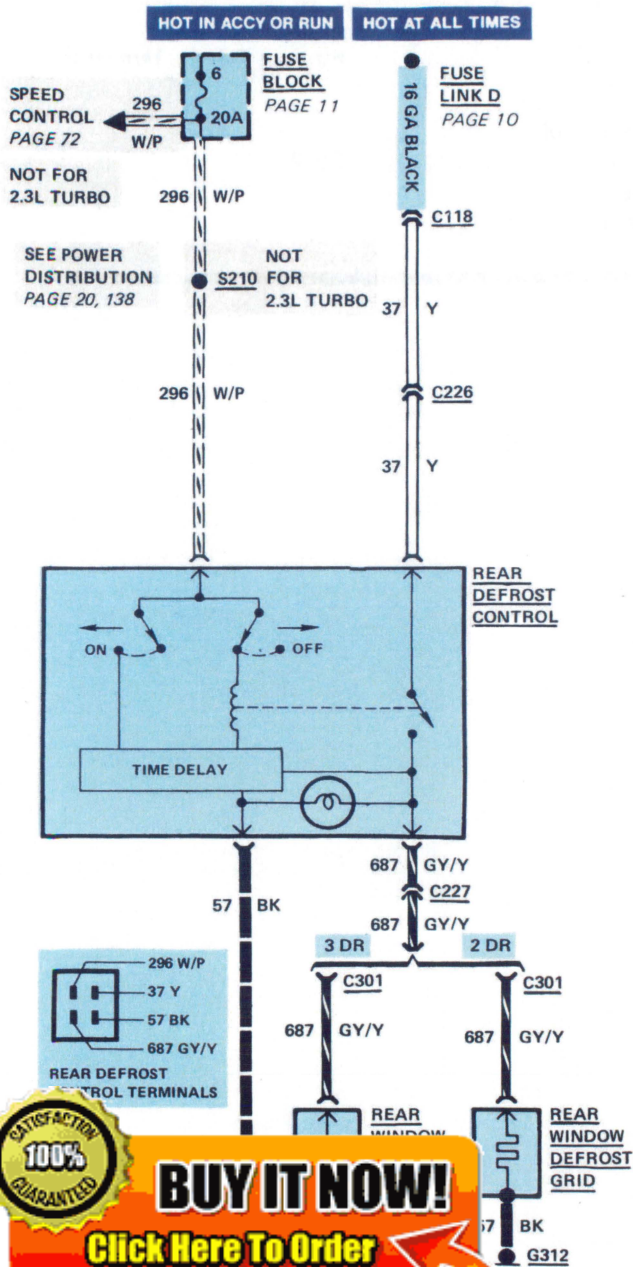

COMPONENT LOCATION

		Page-Figure	Color	Terminals
Rear Defrost Control	Center of I/P near radio			
Fuse Link D	At starter relay assembly	12-1		
Connector C118	RH fender apron below starter relay	12-1	GY	1
Connector C226	Under RH side of I/P	41-1	BL	1
Connector C227	LH cowl at lower access hole	86-6	BR	1
Connector C301	Behind LH quarter trim panel	37-1	BR	1
Ground G201	Behind LH side of glove box	45-1		
Ground G307 (3 DR)	RH side of lift gate below window	37-1		
Ground G312 (2 DR)	Attached to RH window shelf support			
Splice S210	In 14401, near T/O to radio			
Splice S302	In 14401, near T/O to radio			

HOW THE CIRCUIT WORKS

With the Ignition Switch in ACCY or RUN, the Rear Defrost Control is powered through Fuse 6.

Pressing the momentary defrost switch ON closes the contacts of the defrost relay and starts the ten minute (approximate) timing cycle. Current now flows to the Rear Window Defrost Grid. When the defrost switch is released from ON, current stops flowing through the ON contact. The solid-state circuitry keeps the defrost relay coil energized.

Pressing the defrost switch OFF drops out the defrost relay. This removes power from the defrost circuit.

If the OFF switch is not pressed, power will remain on until the time delay runs out. Then the coil will drop out and remove power from the defrost circuit.

TROUBLESHOOTING HINTS

NO DEFROST OPERATION

- Check Fuse 6.
- Check that relay operates when switch is turned ON and OFF.
- Check power on Y wire at relay.

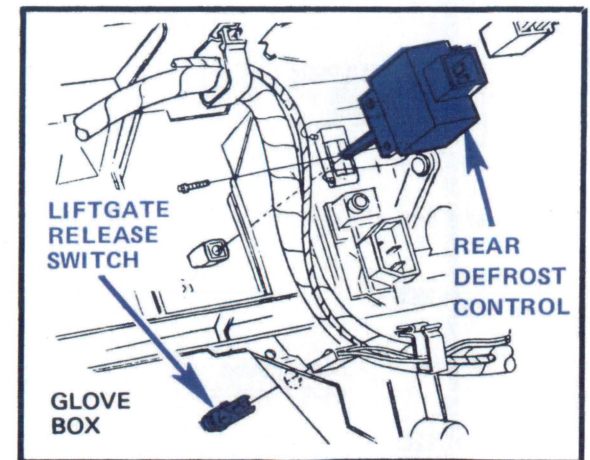

Figure 1 - Lower RH Corner of I/P

100% SATISFACTION GUARANTEED

BUY IT NOW!

Click Here To Order

PayPal American Express Discover MasterCard VISA

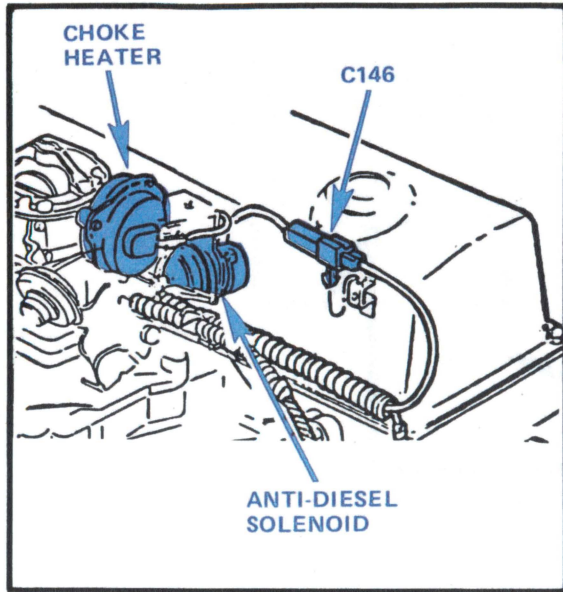

Figure 1 - Top Of 4 Cyl Engine
(Canada Only)

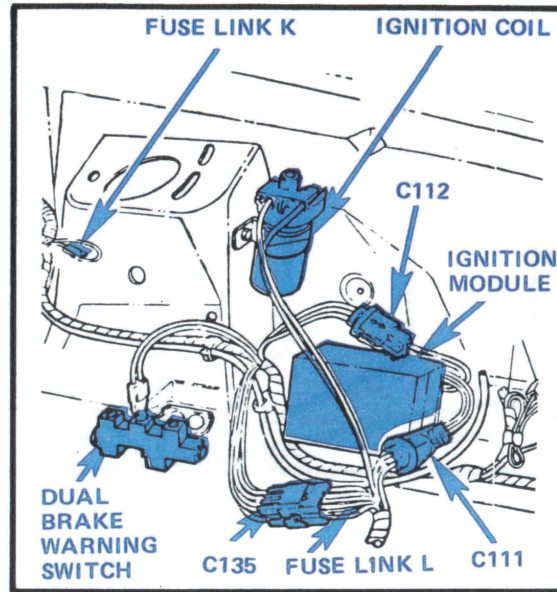

Figure 2 - Forward Of LH Shock Tower
(Canada Only)

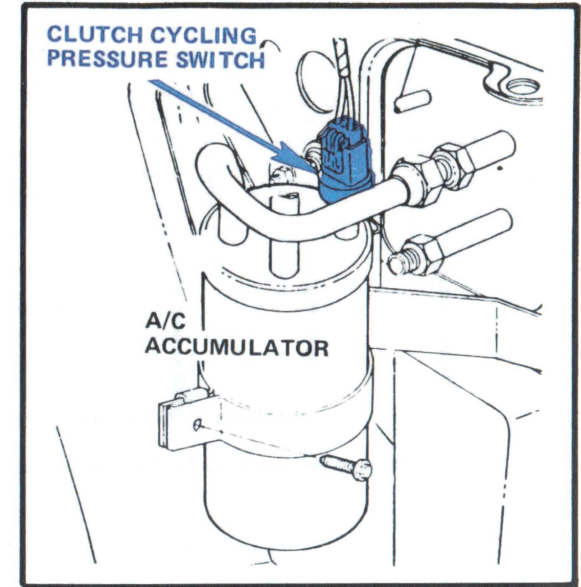
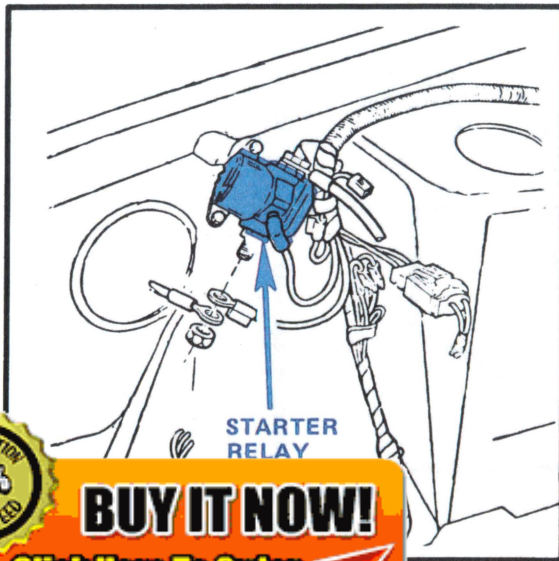

Figure 3 - Lower RH Side Of Dash Panel



STARTER RELAY



BUY IT NOW!

Click Here To Order

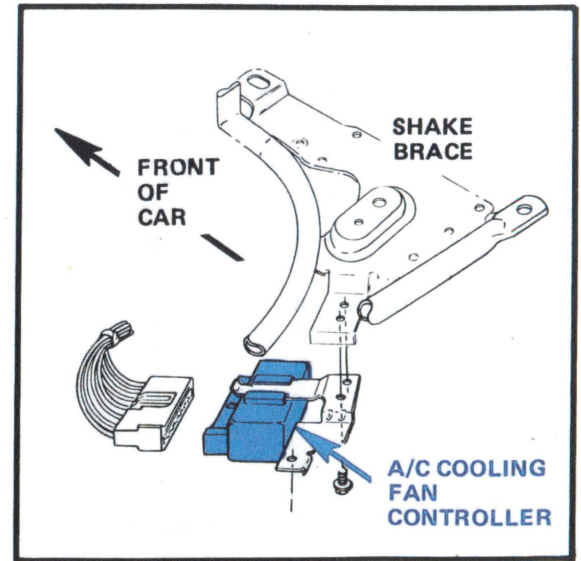
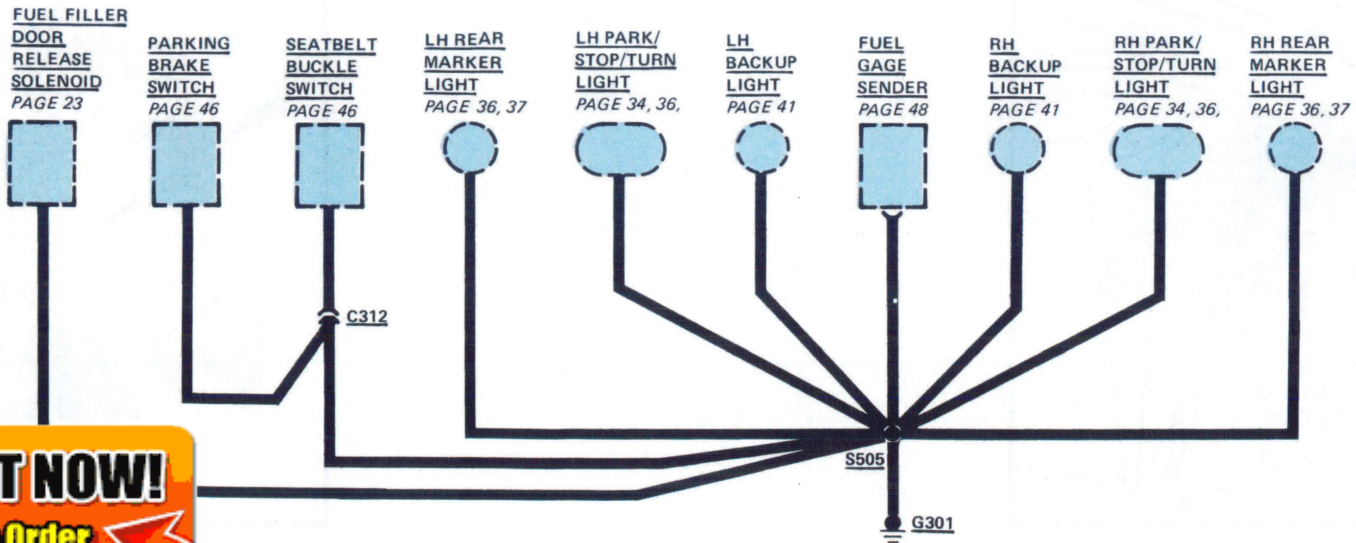
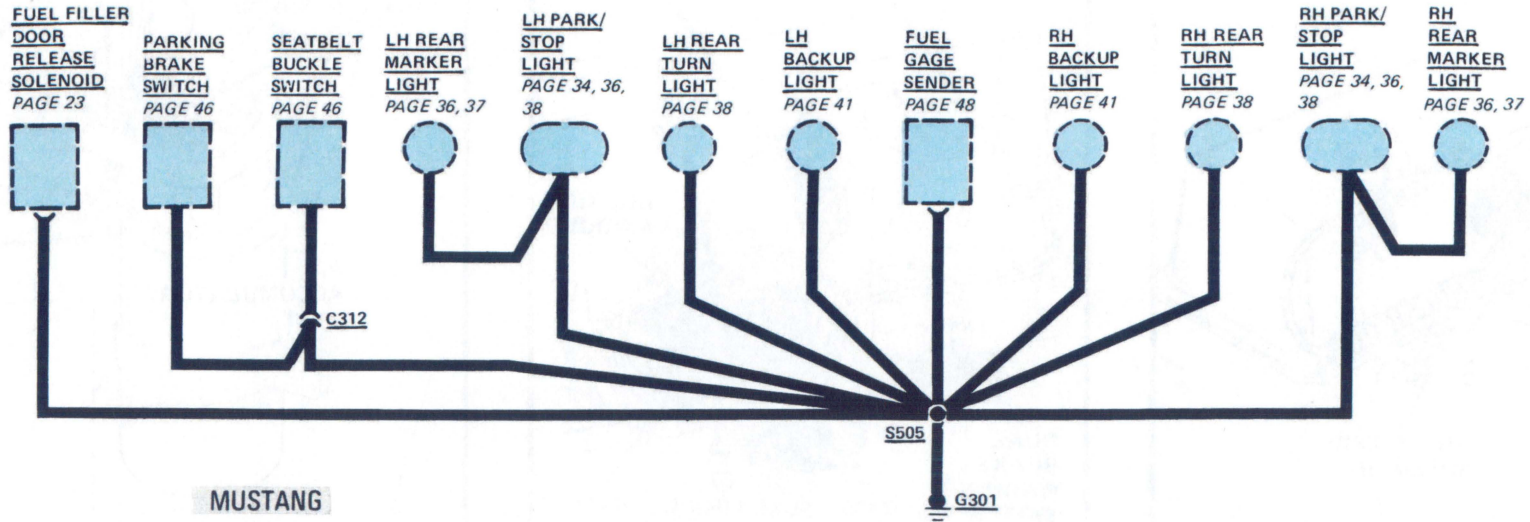

Figure 5 - Shake Brace Below Steering Column
(with A/C)



REAR LIGHTS GROUND (4 CYL 50 STATES AND CANADA, 8 CYL H0)



100% SATISFACTION GUARANTEED

BUY IT NOW!

Click Here To Order

PayPal | American Express | Discover | MasterCard | VISA

REAR LIGHTS GROUND (4 CYL TURBO, 6 CYL CFI, 8 CYL CFI)

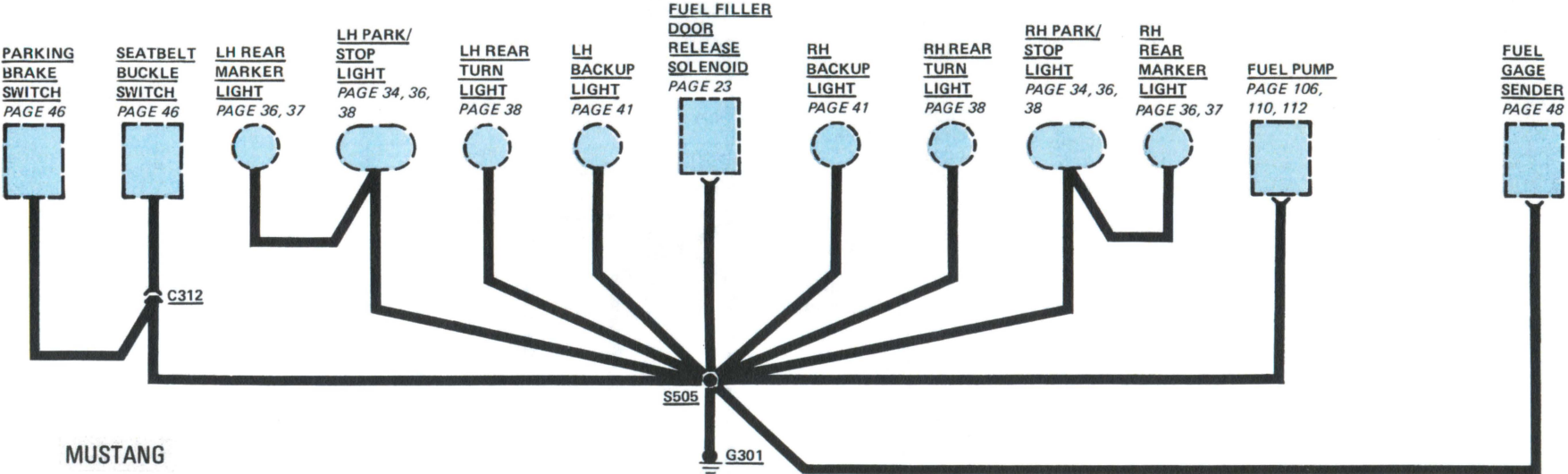

MUSTANG

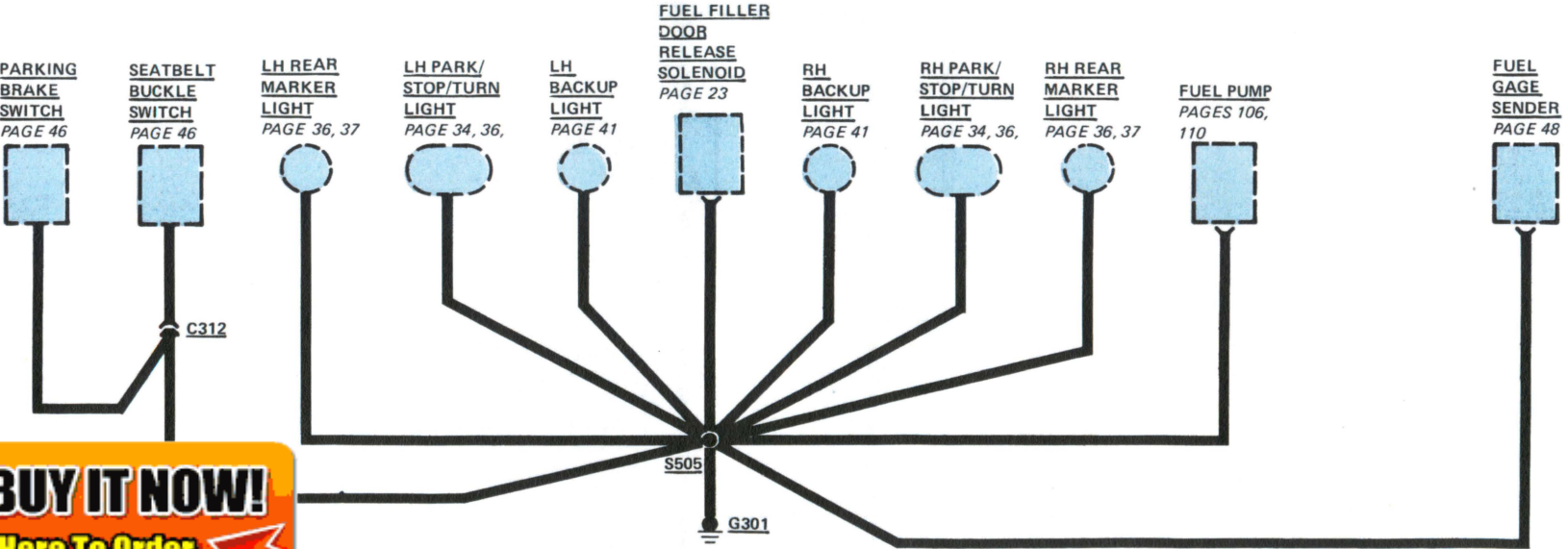

100% SATISFACTION GUARANTEED

BUY IT NOW!

Click Here To Order

28 RESTART CHOKE CONTROL

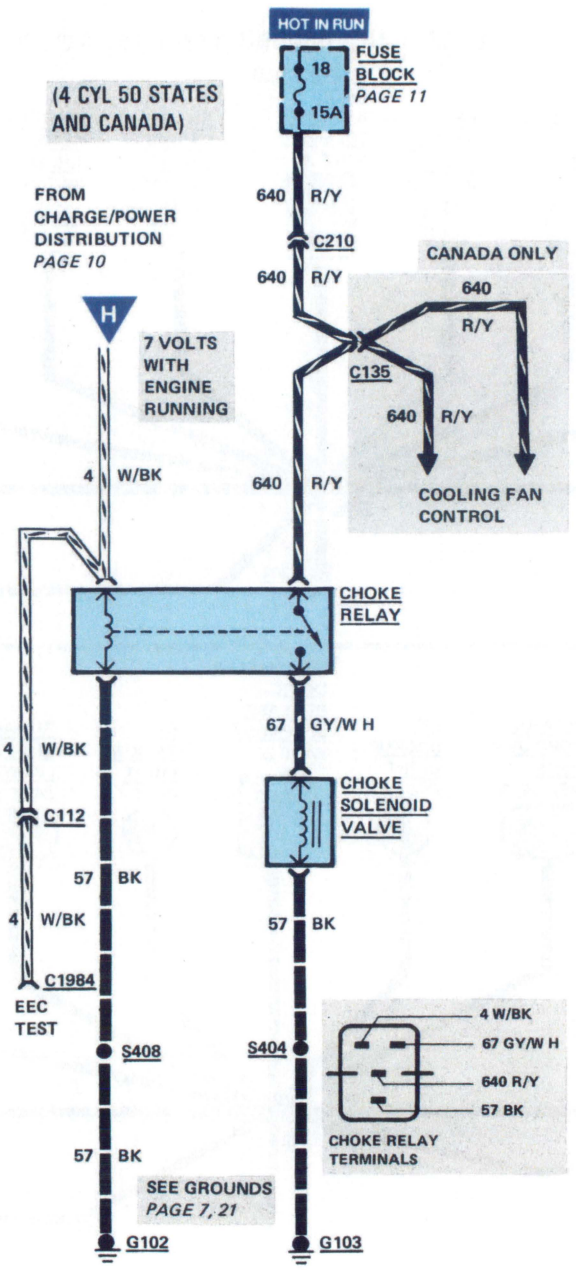

100% SATISFACTION GUARANTEED

BUY IT NOW!

Click Here To Order

PayPal American Express Discover MasterCard VISA

HOW THE CIRCUIT WORKS

With engine running, 7 volts from the alternator is applied to the **Choke Relay**. The contacts close, applying 12 volt power from **Fuse 18** to the **Choke Solenoid Valve**. The valve closes and shuts off vacuum to the carburetor butterfly release.

When the engine stops, 7 volts power is removed from the **Choke Relay**. The contacts open, and the **Choke Solenoid Valve** is de-energized. Vacuum passes to a diaphragm motor which allows the butterfly plate to close. This makes it easier to restart the engine.

TROUBLESHOOTING HINTS

CHOKE CONTROL DOESN'T WORK

- Check **Fuse 18**.
- Check that **G102** is clean and tight.
- Check operation of **Choke Relay**.
- Check for continuity to ground through **Choke Solenoid Valve**.

COMPONENT LOCATION

		Page-Figure	Color	Terminals
Choke Relay.....	RH fender apron near voltage regulator	87-1		
Choke Solenoid Valve.....	LH fender apron			
Connector C112	LH fender apron	25-2	BK	3
Connector C135	LH fender apron	25-2	GY	8
Connector C210	Under LH side of I/P on shake brake		GY	12
Connector 1984	Near ignition coil		GY	6
Ground G102	Top LH side of radiator support	33-1		
Ground G103	Top LH side of radiator support	33-1		
Splice S404	In 14290, near T/O to LH front side marker light			
Splice S408	In 14290, near T/O to RH front side marker light			

100% SATISFACTION GUARANTEED

BUY IT NOW!

Click Here To Order

PayPal American Express Discover MasterCard VISA



**WE SUPPORT VOLUNTARY
TECHNICIAN CERTIFICATION**



**Ford Parts and Service Division
Training and Publications Department**

100% SATISFACTION GUARANTEED

BUY IT NOW!

Click Here To Order 

0335-503-85