

1985 BRONCO / F150 / 350

# 1985 BRONCO/ F150/350

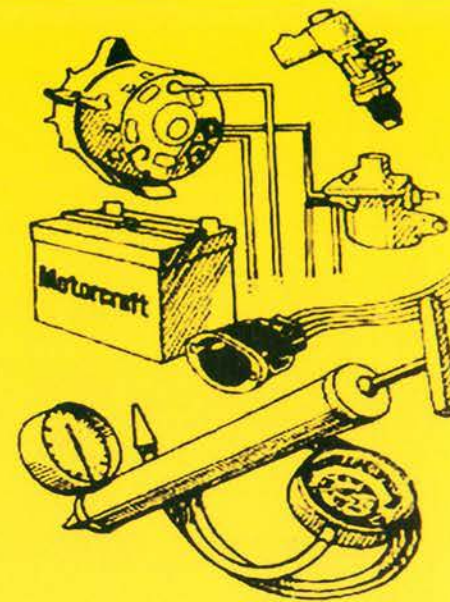

## Electrical & Vacuum Trouble- Shooting Manual

### DEMO

This DEMO contains only a few pages of the entire manual/product.

Not all Bookmarks work on the Demo, but they do on the full version.

#### Features:

- Searchable text
- Printable pages
- Bookmarked for easy navigation
- High Resolution images
- Zoom to see exact details
- Money back Guarantee
- Available on USB and eBook download

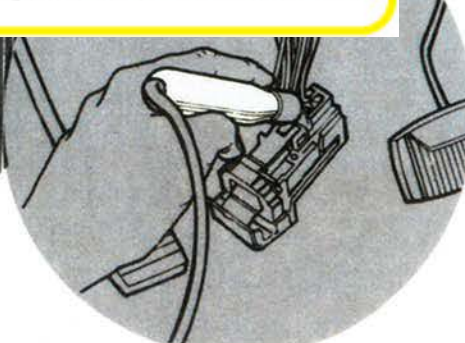

**100% SATISFACTION GUARANTEED**

**BUY IT NOW!**

**Click Here To Order**



**Ford**

Official  
Licensed  
Product

License #84356800



Copyright © 2023, Forel Publishing Company, LLC, Woodbridge, Virginia

All Rights Reserved. No part of this book may be used or reproduced in any manner whatsoever without written permission of Forel Publishing Company, LLC. For information write to Forel Publishing Company, LLC, Woodbridge, VA 22192

**1985 Bronco F150/350 Electrical & Vacuum  
Trouble-Shooting Manual (EVTM)  
EAN: 978-1-60371-408-2  
ISBN: 1-60371-408-1**

Forel Publishing Company, LLC  
Woodbridge, VA 22192  
Email: sales@ForelPublishing.com  
<https://www.ForelPublishing.com>



License #84356800

This publication contains material that is reproduced and distributed under a license from Ford Motor Company. No further reproduction or distribution of the Ford Motor Company material is allowed without the express written permission of Ford Motor Company.

---

## Note from the Publisher

This product was created from the original Ford Motor Company's publication. Every effort has been made to use the original scanned images, however, due to the condition of the material; some pages have been modified to remove imperfections.

---

## Disclaimer

Although every effort was made to ensure the accuracy of this book, no representations or warranties of any kind are made concerning the accuracy, completeness or suitability of the information, either expressed or implied. As a result, the information contained within this book should be used as general information only. The author and Forel Publishing Company, LLC shall have neither liability nor responsibility to any person or entity with respect to any loss or damage caused, or alleged to be caused, directly or indirectly by the information contained in this book. Further, the publisher and author are not engaged in rendering legal or other

advice, mechanical, electrical, or other expert assistance is required, the professional should be sought.



How to Use This Manual . . . . .	1
How to Find the Electrical Problem . . . . .	2,3
Symbols (Electrical) . . . . .	4
(Vacuum) . . . . .	136
How to Find the Vacuum Problem . . . . .	138
Instrument Panel (Back View) . . . . .	67
Component Testing	
Introduction . . . . .	150
Main Light Switch . . . . .	150
Ignition Switch . . . . .	151
Turn Switch . . . . .	152
Windshield Wiper/Washer Switch . . . . .	153
Interval Wiper/Washer Switch . . . . .	154
A/C-Heater Function Selector . . . . .	155
A/C-Heater Blower Switch . . . . .	156



A/C-Heater . . . . .	145-149
Auxiliary Battery . . . . .	19-21
Brake Warning Indicator . . . . .	89
Carburetor Circuits . . . . .	52-55
Charge (Gasoline) . . . . .	14-18
(Diesel) . . . . .	22-26
Choke Heater . . . . .	15,17
Cigar Lighter . . . . .	112,113
Clock . . . . .	114,115
Coolant Temperature Gage . . . . .	98,104,105
Diesel Glow Plug Control . . . . .	47-51
Digital Clock . . . . .	114,115
Electric Fuel Pump Control . . . . .	102,109
Electronic Engine Control . . . . .	56-65
Feedback Carburetor Control . . . . .	56
Four-Wheel Drive Indicator . . . . .	94,95
Fuel Gage (Diesel) . . . . .	110
(Gasoline) . . . . .	98,104,106
Funk Selector (Diesel) . . . . .	110,111
(Gasoline) . . . . .	104-109
(Horn) . . . . .	12,13
(Lights) . . . . .	110,111
(Wiper/Washer) . . . . .	98,99
(Windshield) . . . . .	5-11
(Windshield) . . . . .	66-67

Heater . . . . .	144
Horn . . . . .	112,113
Ignition . . . . .	27-35
Instrument Cluster Terminals . . . . .	87
Instrument Illumination . . . . .	87-89
Lamps On Warning . . . . .	83-85
Lamps	
Backup . . . . .	81-82
Cargo . . . . .	83-85
Dome . . . . .	83-85
Exterior . . . . .	70
Hazard . . . . .	
Headlamps . . . . .	66,67
Instrument Illumination . . . . .	87,88
License . . . . .	70,71
Map . . . . .	83,84
Marker . . . . .	70-72
Park . . . . .	70,71
Radio Illumination . . . . .	87
Stop . . . . .	
Tail (Rear Park) . . . . .	70,71
Turn . . . . .	
Main Light Switch . . . . .	66
Power Distribution (Diesel) . . . . .	23-26
(Gasoline) . . . . .	15-18
Power Door Locks . . . . .	127,128
Power Mirrors . . . . .	129,130
Power Windows . . . . .	120,121
Printed Circuit Board Connectors . . . . .	
Radio (stereo) (Electronic) . . . . .	133
(Stereo) . . . . .	131,132
Rear Window Defrost . . . . .	123-125
Seatbelt Warning . . . . .	90,91
Shift Indicator . . . . .	96,97
Speed Control . . . . .	140-143
Start (Diesel) . . . . .	47-49
(Gasoline) . . . . .	27-36
Tachometer . . . . .	98
Tailgate Power Window . . . . .	123,124
Trailer . . . . .	134,135
Vacuum Distribution . . . . .	136,138

Warning Indicators (Diesel) . . . . .	92,93
(Gasoline) . . . . .	90-91
Windshield Wiper/Washer . . . . .	116,117
Wiper/Washer (Interval) . . . . .	118,119

### IMPORTANT SAFETY NOTICE

*Appropriate service methods and proper repair procedures are essential for the safe, reliable operation of all motor vehicles, as well as the personal safety of the individual doing the work. This Manual provides general directions for accomplishing service and repair work with tested, effective techniques. Following them will help assure reliability.*

*There are numerous variations in procedures, techniques, tools, and parts for servicing vehicles; as well as in the skill of the individual doing the work. This Manual cannot possibly anticipate all such variations and provide advice or cautions as to each. Accordingly, anyone who departs from the instructions provided in this Manual must first establish that he compromises neither his personal safety nor the vehicle integrity by his choice of methods, tools or parts.*

**100% SATISFACTION GUARANTEED**

**BUY IT NOW!**

**Click Here To Order**

PayPal American Express Discover MasterCard VISA

The purpose of this manual is to show electrical and vacuum circuits of these vehicles in a clear and simple fashion to make troubleshooting easier. With each circuit is a description of *How the Circuit Works* and some *Troubleshooting Hints*. A *Component Location* chart lists components, connectors, and grounds in that circuit. The chart includes a description of where each item is located, and references to pictures in the manual.

**Wiring Diagrams** give a schematic picture of when and how the circuit is powered, what the current path is to circuit components, and how the circuit is grounded. Each circuit component is named (underlined titles). Wire and connector colors are listed (standard Ford color abbreviations are used):

## COLOR ABBREVIATIONS

BL	Blue	N	Natural
BK	Black	O	Orange
BR	Brown	PK	Pink
DB	Dark Blue	P	Purple
DG	Dark Green	R	Red
GR	Green	T	Tan
GY	Gray	W	White
LB	Light Blue	Y	Yellow
LG	Light Green		

Where two colors are shown for a wire, the first color is the basic color of the wire. The second color is the dot, hash, or stripe marking. If D or H is given, the second color is for dot or hash marks. If there is no letter after the color, the wire has a stripe.

**Connector end views** of switches and other components are shown to help with bench testing. The views show the harness wire colors that connect to the mating terminals. Connector colors and locations are shown in the *Component Location* chart. Two-color listings indicate separate colors for each connector half.

**Components** which work together are shown together. For example, all electrical components used in any circuit are shown on one diagram. The circuit breaker or fuse is shown at the top of the page. All wires, connectors, splices, switches, and motors are shown in the flow of current to ground at the bottom of the page. Notes are included which describe how switches and other components work. If a component is used in several different circuits, it is shown in several places. For example, the **Main Light Switch** is an electrical part of many circuits, and is repeated on many pages. In some cases, however, a component may seem, by its name, to belong on a page where it has no electrical connection. For example, **Radio Illumination** is electrically part of **Instrument Illumination**. Since it has no electrical connection at all with the actual **Radio** circuit, it is not shown on the **Radio** page.

*Troubleshooting Hints* point the technician in a general direction, but are not intended as a step-by-step procedure. Ignition troubleshooting is an exception to this. It includes a step-by-step procedure of basic quick checks to locate some of the more common **Ignition System** problems. Read the Shop Manual for more detailed repair procedures.

The **Grounds** pages show detailed views of multiple component ground points. This is useful for checking interconnections among the ground circuits of different diagrams.

**Notes, Cautions, and Warnings** appear in boxes on text pages and contain important vehicle and mechanic safety information.

Notes give added information to help complete a particular procedure. Cautions are included to prevent making an error that could damage the vehicle. Warnings highlight areas where carelessness can cause personal injury. The following list contains some general **Warnings** that should be followed when working on a vehicle.

- Always wear safety glasses for eye protection.
- Use safety stands whenever a procedure requires being under a vehicle.
- Be sure that the **Ignition Switch** is always in the OFF position, unless otherwise required by the procedure.
- Set the parking brake when working on any vehicle. An automatic transmission should be in PARK. A manual transmission should be in NEUTRAL.
- Operate the engine only in a well-ventilated area to avoid the danger of carbon monoxide.
- Keep away from moving parts when the engine is running, especially the fan and belts.
- To prevent serious burns, avoid contact with hot metal parts such as the radiator, exhaust manifold, tail pipe, catalytic converter, and muffler:
- Do not allow flame or sparks near the battery. Gases are always present in and around the battery cell. An explosion could occur.
- Do not smoke.
- To avoid injury, always remove rings, watches, loose hanging jewelry, and loose clothing.

# 2 HOW TO FIND THE ELECTRICAL PROBLEM

## TROUBLESHOOTING STEPS

These six steps present an orderly method of troubleshooting:

### Step 1. Verify the problem.

- Operate the complete system and see all symptoms for yourself in order to:
  - check the accuracy and completeness of the customer's complaint.
  - learn more that might give a clue to the nature and location of the problem.

### Step 2. Narrow the problem.

- Using this manual, narrow down the possible causes and locations of the problem in order to more quickly find the exact cause.
- Read the description of *How the Circuit Works* and study the wiring diagram. You should then know enough about the circuit operation to figure out where to check for this trouble.

### Step 3. Test the cause.

- Use electrical test procedures to find the specific cause of the symptoms.
- *Troubleshooting Hints* will give some helpful ideas.
- The *Component Location* charts and the pictures will help you find components, grounds, and connectors.

### Step 4. Verify the cause.

- Confirm the fact that you have found the correct cause through operating the parts of the circuit you think are good.

### Step 5. Make the repair.

Repair or replace the faulty component.

### Step 6. Verify the repair.

and check symptoms, any new

special test See the

*Shop Manual* and other service books for details. You will find the circuits in this manual to be helpful with these special tests.

## TROUBLESHOOTING TOOLS

### JUMPER WIRE

This is a test lead used to connect two points of a circuit. A **Jumper Wire** can complete a circuit by bypassing an open.

**Uses:** Bypassing Switches or Open Circuits

### WARNING

*Never use a jumper wire across loads (motors, etc.) connected between hot and ground. This direct battery short may cause injury or fire.*

### VOLTMETER

A DC **Voltmeter** measures circuit voltage. Connect negative (- or black) lead to ground, and positive (+ or red) lead to voltage measuring point.

### OHMMETER

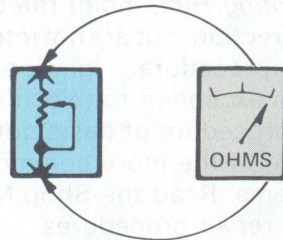

Figure 1— Resistance Check

An **Ohmmeter** shows the resistance between two connected points (Figure 1).

### TEST LIGHT

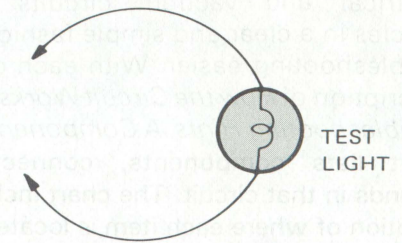

Figure 2— Test Light

A **Test Light** is a 12-volt bulb with two test leads (Figure 2).

**Uses:** Voltage Check. Short Check

### SELF-POWERED TEST LIGHT

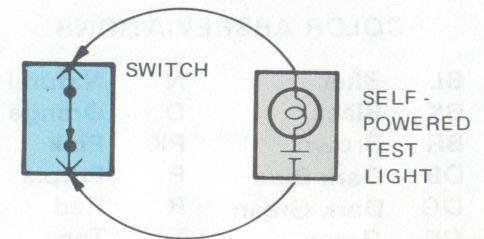

Figure 3— Continuity Check

The **Self-Powered Test Light** is a bulb, battery and set of test leads wired in series (Figure 3). When connected to two points of a continuous circuit, the bulb glows.

**Uses:** Continuity Check. Ground Check

### CAUTION

*When using a self-powered test light or ohmmeter, be sure power is off in circuit during testing. Hot circuits can cause equipment damage and false readings.*

**100% SATISFACTION GUARANTEED**

**BUY IT NOW!**

**Click Here To Order**

PayPal American Express Discover Novus MasterCard VISA

## TROUBLESHOOTING CHECKS

### SWITCH CIRCUIT CHECK

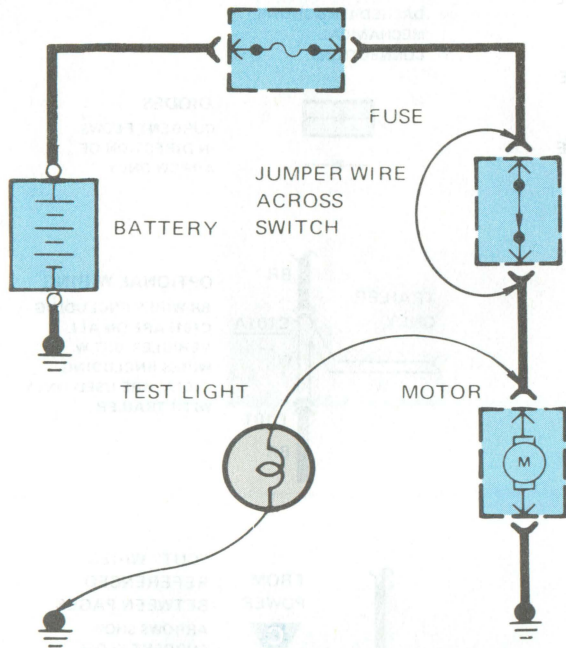

Figure 4—Switch Circuit Check and Voltage Check

In a bad circuit with a switch in series with the load, jumper the terminals of the switch to power the load. If jumping the terminals powers the circuit, the switch is bad (Figure 4).

### CONTINUITY CHECK (Locating open circuits)

With power off, connect one lead of **Self-Powered Test Light** or **Ohmmeter** to each end of circuit (Figure 3). Light will glow if circuit is closed. Switches and fuses can be checked in the same way.

### SHORT CHECK (short to ground)

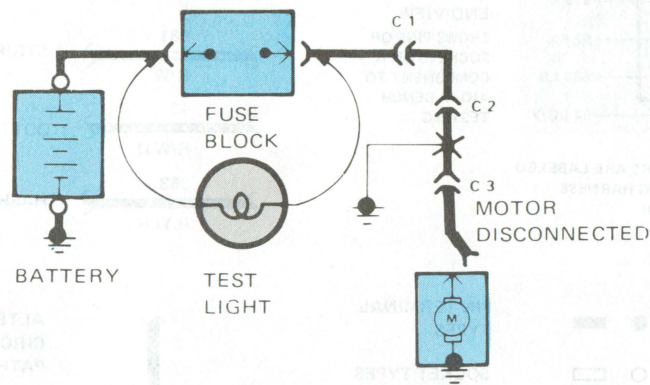

Figure 5—Short Check

A fuse that repeatedly blows is usually caused by a short to ground. It's important to be able to locate such a short quickly (Figure 5).

- 1) Turn off everything powered through the fuse.
- 2) Disconnect other loads powered through the fuse:
  - Motors: disconnect motor connector.
  - Lights: remove bulbs.
- 3) Turn **Ignition Switch** to RUN (if necessary) to power fuse.
- 4) Connect one **Test Light** lead to hot end of blown fuse. Connect other lead to ground. Bulb should glow showing power to fuse. *(This step is just a check to be sure you have power to the circuit.)*
- 5) Disconnect the **Test Light** lead from ground and reconnect it to the load side of the fuse.
  - If the **Test Light** is off, the short is in the disconnected equipment.
  - If the **Test Light** goes on, the short is in the wiring. You must find the short by disconnecting the circuit connectors one at a time until the **Test Light** goes out. For example: with a ground at X, the bulb goes out when C1 or C2 is disconnected, but stays on after disconnecting C3. This

means the ground is between C2 and C3.

### "GOOD GROUND" CHECK

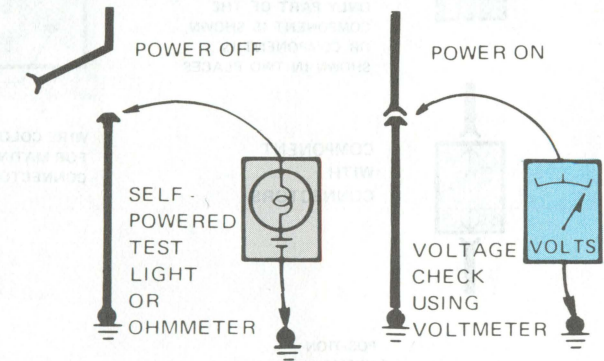

Figure 6 – Grounds Checks

Turn on power to circuit. Perform Voltage Check between suspected bad ground and frame. Any voltage means ground is bad.

Turn off power to circuit. Connect one lead of **Self-Powered Test Light** or **Ohmmeter** to wire in question, and the other to known ground. If bulb glows, circuit ground is OK (Figure 6).

## TROUBLESHOOTING HINTS

The circuit schematics in this manual are designed to make it easy to identify common points in circuits. This knowledge can help narrow the problem to a specific area. For example, if several circuits fail at the same time, check for a common power or ground connection. (See *Power Distribution* or *Grounds*). If part of a circuit fails, check the connections between the part that works and the part that doesn't work.

For example, if low beam headlights work but high beams and the indicator light don't work, then power and ground paths must be good. Since the dimmer switch is the component which switches this power to the high beam lights and indicator, it is most likely the cause of failure.

**100% SATISFACTION GUARANTEED**

**BUY IT NOW!**

**Click Here To Order**

PayPal, American Express, Discover, MasterCard, VISA

# 4 ELECTRICAL SYMBOLS

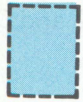

**DASHED COMPONENT BOX**  
ONLY PART OF THE COMPONENT IS SHOWN, OR COMPONENT IS SHOWN IN TWO PLACES

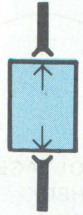

**COMPONENT WITH CONNECTORS**



**POSITION NUMBER**  
**FUSE**



**POSITION NUMBER**  
**CIRCUIT BREAKER**

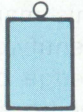

**SCREW TERMINAL ON COMPONENT**

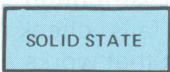

**SEALED ELECTRONIC COMPONENT**  
ANY CIRCUITRY SHOWN INSIDE THE BOX IS A FUNCTIONAL

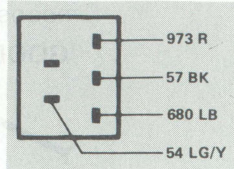

**WIRE COLORS ARE LABELED FOR MATING HARNESS CONNECTOR**

**COMPONENT CONNECTOR END VIEW**  
SHOWS PINS OR SOCKETS ON A COMPONENT TO AID IN BENCH TESTING



**PIN TERMINAL TYPES**  
**SOCKET TYPES**

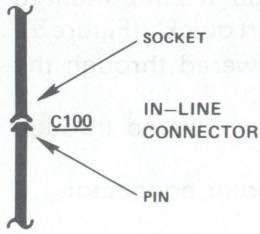

**IN-LINE CONNECTOR**

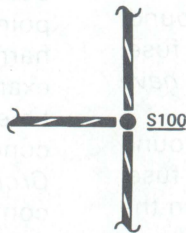

**SPLICE OR CRIMP CONNECTION.**  
MOST ARE BUILT INTO HARNESS AND ARE NOT ACCESSIBLE.

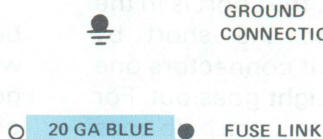

**GROUND CONNECTION**

**FUSE LINK**

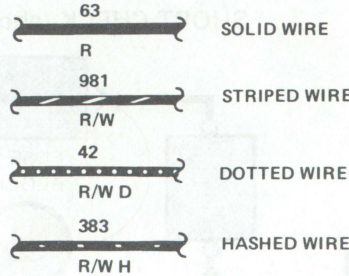

**SOLID WIRE**

**STRIPED WIRE**

**DOTTED WIRE**

**HASHED WIRE**

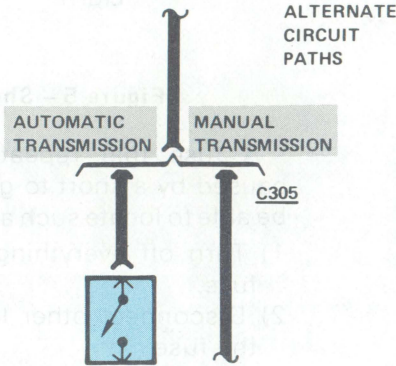

**ALTERNATE CIRCUIT PATHS**

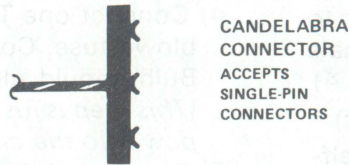

**CANDELABRA CONNECTOR**  
ACCEPTS SINGLE-PIN CONNECTORS

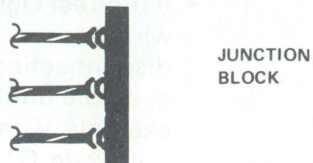

**JUNCTION BLOCK**

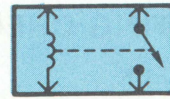

**RELAY**  
CONTACTS CLOSE WITH CURRENT THROUGH COIL

**DASHED LINE SHOWS MECHANICAL CONNECTIONS**



**DIODES**  
CURRENT FLOWS IN DIRECTION OF ARROW ONLY

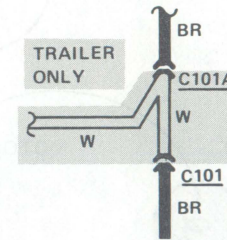

**OPTIONAL WIRING**  
BR WIRES (INCLUDING C101) ARE ON ALL VEHICLES, BUT W WIRES (INCLUDING C101A) ARE USED ONLY WITH TRAILER

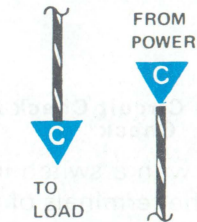

**"CUT" WIRES REFERENCED BETWEEN PAGES**  
ARROWS SHOW CURRENT FLOW FROM POWER TO GROUND



**"REFERENCE" WIRES**  
COMPLETE WIRING SHOWN ON ANOTHER PAGE

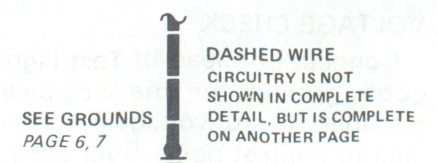

**DASHED WIRE CIRCUITRY IS NOT SHOWN IN COMPLETE DETAIL, BUT IS COMPLETE ON ANOTHER PAGE**

**100% SATISFACTION GUARANTEED**

**BUY IT NOW!**

**Click Here To Order**

BRONCO

INSTRUMENT PANEL GROUND

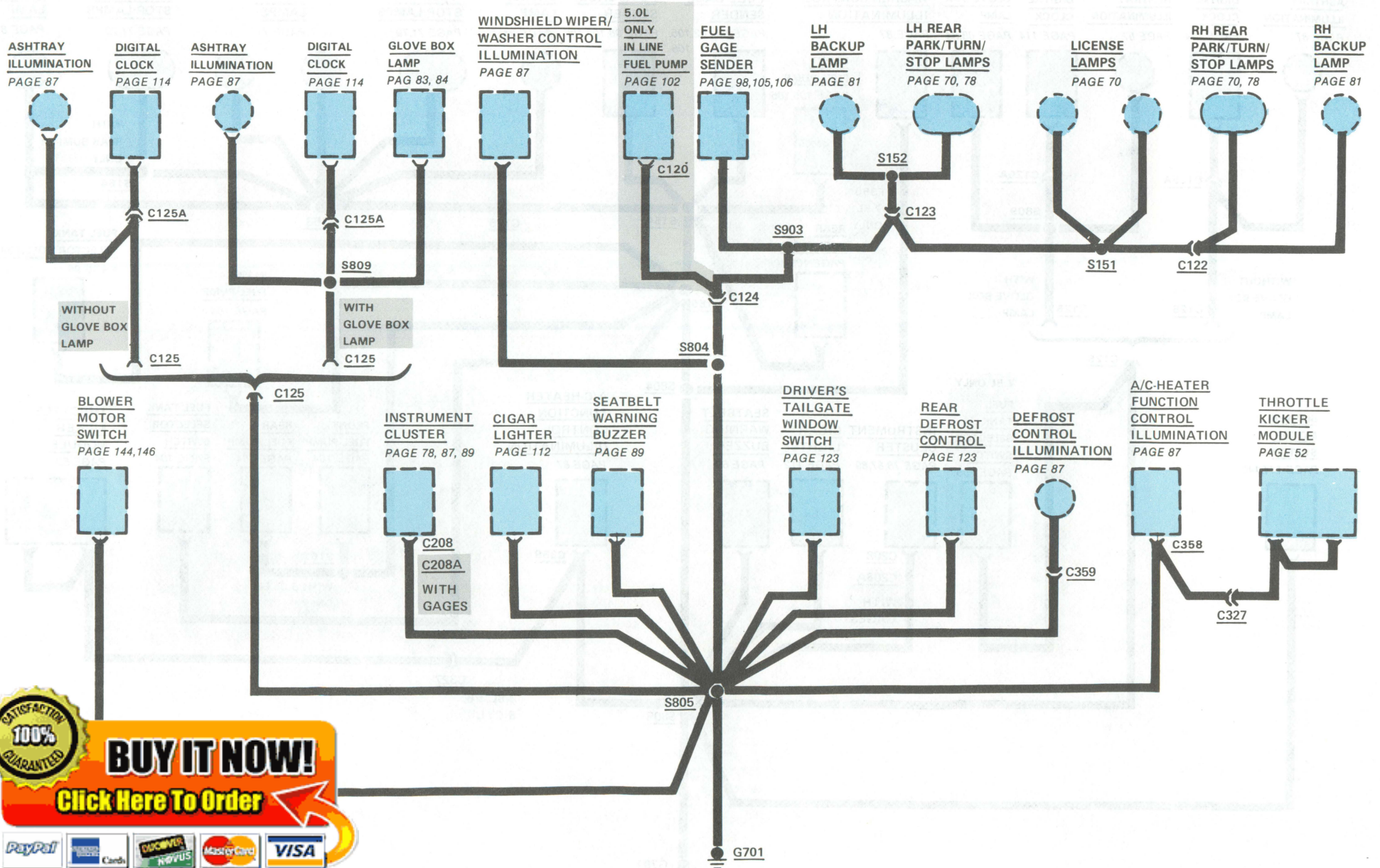

**100% SATISFACTION GUARANTEED**

**BUY IT NOW!**

**Click Here To Order**

PayPal, American Express, Discover, MasterCard, VISA

F150-350

## GASOLINE ENGINES

## INSTRUMENT PANEL GROUND

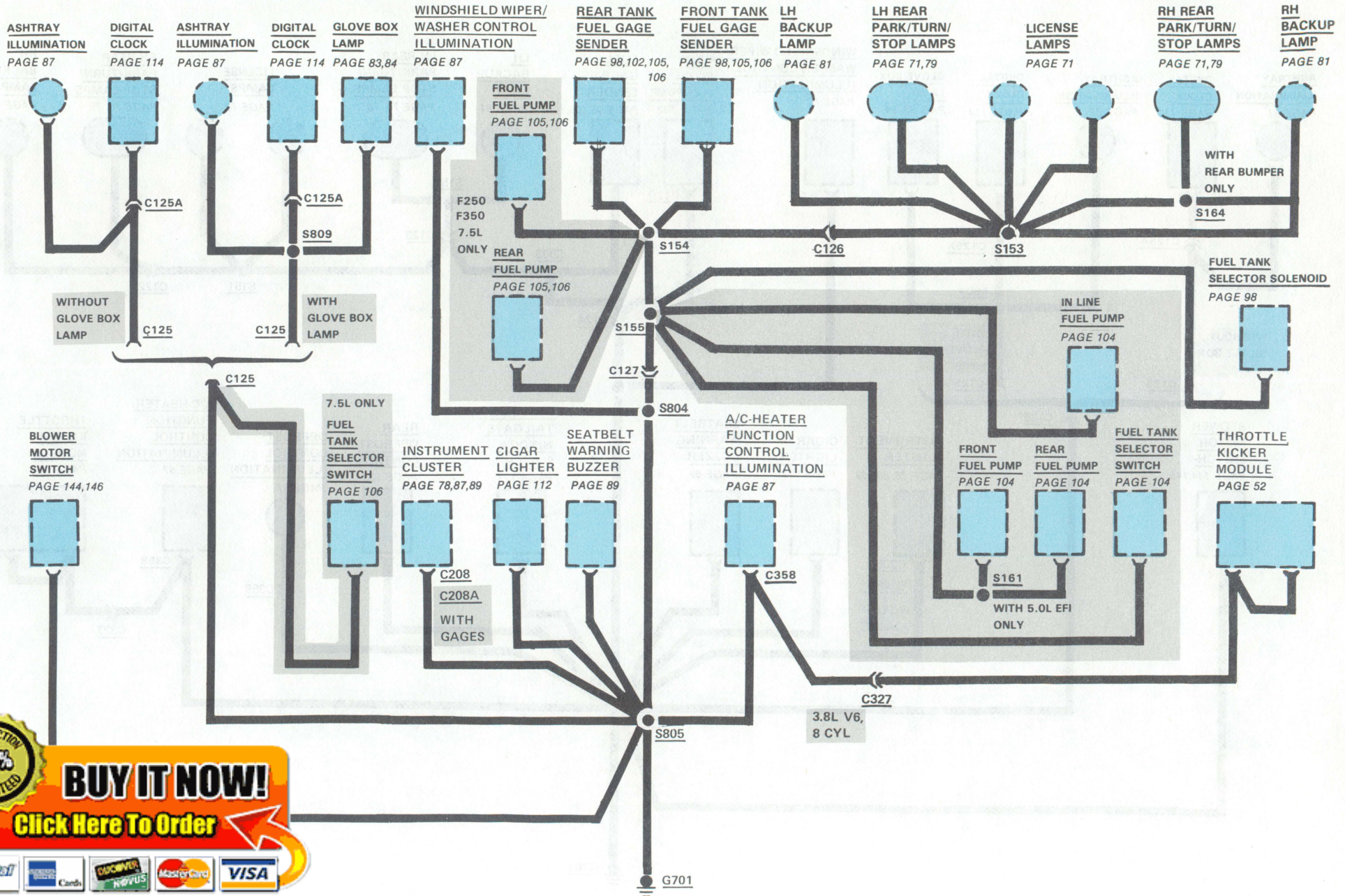

**100% SATISFACTION GUARANTEED**

**BUY IT NOW!**

**Click Here To Order**

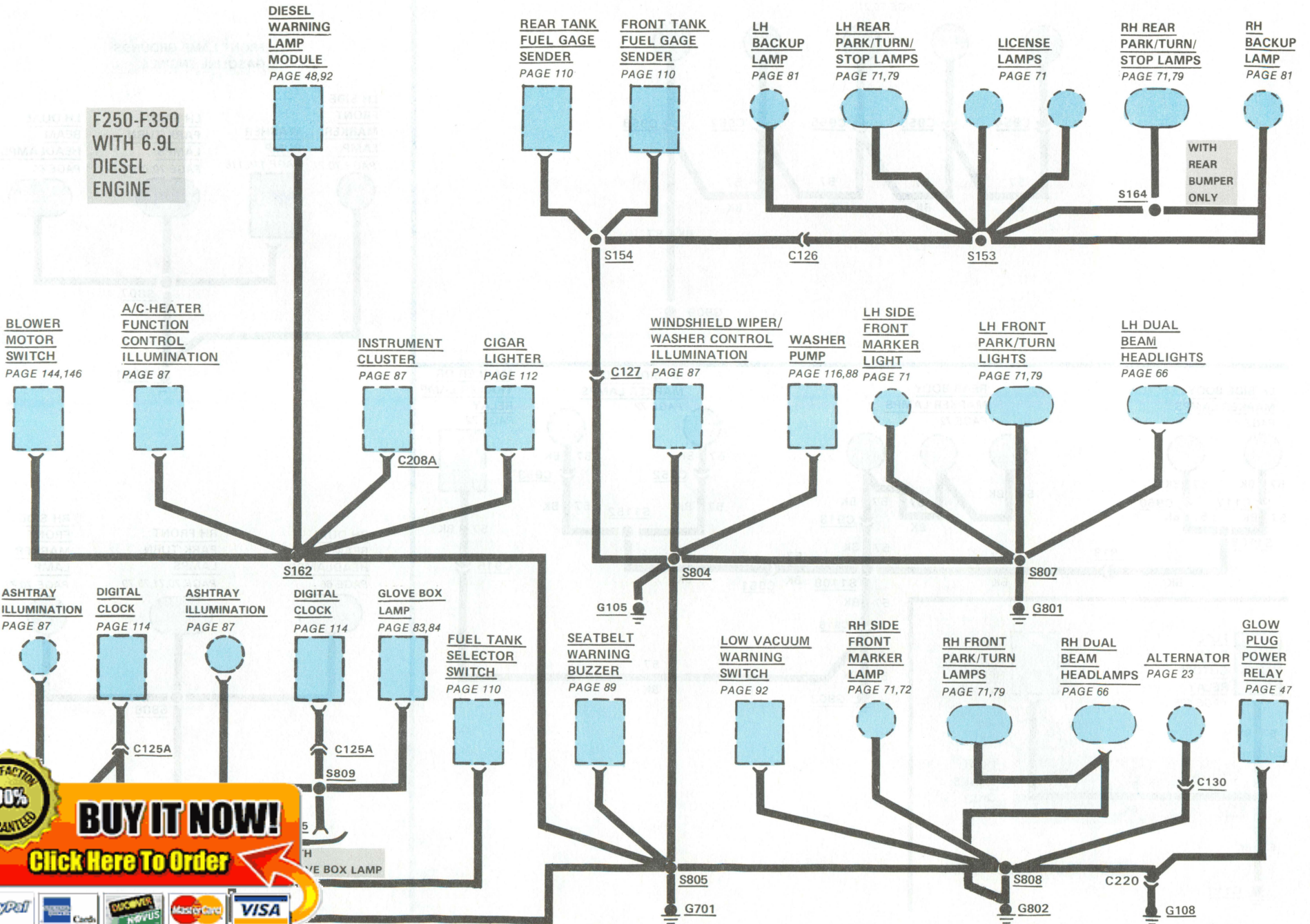

**BUY IT NOW!**

**Click Here To Order**



# 8 GROUNDS (G112, G801, G903, G909)

## CAB MARKER LAMPS PAGE 70,71

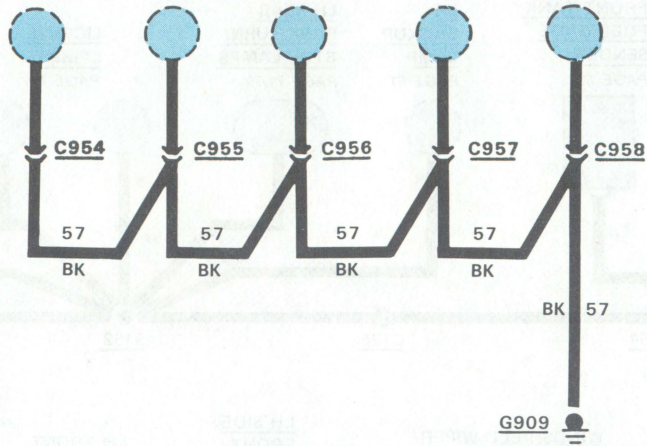

## FRONT LAMP GROUNDS GASOLINE ENGINES

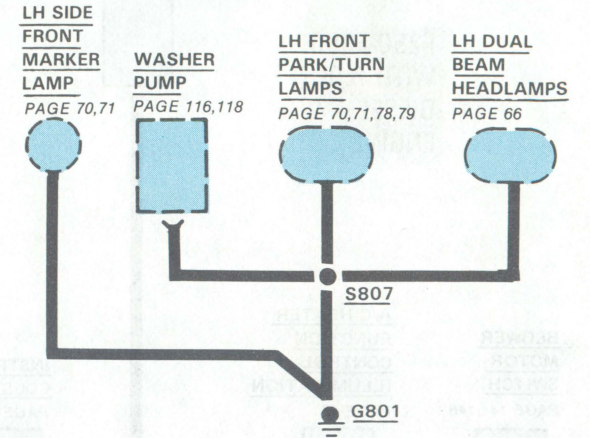

## LH SIDE BODY MARKER LAMPS PAGE 72

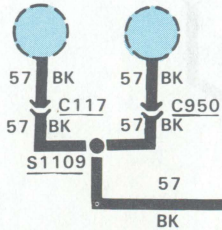

## REAR BODY MARKER LAMPS PAGE 72

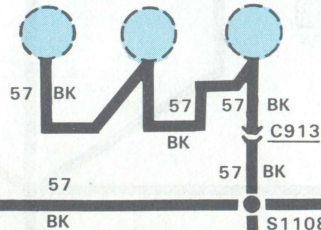

## RH SIDE BODY MARKER LAMPS PAGE 72

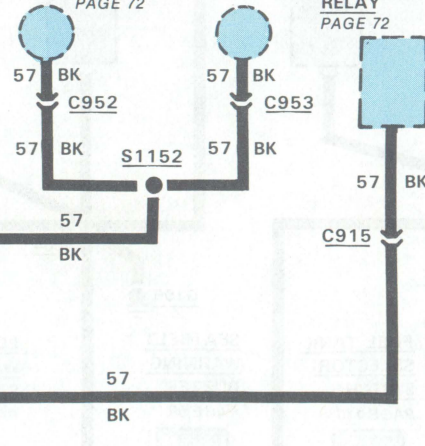

## MARKER OR TRAILER LAMP RELAY PAGE 72

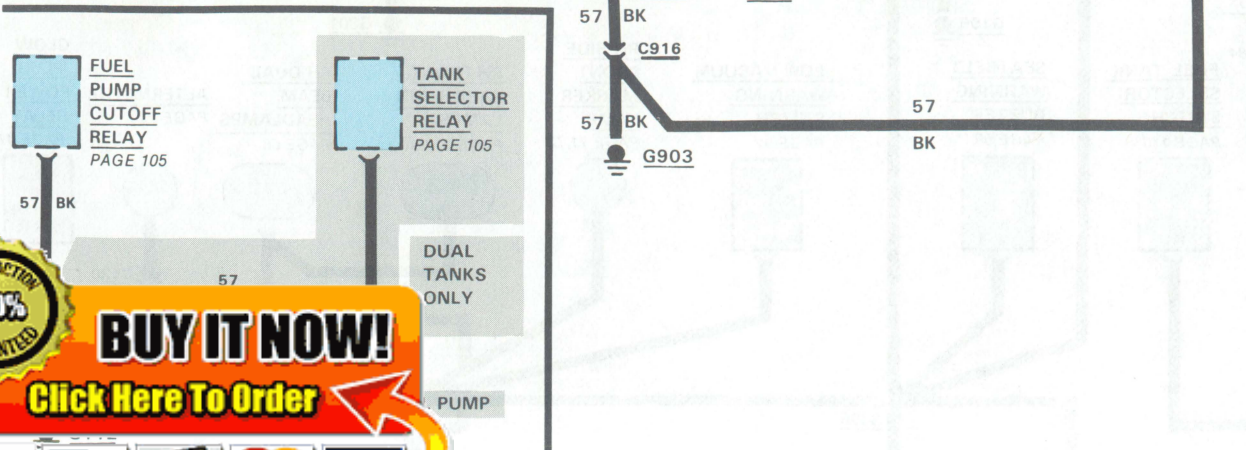

## RH DUAL BEAM HEADLAMPS PAGE 66

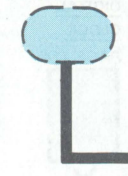

## RH FRONT PARK/TURN LAMPS PAGE 70,71,78,79

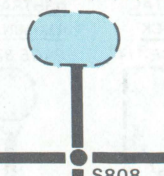

## RH SIDE FRONT MARKER LAMP PAGE 70,71



**100% SATISFACTION GUARANTEED**

**BUY IT NOW!**

**Click Here To Order**

PayPal, Discover, MasterCard, VISA

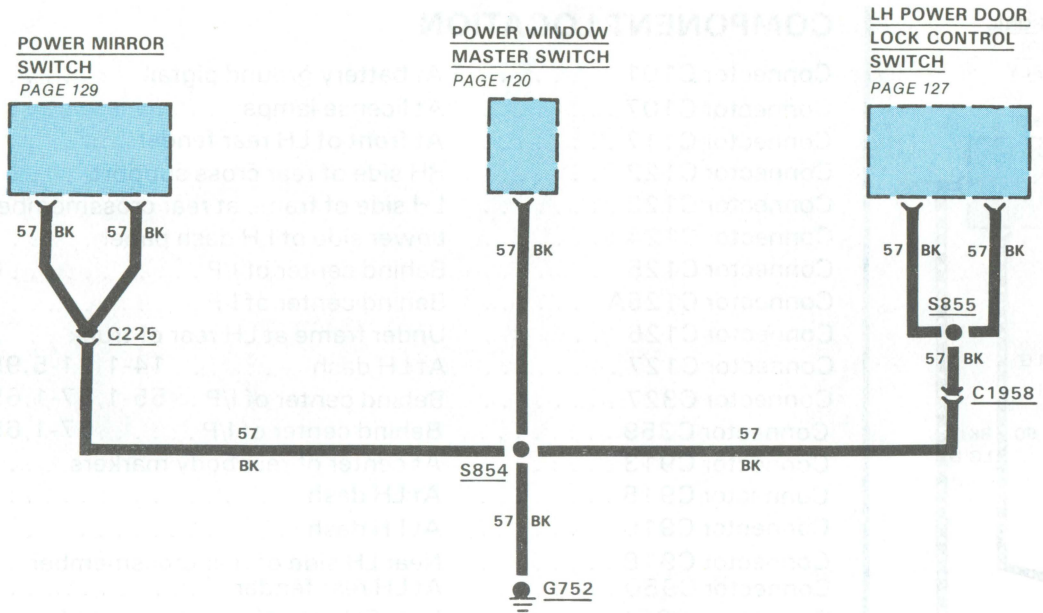

**100% SATISFACTION GUARANTEED**

**BUY IT NOW!**

**Click Here To Order**

# 10 GROUNDS (G203)

EEC ONLY

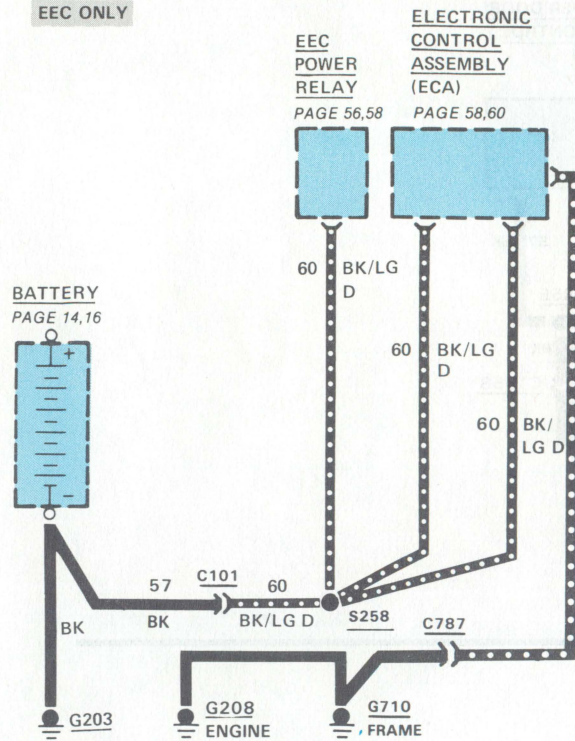

DIESEL

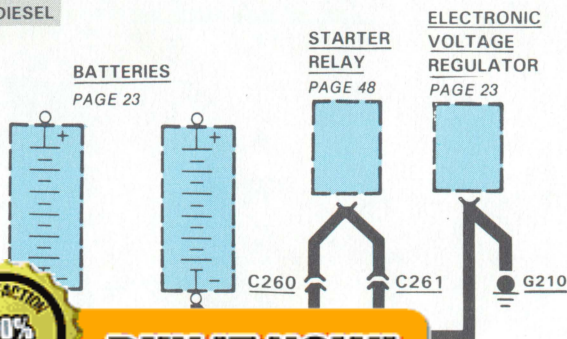

## COMPONENT LOCATION

		Page-Figure	Color	Terminals
Connector C101	At battery ground pigtail		GY	1
Connector C107	At license lamps	76-3	BR	1
Connector C117	At front of LH rear fender	76-2	BR	2
Connector C122	RH side of rear cross support	75-3	BK	4
Connector C123	LH side of frame at rear crossmember	125-3	NAT	4
Connector C124	Lower side of LH dash panel	21-5	BK	8
Connector C125	Behind center of I/P	67-1,68-1,69-1	GY	8
Connector C125A	Behind center of I/P	69-1,114-1	GY	8
Connector C126	Under frame at LH rear of truck	76-3	BR	1
Connector C127	At LH dash	14-1,21-5,95-1,97-1,116-1	GY	4
Connector C327	Behind center of I/P	55-1,67-1,69-1,96-1,125-2	GY	3
Connector C359	Behind center of I/P	67-1,69-1,96-1,125-2	GR	2
Connector C913	At center of rear body markers	75-2	GR	2
Connector C915	At LH dash	14-1,133-1	BK	2
Connector C916	At LH dash	76-3	BK	2
Connector C918	Near LH side of rear crossmember	76-3	GY	2
Connector C950	At LH rear fender	76-2	BR	2
Connector C951	Near RH side of rear crossmember	76-2	BR	2
Connector C952	At front of RH rear fender	76-2	BR	2
Connector C953	At rear of RH rear fender	76-2	BR	2
Connector C954	In forward part of roof cab	77-2	BK	2
Connector C955	In forward part of roof cab	77-2	BK	2
Connector C956	In forward part of roof cab	77-2	BK	2
Connector C957	In forward part of roof cab	77-2	BK	2
Connector C958	In forward part of roof cab	77-2	BK	2
Ground G108	At glow plug relay	22-1		
Ground G112	Near fuel pump cutoff relay	109-1		
Ground G203	RH side of engine	21-3,26-3,86-1		
Ground G210	At electronic voltage regulator	22-1		
Ground G105	At water in fuel switch (diesel)			
Ground G701	Behind I/P near RH side of radio	67-1,68-1,69-1,148-1		
Ground G752	LH Door rear power window motor	121-1		
Ground G801	On LH inner fender behind headlamps	66-1		
Ground G802	On RH inner fender behind headlamp	14-3,22-1		
Ground G903	At LH side of rear crossmember	76-3		
Ground G909	At lower LH cowl access hole	75-4		

(Continued on next page)

**100% SATISFACTION GUARANTEED**

**BUY IT NOW!**

[Click Here To Order](#)

PayPal | American Express | Discover | MasterCard | VISA

## HOW THE CIRCUIT WORKS

The ground circuits shown here are complete and connect several components together to screw terminal ground points. On other pages only parts of these circuits may be shown. Partial ground circuits are shown dashed on those pages.

All simple or component ground circuits are shown on the individual circuit pages and are complete on those pages.

All ground wires are **57 BK** unless otherwise noted.

## COMPONENT LOCATION

(Continued from previous page)

Page-  
Figure

Color Terminals

Splice S112	Near fuel pump cutoff relay T/O
Splice S151	Near license plate T/O
Splice S152	Near LH backup lamp T/O
Splice S153	Near license plate T/O
Splice S154	Near front fuel gage sender T/O
Splice S155	Near fuel tank selector valve solenoid T/O
Splice S161	Near front fuel pump T/O
Splice S162	Near heater control switch T/O
Splice S164	Near license plate T/O
Splice S804	Near parking break switch T/O
Splice S805	Near cigar lighter T/O
Splice S807	Near LH front headlamp T/O
Splice S808	Near RH park lamp T/O
Splice S809	Near ashtray illumination T/O
Splice S854	Near LH master window control T/O
Splice S855	Near LH master window control T/O
Splice S903	Near fuel gage sender and pump T/O
Splice S1108	Near rear marker lamp T/O
Splice S1109	Near LH front side marker lamp T/O
Splice S1152	Near RH front side marker lamp T/O

COLOR CODE	
20 GA	BLUE
18 GA	RED
16 GA	ORANGE
14 GA	GREEN

**100% SATISFACTION GUARANTEED**

**BUY IT NOW!**

**Click Here To Order**

# 12 FUSE PANEL/CIRCUIT PROTECTION

## REPLACEMENT OF FUSES/ CIRCUIT BREAKERS

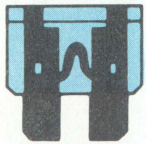

GOOD FUSE

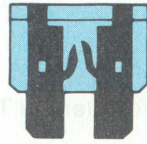

BLOWN FUSE

Fuses are mounted either in the **Fuse Panel** or in-line. They are identified by the numbered value in amperes, and by a color code. Some positions may have either a fuse with adapter or a circuit breaker. Be sure to replace a fuse or circuit breaker with the same kind of unit and with the same ampere rating. Remove fuses in order to check them.

## CIRCUIT BREAKER OPERATION

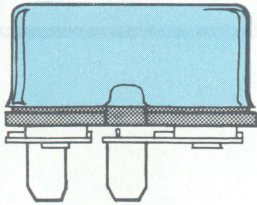

EXTERNAL  
SIDE VIEW

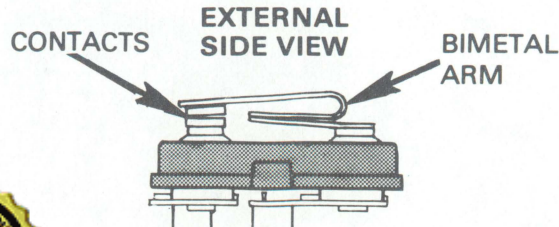

CONTACTS

BIMETAL  
ARM

Some circuits are protected by circuit breakers. (Abbreviated "c.b." in fuse chart.) They can be **Fuse Panel** mounted or in-line. Like fuses, they are rated in amperes.

Each circuit breaker conducts current through an arm made of two types of metal bonded together (bimetal arm). If the arm starts to carry too much current, it heats up. As one metal expands faster than the other, the arm bends, opening the contacts. Current flow is broken. In the cycling type, the arm cools and straightens out. This closes the circuit again. This cycle repeats as long as the overcurrent exists, with power applied.

In the non-cycling type, there is also a coil wrapped around the bimetal arm. When an overcurrent exists and the contacts open, a small current passes through the coil. This current through the coil is not large enough to operate a load, but it does heat up both the coil and bimetal arm. This keeps the arm in the open position until power is removed.

CONTACTS BIMETAL ARM COIL

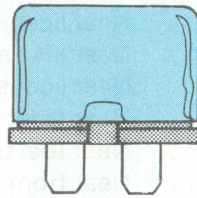

EXTERNAL  
SIDE VIEW

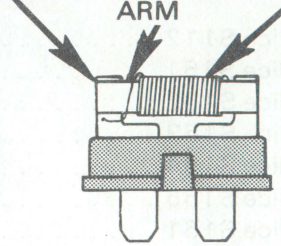

INTERNAL  
SIDE VIEW

## Non-Cycling Fuse Block Type

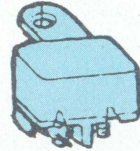

## Cycling In-Line Type

## FUSE LINKS

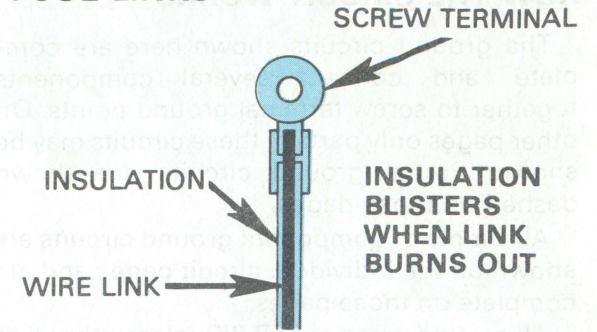

INSULATION

WIRE LINK

SCREW TERMINAL

INSULATION  
BLISTERS  
WHEN LINK  
BURNS OUT

The fuse link is a short length of wire smaller in gage than the wire in the protected circuit. The wire is covered with a thick non-flammable insulation. An overload causes the link to heat and the insulation to blister. If the overload remains, the link will melt, causing an open circuit. The links are color coded for wire size as follows:

## COLOR CODE

BLUE	20 GA
RED	18 GA
ORANGE	16 GA
GREEN	14 GA

When replacing, make tight crimp joints or hot solder joints for good connections.

## DIODES



Diodes are electrical devices that permit current to flow in one direction only. The current flows in the direction indicated by the arrow.



**BUY IT NOW!**

**Click Here To Order**



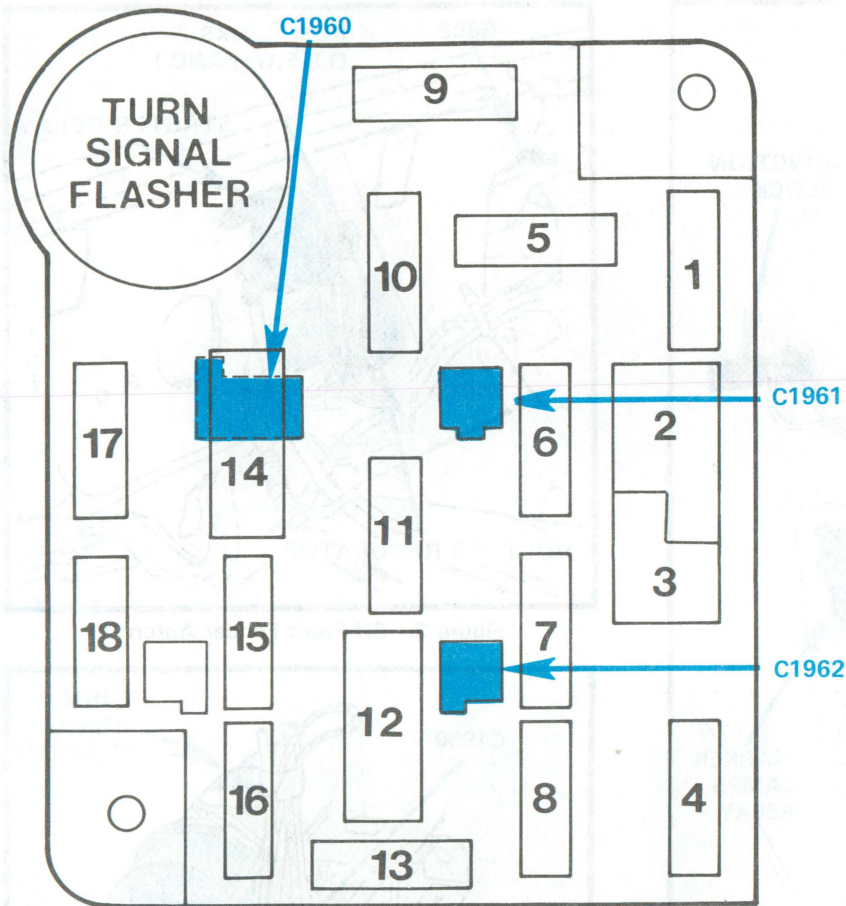

Figure 1 - Fuse Panel

Fuse Value Amps	Color Code
4	Pink
5	Tan

Fuse Position	Amps	Circuits Protected
1	15	Stop/Hazard Lamps; Speed Control
2	--	(Not used)
3	--	(Not used)
4	15	Exterior Lamps; Instrument Illumination
5	15	Turn Lamps; Backup Lamps
6	15	Speed Control; 4-Wheel Drive Indicator; Auxiliary Battery Control; Digital Clock; Rear Window Defrost; Feedback Carburetor Control (4.9L)
7	--	(Not used)
8	15	Courtesy, Dome, Cargo Lamps; Warning Buzzer
9	30	Heater; A/C-Heater
10	--	(Not used)
11	15	Radio
12	{ 25 30 c.b.	Tailgate Power Window; Power Mirrors Power Door Locks
13	--	(Not used)
14	{ 25 20 c.b.	Tailgate Power Window Power Windows
15	10	Auxiliary Fuel Tank Selector
16	20	Horn; Cigar Lighter
17	5	Instrument Illumination, Digital Clock
18	15	Seatbelt Buzzer; Warning Indicators; EEC; Carburetor Circuits; Tachometer; Choke Heater; Diesel Glow Plug Control; Diesel Indicators; Electric Fuel Pump Control (7.5L);

### Power Distribution

The Alternator and Battery are connected together at the Starter Relay hot terminal. Other circuits originate at the Starter Relay hot terminal and are protected by fuse links. Low power circuits are also protected by fuses.

The Ignition Switch and Main Light Switch are powered at all times as are Fuses 1, 4, 8, 12, and 16. The other fuses are powered through the Ignition Switch or the Main Light Switch.

**100% SATISFACTION GUARANTEED**

**BUY IT NOW!**

**Click Here To Order**

# 14 CHARGE/POWER DISTRIBUTION (GASOLINE ENGINES)

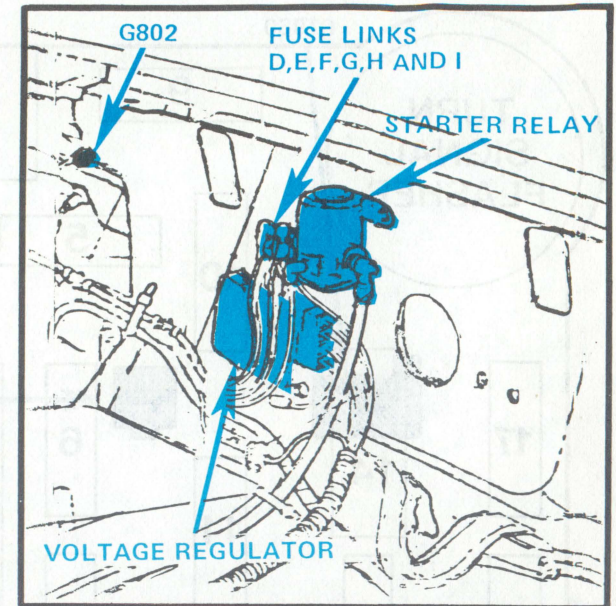
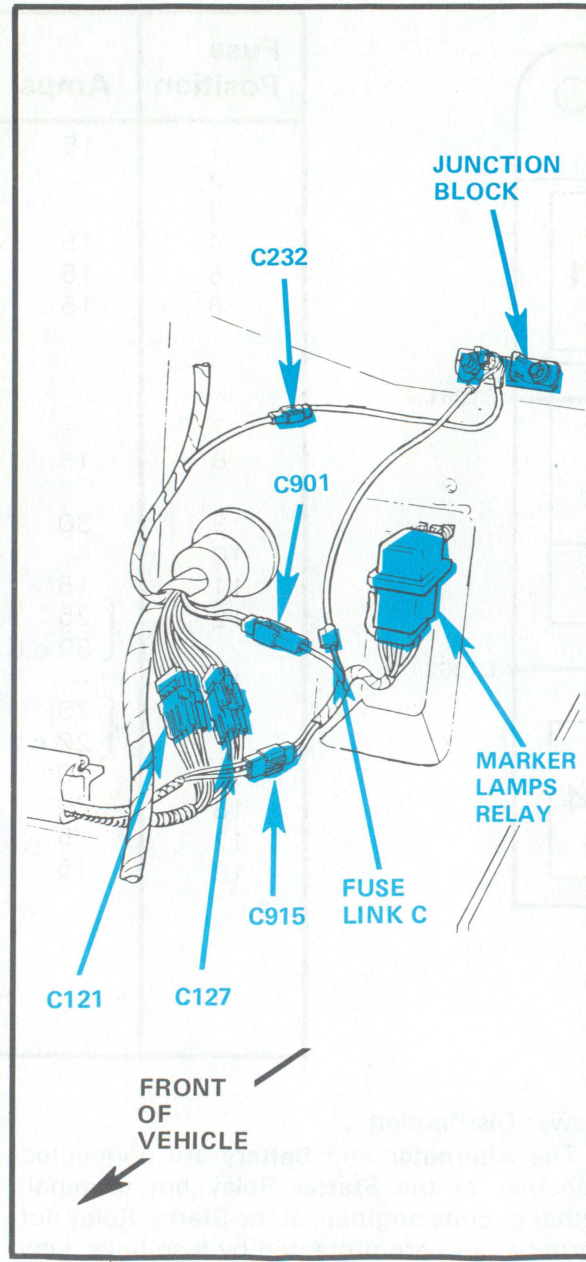
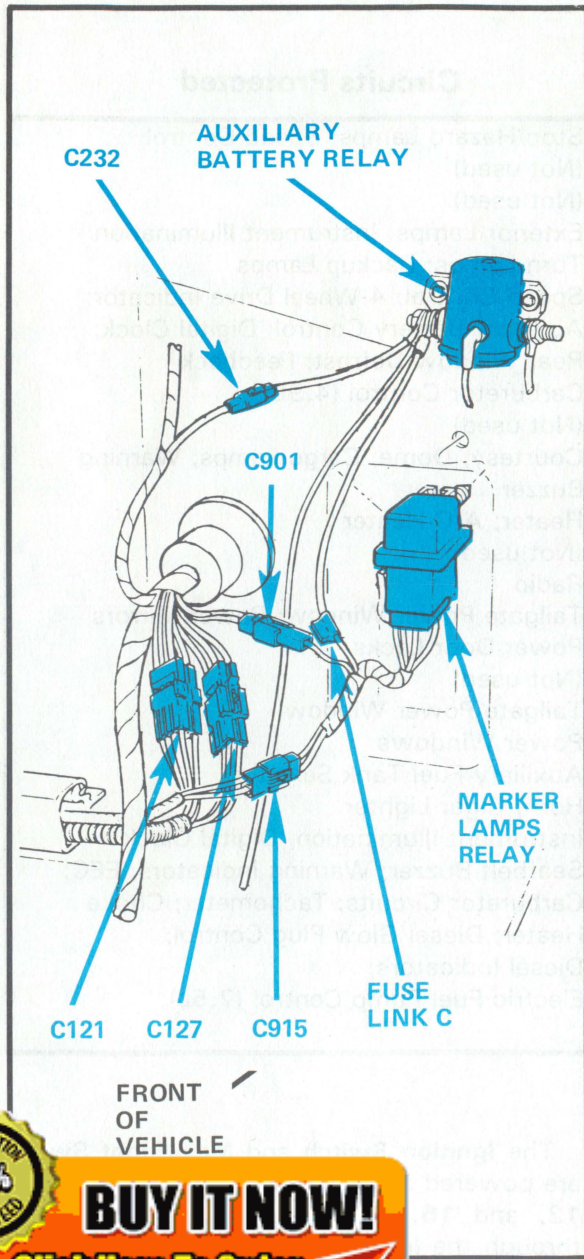

Figure 2 - LH Dash Panel For Dual Rear Wheels Without Dual Batteries

Figure 3 - RH Front Fender Apron

Figure 4 - Behind LH I/P, Rear Of Fuse Panel

**100% SATISFACTION GUARANTEED**

**BUY IT NOW!**

[Click Here To Order](#)

ADDITIONAL PAYMENT METHODS

PayPal | American Express | Discover | MasterCard | VISA

F150-F350

## GASOLINE ENGINES

WITH ALTERNATOR WARNING INDICATOR

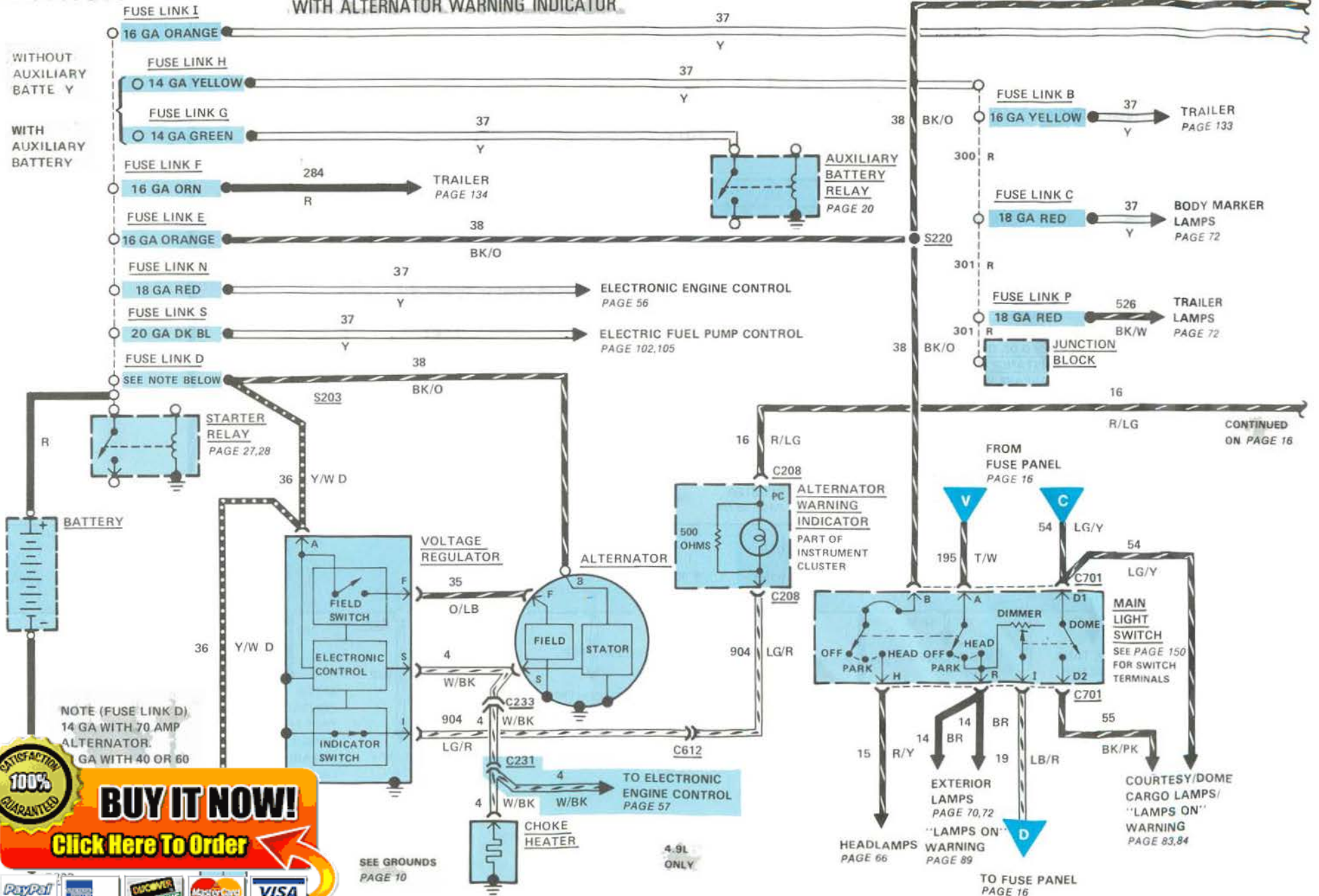

**BUY IT NOW!**

**Click Here To Order**





# CHARGE/POWER DISTRIBUTION (WITH AMMETER) GASOLINE 17

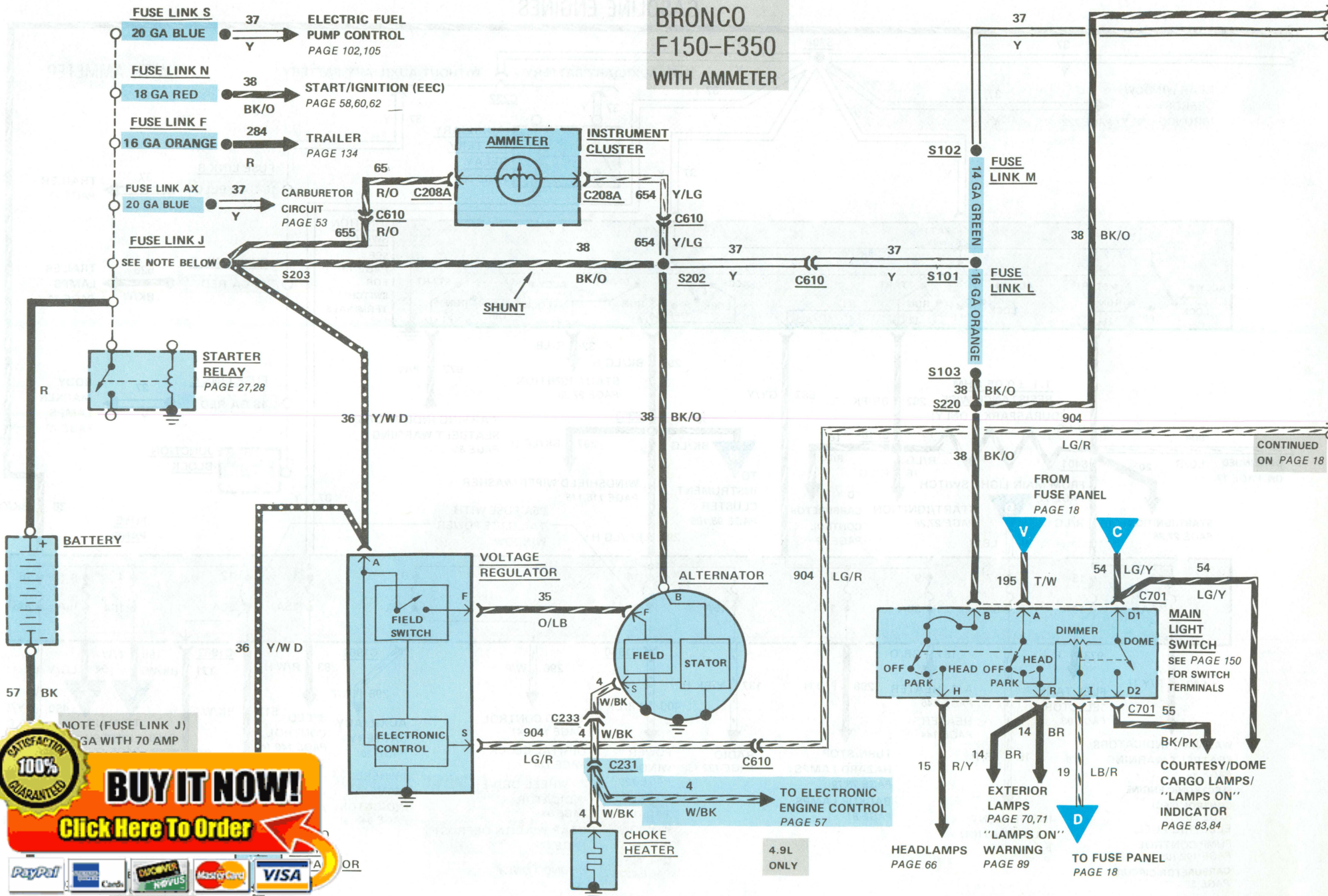

**100% SATISFACTION GUARANTEED**

**BUY IT NOW!**

**Click Here To Order**

PayPal | American Express | Discover | MasterCard | VISA



## HOW THE CIRCUIT WORKS

When an **Auxiliary Battery** is used, it is connected in parallel with the main **Battery** through **Fuse Links G** or **M**. When the **Ignition Switch** is in OFF, the **Auxiliary Battery Relay** is de-energized, and **Camper** and **Trailer** circuits are powered only from the **Auxiliary Battery**. This prevents discharging the main **Battery** when only the **Camper** or **Trailer** is being used.

The **Battery**, **Alternator** and **Voltage Regulator** make up the **Charging System**.

### With Alternator Warning Indicator

With the **Ignition Switch** in RUN, **Battery** current flows through the **Alternator Warning Indicator** into the regulator at terminal I and to ground through the solid-state indicator switch. The electronic control measures a low voltage at regulator terminal A and closes the field switch. This applies battery voltage to the field through **Alternator** terminal F.

With current in the field and the rotor turning, the **Alternator** stator produces a DC voltage at terminal B (to **Battery**) and terminal S. (Voltage at S is one-half voltage at B.)

A pre-set voltage at terminal S operates the electronic control to open the indicator switch which removes ground from the **Alternator Warning Indicator**.

The **Alternator** output is controlled by the current in the field. The average voltage on the field depends on the percentage of time the field switch is closed. The electronic control closes the field switch when the voltage at A is low and opens the switch when the voltage at

## COMPONENT LOCATION

		Page-Figure	Color	Terminals
Auxiliary Battery . . . . .	LH front fender well, behind headlamps . . . . .	22-1		
Auxiliary Battery Relay . . . . .	On LH side of dash panel . . . . .	21-2		
Choke Heater . . . . .	Attached to carburetor . . . . .	45-1		
Fuse Links B, P . . . . .	At junction block or marker lights relay . . . . .	134-1		
Fuse Link C . . . . .	At junction block or auxiliary battery relay . . . . .	14-1		
Fuse Links D, E, F, G, H, I . . . . .	At starter relay . . . . .	14-3		
Fuse Links J, L, M, N, S . . . . .	Near RH fender apron and dash panel . . . . .	21-1, 22-1		
Junction Block . . . . .	Mounted on LH dash panel . . . . .	21-5		
Radio Noise Capacitor . . . . .	Attached to voltage regulator . . . . .	36-2		
Starter Relay . . . . .	On RH fender apron . . . . .	21-1, 22-1		
Voltage Regulator . . . . .	Mounted on RH fender apron . . . . .	21-1, 22-1		
Connector C208 . . . . .	Attached to instrument cluster . . . . .	67-1	GY	14
Connector C208A . . . . .	Attached to instrument cluster . . . . .	67-1, 68-1, 69-1	GY	18
Connector C231 . . . . .	Front right of engine . . . . .	14-1, 45-1	BK	1
Connector C232 . . . . .	LH dash panel, near junction block . . . . .	21-2, 5	BL	1
Connector C233 . . . . .	At alternator . . . . .	42-1	GY	1
Connector C610 . . . . .	Below voltage regulator . . . . .	21-1, 22-2	BR	4
Connector C612 . . . . .	Below voltage regulator . . . . .	21-1, 22-2	BR	1
Connector C701 . . . . .	Attached to main light switch . . . . .	67-1, 68-1, 69-1	BK	8
Connector C1960 . . . . .	On fuse panel . . . . .	14-4	W	1
Connector C1961 . . . . .	On fuse panel . . . . .	14-4	GR	1
Connector C1962 . . . . .	On fuse panel . . . . .	14-4	BL	1
Ground G203 . . . . .	On RH side of engine . . . . .	21-3		
Ground G1201 . . . . .	On LH front fender, near battery . . . . .	22-2		

### With Ammeter

With the **Ignition Switch** in RUN, **Battery** current flows through the solid-state electronic control of the **Voltage Regulator**. The electronic control operates the solid-state field switch which applies **Battery** voltage to the **Alternator** field through terminal F.

With current in the field and the rotor turning, the **Alternator** stator produces a DC voltage at terminal B (to **Battery**). If the

**Alternator** output voltage is greater than the **Battery** terminal voltage, current will flow from the **Alternator** to the **Battery**, as well as to the vehicle electrical load. Current flowing to the battery will show as a charging current on the **Ammeter** (deflection toward 'charge'). If the battery is charged, the ammeter deflection will be small unless power windows or door locks are activated. Operation of these

**100% SATISFACTION GUARANTEED**

**BUY IT NOW!**

**Click Here To Order**

PayPal American Express Discover MasterCard VISA

# 20 CHARGE/POWER DISTRIBUTION/AUXILIARY BATTERY

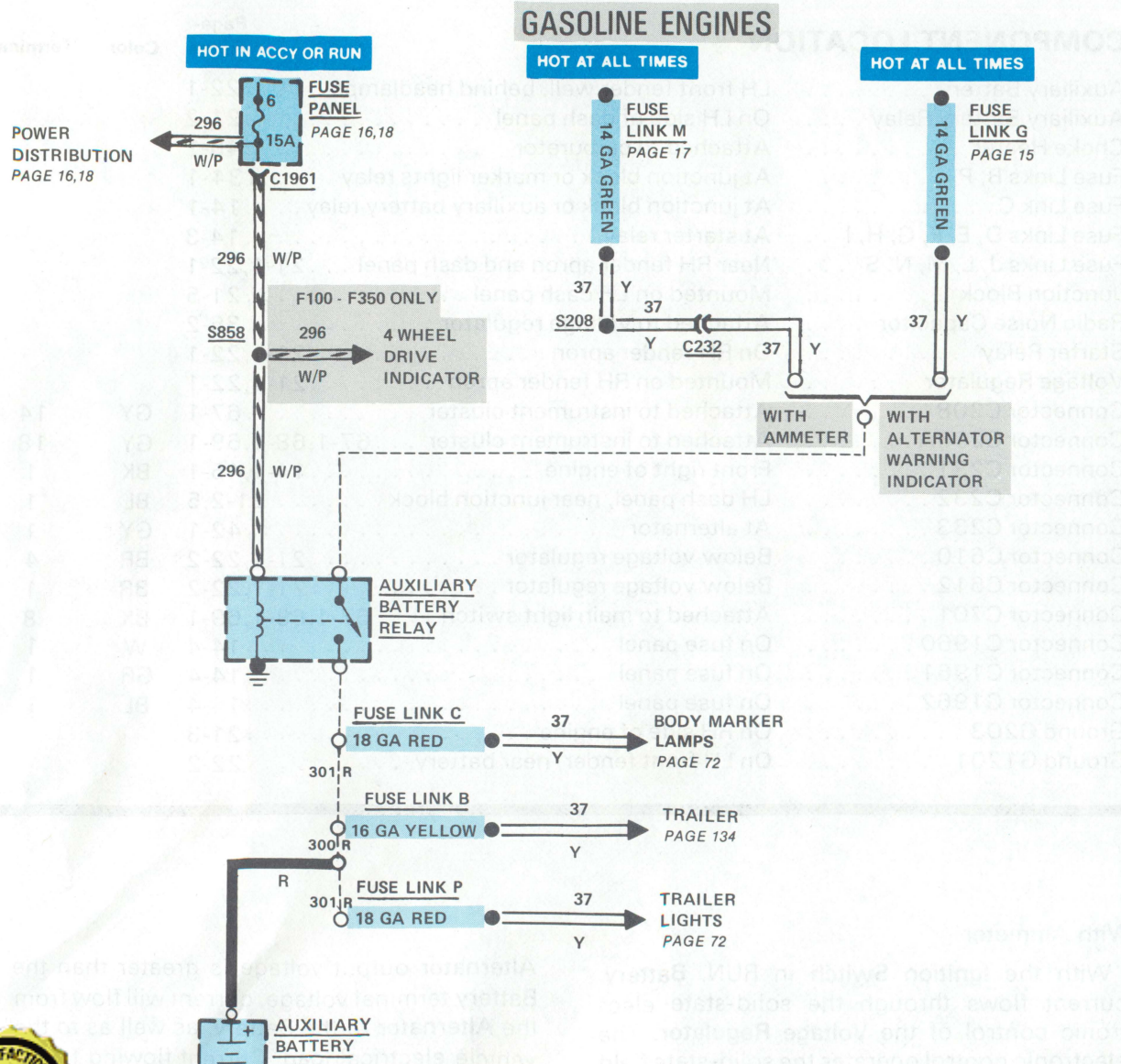

intermittent devices will give a charge indication on the **Ammeter**.

If the **Alternator** voltage is less than the **Battery** terminal voltage, current will flow *from* the **Battery** to supplement the alternator output in supplying the vehicle electrical load. This current flow will register as a 'discharge' on the **Ammeter**. The **Choke Heater** operates only when the **Alternator** is generating current (through terminal S). Above 60°F, the heater causes a thermostatic spring to pull the choke plates open within 1 to 1.5 minutes. Below 60°F, the heater does not operate and normal choke action occurs.

## NOTE

The Voltage Regulator with **BLACK** printing on the cover is used with Alternator Warning Indicator;  
**BLUE** printing with Ammeter;  
**RED** printing with either.

## TROUBLESHOOTING HINTS

The most common charge system complaints are dead **Battery** and **Ammeter** discharging (or **Alternator Warning Indicator** on at normal speed).

- Check **Fuse Link J** (Ammeter) or **Fuse Link D** (Indicator) at **Starter Relay**.
- Check **Alternator** belt tension.
- Check **Battery** terminals and cable clamps.
- Check for clean and tight connections on **Alternator, Regulator, and Starter Relay**.
- Read "Charging System Diagnosis" in the Shop Manual.

**100% SATISFACTION GUARANTEED**

**BUY IT NOW!**

**Click Here To Order**

PayPal, American Express, Discover, MasterCard, VISA

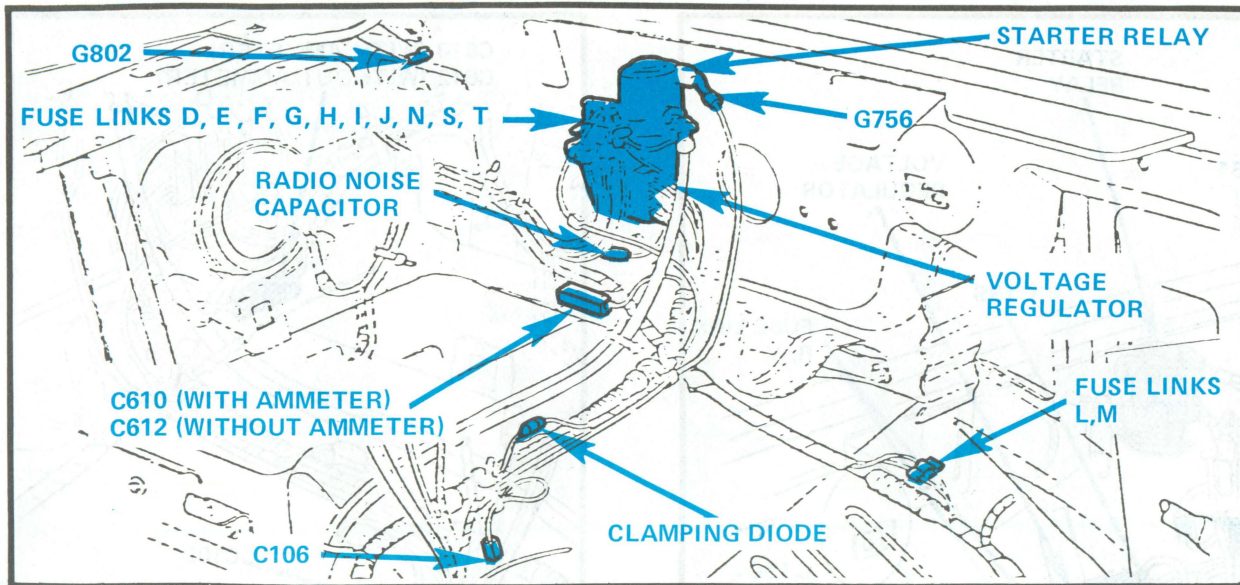

Figure 1 - RH Front Fender Apron (With EEC)

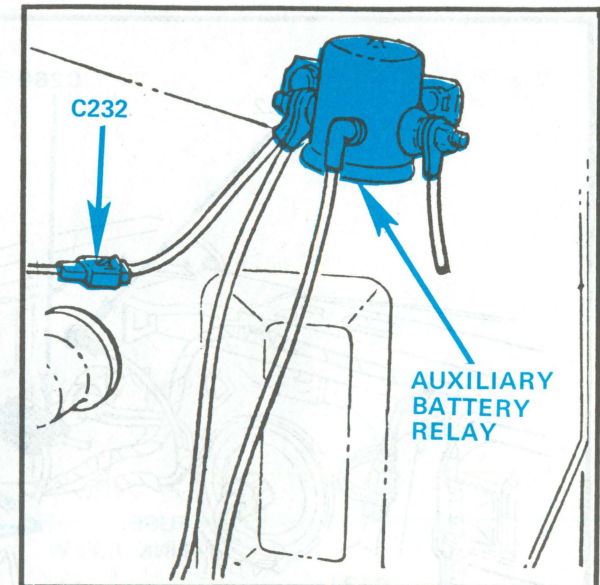

Figure 2 - LH At Side Of Dash Panel



**100% SATISFACTORY GUARANTEED**

**BUY IT NOW!**

**Click Here To Order**

PayPal, American Express, Discover, MasterCard, VISA

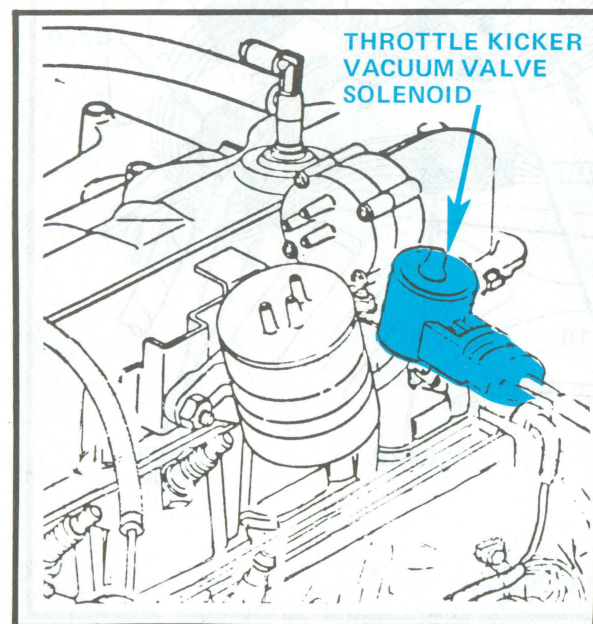

Figure 4 - LH Rear Of 4.9L Engine (Duraspark II)

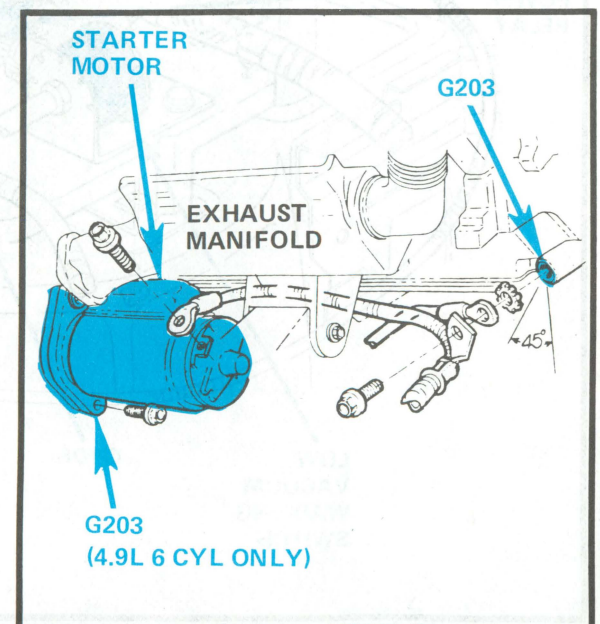

Figure 5 - LH Side Of Dash Panel

Figure 3 - Lower RH Side Of Engine



**WE SUPPORT VOLUNTARY  
TECHNICIAN CERTIFICATION**



**Ford Parts and Service Division  
Training and Publications Department**

**100% SATISFACTION GUARANTEED**

**BUY IT NOW!**

**Click Here To Order** 

0335-521-85