

# 1984 MUSTANG/ CAPRI



## DEMO

This DEMO contains only a few pages of the entire manual/product.

Not all Bookmarks work on the Demo, but they do on the full version.

### Features:

- Searchable text
- Printable pages
- Bookmarked for easy navigation
- High Resolution images
- Zoom to see exact details
- Money back Guarantee
- Available on USB and eBook download

**100% SATISFACTION GUARANTEED**

**BUY IT NOW!**

**Click Here To Order**



## Electrical & Vacuum Trouble~ Shooting Manual



License #84356800

Copyright © 2023, Forel Publishing Company, LLC, Woodbridge, Virginia

All Rights Reserved. No part of this book may be used or reproduced in any manner whatsoever without written permission of Forel Publishing Company, LLC. For information write to Forel Publishing Company, LLC, Woodbridge, VA 22192

**1984 Mustang / Capri Electrical & Vacuum Trouble-  
Shooting Manual (EVTM)  
EAN: 978-1-60371-395-5  
ISBN: 1-60371-395-6**

Forel Publishing Company, LLC  
Woodbridge, VA 22192  
Email: [sales@ForelPublishing.com](mailto:sales@ForelPublishing.com)  
<https://www.ForelPublishing.com>



This publication contains material that is reproduced and distributed under a license from Ford Motor Company. No further reproduction or distribution of the Ford Motor Company material is allowed without the express written permission of Ford Motor Company.

---

## Note from the Publisher

This product was created from the original Ford Motor Company's publication. Every effort has been made to use the original scanned images, however, due to the condition of the material; some pages have been modified to remove imperfections.

---

## Disclaimer

Although every effort was made to ensure the accuracy of this book, no representations or warranties of any kind are made concerning the accuracy, completeness or suitability of the information, either expressed or implied. As a result, the information contained within this book should be used as general information only. The author and Forel Publishing Company, LLC shall have neither liability nor responsibility to any person or entity with respect to any loss or damage caused, or alleged to be caused, directly or indirectly by the information contained in this book. Further, the publisher and author are not engaged in rendering legal or other professional services. If legal, mechanical, electrical, or other expert assistance is required, the professional should be sought.





The purpose of this manual is to show electrical and vacuum circuits of these vehicles in a clear and simple fashion to make troubleshooting easier. With each circuit is a description of *How the Circuit Works* and some *Troubleshooting Hints*. A *Component Location* chart lists components, connectors, and references to pictures in the manual.

**Wiring Diagrams** give a schematic picture of when and how the circuit is powered, what the current path is to circuit components, and how the circuit is grounded. Each circuit component is named (underlined titles). Wire and connector colors are listed (standard Ford color abbreviations are used):

## COLOR ABBREVIATIONS

<b>BL</b>	<b>Blue</b>	<b>N</b>	<b>Natural</b>
<b>BK</b>	<b>Black</b>	<b>O</b>	<b>Orange</b>
<b>BR</b>	<b>Brown</b>	<b>PK</b>	<b>Pink</b>
<b>DB</b>	<b>Dark Blue</b>	<b>P</b>	<b>Purple</b>
<b>DG</b>	<b>Dark Green</b>	<b>R</b>	<b>Red</b>
<b>GR</b>	<b>Green</b>	<b>T</b>	<b>Tan</b>
<b>GY</b>	<b>Gray</b>	<b>W</b>	<b>White</b>
<b>LB</b>	<b>Light Blue</b>	<b>Y</b>	<b>Yellow</b>
<b>LG</b>	<b>Light Green</b>		

Where two colors are shown for a wire, the first color is the basic color of the wire. The second color is the dot, hash, or stripe marking. If **D** or **H** is given, the second color is dots or hash marks. If there is no letter after the second color, the wire has a stripe.

**Connector end views** of switches and other components are shown to help with bench testing. The views show the harness wire colors that connect to the mating terminals. Connector colors and locations are shown in the *Component Location* chart. Two-color listings indicate separate colors for each connector half.

**Components** which work together are shown together. For example, all electrical components used in any circuit are shown on one diagram. The circuit breaker or fuse is shown at the top of the page. All wires, connectors, splices, switches, and motors are shown in the flow of current to ground at the bottom of the page. Notes are included which describe how switches and other components work. If a component is used in several different circuits, it is shown in several places. For example, the **Light Switch** is an electrical part of many circuits and is repeated on many pages. In some cases, however, a component may seem by its name to belong on a page where it has no electrical connection. For example, **Radio Illumination** is electrically part of **Instrument Illumination**. Since it has no electrical connection at all with the actual **Radio** circuit, it is not shown on the **Radio** page.

*Troubleshooting Hints* point the technician in a general direction, but are not intended as a step-by-step procedure. Ignition troubleshooting is an exception to this. It includes a step-by-step procedure of basic quick checks to locate some of the more common **Ignition System** problems. Read the Shop Manual for more detailed repair procedures.

The **Grounds** pages show detailed views of multiple component ground points. This is useful for checking interconnections among the ground circuits of different diagrams.

**Notes, Cautions, and Warnings** appear in boxes on text pages and contain important car and mechanic safety information.

Notes give added information to help complete a particular procedure. Cautions are included to prevent making an error that could damage the vehicle. Warnings highlight areas where carelessness can cause personal injury. The following list contains some general **Warnings** that should be followed when working on a vehicle.

- Always wear safety glasses for eye protection.
- Use safety stands whenever a procedure requires being under a vehicle.
- Be sure that the **Ignition Switch** is always in the OFF position, unless otherwise required by the procedure.
- Set the parking brake when working on any vehicle. An automatic transmission should be in PARK. A manual transmission should be in NEUTRAL.
- Operate the engine only in a well-ventilated area to avoid the danger of carbon monoxide.
- Keep away from moving parts when the engine is running, especially the fan and belts.
- To prevent serious burns, avoid contact with hot metal parts such as the radiator, exhaust manifold, tail pipe, catalytic converter, and muffler.
- Do not allow flame or sparks near the battery. Gases are always present in and around the battery cell. An explosion could occur.
- Do not smoke.
- To avoid injury, always remove rings, watches, loose hanging jewelry, and loose clothing.

Example: \_\_\_\_\_ stripe.  
 \_\_\_\_\_ hash marks.

100% SATISFACTION GUARANTEED

**BUY IT NOW!**

Click Here To Order

PayPal American Express Discover MasterCard VISA

# 2 HOW TO FIND THE ELECTRICAL PROBLEM

## TROUBLESHOOTING STEPS

These six steps present an orderly method of troubleshooting:

### Step 1. Verify the problem.

- Operate the complete system and see all symptoms for yourself in order to:
  - check the accuracy and completeness of the customer's complaint.
  - learn more that might give a clue to the nature and location of the problem.

### Step 2. Narrow the problem.

- Using the EVT, narrow down the possible causes and locations of the problem in order to more quickly find the exact cause.
- Read the description of *How the Circuit Works* and study the wiring diagram. You should then know enough about the circuit operation to figure out where to check for this trouble.

### Step 3. Test the cause.

- Use electrical test procedures to find the specific cause of the symptoms.
- *Troubleshooting Hints* will give some helpful ideas.
- The *Component Location* charts and the pictures will help you find components, grounds, and connectors.

### Step 4. Verify the cause.

- Confirm the fact that you have found the correct cause through operating the parts of the circuit you think are good.

### Step 5. Make the repair.

- Repair or replace the faulty component.

### Step 6. Verify the repair.

- Operate the system as in Step 1 and check symptoms, and see if any new

details. You will find the circuits in this manual to be helpful with these special tests.

## TROUBLESHOOTING TOOLS

### JUMPER WIRE

This is a test lead used to connect two points of a circuit. A **Jumper Wire** can complete a circuit by bypassing an open.

**Uses:** Bypassing Switches or Open Circuits

### WARNING

*Never use a jumper wire across high resistance loads (motors, etc.) connected between hot and ground. This direct battery short may cause injury or fire.*

### VOLTMETER

A DC **Voltmeter** measures circuit voltage. Connect negative (- or black) lead to ground, and positive (+ or red) lead to voltage measuring point.

### OHMMETER

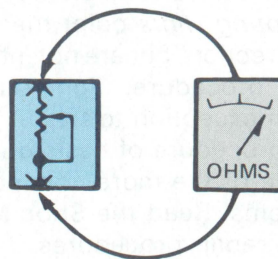

Figure 1— Resistance Check

An **Ohmmeter** shows the resistance between two connected points (Figure 1).

### TEST LIGHT

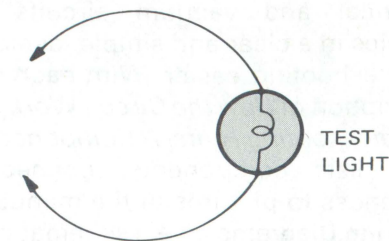

Figure 2— Test Light

A **Test Light** is a 12-volt bulb with two test leads (Figure 2).

**Uses:** Voltage Check. Short Check

### SELF-POWERED TEST LIGHT

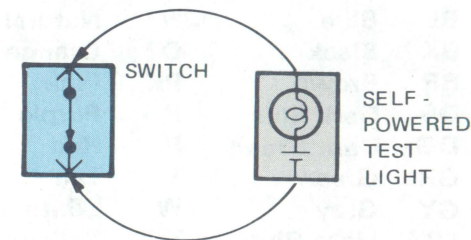

Figure 3— Continuity Check

The **Self-Powered Test Light** is a bulb, battery and set of test leads wired in series (Figure 3). When connected to two points of a continuous circuit, the bulb glows.

**Uses:** Continuity Check. Ground Check

### CAUTION

*When using a self-powered test light or ohmmeter, be sure power is off in circuit during testing. Hot circuits can cause equipment damage and false readings.*

**SATISFACTION 100% GUARANTEED**

**BUY IT NOW!**

**Click Here To Order**

PayPal   American Express   Discover   MasterCard   VISA

special test  
See the  
looks for

## TROUBLESHOOTING CHECKS

### SWITCH CIRCUIT CHECK

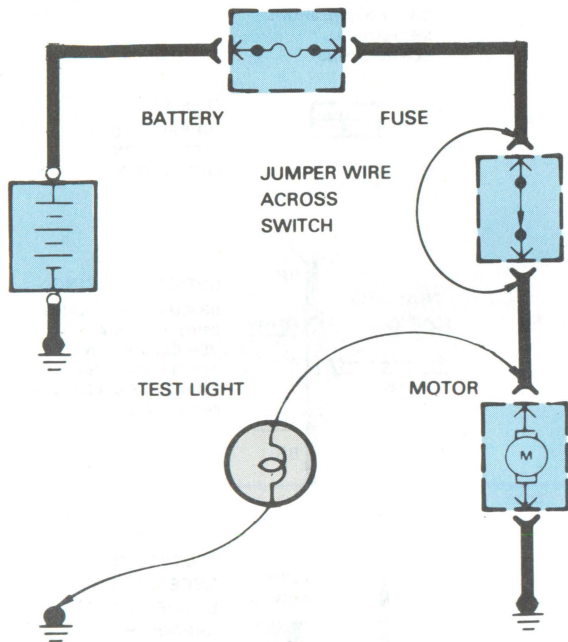

Figure 4—Switch Circuit Check and Voltage Check

In a bad circuit with a switch in series with the load, jumper the terminals of the switch to power the load. If jumping the terminals powers the circuit, the switch is bad (Figure 4).

### CONTINUITY CHECK (Locating open circuits)

Connect one lead of **Self-Powered Test Light** or **Ohmmeter** to each end of circuit (Figure 3). Light will glow if circuit is closed. Switches and fuses can be checked in the same way.

### SHORT CHECK

Connect one lead of **Self-Powered Test Light** or **Ohmmeter** to a known battery or power source. Connect the other lead to the suspected short. The light will glow when the circuit is closed.

### SHORT CHECK (short to ground)

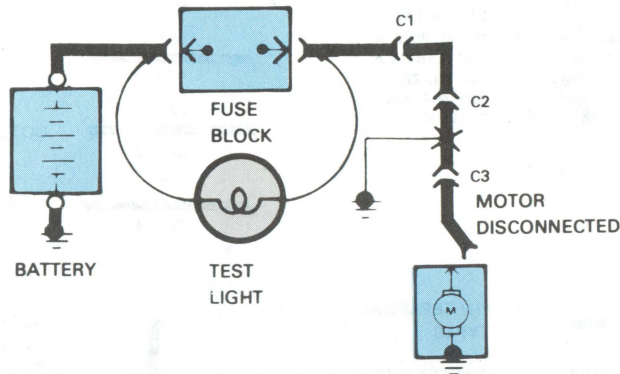

Figure 5— Short Check

A fuse that repeatedly blows is usually caused by a short to ground. It's important to be able to locate such a short quickly (Figure 5).

- 1) Turn off everything powered through the fuse.
- 2) Disconnect other loads powered through the fuse:
  - Motors: disconnect motor connector.
  - Lights: remove bulbs.
- 3) Turn **Ignition Switch** to RUN (if necessary) to power fuse.
- 4) Connect one **Test Light** lead to hot end of blown fuse. Connect other lead to ground. Bulb should glow showing power to fuse. *(This step is just a check to be sure you have power to the circuit.)*
- 5) Disconnect the **Test Light** lead from ground and reconnect it to the load side of the fuse.
  - If the **Test Light** is off, the short is in the disconnected equipment.
  - If the **Test Light** goes on, the short is in the wiring. You must find the short by disconnecting the circuit connectors one at a time until the **Test Light** goes out. For example: with a ground at X, the bulb goes out when C1 or C2 is disconnected, but stays on after disconnecting C3. This

means the ground is between C2 and C3.

### "GOOD GROUND" CHECK

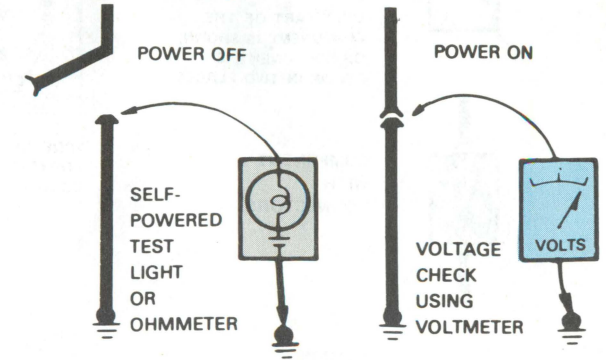

Figure 6 – Grounds Checks

Turn on power to circuit. Perform Voltage Check between suspected bad ground and frame. Any voltage means ground is bad.

Turn off power to circuit. Connect one lead of **Self-Powered Test Light** or **Ohmmeter** to wire in question, and the other to known ground. If bulb glows, circuit ground is OK (Figure 6).

## TROUBLESHOOTING HINTS

The circuit schematics in this manual are designed to make it easy to identify common points in circuits. This knowledge can help narrow the problem to a specific area. For example, if several circuits fail at the same time, check for a common power or ground connection. (See *Power Distribution* or *Grounds*). If part of a circuit fails, check the connections between the part that works and the part that doesn't work.

For example, if low beam headlights work, but high beams and the indicator light don't work, then power and ground paths must be good. Since the dimmer switch is the component which switches this power to the high beam lights and indicator, it is most likely the cause of failure.

**100% SATISFACTION GUARANTEED**

**BUY IT NOW!**

Click Here To Order

known battery  
e other  
hen the

PayPal American Express Discover Novus MasterCard VISA

# 4 ELECTRICAL SYMBOLS

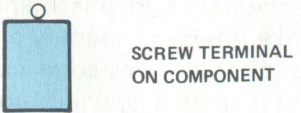
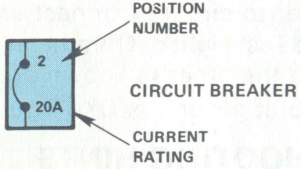
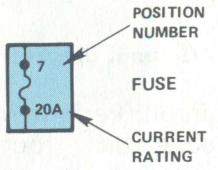
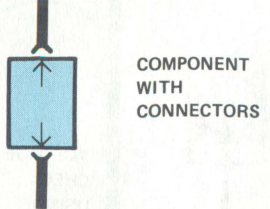
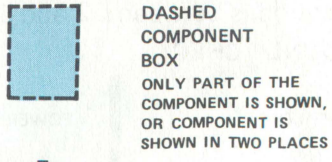

SOLID STATE

SEALED ELECTRONIC COMPONENT  
ANY CIRCUITRY SHOWN INSIDE THE BOX IS A FUNCTIONAL

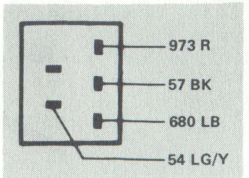

WIRE COLORS ARE LABELED FOR MATING HARNESS CONNECTOR

COMPONENT CONNECTOR END VIEW  
SHOWS PINS OR SOCKETS ON A COMPONENT TO AID IN BENCH TESTING

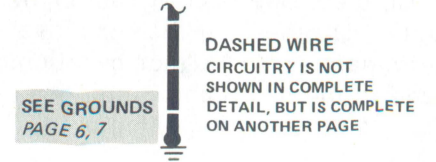
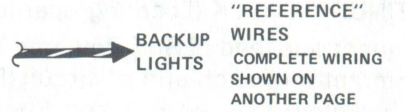
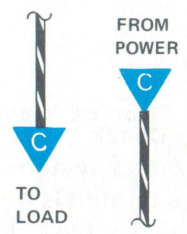
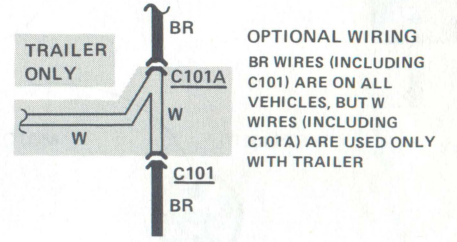
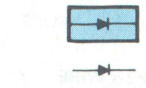
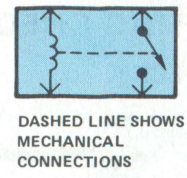
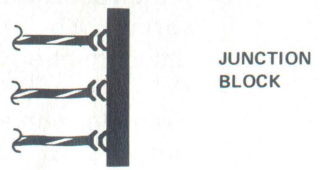
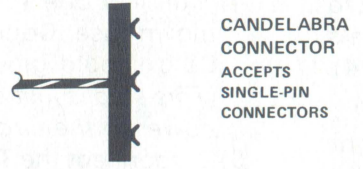
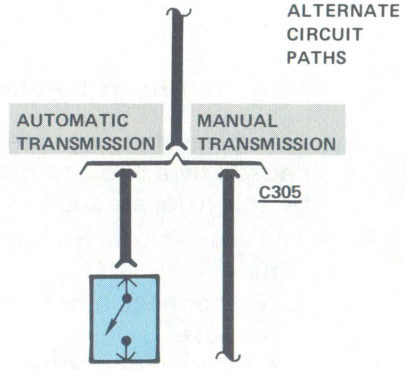
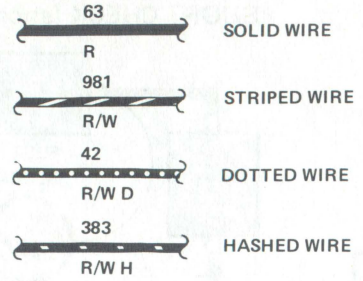
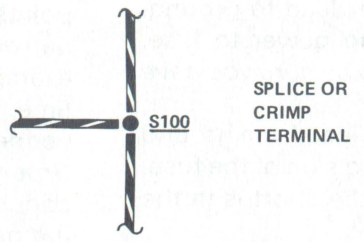
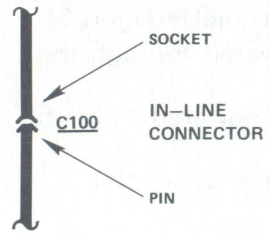

**100% SATISFACTION GUARANTEED**

**BUY IT NOW!**

Click Here To Order

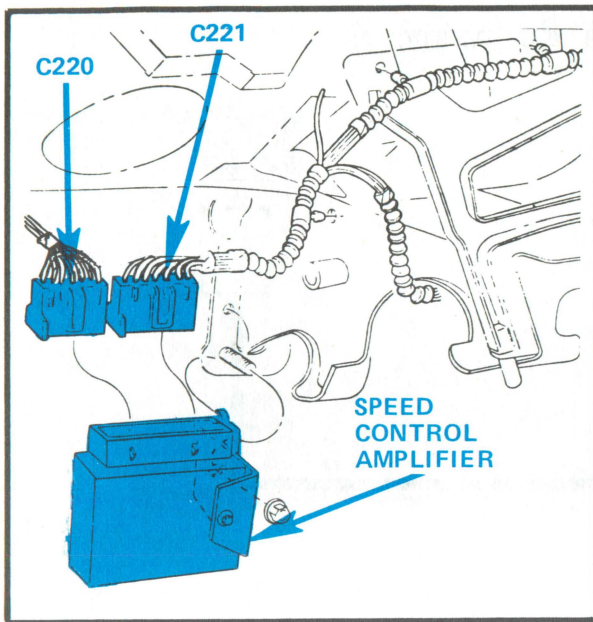

Figure 1 - LH Cowl Area

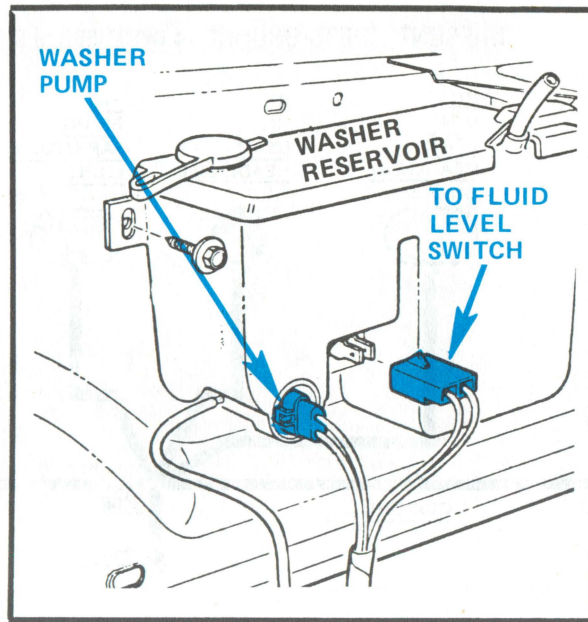

Figure 2 - LH Engine Cowl (5.0L Engine)

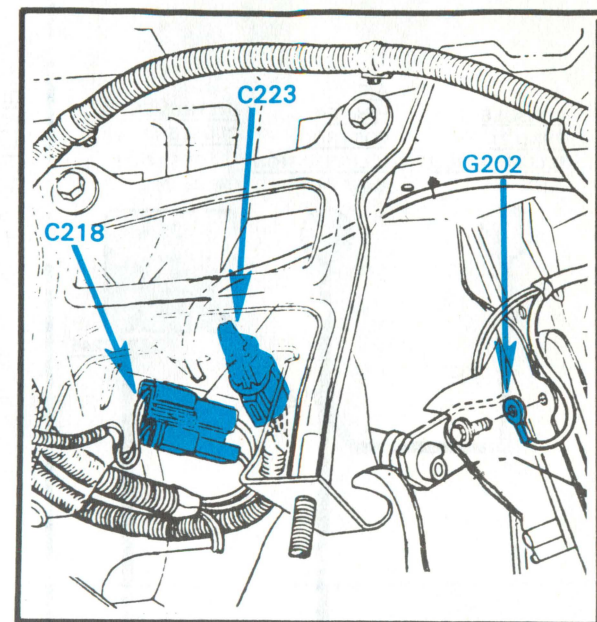

Figure 3 - Under LH Side of I/P

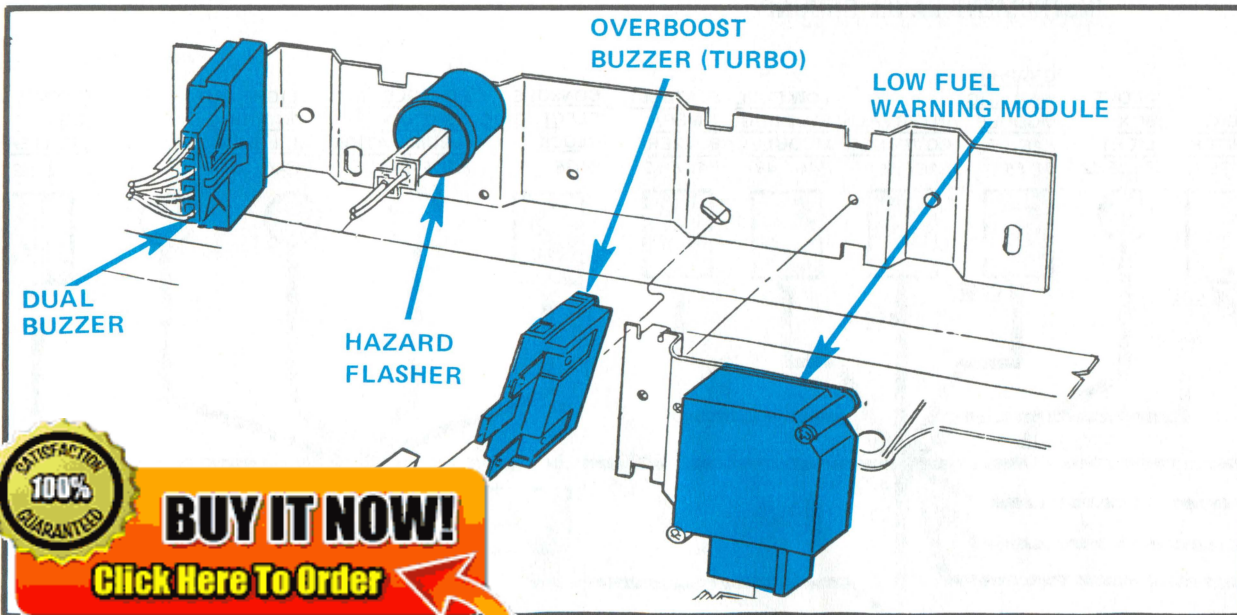

Figure 4 - Behind RH Side of I/P

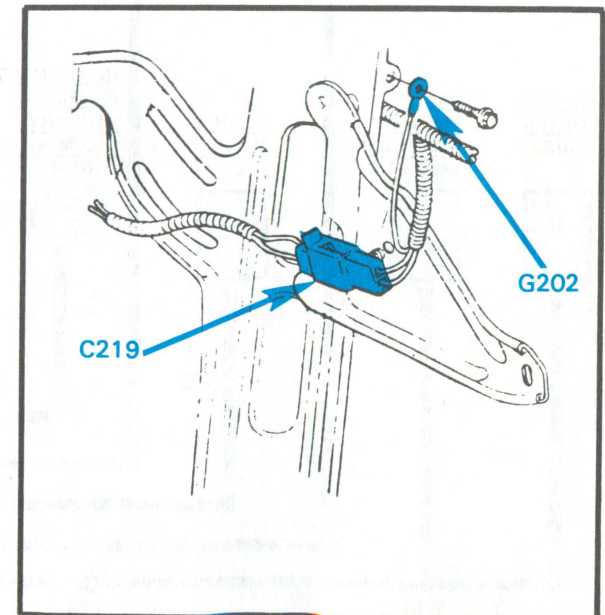
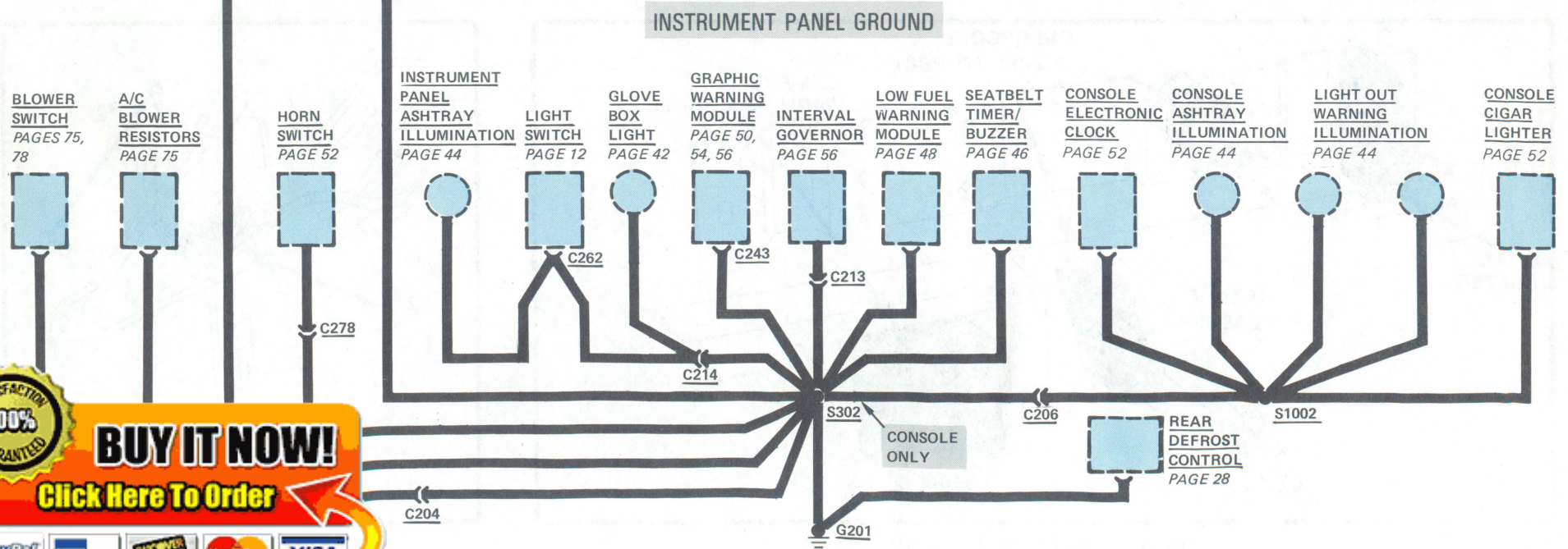
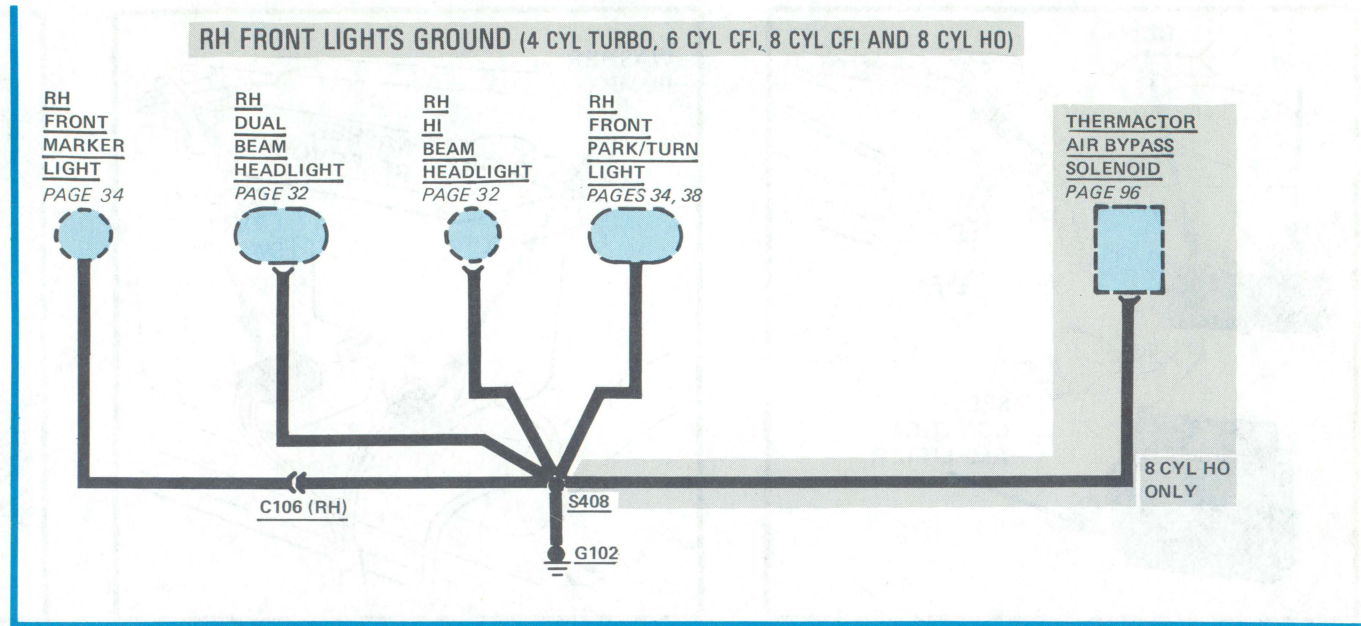

Figure 5 - Under LH Side Of I/P

**100% SATISFACTION GUARANTEED**

**BUY IT NOW!**

**Click Here To Order**



**SATISFACTION 100% GUARANTEED**  
**BUY IT NOW!**  
 Click Here To Order

The ground circuits shown here are complete, and connect several components together to screw terminal ground points. On other pages only parts of these circuits may be shown. Partial ground circuits are shown dashed on those pages.

All simple or component ground circuits are shown on the individual circuit pages, and are complete on those pages.

All wires are **57 BK** unless otherwise noted.

## COMPONENT LOCATION

		Page-Figure	Color	Terminals
Connector C106	Near both RH and LH side markers	33-1	BR	2
Connector C152	LH fender apron		BL	1
Connector C204	Behind RH side of I/P above glove box	78-1	GY	4
Connector C206	Attached behind graphic warning module	51-1	GY	4
Connector C213	Under LH side of I/P	53-1	BK	6
Connector C214	Clipped to LH I/P support brace	45-3	GY	4
Connector C241	Behind center of I/P above radio	78-1	BR	2
Connector C243	Attached to graphic warning module	51-1	GY	8
Connector C246	Behind LH side of I/P on instrument cluster	89-1	GY	14
Connector C233	Near transmission support brace			2
Connector C312	LH side of transmission hump	47-1	GY	2
Connector C318	RH side of fuel tank			4
Connector C319	Under car at RH rear seat			2
Ground G102	Top RH side of radiator support	33-1		
Ground G103	Top LH side of radiator support	33-1		
Ground G201	Behind LH side of glove box	45-1		
Ground G301	LH side of trunk lid striker	35-2		

### NOTE

See LH FRONT LIGHTS GROUND on pages 20 and 21.

See REAR LIGHTS GROUND on pages 26 and 27.

### RH FRONT LIGHTS GROUNDS (4 CYL 50 STATES AND CANADA)

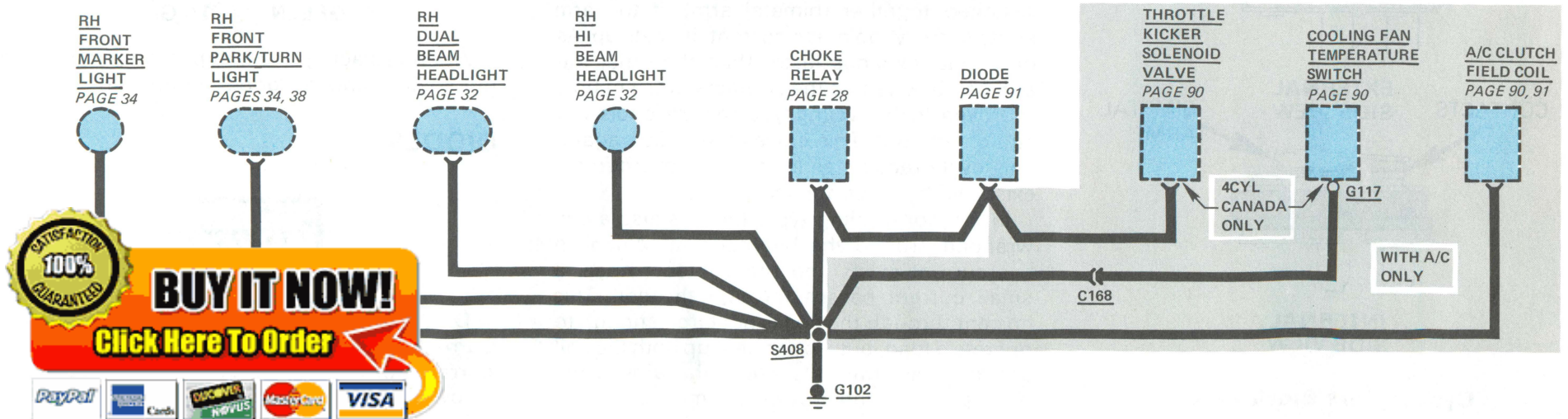

**100% SATISFACTION GUARANTEED**

**BUY IT NOW!**

**Click Here To Order**

## REPLACEMENT OF FUSES/ CIRCUIT BREAKERS



GOOD FUSE

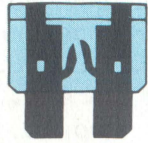

BLOWN FUSE

Fuses are mounted either in the **Fuse Block** or in-line. They are identified by the numbered value in amperes, and by a color code. Some positions may have either a fuse with adapter or a circuit breaker. Be sure to replace a fuse or circuit breaker with the same kind of unit and with the same ampere rating. Remove fuses in order to check them.

## CIRCUIT BREAKER OPERATION

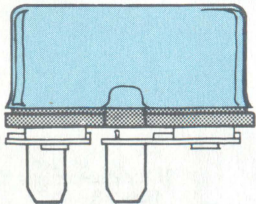

EXTERNAL  
SIDE VIEW

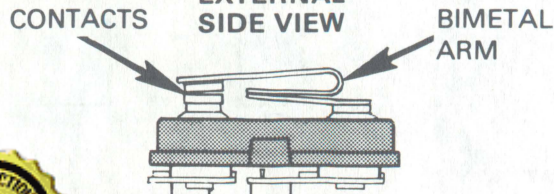

CONTACTS

BIMETAL  
ARM

**100% SATISFACTION GUARANTEED**

**BUY IT NOW!**

**Click Here To Order**

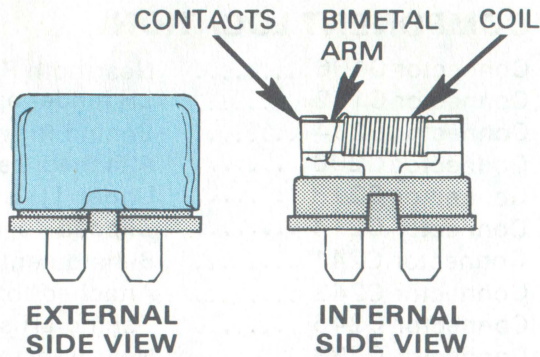

EXTERNAL  
SIDE VIEW

INTERNAL  
SIDE VIEW

### Non-Cycling Fuse Block Type

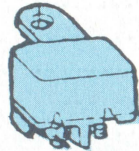

### Cycling In-Line Type

Some circuits are protected by circuit breakers. (Abbreviated "c.b." in fuse chart.) They can be **Fuse Block** mounted or in-line. Like fuses, they are rated in amperes.

Each circuit breaker conducts current through an arm made of two types of metal fastened together (bimetal arm). If the arm starts to carry too much current, it heats up. As one metal expands faster than the other the arm bends, opening the contacts. Current flow is broken. In the cycling type, the arm cools and straightens out. This closes the circuit again. This cycle repeats as long as the overcurrent exists, with power applied.

In the non-cycling type, there is also a coil wrapped around the bimetal arm. When an overcurrent exists and the contacts open, a small current passes through the coil. This current through the coil is not large enough to operate a load, but it does heat up both the coil and bimetal arm. This keeps the arm in the open position until power is removed.

## FUSE LINKS

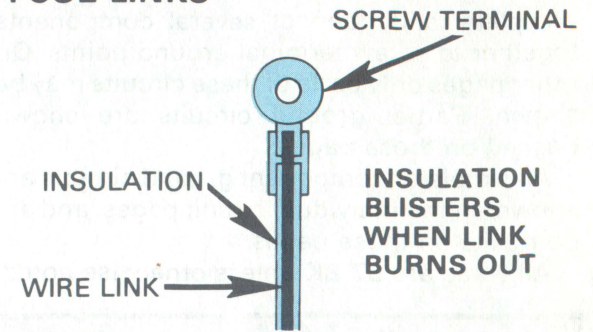

The fuse link is a short length of wire smaller in gage than the wire in the protected circuit. The wire is covered with a thick non-flammable insulation. An overload causes the link to heat and the insulation to blister. If the overload remains, the link will melt, causing an open circuit. The links are color coded for wire size as follows:

### COLOR CODE

BLUE	20 GA
BROWN	18 GA
BLACK	16 GA
GREEN	14 GA

When replacing, make tight crimp joints or hot solder joints for good connections.

## DIODES

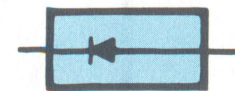

Diodes are electrical devices that permit current to flow in one direction only. The current flows in the direction indicated by the arrow.

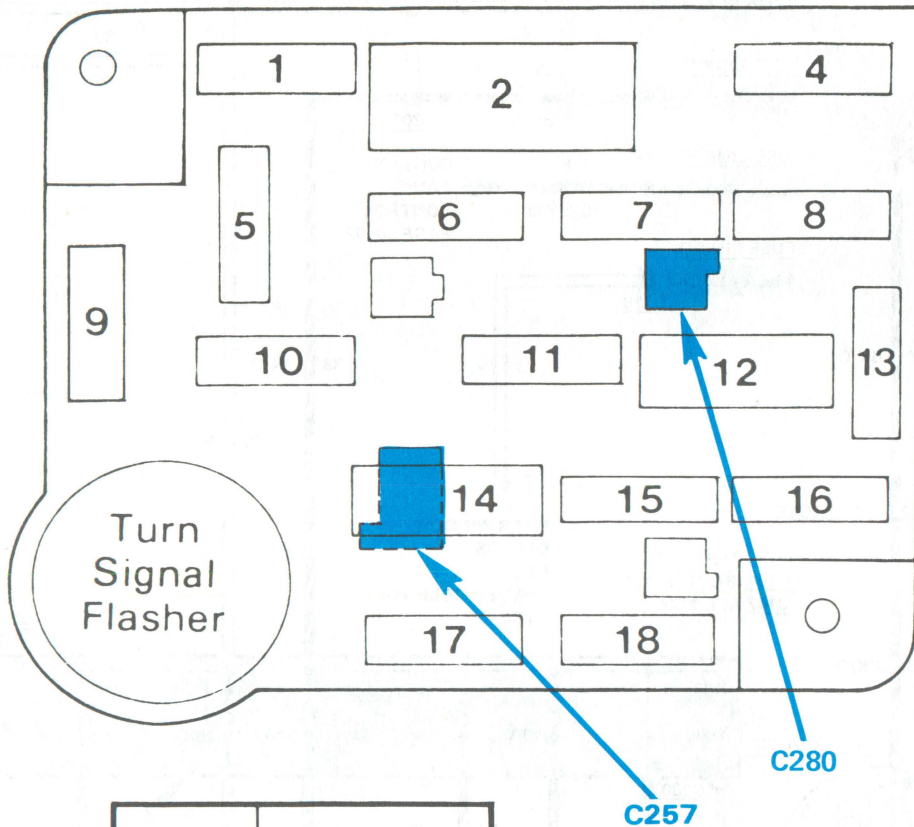

Fuse Position	Amps	Circuits Protected
1	15	Stop/Hazard Lights; Speed Control
2	6 c.b.	Windshield Wiper/Washer; Interval Wiper
4	10	Exterior Lights; Instrument Illumination
5	15	Turn Lights; Backup Lights
6	20	A/C Clutch; Speed Control; Rear Window Defrost; Trunk Release; Digital Clock; Light Out Warning.
7	—	(Not Used)
8	15	Courtesy Lights; Clock; Key Warning; Fuel Filler Door Release
9	15 or 30	Heater Blower (15 amps); A/C Blower (30 amps)
10	20	Passing Beam
11	15	Radio, Premium Sound
12	20 c.b.	Power Door Locks
13	5	Instrument Illumination
14	20c.b.	Power Windows
15	—	(Not used)
16	20	Horn; Cigar Lighter; Digital Clock
17	—	(Not Used)
18	15	Seatbelt Buzzer; Warning Indicators; Carburetor Circuits; Tachometer; Low Fuel Warning; Idle Tracking Air Control; Restart Choke Control; Cooling Fan/Compressor Clutch Control.

Fuse Value Amps	Color Code
4	Pink
5	Tan
10	Red
15	Light Blue

### Power Distribution

The **Alternator** and **Battery** are connected together at the **Starter Relay** hot terminal. Other circuits originate at the **Starter Relay** hot terminal and are protected by fuse links. Low power circuits are also protected by fuses.

The **Ignition Switch** and **Light Switch** are powered at all times, as are **Fuses 1, 4, 8, 10** and **16**. The other fuses are powered through the **Ignition Switch** or the **Light Switch**.

Position **3** is not used, and is covered by **Circuit Breaker 2**.

**100% SATISFACTION GUARANTEED**

**BUY IT NOW!**

**Click Here To Order**

# 10 CHARGE/POWER DISTRIBUTION

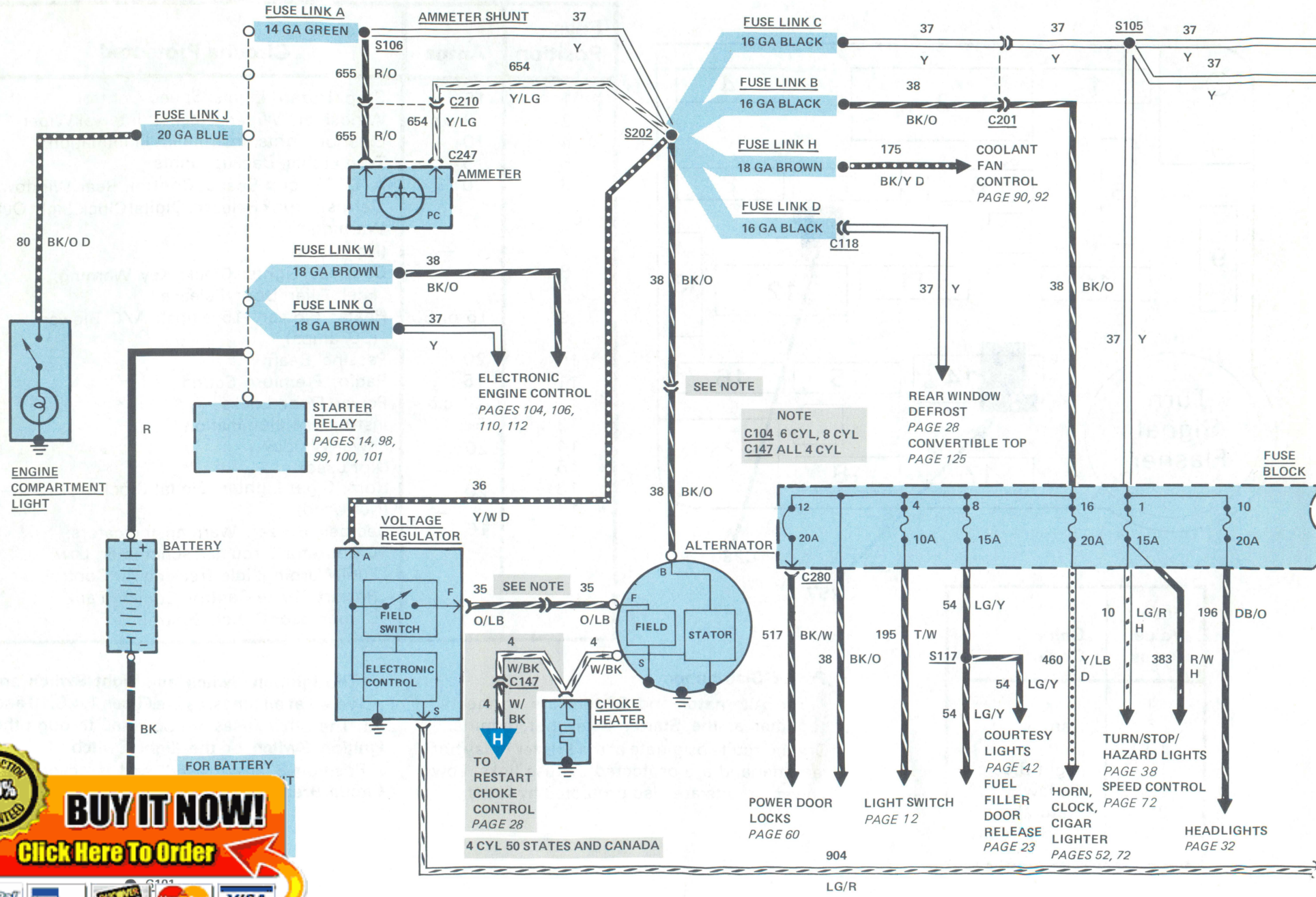

**100% SATISFACTION GUARANTEED**

**BUY IT NOW!**

**Click Here To Order**

FOR BATTERY

PayPal

Discover

MasterCard

VISA



# 12 CHARGE/POWER DISTRIBUTION (LIGHT SWITCH)

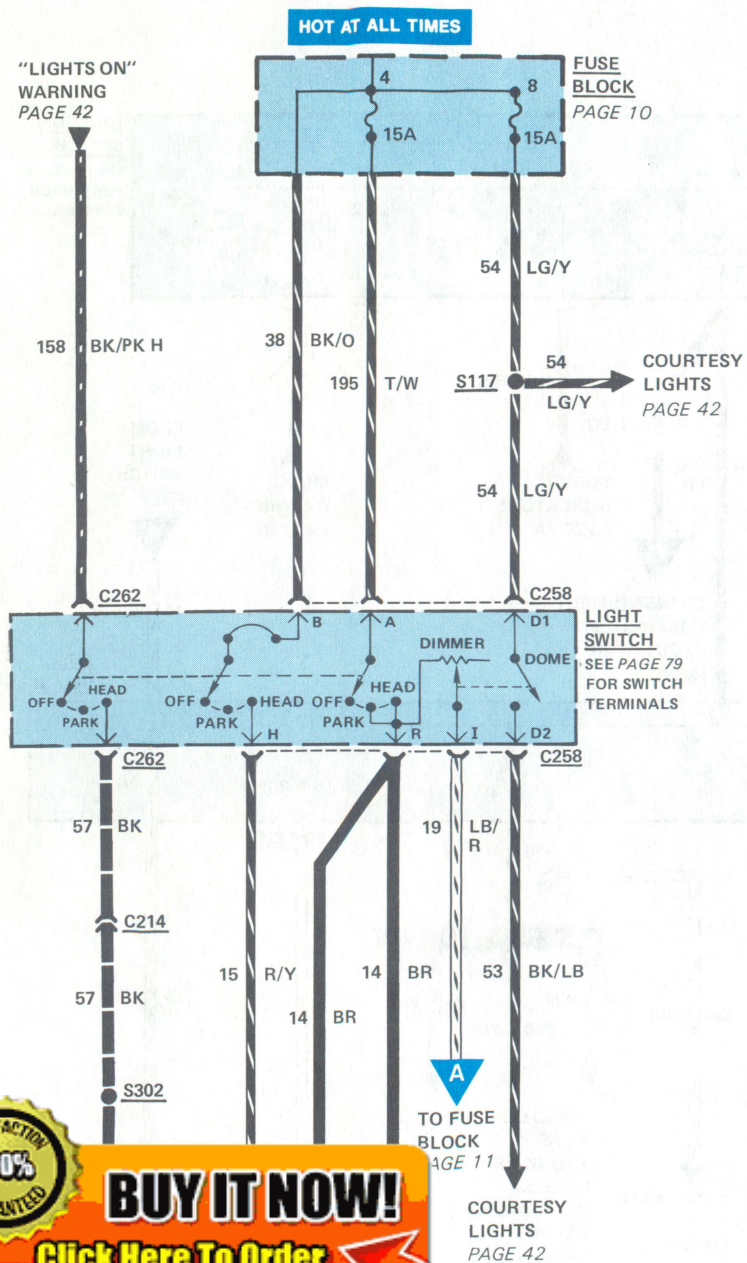

## ENGINES

The following engines are used in the 1984 Mustang/Capri:

- 4 CYL CANADA ..... (2.3L Carbureted)
- 4 CYL 50 STATES ..... (2.3L EEC-IV)
- 4 CYL TURBO ..... (2.3L EFI)
- 6 CYL CFI ..... (3.8L V6 EEC-IV)
- 8 CYL CFI ..... (5.0L V8 EEC-IV)
- 8 CYL HO ..... (5.0L V8 4V Carbureted)

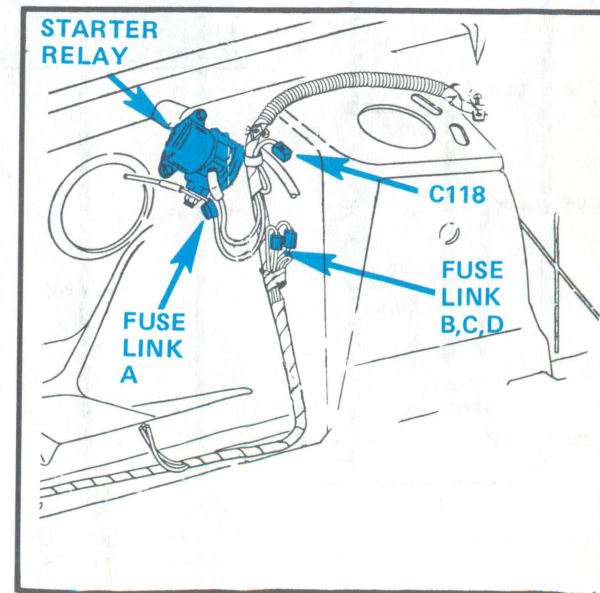

Figure 1 - RH Front Fender

**SATISFACTION 100% GUARANTEED**

**BUY IT NOW!**

**Click Here To Order**

PayPal, American Express, Discover, MasterCard, VISA

## CHARGE

### HOW THE CIRCUIT WORKS

The **Battery**, **Alternator**, and **Voltage Regulator** make up the **Charging System**.

With the **Ignition Switch** in **RUN**, **Battery** current flows through the solid-state **Electronic Control** of the **Voltage Regulator**. The **Electronic Control** operates the solid-state field switch which applies **Battery** voltage to the **Alternator** field through terminal **F**.

With current in the field and the rotor turning, the **Alternator** stator produces a DC voltage at terminal **B** (to **Battery**). This voltage balances the **Battery** voltage. If the voltages are different, the resulting current flow is indicated on the **Ammeter**. The **Choke Heater** operates only when the **Alternator** is generating current (through terminal **S**). Above 60°F, the heater causes a thermostatic spring to pull the choke plates open within 1 to 1.5 minutes. Below 60°F, the heater does not operate and normal choke action occurs.

#### NOTE

The Voltage Regulator with BLUE printing on the cover is used with Ammeter; RED printing with either Ammeter or Alternator Warning Indicator.

### COMPONENT LOCATION

		Page- Figure	Color	Terminals
Alternator (4 cyl) .....	LH front of engine assembly			
(6 and 8 cyl) ...	RH front of engine assembly			
Ammeter .....	Part of instrument cluster			
Choke Heater.....	Attached to carburetor			
Fuse Links A, B, C, D, H, W .....	Near starter relay assembly .....	12-2		
Fuse Link J .....	At starter relay.....	61-1		
Fuse Links K, L, N .....	Near LH shock tower.....	25-2		
Starter Relay .....	RH fender apron in front of wheel well (except turbo) .....	12-1		
Voltage Regulator .....	RH fender apron attached below starter relay			
Connector C104 .....	Near starter relay .....		BR	2
Connector C118 .....	LH fender apron below starter relay.....	12-1	GY	1
Connector C147 .....	Lower LH frame near shock tower .....			3
Connector C201 .....	Under LH side of I/P on shake brace.....	22-2	GY	8
Connector C208 .....	Under LH side of I/P on shake brace.....	22-2	GY	4
Connector C210 .....	Under LH side of I/P on shake brace.....	22-2	BR	6
Connector C214 .....	Clipped to LH I/P support brace.....	45-3	GY	4
Connector C217 .....	Behind LH side of I/P above fuse block .....	22-1	Y	3
Connector C247 .....	Behind LH side of I/P on instrument cluster	89-1	GY	14
Connector C258 .....	Behind LH side of I/P attached to light switch	45-2	GY	7
Ground G101 .....	Lower LH front of engine assembly .....	13-1		
Ground G201 .....	Behind LH side of glove box .....	45-1		

### TROUBLESHOOTING HINTS

#### IMPROPER CHARGING

The most common charge system complaints are dead **Battery**, and **Ammeter** discharging at normal speed.

- Check **Fuse Link A** at **Starter Relay**.
- Check **Alternator** belt tension.
- Check **Battery** terminals and cable clamps.
- Check for clean and tight connections on **Alternator**, **Regulator**, and **Starter Relay**.

Read "Charging System Diagnosis" in Section 31-01 of Shop Manual for detailed Charging System tests.

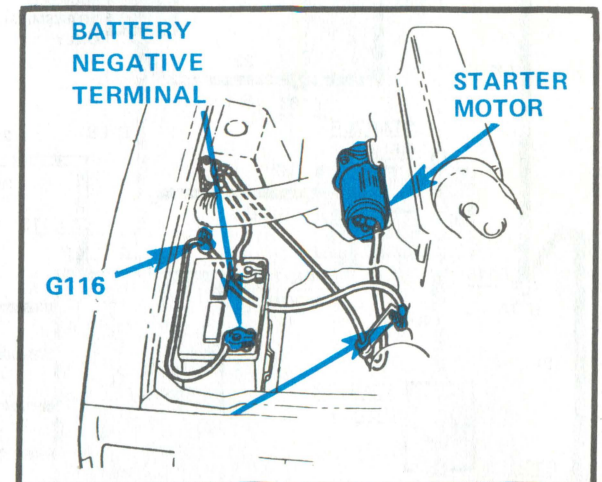

Figure 1 - RH Fender

**100% SATISFACTION GUARANTEED**

**BUY IT NOW!**

**Click Here To Order**



# START

## HOW THE CIRCUIT WORKS

The **Battery**, **Starter Motor**, **Starter Relay**, and **Ignition Switch** make up the **Starting System**. In vehicles with automatic transmission, the **Neutral Safety Switch** must be closed (PARK or NEUTRAL) in order to operate the **Starter Motor**.

Turning the **Ignition Switch** to START sends current through the **Starter Relay** coil and operates the relay. Current from the **Battery** then flows directly through the **Starter Relay** to the **Starter Motor** to start the engine.

When the **Ignition Switch** is in START, Battery voltage is applied to the START (white) wire of the **Ignition Module** through circuit 32. Full voltage is applied to the BATT terminal of the **Ignition Coil**. After the engine has started, **Ignition Coil** voltage is reduced through the **1.1 Ohm Resistance Wire**.

## TROUBLESHOOTING HINTS

### CHECK BATTERY AND CABLES

- Check condition of **Battery**. Recharge or replace if necessary. Read part 31-02 of Shop Manual.
- Check **Battery** posts and cable lugs.
- Check cable terminals at **Starter Relay**, engine ground, and **Starter Motor** and clean if necessary. Make sure cable wire strands are securely attached in terminals. Cables are tight when eyelet can't be easily turned and.

(ove).  
er Motor.

## COMPONENT LOCATION

		Page-Figure	Color	Terminals
Clutch Safety Switch.....	Above clutch pedal			
Distributor (8 cyl) .....	Top front of engine			
Fuse Link C .....	At starter relay assembly .....	12-1		
Ignition Coil (4 & 8 cyl) ..	LH fender apron .....	25-2		
(6 cyl) .....	Lower LH side of engine			
Ignition Module .....	LH fender apron .....	25-2		
Ignition Switch .....	Lower RH side of steering column .....	53-1		
Backup/Neutral Safety Switch .....	Part of transmission assembly .....	22-4		
Starter Motor.....	Lower RH rear of engine .....	13-1		
Starter Relay .....	RH fender apron in front of wheel well .....	12-1		
Connector C107 .....	Attached to LH side of transmission support	22-4	BR	4
Connector C111 .....	LH fender apron .....	25-2	BK	4
Connector C112 .....	LH fender apron .....	25-2	BK	3
Connector C113.....	Near distributor .....		BK	3
Connector C135 (8 cyl)...	Center of dash panel .....		GY	8
(4 cyl) .....	LH fender apron .....	25-2	GY	8
Connector C156.....	Center of dash panel.....		BK	4
Connector C201 .....	Under LH side of I/P on shake brace.....	22-2	GY	8
Connector C208 .....	Under LH side of I/P on shake brace.....	22-2	GY	4
Connector C210 .....	Under LH side of I/P on shake brace.....	22-2	BR	6
Connector C246 .....	Behind LH side of I/P on instrument cluster	89-1	GY	14
Ground G101 .....	Lower LH front of engine assembly.....	13-1		
Ground G116 .....	Inside RH fender behind battery.....	13-1		
Ground G201 .....	Behind LH side of glove box .....	45-1		

### IF STARTER RELAY CHATTERS OR DOESN'T CLICK (STARTER DOES NOT CRANK)

- Check **Battery** and cables (see above).
- Make sure **Starter Relay** bracket is grounded tightly.
- With **R/LB** wire removed from **Starter Relay**, and transmission in PARK or NEUTRAL, jumper this terminal on **Starter Relay** to main terminal (**Battery** connection). If **Starter Motor** works, check **Ignition Switch**. Check wiring to **Starter Relay** for open or dirty connections. If this jumper doesn't operate **Starter Relay**, replace it.

### IF STARTER DOES NOT CRANK AND STARTER RELAY CLICKS

- Clean and tighten cable connection to **Starter Motor** terminal and relay terminals. Check cable to **Starter Motor** for damage and make sure wire strands are secure in eyelets.
- If still bad, repair or replace **Starter Motor**.

### IF STARTER SPINS (HUMMING NOISE) BUT DOES NOT CRANK ENGINE

- Remove **Starter Motor**. Repair or replace starter drive.

- Read the Shop Manual for detailed Starting tests.

## TACHOMETER TROUBLESHOOTING HINTS

### TACHOMETER READS HIGH OR LOW

- Check that 3-position switch on front of tach (behind mask) is in proper position for number of cylinders in engine.

### NO TACHOMETER INDICATION

- Check that the 3 nuts on the tach terminal studs behind the cluster, and the printed circuit connector to the cluster, are secure.
- With the **Ignition Switch** in the RUN position, check for battery voltage between the 2 o'clock terminal and the 6 o'clock terminal (as viewed from rear of cluster).
- Check for continuity from 6 o'clock terminal to G201.
- Disconnect the 2-terminal **Ignition Coil Connector**. Check for continuity between the DG/Y D wire and the 10 o'clock terminal.

## IGNITION HOW THE CIRCUIT WORKS

The basic **Ignition System** contains the breakerless **Ignition Module**, the **Ignition Coil**, the **Distributor**, and the spark plugs and wires.

When the engine is cranking or running:

- The magnetic pickup in the **Distributor** sends pulses to the **Ignition Module** as each tooth of the rotor passes the pickup.

The **Ignition Module** switches current on (ST) of the **Distributor**

**SATISFACTION 100% GUARANTEED**

**BUY IT NOW!**

**Click Here To Order**

ent makes a high-

PayPal American Express Discover Novus MasterCard VISA

- High voltage pulses are transmitted to the **Distributor**, which sends them to fire the spark plugs.

### CAUTION

*In the Dura Spark II system, a high-voltage pulse is produced when the Ignition Switch is turned OFF.*

## TROUBLESHOOTING HINTS

The following steps are intended only as quick checks to identify and locate some of the more frequent problems. If these checks do not solve the problem, refer to the **Ignition System** diagnosis procedure in the proper Ford Shop Manual for complete system tests.

If the **Ignition System** is OK, check the fuel system and the engine itself.

### PRELIMINARY CHECKS

- Check **Battery** for state of charge and for clean, tight battery terminal connections.
- Inspect all wires and connectors for breaks, cuts, abrasions or burned spots. Repair or replace as necessary. Make sure all wires are connected correctly.
- Unplug all connectors and inspect for corroded or burned contacts. Repair as necessary and plug connectors back together. Do NOT remove grease in connectors.
- Check for loose or damaged spark plug or coil wires. If boots or nipples are removed on 8mm ignition wires, reline inside of each with new silicone di-electric compound.

### SPECIAL TEST JUMPER

Make up a test jumper as shown in Figure 1 below. It is important to use only this test jumper when making these checks. Solid wire jumpers will not work for the quick checks.

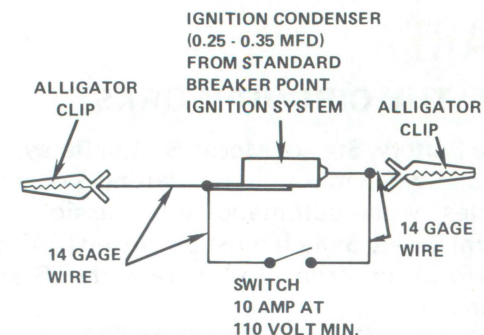

Figure 1 - Ignition Test Jumper

## RUN MODE SPARK TEST

### Step 1

- Remove **Distributor** cap and rotor from **Distributor**.
- Crank engine to align one tooth of armature (Figure 2) with magnet in pick-up coil (ignition OFF). Use a bump switch, or briefly touch a jumper between the R and R/LB terminals of the **Starter Relay**.
- Remove coil (center) wire from **Distributor** cap. Install modified spark plug (side electrode removed) in coil wire terminal.
- Turn **Ignition Switch** to RUN.
- Hold side of spark plug against engine block using insulated pliers. Tap base of **Distributor** with screwdriver handle and watch for **SPARK** at the spark plug.

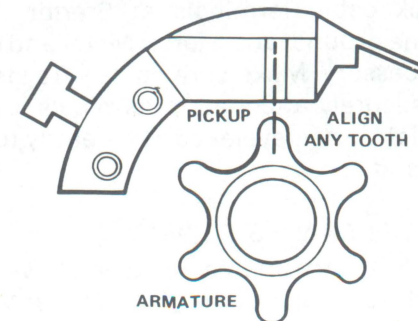

Figure 2 - Align Armature to Pickup

- If there is a good *SPARK*, primary circuit is OK. Skip to “START MODE SPARK TEST” below.
- If *NO GOOD SPARK*, perform **Step 2**.

## Step 2

- Unplug **C111** (4 wire connector) at **Ignition Module**.
- In the harness side of the connector, connect the special test jumper (Figure 1) between the **DG/Y D** lead and the **BK/LG D** or **BK** leads. Use paper clips on connector socket holes to make contact.
- With the **Ignition Switch** in **RUN**, close the test jumper switch. Leave closed for about one second, then open. Repeat this several times. There should be a *SPARK* each time this switch is opened.
  - If there is *NO SPARK*, the problem is in the primary circuit — the **Ignition Switch**, **Ignition Coil**, **DG/Y D** lead, **BK/LG D** or **BK** lead, **R/LG** lead, or ground connection in the **Distributor**. Perform **Step 3**.
  - If there is *SPARK*, the primary circuit wiring and **Coil** are OK. The problem is in the **Distributor** pick-up, the **Ignition Module** bias power feed (**R** wire), or the **Ignition Module**. Perform **Step 6**.

## Step 3

- Disconnect the test jumper lead from the **BK** or **BK/LG D** lead and connect to a good ground on the engine. Turn the test jumper switch **ON** and **OFF** several times as in **Step 2**.
  - If there is *NO SPARK*, the problem is in the **DG/Y D** lead, the **Coil**, or the coil feed circuit. Perform **Step 5**.

is in the  
ground  
Perform

## Step 4

- Connect an ohmmeter between the **BK** or **BK/LG D** lead and a good ground on the engine. With the meter on its lowest scale there should be no measurable resistance in the circuit.
  - If there is *RESISTANCE*, check ground connection in **Distributor** and **BK** or lead from module. Repair or replace as necessary. Remove meter plug in all connectors and repeat **Step 1**.
  - If there is *NO RESISTANCE*, the primary ground wiring is OK. Perform **Step 6**.

## Step 5

- Disconnect the test jumper from the **DG/Y D** lead and ground and connect it between the **Tach-Test** terminal of the coil and a good ground on the engine.
- With the **Ignition Switch** in **RUN**, turn the jumper switch **ON**. Hold it **ON** for approximately one second and turn it **OFF** as in **Step 2**. Repeat this several times. There should be a *SPARK* each time the switch is turned **OFF**.
  - If there is *NO SPARK*, the problem is in the coil or in the primary circuit through the **Ignition Switch** to the coil **BATT** terminal.
    - Check coil for internal shorts or opens and for primary resistance (1.13 to 1.23 ohms) and secondary resistance (**R/LG** wire) (7.7 to 9.3 K ohms). Replace coil if necessary.
    - Check coil feed circuit for opens, shorts, or high resistance. Repair as necessary. Remove test jumper, plug in connectors, and repeat **Step 1**.
  - If there is *SPARK*, the coil and its feed circuit are OK. The problem is in the **DG/Y D** lead between the coil and the module. Check for open or short and

repair as necessary. Remove test jumper. plug in all connectors, and repeat **Step 1**.

## Step 6

- Connect a voltmeter between the **O/Y H** and **P/LB H** leads on the harness side of the module 4-wire connector.

### CAUTION

If the vehicle has a catalytic converter, disconnect the air supply line between the Bypass Valve and the Manifold before cranking the engine with the Ignition Switch in OFF. This will prevent damage to the catalytic converter. After testing, run the engine for at least 3 minutes before reconnecting the air supply line to clear excess fuel from the exhaust system.

### NOTE

Do not use a voltmeter which is combined with a dwell-meter. Slight needle oscillations (½ volt) may not be detectable on this type of test unit.

- Set meter on its lowest scale and crank the engine. Meter needle should oscillate slightly (approximately ½ volt).
  - If meter needle does *NOT OSCILLATE*, check circuit through magnetic pick-up (in **Distributor**) for open, shorts, shorts to ground, and resistance. Resistance between **O/Y H** and **P/LB H** leads should be 400—1000 ohms and between each lead and ground should be more than 70K ohms. Repair as necessary, plug in all connectors, and repeat **Step 1**.

- If meter *OSCILLATES*, problem is in the power feed to the **Ignition Module (R wire)** or in the module itself. Perform **Step 7**.

## Step 7

- Remove all meters and jumpers. Plug in all connectors.
- Turn the **Ignition Switch** to RUN and measure voltage to engine ground at:
  - **Battery** positive terminal. This reading should be at least 12 volts.
  - The **R** lead of the **Ignition Module**. Use a straight pin to pierce the insulation of the lead and connect voltmeter to pin (Figure 3).
- These two readings should be within 1 volt of each other.
  - If readings are *NOT WITHIN ONE VOLT*, check circuit feeding power to **R** lead for shorts, open, or high resistance. Repair as necessary and repeat **Step 1**.
  - If readings are *WITHIN ONE VOLT*, the problem is probably in the module. Disconnect the module and connect a known-good module in its place and repeat **Step 1**. If this corrects the problem reconnect the original module and recheck. If problem returns, remove the old module and install the new one.

## START MODE SPARK TEST

### Step 1

- Remove coil wire from **Distributor** cap. Install modified spark plug (side electrode removed) in coil wire terminal.

- Hold side of spark plug against engine block using insulated pliers. Have someone crank engine (**Ignition Switch** to START).
  - If there is a *GOOD SPARK*, the problem is in the **Distributor** cap, rotor, ignition cable(s), or spark plug(s).
  - If *NO GOOD SPARK*, perform **Step 2**.

## Step 2

- Measure **Battery** voltage, and voltage at **W** wire of the module while cranking engine. Use a straight pin to pierce the wire (Figure 3).
- These two readings should be within 1 volt of each other.
  - If readings are *NOT WITHIN ONE VOLT*, check and repair the feed through the **Ignition Switch** to the **W** wire (**R/LB** lead). Recheck for spark (**Step 1**).
  - If readings *ARE WITHIN ONE VOLT*, or if there is still no spark after power feed to **W** wire is repaired, go on to **Step 3**.

## Step 3

- Measure coil BATT terminal voltage while cranking engine.
- Reading should be within 1 volt of battery voltage.
  - If reading is *NOT WITHIN ONE VOLT*, check and repair the feed through the **Ignition Switch** to the coil (**BR/PK, R/LG** leads). Recheck for spark (**Step 1**).
  - If reading is *WITHIN ONE VOLT*, the problem is in the **Ignition Module**. Plug in a known-good module and recheck for spark (**Step 1**). If this corrects the problem, reconnect the original module and recheck. If problem returns, remove the old module and install the new one.

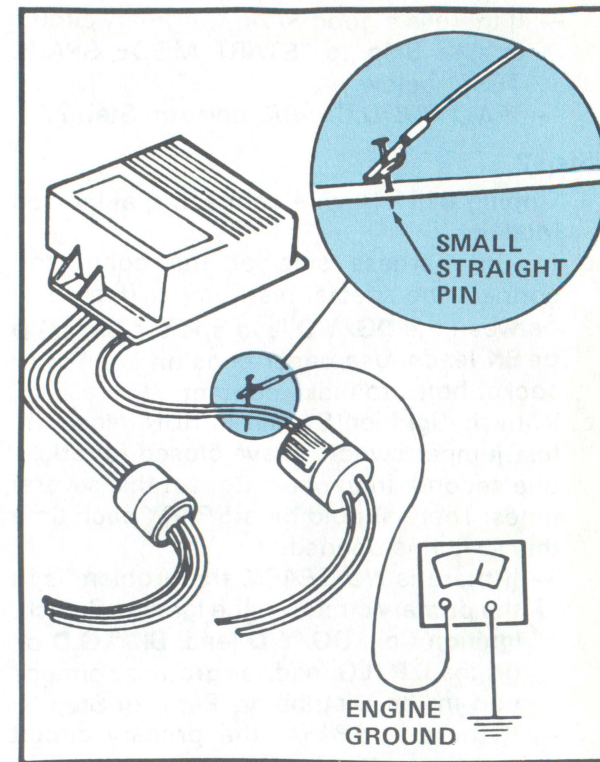

Figure 3 — Pin Test

### NOTE

If the above steps do not solve the problem, see "Engine Diagnosis and Service" section of the Shop Manual.

**100% SATISFACTION GUARANTEED**

BUY IT NOW!

Click Here To Order

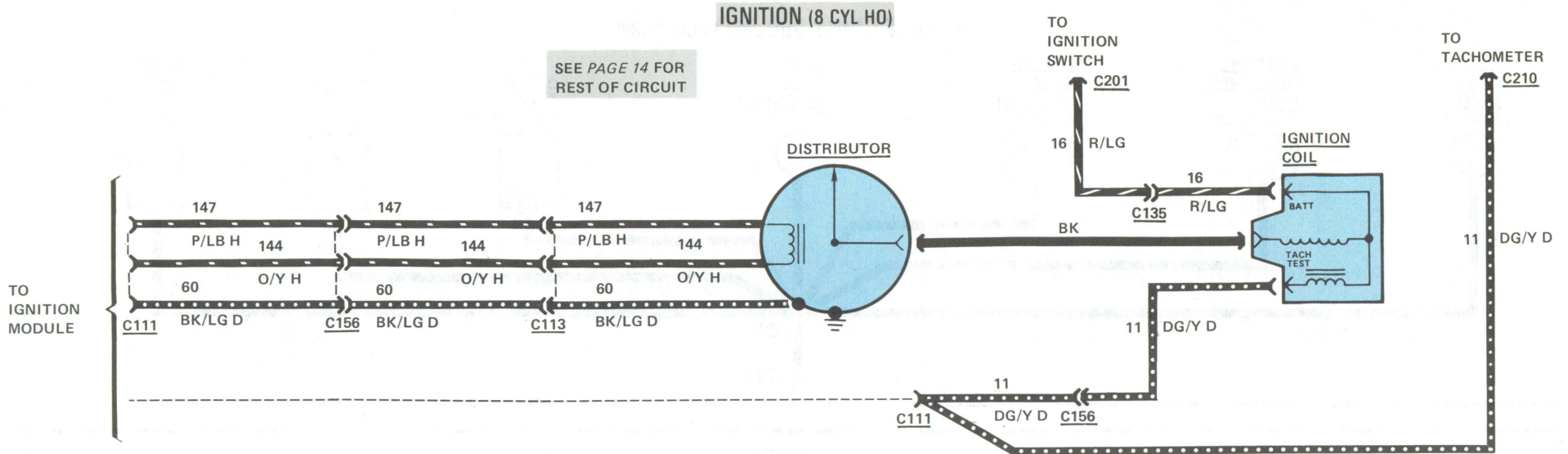

**LH FRONT LIGHTS GROUND (8 CYL CFI AND 8 CYL HO)**

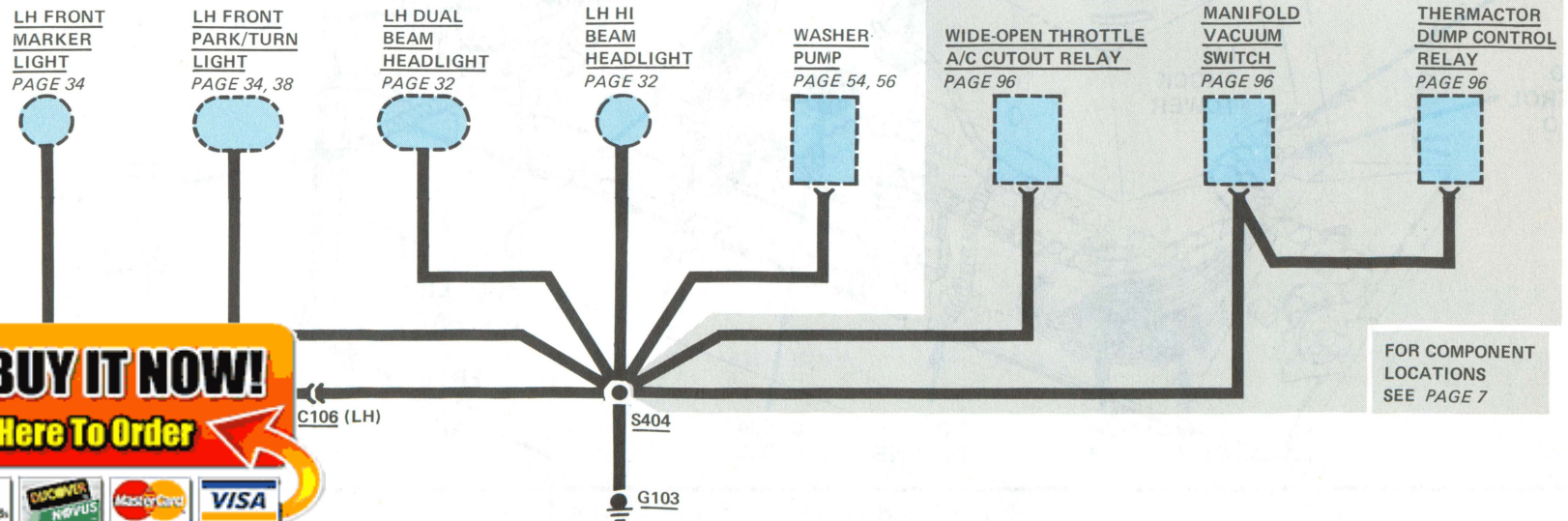

**100% SATISFACTION GUARANTEED**

**BUY IT NOW!**

**Click Here To Order**

PayPal, American Express, Discover, MasterCard, VISA

LH FRONT LIGHTS GROUND (4 CYL TURBO)

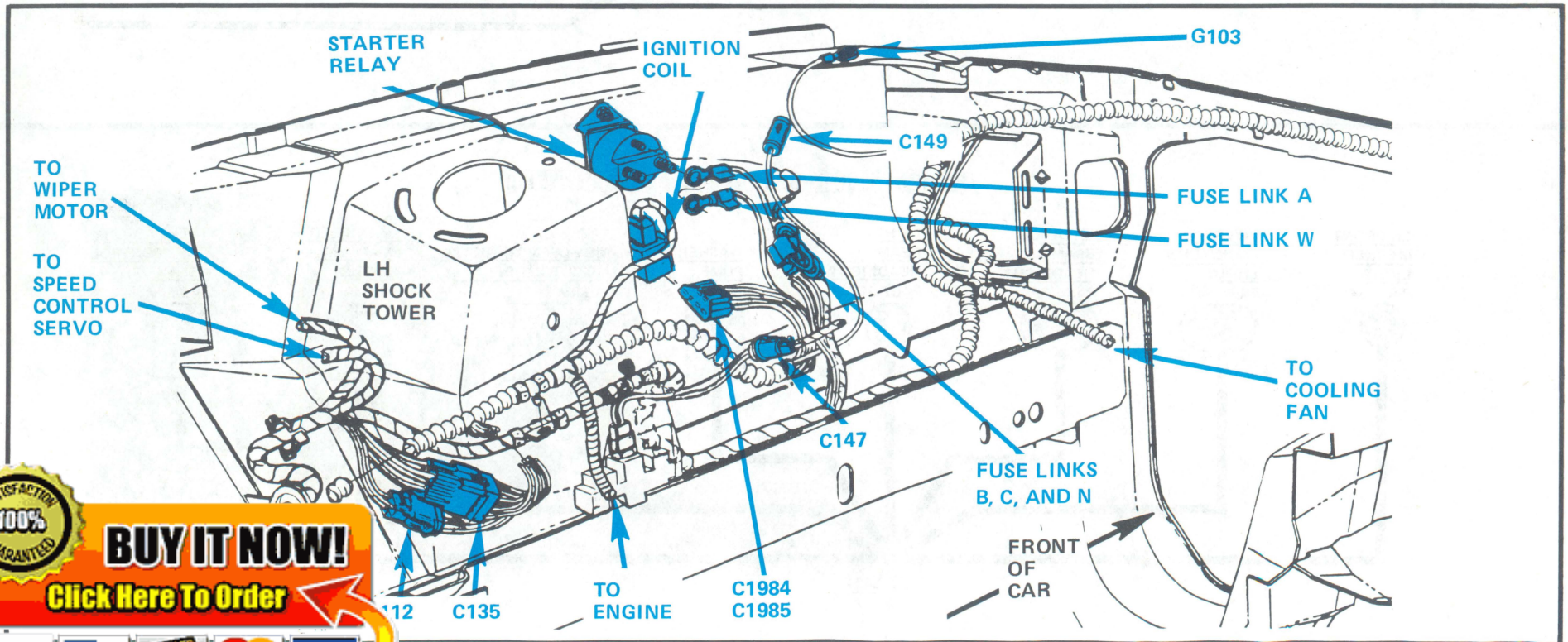
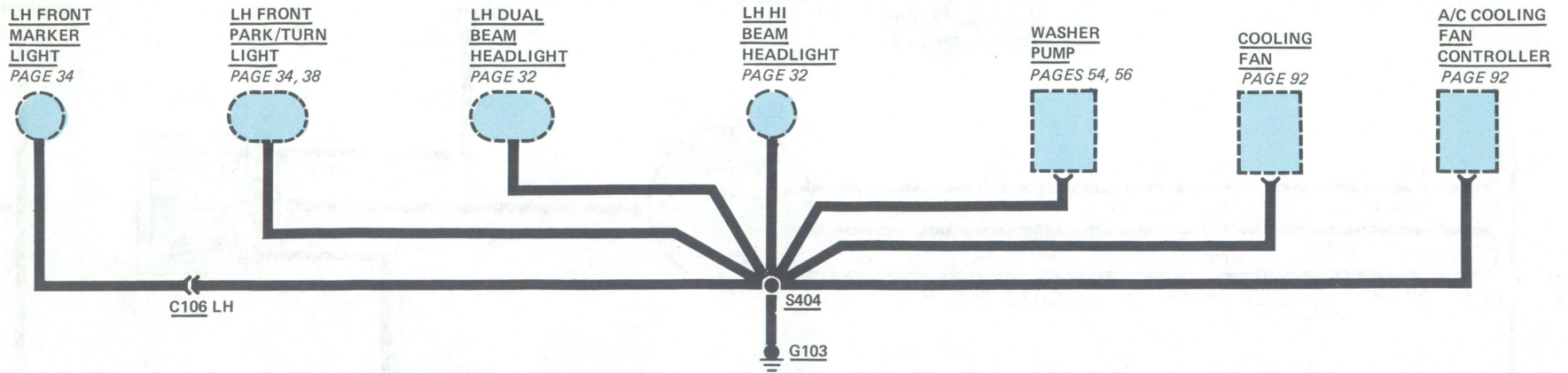

**100% SATISFACTION GUARANTEED**

**BUY IT NOW!**

[Click Here To Order](#)

Figure 1 - LH Fender Apron (4 CYL Turbo Engine)

LH FRONT LIGHTS GROUND (4 CYL 50 STATES AND CANADA)

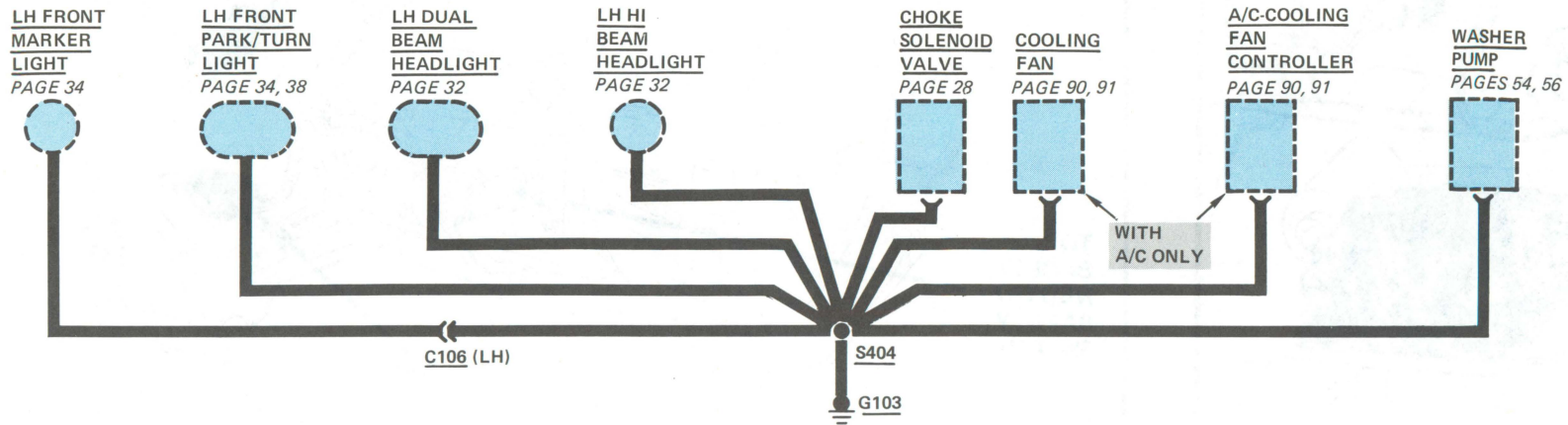

FOR COMPONENT LOCATIONS SEE PAGE 7

LH FRONT LIGHTS GROUND (6 CYL CFI)

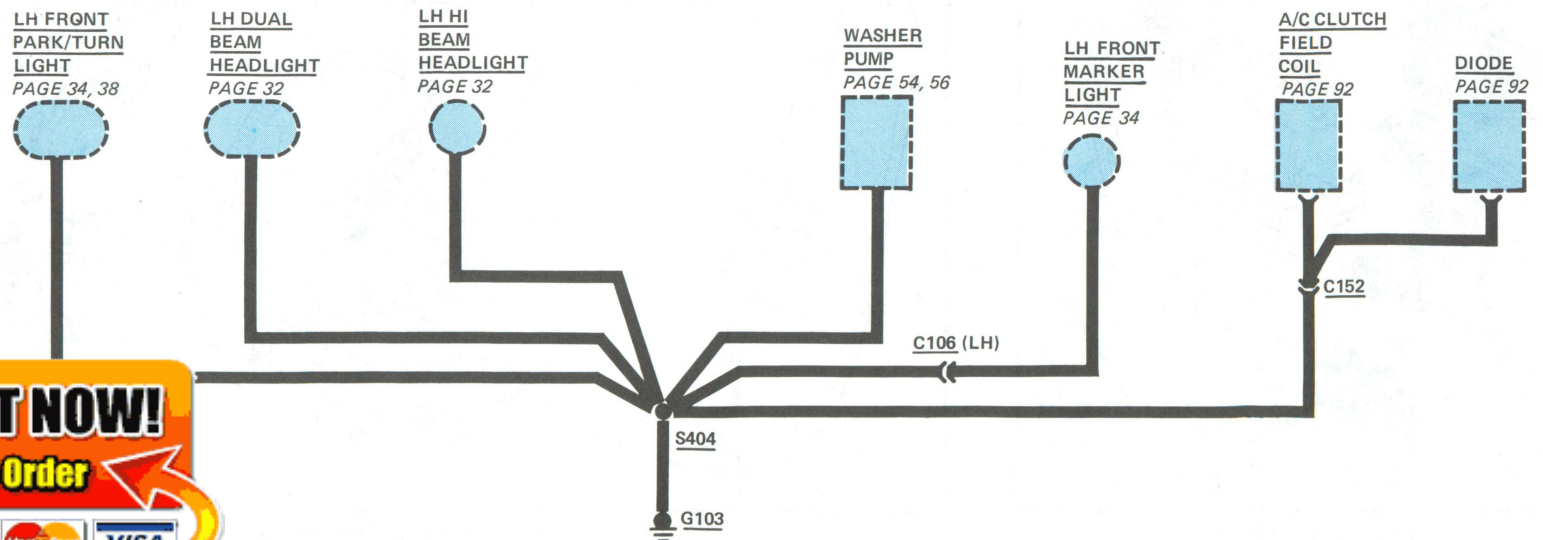

**100% SATISFACTION GUARANTEED**

**BUY IT NOW!**

**Click Here To Order**



**WE SUPPORT VOLUNTARY  
MECHANIC CERTIFICATION**



**Ford Parts and Service Division  
Training and Publications Department**