

100% MONEY BACK GUARANTEE

Click Here To Order

BUY IT NOW!

1983 MUSTANG/ CAPRI



DEMO

This DEMO contains only a few pages of the entire manual/product.

Not all Bookmarks work on the Demo, but they do on the full version.

Features:

- Searchable text
- Printable pages
- Bookmarked for easy navigation
- High Resolution images
- Zoom to see exact details
- Money back Guarantee
- Available on USB and eBook download

Electrical & Vacuum Trouble~ Shooting Manual



License #84356800

Copyright © 2023, Forel Publishing Company, LLC, Woodbridge, Virginia

All Rights Reserved. No part of this book may be used or reproduced in any manner whatsoever without written permission of Forel Publishing Company, LLC. For information write to Forel Publishing Company, LLC, Woodbridge, VA 22192

**1983 Mustang / Capri Electrical & Vacuum Trouble-
Shooting Manual (EVTM)
EAN: 978-1-60371-394-8
ISBN: 1-60371-394-8**

Forel Publishing Company, LLC
Woodbridge, VA 22192
Email: sales@ForelPublishing.com
<https://www.ForelPublishing.com>



This publication contains material that is reproduced and distributed under a license from Ford Motor Company. No further reproduction or distribution of the Ford Motor Company material is allowed without the express written permission of Ford Motor Company.

Note from the Publisher

This product was created from the original Ford Motor Company's publication. Every effort has been made to use the original scanned images, however, due to the condition of the material; some pages have been modified to remove imperfections.

Disclaimer

Although every effort was made to ensure the accuracy of this book, no representations or warranties of any kind are made concerning the accuracy, completeness or suitability of the information, either expressed or implied. As a result, the information contained within this book should be used as general information only. The author and Forel Publishing Company, LLC shall have neither liability nor responsibility to any person or entity with respect to any loss or damage caused, or alleged to be caused, directly or indirectly by the information contained in this book. Further, the publisher and author are not engaged in rendering legal or other professional services. If legal, mechanical, electrical, or other expert assistance is required, the professional should be sought.



How to Use This Manual	1
How to Find the Electrical Problem ...	2
Symbols (Electrical)	4
(Vacuum)	70
How to Find the Vacuum Problem	71
Component Testing	
Introduction	79
Light Switch	79
Ignition Switch	80
Multi-Function Switch	81
Windshield Wiper/Washer Switch ..	82
Interval Wiper/Washer Switch	83
A/C-Heater Function Control	84
A/C-Heater Blower Switch	85
Instrument Panel (Back View)	89
.....	
A/C-Heater	74
Brake Warning Indicator	46
Carburetor Circuits	19,20
Charge	10
Choke Heater	10
Cigar Lighter	52
Clock	52
Compressor Clutch Control	90, 92, 94
Coolant Temperature Gage	48
Cooling Fan Control	90, 92
Feedback Carburetor Control	23
Fuel Gage	48
Fuse Block	9
Gages	48
Graphic Warning Module	50
Grounds	6, 26
Heater	78
Horn	52
Heating Air Control	20
Interior Air Control	14
Kneeboard	44, 48
Luggage Rack	44
Luggage Tray	42
Luggage Tray	59
Luggage Tray	0, 58

NOTE
See Supplement for Electronic Fuel Injection (EFI Turbo) Circuits.

Lights	
Backup	41
Brake Indicator	46
Clock	44
Courtesy	42
Dome/Map	43
Exterior	34
Glove Box	42
Hazard	38
Headlights	32
Instrument Illumination	44
License	36
Map	43
Marker	34, 36
Park	34
Radio Illumination	44
Rear Park (Tail)	36
Stop	38, 40
Turn	38, 40
Light Switch	12
Low Fuel Warning	48
MCU	23
Power Distribution	10
Power Door Locks	60
Power Windows	62
Printed Circuit Board Connector (RH) ...	44
(LH) ...	48
Radio (Mono)	64
(Stereo/Tape)	65
(Premium Sound)	66
Rear Window Defrost	28
Restart Choke Control	29
Seatbelt Warning	46
Speed Control	72
Start	14
Tachometer	14

IMPORTANT SAFETY NOTICE

Appropriate service methods and proper repair procedures are essential for the safe, reliable operation of all motor vehicles, as well as the personal safety of the individual doing the work. This Manual provides general directions for accomplishing service and repair work with tested, effective techniques. Following them will help assure reliability.

There are numerous variations in procedures, techniques, tools, and parts for servicing vehicles, as well as in the skill of the individual doing the work. This Manual cannot possibly anticipate all such variations and provide advice or cautions as to each. Accordingly, anyone who departs from the instructions provided in this Manual must first establish that he compromises neither his personal safety nor the vehicle integrity by his choice of methods, tools or parts.

Trunk Release	59
Upshift Indicator	30
Vacuum Distribution	69
Warning Indicators	46
Windshield Wiper/Washer	54
Wiper/Washer (Interval)	56

100% SATISFACTION GUARANTEED

BUY IT NOW!

Click Here To Order

PayPal Discover MasterCard VISA

The purpose of this manual is to show electrical and vacuum circuits of these vehicles in a clear and simple fashion to make troubleshooting easier. With each circuit is a description of *How the Circuit Works* and some *Troubleshooting Hints*. A *Component Location* chart lists components, connectors, and references to pictures in the manual.

Wiring Diagrams give a schematic picture of when and how the circuit is powered, what the current path is to circuit components, and how the circuit is grounded. Each circuit component is named (underlined titles). Wire and connector colors are listed (standard Ford color abbreviations are used):

COLOR ABBREVIATIONS

BL	Blue	N	Natural
BK	Black	O	Orange
BR	Brown	PK	Pink
DB	Dark Blue	P	Purple
DG	Dark Green	R	Red
GR	Green	T	Tan
GY	Gray	W	White
LB	Light Blue	Y	Yellow
LG	Light Green		

Where two colors are shown for a wire, the first color is the basic color of the wire. The second color is the dot, hash, or stripe marking. If **D** or **H** is given, the second color is dots or hash marks. If there is no letter after the second color, the wire has a stripe.

e stripe.
sh marks.

Connector end views of switches and other components are shown to help with bench testing. The views show the harness wire colors that connect to the mating terminals. Connector colors and locations are shown in the *Component Location* chart. Two-color listings indicate separate colors for each connector half.

Components which work together are shown together. For example, all electrical components used in any circuit are shown on one diagram. The circuit breaker or fuse is shown at the top of the page. All wires, connectors, splices, switches, and motors are shown in the flow of current to ground at the bottom of the page. Notes are included which describe how switches and other components work. If a component is used in several different circuits, it is shown in several places. For example, the **Light Switch** is an electrical part of many circuits and is repeated on many pages. In some cases, however, a component may seem by its name to belong on a page where it has no electrical connection. For example, **Radio Illumination** is electrically part of **Instrument Illumination**. Since it has no electrical connection at all with the actual **Radio** circuit, it is not shown on the **Radio** page.

Troubleshooting Hints point the technician in a general direction, but are not intended as a step-by-step procedure. Ignition troubleshooting is an exception to this. It includes a step-by-step procedure of basic quick checks to locate some of the more common **Ignition System** problems. Read the Shop Manual for more detailed repair procedures.

The **Grounds** pages show detailed views of multiple component ground points. This is useful for checking interconnections among the ground circuits of different diagrams.

Notes, Cautions, and Warnings appear in boxes on text pages and contain important car and mechanic safety information.

Notes give added information to help complete a particular procedure. Cautions are included to prevent making an error that could damage the vehicle. Warnings highlight areas where carelessness can cause personal injury. The following list contains some general **Warnings** that should be followed when working on a vehicle.

- Always wear safety glasses for eye protection.
- Use safety stands whenever a procedure requires being under a vehicle.
- Be sure that the **Ignition Switch** is always in the OFF position, unless otherwise required by the procedure.
- Set the parking brake when working on any vehicle. An automatic transmission should be in PARK. A manual transmission should be in NEUTRAL.
- Operate the engine only in a well-ventilated area to avoid the danger of carbon monoxide.
- Keep away from moving parts when the engine is running, especially the fan and belts.
- To prevent serious burns, avoid contact with hot metal parts such as the radiator, exhaust manifold, tail pipe, catalytic converter, and muffler.
- Do not allow flame or sparks near the battery. Gases are always present in and around the battery cell. An explosion could occur.
- Do not smoke.
- To avoid injury, always remove rings, watches, loose hanging jewelry, and loose clothing.

100% SATISFACTION GUARANTEED

BUY IT NOW!

Click Here To Order

PayPal American Express Discover MasterCard VISA

2 HOW TO FIND THE ELECTRICAL PROBLEM

TROUBLESHOOTING STEPS

These six steps present an orderly method of troubleshooting:

Step 1. Verify the problem.

- Operate the complete system and see all symptoms for yourself in order to:
 - check the accuracy and completeness of the customer's complaint.
 - learn more that might give a clue to the nature and location of the problem.

Step 2. Narrow the problem.

- Using the EVTM, narrow down the possible causes and locations of the problem in order to more quickly find the exact cause.
- Read the description of *How the Circuit Works* and study the wiring diagram. You should then know enough about the circuit operation to figure out where to check for this trouble.

Step 3. Test the cause.

- Use electrical test procedures to find the specific cause of the symptoms.
- *Troubleshooting Hints* will give some helpful ideas.
- The *Component Location* charts and the pictures will help you find components, grounds, and connectors.

Step 4. Verify the cause.

- Confirm the fact that you have found the correct cause through operating the parts of the circuit you think are good.

Step 5. Make the repair.

- Repair or replace the faulty component.

Step 6. Verify the repair.

Operate the system as in Step 1 and check for symptoms. If the symptoms are new

Special test equipment and special procedures are the same as the ones you use for

details. You will find the circuits in this manual to be helpful with these special tests.

TROUBLESHOOTING TOOLS

JUMPER WIRE

This is a test lead used to connect two points of a circuit. A **Jumper Wire** can complete a circuit by bypassing an open.

Uses: Bypassing Switches or Open Circuits

WARNING

Never use a jumper wire across high resistance loads (motors, etc.) connected between hot and ground. This direct battery short may cause injury or fire.

VOLTMETER

A DC **Voltmeter** measures circuit voltage. Connect negative (- or black) lead to ground, and positive (+ or red) lead to voltage measuring point.

OHMMETER

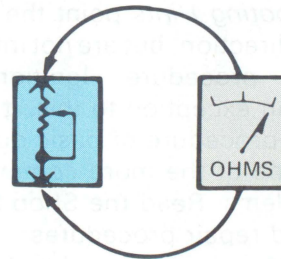

Figure 1— Resistance Check

An **Ohmmeter** shows the resistance between two connected points (Figure 1).

TEST LIGHT

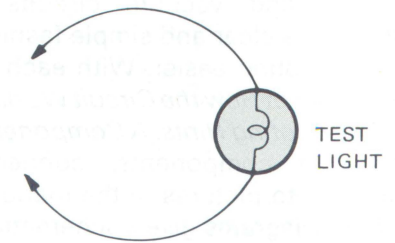

Figure 2 – Test Light

A **Test Light** is a 12-volt bulb with two test leads (Figure 2).

Uses: Voltage Check. Short Check

SELF-POWERED TEST LIGHT

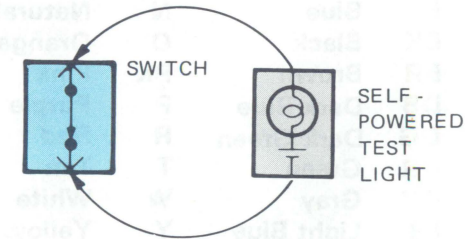

Figure 3—Continuity Check

The **Self-Powered Test Light** is a bulb, battery and set of test leads wired in series (Figure 3). When connected to two points of a continuous circuit, the bulb glows.

Uses: Continuity Check. Ground Check

CAUTION

When using a self-powered test light or ohmmeter, be sure power is off in circuit during testing. Hot circuits can cause equipment damage and false readings.

100% SATISFACTION GUARANTEED

BUY IT NOW!

Click Here To Order

Special test equipment and special procedures are the same as the ones you use for

PayPal American Express Discover MasterCard VISA

TROUBLESHOOTING CHECKS

SWITCH CIRCUIT CHECK

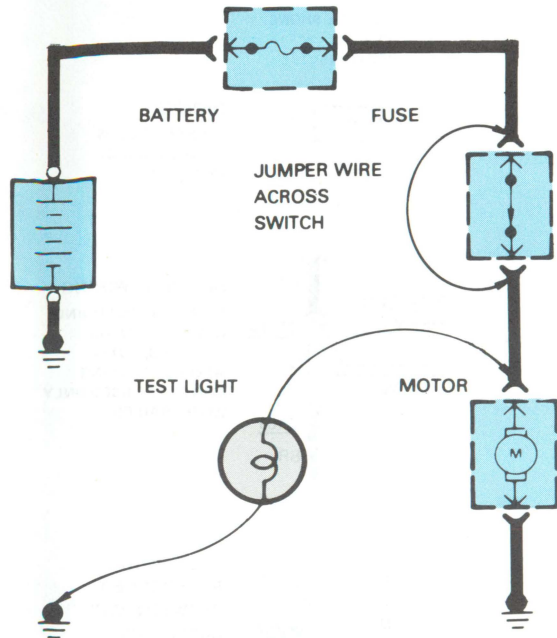

Figure 4—Switch Circuit Check and Voltage Check

In a bad circuit with a switch in series with the load, jumper the terminals of the switch to power the load. If jumping the terminals powers the circuit, the switch is bad (Figure 4).

CONTINUITY CHECK (Locating open circuits)

Connect one lead of **Self-Powered Test Light** or **Ohmmeter** to each end of circuit (Figure 3). Light will glow if circuit is closed. Switches and fuses can be checked in the same way.

100% SATISFACTION GUARANTEED

BUY IT NOW!

Click Here To Order

known battery
the other
en the

SHORT CHECK (short to ground)

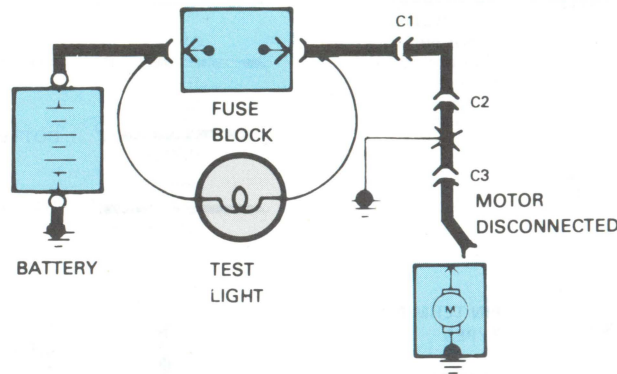

Figure 5—Short Check

A fuse that repeatedly blows is usually caused by a short to ground. It's important to be able to locate such a short quickly (Figure 5).

- 1) Turn off everything powered through the fuse.
- 2) Disconnect other loads powered through the fuse:
 - Motors: disconnect motor connector.
 - Lights: remove bulbs.
- 3) Turn **Ignition Switch** to RUN (if necessary) to power fuse.
- 4) Connect one **Test Light** lead to hot end of blown fuse. Connect other lead to ground. Bulb should glow showing power to fuse. *(This step is just a check to be sure you have power to the circuit.)*
- 5) Disconnect the **Test Light** lead from ground and reconnect it to the load side of the fuse.
 - If the **Test Light** is off, the short is in the disconnected equipment.
 - If the **Test Light** goes on, the short is in the wiring. You must find the short by disconnecting the circuit connectors one at a time until the **Test Light** goes out. For example: with a ground at X, the bulb goes out when C1 or C2 is disconnected, but stays on after disconnecting C3. This

means the ground is between C2 and C3.

"GOOD GROUND" CHECK

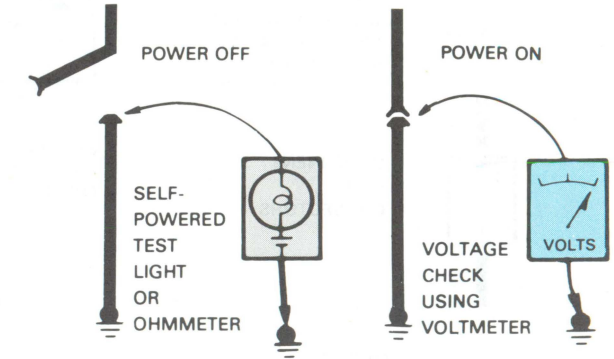

Figure 6 — Grounds Checks

Turn on power to circuit. Perform Voltage Check between suspected bad ground and frame. Any voltage means ground is bad.

Turn off power to circuit. Connect one lead of **Self-Powered Test Light** or **Ohmmeter** to wire in question, and the other to known ground. If bulb glows, circuit ground is OK (Figure 6).

TROUBLESHOOTING HINTS

The circuit schematics in this manual are designed to make it easy to identify common points in circuits. This knowledge can help narrow the problem to a specific area. For example, if several circuits fail at the same time, check for a common power or ground connection. (See *Power Distribution* or *Grounds*). If part of a circuit fails, check the connections between the part that works and the part that doesn't work.

For example, if low beam headlights work, but high beams and the indicator light don't work, then power and ground paths must be good. Since the dimmer switch is the component which switches this power to the high beam lights and indicator, it is most likely the cause of failure.

4 ELECTRICAL SYMBOLS

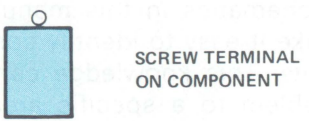
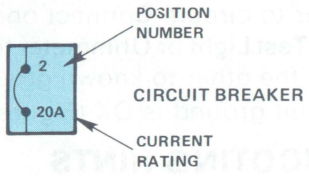
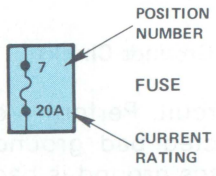
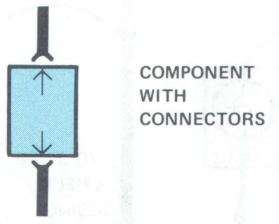
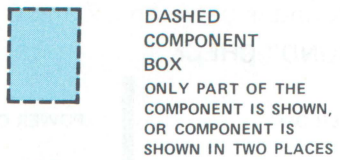

SOLID STATE

SEALED ELECTRONIC COMPONENT ANY CIRCUITRY SHOWN INSIDE THE

BUY IT NOW!

Click Here To Order

100% SATISFACTION GUARANTEED

PayPal American Express Discover/Novus MasterCard VISA

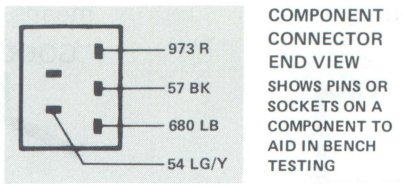

WIRE COLORS ARE LABELED FOR MATING HARNESS CONNECTOR

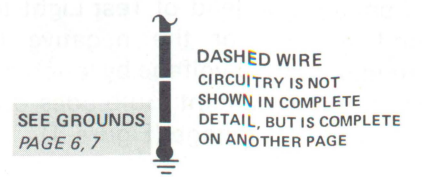
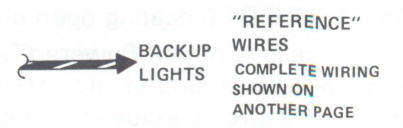
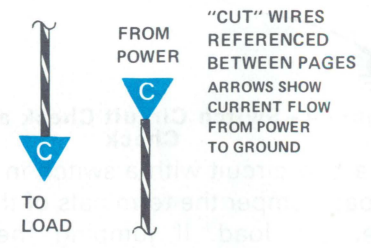
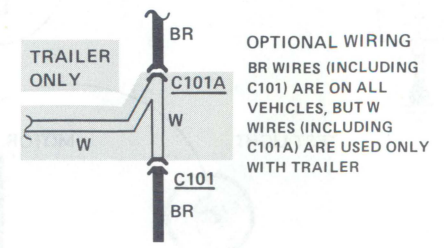
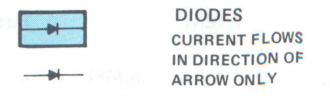
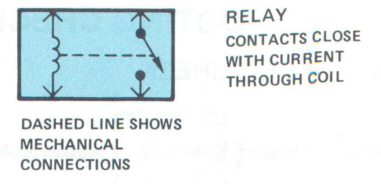
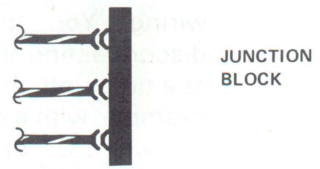
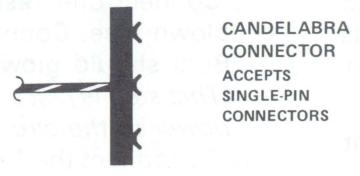
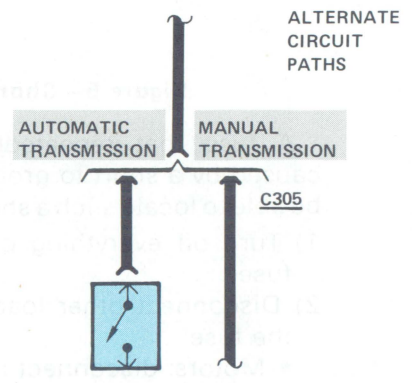
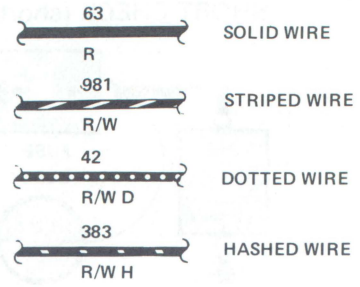
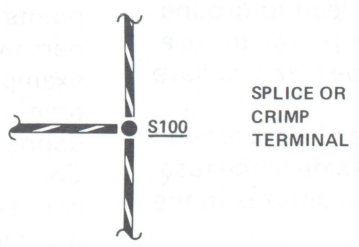
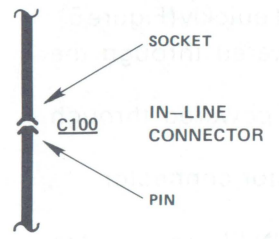

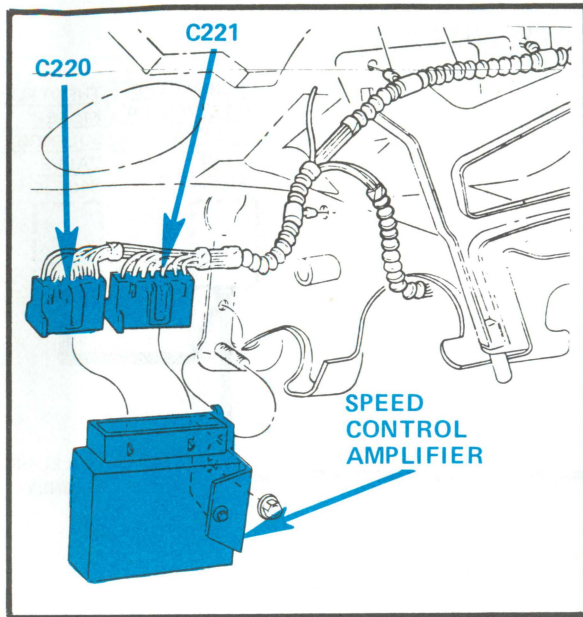

Figure 1 - LH Cowl Area

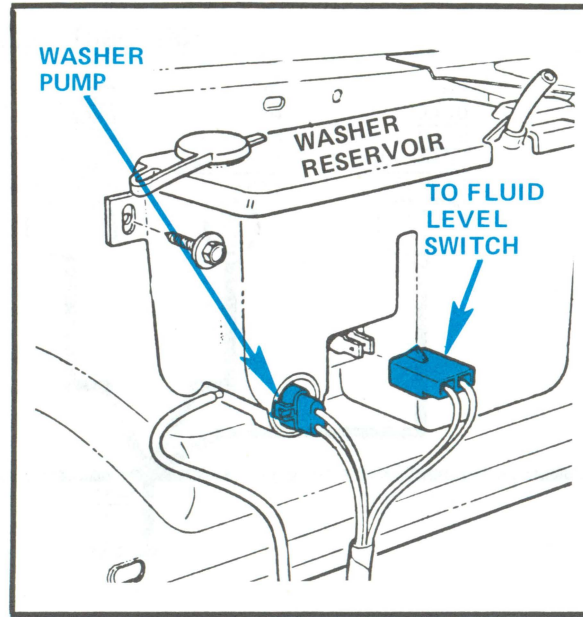

Figure 2 - LH Engine Cowl

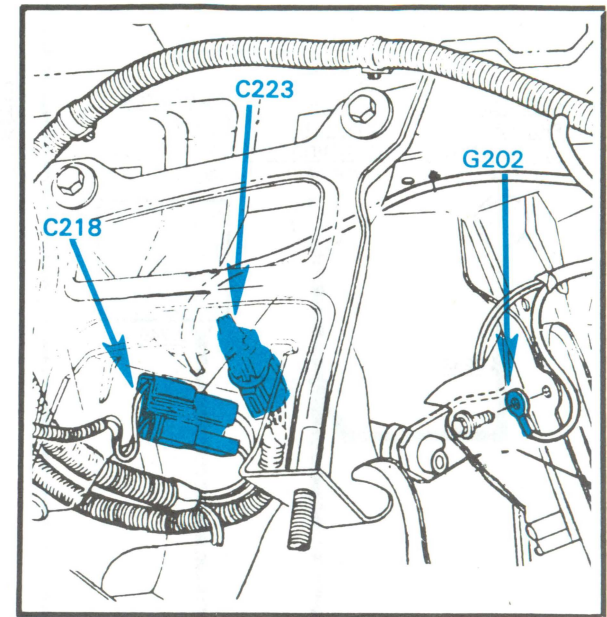

Figure 3 - Under LH Side of I/P

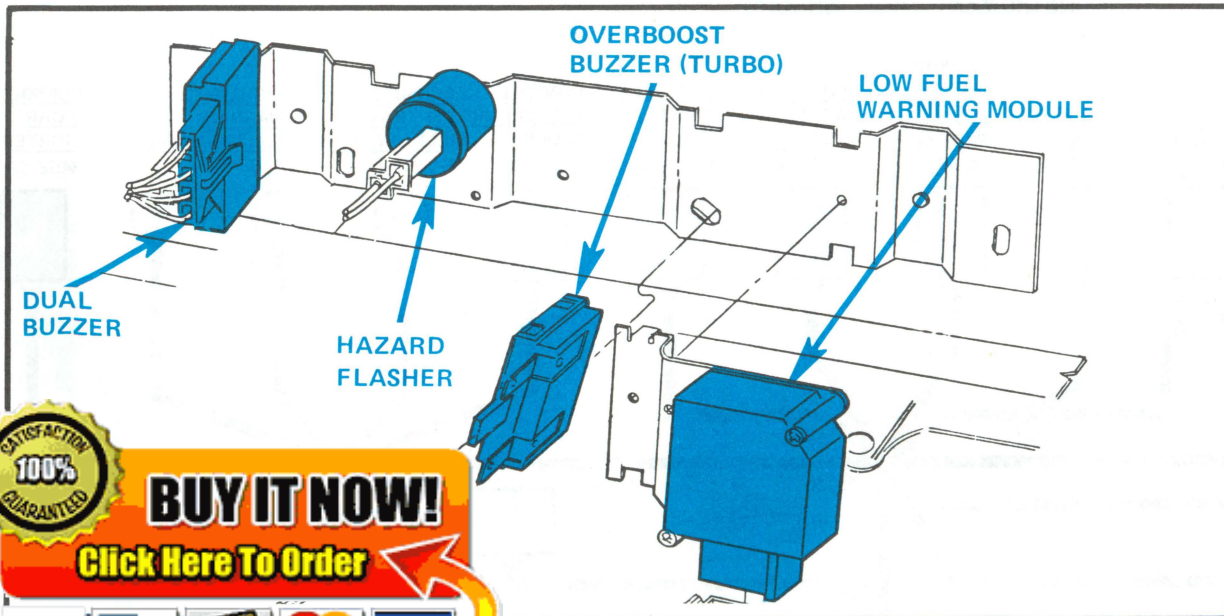

Figure 4 - Behind RH Side of I/P

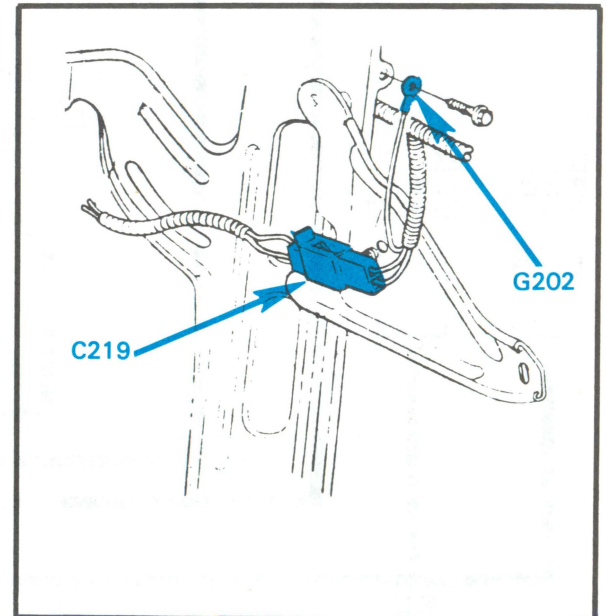

Figure 5 - Under LH Side Of I/P

100% SATISFACTION GUARANTEED

BUY IT NOW!

Click Here To Order

PayPal, American Express, Discover, MasterCard, VISA

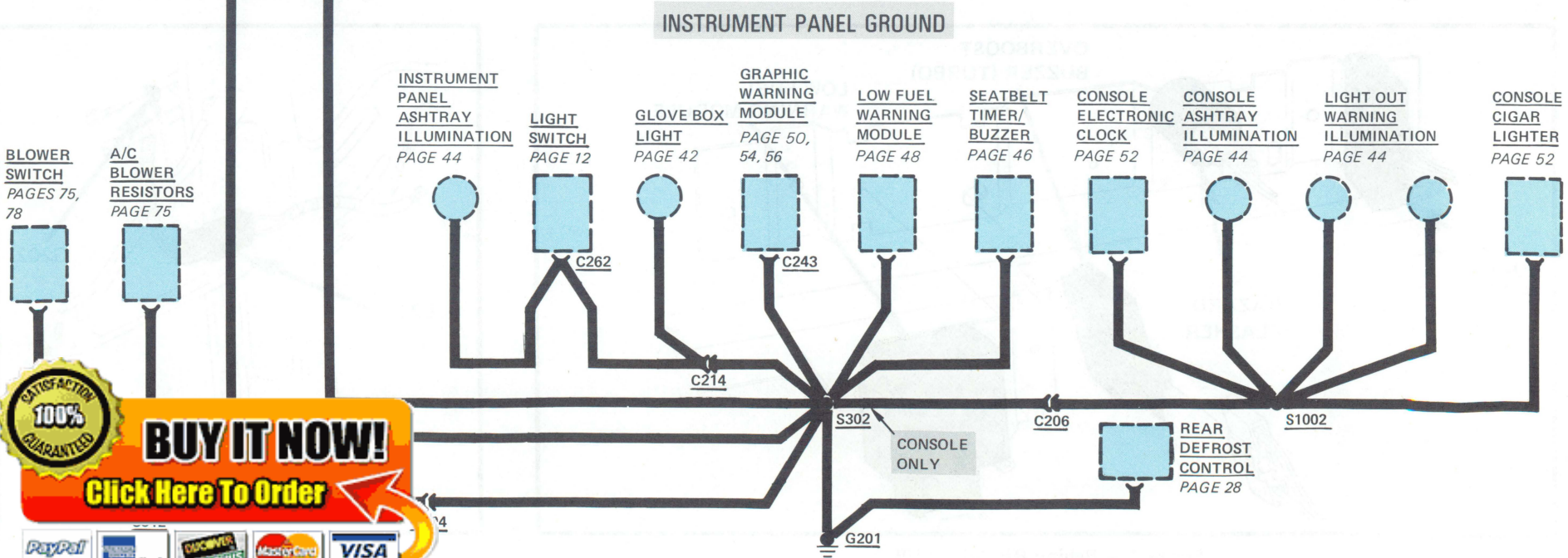
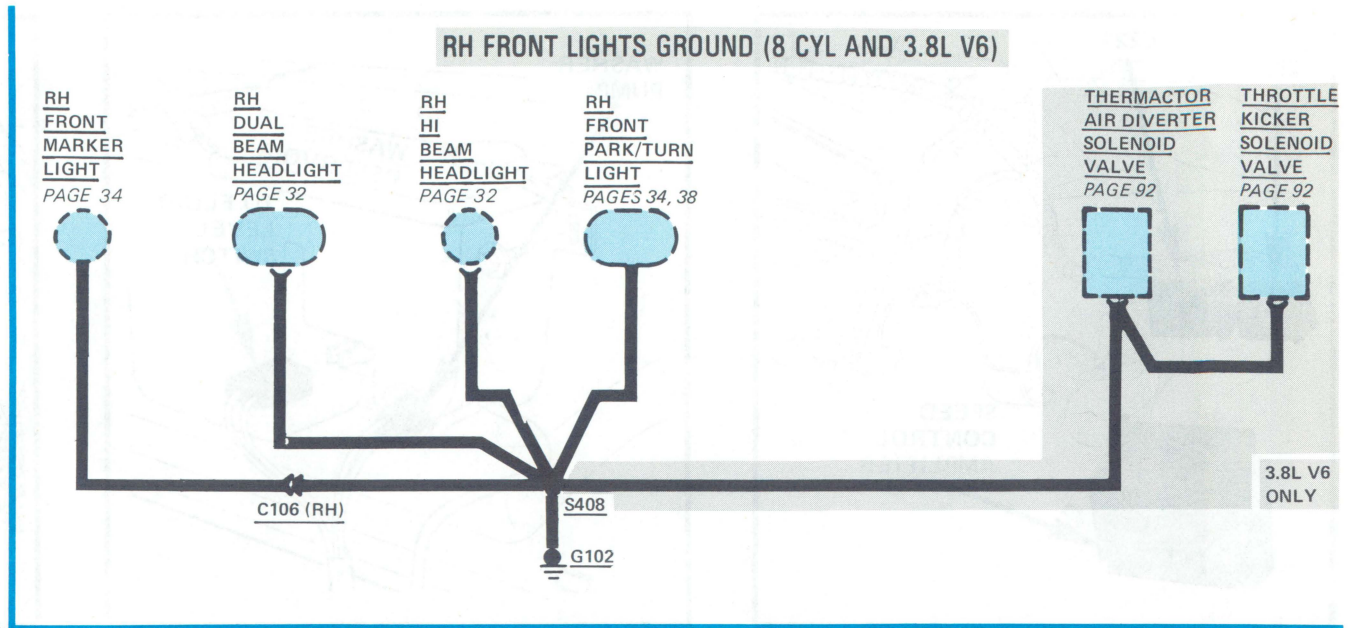

100% SATISFACTION GUARANTEED

BUY IT NOW!

Click Here To Order

The ground circuits shown here are complete, and connect several components together to screw terminal ground points. On other pages only parts of these circuits may be shown. Partial ground circuits are shown dashed on those pages.

All simple or component ground circuits are shown on the individual circuit pages, and are complete on those pages.

All wires are **57 BK** unless otherwise noted.

COMPONENT LOCATION

		Page-Figure	Color	Terminals
Connector C106	Near both RH and LH side markers	33-1	BR	2
Connector C152	LH fender apron		BL	1
Connector C204	Behind RH side of I/P above glove box	78-1	GY	4
Connector C206	Attached behind graphic warning module	51-1	GY	4
Connector C214	Clipped to LH I/P support brace	45-3	GY	
Connector C241	Behind center of I/P above radio	78-1	BR	2
Connector C243	Attached to graphic warning module	51-1	GY	8
Connector C246	Behind LH side of I/P on instrument cluster	89-1	GY	14
Connector C263	Near transmission support brace			2
Connector C312	LH side of transmission hump	47-1	GY	
Ground G102	Top RH side of radiator support	33-1		
Ground G103	Top LH side of radiator support	33-1		
Ground G117	At engine ground bracket	22-1		
Ground G201	Behind LH side glove box	45-1		
Ground G301	LH side trunk lid striker	35-2		

NOTE

See REAR LIGHTS GROUND on Page 26.
See LH FRONT LIGHTS GROUND on Page 27.

RH FRONT LIGHTS GROUND (4 CYL)

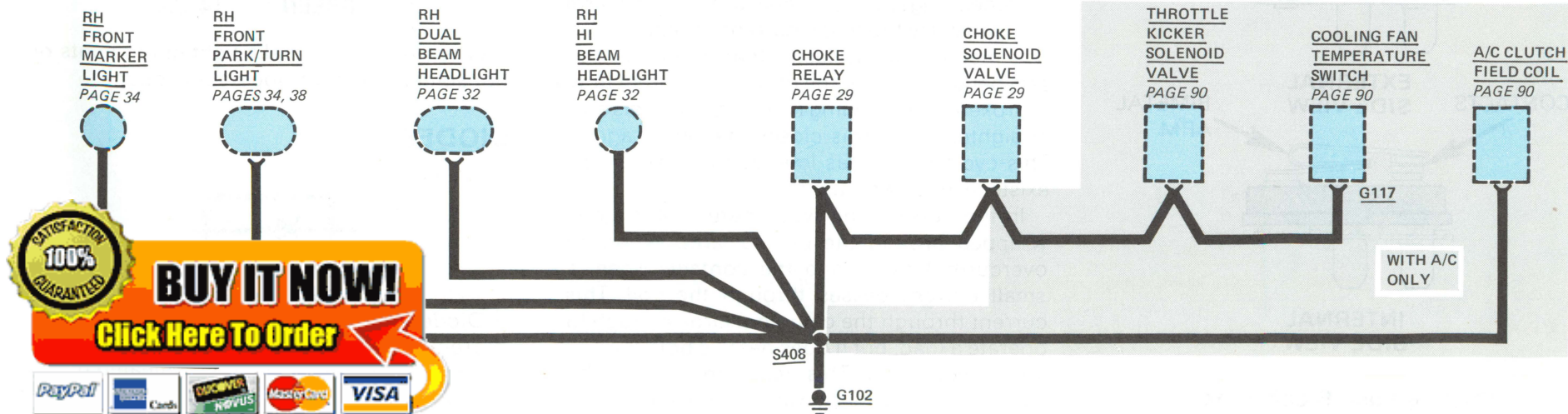

REPLACEMENT OF FUSES/ CIRCUIT BREAKERS

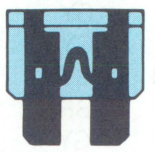

GOOD FUSE

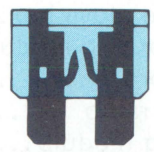

BLOWN FUSE

Fuses are mounted either in the **Fuse Block** or in-line. They are identified by the numbered value in amperes, and by a color code. Some positions may have either a fuse with adapter or a circuit breaker. Be sure to replace a fuse or circuit breaker with the same kind of unit and with the same ampere rating. Remove fuses in order to check them.

CIRCUIT BREAKER OPERATION

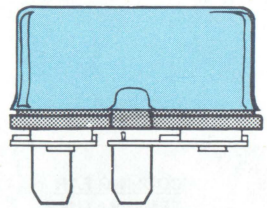

EXTERNAL
SIDE VIEW

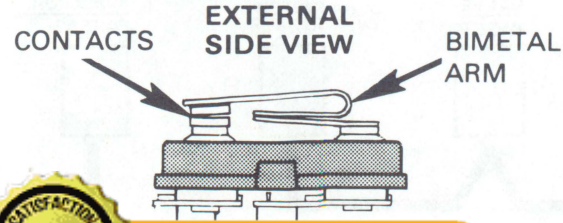

CONTACTS

BIMETAL
ARM

100% GUARANTEED

BUY IT NOW!

Click Here To Order

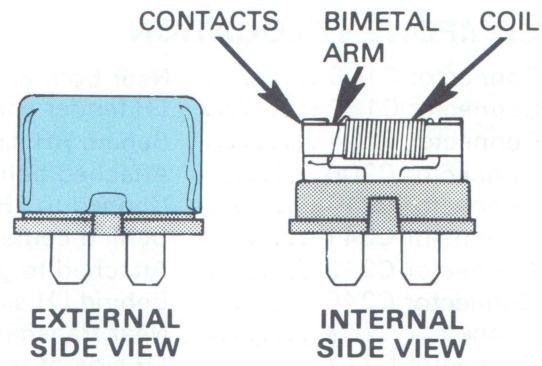

EXTERNAL
SIDE VIEW

INTERNAL
SIDE VIEW

Non-Cycling Fuse Block Type

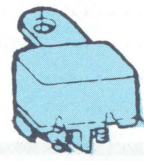

Cycling In-Line Type

Some circuits are protected by circuit breakers. (Abbreviated "c.b." in fuse chart.) They can be **Fuse Block** mounted or in-line. Like fuses, they are rated in amperes.

Each circuit breaker conducts current through an arm made of two types of metal fastened together (bimetal arm). If the arm starts to carry too much current, it heats up. As one metal expands faster than the other the arm bends, opening the contacts. Current flow is broken. In the cycling type, the arm cools and straightens out. This closes the circuit again. This cycle repeats as long as the overcurrent exists, with power applied.

In the non-cycling type, there is also a coil wrapped around the bimetal arm. When an overcurrent exists and the contacts open, a small current passes through the coil. This current through the coil is not large enough to operate a load, but it does heat up both the coil and bimetal arm. This keeps the arm in the open position until power is removed.

FUSE LINKS

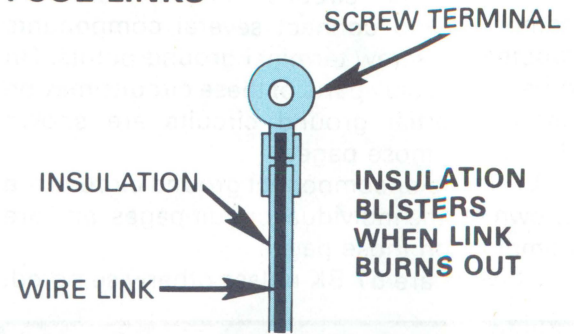

The fuse link is a short length of wire smaller in gage than the wire in the protected circuit. The wire is covered with a thick non-flammable insulation. An overload causes the link to heat and the insulation to blister. If the overload remains, the link will melt, causing an open circuit. The links are color coded for wire size as follows:

COLOR CODE

BLUE	20 GA
BROWN	18 GA
BLACK	16 GA
GREEN	14 GA

When replacing, make tight crimp joints or hot solder joints for good connections.

DIODES

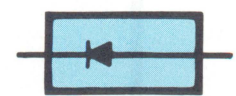

Diodes are electrical devices that permit current to flow in one direction only. The current flows in the direction indicated by the arrow.

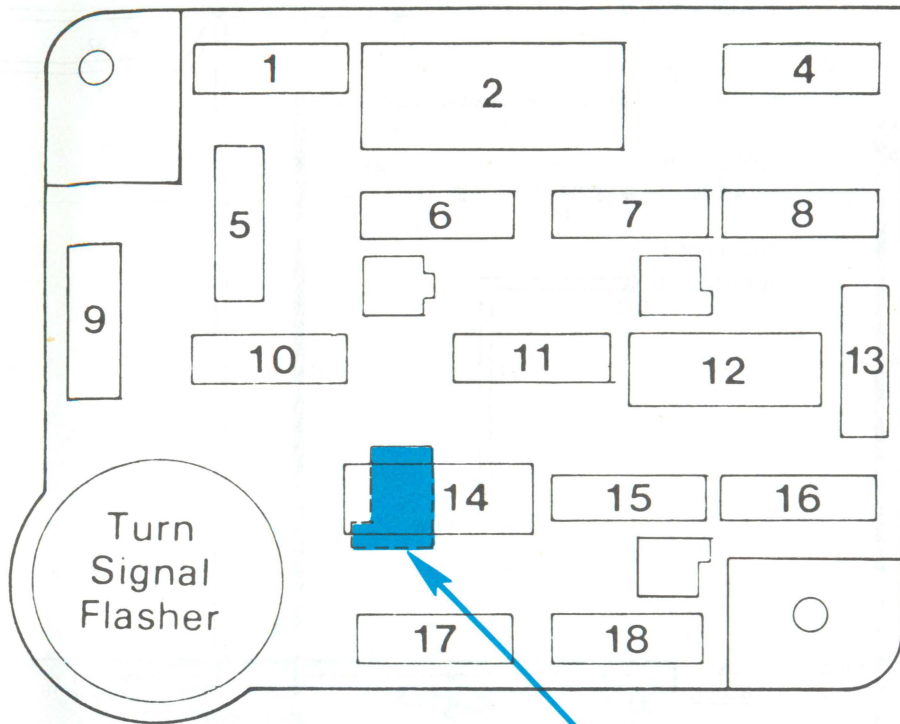

C257

Fuse Value Amps	Color Code
4	Pink
5	Tan
10	Red

100% SATISFACTION GUARANTEED

BUY IT NOW!

Click Here To Order

Power Distribution

The **alternator** and **Battery** are connected together at the **Starter Relay** hot terminal. Other circuits originate at the **Starter Relay** hot terminal and are protected by fuse links. Low power circuits are also protected by fuses.

Fuse Position	Amps	Circuits Protected
1	15	Stop/Hazard Lights; Speed Control
2	6 c.b.	Windshield Wiper/Washer; Interval Wiper
4	10	Exterior Lights; Instrument Illumination
5	15	Turn Lights; Backup Lights
6	20	A/C Clutch; Speed Control; Rear Window Defrost; Trunk Release; Digital Clock; Light Out Warning.
7	—	(Not used)
8	15	Courtesy Lights; Clock; Key Warning
9	15 or 30	Heater Blower (15 amps); A/C Blower (30 amps)
10	20	Passing Beam
11	15	Radio, Premium Sound
12	—	(Not used)
13	5	Instrument Illumination
14	20 c.b.	Power Windows
15	—	(Not used)
16	20	Horn; Cigar Lighter; Digital Clock
17	—	(Not Used)
18	10	Seatbelt Buzzer; Warning Indicators; Carburetor Circuits; Tachometer; Low Fuel Warning; Idle Tracking Air Control; Restart Choke Control; Cooling Fan/Compressor Clutch Control.

The **Ignition Switch** and **Light Switch** are powered at all times as are **Fuses 1, 4, 8, 10** and **16**. The other fuses are powered through the **Ignition Switch** or the **Light Switch**.

Position **3** is not used, and is covered by **Covered Breaker 2**.

10 CHARGE/POWER DISTRIBUTION

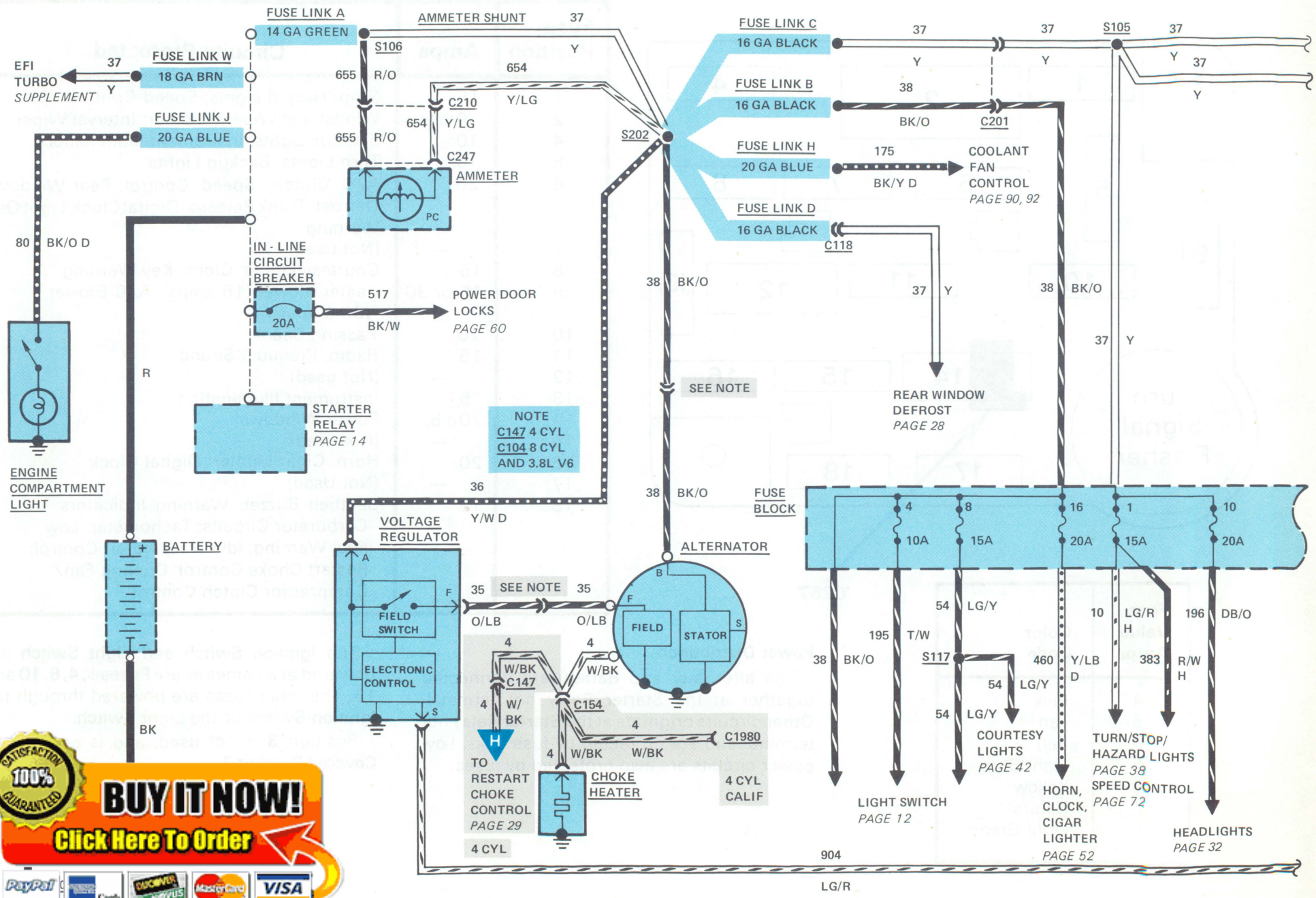

100% SATISFACTION GUARANTEED

BUY IT NOW!

Click Here To Order

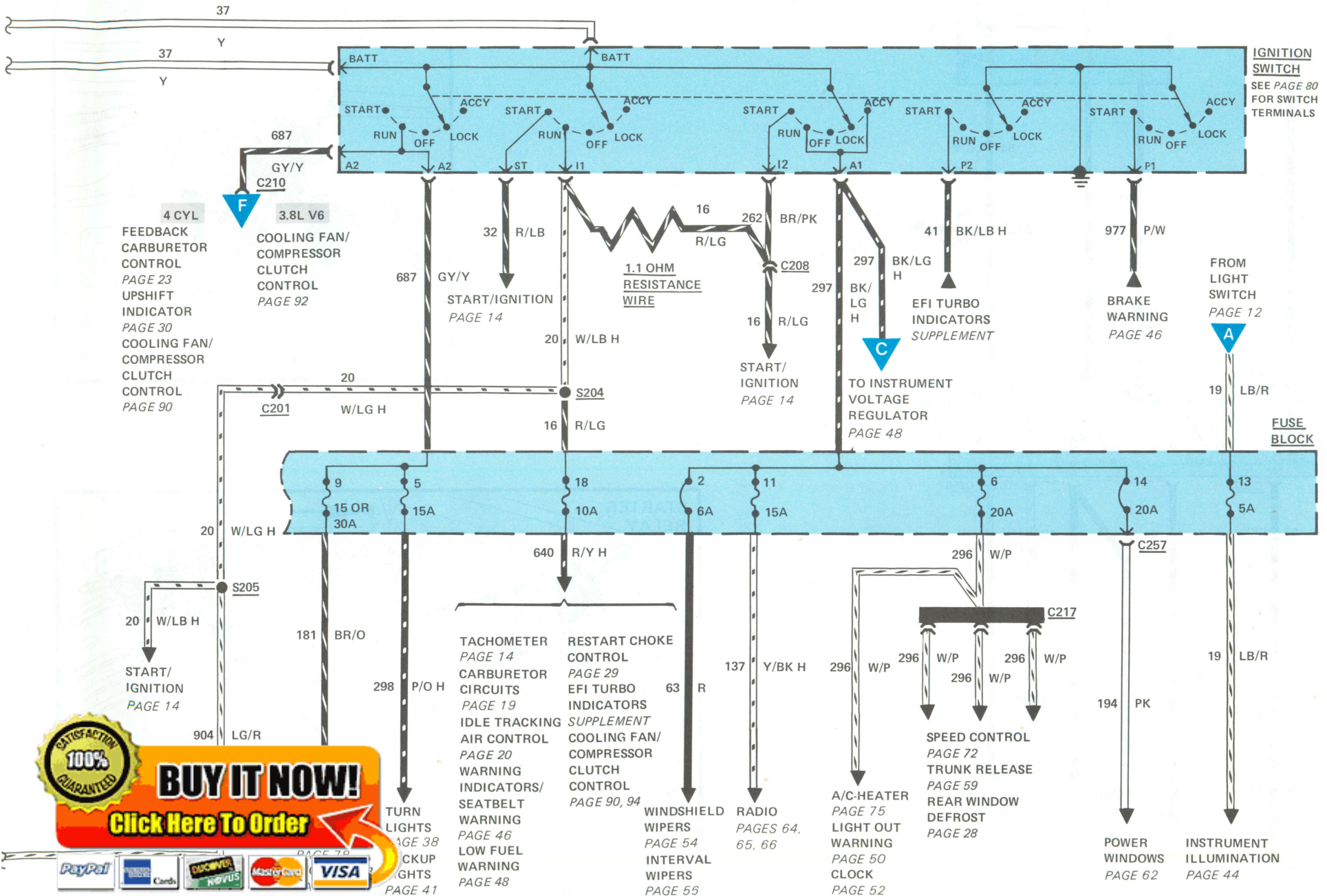

BUY IT NOW!

Click Here To Order



12 CHARGE/POWER DISTRIBUTION (LIGHT SWITCH)

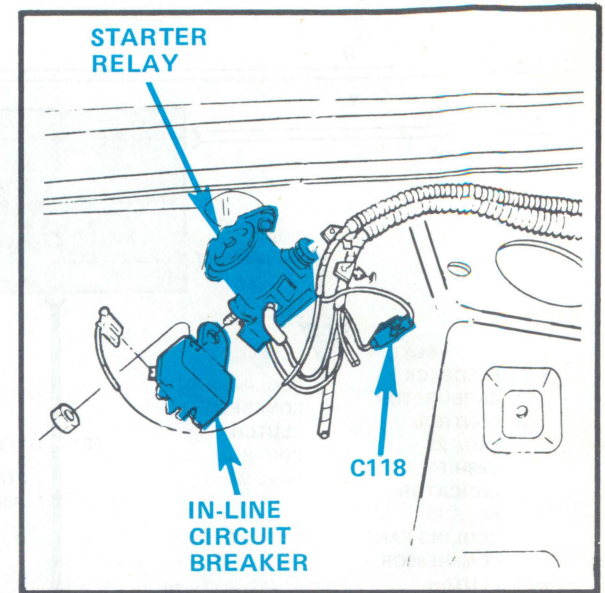
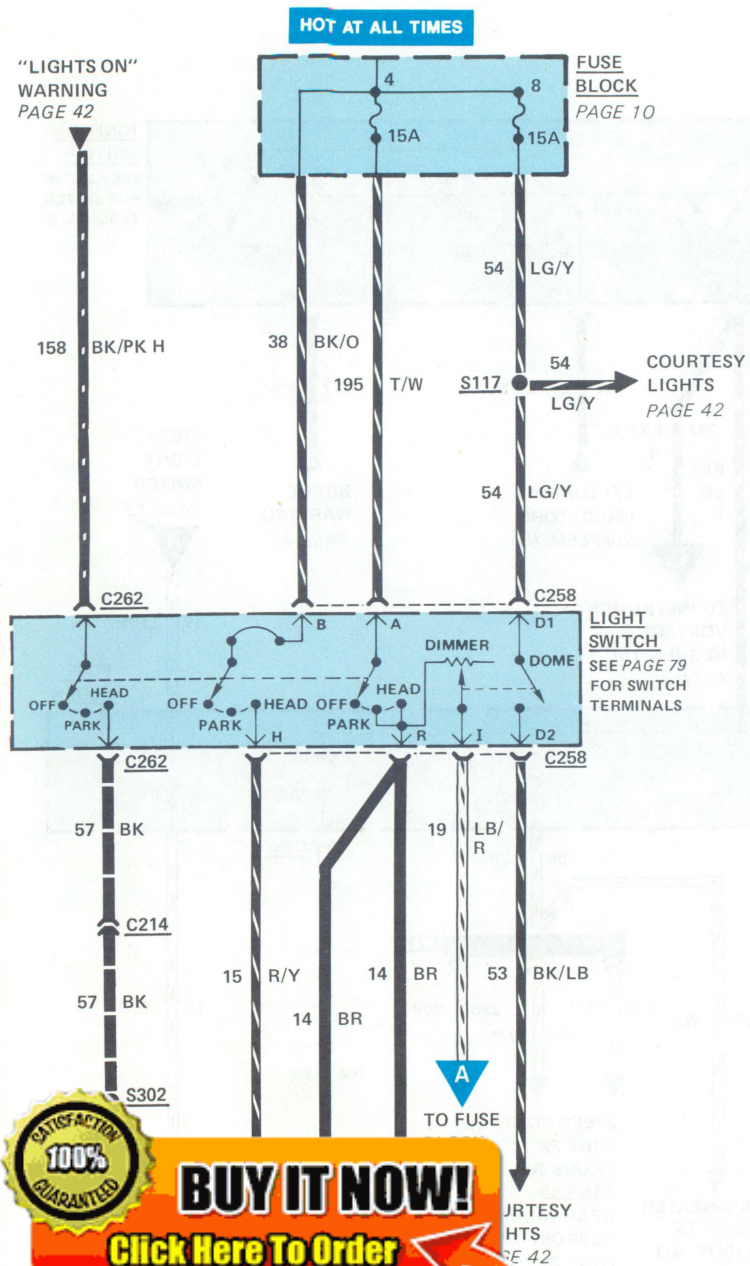

Figure 1 - RH Fender

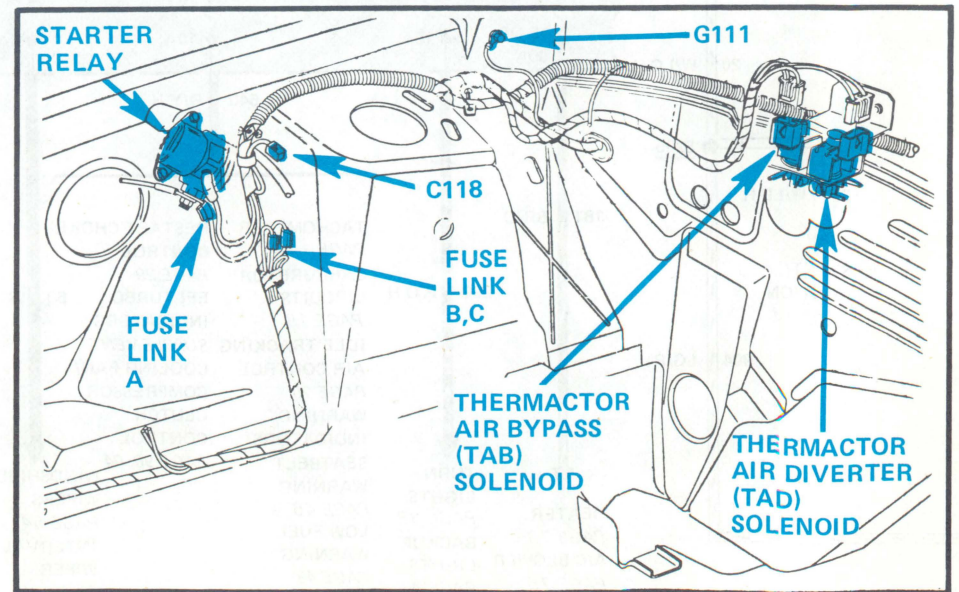

Figure 2 - RH Front Fender

100% SATISFACTION GUARANTEED

BUY IT NOW!

Click Here To Order

PayPal American Express Discover Novus MasterCard VISA

CHARGE

HOW THE CIRCUIT WORKS

The **Battery**, **Alternator**, and **Voltage Regulator** make up the **Charging System**.

With the **Ignition Switch** in **RUN**, **Battery** current flows through the solid-state **Electronic Control** of the **Voltage Regulator**. The **Electronic Control** operates the solid-state field switch which applies **Battery** voltage to the **Alternator** field through terminal F.

With current in the field and the rotor turning, the **Alternator** stator produces a DC voltage at terminal B (to **Battery**). This voltage balances the **Battery** voltage. If the voltages are different, the resulting current flow is indicated on the **Ammeter**. The **Choke Heater** operates only when the **Alternator** is generating current (through terminal S). Above 60°F, the heater causes a thermostatic spring to pull the choke plates open within 1 to 1.5 minutes. Below 60°F, the heater does not operate and normal choke action occurs.

NOTE

The Voltage Regulator with BLUE printing on the cover is used with Ammeter; RED printing with either Ammeter or Alternator Warning Indicator.

COMPONENT LOCATION

		Page-Figure	Color	Terminals
Alternator (4 cyl)	LH front of engine assembly			
(6 and 8 cyl) ...	RH front of engine assembly			
Ammeter	Part of instrument cluster			
Choke Heater.....	Attached to carburetor	19-1		
Fuse Links A, B, C, D, H, W	Near starter relay assembly	12-2		
Fuse Link J.....	At starter relay.....	61-1		
Fuse Links K & L.....	Near LH shock tower	25-2		
In-Line Circuit Breaker	Attached to starter relay.....	12-1		
Starter Relay	RH fender apron in front of wheel well	12-2		
Voltage Regulator	RH fender apron attached below starter relay			
Connector C104	Near starter relay		BR	2
Connector C118	LH fender apron below starter relay.....	12-2	GY	1
Connector C147	Lower LH frame near shock tower			3
Connector C201	Under LH side of I/P on shake brace.....	52-2	GY	8
Connector C208	Under LH side of I/P on shake brace.....	52-2	GY	4
Connector C210	Under LH side of I/P on shake brace.....	52-2	BR	6
Connector C214	Clipped to LH I/P support brace.....	45-3	GY	4
Connector C217	Behind LH side of I/P above fuse block	52-1	Y	3
Connector C247	Behind LH side of I/P on instrument cluster	89-1	GY	14
Connector C258	Behind LH side of I/P attached to light switch	45-2	GY	7
Ground G101	Lower LH front of engine assembly	13-1		
Ground G116	Inside RH fender behind battery	13-1		
Ground G201	Behind LH side of glove box	45-1		

TROUBLESHOOTING HINTS

IMPROPER CHARGING

The most common charge system complaints are dead **Battery**, and **Ammeter** discharging at normal speed.

- Check **Fuse Link A** at **Starter Relay**.
- Check **Alternator** belt tension.
- Check **Battery** terminals and cable clamps.
- Check for clean and tight connections on **Alternator**, **Regulator**, and **Starter Relay**.

Read "Charging System Diagnosis" in Section 31-01 of Shop Manual for detailed **Charging System** tests.

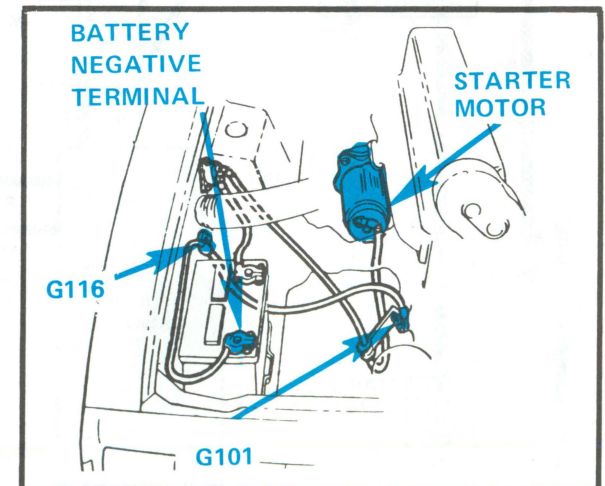

Figure 1 - RH Fender

100% SATISFACTION GUARANTEED

BUY IT NOW!

Click Here To Order

HOT AT ALL TIMES

FUSE LINK C
16 GA BLACK
PAGE 10

HOT IN START OR RUN

FUSE BLOCK
10A
PAGE 11

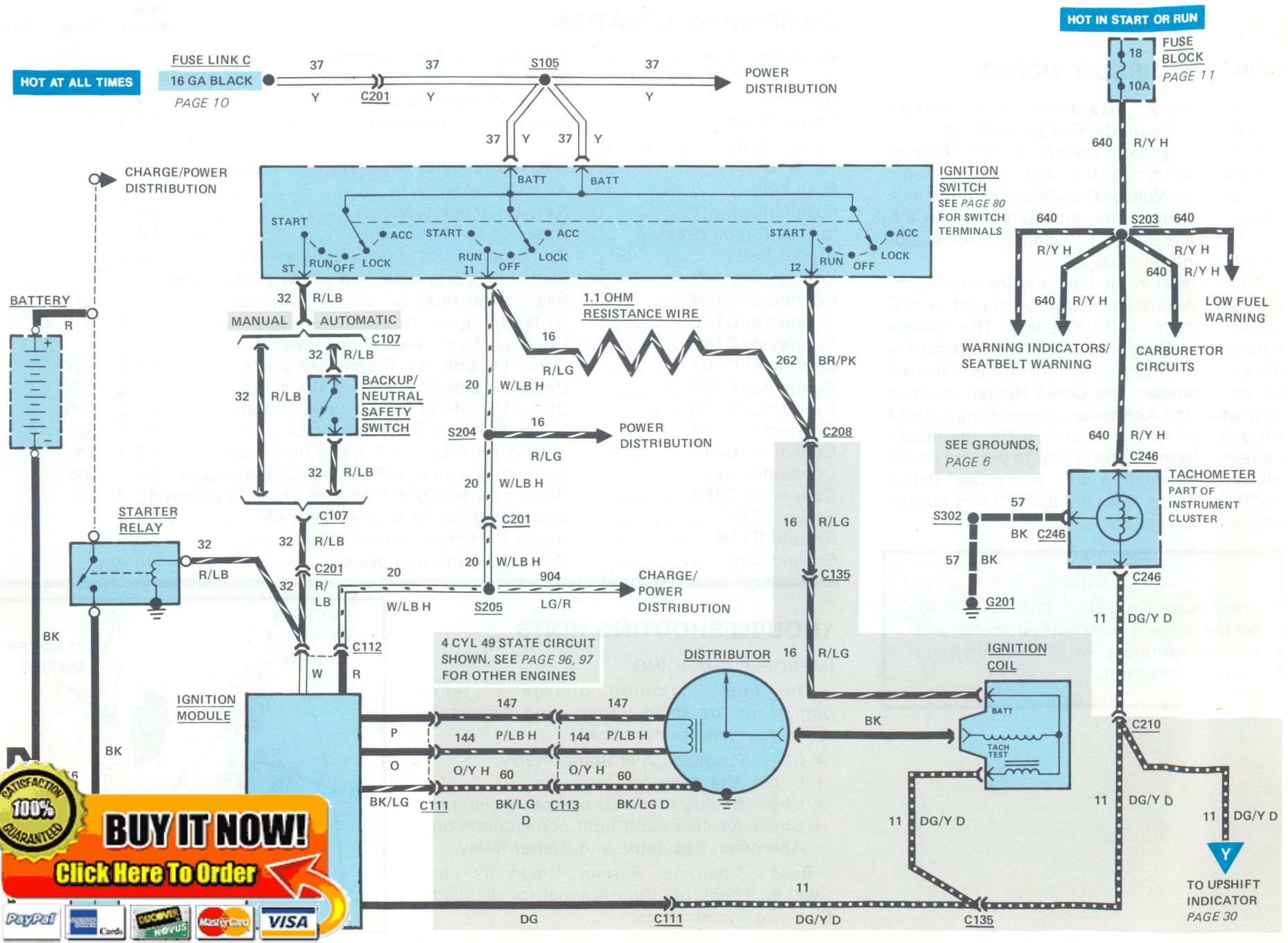

BUY IT NOW!

Click Here To Order



TO UPSHIFT INDICATOR
PAGE 30



**WE SUPPORT VOLUNTARY
MECHANIC CERTIFICATION**



**Ford Parts and Service Division
Training and Publications Department**

INDEX

Compressor Clutch Control	14s
Cooling Fan Control	14s
EFI Turbo Indicators	12s
Electronic Engine Control	6s
Grounds	2s
Ignition	4s
Start	4s

HOW TO USE THIS MANUAL SUPPLEMENT

This supplement covers the electrical circuits of the 2.3L EFI Turbo engine for the 1983 Mustang/Capri. It's intended to be used with the 1983 Mustang/Capri Electrical and Vacuum Troubleshooting Manual (EVTM) (Book Code 0333-503-83).

The circuits described in this supplement are only those that are different because of the EFI Turbo engine. The 1983 Mustang/Capri EVTM shows other circuits (such as headlights) which are the same for all engines for these vehicles.

Refer to the 1983 Mustang/Capri EVTM (Book Code 0333-503-83) for instructions on how to find electrical and vacuum problems, and for instructions of how to use the EVTM.

The index on this page, the schematic diagrams, and the component location charts refer to pages with and without the letter "s". Page references without "s" refer to the 1983 Mustang/Capri EVTM. Page reference with "s" refer to pages in this supplement.

For example:

FUSE Refers to page 11 of the
BLOCK 1983 Mustang/Capri EVTM
PAGE 11

COOLING Refer to page 14s of
FAN this supplement
PAGE 14s

IMPORTANT SAFETY NOTICE

Appropriate service methods and proper repair procedures are essential for the safe, reliable operation of all motor vehicles, as well as the personal safety of the individual doing the work. This Manual provides general directions for accomplishing service and repair work with tested, effective techniques. Following them will help assure reliability.

There are numerous variations in procedures, techniques, tools, and parts for servicing vehicles, as well as in the skill of the individual doing the work. This Manual cannot possibly anticipate all such variations and provide advice or cautions as to each. Accordingly, anyone who departs from the instructions provided in this Manual must first establish that he compromises neither his personal safety nor the vehicle integrity by his choice of methods, tools or parts.

**SATISFACTION
100%
GUARANTEED**

BUY IT NOW!
Click Here To Order

PayPal American Express Discover MasterCard VISA

LH FRONT LIGHTS GROUND

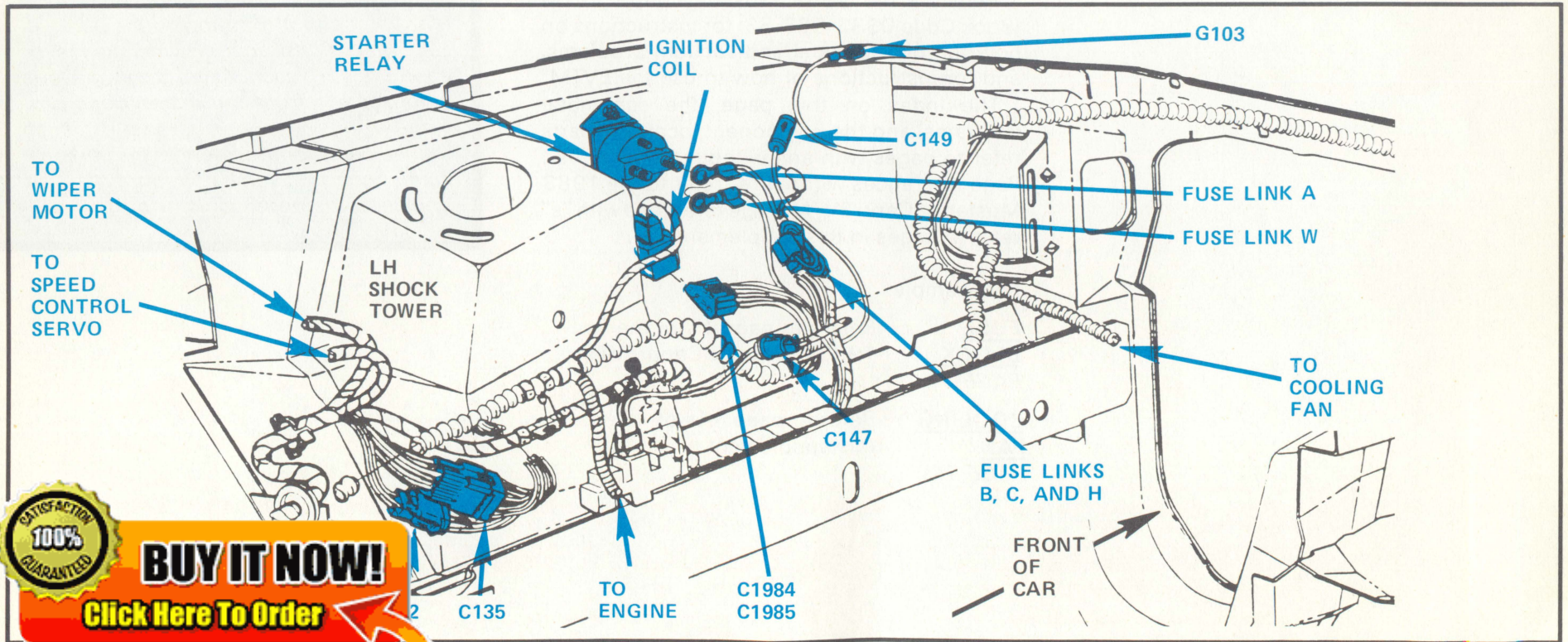
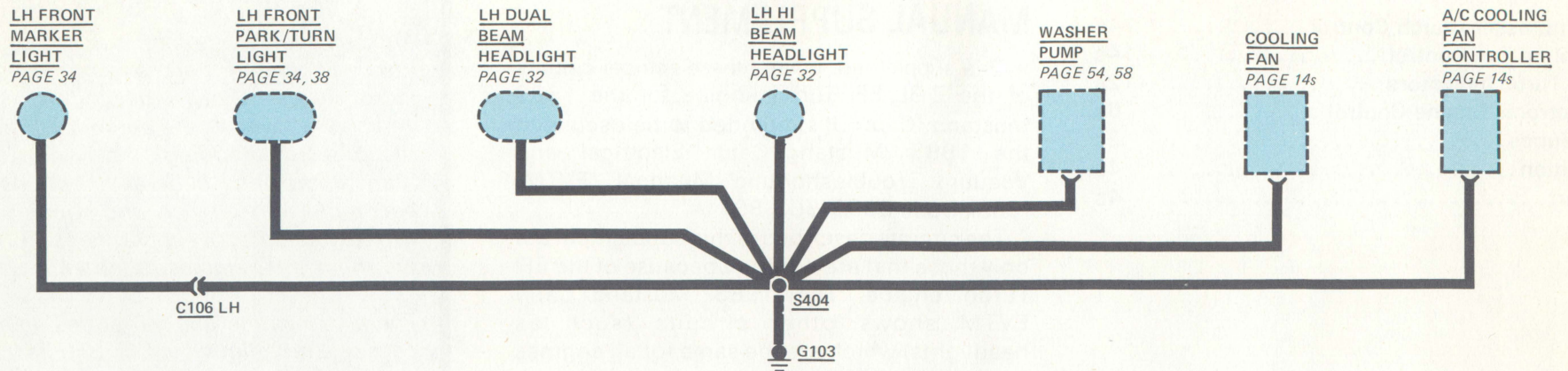

100% SATISFACTION GUARANTEED

BUY IT NOW!

Click Here To Order

PayPal, American Express, Discover, MasterCard, VISA

Figure 1 - LH Fender Apron

REAR LIGHTS GROUND

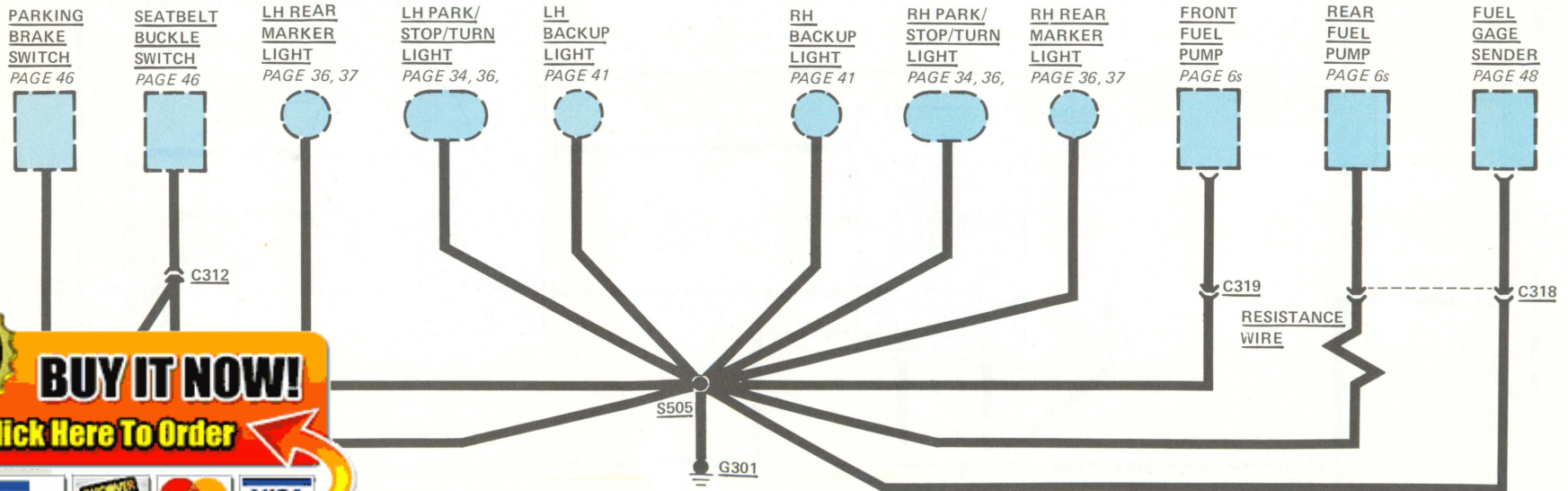
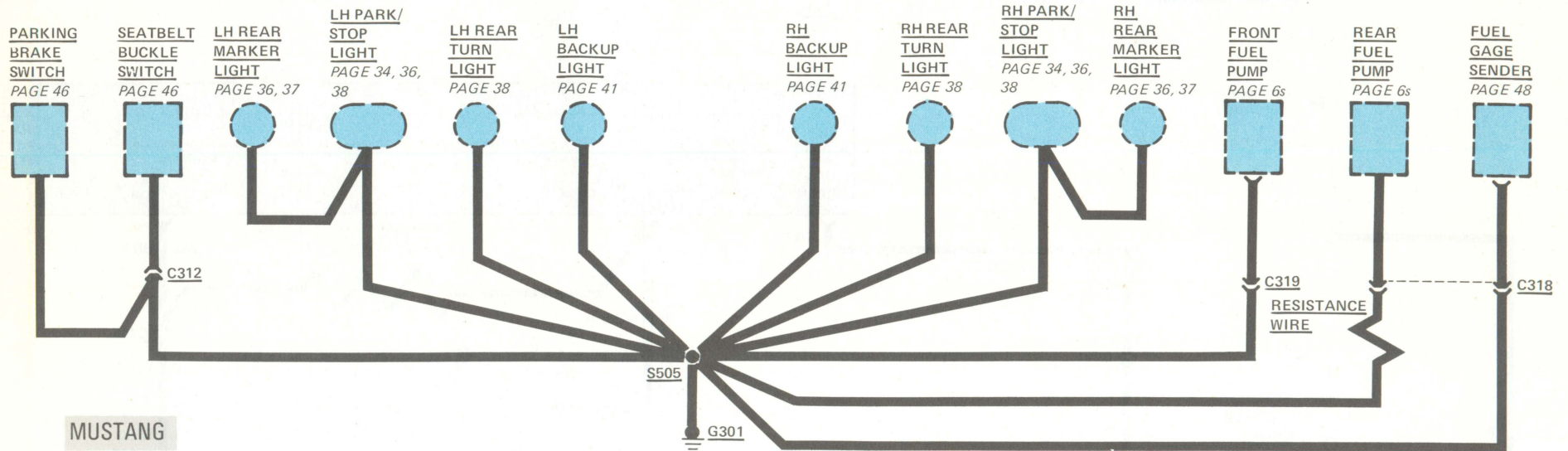

100% SATISFACTION GUARANTEED

BUY IT NOW!

Click Here To Order

PayPal

MasterCard

VISA

START

HOW THE CIRCUIT WORKS

The **Battery**, **Starter Motor**, **Starter Relay**, and **Ignition Switch** make up the **Starting System**.

Turning the **Ignition Switch** to **START** sends current through the **Starter Relay** coil and operates the relay. Current from the **Battery** then flows directly through the **Starter Relay** to the **Starter Motor** to start the engine.

When the **Ignition Switch** is in **START**, battery voltage is applied to both the **START** (circuit 32) and **RUN** (circuit 16) terminals of **Thick Film Integrated Design Ignition (TFI) Module**. When the Ignition Switch is related to the **RUN** position, the voltage on circuit 32 drops to zero.

TROUBLESHOOTING HINTS

(Refer to page 15 of the EVTM.)

IGNITION

HOW THE CIRCUIT WORKS

The EFI Turbo Ignition system contains **Thick Film Integrated Design Ignition (TFI) Module**, which is mounted on the side of the **Distributor**.

When the engine is running:

- The pickup in the **Distributor** provides the signal input through the **TFI Module** to the **Electronic Control Assembly**, which returns a signal to the **TFI Module**.

The **TFI Module** switches current on and the primary circuit of the Ignition pulses. current produce of up to

COMPONENT LOCATION

		Page-Figure	Color	Terminals
Electronic Control Assembly (ECA)	Under RH front seat.....	17s-1		
Fuse Link C	At starter relay assembly	2s-1		
Ignition Coil	Near front of LH front shock tower.....	2s-1		
Starter Relay	LH front fender	2s-1		
TFI Ignition Module	Connected to side of distributor	11s-1		
Connector C107	Attached to LH side of transmission support.....	22-4	BR	4
Connector C112	LH fender apron	2s-1	BK	3
Connector C135	LH fender apron	2s-1	GY	8
Connector C149	Near battery	2s-1		1
Connector C201	Under LH side of I/P on shake brace.....	52-2	GY	8
Connector C208	Under LH side of I/P on shake brace.....	52-2	GY	4
Connector C210	Under LH side of I/P shake brace.....	52-2	BR	6
Connector C275.....	LH side of engine		N	2
Ground G101	Lower LH front of engine	18s-2		
Ground G122	Inside LH fender behind battery	18s-3		

- High voltage pulses are transmitted to the **Distributor**, which sends them to fire the spark plugs.

Two signal lines (circuits 324 and 329) plus a ground line (circuit 60) are connected between the **Electronic Control Module** and the **TFI Ignition Module**.

- If the engine operates with a fixed 10° BTDC spark timing and the EGR system does not operate, the EEC System is operating in its fail-safe mode which indicates a problem in the EEC System.

TROUBLESHOOTING HINTS

EEC SYSTEM

- Because of the complexity of this system, special test equipment is required to diagnose it effectively. See the Shop Manual for details of testing.
- In general—
- If there is **NO SPARK** at the spark plugs, check the primary circuit from the Ignition Switch through the Ignition Coil and Ignition Module to ground.
- Check **Battery** for state of charge and for clean, tight battery terminal connections.

100% SATISFACTION GUARANTEED

BUY IT NOW!

Click Here To Order

PayPal Discover MasterCard VISA



WE SUPPORT VOLUNTARY MECHANIC CERTIFICATION



Ford Parts and Service Division
Training and Publications Department

100% SATISFACTION GUARANTEED

BUY IT NOW!

Click Here To Order 