

1979 MUSTANG-CAPRI



Click Here To Order

BUY IT NOW!

DEMO

This DEMO contains only a few pages of the entire manual/product.

Not all Bookmarks work on the Demo, but they do on the full version.

Features:

- Searchable text
- Printable pages
- Bookmarked for easy navigation
- High Resolution images
- Zoom to see exact details
- Money back Guarantee
- Available on USB and eBook download

ELECTRICAL & VACUUM TROUBLE- SHOOTING MANUAL

1979 MUSTANG CAPRI



License #84356800

Copyright © 2023, Forel Publishing Company, LLC, Woodbridge, Virginia

All Rights Reserved. No part of this book may be used or reproduced in any manner whatsoever without written permission of Forel Publishing Company, LLC. For information write to Forel Publishing Company, LLC, Woodbridge, VA 22192

**1979 Mustang / Capri Electrical & Vacuum Trouble-
Shooting Manual (EVTM)
EAN: 978-1-60371-420-4
ISBN: 1-60371-420-0**

Forel Publishing Company, LLC
Woodbridge, VA 22192
Email: sales@ForelPublishing.com
<https://www.ForelPublishing.com>



This publication contains material that is reproduced and distributed under a license from Ford Motor Company. No further reproduction or distribution of the Ford Motor Company material is allowed without the express written permission of Ford Motor Company.

Note from the Publisher

This product was created from the original Ford Motor Company's publication. Every effort has been made to use the original scanned images, however, due to the condition of the material; some pages have been modified to remove imperfections.

Disclaimer

Although every effort was made to ensure the accuracy of this book, no representations or warranties of any kind are made concerning the accuracy, completeness or suitability of the information, either expressed or implied. As a result, the information contained within this book should be used as general information only. The author and Forel Publishing Company, LLC shall have neither liability nor responsibility to any person or entity with respect to any loss or damage caused, or alleged to be caused, directly or indirectly by the information contained in this book. Further, the publisher and author are not engaged in rendering legal or other professional services. If legal, mechanical, electrical, or other expert assistance is required, the professional should be sought.



	Text Page	Wiring Diagram Page		Text Page	Wiring Diagram Page
A/C-Heat	39, 40	38, 39	Lights (continued)		
Back of the Instrument Panel	9	—	Hazard	15	14
Carburetor Circuits	—	22	Headlights	12	12
Charge	5	6	Indicators		
Cigar Lighter	20	20	Brake	22	22
Clock	—	18, 19, 20, 39	Low Fuel	23	23
Electrical Symbols	IFC	—	Turbo Boost	21	21
Engine Views	4	—	Instrument Illumination	19	19
Fuel Gage	23	23	Stop	15	14
Fuse Block Information	6	7	Turn	15	14
Grounds	3	3	Liftgate Wiper/Washer	30	30
Heater	33	33	“Light Out” Warning	16	16
Horn	20	20	Power Bus Information	8	—
How to Find the Electrical Problem	2	—	Power Distribution	8	7
How to Find the Vacuum Problem	35	—	Power Door Locks (2 and 4 DR)	32	32
Ignition	11	10	Radio (Premium Sound)	26	26
Interval Wiper/Washer	29	28	Radio (Mono/CB)	25, 26	24
Key Warning	—	18	Radio (Stereo/CB)	24, 25	25
Liftgate Wiper/Washer	30	30	Rear Window Deice	31	31
Lights			Seatbelt Warning	22	22
Backup	17	17	Speed Control	37	36
Courtesy	18	18	Start	11	10
Dome	—	18	Tachometer	—	10
Exterior	12	13	Trunk Release	30	30
Glove Box	—	18	Vacuum Distribution	—	34
			Vacuum Symbols	IBC	—
			Wiper/Washer	27	27

ELECTRICAL SYMBOLS

NOTE
ALL SWITCHES SHOWN IN THIS MANUAL ARE IN CAR "AT REST" POSITION, WITH ENGINE JUST TURNED OFF.

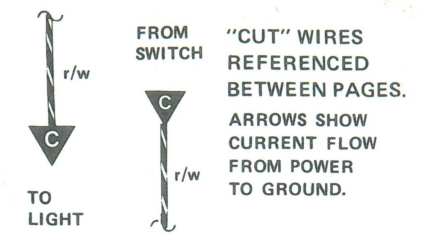
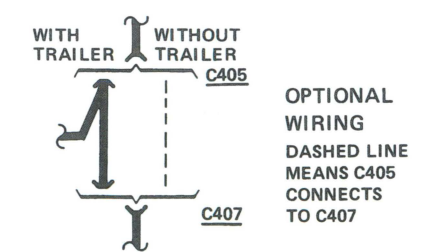
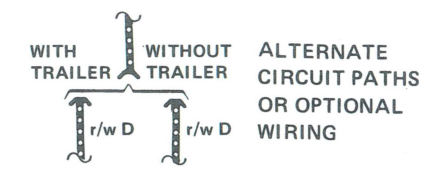
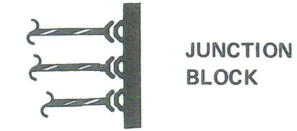
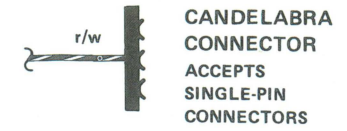
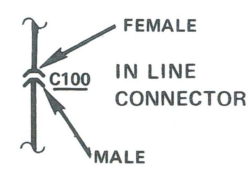
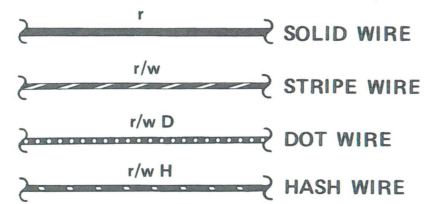
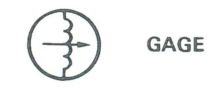
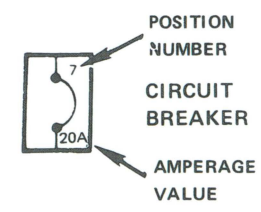
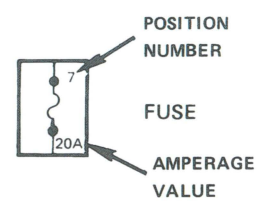
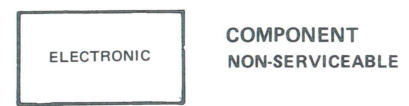
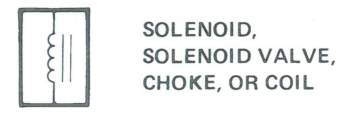
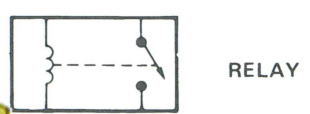
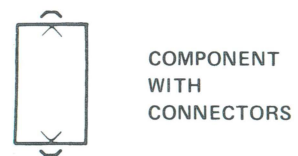
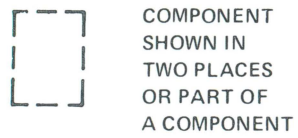

IMPORTANT INFORMATION, AND CAR AND MECHANIC SAFETY NOTES APPEAR IN BOXES ON TEXT PAGES. THERE ARE THREE KINDS:

NOTE
Additional information.

CAUTION
Possible damage to vehicle or equipment.

WARNING
Possible injury to mechanic.

100% SATISFACTION GUARANTEED

BUY IT NOW!

Click Here To Order

TROUBLESHOOTING STEPS

1. Check the complaint. Operate circuit yourself to find out what's not working. Don't waste time troubleshooting part of the problem.
2. Read **How The Circuit Works** and study the wiring diagram.
3. Find the fault. Read **Troubleshooting Hints** and see if any hint fits your problem. The **Component Location Chart** lists where the components and connectors are found.
4. Make the repair.
5. Test the repair. Try the system in all modes to be sure the *whole* problem is fixed.

TROUBLESHOOTING TOOLS

TEST LIGHT

A test light is a 12-volt bulb with two test leads (Figure 1).

Uses: Voltage Check, Short Check

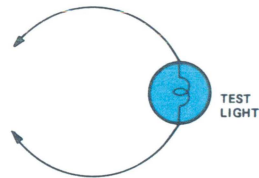

Figure 1 – Test Light

SELF-POWERED TEST LIGHT

The self-powered test light is a light, battery, and set of test leads wired in series (Figure 2). When connected to two points of a continuous circuit, the light glows.

CAUTION

Be sure power is off in circuit during testing.

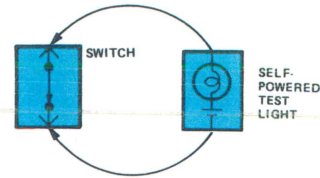

Figure 2 – Self-Powered Test Light

JUMPER WIRE

This is a length of wire with clips, used to connect two points of a circuit. A jumper wire can complete a circuit by bypassing an open.

WARNING

Never use a jumper wire across high-resistance loads (motors, etc.) connected between hot and ground. This direct battery short may cause injury or fire.

Uses: Bypassing Switches or Open Circuits

VOLTMETER (Rotunda 02-0204 Circuit Tester or equivalent)

A DC voltmeter measures circuit voltage. Connect negative (– or black) lead to ground, and positive (+ or red) lead to voltage measuring point.

OHMMETER

An ohmmeter shows the resistance between two connected points. IT SHOULD ONLY BE USED ON DE-ENERGIZED CIRCUITS. Hot circuits can cause meter damage and false readings.

BASIC TROUBLESHOOTING

Voltage Check:

Connect one lead of test light to a known good ground, or the negative (–) battery terminal. Test for voltage by touching the other lead to the test point. Bulb lights when the test point has voltage.

Short Check (short to ground):

A blown fuse is usually caused by a short to ground in that circuit. Check as follows:

- 1) Turn off everything powered through the fuse.
- 2) Disconnect all loads powered through the fuse.
 - motors: disconnect motor connector
 - lights: remove bulbs
- 3) Turn ignition switch to RUN (if necessary) to power fuse.
- 4) Connect one test light lead to hot end of blown fuse. Connect other lead to ground. Light should glow showing power to fuse.

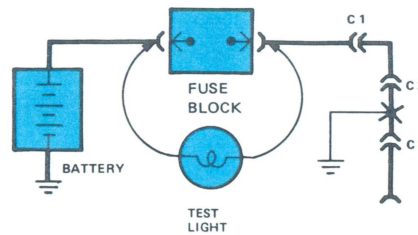

Figure 3 – Short Check

- 5) Disconnect ground lead and connect to load side of fuse.
 - a) Test light OFF: the short is in the disconnected equipment.
 - b) Test light ON: short is in wiring. Find short by disconnecting circuit connectors one at a time. In the example (Figure 3) with a ground at X,

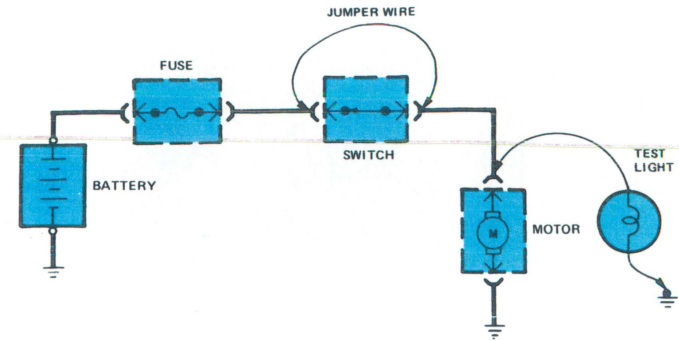

Figure 4 – Switch Circuit Check and Voltage Check

the light goes out when C1 or C2 is disconnected, but stays on after disconnecting C3. This means the ground is between C2 and C3.

Continuity Check:

CAUTION

Be sure power is off in circuit during testing.

(Locating open circuits) Connect one lead of self-powered test light or ohmmeter to each end of circuit (Figure 2). Light will glow if circuit is closed. Switches and fuses can be checked in the same way.

“Good Ground” Check:

Turn on power to circuit. Perform Voltage Check between suspected bad ground and frame. Any voltage means ground is bad.

Turn off power to circuit. Connect one lead of self-powered test light or ohmmeter to wire in question, and the other to known ground. If light glows, circuit ground is ok.

Switch Circuit Check:

In an inoperative circuit with a switch in series with the load, jumper the terminals of

the switch to power the load. If jumping the terminals powers the circuit, the switch is bad (Figure 4).

This test also finds an open in part of a circuit.

GENERAL TROUBLESHOOTING HINTS

If several unrelated circuits fail at the same time, chances are the power (fuse) or ground circuit is bad.

Use the **Fuse Block/Power Bus Information** to find what circuits are powered through each fuse.

Use the **Ground Pages** to find which circuits have a common ground. 40% of all car electrical problems are grounding faults.

NOTE

Ground pages show only complex eyelet grounds. Circuits with single or component grounds are shown on circuit diagram page.

100% SATISFACTION GUARANTEED

BUY IT NOW!

Click Here To Order

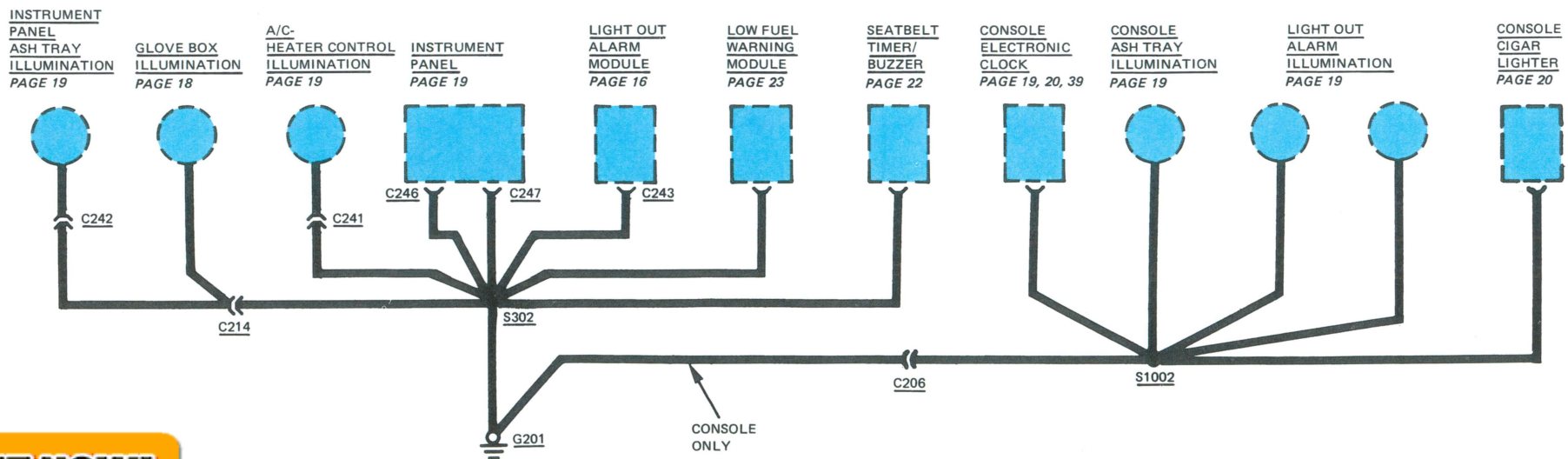
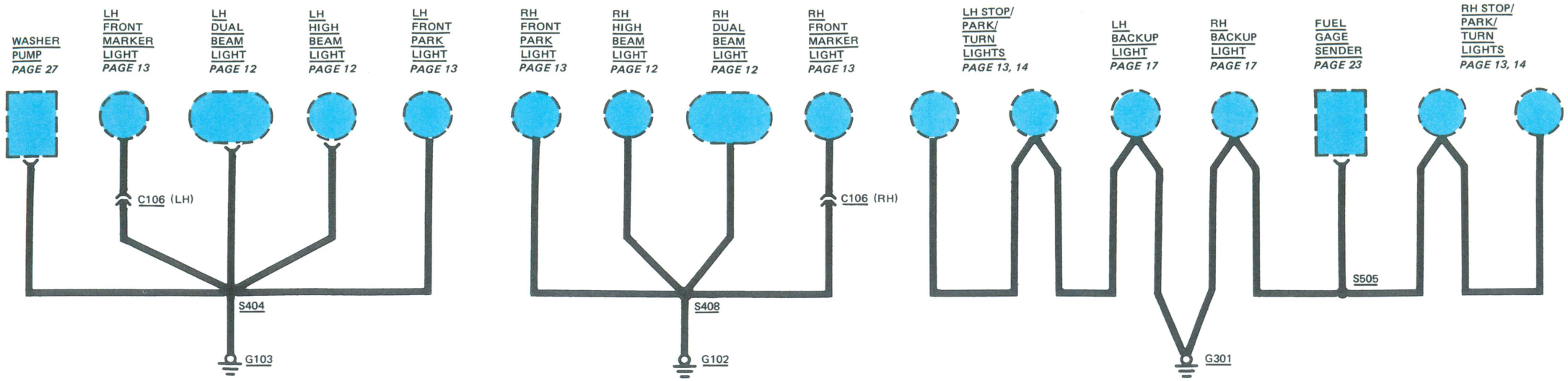

100% SATISFACTION GUARANTEED

BUY IT NOW!

Click Here To Order

4 ENGINE VIEWS

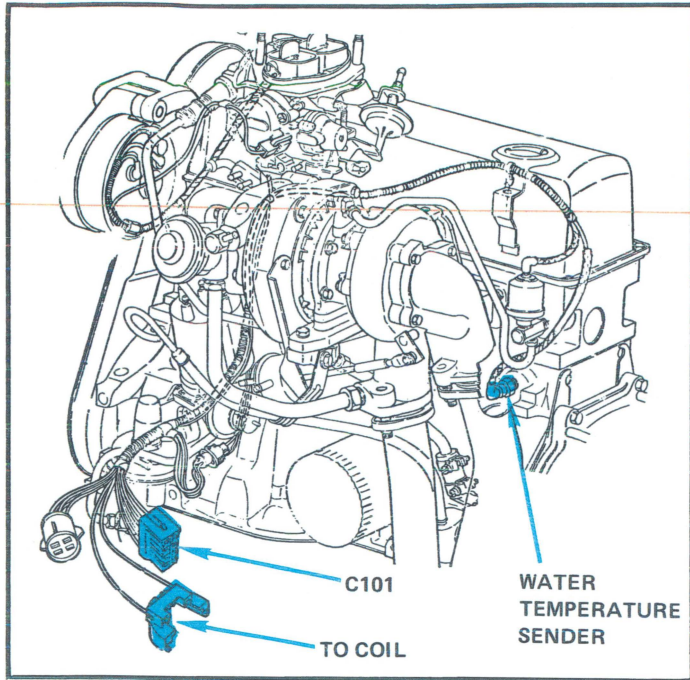

Figure 1 – 4 Cylinder With Turbocharger

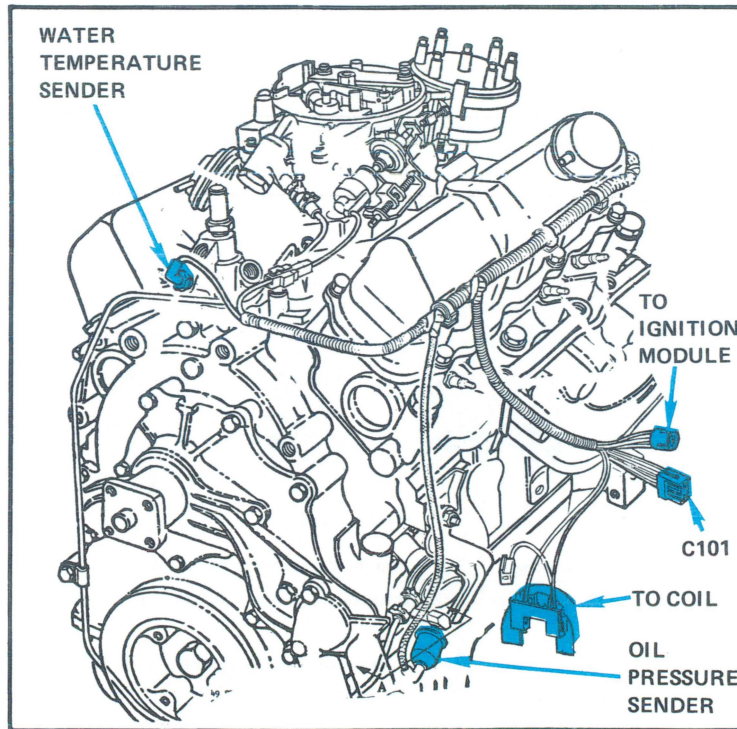

Figure 2 – 6 Cylinder

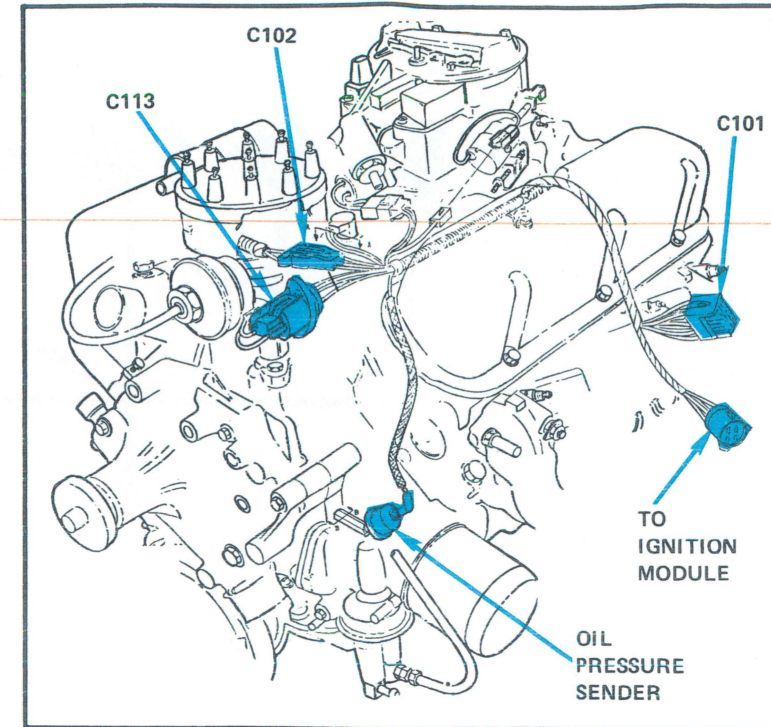

Figure 3 – 8 Cylinder

100% SATISFACTION GUARANTEED

BUY IT NOW!

[Click Here To Order](#)

PayPal American Express Discover MasterCard VISA

HOW THE CIRCUIT WORKS

The **Battery**, **Alternator**, and **Electronic Voltage Regulator** make up the **Charging System**.

With the **Ignition Switch** in **RUN**, **Battery** current flows through the solid-state **Electronic Control** section of the **Electronic Voltage Regulator**. The **Electronic Control** operates the solid-state **Field Switch**, which applies battery voltage to the **Alternator Field** through terminal **F**.

With current in the **Field** and the rotor turning, the **Alternator Stator** produces a DC voltage at terminal **B** (to **Battery**). This voltage balances the **Battery** voltage. If the voltages are different, the resulting current flow is indicated on the **Ammeter**.

TROUBLESHOOTING HINTS

IMPROPER CHARGING

The most common charge system complaints are dead battery, battery using too much water, and alternator warning light on at normal speed.

- Check fuse link at **Starter Relay**.
- Check **Alternator** belt tension.
- Check **Battery** terminals and cable clamps.
- Check for clean and tight connections on **Alternator**, **Regulator**, and **Starter Relay**.

Read "Charging System Diagnosis" in Section 31-01 of Shop Manual for detailed charging system tests.

CAUTION

Do not use a new alternator (4 amp field winding) with an electromechanical regulator.

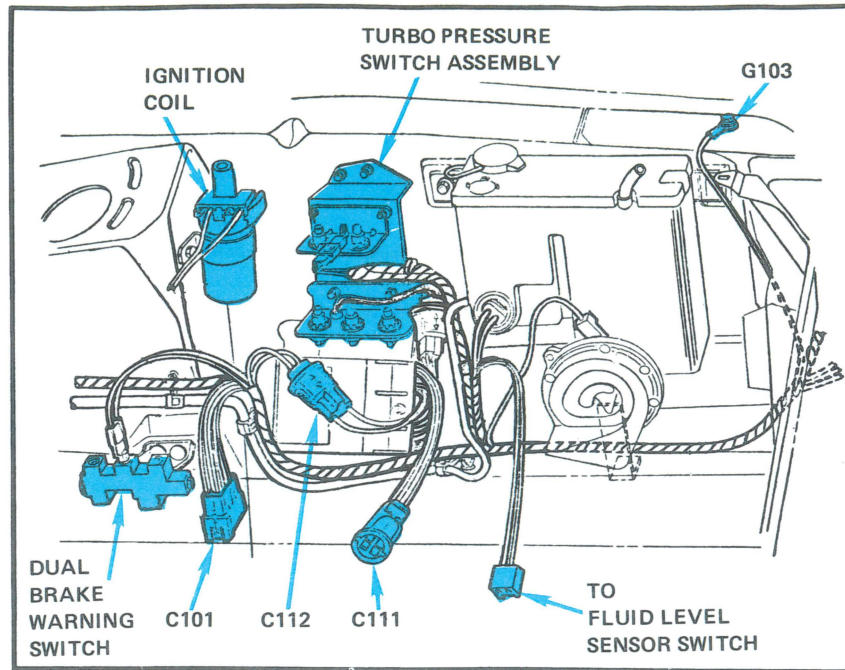

Figure 1 - LH Fender Apron (4 Cylinder)

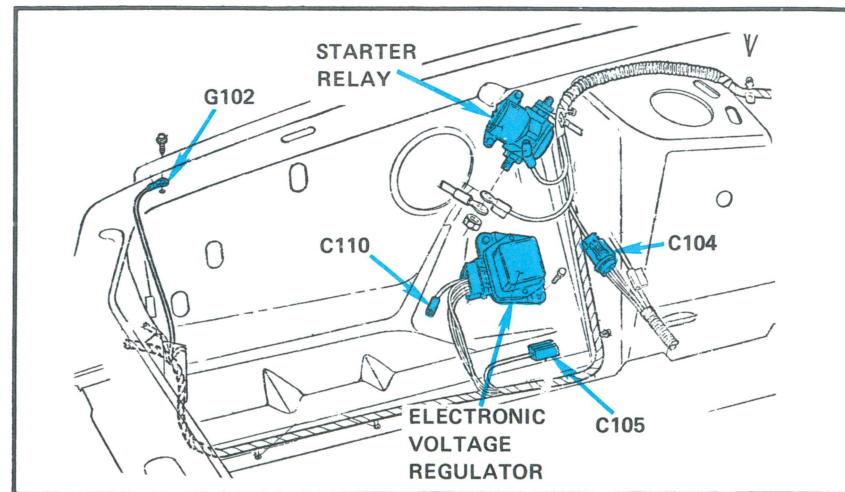







Figure 2 - RH Fender Apron

COMPONENT LOCATION

	Page-Figure	Shape	Color	Terminals
Choke Heater . . .	On engine at choke			
Electronic Voltage Regulator . . .	RH fender apron			5-2
Radio Noise Capacitor	RH fender apron			
Starter Relay	RH fender apron			5-2
Connector C104	RH fender apron		br	3
Connector C201	LH and RH cowl in "A" pillar		-	8
Connector C202	RH cowl in "A" pillar		gy	3
Connector C210	Under instrument panel, near brake pedal		br	
Ground G101	Engine compartment			

100% SATISFACTION GUARANTEED

BUY IT NOW!

Click Here To Order



6 CHARGE / FUSE BLOCK

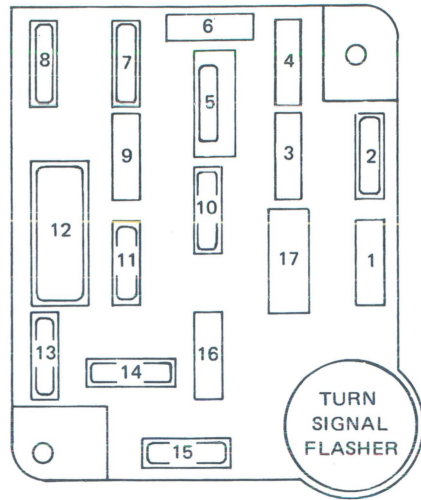

Fuse Position	Amps	Circuits Protected
1	—	Not used
2	10	Carburetor Circuits, Warning Lights, Tachometer, Seatbelt Buzzer, Turbo Boost Indicators
3	—	Not used
4	—	Not used
5	20	Horn, Cigar Lighter, Console Clock
6	—	Not used
7	15	Courtesy Lights, Key Warning, Trunk Light, Glove Box Light, Digital Clock on Clock/Radio
8	20	Hazard Flasher, Stoplight Switch, Speed Control
9	—	Not used
10	15	Radio
11	25	A/C Clutch, Console Clock, Liftgate Wiper/Washer, Speed Control, Deice, Trunk Release
12	6 (ckt bkr)	Windshield Wipers; Interval Wipers, Windshield Washer
13	5	Instrument Illumination
14	15 or 30	15 with Heater Blower; 30 with A/C Blower
15	20	Turn Signals, Backup Lights, Low Fuel Warning, Light Out Warning
	—	Not used

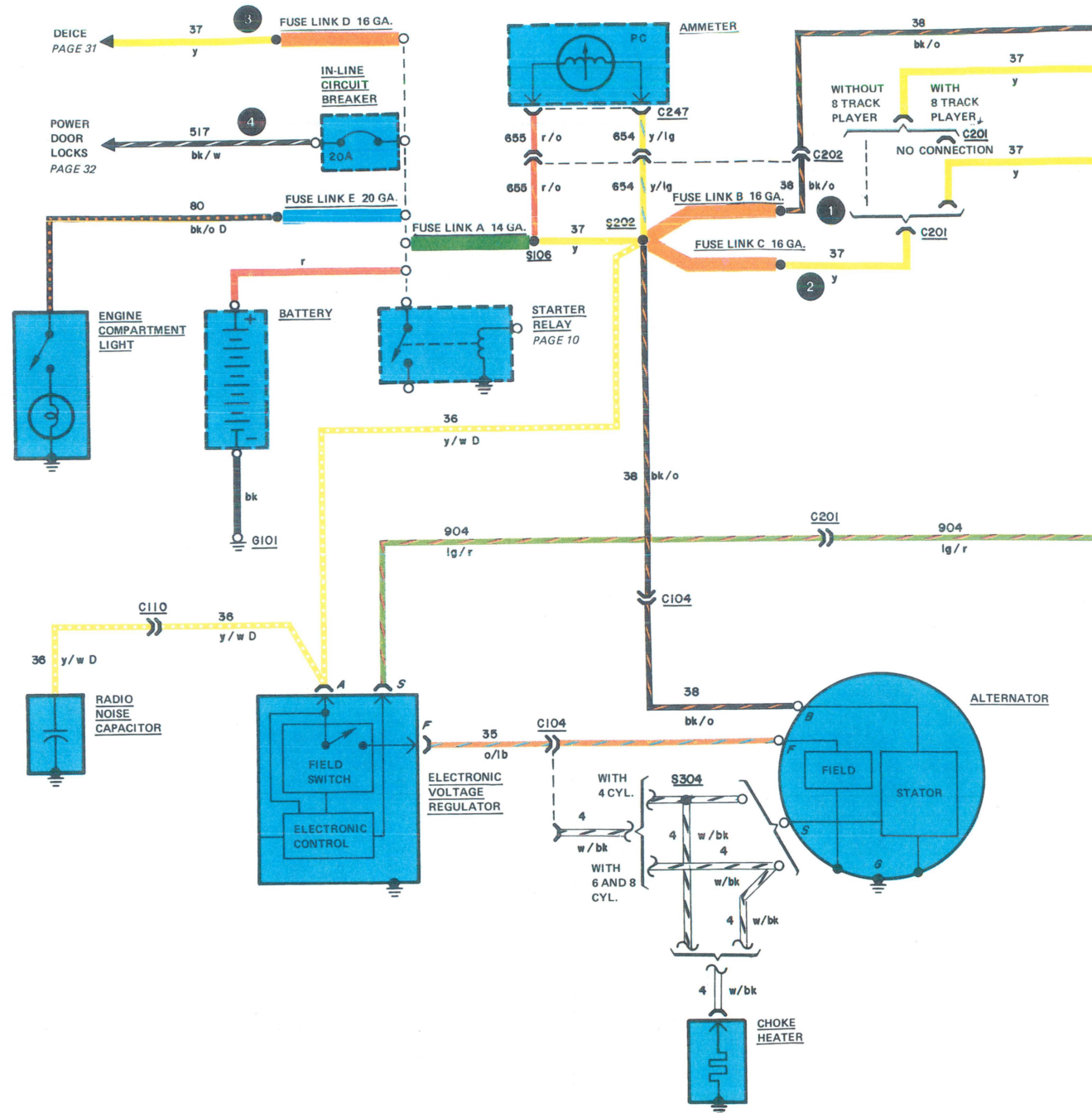

100% SATISFACTION GUARANTEED

BUY IT NOW!

[Click Here To Order](#)

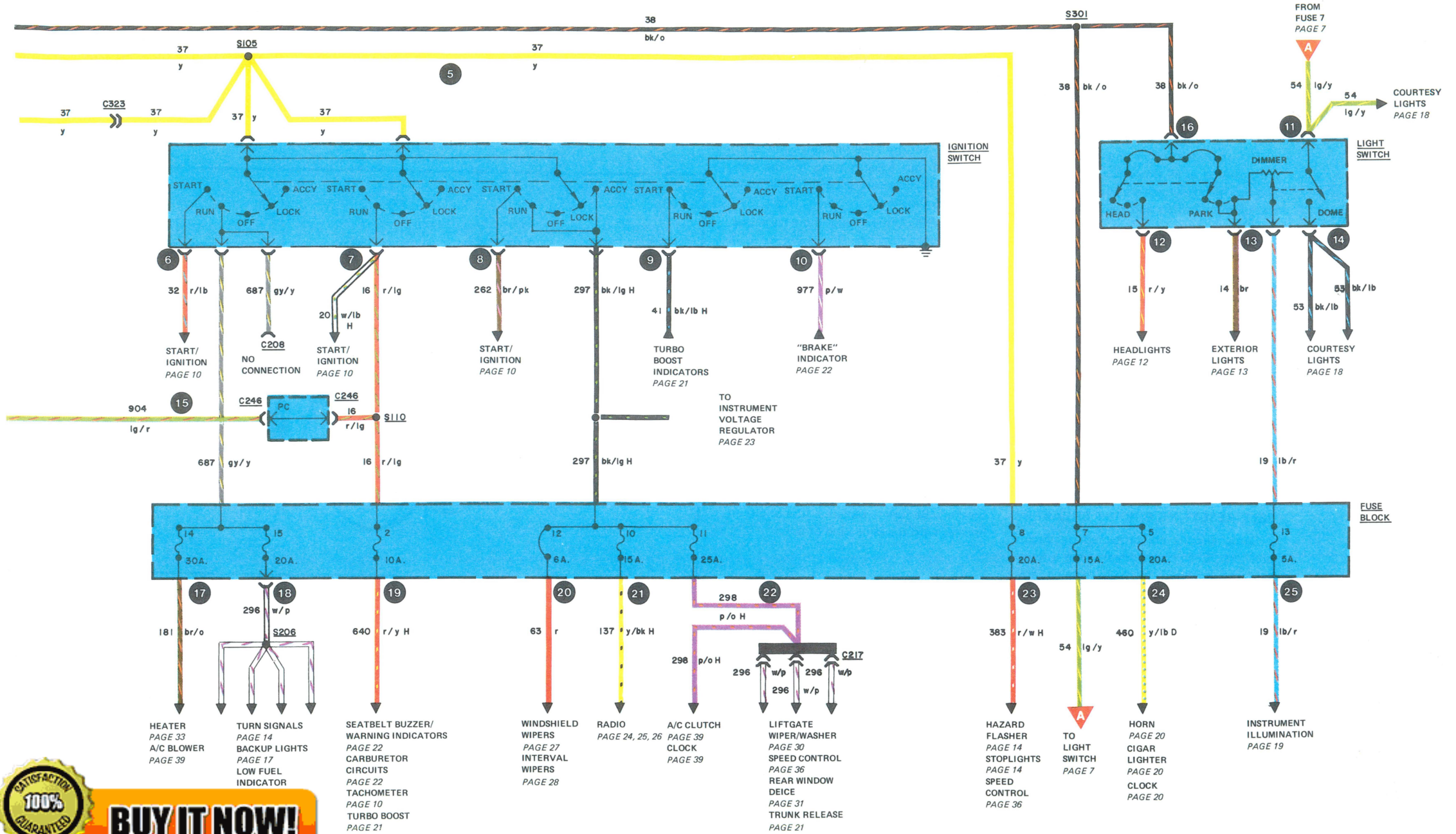

100% SATISFACTION GUARANTEED

BUY IT NOW!

[Click Here To Order](#)

8 POWER BUS / WIRING HARNESS INFORMATION

POWER BUS INFORMATION

The **Alternator** and **Battery** are connected together at the **Starter Relay** hot terminal. Other circuits originate at the **Starter Relay** hot terminal and are protected by fuse links. Low power circuits are also protected by fuses.

The **Ignition Switch** and **Light Switch** are powered at all times as are **Fuses 5, 7, and 8**. The other fuses are powered through the **Ignition Switch** and the **Light Switch**.

FUSE LINK

The **Fuse Link** is a short length of wire smaller than the wire in the protected circuit. The wire is covered with a thick non-flammable insulation. An overload causes the link to heat and the insulation to smoke or blister. If the overload remains, the link will melt, causing an open circuit. The links are color coded for wire size as follows: **Blue - 20 gage, Red - 18 gage, Yellow - 17 gage, Orange - 16 gage, Green - 14 gage.**

When replacing, make tight crimp joints or hot solder joints for good connections.

SELF-RESETTING CIRCUIT BREAKERS

Some circuits are protected by circuit breakers. Each circuit breaker has a set of contacts operated by a bi-metallic arm which carries the breaker current. If the current becomes too high, the heating of the arm causes it to bend and open the contacts.

When the arm cools, it bends straight and re-closes the contacts. This cycle repeats as long as the overcurrent exists, with power applied.

WIRING HARNESS INFORMATION

All wiring between components is routed through wiring harnesses. Each harness is identified by a number, year of

development, car line, harness number, and design level. For example, a harness tagged "D9LB-14401-AE" means "Developed 1979 for the Mark V-14401 harness (main wiring assembly behind the instrument panel) -Model 'A', revision 'E.' "

Figure 1 shows the major harness wiring assemblies for the 1979 Mustang and Capri. The small blue squares stand for the connector (or connectors) which join one harness to the next.

Each "RPO Option" adds more harnesses to the car.

Because the harnesses are bound with a heavy tape, pinpointing a short or open in a single wire of a long harness is almost impossible. If a short or open is traced to a major harness, either the harness must be replaced or the circuit can be jumpered with an added wire.

FUSE BLOCK

The Fuse Block for the 1979 Mustang/Capri is a new design. Fuses are identified by the numbered value in amps, and by a color code. Some positions (5) may have either a fuse with adapter or a circuit breaker. Be sure to replace a fuse or circuit breaker with the same kind of unit.

COMPONENT LOCATION

		Page-Figure	Shape	Color	Terminals
Fuse Block	Under instrument panel, LH cowl	9-1			
Connector C217 . . .	LH side of instrument panel	9-1		-	3
Connector C246 . . .	LH side of instrument cluster	9-1		-	21

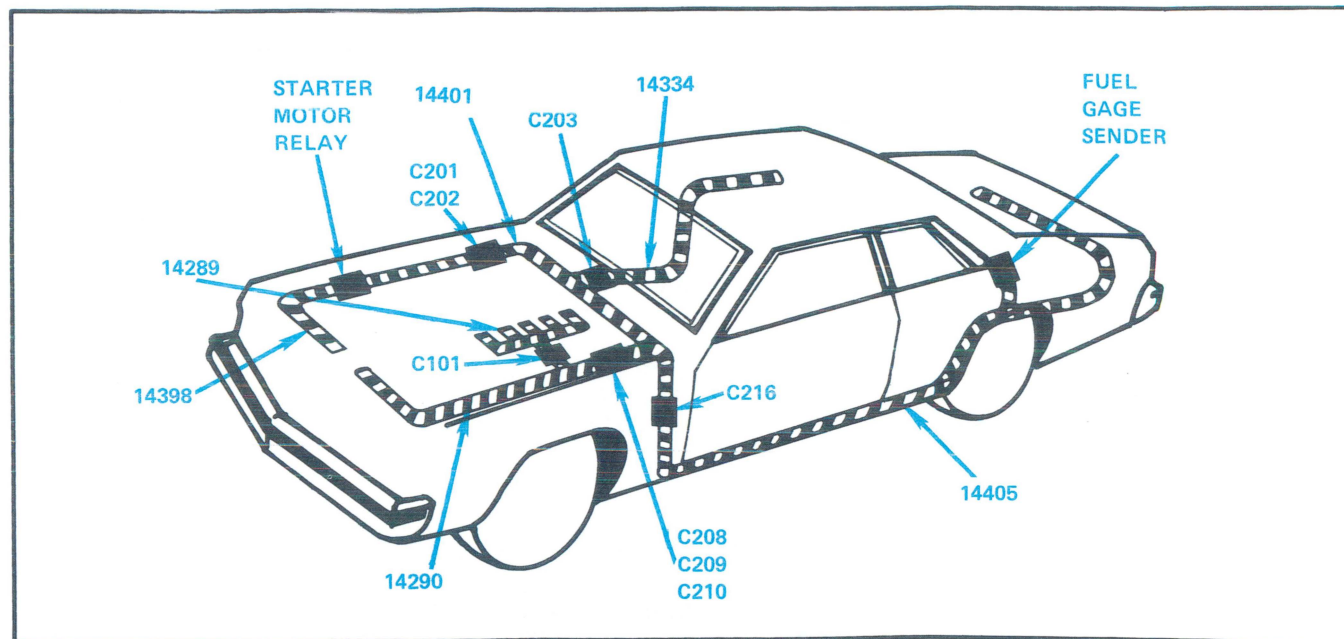

Figure 1 - Main Harness Location

100% SATISFACTION GUARANTEED

BUY IT NOW!

Click Here To Order

PayPal, Discover, American Express, MasterCard, VISA

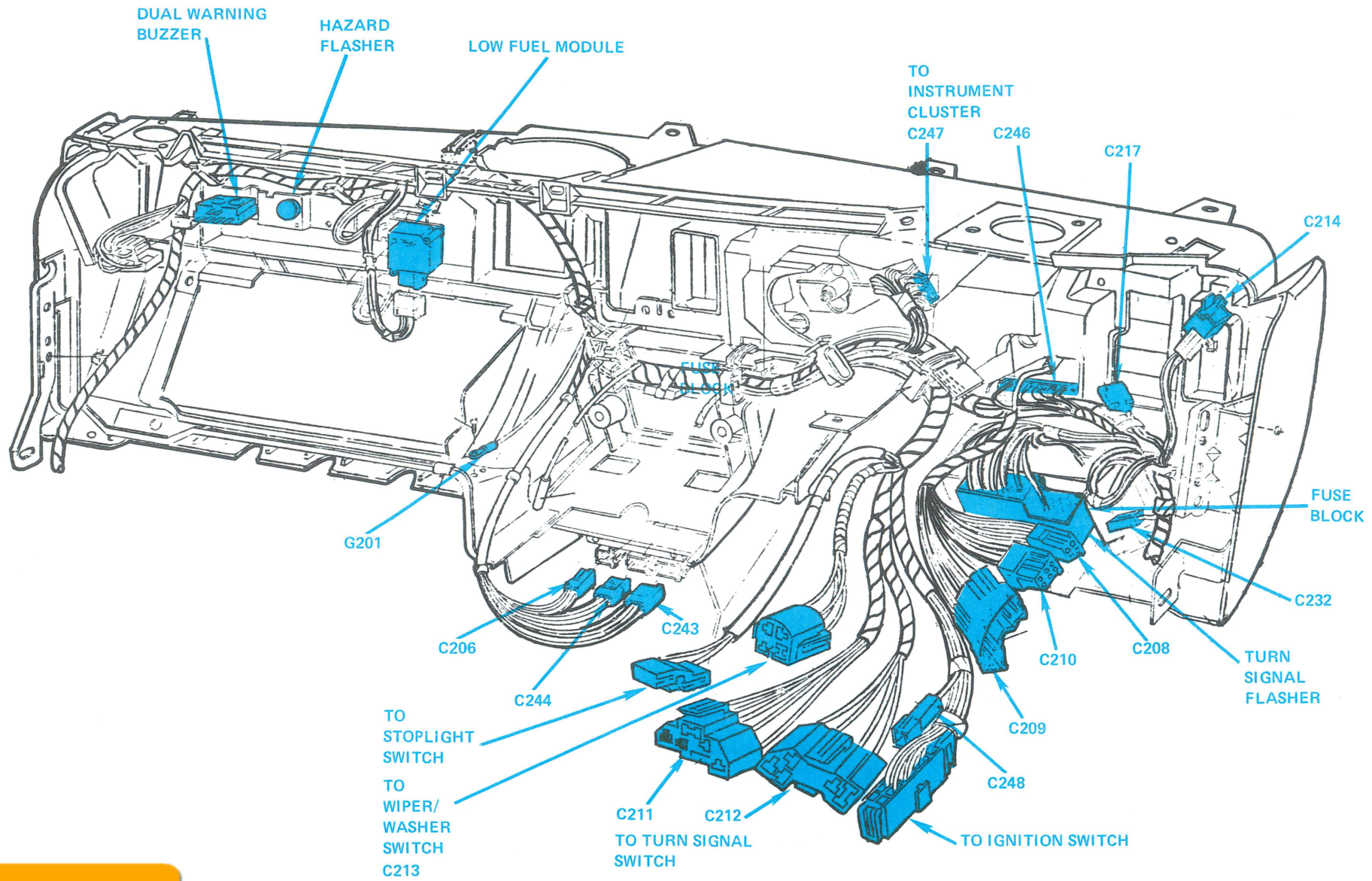

100% SATISFACTION GUARANTEED

BUY IT NOW!

[Click Here To Order](#)

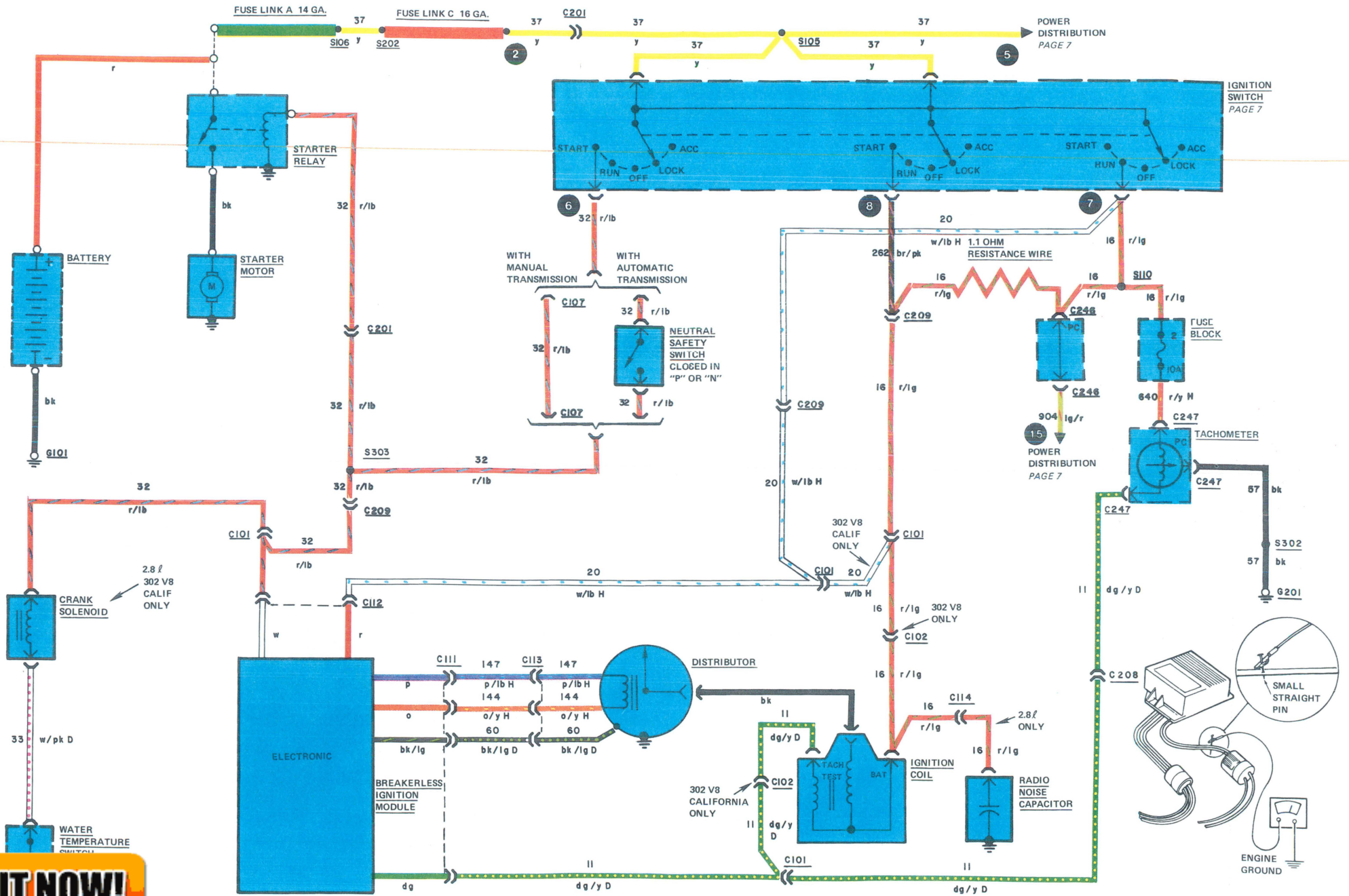

100% SATISFACTION GUARANTEED

BUY IT NOW!

Click Here To Order

START

HOW THE CIRCUIT WORKS

The Battery, Starter Motor, Starter Relay, and Ignition Switch make up the Starting System. In cars with automatic transmission, the Neutral Safety Switch must be closed (PARK or NEUTRAL).

Turning the Ignition Switch to START operates the Starter Relay. The Starter Relay sends power from the Battery to the Starter Motor to start the engine.

A Crank Solenoid is used on all California cars equipped with 302 CID V8 and 2.8 liter 6 cylinder engines. This solenoid supplies additional fuel during cold starts.

TROUBLESHOOTING HINTS

- Check condition of Battery. Replace or recharge if necessary. Check battery posts and terminals.
- Check cables for damage and proper connection.

ENGINE WILL NOT CRANK

- Listen for Relay click when Ignition Switch is turned to START position. If no click, check Ignition Switch, Neutral Safety Switch, and wiring to Relay for open connection.
- If Relay clicks, check voltage at terminal stud of Starter.
- Read "Routine 102 - Engine Will Not Crank" in Section 29-02 of Shop Manual.

100% SATISFACTION GUARANTEED BUY IT NOW! Click Here To Order [Logos: PayPal, American Express, Discover, MasterCard, VISA]

IGNITION

HOW THE CIRCUIT WORKS

The Ignition System generates high-voltage pulses to fire the spark plugs in proper sequence and timing.

The high-voltage pulses are generated in the Ignition Coil, a transformer with a low-voltage primary, and a high-voltage secondary.

Primary current is switched on and off by a solid state Ignition Module when signaled by the magnetic pickup in the Distributor. The magnetic pickup is installed close to a toothed rotor on the Distributor shaft. As each tooth passes by the magnetic pickup, a single pulse is generated, causing the Ignition Module to interrupt current to the primary of the Ignition Coil momentarily. Each interruption of current causes a sudden collapse of magnetic field in the Ignition Coil, producing a high voltage pulse of up to 40,000 volts in the coil secondary.

CAUTION In the Dura Spark II System, a high-voltage pulse is produced when the Ignition Switch is turned off.

The high-voltage pulses are transmitted to the Distributor, which sends them to the spark plugs.

Full Battery voltage is used for starting. When running, battery voltage is reduced by a 1.1 ohm resistor in series with the Ignition Coil. In California 302 V8 engines, this resistor is bypassed by the w/lb H jumper at C101. For this one engine, the coil is powered at full Battery voltage in RUN and START. A special Ignition Coil and Ignition Module (Duraspark I) are used for this engine.

TROUBLESHOOTING HINTS

CAUTION Catalytic converters are damaged by excessive unburned fuel. Disconnect air supply line between the bypass valve and the manifold before performing the following procedure. After testing, run the engine at least 3 minutes before reconnecting air supply line.

- Turn Ignition Switch OFF and remove air cleaner carefully. Inspect pressure and vacuum hoses for damage and proper connections.
- Check for loose or damaged spark plug or ignition coil wires. Clean and inspect wires one at a time. Repack each boot with silicone grease. When all wires are serviced, start car.
- If ignition system is still bad, turn Ignition Switch OFF. Remove ignition coil (center) wire from distributor and insert spark plug. Turn ignition on and ground side of spark plug against engine block. Tap base of distributor with screwdriver handle and watch for spark. If there is a good spark, skip down to "CRANKING TEST" on this page.
- If no spark, measure voltage of ignition module red wire without disconnecting 2-wire connector (see figure 10-1). If voltage is less than battery voltage, repair red wire circuit (w/lb H).
- If voltage equals battery voltage, turn Ignition Switch from RUN to OFF a few times. If a spark is seen when the switch is turned to OFF, replace the distributor.
- If no spark, turn Ignition Switch ON. Check voltage at BAT terminal of coil. If between 6 and 8 volts, replace Ignition

COMPONENT LOCATION

Table with columns: Component, Page-Figure, Shape, Color, Terminals. Lists components like Breakerless Ignition Module, Crank Solenoid, Starter Relay, and various connectors with their locations and terminal counts.

tion Module. If less than 6 volts, repair feed to BAT terminal. Tap distributor to check spark. If there is a good spark, system is ok. If there is no spark, replace the Ignition Coil.
- If BAT terminal voltage equals battery voltage, disconnect 4-wire connector at Ignition Module. Jumper the harness wires which mate to the module dg and bk/lg wires. Again check voltage at BAT terminal. If voltage is 6 to 8 volts, replace the Ignition Module.
- If BAT terminal voltage still equals battery voltage, ground TACH TEST terminal. Check voltage at BAT terminal. If voltage is equal to battery voltage replace the ignition coil. If voltage is 6 to 8 volts, repair ground circuit (mates to ignition module bk/lg wire). If voltage is less than 6 volts, repair power circuit (mates to ignition module dg wire). Remove jumper and reconnect module. Tap distributor to

check spark. If there is a good spark, system is ok.
CRANKING TEST
- Hold connected spark plug against engine block. Turn Ignition Switch to START and crank engine. If there is a good spark, the ignition system is ok.
- If no spark, measure voltage of ignition module white wire without disconnecting 2-wire connector (see figure 10-1). Turn Ignition Switch to START and crank engine. If voltage is less than battery voltage, repair white wire circuit (r/lb).
- If voltage equals battery voltage, measure voltage at BAT terminal of coil while cranking. If voltage equals battery voltage, replace Ignition Module. If BAT terminal voltage is less than battery voltage, repair 262 br/pk or 16 r/lg circuit.
- For more details, see "Engine Diagnosis and Service," Section 29-02 of Shop Manual.

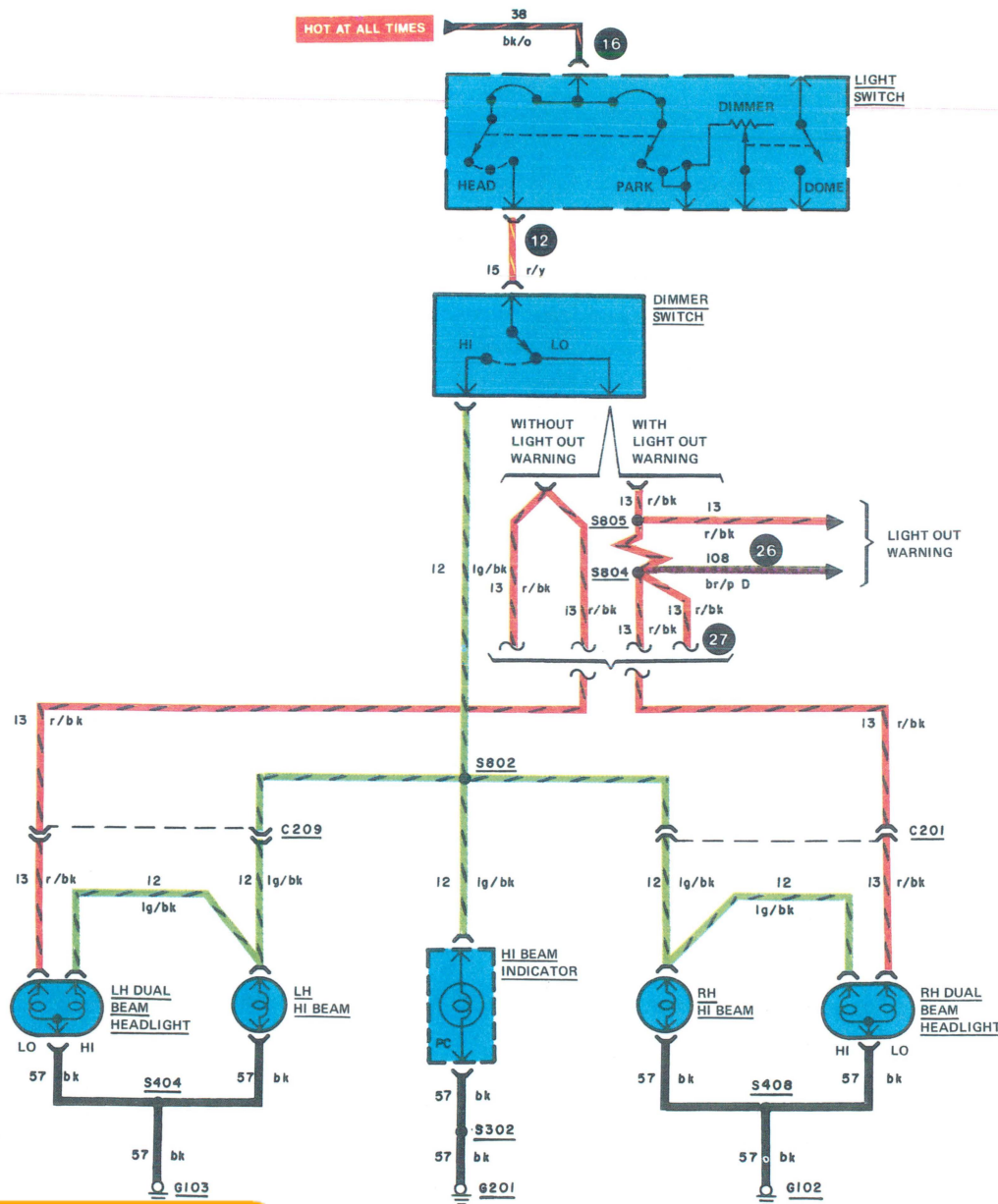

COMPONENT LOCATION HEADLIGHTS

		Page-Figure	Shape	Color	Terminals
Connector C201	LH cowl in "A" pillar	8-1		gr	8
Connector C209	Behind instrument panel	9-1		gy	11
Ground G102	RH front fender	5-2			
Ground G103	LH front fender				
Ground G201	Behind center of instrument panel	9-1			

EXTERIOR LIGHTS

Connector C106	RH and LH side marker lights			br	2
Connector C201	RH and LH cowl side	8-1		gr	8
Connector C216	LH cowl side, in "A" pillar	8-1		gy	8
Connector C233	Near brake warning indicator switch			gy	1
Connector C302	LH side of rear window	31-1		gy	3
Connector C303	LH rear fender apron			-	1
Ground G102	RH front fender	5-2			
Ground G103	LH front fender				
Ground G203					
Ground G301	On deck lid striker	17-1			
Ground G302	On deck lid striker				
Ground G303	Near license lights				
Ground G304	LH fender apron				

TROUBLESHOOTING HINTS

HEADLIGHTS

NO EXTERIOR LIGHTS

- Look for frayed or damaged wires or loose connections.
- Make sure connector is securely mated to Light Switch.
- Check for power at bk/o wire of Light Switch. If bad, check harness back to Battery.
- Check continuity of switch. Replace if bad.

NO HEADLIGHTS; PARK LIGHTS OK

- Check for power at r/y wire of Dimmer Switch. If bad, check continuity of wire and Light Switch.

- Check continuity of Dimmer Switch. Replace if bad.

NO HI AND LO BEAM ON ONE SIDE

- Make sure ground connection on that side is clean and tight.

EXTERIOR LIGHTS

NO EXTERIOR LIGHTS OPERATION

- If Instrument (dimmer) Lights work, check continuity of br wire in harness.
- If no Instrument Lights work, replace Light Switch.

ONE LIGHT DOES NOT OPERATE

- Check bulb.
- Check for frayed or damaged wires or loose connections.

100% SATISFACTION GUARANTEED

BUY IT NOW!

Click Here To Order

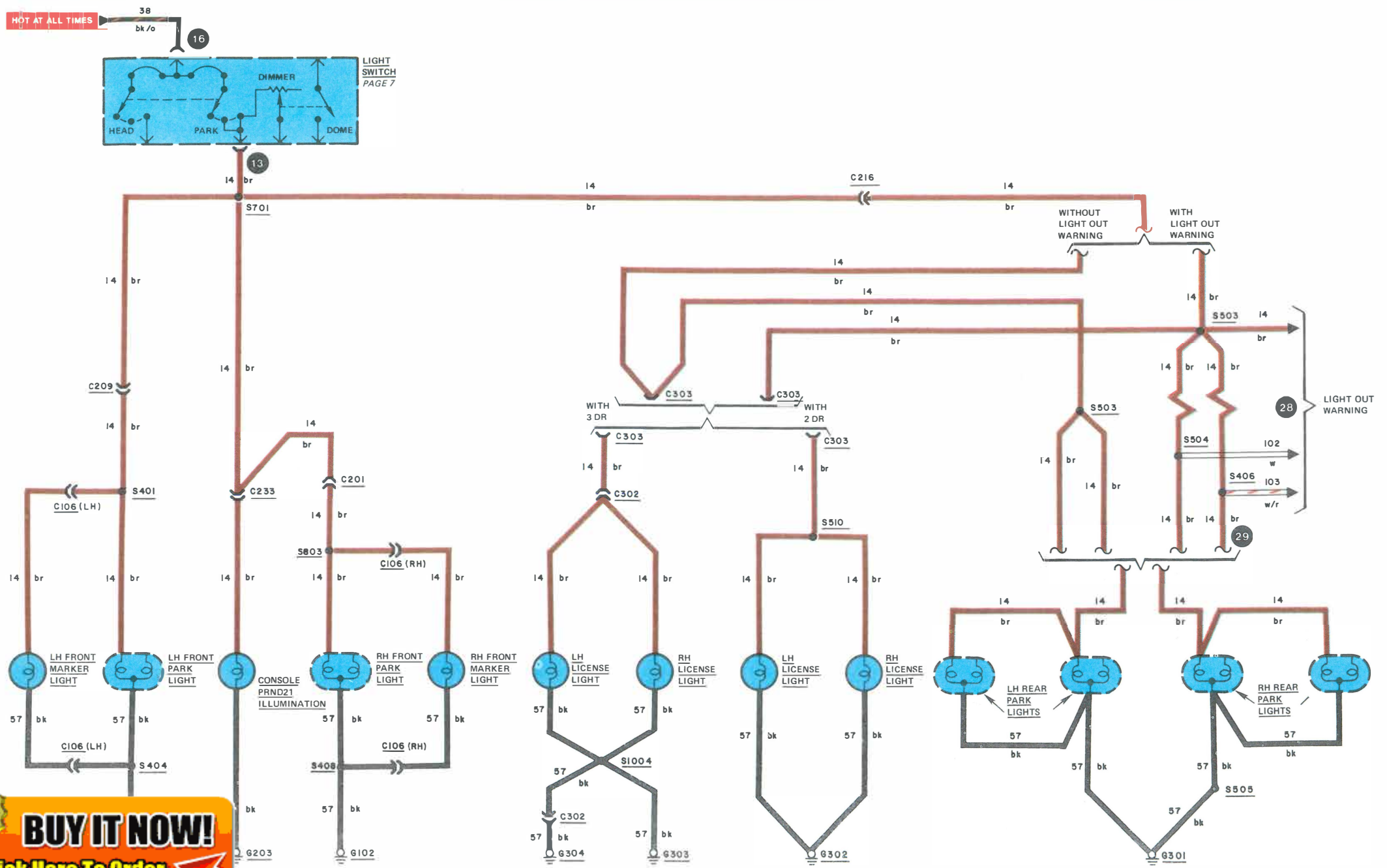

100% SATISFACTION GUARANTEED

BUY IT NOW!

Click Here To Order

PayPal
American Express
Discover
MasterCard
VISA

BUY IT NOW!
Click Here To Order

100% SATISFACTION GUARANTEED



**WE SUPPORT VOLUNTARY
MECHANIC CERTIFICATION**



Ford Parts and Service Division
Training and Publications Department