

1978 Truck Wiring Diagrams



Covers Models

Bronco
Econoline
F100-350 Series

*Complete Set of Original OEM
Ford Motor Company Wiring Diagrams*



Ford Parts and Service Division
Training and Publications Department



Official
Licensed
Product

License #2013225

Copyright © 2015, Forel Publishing Company, LLC, Woodbridge, Virginia

All Rights Reserved. No part of this book may be used or reproduced in any manner whatsoever without written permission of Forel Publishing Company, LLC. For information write to Forel Publishing Company, LLC, 3999 Peregrine Ridge Ct., Woodbridge, VA 22192

1978 Ford Truck Wiring Diagrams (Bronco, Econoline, F100-350 Series)

EAN: 978-1-60371-206-4

ISBN: 1-60371-206-2

Forel Publishing Company, LLC

3999 Peregrine Ridge Ct.

Woodbridge, VA 22192

Email address: sales@ForelPublishing.com

Website: <http://www.ForelPublishing.com>



License #2013225

This publication contains material that is reproduced and distributed under a license from Ford Motor Company. No further reproduction or distribution of the Ford Motor Company material is allowed without the express written permission of Ford Motor Company.

Note from the Publisher

This product was created from the original Ford Motor Company's publication. Every effort has been made to use the original scanned images, however, due to the condition of the material; some pages have been modified to remove imperfections.

Disclaimer

Although every effort was made to ensure the accuracy of this book, no representations or warranties of any kind are made concerning the accuracy, completeness or suitability of the information, either expressed or implied. As a result, the information contained within this book should be used as general information only. The author and Forel Publishing Company, LLC shall have neither liability nor responsibility to any person or entity with respect to any loss or damage caused, or alleged to be caused, directly or indirectly by the information contained in this book. Further, the publisher and author are not engaged in rendering legal or other

advice, mechanical, electrical, or other expert assistance is required, the professional should be sought.



How to Print Wiring Diagram Pages

Many of the original Ford wiring manuals were created in a very large format (11x17, 17x24, and 17x36) making it difficult to print on a standard home printer. Some printers will print only a portion of the entire page, while others will shrink the page into an unreadable format. However, Adobe Reader has the ability to print sections (known as Tiles) of the page onto standard 8.5x11 paper. Please use the steps below to print these wiring diagrams.



You can print a large format document, such as these wiring diagrams, by splitting the page across multiple sheets of paper (called "tiling"). The tiling option calculates how many sheets of paper are needed. You can adjust the size of the original to best fit the paper and specify how much each "tile" overlaps. You can then piece together the tiles.

1. Choose File > Print.
2. From the Page Scaling pop-up menu, select one of the following options:
Tile Large Pages Tile only the pages that are larger than the paper.
Tile All Pages Tile all the pages in the PDF file.

Note: If the tile options are not in the menu, make sure that the following options are not selected in the Advanced Print dialog box: Print As Image or, for Acrobat only, Separations or In-RIP Separations. Also check your version of Reader. Reader 9 does not support tiling.

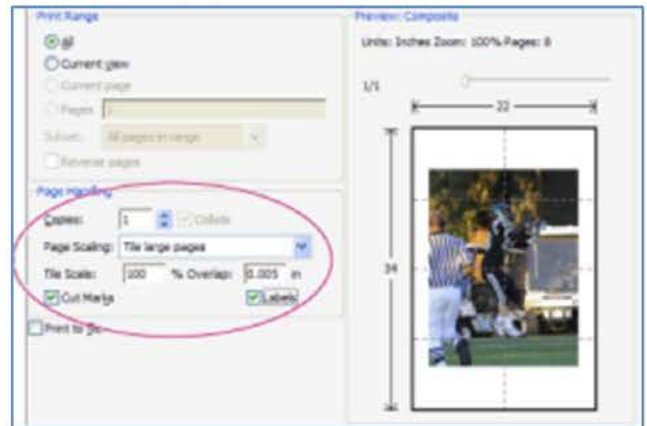

3. Set the following options as needed:
Tile Scale Scales the pages by the amount you specify.
Overlap Determines the amount each tile overlaps adjacent tiles.
Cut Marks Adds guide marks to each page to help you trim the overlap.
Labels Adds the filename and page number on each "tile".

4. Click OK or Print.

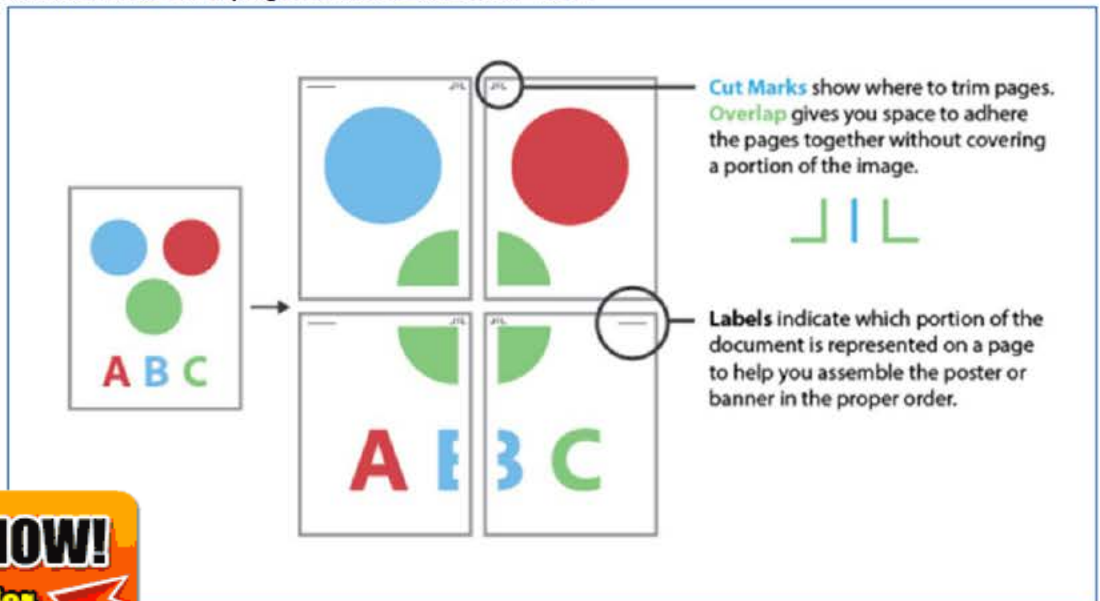

BUY IT NOW!

Click Here To Order



How to Print a Portion of a Wiring Diagram



You can print a portion of a page in a PDF. The Snapshot Tool lets you select just the area you want to print. The area can be text, graphics, or both. You can print the selected area full size or resize it to fit the paper.

1. Open the PDF in Adobe Reader or Adobe Acrobat.

2. (Acrobat X/Reader X) Choose Edit > Take A Snapshot.
(Acrobat 9/Reader 9) Choose Tools > Select & Zoom > Snapshot Tool.

3. Drag a rectangle around the area you want to print.

4. Choose File > Print.

5. Make sure that the **Selected Graphic** option is selected in the Print Range area of the Print dialog box.

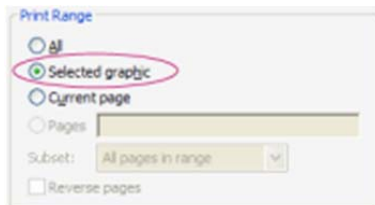

6. (Optional) To enlarge the selected text or graphic to fit the sheet of paper, choose Fit To Printable Area from the Page Scaling pop-up menu.

Note: Enlarging the area reduces the printed resolution.

7. Click OK or Print.



How to Print a Portion of a Wiring Diagram

Print Current View

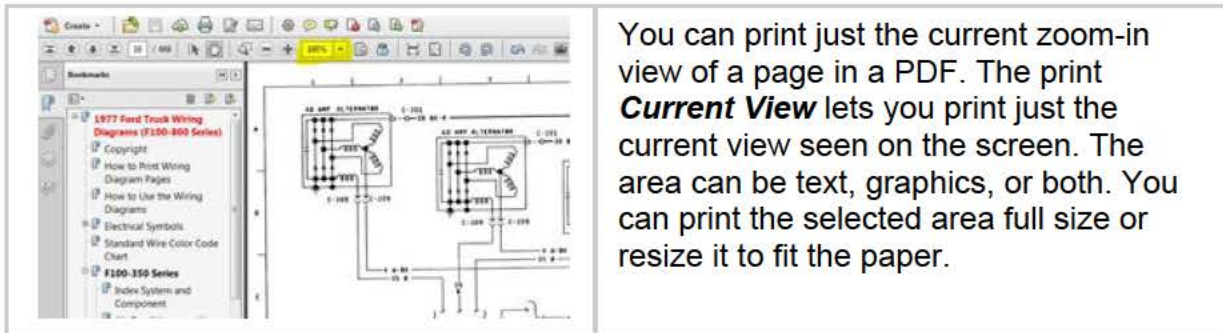

1. Open the PDF in Adobe Reader or Adobe Acrobat.
2. Zoom into the portion of the diagram you want to print.
3. Choose File > Print.

4. Make sure the **Current View** option is selected in the Pages to Print area of the Print dialog box.

Note – To select Current view, you may need to click the “More Options” dropdown.

5. (Optional) To enlarge the selected text or graphic to fit the sheet of paper, choose Fit To Printable Area from the Page Scaling pop-up menu.

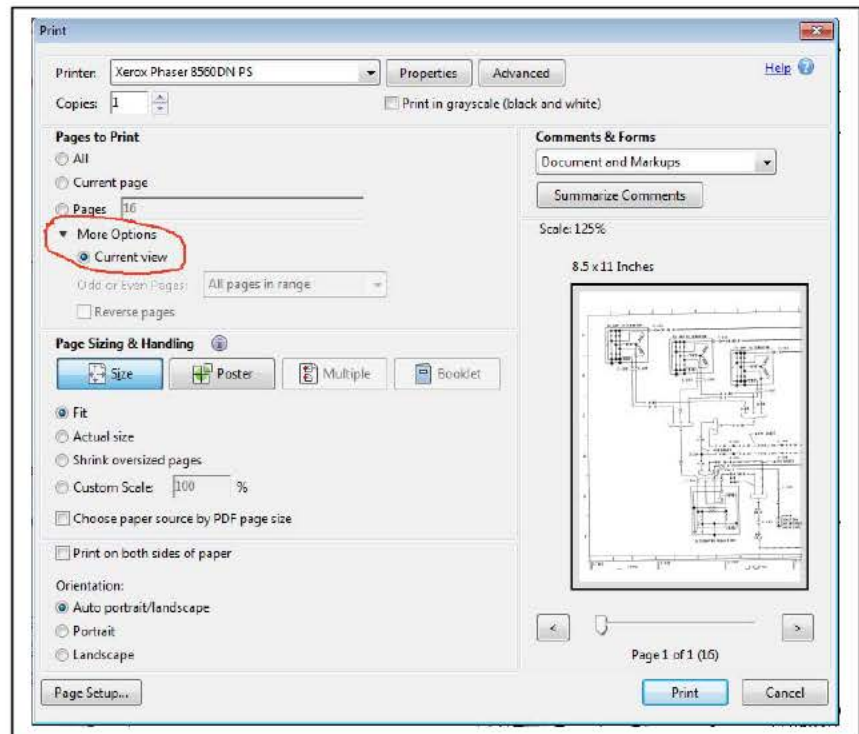

Note: Enlarging the area reduces the printed resolution.

6. Click OK or Print.

100% SATISFACTION GUARANTEED

BUY IT NOW!

Click Here To Order

PayPal | American Express | Discover | MasterCard | VISA

1978 TRUCK WIRING DIAGRAMS

- Bronco
- Econoline
- Parcel Delivery
- F-100-350 Series
- F-600-800 Series (Cab)
- B-F-600-800 Series (Cowl)
- C-Series
- L-Series (Line Haul)
- L-Series (City Delivery)
- CL-Series

 Ford Parts and Service Division
Training and Publications Department

The illustrations contained in this book were in effect at the time the book was approved for printing. Ford Motor Companies, whose policy is one of continuous improvement, reserves the right to discontinue models at any time, or to change specifications or design, without notice and without incurring obligations.

HOW TO USE THE WIRING DIAGRAMS

INDEX

An INDEX is provided behind the divider for each truck series. The index page contains an alphabetically arranged list of systems and components and a bulb usage list. The index lists the location of the components on the drawing. Examples of the two types of index references are shown:

- To locate an electrical part at D-49, find the location number 49 at the top of the illustration. Then, find the letter D on the side of the illustration. Follow the number and the letter until the lines intersect. The part will be within an inch or two of the intersection.
- To locate an electrical part at PG3-D10, turn to page 3 as indicated in the lower right corner of the sheet. Then, find the number 10 at the top of the illustration and the letter D on the side of the illustration. Follow the number and the letter until the lines intersect. The part will be within an inch or two of the intersecting lines.

BASIC INFORMATION

Generally, the power supply for all components on this drawing comes from the top of the page and over to the battery at the left.

The ground for each component is always toward the bottom of the drawing that are explained as follows:

- Ground symbols are shown in Figure 1. A ground wire connected away from the component is identified by a code G1 or G2, etc. Location of the remote ground is listed in the diagram.

- Wire color code is shown in Figure 2. Wire color codes (by color) are listed on page 5.

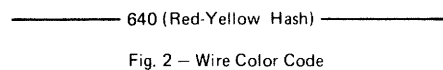

If a vehicle specific wire color in a connector does not match the diagram shown, it can usually be identified by comparing the other colors shown at the wire connectors. Specific wire color deviations in the manufacturing of a wire harness are usually for a short duration.

- Harness number is shown in Figure 3. The 5 or 6 digit number near the wire indicates the wire harness basic part number.

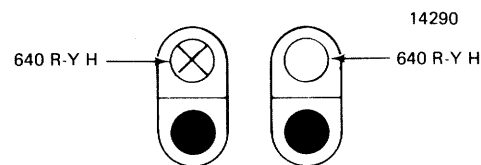
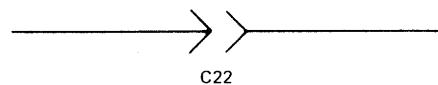

Fig. 3 - Harness Number

- Wire connector identification code is shown in Figure 4. The key for the connector codes is located at the bottom of the wiring diagram.



- Male connector symbol is illustrated in Figure 5. The symbol used for the diagram and chart is shown.

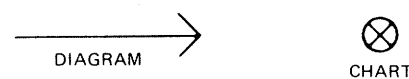
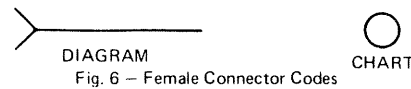
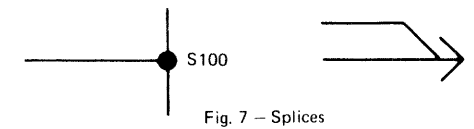

Fig. 5 - Male Connector Codes

- Female connector symbol is shown in Figure 6.



- Splice is shown in Figure 7. A splice is a common point where two wires are joined together. Location of splice is at bottom of schematic page.



- Heavy lines for the wires indicate a direct to battery feed.
- Heavy dashed lines indicate an ignition switch accessory feed.

Electrical symbols used in the schematics are illustrated and described below and on the next page.

ELECTRICAL SYMBOLS

BASIC SYMBOLS

- ↗ = A TERMINAL CONNECTION
- ↘ = A FEMALE TERMINAL
- ↖ = A MALE TERMINAL
- = A GRAPHIC FEMALE ROUND TERMINAL. AND/OR A SWITCH CONTACT. AND/OR A STUD ON A COMPONENT.
- ⊗ = A GRAPHICS MALE TERMINAL (STD.)
- = A SPLICE. AND/OR A CHASSIS CONNECTION. AND/OR A GRAPHICS EMPTY CONNECTOR CAVITY FOR A STANDARD ROUND PIN TERMINAL.
- (large) = A GRAPHICS BIG FEMALE TERMINAL
- ⊗ (large) = A GRAPHICS BIG MALE TERMINAL
- (large) = A GRAPHICS EMPTY CONNECTOR CAVITY FOR A BIG ROUND TERMINAL.
- (empty) = A GRAPHICS ARCLESS FEMALE TERMINAL
- (with cross) = A GRAPHICS ARCLESS MALE TERMINAL
- (empty) = A GRAPHICS EMPTY CONNECTOR CAVITY FOR ARCLESS TERMINALS.
- ⌋ = A WIRE TERMINATION
- ⊥ = AN EYELET TERMINAL GROUND
- ⊥ (with dot) = A CHASSIS GROUND
- ⊥ (with dash) = A SINGLE EYELET CONNECTION
- ⊥ (with circle) = AN EYELET CONNECTION TO A STUD. OR A SERIES OF EYELET CONNECTIONS.
- (with dot) = WIRE SHIELD
- ⊥ (with square) = JUNCTION BLOCKS
 - 1 = SINGLE TERMINAL
 - 2 = DOUBLE TERMINAL
 - 3 = DOUBLE TERMINAL WITH BUSS BAR
- ▲ = MOMENTARY SWITCH CONTACT
- △ = DISTRIBUTOR SWITCH CONTACT
- ⊥ (with circle) = BREAK BEFORE MAKE SWITCH WIPER (THREE OR MORE POSITIONS)
- ⊥ (with square) = MAKE BEFORE BREAK SWITCH WIPER (THREE OR LESS POSITIONS)
- ⊥ (with circle) = HINGED PALL SWITCH WIPER (THREE OR LESS POSITIONS)
- ⊥ (with T) = A PUSH OR PULL SWITCH WIPER
- ⌋ (zigzag) = A FIXED RESISTANCE
- ⌋ (wavy) = A VARIABLE RESISTANCE
- ⌋ (with cross) = A THERMISTOR
- ⌋ (with T) = A POTENTIOMETER OR A RHEOSTAT. DEPENDING ON EXTERNAL CIRCUITY.
- ⌋ (with T) = A FIXED CAPACITOR
- ⌋ (with T) = A VARIABLE CAPACITOR
- ⌋ (with zigzag) = A HEATER AND/OR TEMPERATURE SENSITIVE ELEMENT
- ⌋ (with circles) = VARIOUS SIZE FUSES (USED WITH FUSE PANELS)
- ⌋ (with square) = AN INLINE FUSE & HOLDER
- ⌋ (with circle) = A CIRCUIT BREAKER (FUSE PANEL MOUNTED) (SELF RE-SETTABLE)
- ⌋ (with circle) = A CIRCUIT BREAKER (FUSE PANEL MOUNTED) (MANUALLY RE-SETTABLE)
- ⌋ (with square) = AN INLINE CIRCUIT BREAKER (SELF RE-SETTABLE)
- ⌋ (with zigzag) = A COIL AND/OR INDUCTOR (W/O IRON CORE)
- ⌋ (with zigzag) = A COIL AND/OR INDUCTOR (WITH IRON CORE)
- ⌋ (with cross) = A DIODE
- ⌋ (with cross) = A SILICON CONTROL RECTIFIER
- ⌋ (with cross) = A ZENER DIODE
- ⌋ (with square) = AN INLINE DIODE
- ⊗ (circle) = A TRANSISTOR (PNP)
- ⊗ (circle) = A TRANSISTOR (NPN)

100% SATISFACTION GUARANTEED

BUY IT NOW!

Click Here To Order

PayPal, American Express, Discover, MasterCard, VISA

ELECTRICAL SYMBOLS

COMPONENT SYMBOLS

MISCELLANEOUS COMPONENTS

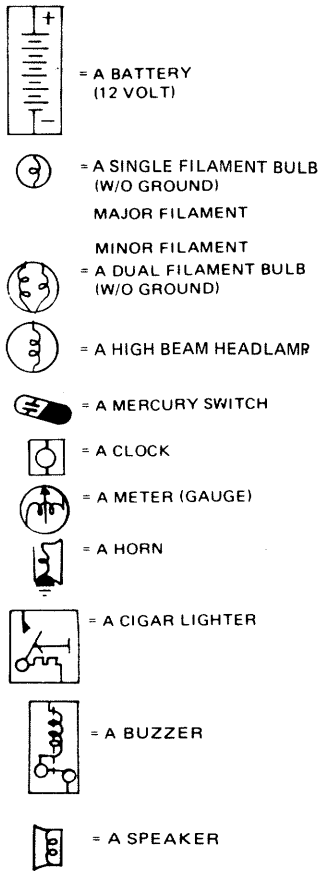

RELAYS

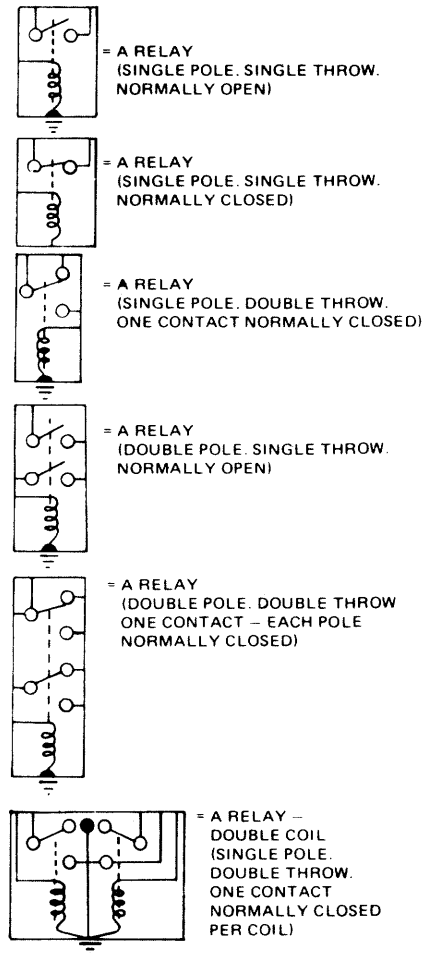

HINGED PALL SWITCHES

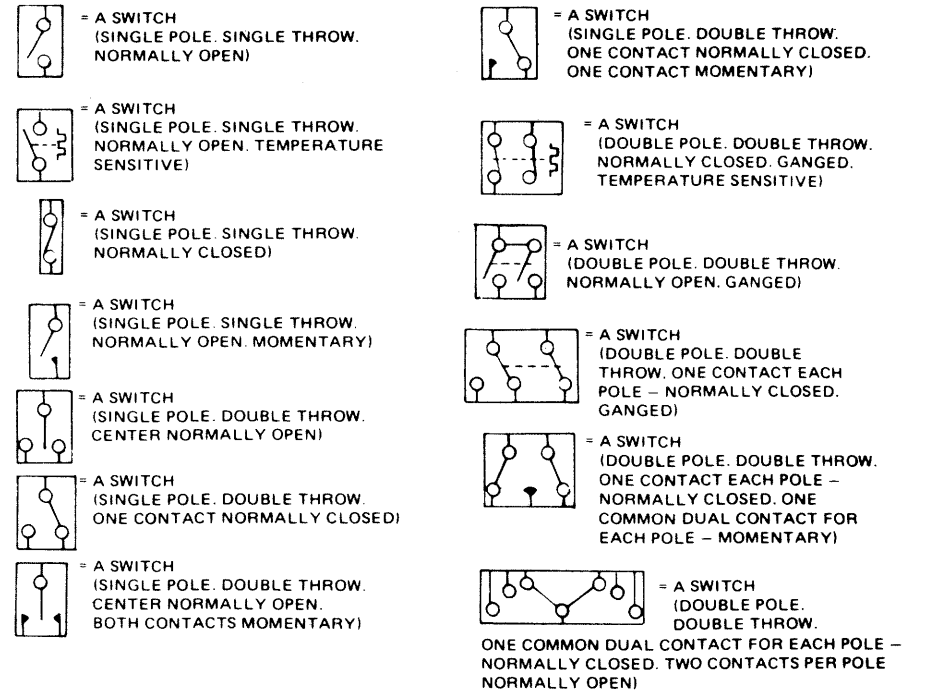

SOLENOIDS

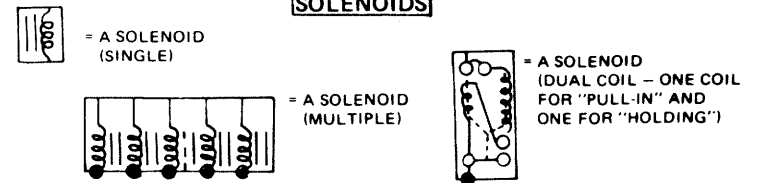

SPLICES

SPLICED WIRES SHALL BE REPRESENTED BY:

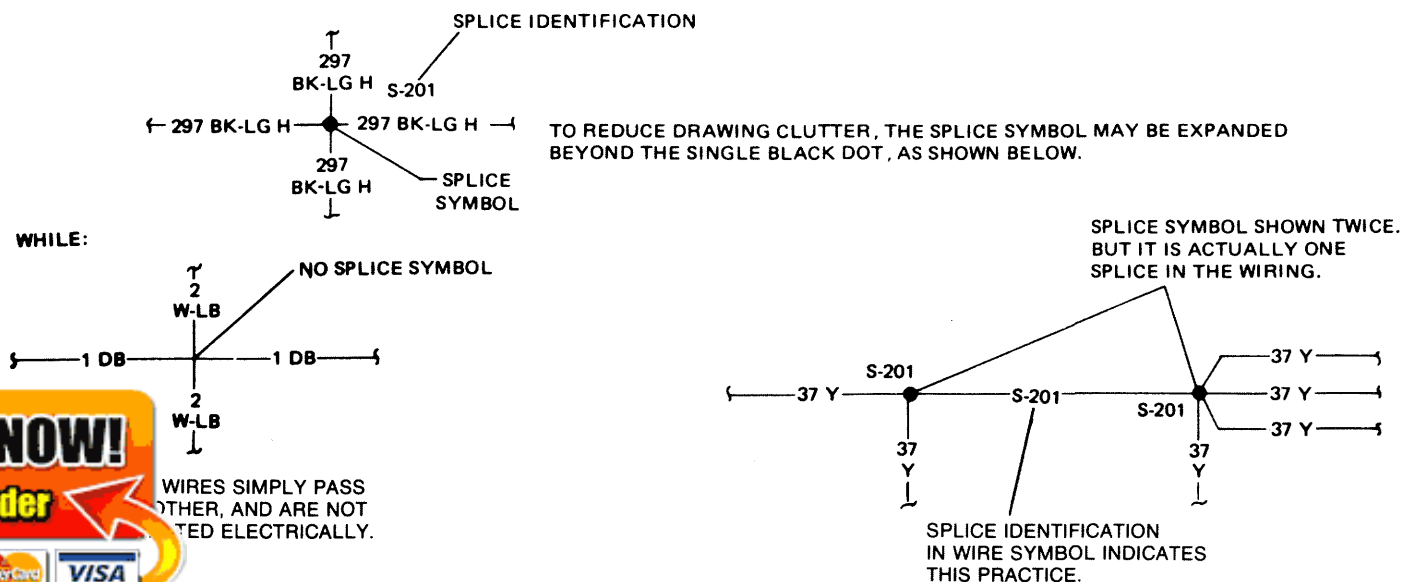

100% SATISFACTION GUARANTEED

BUY IT NOW!

Click Here To Order

Wires simply pass through each other, and are not connected electrically.

PayPal American Express Discover Novus MasterCard VISA

PUSH-PULL SWITCHES

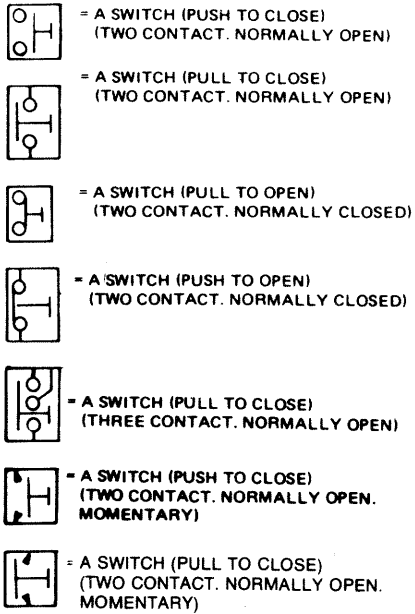

MULTIPLE POSITION SWITCHES

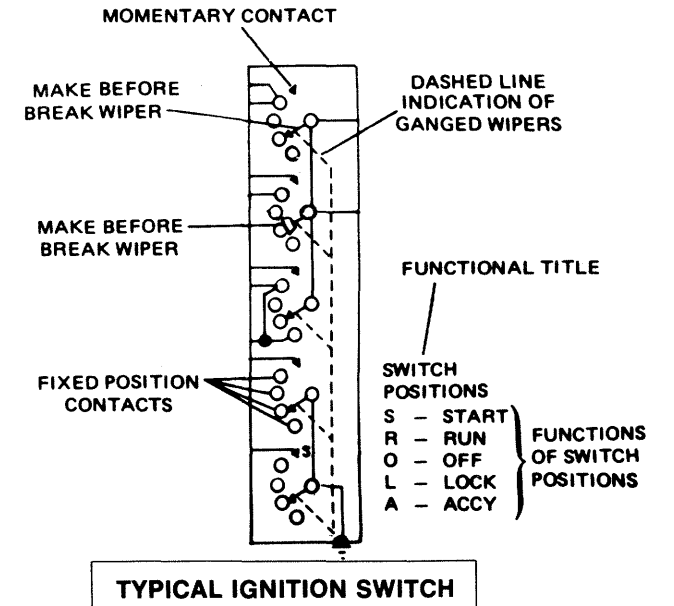
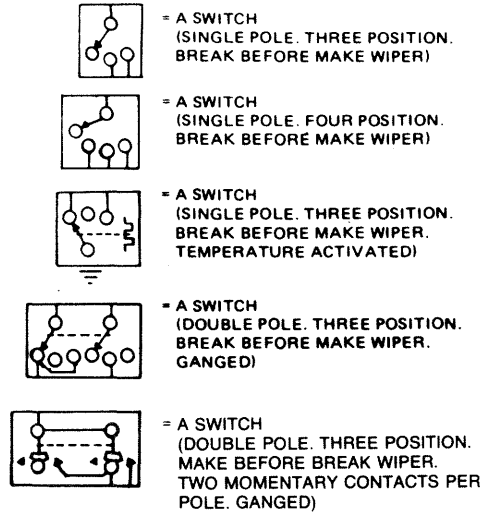

SOCKETS

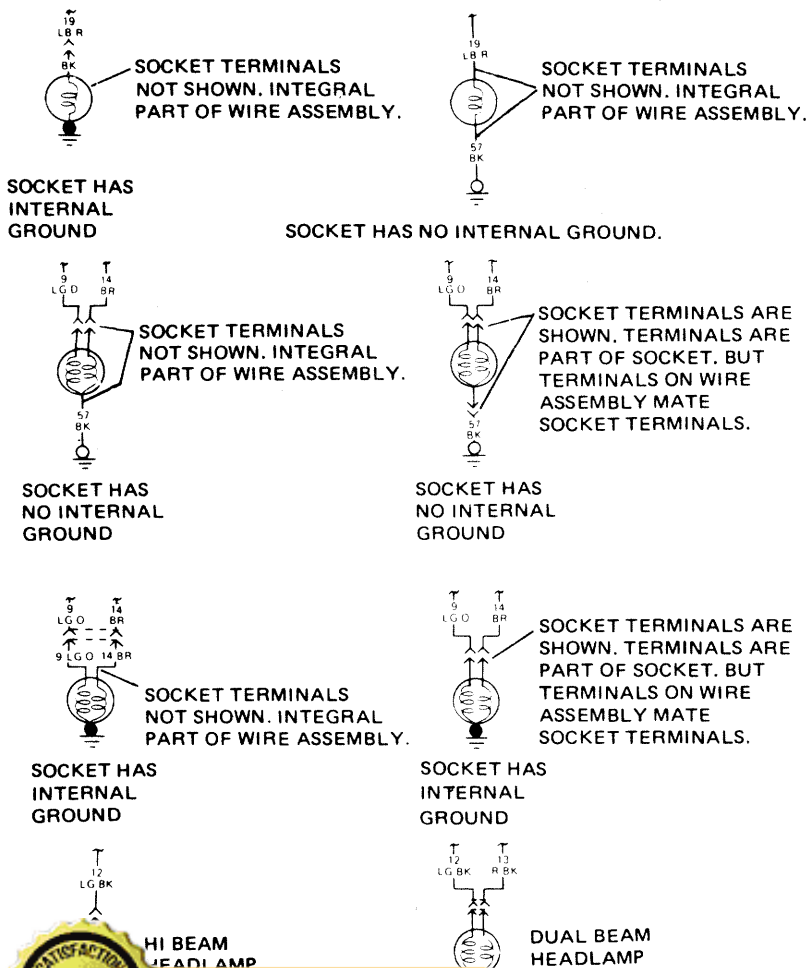

VARIOUS MOTOR TYPES

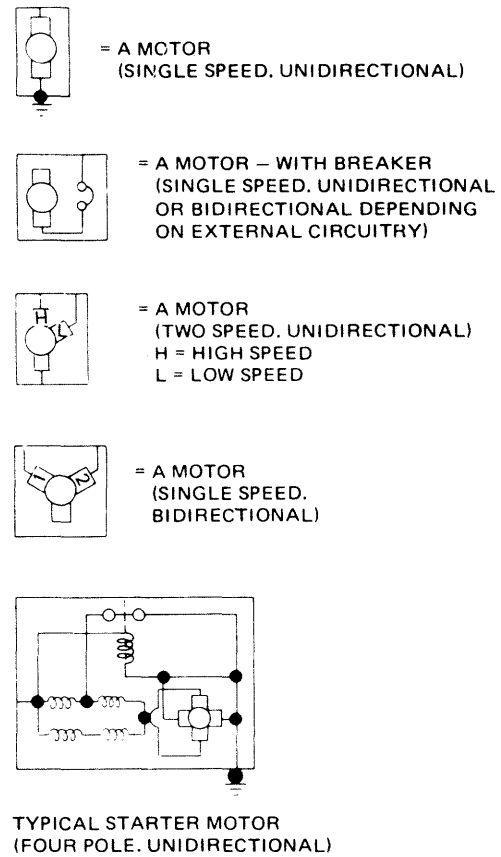

TYPICAL DISTRIBUTORS

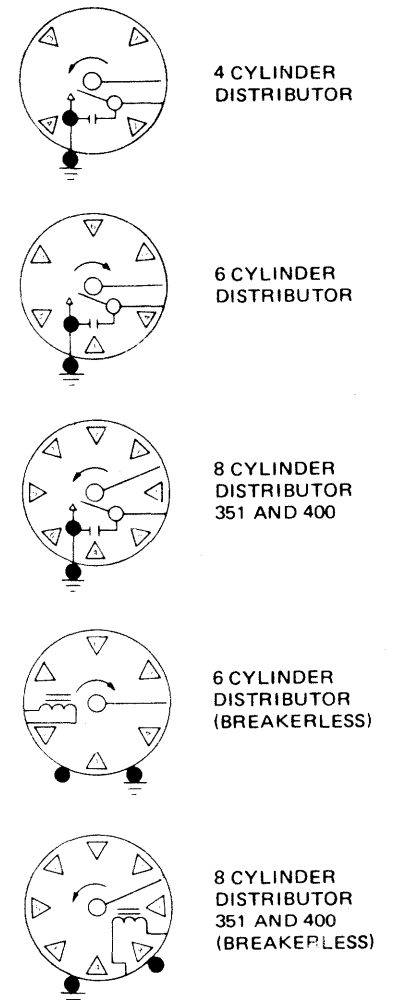

C-201

100% SATISFACTION GUARANTEED

BUY IT NOW!

Click Here To Order

PayPal, American Express, Discover, MasterCard, VISA

ELECTRICAL SYMBOLS

COMPONENT TERMINATIONS

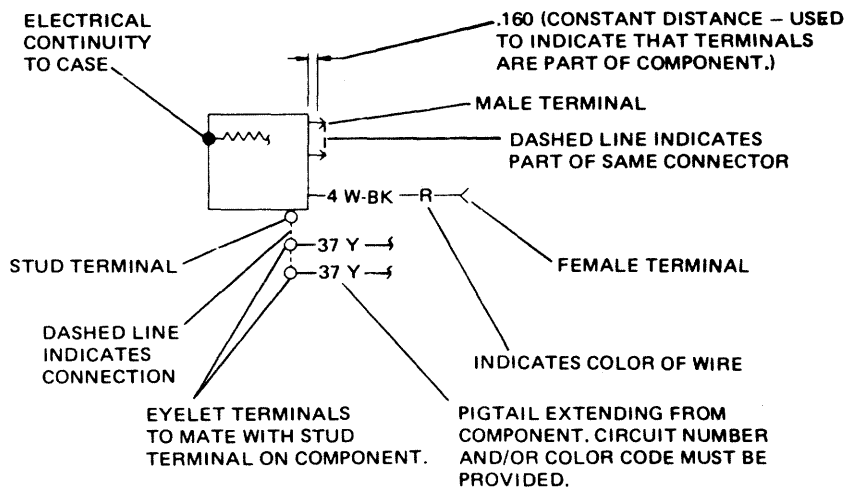

GROUND INDICATIONS

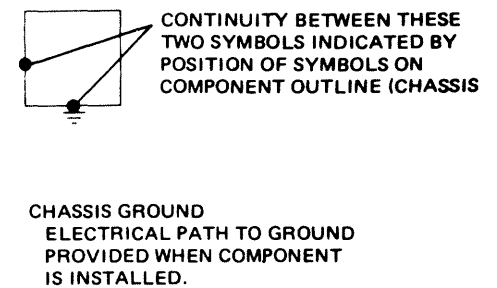
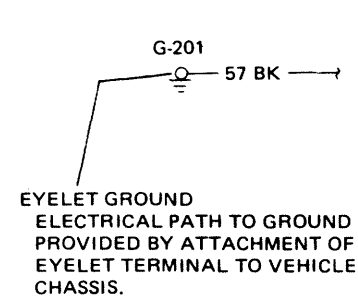

TERMINALS AND CONNECTORS

AS USED ON THE DIAGRAMS, INDIVIDUAL TERMINALS SHALL BE REPRESENTED BY:

- A. → MALE
- B. ← FEMALE
- C. ○ EYELET

TERMINALS PHYSICALLY LOCATED IN THE SAME CONNECTOR SHELL MAY BE REPRESENTED SEPARATELY ON THE DIAGRAM. I.E.

→ C-201

OR DESIGNATED AS BEING IN THE SAME CONNECTOR SHELL. I.E.

→ C-201 ← DASHED LINE INDICATES TERMINALS ARE IN SAME CONNECTOR SHELL.

MATING TERMINALS ARE, THEREFORE, REPRESENTED AS:

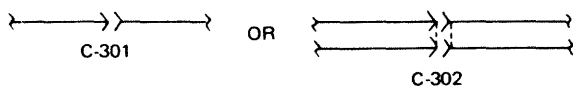

TWO WIRES PHYSICALLY ATTACHED TO A SINGLE TERMINAL ARE REPRESENTED BY:

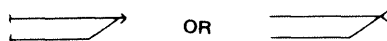

WIRE TYPES

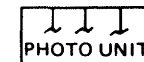
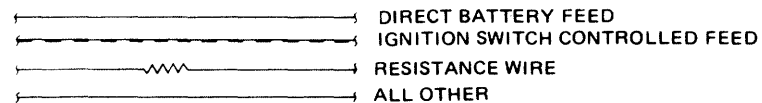

TYPICAL EXAMPLES OF COMPONENTS WITH UNDEFINED INTERNALS.

USED IN CASES WHERE COMPONENTS ARE NOT SERVICEABLE AND ARE CONSIDERED REPLACEABLE ONLY. AND INTERNAL CIRCUITRY IS NOT CONSIDERED NECESSARY FOR CLEAR UNDERSTANDING OF ASSOCIATED WIRING AND COMPONENTS.

100% SATISFACTION GUARANTEED

BUY IT NOW!

Click Here To Order

PayPal | American Express | Discover | MasterCard | VISA

STANDARD WIRE COLOR CODE CHART

CIRCUIT	DESCRIPTION	COLOR	CIRCUIT	DESCRIPTION	COLOR
1	HORN SWITCH TO HORN RELAY	BLUE-YELLOW STRIPE	96	WINDSHIELD WIPER CONTROL SW. TO W/S WIPER MOTOR GRND.	ORANGE-BLACK STRIPE
2	TURN SIGNAL SW. TO RH FRONT TURN SIGNAL LAMP	WHITE-BLUE STRIPE	98	"A" TERM. IGN. SW. TO ALT. REG. "IGN." TERM	BLACK
3	TURN SIGNAL SWITCH TO LH FRONT TURN SIGNAL LAMP	GREEN-WHITE STRIPE	99	CONTROL SWITCH TO IGNITION SWITCH	BLACK
4	ALTERNATOR REG. "S" TERM. TO ALTERNATOR "S" TERM.	WHITE-BLACK STRIPE	100	CONTROL SWITCH TO VOLTAGE REGULATOR	BLACK-RED STRIPE
5	ENGINE BRAKE SWITCH "ON" TO FUSE PANEL	RED-BLACK STRIPE	101	REMOTE CONTROL MIRROR SWITCH FEED	GRAY
6	HORN RELAY TO HORN	YELLOW-GREEN STRIPE	102	REMOTE CONTROL MIRROR SWITCH TO CONTROL UNIT	PURPLE
7	ENGINE BRAKE SWITCH "OFF" TO CLUTCH SWITCH	GREEN	103	REMOTE CONTROL MIRROR SWITCH TO CONTROL UNIT	BLACK
8	IGNITION SWITCH TO TURN SIGNAL FLASHER	ORANGE-YELLOW STRIPE	104	REMOTE CONTROL MIRROR SWITCH TO CONTROL UNIT	GREEN
9	CLUTCH SWITCH TO JUNCTION BLOCK	GREEN	109	BATTERY TO STARTER MOTOR RELAY FEED	YELLOW
10	FUSE PANEL TO STOPLAMP SWITCH	GREEN-RED STRIPE	110	FUEL TANK SOLENOID VALVE TO AUX. CIRC. BREAKER	BLACK-GREEN STRIPE
11	HEADLAMP SWITCH TO PARKING LAMPS	BLACK-YELLOW STRIPE	112	WARNING LAMP RELAY FEED	RED
12	HEADLAMP DIMMER SWITCH TO HIGH BEAMS	GREEN-BLACK STRIPE	113	STARTER MOTOR TO STARTER MOTOR RELAY	YELLOW-BLACK STRIPE
13	HEADLAMP DIMMER SWITCH TO LOW BEAMS	RED-BLACK STRIPE	117	DOOR LOCK MOTOR (LOCK)	PINK-BLACK STRIPE
15	HEADLAMP SWITCH TO HEADLAMP DIMMER SWITCH	RED-YELLOW STRIPE	118	HEATER RELAY TO HEATER CIRC. BREAKER	RED
16	IGNITION SWITCH TO IGNITION COIL "BATT." TERMINAL	RED-GREEN STRIPE	119	DOOR LOCK SWITCH (LOCK)	PINK-YELLOW STRIPE
17	LOW OIL PRESSURE WARNING LAMP TO LOW OIL PRESS. SNDG. UNIT	WHITE	120	CIRCUIT BREAKER (POWER & CHARGING) TO FUSE PANEL	BLACK
18	AUX. CIRC. BREAKER TO GLOVE BOX LAMP	BLACK-BLUE STRIPE	121	DOOR LOCK SWITCH (UNLOCK)	PINK-GREEN STRIPE
19	HEADLAMP SWITCH TO INSTRUMENT PANEL LAMPS	BLUE-RED STRIPE	122	DOOR LOCK MOTOR (UNLOCK)	PINK-ORANGE STRIPE
21	BATTERY TO IGNITION SWITCH FEED	YELLOW	128	STARTER MOTOR RELAY TO STARTER MOTOR	BLACK
22	BRAKE FEED	BLUE-BLACK STRIPE	129	GLOW PLUG C.B. TO GLOW PLUG SW.	GREEN
23	CIRCUIT BREAKER TO VOLTAGE DIVIDER	ORANGE	130	ACCESSORY RELAY "ARM./TERM." TO ACCY. TERM. OF FUSE PANEL	YELLOW
24	ALTERNATOR OUTPUT (24 VOLTS) TO STARTER MOTOR	BLUE-YELLOW STRIPE	132	MOTOR TO GROUND (2 SPEED AXLE)	GREEN
25	JUNCTION BLOCK TO HEADLAMP SWITCH	BLACK-ORANGE STRIPE	136	TWO SPEED AXLE SWITCH TO TWO SPEED ADAPTER	BLACK
26	ALTERNATOR GROUND (NEG. TERM.)	BLACK-RED STRIPE	137	FUSE PANEL TO RADIO	YELLOW-BLACK STRIPE
27	WINDSHIELD WIPER CIRC. BRKR. TO W/S WIPER SWITCH	RED	138	FUSE PANEL TO BACK UP LAMP SWITCH	WHITE-PURPLE STRIPE
28	WINDSHIELD WIPER SW. TO WINDSHIELD WIPER MOTOR	BLACK-WHITE STRIPE	139	IGN. SW. "ACC." TERM. TO BATT. TERM. OF CIRCUIT BRKR.	GREEN-YELLOW STRIPE
30	IGN. SW. TO CONSTANT VOLTAGE UNIT & INDICATOR LAMPS	BLACK-GREEN STRIPE	140	BACK UP LAMP SWITCH TO BACK UP LAMP	BLACK-RED STRIPE
31	OIL PRESS. INDICATOR TO OIL PRESS. SENDING UNIT	WHITE-RED STRIPE	141	TWO OR THREE SPD. AXLE SW. TO TWO OR THREE SPD. AXLE MTR.	BLACK-PINK STRIPE
32	IGNITION SWITCH TO STARTER MOTOR RELAY	RED-BLUE STRIPE	142	TWO OR THREE SPEED AXLE CIRCUIT BREAKER LOAD TERM. TO SPEED AXLE TERMINAL	GREEN
33	BATTERY TO HORN RELAY	YELLOW	143	TWO OR THREE SPD. AXLE SW. TO TWO OR THREE SPD. AXLE MTR.	RED
34	HEADLAMP DIMMER SW. TO HIGH BEAM INDICATOR LAMP	GREEN-BLACK STRIPE	144	CIRCUIT BRKR. LOAD TERM. TO NO. 142 SPLICE (2 SPEED AXLE)	GREEN
35	ALTERNATOR REGULATOR "F" TERM. TO ALTERNATOR	ORANGE	145	SPEED ADAPTOR TO NO. 141, NO. 146 SPLICE (2 SPEED AXLE)	BLACK
36	ALTERNATOR REGULATOR TO RECTIFIER TERM.	YELLOW-BLACK STRIPE	146	SHIFT MOTOR TO NO. 141, NO. 145 SPLICE (2 SPEED AXLE)	BLACK
37	LOAD TERM. OF AMMETER TO ALTERNATOR OUTPUT TERM.	BLACK-YELLOW STRIPE	147	SHIFT MOTOR TO NO. 143 SPLICE (2 SPEED AXLE)	RED
38	LOAD THRU AMMETER TO BATTERY	BLACK-RED STRIPE	148	HEADLAMP SW. TO AUTO. TRANS. IND. LAMP	BLACK-BLUE STRIPE
39	TEMP. GAGE TO TEMP. SENDING UNIT	RED-WHITE STRIPE	149	AUX. LAMP CIRCUIT BREAKER LOAD TERM. TO AUX. LAMP FEED	YELLOW
40	BATTERY TO CIGAR LIGHTER	BLUE-WHITE STRIPE	150	BATTERY FEED TO FUSE PANEL	RED
41	WARNING LAMP FEED	BLACK-YELLOW STRIPE	151	SPEED CONTROL ON-OFF SWITCH TO AMPLIFIER	BLUE-BLACK STRIPE
42	SWITCH TO WARNING LAMP	RED-WHITE STRIPE	152	ALT. OUTPUT "A" TERM. TO VOLTAGE REG. "A" TERM.	YELLOW
43	IGN. TERM. OF IGN. SW. TO LOW AIR BUZZER	ORANGE-BLUE STRIPE	153	STARTER MOTOR RELAY TO FLASHER	RED-WHITE STRIPE
44	TURN SIGNAL FLASHER TO TURN SIGNAL SWITCH	BLUE	154	AIR TANK VALVE	RED
45	HOT WATER TEMP. RELAY TO HOT WATER TEMP. SENDING UNIT	YELLOW-RED STRIPE	156	AIR TANK VALVE FEED	BLUE
48	BLIND CIRCUIT TERMINATING IN HARNESS (COLOR OPT.)	BLACK	158	KEY WARNING SWITCH TO BUZZER	BLACK-WHITE STRIPE
49	TURN SIG. SW. TO RIGHT TURN SIG. INDICATOR LAMP	WHITE-BLUE STRIPE	159	DOOR JAMB SWITCH TO BUZZER	RED
50	TURN SIG. SW. TO LEFT TURN SIG. INDICATOR LAMP	GREEN-WHITE STRIPE	160	BUZZER TO WARNING INDICATOR RELAY	WHITE
53	COURTESY LAMP SWITCH TO COURTESY LAMP	BLACK-BLUE STRIPE	161	IGN. SW. (ACC. TERM.) TO EMERG. BRAKE WARNING LAMP	GREEN
54	FUSE PANEL TO COURTESY LAMP SWITCH	GREEN-YELLOW STRIPE	162	EMERG. BRAKE WARNING LAMP TO EMERG. BRAKE SWITCH	GREEN-RED STRIPE
55	CARGO LAMP SW. TO CARGO LAMP	BLACK-RED STRIPE	169	OVER RIDE SWITCH TO 3 x 6 MODULE	BLUE-YELLOW STRIPE
56	WINDSHIELD WIPER SW. TO WINDSHIELD WIPER MOTOR	BLUE	170	CARBURETOR SOLENOID TO 3 x 6 MODULE	BLUE-RED STRIPE
57	GROUND CIRCUIT	BLACK	171	DISABLER SOLENOID TO 3 x 6 MODULE	BLUE-BLACK STRIPE
58	WINDSHIELD WIPER SW. TO WINDSHIELD WIPER MOTOR	WHITE-ORANGE STRIPE	172	THROTTLE ANGLE TO 3 x 6 MODULE	BLUE-WHITE STRIPE
59	HEATED EXTERIOR MIRROR FEED	GREEN-PURPLE STRIPE	173	THIRD GEAR SWITCH TO 3 x 6 MODULE	BLUE-ORANGE STRIPE
60	CONSTANT VOLTAGE UNIT TO GAUGE	BLACK-WHITE STRIPE	174	VACUUM SWITCH TO 3 x 6 MODULE	BLUE-GREEN STRIPE
61	WINDSHIELD WIPER SW. TO WINDSHIELD WIPER MOTOR	YELLOW	175	INDICATOR LAMP TO OVER RIDE SWITCH	BLUE-BROWN STRIPE
63	WINDSHIELD WIPER SW. TO WINDSHIELD WIPER MOTOR	RED	176	INDICATOR LAMP TO 3 x 6 MODULE	BLUE-PURPLE STRIPE
65	WINDSHIELD WIPER SW. TO WINDSHIELD WIPER MOTOR	GREEN	181	FUSE PANEL TO HEATER BLOWER MOTOR	ORANGE
66	AIR SHIFT SWITCH TO DASH LAMP	BLUE	182	AIR COND. CIRC. BRKR. (LOAD TERM) TO THERMOSTAT SW.	BROWN-WHITE STRIPE
67	STOP LAMP SW. TO INDICATOR LAMP	GREEN-WHITE STRIPE	183	AIR COND. CIRC. BRKR. (LOAD TERM) TO A/C BLOWER SW. FEED	BROWN
68	DEFROSTER MOTOR (FEED) TO IGN. SW. ACCY. TERM.	ORANGE-BLACK STRIPE	184	AIR COND. SW. (LOW) TO AIR COND. BLOWER MOTOR	RED
69	COIL TERM. IGN. SW. TO FUEL SOLENOID	RED-GREEN STRIPE	185	AIR COND. SW. (HIGH) TO AIR COND. BLOWER MOTOR	BLACK
71	IGNITION SWITCH TO FUSE PANEL	BLACK	188	CIRCUIT BRKR. TO HEADLAMP SW. "BATT." TERM.	BLACK
72	ENGINE ALARM RELAY (OIL PRESSURE) TO IND. LAMP	GREEN	189	TERM. BLOCK TO CIRCUIT BREAKER	GREEN-YELLOW STRIPE
73	LOW AIR BUZZER TO LOW AIR BUZZER SWITCH	ORANGE-GREEN STRIPE	190	IGNITION SW. ACCY. TERM. TO AIR COND. CIRCUIT BREAKER	YELLOW
74	RELAY "H" TERMINAL TO LAMP (WATER)	GREEN	195	EMERG. BRAKE SW. TO SIGNAL LAMP & RESISTOR GND.	RED
75	STARTER MOTOR RELAY TO SERIES PARALLEL SW. (NO. 1 TERM)	GREEN-RED STRIPE	196	ACCY. FEED FROM FUSE PANEL TO RELAY	RED
76	MARKER LAMP FEED (NON TRACTOR) TO AUX. CIRC. BREAKER	BLACK-GREEN STRIPE	197	AUX. ACCY. FEED FROM RELAY	RED-BLUE STRIPE
78	CIR. BREAKER TO RH & LH MARKER LAMPS	BLUE-YELLOW STRIPE	198	BATT. TERM. OF STARTER SOLENOID TO RELAY	BLACK
79	CONTROL RECTIFIER TO ALT. REG. "IGN." TERM.	GREEN-RED STRIPE	199	CIRCUIT BREAKER FEED	BLACK-ORANGE STRIPE
80	BATTERY TO ENGINE COMPARTMENT LAMP	BLACK-WHITE STRIPE	200	CIRCUIT BREAKER TO SPLICE	BLUE
81	THERMAL SW. TO BLOWER MOTOR CONTROL RLEY	BROWN	201	SPLICE TO HEADLAMP SWITCH	BLUE-YELLOW STRIPE
	HEADLAMP SW. (REAR LAMP) TO SPEEDOMETER LAMP	BLACK	203	INTERIOR LAMP PICKUP BOX COVER	WHITE-YELLOW STRIPE
	WINDSHIELD WIPER/WASHER SW. TO FUSE PANEL	RED	205	CIRC. BRKR. LOAD TERM. TO STOPLAMP WRNG. RELAY	
		GREEN-ORANGE STRIPE		ARM. TERM.	GREEN
		BLACK-WHITE STRIPE	206	GROUND RETURN TO TOWING VEHICLE	WHITE
		ORANGE	207	MARKER LAMP SWITCH TO MARKER LAMPS	BLACK
		GREEN-WHITE STRIPE			
		BLUE			
		BLUE-YELLOW STRIPE			
		WHITE			

100% GUARANTEED

BUY IT NOW!

Click Here To Order

PayPal, American Express, Discover, MasterCard, VISA

STANDARD WIRE COLOR CODE CHART (Continued)

CIRCUIT	DESCRIPTION	COLOR	CIRCUIT	DESCRIPTION	COLOR
208	WATER TEMP. SW. (HOT) TO DELAY & CONTROL RELAY	RED-WHITE STRIPE	374	STARTING MOTOR RELAY TO ENGINE USAGE INDICATOR	RED
209	STOPLAMP SW. TO RELAY	YELLOW	376	HORN BUTTON TO HORN	BLUE-YELLOW STRIPE
210	INDICATOR LAMP TO SWITCH	BLUE	377	AUX. CIRCUIT BRKR. TO HORN BUTTON	YELLOW-BLUE STRIPE
212	AUX. CIRC. FEED TO TRACTOR TRAILER PLUG	BLUE	383	EMERGENCY WARNING FLASHER FEED	RED-WHITE STRIPE
213	OIL LEVEL SENDER TO SIGNAL UNIT (LAMP)	RED	384	FLASHER TO EMERGENCY WARNING LAMP	WHITE-BLUE STRIPE
214	SIGNAL UNIT (LAMP) TO TEMP. SIGNAL LAMP	RED-BLACK STRIPE	385	FLASHER TO EMERGENCY WARNING SWITCH	WHITE-RED STRIPE
215	SIGNAL UNIT (LAMP) TO FUEL SIGNAL RELAY	YELLOW-BLACK STRIPE	386	FLASHER TO EMERGENCY WARNING INDICATOR	YELLOW
221	IGNITION SW. "ACCY. TERM" TO HEATER TEMPERATURE SW. FD.	BLUE	388	AUX. CIRCUIT BREAKER FEED	YELLOW-RED STRIPE
222	TEMPERATURE CONTROL SW. TO HEATER MOTOR BLOWER SW.	RED	399	FUSE PANEL TO HEATER BLOWER SWITCH	BROWN
230	EMISSION CONTROL VALVE TO SWITCH	BROWN-YELLOW STRIPE	400	SAFETY RELAY (LOAD TERM) TO WINDOW REGULATOR SWITCH FEED	BLUE-BLACK STRIPE
231	"L" TERM. VOLTAGE REG. TO ACCESSORY TERM. IGN. SW.	YELLOW-BLACK STRIPE	404	WINDOW REGULATOR SWITCH TO BACK WINDOW SWITCH	PURPLE-GREEN STRIPE
232	ELECTRONIC SW. TO IGN. COIL NEG. TERM.	GREEN-YELLOW STRIPE	405	WINDOW REGULATOR SWITCH TO BACK WINDOW SWITCH	PURPLE-BLUE STRIPE
233	WINDSHIELD WASHER MOTOR TO IGN. SW.	GREEN	407	WINDOW REGULATOR SWITCH REAR TO LIMIT SWITCH	TAN-BLACK STRIPE
234	WINDSHIELD WASHER MOTOR TO IGN. SW.	BLACK	450	IGN. SW. TO SEAT BELT WARNING INDICATOR LAMP FEED	GREEN
235	ALTERNATOR RELAY TO ALTERNATOR REGULATOR	YELLOW-BLACK STRIPE	451	SEAT BELT WARNING LAMP TO SEAT BELT WARNING RELAY	BLACK-RED STRIPE
252	CIRCUIT BREAKER (LOAD) TO 3 SPEED AXLE SWITCH	GREEN	452	IGN. SW. TO SEAT BELT WARNING IND. RELAY	GREEN-WHITE STRIPE
253	INTERMEDIATE TERMINAL 3 SPEED AXLE SWITCH TO SOLENOID VALVE FORWARD TANDEM	RED	453	SEAT BELT WARNING IND. GRD. SW. TO S/B WRNG. IND. RELAY	BLACK-YELLOW STRIPE
254	HIGH TERM. 3 SPEED AXLE SW. TO SOLE. VALVE REAR TANDEM	BLACK	454	IGN. SW. COIL TERM. TO CIRCUIT BREAKER	RED-GREEN STRIPE
255	CIRCUIT BREAKER (LOAD) TO AXLE LOCKOUT DIFFERENTIAL	BLUE	455	CIRCUIT BREAKER TO FUEL VALVE	GREEN-RED STRIPE
256	ACCESSORY TERM IGN. SW. TO 3 SPEED AXLE SWITCH	GREEN	460	BATTERY TO HORN SWITCH	YELLOW
257	IGN. SW. "ACCY. TERM." TO BLOWER MOTOR	YELLOW	469	IGN. SW. ACCY. TERM. TO SEAT BELT WARNING SWITCH	GREEN
258	EMERG. BRAKE WARNING LAMP TO EMERG. BRAKE SWITCH	BLACK	474	IGNITION SW. (ACCY.) TO STOPLAMP RELAY (BATT. TERM.)	RED
259	IGN. SW. TO EMERG. BRAKE WARNING LAMP	BLACK-RED STRIPE	475	STOPLAMP SW. TO STOPLAMP RELAY (COIL TERM.)	GREEN-WHITE STRIPE
260	BLOWER MOTOR TO SWITCH — LOW	RED-BLACK STRIPE	477	CIRCUIT BREAKER TO FOG LAMP SWITCH	BLUE-BLACK STRIPE
261	BLOWER MOTOR TO SWITCH — HIGH	ORANGE-BLACK STRIPE	478	FOG LAMP SWITCH TO FOG LAMP	GRAY
262	STARTER MOTOR RELAY TO IGN. COIL "I" TERM.	BROWN	480	HI LAMP FEED FROM HEADLAMP SWITCH TO FUSE PANEL	YELLOW-ORANGE STRIPE
263	CLICKER RELAY TERM. NO. 4 TO AIR VALVE ASSY.	RED	482	HORN SWITCH TO HORNS	BLACK-YELLOW STRIPE
264	CLICKER RELAY TERM. NO. 3 TO AIR VALVE ASSY.	BLUE	483	INHIBITOR SWITCH TO MAKE READY SWITCH	YELLOW-BLUE STRIPE
265	CLICKER RELAY TERM. NO. 1 TO SPEED CONTROL BRAIN	WHITE	484	CLICKER RELAY TERM. NO. 1 TO RESUME SPEED SWITCH	BLACK
266	BRAKE SW. TO CLICKER RELAY TERM. NO. 4	YELLOW	489	EMERGENCY FLASHER SWITCH TO STOPLAMP RELAY	ORANGE
267	CONTROL HEAD MAKE READY SW. TO BRAKE SW.	BLACK-YELLOW STRIPE	490	IGNITION SWITCH TO TRANSMISSION INDICATOR LAMP	BLUE-RED STRIPE
268	HEATER SW. TO HEATER BLOWER MOTOR (LOW)	RED-BLACK STRIPE	491	CIRC. BREAKER (BATT. TERM) TO STOPLAMP RELAY (BATT. TERM)	RED-WHITE STRIPE
269	HEATER SW. TO HEATER BLOWER MOTOR (MEDIUM)	BLUE-RED STRIPE	492	STOPLAMP RELAY (ARM TERM.) TO TURN SIGNAL SWITCH	GREEN
270	HEATER SW. TO HEATER BLOWER MOTOR (HIGH)	BLACK-YELLOW STRIPE	494	TURN SIGNAL RELAY TO T/S FLASHER	WHITE
271	AIR COND. MASTER SW. TO "F" TERM. OF FAST IDLE RELAY	BLUE	509	AIR COND. CONDENSOR THERMAL SWITCH FEED	YELLOW
272	NEUTRAL SWITCH TO "B" TERM. OF FAST IDLE RELAY	GREEN	510	AIR COND. CONDENSOR THERMAL SW. TO BLOWER MOTOR	ORANGE
273	IGN. SWITCH TO FAST IDLE RELAY	YELLOW	511	STOPLAMP SW. TO TURN SIGNAL SW.	GREEN
274	FAST IDLE RELAY TO STARTING MOTOR RELAY	RED	512	SWITCH TO TRAILER AUX. LAMPS	BLACK
275	FAST IDLE RELAY "A" TERM. TO FAST IDLE SOLENOID	BLACK	513	CIRCUIT BREAKER TO STOPLAMP RELAY FEED	BROWN
276	STARTER MOTOR RELAY TO NEUTRAL SWITCH	YELLOW	514	EMERGENCY WRNG. SW. TO EMERG. WRNG. RELAY COIL TERM.	BLUE
277	BLOWER MOTOR TO SWITCH	GREEN	515	HEATER RESISTOR TO BLOWER MOTOR (HI)	ORANGE
280	COORDINATOR SW. TO WINDSHIELD WIPER MOTOR	WHITE-GREEN STRIPE	517	CIRCUIT BREAKER (LOAD TERM.) TO CONTROL SWITCH (BATTERY TERMINAL)	BLACK-WHITE STRIPE
281	COORDINATOR SW. TO WINDSHIELD WIPER MOTOR	BLUE-BLACK STRIPE	519	GLOW PLUG SW. TO LAMP (FEED)	WHITE
282	TURN SIGNAL SW. TO RH REAR TURN SIGNAL LAMP	GREEN	520	SEAT BELT WARNING LAMP TO WARNING LAMP SWITCH	PURPLE-WHITE STRIPE
283	TURN SIGNAL SW. TO LH REAR TURN SIGNAL LAMP	YELLOW-BLACK STRIPE	526	CIRCUIT BREAKER TO MARKER LAMP SW. FEED	BLACK-WHITE STRIPE
284	BATTERY FEED TO STOPLAMP SWITCH	RED	532	IGNITION SWITCH TO VACUUM SWITCH	ORANGE
285	"R" TERMINAL HEADLAMP SWITCH TO REAR LAMP	BROWN	533	VACUUM SWITCH TO INDICATOR LAMP	BLACK
286	FUEL GAUGE INDICATOR TO TANK SENDING UNIT	ORANGE	536	BLOWER MOTOR RELAY (LOAD TERM) TO BLOWER MOTOR	BLACK
288	"R" TERM. OF ALT. REG. TO ALT. "R" TERM	WHITE-BLACK STRIPE	537	COMPRESSOR TO CLUTCH	YELLOW
289	FAST IDLE RELAY "A" TERM. TO COMPRESSOR CLUTCH	BLACK	546	STARTER CONTROL TO INTERLOCK MODULE	WHITE-PINK STRIPE
292	REAR TERM. OF HEADLAMP SW. TO STORAGE COMPT. LAMP	WHITE	560	SEAT BELT WRNG. TIMER TO L.F. RETRACTOR SWITCH	BROWN-BLUE STRIPE
296	FUSE PANEL ACCY. FEED TO SPLICE	RED	561	SEAT BELT WRNG. TIMER TO R.F. SEAT SENSOR	BLUE-WHITE STRIPE
297	IGN. SW. (ACCY. TERM) TO FUSE PANEL ACCY. FEED	BLACK-GREEN STRIPE	562	SENSOR SIGNAL TO AMPLIFIER	GREEN-WHITE STRIPE
313	WINDOW REGULATOR SWITCH TO WINDOW REGULATOR MOTOR (DOWN)	ORANGE-WHITE STRIPE	563	AUX. HEADLAMP SW. TO AUX. HD. LAMP RELAY	BROWN
314	WINDOW REGULATOR SWITCH TO WINDOW REGULATOR MOTOR (UP)	WHITE-ORANGE STRIPE	564	HEADLAMP SW. TO AUX. HEADLAMP RELAY	ORANGE
331	WINDSHIELD WASHER SW. (FLOOR) TO W/SHIELD WIPER SW.	RED	565	AUX. HEADLAMPS TO AUX. HD. RELAY	BLUE
332	WINDSHIELD WASHER SW. FEED (FLR.) TO IGN. SW. ACCY. TERM	YELLOW	568	ALTERNATOR RELAY TO ALTERNATOR REGULATOR	GREEN
333	WINDOW REGULATOR SWITCH TO WINDOW REGULATOR MOTOR	YELLOW-RED STRIPE	569	INTERLOCK MODULE TO CENTER BUCKLE SWITCH	ORANGE-WHITE STRIPE
334	WINDOW REGULATOR SWITCH TO WINDOW REGULATOR MOTOR	RED-YELLOW STRIPE	570	INTERLOCK MODULE TO CENTER SEAT SENSOR	YELLOW-GREEN STRIPE
345	RELAY NO. 1 TERM. TO POST. TERM. VOLT. REG.	GREEN-WHITE STRIPE	572	ENGINE WARNING SYSTEM	RED-WHITE STRIPE
346	RELAY NO. 2 TERM. TO BATT. TERM. START RELAY	WHITE-GREEN STRIPE	575	LIGHT SWITCH FEED	RED-BLACK STRIPE
347	THERMOSTATIC SW. TO CLUTCH	BLACK	576	LIGHT SWITCH TO RELAY	BLUE
348	THERMOSTATIC SW. TO AIR COND. SW. SELECTOR TERM.	GREEN-WHITE STRIPE	577	FUSE PANEL TO CIRCUIT BREAKER	GREEN
349	THERMOSTATIC SW. TO AIR COND. SW.	BROWN	578	CIRCUIT BREAKER TO RELAY FEED	YELLOW
350	AIR COND. SW. "HI" TERM. TO CLUTCH RELAY "BATT." TERM.	YELLOW	579	RELAY TO JUNCTION BLOCK	BLACK-ORANGE STRIPE
351	CLUTCH RELAY TO CLUTCH	RED	580	FUSE PANEL TO ANTI-SKID	BLUE
352	AIR COND. SW. (ACCY. TERM) TO AIR COND. EVAPORATOR MOTOR SW.	YELLOW	581	FAILURE MODULE TO RELAY	GREEN-WHITE STRIPE
353	COMPRESSOR CLUTCH	BLACK-WHITE STRIPE	583	INTERMITTENT GOV. TO INTERMITTENT GOV. FEED	BLACK
354	CONTROL IND. LAMP	YELLOW-BLUE STRIPE	584	IGN. SW. TO SEAT BELT WARNING IND.	GREEN-BLUE STRIPE
355	BLWR. MOTOR RELAY	BLACK-GREEN STRIPE	587	W/SHIELD WIPER SW. TO INTERMITTENT GOVERNOR FEED	BLACK-WHITE STRIPE
356	WIPER MOTOR	BROWN	588	W/SHLD. WIPER MOTOR DYN. BRAKE TO W/S WIPER SW. GRND.	WHITE-BLACK STRIPE
357	WIPER MOTOR	YELLOW	589	W/SHLD. WIPER SW. TO INTERMITTENT GOV. GRND. DYN. BRKG.	ORANGE
358	WIPER MOTOR	RED	590	INTERMITTENT GOVERNOR TO W/S WIPER SWITCH	BLUE-WHITE STRIPE
359	WIPER MOTOR	YELLOW	591	SPEED CONTROL RELAY TO SPEED REGULATOR	BLACK-ORANGE STRIPE
360	WIPER MOTOR	RED	592	STOPLAMP SW. TO SPEED CONTROL RELAY	BLUE-WHITE STRIPE
361	WIPER MOTOR	YELLOW	593	SPEED CONTROL ACTUATOR TO CUTOFF RELAY	YELLOW

100% SATISFACTION GUARANTEED

BUY IT NOW!

Click Here To Order

STANDARD WIRE COLOR CODE CHART (Continued)

CIRCUIT	DESCRIPTION	COLOR	CIRCUIT	DESCRIPTION	COLOR
594	TEMP. TRANSMITTER TO IND. LAMP (ENGINE COLD)	GREEN	701	C.B. SQUELCH CONTROL	WHITE-PURPLE STRIPE
596	PRIMER SW. TO OIL PRESSURE SAFETY SWITCH	BLACK	702	C.B. PUSH TO TALK	WHITE-BLACK STRIPE
597	COIL TERM. OF IGN. SW. TO OIL PRESSURE SAFETY SW.	RED	703	C.B. DOWN SWITCH	WHITE-ORANGE STRIPE
598	COIL TERM. OF IGN. SW. TO FUEL PUMP PRIMER SWITCH	RED-BROWN STRIPE	704	FRONT RADIO SPEAKER VOICE COIL GROUND	BLACK-RED STRIPE
599	START TERM. OF IGN. SW. TO FUEL PUMP PRIMER SWITCH	RED-BLUE STRIPE	705	CIRCUIT BREAKER TO HEATER BLOWER SWITCH	BROWN
600	FAILURE MODULE TO TANDEM RR. AXLE CONTROLLER	BLUE-BLACK STRIPE	706	C.B. SCAN L.E.D.	GRAY
601	BRAKE SKID CONTROL MODULE FEED	BLUE	707	C.B. UP SWITCH	WHITE-YELLOW STRIPE
602	COIL TERM. OF IGN. SW. TO BRAKE SKID CONTROL MODULE	RED-PURPLE STRIPE	708	RADIO SPEAKER VOICE COIL FEED	BLACK-ORANGE STRIPE
603	DUAL BRAKE WARNING LIGHT TO BRAKE SKID CONTROL MODULE	GREEN	709	C.B. VOLUME CONTROL	WHITE-BLUE STRIPE
604	SKID CONTROL MODULE TO R.H. WHEEL SENSOR (HIGH)	YELLOW	710	C.B. SCAN SWITCH	WHITE-GREEN STRIPE
605	SKID CONTROL MODULE TO R.H. WHEEL SENSOR (LOW)	BROWN	711	C.B. REGULATED 5V	GREEN-BLACK STRIPE
606	SKID CONTROL MUDULE TO L.H. WHEEL SENSOR (HIGH)	YELLOW	712	C.B. A-DIGIT	PURPLE
607	SKID CONTROL MODULE TO L.H. WHEEL SENSOR (LOW)	BROWN	713	C.B. MIC-AUDIO	WHITE
608	FAILURE MOD. TO FRONT AXLE CONTROL	BLUE-WHITE STRIPE	714	C.B. C-DIGIT	ORANGE
609	ESOTP MODULE TO THERMOCOUPLE (NEG.)	RED	715	C.B. A-DIGIT	GREEN
610	THERMOCOUPLE (-) MODULE TO SENSOR	RED-YELLOW STRIPE	716	C.B. B-DIGIT	YELLOW
611	THERMOCOUPLE (+) MODULE TO SENSOR	YELLOW	717	C.B. SPEAKER TO TRANCEIVER	BLUE-RED STRIPE
612	AIR DUMP VALVE (-) TO MODULE	BLUE	718	C.B. ON/OFF	RED-WHITE STRIPE
613	EGR VALVE (-)	BROWN	719	C.B. NOISE BLANKER	GREEN-ORANGE STRIPE
614	SPEED SENSOR	GREEN	720	C.B. B-DIGIT	BLUE
615	FEED TO FAILURE SWITCH	BLACK-YELLOW STRIPE	721	C.B. SPEAKER VOICE COIL RETURN	BLUE-GREEN STRIPE
617	FUSE PANEL TO SKID CONTROL MODULE	BLACK-GREEN STRIPE	722	C.B. RELAY DRIVE	GREEN-RED STRIPE
618	FAILURE MOD. TO RR. AXLE CONTROL	RED	723	C.B. SPEAKER RELAY TO MIC	BLUE-ORANGE STRIPE
619	FAILURE MOD. TO RR. AXLE CONTROL	GREEN-YELLOW STRIPE	724	C.B. C-DIGIT	GREEN-WHITE STRIPE
620	FAILURE MOD. TO RR. AXLE CONTROL	BLUE	725	C.B. D-DIGIT	BROWN
621	FAILURE MOD. TO FRONT AXLE CONTROL	GREEN	730	BATTERY TO VOLT METER	RED
622	FAILURE MOD. TO FRONT AXLE CONTROL	RED-WHITE STRIPE	732	DISTRIBUTOR ELECTRONIC CONTROL FEED	WHITE
625	IGNITION SW. COIL TERM. TO PRIMER SWITCH	BLUE	733	AMPLIFIER GROUND BREAKERLESS MODULE TO DISTRIBUTOR	BLACK-GREEN STRIPE
629	FAILURE MOD. TO RR. AXLE CONTROL	RED-BLACK STRIPE	734	AMPLIFIER TO SERVO TRANSDUCER FEED	ORANGE-YELLOW STRIPE
630	FUSE PANEL TO FAILURE INDICATOR RELAY	WHITE	735	AMPLIFIER FEEDBACK POTENTIOMETER FEED	PURPLE-BLUE STRIPE
631	FAILURE MOD. TO TAN. RR. AXLE CONTROL	GREEN-BLACK STRIPE	737	AIR CONDITIONER MOTOR TO GROUND	GREEN
632	IGN. SW. COIL TERM. TO OIL TEMP. WARNING LAMP	BLACK	738	FUEL PUMP RELAY "H" TERMINAL TO OIL PRESSURE SWITCH	GREEN-ORANGE STRIPE
633	IGN. SW. TO OIL TEMP. WARNING RELAY	RED	739	FUEL PUMP RELAY TO SELECT SWITCH "B" TERMINAL	RED-YELLOW STRIPE
634	OIL TEMP. WARNING RELAY TO OIL TEMP. WARNING LAMP	BLUE	740	IGNITION SWITCH (COIL TERM.) TO FUEL PUMP RELAY	GREEN
635	OIL TEMP. WARNING LAMP TO OIL TEMP. WARNING SWITCH	GREEN	741	IGNITION SWITCH (ACCY. TERM.) TO FUEL PUMP RELAY	RED
636	OIL TEMP. WARNING RELAY TO OIL TEMP. SW.	GREEN	742	FUEL PUMP RELAY TO FUEL PUMP	BLUE
637	OIL TEMP. WARNING RELAY TO FLASHER	BLACK	743	FUEL PUMP RELAY TO OIL PRESSURE SW.	YELLOW
638	FLASHER TO OIL PRESS. SWITCH	YELLOW	747	FUSE PANEL TO RADIO RECEIVER	BLACK
639	FLASHER TO OIL TEMP. WARNING LAMP	YELLOW-RED STRIPE	748	A/C MODE SHIFT TO HEATER CONTROL SWITCH	BLUE
640	IGN. SWITCH COIL TERM. TO WARNING LAMPS	RED-YELLOW STRIPE	749	RADIO RECEIVER TO F.M. TUNER FEED	BLACK
641	IGN. SWITCH GROUND TERM. TO WARNING LAMP	BLACK-RED STRIPE	753	HEATER & A/C CONTROL SWITCH TO BLOWER RELAY SWITCH	YELLOW-RED STRIPE
642	WATER TEMP. WARNING LAMP TO WATER TEMP. SW. (COLD)	WHITE-GREEN STRIPE	763	ACC. TERM. OF IGN. SW. TO W/S WIPER CIRCUIT BREAKER	ORANGE-WHITE STRIPE
643	CHARGE INDICATOR LAMP TO SPLICE	YELLOW-BLACK STRIPE	764	W/S WIPER CIRCUIT BREAKER TO W/S WIPER MOTOR	BLACK-ORANGE STRIPE
644	OIL TEMP. WARNING LAMP TO IGN. SWITCH (ACCY. TERM.)	RED-GREEN STRIPE	778	SEAT BELT SW. FEED. "P" TERM.	YELLOW
645	IGNITION SWITCH COIL TERMINAL TO TACHOMETER	BLACK	779	MARKER LAMP SWITCH TO BLINK SWITCH	WHITE-BLACK STRIPE
646	TACH. THRU IGN. RESISTOR TO BATTERY TERM. OF IGN. COIL	RED	780	ENGINE ALARM RELAY (OIL PRESS.) "F" TERM. TO "A" TERM. IGNITION SWITCH	RED
647	WATER TEMP. WARNING LAMP TO WATER TEMP. SWITCH (HOT)	RED	781	BRAKE PAD SWITCH TO HOLDING RELAY	BROWN
648	IGNITION SW. COIL TERMINAL TO TACHOMETER	RED	784	STEREO SPEAKER VOICE COIL RETURN	PURPLE
649	TACHOMETER TO IGNITION COIL "B" TERM.	RED-GREEN STRIPE	786	FUEL PUMP PRIMER SW. TO FUEL PUMP RELAY	RED
654	ALT. SHUNT "A" TERM. TO AMMETER	YELLOW-BLACK STRIPE	787	FUEL PUMP SAFETY SWITCH TO FUEL PUMP MOTOR	RED-BROWN STRIPE
655	STARTER MOTOR RELAY SHUNT TO AMMETER	RED-ORANGE STRIPE	789	VACUUM SWITCH TO HOLDING RELAY	BROWN-WHITE STRIPE
666	DOME LAMP FEED	RED	795	NEUTRAL SAFETY RELAY TO NEUTRAL SWITCH	RED-BLACK STRIPE
668	IGN. RELAY TO STARTER MOTOR RELAY	BLACK	796	ACCESS. FEED TO NEUTRAL SAFETY RELAY	BLACK
669	IGN. RELAY TO STARTER MOTOR RELAY STARTER TERM.	RED-BLUE STRIPE	797	BATTERY FEED TO STEREO	GREEN
670	FAILURE INDICATOR TO MODULE	PINK	802	SPEAKER VOICE COIL FEED-FRONT (LEFT CHANNEL)	BLUE
671	SPEED REG. SW. "ON" POSITION TO ON & OFF RELAY	WHITE	803	SPEAKER VOICE COIL FEED-FRONT (RIGHT CHANNEL)	RED
672	SELECTOR SW. TO LEFT HAND PUMP MOTOR	BROWN	804	FADER CONTROL TO FADER ARM (LEFT CHANNEL)	RED
673	SELECTOR SW. TO LEFT FUEL GAUGE	GREEN	805	FADER CONTROL TO FADER ARM (RIGHT CHANNEL)	BLUE
674	SELECTOR SW. TO RIGHT HAND PUMP MOTOR	BROWN-WHITE STRIPE	806	SPEAKER VOICE COIL FEED (RIGHT CHANNEL)	WHITE
675	SELECTOR SW. TO RIGHT FUEL GAUGE	GREEN-RED STRIPE	807	SPEAKER VOICE COIL FEED (LEFT CHANNEL)	ORANGE
676	L.H. SENSOR FEED JUNCTION BLOCK TO CONTROLLER	ORANGE	808	SELECTOR SWITCH TO FUEL TANK SOLENOID VALVE	BROWN-ORANGE STRIPE
677	L.H. SENSOR COMMON JUNCTION BLOCK TO CONTROLLER	GREEN	809	STOPLAMP SWITCH TO STOPLAMP	RED-BLACK STRIPE
678	R.H. SENSOR COMMON JUNCTION BLOCK TO CONTROLLER	GREEN-WHITE STRIPE	810	STOPLAMP SWITCH TO STOPLAMP	RED-BLACK STRIPE
679	R.H. SENSOR FEED JUNCTION BLOCK TO CONTROLLER	ORANGE-WHITE STRIPE	811	RELAY "A" TERM. TO TRAILER TAIL LAMPS	BROWN
680	SELECTOR SWITCH TO MIDSHIP FUEL TANK	BLUE	812	MARKER LAMP SWITCH TO MIRROR LAMP	BLUE
682	H/L SW. BATT. TERM. TO TRACTOR — TRAILER RELAY "B" TERM.	YELLOW	813	BRAKE SWITCH TO TRAILER RELAY "B" TERM.	YELLOW-BLACK STRIPE
683	H/L SW. "R" TERM. TO TRACTOR — TRAILER RELAY "F" TERM.	BROWN	814	IGN. SWITCH COIL TERM. TO VOLTAGE RELAY	WHITE
684	TRACTOR — TRAILER RELAY "A" TERM. TO MARKER LAMP SW.	BLACK-WHITE STRIPE	816	CIRCUIT BREAKER TO REVERSE RELAY FEED	YELLOW-BLUE STRIPE
685	TRACTOR — TRAILER RELAY CIRC. BRKR. TO AUX. MARKER LAMP SW.	BLACK-RED STRIPE	822	FRONT SPEAKER TO FADER CONTROL SWITCH	BROWN
687	ACCESSORY FEED	GRAY-YELLOW STRIPE	823	FADER CONTROL SWITCH TO RADIO	GREEN
688	WATER TEMP. WARNING LAMP TO WATER TEMP. SWITCH (HOT)	GRAY-BLUE STRIPE	824	FRONT SPEAKER TO RADIO	BLUE
689	SPEED REG. SW. "ON" POSITION TO ON & OFF RELAY	PURPLE	825	SERVO SOURCE VACUUM SOLE TO CONTROL TRANSISTOR	GRAY-BLACK STRIPE
690	FAILURE MOD. TO RR. AXLE CONTROL	GREEN-WHITE STRIPE	826	SERVO VENT VACUUM SOLE TO CONTROL TRANSISTOR	WHITE-PINK STRIPE
691	FAILURE MOD. TO RR. AXLE CONTROL	YELLOW	827	SERVO FEEDBACK POTENTIOMETER SIGNAL TO AMPLIFIER	YELLOW-RED STRIPE
692	FAILURE MOD. TO RR. AXLE CONTROL	BROWN	828	SERVO FEEDBACK POTENTIOMETER BASE TO AMPLIFIER	BROWN-GREEN STRIPE
693	FAILURE MOD. TO RR. AXLE CONTROL	BROWN	829	IGN. SW. (ACCY. TERM.) TO VACUUM SOLENOID	RED
694	FAILURE MOD. TO RR. AXLE CONTROL	BROWN	830	SENSOR SIGNAL TO AMPLIFIER	GREEN-WHITE STRIPE
695	FAILURE MOD. TO RR. AXLE CONTROL	BROWN	832	CONTROL RELAY TO HOLDING RELAY	YELLOW-BLACK STRIPE
696	FAILURE MOD. TO RR. AXLE CONTROL	BROWN	833	IGN. SW. ACCY. TERM. TO EMERGENCY STOP LAMP SW.	GREEN
697	FAILURE MOD. TO RR. AXLE CONTROL	ORANGE-BLACK STRIPE	834	REAR SPEAKER VOICE COIL FEED (RIGHT CHANNEL)	BLUE

100% GUARANTEED

BUY IT NOW!

Click Here To Order

PayPal Discover American Express MasterCard VISA

STANDARD WIRE COLOR CODE CHART (Continued)

CIRCUIT	DESCRIPTION	COLOR	CIRCUIT	DESCRIPTION	COLOR
835	REAR SPEAKER VOICE COIL FEED (LEFT CHANNEL)	RED	908	STARTER MOTOR RELAY TO LOCK IN COIL	YELLOW
836	INDICATOR LAMP TO FLASHER	RED	910	BRAKE SWITCH TO AIR VALVE	BLUE-WHITE STRIPE
837	FLASHER TO EMERGENCY BRAKE SWITCH	BLACK	911	FUSE PANEL (ACCY. FEED) TO SPEED REGULATOR SWITCH	ORANGE-WHITE STRIPE
838	THERMAL RELAY TO LOCK IN VALVE	ORANGE-BLACK STRIPE	912	SPEED REGULATOR SWITCH TO SELECTOR SWITCH	YELLOW
839	BATTERY TO STOP LAMP CIRCUIT BREAKER	WHITE	913	HEATER RESISTOR TO BLOWER MOTOR (HI)	YELLOW
847	STARTER RELAY SOLENOID "SM" TERM. TO C.S. RELAY COIL	WHITE	914	FUSE PANEL TO SPEED REG. SW. FEED	GREEN
848	BALLAST RESISTOR "E" TERM. TO TRANSISTOR UNIT "E" TERM.	RED-WHITE STRIPE	915	SPEED REG. BRAKE SW. TO SPEED REG. COIL	BLACK-ORANGE STRIPE
849	STARTER MOTOR RELAY TO TACH BLOCK	BROWN	916	SPEED REG. COIL TO AUTOMATIC CONTROL	RED
850	BALLAST RESISTOR COIL TERM. TO IGN. COIL BATT. TERM.	BLUE-WHITE STRIPE	918	IGN. SW. TO TRANS. NEUTRAL SW.	GREEN
851	TRANSISTOR UNIT "B" TERM. TO DISTRIBUTOR	GREEN	919	TRANS. NEUTRAL SW. TO INDICATOR LAMP	BLUE
852	TRANSISTOR "C" TERM. TO BALLAST RESISTOR "C" TERM.	BLUE	920	BRAKE SW. TO SPEED CONTROL REG.	YELLOW
853	COIL TERM. IGN. SW. TO BALLAST RESISTOR "E" TERM.	RED-GREEN STRIPE	921	SPEED CONTROL "OFF POSITION" TO SPEED REGULATOR	GREEN-PURPLE STRIPE
854	C.S. RELAY TO STARTER SOLENOID "I" TERM.	BROWN	922	SPEED CONTROL "ON POSITION" TO SPEED REGULATOR	WHITE
855	TRANSISTOR UNIT TO PICK-UP COIL	PURPLE	923	SPEED CONTROL SW. TO SPEED REG. SOLENOID	PURPLE
856	PICK-UP COIL TO TRANSISTOR UNIT	ORANGE	924	HOLDING RELAY TO SPEED CONTROL SW. FEED	RED
857	TRANSISTOR UNIT TO START TERM. TO STARTER RELAY	WHITE	925	SPEED CONTROL SW. TO SPEED REG. COUPLING COIL	WHITE-ORANGE STRIPE
858	MAKE READY SWITCH TO BRAKE PEDAL PAD SWITCH	RED	926	HEATER BLOWER MOTOR SW. TO BLOWER MOTOR MED.	RED-BLUE STRIPE
859	BRAKE PEDAL PAD SWITCH TO CONTROL RELAY TERM. NO. 4	YELLOW	931	SPEED CONTROL SWITCH TO SPEED REG.	BLACK
860	MAKE READY SWITCH TO SET SPEED SWITCH	PURPLE-WHITE STRIPE	932	IGN. SWITCH TO THROTTLE SOLENOID	BLACK
861	RETARD SWITCH TO CONTROL RELAY TERM. NO. 7	BLUE-WHITE STRIPE	933	EMISSION MODULATOR CONTROL FEED	RED
862	RESUME SWITCH TO CONTROL RELAY TERM. NO. 8	WHITE-BLUE STRIPE	934	EMISSION SPEED SENSOR TO MODULATOR CONTROL	BLUE
863	BRAKE SWITCH TO HOLDING RELAY	BLACK-YELLOW STRIPE	935	TRANSISTOR BASE TERM. TO DIST. TERM. OF IGN. COIL	BLUE
864	BRAKE SWITCH TO 20 M.P.H. SWITCH	ORANGE	936	TRANSISTOR EMITTER TERM. TO TRANSISTOR TERM. OF IGN. COIL	BLACK
865	SELECTOR SWITCH TO WARNING LAMP (LOW OIL PRESSURE)	BLACK	937	EMISSION SPEED SENSOR GROUND	BLACK
866	CONTROL SWITCH TO OIL PRESSURE PUMP	BLACK	939	MODULATOR TO THERMO SWITCH	GRAY
867	IGNITION SWITCH TO OIL PRESSURE SWITCH	RED	941	WASHER CONTROL SW. TO WASHER PUMP MOTOR FEED	BLACK-WHITE STRIPE
868	OIL PRESSURE SWITCH TO CONTROL SWITCH	RED-BROWN STRIPE	943	TRACTOR TRAILER RELAY TO TRACTOR TRAILER CIRC. BRKER. LOAD TERM.	GREEN
869	RETARD VALVE TO CONTROL RELAY TERM. NO. 1	GREEN-YELLOW STRIPE	948	FLASHER TO R.H. LAMP	ORANGE
870	EMERGENCY STOPLAMP SWITCH TO TRACTOR — TRAILER PLUG	BLACK-WHITE STRIPE	949	FLASHER TO L.H. LAMP	BLUE
871	LOCK-IN VALVE TO CONTROL RELAY TERM. NO. 2	RED-WHITE STRIPE	950	FUSE PANEL TO WASHER CONTROL SWITCH	WHITE-BLACK STRIPE
872	STARTER MOTOR RELAY TO CONTROL RELAY TERM. NO. 11	RED-BLUE STRIPE	951	WASHER CONTROL SW. TO WASHER PUMP MOTOR FEED	GREEN-BLACK STRIPE
873	HEADLAMP SWITCH "R" TERM. TO ASH RECPT. LAMP FEED	WHITE-BLACK STRIPE	952	BATTERY TO TRACTOR TRAILER CIRC. BREAKER BATT. TERM.	YELLOW-BLUE STRIPE
876	HEADLAMP SW. BATT. TERM. TO ALT. "A" TERM.	YELLOW	953	COORDINATOR SW. TO W/SHIELD WIPER MOTOR	WHITE-ORANGE STRIPE
877	ALT. "F" TERM. TO REG. "F" TERM.	WHITE	954	W/SHIELD WIPER SW. TO COORDINATOR SW. FEED	BLACK-WHITE STRIPE
878	REG. "A" TERM. TO IGN. SW. COIL TERM.	GREEN	955	W/SHIELD WIPER MOTOR ARM RH TO W/S WIPER SWITCH	RED-ORANGE STRIPE
879	BLOWER SW. MED. NO. 1 THRU RESISTOR TO HI BLOWER MOTOR FIELD	BLACK-ORANGE STRIPE	956	W/SHIELD WIPER SW. TO W/SHIELD WIPER MOTOR FIELD RH	GREEN-ORANGE STRIPE
880	BLOWER SW. MED. NO. 2 TO LOW BLOWER MOTOR FIELD	BLACK-RED STRIPE	957	W/SHIELD WIPER SWITCH FEED TO IGN. SWITCH	YELLOW
881	20 MPH SWITCH TO CONTROL RELAY TERMINAL NO. 16	GRAY	958	ACCY. TERMINAL IGN. SW. TO WASHER CONTROL SW.	WHITE
882	A/C BLOWER SW. TO A/C REFRIGERANT SOL. FEED	WHITE	960	AUX. HEATER FEED TO SWITCH	RED
883	CIRCUIT BREAKER TO A/C CONTROL RELAY	ORANGE	961	GLOW PLUG SW. TO GLOW PLUG WARNING LAMP	BLACK-WHITE STRIPE
884	A/C CONTROL RELAY TO A/C SW. (FEED)	YELLOW	962	DIFF. TEMP. SW. TO FRONT DIFFERENTIAL	RED
885	ACCY. TERM. IGN. SW. TO A/C CONTROL RELAY	WHITE	963	DIFF. TEMP. TO REAR DIFFERENTIAL	GREEN
886	LAMP TO SENDING UNIT	BLUE	964	ALT. TO REG. FIELD CONTROL	BLUE
887	SPLICE TO OIL TEMP. ENG.	RED	965	RELAY (BATT. TERM.) TO BATT. CUT-OFF SWITCH	BLACK
888	W/SHIELD WIPER SWITCH TO RELAY	RED	968	AXLE TEMPERATURE GAUGE TO SELECTOR SWITCH	WHITE-RED STRIPE
889	W/SHIELD WIPER SWITCH TO RELAY	GREEN	970	SELECTOR SWITCH TO FORWARD REAR AXLE SENDING UNIT	RED-WHITE STRIPE
890	W/SHIELD WIPER SWITCH TO RELAY	YELLOW	971	SELECTOR SWITCH TO REAR AXLE SENDING UNIT	WHITE-PURPLE STRIPE
891	W/SHIELD WIPER MOTOR TO RELAY	YELLOW-BLACK STRIPE	973	BATTERY FEED TO FUEL CONTROL VALVE	RED
892	W/SHIELD WIPER SWITCH TO RELAY	BLUE	974	FUEL CONTROL SWITCH TO FUEL CONTROL VALVE	ORANGE
893	W/SHIELD WIPER MOTOR TO RELAY	BLUE-ORANGE STRIPE	975	TRANSMISSION TEMPERATURE LAMP INDICATOR FEED	RED-GREEN STRIPE
895	IGN. SW. TO W/SHIELD WIPER MOTOR CIRCUIT BREAKER	RED	976	FUSE PANEL TO FUEL GAUGE INDICATOR	BLACK-GREEN STRIPE
896	IGN. SW. COIL TERM. TO IND. LAMPS, OIL PRESS. & WATER TEMP.	BLACK	977	BRAKE WARNING SWITCH TO INDICATOR LAMP	PURPLE-WHITE STRIPE
897	CONTROL RELAY TO THERMAL RELAY	RED	978	TRANSMISSION TEMPERATURE GAUGE TO SENDER	YELLOW
898	BRAKE SWITCH TO VACUUM SWITCH	GREEN	984	MARKER LAMP SWITCH TO MARKER LAMP	BROWN
899	ALTERNATOR NEU. TERM. TO ALT. REG. (NEU.-TERM.)	RED	985	TURN SIGNAL RELAY TO LEFT TURN SIGNAL SWITCH	RED
900	ALTERNATOR AUX. TERM. TO IGN. SW. ACCY. TERM.	RED-GREEN STRIPE	986	TURN SIGNAL RELAY TO RIGHT TURN SIGNAL SWITCH	BROWN
901	ALTERNATOR AUX. TERM. TO CHARGE IND. LAMP	YELLOW-BLACK STRIPE	987	TURN SIGNAL RELAY TO LEFT TURN CANCEL SWITCH	RED-BLUE STRIPE
902	ALTERNATOR RECTIFIER (+TERM.) TO LOAD	BLACK-YELLOW STRIPE	988	TURN SIGNAL RELAY TO RIGHT TURN CANCEL SWITCH	BROWN-BLUE STRIPE
903	ALTERNATOR AUX. TERM. TO ALT. REG. FIELD FEED TERM.	GREEN-RED STRIPE	990	RELAY TO INDICATOR LAMP	BLACK-YELLOW STRIPE
904	IGNITION SWITCH (COIL/ACCY.) TO ALT. REG. (IGN. TERM.)	GREEN-RED STRIPE	993	INTERMITTENT GOVERNOR TO WINDSHIELD WIPER SWITCH	BROWN-WHITE STRIPE
905	AIR COND. SW. "MED." TO BLOWER MOTOR	BLUE	994	ELECTRIC COOLING P.V.S. SWITCH	YELLOW
906	IGN. SW. (ACCY. TERM.) TO CIRCUIT BREAKER	BLACK-YELLOW STRIPE	995	HEADLAMP SWITCH TO LO-BEAM OF HEADLAMP	RED-BLACK STRIPE
907	HOLDING RELAY TO 25 MPH SW.	BLACK-ORANGE STRIPE	996	HEADLAMP SWITCH TO WORKLAMP	YELLOW-BLACK STRIPE
			997	IMPLEMENT LAMP SW. TO IMPLEMENT LAMP	BROWN-YELLOW STRIPE
			998	HEADLAMP SWITCH TO HI-BEAM OF HEADLAMP	GREEN-BLACK STRIPE



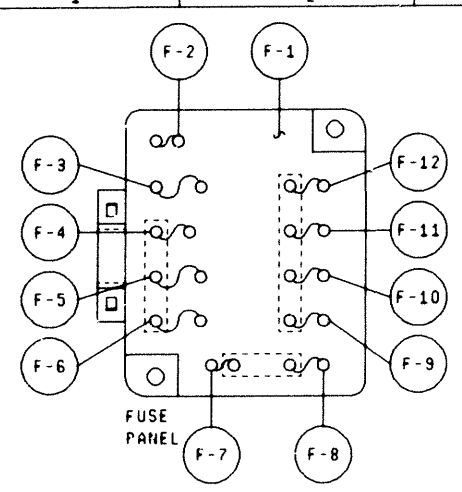

- F1 BLANK
- F2 (13 AMP) PRNDL LAMP, CLUSTER & PANEL ILLUM
- F3 (135 AMP) HEATER OR A/C
- F4 (17.5 AMP) SEAT BELT
- F5 (17.5 AMP) EMISSION SOLENOID
- F6 BLANK
- F7 (15 AMP) DOME, CARGO, COURTESY, GLOVE & UNDERHOOD LAMPS, CIGAR LIGHTER
- F8 (20 AMP) EMERGENCY WARNING FLASHER, STOP LAMPS
- F9 (15 AMP) TURN SIGNAL FLASHER
- F10 (20 AMP) ACCESSORY FEEDS, SPEED CONTROL HEATED BACKLIGHT RELAY, MARKER LAMP RELAY, DUAL BATTERY RELAY, AXLE CONTROL 4 WHEEL DRIVE INDICATOR LAMP
- F11 (15 AMP) BACK-UP LAMPS, WINDSHIELD WASHER PUMP
- F12 (17.5 AMP) RADIO

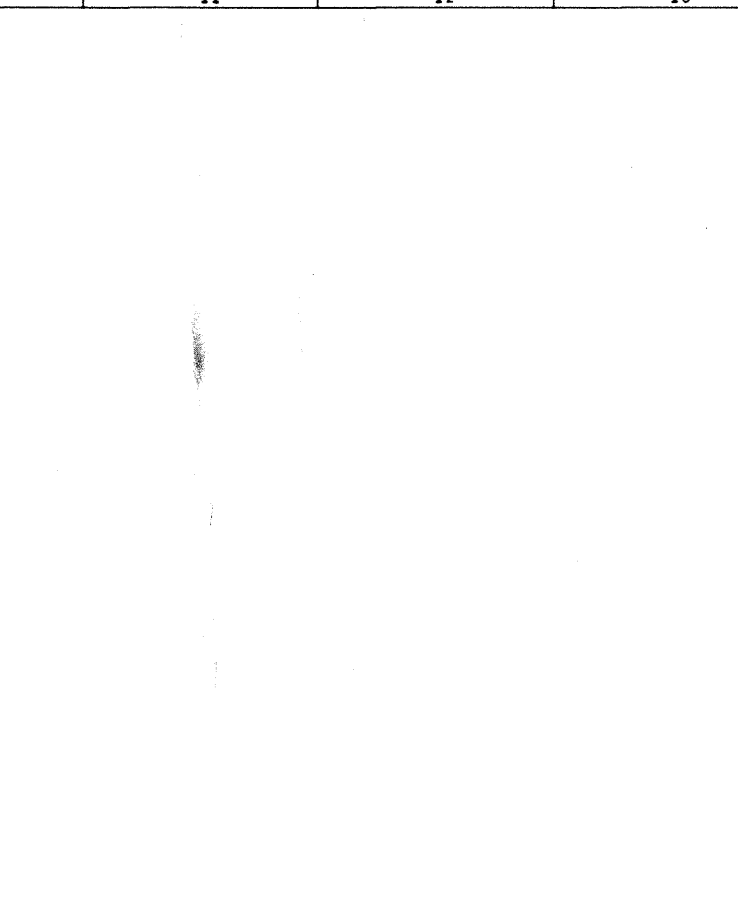
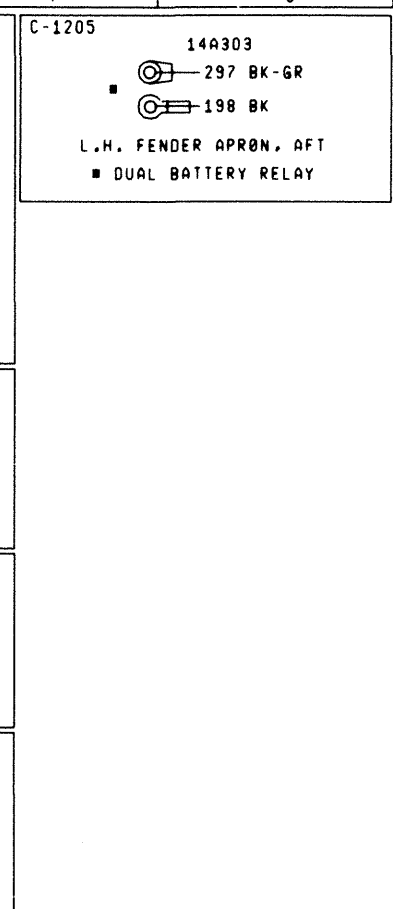
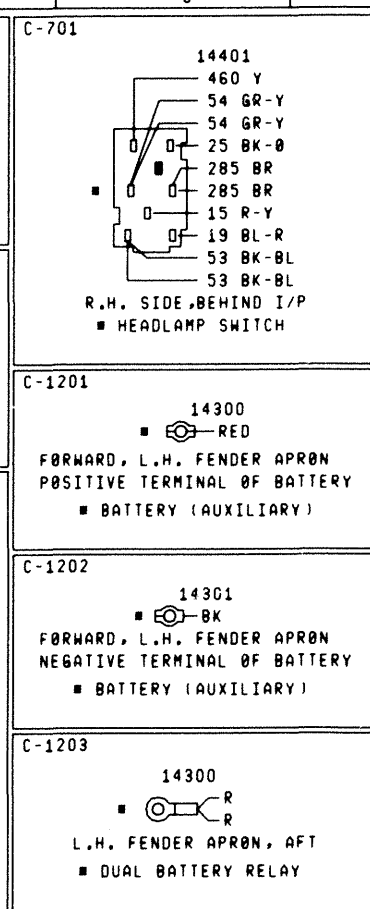
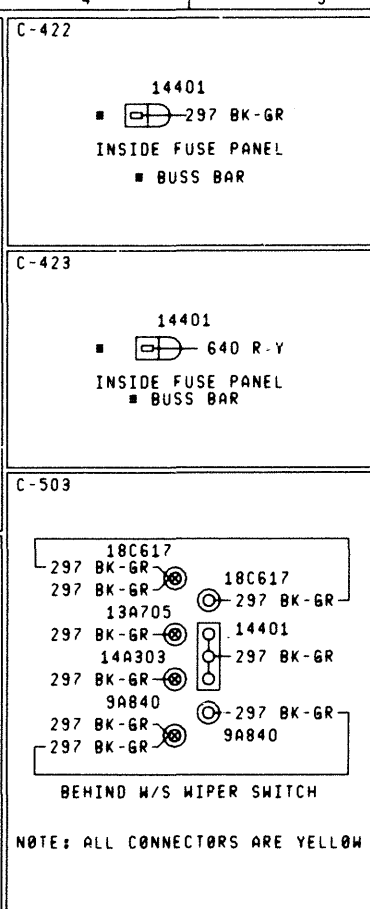
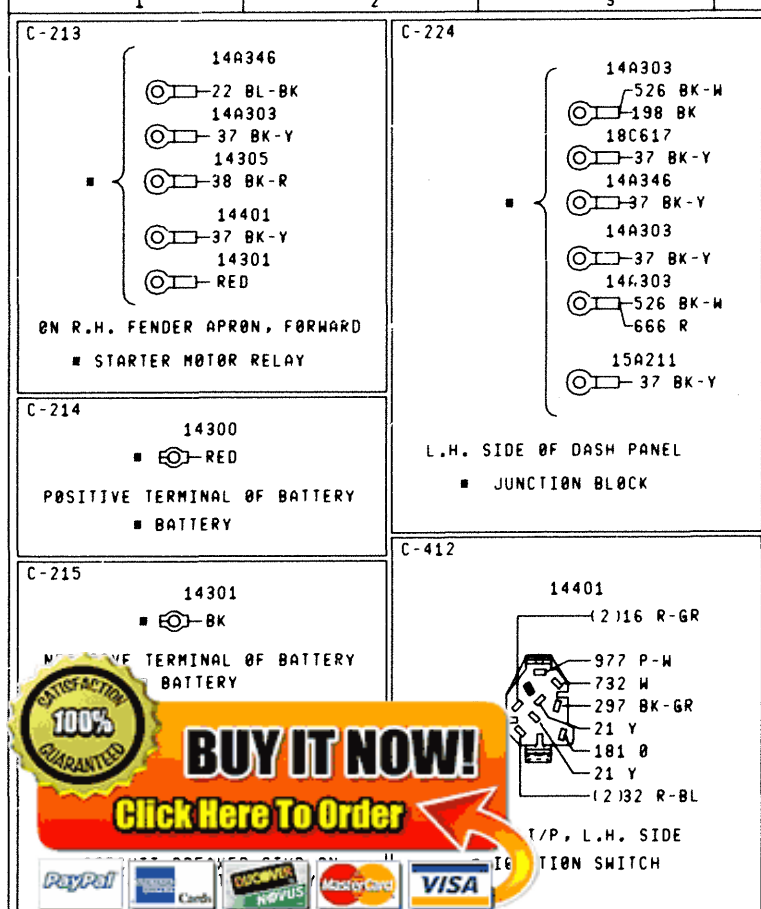
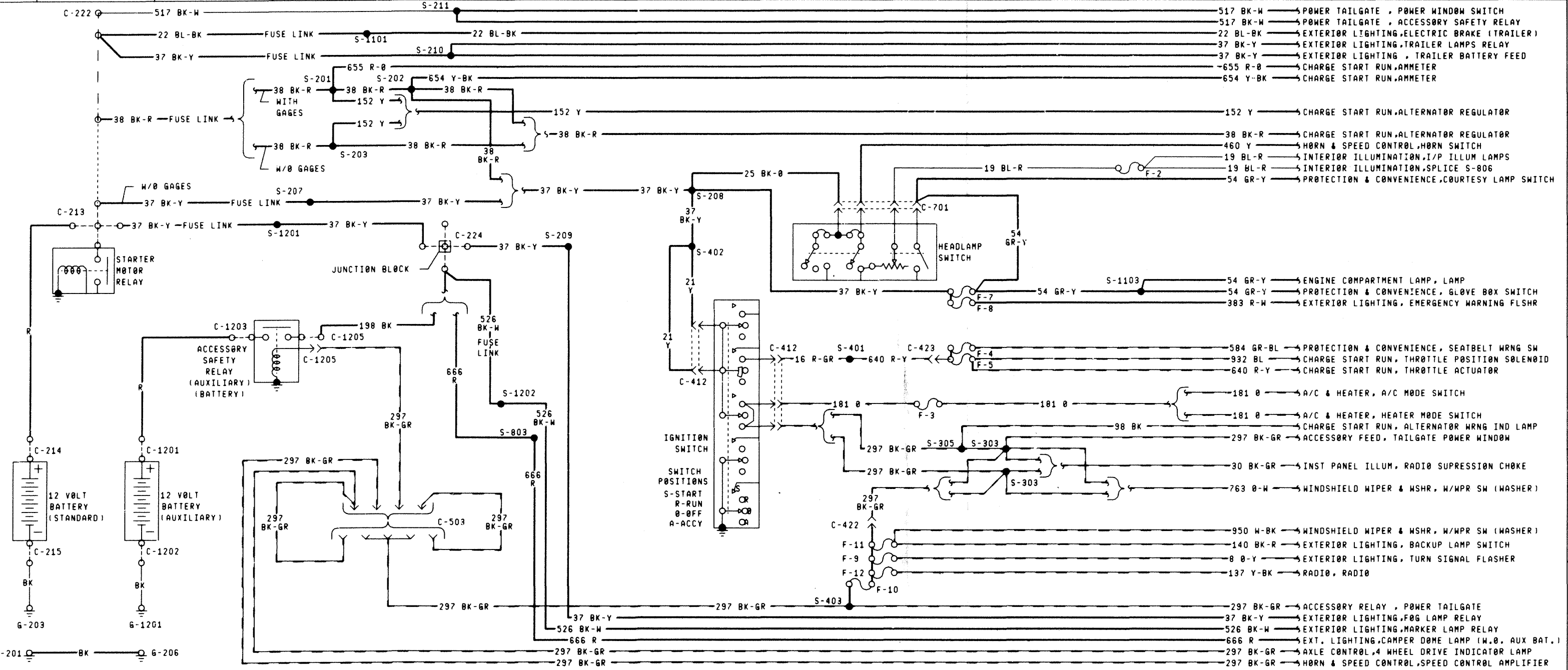

GROUND CODES	
G-201	EYELET ATTACHED TO ENGINE
G-203	BATTERY CABLE ATTACHED TO R.H. FENDER APRON
G-206	EYELET, ON DASH PANEL, LEFT OF CENTER
G-1201	EYELET, IN ENGINE COMPARTMENT, L.H. SIDE, ON DASH PANEL

SPLICE CODES	
S-201	IN 14305 NEAR STARTER MOTOR RELAY
S-202	IN 14305 NEAR STARTER MOTOR RELAY
S-203	IN 14305 NEAR STARTER MOTOR RELAY
S-207	IN 14401, NEAR STARTER MOTOR RELAY
S-208	IN 14401 NEAR T/O TO IGNITION SWITCH
S-209	IN 15A211 NEAR JUNCTION BLOCK
S-210	IN 14A303 NEAR STARTER MOTOR RELAY
S-211	IN 14401, NEAR T/O TO HEATER BLWR MTR RESISTOR
S-303	IN 14401, BEHIND CLUSTER
S-305	IN 14401, NEAR T/O TO IGNITION SWITCH
S-401	IN 14401, NEAR IGNITION SWITCH
S-402	IN 14401, NEAR T/O TO ASH TRAY ILLUMINATION
S-403	IN 14401, MAIN BODY NEAR FUSE PANEL
S-803	IN 14405 NEAR LICENSE LAMP T/O
S-1101	IN 14A346, NEAR STARTING MOTOR RELAY
S-1103	IN 14401, NEAR GLOVE BOX T/O
S-1201	IN 14A303, NEAR STARTER MOTOR RELAY
S-1202	IN 14A303, NEAR STARTER MOTOR RELAY

ELECTRICAL SYSTEMS 1978 BRANCO POWER DISTRIBUTION	
EFFECTIVE P.C.R. SUPERSEDES	TRPO ELECT INST MAN PAGE E8T-900-1
DATE 7-21-77	SERVICE AND TRAINING MAN PAGE 1

100% SATISFACTION GUARANTEED

BUY IT NOW!

Click Here To Order

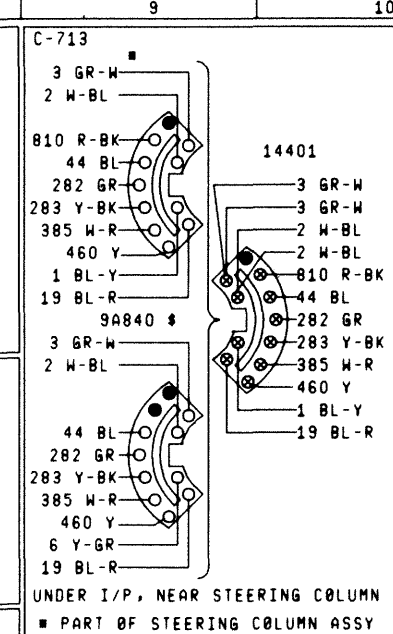
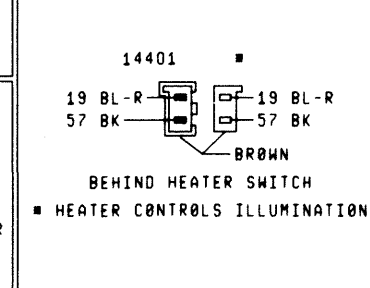
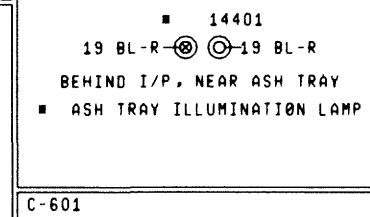
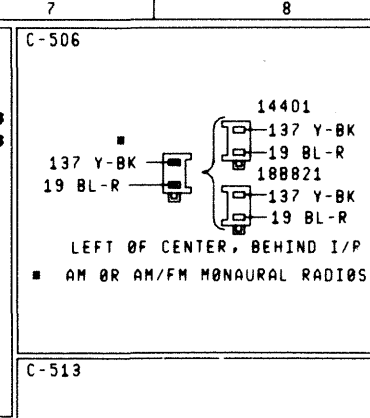
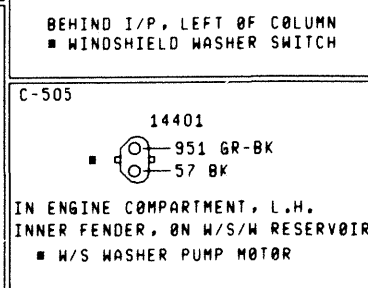
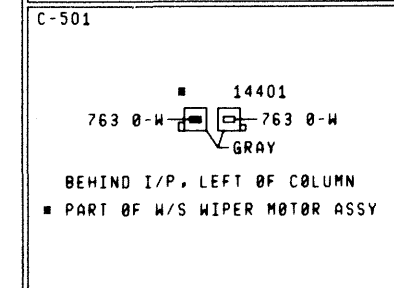
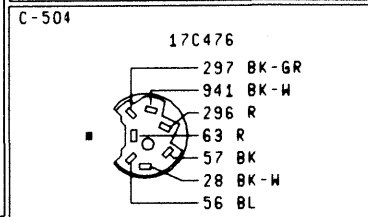
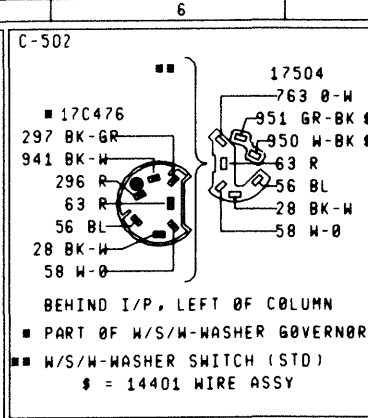
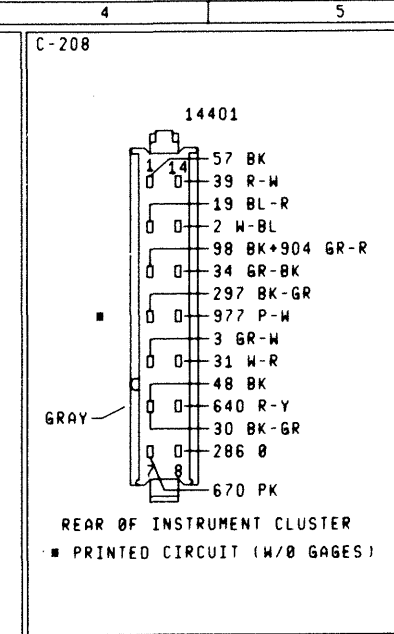
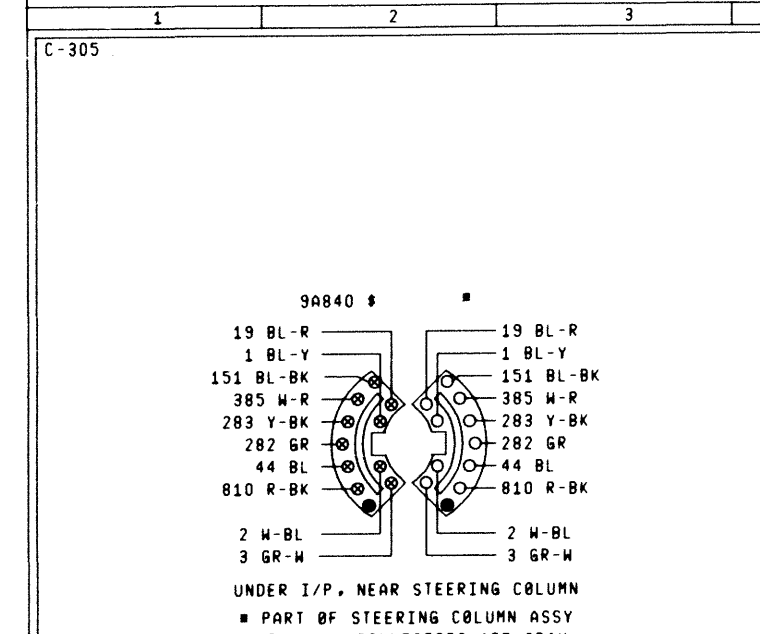
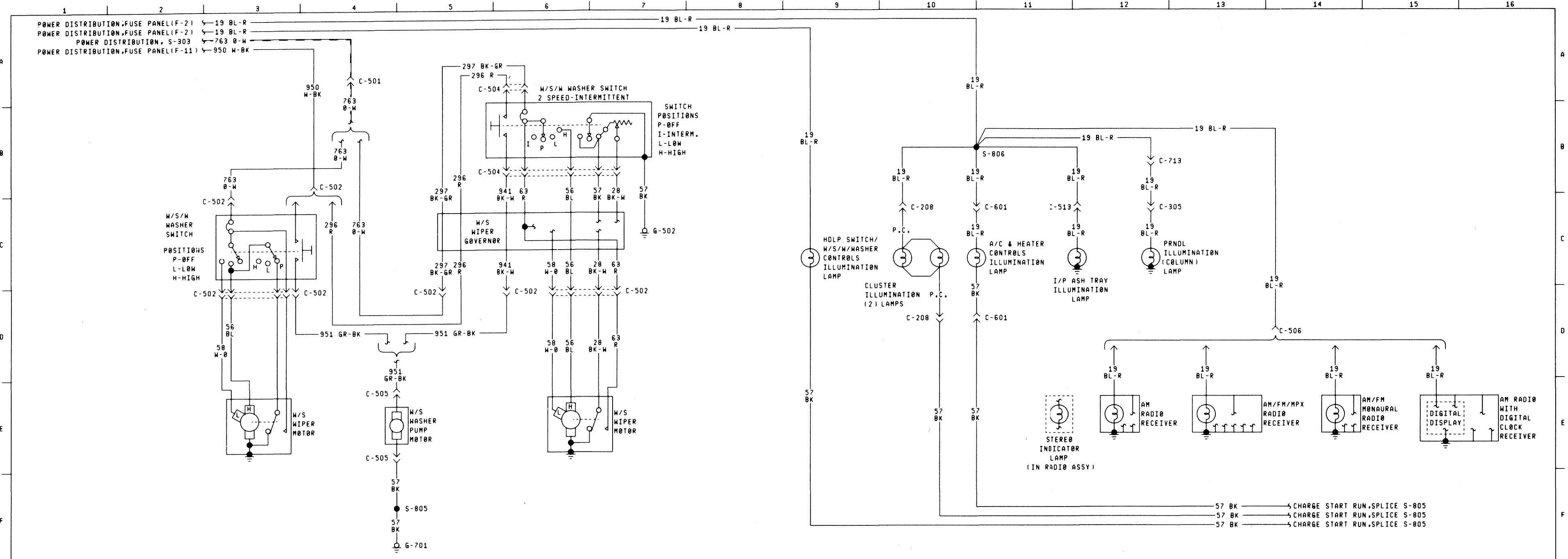

GROUND CODES	
6-502	ATTACHED TO I/P NEAR W/S WIPER SWITCH
6-701	IN 14401, ATTACHED TO "Y" BRACE

SPLICE CODES	
S-805	IN 14401, NEAR I/O TO W/S/W WASHER SWITCH
S-806	IN 14401, NEAR I/O TO PRINTED CIRCUIT

ELECTRICAL SYSTEMS 1978 BRONCO WINDSHIELD WIPER/WASHER ILLUMINATION LAMPS	
EFFECTIVE P.C.R. SUPERSEDES DATE 7-21-77	TR90 ELECT INST MAN PAGE E8T-900-9 SERVICE AND TRAINING MAN PAGE 9

100% SATISFACTION GUARANTEED

BUY IT NOW!

Click Here To Order

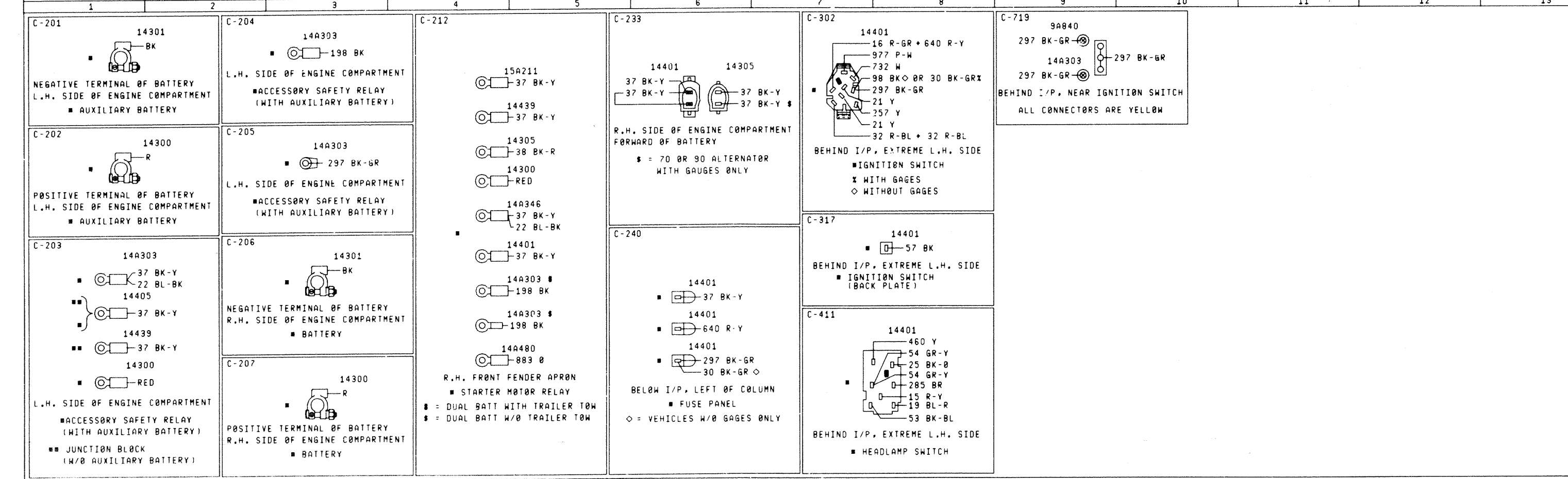
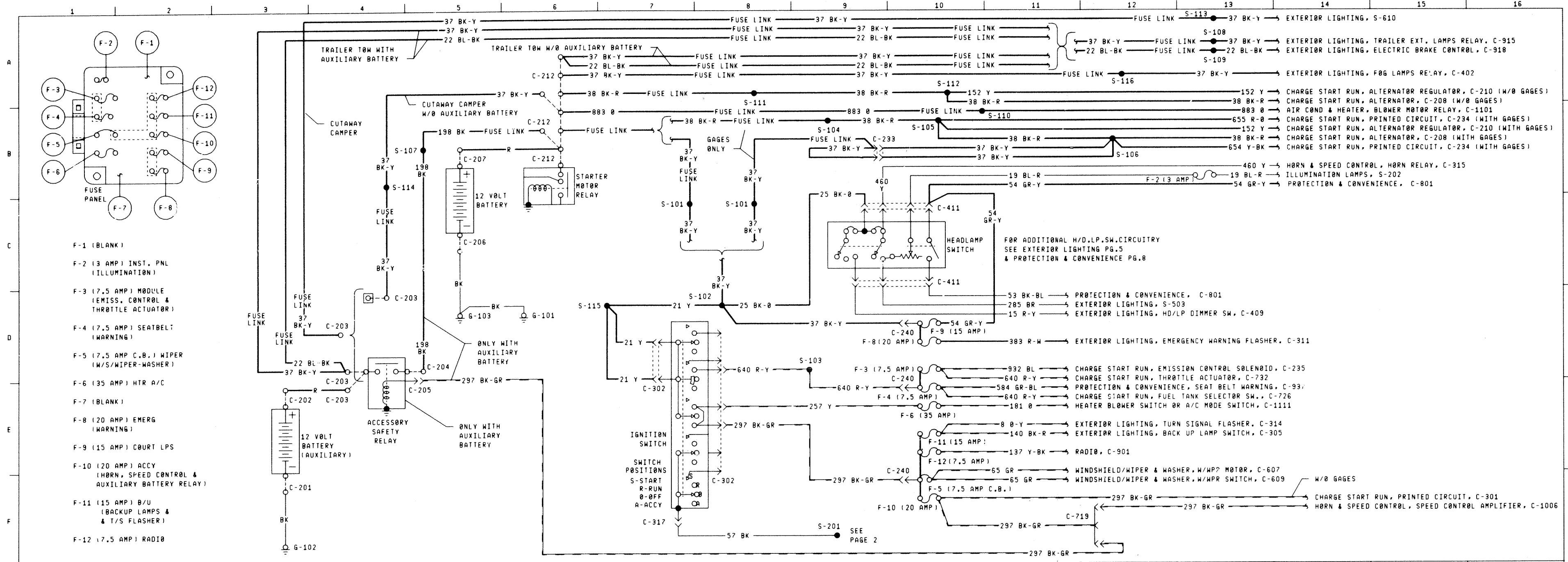

GROUND CODES	
G-101	EYELET ATTACHED TO R.H. SIDE ENGINE BLOCK
G-102	EYELET ATTACHED WITH ACCESSORY SAFETY RELAY L.H. SIDE OF ENGINE COMPARTMENT
G-103	EYELET ATTACHED TO R.H. SIDE OF ENGINE COMPARTMENT, BELOW BLOWER MOTOR

SPICE CODES	
S-101	IN 14401 NEAR STARTING MOTOR RELAY
S-102	IN 14401 NEAR T/O TO W/S WIPER MOTOR
S-103	TH 14401 NEAR TAKEOUT TO COLUMN WIRING
S-104	IN 14305, IN T/O TO STARTING MOTOR RELAY
S-105	IN 14305 NEAR T/O TO STARTING MOTOR RELAY
S-106	IN 14305, NEAR T/O'S TO 14401
S-107	IN 14A303 NEAR STARTING MOTOR RELAY
S-108	IN 14A303 OR 14A346 NEAR ACCY SAFETY RELAY
S-109	IN 14A303 OR 14A346 NEAR ACCY SAFETY RELAY
S-110	IN 14A480 NEAR STARTING MOTOR RELAY
S-111	IN 14305, IN T/O TO STARTING MOTOR RELAY
S-112	IN 14305 NEAR T/O TO STARTER MOTOR RELAY
S-113	IN 14405 NEAR ACCY SAFETY RELAY
S-114	IN 14439 NEAR ACCY SAFETY RELAY
S-115	IN 14401 NEAR T/O TO HEADLAMP SWITCH
S-116	IN 15A211 NEAR T/O TO STARTING MOTOR RELAY
S-201	IN 14401, NEAR T/O TO HEADLAMP AND IGNITION SWITCH ILLUMINATION

ELECTRICAL SYSTEMS 1978 ECONOLINE 7/16/77 POWER DISTRIBUTION	
EFFECTIVE P.C.R. SUPERSEDES DATE 7-22-77	TRPO ELECT INST MAN PAGE E8U-900-1 SERVICE AND TRAINING MAN PAGE 1



1978 Truck Shop Manual Volume 3 & 4 Body-Electrical

**Source Document
Extract Only
Volume 3 - Electrical**

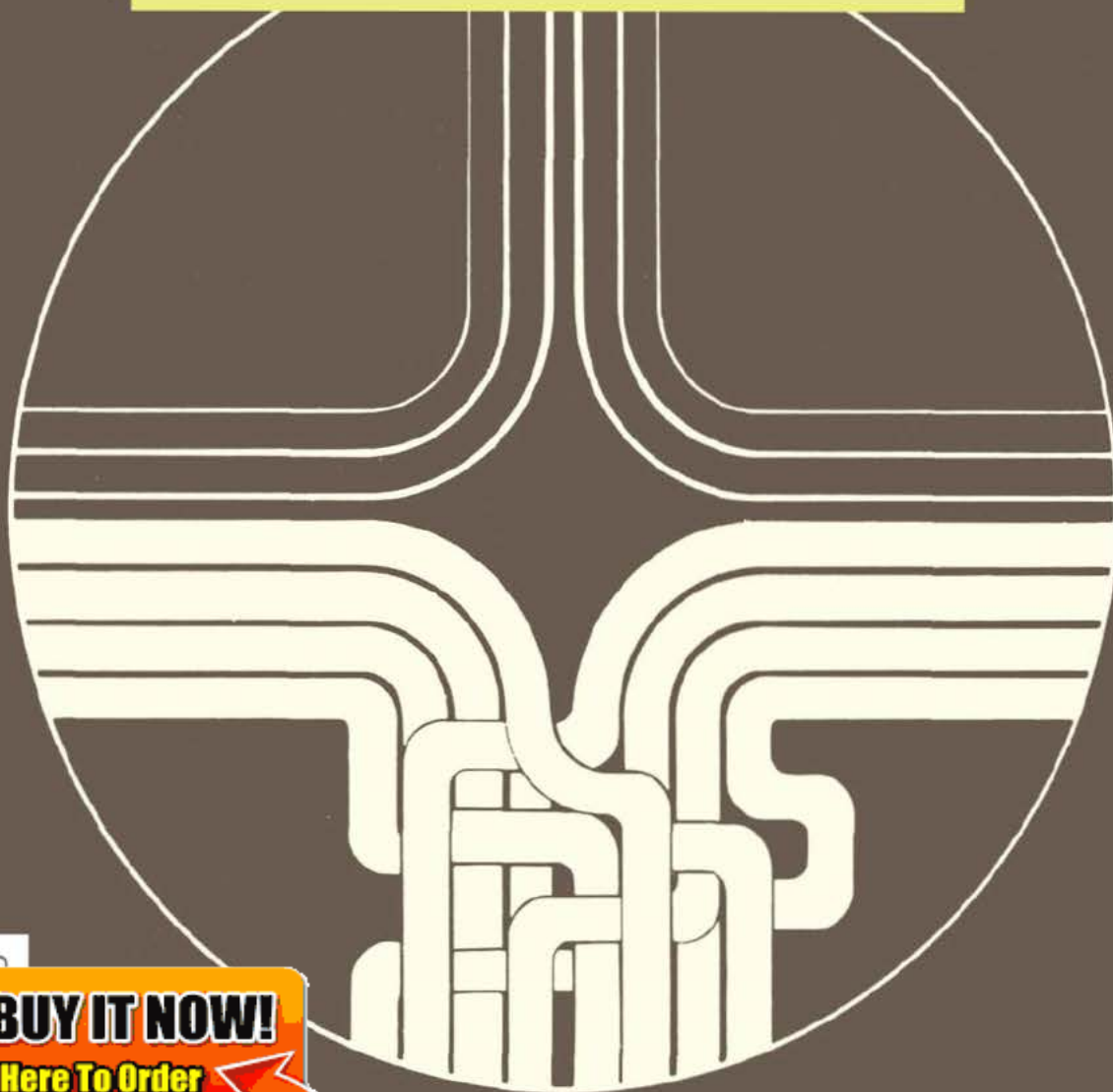

BUY IT NOW!

Click Here To Order



PayPal

Discover
Cards

AMERICAN
EXPRESS
NOVUS

MasterCard

VISA

GROUP AND PART INDEX

IDENTIFICATION CODES30-00-1	IDENTIFICATION CODES GROUP 30
ALTERNATOR — G.P.D. Rear Terminal31-10-1 — G.P.D. Side Terminal31-12-1 — Leece-Neville31-21-1 BATTERIES31-02-1 CHARGING SYSTEM GENERAL SERVICE31-01-1 REGULATOR — Alternator Electro-Mechanical31-40-1 — Alternator Transistorized31-42-1	CHARGING SYSTEM GROUP 31 (10000)
HEADLIGHT SYSTEM32-03-1 INTERIOR LIGHTS32-61-1 LIGHTING SYSTEM GENERAL SERVICE32-01-1 PARKING, REAR, AND MARKER LIGHTS32-21-1 TURN SIGNALS AND HAZARD FLASHERS32-41-1	LIGHTING SYSTEM GROUP 32 (13000)
CHARGE INDICATOR — Ammeter33-12-1 — Light33-10-1 — Voltmeter33-11-1 FUEL INDICATING SYSTEM33-20-1 IGNITION SWITCH33-71-1 INSTRUMENT CLUSTER AND PRINTED CIRCUIT33-51-1 INSTRUMENTS, CLUSTERS, AND CONTROLS GENERAL SERVICE33-01-1 OIL PRESSURE — Gauge33-32-1 — Light33-30-1 SPEEDOMETER33-02-1 TACHOMETER33-04-1 TEMPERATURE INDICATOR33-41-1	INSTRUMENTS, CLUSTERS, AND CONTROLS GROUP 33 (10000-19000)
CONNECTOR DISENGAGEMENT34-01-1 FUSES, CIRCUIT BREAKERS, AND FUSE LINKS34-31-1 INSTRUMENT PANEL-TO-DASH WIRING HARNESS34-02-1	MAIN WIRING HARNESS, CIRCUIT PROTECTION AND CONNECTORS GROUP 34 (14000)
ANTENNAS35-11-1 ASH RECEPTACLES AND CIGAR LIGHTER35-40-1 HORNS35-80-1 MIRRORS — Inside and Outside35-50-1 RADIO35-02-1 SPEAKERS35-31-1 WINDSHIELD WASHERS35-70-1 WINDSHIELD WIPERS — Air35-63-1 — Electric35-60-1	AUXILIARY EQUIPMENT GROUP 35 (17000 & 18000)
AIR CONDITIONING SYSTEM — General Service36-30-1 — C-Series Truck36-64-1 — E-100—E-35036-65-1 — E-100—E-350 Side-Mounted Auxiliary Htr. and/or Air Conditioning System36-70-1 — Light Truck and Bronco Heater-Air Conditioning System36-61-1 — L-Series Truck Heater-Air Conditioning System36-62-1 HEATED REAR WINDOW SYSTEM36-86-1 HEATING SYSTEM — General Service36-10-1 — Deluxe Hi-Lo Heater—Bronco and F-100—F-35036-25-1 — Deluxe Hi-Lo Heater—E-100—E-35036-24-136-23-136-65-136-70-136-20-136-61-136-62-136-02-1	VENTILATING, HEATING, AND AIR CONDITIONING GROUP 36 (18000 & 19000)
SPEED CONTROL SYSTEM37-01-1	SPEED CONTROL GROUP 37



BUY IT NOW!

Click Here To Order



To aid in locating specific items in this manual, the index at the front of each volume provides an alphabetical listing, with page number, for all Parts in the volume. The tab locator on the right side of this index will help you find the first page of each Group.

On the first page of each Group there is an index listing the Part title and Part number for each component covered within the Group. The first page of each Part contains an index to locate service operations covered in that Part. This Group-Part breakdown is also indicated in the page number located at the top of each page.

Example: 11-02-21 = (Group) 11 — (Part) 02 — (Page) 21

Metric conversion tables have been included at the back of each volume to aid in converting specifications in this manual to the metric equivalent.

The descriptions and specifications in this manual were in effect at the time this manual was approved for printing. Ford Motor Company reserves the right to discontinue models at any time, or change specifications or design without notice and without incurring obligation.

IMPORTANT SAFETY NOTICE

Appropriate service methods and proper repair procedures are essential for the safe, reliable operation of all motor vehicles as well as the personal safety of the individual doing the work. This Shop Manual provides general directions for accomplishing service and repair work with tested, effective techniques. Following them will help assure reliability.

There are numerous variations in procedures, techniques, tools, and parts for servicing vehicles, as well as in the skill of the individual doing the work. This Manual cannot possibly anticipate all such variations and provide advice or cautions as to each. Accordingly, anyone who departs from the instructions provided in this Manual must first establish that he compromises neither his personal safety nor the vehicle integrity by his choice of methods, tools or parts.



BUY IT NOW!

Click Here To Order



Ford Parts and Service Division
Training and Publications Department



IDENTIFICATION CODES

GROUP 30

Identification Codes

PART 30-00

APPLIES TO ALL MODELS

SUBJECT	PAGE	SUBJECT	PAGE
RATING PLATE	00-1	VEHICLE DATA (Cont'd)	
VEHICLE CERTIFICATION DECAL	00-1	Exterior Paint Color Codes	00-7
VEHICLE DATA	00-1	Max. GVW Codes	00-8
Assembly Plant Codes	00-6	Sequential Serial and Warranty	
Axle Codes (Front)	00-15	Number Codes	00-6
Axle Codes (Rear)	00-15	Transmission Codes	00-15
Body Codes	00-12	Truck Series Codes	00-4
D.S.O. Codes	00-15	Type/GVW Codes	00-8
Engine Codes	00-5	Wheelbase Codes	00-15
		VEHICLE IDENTIFICATION NUMBER	00-1

GENERAL INFORMATION

VEHICLE CERTIFICATION DECAL

The Vehicle Certification Decal (V.C. Decal) is attached to the rear face of the driver's door or door pillar (Fig. 1). The upper half of the decal contains the name of the manufacturer, the month and year of manufacture and the certification statement. The V.C. Decal also contains the Vehicle Identification Number.

The remaining information codes on the V.C. Decal are the same as the Truck Rating Plate Codes (Fig. 2). Vehicle codes shown on the Truck Rating Plate are explained in the following paragraphs.

RATING PLATE

Fig. 2 illustrates a typical Truck Rating Plate. On light and medium cowl and windshield vehicles, the Rating Plate is mounted on the right side of the cowl.

VEHICLE IDENTIFICATION NUMBER (VEHICLE SERIAL AND WARRANTY)

The identification number is the first line of numbers and letters appearing on the Rating Plate (Fig. 2). The first letter and two numbers indicate the truck series code. The letter following the truck series code designates the engine identification code. The letter following the engine identification code indicates the assembly plant at which the vehicle was built. The remaining numbers indicate the consecutive unit number (Serial and Warranty Number). The charts that follow list the various vehicle identification number codes.

VEHICLE DATA

The Vehicle Data appears on the Rating Plate on the two lines following the identification number. The first three digits under W.B. designate the wheelbase in inches. The one or two letters under COLOR identify the exterior paint color (two letters designate a two-tone). The letter and three digits under TYPE/G.V.W. designate the

truck model within a series and the gross vehicle weight rating. The letter and numerals under BODY designate the interior trim, seat and body type. The transmission installed in the vehicle is identified under TRANS by either a numeric or alphabetical code (if two symbols appear, the first identifies the auxiliary transmission, if so equipped, and the second symbol identifies the main transmission). A letter and a number or two numbers under AXLE identify the rear axle ratio (when required, a letter is also stamped behind the rear axle code to identify the front axle capacity). The maximum gross vehicle weight in pounds is stamped under MAX. G.V.W.

A two-digit number is stamped under D.S.O. to identify the district which ordered the vehicle. If the vehicle is built to special order (Domestic Special Order, Foreign Special Order, Limited Production Option, or other special order), the complete order number will also appear under D.S.O. The charts that follow Figure 2 list the various vehicle data codes.

100% SATISFACTION GUARANTEED

BUY IT NOW!

Click Here To Order

PayPal American Express Discover MasterCard VISA

COMPLETE VEHICLES

(UNITED STATES)

1 → MFD. BY FORD MOTOR CO. IN U.S.A.

2 → 08/77

3 → FRONT GAWR: 2870LB

4 → 1301 KG

5 → H78 — 15B

6 → 15 x 5.5K

7 → GYWR: 5750 LB/2608 KG

8 → REAR GAWR 3218LB

9 → 1459 KG

10 → H78 — 15B

11 → 15 x 5.5K

12 → AT 32 PSI COLD

THIS VEHICLE CONFORMS TO ALL APPLICABLE FEDERAL MOTOR VEHICLE SAFETY STANDARDS IN EFFECT ON THE DATE OF MANUFACTURE SHOWN ABOVE.

VEH IDENT NO. E04BHAE0000

TYPE TRUCK

F0187
T0571

COLOR	DSO	BODY	TRIM	SCH.	DATE	AXLE	TRANS	A/C
-------	-----	------	------	------	------	------	-------	-----

13

(CANADA)

MFD, BY FORD MOTOR CO. OF CANADA LTD.

GYWR:

FRONT GAWR: REAR GAWR:

WITH TIRES RIMS WITH TIRES RIMS

AT PSI COLD AT PSI COLD

THIS VEHICLE CONFORMS TO ALL APPLICABLE FEDERAL MOTOR VEHICLE SAFETY STANDARDS IN EFFECT ON THE DATE OF MANUFACTURE SHOWN ABOVE

VEH. IDENT. NO. CANADA BUILT UNITS

TYPE UTILITZE SAME TYPE DATA AS U.S.A.

COLOR	DSO	BODY	TRIM	SCH.	DATE	AXLE	TRANS	A/C
-------	-----	------	------	------	------	------	-------	-----

MADE IN CANADA



DECAL APPLIED TO ALL CANADIAN BUILT UNITS.

INCOMPLETE VEHICLES

THE INCOMPLETE VEHICLE LABEL IS ATTACHED TO A BOOKLET (INCOMPLETE VEHICLE MANUAL) AND SECURED TO A SUITABLE INTERIOR LOCATION FOR INFORMATION USE AT DESTINATION.

(UNITED STATES)

THIS INCOMPLETE VEHICLE MFD. BY FORD MOTOR COMPANY THE AMERICAN ROAD DEARBORN, MICHIGAN 48121 ON: 08/77

VEH. IDENT. NO. E37HHAED002

GVWR 1000 LB/4335 KG

FRONT GAWR	REAR GAWR	REAR REAR GAWR
4000 LB	6700 LB	LB
1814 KG	3039 KG	KG

FRONT	REAR
8.00 — 16.5E	8.00 — 18.5E
16.5 x 6.0	16.5 x 6.0
60	55

TIRES RIMS PSI COLD

MAY BE COMPLETED AS: TRUCK BUS (NOT SCHOOL BUS)

(EXPORT)

THIS INCOMPLETE VEHICLE MFD. BY FORD MOTOR COMPANY THE AMERICAN ROAD DEARBORN, MICHIGAN 48121 ON: 08/77

VEH. IDENT. NO.

GVWR

FRONT GAWR	REAR GAWR	REAR REAR GAWR

FRONT	REAR

TIRES RIMS PSI COLD

MAY BE COMPLETED AS: THIS VEHICLE MFD FOR EXPORT ONLY ON DATE SHOWN ABOVE

NOTE — The same information is on all safety certification decal although the location of the information on the decal may be different.

- ① Name of Manufacturer
- ② Date of Manufacture
- ③ Front Gross Axle Weight Ratings in Pounds (LB) and Kilograms (KG)

- ④ Rear Gross Axle Weight Rating in Pounds (LB) and Kilograms (KG)
- ⑤ Rear Tire Size
- ⑥ Rim Size
- ⑦ Rear Tire Cold PSI
- ⑧ Vehicle Identification Number (See Fig. 2 for details)
- ⑨ Vehicle Data (See Fig. 2 for details)



BUY IT NOW!

Click Here To Order



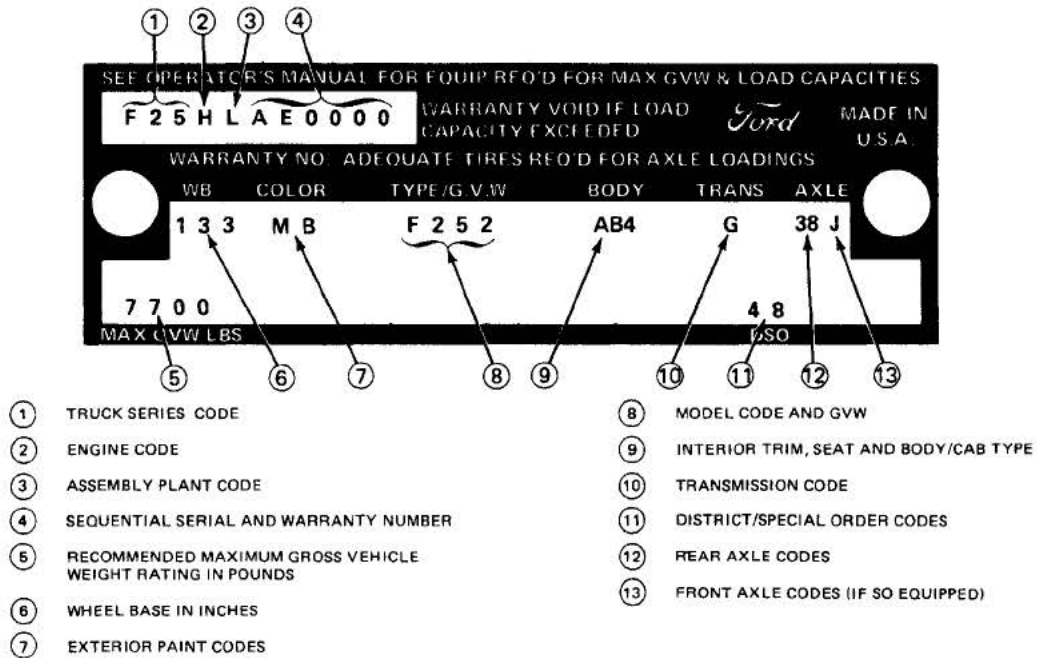

W1017-L

FIG. 2 Typical Truck Rating Plate

100% SATISFACTION GUARANTEED

BUY IT NOW!

Click Here To Order

PayPal

Discover Cards

Discover NOWUS

MasterCard

VISA

TRUCK SERIES CODES

OPERATOR'S MANUAL FOR EQUIP. R.D. FOR MAX. GVW & LOAD CAPACITIES

F 2 5 H L A E 0 0 0 WARRANTY VOID IF LOAD CAPACITY EXCEEDED *Ford* MADE IN U.S.A.

WARRANTY NOT ADEQUATE THIS R.D. FOR AXLE LOADINGS

1 3 3 M B F 2 5 2 AB4 G 38 J

7 7 0 0 4 8 DSO

MAX. GVW LBS

BRONCO

Code	Description
U15	U-150 (Wagon) 4x4

E-100 THRU E-350

Conventional Code	Super Code	Description
E-100 Series		
E01	—	E100 Club Wagon 5 Passenger
E02	—	E100 Club Wagon 8 Passenger
E04	—	E100 Cargo Van
E05	—	E100 Window Van
E06	—	E100 Display Van
E-150 Series		
E11	S11	E150 Club Wagon 5 Passenger
E12	S12	E150 Club Wagon 8 Passenger
E14	S14	E150 Cargo Van
E15	S15	E150 Window Van
E16	S16	E150 Display Van

E-250 Series

E20	S20	E250 Club Wagon 11 Passenger
E21	S21	E250 Club Wagon 5 Passenger
E22	S22	E250 Club Wagon 8 Passenger
E23	S23	E250 Club Wagon 12 Passenger
—	S29	E250 Club Wagon 15 Passenger
E24	S24	E250 Cargo Van
E25	S25	E250 Window Van
E26	S26	E250 Display Van

E-350 Series

E30	S30	E350 Club Wagon 11 Passenger
—	S32	E350 Club Wagon 8 Passenger
—	S33	E350 Club Wagon 12 Passenger
—	S39	E350 Club Wagon 15 Passenger
E34	S34	E350 Cargo Van
E35	S35	E350 Window Van
E36	S36	E350 Display Van

Econoline "Cutaway" Model

E27	—	E250 Cutaway
E37	—	E350 Cutaway

Parcel Delivery

E28	—	E250 Cutaway
E38	—	E350 Cutaway

F-SERIES CONVENTIONAL — GAS

Code	Pick-Up
------	---------

F-SERIES SUPER CAB — GAS

Chassis Cab Code	Pick-Up Code	Basic Series
X17	X10	F100
X16	X14	F150 4x4
X19	X15	F150
X27	X25	F250
X28	X26	F250 4x4
X37	X35	F350

F-600 — CONVENTIONAL — GAS

Code	Basic Series
F60	F600
F61	F600
F65	F600 4x4
F66	F600 4x4

B-600 — COWL BUS — GAS

Code	Basic Series
B60	B600
B61	B600

F-700 — 7000 — CONVENTIONAL

Code	Basic Series
F70	F700 (Gas)
F82	F800 (Gas)
K70	F7000 (Diesel)
K71	F7000 (Diesel)

B-700 — 7000 BUS CHASSIS COWL

Code	Basic Series
B70	B700 (Gas)
B71	B700 (Gas)
J70	B7000 (Diesel)

P-600 — GAS

Code	Basic Series
P60	P600

L-SERIES — CONVENTIONAL

Code	Basic Series
L-Series — Diesel	
A90	LT-900 (LTL 9000 DSO)
L-Series — Gas	
F80, F81	L800
F90, F91	L900

L-SERIES — CONVENTIONAL (Cont'd)

Code	Basic Series
L-Series — Diesel	
K80	L8000
K81	L8000
K90	L9000
LT-Series — Gas	
T80, T81	LT800
T90, T91	LT900
LT-Series — Diesel	
U80, U81	LT8000
U90, U91	LT9000
LTS-Series — Gas	
V80, V81	LTS800
V90, V91, V92	LTS900
LTS-Series — Diesel	
Y80, Y81	LTS8000
Y90, Y91, Y92	LTS9000

N-SERIES — SHORT CONVENTIONAL

Code	Basic Series
N-Series — Gas	
N60	N600
N61, N62	N600
N70, N71	N700
N75, N76	N750
N80, N81	N800
N90, N91	N900
N-Series — Diesel	
R70, R71	N7000
R80, R81	N8000
R90	N9000
NT-Series — Gas	
S80, S81	NT800
S90, S91	NT900
NT-Series — Diesel	
W80, W81	NT8000
W90, W91	NT9000

C-SERIES — LOW TILT CABS

Code	Basic Series
C-Series — Gas	
C60	C600
C61	C600
C70	C700
C75	C750
C80	C800
C90, C91	C900
C-Series — Diesel	
D70	C7000
D80	C8000
CT-Series — Gas	
L80	CT800
L90, L91	CT900
CT-Series — Diesel	
Q80	CT8000

100% SATISFACTION GUARANTEED

BUY IT NOW!

Click Here To Order

PayPal, American Express, Discover, MasterCard, VISA

ENGINE CODES

ENGINE CODES

GAS ENGINE CODES—BRONCO

Code	Engine CID	Litre	Cyl.
H	351-2V	5.8L	8
S	400-2V	6.6L	8

GAS ENGINE CODES—LT. TRUCK (F-100 THRU F-350)

Code	Engine CID	Litre	Cyl.
B	300-1V	4.9L	6
G	302-2V	5.0L	8
Z	(DSO)		
H	351-2V	5.8L	8
S	400-2V	6.6L	8
J	460-4V	7.5L	8

GAS ENGINE CODES—MEDIUM TRUCK (F AND B-600)

Code	Engine CID	Litre	Cyl.
B	300-1V H.D.	4.9L	6
D	330-2V X.D.	5.4L	8
E	361-4V X.D.	5.9L	8
O	330-2V LPG (DSO)	5.4L	8
W	361-4V LPG (DSO)	5.9L	8
M	361-2V LPG (DSO)	5.9L	8
X	391-4V LPG (DSO)	6.4L	8
J	300-2V LPG (DSO)	4.9L	6
Z	(DSO)		

GAS ENGINE CODES—EXPORT LOW COMP.

Code	Engine CID	Litre	Cyl.
2	300-1V	4.9L	6
4	330-2V X.D.	5.4L	8
5	361-2V X.D.	5.9L	8
8	351-2V	5.8L	8

GAS ENGINE CODES—E-100 THRU E-350 (ECONOLINE AND CLUB WAGON)

Code	Engine CID	Litre	Cyl.
B	300-1V	4.9L	6
H	351-2V	5.8L	8
A	460-4V	7.5L	8
C	300-1V (3x6 Fuel Economy)	4.9L	6

GAS ENGINE CODES—700-900 SERIES AND N600-C600 PARCEL

Code	Low Comp. Code	Engine CID	Litre	Cyl.
G	—	300-1V H.D.	4.9L	6
D	4	330-2V H.D.	5.4L	8
E	—	361-4V H.D.	5.9L	8
F	—	361-4V H.D.	5.9L	8
J	—	475-4V	7.8L	8
K	—	477-4V S.D.	7.8L	8
			8.8L	8

SEE OPERATOR'S MANUAL FOR EQUIP. REQ'D FOR MAX. GVW & LOAD CAPACITY.

F 2 5 H L A E 0 0 0 0 WARRANTY VOID IF LOAD CAPACITY EXCEEDED

WARRANTY NO. ADEQUATE TIRES REQ'D FOR ALL

WB	COLOR	TYPE / GVW	BODY	TRANS.	TIRES
1 3 3	M B	F 2 5 2	AB4	G	38 J

7 7 0 0 4 8

MAX GVW LBS DSO

DIESEL ENGINE CODES — CATERPILLAR

CODE	CID	MODEL	H.P.	RPM
B	636	3208	175HP	2800
D	636	3208	210HP	2800
Q	636	3208	200HP	2800
H	893	3406	280HP	2100
J	893	3406 HT	280HP	1900
M	893	3406	325HP	2100
C	Special Order Caterpillar DSO			

DIESEL ENGINE CODES — CUMMINS

CODE	CID	MODEL	H.P.	RPM
1	855	NH230	230HP	2100
9	855	NTC230	230HP	2100
X	855	NTC230	230HP	1900
F	855	NTC250	250HP	2100
5	855	NTC250	250HP	1900
K	855	NTC270PT	270HP	2100
V	855	NTC290	290HP	2100
U	855	NTC290	290HP	1900
8	855	NTC350	320HP	2100
3	855	NTC350	320HP	1900
L	855	NTC350	350HP	2100
P	855	NTC350	350HP	1900
G	903	V903	295HP	2600
S	Special Order Cummins DSO			

DIESEL ENGINE CODES — DETROIT

Code	CID	Model	H.P.	RPM
1	318	6V-53TT	210HP	2500
0	318	6V-53TT	225HP	2500
2	426	671N	228HP	2100
7	568	8V71N	263HP	2100
6	568	8V71N	280HP	2100
T	568	8V71N	304HP	2100
N	568	8V71T	308HP	2100
E	568	8V71T	335HP	2100
Y	568	8V71T	350HP	2100
4	568	8V71TT	305HP	1950
A	Special Order Detroit DSO			
Z	Special Order DSO			
R	Delete Engine (Glider) DSO			



BUY IT NOW!

Click Here To Order



ASSEMBLY PLANT AND SEQUENTIAL SERIAL AND WARRANTY NUMBER CODES

ASSEMBLY PLANT CODES

Code	Assembly Plant
B	Oakville
C	Ontario Truck
E	Mahwah
H	Lorain
K	Kansas City
L	Michigan Truck
N	Norfolk
R	San Jose
S	Allen Park
U	Louisville
V	Kentucky Truck

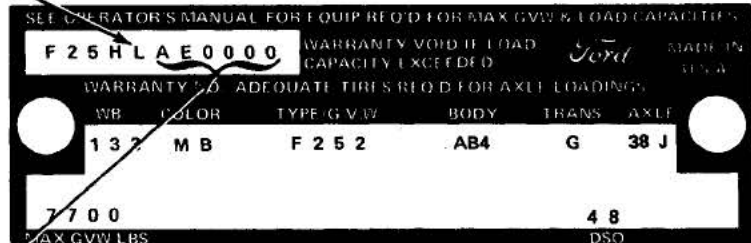

SEQUENTIAL SERIAL AND NUMBER WARRANTY NUMBER CODES (1978 MODEL YEAR)

Bronco, LT Truck (F-100 Thru F-350)

Code	Month and Year
AEO, 000 — AF9, 999	August, 1977*
AGO, 000 — AH9, 999	September, 1977
AJO, 000 — AK9, 999	October, 1977
BAO, 000 — BB9, 999	November, 1977
BCO, 000 — BD9, 999	December, 1977
BE0, 000 — BF9, 999	January, 1978
BGO, 000 — BH9, 999	February, 1978
BJO, 000 — BK9, 999	March, 1978
CA0, 000 — CB9, 999	April, 1978
CC0, 000 — CD9, 999	May, 1978
CE0, 000 — CF9, 999	June, 1978
CG0, 000 — CH9, 999	July, 1978
CJO, 000 — CK9, 999	August, 1978

E-100 Thru E-350 (Econoline and Club Wagon)

Code	Month and Year
AEO, 000 — AF9, 999	August, 1977*
AGO, 000 — AH9, 999	September, 1977
AJO, 000 — AK9, 999	October, 1977
BA0, 000 — BB9, 999	November, 1977
BC0, 000 — BD9, 999	December, 1977
BE0, 000 — BF9, 999	January, 1978
BGO, 000 — BH9, 999	February, 1978
BJO, 000 — BK9, 999	March, 1978
CA0, 000 — CB9, 999	April, 1978
CC0, 000 — CD9, 999	May, 1978
CE0, 000 — CF9, 999	June, 1978
CG0, 000 — CH9, 999	July, 1978
CJO, 000 — CK9, 999	August, 1978

F- and B-800 (Kentucky Truck Plant)

Code	Month and Year
AEO, 000 — AE4, 999	August, 1977*
AGO, 000 — AG4, 999	September, 1977
AJO, 000 — AJ4, 999	October, 1977
BA0, 000 — BA4, 999	November, 1977
BC0, 000 — BC4, 999	December, 1977
BE0, 000 — BE4, 999	January, 1978
BGO, 000 — BG4, 999	February, 1978
BJO, 000 — BJ4, 999	March, 1978
CA0, 000 — CA4, 999	April, 1978
CC0, 000 — CC4, 999	May, 1978
CE0, 000 — CE4, 999	June, 1978
CF0, 000 — CF4, 999	July, 1978
CG0, 000 — CG4, 999	August, 1978

700Thru 9000 Series and N600 — C600 Parcel

Code	Month and Year
AE5, 000 — AF9, 999	August, 1977*
AG5, 000 — AH9, 999	September, 1977
AJ5, 000 — AK9, 999	October, 1977
BA5, 000 — BB9, 999	November, 1977
BC5, 000 — BD9, 999	December, 1977
BE5, 000 — BF9, 999	January, 1978
BG5, 000 — BH9, 999	February, 1978
BJ5, 000 — BK9, 999	March, 1978
CA5, 000 — CB9, 999	April, 1978
CC5, 000 — CD9, 999	May, 1978
CE5, 000 — CF9, 999	June, 1978
CG5, 000 — CH9, 999	July, 1978
CJ5, 000 — CK9, 999	August, 1978

100% SATISFACTION GUARANTEED

BUY IT NOW!

Click Here To Order

*Job #1—1978 Model Year

EXTERIOR PAINT COLOR CODES

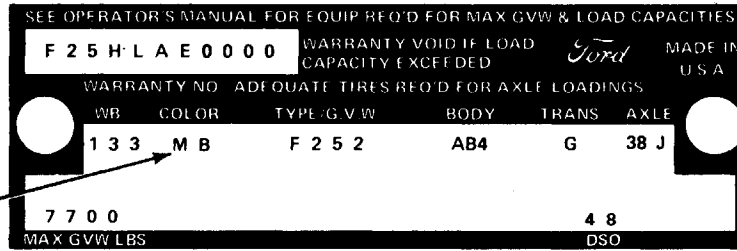

Color Code ^①	Color	Suffix #	Spec. #	Ref. #
1C (A)	Black	C1A	JASAXXA	1724-A
1G (J)	Silver Met.	90P	SPLCXXA	5299-A
1M (V)	Med. Silver Met.	B5P	EPKCXXA	5488-A
2E (T)	Candyapple Red	80D	JDMAXXA	2008-A
2J (N)	Maroon	65D	JDQAXXA	3059-A
2R (K)	Br. Red	78D	CDJAXXA	5440-A
2V (J)	Rangoon Red	79D	JDNAXXA	1515-A
3G (S)	Br. Dk. Blue Met.	H9B	SBQCXXA	5094-A
3T (I)	Br. Med. Blue	C8B	QBMAXXA	5004-A
3U (B)	Lt. Blue	87B	EBLAXXA	5467-A
46 (B)	Dk. Jade Met.	16K	AKQCXXA	5328-A
2A (F) ^①	Coral	77D	JDKAXXA	1730-A
5Q (F) ^②	Dk. Brown Met.	75T	YTQCXXA	5477-A
6P (U)	Cream	34V	AVFAXXA	5406-A
6S (G)	Chrome Yellow	07V	JVMAXXA	1526-A
64 (6)	Br. Yellow	09V	GVTAXXA	5574-A
6U (X)	Lt. Tan	52U	CULAXXA	5441-A
7A (R)	Lt. Jade	12R	CRJAXXA	5445-A
7D (L)	Holly Green	89R	JRQAXXA	1237-A
7U (W)	Br. Emerald	08M	EMNAXXA	5500-A
72 (L)	Midnight Jade	45R	GRSAXXA	5530-A
8F (Q)	Tangerine	13E	CEKAXXA	5459-A
8Q (I)	Med. Copper	41C	CCMAXXA	5475-A
82 (H)	Dk. Brown Met.	70T	ZTQCXXA	5282-A
83 (7)	Tan	43T	GTJAXXA	5524-A
9A (M)	White	26W	JWFAXXA	1619-A
9E (C)	Special White	32W	JWGAXXA	1525-A
99 (9)	Prime	—	XW Prime	— — —
Glamour Colors^③				
7N (Y)	Jade Met.	62R	ERVDXXA	5505-A
8U (P)	Dk. Nectarine Met.	08T	ETQDXXA	5506-A
RPO Unique Colors (Non Polish) "D"^④				
7N (Y)	Jade Met.	62R	ERVDXXA	5505-A
8T (E)	Nectarine Met.	37T	CTMDXXA	5507-A
3V (D)	Br. Blue Met.	89B	EBMDXXA	5480-A



BUY IT NOW!

Click Here To Order

① F-100 thru F-350 Only

300 series only

Trucks use the two digit paint identification code system (corporate code) but will only show the single code for the rating plate

() parenthesis in the code column.

CY1815-A



TYPE/GVW AND MAX. G.V.W. CODES

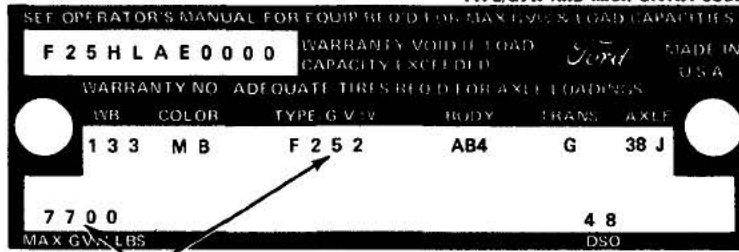

BRONCO		
Code	G.V.W.	
U150	6100	
U151	6400	
U152	6550	
U153	6010	
F-100 (4x2)		
Pickup Code	Chassis Cab Code	G.V.W.
F100	F170	4900
F101	F171	4800
F106	F176	5400
F107	F177	5600
F10N	F17N	5200
F-100 (4x2) Super Cab		
Pickup Code	Chassis Cab Code	G.V.W.
X108	X178	5700
X109	X179	5800
X10N	X17N	5200
F-150 (4x2)		
Pickup Code	Chassis Cab Code	G.V.W.
F150	F190	6050
F151	F191	6150
F150 (4x2) Super Cab		
Pickup Code	Chassis Cab Code	G.V.W.
X150	X190	6050
X152	X192	6200
X153	X193	6400
F-150 (4x4)		
Pickup Code	Chassis Cab Code	G.V.W.
F140	F160	6050
F141	F161	6300
F142	F162	6500
F-150 (4x4) SUPER CAB		
Pickup Code	Chassis Cab Code	G.V.W.
X143	X163	6400
F-250 (4x2)		
Pickup Code	Chassis Cab Code	G.V.W.
F250	F270	6200
F251	F271	6800
F252	F272	7700
F253	F273	7900
F-250 (4x2) SUPER CAB		
Pickup Code	Chassis Cab Code	G.V.W.
F254	F274	6200
F255	F275	6800
F256	F276	7700
F257	F277	7900

F-250 (4x4)		
Pickup Code	Chassis Cab Code	G.V.W.
F263	F283	6700
F264	F284	7300
F265	F285	8100
F266	F286	8400
F-250 (4x4) SUPER CAB		
Pickup Code	Chassis Cab Code	G.V.W.
X260	X280	7100
X261	X281	7600
X262	X282	8500
F-350 (4x2)		
Pickup Code	Chassis Cab Code	G.V.W.
F351	F370	6600
—	F371	6750
—	F372	8000
F353	F373	8200
—	F374	8300
—	F375	8500
—	F376	8900
—	F377	9500
—	F378	10,000
F354	—	8300
F356	—	8900
F359	—	9900
—	F37N	10,250
—	F37P	9100
F-350 (4x2) SUPER CAB		
Pickup Code	Chassis Cab Code	G.V.W.
X359	X379	9200
F-600 (4x2)		
Code	G.V.W.	
F600	16,000	
F602	19,200	
F603	14,000	
F604	16,000	
F605	17,400	
F606	17,400	
F611	20,200	
F612	21,000	
F613	22,000	
F614	22,000	
F615	23,000	
F616	24,000	
F618	17,900 U-Haul	
F-600 (4x4)		
Code	G.V.W.	
F650	17,200	
F660	21,700	
F661	24,000	
B600 BUS (4x2)		
Code	G.V.W.	
B600	17,400	
B601	19,200	
B602	19,200	
B610	19,700	
B611	20,200	
B613	21,000	
B615	22,000	
B617	24,500	
B618	22,160	
B619	23,160	

E-100 CLUB, CUSTOM, AND CHATEAU WAGONS	
Conv. Code	G.V.W.
E010	5500
E012	5900
E013	5700
E020	5900
E021	6000

E-150 CLUB, CUSTOM, AND CHATEAU WAGONS			
Conv. Code	Super Code	Conv. G.V.W.	Super G.V.W.
—	S110	—	6025
—	S111	—	6200
E112	S112	6200	6400
E113	S113	6400	6600
E114	S114	6500	6800
E120	S120	6300	6200
—	S121	—	6400
—	S122	—	6600
E123	S123	6500	6800
E124	—	6700	—

E-250 CLUB, CUSTOM, AND CHATEAU WAGONS			
Conv. Code	Super Code	Conv. G.V.W.	Super G.V.W.
—	S200	—	7600
—	S201	—	7800
—	S202	—	8000
E203	S203	7600	8300
E204	S204	7900	8500
E205	—	8100	—
E206	—	8500	—
E207	—	8900	—
—	S210	—	7000
—	S211	—	7200
—	S212	—	7400
—	S213	—	7700
E214	S214	6800	8000
E215	—	7100	—
E216	—	7800	—
—	S220	—	6900
—	S221	—	7200
E222	S222	8200	7400
—	S223	—	7700
E224	S224	6900	8000
E225	S225	7100	8300
E226	—	7300	—
E227	—	7500	—
E228	—	7700	—
—	S230	—	7600
—	S231	—	7800
—	S232	—	8000
E233	S233	7600	8300
E234	S234	7900	8500
E235	—	8100	—
E236	—	8500	—
E237	—	8900	—
—	S290	—	7000
—	S291	—	7900
—	S292	—	8100
—	S293	—	8200
—	S294	—	8300
—	S295	—	8400

E-350 CLUB, CUSTOM, AND CHATEAU WAGONS	
Code (Super)	G.V.W.
S300	8000
S301	8300
S302	8800
S303	9000
S304	9300
S320	7900
S321	8100
S322	8400
S323	8700
S324	9100
S330	8000
S331	8300
S332	8800
S333	9000
S334	9300
S390	8600
S391	8800
S392	9100
S393	9400

100% SATISFACTION GUARANTEED

BUY IT NOW!

Click Here To Order

TYPE/GVW AND MAX. GVW CODES — CONTINUED

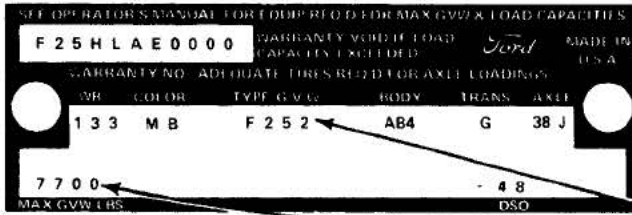

E-100 ECONOLINE CARGO, WINDOW, AND DISPLAY VANS

Conv. Cargo Code	Conv. Window Code	Conv. Display Code	G.V.W.
E040	E050	E060	5150
E041	E051	E061	5750

E-150 ECONOLINE CARGO, WINDOW, AND DISPLAY VANS

Conv. Cargo Code	Super Cargo Code	Conv. Window Code	Super Window Code	Conv. Display Code	Super Display Code	G.V.W. (Conv.)	G.V.W. (Super)
—	S140	—	S150	—	S160	—	6050
E141	—	E151	—	E161	—	6100	—
E142	—	E152	—	E162	—	6300	—

E-250 ECONOLINE CARGO, WINDOW, AND DISPLAY VANS

Conv. Cargo Code	Super Cargo Code	Conv. Window Code	Super Window Code	Conv. Display Code	Super Display Code	G.V.W. (Conv.)	G.V.W. (Super)
—	S240	—	S250	—	S260	—	6500
E241	S241	E251	S251	E261	S261	7550	7100
—	S242	—	S252	—	S262	—	7900
E243	—	E253	—	E263	—	6750	—
E244	—	E254	—	E264	—	8250	—

E-250 CUTAWAY VAN

Code	G.V.W.
E270	8400

E-250 CUTAWAY PARCEL DELIVERY VAN

Code	G.V.W.
E280	7700

E-350 ECONOLINE CARGO, WINDOW, AND DISPLAY VANS

Conv. Cargo Code	Super Cargo Code	Conv. Window Code	Super Window Code	Conv. Display Code	Super Display Code	G.V.W. (Conv.)	G.V.W. (Super)
—	S340	—	S350	—	S360	—	8100
—	S341	—	S351	—	S361	—	9100
—	S342	—	S352	—	S362	—	9400
E343	—	E353	—	E363	—	8550	—
E344	—	E354	—	E364	—	9500	—
E345	—	E355	—	E365	—	9800	—

E-350 CUTAWAY VAN

Code	G.V.W.
E370	8700 Single Rear
E371	9650 Single Rear
E372	8750 Dual Rear
	11,000 Dual Rear
	10,000 Dual Rear
	10,100 Dual Rear

E-350 CUTAWAY PARCEL DELIVERY VAN

Code	G.V.W.
E380	8750 Dual Rear
E382	10,000 Dual Rear
E383	10,500 Dual Rear
E384	9800 Dual Rear



BUY IT NOW!

Click Here To Order



TYPE/GVW AND MAX. G.V.W. CODES — CONTINUED

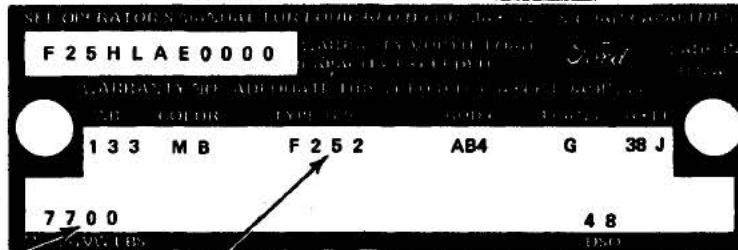

B-700 BUS CHASSIS COWL — GAS	
Code	G.V.W.
B702	23,160
B705	25,080
B706	24,500
B707	25,250
B708	27,080
B709	26,500
B710	27,250

B-7000 BUS CHASSIS COWL — DIESEL	
Code	G.V.W.
J707	26,500
J708	27,250
J709	27,080

F-700 — GAS	
Code	G.V.W.
F701	21,000
F703	23,000
F704	24,000
F706	25,500
F707	25,000
F708	27,000
F709	27,500

F-800 — GAS	
Code	G.V.W.
F820	23,000
F821	25,000
F822	25,500
F823	27,000
F824	27,500
F825	29,000
F826	31,000
F827	32,000

F-7000 — DIESEL	
Code	G.V.W.
K703	23,000
K705	24,000
K706	25,500
K707	27,500
K708	25,000
K709	27,000
K710	21,000

L-800 — GAS (Cont'd)	
Code	G.V.W.
F806	31,000
F807	32,000
F808	34,000
F809	35,000
F811	31,800
F812	27,000

L-900 — GAS	
Code	G.V.W.
F900	25,500
F902	27,500
F905	31,000
F906	32,000
F908	34,000
F909	35,000
F912	23,000
F913	31,800

L-8000 — GAS	
Code	G.V.W.
K802	25,500
K803	27,000
K805	31,000
K806	32,000
K807	34,000
K808	35,000
K812	23,100
K813	31,800

L-9000 — GAS	
Code	G.V.W.
K902	32,000
K904	35,000
K907	28,000
K908	31,000

LT-800 — GAS	
Code	G.V.W.
T804	43,000
T806	46,000
T811	41,000
T812	44,800

LT-900 — GAS	
Code	G.V.W.
T900	39,000
T902	41,000
T904	43,000
T906	46,000
T907	50,000
T908	50,000
T909	54,000

LT-900 — GAS (Cont'd)	
Code	G.V.W.
T911	60,000
T914	44,800
T915	48,000
T916	52,000
T917	58,000

LT-8000 — DIESEL	
Code	G.V.W.
U800	39,000
U805	46,000
U806	50,000
U807	50,000
U808	54,000
U809	60,000
U810	55,000
U811	56,000
U812	62,000
U815	41,000
U816	44,800
U817	61,000

LT-9000 — DIESEL	
Code	G.V.W.
U900	43,000
U903	46,000
U904	50,000
U905	50,000
U906	54,000
U907	58,000
U908	60,000
U909	60,000
U910	62,000
U911	52,000
U912	62,000
U913	72,000
U914	44,800
U915	61,000
U916	48,000
U917	58,000
U918	74,000
U919	76,000

LTS-800 — GAS	
Code	G.V.W.
V804	46,000
V809	41,000
V810	44,000

LTS-900 — GAS	
Code	G.V.W.
V900	39,000
V904	46,000

LTS-900 — GAS (Cont'd)	
Code	G.V.W.
V905	50,000
V906	50,000
V907	52,000
V908	54,000
V909	56,000
V911	58,000
V912	60,000
V913	62,000
V914	64,000
V915	61,000
V918	41,000
V920	48,000

LT-9000 — GAS	
Code	G.V.W.
A900	44,800
A901	46,000
A902	48,000
A903	50,000
A904	50,000
A905	52,000
A906	54,000
A907	58,000
A908	60,000

LTS-9000 — GAS	
Code	G.V.W.
Y900	44,800
Y901	58,000
Y902	60,000
Y903	50,000
Y904	50,000
Y905	52,000
Y906	54,000
Y907	56,000
Y908	61,000
Y909	58,000
Y910	60,000
Y911	62,000
Y912	62,000
Y913	72,000
Y914	74,000
Y915	76,000
Y916	78,000
Y917	77,100
Y918	70,000
Y919	48,000
Y920	79,100
Y921	81,100

100% SATISFACTION GUARANTEED

BUY IT NOW!

Click Here To Order

TYPE/GYW AND MAX. G.V.W. CODES — (CONTINUED)

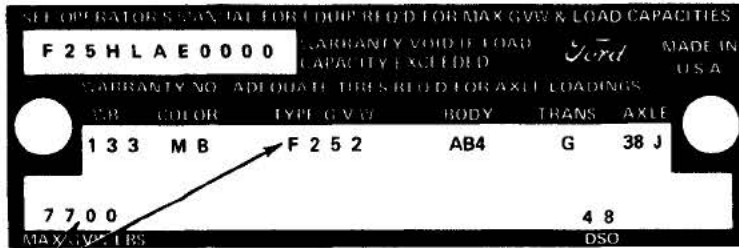

LTS-8000 — DIESEL

Code	G.V.W.
Y800	39,000
Y804	46,000
Y805	50,000
Y806	50,000
Y807	52,000
Y808	54,000
Y812	60,000
Y814	64,000
Y815	55,000
Y816	56,000
Y817	61,000
Y818	41,000
Y819	62,000

N-600 — GAS

N601	16,500
N602	19,500
N603	21,500
N612	23,000
N615	24,000
N620	22,000

N-700 — GAS

N702	23,000
N703	25,500
N705	27,000
N706	27,500
N707	25,000
N710	21,000
N712	24,000

N-800 — GAS

N800	23,000
N801	25,000
N803	25,500
N804	27,500
N805	29,000
N806	31,000
N807	27,000
N808	34,000
N813	31,800
N814	32,000
N815	35,000

N-900 — GAS

Code	G.V.W.
N900	25,500
N902	27,500
N905	31,000
N906	32,000
N908	34,000
N909	35,000
N911	23,100
N912	31,800

N-7000 — GAS

R702	23,000
R704	25,500
R705	25,000
R707	27,500
R708	27,000
R710	21,000
R712	24,000

N-8000 — GAS

R802	25,500
R803	27,500
R805	31,000
R806	32,000
R807	34,000
R808	35,000
R810	23,100
R811	31,800

N-9000 — GAS

R902	32,000
R904	35,000
R906	28,000
R907	31,800

NT-800 — GAS

S804	43,000
S806	46,000
S811	41,000
S812	44,800

NT-900 — GAS

S900	39,000
S902	41,000
S904	43,000
S906	46,000
S907	50,000
S909	54,000
S914	44,800
S915	48,000
S916	52,000

NT-8000 — DIESEL

Code	G.V.W.
W800	39,000
W803	56,000
W804	62,000
W805	46,000
W806	50,000
W807	50,000
W808	54,000
W812	41,000
W814	44,800
W815	55,000
W816	60,000
W817	61,000

NT-9000 — DIESEL

W903	46,000
W904	50,000
W906	54,000
W907	43,000
W910	58,000
W911	44,800
W912	48,000
W913	52,000
W914	60,000
W915	62,000
W916	72,000
W917	74,000
W918	76,000

P-600 — GAS

P600	15,000
P603	12,000
P602	17,000
P605	17,000

C-600 — GAS

C602	17,000
C612	23,000
C613	24,000
C617	21,200

C-700 — GAS

C700	24,000
C701	25,000
C702	25,500
C703	27,000
C704	27,500
C705	21,000

C-800 — GAS

Code	G.V.W.
C802	27,500
C803	31,000
C804	34,000
C807	25,100

C-900 — GAS

C904	25,100
C906	31,000
C907	32,000
C910	34,000
C912	37,000
C914	25,100
C915	39,000

C-7000 — GAS

D701	21,000
D702	25,500
D703	24,000
D704	25,000
D705	27,500
D706	27,000
D708	23,000

C-8000 — GAS

D802	27,500
D806	25,100
D807	32,000
D808	35,000

CT-800 — GAS

L801	42,860
L803	44,000
L805	45,000
L807	46,000
L808	48,000
L809	50,000

CT-900 — GAS

L901	42,860
L902	44,000
L903	45,000
L914	46,000
L915	48,000
L916	50,000
L917	52,000
L918	54,000
L919	50,000

CT-9000 — DIESEL

Q801	42,860
Q803	45,000
Q804	44,000
Q805	41,000
Q807	46,000
Q808	48,000
Q809	50,000



BUY IT NOW!

Click Here To Order



BODY CODES (BRONCO, LIGHT TRUCK, MEDIUM TRUCK, SCHOOL BUS, 100 THRU 600 SERIES)

SEE OPERATOR'S MANUAL FOR EQUIP. RECD FOR MAX. GVW & LOAD CAPACITIES

F 2 5 H L A E 0 0 0 0 WARRANTY VOID IF LOAD CAPACITY EXCEEDED *Ford* MADE IN U.S.A.

WARRANTY NO. ADEQUATE TIRES REQ'D FOR AXLE LOADINGS

WB	COLOR	TYPE	GVW	BODY	TRANS.	AXLE
1	3	M	B	F 2 5 2	AB4	G 38 J

7 7 0 0 MAX GVW LBS 4 8 DSO

BODY

On Cowl/Windshield Bus & Parcel Units the first two spaces remain blank.

TRIM CODE (Material and Seat Type)

Bronco Custom			Ranger		
Code	Trim Type		Code	Bench Trim Type	
A	Vinyl	Bucket	B	Vinyl	
B	Vinyl Bench		E	Knit & Vinyl	
Bronco Ranger			H	Leather Grain Vinyl	
C	Vinyl	Bucket	K	B/Cloth & Vinyl (LGO Decor)	
D	B/Cloth and Vinyl	Bucket	P	Vinyl (Youth Package)	
E	Vinyl	Bench	Q	B/Cloth and Vinyl	
F	B/Cloth and Vinyl	Bench	U	Knit and Vinyl	
Light Truck Custom Bench			Z	Knit and Vinyl	
A	Vinyl		Ranger XLT Bench		
D	Knit & Vinyl		C	B/Cloth and Vinyl	
G	Leather Grain Vinyl		F	Knit and Vinyl	
P	Vinyl (Youth Package)		J	Leather Grain Vinyl	
F600 Cabs			K	B/Cloth and Vinyl (LGO Decor)	
A	Vinyl	Standard Trim Standard Cab	L	Vinyl	
D	Knit and Vinyl	Optional Trim Standard Cab	P	Vinyl (Youth Package)	
E	Knit and Vinyl	Optional Custom Cab	V	Knit and Vinyl	
G	Leather Vinyl	Optional Heavy Duty Standard Cab	L/B Bench		
H	Leather Vinyl	Optional Heavy Duty Custom Cab	L/B Bench		
K	Leather Vinyl	Optional Bostrom Seat Standard Cab	L/B Bench		
L	Leather Vinyl	Optional Bostrom Seat Custom Cab	L/B Bench		

TRIM COLOR CODES

With HD Vinyl Opt. (Black Seat Only)

Code	Color	Code	Color
Q	Blue	A	Black
N	Red	B	Blue
5	Jade	D	Red
9	Saddle	R	Jade
		Z	Saddle

BODY TYPE CODE

F100-350

6-Man Crew Super Cab

Regular

F/B 600

Code	Specifications
7	Cowl
8	Chassis Cab Steel Regular
6	Chassis Crew Cab
6	Chassis Cab Steel, Fire Truck Regular

Code	Specifications
3	Flareside Pick-Up
4	Styleside Pick-Up
5	Platform Stake
8	Chassis Cab
9	Platform

100% SATISFACTION GUARANTEED

BUY IT NOW!

Click Here To Order

PayPal American Express Discover MasterCard VISA

BODY CODES (E-100 THRU E-350)

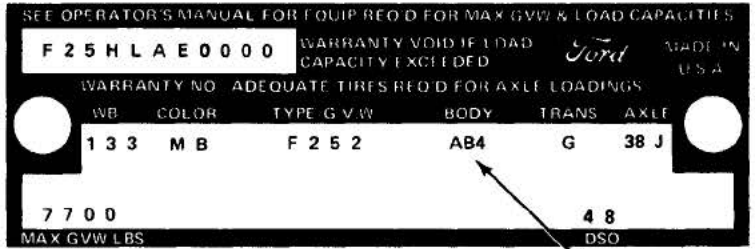

BODY

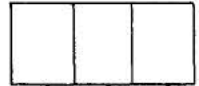

TRIM CODE (Material and Seat Type)

Cutaway, Wagons and Vans with Pass. Seat Codes	Cutaway Vans Driver Only Code	Cutaway Vans with Jump Seat Code	Trim Scheme	
A	V	Z	A Vinyl	Bucket
B	W	—	B Vinyl	Bucket
C	X	—	C B/Cloth & Vinyl	Bucket
D	Y	—	D Vinyl	Bucket
F	—	—	F Vinyl	Captain Chair
G	—	—	G Vinyl	Captain Chair
H	—	—	H B/Cloth & Vinyl	Captain Chair
J	—	—	J Vinyl	Captain Chair
K	—	—	K Vilon Knit & Vinyl	Captain Chair
L	—	—	L Vilon Knit & Vinyl	Captain Chair
M	—	—	M Vilon Knit & Vinyl	Captain Chair

TRIM COLOR CODES

Code	Color
A	Black
B	Blue
R	Jade
U	Tan

BLANK (Not used on Econoline)

BODY CODES (700 THRU 9000 SERIES, N600 — C000 PARCEL)

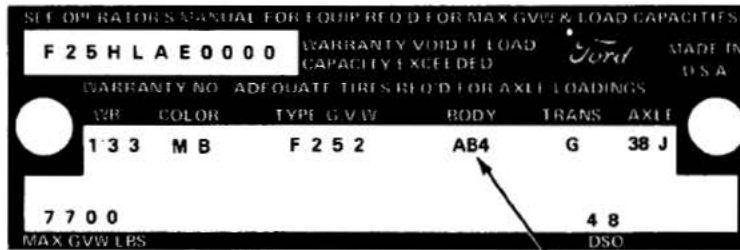

CAB TRIM CODE

Custom Trim Code	Standard Trim Code	Color
A	1	Gray
B	2	Blue
C	3	Saddle
D	4	Black
E	5	Red
F	6	Jade
H	8	Tobacco

On cowl/bus units the first two spaces remain blank

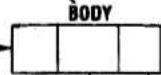

SEAT TYPE CODE

HD Black Vinyl Seat Code	W/Comp. Pass. Seat Code	Single Driver Seat Code	Bench Seat Code	Seat Type
A	—	—	1	Bench Seat
B	—	—	2	Bench Custom Seat
—	C	3	—	L-S (Unison Action)
—	D	4	—	L-S #675
—	E	5	—	Bostrom Westcoaster
—	F	6	—	Bostrom T-Bar
—	G	—	—	National Cush-n-Aire Lo/Bk
—	H	8	—	Bostrom Levelaire
—	I	9	—	National Cush-n-Aire Hi/Bk

BODY TYPE CODE

Sleeper W/Foam Mattress Code	Less Mattress Code	Body Type
		Parcel
		Chassis Cab/w Butterfly Hood Cowl
		Chassis Cab, Steel
		Fire Truck/Emergency CC Steel
		Chassis Cab w/Butterfly Hood Fire Truck

100% SATISFACTION GUARANTEED

BUY IT NOW!

Click Here To Order

WHEELBASE, TRANSMISSION, AXLE, AND D.S.O. CODES

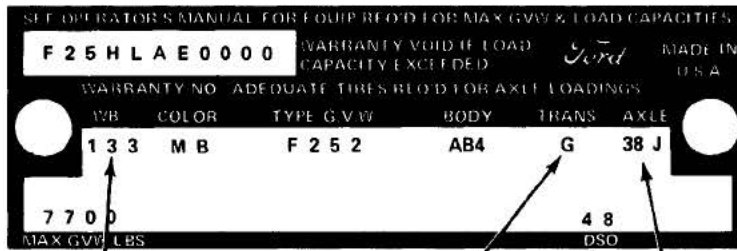

WHEEL BASE

Wheel Base of the vehicle in inches.

TRANSMISSION CODES

Refer to Volume 1 (Group 10-00), Volume 2 (Group 20-00), or Volume 5 (Group 50-00) for a complete list of transmission codes.

AXLE CODES

Refer to Volume 1 (Group 10-00), Volume 2 (Group 20-00), or Volume 5 (Group 50-00) for a complete list of front and rear axle codes.

DISTRICT SALES OFFICE (DSO) CODE

DSO — FSO — PTO (DOMESTIC, FOREIGN AND SPECIAL ORDER)

The D. S. O. space will show a two digit code number of the district which ordered the unit (see chart below). This code will appear on all units — domestic or export. If unit is built on a D.S.O., E.S.O., P.T.O., (special orders) the complete order number is under the D.S.O. space **after** the district code.

DISTRICT CODES

11 Boston	41 Chicago	71 Los Angeles	Ford of Canada	
12 Buffalo	42 Cleveland	72 San Jose		
13 New York	43 Milwaukee	73 Salt Lake City		
14 Pittsburgh	45 Lansing	74 Seattle		
15 Newark	46 Indianapolis	75 Phoenix		
16 Philadelphia	47 Cincinnati	76 Denver		
17 Washington	48 Detroit			
21 Atlanta	52 Dallas	83 Government	Mercury Regions	
22 Charlotte	53 Kansas City	84 Home Office Reserve	Ford Regions	
23 Memphis	54 Omaha	85 American Red Cross	A1 Central	B1 Central
24 Jacksonville	55 St. Louis	89 Transportation Services	A2 Eastern	B2 Eastern
25 Richmond	56 Davenport	87 Body Company	A3 Atlantic	B3 Atlantic
26 New Orleans	57 Houston		A4 Midwestern	B4 Midwestern
28 Louisville	58 Twin Cities	90's Export	A6 Western	B6 Western
			A7 Pacific	B7 Pacific
			12 Export	12 Export

Note: Export Alphabetical 1

100% SATISFACTION GUARANTEED

BUY IT NOW!

Click Here To Order

CHARGING SYSTEM

**GROUP
31
(10000)**

PART TITLE	PART NO.	PART TITLE	PART NO.
Alternator Electro-Mechanical Regulator	31-40	E.E.D. Rear Terminal Alternator	31-10
Alternator Transistorized Regulator	31-41	G.P.D. Side Terminal Alternator	31-12
Batteries	31-02	Leece-Neville Alternators	31-21
Charging System General Service	31-01		

Charging System General Service

**PART
31-01**

APPLIES TO ALL MODELS

SUBJECT	PAGE	SUBJECT	PAGE
DESCRIPTION AND OPERATION	01-1	TESTING	01-4
Fuse Link	01-1	Alternator Indicator Light (Alt.)	01-5
DIAGNOSIS	01-2	Ammeter Test	01-5
Battery Check	01-2	Battery Drain Test	01-5
Charging System Check	01-2	Bench Tests	01-6
Diagnosis Guides	01-3	Charging System Fuse Link	01-8
Isolating the Problem	01-2	General Charging System Tests	01-5
Preliminary Information	01-2	On Vehicle Tests	01-4

DESCRIPTION AND OPERATION

The alternator charging system is a negative ground system, and consists of an alternator, regulator, charge indicator, storage battery, fuse link and associated wiring. Refer to the Wiring Diagram Manual for schematics and locations of wiring harnesses.

engine compartment wiring harness. It is several wire gages smaller than the circuit that it protects and is the color of the circuit being supplied by the fuse link. Service fuse links are green or black depending on usage. All fuse links have a flag moulded on the wire or on the terminal insulator. Color identification of the flag or connector is Red—18 gage wire, Orange—16 gage wire, or Green—14 gage wire.

The fuse link is designed to burn out, thus protecting the alternator and wiring

when heavy reverse current flows, such as when a booster battery is connected incorrectly, or a short to ground occurs in the wiring harness.

A burned out link may have bare wire ends protruding from the insulation, or it may only have expanded or bubbled insulation. If it is hard to determine if the link is burned out, perform a continuity test.

Refer to Part 34-31 for testing procedures for fuse links used in the charging system.



BUY IT NOW!

Click Here To Order



DIAGNOSIS

Certain tests outlined in the Parts within this Group are illustrated in the schematic and in pictorial form. The schematic illustrates the internal connections of the Rotunda or equivalent equipment so these connections can be duplicated when this equipment is not available. The various circuits involved in the tests can be selected by means of switches without the necessity of changing connections when the illustrated equipment is used. This reduces the time required to test units and circuits on the vehicle.

PRELIMINARY INFORMATION

Before performing charging or starting system tests on the vehicle, note the complaint such as: slow cranking, battery dead or using an excessive amount of water, top of battery wet, ammeter shows charge at all times and/or no charge, alternator warning lamp does not come on and/or never goes out. This information will aid in isolating the part of the system causing the symptom.

Next, visually inspect as follows:

1. Check the fuse link located between the starter solenoid and the alternator. Replace the fuse link if burned.
2. Check battery posts and battery cable terminals for clean and tight connections. Remove the battery cables (if corroded), clean and install them securely.

3. Check for clean and tight wiring connections at the alternator, regulator and engine.
4. Check the alternator belt tension and tighten to specification (if necessary), as shown in Part 31-10.

ISOLATING THE PROBLEM

Battery, starting system, and light systems problems can be caused by poor charging system performance. It is also possible to suspect the charging system because of an overload in another area of the electrical system.

To avoid guesswork, it is necessary to isolate the battery, the charging system, and the electrical circuits to correctly identify the area where the difficulty lies. The best method to do this is to check the battery first before any electrical system diagnosis. The battery must be in proper state of charge. The battery must be operating properly before the other areas of the electrical system can perform normally.

BATTERY CHECK

The battery should be checked to see if it has the capacity and ability to accept and hold a charge. If the battery is good, then the charging system should be checked to see that it performs its function of keeping the battery charged.

The battery capacity, specific gravity and cell comparison test will determine

the ability of a battery to accept and hold a charge. If the battery cannot meet the specifications it should be replaced and the new battery fully charged before further diagnosis of other areas of the electrical system.

If the battery is found to meet the required specifications, it should be fully charged before proceeding with the diagnosis of other electrical system components.

CHARGING SYSTEM CHECK

The General Charging System Test should be performed before testing any of the individual charging system components. It's "road-map" type of layout should reduce confusion in determining "what to do next" and speed up diagnosis. The component tests will determine the type of component repairs to be made.

The test instruments used in the General Charging System Test are a voltmeter (0-20 or 0-30 volt scale) and an ohmmeter. Special care should be given when using the ohmmeter near "hot" circuits. The component to be checked should be disconnected from the circuit or the battery terminals should be disconnected.

Continue through the Diagnosis Guides until a repair has been made. Then, again test the system to see if the repair has corrected the system problem.

100% SATISFACTION GUARANTEED

BUY IT NOW!

Click Here To Order

PayPal Discover American Express MasterCard VISA

DIAGNOSIS GUIDES

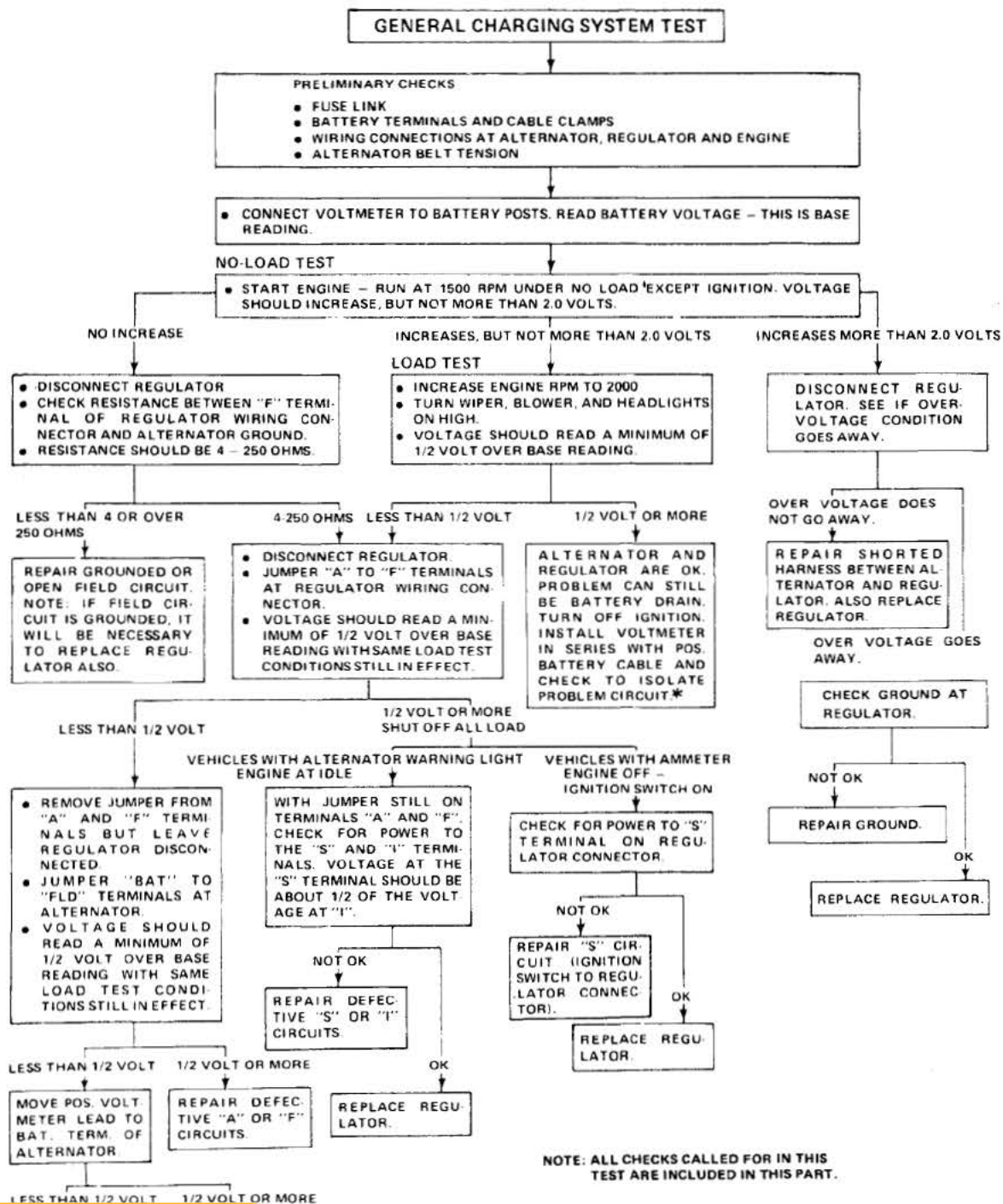

*IF NO DRAIN, CHECK BATTERY CAPACITY AND/OR PERFORM CELL COMPARISON TESTS



BUY IT NOW!

Click Here To Order



COMPLAINT	POSSIBLE CAUSE	CORRECTION
<ul style="list-style-type: none"> Battery does not stay charged — engine starts OK 	<ul style="list-style-type: none"> Worn or damaged battery Loose or worn alternator belt Worn or damaged wiring or cables Alternator or regulator Other vehicle electrical systems 	<ul style="list-style-type: none"> Test battery, replace if necessary Adjust or replace belt Clean, repair as required Perform general charging systems test. Repair or replace as required. Check other systems for current draw. Repair as required
<ul style="list-style-type: none"> Battery uses excessive water — lights burn out frequently 	<ul style="list-style-type: none"> Alternator regulator Worn or damaged wiring Worn or damaged battery 	<ul style="list-style-type: none"> Test, replace if necessary Tighten all ground connections. Repair as required Test battery, replace if necessary
<ul style="list-style-type: none"> Alternator noisy 	<ul style="list-style-type: none"> Loose or worn alternator belt Bent pulley flanges Alternator 	<ul style="list-style-type: none"> Adjust or replace belt Replace pulley Perform alternator tests. Repair or replace as required
<ul style="list-style-type: none"> Charge indicator light does not light when the ignition switch is turned on 	<ul style="list-style-type: none"> Loose or improper wiring connections Bulb burnt out Worn or damaged regulator or wiring 	<ul style="list-style-type: none"> Repair as required Replace bulb Disconnect regulator plug connector. Connect jumper wire from "I" terminal of connector to ground. Indicator should light. Connect jumper wire from "I" to "F". Indicator light should light. Check regulator to alternator wiring for continuity. Repair or replace as required
<ul style="list-style-type: none"> Charge indicator light stays on — engine running 	<ul style="list-style-type: none"> Loose or worn alternator belt Alternator regulator Alternator 	<ul style="list-style-type: none"> Adjust or replace belt By-pass regulator. If light goes out, replace regulator Perform general charging systems test. Repair or replace as required
<ul style="list-style-type: none"> Charge light stays on — key off 	<ul style="list-style-type: none"> Worn or damaged wiring Alternator or regulator 	<ul style="list-style-type: none"> Check and repair as required Disconnect connect plug from regulator. Check for voltage at "S" terminal of plug. If no volts and light goes out, replace regulator. If volt reading, repair or replace alternator
<ul style="list-style-type: none"> Charge indicator gauge shows steady charge 	<ul style="list-style-type: none"> Worn or damaged battery Poor regulator ground Loose wiring connections Alternator or regulator 	<ul style="list-style-type: none"> Check battery. Replace if necessary Assure good ground Tighten all wiring connections Perform general charging systems test. Repair or replace as required
<ul style="list-style-type: none"> Charge indicator light flickers while vehicle is being driven 	<ul style="list-style-type: none"> Loose or worn alternator belt Loose or improper wiring connections Alternator or regulator 	<ul style="list-style-type: none"> Adjust or replace belt Assure good proper connections Perform general charging systems test. Repair or replace as required
<ul style="list-style-type: none"> Charge indicator gauge shows discharge (if constant high reading, see "Battery Uses Excessive Water") 	<ul style="list-style-type: none"> Loose or worn alternator belt Worn or damaged wiring Alternator or regulator Charge indicator gauge wiring and connections Worn or damaged gauge Other vehicle electrical systems malfunction 	<ul style="list-style-type: none"> Adjust or replace belt Check battery to alternator wiring for ground or open. Repair if necessary Perform general charging systems test. Repair or replace as required Repair as required Replace gauge Check and repair as required

CJ1910-B1

TESTING

A voltmeter (0 to 20 volt scale), ohmmeter, jumper wire and a test light (12 volt) are the only tools required to perform an accurate check of the complete charging system. The meters should be calibrated once a year and the calibration stamped on the meter

an obvious fault makes the replacement of a unit necessary, find out why the unit failed. Refer to the Diagnosis Guide in this Part. When a trouble is diagnosed correctly, unnecessary repairs are prevented, the time the vehicle is out of service will be decreased, and the repairs that are made will be permanent.

ON VEHICLE TESTS

Before performing charging system tests on the vehicle, note the complaint such as: slow cranking, battery dead or using an excessive amount of water, top of battery wet, ammeter shows charge at

all times or no charge, alternator warning lamp does not come on or never goes out. This information will aid in isolating the part of the system causing the symptom.

Visual Inspection

1. Check the fuse link if so equipped located between the starter relay and the alternator. If burned, determine cause, repair system and replace fuse link.
2. The battery must be in proper state of charge (at least 1.200 specific gravity). Check the battery posts and battery cable terminals for clean and tight connections. Remove the

100% SATISFACTION GUARANTEED

BUY IT NOW!

Click Here To Order

FOURTEEN DAYS OF GUARANTEE

PayPal | American Express | Discover | MasterCard | VISA

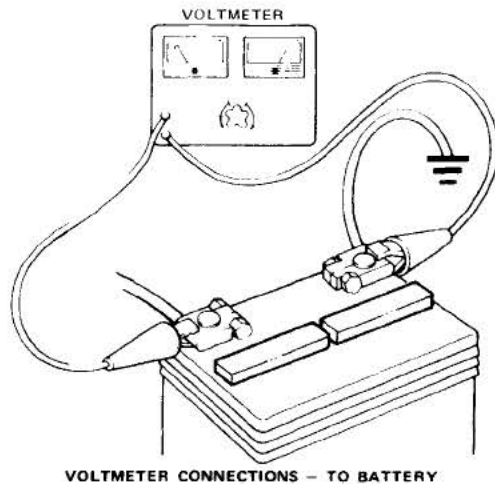

FIG. 1 Voltmeter—To—Battery Connections

3. battery cables (if corroded), clean and install them securely.
3. Check for clean and tight wiring connections at the alternator, regulator and engine.
4. Check the alternator belt tension and tighten to specification (if necessary). Refer to Part 31-10.

BATTERY DRAIN TEST

1. Connect a 12-volt test light in-series with the positive terminal of the battery. Test with all switches OFF. Do not be misled by clock-winding current. Touch cable clamp to terminal to wind clock.
2. If light glows, pull fuses, one at a time, and check each circuit for short. Repair wiring harnesses or components as required.

ALTERNATOR INDICATOR LIGHT (ALT) TEST

Normal Charge Indicator

With Ignition switch off, lamp is off.

With Ignition switch on (engine not running), charge indicator (ALT) lamp is on.

With Ignition switch on (engine running), charge indicator (ALT) lamp is off.

1. If the charge indicator lamp does not come on with the ignition key in the ON position and the engine not running, check for a short circuit or I terminal of the regulator wiring plug to the negative battery post cable

3. The charge indicator lamp should go on with the ignition key turned to the ON position.
4. If the charge indicator bulb does not go on, check the bulb for continuity and replace (if burned out).
5. If the bulb is not burned out, an open circuit exists between the ignition switch and the regulator.

Electro Mechanical and Transistorized Regulators

A good indication of a problem in the I wiring circuit (ignition switch to regulator I terminal) will show when the charge indicator light goes out when engine rpm is high. This may be caused by an open circuit in the 15 ohm resistor wire (connected in parallel with the indicator light) generally at the terminal point (either end of the resistor wire).

AMMETER TEST

Normal Charge Indication

With ignition switch off and no electrical load . . . Ammeter should show 0 or center scale.

With ignition switch ON and the engine running (fully charged battery), needle deflects towards charge and returns toward center scale in time.

With ignition switch off and headlamps on . . . Ammeter should show discharge. If the ammeter does not register a discharge, check for loose connections at the ammeter prior to replacing the gauge.

GENERAL CHARGING SYSTEM TESTS

When performing charging system tests with a voltmeter, turn OFF all lights and electrical components. Place the transmission in neutral and apply the

Base Voltage Test

1. Connect the negative lead of the voltmeter to the negative battery cable clamp.
2. Connect the positive lead of the voltmeter to the positive battery cable clamp (Fig. 1). Record the battery voltage reading shown on the voltmeter scale, (this is called the base voltage).

No Load Test

3. Connect a tachometer to the engine.
4. Start the engine and increase speed to approximately 1500 rpm. With no other electrical load (foot off brake pedal and doors closed), the voltmeter pointer should move upward (increase), but not more than 2 volts above the base voltage (first recorded battery voltage reading). The reading should be taken when the voltmeter pointer stops rising. It may take a few minutes to reach this point. If the pointer continues to rise, perform the OVER VOLTAGE TESTS described below.
5. With the engine running, turn the heater or air conditioner blower motor ON (high speed) and headlights on high beam.

Load Test

6. Increase the engine speed to approximately 2000 rpm. The voltmeter should indicate a minimum of 0.5 volt above the base voltage. If not, perform the UNDER VOLTAGE TEST described below.

If the above tests indicate proper voltage readings, the charging system is operating normally. Proceed to the tests below if one or more of the readings is different than shown above and use a test light and check for battery drain.

Over Voltage Tests

1. If the voltmeter reading indicates more than 2.0 volts above the base voltage, connect a jumper wire between the regulator base and the alternator frame. Repeat the NO LOAD test. This will check the ground connections between the regulator and alternator and/or regulator to engine. If an over voltage condition appears, clean and tighten connections securely.
2. If over voltage condition still exists, disconnect the regulator wiring plug from the regulator and repeat the NO LOAD test.
3. If over voltage condition disappears (voltmeter reads battery voltage), replace voltage regulator.
4. If over voltage still exists with the regulator wiring plug disconnected, repair the short in the wiring harness between the alternator and regulator.



BUY IT NOW!

Click Here To Order



Replace the regulator and connect the regulator wiring plug to the regulator.

Under Voltage Tests

1. To determine if the jumping procedure is safe, the field circuit should be checked with the regulator wiring plug disconnected and an ohmmeter connected from the F terminal of the regulator wiring plug to the battery ground. The ohmmeter should indicate more than three ohms (Fig. 2).
2. If the load voltage did not increase 1/2 volt above the base voltage, connect a jumper across the A and F terminals of the plug and repeat the LOAD TEST (Fig. 3).

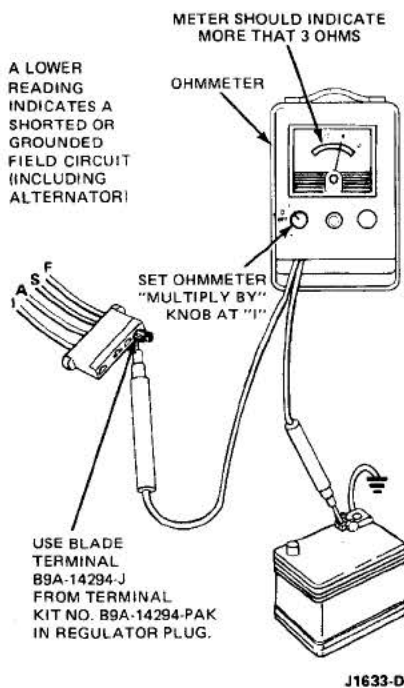
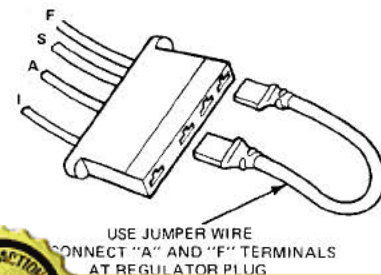

FIG. 2 Field Circuit Test



terminals on the alternator (Fig. 4) and repeat the LOAD TEST. If the voltmeter now indicates more than 1/2 volt above the base voltage, repair the wiring harness from the alternator to the regulator.

4. If the voltmeter still indicates under voltage, stop the engine and move the positive voltmeter lead to the alternator BAT terminal.
5. If the voltmeter now indicates the base voltage reading, repair the alternator. If the voltmeter indicates zero volts, repair the BAT wire (circuit 38).

Regulator I and S Circuit Tests S—Circuit With Ammeter

1. Connect the positive lead of the voltmeter to the S terminal of the regulator wiring plug. Then, turn the ignition switch to the ON position. Do not start the engine.
2. The voltmeter should indicate battery voltage.
3. If there is no voltage reading, repair the S wire lead from the ignition switch to the regulator wiring plug.
4. Connect the positive voltmeter lead to the positive battery cable terminal, connect regulator wiring plug to regulator and repeat the LOAD TEST.

S and I Circuit—With Indicator Light

1. Disconnect the regulator wiring plug and install a jumper wire between the A and F terminals (Fig. 3).
2. With the engine idling, connect the positive lead of the voltmeter to the S terminal and then to the I terminal of the regulator wiring plug. The voltage of the S circuit should read approximately 1/2 of the I circuit.
3. If no voltage is present, repair the wiring circuit. Reconnect the positive voltmeter lead to the positive battery cable terminal.
4. If the above circuit tests are satisfactory, install a new regulator.
5. Then, remove the jumper wire from the regulator wiring plug and connect the wiring plug to the regulator. Repeat the LOAD TEST.

Diode Test—On Vehicle

1. Disconnect the electric choke.
2. Disconnect voltage regulator wiring plug.
3. Connect a jumper between A and F terminal of voltage regulator wiring plug (Fig. 3).
4. Connect voltmeter to battery cable clamps.
5. Start engine—let engine run at idle.
6. Read and record the system voltage.

7. Move positive voltmeter lead to S-terminal of the alternator
8. Note the voltmeter reading.
9. Run the engine as described under NO LOAD TEST.

Test Results

1. If the voltmeter reads 1/2 of the system voltage, the diodes are OK.
2. If voltmeter reads approximately 1.5 volts, alternator has shorted negative diode, or a grounded stator winding.
3. If voltmeter reads approximately 1.5 volts less than battery voltage, alternator has shorted positive diode.
4. If voltmeter reads about 1.0 to 1.5 volts less than 1/2 battery voltage, alternator has an open positive diode.
5. If voltmeter reads about 1.0 to 1.5 volts more than 1/2 battery voltage, alternator has an open negative diode.
6. Connect the electric choke into the circuit after the test is completed.

BENCH TESTS

Rectifier Short or Grounded and Stator Grounded Test

These tests are performed with an ARE 27-42 ohmmeter or equivalent. Set the Multiply By knob at 10, and calibrate the ohmmeter as directed inside the instrument cover.

1. Contact one ohmmeter probe to the alternator BAT terminal (Fig. 5) and the other probe to the STA terminal (rear blade terminal). Then, reverse the ohmmeter probes and repeat the test. A reading of about 60 ohms should be obtained in one direction and no needle movement with the probes reversed. A reading in both directions indicates a bad positive diode, a grounded positive diode plate or a grounded BAT terminal.
2. Perform the same test using the STA and GND (ground) terminals of the alternator. A reading in both directions indicates either a bad negative diode, a grounded stator winding, a grounded stator terminal, a grounded positive diode plate, or a grounded BAT terminal.
3. Infinite readings (no needle movement) in all four probe positions in the preceding tests indicates an open STA terminal lead connection inside the alternator.

Field Open or Short Circuit Test

This test is performed with an ARE 27-42 ohmmeter or equivalent. Set the ohmmeter Multiply By knob at 1 and calibrate the ohmmeter as directed inside the instrument cover.

1. Contact the alternator field terminal with one probe and the ground terminal with the other probe (Fig. 6). Then, spin the alternator pulley. The

100% SATISFACTION GUARANTEED

BUY IT NOW!

Click Here To Order

PayPal | American Express | Discover | MasterCard | VISA

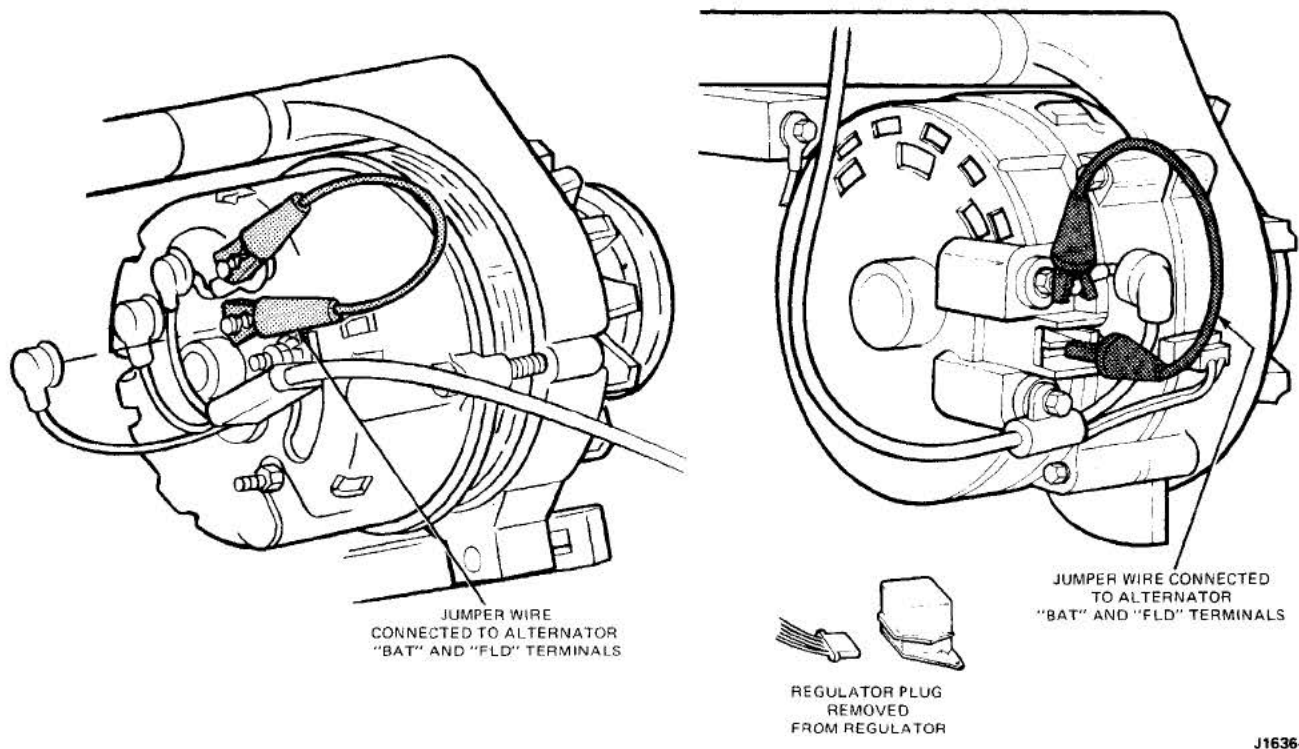

FIG. 4 Jumper Wire Connections

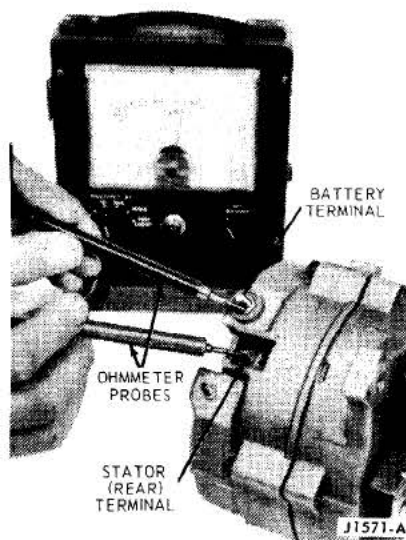

FIG. 5 Rectifier Short or Grounded and Stator Grounded Test

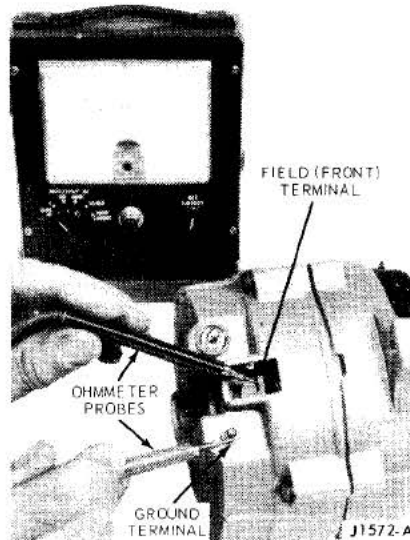

FIG. 6 Field Open or Short Circuit Test

1. To test one set of diodes, contact one probe to the diode plate as shown in Fig. 7 and contact each of the three stator lead terminals with the other probe. Reverse the probes and repeat the test. All diodes should show a low reading of about 60 ohms in one direction, and an infinite reading (no needle movement) with the probes reversed.
2. Repeat the preceding tests for the other set of diodes except that the other diode plate is used. The diode test for the Leece-Neville alternator is accomplished by placing one probe on the heat sink and contacting each of the three stator lead terminals with the other probe as shown in Fig. 8. The readings should be as indicated in the previous paragraph.
3. If the meter readings are not as specified, replace the rectifier assembly.

Stator Coil Open or Grounded Test

These tests are made to determine if the stator coil is operating properly. Disassemble the stator from the alternator as outlined under Disassembly in the appropriate alternator Part in Group 31.

Set the ARE 27-42 ohmmeter or equivalent Multiply By knob at 1, and calibrate the meter as directed inside the cover.

assembly, a grounded field terminal or a bad rotor.

Diode Test

Remove the rectifier assembly from the alternator as outlined in the appropriate Part in Group 31. Set the ohmmeter Multiply By Knob at 10 and calibrate the meter as directed inside the cover.

3. An ohmmeter reading less than 2.4 ohms indicates a grounded brush

100% SATISFACTORY GUARANTEED

BUY IT NOW!

Click Here To Order

PayPal

MasterCard

VISA

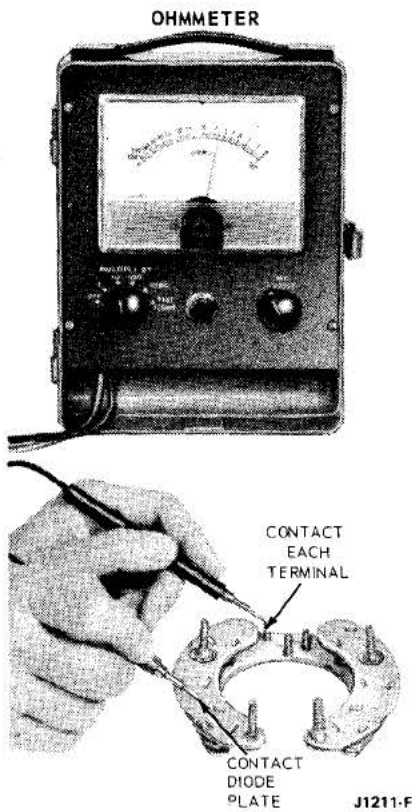

FIG. 7 Diode Test—Rear Terminal Alternator

1. Connect the ohmmeter probes between each pair of stator leads (3 different ways). The ohmmeter must show equal readings for each pair of stator leads. Replace the stator if the readings are not the same.
2. Set the ohmmeter Multiply By knob at 1000. Connect the ohmmeter probes to one of the stator leads and to the stator laminated core. Be sure that the probe makes a good electrical connection with the stator core. The meter should show an infinite reading (no meter movement).
3. If the meter does not indicate an infinite reading (needle moves), the

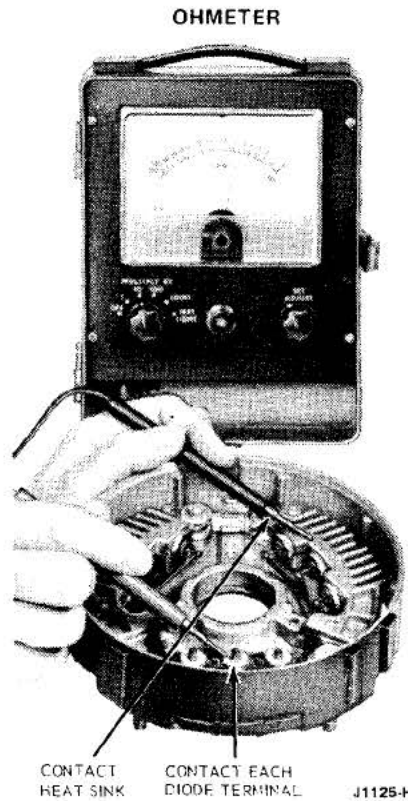

FIG. 8 Diode Test—Leece Neville Alternator

stator winding is shorted to the core and must be replaced. Repeat this test for each of the stator leads.

Rotor Open or Short Circuit Test

Disassemble the front housing and rotor from the rear housing and stator as outlined under Disassembly in the appropriate alternator part in Group 31. Set the ohmmeter Multiply By knob at 1 and calibrate the meter as directed inside the ohmmeter cover.

1. Contact each ohmmeter probe to a rotor slip ring (Fig. 9). The meter reading should be 2.4 to 4.9 ohms. A higher reading indicates a weak or

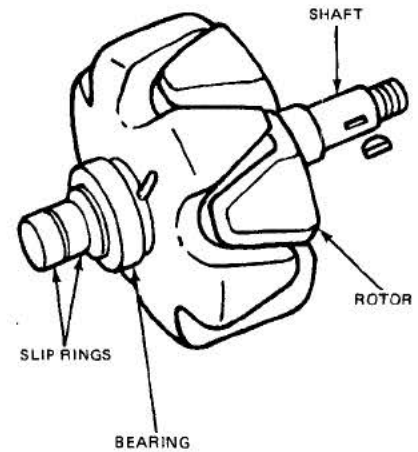

J2022-A

FIG. 9 Rotor Assembly—Typical

broken slip ring solder connection or a broken wire. A lower reading indicates a shorted wire or slip ring. Replace the rotor if it cannot be repaired.

2. Contact one ohmmeter probe to a slip ring and the other probe to the rotor shaft. The meter reading should be infinite (no deflection).
3. A reading other than infinite indicates the rotor is shorted to the shaft. Inspect the slip ring soldered terminals to be sure they are not bent and touching the rotor shaft, or that excess solder is not grounding the rotor coil connections to the shaft. Replace the rotor if it is shorted and cannot be repaired.

CHARGING SYSTEM FUSE LINK

Fuse links are included in the charging system wiring on some vehicles. Refer to Part 34-31 for fuse link repair procedures.

100% SATISFACTION GUARANTEED

BUY IT NOW!

Click Here To Order

PayPal American Express Cards Discover Novus MasterCard VISA

<h1>Batteries</h1>		PART 31-02	
APPLIES TO ALL MODELS			
SUBJECT	PAGE	SUBJECT	PAGE
GENERAL INFORMATION	02-1	TESTING (Cont'd.)	
Jump Start	02-1	Tests Using Rotunda Battery-	
TESTING	02-1	Starter Tester or Equivalent	02-1
Tests Using Christie or Equivalent	02-1	SPECIFICATIONS	02-3

GENERAL INFORMATION

DANGER—EXPLOSIVE GASES
Batteries produce explosive gases. Keep sparks, flame and cigarettes away, ventilate when charging or using in enclosed space. Always shield eyes when working near batteries.

POISON—CAUSES SEVERE BURNS Batteries contain sulphuric acid. Avoid contact with skin, eyes, or clothing. Antidote: External - Flush with water. Eyes: Flush with water for 15 minutes and get prompt medical attention. Internal: Drink large amounts of water or milk, follow with Milk of Magnesia, beaten egg or vegetable oil. Call Physician immediately. Keep out of the reach of children.

Jump Start

When starting vehicles with another battery and jumper cables, the following instructions should be followed to prevent

sparks at the battery terminals and to prevent damage to other electrical components on the vehicle.

1. Be sure the ignition key is in OFF position.
2. Shield eyes. Use safety goggles or similar eye protection.
3. Place damp cloth across the tops of both batteries.
4. Connect ends of one cable to positive (+) terminals of each battery.
5. Connect one end of the other cable to negative (-) terminal of "good" battery.
6. Connect other end of cable to engine bolthead or similar good contact spot on the vehicle being started (NOT to negative (-) terminal of battery).
7. To prevent damage to other electrical components on vehicle being started,

make certain that engine is at idle speed before disconnecting jumper cables.

NOTE: Batteries are heavy, weighing 25 lbs and up. Lift them with your legs rather than your back to prevent muscle strains, and be careful not to drop them (possible breakage) nor to spill the contents (sulfuric acid).

NOTE: Twelve-volt starting motors can be damaged beyond repair if connected to a 24-volt power supply (two 12-volt batteries in series, or a 24-volt motor-generator set), even when cranking loads are relatively light. Extensive starting motor damage is more likely if the starter is connected to a 24-volt supply while being subjected to prolonged heavy cranking loads such as attempting to start an engine in subzero temperatures.

TESTING

Tests are made on a battery to determine the state of charge and also the condition. The ultimate result of these tests is to show that the battery is good, needs recharging, or must be replaced.

If a battery has failed, is low in charge, or requires water frequently, good service demands that the reason for this condition be found. It may be necessary to follow trouble shooting the

damaged. Possible battery damage with replacement often necessary is indicated by moisture on the outside of the case (possible cracked and leaking case) and/or low electrolyte level in one or more cells (possible leak or weak cell).

Original equipment batteries incorporate a single one-piece cover which completely seals the top of the battery and the individual cell connectors. This cover must not be pierced with test probes to perform individual cell tests.

TESTS USING CHRISTIE OR EQUIVALENT

Follow the instructions that come with the unit.

TESTS USING THE ROTUNDA BATTERY-STARTER TESTER OR EQUIVALENT

Battery Capacity Test (Fig. 1)

A high rate discharge tester (Rotunda Battery-Starter Tester or equivalent) in conjunction with a voltmeter is used for this test.

1. Turn the control knob on the Battery Starter Tester to the OFF position.
2. Turn the voltmeter selector switch to the 20-volt position.
3. Position the selector switch to "AMP".
4. Adjust the load control knob until the ammeter reading corresponds to the

100% SATISFACTORY GUARANTEED

BUY IT NOW!

Click Here To Order

PayPal Discover MasterCard VISA

NON-MAINTENANCE FREE BATTERY CAPACITY TEST

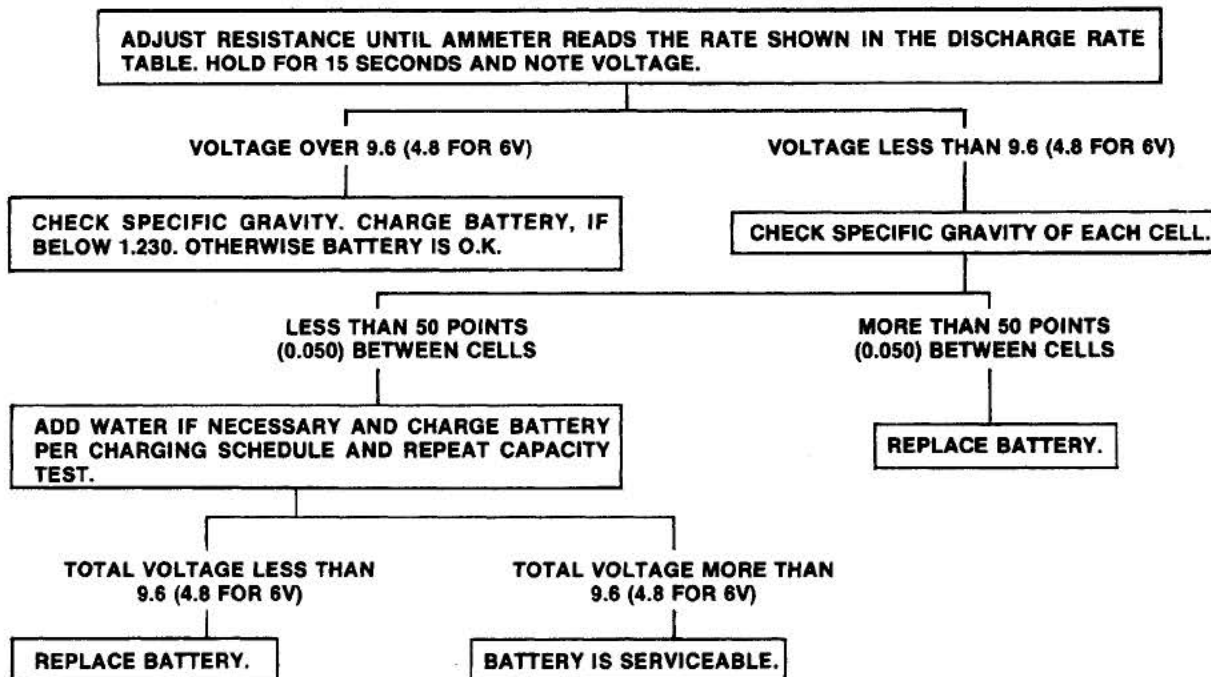

MAINTENANCE FREE BATTERY CAPACITY TEST

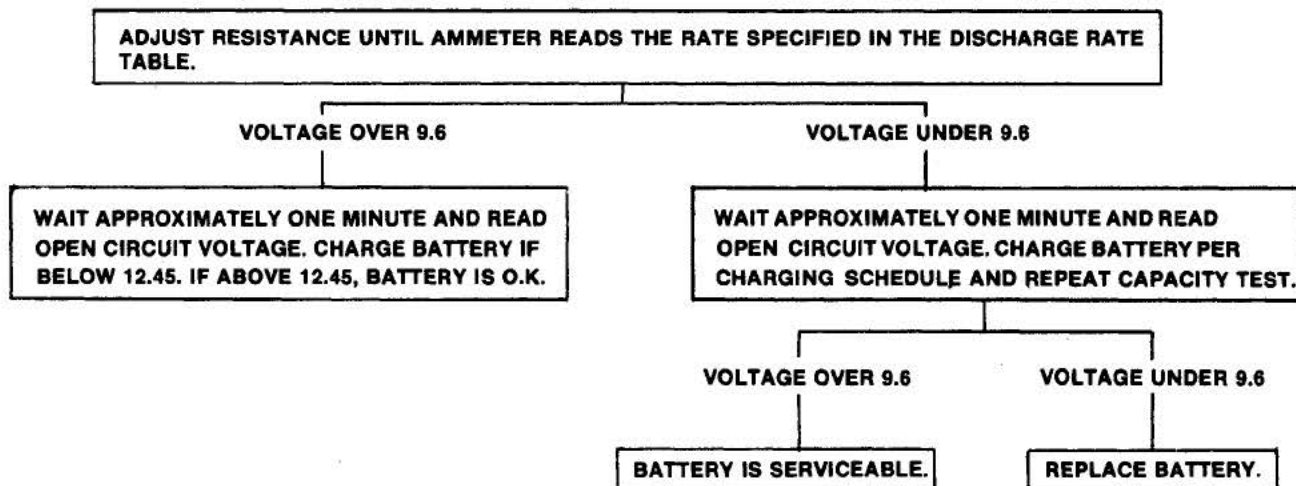

CJ1039-G

FIG 1. Battery Capacity Test Outline rate shown in the battery discharge rate table.

required. Check the state of charge by reading the specific gravity of a Non-Maintenance Free Battery or the open circuit voltage of a Maintenance Free Battery. If the open circuit voltage is below 12.45, charge the battery according to the battery charge time schedule.

7. If the voltage reading obtained during the capacity test of a Non-Maintenance Free Battery is below 9.6 volts for a 12-volt battery and 4.8 volts for a 6-volt battery, check the specific gravity of each cell.

If the difference between any two cells is more than 50 points (0.050), the battery is not satisfactory for service and should be replaced.

Always disconnect the battery ground cable when charging the battery.

100% SATISFACTION GUARANTEED

BUY IT NOW!

Click Here To Order

PayPal

Discover

MasterCard

VISA

battery has good output capacity and will readily accept a charge, if

If the difference between cells is less than 50 points (0.050), the battery should be charged according to the charging schedule in the Specifications Section.

In some cases the electrolyte level may be too low to obtain a specific gravity reading. In such cases, water should be added until the electrolyte level just covers the ring in the filler well, then charge the battery at 35 amperes for the maximum charging time indicated in Specifications for the capacity of the battery being tested.

Batteries that are completely discharged may not accept a fast charge. If this is found, the battery should be slowly charged at 4 amps for (2) hours so the battery will be capable of accepting a fast charge. A specific gravity reading taken at this time will show no change from the original reading and the battery must be charged accord-

ing to the high rate charge time schedule.

8. If the voltage reading obtained during the capacity test on a Maintenance Free Battery is below 9.6 volts, check the open circuit voltage approximately one minute after the capacity test. Charge the battery according to the charge time schedule for Maintenance Free Batteries.
9. After the battery has been charged, repeat the capacity test. If the capacity test battery voltage is still less than 9.6 volts, replace the battery. If the voltage is 9.6 volts or more, the battery is satisfactory for service.
10. If the battery is found to be discharged only, check for a loose fan belt, loose electrical connections and charging system performance.

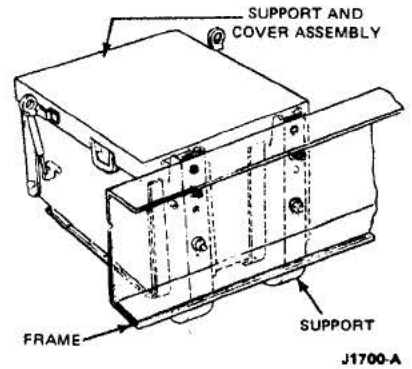

FIG. 2 Typical Heavy-Duty (2 12-Volt) Battery Box

SPECIFICATIONS

Non-Maintenance Free Battery Discharge Rates	
Battery Capacity Ampere Hours	Discharge Rate Amperes
41	145
53	175
55	175
68	220
70	210
77	225
81	200
95	290
155	350
158 (6V)	350
172 (6V)	415
204	440

CJ2023-A

Maintenance Free Battery Discharge Rate	
Battery Capacity Ampere Hours	Discharge Rate Amperes
68	235

CJ2024-A

100% SATISFACTION GUARANTEED

BUY IT NOW!

Click Here To Order

PayPal American Express Discover MasterCard VISA

NON-MAINTENANCE FREE BATTERY HIGH RATE CHARGE TIME SCHEDULE										
Specific Gravity Reading	Charge Rate Amperes	Battery Capacity Ampere Hours								
		41	53-55	68-70	95	155	158(6-V)	204	172(6V)	77-81
1.125-1.150 ①	35	65 min	80 min	100 min	135 min	225 min	225 min	300 min	250	115 min.
1.150-1.175	35	50 min	60 min	80 min	105 min	175 min	175 min	230 min	190	95 min.
1.175-1.200	35	40 min	50 min	60 min	85 min	140 min	140 min	185 min	155	70 min.
1.200-1.225	35	30 min	35 min	45 min	60 min	100 min	100 min	135 min	110	50 min.
Above 1.225	5	②	②	②	②	③	③	③	③	②

① If the specific gravity is below 1.125, use the time indicated for the 1.125 specific gravity, then charge at 5 amperes until the specific gravity reaches 1.250 at 80°F.

② Charge at 5 ampere rate only until the specific gravity reaches 1.250 at 80°F.

③ Charge at 10 ampere rate only until the specific gravity reaches 1.250 at 80°F.

At no time during the charging operation should the electrolyte temperature exceed 130°F.

CJ1645-D

MAINTENANCE FREE BATTERY ALLOWABLE BATTERY CHARGE TIME SCHEDULE — 68 A.H. BATTERY

Open Circuit Voltage	Charge Rate — Amperes			
	5	10	20	30
Below 11.85	13 hrs.	6.5 hrs.	3.25 hrs.	2 hrs.
11.85-12.00	10 hrs.	5 hrs.	2.5 hrs.	1.5 hrs.
12.00-12.10	8 hrs.	4 hrs.	2 hrs.	1.25 hrs.
12.10-12.25	6 hrs.	3 hrs.	1.5 hrs.	1 hr.
12.25-12.35	4 hrs.	2 hrs.	1 hr.	30 min.
Above 12.35	2.5 hrs	—	—	—

CAUTION: Do not exceed 30 ampere charge rate.

CJ2025-A

If gassing or spewing of the electrolyte occur during charging, the charge rate must be reduced.

100% SATISFACTION GUARANTEED

BUY IT NOW!

Click Here To Order

PayPal, Discover, MasterCard, VISA

Motorcraft

1973 / 79

Truck Master Parts and Accessories Catalog (100-500 Series)

Source Document
Extract Only
Sections 103 thru 145

FORD MOTOR COMPANY

Dearborn, Michigan



BUY IT NOW!

Click Here To Order 



April 1980



License #2011747

MASTER PARTS AND ACCESSORIES CATALOG

(ILLUSTRATIONS)

FORD DIVISION

GENERAL INSTRUCTIONS

This Ford Truck Master Parts Catalog contains parts illustrations for truck series B500, E100/300, F100/500 and P350/500 for model year 1973 for U.S. and Canadian built vehicles.

Use these ILLUSTRATIONS in conjunction with the TEXT in the front portion of the catalog.

For greater convenience this catalog is divided into specific sections such as brakes, front suspension, engine, transmission, etc. For example, FRONT SUSPENSION appears in Section 30, STEERING in Section 35, REAR AXLE in Section 40, etc.

The TEXT portion of the catalog is divided into sections also and like parts are shown under similar section numbers in both the TEXT and ILLUSTRATION portions of the catalog.

A listing of Ford group numbers and their related section numbers appears in the General Information Section of the TEXT portion of the catalog.

Illustrations contain group numbers only, therefore, it is necessary to refer to the group within the TEXT portion of the catalog listing for complete applicable part number.

The driver's side is the left hand side of the vehicle and determines whether such parts as fenders, lamps, etc. are right or left hand.

Model year application is indicated by showing the first year followed by a diagonal line to indicate continued usage in all subsequent years until the insertion of the last year of usage, which is shown after the diagonal line. If no diagonal line is shown the part is applicable only to the year shown.

Example.

- 73/ indicates part used 1973 through subsequent models.
- 73/74 indicates part used 1973 through 1974 model years.
- 73 indicates part used 1973 model year only.

For Warranty Plate Data, Catalog Model Codes and Body Type Codes refer to the General Information Section of the TEXT portion of the catalog.

SYMBOLS COMMONLY USED IN THIS CATALOG

- * identifies Motorcraft Sales Number.
- # indicates some form of Identification.
- ★ indicates Not Serviced-must be improvised or procured locally.

MODEL CODES

Truck models are listed throughout this catalog by truck series. A listing of series codes shown on Warranty Plates is included in the General Information Section of the TEXT portion of the catalog. Refer to these codes to determine the series listed in this catalog. Model application is often consolidated as shown below:

Example:

- F100/350 means F100 thru F350 or F100, F250 and F350.
- and: B-F500 means B500 and F500.

100% SATISFACTION GUARANTEED

BUY IT NOW!

Click Here To Order

PayPal American Express DISCOVER MasterCard VISA

1973/79 TRUCK SERIES 100/500

CHASSIS PARTS ILLUSTRATION INDEX

Following is a general index of the major groups shown in the Chassis and Body Parts Illustration Sections. For more specific information refer to the Index appearing in front of the Section number listed below:

MAJOR GROUP	● TABBED DIVIDER TITLE	INDEX SECTION
Accelerator Linkage	Fuel	90
Accessories	Listed in their appropriate groups as identified in this index	
Air Cleaner	Fuel	90
Air Conditioner	Air Cond.-Heaters-Radios-Shock Absorbers	180
Alternator	Generator-Alternator-Starter-Distributor	103
Automatic Transmission	Automatic Transmission	A70
Axle (Front)	Front Axle-Steering	30
Axle (Rear)	Rear Axle	40
Battery	Generator-Alternator-Starter-Distributor	103
Battery Carriers	Generator-Alternator-Starter-Distributor	103
Brake System	Wheel-Brake	10
Bumpers	Bumpers-Mirrors-Speedo. Cable-Tow Hooks-Wipers-Washers	175
Camshaft	Engine	60
Carburetor	Fuel	90
Carrier (Wheel)	Wheel-Brake	10
Clutch	Transmission-Clutch	70
Cooling System	Cooling-Grille	80
Coupling Shaft	Driveshaft-Coupling Shaft	40
Crankcase Vent System	Engine	60
Cylinder Block	Engine	60
Cylinder Head and Valves	Engine	60
Distributor	Generator-Alternator-Starter-Distributor	103
Driveshaft	Driveshaft-Coupling Shaft	40
Electrical	Generator-Alternator-Starter-Distributor	103
Electrical	Lamps-Wiring	130
Emission Control (Thermactor)	Fuel	90
Engine	Engine	60
Engine Supports	Engine	60
Exhaust System	Frames-Muffler-Exhaust	50
Fan	Cooling-Grille	80
Fenders	Fender-Hood	180
Frame	Frame-Muffler-Exhaust	50
Front Axle	Front Axle-Steering	30
Front Springs	Spring-Rear Suspension	50
Front Suspension	Front Axle-Steering	30
Fuel Filter	Fuel	90
Fuel Pump	Fuel	90
Fuel System	Fuel	90
Fuel Tank	Fuel	90
Gearshift Lever	Transmission-Clutch	70
Grille	Cooling-Grille	80

● Applicable to Loose Leaf Catalogs only.



BUY IT NOW!

Click Here To Order 



1973/79 TRUCK SERIES 100/500



CHASSIS PARTS ILLUSTRATION INDEX cont'd

MAJOR GROUP	• TABBED DIVIDER TITLE	INDEX SECTION
Heater	Air Cond.-Heaters-Radios-Shock Absorber	180
Hood	Fender-Hood	160
Horn	Lamps-Wiring	130
Hubs	Wheel-Brake	10
Ignition System	Generator-Alternator-Starter-Distributor	103
Instrument Cluster	Generator-Alternator-Starter-Distributor	103
Lamps	Lamps-Wiring	130
Lever (Gearshift)	Transmission-Clutch	70
Manifolds	Fuel	90
Mirrors	Bumpers-Mirrors-Speedo. Cable-Tow Hooks- Wipers-Washers	175
Muffler	Frame-Muffler-Exhaust	50
Oil Pump	Engine	60
Piston and Connecting Rod	Engine	60
Pump (Fuel)	Fuel	90
Pump (Oil)	Engine	60
Pump (Water)	Cooling-Grille	80
Radiator	Cooling-Grille	80
Radios	Air Cond.-Heaters-Radios-Shock Absorbers	180
Rear Axle	Rear Axle	40
Rear Springs	Springs-Rear Suspension	50
Shaft (Coupling)	Driveshaft-Coupling Shaft	40
Shock Absorbers	Air Cond.-Heaters-Radios-Shock Absorber	180
Spare Wheel Carrier	Wheel-Brake	10
Speedo. Cable	Bumpers-Mirrors-Speedo. Cable-Tow Hooks- Wipers-Washers	175
Springs	Springs-Rear Suspension	50
Stabilizer (Front)	Front Axle-Steering	30
Starter	Generator-Alternator-Starter-Distributor	103
Steering	Front Axle-Steering	30
Steering Wheel	Front Axle-Steering	30
Suspension (Front)	Front Axle-Steering	30
Suspension (Rear)	Springs-Rear Suspension	50
Tank (Fuel)	Fuel	90
Tow Hooks	Bumpers-Mirrors-Speedo. Cable-Tow Hooks- Wipers-Washers	175
Thermostatic Choke Control	Fuel	90
Transfer Case	Transmission-Clutch	70
Transmission (Automatic)	Automatic Transmission	A70
Transmission (Manual)	Transmission-Clutch	70
Valves, Push Rods and Covers	Engine	60
Voltage Regulator	Generator-Alternator-Starter-Distributor	103
Water Pump	Cooling-Grille	80
Wheels	Wheels-Brakes	10
Windshield Wiper and Washers	Bumpers-Mirrors-Speedo. Cable-Tow Hooks- Wipers-Washers	175
Wiring	Lamps-Wiring	130

• Applicable to Loose Leaf Catalogs only.
October, 1979

COPYRIGHT © 1979 — FORD MOTOR COMPANY — DEARBORN, MICHIGAN

NEW ISSUE

**GENERAL
INFORMATION**

**1973/79
TRUCK SERIES 100/500**

BODY PARTS ILLUSTRATION INDEX



MAJOR GROUP	TABBED DIVIDER TITLE	INDEX SECTION
American Road Camper Parts	Recreational Vehicles	Refer to text catalog
Back Door	Body Parts	Δ
Door Parts	Body Parts	Δ
Exterior Trim	Sheet Metal-Exterior Mldg.-Interior Trim	Δ
Interior Trim	Sheet Metal Exterior Mldg.-Interior Trim	Δ
Platform and Racks	Sheet Metal-Exterior Mldg.-Interior Trim	Δ
Seats	Body Parts	Δ
Sheet Metal	Sheet Metal-Exterior Mldg.-Interior Trim	Δ
Storage Compartment	Body Parts	Δ
Windows (Back and Side)	Body Parts	Δ
Windshield	Body Parts	Δ

HOW TO USE THIS CATALOG

There are three ways of finding part numbers if the group number is not known.

1. By Part Name
2. By Illustration
3. By Identification

Should an inquiry be received for a radiator grille for a 1978 F100:

BY PART NAME -

- A. Refer to the Chassis Parts Alphabetical Index in the Text Catalog, form FPS 8096-A.
- B. Refer to the alphabetical nomenclature and find the part name "Grille (radiator)".
The group number listed is 8200.
- C. Refer to group number 8200 and locate 1973 in the "YEAR" column. Find the series F100/350 in the "MODEL/RESTRICTIONS" column.
- D. The part number shown is D5TZ 8200-A.

BY ILLUSTRATION -

- A. Refer to the tabbed divider marked "COOLING-GRILLE" in this catalog.
- B. Refer to the index immediately behind the divider and find the illustration titles for the F Series.
- C. Under the heading "RADIATOR GRILLE and RELATED PARTS" find the "Grille" illustration for the 1973 F100.
- D. Refer to the illustration designated (on page 2 of Illustration Section 82) and find the group number for the grille to be 8200.
- E. Refer to group number 8200 in the Text Catalog and locate 1973 in the "YEAR" column. Find the series F100/350 in the "MODEL/RESTRICTIONS" column.
- F. The part number shown is D5TZ 8200-A.

BY IDENTIFICATION -

Certain parts and most major assemblies are identified with a part number shown on an attached tag or plate or on the part itself. Reference to identification numbers is made throughout the catalog and cross reference charts are included in some sections to provide immediate knowledge of the service part number when the identification number is known. All identification information other than charts will be preceded by the symbol (#).

IMPORTANT - Identification tags and plates must be retained with the part or assembly with which they are originally supplied.

-
- Applicable to Loose Leaf Catalogs only.
 - Δ Refer to Index Section in front of Body Illustrations.

**1973/79
TRUCK SERIES 100/500**

**GENERAL
INFORMATION**

5

HOW TO ORDER PARTS

When ordering parts, always give the complete part number.

In the event the part number is not known, the following information should be included.

- A. Complete description of part.
- B. Model year and body type.
- C. Dimension, number of teeth, size, etc., if possible rough sketch of part.
- D. If applicable to engine, transmission, axle, steering, etc., specify type, such as 302 cubic inch, Automatic Transmission, Power Steering, etc.
- E. Advise how shipment is to be made - Freight, Express, Air, Parcel Post.

EXPLANATION OF SYMBOL *

*Symbol indicates part is not supplied for service due to the following:

- a. Part is superseded and replaced as indicated in the description column of the text catalog.
- b. Part can be improvised as indicated in the description column of text catalog.
- c. Due to its function there would be little or no demand.

NOTE - ALWAYS REFER TO THE DESCRIPTION COLUMN OF THE TEXT FOR POSSIBLE SUBSTITUTION, OR FOR MATERIAL SPECIFICATIONS AND DIMENSIONS WHICH MAY BE HELPFUL IN OBTAINING THE NON-SERVICED PART LOCALLY.



BUY IT NOW!

Click Here To Order



PayPal

Discover
Cards

DISCOVER
NOWUS

MasterCard

VISA

COPYRIGHT © 1979 — FORD MOTOR COMPANY — DEARBORN, MICHIGAN

NEW ISSUE

1973/79 TRUCK SERIES 100/500

ILLUSTRATION
SECTION 103

A

INDEX

INCLUDED IN THIS INDEX ARE THE FOLLOWING MAJOR GROUPS IN THE ORDER SHOWN BELOW

ALTERNATOR
BATTERY CARRIER
DISTRIBUTOR
EMISSION SYSTEM

GOVERNOR ASSY.
IGNITION WIRING
INSTRUMENT CLUSTER
STARTER
VOLTMETER

YEAR 19__	TITLE	SECTION	PAGE	ILLUS. NO.
ALTERNATORS				
73/	Alternator-Ford 38, 40, 42, 55, 60 and 61 amp.	103	1	P-4508
73/	Alternator-Ford 70 amp.	103	2	P-5394
75/	Alternator-Motorcraft 90, 100 amp.	103	3	P-10328
76/	Alternator mounting brackets-- F100, E100-6 cyl. 300	103	4	P-12724
76/	Alternator mounting brackets-- F100-8 cyl. 302	103	4	P-12725
76/	Alternator mounting brackets-- E250/350-8 cyl. 460	103	5	P-12726
76/	Alternator mounting brackets-- F150/350-8 cyl. 460	103	5	P-12727
76	Alternator mounting brackets-- F100/350-8 cyl. 360, 390-with T/E	103	6	P-12728
76	Alternator mounting brackets-- F100/350-8 cyl. 360, 390-without T/E	103	6	P-12729

YEAR 19__	TITLE	MODEL	SECTION	PAGE	ILLUS. NO.
BATTERY CARRIERS					
73/74	Battery carrier and related parts	E100/300	106	10	P-6723
75/	Battery carrier and related parts--6 cyl. eng.	E100/350	106	13	P-12096
75/	Battery carrier and related parts--8 cyl. eng.	E100/350	106	14	P-12097
73/	Battery carrier and related parts	F100/350	106	9	P-5307
73/77	Battery carrier and related parts-typical	B-F500	106	9	P-5786
73/77	Battery carrier and related parts	P350/500	106	10	P-11936
73/	Battery carrier and related parts (L. H. fender-mounted-auxiliary battery)	F100/350--w/dual battery	106	12	P-10751
73/76	Battery carrier and related parts	M450/500	106	12	P-11421

YEAR 19__	TITLE	SECTION	PAGE	ILLUS. NO.
DISTRIBUTORS				
73/	Distributor (conventional)--6 cyl. eng.	120	1	P-10451
73/	Distributor (conventional)--8 cyl. eng.	120	2	P-9288
74/	Distributor (breakerless)--8 cyl. eng.	120	3	P-11057
74	Distributor (breakerless)--6 cyl. eng.	120	3	P-11057
75/	Distributor (breakerless)--6 cyl. eng.	120	4	P-12857

DISTRIBUTOR VACUUM HOSES				
78/	Distributor vacuum hoses-- F150-8 cyl. 302-exc. Calif.	120.2	1	P-14306

EMISSION SYSTEM				
Emission system - exhaust gas recirculation (E.G.R.)				
--Refer to emissions in Illustration Index 90 Section 94.1				

COPYRIGHT © 1979

FORD MOTOR
COMPANY

—DEARBORN, MICHIGAN

NEW ISSUE



BUY IT NOW!

Click Here To Order



B

**ILLUSTRATION
SECTION 103**

**1973/79
TRUCK SERIES 100/500**

INDEX



YEAR 19__	TITLE			
IGNITION WIRING				
73/77	Ignition wiring (conventional distributor) system-typical--B-E-F-P100/500-6 cyl. 240 and 300	120.1	2	P-8239
73/	Ignition wiring (conventional distributor system-typical--E-F100/350-6 cyl. 240 and 300	120.1	2	P-8239
73/74	Ignition wiring (conventional distributor) system-typical--E100/300 and F100-8 cyl. 302	120.1	3	P-8240
73/74	Ignition wiring (conventional distributor) system-typical--F100/350-8 cyl. 360 and 390	120.1	4	P-8244
73/74	Ignition wiring (conventional distributor) system-typical--B-F500-8 cyl. 330 M/D	120.1	5	P-8241
74/	Ignition wiring (breakerless distributor) system-typical--B- F500, P350/500-6 cyl.300	120.1	6	P-11780
74/	Ignition wiring (breakerless distributor) system-typical--F100-8 cyl. 302	120.1	7	P-11781
74/75	Ignition wiring (breakerless distributor) system-typical--F100/350-8 cyl. 360 and 390	120.1	8	P-11782
74/	Ignition wiring (breakerless distributor) system-typical--F100/350-8 cyl. 460	120.1	9	P-11783
GOVERNOR ASSEMBLY				
73/	Governor assy.-velocity type-typical--6 cyl. 300	120.1	1	P-6700
INSTRUMENT CLUSTERS				
73/74	Instrument cluster and related parts--E100/300	106	1	P-8999
75/	Instrument cluster and related parts--E100/350-w/gauges	106	7	P-11626
75/	Instrument cluster and related parts--E100/350-w/warning lights	106	8	P-11627
73/	Instrument cluster and related parts--F100/350(81)-w/warning lights	106	2	P-10168
73/	Instrument cluster and related parts--F100/350(81)-w/gauges	106	3	P-10167
73/	Instrument cluster and related parts--F350	106	4	P-8967
73/77	Instrument cluster and related parts--B-F500	106	4	P-8967
73/77	Instrument cluster and related parts--F500 (81)	106	5	P-7136
73/77	Instrument cluster and related parts--P350/500	106	6	P-3557
STARTERS				
Starter and drive assy.-Ford positive engagement				
73/77	- w/o integral solenoid w/side cable attachment	110	1	P-3191
73/77	- w/integral solenoid w/side cable attachment	110	2	P-5952
77/	- w/o integra. solenoid w/rear cable attachment	110	3	P-13469
VOLTMETER				
73/77	B500	106	11	P-10251

ALTERNATOR-FORD 38, 40, 42, 55, 60 and 61 AMP.
1973/

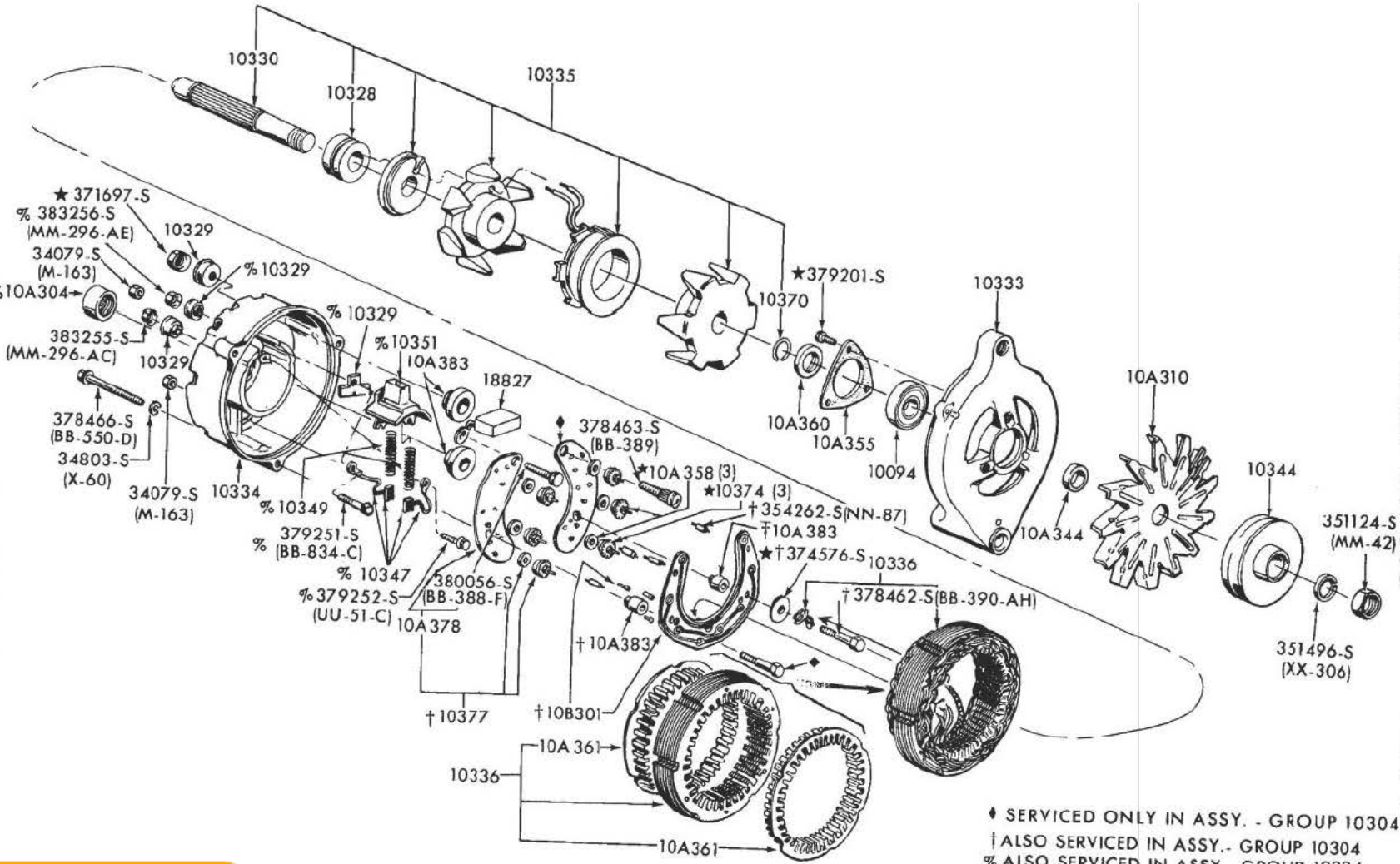

1973/79
TRUCK SERIES 100/500

ILLUSTRATION
SECTION 103

♦ SERVICED ONLY IN ASSY. - GROUP 10304
† ALSO SERVICED IN ASSY. - GROUP 10304
% ALSO SERVICED IN ASSY. - GROUP 10334

P-4508

100% SATISFACTION GUARANTEED

BUY IT NOW!

Click Here To Order

**1973/79
TRUCK SERIES 100/500**

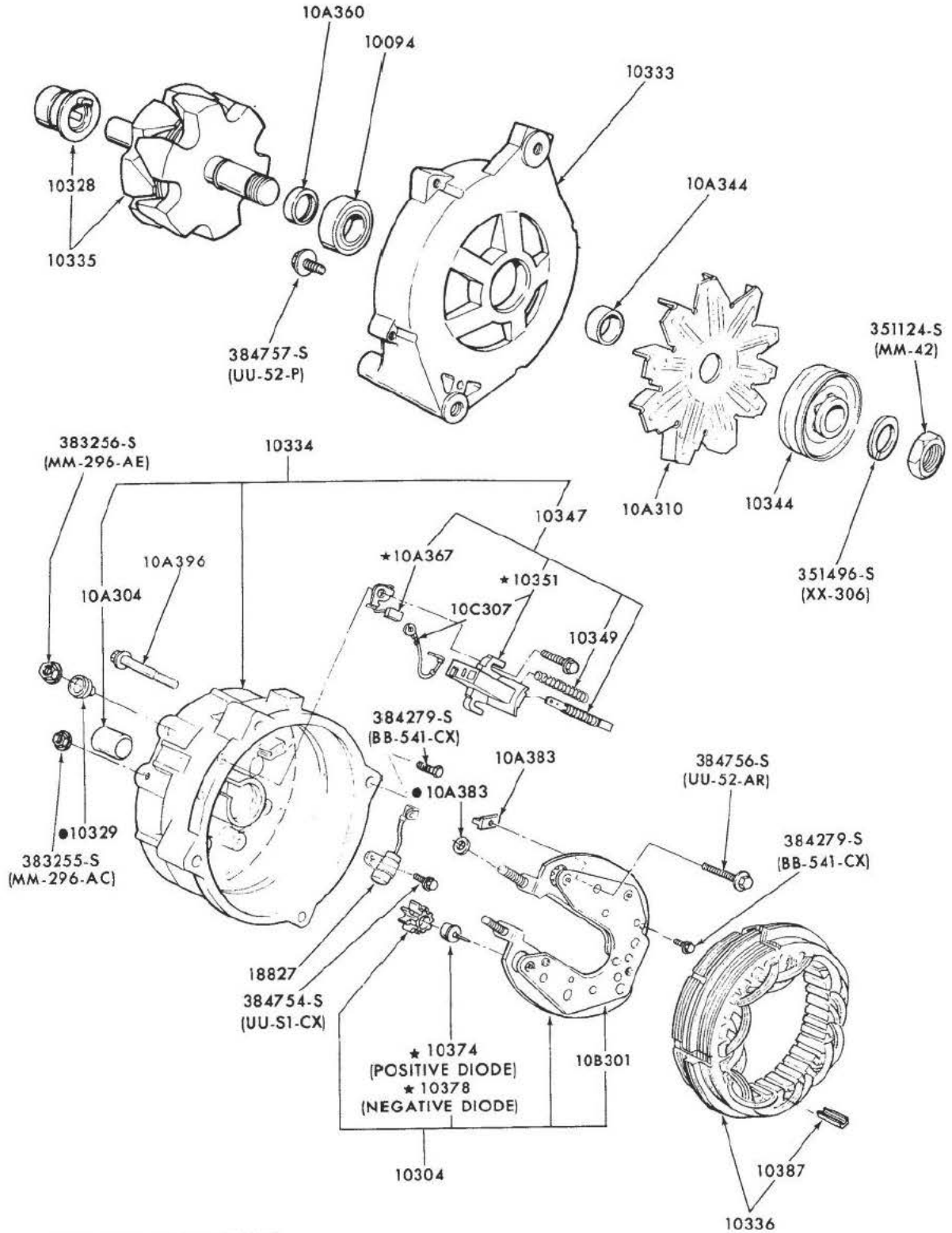

● ALSO PART OF 10A383 KIT

P-10328

ALTERNATOR - MOTORCRAFT 90 and 100 AMP.
1975/

COPYRIGHT © 1979 - FORD MOTOR - DEARBORN, MICHIGAN
COMPANY

NEW ISSUE



BUY IT NOW!

Click Here To Order



1973/79 TRUCK SERIES 100/500

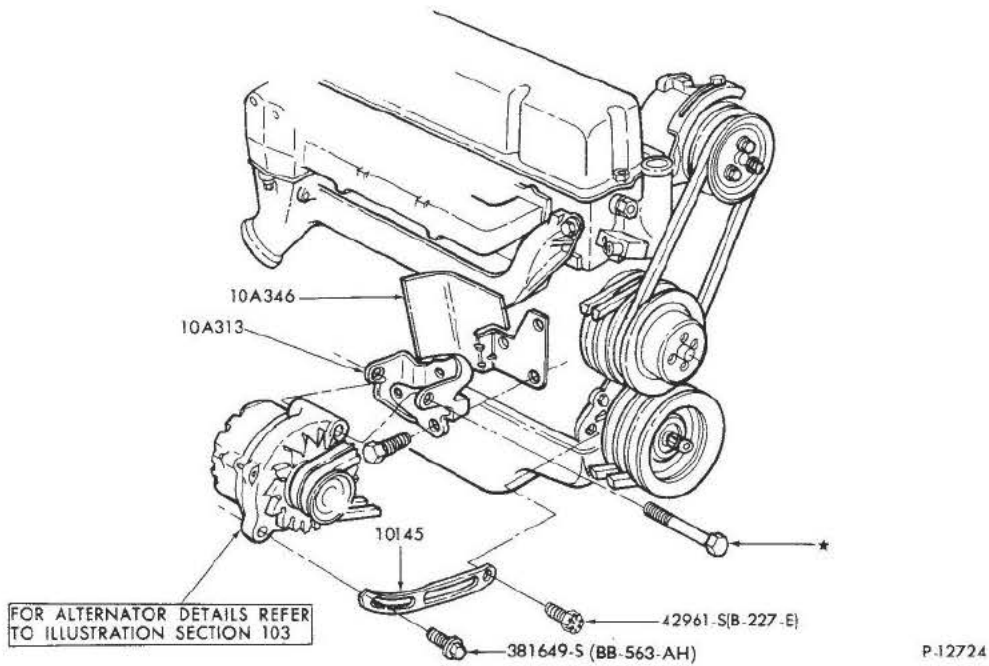

ALTERNATOR MOUNTING BRACKETS
1976/ F100 and E100--6 CYL. 300

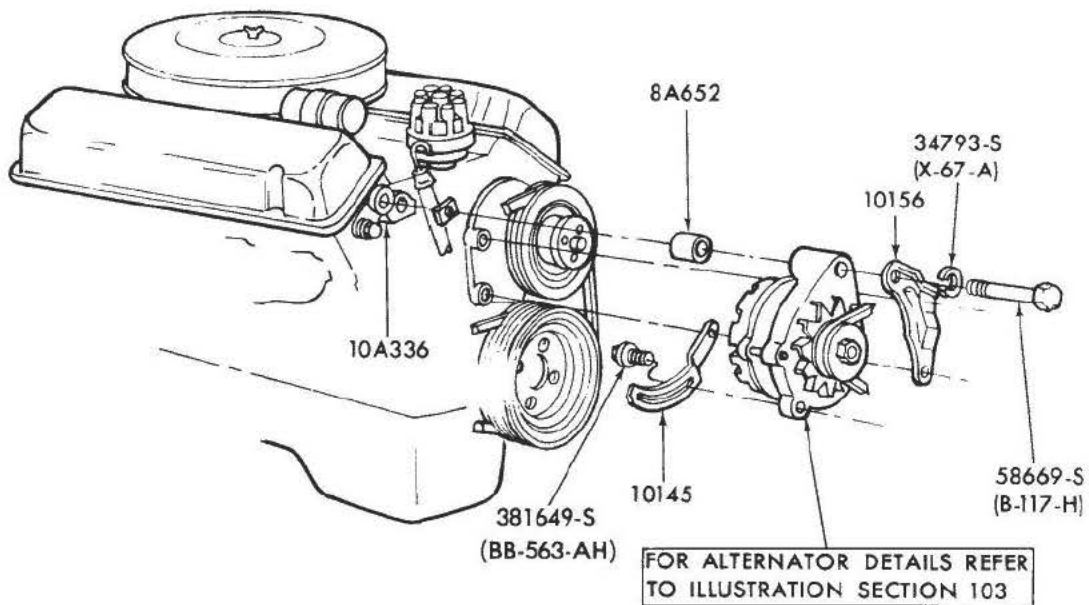

ALTERNATOR MOUNTING BRACKETS
1976/ F100--8 CYL. 302



BUY IT NOW!

Click Here To Order



1973/79 TRUCK SERIES 100/500

ILLUSTRATION
SECTION 106

1

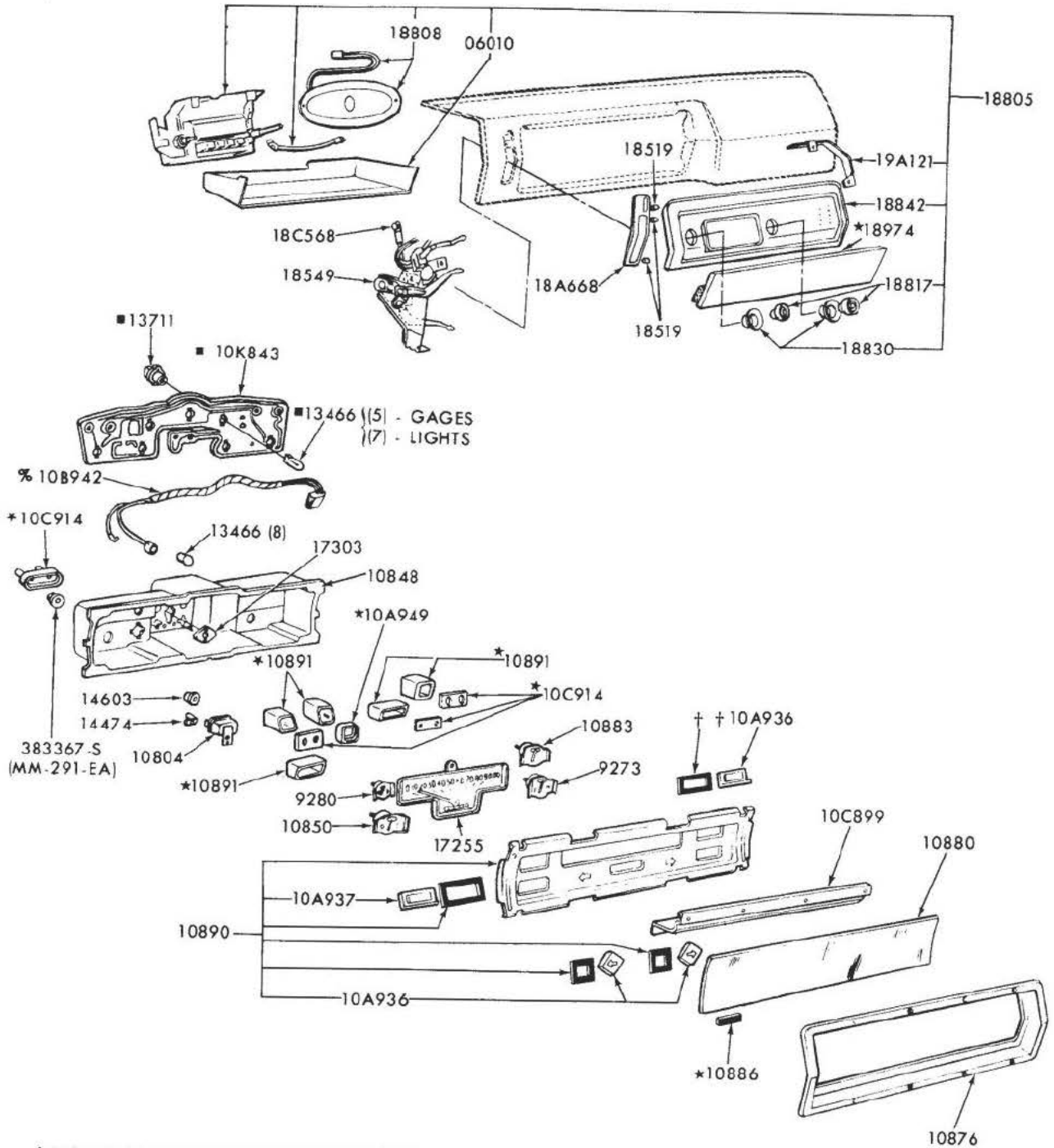

† ALSO SUPPLIED IN 10890 MASK ASSEMBLY
■ 1970/
% 1969

P-8999



BUY IT NOW!

Click Here To Order

INSTRUMENT CLUSTER and RELATED PARTS
1973/74 E100/300

COPYRIGHT © 1979 FORD MOTOR COMPANY - DEARBORN, MICHIGAN

NEW ISSUE





READY REFERENCE

13001

HOW TO READ WIRING DIAGRAMS



VOL 68 S7 L2A

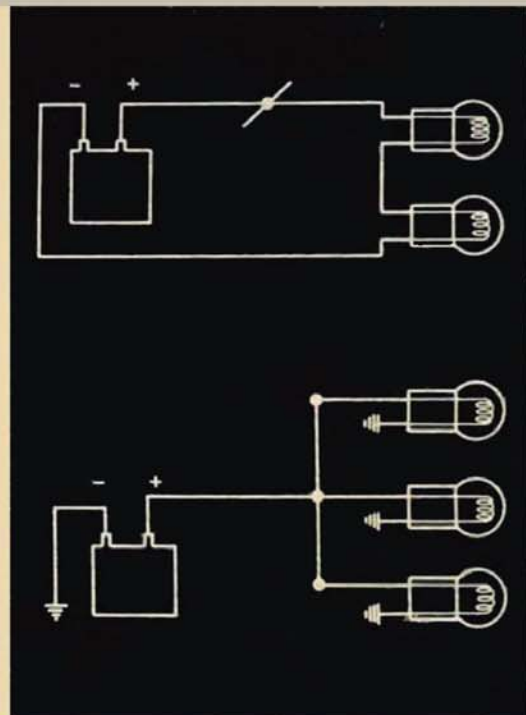

BUY IT NOW!

Click Here To Order



HOW TO READ WIRING DIAGRAMS

COURSE 13001 • VOL. 68 S7 L2A

TABLE OF CONTENTS

Page

INTRODUCTION

A LOGICAL APPROACH TO ELECTRICAL DIAGNOSIS	1
Like reading a road map	2
How wires are numbered and color-coded	2
CIRCUIT – A COMPLETE ELECTRICAL PATH BETWEEN TWO POINTS	5
2-wire circuit	6
Single wire circuit	6
Ground connections	7
OPEN CIRCUITS	8
Shorts	9
Grounded circuit	9
Series and parallel open circuits	10
BREAKS IN PARALLEL CIRCUITS	11
Common points	14
Splices	15
Fuses and circuit breakers	17
Quick disconnects	18
Male and female elements	20
Types of quick disconnects	22
HINTS FOR TRACING WIRES THROUGH A DRAWING	23
Curve directions	23
Common points	24
Switches	25
Relays	26
Assemblies	28
Locating the assembly	29
Finding the wire	30
SUMMARY	31

100% SATISFACTION GUARANTEED

BUY IT NOW!

Click Here To Order

The descriptions, testing procedures, and specifications in this handbook were approved for printing. Ford Motor Company reserves the right to change specifications without notice and without incurring

NATIONAL SERVICE OFFICE
FORD DIVISION



FIRST PRINTING – JANUARY, 1968

© 1968 FORD MOTOR COMPANY
DEARBORN, MICHIGAN

INTRODUCTION

The Why and Wherefore of Wiring Diagrams

To the uninformed, a wiring diagram — or a wiring assembly — looks like it might take a genius to figure out.

Not so — as you'll find out when you get better acquainted with these subjects.

There're as understandable and logical as a road map and road markers, when you're finding your way on a cross-country drive.

The ability to read a wiring diagram and relate it to a vehicle's wiring system is, of course, an essential part of a modern service technician's skill. And it's growing in relative importance, too, due to owner's increasing demands for the comforts and conveniences supplied by electrically-operated options and accessories. This opens up greater opportunities, for the forward-looking technician.

The Purpose of this Booklet . . .

. . . is to acquaint you with the systems by which electrical circuits are traced on vehicles. Specifically, it is designed to help you acquire the ability to make your own power checks, quickly and accurately.

Scope of the Booklet

Basically, this is a printed version of the film, "How to Read a Wiring Diagram." It is in no sense a manual of the shop methods by which electrical repairs are made.

It *can* be a helpful guide that can introduce you to the principles of wiring diagrams and vehicle wiring. As you gain experience in reading wiring diagrams, you'll accumulate your own know-how in this important skill. When it becomes "second nature" to you, these pages will have served their purpose — and yours.



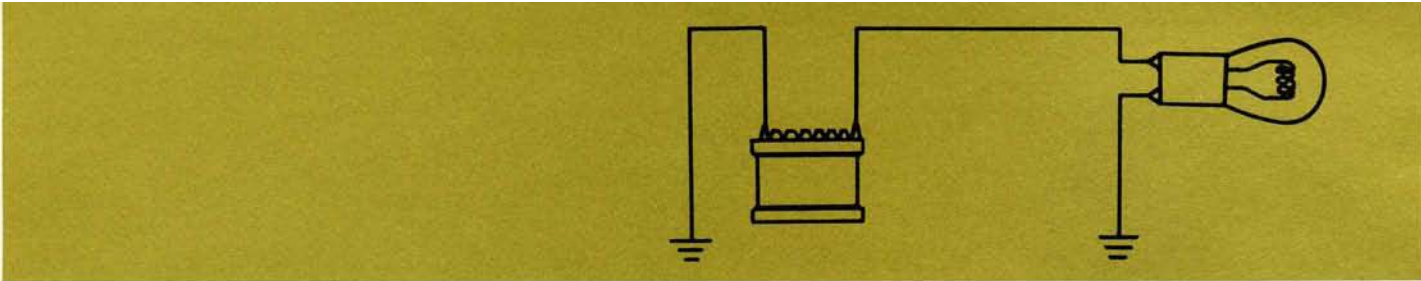

To show how to read wiring diagrams — and to explain how they can be used to help you troubleshoot problems in the electrical system — is what this booklet is all about. Obviously, these are important subjects.

A LOGICAL APPROACH TO ELECTRICAL DIAGNOSIS



If a customer comes in because his headlights aren't working, you can't just make a snap decision. That's not the *professional way*.



When you go to a doctor, for example, he tries to find out what's *really* wrong with you. He looks beyond the aches and pains you feel, to see what's *causing* the trouble. We call this, *diagnosis*.

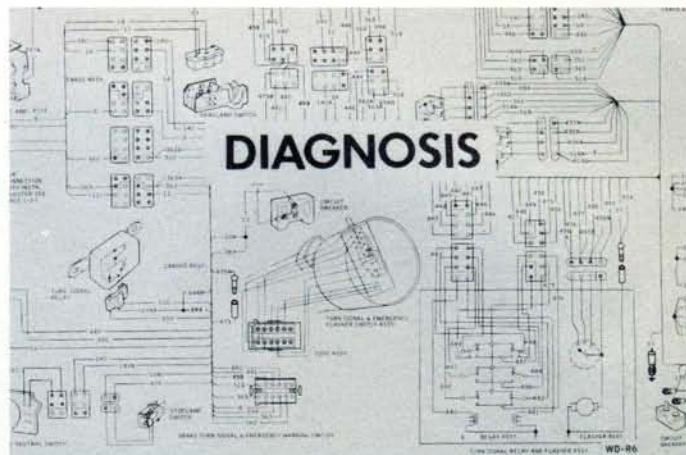

Troubleshooting an electrical system calls for diagnosis, too — *Your* diagnosis. *You're* the doctor. You must find out what's causing the trouble, and fix it.



BUY IT NOW!

Click Here To Order

unit may be the way may not. Snap professional.



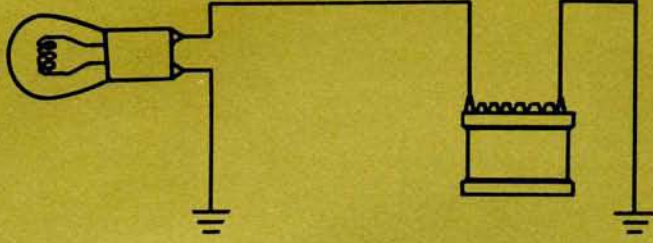

LOGICAL APPROACH

The easiest way is to begin with a *logical approach* — you check things out. You find out what parts of the electrical system are still working okay. You narrow it down to one part — one wire — one switch.

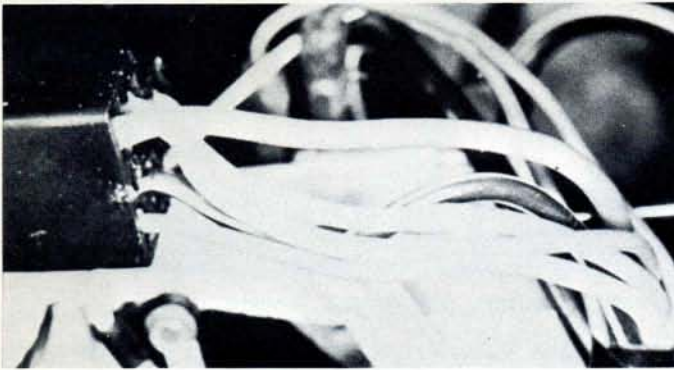

Sure, you may feel a little confused when you face a jumble of wires for the first time. But there's a way to make sense out of this. There *is* a logical approach.

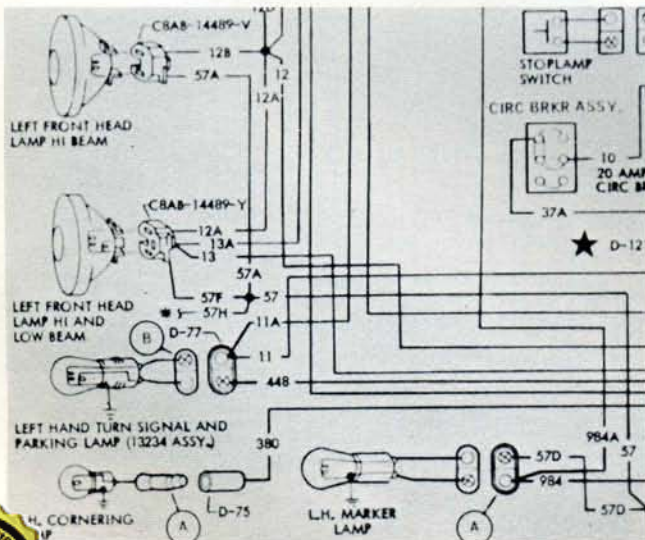

LIKE READING A ROAD MAP

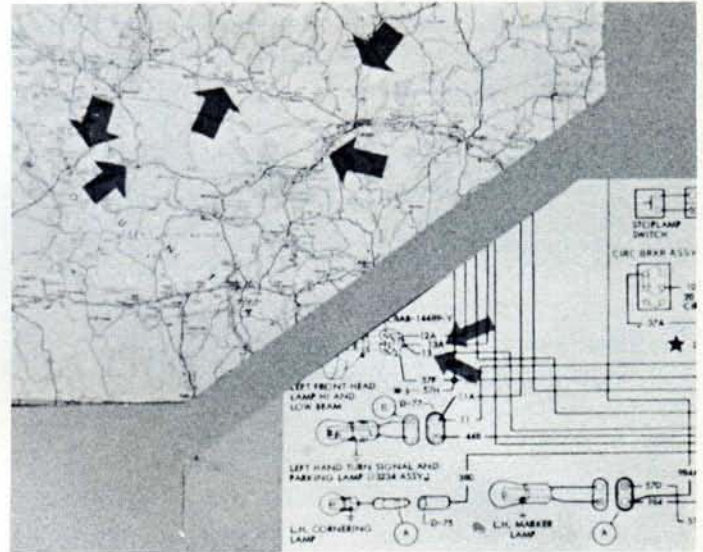

Reading a wiring diagram is something like reading a road map. The map shows routes that connect one place with another . . . and a diagram shows routes, too. The lines represent actual wires, and these wires are identified by numbers . . . much like highways are identified by number.

HOW WIRES ARE NUMBERED AND COLOR-CODED



When you want to locate a specific highway, you check the number on the map with a number on a highway sign. It's almost that easy with wires and wiring numbers.



BUY IT NOW!

Click Here To Order

hat shows all elec-
trophics, connections,
eed to know.

PayPal

Discover
Cards

DISCOVER
WORLDWIDE

MasterCard

VISA