

# Colorized

# Mustang Wiring & Vacuum Diagrams

*(with Electrical Illustrations)*

**Free Bonus!**  
30-Minute Video  
Ford Training  
Course 13001, Vol 68 S7  
"How to Read Wiring  
Diagrams"  
Included!

A consolidated collection of original Ford electrical & vacuum diagrams with illustrations

## Color diagrams for:

- Convenience System; Exterior Lights; Interior Lights;
- Heater and Air Conditioner
- Horns; Convertible Top
- Ignition, Starting and Charging
- Heated Backlite, Cigar Lighter, Clock, Power Windows;
- Radio AM, FM and Stereo
- Tape; Windshield Wiper and Washer; Intermittent Wipers;
- Key Warning Buzzer; Mustang Emission Control

and much more!!



**BUY IT NOW!**

[Click Here To Order](#)

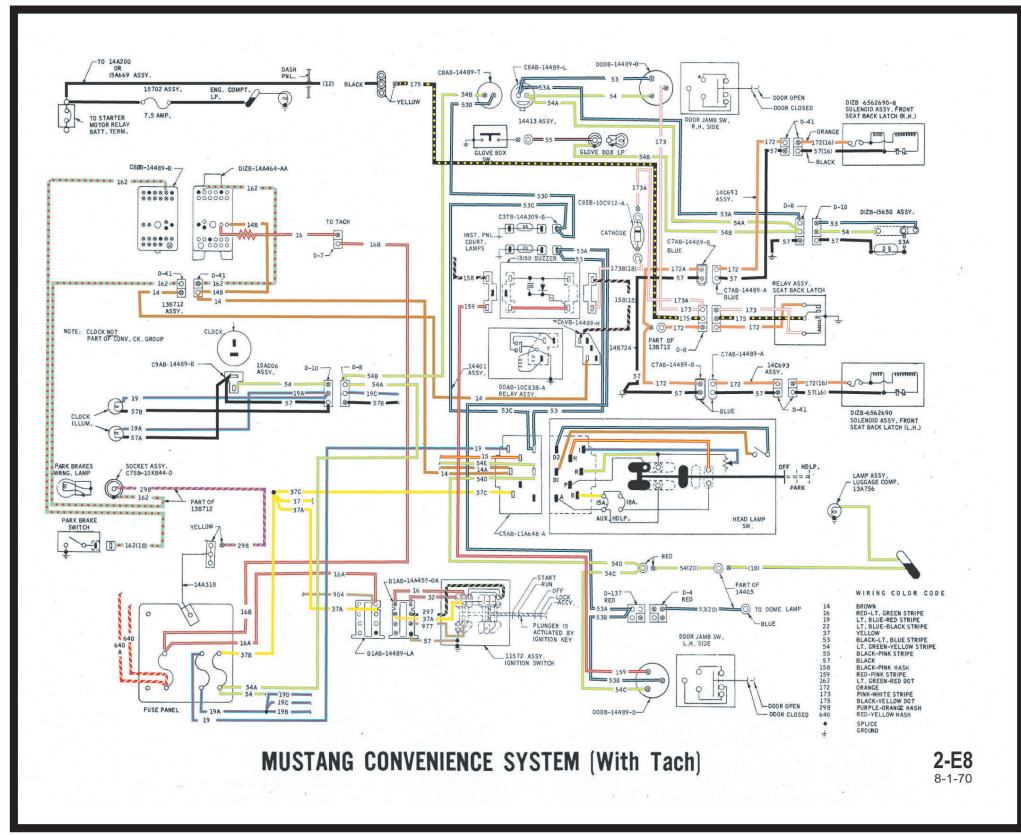

MUSTANG CONVENIENCE SYSTEM (With Tach)

2-E8  
8-1-70

Example of colorized diagrams

Copyright © 2008, Forel Publishing Company, LLC, Woodbridge, Virginia

All Rights Reserved. No part of this book may be used or reproduced in any manner whatsoever without written permission of Forel Publishing Company, LLC. For information write to Forel Publishing Company, LLC, 3999 Peregrine Ridge Ct., Woodbridge, VA 22192

1971 Colorized Mustang Wiring and Vacuum Diagrams  
(Extracted from Form FD-7795P-71, Form 7098-71-3, FP-7635B, and FD-7943-G)  
EAN: 978-1-60371-030-5  
ISBN: 1-60371-030-2

**Forel Publishing Company, LLC**  
**3999 Peregrine Ridge Ct.**  
**Woodbridge, VA 22192**  
**Email address: [webmaster@ForelPublishing.com](mailto:webmaster@ForelPublishing.com)**  
**Website: <http://www.ForelPublishing.com>**

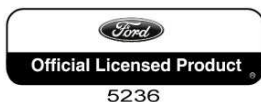

This publication contains material that is reproduced and distributed under a license from Ford Motor Company. No further reproduction or distribution of the Ford Motor Company material is allowed without the express written permission of Ford Motor Company.

---

## Note from the Editor

This product was compiled using several original Ford Motor Company publications. In some cases, there are slight differences between publications, so it is important to compare between diagrams, schematics, or illustrations. The contents of this product were extracted from: *1971 Wiring and Vacuum Diagrams* (Form FD-7795P-71), *1965/1972 Ford Car Master Parts and Accessory Catalog* (Form FP-7635B), *1971 Car Shop Manual* (Volume III, FORM 7098-71-3), and *How to Read Wiring Diagrams* (FD-7943-G, January 1968).

---

## Disclaimer

Although every effort was made to ensure the accuracy of this book, no representations or warranties of any kind are made concerning the accuracy, completeness or suitability of the information, either expressed or implied. As a result, the information contained within this book should be used as general information only. The author and Forel Publishing Company, LLC shall have neither liability nor responsibility to any person or entity with respect to any loss or damage caused, or alleged to be caused, directly or indirectly by the information contained in this book. Further, the publisher and author are not engaged in rendering legal or other professional services. If legal, mechanical, electrical, or other expert assistance is required, the services of a competent professional should be sought.





## ATTENTION

### Please Read This



It is important to note that there may be errors in the diagrams, even though they are original Ford publications. Below are two examples of possible errors because the color code on the page diagram does not match the master Car Standard Wire Code Chart. If your vehicle has a color coded wire that does not match a diagram you should consult the other diagrams contained in the manual for a possible match.

#### *Example of possible errors*

37	YELLOW
38	BLACK
54	LT. GREEN-YELLOW STRIPE
158	BLACK-PINK HASH STRIPE

In the wiring diagrams from the Ford publication Form 7795P-71, the Key Warning Buzzer Wiring Color Code shows:

**38 Black**

However, the Car Standard Wire Color Code Chart lists:

**38 – Black-Orange Stripe**

37	YELLOW
38	BLACK
54	LT. GREEN-YELLOW STRIPE
158	BLACK-PINK HASH STRIPE

In the wiring diagrams from the Ford publication Form 7795P-71, the Key Warning Buzzer Wiring Color Code shows:

**158 Black-Pink HASH STRIPE**

However, the Car Standard Wire Color Code Chart lists:

**158 – Black- Pink HASH**

The color coded wiring diagrams are provided for illustration purposes only. Only the wire number should be used for the identification of the wire itself. The color coding of the wires in the product may not match the actual colors of the wires in the vehicle. In some cases, the colors have been altered to provide a visual contrast (i.e. the color white has been shaded to make it more visible). As stated in the paragraph above, there are some variation and/or differences between the original Ford wiring diagrams. If your vehicle has a color coded wire that does not match a diagram you should consult the other diagrams contained in the manual for a possible match.

**Disclaimer:** Although every effort was made to ensure the accuracy of this book, no representations or warranties of any kind are made concerning the accuracy, completeness or suitability of the information, either expressed or implied. As a result, the information contained within this book should be used as general information only. The author and Forel Publishing Company, LLC shall have neither liability nor responsibility to any person or entity with respect to any loss or damage caused, or alleged to be caused, directly or indirectly by the information contained in this book. Further, the publisher and author are not engaged in rendering legal or other professional services. If legal, mechanical, electrical, or other expert assistance is required, the services of a competent professional should be sought.

**100% SATISFACTION GUARANTEED**

**BUY IT NOW!**

**Click Here To Order**

Source Document  
Ford Publication Form 7795P-71

# 1971

COURSE 13003 and 1703

# WIRING and VACUUM DIAGRAMS



**SERVICE  
TRAINING**

FORM 77

**BUY IT NOW!**  
**Click Here To Order**

100% SATISFACTION GUARANTEE

PayPal  
MasterCard  
Discover  
VISA

A vertical promotional banner with a red and yellow background. It features a large white arrow pointing upwards. The text "BUY IT NOW!" and "Click Here To Order" is written in bold white letters. Below this is a circular seal with "100% SATISFACTION GUARANTEE" around the perimeter. At the bottom, there are logos for PayPal, MasterCard, Discover, and VISA.

# FOREWORD

This book contains wiring and vacuum diagrams for all Ford and Lincoln-Mercury car lines and all Ford trucks.

Both wiring and vacuum diagram replacement sheets will be released as required to keep the book current.

All vacuum systems are contained in a separate section.

This book is divided by vehicles. Refer to the applicable section as follows:

- Pinto
- Maverick and Comet
- Mustang and Cougar
- Torino
- Montego
- Ford and Meteor
- Mercury
- Thunderbird
- Mark III
- Lincoln
- Bronco, Econoline and P-Series
- B and F-100-750 Series
- C and CT-Series
- W-Series
- L-Series



The illustrations contained in this book were in effect at the time the book was approved for printing. Ford Motor Companies, whose policy is one of continuous improvement, reserves the right to discontinue models at any time, or to change specifications or design, without notice and without incurring obligation.

A promotional banner with a yellow and red background. On the left is a circular seal that says "SATISFACTION 100% GUARANTEED". In the center, the text "BUY IT NOW!" is written in large, bold, black letters. Below that, "Click Here To Order" is written in a smaller font, with a red arrow pointing to the right. At the bottom of the banner are logos for PayPal, American Express, Discover, MasterCard, and VISA.

# HOW TO USE THE WIRING DIAGRAMS

Two styles of wiring diagrams are contained in this book.

I – Cars (Except Mustang, Cougar and Lincoln) and L-Series Truck.

II – Mustang, Cougar, Lincoln and Truck (Except L-Series)

## I – CARS (Except Mustang, Cougar and Lincoln) AND L-SERIES TRUCKS

Each electrical circuit is illustrated in a clear and easy to follow style.

There are 7 steps that should be followed to use this diagram to diagnose electrical problems.

- Verify the complaint
- Refer to the Index
- Locate inoperative system
- Identify other systems on the circuit
- Isolate the problem area
- Correct the problem
- Operate the corrected system

### VERIFY THE COMPLAINT

To diagnose a customer complaint “Back Up Lights Don’t Work” the first thing we should do is verify the complaint.

If both lights do not work, refer to the INDEX on page 1 of the vehicle schematic.

See LAMPS – BACK-UP on the INDEX. The INDEX lists the location of the part on the drawing.

The drawing is set up like a road map. For example: the Pinto Back-up lights are located at B-27. To locate B-27 on the schematic, find the number 27 at the top of the illustration.

Now, find the letter B on the side of the illustration. Follow the number and the letter until they intersect. The part will be within an inch or two of the intersection.

### LOCATE INOPERATIVE SYSTEM

Generally, the power supply for all components on this drawing comes from the top of the page and over to the battery at the left.

The ground for each component is always toward the bottom of the drawing.

There are symbols used on this drawing that are explained as follows:

- Ground symbols are shown in Figure 1. A ground wire connected away from the component is identified by a code G1 or G2, etc. The location of the remote ground is listed in the GROUND CODES chart and the bottom of the page.

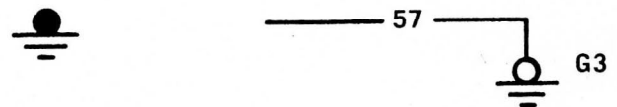

Fig. 1 — Ground Symbols

- Wire color code is shown in Fig. 2. Wiring Color Codes are listed at the bottom of the drawing. New Standard Wiring Color Codes are listed behind these instructions.



Fig. 2 — Wire Color Code

100% SATISFACTION GUARANTEED

BUY IT NOW!

Click Here To Order

PayPal American Express Discover Novus MasterCard VISA

1 to locate the

## CORRECT THE PROBLEM

Use standard continuity tests for open circuits and short circuit tests to find the specific problem.

Repair or replace the electrical component that is malfunctioning.

## OPERATE CORRECTED SYSTEM

It is a good practice to operate the system after a repair has been made to see if it now works.

## BULB AND FUSE CHART

A bulb and fuse chart is included on the first page of this schematic for your convenience.

# II – MUSTANG, COUGAR, LINCOLN AND TRUCKS (Except L-Series)

The index page is the first page in each section. Each electrical schematic will have a notation as to the source of power for that system. All wires will be shown as single lines to provide a clear understanding of the diagrams. To trace a circuit, it is recommended to start at the ground circuit of the inoperative component, trace it through all connectors to the source, and note the possible trouble areas and points of most convenient access. Wire connectors will be identified on the schematic and the pictorial drawings, this will show the technician the location of the connectors. Most wire connectors are shown in open book fashion. A wire on the top right of a connector (open side by side) will be on the top left side of the other half of the connector. See Figure 9 (Wire No. 140 to No. 140A, etc.)

Wire disconnects and connectors will all be black unless a color code is noted on the diagram. The colored disconnects and connectors are to aid the technician in finding the proper circuit to be tested or traced. Pictorial drawings of a component will include specific location of some components in cases where the component is located in the engine

Relays and switches are shown in the "System Off" position. If a vehicle specific wire color in a connector does not match the diagram shown, it can usually be identified by comparing the other colors shown at the wire connectors. Specific wire color deviations in the manufacturing of a wire harness are usually for a short duration.

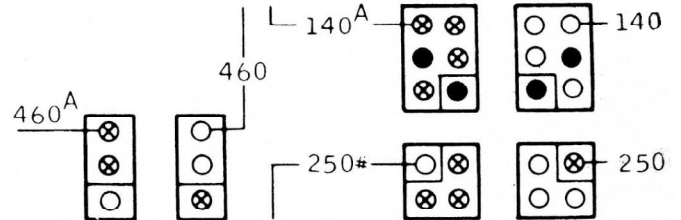

Fig. 9 – Connectors

**100% SATISFACTION GUARANTEED**

**BUY IT NOW!**

**Click Here To Order**

PayPal   American Express   Discover   MasterCard   VISA

# CAR STANDARD WIRE COLOR CODE CHART

## (1 OF 3)

CIRCUITS IN CURRENT USE  
\*\*\*\*\*

CIRCUIT	DESCRIPTION	COLOR NO.	BASE	STRIPE	WISH	DUT	CIRCUIT
1	HORN SWITCH CONTROL	69	DK BLUE				1*
2	RH FRONT TURN SIGNAL LAMP	59	WHITE	LT BLUE			2
3	LH FRONT TURN SIGNAL LAMP	39	LT GREEN	WHITE			3
4	ALTERNATOR REG. "S" TERM. TO ALTERNATOR "S" TERM	51	WHITE	BLACK			4
5	RH REAR TURN SIGNAL LAMP	29	ORANGE	LT BLUE			5
6	HORN RELAY TO HORN	139	YELLOW		LT GREEN		6
7	SEAT SWITCH ARM TERM TO RELAY FIELD TERM	232	LT GREEN			YELLOW	7
8	TURN SIGNAL FLASHER FEED	23	ORANGE	YELLOW			8
9	LH REAR TURN SIGNAL LAMP	36	LT GREEN	ORANGE			9
10	STOP LAMP SWITCH FEED	147	LT GREEN		RED		10
12	HEADLAMP DIMMER SWITCH TO HIGH BEAMS	34	LT GREEN	BLACK			12
13	HEADLAMP DIMMER SWITCH TO LOW BEAMS	14	RED	BLACK			13
14	HEADLAMP SWITCH TO TAIL LAMPS AND SIDE MARKER LAMPS	7	BROWN				14*
15	HEADLAMP SWITCH TO HEADLAMP DIMMER SWITCH	16	RED	YELLOW			15
16	IGNITION SWITCH TO IGNITION COIL "BATT." TERMINAL	17	RED	LT GREEN			16
17	LOW OIL PRESSURE WARNING LAMP TO LOW OIL PRESS. SENDING UNIT	59	WHITE				17
18	SEAT SWITCH TO RELAY FIELD TERM	215	ORANGE			YELLOW	18
19	INSTRUMENT PANEL LAMPS FEED	42	LT BLUE	RED			19
22	BRAKE FEED	41	LT BLUE	BLACK			22
28	WINDSHIELD WIPER SW. TO WINDSHIELD WIPER MOTOR	181	BLACK			PINK	28
29	FUEL GAGE TO FUEL GAGE SENDER	32	YELLOW	WHITE			29
30	CONSTANT VOLTAGE UNIT AND INDICATOR LAMPS FEED	4	BLACK	LT GREEN			30
31	OIL PRESSURE INDICATOR TO OIL PRESSURE SENDING UNIT	52	WHITE	RED			31
32	STARTER CONTROL	18	RED	LT BLUE			32
39	ALTERNATOR REGULATOR "F" TERM. TO ALTERNATOR	25	ORANGE	LT BLUE			39
36	ALTERNATOR OUTPUT	223	YELLOW			WHITE	36
37	BATTERY TO LOAD	27	YELLOW				37*
38	POWER SUPPLY TO BATTERY	2	BLACK	ORANGE			38
39	TEMP. GAGE TO TEMP. SENDING UNIT	19	RED	WHITE			39
40	CIGAR LIGHTER FEED	45	LT BLUE	WHITE			40
41	WARNING LAMP FEED	109	BLACK	WHITE	LT BLUE		41
42	SWITCH TO WARNING LAMP	206	RED			WHITE	42
43	LOW AIR BUZZER FEED	134	ORANGE		LT BLUE		43
44	TURN SIGNAL FLASHER TO TURN SIGNAL SWITCH	40	LT BLUE				44
45	HOT WATER TEMP. RELAY TO HOT WATER TEMP. SENDING UNIT	29	YELLOW	RED			45
48	BLIND CIRCUIT TERM IN HARNESS CANNOT BE CHECKED FOR CONT (COLOR OPT)	264					48*
51	SEAT REG. CONTROL SWITCH FEED	186	BLACK			WHITE	51
53	COURTESY LAMP SWITCH TO COURTESY LAMP	5	BLACK	LT BLUE			53
54	INTERIOR LAMP SWITCH FEED	37	LT GREEN	YELLOW			54
55	CARGO LAMP SW. TO CARGO LAMP	61	BLACK	PINK			55
56	WINDSHIELD WIPER SW. TO WINDSHIELD WIPER MOTOR	70	DK BLUE	ORANGE			56
57	GROUND CIRCUIT	1	BLACK				57*
58	WINDSHIELD WIPER SW. TO WINDSHIELD WIPER MOTOR	50	WHITE				58
60	CONSTANT VOLTAGE UNIT TO GAGE	184	BLACK		LT GREEN		60
61	WINDSHIELD WIPER SW. TO WINDSHIELD WIPER MOTOR	29	YELLOW	RED			61
63	WINDSHIELD WIPER SW. TO WINDSHIELD WIPER MOTOR	13	RED				63
64	WINDSHIELD WIPER SW. TO WINDSHIELD WIPER MOTOR	64	DK GREEN				64
66	AIR SHIFT SWITCH TO INDICATOR LAMP	40	LT BLUE				66
64	COIL TERM. IGN. SW. TO FUEL SOLENOID	118	RED		PINK		69
73	LOW AIR BUZZER TO LOW AIR BUZZER SWITCH	133	ORANGE		LT GREEN		73
74	RELAY "B" TERMINAL TO LAMP (WATER)	33	LT GREEN				74
75	STARTING MOTOR RELAY TO SERIES PARALLEL SW. (#1 TERM)	150	LT GREEN		PURPLE		75
80	ENGINE COMPARTMENT LAMP FEED	182	BLACK			ORANGE	80
84	LECK LID SOLENOID FEED	163	PURPLE		YELLOW		84
88	INSTRUMENT PANEL LAMP SWITCH FEED	6	BLACK	WHITE			88

89	GLOW PLUG TO GLOW PLUG SWITCH	24	ORANGE	LT GREEN			89
102	OVERDRIVE KICKDOWN SWITCH TO OVERDRIVE GOVERNOR	50	WHITE				102
103	OVERDRIVE KICKDOWN SW. TO IGN. COIL	297	WHITE			RED	103
104	OVERDRIVE KICKDOWN SW. TO OVERDRIVE SOLENOID	43	LT BLUE	ORANGE			104
105	OVERDRIVE KICKDOWN SWITCH TO OVERDRIVE RELAY	203	RED			YELLOW	105
106	OVERDRIVE SOLENOID TO OVERDRIVE RELAY	40	LT BLUE				106
111	WARNING LAMP TO LIGHTS ON RELAY	3	BLACK	YELLOW			111
112	WARNING LAMP RELAY FEED	18	BLACK			YELLOW	112
113	STARTING MOTOR TO STARTING MOTOR RELAY	222	YELLOW			LT BLUE	113
114	FEED TO VACUUM DOOR LOCK SWITCH	113	TAN		YELLOW		114
117	VACUUM DOOR LOCK SWITCH TO SOLENOID (LOCK)	33	LT GREEN				115
116	VACUUM DOOR LOCK SWITCH TO SOLENOID (UNLOCK)	188	BROWN			ORANGE	116
117	DOOR LOCK MOTOR (LOCK)	207	PINK			BLACK	117
118	DOOR LOCK MOTOR (UNLOCK)	208	PINK			ORANGE	118
119	DOOR LOCK SWITCH (LOCK)	209	PINK			YELLOW	119
120	DOOR LOCK SWITCH (UNLOCK)	210	PINK			LT GREEN	120
122	TOP CONTROL SWITCH TO TOP CONT. MOTOR OR RELAY	27	YELLOW				122
123	TOP CONTROL SWITCH TO TOP CONT. MOTOR OR RELAY	13	RED				123
129	MAP LAMP SWITCH TO RH MAP LAMP	9	BROWN	YELLOW			125
126	COURTESY LAMP SW. TO INSTR. PANEL COURTESY LAMP	182	BLACK			ORANGE	126
127	COURTESY LAMP SW. TO "C" PILLAR LAMPS	185	BLACK			LT BLUE	127
129	GLOW PLUG SWITCH FEED	33	LT GREEN				129
131	CIGAR LIGHTER LAMP FEED	60	PURPLE	ORANGE			131
133	RELAY TO MAP LAMP SWITCH	111	TAN		RED		133
137	RADIO # ANTENNA SWITCH FEED	136	YELLOW		BLACK		137
138	DOOR JAMB SWITCH TO LIGHTS ON RELAY	11	BROWN	LT BLUE			138
140	BACK UP LAMP	61	BLACK	PINK			140
141	TWO OR THREE SPEED AXLE SWITCH TO TWO OR THREE SPEED AXLE MOTOR	181	BLACK			PINK	141
142	TWO OR THREE SPEED AXLE SWITCH FEED	142	DK GREEN		YELLOW		142
143	TWO OR THREE SPEED AXLE SWITCH TO TWO OR THREE SPEED AXLE MOTOR	13	RED				143
151	SPEED CONTROL ON-OFF SWITCH TO AMPLIFIER	156	LT BLUE		BLACK		151
153	STARTING MOTOR RELAY TO FLASHER	19	RED	WHITE			151
158	KEY WARNING SWITCH TO BUZZER	98	BLACK		PINK		153
159	DOOR JAMB SWITCH TO BUZZER	63	RED		PINK		158
160	BUZZER TO WARNING INDICATOR RELAY	88	WHITE	PINK			159
162	EMERG. BRAKE WARNING LAMP TO EMERG. BRAKE SWITCH	230	LT GREEN			RED	160
170	WINDOW REGULATOR SWITCH FEED	205	RED			LT BLUE	162
171	CIRCUIT BREAKER TO SEAT LATCH RELAY	4	BLACK	WHITE			170
172	RELAY TO SEAT LATCH SOLENOID	20	ORANGE				171
173	DOOR SWITCH TO SEAT LATCH RELAY (COIL TERM.)	85	PINK	WHITE			172
175	TOP CONTROL SWITCH OR RELAY FEED	183	BLACK			YELLOW	173
176	REAR WINDOW REGULATOR SWITCH FEED	50	WHITE				175
177	HORIZONTAL SEAT REG. MOTOR TO RELAY	27	YELLOW				176
180	HORIZONTAL SEAT REG. MOTOR TO RELAY	13	RED				177
181	FLOOR MOTOR FEED	8	BROWN	ORANGE			180
182	FLOOR MOTOR FEED	112	BROWN	WHITE			181
183	FLOOR MOTOR FEED	108	BROWN		ORANGE		182
184	FLOOR MOTOR FEED	1	BLACK	LT BLUE			183
186	FLOOR MOTOR FEED	71	DK BLUE	YELLOW			184
188	FLOOR MOTOR FEED	138	YELLOW		LT GREEN		186
189	FLOOR MOTOR FEED	79	PINK				188
194	FLOOR MOTOR FEED	194	TAN			RED	189
195	FLOOR MOTOR FEED	195	TAN			ORANGE	194
196	FLOOR MOTOR FEED	196	TAN			YELLOW	195
197	FLOOR MOTOR FEED	197	TAN			LT GREEN	196
198	FLOOR MOTOR FEED	198	TAN			LT BLUE	197
200	FLOOR MOTOR FEED	50	WHITE				198
206*	FLOOR MOTOR FEED	1	BLACK				200
207*	FLOOR MOTOR FEED	69	DK BLUE				206*
212*	FLOOR MOTOR FEED						207*



**BUY IT NOW!**

Click Here To Order



# CAR STANDARD WIRE COLOR CODE CHART

## (2 OF 3)

CIRCUITS IN CURRENT USE  
\*\*\*\*\*

CIRCUIT

CIRCUIT	COLOR NO.	BASE	STRIPE	HASH	DUT	CIRCUIT
213	219	YELLOW				215
226	13	RED			BLACK	226
227	27	YELLOW				227
241	44	LT BLUE	YELLOW			241
243	149	LT GREEN		ORANGE		243
244	140	YELLOW		WHITE		244
245	10	BROWN	LT GREEN			245
246	46	PURPLE				246
247	89	WHITE	YELLOW			247
248	139	YELLOW		LT BLUE		248
249	57	DK BLUE	LT GREEN			249
250	20	ORANGE				250
253	13	RED				253
254	1	BLACK				254
255	157	LT BLUE		RED		255
259	119	RED		ORANGE		259
261	21	ORANGE	BLACK			261
262	62	BROWN	PINK			262
269	159	LT BLUE		ORANGE		269
282	64	DK GREEN				282
283	28	YELLOW	BLACK			283
284	13	RED			WHITE	284
287	103	BLACK		PLRPLE		287
290	56	WHITE			LT GREEN	290
297	101	BLACK			ORANGE	297
298	162	PURPLE				298
306	40	LT BLUE				306
307	50	WHITE				307
313	28	YELLOW	BLACK			313
314	14	RED	BLACK			314
316	31	YELLOW	LT BLUE			316
317	122	RED			LT BLUE	317
319	136	YELLOW			BLACK	319
320	117	RED			BLACK	320
328	203	RED			YELLOW	328
329	29	YELLOW	RED			329
333	16	BLACK	YELLOW			333
334	150	LT GREEN			YELLOW	334
347	4	BLACK	LT GREEN			347
348	157	LT BLUE			PURPLE	348
364	117	RED				364
365	228	DK GREEN			RED	365
366	109	BROWN			BLACK	366
367	129	PINK			WHITE	367
369	221	YELLOW			ORANGE	369
371	109	BROWN			WHITE	371
372	4	PURPLE	YELLOW		LT GREEN	372
379	26	ORANGE				379
380	123	RED	WHITE			380
381	174	WHITE			WHITE	381
383	33	LT GREEN			RED	383
385	9	BROWN	YELLOW			385
387	289	LT BLUE			BLACK	387
389	73	GRAY	BLACK			389
401	74	GRAY	RED			401
402	78	GRAY	WHITE			402
403	86	PURPLE	LT GREEN			403
404	87	PURPLE	LT BLUE			404
405	99	TAN				405
406						406

407	91	TAN	BLACK			407
408	92	TAN	RED			408
409	193	TAN			BLACK	409
442	36	LT GREEN	ORANGE			442
443	35	RED				443
444	34	LT GREEN	BLACK			444
445	25	ORANGE	LT BLUE			445
446	26	ORANGE	WHITE			446
447	22	ORANGE	RED			447
450	67	DK GREEN	LT GREEN			450
454	17	RED	LT GREEN			454
455	140	LT GREEN		YELLOW		455
458	130	ORANGE		BLACK		458
459	24	ORANGE	LT GREEN			459
460	222	YELLOW			LT BLUE	460
469	33	LT GREEN				469
474	96	PINK				474
475	145	DK GREEN	BLACK			475
478	93	TAN		WHITE		478
485	104	BROWN	ORANGE			485
486	192	BROWN		PINK		486
487	81	PINK	ORANGE			487
494	114	TAN		LT GREEN		494
500	46	PURPLE				500
502	49	GRAY				502
503	40	LT BLUE				503
504	155	DK BLUE		WHITE		504
505	1	BLACK				505
507	27	YELLOW				507
508	50	WHITE				508
509	50	TAN				509
511	33	LT GREEN				511
512	22	ORANGE				512
517	6	BLACK	RED			517
519	50	WHITE	WHITE			519
520	166	PURPLE		WHITE		520
526	6	BLACK				526
527	13	RED				527
536	184	BLACK			LT GREEN	536
568	35	LT GREEN				568
587	103	BLACK				587
589	20	ORANGE		WHITE		589
590	72	DK BLUE				590
591	2	BLACK	WHITE			591
592	2	ORANGE				592
593	161	LT BLUE		WHITE		593
596	27	YELLOW				596
597	182	BLACK			ORANGE	597
598	13	RED				598
601	82	PINK	YELLOW			601
602	58	LT BLUE	PINK			602
604	121	RED		LT GREEN		604
606	131	ORANGE		RED		606
626	126	PINK		YELLOW		626
627	99	BLACK		ORANGE		627
632	1	BLACK				632
633	13	RED				633
634	40	LT BLUE				634
635	34	LT GREEN				635
640	120	RED		YELLOW		640
642	54	WHITE	LT GREEN			642

**100% SATISFACTION GUARANTEED**

**BUY IT NOW!**

**Click Here To Order**

PayPal, American Express, Discover, MasterCard, VISA

# CAR STANDARD WIRE COLOR CODE CHART

## (3 OF 3)

CIRCUITS IN CURRENT USE  
\*\*\*\*\*

CIRCUIT	COLOR NO.	BASE	STRIPE	WASH	DUT	CIRCUIT
647	200	RED			BLACK	647
648	205	RED			LT BLUE	648
654	30	YELLOW	LT GREEN			654
655	15	RED	ORANGE			655
660	221	YELLOW			LT GREEN	660
671	50	WHITE				671
672	109	BROWN		WHITE		672
673	35	LT GREEN				673
674	32	BROWN	WHITE			674
675	35	LT GREEN	RED			675
683	187	BROWN			PINK	683
684	6	BLACK	WHITE			684
686	75	GRAY	ORANGE			686
687	76	GRAY	YELLOW			687
688	77	GRAY	LT BLUE			688
697	21	ORANGE	BLACK			697
745	113	RED		PINK		745
746	66	DK GREEN	YELLOW			746
751	155	DK BLUE		WHITE		751
752	220	YELLOW			RED	752
753	29	YELLOW	RED			753
754	191	LT GREEN		WHITE		754
755	12	BROWN	WHITE			755
756	201	RED			PINK	756
757	19	RED	WHITE			757
758	240	PURPLE			WHITE	758
761	54	WHITE	LT GREEN			761
765	149	LT GREEN		YELLOW		765
766	204	RED			LT GREEN	766
767	43	LT BLUE	ORANGE			767
768	149	LT GREEN		YELLOW		768
769	160	LT BLUE		YELLOW		769
773	141	DK GREEN		ORANGE		773
775	89	WHITE				775
776	213	ORANGE	PINK			776
780	13	RED				780
787	124	PINK		BLACK		787
788	202	RED			ORANGE	788
790	53	WHITE	ORANGE			790
797	38	LT GREEN	PURPLE			797
804	133	ORANGE			LT GREEN	804
805	178	WHITE			LT GREEN	805
806	84	PINK	LT BLUE			806
807	33	PINK	LT GREEN			807
808	8	BROWN	ORANGE			808
810	121	RED			LT GREEN	810
817	115	TAN			LT BLUE	817
818	116	TAN			WHITE	818
822	184	BLACK			LT GREEN	822
823	33	LT GREEN				823
848	202	RED			ORANGE	848
850	244	LT BLUE			WHITE	850
851	33	LT GREEN				851
852	154	LT BLUE			PINK	852
853	119	RED			ORANGE	853
854	106	BROWN			YELLOW	854
858	125	PINK			ORANGE	858
859	27	YELLOW				859
860	48	PURPLE				860
861	45	LT BLUE	WHITE			861
863	3	BLACK	YELLOW			863
869	37	LT GREEN	YELLOW			869
870	13	RED				870
883	129	PINK			LT BLUE	883
904	35	LT GREEN	RED			904
914	69	DK GREEN	ORANGE			914
917	177	WHITE			LT GREEN	917
920	46	PURPLE			YELLOW	920
923	13	RED				923
924	53	WHITE	ORANGE			924
925	97	TAN	WHITE			925
934	110	TAN			BLACK	934
939	6	BLACK	WHITE			939
941	144	DK GREEN			PURPLE	941
943	164	PURPLE			LT GREEN	943
946	51	WHITE				946
950	15	RED	BLACK			950
955	36	LT GREEN	ORANGE			955
959	203	RED				959
960	204	RED			YELLOW	960
962	204	RED			LT GREEN	962
963	143	DK GREEN				963
975	117	RED			BLACK	975
976	184	BLACK			LT GREEN	976
977	48	PURPLE	WHITE			977
978	31	YELLOW	LT BLUE			978
979	19	RED	LT BLUE			979
980	32	YELLOW	WHITE			980
981	19	RED	WHITE			981
982	30	YELLOW	LT GREEN			982
983	17	RED	LT GREEN			983
984	222	YELLOW			LT BLUE	984
985	205	RED			LT BLUE	985
986	225	YELLOW			WHITE	986
987	206	RED			WHITE	987
988	221	YELLOW			LT GREEN	988
989	204	RED			LT GREEN	989
993	12	BROWN	WHITE			993



**BUY IT NOW!**

Click Here To Order



## CIRCUIT SYMBOLS

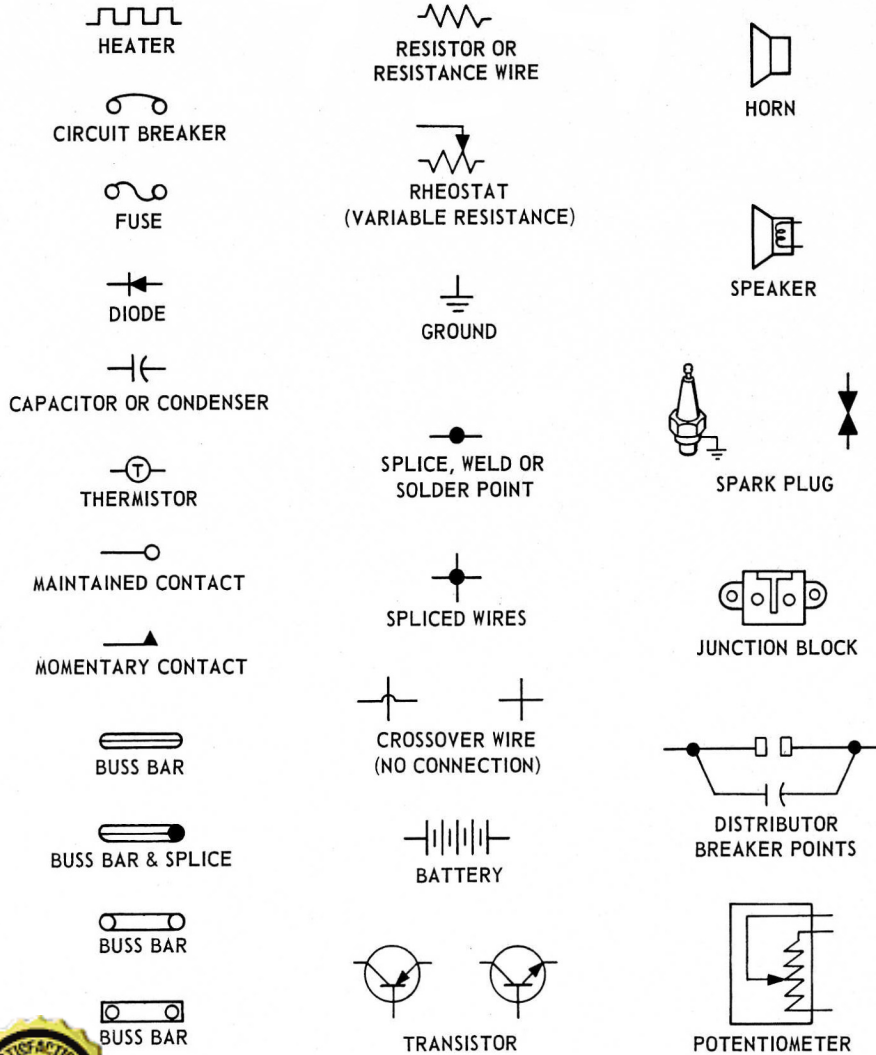

## SWITCHES

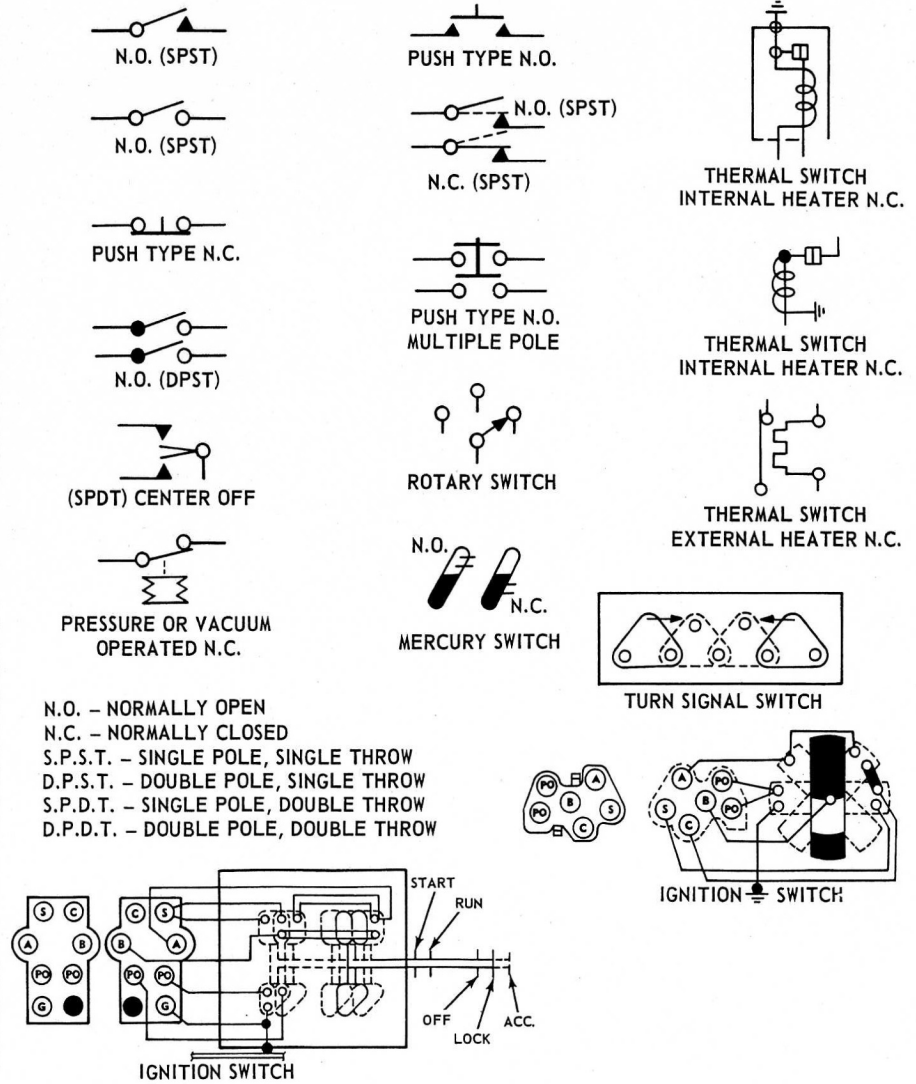

**100% SATISFACTION GUARANTEED**

**BUY IT NOW!**

**Click Here To Order**



## RELAYS

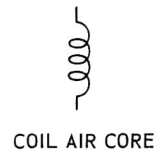
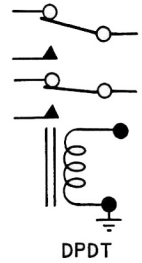
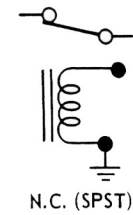
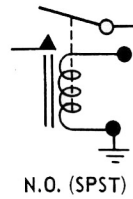
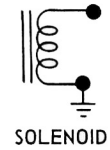
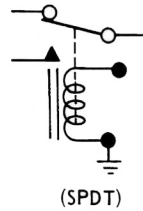
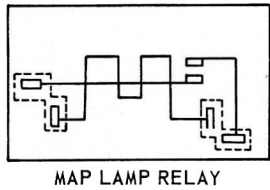
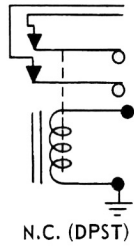
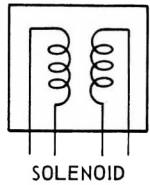
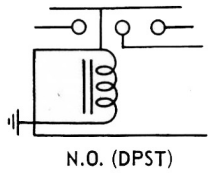

## LAMPS

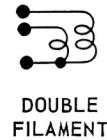
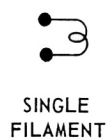

## CONNECTORS

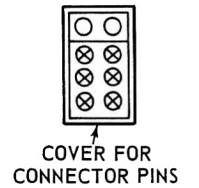
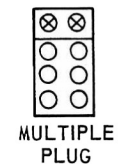
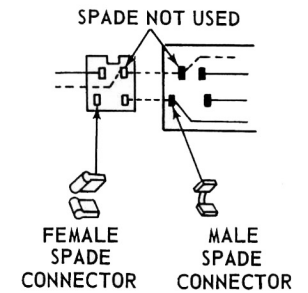
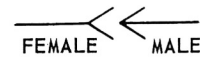
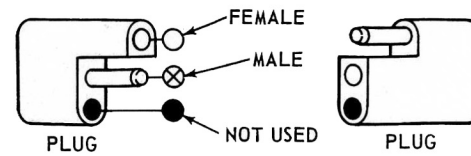

## MOTORS

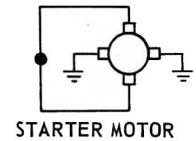
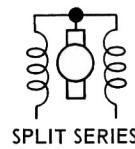
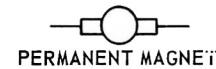

## GAUGES

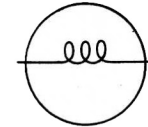
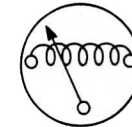
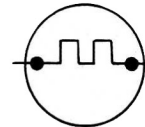

N.O. - NORMALLY OPEN  
N.C. - NORMALLY CLOSED  
S.P.S.T. - SINGLE POLE, SINGLE THROW  
D.P.S.T. - DOUBLE POLE, SINGLE THROW  
S.P.D.T. - SINGLE POLE, DOUBLE THROW  
D.P.D.T. - DOUBLE POLE, DOUBLE THROW

**100% SATISFACTION GUARANTEED**

**BUY IT NOW!**

**Click Here To Order**

# 1971 MUSTANG AND COUGAR ELECTRICAL DRAWINGS

## SECTION 2 INDEX

	PICTORIAL	SCHEMATIC		PICTORIAL	SCHEMATIC		PICTORIAL	SCHEMATIC
<b>AIR CONDITIONER</b>								
Mustang & Cougar	2-E5	2-E28						
<b>CHARGING</b>								
Mustang	2-E2	2-E10 & 11						
Cougar	2-E3	2-E10 & 11						
Cougar XR7	2-E3	2-E12 & 13						
<b>CIGAR LIGHTER</b>								
Mustang	2-E2	2-E22						
Cougar	2-E3	2-E22						
<b>CLOCK</b>								
Mustang	2-E5	2-E22						
Cougar	2-E4	2-E23						
<b>CONVENIENCE SYSTEMS</b>								
Mustang		2-E8						
Cougar		2-E14						
<b>CONVERTIBLE TOP</b>								
Mustang & Cougar	2-E2 & 3	2-E19						
<b>EMISSION CONTROL</b>								
Mustang 6 Cyl. Auto. Trans.		2-E34						
<b>EXTERIOR LIGHTS</b>								
Mustang	2-E2	2-E16 & 17						
Cougar	2-E3	2-E18 & 20						
Mach I		2-E15						
<b>GAUGES</b>								
Mustang	2-E5	2-E11						
Cougar	2-E5	2-E13						
Cougar XR7	2-E5	2-E14						
<b>HEADLAMP "ON" WARNING BUZZER</b>		2-E29						
<b>HEATED BACKLITE</b>								
Mustang		2-E6						
Cougar		2-E33						
<b>HEATER AND DEFROSTER</b>								
Mustang & Cougar	2-E2 & 3	2-E28						
<b>HORNS</b>								
Mustang & Cougar	2-E2 & 3	2-E34						
<b>KEY WARNING BUZZER</b>		2-E30						
<b>IGNITION</b>								
Mustang	2-E2	2-E10 & 11						
Cougar	2-E3	2-E12 & 13						
<b>INTERIOR LIGHTS</b>								
Mustang	2-E2	2-E22						
Cougar	2-E3	2-E23						
Cougar XR7	2-E3	2-E24						
<b>PARKING BRAKE WARNING LIGHT</b>		2-E9 & 13						
<b>POWER SEAT</b>								
Cougar		2-E25						
<b>POWER WINDOWS</b>								
Mustang & Cougar	2-E4	2-E32						
<b>RADIO AND STEREO TAPE</b>								
Mustang & Cougar	2-E4 & 5	2-E31						
<b>SEAT BACK LATCH</b>		2-E7 & 8						
<b>SEAT BELT REMINDER LIGHTS</b>								
Mustang & Cougar	2-E2 & 3	E9 & E13						
<b>STARTING</b>								
Mustang	2-E2	2-E11						
Cougar	2-E3	2-E11						
Cougar XR-7	2-E3	2-E11						
<b>TACHOMETER</b>								
Mustang & Cougar	2-E5	2-E11						
<b>TURN SIGNALS</b>								
Mustang	2-E2	2-E16						
Cougar	2-E3	2-E20						
<b>WINDSHIELD WIPERS AND WASHERS</b>								
Mustang & Cougar	2-E2 & 3	2-E22						
Mustang & Cougar (Intermittent)		2-E22						

**BUY IT NOW!**  
Click Here To Order

100% GUARANTEED SATISFACTION



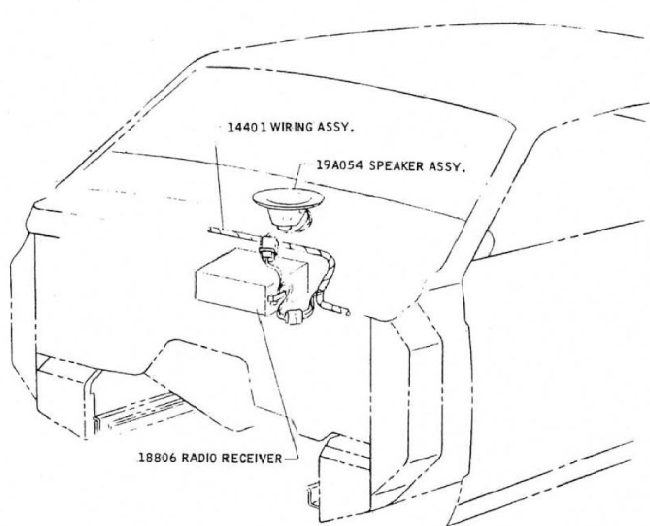

MUSTANG-COUGAR AM RADIO & FRONT SPEAKER

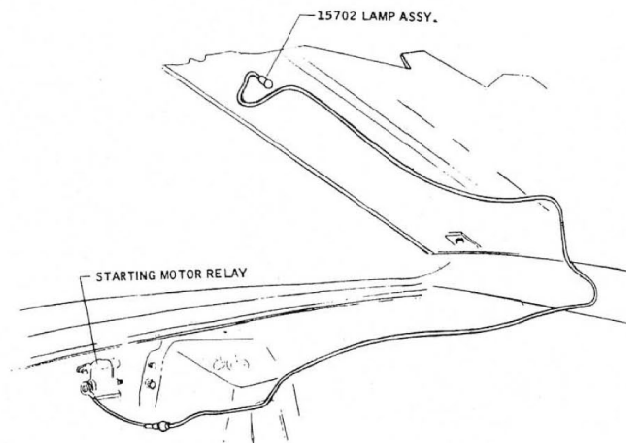

COUGAR-ENGINE COMPARTMENT LAMP

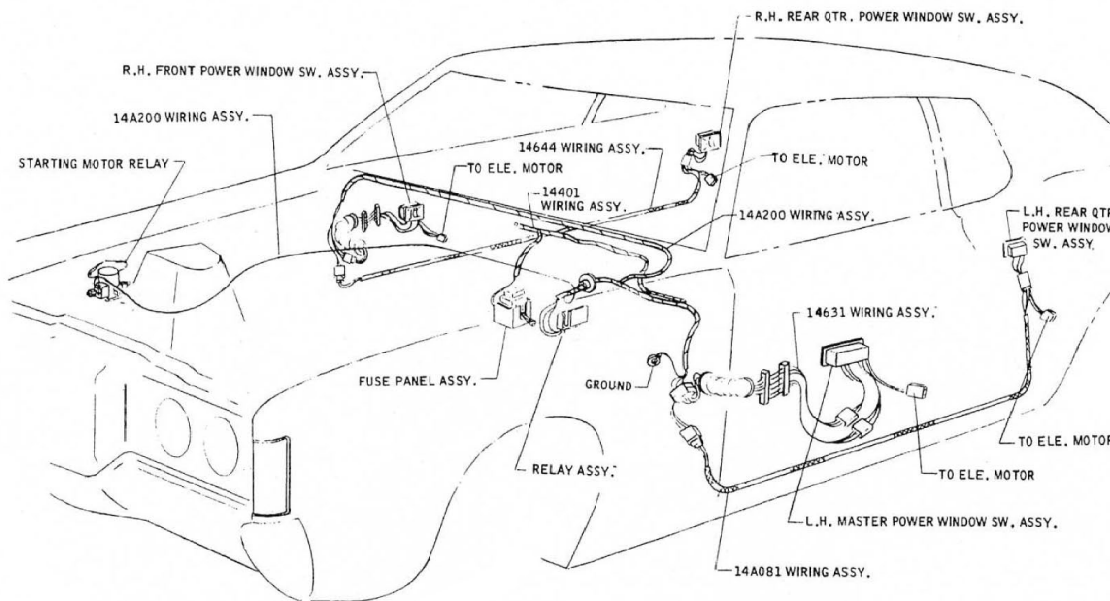

## MUSTANG AND COUGAR PICTORIALS

**BUY IT NOW!**  
Click Here To Order

100% SATISFACTION GUARANTEED

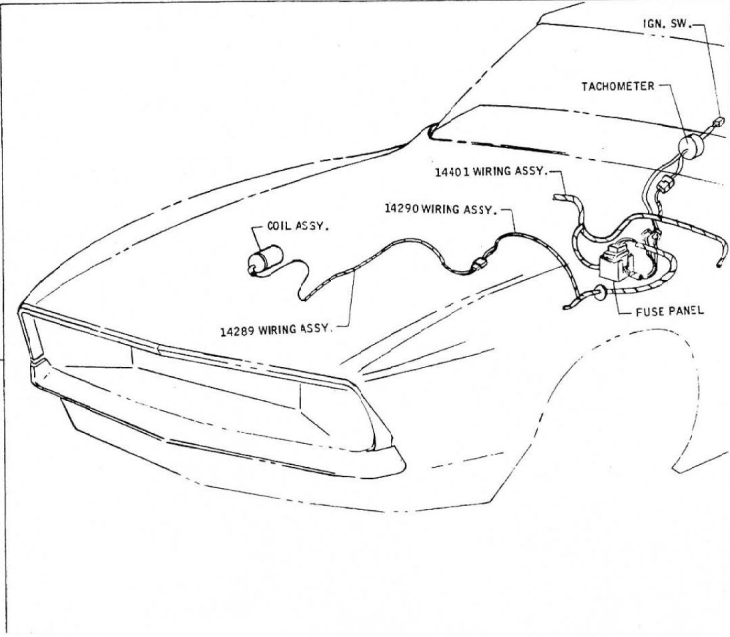
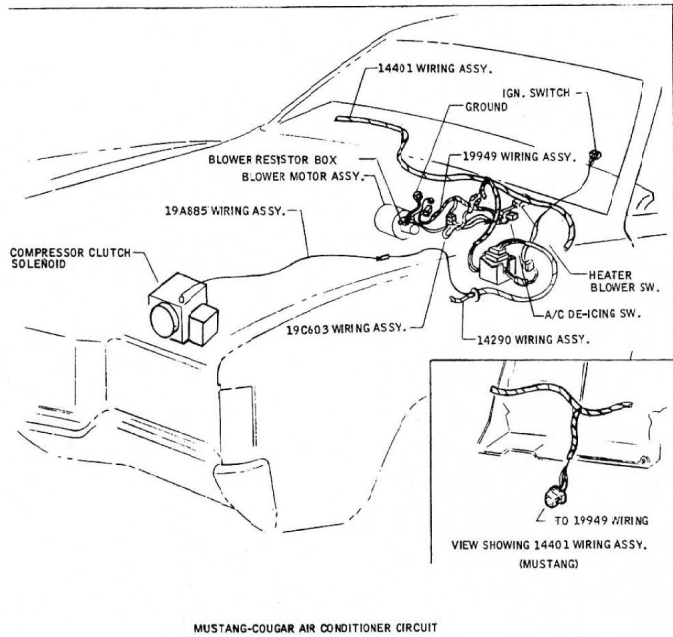
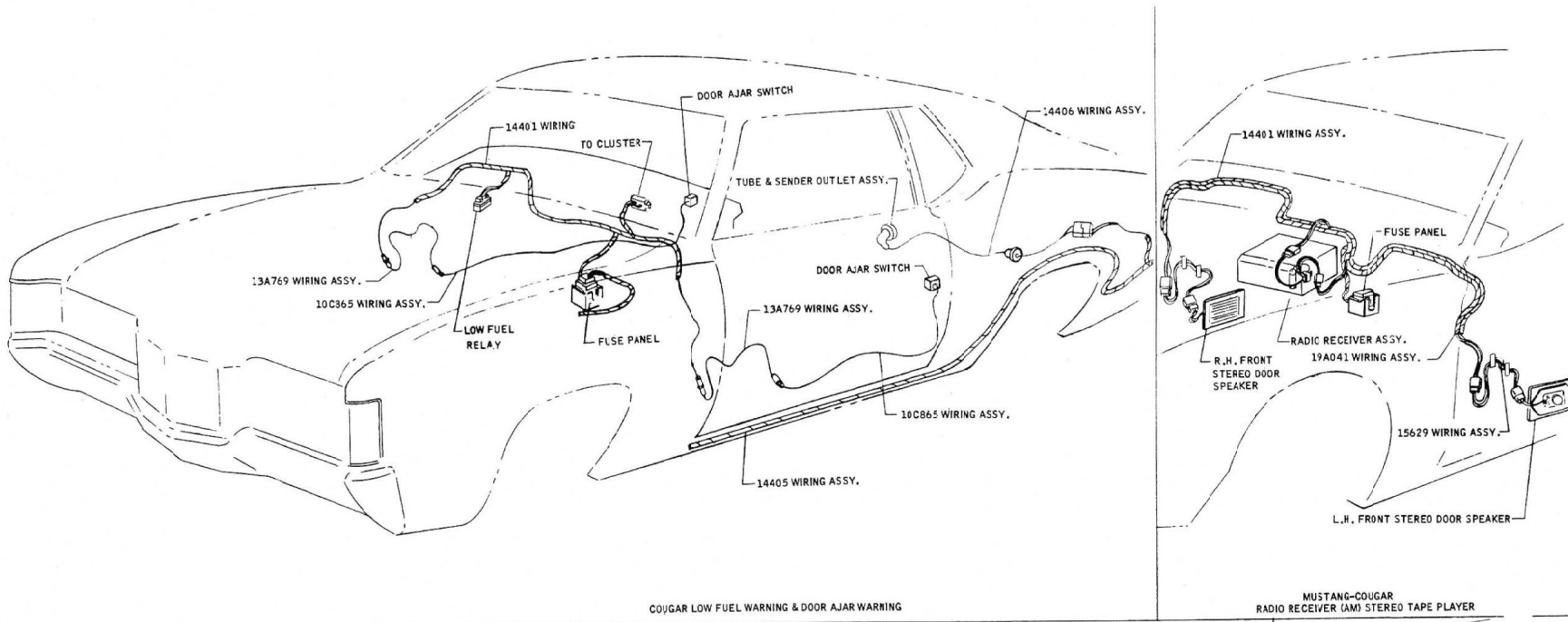

# MUSTANG AND COUGAR PICTORIALS

**BUY IT NOW!**

**Click Here To Order**

100% GUARANTEED SATISFACTION

VISA  
MasterCard  
Discover  
eBay  
PayPal

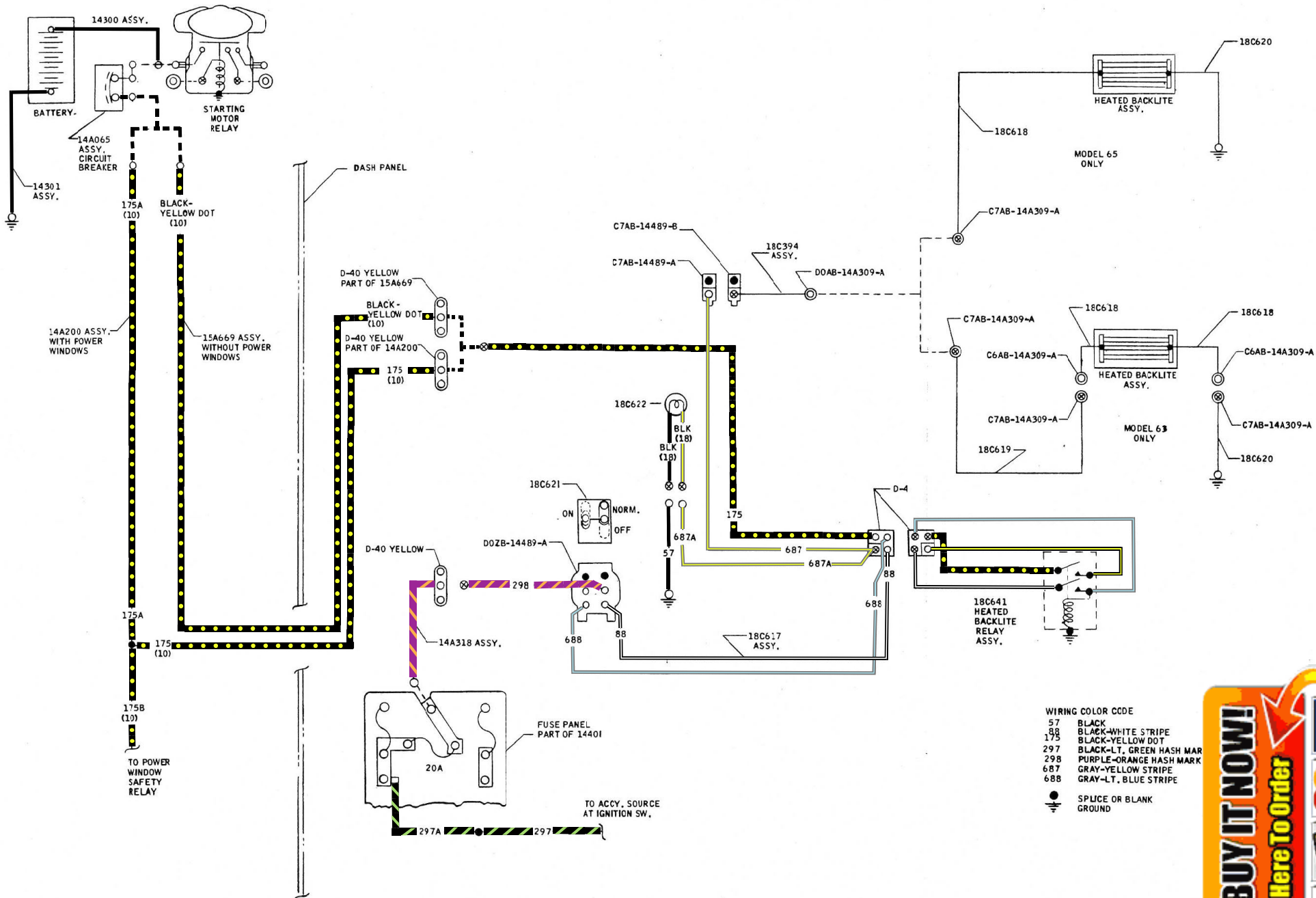

# MUSTANG HEATED BACKLITE

**BUY IT NOW!**

**Click Here To Order**

100% SATISFACTION GUARANTEE

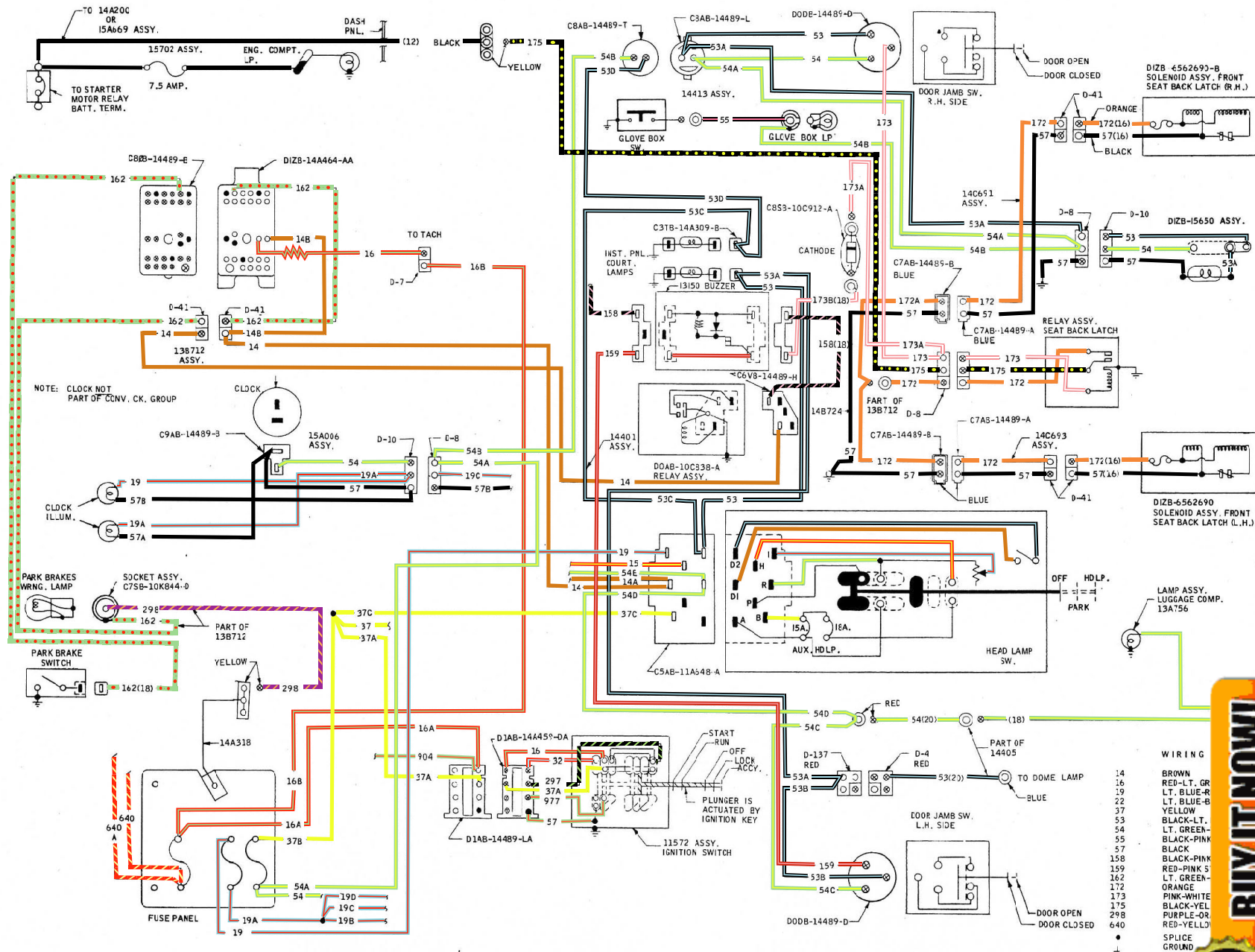

NOTE: CLOCK NOT PART OF CONV. CK. GROUP

- WIRING
- 14 BROWN
  - 16 RED-LT. GR
  - 19 LT. BLUE-R
  - 22 LT. BLUE-B
  - 37 YELLOW
  - 53 BLACK-LT.
  - 54 LT. GREEN
  - 55 BLACK-PINK
  - 57 BLACK
  - 158 BLACK-PINK
  - 159 RED-PINK 5
  - 162 LT. GREEN
  - 172 ORANGE
  - 173 PINK-WHITE
  - 175 BLACK-YEL
  - 298 PURPLE-OR
  - 640 RED-YEL(L)
  - SPLICE
  - + GROUND

# MUSTANG CONVENIENCE SYSTEM (With Tach)

**BUY IT NOW!**

Click Here To Order

100% SATISFACTION GUARANTEE

VISA  
MasterCard  
Discover  
eBay  
PayPal

Source Document  
Ford Publication Form 7795P-71

# 1971

COURSE 13003 and 1703

# WIRING and VACUUM DIAGRAMS



**SERVICE  
TRAINING**

FORM 77

**BUY IT NOW!**  
**Click Here To Order**

100% SATISFACTION GUARANTEE

PayPal  
MasterCard  
Discover  
VISA

A vertical promotional banner with a red and yellow background. It features a large white arrow pointing upwards. The text "BUY IT NOW!" and "Click Here To Order" is written in bold white letters. Below this is a circular seal with "100% SATISFACTION GUARANTEE" around the perimeter. At the bottom, there are logos for PayPal, MasterCard, Discover, and VISA.

# 1971 VACUUM SYSTEMS INDEX

## FORD-MERCURY-METEOR VACUUM SYSTEM

- INCLUDES FORCED VENT SYSTEM ..... V-2
- INCLUDES MANUAL AIR CONDITIONER ..... V-3
- INCLUDES AUTOMATIC TEMPERATURE CONTROL ..... V-4

## LINCOLN CONTINENTAL VACUUM SYSTEM ..... V-5

## MAVERICK-COMET VACUUM SYSTEM ..... V-6

## MUSTANG-COUGAR VACUUM SYSTEM ..... V-7

## PINTO VACUUM SYSTEM .....

## THUNDERBIRD-MARK III VACUUM SYSTEM .....

## TORINO-MONTEGO VACUUM SYSTEM .....

**BUY IT NOW!**  
Click Here To Order

VISA  
MasterCard  
Discover  
American Express  
PayPal

100% GUARANTEED  
SATISFACTION OR YOUR MONEY BACK

# HOW TO USE THE VACUUM DIAGRAMS

IF IT IS A FORD CAR LINE VACUUM SYSTEM, THE TECHNICIAN WILL FIND A PAGE FOR THE TOTAL SCHEMATIC SYSTEM AS WELL AS A LISTING FOR A SCHEMATIC AND PICTORIAL OF EACH SUBSYSTEM ON EACH SECTION INDEX PAGE. IT IS RECOMMENDED THAT THE TECHNICIAN FIRST TURN TO THE TOTAL SYSTEMS SCHEMATIC TO DETERMINE IF THERE ARE ANY BRANCH SYSTEMS OPERATING FROM THE SAME SOURCE. THIS WILL ASSIST IN LOCATING SYSTEM TROUBLES. HE WILL THEN BE ABLE TO TURN TO A PAGE TO FIND DETAILED INFORMATION ON A PARTICULAR SYSTEM. IN TRACING VACUUM SYSTEMS, IT IS RECOMMENDED THAT A CIRCUIT BE TRACED FROM ITS CONTROL UNIT TO ITS SOURCE OF VACUUM, AND THEN FROM THE CONTROL UNIT TO THE OPERATING UNIT, NOTING POINTS OF POSSIBLE MALFUNCTION AND ACCESSIBILITY.

THE VACUUM SYMBOLS AND THEIR MEANINGS ARE NOTED ON EACH DIVIDER PAGE TO PROVIDE A CLEAR UNDERSTANDING OF THE DIAGRAMS.

## VACUUM

### CIRCUIT SYMBOLS

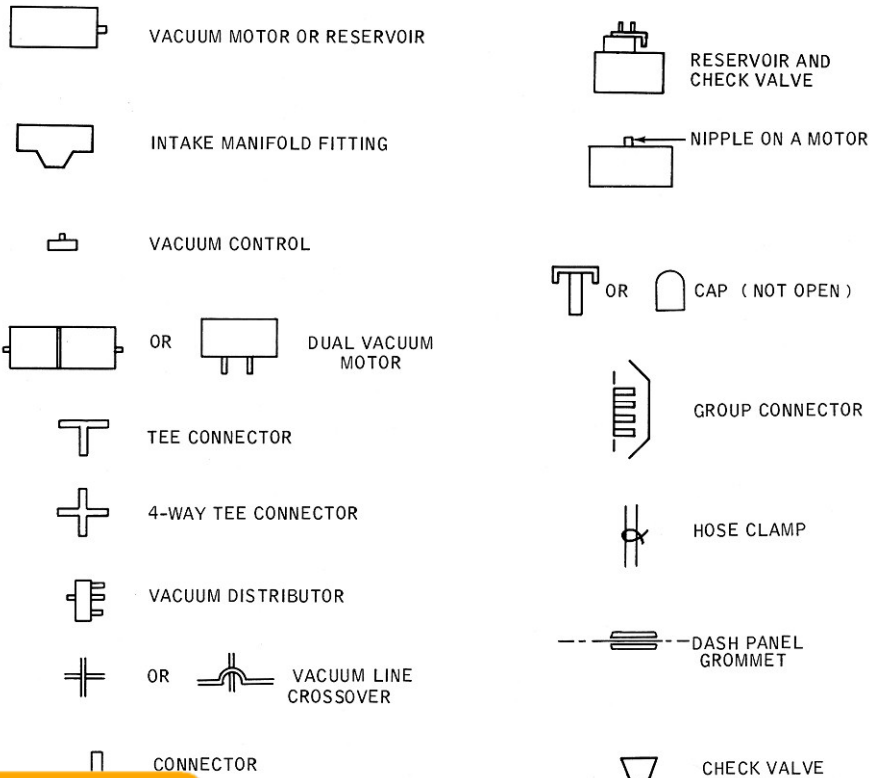

**BUY IT NOW!**

**Click Here To Order**



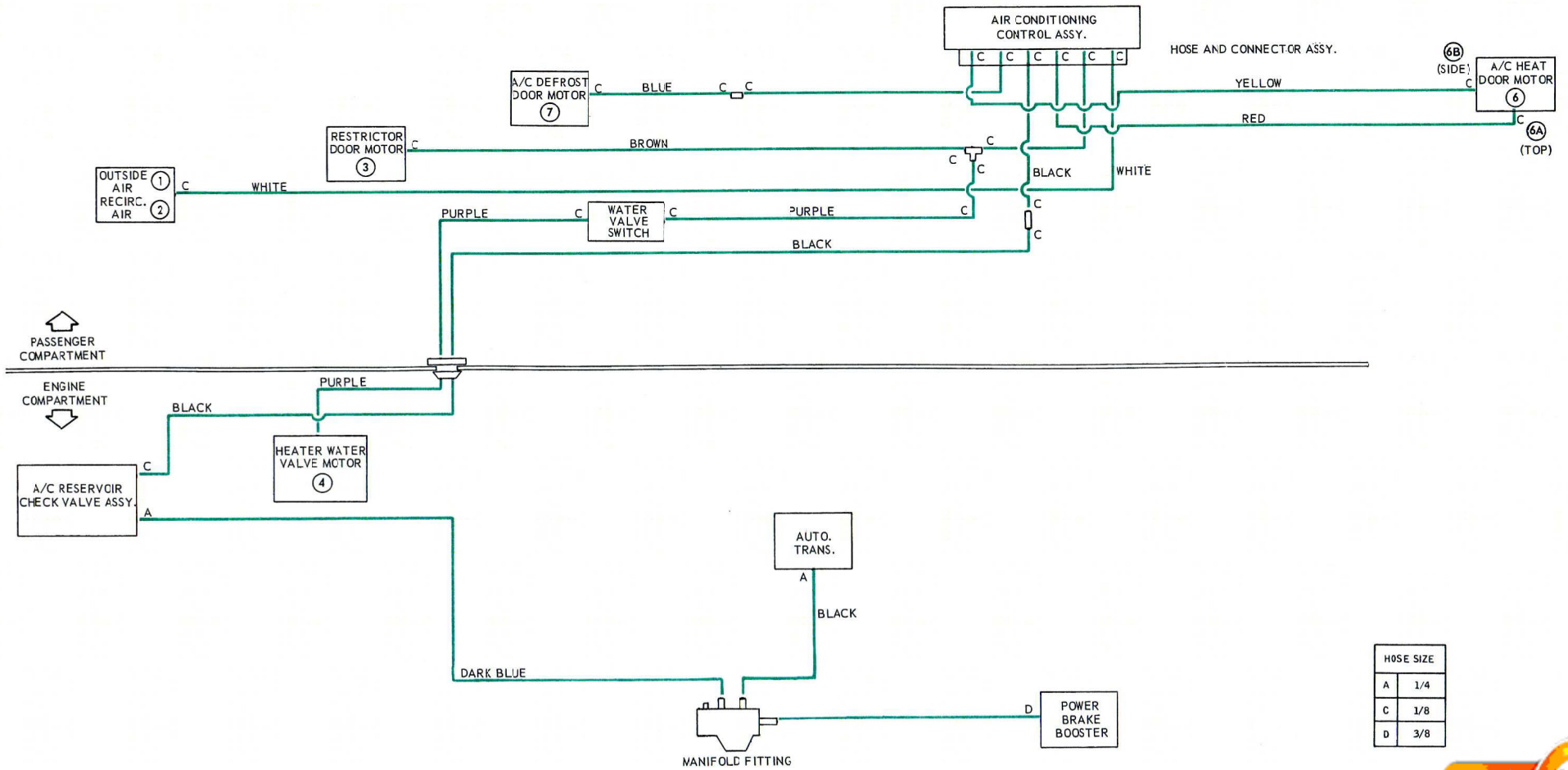

## MUSTANG-COUGAR VACUUM SYSTEMS

HOSE SIZE	
A	1/4
C	1/8
D	3/8

**BUY IT NOW!**

**Click Here To Order**

100% SATISFACTION GUARANTEED

VISA  
MasterCard  
Discover  
American Express  
PayPal

770

MAVERICK

TORINO

MUSTANG

FORD

THUNDERBIRD

MONTEGO

COUGAR

COMET

METEOR

MERCURY

LINCOLN  
CONTINENTAL

CONTINENTAL  
MARK III

# 1971

## CAR

# SHOP

# MANUAL

Source Document  
Ford Publication Form 7098-71-3

Includes all Five Volumes:

- Volume I - Chassis
- Volume II - Engine
- Volume III - Electrical
- Volume IV - Body
- Volume V - Pre-Delivery



**BUY IT NOW!**

Click Here To Order



IDENTIFICATION CODES . . . . .	10
WHEELS and TIRES . . . . .	11
BRAKES . . . . .	12
STEERING . . . . .	13
SUSPENSION . . . . .	14
DRIVING SHAFTS . . . . .	15
CLUTCH and MANUAL TRANSMISSION . . . . .	16
AUTOMATIC TRANSMISSION . . . . .	17

**VOLUME ONE**

IDENTIFICATION CODES . . . . .	20
GASOLINE ENGINES . . . . .	21
IGNITION SYSTEM . . . . .	23
FUEL SYSTEM . . . . .	24
EXHAUST SYSTEM . . . . .	26
COOLING SYSTEM . . . . .	27
STARTING SYSTEM . . . . .	28

**VOLUME TWO**

**VOLUME THREE ELECTRICAL**

IDENTIFICATION CODES . . . . .	40
SEATS . . . . .	41
WINDOW GLASS and MECHANISMS . . . . .	42
STATIONARY WINDOW GLASS . . . . .	43
DOORS, HOOD, LUG PARTS and . . . . .	44
INTERIOR TRIM . . . . .	45
TOPS and EXTERIOR FINISHES . . . . .	46
BODY SHELL, EXTERIOR TRIM, FRAME AND UNDERBODY . . . . .	47

**VOLUME FOUR**

MAINTENANCE and LUBRICATION . . . . .	50
---------------------------------------	----

**VOLUME FIVE**

# GROUP INDEX

IDENTIFICATION CODES **30**

CHARGING SYSTEM **31**

LIGHTING SYSTEM **32**

INSTRUMENTS, CLUSTERS and CONTROLS **33**

MAIN WIRING HARNESSSES and CIRCUIT PROTECTION **34**

AUXILIARY EQUIPMENT **35**

VENTILATING HEATING and AIR CONDITIONING **36**

SPEED CONTROL and ANTI-SKID CONTROL **37**



**BUY IT NOW!**

**Click Here To Order**

FIRST PRINTING—SEPTEMBER, 1970

© 1970 FORD MARKETING CORPORATION, DEARBORN, MICHIGAN



## FOREWORD

*This manual is divided into five volumes: 1 – Chassis, 2 – Engine, 3 – Electrical, 4 – Body, 5 – Maintenance and Lubrication. These volumes should provide Service Technicians with complete information covering normal service repairs on all 1971 model passenger cars (except Pinto) built by the Ford Companies in the U. S. and Canada. Service procedures for the Pinto are covered in the Pinto Car Shop Manual. As changes in the product occur, this information will be updated by Technical Service Bulletins. When issued, TSB information always supersedes that published herein.*

*Within each volume, information is grouped by system or component plus “General Service” parts which contain information which is common to several similar components.*

*The table of contents on the first page of each volume indicates the general content of the book and provides a handy tab locator to make it easy to find the first page of each “Group”. That page will contain an index to “Parts” and the first page of each “Part” contains a detailed index which gives page location for each service operation covered. Page numbers are consecutive in each “Part”.*

*To make reference easier, information has been broken down into smaller units so that essentially there is now one “Part” for each component or system. Group numbers indicate the volume in which the group may be found.*

Indicates:

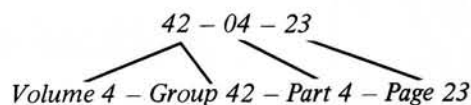

*The descriptions and specifications in this manual were in effect at the time this manual was approved for printing. Ford Marketing Corporation reserves the right to discontinue models at any time, or change specifications or design, without notice and without incurring obligation.*

 **SERVICE PUBLICATIONS**

 **BUY IT NOW!**  
**Click Here To Order** 

# Identification Codes

GROUP  
**30**

## PART 30-01 Car Identification Codes

### OFFICIAL VEHICLE IDENTIFICATION NUMBER

The official Vehicle Identification Number (VIN) for title and registra-

tion purposes is stamped on a metal tab that is riveted to the instrument panel close to the windshield on the driver's side of the car and is visible from outside (Fig. 1).



MANUFACTURED BY FORD MOTOR COMPANY 100001

08/70 THIS VEHICLE CONFORMS TO ALL APPLICABLE FEDERAL MOTOR VEHICLE SAFETY STANDARDS IN EFFECT ON DATE OF MANUFACTURE SHOWN ABOVE.

VEH. IDENT. NO.		BODY	COL.
1S53F100001		54D	A
TRIM	AXLE	TRNS.	DSO
3A	2	W	33

NOT FOR TITLE OR REGISTRATION

MADE IN U.S.A.

NOTE: WORDING WILL VARY WITH VEHICLE LINE

- ① CONSECUTIVE UNIT NO.
- ② BODY SERIAL CODE
- ③ MODEL YEAR CODE
- ④ ASSEMBLY PLANT CODE
- ⑤ ENGINE CODE
- ⑥ TRIM CODE
- ⑦ REAR AXLE CODE
- ⑧ COLOR CODE
- ⑨ BODY TYPE CODE
- ⑩ DISTRICT - SPECIAL EQUIPMENT CODE
- ⑪ TRANSMISSION CODE

### VEHICLE CERTIFICATION LABEL

The Vehicle Certification Label (V.C. Label) is attached to the rear face of the driver's door. The upper half of the label contains the name of the manufacturer, the month and year of manufacture and the certification statement. The V.C. label also contains the Vehicle Identification Number. This number is also used for Warranty identification of the vehicle. The first number indicates the model year. The letter following the model year number indicates the manufacturing assembly plant. The next two numbers designate the Body Serial Code followed by a letter expressing the Engine Code. The last six digits of the Vehicle Identification Number indicate the Consecutive Unit Number.

The remaining information on the V.C. Label consists of pertinent vehicle identification codes. The **BODY** code is two numerals and a letter identifying the body style. The **COL** (color) code is a number or letter (or both) indicating the exterior paint color code. The **TRIM** code consists of a number-letter combination designating the interior trim. The axle code is a number or letter indicating the rear axle ratio and standard or locking type axles. The **TRNS.** code is a number or letter indicating the type of transmission, numerals for manual and letters for automatic. The **DSO** code consisting of two numbers designates the district in which the car was ordered and may appear in conjunction with a Domestic Special Order or Foreign Special Order number when applicable. Ford of Canada **DSO** codes consist of a letter and a number.

### MODEL YEAR CODE

The number 1 designates 1971.

Y 1298 - A

**100% SATISFACTION GUARANTEED**

**BUY IT NOW!**

**Click Here To Order**

PayPal, American Express, Discover, MasterCard, VISA

and Identification Number

**CONSECUTIVE UNIT NUMBER**

Starting Serial Numbers—1971  
Passenger Cars

100,001—Ford, Torino, Mustang,  
Thunderbird, Maverick

500,001—Mercury, Meteor,  
Montego, Cougar, Comet

800,001—Lincoln Continental &  
Continental Mark III

ASSEMBLY PLANT CODES

Code Letter	
A.....	Atlanta
B.....	Oakville (Canada)
E.....	Mahwah
F.....	Dearborn
G.....	Chicago
H.....	Lorain
J.....	Los Angeles
K.....	Kansas City
N.....	Norfolk
P.....	Twin Cities
R.....	San Jose
S.....	Allen Park
T.....	Metuchen
U.....	Louisville
W.....	Wayne
X.....	St. Thomas
Y.....	Wixom

CY-1299-A

**DATE CODES**

A number signifying the date preceeds the month code letter. A second-year code letter will be used if the model exceeds 12 months.

Month	Code First Year	Code Second Year
January.....	A.....	N
February.....	B.....	P
March.....	C.....	Q
April.....	D.....	R
May.....	E.....	S
June.....	F.....	T
July.....	G.....	U
August.....	H.....	V
September.....	J.....	W
October.....	K.....	X
November.....	L.....	Y
December.....	M.....	Z

**DISTRICT CODES (DSO)**

Units built on a Domestic Special Order, Foreign Special Order, or other Special orders will have the complete order number in this space. Also to appear in this space is the two-digit code number of the District which ordered the unit. If the unit is a regular production unit, only the District code number will appear.

**FORD**

Code	District
11.....	Boston
13.....	New York
15.....	Newark
16.....	Philadelphia
17.....	Washington
21.....	Atlanta
22.....	Charlotte
24.....	Jacksonville
25.....	Richmond
28.....	Louisville
32.....	Cleveland
33.....	Detroit
35.....	Lansing
37.....	Buffalo
38.....	Pittsburgh
41.....	Chicago
43.....	Milwaukee
44.....	Twin Cities
46.....	Indianapolis
47.....	Cincinnati
51.....	Denver
53.....	Kansas City
54.....	Omaha
55.....	St. Louis
56.....	Davenport
61.....	Dallas
62.....	Houston
63.....	Memphis
64.....	New Orleans
65.....	Oklahoma City
71.....	Los Angeles
72.....	San Jose
73.....	Salt Lake City
74.....	Seattle
75.....	Phoenix
83.....	Government
84.....	Home Office Reserve
85.....	American Red Cross
89.....	Transportation Services
90-99.....	Export

**LINCOLN-MERCURY**

Code	District
11.....	Boston
15.....	New York
16.....	Philadelphia
17.....	Washington
21.....	Atlanta
22.....	Dallas
23.....	Jacksonville
26.....	Memphis
31.....	Buffalo
32.....	Cincinnati
33.....	Cleveland
34.....	Detroit
41.....	Chicago
42.....	St. Louis
46.....	Twin Cities
51.....	Denver
52.....	Los Angeles
53.....	Oakland
54.....	Seattle
84.....	Home Office Reserve
90.....	Export

**FORD OF CANADA**

Code	District
B1.....	Central
B2.....	Eastern
B3.....	Atlantic
11 thru 17.....	Export
B4.....	Midwestern
B6.....	Western
B7.....	Pacific

Note: Canadian Lincoln-Mercury units use prefix "A" in place of "B".

CK2456-B

**100% SATISFACTION GUARANTEED**

**BUY IT NOW!**

**Click Here To Order**

PayPal   Discover   MasterCard   VISA

<h1 style="margin: 0;">Charging System</h1>	<p><b>GROUP</b></p> <h1 style="margin: 0;">31</h1>
---	--

<p><b>PART 31-01</b> PAGE Charging System General Service .. <b>31-01-01</b></p> <p><b>PART 31-02</b> Batteries ..... <b>31-02-01</b></p> <p><b>PART 31-10</b> Autolite Alternators ..... <b>31-10-01</b></p>	<p><b>PART 31-21</b> PAGE Leece-Neville Alternators ..... <b>31-21-01</b></p> <p><b>PART 31-40</b> Autolite Alternator Regulator ..... <b>31-40-01</b></p> <p><b>PART 31-42</b> Leece-Neville Alternator Regulator ..... <b>31-42-01</b></p>
---	--

## PART 31-01 Charging System General Service

COMPONENT INDEX	PAGE	COMPONENT INDEX	PAGE
DESCRIPTION AND OPERATION .....	31-01-01	TESTING .....	31-01-01
Fuse Link - Charging System .....	31-01-01	Charging System .....	31-01-01
REMOVAL AND INSTALLATION .....	31-01-02	Fuse Link Continuity Test .....	31-01-02
Fuse Link Replacement .....	31-01-02		

### 1 DESCRIPTION AND OPERATION

#### CHARGING SYSTEM FUSE LINK

The fuse link is a short length of insulated wire integral with the engine compartment wiring harness. It is several wire gages smaller than the circuit that it protects. Production fuse links are black. Service fuse links are green or black depending on usage. All

fuse links have the words FUSE LINK printed on the insulation. Fig. 1 shows fuse link installations.

The fuse link burns out, thus protecting the alternator or wiring, when heavy current flows, such as when a booster battery is connected incorrectly or a short to ground occurs

in the wiring harness.

A burned out link may have bare wire ends protruding from the insulation, or it may only have expanded or bubbled insulation with illegible identification. If it is hard to determine if the link is burned out, perform a continuity test.



BUY IT NOW!

Click Here To Order



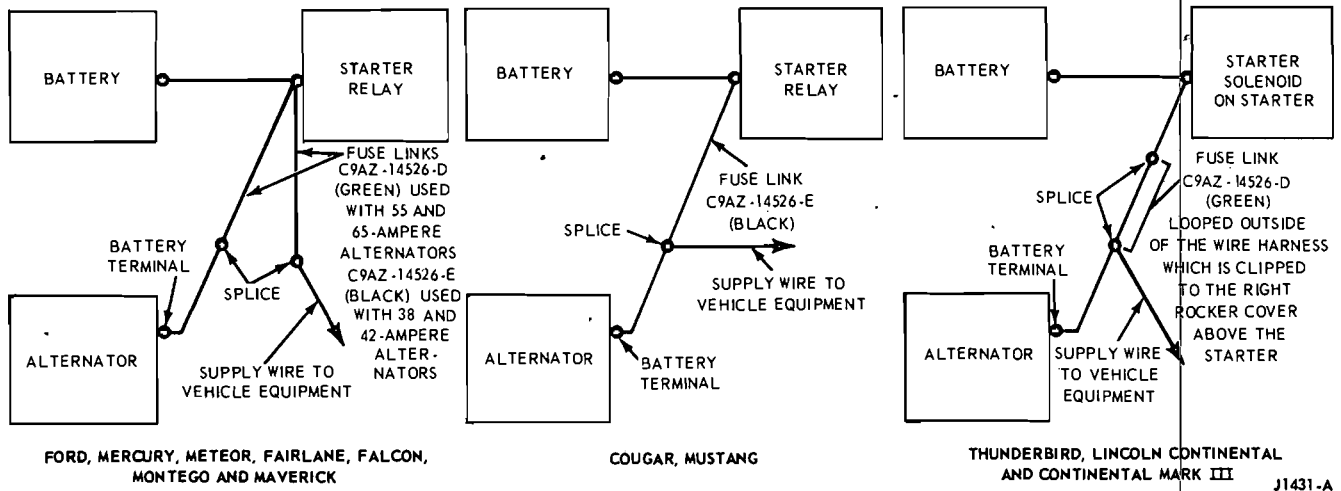

FIG. 1 Fuse Link Installation

## 2 TESTING

### CHARGING SYSTEM

The alternator and alternator regulator are precision built units, and the equipment to make tests in the charging system must be accurate. Voltmeters must be accurate within 0.1 (one tenth) volt within the range of 12 to 16 volts and ammeters within one ampere at 30 to 65 amperes to permit correct measurement of the alternator and regulator. The meters on Rotunda equipment should be calibrated once a year and the date of calibration stamped on the meter face. It is recommended that this practice be followed by technicians with other than approved equipment in order to maintain their meters at acceptable accuracy.

Certain tests outlined in this section are illustrated in schematic and in pictorial form. The schematic illustrates the internal connections of the Rotunda equipment so that these connections can be duplicated when this equipment is not available. The

Rotunda test units are a combination of accepted instruments incorporated into a single unit. The various circuits involved in the tests can be selected by means of switches without the necessity of changing connections. This reduces the time required to test units and circuits on the vehicle.

Where applicable, the tests are divided into On The Vehicle and On The Test Bench procedures. Either procedure can be followed depending on the equipment available for the tests.

Trouble shooting or diagnosis is required before actual repairs can be made in the electrical system. Even where an obvious fault makes the replacement of a unit necessary, you must still find out why the unit failed. The trouble shooting procedures given in the Electrical Systems Diagnosis Manual will aid in making a correct diagnosis. When a trouble is diagnosed correctly, unnecessary repairs are prevented, the time the vehicle is out of service will be decreased, and the

repairs that are made will be permanent.

### FUSE LINK CONTINUITY TEST

1. On the Cougar, Mustang, Thunderbird, Lincoln Continental and Continental Mark III, make certain first that the battery is OK, then turn on the headlights or any accessory. If the headlights or accessory do not operate, the fuse link is probably burned out.

2. On the Ford, Mercury, Meteor, Torino, Montego, Maverick and Comet, there are two fuse links (Fig. 1). Use the same procedure as in step 1 to test the fuse link that protects the vehicle equipment.

To test the fuse link that protects the alternator, make certain that the battery is OK then check with a voltmeter for voltage at the BAT terminal of the alternator. No voltage indicates that the fuse link is probably turned out.

## 4 REMOVAL AND INSTALLATION

stud on one end. When the terminal is not required, cut off the fuse link as close to the terminal as possible and strip approximately 3/8-inch of insulation from the cut end.

2. Disconnect the battery ground cable.

3. Disconnect the fuse link and/or fuse link eyelet terminal from the battery terminal of the starter

**100% SATISFACTION GUARANTEED**

**BUY IT NOW!**

**Click Here To Order**

PayPal, American Express, Discover, MasterCard, VISA

relay. On the Thunderbird, Lincoln Continental and the Continental Mark III, the fuse link is looped outside of the wire harness behind the point at which the harness is clipped to the right rocker cover above the starter.

4. Cut the fuse link and the

splice(s) from the wire(s) to which it is attached.

5. Splice and solder the new fuse link to the wire(s) from which the old link was cut. Use rosin core solder. Wrap the splice(s) completely with vinyl electricians tape.

6. Securely connect the eyelet terminals (if any) to the battery stud on the starter relay.

7. Install the repaired wiring as before using existing clips if provided.

8. Connect the ground cable to the battery.

1



**100% SATISFACTION GUARANTEED**

**BUY IT NOW!**

**Click Here To Order**

PayPal American Express Cards DISCOVER NOVUS MasterCard VISA

# PART 31-02 Batteries

COMPONENT INDEX	PAGE	COMPONENT INDEX	PAGE
SPECIFICATIONS .....	31-02-03	TESTING.....	31-02-01
		With Rotunda Battery-Starter Tester (Are 16-31).....	31-02-02
		With Rotunda Cell Analyzer (SRECA-200).....	31-02-01

## 2 TESTING

Tests are made on a battery to determine the state of charge and also the condition. The ultimate result of these tests is to show that the battery is good, needs recharging, or should be replaced.

If a battery has failed, is low in charge, or requires water frequently, good service demands that the reason for this condition be found. It may be necessary to follow trouble shooting procedures to locate the cause of the

trouble. Refer to the Ford Car and Truck Diagnosis Manual for battery diagnosis procedures.

Hydrogen and oxygen gases are produced during normal battery operation. This gas mixture can explode if flames or sparks are brought near the vent openings of the battery. The sulphuric acid in the battery electrolyte can cause a serious burn if spilled on the skin or spattered in the eyes. It should be flushed away

with large quantities of clear water.

Particular care should be used when connecting a booster battery in order to prevent sparks. Be certain to connect positive terminal to positive terminal and negative terminal to negative terminal.

Before attempting to test a battery, it is important that it be given a thorough visual examination to determine if it has been damaged. The presence of moisture on the outside of the case and/or low electrolyte level in one or more of the cells are indications of possible battery damage.

Autolite batteries have a single one-piece cover which completely seals the top of the battery and the individual cell connectors. This cover must not be pierced with test probes to perform individual cell tests.

### TESTS USING THE ROTUNDA CELL ANALYZER (SRECA-200)

The Rotunda Cell Analyzer (SRECA-200) measures the individual cell voltages by inserting probes into the cell openings. Follow the instructions provided with the unit.

A battery can also be tested by determining its ability to deliver current. This may be determined by conducting a Battery Capacity Test. Fig. 1 shows the battery capacity test in outline form.

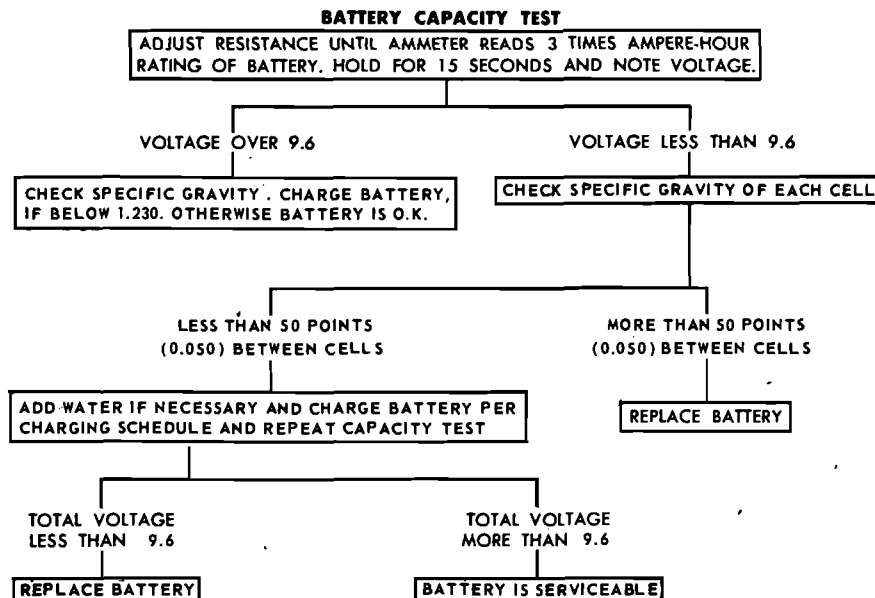

J1039-F

**100% SATISFACTORY GUARANTEED**

**BUY IT NOW!**

**Click Here To Order**

PayPal American Express Discover MasterCard VISA

**TESTS USING THE ROTUNDA BATTERY—STARTER TESTER ARE 16-31**

**Battery Capacity Test**

A high rate discharge tester (Rotunda Battery-Starter Tester ARE 16-31) in conjunction with a voltmeter is used for this test.

1. Turn the control knob on the Battery Starter Tester to the OFF position.

2. Turn the voltmeter selector switch to the 20-volt position.

3. Connect both positive test leads to the positive battery post and both negative test leads to the negative battery post. **The voltmeter clips must contact the battery posts and not the high rate discharge tester clips. Unless this is done, the actual battery terminal voltage will not be indicated.**

4. Turn the load control knob in a clockwise direction until the ammeter reads three times the ampere hour rating of the battery. (A 45 ampere-hour battery should be tested at 135 amperes load).

5. With the ammeter reading the required load for 15 seconds, note the voltmeter reading. **Avoid leaving the high discharge load on the battery for periods longer than 15 seconds.**

6. If the voltmeter reading is 9.6 volts or more, the battery has good output capacity and will readily accept a charge, if required. Check the specific gravity. If the specific gravity reading is 1.230 or below, add water if necessary and charge the battery until it is fully charged (Fig. 1). **Always disconnect the battery ground cable**

Specific Gravity Reading	Charge Rate Amperes	Battery Capacity – Ampere Hours				
		45	55	70	80	85
1.125–1.150 ①	35	65 min.	80 min.	100 min.	115 min.	125 min.
1.150–1.175	35	50 min.	65 min.	80 min.	95 min.	105 min.
1.175–1.200	35	40 min.	50 min.	60 min.	70 min.	75 min.
1.200–1.225	35	30 min.	35 min.	45 min.	50 min.	55 min.
Above 1.225	5	②	②	②	②	②

① If the specific gravity is below 1.125, use the indicated high rate of charge for the 1.125 specific gravity, then charge at 5 amperes until the specific gravity reaches 1.250 at 80° F.  
 ② Charge at 5 ampere rate only until the specific gravity reaches 1.250 at 80° F. At no time during the charging operation should the electrolyte temperature exceed 130° F.

J 1355-C

FIG. 2 Allowable Battery High Rate Charge Time Schedule

when charging the battery.

**The battery is fully charged when the cells are all gassing freely and the specific gravity ceases to rise for three successive readings taken at hourly intervals. Additional battery testing will not be necessary after the battery has been properly charged.**

7. If the voltage reading obtained during the capacity test is below 9.6 volts, check the specific gravity of each cell.

8. If the difference between any two cells is more than 50 points (0.050), the battery is not satisfactory for service and should be replaced.

9. If the difference between cells is less than 50 points (0.050), the battery should be charged according to the charging schedule in Fig. 2. In some cases the electrolyte level may be

too low to obtain a specific gravity reading. In such cases water should be added until the electrolyte level just covers the ring in the filler well, then charge the battery at 35 amperes for the maximum charging time indicated in Fig. 2 for the capacity of the battery being tested.

10. After the battery has been charged, repeat the capacity test. If the capacity test battery voltage is still less than 9.6 volts, replace the battery. If the voltage is 9.6 volts or more, the battery is satisfactory for service.

11. If the battery is found to be discharged only, check for a loose fan belt, loose electrical connections and charging system performance.

**100% SATISFACTION GUARANTEED**  
**BUY IT NOW!**  
 Click Here To Order

PayPal, Discover, MasterCard, VISA

# 9 SPECIFICATIONS

## BATTERIES

Allowable Battery High Rate Charge Time Schedule						
Specific Gravity Reading	Charge Rate Amperes	Battery Capacity—Ampere Hours				
		45	55	70	80	85
1.125–1.150Ⓞ	35	65 min.	80 min.	100 min.	115 min.	125 min.
1.150–1.175	35	50 min.	65 min.	80 min.	95 min.	105 min.
1.175–1.200	35	40 min.	50 min.	60 min.	70 min.	75 min.
1.200–1.225	35	30 min.	35 min.	45 min.	50 min.	55 min.
Above 1.225	5	ⓐ	ⓐ	ⓐ	ⓐ	ⓐ

Ⓞ If the specific gravity is below 1.125, use the indicated high rate of charge for the 1.125 specific gravity, then charge at 5 amperes until the specific gravity reaches 1.250 at 80° F.  
 ⓐ Charge at 5 ampere rate only until the specific gravity reaches 1.250 at 80° F.  
 At no time during the charging operation should the electrolyte temperature exceed 130° F.

Battery Freezing Temperatures			
Specific Gravity	Freezing Temp	Specific Gravity	Freezing Temp
1.280	-90°F	1.150	+5°F
1.250	-62°F	1.100	+19°F
1.200	-16°F	1.050	+27°F

Battery Ampere Hours	Number Of Plates
45	54
55	66
70	66
80	78

CJ1447-A



**BUY IT NOW!**  
 Click Here To Order



# 1965/72 FORD CAR

FINAL ISSUE

Master Parts and Accessories

Source Document  
Ford Publication Form FP-7635-B

Form FP 7635-A & B

Supersedes All Previous Issues, Changes and Revisions



Official Licensed Product

5236

**FINAL ISSUE**



**BUY IT NOW!**

**Click Here To Order**

Copyright 1975 --

FORD MOTOR  
COMPANY

-- DEARBORN, MICHIGAN

PayPal

Discover  
Cards

Discover  
Novus

MasterCard

VISA



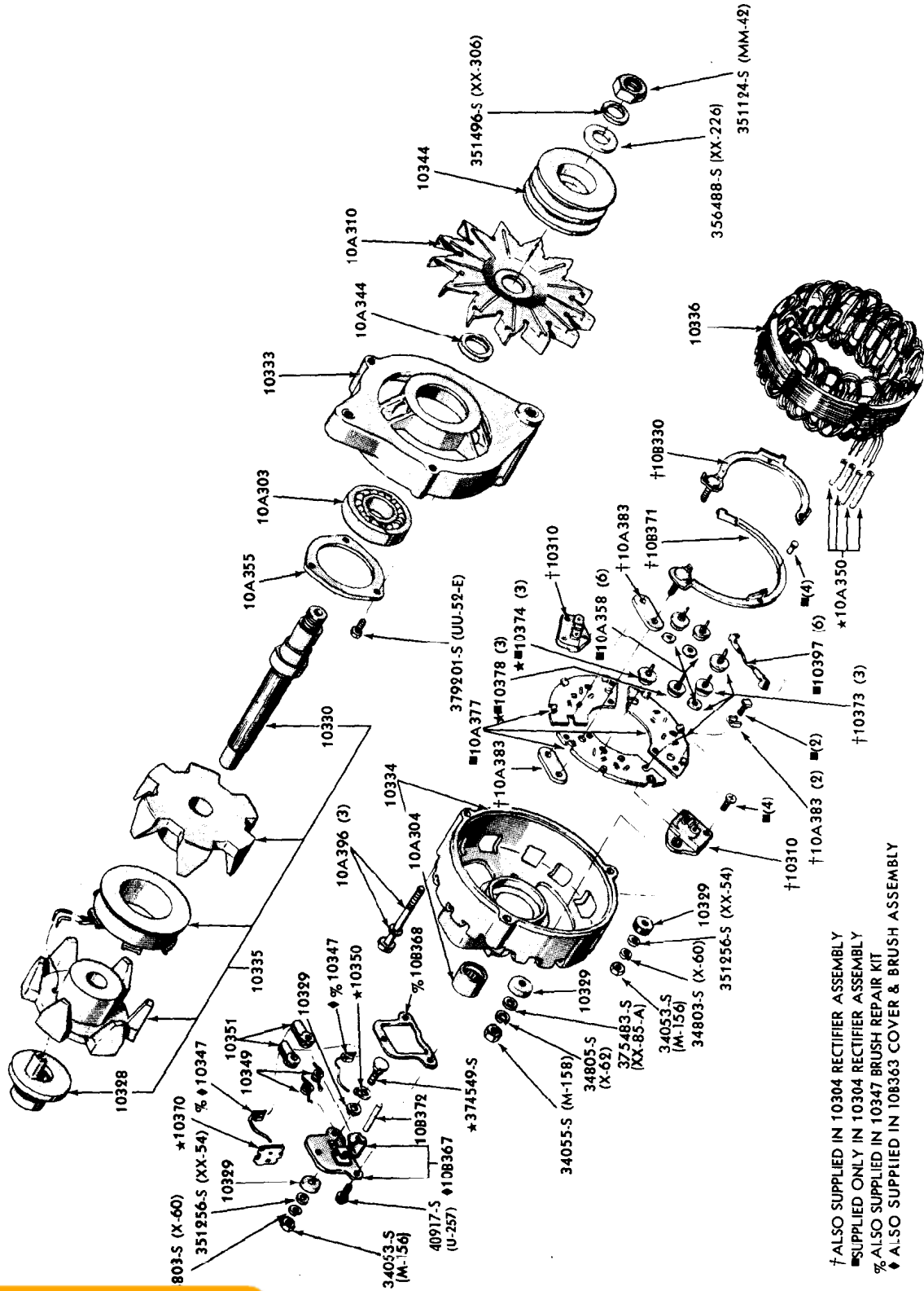

† ALSO SUPPLIED IN 10304 RECTIFIER ASSEMBLY  
 ▣ SUPPLIED ONLY IN 10304 RECTIFIER ASSEMBLY  
 % ALSO SUPPLIED IN 10347 BRUSH REPAIR KIT  
 † ALSO SUPPLIED IN 10B363 COVER & BRUSH ASSEMBLY

ALTERNATOR (FORD 15 VOLT - 65 AMP.)  
 1967/72

**100% SATISFACTION GUARANTEED**

**BUY IT NOW!**

**Click Here To Order**



READY REFERENCE

13001

# HOW TO READ WIRING DIAGRAMS



VOL 68 S7 L2A

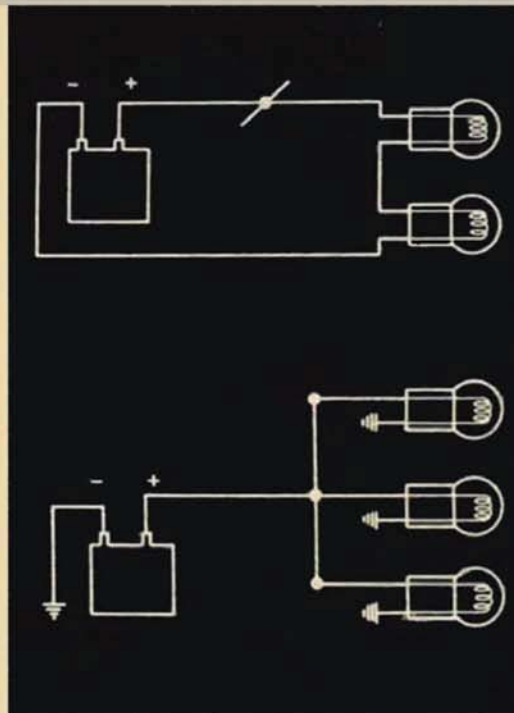

**BUY IT NOW!**

**Click Here To Order**



# HOW TO READ WIRING DIAGRAMS

COURSE 13001 • VOL. 68 S7 L2A

## TABLE OF CONTENTS

Page

### INTRODUCTION

<b>A LOGICAL APPROACH TO ELECTRICAL DIAGNOSIS . . . . .</b>	<b>1</b>
Like reading a road map . . . . .	2
How wires are numbered and color-coded . . . . .	2
<b>CIRCUIT – A COMPLETE ELECTRICAL PATH BETWEEN TWO POINTS . . . . .</b>	<b>5</b>
2-wire circuit . . . . .	6
Single wire circuit . . . . .	6
Ground connections . . . . .	7
<b>OPEN CIRCUITS . . . . .</b>	<b>8</b>
Shorts . . . . .	9
Grounded circuit . . . . .	9
Series and parallel open circuits . . . . .	10
<b>BREAKS IN PARALLEL CIRCUITS . . . . .</b>	<b>11</b>
Common points . . . . .	14
Splices . . . . .	15
Fuses and circuit breakers . . . . .	17
Quick disconnects . . . . .	18
Male and female elements . . . . .	20
Types of quick disconnects . . . . .	22
<b>HINTS FOR TRACING WIRES THROUGH A DRAWING . . . . .</b>	<b>23</b>
Curve directions . . . . .	23
Common points . . . . .	24
Switches . . . . .	25
Relays . . . . .	26
Assemblies . . . . .	28
Locating the assembly . . . . .	29
Finding the wire . . . . .	30
<b>SUMMARY . . . . .</b>	<b>31</b>

100% SATISFACTION GUARANTEED

The descriptions, testing procedures, and specifications in this handbook were approved for printing. Ford Motor Company reserves the right to change specifications without notice and without incurring liability.

**BUY IT NOW!**

Click Here To Order

NATIONAL SERVICE OFFICE  
FORD DIVISION



FIRST PRINTING – JANUARY, 1968

© 1968 FORD MOTOR COMPANY  
DEARBORN, MICHIGAN

# INTRODUCTION

## *The Why and Wherefore of Wiring Diagrams*

To the uninformed, a wiring diagram — or a wiring assembly — looks like it might take a genius to figure out.

Not so — as you'll find out when you get better acquainted with these subjects.

There're as understandable and logical as a road map and road markers, when you're finding your way on a cross-country drive.

The ability to read a wiring diagram and relate it to a vehicle's wiring system is, of course, an essential part of a modern service technician's skill. And it's growing in relative importance, too, due to owner's increasing demands for the comforts and conveniences supplied by electrically-operated options and accessories. This opens up greater opportunities, for the forward-looking technician.

## *The Purpose of this Booklet . . .*

. . . is to acquaint you with the systems by which electrical circuits are traced on vehicles. Specifically, it is designed to help you acquire the ability to make your own power checks, quickly and accurately.

## *Scope of the Booklet*

Basically, this is a printed version of the film, "How to Read a Wiring Diagram." It is in no sense a manual of the shop methods by which electrical repairs are made.

It *can* be a helpful guide that can introduce you to the principles of wiring diagrams and vehicle wiring. As you gain experience in reading wiring diagrams, you'll accumulate your own know-how in this important skill. When it becomes "second nature" to you, these pages will have served their purpose — and yours.



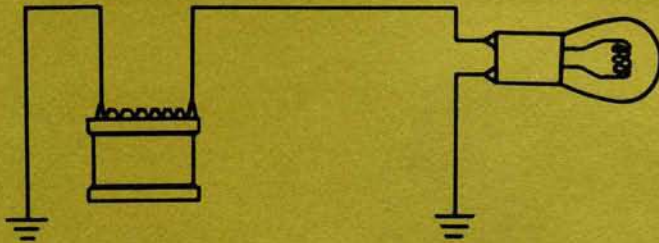

To show how to read wiring diagrams — and to explain how they can be used to help you troubleshoot problems in the electrical system — is what this booklet is all about. Obviously, these are important subjects.

## A LOGICAL APPROACH TO ELECTRICAL DIAGNOSIS



If a customer comes in because his headlights aren't working, you can't just make a snap decision. That's not the *professional way*.



When you go to a doctor, for example, he tries to find out what's *really* wrong with you. He looks beyond the aches and pains you feel, to see what's *causing* the trouble. We call this, *diagnosis*.

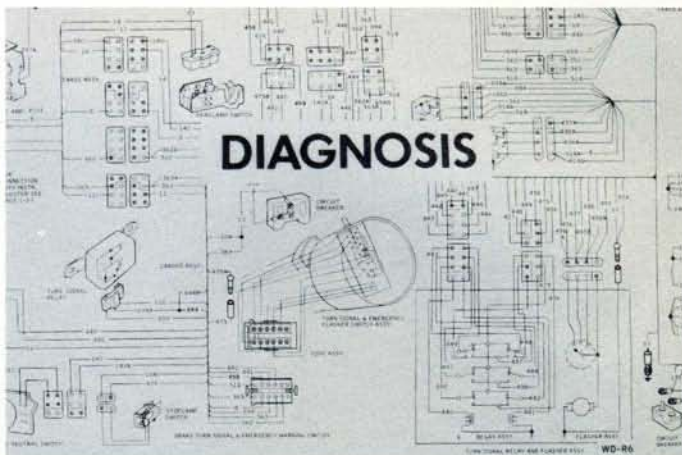

Troubleshooting an electrical system calls for diagnosis, too — *Your* diagnosis. *You're* the doctor. You must find out what's causing the trouble, and fix it.



**BUY IT NOW!**

**Click Here To Order**

unit may be the way may not. Snap professional.

