

# Colorized

# Mustang Wiring & Vacuum Diagrams

*(with Electrical Illustrations)*

**Free Bonus!**  
30-Minute Video  
Ford Training  
Course 13001, Vol 68 S7  
"How to Read Wiring  
Diagrams"  
Included!

**A consolidated collection of original Ford electrical & vacuum diagrams with illustrations**

## Color diagrams for:

- Automatic Transmission
- Convenience System
- Exterior and Interior Lights
- Heating and Air Conditioning
- Horns and Convertible Top
- Ignition, Starting and Charging
- Instrument Panel, Tachometer
- Radio, Stereo and Speakers
- Windshield Wiper and Washer
- Warning Lights and Console
- Warning Buzzer

...and much more!!

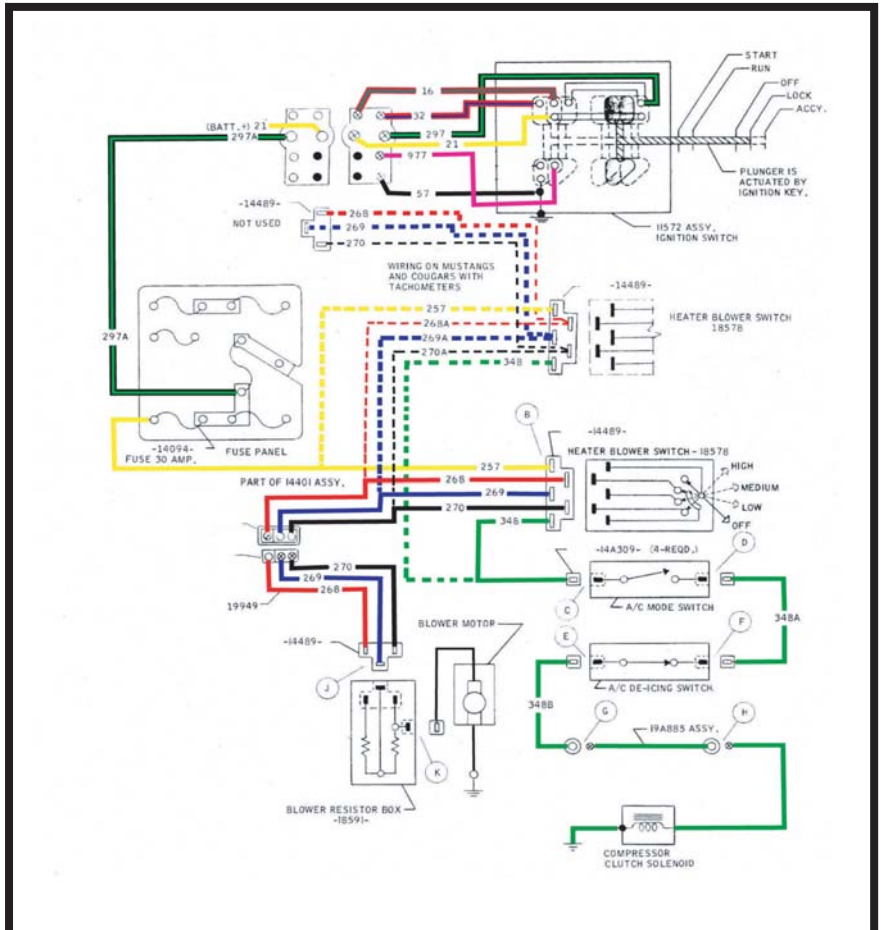

Example of colorized diagrams



Licensed and approved by  company

**100% SATISFACTION GUARANTEED**

**BUY IT NOW!**

**Click Here To Order**

PayPal, American Express, Discover, MasterCard, VISA

Copyright © 2008, Forel Publishing Company, LLC, Woodbridge, Virginia

All Rights Reserved. No part of this book may be used or reproduced in any manner whatsoever without written permission of Forel Publishing Company, LLC. For information write to Forel Publishing Company, LLC, 3999 Peregrine Ridge Ct., Woodbridge, VA 22192

1970 Colorized Mustang Wiring and Vacuum Diagrams  
(Extracted from Form 7098-70-3, Form FD-7795P-70, FP-7635B, and FD-7943-G)  
EAN: 978-1-60371-029-9  
ISBN: 1-60371-029-9

***Forel Publishing Company, LLC***  
***3999 Peregrine Ridge Ct.***  
***Woodbridge, VA 22192***  
***Email address: [webmaster@ForelPublishing.com](mailto:webmaster@ForelPublishing.com)***  
***Website: <http://www.ForelPublishing.com>***

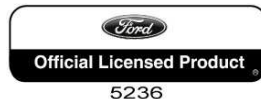

This publication contains material that is reproduced and distributed under a license from Ford Motor Company. No further reproduction or distribution of the Ford Motor Company material is allowed without the express written permission of Ford Motor Company.

---

## Note from the Editor

This product was compiled using several original Ford Motor Company publications. In some cases, there are slight differences between publications, so it is important to compare between diagrams, schematics, or illustrations. The contents of this product were extracted from: *1970 Car Shop Manual* (Form 7098-70-3, September 1969), *1965/1972 Ford Car Master Parts and Accessory Catalog* (Form FP-7635B, May 1975, and *1970 Wiring Diagrams* (Form FD-7795P-70) and *How to Read Wiring Diagrams* (FD-7943-G).

---

## Disclaimer

Although every effort was made to ensure the accuracy of this book, no representations or warranties of any kind are made concerning the accuracy, completeness or suitability of the information, either expressed or implied. As a result, the information contained within this book should be used as general information only. The author and Forel Publishing Company, LLC shall have neither liability nor responsibility to any person or entity with respect to any loss or damage caused, or alleged to be caused, directly or indirectly by the information contained in this book. Further, the publisher and author are not engaged in rendering legal or other professional services. If legal, mechanical, electrical, or other expert assistance is required, the services of a competent professional should be sought.





## ATTENTION



### Please Read This

It is important to note that differences exist between similar or like wiring diagrams even though they are original Ford publications. It is for this reason there may be multiple versions of what appears to be the same wiring diagram. If your vehicle has a color coded wire that does not match a diagram you should consult the other diagrams contained in the manual for a possible match.

#### Example of differences

385, 140,	25	BLACK-ORANGE
	26	BLACK-RED
	44	BLUE
	296	RED
	297	YELLOW-GREEN
	365	RED-WHITE
	478	GRAY
	511	GREEN
	784	BROWN

In the wiring diagrams from the Ford publication Form 7795P-70F, the Mustang Exterior Lights Wiring Color Code shows:  
**297 Yellow-Green**

102	GREEN-RED
215	YELLOW-BLACK
297	BLACK-GREEN
365	BLUE-RED
627	GREEN-WHITE

However, in the Wiring Color Code section of the Mustang Warning Lights it has:  
**297 Black-Green**

---

296	RED
297	BLUE-GREEN STRIPE
297A	SLICE
	GROUND

Then, in the Wiring Color Code section of the Automatic Transmission, it has:  
**297 Blue-Green Stripe**

The color coded wiring diagrams are provided for illustration purposes only. Only the wire number should be used for the identification of the wire itself. The color coding of the wires in the product may not match the actual colors of the wires in the vehicle. In some cases, the colors have been altered to provide a visual contrast (i.e. the color white has been shaded to make it more visible). As stated in the paragraph above, there are some variation and/or differences between the original Ford wiring diagrams. If your vehicle has a color coded wire that does not match a diagram you should consult the other diagrams contained in the manual for a possible match.

**Disclaimer:** Although every effort was made to ensure the accuracy of this book, no representations or warranties of any kind are made concerning the accuracy, completeness or suitability of the information, either expressed or implied. As a result, the information contained within this book should be used as general information only. The author and Forel Publishing Company, LLC shall have neither liability nor responsibility to any person or entity with respect to any loss or damage caused, or alleged to be caused, directly or indirectly by the information contained in this book. Further, the publisher and author are not engaged in rendering legal or other professional services. If legal, mechanical, electrical, or other expert assistance is required, the services of a competent professional should be sought.

**100% SATISFACTION GUARANTEED**

**BUY IT NOW!**

**Click Here To Order**

## 1970 Color Wiring Codes

Number	Wire Description	Source
2	WHITE-BLUE STRIPE	Form 7795P-70F
3	GREEN-WHITE STRIPE	Form 7795P-70F
4	WHITE-BLACK STRIPE	Form 7795P-70F
5	ORANGE-BLUE STRIPE	Form 7795P-70F
8	ORANGE-YELLOW STRIPE	Form 7795P-70F
9	GREEN-ORANGE STRIPE	Form 7795P-70F
10	GREEN-RED STRIPE	Form 7795P-70F
<b>11</b>	<b>GREEN-YELLOW STRIPE</b>	Form 7795P-70F
<b>11</b>	<b>BLACK-YELLOW STRIPE</b>	Form 7795P-70F
11A	BLACK-YELLOW STRIPE	FORM 7795P-69
12	GREEN-BLACK STRIPE	Form 7795P-70F
13	RED-BLACK STRIPE	Form 7795P-70F
14	BLACK	Form 7795P-70F
15	RED-YELLOW STRIPE	Form 7795P-70F
<b>16</b>	<b>RED-GREEN STRIPE</b>	<b>Form 7795P-70F</b>
<b>16</b>	<b>PINK</b>	<b>Form 7795P-70F</b>
16A	PINK	Form 7795P-70F
19	BLUE-RED STRIPE	Form 7795P-70F
19A	BLUE-RED STRIPE	Form 7795P-70F
19B	BLUE-RED STRIPE	Form 7795P-70F
19C	BLUE-RED STRIPE	Form 7795P-70F
19D	BLUE-RED STRIPE	Form 7795P-70F
19E	BLUE-RED STRIPE	Form 7795P-70F
21	YELLOW	Form 7795P-70F
22	BLUE-BLACK STRIPE	Form 7795P-70F
25	BLACK-ORANGE STRIPE	Form 7795P-70F
26	BLACK-RED STRIPE	Form 7795P-70F
26A	BLACK-RED STRIPE	Form 7795P-70F
28	BLACK	Form 7795P-70F
29	YELLOW-WHITE STRIPE	Form 7795P-70F
<b>30</b>	<b>BLACK-GREEN STRIPE</b>	<b>Form 7795P-70F</b>
<b>30</b>	<b>VIOLET</b>	<b>Form 7795P-70F</b>
30A	VIOLET (Resistance Wire)	Form 7795P-70F
31	WHITE-RED STRIPE	Form 7795P-70F
32	RED-BLUE STRIPE	Form 7795P-70F
32A	RED-BLUE STRIPE	Form 7795P-70F
32B	Not Listed	Form 7795P-70F
34	GREEN-BLACK STRIPE	Form 7795P-70F
35	ORANGE	Form 7795P-70F
	<b>BLACK-YELLOW STRIPE</b>	<b>Form 7795P-70F</b>
		<b>Form 7795P-70F</b>

Number	Wire Description	Source
37A	BLACK-YELLOW STRIPE	Form 7795P-70F
38	BLACK	Form 7795P-70F
38A	BLACK	Form 7795P-70F
38B	BLACK	Form 7795P-70F
39	RED-WHITE STRIPE	Form 7795P-70F
40	BLUE-WHITE STRIPE	Form 7795P-70F
44	BLUE	Form 7795P-70F
48	Not Listed	Form 7795P-70F
49	WHITE-BLUE STRIPE	Form 7795P-70F
50	GREEN-WHITE STRIPE	Form 7795P-70F
53A	BLACK-BLUE STRIPE	Form 7795P-70F
53B	BLACK-BLUE STRIPE	Form 7795P-70F
53C	BLACK-BLUE STRIPE	Form 7795P-70F
53D	BLACK-BLUE STRIPE	Form 7795P-70F
53E	BLACK-BLUE STRIPE	Form 7795P-70F
53F	BLACK-BLUE STRIPE	Form 7795P-70F
54	GREEN-YELLOW STRIPE	Form 7795P-70F
54A	GREEN-YELLOW STRIPE	Form 7795P-70F
54B	GREEN-YELLOW STRIPE	Form 7795P-70F
54C	GREEN-YELLOW STRIPE	Form 7795P-70F
54D	GREEN-YELLOW STRIPE	Form 7795P-70F
56	BLUE	Form 7795P-70F
57	BLACK	Form 7795P-70F
57A	BLACK	Form 7795P-70F
57B	BLACK	Form 7795P-70F
57C	BLACK	Form 7795P-70F
57H	BLACK	Form 7795P-70F
58	WHITE	Form 7795P-70F
63	RED	Form 7795P-70F
122	YELLOW	Form 7795P-70F
123	RED	Form 7795P-70F
137	YELLOW-BLACK STRIPE	Form 7795P-70F
140	BLACK-RED STRIPE	Form 7795P-70F
140A	BLACK-RED STRIPE	Form 7795P-70F
<b>152</b>	<b>YELLOW</b>	<b>Form 7795P-70F</b>
<b>152</b>	<b>GREEN-BLACK STRIPE</b>	<b>Form 7795P-70F</b>
159	Not Listed	Form 7795P-70F
161	GREEN	Form 7795P-70F
162	GREEN-RED STRIPE	Form 7795P-70F
175	BLACK	Form 7795P-70F
215	YELLOW-BLACK STRIPE	Form 7795P-70F

**100% SATISFACTION GUARANTEED**

**BUY IT NOW!**

**Click Here To Order**

PayPal American Express Discover MasterCard VISA

Number	Wire Description	Source
257	YELLOW	Form 7795P-70F
262	BROWN	Form 7795P-70F
268	RED	Form 7795P-70F
269	BLUE	Form 7795P-70F
270	BLACK	Form 7795P-70F
296	RED	Form 7795P-70F
<b>297</b>	<b>BLACK-GREEN STRIPE</b>	<b>Form 7795P-70F</b>
<b>297</b>	<b>BLUE-GREEN STRIPE</b>	<b>Form 7795P-70F</b>
<b>297</b>	<b>YELLOW-GREEN STRIPE</b>	<b>Form 7795P-70F</b>
297A	BLACK-GREEN STRIPE	Form 7795P-70F
297A	BLUE-GREEN STRIPE	Form 7795P-70F
348A	GREEN	Form 7795P-70F
348B	GREEN	Form 7795P-70F
365	BLUE-RED STRIPE	Form 7795P-70F
366	Not Listed	Form 7795P-70F
367	GREEN-WHITE STRIPE	Form 7795P-70F
383	RED-WHITE STRIPE	Form 7795P-70F
450	Not Listed	Form 7795P-70F
460	YELLOW	Form 7795P-70F
469	GREEN	Form 7795P-70F
478	GRAY	Form 7795P-70F
482	BLUE-YELLOW STRIPE	Form 7795P-70F
482A	BLUE-YELLOW STRIPE	Form 7795P-70F
490	BLACK-RED STRIPE	Form 7795P-70F
511	GREEN	Form 7795P-70F
520	VIOLET	Form 7795P-70F
627	BLACK-VIOLET STRIPE	Form 7795P-70F
640	RED-YELLOW STRIPE	Form 7795P-70F
643	YELLOW-BLACK STRIPE	Form 7795P-70F
654	YELLOW	Form 7795P-70F
655	RED	Form 7795P-70F
70	GRAY	Form 7795P-70F
708	BLACK	Form 7795P-70F
709	BLACK-GREEN STRIPE	Form 7795P-70F
763	ORANGE-WHITE STRIPE	Form 7795P-70F
806	WHITE	Form 7795P-70F
807	ORANGE	Form 7795P-70F
904	VIOLET	Form 7795P-70F
904	VIOLET (Resistance Wire)	Form 7795P-70F
	GREEN-RED STRIPE	Form 7795P-70F
		Form 7795P-70F

Number	Wire Description	Source
951	GREEN	Form 7795P-70F
977	VIOLET	Form 7795P-70F
984	BROWN	Form 7795P-70F

Note – wire color codes highlighted in **RED** designate a difference either between the original Ford wiring publications or within the same publication. Those highlighted have the same wire number but have different color codes.

**100% SATISFACTION GUARANTEED**

**BUY IT NOW!**

**Click Here To Order**

PayPal American Express Discover Novus MasterCard VISA

Source Document  
Ford Publication Form 7795P-70

# 1970

COURSE 13003 and 1703

# WIRING and VACUUM DIAGRAMS



**SERVICE  
TRAINING**

FORM 77



**BUY IT NOW!**

**Click Here To Order**



# HOW TO USE THE WIRING DIAGRAMS

THE INDEX PAGE IS THE FIRST PAGE IN EACH SECTION. EACH ELECTRICAL SCHEMATIC WILL HAVE A NOTATION AS TO THE SOURCE OF POWER FOR THAT SYSTEM. ALL WIRES WILL BE SHOWN AS SINGLE LINES TO PROVIDE A CLEAR UNDERSTANDING OF THE DIAGRAMS. TO TRACE A CIRCUIT, IT IS RECOMMENDED TO START AT THE GROUND CIRCUIT OF THE INOPERATIVE COMPONENT, TRACE IT THROUGH ALL CONNECTORS TO THE SOURCE, AND NOTE THE POSSIBLE TROUBLE AREAS AND POINTS OF MOST CONVENIENT ACCESS. WIRE CONNECTORS WILL BE IDENTIFIED ON THE SCHEMATIC AND THE PICTORIAL DRAWINGS, THIS WILL SHOW THE TECHNICIAN THE LOCATION OF THE CONNECTORS. MOST WIRE CONNECTORS ARE SHOWN IN OPEN BOOK FASHION. A WIRE ON THE TOP RIGHT OF A CONNECTOR (OPEN SIDE BY SIDE) WILL BE ON THE TOP LEFT SIDE OF THE OTHER HALF OF THE CONNECTOR. SEE FIGURE 1 (WIRE #140 TO #140A, ETC.).

WIRE DISCONNECTS AND CONNECTORS WILL ALL BE BLACK UNLESS A COLOR CODE IS NOTED ON THE DIAGRAM. THE COLORED DISCONNECTS AND CONNECTORS ARE TO AID THE TECHNICIAN IN FINDING THE PROPER CIRCUIT TO BE TESTED OR TRACED. THE ELECTRICAL SYMBOLS AND THEIR MEANINGS ARE NOTED ON EACH DIVIDER PAGE TO PROVIDE A CLEARER UNDERSTANDING OF THE DIAGRAMS. PICTORIAL DRAWINGS OF A COMPONENT WILL INCLUDE THE SPECIFIC LOCATION OF SOME COMPONENTS IN CASES WHERE IT IS DIFFICULT TO DETERMINE IF THE COMPONENT IS UNDER THE INSTRUMENT PANEL OR IN THE ENGINE COMPARTMENT.

RELAYS AND SWITCHES ARE SHOWN IN THE "SYSTEM OFF" POSITION. IF A VEHICLE SPECIFIC WIRE COLOR IN A CONNECTOR DOES NOT MATCH THE DIAGRAM SHOWN, IT CAN USUALLY BE IDENTIFIED BY COMPARING THE OTHER COLORS SHOWN AT THE WIRE CONNECTORS. SPECIFIC WIRE COLOR DEVIATIONS IN THE MANUFACTURING OF A WIRE HARNESS ARE USUALLY FOR A SHORT DURATION.

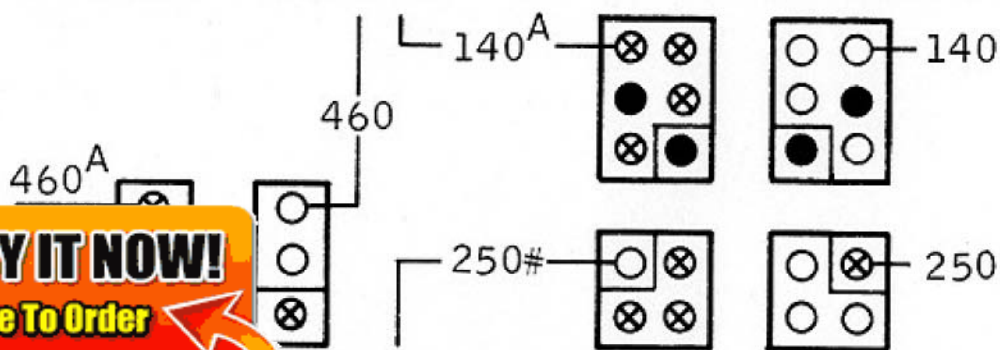
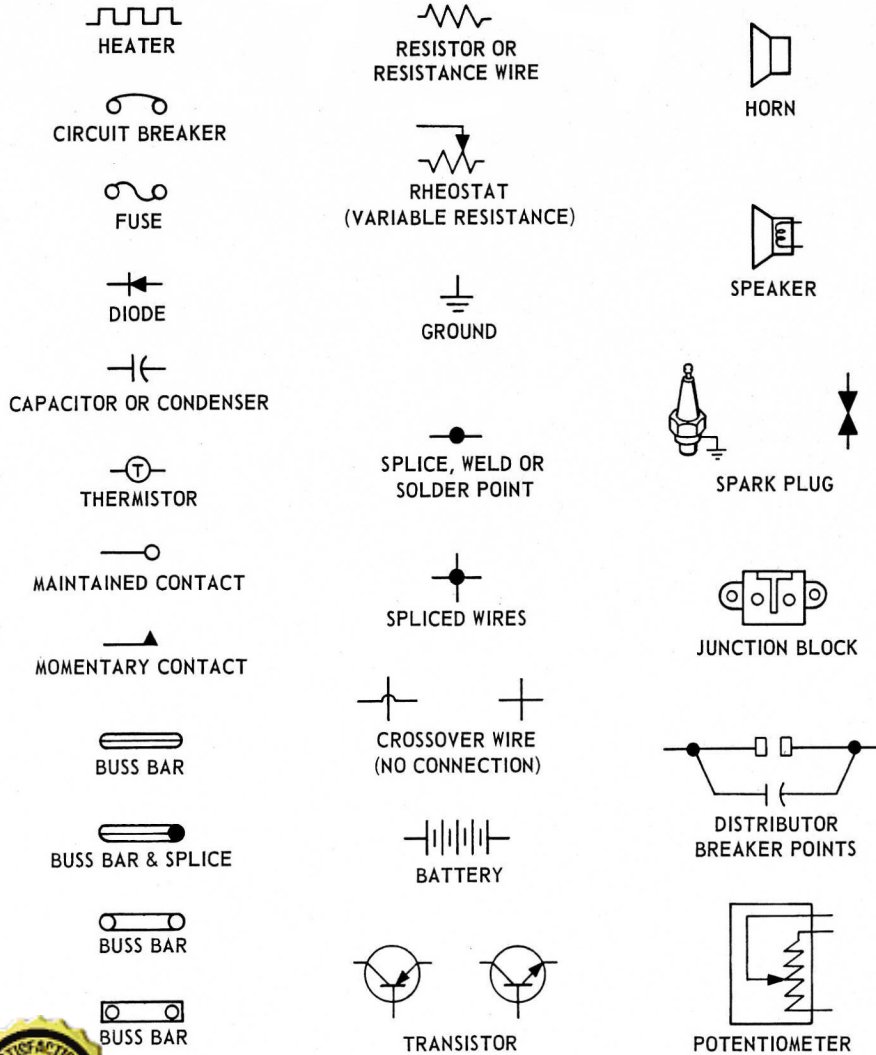

Figure 1

**100% SATISFACTION GUARANTEED**  
**BUY IT NOW!**  
**Click Here To Order**

PayPal | American Express | Discover | MasterCard | VISA

## CIRCUIT SYMBOLS



## SWITCHES

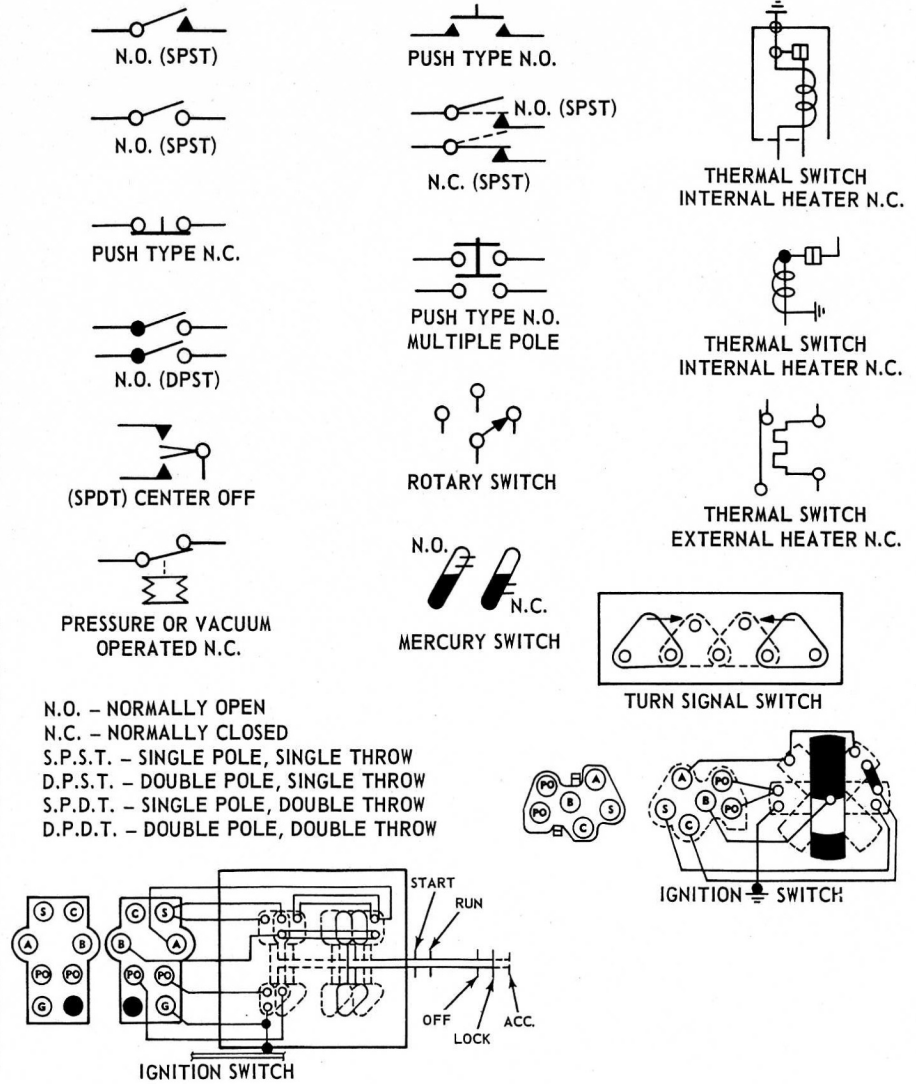

**100% SATISFACTION GUARANTEED**

**BUY IT NOW!**

**Click Here To Order**



## RELAYS

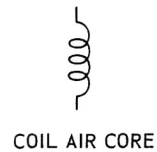
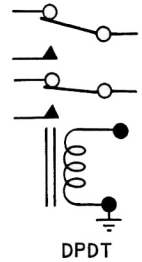
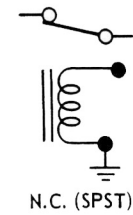
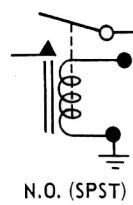
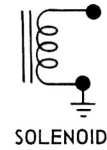
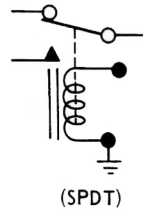
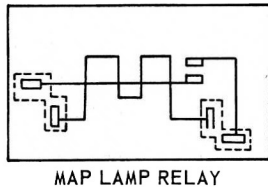
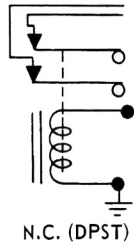
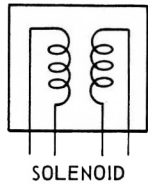
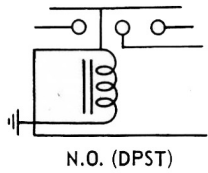

## LAMPS

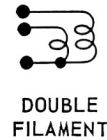
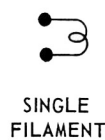

## CONNECTORS

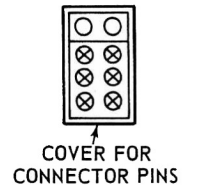
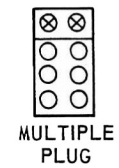
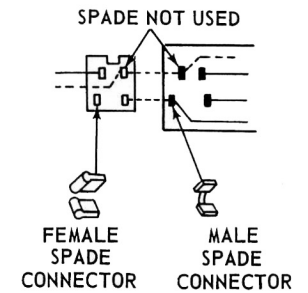
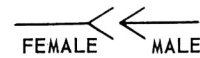
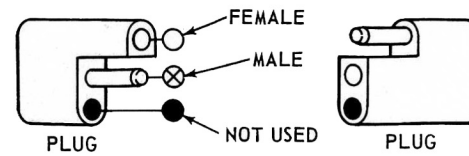

## MOTORS

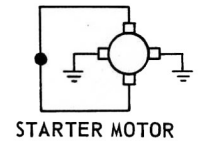
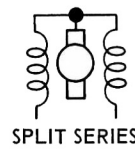
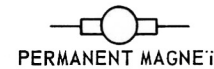
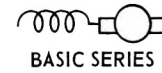

## GAUGES

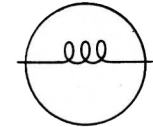
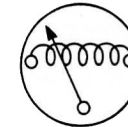
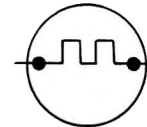

N.O. - NORMALLY OPEN  
N.C. - NORMALLY CLOSED  
S.P.S.T. - SINGLE POLE, SINGLE THROW  
D.P.S.T. - DOUBLE POLE, SINGLE THROW  
S.P.D.T. - SINGLE POLE, DOUBLE THROW  
D.P.D.T. - DOUBLE POLE, DOUBLE THROW

**100% SATISFACTION GUARANTEED**

**BUY IT NOW!**

**Click Here To Order**

# 1970 MUSTANG AND COUGAR ELECTRICAL DRAWINGS

## SECTION 2 INDEX

	PICTORIAL	SCHEMATIC		PICTORIAL	SCHEMATIC		PICTORIAL	SCHEMATIC
<b>AIR CONDITIONER</b>								
Mustang & Cougar	2-E5	2-E28						
<b>BRAKE LIGHTS</b>								
Mustang	2-E2	2-E25						
Cougar	2-E3	2-E21						
<b>CHARGING</b>								
Mustang	2-E2	2-E10 & 11						
Cougar	2-E3	2-E10 & 11						
Cougar XR7	2-E3	2-E12 & 13						
<b>CIGAR LIGHTER</b>								
Mustang	2-E2	2-E34						
Cougar	2-E3	2-E22 & 34						
<b>CIRCUIT PROTECTION</b>								
Mustang & Cougar	2-E37 & 38	2-E37						
<b>CLOCK</b>								
Mustang	2-E5	2-E22						
Cougar	2-E14	2-E22 & 23						
<b>CONVENIENCE SYSTEMS</b>								
Cougar	2-E9	2-E15						
Cougar XR7 (Prove Out)		2-E12 & 15						
<b>CONVERTIBLE TOP</b>								
Mustang & Cougar	2-E2 & 3	2-E19 & 25						
<b>DEFOGGER</b>								
Cougar		2-E29						
<b>EXTERIOR LIGHTS</b>								
	2-E2	2-E16 & 17						
	2-E3	2-E18 & 20						
<b>GAUGES</b>								
Mustang	2-E5	2-E11						
Cougar	2-E5	2-E12 & 13						
Cougar XR7	2-E5	2-E14						
<b>HEADLAMP "ON" WARNING BUZZER</b>								
		2-E36						
<b>HEATER AND DEFROSTER</b>								
Mustang & Cougar	2-E2 & 3	2-E28						
<b>HORNS</b>								
Mustang & Cougar	2-E2 & 3	2-E19						
<b>KEY WARNING BUZZER</b>								
		2-E35						
<b>IGNITION</b>								
Mustang	2-E2	2-E10 & 11						
Cougar XR7	2-E3	2-E12 & 13						
Cougar	2-E3	2-E14						
<b>INSTRUMENT PANEL</b>								
Mustang		2-E6						
Cougar		2-E7, 2-E22 & 23						
Cougar XR7		2-E8			2-E23			
<b>INTERIOR LIGHTS</b>								
Mustang	2-E2	2-E22						
Cougar	2-E3	2-E22						
Cougar XR7	2-E3	2-E25						
<b>NEUTRAL SWITCH</b>								
Mustang		2-E33						
Cougar		2-E10						
<b>PARKING BRAKE WARNING LIGHT</b>								
		2-E9 & 15						
<b>POWER WINDOWS</b>								
Cougar	2-E4	2-E32						
<b>RADIO AND STEREO TAPE</b>								
Mustang & Cougar	2-E4 & 5	2-E30 & 31						
<b>SEAT BACK LATCH</b>								
		2-E9						
<b>SEAT BELT REMINDER LIGHTS</b>								
Mustang & Cougar	2-E2 & 3	2-E34						
<b>STARTING</b>								
Mustang	2-E2	2-E11						
Cougar	2-E3	2-E12						
Cougar XR-7	2-E3	2-E13						
<b>TACHOMETER</b>								
Mustang & Cougar	2-E5	2-E11						
<b>TURN SIGNALS</b>								
Mustang	2-E2	2-E16 & 17						
Cougar	2-E3	2-E20 & 21						
<b>VACUUM SYSTEMS</b>								
		2-E39						
<b>WINDSHIELD WIPERS AND WASHERS</b>								
Mustang & Cougar	2-E2 & 3	2-E26						
Mustang & Cougar (Intermittent)		2-E27						

**100% SATISFACTION GUARANTEED**

**BUY IT NOW!**

**Click Here To Order**

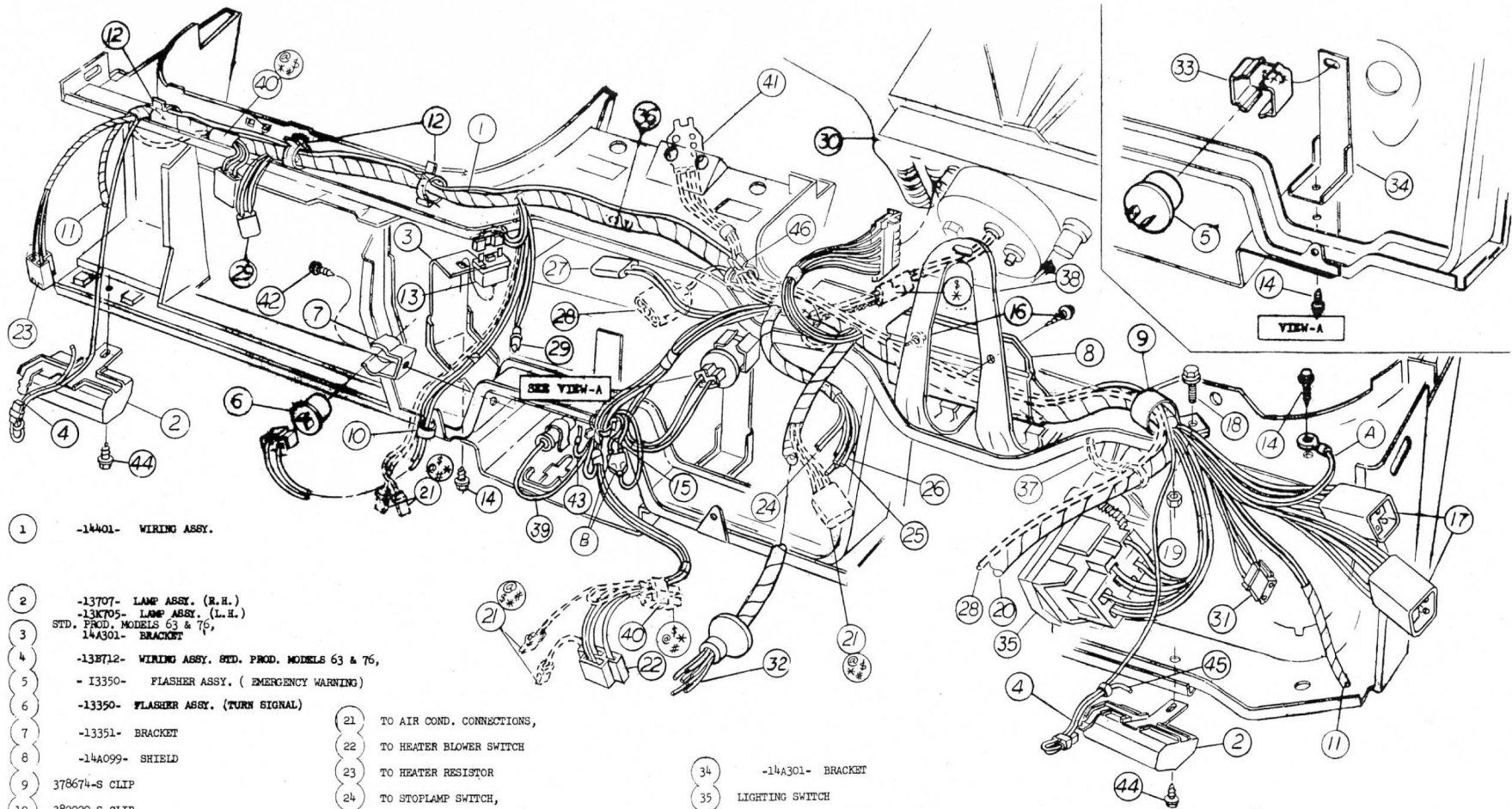

1 -14401- WIRING ASSY.

2 -13707- LAMP ASSY. (R.H.)  
 -13K705- LAMP ASSY. (L.H.)  
 STD. PROD. MODELS 63 & 76,  
 14A301- BRACKET

3 -13B712- WIRING ASSY. STD. PROD. MODELS 63 & 76,  
 - 13350- FLASHER ASSY. ( EMERGENCY WARNING)

4 -13350- FLASHER ASSY. (TURN SIGNAL)

5 -13351- BRACKET

6 -14A099- SHIELD

7 378674-S CLIP

8 382929-S CLIP

9 TO JAMB SWITCH

10 383207-S CLIP (3-REAR.)

11 -13150- BUZZER ASSY.

12 55907-S36 SCREW (3-REAR.)

13 383477-S CLIP

14 40927-S2 SCREW (2-REQD.)

15 TO 14405 WIRING ASSY.,

16 56303-S4 BOLT

17 34659-S2 NUT

18 14401 ASSY. TO FUSE PANEL

21 TO AIR COND. CONNECTIONS,

22 TO HEATER BLOWER SWITCH

23 TO HEATER RESISTOR

24 TO STOPLAMP SWITCH,

25 TO WIPER SWITCH & CIGAR LIGHTER

26 TO IGNITION & 7200 ASSY. CONNECTIONS

27 TO RADIO RECEIVER,

28 PART OF 14A318 ASSY.

29 TO CLOCK & MAP LAMP,  
 TO 13B712 ASSY.

30 INSTRUMENT CLUSTER

31 TO THERMO SWITCH

32 ENGINE COMPT. WIRING,

33 -13351- BRACKET

34 -14A301- BRACKET

35 LIGHTING SWITCH

36 POSITION LOCATOR IN HOLE PROVIDED

37 351053 STRAP

38 BRACE ASSY. BRAKE PEDAL SUPPORT

39 -13A726- LAMP ASSY. (ASH RECP.)

40 ESB-M3071-A TAPE, USE THREE (.75 x 6.00)  
 PIECES WHEN A/C IS NOT SPECIFIED

41 TO GRILLE LAMPS

42 55906-S36 SCREW

43 FOR HEATER CONTROL LAMP,

44 55907-S36 SCREW (2-REAR.)

45

46 383312-S CLIP

A 57 BLACK  
 B RED INSULATOR

**100% SATISFACTION GUARANTEED**

**BUY IT NOW!**

**Click Here To Order**

## 1970 MUSTANG INSTRUMENT PANEL

2-E6  
 9-1-69

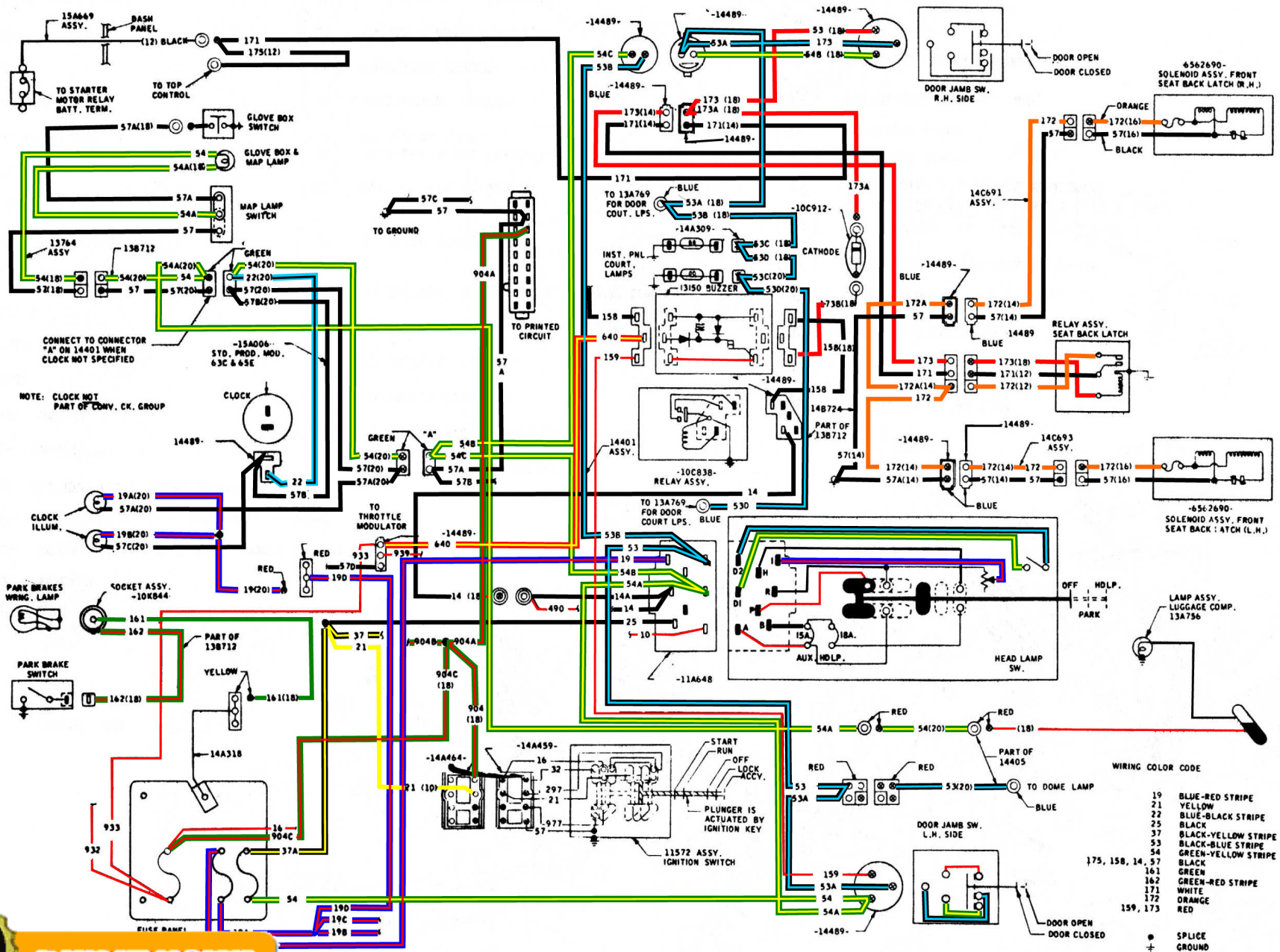

**WIRING COLOR CODE**

19	BLUE-RED STRIPE
21	YELLOW
22	BLUE-BLACK STRIPE
25	BLACK
37	BLACK-YELLOW STRIPE
53	BLACK-BLUE STRIPE
54	GREEN-YELLOW STRIPE
161	BLACK
162	GREEN-RED STRIPE
171	WHITE
172	ORANGE
159, 173	RED

● SPLICE  
 ⊕ GROUND

**100% SATISFACTION GUARANTEED**

**BUY IT NOW!**

**Click Here To Order**

# 1970 MUSTANG CONVENIENCE SYSTEM

2-E9  
9-1-69

Source Document  
Ford Publication Form 7795P-70

# 1970

COURSE 13003 and 1703

# WIRING and VACUUM DIAGRAMS



**SERVICE  
TRAINING**

FORM 77



**BUY IT NOW!**

**Click Here To Order**



# HOW TO USE THE VACUUM DIAGRAMS

IF IT IS A FORD CAR LINE VACUUM SYSTEM, THE TECHNICIAN WILL FIND A PAGE FOR THE TOTAL SCHEMATIC SYSTEM AS WELL AS A LISTING FOR A SCHEMATIC AND PICTORIAL OF EACH SUBSYSTEM ON EACH SECTION INDEX PAGE. IT IS RECOMMENDED THAT THE TECHNICIAN FIRST TURN TO THE TOTAL SYSTEMS SCHEMATIC TO DETERMINE IF THERE ARE ANY BRANCH SYSTEMS OPERATING FROM THE SAME SOURCE. THIS WILL ASSIST IN LOCATING SYSTEM TROUBLES. HE WILL THEN BE ABLE TO TURN TO A PAGE TO FIND DETAILED INFORMATION ON A PARTICULAR SYSTEM. IN TRACING VACUUM SYSTEMS, IT IS RECOMMENDED THAT A CIRCUIT BE TRACED FROM ITS CONTROL UNIT TO ITS SOURCE OF VACUUM, AND THEN FROM THE CONTROL UNIT TO THE OPERATING UNIT, NOTING POINTS OF POSSIBLE MALFUNCTION AND ACCESSIBILITY.

THE VACUUM SYMBOLS AND THEIR MEANINGS ARE NOTED ON EACH DIVIDER PAGE TO PROVIDE A CLEAR UNDERSTANDING OF THE DIAGRAMS.

## VACUUM

### CIRCUIT SYMBOLS

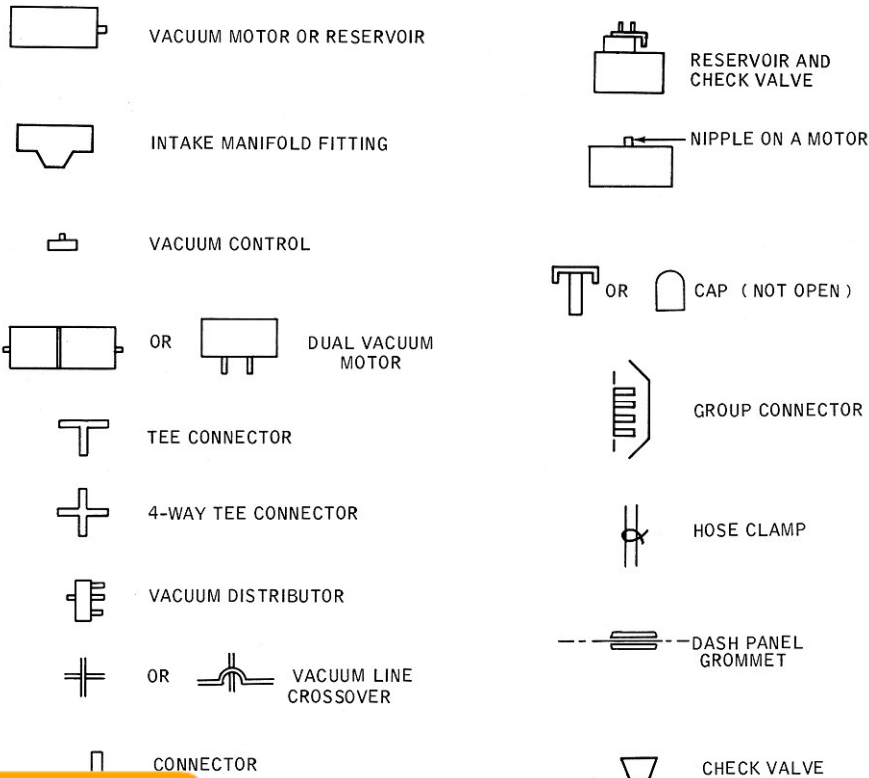

**BUY IT NOW!**

**Click Here To Order**



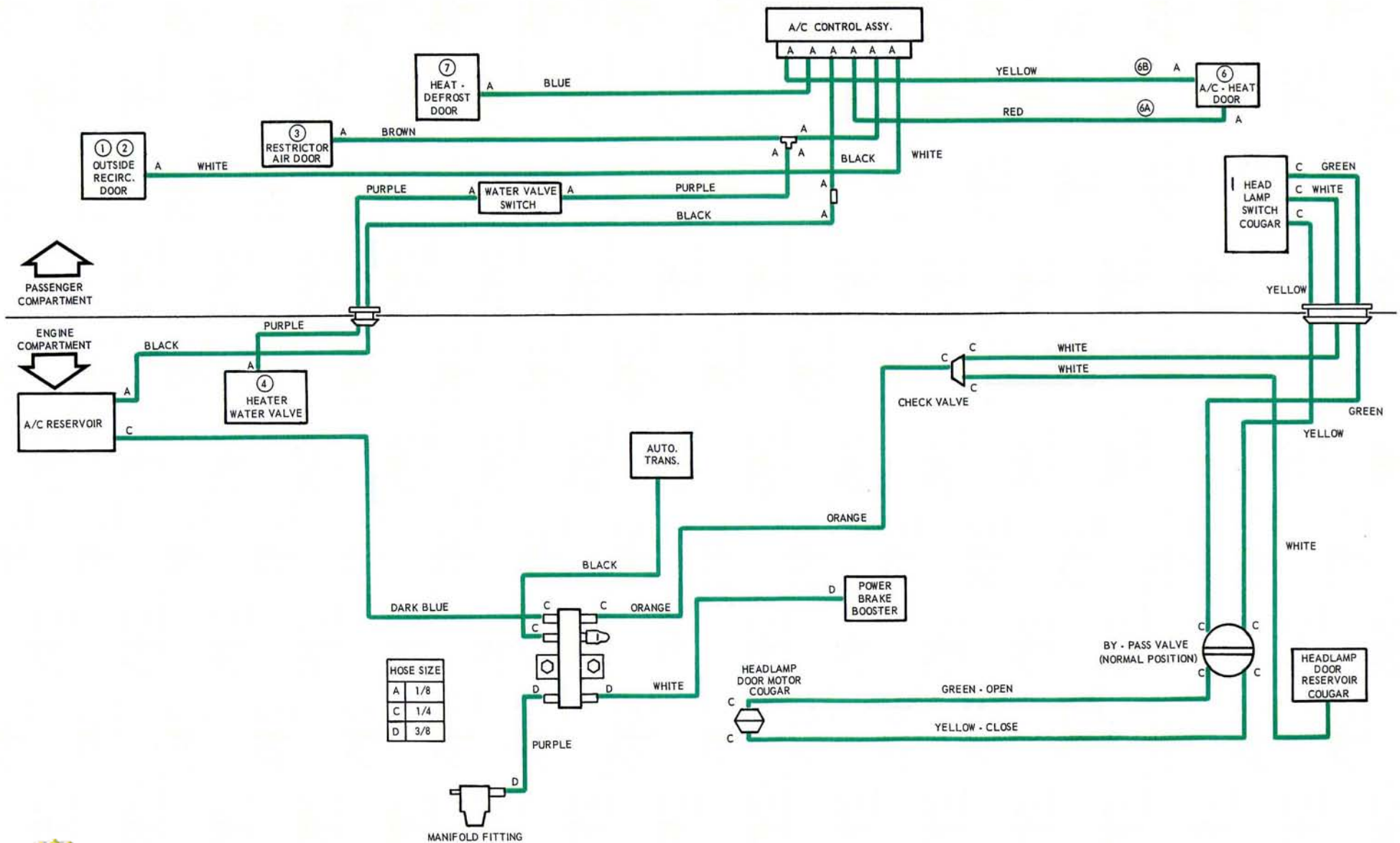

**100% SATISFACTION GUARANTEED**

**BUY IT NOW!**

**Click Here To Order**

**1970 MUSTANG AND COUGAR TOTAL VACUUM SCHEMATIC**

# 1970 CAR SHOP MANUAL

Source Document  
Ford Publication Form 7098-70-3

VOLUME THREE  
ELECTRICAL

METEOR

MAVERICK

FALCON

FAIRLANE

MUSTANG

FORD

THUNDERBIRD

MONTEGO

COUGAR

MERCURY

LINCOLN  
CONTINENTAL

CONTINENTAL  
MARK III



**BUY IT NOW!**

**Click Here To Order**



INDEX and IDENTIFICATION .....	10
WHEELS and TIRES .....	11
BRAKES .....	12
STEERING .....	13
SUSPENSION .....	14
DRIVING SHAFT .....	15
MANUAL TRANSMISSION and CLUTCH (TRANSFER CASE and AUXILIARY TRANSMISSION) .....	16
AUTOMATIC TRANSMISSION .....	17

**VOLUME ONE**

INDEX and IDENTIFICATION .....	20
ENGINE .....	21
IGNITION SYSTEM .....	22
FUEL SYSTEM .....	23
COOLING SYSTEM .....	24
EXHAUST SYSTEM .....	25
STARTING SYSTEM .....	26

**VOLUME TWO**

**VOLUME  
THREE  
ELECTRICAL**

INDEX and IDENTIFICATION .....	40
SEATS .....	41
WINDOWS (MANUAL and POWER) .....	42
DOORS, HOODS, LUGGAGE COMPARTMENT DOORS, TAILGATES .....	43
WINDSHIELD, BACK WINDOW GLASS .....	44
CONVERTIBLE TOPS, SUN ROOF PANEL .....	45
ROOF, OUTSIDE COVER, WOOD GRAIN TRANSFER, VINYL ROOFS, PAINT .....	46
INTERIOR TRIM .....	47
BODY SHELL, EXTERIOR TRIM, FRAMES, UNDERBODY .....	48

**VOLUME FOUR**

INDEX and IDENTIFICATION .....	50
PRE-DELIVERY SEQUENCE GUIDE .....	51
MAINTENANCE SCHEDULE .....	52
LUBRICATION .....	53
PRE-DELIVERY MAINTENANCE PROCEDURES .....	54

**VOLUME FIVE**

**GROUP INDEX**

INDEX and IDENTIFICATION **30**

CHARGING SYSTEM **31**

EXTERIOR LIGHTS,  
HEADLIGHT DIMMER,  
TURN SIGNALS, HORNS **32**

INTERIOR LIGHTS,  
INSTRUMENTS, INSTRUMENT  
PANEL CONTROLS and CLOCK, **33**

VENTILATING, HEATING,  
AIR CONDITIONING **34**

AUXILIARY EQUIPMENT:  
RADIO, STEREO,  
WINDSHIELD WIPER and  
WASHER, LIGHTERS, ASH  
RECEPTACLES, MIRRORS, ETC. **35**

WIRING, CIRCUIT PROTECTION,  
BULB CHARTS **36**

VACUUM SYSTEMS **37**

SPEED CONTROL,  
ANTI-SKID CONTROL **38**



**BUY IT NOW!**

Click Here To Order



ICATIONS

FIRST PRINTING - SEPTEMBER, 1969  
© 1969 FORD MOTOR COMPANY, DEARBORN, MICHIGAN

## FOREWORD

*This manual is divided into five volumes: 1 – Chassis, 2 – Engine, 3 – Electrical, 4 – Body, 5 – Maintenance and Lubrication. These volumes should provide Service Technicians with complete information covering normal service repairs on all 1970 model passenger cars built by Ford Motor Company in the U.S. and Canada. As changes in the product occur, this information will be updated by Technical Service Bulletins. When issued, TSB information always supersedes that published here.*

*Within each volume, information is grouped by system or component plus "General Service" parts which contain information which is common to several similar components.*

*The table of contents on the first page of each volume indicates the general content of the book and provides a handy tab locator to make it easy to find the first page of each "group." That page will contain an index to "parts" and the first page of each "part" contains a detailed index which gives page location for each service operation covered. Page numbers are consecutive in each "part."*

*Those who have previously used Ford Shop Manuals will find a major change this year in the division of information into "groups" and "parts." To make reference easier, information has been broken down into smaller units so that essentially there is now one "part" for each component or system. Group numbers have been changed so that the first digit of the number indicates the volume in which the group may be found.*

*Example:*

36 – 05 – 13  
Volume 3 – Group 6 – Part 5 – Page 13

*We hope that this change in indexing will make it easier and quicker to locate desired information within these manuals.*

*The descriptions and specifications in this manual were in effect at the time this manual was approved for printing. Ford Motor Company reserves the right to discontinue models at any time, or change specifications or design, without notice and without incurring obligation.*

 **SERVICE PUBLICATIONS**



# Identification

**GROUP  
30**



W 1002-B

MANUFACTURED BY 100001  
 FORD MOTOR COMPANY

09/69 THIS VEHICLE CONFORMS  
 TO ALL APPLICABLE FEDERAL  
 MOTOR VEHICLE SAFETY STANDARDS  
 IN EFFECT ON DATE OF  
 MANUFACTURE SHOWN ABOVE.

NOTE:  
WORDING  
WILL VARY  
WITH  
VEHICLE  
LINE

VEH. IDENT. NO.		BODY	COL.
0E51N100001		54E	M
TRIM	AXLE	TRNS.	DSO
1B	4	W	33

NOT FOR TITLE OR REGISTRATION

MADE IN U.S.A.

① CONSECUTIVE UNIT NO.

② BODY SERIAL CODE

③ MODEL YEAR CODE

④ ASSEMBLY PLANT CODE

⑤ ENGINE CODE

⑥ TRIM CODE

⑦ REAR AXLE CODE

⑧ COLOR CODE

⑨ BODY TYPE CODE

⑩ DISTRICT SPEC EQUIP CODE

⑪ TRANSMISSION CODE

W 1009 A

Warranty identification of the vehicle. The first number indicates the model year. The letter following the model year number indicates the manufacturing assembly plant. The next two numbers designate the Body Serial Code followed by a letter expressing the Engine Code. The last six digits of the Vehicle Identification Number indicate the Consecutive Unit Number.

The remaining information on the V.C. Label consists of pertinent vehicle identification codes. The BODY code is two numerals and a letter identifying the body style. The COL (color) code is a number or letter (or both) indicating the exterior paint color code. The TRIM code consists of a number-letter combination designating the interior trim. The Axle code is a number or letter indicating the rear axle ratio and standard or locking type axles. The TRNS. code is a number or letter indicating the type of transmission, numerals for manual and letters for automatic or semi-automatic. The DSO code consisting of two numbers designates the district in which the car was ordered and may appear in conjunction with a Domestic Special Order or Foreign Special Order number when applicable. Ford of Canada DSO codes consist of a letter and a number except for export codes which are designated by two numbers.

### MODEL YEAR CODE

The number 0 designates 1970.

### ASSEMBLY PLANT CODES

Code Letter	
A.....	Atlanta
B.....	Oakville (Canada)
C.....	Ontario Truck
D.....	Dallas
E.....	Mahwah
F.....	Dearborn
G.....	Chicago
H.....	Lorain
J.....	Los Angeles
K.....	Kansas City
L.....	Michigan Truck
N.....	Norfolk
P.....	Twin Cities
R.....	San Jose
S.....	Allen Park
T.....	Metuchen
U.....	Louisville
V.....	Kentucky Truck
W.....	Wayne
X.....	St. Thomas
Y.....	Wixom
Z.....	St. Louis

CK2455-A

### OFFICIAL VEHICLE IDENTIFICATION NUMBER

The official Vehicle Identification Number (VIN) for title and registration purposes is stamped on an aluminum tab that is riveted to the instrument panel.

### VEHICLE CERTIFICATION LABEL

The Vehicle Certification Label (V.C. Label) is attached to the rear face of the driver's door. The upper half of the label contains the name of the manufacturer, the month and year of manufacture and the certification statement. The V.C. label also contains the Vehicle Identification Number. This number is also used for

**100% SATISFACTION GUARANTEED**

**BUY IT NOW!**

**Click Here To Order**

**DATE CODES**

A number signifying the date precedes the month code letter. A second-year code letter will be used if the model exceeds 12 months.

Month	Code First Year	Code Second Year
January	A	N
February	B	P
March	C	Q
April	D	R
May	E	S
June	F	T
July	G	U
August	H	V
September	J	W
October	K	X
November	L	Y
December	M	Z

**DISTRICT CODES (DSO)**

Units built on a Domestic Special Order, Foreign Special Order, or other Special orders will have the complete order number in this space. Also to appear in this space is the two-digit code number of the District which ordered the unit. If the unit is a regular production unit, only the District code number will appear.

**CONSECUTIVE UNIT NUMBER**

Starting Serial Numbers—1970 Passenger Cars  
 100,001 — Ford, Fairlane, Falcon, Mustang, Thunderbird, Maverick  
 500,001 — Mercury, Meteor, Montego, Cougar  
 800,001 — Lincoln Continental & Mark III

**RADIO IDENTIFICATION**

**SAMPLE NUMBER**

DODA	18806	8	260	0	11
↑     ↑	↑	↑	↑	↑	↑
Year    Car Line	Type	Design Level	Manufacturer	Year	Week

**MANUFACTURER CODE NUMBER**

125	Bendix
185	Motorola
260	Philco

**BASIC NUMBER AND TYPE RADIO**

18806	AM Radio
19A241	AM/FM Multiplex
19A242	AM Radio/Stereo Tape Player
19A243	AM—Dual Channel Stereo
19A244	AM Signal Seeking Radio
	Stereo Tape Player Deck

**FORD**

Code	District
11	Boston
13	New York
15	Newark
16	Philadelphia
17	Washington
21	Atlanta
22	Charlotte
24	Jacksonville
25	Richmond
28	Louisville
32	Cleveland
33	Detroit
35	Lansing
37	Buffalo
38	Pittsburgh
41	Chicago
43	Milwaukee
44	Twin Cities
46	Indianapolis
47	Cincinnati
51	Denver
53	Kansas City
54	Omaha
55	St. Louis
56	Davenport
61	Dallas
62	Houston
63	Memphis
64	New Orleans
65	Oklahoma City
71	Los Angeles
72	San Jose
73	Salt Lake City
74	Seattle
75	Phoenix
83	Government
84	Home Office Reserve
85	American Red Cross
89	Transportation Services
90-99	Export

**LINCOLN-MERCURY**

Code	District
11	Boston
15	New York
16	Philadelphia
17	Washington
21	Atlanta
22	Dallas
23	Jacksonville
26	Memphis
31	Buffalo
32	Cincinnati
33	Cleveland
34	Detroit
41	Chicago
42	St. Louis
46	Twin Cities
51	Denver
52	Los Angeles
53	Oakland
54	Seattle
84	Home Office Reserve
90	Export

**FORD OF CANADA**

Code	District
B1	Central
B2	Eastern
B3	Atlantic
I1 thru I7	Export
B4	Midwestern
B6	Western
B7	Pacific

Note: Canadian Lincoln-Mercury units use prefix "A" in place of "B"

**IDENTIFICATION NUMBER**

Number Prefix	Car Line
C9AA	Ford and Meteor
C9ZA	Mustang and Cougar
DOAA	Ford and Meteor
DODA	Maverick
DOGA	Cougar
DOLA	Continental Mark III
DOMA	Mercury
DOOA	Fairlane and Montego
DOSA	Thunderbird
DOVA	Lincoln Continental
DOWA	Cougar
DOYA	Meteor
DOZA	Mustang



**BUY IT NOW!**  
 Click Here To Order



# Charging System

GROUP  
**31**

	PAGE		PAGE
<b>PART 31-01</b>		<b>PART 31-04</b>	
General Charging System Service .....	31-01-01	Leece-Neville Alternators .....	31-04-01
<b>PART 31-02</b>		<b>PART 31-05</b>	
Autolite Alternators .....	31-02-01	Leece-Neville Alternator Regulators ..	31-05-01
<b>PART 31-03</b>		<b>PART 31-06</b>	
Autolite Alternator Regulators .....	31-03-01	Batteries .....	31-06-01

## PART 31-01 General Charging System Service

The alternator and alternator regulator are precision built units, and the equipment to make tests in the charging system must be accurate. Voltmeters must be accurate within 0.1 (one tenth) volt within the range of 12 to 16 volts and ammeters within one ampere at 30 to 65 amperes to permit correct measurement of the alternator and regulator. The meters on Rotunda equipment should be calibrated once a year and the date of calibration stamped on the meter face. It is recommended that this practice be followed by technicians with other than approved equipment in order to maintain their meters at acceptable accuracy.

Certain tests outlined in this section are illustrated in schematic and in

pictorial form. The schematic illustrates the internal connections of the Rotunda equipment so that these connections can be duplicated when this equipment is not available. The Rotunda test units are a combination of accepted instruments incorporated into a single unit. The various circuits involved in the tests can be selected by means of switches without the necessity of changing connections. As a result, the time required to test units and circuits on the vehicle is reduced.

Where applicable, the tests are divided into On The Vehicle and On The Test Bench procedures. Either procedure can be followed depending on the equipment available for the tests.

Trouble shooting or diagnosis is re-

quired before actual repairs are made in the electrical system. Even where an obvious fault makes the replacement of a unit necessary, you must still find out why the unit failed. The trouble shooting procedures given in the Electrical Systems Diagnosis Manual will aid you in making a correct diagnosis. When a trouble is diagnosed correctly, unnecessary repairs are prevented, the time the vehicle is out of service will be decreased, and the repairs that are made will be permanent.

Schematic wiring diagrams (Figs. 1, 2 and 3 Parts 31-02 and 03) of the charging circuits show the internal connections and windings of the various units. Color codes are shown to aid in tracing the circuit.

**100% SATISFACTION GUARANTEED**

**BUY IT NOW!**

**Click Here To Order**



# PART 31-02 Autolite Alternators

COMPONENT INDEX Applies to Models As Indicated	All Models	Ford	Mercury	Meteor	Cougar	Fairlane	Falcon	Maverick	Montego	Mustang	Lincoln-Continental	Thunderbird	Continental-Mark III
ADJUSTMENT—BELT, ALL MODELS	02-10												
DESCRIPTION AND OPERATION													
All Alternators	02-01												
Fuse Link	02-16												
DISASSEMBLY AND OVERHAUL													
38-Ampere Alternator		N/A	N/A	N/A	N/A	02-11	02-11	02-11	02-11	02-11	N/A	N/A	N/A
42-Ampere Alternator		02-11	02-11	02-11	02-11	02-11	02-11	02-11	02-11	02-11	N/A	N/A	N/A
55-Ampere Alternator		02-11	02-11	02-11	02-11	02-11	N/A	N/A	02-11	02-11	N/A	N/A	N/A
55-Ampere Alternator With Integral Voltage Regulator		N/A	N/A	N/A	N/A	N/A	N/A	N/A	N/A	N/A	02-11	02-11	02-11
65-Ampere Alternator		02-14	02-14	N/A	N/A	N/A	N/A	N/A	N/A	N/A	02-14	02-14	02-14
REMOVAL AND INSTALLATION													
All Alternators	02-10												
Fuse Link	02-16												
SPECIFICATIONS	02-17												
TESTING													
Fuse Link	02-16												
With Rotunda (ARE 20-22) Tester	02-02												
With Rotunda (ARE 27-38) Tester	02-03												
Diode Test	02-09												
Field Open or Short Circuit Test	02-08												
Stator Open or Grounded Circuit Tests	02-09												
Stator Neutral Voltage Test	02-07												
Output Test	02-03												

A page number indicates that the item is for the vehicle listed at the head of the column.  
N/A indicates that the item is not applicable to the vehicle listed.

## 1 DESCRIPTION AND OPERATION

The alternator charging system is a negative (-) ground system, and consists of an alternator, a regulator, a charge indicator, a storage battery and associated wiring. Refer to Wiring Diagram Manual Form 7795-P-70 for schematics and locations of wiring harnesses.

### ALTERNATOR

The alternator is belt driven from the engine. Current is supplied from the alternator-regulator system to the rotating field of the alternator through two brushes to two slip rings. The alternator produces power in the form of alternating current. The

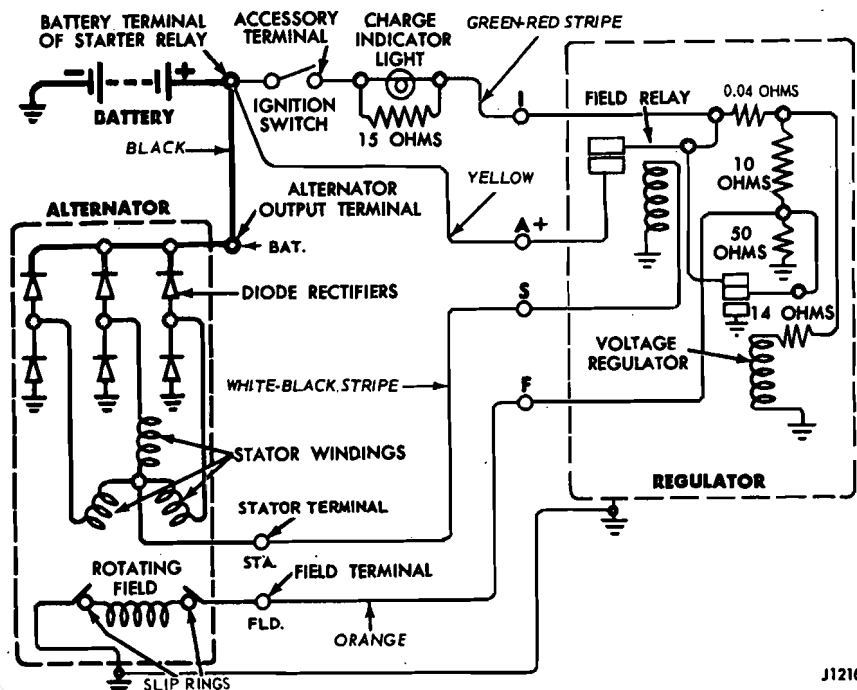

FIG. 1—Autolite Alternator System—Indicator Light

J1210-H

**100% SATISFACTION GUARANTEED**

**BUY IT NOW!**

**Click Here To Order**

PayPal, American Express, Discover, MasterCard, VISA

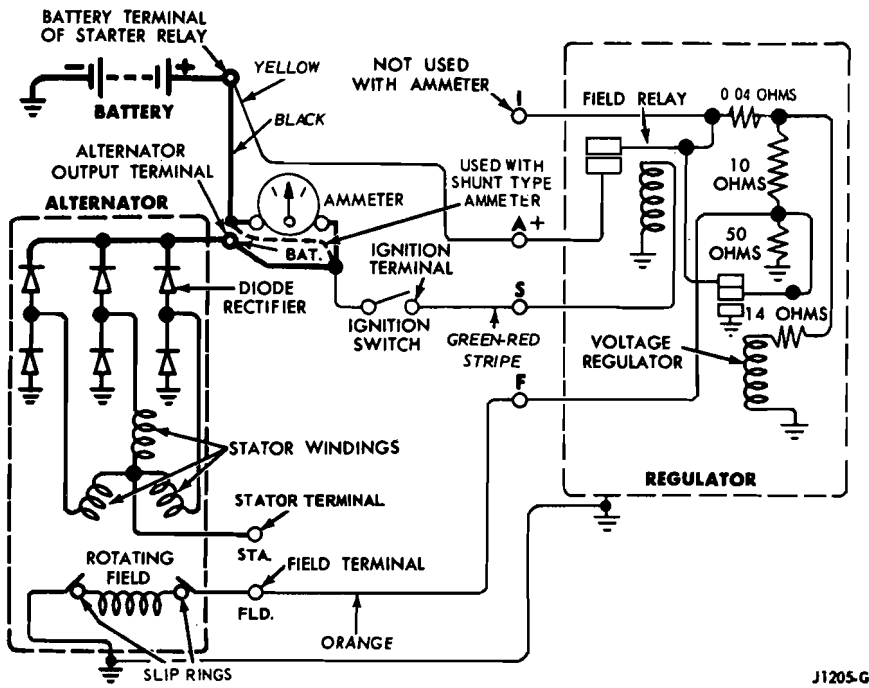

FIG. 2—Autolite Alternator System—Ammeter

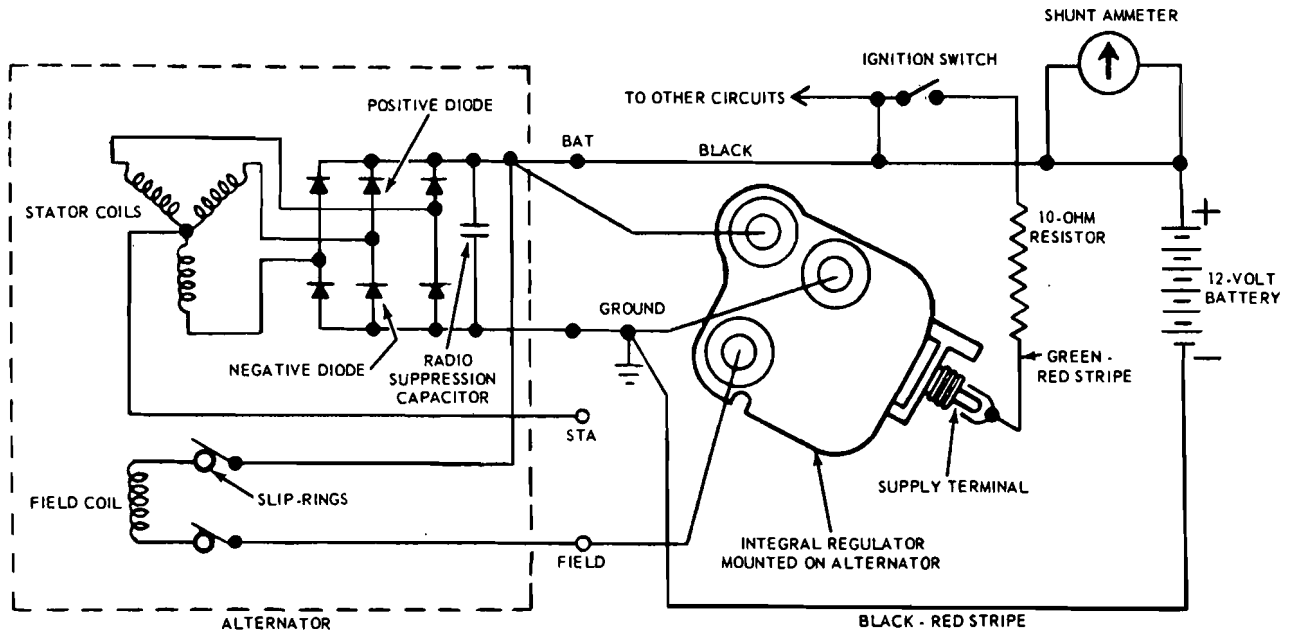

FIG. 3—Autolite Alternator System—With Integral Regulator

## AUTOLITE ALTERNATOR TESTING

**100% SATISFACTION GUARANTEED**

**BUY IT NOW!**

**Click Here To Order**

PayPal, American Express, Discover, MasterCard, VISA

Check the alternator drive belt and adjust it to specification (Section 7 in this part), before proceeding with any

tests. Check and tighten all connectors at the starter relay and battery.

# 1965/72 FORD CAR

FINAL ISSUE

Master Parts and Accessories

Source Document  
Ford Publication Form FP-7635-B

Form FP 7635-A & B

Supersedes All Previous Issues, Changes and Revisions



Official Licensed Product

5236

**FINAL ISSUE**



**BUY IT NOW!**

**Click Here To Order**

Copyright 1975 --

FORD MOTOR  
COMPANY

-- DEARBORN, MICHIGAN

PayPal

Discover  
Cards

Discover  
Novus

MasterCard

VISA







READY REFERENCE

13001

# HOW TO READ WIRING DIAGRAMS



VOL 68 S7 L2A

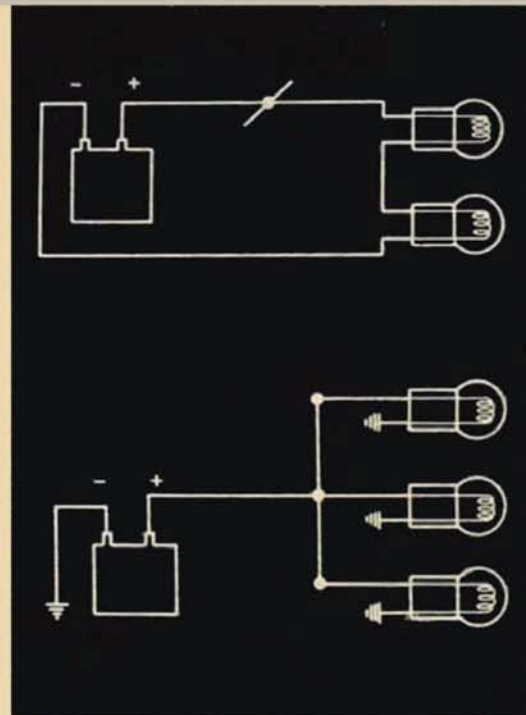

**BUY IT NOW!**

**Click Here To Order**



# HOW TO READ WIRING DIAGRAMS

COURSE 13001 • VOL. 68 S7 L2A

## TABLE OF CONTENTS

Page

### INTRODUCTION

<b>A LOGICAL APPROACH TO ELECTRICAL DIAGNOSIS . . . . .</b>	<b>1</b>
Like reading a road map . . . . .	2
How wires are numbered and color-coded . . . . .	2
<b>CIRCUIT – A COMPLETE ELECTRICAL PATH BETWEEN TWO POINTS . . . . .</b>	<b>5</b>
2-wire circuit . . . . .	6
Single wire circuit . . . . .	6
Ground connections . . . . .	7
<b>OPEN CIRCUITS . . . . .</b>	<b>8</b>
Shorts . . . . .	9
Grounded circuit . . . . .	9
Series and parallel open circuits . . . . .	10
<b>BREAKS IN PARALLEL CIRCUITS . . . . .</b>	<b>11</b>
Common points . . . . .	14
Splices . . . . .	15
Fuses and circuit breakers . . . . .	17
Quick disconnects . . . . .	18
Male and female elements . . . . .	20
Types of quick disconnects . . . . .	22
<b>HINTS FOR TRACING WIRES THROUGH A DRAWING . . . . .</b>	<b>23</b>
Curve directions . . . . .	23
Common points . . . . .	24
Switches . . . . .	25
Relays . . . . .	26
Assemblies . . . . .	28
Locating the assembly . . . . .	29
Finding the wire . . . . .	30
<b>SUMMARY . . . . .</b>	<b>31</b>

100% SATISFACTION GUARANTEED

**BUY IT NOW!**

Click Here To Order

The descriptions, testing procedures, and specifications in this handbook were approved for printing. Ford Motor Company reserves the right to change specifications without notice and without incurring

NATIONAL SERVICE OFFICE  
FORD DIVISION



FIRST PRINTING – JANUARY, 1968

© 1968 FORD MOTOR COMPANY  
DEARBORN, MICHIGAN

# INTRODUCTION

## *The Why and Wherefore of Wiring Diagrams*

To the uninformed, a wiring diagram — or a wiring assembly — looks like it might take a genius to figure out.

Not so — as you'll find out when you get better acquainted with these subjects.

There're as understandable and logical as a road map and road markers, when you're finding your way on a cross-country drive.

The ability to read a wiring diagram and relate it to a vehicle's wiring system is, of course, an essential part of a modern service technician's skill. And it's growing in relative importance, too, due to owner's increasing demands for the comforts and conveniences supplied by electrically-operated options and accessories. This opens up greater opportunities, for the forward-looking technician.

## *The Purpose of this Booklet . . .*

. . . is to acquaint you with the systems by which electrical circuits are traced on vehicles. Specifically, it is designed to help you acquire the ability to make your own power checks, quickly and accurately.

## *Scope of the Booklet*

Basically, this is a printed version of the film, "How to Read a Wiring Diagram." It is in no sense a manual of the shop methods by which electrical repairs are made.

It *can* be a helpful guide that can introduce you to the principles of wiring diagrams and vehicle wiring. As you gain experience in reading wiring diagrams, you'll accumulate your own know-how in this important skill. When it becomes "second nature" to you, these pages will have served their purpose — and yours.



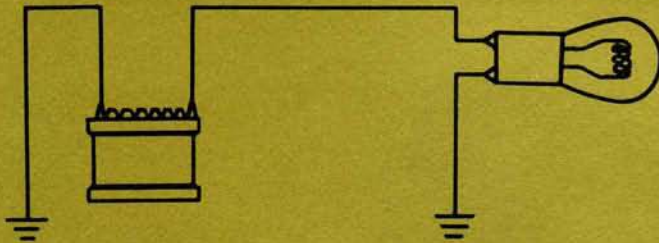

To show how to read wiring diagrams — and to explain how they can be used to help you troubleshoot problems in the electrical system — is what this booklet is all about. Obviously, these are important subjects.

## A LOGICAL APPROACH TO ELECTRICAL DIAGNOSIS



If a customer comes in because his headlights aren't working, you can't just make a snap decision. That's not the *professional way*.

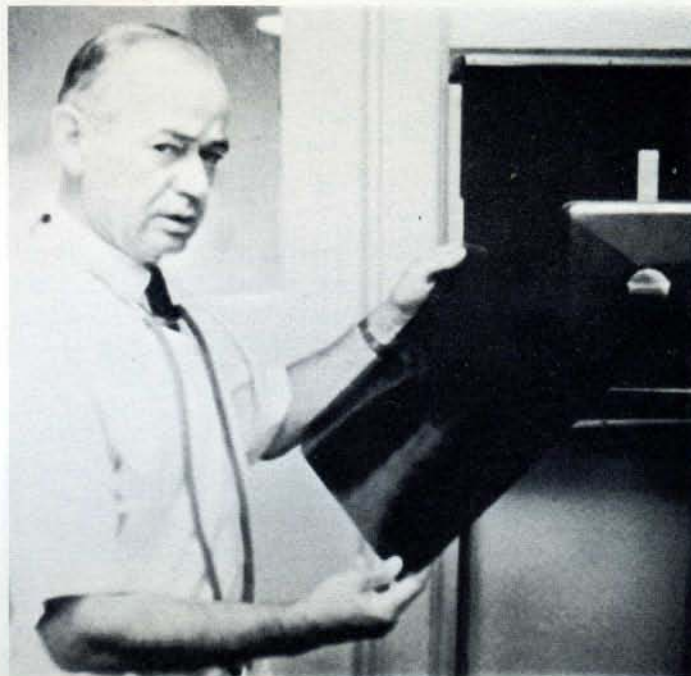

When you go to a doctor, for example, he tries to find out what's *really* wrong with you. He looks beyond the aches and pains you feel, to see what's *causing* the trouble. We call this, *diagnosis*.

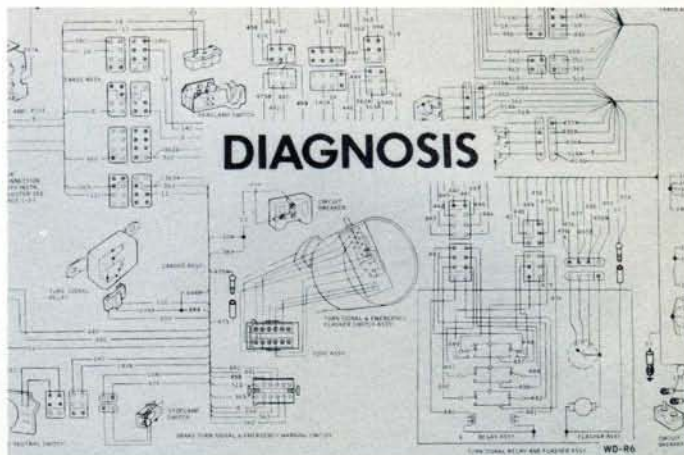

Troubleshooting an electrical system calls for diagnosis, too — *Your* diagnosis. *You're* the doctor. You must find out what's causing the trouble, and fix it.



**BUY IT NOW!**

**Click Here To Order**

unit may be the way may not. Snap professional.

