

# 1970 CAR SHOP MANUAL

VOLUME ONE  
CHASSIS



**BUY IT NOW!**

**Click Here To Order** 

PayPal

MasterCard

DISCOVER  
NEWUS

MasterCard

VISA

METEOR

MAVERICK

FALCON

FAIRLANE

MUSTANG

FORD

THUNDERBIRD

MONTEGO

COUGAR

MERCURY

LINCOLN  
CONTINENTAL

CONTINENTAL  
MARK III

Copyright © 2007, Forel Publishing Company, LLC, Woodbridge, Virginia

All Rights Reserved. No part of this book may be used or reproduced in any manner whatsoever without written permission of Forel Publishing Company, LLC. For information write to Forel Publishing Company, LLC, 3999 Peregrine Ridge Ct., Woodbridge, VA 22192

1970 Ford Car Shop Manual  
ISBN: 0-9673211-7-4  
EAN: 978-0-9673211-7-2

***Forel Publishing Company, LLC***  
***3999 Peregrine Ridge Ct.***  
***Woodbridge, VA 22192***  
***Email address: [webmaster@ForelPublishing.com](mailto:webmaster@ForelPublishing.com)***  
***Website: <http://www.ForelPublishing.com>***



This publication contains material that is reproduced and distributed under a license from Ford Motor Company. No further reproduction or distribution of the Ford Motor Company material is allowed without the express written permission of Ford Motor Company.

---

## Disclaimer

Although every effort was made to ensure the accuracy of this book, no representations or warranties of any kind are made concerning the accuracy, completeness or suitability of the information, either expressed or implied. As a result, the information contained within this book should be used as general information only. The author and Forel Publishing Company, LLC shall have neither liability nor responsibility to any person or entity with respect to any loss or damage caused, or alleged to be caused, directly or indirectly by the information contained in this book. Further, the publisher and author are not engaged in rendering legal or other professional services. If legal, mechanical, electrical, or other expert assistance is required, the services of a competent professional should be sought.



# VOLUME ONE CHASSIS

## GROUP INDEX

INDEX and IDENTIFICATION 10

WHEELS and TIRES 11

BRAKES 12

STEERING 13

SUSPENSION 14

DRIVING AXLES and DRIVESHAFT 15

MANUAL TRANSMISSION and CLUTCH (TRANSFER CASE and AUXILIARY TRANSMISSION) 16

AUTOMATIC TRANSMISSION 17

VOLUME TWO

INDEX and IDENTIFICATION .....	20
ENGINE .....	21
IGNITION SYSTEM .....	22
FUEL SYSTEM .....	23
COOLING SYSTEM .....	24
EXHAUST SYSTEM .....	25
STARTING SYSTEM .....	28

VOLUME THREE

INDEX and IDENTIFICATION .....	30
CHARGING SYSTEM .....	31
EXTERIOR LIGHTS, HEADLIGHT DIMMER, TURN SIGNALS, HORN .....	32
INTERIOR LIGHTS, INSTRUMENTS, INSTRUMENT PANEL CONTROLS, CLOCK .....	33
VENTILATING, HEATING, AIR CONDITIONING .....	34
AUXILIARY EQUIPMENT: RADIO, STEREO, WINDSHIELD WIPER and WASHER, LIGHTERS, ASH RECEPTACLES, MIRRORS, Etc. ....	35
WIRING, CIRCUIT PROTECTION, BULB CHARTS .....	36
VACUUM SYSTEMS .....	37
SPEED CONTROL, ANTI-SKID CONTROL .....	38

VOLUME FOUR

INDEX and IDENTIFICATION .....	40
SEATS .....	41
WINDOWS (MANUAL and POWER) .....	42
DOORS, HOODS, LUGGAGE COMPARTMENT DOORS, TAILGATES .....	43
WINDSHIELD, BACK WINDOW, FIXED GLASS .....	44
CONVERTIBLE TOPS, SUN ROOF PANEL .....	45
ROOF OUTSIDE COVER, WOOD GRAIN TRANSFER, VINYL ROOFS, PAINT .....	46
INTERIOR TRIM .....	47
BODY SHELL, EXTERIOR TRIM, FRAMES, UNDERBODY .....	48

VOLUME FIVE

INDEX and IDENTIFICATION .....	50
PRE-DELIVERY SEQUENCE GUIDES .....	51
MAINTENANCE SCHEDULE .....	52
SALES AND SERVICE .....	53
INDEX .....	54



**BUY IT NOW!**

Click Here To Order



LOCATIONS

FIRST PRINTING - SEPTEMBER, 1969  
© 1969 FORD MOTOR COMPANY, DEARBORN, MICHIGAN

# FOREWORD

*This manual is divided into five volumes: 1 – Chassis, 2 – Engine, 3 – Electrical, 4 – Body, 5 – Maintenance and Lubrication. These volumes should provide Service Technicians with complete information covering normal service repairs on all 1970 model passenger cars built by Ford Motor Company in the U.S. and Canada. As changes in the product occur, this information will be updated by Technical Service Bulletins. When issued, TSB information always supersedes that published here.*

*Within each volume, information is grouped by system or component plus “General Service” parts which contain information which is common to several similar components.*

*The table of contents on the first page of each volume indicates the general content of the book and provides a handy tab locator to make it easy to find the first page of each “group.” That page will contain an index to “parts” and the first page of each “part” contains a detailed index which gives page location for each service operation covered. Page numbers are consecutive in each “part.”*

*Those who have previously used Ford Shop Manuals will find a major change this year in the division of information into “groups” and “parts.” To make reference easier, information has been broken down into smaller units so that essentially there is now one “part” for each component or system. Group numbers have been changed so that the first digit of the number indicates the volume in which the group may be found.*

*Example:*

36 – 05 – 13  
Volume 3 – Group 6 – Part 5 – Page 13

*We hope that this change in indexing will make it easier and quicker to locate desired information within these manuals.*

*The descriptions and specifications in this manual were in effect at the time this manual was approved for printing. Ford Motor Company reserves the right to discontinue models at any time, or change specifications or design, without notice and without incurring obligation.*

 **SERVICE PUBLICATIONS**

**Official Licensed Product**

*Ford Motor Company*

5006

July 1997



# Index and Vehicle Identification

**GROUP**  
10



W 1002-B

Fig. 1 — Typical Vehicle Identification Number

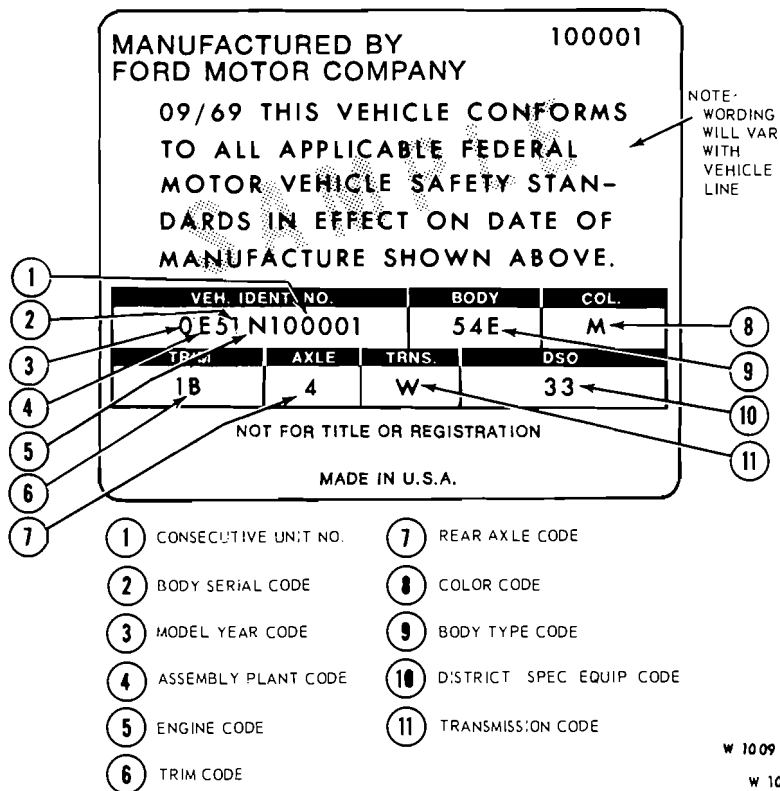

W 1009-A  
W 1009-A

FIG. 2 — Vehicle Certification Label

Warranty identification of the vehicle. The first number indicates the model year. The letter following the model year number indicates the manufacturing assembly plant. The next two numbers designate the Body Serial Code followed by a letter expressing the Engine Code. The last six digits of the Vehicle Identification Number indicate the Consecutive Unit Number.

The remaining information on the V.C. Label consists of pertinent vehicle identification codes. The BODY code is two numerals and a letter identifying the body style. The COL (color) code is a number or letter (or both) indicating the exterior paint color code. The TRIM code consists of a number-letter combination designating the interior trim. The Axle code is a number or letter indicating the rear axle ratio and standard or locking type axles. The TRNS. code is a number or letter indicating the type of transmission, numerals for manual and letters for automatic or semi-automatic. The DSO code consisting of two numbers designates the district in which the car was ordered and may appear in conjunction with a Domestic Special Order or Foreign Special Order number when applicable. Ford of Canada DSO codes consist of a letter and a number except for export codes which are designated by two numbers.

**MODEL YEAR CODE**

The number 0 designates 1970.

**ASSEMBLY PLANT CODES**

Code Letter	
A	Atlanta
B	Oakville (Canada)
D	Dallas
E	Mahwah
F	Dearborn
G	Chicago
H	Lorain
J	Los Angeles
K	Kansas City
N	Norfolk
P	Twin Cities
R	San Jose
S	Allen Park
T	Metuchen
U	Louisville
W	Wayne
X	St. Thomas
Y	Wixom

**OFFICIAL VEHICLE IDENTIFICATION NUMBER**

**VEHICLE CERTIFICATION LABEL**

The Vehicle Certification Label (V.C. Label) is attached to the rear face of the driver's door. The upper half of the label contains the name of the manufacturer, the month and year of manufacture and the certification statement. The V.C. label also contains the Vehicle Identification Number. This number is also used for

100% SATISFACTION GUARANTEED

BUY IT NOW!

Click Here To Order

**BODY SERIAL AND STYLE CODES**

The two-digit numeral which follows the assembly plant code identifies the body series. This two-digit number is used in conjunction with the Body Style Code, in the Vehicle Data, which consists of a two-digit number with a letter suffix. The following chart lists the Body Serial Codes, Body Style Codes and the model.

**LINCOLN CONTINENTAL**

Body Serial Code	Body Style Code	Body Type
82	53A	4 - Door Sedan
81	65A	2 - Door Hardtop

**MARK III**

Body Serial Code	Body Style Code	Body Type
89	65A	2 - Door Hardtop

**COUGAR**

Body Serial Code	Body Style Code	Body Type	Model
91	65A	2 - Door Hardtop ⊕	Standard
92	76A	Convertible ⊕	
93	65B	2 - Door Hardtop ⊕	XR-7 Luxury
94	76B	Convertible ⊕	

⊕Bench Seat   ⊕Split Bench   ⊕Bucket Seats

**MERCURY**

Body Serial Code	Body Style Code	Body Type	Model
44	54A	4 - Door Sedan ⊕	Monterey
46	65A	2 - Door Hardtop ⊕	
48	57A	4 - Door Hardtop ⊕	
45	76A	Convertible ⊕	
<b>CANADA ONLY</b>			
40	53M	4 - Door Hardtop Sedan ⊕	Marquis
41	65M	2 - Door Hardtop—Formal ⊕	
42	57M	4 - Door Hardtop ⊕	
54	54C	4 - Door Sedan ⊕	Monterey—Custom
56	65B	2 - Door Hardtop ⊕	
58	57B	4 - Door Hardtop ⊕	
63	53F	4 - Door Hardtop Sedan ⊕ ⊕	Marquis
66	65F	2 - Door Hardtop ⊕ ⊕	
68	57F	4 - Door Hardtop ⊕ ⊕	
65	76F	Convertible ⊕ ⊕	
62	53C	4 - Door Hardtop Sedan ⊕	Brougham
64	65C	2 - Door Hardtop ⊕	
67	57C	4 - Door Hardtop ⊕	
63G		2 - Door Hardtop (Tunnel Roof) ⊕ ⊕ Marauder (of)	
			Monterey Wagon ⊕

**MERCURY (Cont'd.)**

Body Serial Code	Body Style Code	Body Type	Model
74	71F	4 - Door 2 Seat ⊕	Monterey—Custom Wagon
*74	71G	4 - Door 3 Seat (Side Facing) ⊕	
76	71E	4 - Door 2 Seat ⊕ ⊕	Marquis Colony Park
*76	71A	4 - Door 3 Seat (Side Facing) ⊕ ⊕	

⊕Bench Seat   ⊕Split Bench   ⊕Bucket Seats  
\*Merchandised as Options

**METEOR (CANADA)**

Body Serial Code	Body Style Code	Body Type	Model
20	54A	4 - Door Sedan ⊕	Rideau
22	54B	4 - Door Sedan ⊕	Rideau 500
23	65B	2 - Door Hardtop—Formal ⊕	
25	54C	4 - Door Sedan ⊕ ⊕	Montcalm
26	65C	2 - Door Hardtop ⊕ ⊕	
*26	65E	2 - Door Hardtop ⊕ ⊕	
27	57C	4 - Door Hardtop ⊕ ⊕	
28	76C	Convertible ⊕ ⊕	
*28	76E	Convertible ⊕ ⊕	
34	65F	2 - Door Hardtop—Formal ⊕ ⊕	LeMoine
35	57F	2 - Door Hardtop ⊕ ⊕	
36	71B	Rideau 500—6 Passenger ⊕	Station Wagons—4 Door
37	71C	Rideau 500—Dual Face Rear ⊕	
38	71E	Montcalm—6 Passenger ⊕	
39	71A	Montcalm—Dual Face Rear ⊕	

⊕Bench Seat   ⊕Split Bench   ⊕Bucket Seats  
\*Merchandised as Options

**MONTEGO**

Body Serial Code	Body Style Code	Body Type	Model
01	65A	2 - Door Hardtop ⊕	Montego
02	54A	4 - Door Sedan ⊕	
06	54B	4 - Door Sedan ⊕	Montego MX
07	65B	2 - Door Hardtop ⊕	
10	54D	4 - Door Sedan ⊕	Montego MX Brougham
11	65D	2 - Door Hardtop ⊕	
12	57D	4 - Door Hardtop ⊕	
*07	65E	2 - Door Hardtop ⊕	Montego MX
05	57B	4 - Door Hardtop ⊕	
15	65F	2 - Door Hardtop ⊕	Cyclone
*15	65F	2 - Door Hardtop ⊕	
17	65G	2 - Door Hardtop ⊕	Cyclone Spoiler
16	65H	2 - Door Hardtop ⊕	Cyclone GT
08	71C	Montego MX ⊕	Station Wagon—4 Door
18	71A	Montego MX (Woodgrain Villager) ⊕	

⊕Bench Seat   ⊕Split Bench   ⊕Bucket Seats  
\*Merchandised as Options



**BUY IT NOW!**

**Click Here To Order**



**THUNDERBIRD**

Body Serial Code	Body Style Code	Body Type	Model
*83	65A	2 - Door Hardtop ⊕	
83	65C	2 - Door Hardtop ⊕	
*84	65B	2 - Door Landau ⊕	
84	65D	2 - Door Landau ⊕	
*87	57B	4 - Door Landau ⊕	
87	57C	4 - Door Landau ⊕	
⊕Bench Seat		⊕Split Bench	⊕Bucket Seats
*Merchandised as Options			

**FALCON**

Body Serial Code	Body Style Code	Body Type	Model
10	62A	2 - Door Sedan ⊕	Standard
11	54A	4 - Door Sedan ⊕	
20	62B	2 - Door Sedan ⊕	Futura
21	54B	4 - Door Sedan ⊕	
12	71A	4 - Door Standard ⊕	Station Wagon
23	71B	4 - Door Futura ⊕	
⊕Bench Seat		⊕Split Bench	⊕Bucket Seats

**MAVERICK**

Body Serial Code	Body Style Code	Body Type	Model
91	62A	2 - Door Sedan	Standard

**MUSTANG**

Body Serial Code	Body Style Code	Body Type	Model
01	65A	2 - Door Hardtop ⊕	Standard
02	63A	2 - Door Fastback ⊕	
03	76A	Convertible ⊕	
*01	65B	2 - Door Hardtop ⊕	Flair
*02	63B	2 - Door Fastback ⊕	
*03	76B	Convertible ⊕	
04	65E	2 - Door Hardtop ⊕	"Grande"
05	63C	2 - Door Fastback ⊕	"Mach I"
⊕Bench Seat		⊕Split Bench	⊕Bucket Seats
*Merchandised as Options			

**FORD (Cont'd.)**

Body Serial Code	Body Style Code	Body Type	Model
54	54A	4 - Door Sedan ⊕	Galaxie 500
55	63B	2 - Door Hardtop Fastback ⊕	
58	65C	2 - Door Hardtop Formal ⊕	
56	57B	4 - Door Hardtop ⊕	
60	63C	2 - Door Hardtop Fastback ⊕ ⊕	Ford XL
61	76B	Convertible ⊕ ⊕	
64	54C	4 - Door Sedan ⊕ ⊕	Ford LTD
62	65A	2 - Door Hardtop Formal ⊕ ⊕	
66	57F	4 - Door Hardtop ⊕ ⊕	
70	71D	Ranchwagon-6 Passenger ⊕	Station Wagon
71	71H	Custom 500 Ranchwagon-6 Passenger ⊕	
72	71J	Custom 500 Ranchwagon-Dual Face Rear ⊕	
73	71B	Country Sedan-6 Passenger ⊕	
74	71C	Country Sedan-Dual Face Rear ⊕	
75	71E	Country Squire-6 Passenger ⊕	
76	71A	Country Squire-Dual Face Rear ⊕	
⊕Bench Seat		⊕Split Bench	⊕Bucket Seats

**FAIRLANE**

Body Serial Code	Body Style Code	Body Type	Model
28	54B	4 - Door Sedan ⊕	Fairlane 500
29	65B	2 - Door Hardtop ⊕	
30	65C	2 - Door Hardtop ⊕	Torino
31	54C	4 - Door Sedan ⊕	
32	57C	4 - Door Hardtop ⊕	
*30	65C	2 - Door Hardtop ⊕	Torino
33	65E	2 - Door Hardtop - Formal ⊕	Torino Brougham
36	57E	4 - Door Hardtop ⊕	
35	63F	2 - Door Hardtop - Fastback ⊕	Torino GT
37	76F	Convertible ⊕	
*35	63F	2 - Door Hardtop - Fastback ⊕	Torino GT
*37	76F	Convertible ⊕	
38	63H	2 - Door Hardtop - Fastback ⊕	Cobra
*38	63H	2 - Door Hardtop - Fastback ⊕	Cobra
41	71B	Fairlane 500 ⊕	Station Wagon
42	71C	Torino ⊕	4 - Door
43	71E	Torino Squire (Brougham) ⊕	
46	66A	Ranchero ⊕	Ranchero
47	66B	Ranchero 500 ⊕	
*47	66B	Ranchero 500 ⊕	Ranchero
48	66C	Ranchero GT ⊕	Ranchero
*48	66C	Ranchero GT ⊕	
49	66E	Ranchero Squire ⊕	
*49	66E	Ranchero Squire ⊕	
⊕Bench Seat		⊕Split Bench	⊕Bucket Seats
*Merchandised as Options			

**FORD**

Body Serial Code	Body Style Code	Body Type	Model
			Custom
			Custom 500



**BUY IT NOW!**

Click Here To Order



REAR AXLE RATIO CODES

Conventional	Limited-Slip	Ratio
0		2.50:1
2	K	2.75:1
3		2.79:1
4	M	2.80:1
5		2.83:1
6	O	3.00:1
7		3.10:1
8		3.20:1
9	H	3.25:1
A	S	3.50:1
B		3.07:1
C		3.08:1
F	X	2.33:1
	V	3.91:1
	W	4.30:1

TRANSMISSION CODES

Code	Type
1	3 - Speed Manual
5	4 - Speed Manual - wide ratio
6	4 - Speed Manual - close ratio
V	Semi - Automatic Stick Shift
W	Automatic (C4)
U	Automatic (C6)
X	Automatic (FMX)
Z	Automatic (C6 Special)

ENGINE CODES

Code	Type
U	6 Cyl. 170 Cu. In. (1V)
T	6 Cyl. 200 Cu. In. (1V)
2	6 Cyl. 200 Cu. In. (1V)
L	6 Cyl. 250 Cu. In. (1V)
3	6 Cyl. 250 Cu. In. (1V)
V	6 Cyl. 240 Cu. In. (1V)
5	6 Cyl. 240 Cu. In. (1V)
B	6 Cyl. 240 Cu. In. (1V) Police
E	6 Cyl. 240 Cu. In. (1V) Taxi
F	8 Cyl. 302 Cu. In. (2V)
6	8 Cyl. 302 Cu. In. (2V)
D	8 Cyl. 302 Cu. In. (2V) Taxi
G	8 Cyl. 302 - 4V HO
H	8 Cyl. 351 Cu. In. (2V)
M	8 Cyl. 351 Cu. In. (4V)
Y	8 Cyl. 390 Cu. In. (2V) Regular
Q	8 Cyl. 428 Cu. In. (4V) CJ
R	8 Cyl. 428 Cu. In. (4V) CJ Ram Air
P	8 Cyl. 428 Cu. In. (4V) Police
K	8 Cyl. 429 Cu. In. (2V)
N	8 Cyl. 429 Cu. In. (4V)
C	8 Cyl. 429 - 4V - CJ
Z	8 Cyl. 429 - 4V - HO
J	8 Cyl. 429 - 4V CJ Ram Air
A	8 Cyl. 460 Cu. In. (4V)

Ⓛ Low Compression    Ⓧ Premium Fuel  
 Ⓢ Improved Performance  
 Ⓢ High Performance    Ⓢ Ram Air Induction

EXTERIOR PAINT COLOR CODES

Color	M-32-J Number	Color
A	1724-A	Black
B	3316-A	Dk. Maroon
C	3323-A	Dk. Ivy Green Met.
D	3470-A	Br. Yellow-Competition Yellow
E	1906-A	Lt. Blue
F	3065-A	Dk. Aqua Met (Brt.)-Dk. Aqua Met.
G	3075-A	Med. Avacado Met.-Med. Lime Met.
H	2067-A	Lt. Green
I	3204-A	Dk. Orchid Met.
J	3320-A	Br. Blue Met. (Astra)-Deep Blue Met.
K	3340-A	Yellow Met.-Br. Gold Met. (Freudian Gilt/Maverick)-Deep Gold Met.
L	3318-A	Lt. Gray Met.
M	1619-A	White
N	921-A	Platinum-Pastel Blue
O	3202-A	Burnt Orange Met.- (Original Cinnamon/Maverick)
P	3401-A	Med. Ivy Green Met.
Q	3319-A	Med. Blue Met.
R	3342-A	Dk. Brown Met.
S	3199-A	Nugget Gold Met.-Med. Gold Met.
T	2008-A	Red
U	1070-A	Med. Aqua Met.
W	3341-A	Yellow
X	3063-A	Dk. Blue
Y	3347-A	Chestnut Met.-Chestnut Bronze Met.-Med. Bronze Met.
Z	3346-A	Dk. Slate Gray Met.-Dk. Gray Met.
1	1730-A	Calypto Coral-Vermilion -Competition Orange
2	3071-A	Lt. Ivy Yellow
5	3564-A	Ginger Met.-Med. Brown Met.
6	3077-A	Med. Brt. Blue Met.-Bright Blue Met.-Hulla Blue/Maverick
7	3812-A	Med. Peppermint Met.- (Anti-Establishment Mint/Maverick)
8	3198-A	Lt. Gold
9	3120-A	Yellow/Pastel Yellow

GLAMOUR PAINTS-Opt.

Vendor=	Grabber Paints	
19	3595-A	Ivy Bronze Met.-Green Fire-Green Stardust
09	3597-A	Olive Bronze Met.-Olive Fire-Olive Stardust
89	3333-A	Fall Bronze Met.-Bronze Fire-Bronze Stardust
59	3275-A	Med. Red Met.-Burgundy Fire-Red Stardust
J	0470	Grabber Blue (Med.)-Competition Blue
U	6166	Grabber Orange (Dk.)-Competition Gold
Z	4359	Grabber Green (Med.)-Competition Green

INTERIOR TRIM CODES

Code	Trim Schemes
1A	Black Vinyl
1A	Black Cloth & Vinyl
1A	Black Cloth & Black Vinyl
1A	Black Knit & Vinyl
1B	Med./Lt. Blue Vinyl
1B	Dk. Blue Cloth & Vinyl
1B	Dk. Blue Knit & Vinyl
1B	Med. Blue Vinyl
1B	Med. Blue Cloth & Vinyl
1D	Dk. Red Vinyl
1D	Dk. Red Knit & Vinyl
1D	Dk. Red Cloth and/or Dk. Red Vinyl
1F	Med. Ginger Vinyl
1F	Med. Ginger Cloth & Vinyl
1G	Dk. Ivy Green Cloth & Vinyl
1G	Med. Ivy Green Vinyl
1G	Med. Ivy Green Cloth & Vinyl
1G	Med. Green Cloth & Vinyl
1G	Dk. Ivy Green Knit & Vinyl
1P	Med. Grey Cloth & Vinyl
1Y	Lt. Nugget Gold Vinyl
1Y	Lt. Nugget Gold Cloth & Vinyl
1Y	Lt. Gold Cloth & Vinyl
1Z	Dk. Tobacco Vinyl
1Z	Dk. Tobacco Knit & Vinyl
2A	Black Vinyl
2A	Black Leather & Vinyl
2A	White & Black Cloth & Black Vinyl
2A	Black Knit & Vinyl
2B	Dk. & Lt. Blue Vinyl
2B	Dk. Blue Leather & Vinyl
2B	Med. Blue Vinyl
2B	Dk. Blue Knit & Vinyl
2B	Med. Blue & Black Cloth & Med. Blue Vinyl
2D	Dk. Red Vinyl
2D	Dk. Red Leather & Vinyl
2D	Dk. Red & Black Cloth & Dk. Red Vinyl
2F	Med. Ivy Green Vinyl
2F	Med. Ginger Vinyl
2F	Med. Brown Vinyl
2F	Med. Ginger Leather & Vinyl
2G	Dk. Ivy Green Vinyl
2G	Med. Green Vinyl
2G	Dk. Ivy Green Knit & Vinyl
2G	Dk. Ivy Green Leather & Vinyl
2K	Lt. Aqua Leather & Vinyl
2P	Med. Grey Leather & Vinyl
2W	White Vinyl
2W	White Leather & Vinyl
2W	White Vinyl With Black
2W	White Knit & Vinyl
2Y	Lt. Gold Vinyl
2Y	Lt. Nugget Gold Vinyl
2Y	Lt. Nugget Gold Leather & Vinyl
2Y	Lt. Nugget & Black Cloth & Lt. Nugget Gold Vinyl
2Z	Dk. Tobacco Leather & Vinyl
3A	Black Vinyl With Red Strip
3A	Black Cloth & Vinyl
3A	Black Leather & Vinyl
3A	Med. Blue Cloth & Vinyl
3B	Med. Blue Knit & Vinyl
3B	Med. Blue Cloth & Vinyl
3B	Dk. Blue Cloth & Vinyl
3B	Dk. Blue Leather & Vinyl
3B	Med. Blue Cloth & Lt. Blue Vinyl
3B	Med. Blue Vinyl
3D	Dk. Red Cloth & Vinyl
3D	Dk. Red Leather & Vinyl
3E	Vermilion Vinyl

CUTIVE UNIT NUMBER

Serial Numbers - 1970 Passenger Cars

**100% GUARANTEED**

**BUY IT NOW!**

Click Here To Order

PayPal    American Express    Discover    MasterCard    VISA

INTERIOR TRIM CODES-(continued)

Code	Trim Schemes
3E.....	Vermilion Knit & Vinyl
3F.....	Med. Brown Cloth & Vinyl
3F.....	Med. Ginger Knit & Vinyl
3F.....	Med. Ginger Leather & Vinyl
3F.....	Med. Ginger Vinyl
3F.....	Med. Ginger Cloth & Vinyl
3G.....	Med. Ivy Green Knit & Vinyl
3G.....	Med. Ivy Green Leather & Vinyl
3G.....	Med. Ivy Green Vinyl
3G.....	Med. Ivy Green Cloth & Vinyl
3G.....	Dk. Ivy Green Cloth & Vinyl
3K.....	Lt. Aqua Leather & Vinyl
3K.....	Lt. Aqua Cloth & Lt. Aqua Vinyl
3P.....	Med. Grey Leather & Vinyl
3W.....	White Leather & Vinyl
3W.....	White With Black Knit & Vinyl
3Y.....	Lt. Nugget Leather & Vinyl
3Y.....	Lt. Nugget Gold Cloth & Vinyl
3Z.....	Dk. Tobacco Leather & Vinyl
4A.....	Black Vinyl
4A.....	Black Cloth & Vinyl
4A.....	Dk. Black Knit & Vinyl
4B.....	Dk. Blue Knit & Vinyl
4B.....	Dk./Lt. Blue Vinyl
4B.....	Med. Blue Cloth & Vinyl
4B.....	Med. Blue Vinyl
4D.....	Dk. Red Vinyl
4F.....	Med. Ginger Vinyl
4F.....	Med. Brown Vinyl
4G.....	Dk. Ivy Green Knit & Vinyl
4G.....	Dk. Ivy Green Vinyl
4W.....	White Vinyl
4W.....	White Knit & Vinyl With Black
4Y.....	Lt. Gold Cloth & Vinyl
4Y.....	Lt. Nugget Gold Cloth & Vinyl
4Y.....	Lt. Nugget Gold Vinyl
5A.....	Black Knit & Vinyl
5A.....	Black Cloth and/or Black Vinyl
5A.....	Black Vinyl
5B.....	Med. Blue Cloth & Vinyl
5B.....	Med. Blue Knit & Vinyl
5B.....	Med. Blue Vinyl
5B.....	Dk. Blue Cloth & Vinyl
5D.....	Dk. Red Cloth & Vinyl
5D.....	Dk. Red Knit & Vinyl
5D.....	Dk. Red Vinyl
5F.....	Med. Brown Vinyl
5F.....	Med. Ginger Knit & Vinyl
5F.....	Med. Ginger Vinyl
5G.....	Med. Ivy Green Cloth & Vinyl
5G.....	Dk. Green Cloth & Vinyl
5G.....	Med. Ivy Green Knit & Vinyl
5G.....	Med. Green Vinyl &/or Cloth
5K.....	Lt. Aqua Cloth & Vinyl
5K.....	Lt. Aqua Knit & Vinyl
5Y.....	Lt. Nugget Gold Cloth & Vinyl
5Y.....	Lt. Gold Cloth & Vinyl
5Y.....	Lt. Nugget Gold Knit & Vinyl
5Z.....	Dk. Tobacco Knit & Vinyl
5Z.....	Dk. Tobacco Cloth & Vinyl
6A.....	Black Knit & Vinyl
6A.....	Black Vinyl
6A.....	Black Grain Leather
6A.....	Black Grain Leather &/or Vinyl
6B.....	Med. Blue Grain Leather With Vinyl
6B.....	Med. Blue Grain Leather
6B.....	Med. Blue Vinyl

INTERIOR TRIM CODES-(continued)

Code	Trim Schemes
6F.....	Med. Ginger Vinyl
6F.....	Med. Ginger Grain Leather
6G.....	Med. Ivy Green Vinyl
6G.....	Med. Ivy Green Grain Leather
6G.....	Med. Green Vinyl
6G.....	Med. Green Cloth & Vinyl
6W.....	White Cloth & Vinyl
6W.....	White Vinyl With Black
6Y.....	Lt. Nugget Gold Vinyl
6Y.....	Lt. Nugget Gold Cloth & Vinyl
6Z.....	Dk. Tobacco Grain Leather
6Z.....	Dk. Tobacco Vinyl
6Z.....	Dk. Tobacco Grain Lether &/or Vinyl
6Z.....	Dk. Brown Leather & Vinyl
7A.....	Black Vinyl
7A.....	Black Cloth & Vinyl
7A.....	Black Leather & Vinyl
7B.....	Dk. Blue Leather & Vinyl
7B.....	Med. Blue Cloth & Vinyl
7B.....	Med. Blue Vinyl
7D.....	Dk. Red Leather & Vinyl
7F.....	Med. Ginger Cloth & Vinyl
7F.....	Med. Ginger Vinyl
7F.....	Med. Brown Cloth & Vinyl
7G.....	Med. Ivy Green Vinyl
7G.....	Dk. Ivy Green Leather & Vinyl
7G.....	Med. Ivy Green Cloth & Vinyl
7W.....	White Leather & Vinyl
7Y.....	Lt. Nugget Gold Cloth & Vinyl
8A.....	Black Vinyl
8A.....	Black Knit & Pewter Vinyl
8A.....	Black Grain Leather
8A.....	Black Knit & Vinyl
8A.....	Black Grain Leather &/or Vinyl
8B.....	Med. Blue Knit & Vinyl
8B.....	Med. Blue Vinyl
8D.....	Dk. Red Vinyl
8D.....	Dk. Red Grain Leather
8D.....	Dk. Red Knit & Vinyl
8D.....	Dk. Red Grain Leather &/or Vinyl
8F.....	Med. Brown Vinyl
8F.....	Med. Ginger Grain Leather &/or Vinyl
8F.....	Med. Ginger Vinyl
8F.....	Med. Ginger Grain Leather
8F.....	Med. Ginger Knit & Vinyl
8G.....	Med. Ivy Green Knit & Vinyl
8G.....	Med. Ivy Green Vinyl
8W.....	White Vinyl With Black
8W.....	White Knit & Vinyl
8W.....	White Knit & Vinyl With Black
9A.....	Black Vinyl
9A.....	Black Cloth & Vinyl
9B.....	Med. Blue Vinyl
9B.....	Med. Blue Cloth & Vinyl
9D.....	Dk. Red Vinyl
9D.....	Dk. Red Cloth & Vinyl
9F.....	Med. Ginger Vinyl
9G.....	Med. Ivy Green Cloth & Vinyl
9G.....	Med. Ivy Green Vinyl
9K.....	Lt. Aqua Cloth & Vinyl
9Y.....	Lt. Nugget Gold Cloth & Vinyl
AA.....	White Vinyl With Black Vinyl
AA.....	Black Vinyl With Black Vinyl
AA.....	Black Cloth & Vinyl
AB.....	White Vinyl With Blue Vinyl
AB.....	Blue Cloth With Blue Vinyl
AD.....	White Vinyl
AD.....	Dk. Red Cloth & Vinyl
AE.....	Vermilion Cloth & Vinyl
AF.....	Med. Ginger Cloth & Vinyl
AF.....	White Vinyl With Ginger
AG.....	White Vinyl With Ivy Gold
AG.....	Med. Ivy Green Cloth & Vinyl

INTERIOR TRIM CODES-(continued)

Code	Trim Schemes
AK.....	Lt. Aqua Cloth & Vinyl
AP.....	Med. Grey Cloth & Vinyl
AY.....	Lt. Nugget Cloth & Vinyl
AZ.....	White With Tobacco
BA.....	Black Vinyl
BA.....	Black Cloth & Vinyl
BB.....	Lt. Blue Vinyl
BB.....	Med. Blue Vinyl
BD.....	Dk. Red Cloth & Vinyl
BE.....	Vermilion Vinyl
BF.....	Med. Ginger Vinyl
BG.....	Med. Ivy Green
BW.....	White Vinyl
BW.....	White Vinyl With Black
CA.....	Black Cloth & Vinyl
CA.....	Black Knit & Vinyl
CB.....	Med. Blue Knit & Vinyl
CB.....	Med. Blue Cloth & Vinyl
CD.....	Dk. Red Cloth & Vinyl
CD.....	Dk. Red Knit & Vinyl
CE.....	Vermilion Cloth & Vinyl
CF.....	Med. Ginger Cloth & Vinyl
CF.....	Med. Ginger Knit & Vinyl
CG.....	Med. Ivy Green Cloth & Vinyl
CY.....	Lt. Nugget Gold Cloth & Vinyl
DA.....	Black Cloth & Vinyl
DA.....	Black Vinyl
DB.....	Med. Blue Cloth & Vinyl
DB.....	Med. Blue Vinyl
DD.....	Dk. Red Cloth & Vinyl
DD.....	Dk. Red Vinyl
DE.....	Med. Ginger Cloth & Vinyl
DF.....	Med. Ginger Cloth & Vinyl
DG.....	Med. Ivy Green Cloth & Vinyl
DG.....	Med. Ivy Green Vinyl
DK.....	Lt. Aqua Blue Vinyl
DW.....	White Vinyl With Black
DY.....	Lt. Nugget Gold Cloth & Vinyl
DY.....	Lt. Nugget Gold Vinyl
EA.....	Black Cloth & Vinyl
EA.....	Black Knit & Vinyl
EA.....	White & Black Vinyl
EB.....	Med. Blue Knit & Vinyl
EB.....	Med. Blue Cloth & Vinyl
ED.....	Dk. Red Cloth & Vinyl
EF.....	Med. Ginger Cloth & Vinyl
EG.....	Dk. Ivy Green Knit & Vinyl
EG.....	Med. Ivy Green Cloth & Vinyl
EW.....	White Knit & Vinyl
EW.....	White w/Black Knit & Vinyl
EY.....	Lt. Nugget Gold Cloth & Vinyl
FA.....	Black Vinyl
FA.....	White Vinyl With Black
FA.....	White With Black Leather w/Vinyl
FB.....	Med. Blue Vinyl
FB.....	White Vinyl With Blue
FD.....	Dk. Red Vinyl
FD.....	White Vinyl With Red
FD.....	Dk. Red Cloth & Vinyl
FF.....	White Vinyl With Ginger
FF.....	Med. Ginger Vinyl
FG.....	Med. Ivy Green Vinyl
FG.....	White Vinyl With Dk. Ivy
FY.....	Lt. Nugget Gold Cloth & Vinyl
FZ.....	White Vinyl With Tobacco
GA.....	Black Vinyl
GB.....	Med. Blue Vinyl
GD.....	Dk. Red Vinyl
GF.....	Med. Ginger Vinyl
GF.....	Med. Brown Vinyl
GW.....	White Vinyl With Black
HA.....	Black Cloth & Vinyl
HA.....	Black Knit & Vinyl



**BUY IT NOW!**

**Click Here To Order**



**INTERIOR TRIM CODES (continued)**

Code	Trim Schemes
HB	Med. Blue Cloth & Vinyl
HD	Dk. Red Cloth & Vinyl
HG	Med. Green Cloth & Vinyl
HY	Lt. Nugget Gold Cloth & Vinyl
HY	Lt. Nugget Gold Knit & Vinyl
JA	Black Vinyl
JA	Black Knit & Vinyl
JB	Med. Blue Cloth & Vinyl
JB	Med. Blue Vinyl
JD	Dk. Red Vinyl
JF	Med. Ginger Vinyl
JG	Med. Ivy Green Vinyl
JW	White Vinyl
JW	White Knit & Vinyl
JW	White Vinyl W/Black
JY	Lt. Nugget Gold Vinyl
KA	Black Vinyl
KA	Black Knit & Vinyl
KA	Black Cloth & Vinyl
KA	Black Leather & Vinyl
KB	Med. Blue Cloth & Vinyl
KB	Dk. Blue Leather & Vinyl
KD	Dk. Red Cloth & Vinyl
KD	Dk. Red Leather & Vinyl
KF	Med. Ginger Leather & Vinyl
KG	Med. Ivy Green Cloth & Vinyl
KG	Dk. Ivy Green Leather & Vinyl
KK	Lt. Aqua Leather & Vinyl
KP	Med. Grey Leather & Vinyl
KW	White Knit & Vinyl With Black
KW	White Leather & Vinyl
KY	Lt. Nugget Leather & Vinyl
KY	Lt. Nugget Gold Vinyl
KY	Lt. Nugget Gold Knit & Vinyl
KY	Lt. Nugget Gold Cloth & Vinyl
KY	Lt. Gold Vinyl
KZ	Dk. Tobacco Cloth & Vinyl
KZ	Dk. Tobacco Leather & Vinyl
LE	Lt & Med. Beige Vinyl
MA	Black Vinyl
MA	Black & White Cloth & Black Vinyl
MB	Med. Blue Vinyl
MD	Dk. Red Vinyl
MD	Red & Black Cloth & Red Vinyl
MF	Med. Ginger Vinyl
NA	Black Vinyl
NA	Black Knit & Vinyl
NB	Med. Blue Vinyl
NF	Med. Ginger Knit & Vinyl
NY	Lt. Nugget Gold Vinyl
PA	Black Vinyl
PA	Black Cloth & Vinyl
PB	Lt. Blue Vinyl
PB	Lt. Blue Cloth & Vinyl
PD	Dk. Red Cloth & Vinyl
PF	Med. Ginger Cloth & Vinyl
PY	Lt. Nugget Gold Vinyl
PY	Lt. Nugget Gold Cloth & Vinyl
QA	Black Knit & Vinyl
QB	Med. Blue Knit & Vinyl
QD	Dk. Red Knit & Vinyl
QW	White Knit & Vinyl With Black
RA	Black Vinyl
RA	Black Grain Leather Vinyl
RA	Black Knit & Vinyl
RA	Black & White Cloth & Black Vinyl
RA	Med. Blue Vinyl

**INTERIOR TRIM CODES (continued)**

Code	Trim Schemes
RG	Med. Green Vinyl
RG	Med. Ivy Green Knit & Vinyl
RW	White Vinyl With Black
RW	White Knit & Vinyl With Black
RZ	Dk. Tobacco Leather & Vinyl
SA	Black Vinyl
SA	Black & White Cloth & Black Vinyl
SB	Med. Blue Vinyl
SD	Red & Black Cloth & Red Vinyl
SD	Dk. Red Vinyl
SF	Med. Ginger Vinyl
SG	Med. Ivy Green Vinyl
SW	White Vinyl With Black
TA	Black Cloth & Vinyl
TA	Black Knit & Vinyl
TA	Black & White Cloth & Black Vinyl
TB	Med. Blue Knit & Vinyl
TD	Dk. Red Cloth & Vinyl
TD	Dk. Red & Black Cloth & Dk. Red Vinyl
TD	Dk. Red Knit & Vinyl
TF	Med. Ginger Cloth & Vinyl
TF	Med. Brown Cloth & Vinyl
TG	Med. & Lt. Ivy Green Knit & Vinyl
TW	White Knit & Vinyl
TW	White With Black Knit & Vinyl
TY	Lt. Nugget Gold Knit & Vinyl
UA	Black Knit & Vinyl
UA	Black Vinyl
UA	Black Grain Leather
UB	Med. Blue Vinyl
UD	Dk. Red Grain Leather
UE	Vermilion Cloth & Vinyl
UF	Med. Ginger Cloth & Ginger Vinyl
UW	White Knit & Vinyl With Black
UW	White Vinyl
UY	Lt. Gold Vinyl
UY	Lt. Nugget Gold Knit & Vinyl
UY	Lt. Nugget Gold Vinyl
UZ	Dk. Tobacco Grain Leather
VA	Black Knit & Vinyl
VA	Black Vinyl
VB	Med. Blue Vinyl
VD	Dk. Red Cloth & Vinyl
VD	Dk. Red Vinyl
VF	Med. Brown Vinyl
VF	Med. Ginger Vinyl & Cloth
VF	Med. Ginger Vinyl
VF	Med. Ginger Knit & Vinyl
VG	Med. Ivy Green Vinyl
VW	White Vinyl
WA	Black Knit & Vinyl
WA	Black Vinyl
WA	Black Cloth & Vinyl
WB	Med. Blue Cloth & Vinyl
WD	Dk. Red Cloth & Vinyl
WF	Med. Ginger Cloth & Vinyl
WF	Med. Brown Cloth & Vinyl
WG	Med. Ivy Green Cloth & Vinyl
WW	White Knit & Vinyl With Black
WY	Lt. Nugget Gold Vinyl
WY	Lt. Nugget Gold Knit & Vinyl
YA	Black Knit & Vinyl
YA	Black Cloth & Vinyl
YB	Med. Blue Knit & Vinyl
YD	Dk. Red Knit & Vinyl
YF	Med. Ginger Knit & Vinyl
YG	Med. Ivy Green Cloth & Vinyl
YG	Med. Ivy Green Knit & Vinyl
YW	White Knit & Vinyl With Black
YY	Lt. Nugget Gold Cloth & Vinyl
ZA	Black Cloth & Vinyl
ZG	Dk. Ivy Green Cloth & Vinyl
ZG	Med. Green Cloth & Vinyl

**DATE CODES**

A number signifying the date precedes the month code letter. A second-year code letter will be used if the model exceeds 12 months.

Month	Code First Year	Code Second Year
January	A	N
February	B	P
March	C	Q
April	D	R
May	E	S
June	F	T
July	G	U
August	H	V
September	J	W
October	K	X
November	L	Y
December	M	Z

**DISTRICT CODES (DSO)**

Units built on a Domestic Special Order, Foreign Special Order, or other Special orders will have the complete order number in this space. Also to appear in this space is the two-digit code number of the District which ordered the unit. If the unit is a regular production unit, only the District code number will appear.

**FORD**

Code	District
11	Boston
13	New York
15	Newark
16	Philadelphia
17	Washington
21	Atlanta
22	Charlotte
24	Jacksonville
25	Richmond
28	Louisville
32	Cleveland
33	Detroit
35	Lansing
37	Buffalo
38	Pittsburgh
41	Chicago
43	Milwaukee
44	Twin Cities
46	Indianapolis
47	Cincinnati
51	Denver
53	Kansas City
54	Omaha
55	St. Louis
56	Davenport
61	Dallas
62	Houston
63	Memphis
64	New Orleans
65	Oklahoma City
71	Los Angeles
72	San Jose
73	Salt Lake City
74	Seattle
75	Phoenix
83	Government
84	Home Office Reserve
85	American Red Cross
89	Transportation Services
90-99	Export

**100% SATISFACTION GUARANTEED**

**BUY IT NOW!**

**Click Here To Order**

PayPal American Express Discover MasterCard VISA

LINCOLN-MERCURY

Code	District
11.....	Boston
15.....	New York
16.....	Philadelphia
17.....	Washington
21.....	Atlanta
22.....	Dallas
23.....	Jacksonville
26.....	Memphis
31.....	Buffalo
32.....	Cincinnati
33.....	Cleveland
34.....	Detroit
41.....	Chicago
42.....	St. Louis
46.....	Twin Cities
51.....	Denver
52.....	Los Angeles
53.....	Oakland
54.....	Seattle
84.....	Home Office Reserve
90.....	Export

FORD OF CANADA

Code	District
B1.....	Central
B2.....	Eastern
B3.....	Atlantic
I1 thru I7.....	Export
B4.....	Midwestern
B6.....	Western
B7.....	Pacific

Note: Canadian Lincoln-Mercury units use prefix "A" in place of "B"



**BUY IT NOW!**  
 Click Here To Order 







Wheels And Tires	GROUP <b>11</b>
------------------	--------------------

<b>PART 11-01</b>	<b>PAGE</b>	<b>PART 11-03</b>	<b>PAGE</b>
General Wheels and Tires Service .....	11-01-01	Tires .....	11-03-01
<b>PART 11-02</b>			
Wheels .....	11-02-01		

## PART 11-01 General Wheels and Tires Service

COMPONENT INDEX This Information Applies to All Models	All Models	COMPONENT INDEX This Information Applies to All Models	All Models
FRONT WHEEL BEARING MAINTENANCE	01-01	WHEEL BALANCING	01-01
TIRE INSPECTION	01-02	WHEEL INSPECTION	01-01

A page number indicates that the item is for the vehicle(s) listed at the head of the column.  
N/A indicates that the item is not applicable to the vehicle(s) listed.

### 1 COMMON ADJUSTMENTS AND REPAIRS

#### WHEEL BALANCING

See the instructions provided with the Rotunda Wheel Balancer.  
Make certain that the brakes are not dragging before attempting to spin the wheels. Push the brake shoes into the caliper to free the rotor.

### 2 CLEANING AND INSPECTION

#### WHEEL INSPECTION

Wheel hub nuts should be inspected and tightened to specification at pre-delivery. Loose wheel hub nuts may cause shimmy and vibration. Elongat-

drum and lumps of mud or grease can unbalance a wheel and tire.

Check for damage that would affect the runout of the wheels. Wobble or shimmy caused by a damaged wheel will eventually damage the wheel bearings. Inspect the wheel rims for dents that could permit air to leak from the tires.

#### FRONT WHEEL BEARING MAINTENANCE

Wheel bearings are adjustable to correct for bearing and spindle shoulder wear. Satisfactory operation and long life of bearings depend on proper adjustment and correct lubrication. **If bearings are adjusted too tightly, they will overheat and wear rapidly.** An

BUY IT NOW!

Click Here To Order

adjustment that is excessively loose will cause pounding and contribute to uneven tire wear, steering difficulties and inefficient brakes. The bearing adjustment should be checked at regular inspection intervals.

Front hubs and bearings should be cleaned, inspected and lubricated whenever the hubs are removed or at

the mileage/time periods indicated in the maintenance schedule.

New hub grease seals should be installed when the hub is removed. An imperfect seal may permit bearing lubricant to reach the brake linings resulting in faulty brake operation and necessitating premature cleaning or replacement of linings.

## TIRE INSPECTION

Incorrect wheel alignment can cause tire wear. Abnormal or excessive tire wear can also be caused by wheel/tire unbalance or incorrect tire pressure. Typical tire wear patterns are shown in Fig. 1.



**SATISFACTION  
100%  
GUARANTEED**

**BUY IT NOW!**

**Click Here To Order**

PayPal American Express Cards Discover NOW! PLUS MasterCard VISA

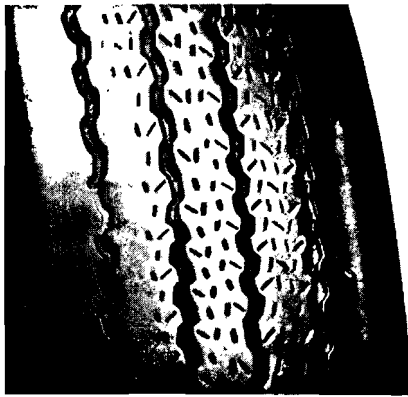

UNDERINFLATION

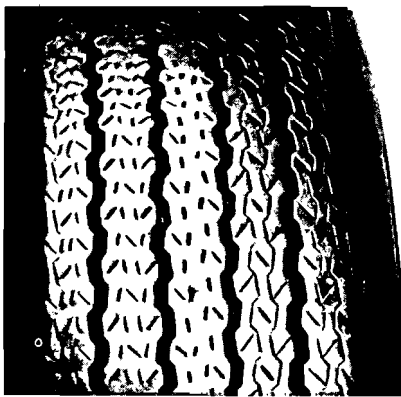

OVERINFLATION



CUPPING-UNDERINFLATION AND/OR MECHANICAL IRREGULARITIES



INCORRECT TOE-IN OR EXTREME CHAMBER

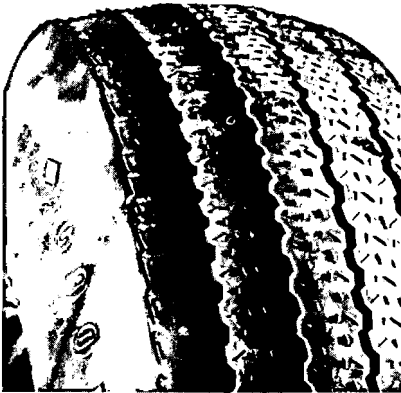

FEATHERING DUE TO MISALIGNMENT OR SEVERE CORNERING

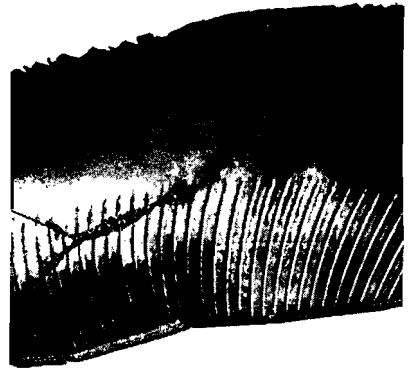

STONE BRUISE

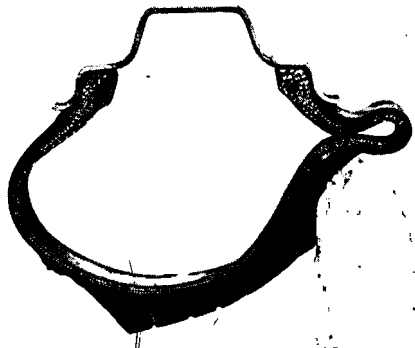

STONE BRUISE

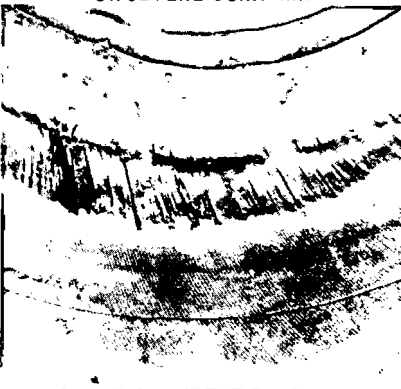

UNDERINFLATION

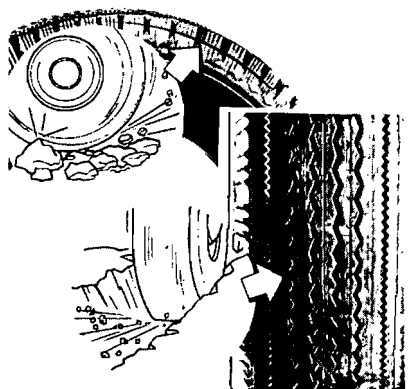

ROCK CUT

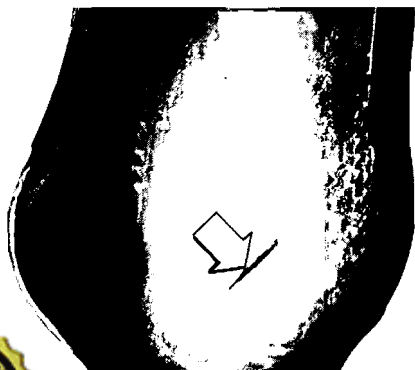

HEAT BRUISE

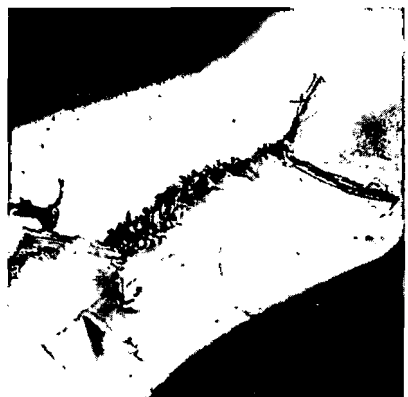
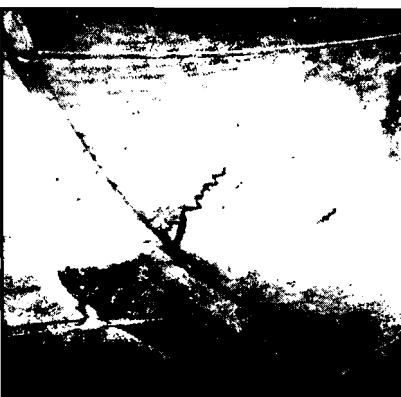

DOUBLE BRUISE-SHARP OBJECT AND RESULTING FATIGUE F1467-B



**BUY IT NOW!**

**Click Here To Order**



# PART 11-02 Wheels

COMPONENT INDEX Applies To Models As Indicated	All Models	Ford	Mercury	Meteor	Cougar	Fairlane	Falcon	Maverick	Montego	Mustang	Lincoln- Continental	Thunderbird	Continental- Mark III
FRONT HUB AND DRUM ASSEMBLY Removal and Installation	02-05												
FRONT HUB AND ROTOR ASSEMBLY Removal and Installation		02-05	02-05	02-05	02-05	02-05	02-05	N/A	02-05	02-05	02-05	02-05	02-05
FRONT WHEEL ASSEMBLY Description	02-01												
FRONT WHEEL BEARING ADJUSTMENT	02-02												
FRONT WHEEL GREASE SEAL AND BEARING Removal, Installation, Repacking	02-03												
HOISTING INSTRUCTIONS	02-02												
REAR WHEEL ASSEMBLY Description	02-01												
WHEEL AND TIRE (CONVENTIONAL) Removal and Installation	02-03												

A page number indicates that the item is for the vehicle(s) listed at the head of the column.  
N/A indicates that the item is not applicable to the vehicle(s) listed.

## 1 DESCRIPTION

### FRONT WHEEL ASSEMBLY

Each front wheel and tire is bolted to its respective front hub and brake drum or rotor assembly. Two opposed tapered roller bearings are installed in each hub. A grease retainer is installed at the inner end of the hub to prevent lubricant from leaking into the drum or on the rotor. The entire assembly is retained to its spindle by the adjusting nut, nut lock and cotter pin (Figs. 1 and 2).

### REAR WHEEL ASSEMBLY

The rear wheel hub and brake drum assembly is attached to studs on the rear axle shaft flange by three speed nuts. The wheel and tire mounts on the same rear axle shaft flange studs and is held against the hub and drum by the wheel nuts. The rear wheel bearing is pressed onto the axle shaft just inside the shaft flange, and the entire assembly is retained to rear axle housing by the bearing

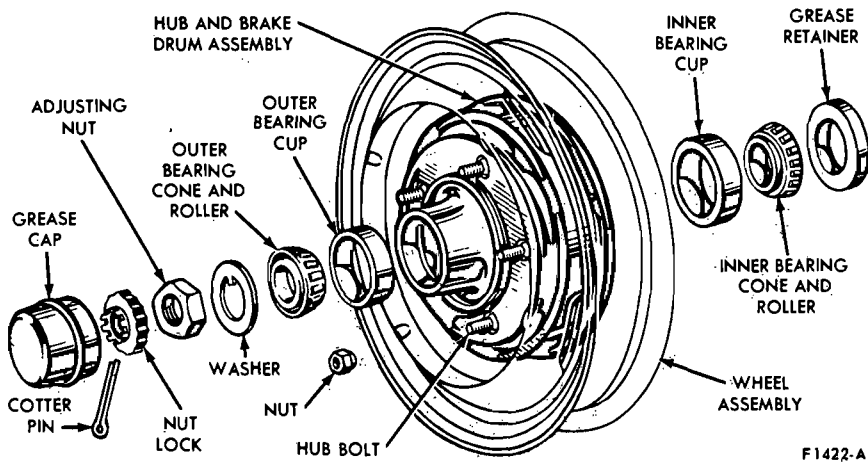
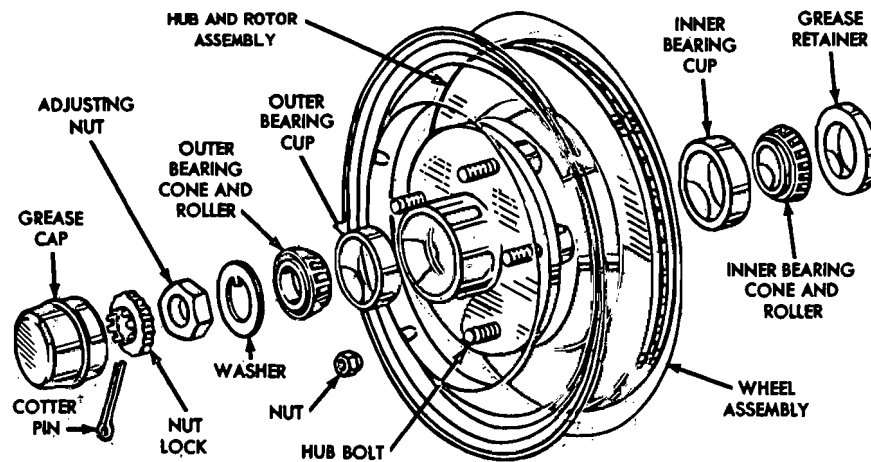

FIG. 1—Front Hub, Bearing and Grease Retainer Drum Brakes

**100% SATISFACTION GUARANTEED**

**BUY IT NOW!**

**Click Here To Order**



F1416-A

FIG. 2—Front Hub and Rotor Bearing and Grease Retainer Disc Brakes—Typical

## 2 IN-VEHICLE ADJUSTMENTS AND REPAIRS

### HOISTING INSTRUCTIONS

Damage to steering linkage components and front suspension struts may occur if care is not exercised when positioning the hoist adapters of 2 post hoists prior to lifting the vehicle.

If a 2 post hoist is used to lift the vehicle, place the adapters under the lower arms or the No. 1 crossmember. Do not allow the adapters to contact steering linkage. If the adapters are placed under the crossmember, a piece of wood (2x4x16 inches) should be placed on the hoist channel between the adapters. This will prevent the adapters from damaging the front suspension struts.

### FRONT WHEEL BEARING ADJUSTMENT

The front wheel bearings should be adjusted if the wheel is loose on the spindle or if the wheel does not rotate freely. The following procedures will bring the bearing adjustment to specification.

#### DRUM BRAKES

1. Raise the vehicle until the wheel and tire clear the floor.

2. Pry off the hub cap or wheel cover.

3. Remove the grease cap from the hub.

4. Wipe the excess grease from the end of the spindle, and remove the adjusting nut cotter pin and nut lock.

5. Loosen the bearing adjusting nut three turns. Then, rock the wheel, hub, and rotor assembly in and out several times to push the shoe and

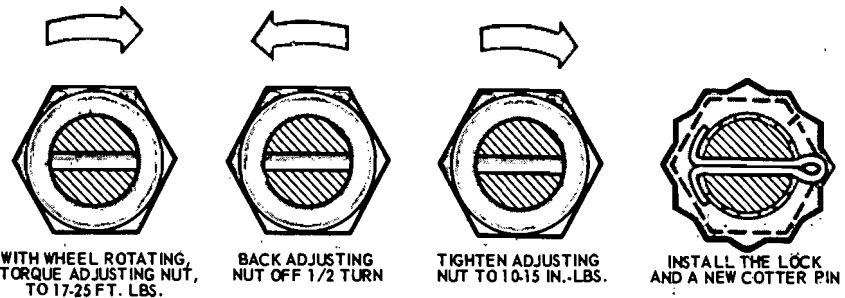

WITH WHEEL ROTATING, TORQUE ADJUSTING NUT, TO 17-25 FT. LBS.

BACK ADJUSTING NUT OFF 1/2 TURN

TIGHTEN ADJUSTING NUT TO 10-15 IN.-LBS.

INSTALL THE LOCK AND A NEW COTTER PIN

F1417-A

FIG. 3—Front Wheel Bearing Adjustment

end of the spindle, and remove the cotter pin and nut lock.

4. While rotating the wheel, hub, and drum assembly, torque the adjusting nut to 17-25 ft-lbs to seat the bearings (Fig. 3).

5. Locate the nut lock on the adjusting nut so that the castellations on the lock are aligned with the cotter pin hole in the spindle.

6. Using a 1 1/8-inch box wrench, back off the adjusting nut one half turn. Retighten the adjusting nut to 10-15 in-lbs with a torque wrench or finger tight.

7. Position the lock on the adjusting nut and install a new cotter pin. Bend the ends of the cotter pin around the castellated flange of the nut lock.

8. Check the front wheel rotation.

If the wheel rotates properly, install the grease cap and the hub cap or wheel cover. If the wheel still rotates roughly or noisily, clean, inspect or replace the bearings and cups as required.

#### DISC BRAKES

1. Raise the vehicle until the wheel and tire clear the floor.

2. Pry off the wheel cover and remove the grease cap (Fig. 2) from the hub.

3. Wipe the excess grease from the end of the spindle, and remove the adjusting nut cotter pin and nut lock.

4. Loosen the bearing adjusting nut three turns. Then, rock the wheel, hub, and rotor assembly in and out several times to push the shoe and

100% SATISFACTION GUARANTEED

**BUY IT NOW!**

Click Here To Order

PayPal, American Express, Discover, MasterCard, VISA

linings away from the rotor.

5. While rotating the wheel, hub, and rotor assembly, torque the adjusting nut to 17-25 ft-lbs to seat the bearings (Fig. 3).

6. Back the adjusting nut off one half turn. Then, retighten the adjusting nut to 10-15 in-lbs with a torque wrench or finger tight.

7. Locate the nut lock on the ad-

justing nut so that the castellations on the lock are aligned with the cotter pin hole in the spindle.

8. Install a new cotter pin, and bend the ends of the cotter pin around the castellated flange of the nut lock.

9. Check the front wheel rotation. If the wheel rotates properly, install

the grease cap and the hub cap or wheel cover. If the wheel still rotates roughly or noisily, clean or replace the bearings and cups as required.

10. Before driving the vehicle, pump the brake pedal several times to obtain normal brake lining to rotor clearance and restore normal brake pedal travel.

### 3 REMOVAL AND INSTALLATION

#### HOISTING INSTRUCTIONS

Damage to steering linkage components and front suspension struts may occur if care is not exercised when positioning the hoist adapters of 2 post hoists prior to lifting the vehicle.

If a 2 post hoist is used to lift the vehicle, place the adapters under the lower arms or the No. 1 crossmember. Do not allow the adapters to contact the steering linkage. If the adapters are placed under the crossmember, a piece of wood (2x4x16 inches) should be placed on the hoist channel between the adapters. This will pre-

vent the adapters from damaging the front suspension struts.

#### WHEELS AND TIRES

##### WHEEL AND TIRE REMOVAL

1. Pry off the wheel hub cap or wheel cover. Loosen but do not remove the wheel hub nuts.

2. Raise the vehicle until the wheel and tire clear the floor.

3. Remove the wheel hub nuts from the bolts, and pull the wheel and

tire from hub and drum.

##### WHEEL AND TIRE INSTALLATION

1. Clean all dirt from the hub and drum.

2. Position the wheel and tire on the hub and drum. Install the wheel hub nuts and tighten them alternately to draw the wheel evenly against the hub and drum.

3. Lower the vehicle to the floor, and torque the hub nuts to specification.

### 4 MAJOR REPAIR OPERATIONS

#### HOISTING INSTRUCTIONS

Damage to steering linkage components and front suspension struts may occur if care is not exercised when positioning the hoist adapters of 2 post hoists prior to lifting the vehicle.

If a 2 post hoist is used to lift the vehicle, place the adapters under the lower arms or the No. 1 crossmember. Do not allow the adapters to contact the steering linkage. If the adapters are placed under the crossmember, a piece of wood (2x4x16 inches) should be placed on the hoist channel between the adapters. This will prevent the adapters from damaging the front suspension struts.

eliminate looseness or rough and noisy operation, the hub and bearings should be cleaned, inspected, and repacked with specified wheel grease. If the bearing cups or the cone and roller assemblies are worn or damaged, they should be replaced.

#### DRUM BRAKES

1. Raise the vehicle until the wheel and tire clear the floor.

2. Remove the wheel cover or hub cap. Remove the grease cap from the hub. Remove the cotter pin, nut lock, adjusting nut, and flat washer from the spindle. Remove the outer bearing cone and roller assembly (Fig. 1).

3. Pull the wheel, hub, and drum assembly off the wheel spindle.

4. Remove the grease retainer with Tool 1175AB and discard. Remove the inner bearing cone and roller assembly from the hub.

5. Clean the lubricant off the inner

and outer bearing cups with solvent and inspect the cups for scratches, pits, excessive wear, and other damage. If the cups are worn or damaged, remove them with Tool T69L-1102-A (Fig. 4).

6. Thoroughly clean the inner and outer bearing cone and roller assemblies with solvent and dry them thoroughly. **Do not spin the bearings with compressed air.**

Inspect the cone and roller assemblies for wear or damage, and replace them if necessary. **The cone and roller assemblies and the bearing cups should be replaced as a unit if damage to either is encountered.**

7. Thoroughly clean the spindle and the inside of the hub with solvent to remove all old lubricant.

Cover the spindle with a clean cloth, and brush all loose dust and dirt from the brake assembly. **To prevent getting dirt on the spindle, carefully remove the cloth from the**

#### FRONT WHEEL GREASE SEAL AND BEARING REMOVAL, INSTALLATION AND/OR

**BUY IT NOW!**

**Click Here To Order**



spindle.

8. If the inner and/or outer bearing cup(s) were removed, install the replacement cup(s) in the hub with the tool shown in Fig. 5. **Be sure to seat the cups properly in the hub.**

9. Pack the inside of the hub with specified wheel bearing grease. Add lubricant to the hub only until the grease is flush with the inside diameter of both bearing cups (Fig. 6).

10. All old grease should be completely cleaned from the bearings and surrounding surfaces before repacking them with new grease (CIAZ-19590-B). The new lithium base grease is not compatible with sodium base grease which may have been present on the bearing surfaces. Pack the bearing cone and roller assemblies

with wheel bearing grease. A bearing packer is desirable for this operation. If a packer is not available, work as much lubricant as possible between the rollers and cages. Lubricate the cone surfaces with grease.

11. Place the inner bearing cone and roller assembly in the inner cup. Apply a light film of grease to the lip(s) of the grease retainer and install the new grease retainer with the reverse end of the tool shown in Fig. 5. **Be sure that the retainer is properly seated.**

12. Adjust the brake shoes as outlined in Group 12.

13. Install the wheel, hub, and drum assembly on the wheel spindle. **Keep the hub centered on the spindle to prevent damage to the grease retainer or the spindle threads.**

14. Install the outer bearing cone and roller assembly and the flat washer on the spindle, then install the adjusting nut (Fig. 1).

15. Adjust the wheel bearings as outlined in Section 2, and install a new cotter pin. Bend the ends of the cotter pin around the castellations of the nut lock to prevent interference with the radio static collector in the grease cap. Install the grease cap.

16. Install the hub cap or wheel cover.

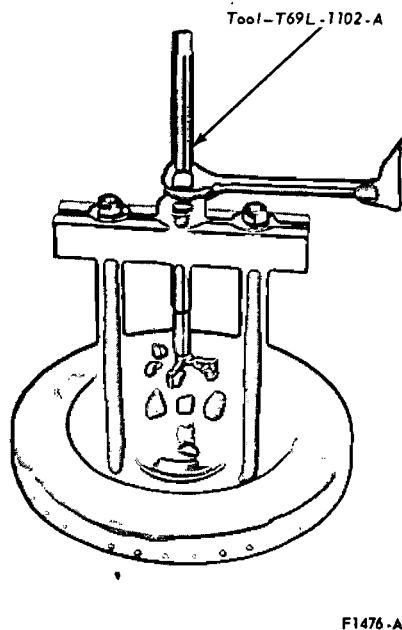
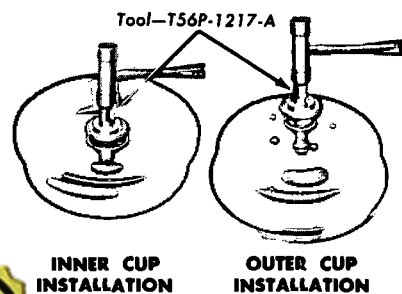

FIG. 4—Removing Front Wheel Bearing Cups—Disc (Drum-Type Similar)



## DISC BRAKES

1. Raise the vehicle until the wheel

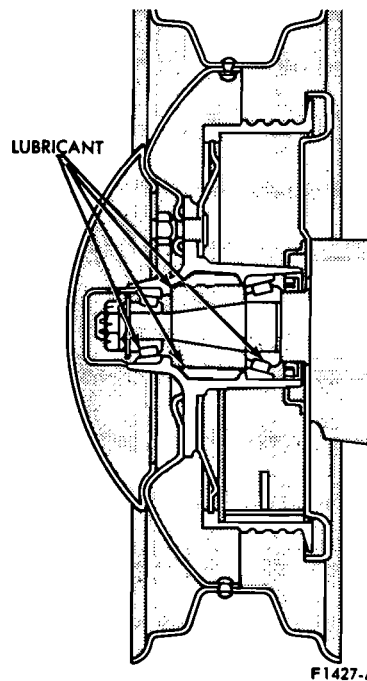

FIG. 6—Front Wheel Hub Lubrication

and tire clear the floor.

2. Remove the wheel cover or hub cap from the wheel.

3. Remove the wheel and tire from the hub and rotor.

4. Remove 2 bolts and washers that attach the caliper to the spindle. Remove the caliper from the rotor and wire it to the underbody to prevent damage to the brake hose.

5. Remove the grease cap from the hub. Remove the cotter pin, nut lock, adjusting nut, and flat washer from the spindle. Remove the outer bearing cone and roller assembly (Fig. 2).

6. Pull the hub and rotor assembly off the wheel spindle.

7. Remove and discard the old grease retainer and the inner bearing cone and roller assembly from the hub.

8. Clean the lubricant off the inner and outer bearing cups with solvent and inspect the cups for scratches, pits, excessive wear, and other damage. If the cups are worn or damaged, remove them with Tool T69L-1102-A (Fig. 4).

9. Thoroughly clean the inner and outer bearing cones and rollers with cleaning solvent, and dry them thoroughly. **Do not spin the bearings dry with compressed air.**

Inspect the cones and rollers for wear or damage, and replace them if necessary. The cone and roller assemblies and the bearing cups should be replaced as a set if damage to either is encountered.

10. Thoroughly clean the spindle and the inside of the hub with solvent to remove all old lubricant.

Cover the spindle with a clean cloth, and brush all loose dust and dirt from the dust shield. **To prevent getting dirt on the spindle carefully remove the cloth from the spindle.**

11. If the inner and/or outer bearing cup(s) were removed, install the replacement cup(s) in the hub with the tools shown in Fig. 7. **Be sure to seat the cups properly in the hub.**

12. Pack the inside of the hub with the specified wheel bearing grease. Add lubricant to the hub only until the grease is flush with the inside diameter of both bearing cups.

It is important that all old grease be removed from the wheel bearings and surrounding surfaces because the new Lithium base grease CIAZ-19590-B is not compatible with Sodium base grease which may already be present on the bearing surfaces.

13. Pack the bearing cone and roller assemblies with wheel bearing grease. A bearing packer is desirable

**100% SATISFACTORY GUARANTEED**

**BUY IT NOW!**

**Click Here To Order**

PayPal, American Express, Discover, MasterCard, VISA

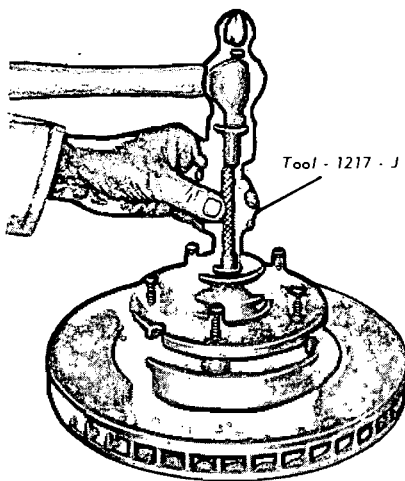
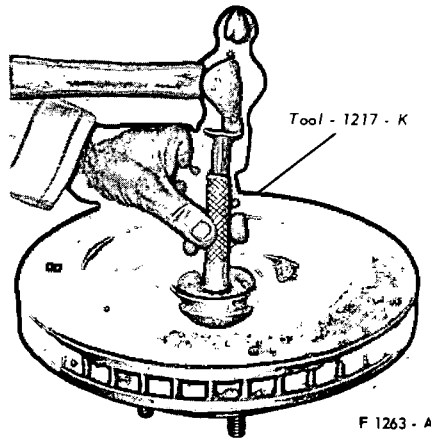
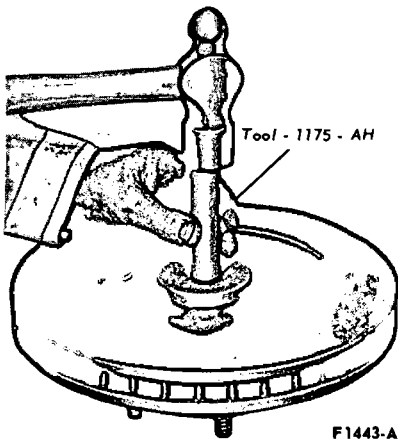

FIG. 7—Installing Front Wheel Bearing Cup—Disc



F 1263 - A



F1443-A

FIG. 8—Installing Grease Retainer—Disc

for this operation. If a packer is not available, work as much lubricant as possible between the rollers and cages. Lubricate the cone surfaces with grease.

14. Place the inner bearing cone and roller assembly in the inner cup. Apply a light film of grease to the lips of the grease retainer and install the new grease retainer with the tool shown in Fig. 8. **Be sure the retainer is properly seated.**

15. Install the hub and rotor assembly on the wheel spindle. **Keep the hub centered on the spindle to prevent damage to the grease retainer or the spindle threads.**

16. Install the outer bearing cone and roller assembly and the flat washer on the spindle, then install the ad-

new cotter pin. Bend the ends of the cotter pin around the castellations of the nut lock to prevent interference with the radio static collector in the grease cap. Install the grease cap.

18. Install the caliper to the spindle and torque the attaching bolts to specifications as detailed in Group 2.

19. Install the wheel and tire on the hub.

20. Install the hub cap or wheel cover.

21. Before driving the vehicle, pump the brake pedal several times to obtain normal brake lining to rotor clearance and restore normal brake pedal travel.

#### FRONT HUB AND DRUM ASSEMBLY REMOVAL AND INSTALLATION

When the hub and drum assembly is replaced, new bearings and a grease retainer must be installed in the new assembly. The new grease retainer should be soaked in light engine oil at least 30 minutes before installation.

1. Raise the vehicle until the wheel and tire clears the floor. Pry off the hub cap or wheel cover, and remove the wheel and tire from the hub and drum assembly.

2. Remove the grease cap from the hub. Remove the cotter pin, nut lock adjusting nut, and flat washer from the spindle. Remove the outer bearing cone and roller assembly (Fig. 1).

3. Pull the hub and drum assembly off the wheel spindle.

4. Remove the grease retainer and the inner bearing cone and roller assembly from the hub with Tool 1175AB.

5. Remove the protective coating

from the new hub and drum with carburetor degreaser.

6. Pack the inside of the hub with specified wheel bearing grease. Add lubricant to the hub only until the grease is flush with the inside diameter of both bearing cups (Fig. 6).

7. All old grease should be completely cleaned from the bearings before repacking them with new grease. Pack the bearing cone and roller assemblies with wheel bearing grease. A bearing packer is desirable for this operation. If a packer is not available, work as much lubricant as possible between the rollers and cages. Lubricate the cone surfaces with grease.

8. Place the inner bearing cone and roller assembly in the inner cup, and install the new grease retainer with the reverse end of the tool shown in Fig. 5. **Be sure that the retainer is properly seated.**

9. Adjust the brake shoes as outlined in Group 12.

10. Install the new hub and drum assembly on the wheel spindle. **Keep the hub centered on the spindle to prevent damage to the grease retainer.**

11. Install the outer bearing cone and roller assembly and the flat washer on the spindle; then, install the adjusting nut (Fig. 1).

12. Position the wheel and tire on the new hub and drum assembly. Install the wheel hub nuts and tighten them alternately in order to draw the wheel evenly against the hub and drum.

13. Adjust the wheel bearings as outlined in Section 2, and install a new cotter pin. Bend the ends of the cotter pin around the castellations of the nut lock to prevent interference with the radio static collector in the grease cap. Install the grease cap.

14. Install the hub cap or wheel cover.

#### FRONT HUB AND ROTOR ASSEMBLY REMOVAL AND INSTALLATION

When the hub and rotor assembly is replaced, new bearings and a grease retainer must be installed in the new assembly.

1. Raise the vehicle until the wheel and tire clear the floor. Pry off the hub cap or wheel cover, and remove the wheel and tire from the hub and rotor assembly.

2. Remove 2 bolts and washers that attach the caliper to the spindle. Remove the caliper from the rotor and wire it to the underbody to pre-



**BUY IT NOW!**

**Click Here To Order**



vent damage to the brake hose.

3. Remove the grease cap from the hub. Remove the cotter pin, nut lock, adjusting nut, and flat washer from the spindle; then, remove the outer bearing cone and roller assembly, (Fig. 2).

4. Pull the hub and rotor off the spindle.

5. Remove the protective coating from the new hub and rotor with carburetor degreaser.

6. Grease and install the inner bearing cone and roller assembly in the inner bearing cup. Apply a light film of grease on the grease retainer

and install the grease retainer.

7. Install the new hub and rotor assembly to the wheel spindle. **Keep the hub centered on the spindle to prevent damage to the grease retainer.**

8. Install the outer bearing cone and roller assembly and the flat washer on the spindle; then, install the adjusting nut.

9. Install the caliper to the spindle and tighten the attaching bolts to specifications as detailed in Group 12.

10. Position the wheel and tire on the new hub and rotor. Install the wheel hub nuts and tighten them alternately in order to draw the wheel

evenly against the hub and rotor.

11. Adjust the wheel bearings as outlined in Section 2, and install a new cotter pin. Bend the ends of the cotter pin around the castellations of the nut lock to prevent interference with the radio static collector in the grease cap. Install the grease cap.

12. Install the hub cap or wheel cover.

13. Before driving the vehicle, pump the brake pedal several times to obtain normal brake lining to rotor clearance and restore normal brake pedal travel.

## 5 SPECIAL SERVICE TOOLS

Tool No.	Description
1175-AB	Grease Seal Remover (Head Only)
T69L-1102-A	Front Wheel Bearing Remover

CF1540-A



# PART 11-03 Tires

COMPONENT INDEX Applies To Models As Indicated	All Models	Mercury	Meteor	Cougar	Fairlane	Falcon	Maverick	Mustang	Montego	Lincoln- Continental	Thunderbird	Continental- Mark III
HOISTING INSTRUCTIONS	03-01											
TIRES (CONVENTIONAL)												
Mounting	03-02											
Removal	03-02											
TIRES (LIFE GUARD)												
Balancing		N/A	N/A	N/A	N/A	N/A	N/A	N/A	N/A	03-01	03-01	03-01
Correcting Vibration and Shake		N/A	N/A	N/A	N/A	N/A	N/A	N/A	N/A	03-02	03-02	03-02
Description		N/A	N/A	N/A	N/A	N/A	N/A	N/A	N/A	03-01	03-01	03-01
Installation		N/A	N/A	N/A	N/A	N/A	N/A	N/A	N/A	03-03	03-03	03-03
Removal		N/A	N/A	N/A	N/A	N/A	N/A	N/A	N/A	03-03	03-03	03-03
Repairs		N/A	N/A	N/A	N/A	N/A	N/A	N/A	N/A	03-04	03-04	03-04

A page number indicates that the item is for the vehicle(s) listed at the head of the column.  
N/A indicates that the item is not applicable to the vehicle(s) listed.

## 1 DESCRIPTION

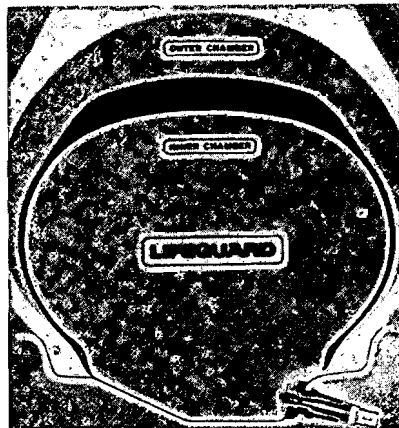

F 1380 - A

FIG. 1—Life Guard Safety Tire—Sectional View

### LIFE GUARD TIRE

The Goodyear Power Cushion Tire (available on Thunderbird, Lincoln and Continental Mark III models) fitted with the Life Guard Safety Spare provides a tire within a tire with two separate air chambers (Fig. 1). If the outer tire casing should be punctured or otherwise damaged causing it to go flat, the Life Guard Safety Spare will carry the load of the vehicle and will allow driving at speeds up to 40 mph with good control up to a distance of 40 miles. A Safety-Signal built into the Life Guard tread produces a lopsided vibration indicating the outer tire has lost pressure.

## 2 IN-VEHICLE ADJUSTMENTS AND REPAIRS

### HOISTING INSTRUCTIONS

vehicle, place the adapters under the lower arms or the No. 1 crossmember. Do not allow the adapters to contact steering linkage. If the adapters are placed under the crossmember, a piece of wood (2x4x16 inches) should be placed on the hoist channel between the adapters. This will prevent

the adapters from damaging the front suspension struts.

### BALANCING LIFE GUARD TIRE

Tires fitted with the Life Guard Safety Spare are balanced in the

**100% SATISFACTION GUARANTEED**

**BUY IT NOW!**

**Click Here To Order**

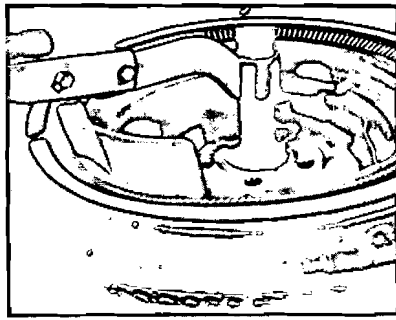

F 1383 - A

FIG. 2—Breaking Top Bead of Tire From Wheel Rim

same manner as conventional tires. If an excessive out of balance condition exists the following procedure can be used to correct the condition:

1. Remove the core housing and

deflate both air chambers.

2. Install the core housing.

3. Unseat the beads of tire with the bead breakers away from the valve stem as shown in Fig. 2.

4. Rotate tire casing 90 degrees on the wheel rim.

5. Rotate the tire casing back and forth on the rim to center the valve.

6. Inflate both chambers of the tire following steps 13 through 15 of the Tire Installation procedure.

7. Balance the tire in the normal manner.

### CORRECTING VIBRATION AND SHAKE— LIFE GUARD TIRE

The condition of excessive vibration and shake is generally the result of an

incorrect pressure relationship between the inner and outer air chambers that may cause the life guard to shift position within the tire. The following procedure should be used to correct vibration and shake conditions:

1. Check pressure of the inner and outer air chambers on all four tires.

2. If the inner chamber has at least five psi more pressure than the outer chamber the pressures should be adjusted and the tires rebalanced if necessary.

3. If the pressures of the inner and outer air chambers are equal the Air Container is leaking. To repair the leaking air container the recommended procedures for the removal, repair of air container, mounting, and balancing should be followed.

## 3 REMOVAL AND INSTALLATION

### HOISTING INSTRUCTIONS

Damage to steering linkage components and front suspension struts may occur if care is not exercised when positioning the hoist adapters of 2 post hoists prior to lifting the vehicle.

If a 2 post hoist is used to lift the vehicle, place the adapters under the lower arms or the No. 1 crossmember. Do not allow the adapters to contact the steering linkage. If the adapters are placed under the crossmember, a piece of wood (2x4x16 inches) should be placed on the hoist channel between the adapters. This will prevent the adapters from damaging the front suspension struts.

### REMOVING CONVENTIONAL TIRE FROM WHEEL

The tire can be demounted on a mounting machine. Be sure that the outer side of the wheel is positioned downward. If tire irons are used, follow the procedure given here.

1. Remove the valve cap and core, and deflate the tire completely.

2. With a bead loosening tool, break loose the tire side walls from the wheel (Fig. 3).

3. Position the outer side of the

tire irons with rounded edges or irons designed for removing tubeless tires.

4. Leave one tire iron in position, and pry the rest of the bead over the rim with the other iron. Take small bites with the iron around the tire in order to avoid damaging the sealing surface of the tire bead.

5. Stand the wheel and tire upright with the tire outer bead in the drop center well at the bottom of the wheel. Insert the tire iron between the bead and the edge of the wheel rim, and pry the wheel out of the tire.

### MOUNTING CONVENTIONAL TIRE TO WHEEL

1. If a used tire is being installed remove all dirt from the tire.

If a tire is being mounted to the original wheel, clean the rim with emery cloth or fine steel wool. Check the rim for dents.

If a new wheel is being installed, coat a new valve with RUGLYDE or similar rubber lubricant and position the valve to the new wheel. Use a rubber hammer or a valve replacing tool to seat the valve firmly against the inside of the rim.

2. Apply RUGLYDE or a similar rubber lubricant to the sealing surface on both tire beads. With the outer side of the wheel down, pry the beads over the wheel rim with two tire irons. Do not use a hammer or mallet

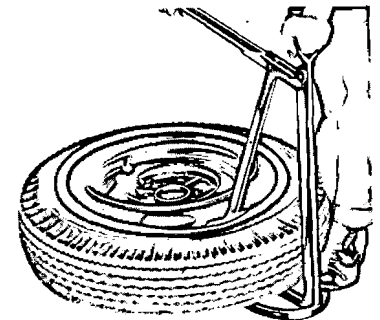

F1424 A

FIG. 3—Bead Loosening Tool

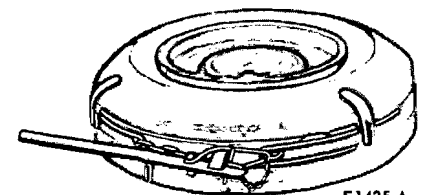

F1425-A

FIG. 4—Tubeless Tire Mounting Band

to force the beads over the rim.

3. Align the balance mark on the tire with the valve on the wheel.

4. Hold the beads against the rim flanges by positioning a tire mounting band over the tire (Fig. 4). If a mounting band is not available, tie a tourniquet of heavy cord around the circumference and in the center of the tire. Tighten the cord with a tire iron.

**100% SATISFACTION GUARANTEED**

**BUY IT NOW!**

**Click Here To Order**

PayPal   American Express   Discover   MasterCard   VISA

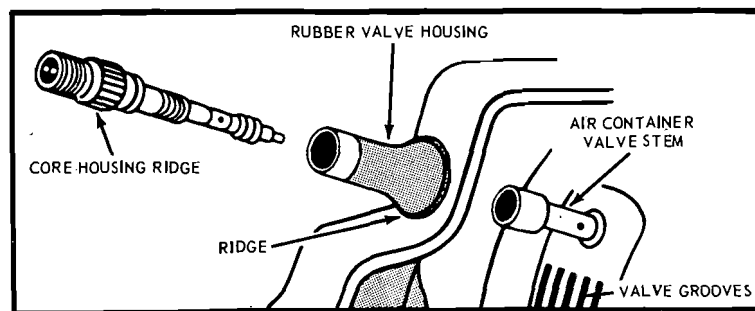

F 1382 - A

FIG. 5—Core Housing Disassembled

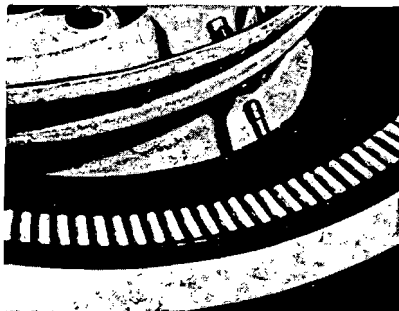

F 1384 - A

FIG. 6—Removing Air Container Valve Stem

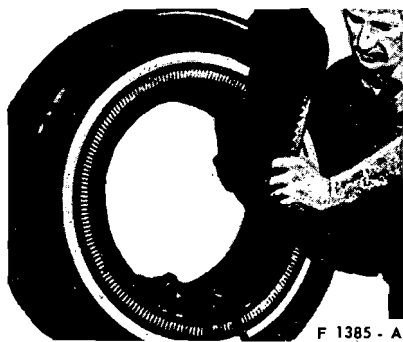

F 1385 - A

FIG. 7—Folding Life Guard For Installation in Tire



F 1386 - A

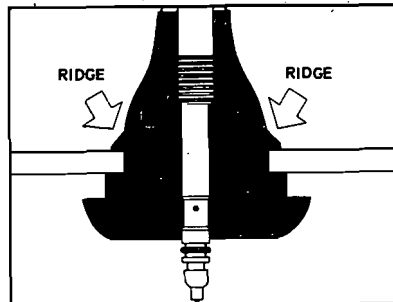

F 1387 - A

FIG. 9—Valve Installation

Center the tire on the wheel with a rubber mallet.

5. Give the tire a few quick bursts of air to seat the beads properly, then inflate the tire to 40 psi pressure. Check to see that the bead positioning rings (outer rings near the side walls) are evenly visible just above the rim flanges all the way around the tire. If the rings are not even, deflate the tire completely and inflate it again.

6. When the rings are properly positioned, deflate the tire to the recommended pressure.

#### REMOVING LIFE GUARD TIRE FROM WHEEL

1. Mark the valve stem location on the tire sidewall.

2. Remove the core housing (Fig. 5) and deflate both air chambers.

3. Unseat the beads of the tire with the bead breakers working away from the valve stem (Fig. 2).

4. Starting at the valve stem, work the top bead of the tire over the rim of the wheel.

5. Pull the air container valve stem out of the rubber valve housing (Fig. 6).

6. Remove the air container before attempting to remove the tire from the wheel.

7. Lift the lower bead over the wheel rim to remove the tire.

8. Remove the rubber valve housing from the wheel rim.

#### INSTALLING LIFE GUARD TIRE ON WHEEL

1. Apply Silicone Lubricant (COAZ-19553-A) as the anti-friction treatment uniformly over the crown and shoulder area inside the tire or outside the life guard.

2. Fold the life guard as shown in Fig. 7.

3. Insert life guard into tire casing.

4. Install a new rubber valve housing on the air container valve stem and thread the core housing into place. It is not necessary to install a new core housing.

5. Insert air container into the life guard with the valve grooves to the outboard side of the tire. Place the valve at the valve stem location marked on the sidewall during removal as shown in Fig. 8.

6. Apply a soap solution to the beads and the rubber valve housing.

7. Place the wheel on the mounting machine with the valve hole away from bead breakers. **Remove all burrs and sharp edges from valve hole in rim.**

8. Mount first tire bead exercising care not to pinch air container.

9. Start valve through hole in rim. **Do not pull valve housing into place at this time.**

10. Mount the second bead starting just past the valve so the last portion of the bead goes over the rim at the valve.

11. Rotate the tire back and forth to center the valve housing.

12. Pull the valve housing into place. Make certain that the rubber valve ridge is visible around the valve housing (Fig. 9).

13. Tighten the core housing lightly using pliers.

14. Thread the Inflate-Chek adapter onto the core housing.

15. Inflate the inner chamber to seat the tire beads exercising care not to exceed 45 psi pressure. Adjust this inner chamber air pressure to 15 psi higher than the recommended tire pressure.

16. Remove the Inflate-Chek adapter and adjust tire (outer chamber) pressure to the recommended pressure.

17. Recheck inner chamber pressure.

18. Install valve cap.

100% SATISFACTION GUARANTEED

**BUY IT NOW!**

Click Here To Order

PayPal | American Express | Discover | MasterCard | VISA

## 4 MAJOR REPAIR OPERATIONS

### HOISTING INSTRUCTIONS

Damage to steering linkage components and front suspension struts may occur if care is not exercised when positioning the hoist adapters of 2 post hoists prior to lifting the vehicle.

If a 2 post hoist is used to lift the vehicle, place the adapters under the lower arms or the No. 1 crossmember. Do not allow the adapters to contact the steering linkage. If the adapters are placed under the crossmember, a piece of wood (2x4x16 inches) should be placed on the hoist channel between the adapters. This will prevent the adapters from damaging the

front suspension struts.

### LIFE GUARD TIRE REPAIRS

#### REPAIR OF OUTER TIRE

##### Outside Repairs

All outside repairs are made in the same manner as on conventional tubeless tires.

##### Inside Repairs

1. Remove the anti-friction treatment on the inside of the tire with

rubber solvent.

2. Buff the inside area of the tire.
3. Apply a hot cure patch **only**.

#### REPAIR OF AIR CONTAINER

Air containers are repaired in the same manner as conventional inner tubes.

#### REPAIR OF LIFE GUARD

A damaged life guard that may pinch the air container should be replaced. No repairs are required for small punctures in the life guard.



Brakes	GROUP <b>12</b>
--------	--------------------

<b>PART 12-01</b> General Brake Service .....	<b>PAGE</b>	<b>PART 12-03</b> Disc Brakes .....	<b>PAGE</b>
	12-01-01		12-03-01
<b>PART 12-02</b> Drum Brakes .....	12-02-01	<b>PART 12-04</b> Parking Brakes .....	12-04-01

## Part 12-01 General Brake Service

COMPONENT INDEX Applies To Models As Indicated	All Models	Ford	Mercury	Meteor	Cougar	Fairlane	Falcon	Maverick	Montego	Mustang	Lincoln- Continental	Thunderbird	Continental- Mark III
<b>BRAKE BOOSTER</b>	01-08												
Adjustments	01-04												
Cleaning and Inspection	01-08												
Tests	01-02												
<b>BRAKE PEDAL</b>	01-02												
Free Height Test	01-02												
Total Travel Test	01-02												
<b>BRAKE PRESSURE DIFFERENTIAL AND/OR PRESSURE CONTROL VALVE</b>	01-06												
Centralizing	01-06												
<b>DISC BRAKES</b>	01-07												
Cleaning and Inspection	01-07												
Service Precautions	01-07												
<b>DRUM BRAKES</b>	01-08												
Cleaning and Inspection	01-08												
<b>HYDRAULIC LINES</b>	01-08												
Inspection	01-08												
Repair	01-08												
<b>HYDRAULIC SYSTEM BLEEDING</b>	01-05												
<b>PARKING BRAKE CONTROL</b>	01-02												
Vacuum Release Test	01-02												

A page number indicates that the item is for the vehicle(s) listed at the head of the column.  
N/A indicates that the item is not applicable to the vehicle(s) listed.

BUY IT NOW!

Click Here To Order

## 1 BRAKE SYSTEM TESTS

Always check the fluid level in the master cylinder before performing the test procedures. If the fluid level is not within 1/4 inch of the top of the master cylinder reservoirs, add Ford Brake Fluid - Extra Heavy Duty—Part Number C6AZ-19542-A (ESA-M6C25-A) or equivalent for all brake applications. The extra heavy duty brake fluid is colored blue for identification purposes. Do not mix low temperature brake fluids with the specified brake fluid.

Should one of the wheel brakes be locked and the vehicle must be moved, open the bleeder screw long enough to let out a few drops of brake fluid. This bleeding operation will release the brakes but will not correct the cause of trouble.

### BRAKE PEDAL FREE HEIGHT AND TRAVEL MEASUREMENTS

With the engine running for full power brake operation and the parking brake fully released, measure the brake pedal free height, and check the brake pedal travel with the use of the Brake Pedal Pressure Gauge, Tool WRE-500-50 as follows:

#### BRAKE PEDAL FREE HEIGHT MEASUREMENT

1. Insert a slender, sharp pointed prod through the carpet and sound deadener to the dash panel metal and measure the distance to the brake pedal (Fig. 1).

2. If the position of the pedal is not within specification, check the brake pedal linkage for missing, worn, or damaged bushings, or loose attaching bolts and replace them, if required.

3. If the pedal free height is still out of specification, check the brake pedal booster or master cylinder to be sure the correct parts are installed. Replace the worn or damaged parts as necessary.

#### BRAKE PEDAL TRAVEL MEASUREMENT

Install a Brake Pedal Effort

the brake pedal free height position to the reference point, which is at the six o'clock position on the steering wheel rim.

3. With the steel tape still hooked to the brake pedal depress the brake pedal by pressing downward on the brake pedal effort gauge. Apply a 50 pound load to the center of the pedal by observing the pressure gauge, and measure the distance from the brake pedal to the fixed reference point on the steering wheel rim parallel to the centerline of the steering column.

4. The difference between the brake pedal free height and the depressed pedal measurement under a 50 pound load should be within the specified maximum pedal travel service specification B in Fig. 1.

5. If the pedal travel is more than the specified maximum shown in Fig. 1, dimension C, make several sharp reverse stops (equivalent to 50 pounds pedal pressure) with a forward stop before each. Move the vehicle in reverse and forward for a distance of approximately ten feet; then, apply the brakes sharply and hold the brake pedal down until the vehicle is completely stopped. This will actuate the brake self-adjusters. If these stops do not bring the brake pedal travel within specification, make several additional forward and reverse stops as outlined above.

6. If the second series of stops do not bring the brake pedal travel within specification, remove the brake drums and check the brake adjusters to make sure they are functioning. Check the brake linings for wear or damage. Repair or replace all worn or damaged parts and non-functioning adjusters. Adjust the brake lining outside diameter to the approximate inside diameter of the brake drum with Rotunda Tool HRE-8650 described in Part 12-02.

7. If all the brake adjusters, brake drums and linings are functional and the brake travel is not within specifications, check the pedal linkage for missing or worn bushings, or loose attachments. Bleed the brakes and centralize the differential valve.

### POWER BRAKE FUNCTIONAL TEST

1. Check the hydraulic brake system for leaks or insufficient fluid.

2. With the transmission in neutral,

stop the engine and apply the parking brake. Depress the brake pedal several times to exhaust all vacuum in the system.

3. With the engine shut off and all vacuum in the system exhausted, depress the pedal, and hold it in the applied position. Start the engine. If the vacuum system is operating, the pedal will tend to fall away under foot pressure and less pressure will be required to hold the pedal in the applied position. If no action is felt, the vacuum booster system is not functioning.

If the brake pedal movement feels spongy, bleed the hydraulic system to remove air from the system. Refer to Hydraulic System Bleeding, in this Part.

### VACUUM TESTS—VACUUM RELEASE PARKING BRAKES

Visually check the operation of the brake linkage as the brake pedal is depressed. Then, check the operation of the brake linkage when the manual release lever is activated. These checks should indicate whether the manual parking brake control linkage is operating properly or requires repair or adjustment due to inability of the parking brake to hold against moderate vehicle movement. Perform tests of the parking brake system and controls after making certain the linkage, and manual controls operate properly.

When testing a parking brake vacuum, release system, a minimum of 10 inches of vacuum (Hg.) should be available at all points where vacuum is applied. This can be checked with a Rotunda Fuel Pump Tester Gauge (ARE345) and two Distributor Tester hose adapters (Marked Q) connected together with a coupling. This allows the Fuel Pump Tester Gauge hose to be adapted to any other vacuum hose or rubber connector in the vacuum systems.

Failure to maintain 10 inches of vacuum (Hg.) during vacuum system tests could be caused by a loose hose connection, resulting in a vacuum leak. When checking for vacuum between two points, trace the hose along the entire routing to be sure it is not crossed with another hose and connected to the wrong connection.

All of the vacuum parking brake control checks are to be performed with the engine running at idle speed.

100% SATISFACTION GUARANTEED

**BUY IT NOW!**

Click Here To Order

PayPal American Express Discover MasterCard VISA

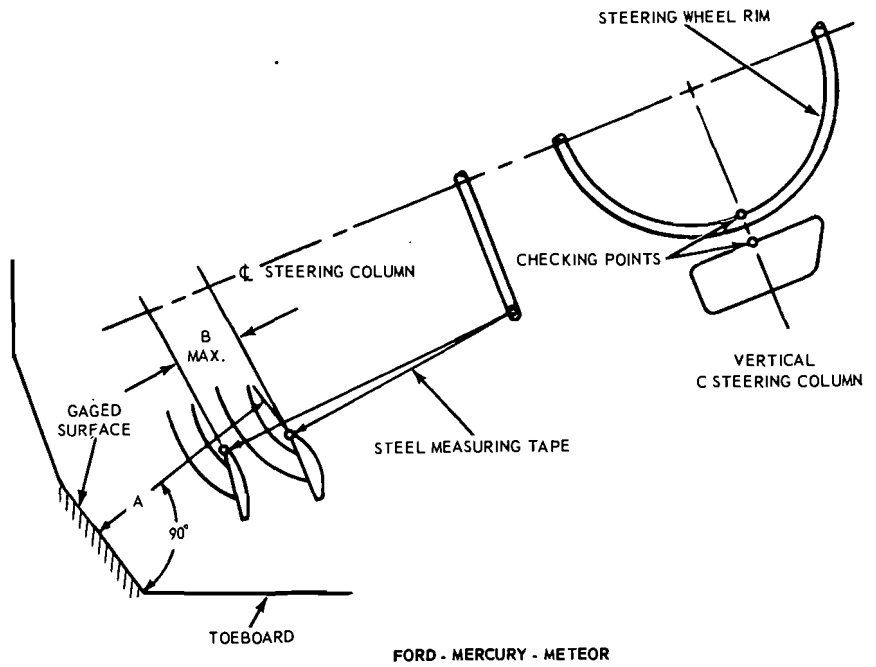
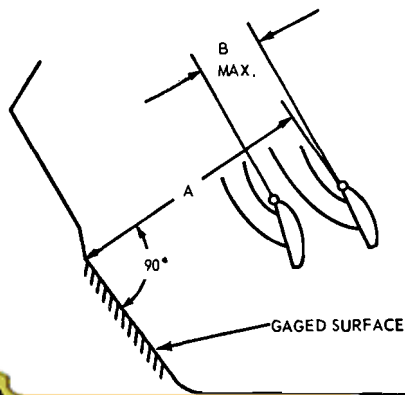
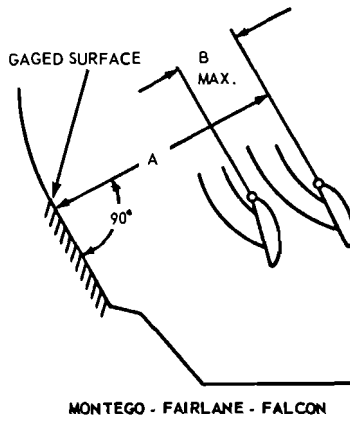
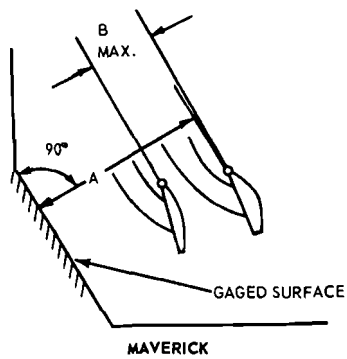
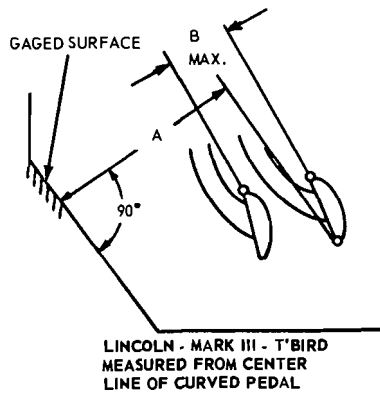

VEHICLE	TYPE	PEDAL FREE HEIGHT - A	PEDAL FREE HEIGHT - B	PEDAL TRAVEL - C
FORD, MERCURY AND METEOR	NON-POWER DRUM	8.09 - 7.17		3.10
FORD, MERCURY AND METEOR	POWER DRUM & DISC	6.78 - 5.99		3.27
FORD, MERCURY AND METEOR	NON-POWER DISC	8.65 - 7.82		2.18
FORD, MERCURY AND METEOR	POLICE POWER DISC	7.58 - 6.72		3.27
FAIRLANE AND MONTEGO	NON-POWER DRUM	8.32 - 7.02		2.90
FAIRLANE AND MONTEGO	POWER DISC	7.67 - 6.52		2.80
MUSTANG AND COUGAR	NON-POWER DRUM	7.49 - 6.43		2.58
MUSTANG AND COUGAR	POWER DISC	6.55 - 5.88		2.04
THUNDERBIRD	POWER DISC		6.87 - 5.77	3.35
CONTINENTAL MARK III	POWER DISC		6.87 - 5.77	3.35
LINCOLN CONTINENTAL	POWER DISC		7.39 - 6.62	3.27
MAVERICK	STD. DRUM	7.42	6.45	2.90
MONTEGO	POLICE DRUM	7.67	6.52	2.20
MONTEGO	POLICE DISC	8.40	7.25	2.80
FALCON	STD. DRUM	8.13	6.91	2.90

NOTE: A & B DIMENSION TO BE MEASURED TO SHEET METAL

C DIMENSION TO BE MEASURED PARALLEL TO THE VERTICAL CENTERLINE OF THE STEERING COLUMN WITH A 50 POUND LOAD APPLIED TO THE CENTERLINE OF THE BRAKE PEDAL PAD. (CHECKS ON POWER BRAKE VEHICLES MADE WITH ENGINE RUNNING)

**100% SATISFACTION GUARANTEED**

**BUY IT NOW!**

**Click Here To Order**

PayPal, American Express, Discover, MasterCard, VISA

pedal Travel Measurements

Tool—WRE-500-50

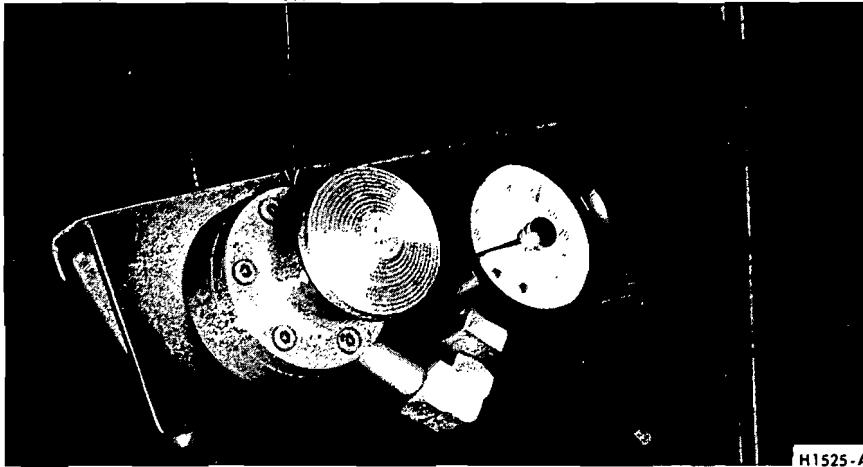

H1525-A

FIG. 2—Brake Pedal Effort Gauge Installed

Leaks in the parking brake hoses or a disconnected or improperly connected hose can usually be found by listening for a hissing sound along the hose routings. **Under no circumstances should air pressure be applied to the vacuum system as the actuator diaphragm in the parking brake vacuum motor may be damaged.**

1. Start the engine and run it at idle speed. With the transmission shift control in neutral, depress the parking brake pedal to apply the parking brake. Move the transmission shift control to D range and observe the

parking brake pedal to see that the pedal moves upward and the parking brake releases. If the parking brake releases, the parking brake vacuum control is working properly.

2. If the parking brake does not release, test for vacuum at the back-up light switch mounted on the steering column and the vacuum lines to the parking brake release vacuum motor. Use the Rotunda Vacuum and Fuel Pump Tester 345. This can be accomplished by removing the hose from each component and attaching it to

the vacuum gauge. Connect two distributor tester vacuum hose adapters together with a coupling as a connector to attach the gauge. A minimum of ten inches of vacuum is required to actuate the parking brake vacuum motor. If a minimum reading is not present when checking each of the aforementioned components, they must be replaced.

## PARKING BRAKE OPERATION

Check the operation of the parking brake. With the vehicle on a hoist and the parking brake fully released, the cables should not have any slack. Also, the rear brakes should not drag when the wheels are turned. If either of the above conditions exist, adjust as required.

## ROAD TEST

**A road test should be conducted only when the operator is sure the brakes will stop the vehicle.**

If the road test reveals one or more problem conditions, correct all malfunctions of the vacuum system, brake booster and hydraulic system prior to removing brake drums, brake calipers, brake shoes and linings or backing plates.

## 2 COMMON ADJUSTMENTS AND REPAIRS

### POWER BRAKE MASTER CYLINDER PUSH ROD ADJUSTMENT

The push rod is provided with an adjustment screw to maintain the correct relationship between the booster control valve plunger and the master cylinder. If the plunger is too long it will prevent the master cylinder piston from completely releasing hydraulic pressure and can cause the brakes to drag. If the plunger is too short it will result in excess pedal travel and an undesirable clunk in the booster area.

The adjustment screw is set to the correct height at the time of original assembly of the power unit. Under

ment is necessary, the push rod length may be verified with a push rod length gauge and measured with the engine running to apply vacuum to the booster (Fig. 3).

The push rod length verification and adjustment of Midland-Ross power brake booster assemblies must be done according to the following procedure:

1. Disconnect the master cylinder from the booster assembly and secure it away from the booster without disconnecting the brake tubes.

2. Reinstall the air filter assembly on the booster if it was removed with the master cylinder (Fig. 4).

3. Install and tighten the master cylinder retaining nuts to retain the air filter assembly securely against the booster body and to seal the booster bellows against air leaks.

4. Place the gauge against the

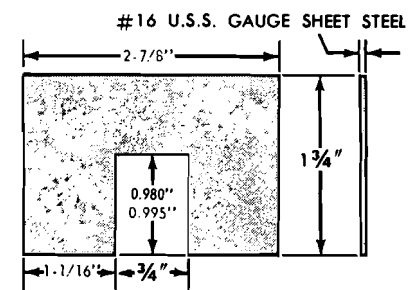

H1087-E

FIG. 3—Push Rod Gauge Dimensions

master cylinder mounting surface of the air filter assembly.

5. Adjust the push rod screw to provide a slight tension against the inner edge of the adjustment gauge slot. (Approximately 5 pounds of ten-

**100% GUARANTEED**

**BUY IT NOW!**

**Click Here To Order**

PayPal    American Express    Discover    MasterCard    VISA

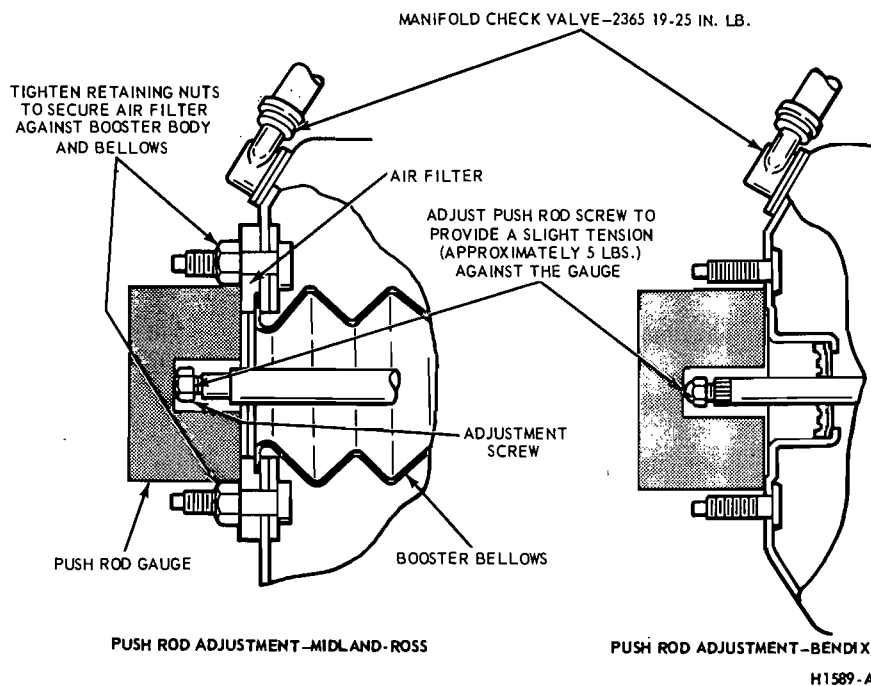

FIG. 4—Brake Booster Push Rod Measurement

sion against the push rod is required to assure that the push rod is firmly seated in the booster assembly).

6. Remove the retaining nuts from the booster master cylinder mounting studs.

7. Install the master cylinder on the brake booster and tighten the retaining nuts to the specified torque.

The push rod length verification of the Bendix power brake booster assemblies is accomplished as follows:

1. Disconnect the master cylinder from the booster assembly and secure away from the booster without disconnecting the brake tubes.

2. Adjust the push rod screw to provide a slight tension against the inner edge of the adjustment gauge slot. (Approximately 5 pounds of tension against the push rod is required to assure that the push rod is firmly seated in the booster assembly). See Figure 4.

3. Install the master cylinder on the brake booster and tighten the retaining nuts to the specified torque.

Do not set up side forces on the push rod as it may break the valve plunger.

This is an approximate adjustment only. To verify the adjustment, look through the make-up (rear) port of the master cylinder when installing

## HYDRAULIC SYSTEM BLEEDING

When any part of the hydraulic system has been disconnected for repair or replacement, air may enter the system and cause spongy pedal action. Bleed the hydraulic system after it has been properly connected, to be sure that all air is expelled.

### MANUAL BLEEDING

The Ford, Mercury, Meteor, Continental Mark III, Lincoln Continental, Thunderbird models equipped with disc brakes must be bled with pressure bleeding equipment.

The primary and secondary (front and rear) hydraulic brake systems are individual systems and are bled separately. Bleed the longest line first on the individual system being serviced. During the complete bleeding operation, DO NOT allow the reservoir to run dry. Keep the master cylinder reservoirs filled with Ford Fluid—Extra Heavy Duty—Part Number C6AZ-19542-A (ESA-M6C 25-A). The extra heavy duty brake fluid is colored blue for identification purposes. Do not mix low temperature brake fluids with the specified fluid during the bleeding operations. Never re-use brake fluid which has been drained from the hydraulic systems.

1. If the master cylinder is equipped with a bleed screw, loosen the bleed screw. Push the brake pedal

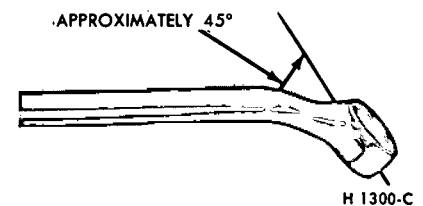

FIG. 5—Wrench for Bleeding Brake Hydraulic System

down slowly through its full travel. Close the bleeder fitting and return the pedal to the fully released position. Repeat this operation until fluid is free of air bubbles, then tighten the bleeder screw. Do not use the secondary piston stop screw, located on the bottom of the master cylinder to bleed the brake system. Loosening or removing this screw could result in damage to the secondary piston or stop screw.

2. To bleed the secondary (rear) brake system, position a suitable 3/8 inch box wrench (Fig. 5) on the bleeder fitting on the brake wheel cylinder. Attach a rubber drain tube to the bleeder fitting. The end of the tube should fit snugly around the bleeder fitting.

3. Submerge the free end of the tube in a container partially filled with clean brake fluid, and loosen the bleeder fitting approximately 3/4 turn.

4. Push the brake pedal down slowly through its full travel. Close the bleeder fitting, then return the pedal to the full-released position. Repeat this operation until air bubbles cease to appear at the submerged end of the bleeder tube.

5. When the fluid is completely free of air bubbles, close the bleeder fitting and remove the bleeder tube.

6. Repeat this procedure at the brake wheel cylinder on the opposite side. Refill the master cylinder reservoir after each wheel cylinder is bled and install the master cylinder cover and gasket. Be sure the diaphragm type gasket is properly positioned in the master cylinder cover. When the bleeding operation is completed, the fluid level should be filled to within 1/4 inch of the top of the reservoirs.

7. If the primary (front brake) system is to be bled. Repeat steps 2 through 6 at the right front brake caliper or cylinder and ending at the left front brake caliper or cylinder.

8. On disc brake equipped models be sure that the front brake pistons are returned to their normal positions and that the shoe and lining assemblies are properly seated by depress-

100% SATISFACTION GUARANTEED

**BUY IT NOW!**

Click Here To Order

PayPal American Express Discover NOWUS MasterCard VISA

ing the brake pedal several times until normal pedal travel is established.

9. Centralize the pressure differential valve. Refer to centralizing the Pressure Differential Valve procedures.

### PRESSURE BLEEDING ALL MODELS

Bleed the longest lines first. The bleeder tank should contain enough new Ford Brake Fluid to complete the bleeding operation. Use Ford Brake Fluid — Extra Heavy Duty — Part Number C6AZ-19542-A (ESA-M6C25-A) or equivalent for all brake applications. The brake fluid is colored blue for identification purposes. Do not mix low temperature brake fluid with the specified brake fluid during the bleeding operations. Never re-use brake fluid that has been drained from the hydraulic system. The tank should be charged with approximately 10 to 30 pounds of air pressure. Never exceed 50 pounds pressure.

1. Clean all dirt from the master cylinder reservoir cover.

2. Remove the master cylinder reservoir cover and rubber gasket, and fill the master cylinder reservoir with

the specified brake fluid. Install the pressure bleeder adapter tool to the master cylinder, and attach the bleeder tank hose to the fitting on the adapter.

Master cylinder pressure bleeder adapter tools can be obtained from the various manufacturers of pressure bleeding equipment. Follow the instructions of the manufacturer when installing the adapter.

3. If the master cylinder is equipped with a bleed screw, loosen the bleed screw and bleed the master cylinder until the fluid is free of air bubbles; then, tighten the bleed screw. Do not use the secondary piston stop screw, located on the bottom of the master cylinder, to bleed the master cylinder.

4. If the rear wheel cylinders, the secondary brake system, are to be bled, position a 3/8 inch box wrench (Fig. 5) on the bleeder fitting on the right rear brake wheel cylinder. Attach a bleeder tube to the bleeder fitting. The end of the tube should fit snugly around the bleeder fitting.

5. Open the valve on the bleeder tank to admit pressurized brake fluid to the master cylinder reservoir.

6. Submerge the free end of the tube in a container partially filled

with clean brake fluid, and loosen the bleeder fitting.

7. When air bubbles cease to appear in the fluid at the submerged end of the bleeder tube, close the bleeder fitting and remove the tube.

8. Repeat steps 3 through 7 at the left rear wheel cylinder.

9. If the vehicle is equipped with disc brakes, repeat steps 4 through 7, starting at the right front disc caliper and ending at the left front disc caliper.

On Ford, Mercury, Meteor, Continental Mark III, Lincoln Continental and Thunderbird models the metering valve release rod must be pulled outward and held a minimum of 1/16 inch (Fig. 6) while bleeding the primary brake system.

10. If the vehicle contains drum-type front brakes and the primary (front) brake system is to be bled, repeat steps 4 through 7, starting at the right front wheel cylinder ending at the left front wheel cylinder.

11. When the bleeding operation is completed, close the bleeder tank valve and remove the tank hose from the adapter fitting.

12. On disc brake equipped vehicles, be sure that the front brake pistons are returned to their normal positions and that the shoe and lining assemblies are properly seated by depressing the brake pedal several times until normal pedal travel is established.

13. Remove the Pressure Bleeder Adapter Tool. Fill the master cylinder reservoirs to within 1/4 inch of the top. Install the master cylinder cover and gasket. Be sure the Diaphragm type gasket is properly positioned in the master cylinder cover.

14. Centralize the pressure differential valve. Refer to Centralizing the Pressure Differential Valve procedures.

### CENTRALIZING THE PRESSURE DIFFERENTIAL AND/OR PRESSURE CONTROL VALVE

After any repair or bleeding of the primary (front brake) or secondary (rear brake) system, the dual-brake warning light will usually continue to be illuminated due to the pressure differential valve remaining in the off-center position.

To centralize the pressure differential valve and turn off the warning light after a repair operation:

1. Turn the ignition switch to the ACC or ON position.

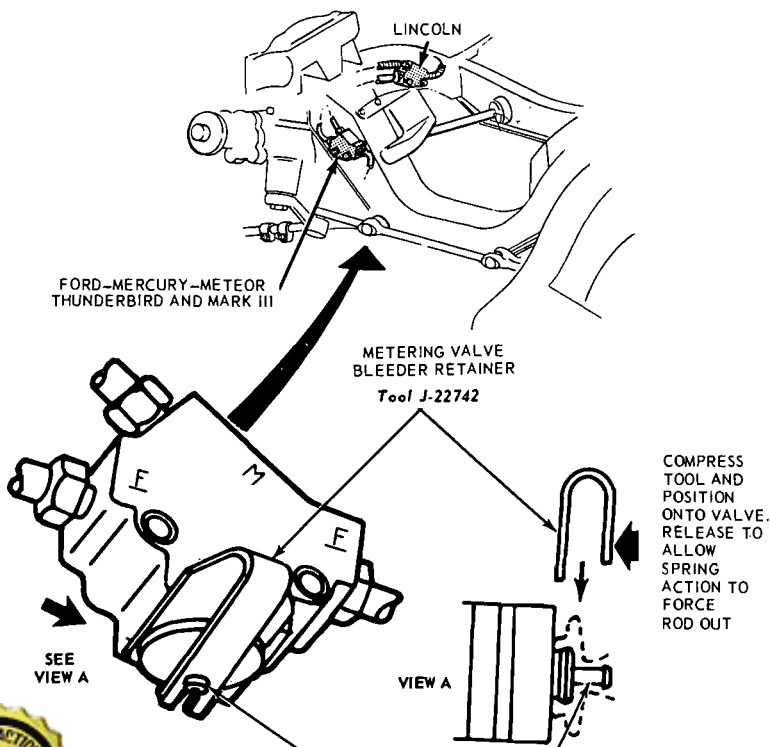

H1644.B

—Ford, Mercury, Meteor, Lincoln and Thunderbird

**100% SATISFACTION GUARANTEED**

**BUY IT NOW!**

**Click Here To Order**

PayPal, American Express, Discover, MasterCard, VISA

2. Check the fluid level in the master cylinder reservoirs and fill them to within 1/4 inch of the top with the specified brake fluid, if necessary.

3. Depress the brake pedal and the piston will center itself causing the brake warning light to go out.

4. Turn the ignition switch to the OFF position.

5. Before driving the vehicle, check

repaired or bled last.

1. Turn the ignition switch to the ACC or ON position. Loosen the differential valve assembly brake tube nut at the outlet port on the opposite side of the brake system that was wheel balanced, repaired and/or bled last. Depress the brake pedal slowly to build line pressure until the pressure differential valve is moved to a centralized position and the brake

warning light goes out; then, immediately tighten the outlet port tube nut.

2. Check the fluid level in the master cylinder reservoirs and fill them to within 1/4 inch of the top with the specified brake fluid, if necessary.

3. Turn the ignition switch to the OFF position.

4. Before driving the vehicle, check the operation of the brakes and be sure that a firm pedal is obtained.

### 3 CLEANING AND INSPECTION

#### DISC BRAKES

1. Remove the wheel and tire and the shoe and lining assemblies as outlined in Part 12-03.

2. On all models make the thickness measurements with a micrometer across the thinnest section of the shoe and lining. If the assembly has worn to a thickness of 0.230-inch (shoe and lining together) or 0.030-inch (lining material only) at any one of three measuring locations or if there is more than 0.125 taper from end to end or if lining shows evidence of brake fluid contamination, replace all (4) shoe and lining assemblies on both front wheels.

3. Check the caliper to spindle attaching bolts torque. Torque them to specification, if required.

4. To check rotor runout, first eliminate the wheel bearing end play by tightening the adjusting nut. After tightening the nut, check to see that the rotor can still be rotated.

5. Clamp a dial indicator to the caliper housing so that the pointer contact the rotor at a point approximately 1 inch from the outer edge. Rotate the rotor and take an indicator reading. If the reading exceeds 0.003 inch on custom vehicles and 0.002 inch on light vehicles total lateral runout on the indicator, replace or resurface the disc brake rotor. The following requirement must be met when resurfacing disc brake rotors:

Rotunda Disc Brake Attachment FRE-2249-2 is the **only approved** tool to be used to refinish the disc brake rotors. The step-by-step resurfacing procedure provided with the tool must

and 0.002 inch on light vehicles total indicator reading, braking surface are to be 80/15 micro inches.

On all models the minimum limiting dimension from the inboard bearing cup to the inboard rotor face and the minimum rotor thickness dimension, must be observed when removing material from the rotor braking surfaces. A ball and gage bar (Rotunda Kit FRE-70160) is to be used when checking minimum dimensions (Fig. 7).

When the runout check is finished be sure to adjust the bearings as outlined in Group 11-02 in order to prevent bearing failure.

6. Check the rotor for scoring. Minor scores can be removed with a fine emery cloth. If the rotor is excessively scored, refinish it as outlined in step 5 or replace the rotor, if required.

7. Visually check the caliper. If the caliper housing is leaking it should be replaced. If a seal is leaking the caliper must be disassembled and new seals installed. If a piston is seized in the bore a new caliper housing is required.

Check the brake hoses for signs of cracking, leaks or abrasion. Replace them if necessary.

#### DISC BRAKE SERVICE PRECAUTIONS

1. Grease or any other foreign material must be kept off the caliper assembly, surfaces of the rotor and external surfaces of the hub during service operations. Handling of the rotor and caliper assemblies should be done in a way to avoid deformation of the brake rotor and nicking or scratching of brake linings.

2. If a caliper piston is removed for

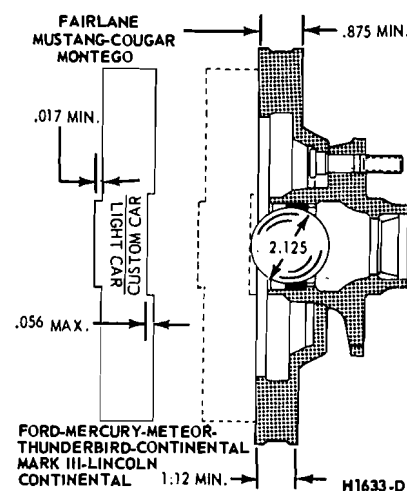

FIG. 7—Disc Brake Rotor Service Limits—All Models

any reason, the piston seal must be replaced.

3. During removal and installation of a wheel assembly, exercise care not to interfere with and damage the caliper splash shield or the bleeder screw fitting.

4. Front wheel bearing end play is critical and must be within specifications.

5. Be sure the vehicle is centered on the hoist before servicing any front end components, to avoid bending or damaging the rotor splash shield on full right or left wheel turns.

6. Riding of the brake pedal (common on left foot applications) should be avoided during vehicle operation.

7. The wheel and tire must be removed separately from the brake rotor, unlike drum brakes where the wheel, tire and drum are removed as a unit.

8. On floating caliper type disc brakes whenever the caliper is removed the caliper locating pins should



**BUY IT NOW!**

**Click Here To Order**



be inspected for wear or damage.

9. On floating caliper type disc brakes, the caliper assembly must be removed from the spindle prior to removal of the shoe and lining assemblies.

10. On floating caliper type disc brakes the calipers must not be interchanged from one side to the other. When the caliper is installed on its proper anchor plate and spindle, the bleeder screw will point to the rear of the vehicle. If a caliper is installed on the wrong side of the vehicle, it is not possible to bleed the system properly.

11. Do not attempt to clean or restore oil or grease soaked brake linings. When contaminated linings are found, brake linings must be replaced in complete axle sets.

### DRUM BRAKES

1. Remove the wheel from the drum, and remove the drum as outlined in Part 12-02.

2. Brush all dust from the backing plates and interior of the brake drums.

3. Inspect the brake shoes for excessive lining wear or shoe damage. If the lining is worn within 1/32 inch of the rivet heads or if the shoes are damaged, they must be replaced. Replace any lining that had been contaminated with oil, grease or brake fluid. Replace lining in axle sets. Prior to replacement of lining, the drum diameter should be checked to determine if oversize linings must be installed.

4. Check the condition of brake shoes, retracting springs, hold-down springs, and drum for signs of overheating. If the shoes have a slight blue coloring, indicating overheating,

replacement of the retracting and hold-down springs is strongly recommended. **Overheated springs lose their pull and could cause the new lining to wear prematurely, if they are not replaced. If the brake drums are heat spotted, indicating a overheated condition, they should be replaced.**

5. If the vehicle has 30,000 or more miles of operation on the brake linings or signs of overheating are present when relining brakes, the wheel cylinders should be disassembled and inspected for wear and entrance of dirt into the cylinder. The cylinder cups should be replaced, thus avoiding future problems.

6. Inspect all other brake parts and replace any that are worn or damaged.

7. Inspect the brake drum and, if necessary, refinish. Refer to Part 12-02 for refinishing.

### BRAKE BOOSTER

Check the booster operation as noted in Part 12-01. Power Brake Functional Test. If the brake booster is damaged or inoperative replace it with a new booster. **The brake booster is serviced only as an assembly.**

### HYDRAULIC LINES

Steel tubing is used throughout the brake system with the exception of the flexible hoses at the front wheels and at the rear axle housing brake tube connection.

**Always bleed the applicable primary or secondary brake system after primary or secondary brake system hose or line replacement.** Centralize the pressure differential valve after bleeding the system.

### BRAKE TUBING

If a section of the brake tubing becomes damaged, the entire section should be replaced with tubing of the same type, size, shape and length. **Copper tubing should not be used in a hydraulic system.** When bending brake tubing to fit underbody or rear axle contours, be careful not to kink or crack the tube.

All brake tubing should be double flared properly to provide good leak-proof connections. Clean the brake tubing by flushing with clean brake fluid before installation.

When connecting a tube to a hose, tube connector, or brake cylinder, tighten the tube fitting nut to specified torque with Milbar Tool 1112-144 or equivalent.

### BRAKE HOSE

A flexible brake hose should be replaced if it shows signs of softening, cracking, or other damage.

When installing a new front brake hose, position the hose to avoid contact with other chassis parts. Place a new copper gasket over the hose fitting and thread the hose assembly into the front wheel cylinder. Engage the opposite end of the hose to the bracket on the frame. Install the horseshoe-type retaining clip, and connect the tube to the hose with the tube fitting nut.

A rear brake hose should be installed so that it does not touch the muffler outlet pipe or shock absorber. Thread the hose into the rear brake tube connector. Engage the front end of the hose to the bracket on the frame. Install the horseshoe-type retaining clip, and connect the tube to the hose with the tube fitting nut.

**100% SATISFACTION GUARANTEED**

**BUY IT NOW!**

**Click Here To Order**

PayPal American Express Cards Discover MasterCard VISA

### 3 SPECIAL TOOLS

#### SPECIAL TOOLS

Ford Tool No.	Description
Rotunda WRE-500-50	Brake Pedal Effort Gauge
Rotunda ARE-345	Vacuum and Fuel Pump Tester Gauge
Rotunda 1436	Diaphragm Type Bleeder
Tool 4201-C	Universal Dial Indicator and Bracket
Rotunda FRE-70160	Ball and Bar Gauge
Rotunda-FRE-1432	Brake Drum Micrometer
Rotunda-2249-2	Disc Brake Attachment
Milbar 1112-144	Inch Pound Torque Wrench

CH1717-A



**BUY IT NOW!**  
Click Here To Order 







# PART 12-02 Drum Brake

COMPONENT INDEX Applies Only To Models Indicated	All Models	Ford	Mercury	Meteor	Cougar	Fairlane	Falcon	Maverick	Montego	Mustang	Lincoln-Continental	Thunderbird	Continental-Mark III
<b>BRAKE BACKING PLATE</b>	02-07												
Removal and Installation	02-07												
<b>BRAKE BOOSTER</b>	02-02												
Cleaning and Inspection - See Part 12-01 Description	02-02												
Removal and Installation	02-10												
<b>BRAKE DRUM</b>	02-05												
Cleaning and Inspection - See Part 12-01 Refinishing	02-13												
Removal and Installation (Front)	02-05												
Removal and Installation (Rear)	02-05												
<b>BRAKE PEDAL</b>		02-11	02-11	02-11	02-11	02-11	02-11	02-11	02-11	02-11	N/A	N/A	N/A
Removal and Installation		02-11	02-11	02-11	02-11	02-11	02-11	02-11	02-11	02-11	N/A	N/A	N/A
<b>BRAKE SHOES</b>	02-03												
Adjustments	02-03												
Relining	02-13												
Removal and Installation	02-05												
<b>DRUM BRAKE</b>	02-02												
Description	02-02												
<b>DUAL BRAKE SYSTEM</b>	02-02												
Description	02-02												
<b>MASTER CYLINDER</b>	02-02												
Cleaning and Inspection		02-14	02-14	02-14	02-14	02-14	02-14	02-14	02-14	02-14	N/A	N/A	N/A
Disassembly and Overhaul		02-13	02-13	02-13	02-13	02-13	02-13	02-13	02-13	02-13	N/A	N/A	N/A
Removal and Installation - Non-Power		02-07	02-07	02-07	02-08	02-08	02-08	02-08	02-08	02-08	N/A	N/A	N/A
Removal and Installation - Power		02-09	02-09	02-09	02-09	02-09	02-09	N/A	02-09	02-09	N/A	N/A	N/A
<b>PRESSURE DIFFERENTIAL VALVE</b>	02-02												
Removal and Installation	02-09												
<b>WHEEL CYLINDER</b>	02-04												
Cleaning and Inspection	02-04												
Disassembly and Overhaul	02-04												
Removal and Installation	02-06												

A page number indicates that the item is for the vehicle(s) listed at the head of the column.  
 N/A indicates that the item is not applicable to the vehicle(s) listed.

**100% GUARANTEED**

**BUY IT NOW!**

**Click Here To Order**

PayPal American Express Discover MasterCard VISA

# 1 DESCRIPTION

The drum brake system employs single anchor, internal expanding and self adjusting brake assemblies.

The self-adjusting brake mechanism consists of a cable, cable guide, adjusting lever, adjusting screw assembly, and adjuster spring (Fig. 1). The cable is hooked over the anchor pin at the top and is connected to the lever at the bottom. The cable is routed along the web of the secondary brake shoe by means of the cable guide. The adjuster spring is hooked to the primary brake shoe and to the lever. The automatic adjuster operates only when the brakes are applied while the vehicle is moving rearward and only when the secondary shoe is free to move toward the drum beyond a predetermined point.

A vacuum booster is used with the power drum brake system.

## DUAL MASTER CYLINDER BRAKE SYSTEM

The dual-master cylinder brake

system has been incorporated in all models to provide increased safety. The system consists of a dual-master cylinder (Fig. 2), pressure differential valve assembly and a switch (Fig. 3). The switch on the differential valve activates a dual-brake warning light, located on the instrument panel.

## BRAKE BOOSTER SYSTEM

This diaphragm-type brake booster is a self-contained vacuum-hydraulic braking unit mounted on the engine side of the dash panel.

The brake booster is of the vacuum suspended-type which utilizes engine intake manifold vacuum and atmospheric pressure for its power.

Adjustment of the push rod and replacement of the check valve and grommet are the only services permitted on the brake booster. The booster unit is to be exchanged when it is inspected, checked and found to be inoperative.

## PRESSURE DIFFERENTIAL VALVE

A self centering pressure differential valve assembly is used on all vehicles having power or non-power drum type brakes.

The valve body is step bored to accommodate a sleeve and seal installed over the piston and into the larger valve body bore in the front brake system area. The brake warning light switch is mounted at the center of the valve body and the spring loaded switch plunger fits into a tapered shoulder groove in the center of the piston. In this position the electrical continuity through the switch is interrupted and the brake warning lamp on the instrument panel is out. (Fig. 3)

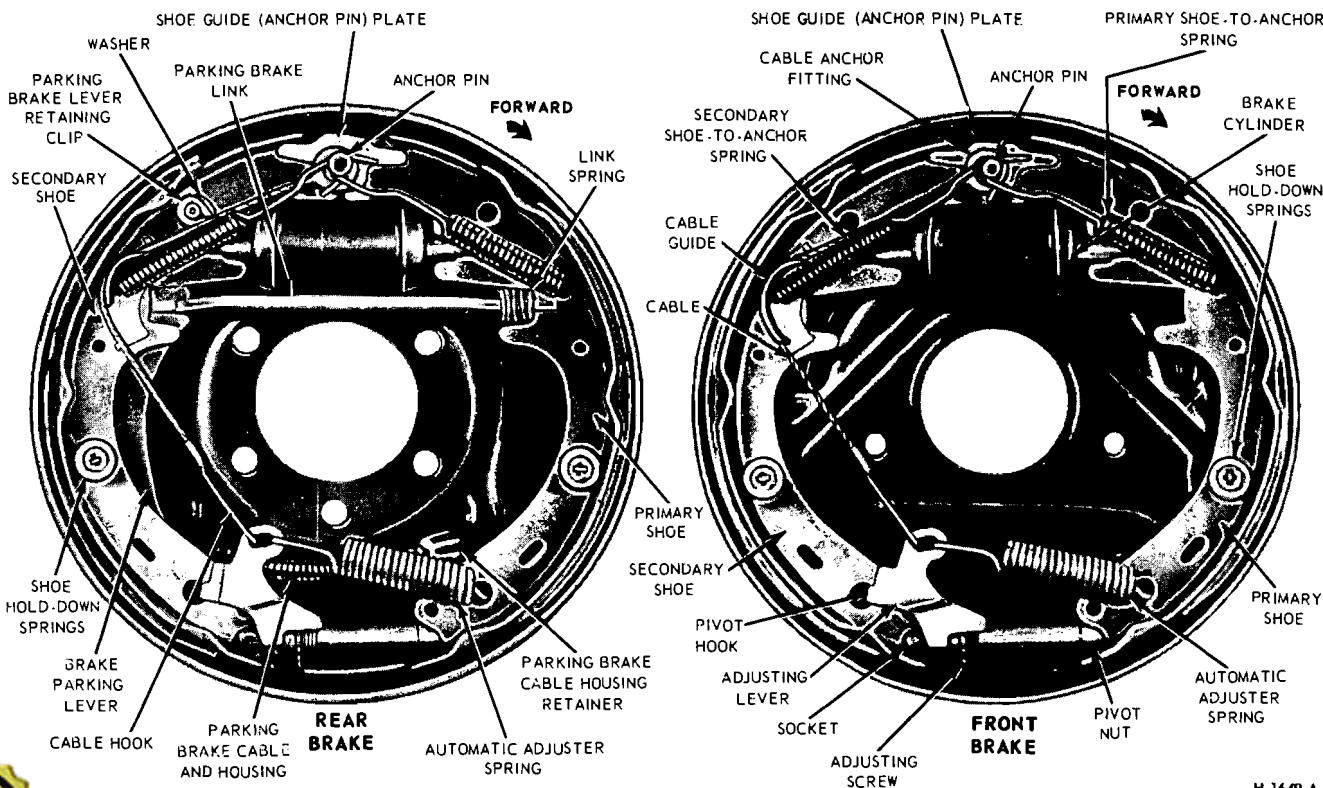

H 1649-A

**100% SATISFACTION GUARANTEED**

**BUY IT NOW!** assemblies

**Click Here To Order**

PayPal, American Express, Discover, MasterCard, VISA

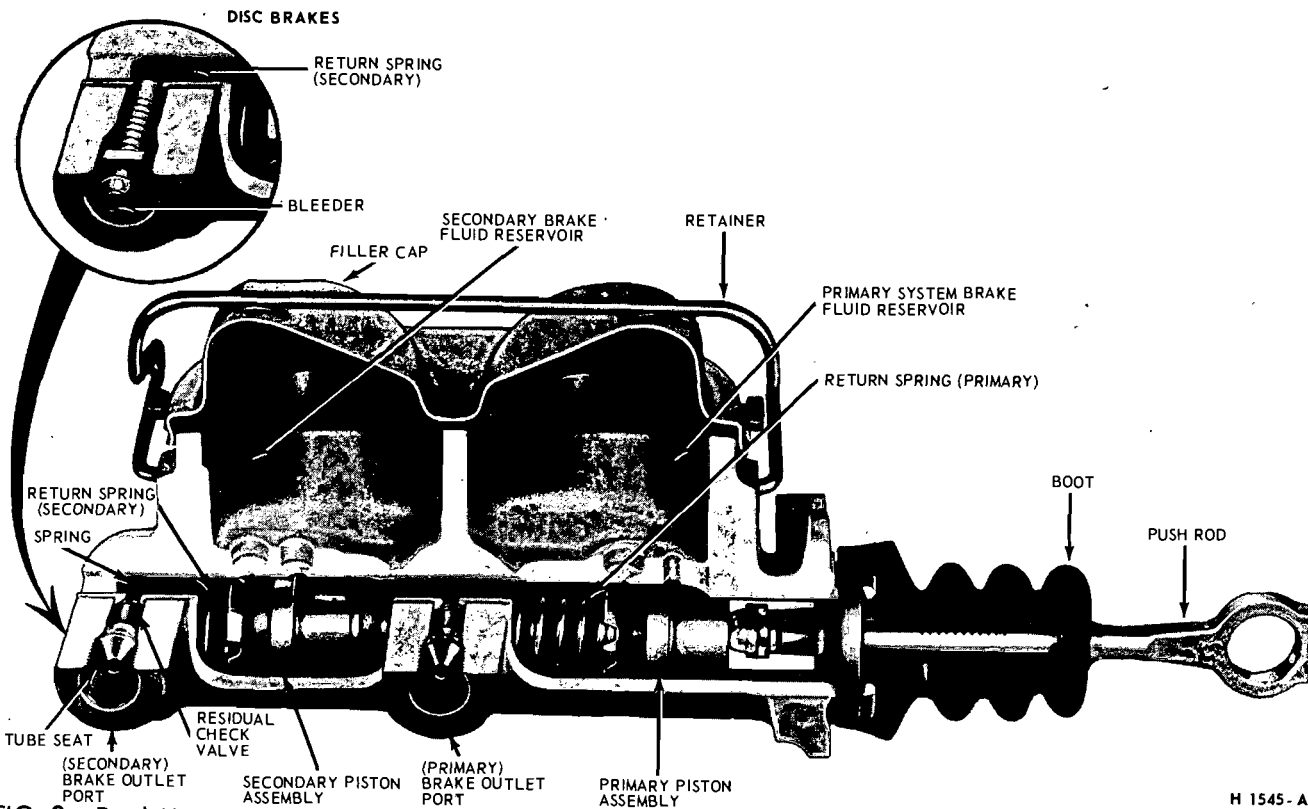

FIG. 2—Dual Master Cylinder—Typical

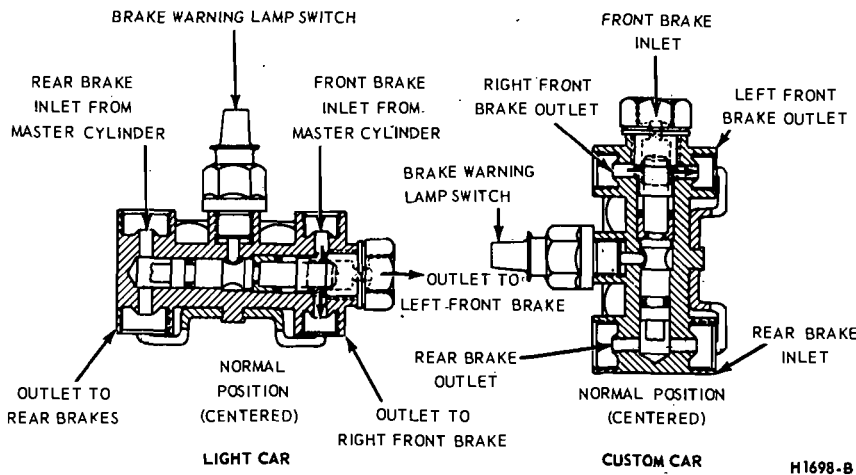

FIG. 3—Pressure Differential Valve and Brake Warning Light Switch

## 2 IN-VEHICLE ADJUSTMENTS AND REPAIRS

After any brake service work, push down on a firm brake pedal before driving the vehicle. Riding the brake

### BRAKE SHOE ADJUSTMENTS

The hydraulic drum brakes are self-adjusting and require a manual adjustment only after the brake shoes

have been relined, replaced, or when the length of the adjusting screw has been changed while performing some other service operation. The manual adjustment is performed with the drums removed, using the tool and

**100% SATISFACTORY GUARANTEED**

**BUY IT NOW!**

**Click Here To Order**

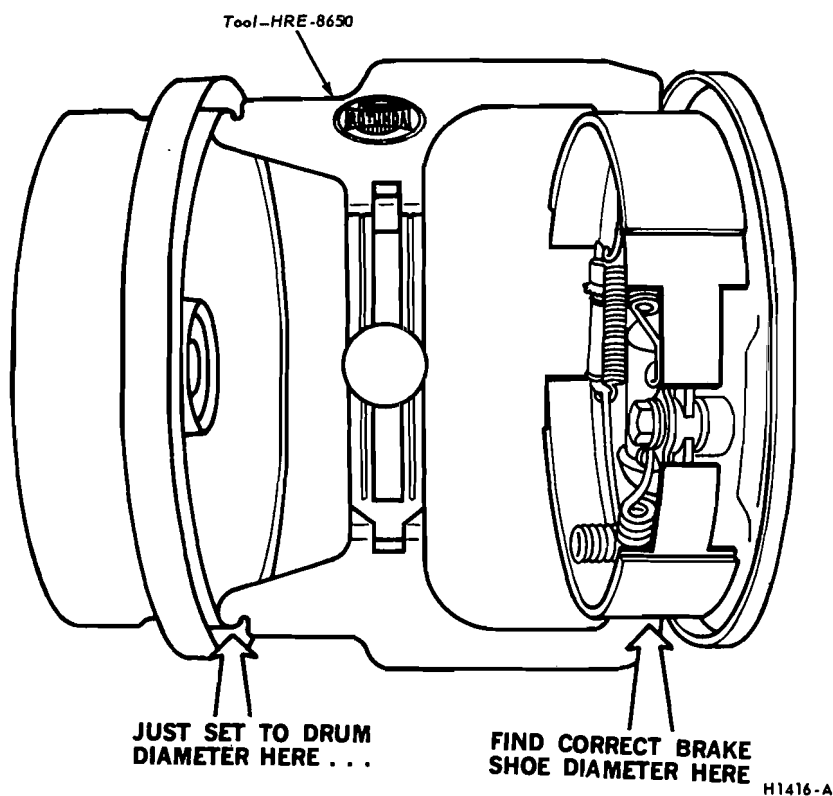

FIG. 4—Adjusting Brake Shoes Using Tool HRE-8650

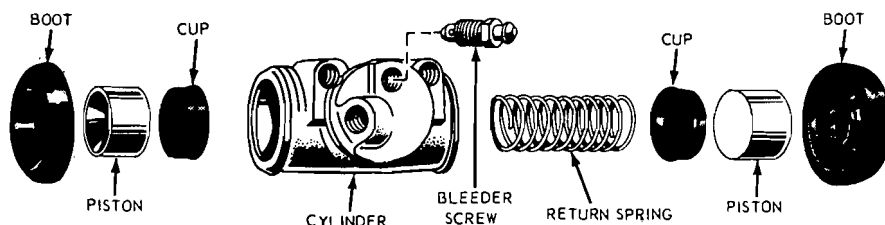

FIG. 5—Brake Wheel Cylinder—Typical

the procedure detailed below.

When adjusting the rear brake shoes, check the parking brake cables for proper adjustment. Make sure that the equalizer operates freely.

To adjust the brake shoes:

1. Use Rotunda Tool HRE 8650, (Fig. 4) to determine the inside diameter of the drum braking surface.

2. Reverse the tool as shown in Fig. 4 and adjust the brake shoe diameter to fit the gauge. Hold the automatic adjusting lever out of engagement while rotating the adjusting

slots. Make sure the adjusting screw rotates freely. If necessary, lubricate the adjusting screw threads with a thin, uniform coating of CIAZ 19590-B Moly Dysulfide.

3. Rotate Tool HRE 8650 around the brake shoes to be sure of the setting.

4. Apply a small quantity of high temperature grease to the points where the shoes contact the backing plate, being careful not to get the lubricant on the linings.

5. Install the drums. Install Tinnerman nuts and tighten securely.

6. Install the wheels on the drums and tighten the nuts to specification.

7. Complete the adjustment by applying the brakes several times with a minimum of 50 lbs pressure on the pedal while backing the vehicle. After each stop the vehicle must be moved forward.

8. After the brake shoes have been properly adjusted, check the operation of the brakes by making several stops while operating in a forward direction.

## WHEEL CYLINDER REPAIR

Wheel cylinders should not be disassembled unless they are leaking or unless new cups and boots are to be installed. It is not necessary to remove the brake cylinder from the backing plate to disassemble, inspect, or hone and overhaul the cylinder. Removal is necessary only when the cylinder is damaged or scored beyond repair.

## DISASSEMBLY

1. Remove the links and the rubber boots from the ends of the brake cylinder. Remove the pistons, cups, and return spring from the cylinder bore (Fig. 5).

2. Remove the bleeder screw from the cylinder.

## INSPECTION

1. Wash all parts in clean brake fluid. Dry with compressed air.

2. Replace scored pistons. Always replace the rubber cups and dust boots.

3. Inspect the cylinder bore for score marks or rust. If either condition is present the cylinder bore must be honed. However, the cylinder should not be honed more than 0.003 inch beyond its original diameter.

4. Check the bleeder hole to be sure that it is open.

## ASSEMBLY

1. Apply a light coating of heavy-duty brake fluid to all internal parts.

2. Thread the bleeder screw into the cylinder and tighten securely.

3. Insert the return spring, cups, and pistons into their respective positions in the cylinder bore (Fig. 12). Place a boot over each end of the cylinder. Bleed the brake system.

100% SATISFACTION GUARANTEED

**BUY IT NOW!**

Click Here To Order

PayPal American Express Cards Discover/Novus MasterCard VISA

### 3 REMOVAL AND INSTALLATION

#### FRONT BRAKE DRUM

##### REMOVAL

1. Raise the vehicle until the wheel and tire clear the floor. Remove the wheel cover or hub cap, and remove the wheel and tire from the drum.

2. Remove the grease cap from the hub. Remove the cotter pin, nut lock, adjusting nut, and flat washer from the spindle. Remove the outer bearing cone and roller assembly.

3. Pull the drum off the wheel spindle.

4. If the drum will not come off, pry the rubber cover from the brake backing plate. Insert a narrow screwdriver through the slot and disengage the adjusting lever from the adjusting screw. While holding the adjusting lever away from the adjusting screw, back off the adjusting screw with the brake adjusting tool (Fig. 6). **Be very careful not to burr, chip, or damage the notches in the adjusting screw; otherwise, the self-adjusting mechanism will not function properly.**

H1590-A 2 1/16 x 2 1/2

##### INSTALLATION

1. If the drum is being replaced, remove the protective coating from the new drum with carburetor degreaser. Then, use sandpaper to insure that no residue remains. Wipe the drum with a cloth soaked with denatured alcohol. Install new bearings and grease seal. Pack the wheel bearings, install the inner bearing cone and roller assembly in the inner cup, and install the new grease seal see Part 11-02.

If the original drum is being installed, make sure that the grease in the hub is clean and adequate.

2. Adjust the brakes and install the drum assembly as outlined under Brake Shoe Adjustments in this section.

3. Install the outer wheel bearing, washer and adjusting nut.

4. Adjust the wheel bearing as outlined in Part 11-02, then install the grease cap. Install the wheel and hub cap.

is clear of the floor.

2. Remove the hub cap and wheel. Remove the three Tinnerman nuts and remove the brake drum. If the drum will not come off, pry the rubber cover from the backing plate. Insert a narrow screwdriver through the hole in the backing plate, and disengage the adjusting lever from the adjusting screw. While holding the adjusting lever away from the adjusting screw, back off the adjusting screw with the brake adjusting tool (Fig. 6). **Be very careful not to burr, chip, or damage the notches in the adjusting screw; otherwise, the self-adjusting mechanism will not function properly.**

##### INSTALLATION

1. Remove the protective coating from a new drum with carburetor degreaser; then sand lightly and wipe with a cloth soaked with denatured alcohol.

2. Adjust the brakes as outlined under Brake Shoe Adjustments in this section. Place the drum over the brake assembly and into position.

3. Install the three Tinnerman nuts and tighten securely. Install the wheel on the axle shaft flange studs against the drum, and tighten the attaching nuts to specifications.

#### BRAKE SHOES AND ADJUSTING SCREW

##### REMOVAL

1. With the wheel and drum removed install a clamp over the ends of the brake cylinder as shown in Fig. 7.

2. Remove the secondary shoe to anchor spring with the tool shown in Fig. 7. With the same tool remove the primary shoe to anchor spring and unhook the cable eye from the anchor pin.

3. On Ford, Mercury, Meteor, Thunderbird, Continental Mark III and Lincoln Continental models, remove the shoe guide (anchor pin) plate (Fig. 1).

4. Remove the shoe hold-down springs, shoes, adjusting screw, pivot nut, socket and automatic adjustment parts.

5. On rear brakes, remove the parking brake link and spring. Disconnect the parking brake cable from the parking brake lever.

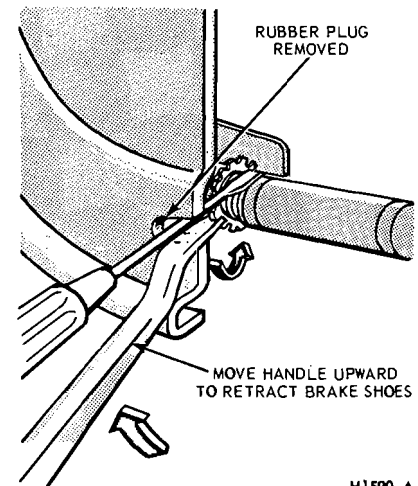

H1590-A

FIG. 6—Backing Off Brake Adjustment

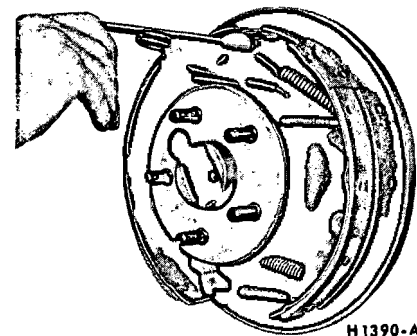

H1390-A

FIG. 7—Retracting Spring Removal

6. After removing the rear brake secondary shoe, disassemble the parking brake lever from the shoe by removing the retaining clip and spring washer (Fig. 1).

##### INSTALLATION

1. Before installing the rear brake shoes, assemble the parking brake lever to the secondary shoe and secure with the spring washer and retaining clip.

2. Apply a light coating of high-temperature grease at the points where the brake shoes contact the backing plate.

3. Position the brake shoes on the backing plate and secure the assembly with the hold down springs. On the rear brake, install the parking brake link and spring, back off the parking brake adjustment then connect the

**100% SATISFACTION GUARANTEED**

**BUY IT NOW!**

**Click Here To Order**

PayPal   American Express   Discover   MasterCard   VISA

parking brake cable to the parking brake lever (Fig. 1).

4. Install the shoe guide (anchor pin) plate on the anchor pin when so equipped.

5. Place the cable eye over the anchor pin with the crimped side toward the backing plate.

6. Install the primary shoe to anchor spring (Fig. 8).

7. Install the cable guide on the secondary shoe web with the flanged hole fitted into the hole in the secondary shoe web. Thread the cable around the cable guide groove (Fig. 1).

It is imperative that the cable be positioned in this groove and not between the guide and the shoe web.

8. Install the secondary shoe to anchor spring with the tool shown in Fig. 8.

Be certain that the cable eye is not cocked or binding on the anchor pin when installed. All parts should be flat on the anchor pin. Remove the brake cylinder clamp.

9. Apply high-temperature grease CIAZ 19590-B Moly Dysulfide to the threads and the socket end of the adjusting screw. Turn the adjusting screw into the adjusting pivot nut to the limit of the threads and then back

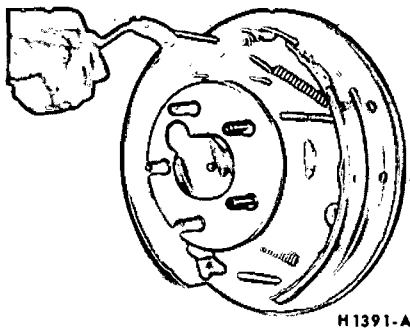

H1391-A

FIG. 8—Retracting Spring Installation

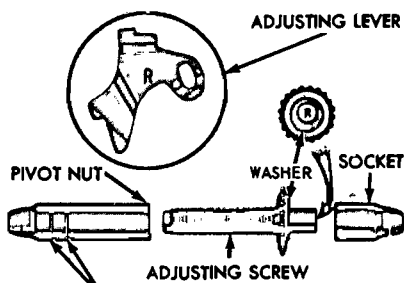

IDENTIFICATION LINES

H1143-C

off 1/2 turn.

Interchanging the brake shoe adjusting screw assemblies from one side of the vehicle to the other would cause the brake shoes to retract rather than expand each time the automatic adjusting mechanism operated. To prevent installation on the wrong side of the vehicle, the socket end of the adjusting screw is stamped with an R or L (Fig. 9). The adjusting pivot nuts can be distinguished by the number of grooves machined around the body of the nut. Two grooves on the nut indicate a right thread; one groove indicates a left thread.

10. Place the adjusting socket on the screw and install this assembly between the shoe ends with the adjusting screw toothed wheel nearest the secondary shoe.

11. Hook the cable hook into the hole in the adjusting lever. The adjusting levers are stamped with an R or L to indicate their installation on right or left brake assembly (Fig. 9).

12. Position the hooked end of the adjuster spring completely into the large hole in the primary shoe web. The last coil of the spring should be at the edge of the hole. Connect the loop end of the spring to the adjuster lever hole.

13. Pull the adjuster lever, cable and automatic adjuster spring down and toward the rear to engage the pivot hook in the large hole in the secondary shoe web (Fig. 1).

14. After installation, check the action of the adjuster by pulling the section of the cable between the cable guide and the anchor pin toward the secondary shoe web far enough to lift the lever past a tooth on the adjusting screw wheel. The lever should snap into position behind the next tooth, and release of the cable should cause the adjuster spring to return the lever to its original position. This return action of the lever will turn the adjusting screw one tooth.

If pulling the cable does not produce the action described, or if the lever action is sluggish instead of positive and sharp, check the position of the lever on the adjusting screw toothed wheel. With the brake in a vertical position (anchor at the top), the lever should contact the adjusting wheel 3/16 inch (plus or minus 1/32 inch) above the centerline of the screw. If the contact point is below this centerline, the lever will not lock on the teeth in the adjusting screw wheel, and the screw will not be turned as the lever is actuated by the cable.

To determine the cause of this condition:

a. Check the cable end fittings. The cable should completely fill or extend slightly beyond the crimped section of the fittings. If it does not meet this specification, possible damage is indicated and the cable assembly should be replaced.

b. Check the cable length. On Ford, Mercury, Meteor, Thunderbird; Continental Mark III, and Lincoln Continental models, the cable should measure 11 1/8 inches (plus or minus 1/64 inch) from the end of the cable anchor to the end of the cable hook. On Fairlane, Montego, Falcon; Mustang, and Cougar models the cable should measure 8.13/32 inches on 9 inch brakes or 9 3/4 inches on 10 inch brakes from the end of the cable anchor to the end of the cable hook.

c. Check the cable guide for damage. The cable groove should be parallel to the shoe web, and the body of the guide should lie flat against the web. Replace the guide if it shows damage.

d. Check the pivot hook on the lever. The hook surfaces should be square with the body of the lever for proper pivoting. Replace the lever if the hook shows damage.

e. See that the adjusting screw socket is properly seated in the notch in the shoe web.

## WHEEL CYLINDER

### REMOVAL

1. Remove the wheel and the drum.

2. Remove the brake shoe assemblies, following procedures outlined in this section.

3. Disconnect the brake line from the brake cylinder. On a vehicle with a vacuum brake booster, be sure the engine is stopped and there is no vacuum in the booster system before disconnecting the hydraulic lines.

To disconnect the hose at a front cylinder, loosen the tube fitting that connects the opposite end of the hose to the brake tube at a bracket on the frame. Remove the horseshoe-type retaining clip from the hose and bracket, disengage the hose from the bracket, then unscrew the entire hose assembly from the front wheel cylinder.

At a rear cylinder, unscrew the tube fitting that connects the tube to the cylinder. Do not pull the metal tube away from the cylinder. Pulling

**100% SATISFACTION GUARANTEED**

**BUY IT NOW!**

**Click Here To Order**

PayPal | American Express | Discover | MasterCard | VISA

the tube out of the cylinder connection will bend the metal tube and make installation difficult. The tube will separate from the cylinder when the cylinder is removed from the backing plate.

4. On all except the front wheels on Ford, Mercury, and Meteor models, remove the wheel cylinder attaching bolts and lock washers and remove the cylinder. On the front wheel of Ford, Mercury and Meteor models, remove the nut and washer that attaches the cylinder to the anchor pin. Remove the cylinder from the anchor pin.

### INSTALLATION

Wipe the end(s) of the hydraulic line to remove any foreign matter before making connections.

1. On all models except Ford, Mercury and Meteor, to install a front wheel cylinder, position the cylinder to the backing plate. Install the two lock washers and attaching bolts. Torque them to specifications.

On Ford, Mercury and Meteor models, to install a front wheel cylinder, position the cylinder on the anchor pin against the backing plate. Install the washer and cylinder attaching nut on the anchor pin, and torque it to specification. Lock the washer retainer securely.

2. Install a new copper gasket over the hose fitting. Thread the hose into the cylinder and tighten it to specified torque.

3. Engage the opposite end of the hose to the bracket on the frame. Install the horseshoe-type retaining clip, and connect the brake tube to the hose with the tube fitting nut. Tighten the nut to specification with tool 1112-144.

4. To install a rear wheel cylinder, place the rear wheel cylinder into position. Enter the tubing into the cylinder, and start the tube fitting nut into the threads of the cylinder.

5. Secure the cylinder to the backing plate by installing the attaching bolts and lock washers.

6. Tighten the tube fitting nut to specification with tool 1112-144.

7. Install the links in the ends of the wheel cylinder, install the shoes and adjuster assemblies, and adjust the shoes as outlined in this section.

Adjust the brakes as described part. Install the brake drum

## BRAKE BACKING PLATE

### REMOVAL

1. Remove the wheel and brake drum. Disconnect the brake line from the brake cylinder.

2. Remove the brake shoe and adjuster assemblies and the wheel cylinder as outlined in this section. On the rear wheels, disconnect the parking brake lever from the cable.

3. If the rear backing plate is being replaced, remove the axle shaft from the applicable rear axle as outlined in Group 15, Part 2 or 3, Rear Axle, Section 2, disengage parking brake cable retainer from backing plate. Remove the backing plate and gasket.

If the front backing plate is being replaced, remove the bolts and nuts that secure the backing plate to the front wheel spindle and remove the plate and gasket.

### INSTALLATION

If a rear backing plate is to be replaced, position a new rear backing plate and gasket on the attaching bolts in the axle housing flange. Insert parking brake cable into backing plate and secure retaining fingers. Install the rear axle shaft for applicable rear axle. Refer to Group 15 Part 2 or 3 Rear Axle, Section 2 for the proper installation procedure.

1. If the front brake backing plate

is to be replaced, position a new front backing plate and gasket to the wheel spindle and install the attaching bolts and nuts.

2. Install the wheel cylinder and connect the brake line as outlined in this section.

3. Install the brake shoe and adjuster assemblies as outlined in this section. On a rear brake, connect the parking brake cable to the lever.

4. Adjust the brake shoes as outlined in this section, and install the brake drums and wheels. Bleed the brake system and centralize the differential valve as outlined in Part 12-01.

## DUAL MASTER CYLINDER—NON POWER BRAKES

### FORD, MERCURY AND METEOR

#### Removal

Refer to Fig. 10.

1. Disconnect the stoplight switch wires at the connector. Remove the spring retainer. Slide the stop light switch off the brake pedal pin just far enough to clear the end of the pin, then lift the switch straight upward from the pin. Use care to avoid switch damage during removal.

2. Slide the master cylinder push rod and the nylon washers and bushings off the brake pedal pin.

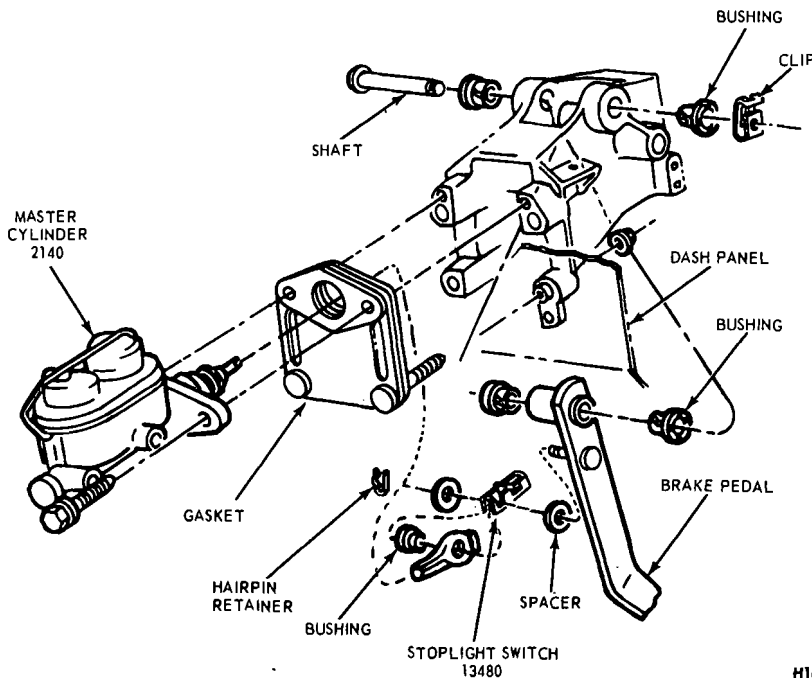

FIG. 10—Dual Master Cylinder Installation—Non Power Brakes—Ford, Mercury, and Meteor

H1637-A

**100% SATISFACTION GUARANTEED**

**BUY IT NOW!**

**Click Here To Order**

PayPal | American Express | Discover | MasterCard | VISA

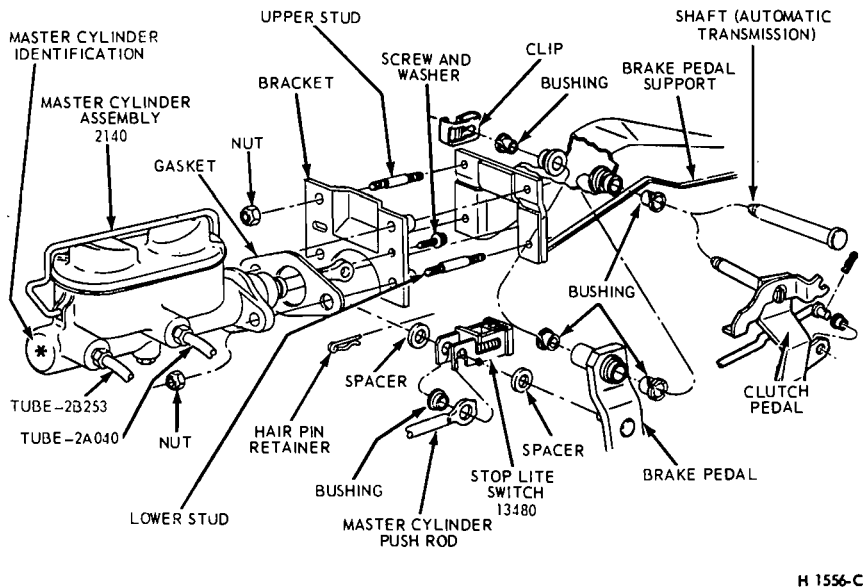

FIG. 11—Dual Master Cylinder Installation—Non Power Brake—Fairlane, Montego, and Falcon

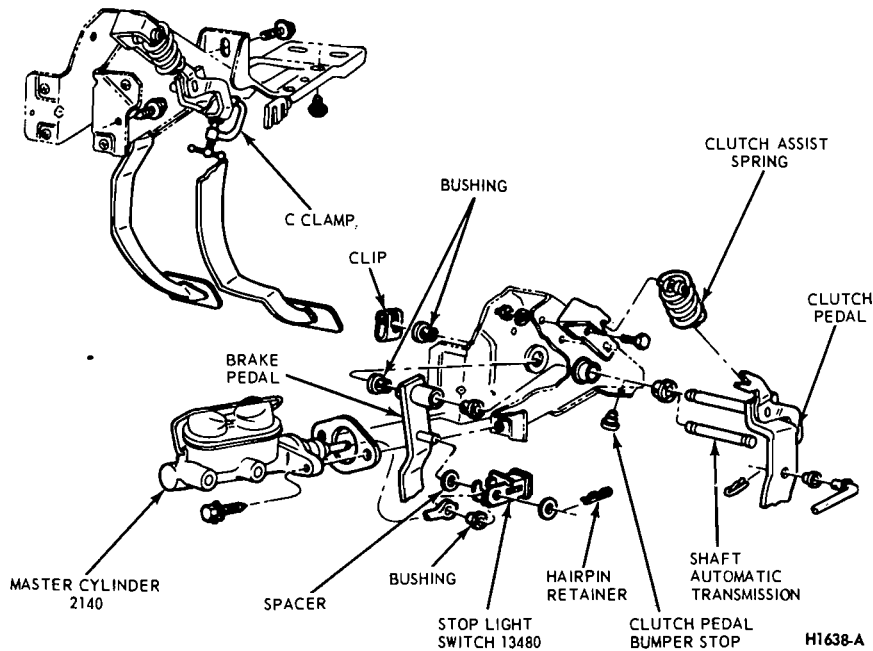

FIG. 12—Dual Master Cylinder Installation—Non Power Brake—Mustang and Cougar

**Installation**

1. Position the boot on the push rod and secure the boot to the master cylinder. Carefully insert the master cylinder push rod and boot through the dash panel opening and position the master cylinder on the panel.
2. Install the cap screws at the dash panel and torque them to specification.
3. Coat the nylon bushings with SAE 10W oil. Install the nylon washer and bushing on the brake pedal pin.
4. Position the stop light switch on the brake pedal pin, install the nylon bushing and washer and secure them in position with the spring retainer.
5. Connect the wires at the stop light switch connector.
6. Connect the brake lines to the master cylinder leaving the brake line fittings loose.
7. Fill the master cylinder with the specified brake fluid to within 1/4 inch of the top of the dual reservoirs. Use Ford Brake Fluid—Extra Heavy Duty—Part Number C6AZ-19542-A (ESA-M6C25-A) or equivalent for all drum brake applications. The extra heavy duty brake system fluid is colored blue for identification. Do not mix low temperature brake fluids with the specified fluid for the power disc brake system.
8. Bleed the dual-master cylinder and the primary and secondary brake systems. Centralize the pressure differential valve. Refer to Hydraulic System Bleeding and Centralizing of the Differential Valve, Part 12-01, for proper procedure.
9. Operate the brakes several times, then check for external hydraulic leaks.

**FAIRLANE, MONTEGO, MAVERICK, FALCON, MUSTANG AND COUGAR**

**Removal**

- Refer to Figs. 11 and 12.
1. Working from inside the vehicle below the instrument panel, disconnect the master cylinder push rod from the brake pedal assembly. The push rod cannot be removed from the master cylinder.
2. Disconnect the stoplight switch wires at the connector. Remove the hairpin retainer. Slide the stop light switch off the brake pedal pin just far enough to clear the end of the pin, then lift the switch straight upward.

lockwashers that secure the master cylinder to the dash panel and lift the cylinder forward and upward from the vehicle.

**100% SATISFACTION GUARANTEED**

**BUY IT NOW!**

**Click Here To Order**

PayPal, Discover, MasterCard, VISA

from the pin. Use care to avoid switch damage during removal.

3. Slide the master cylinder push rod and the nylon washers and bushings off the brake pedal pin.

4. Remove the brake tubes from the primary and secondary outlet ports of the master cylinder.

5. Remove the lock nuts or cap screw and lockwashers that secure the master cylinder to the dash panel and lift the cylinder forward and upward from the car.

### Installation

Refer to Figs. 11 and 12.

1. Position the boot on the push rod and secure the boot to the master cylinder. Carefully insert the master cylinder push rod and boot through the dash panel opening.

2. On Fairlane, Falcon or Montego models, position the gasket and master cylinder on the mounting studs on the dash panel. Install the lock nuts on the studs at the dash panel and torque them to specification.

3. On Mustang or Cougar models, position the gasket and master cylinder on the dash panel. Install the retaining screws and torque them to specification. Coat the nylon bushings with SAE 10W oil. Install the nylon washer and bushing on the brake pedal pin.

4. Position the stop light switch on the brake pedal pin, install the nylon bushing and washer and secure them in position with the spring retainer.

5. Connect the wires at the stop light switch connector.

6. Connect the brake lines to the master cylinder and tighten to specified torque.

7. Fill the master cylinder with the specified brake fluid to within 1/4 inch of the top of the dual reservoirs. Use Ford Brake Fluid—Extra Heavy Duty—Part Number C6AZ-19542-A for all brake applications. The brake fluid is colored blue for identification. Do not mix low temperature brake fluids with the specified fluid for the brake system.

8. Bleed the dual-master cylinder and the primary and secondary brake systems. Centralize the pressure differential valve. Refer to Hydraulic System Bleeding and Centralizing of the Differential Valve, Part 2-1, Section 2 for the proper procedure.

## DUAL MASTER CYLINDER— POWER BRAKES

### REMOVAL

1. Remove the brake tubes from the primary and secondary outlet ports of the master cylinder (Figs. 13 thru 15).

2. Remove the two nuts and two lock washers attaching the master cylinder to the brake booster assembly.

3. Slide the master cylinder forward and upward from the vehicle.

### INSTALLATION

1. Before installing the master cylinder, check the distance from the outer end of the booster assembly push rod to the master cylinder mounting surface. Turn the push rod adjusting screw in or out as required to obtain the specified length. Refer to Part 12-01, Power Brake Master Cylinder Push Rod Adjustment for the proper procedure.

2. Position the master cylinder assembly over the booster push rod and onto the two studs on the booster assembly (Figs. 13 thru 15).

3. Install the attaching nuts and

lock washers and torque them to specifications.

4. Install the front and rear brake tubes to the master cylinder outlet fittings.

5. Fill the master cylinder with the specified brake fluid to within 1/4 inch of the top of the dual reservoirs. Use Ford Brake Fluid—Extra Heavy Duty—Part Number C6AZ-19542-A (ESA-M6C25-A) for all brake applications. The extra heavy duty brake fluid is colored blue for identification. Do not mix low temperature brake fluids with the specified fluids for the disc brake system.

6. Bleed the dual-master cylinder and the primary and secondary brake systems. Centralize the pressure differential valve. Refer to Hydraulic System Bleeding and Centralizing of the Differential Valve, Part 12-01, for the proper procedure.

7. Operate the brakes several times, then check for external hydraulic leaks.

## PRESSURE DIFFERENTIAL VALVE ASSEMBLY

### REMOVAL

The pressure differential valve

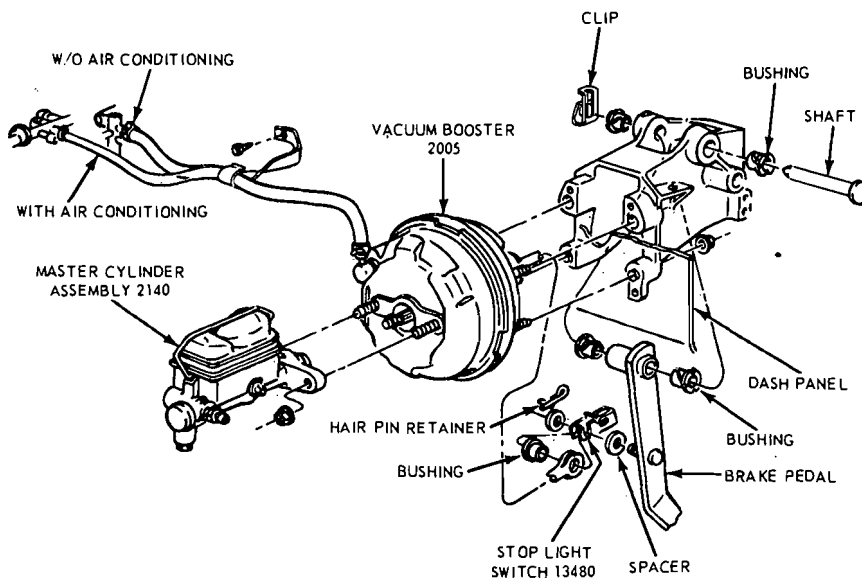

FIG. 13—Master Cylinder Installation—Power Brake—Ford, Mercury and Meteor

H 1642-A

**100% GUARANTEED**

**BUY IT NOW!**

**Click Here To Order**

PayPal, American Express, Discover, MasterCard, VISA

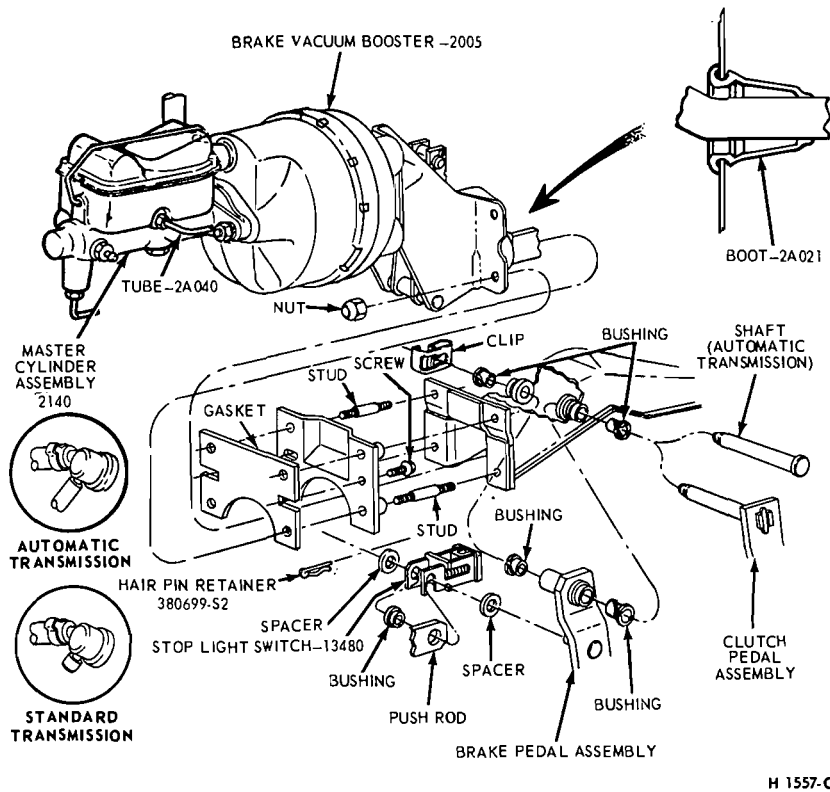

FIG. 14—Master Cylinder Installation—Power Brake—Fairlane, Montego and Falcon

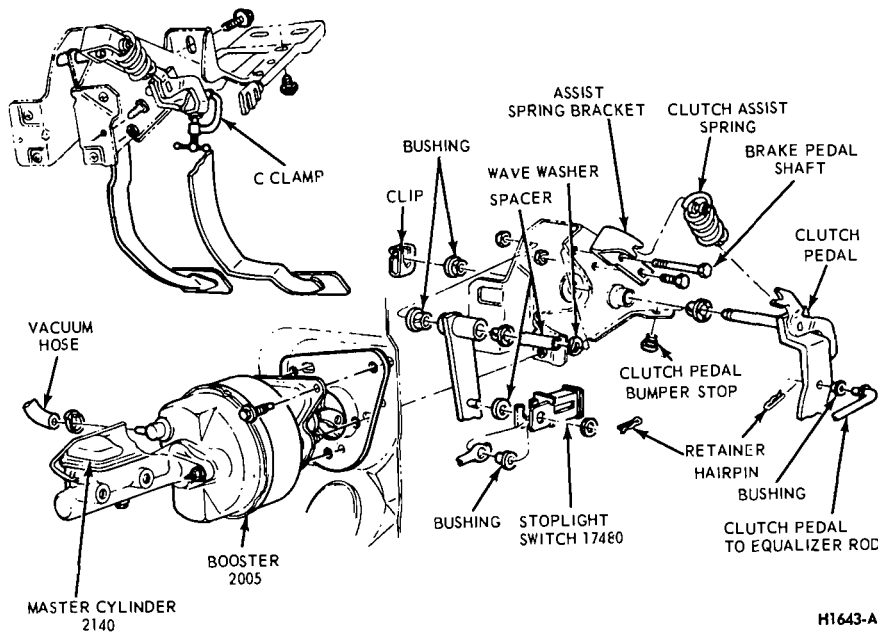

FIG. 15—Master Cylinder Installation—Power Brake—Mustang and Cougar

sembly (Fig. 3).

3. Remove the two attaching nuts and bolts from the valve bracket on the underside of the fender apron and remove the valve assembly and bracket from the vehicle.

**INSTALLATION**

1. Position the valve assembly and bracket to the fender apron. Install the attaching nuts and bolts: torque them to specifications.

2. Install the front inlet and rear outlet tubes to the valve assembly. Torque them to specifications.

3. Connect the brake warning light connector to the warning light switch.

4. Bleed the system and centralize the pressure differential valve following the procedures in Centralizing the Pressure Differential Valve.

**BRAKE BOOSTER**

**REMOVAL**

1. Working from inside the vehicle below the instrument panel, disconnect the booster push rod from the brake pedal assembly. To do this, proceed as follows:

Disconnect the stop light switch wires at the connector. Remove the hairpin retainer. Slide the stop light switch off from the brake pedal pin just far enough for the switch outer hole to clear the pin, and then remove the switch from the pin and booster push rod. Be careful not to damage the switch during removal. Slide the booster push rod and the nylon washers and bushing off the brake pedal pin (Figs 13 thru 15).

2. Open the hood and remove the master cylinder from the booster. Secure it to one side without disturbing the hydraulic lines. It is not necessary to disconnect the brake lines, but care should be taken that the brake lines are not deformed. Permanent deformation of brake lines can lead to tube failure.

3. Disconnect the manifold vacuum hose or hoses from the booster unit.

4. Remove the booster-to-dash panel attaching nuts or bolts (Figs. 13 thru 15). Remove the booster and bracket assembly from the dash panel, sliding the push rod link out from the engine side of the dash panel.

5. On Fairlane, Montego, and Falcon models, remove the push rod link boot from the dash panel.

light connector from the warning light switch.

2. Disconnect the front inlet and rear outlet tubes from the valve as-

100% SATISFACTION GUARANTEED

**BUY IT NOW!**

Click Here To Order

## INSTALLATION

1. On Fairlane, Montego and Falcon models, install the push rod link boot in the hole in the dash panel as shown in Fig. 14. Install the four spacers on the mounting studs.

2. Mount the booster and bracket assembly to the dash panel by inserting the push rod or push rod link in through the hole and boot in the dash panel. Install the bracket-to-dash panel attaching lock nuts or bolts (Figs. 13 thru 15).

3. Connect the manifold vacuum hose or hoses to the booster.

4. Before installing the master cylinder, check the distance from the outer end of the booster assembly push rod to master cylinder surface. Turn the screw in or out to obtain the specified length. Refer to Part 12-01, Power Brake Master Cylinder Push Rod Adjustment. Install the master cylinder and torque the attaching nuts to specifications.

5. Working from inside the vehicle below the instrument panel, connect the booster push rod link to the brake pedal assembly. To do this, proceed as follows:

Install the inner nylon washer, the booster push rod, and the bushing on the brake pedal pin. Position the switch so that it straddles the push rod with the switch slot on the pedal pin and the switch outer hole just clearing the pin. Slide the switch completely onto the pin, and install the nylon washer as shown in Figs. 13 thru 15. **Be careful not to bend or deform the switch.** Secure these parts to the pin with the hairpin retainer. Connect the stop light switch wires to the connector, and install the wires in the retaining clip.

## BRAKE PEDAL

### FORD, MERCURY AND METEOR

#### Removal

1. Disconnect the stop light switch wires at the connector.

2. Remove the hairpin retainer. Slide the stop light switch off the brake pedal pin **just far enough for the switch outer hole to clear the pin,** and then lift the switch straight upward from the pin. **Be careful not to bend the switch during removal.**

3. Remove the master cylinder or booster

3. Remove the hairpin-type retainer and washer from the brake pedal shaft, then remove the shaft, the brake pedal and the bushings from the pedal support bracket.

#### Installation

1. Apply a coating of SAE 10 Engine oil to the bushings and locate bushings in their proper places on the pedal assembly and pedal support bracket (Figs. 10 and 15).

2. Position the brake pedal assembly to the support bracket, then install the pedal shaft through the support bracket and brake pedal assembly. Install the retainer.

3. Install the inner nylon washer, the master cylinder or booster push rod, and the bushing on the brake pedal pin. Position the switch so that it straddles the push rod with the switch slot on the pedal pin and the switch outer hole just clearing the pin. Slide the switch completely onto the pin, and install the nylon washer as shown in Figs. 10 and 13. **Be careful not to bend or deform the switch.** Secure these parts to the pin with the hairpin retainer.

4. Connect the stop light switch wires to the connector, and install the wires in the retaining clip.

5. Check the Brake Pedal Free Height and Travel Measurements, Part 12-01.

### FAIRLANE, MONTEGO, MAVERICK AND FALCON-MANUAL-SHIFT TRANSMISSION

#### Removal

1. Remove the clutch pedal assist spring.

2. Disconnect the clutch pedal-to-equalizer rod at the clutch pedal by removing the retainer and bushing.

3. Disconnect the stop light switch wires at the connector.

4. Remove the switch retainer, and slide the stop light switch off the brake pedal pin **just far enough for the switch outer hole to clear the pin. Then lower the switch away from the pin.**

5. Slide the master cylinder or booster push rod and the nylon washers and bushing off from the brake pedal pin (Figs. 11 and 14).

6. Remove the self-locking pin and washer from the clutch and brake pedal shaft, then remove the clutch pedal and shaft assembly, the brake

pedal assembly, and the bushings from the pedal support bracket (Figs. 11 and 14).

#### Installation

1. Apply a coating of SAE 10 engine oil to the bushings and locate all bushings in their proper places on the clutch and brake pedal assemblies.

2. Position the brake pedal to the support bracket, then install the clutch pedal and shaft assembly through the support bracket and brake pedal assembly. Install the spring clip (Figs. 11 and 14).

3. Install the clutch pedal assist spring.

4. Connect the clutch pedal-to-equalizer rod to the clutch pedal assembly with the bushing and the spring clip retainer. Apply SAE 10 engine oil to the bushing.

5. Install the inner nylon washer, the master cylinder or booster push rod, and the bushing on the brake pedal pin. Position the switch so that it straddles the push rod with the switch slot on the pedal pin and the switch outer hole just clearing the pin. Slide the switch completely onto the pin, and install the outer nylon washer as shown in Figs. 11 and 14. Secure these parts to the pin with the self-locking pin.

6. Connect the stop light switch wires to the connector, and install the wires to the retaining clip.

7. Adjust the clutch pedal free play (Group 16-02) to specification, if required.

8. Check the Brake Pedal Free Height and Travel Measurements (Part 12-01, Section 1).

### MUSTANG AND COUGAR— MANUAL-SHIFT TRANSMISSION

#### Removal

1. Disconnect the battery ground cable from the battery.

2. Remove the steering column. Refer to Part 13-02 for procedure.

3. On non-power brakes, remove the two cap screws retaining the master cylinder to the dash panel and remove the two cap screws retaining the brake pedal support bracket to the dash panel. On power brakes remove the two cap screws retaining the booster to the dash panel.

4. Working inside the vehicle, se-

cure the clutch pedal against the bumper stop with a small C-clamp as shown in Figs. 12 and 15.

5. Disconnect the clutch pedal-to-equalizer rod at the clutch pedal by removing the retainer and bushing.

6. Disconnect the stop light switch wires at the connector.

7. Remove the switch retainer and slide the stop light switch off the brake pedal pin **just far enough for the switch outer hole to clear the pin. Then lower the switch away from the pin.** Remove the master cylinder or booster push rod, bushing and nylon washer from the brake pedal pin.

8. Remove the screw retaining the pedal support bracket to the top inner cowl bracket (Figs. 12 and 15).

9. Remove the two sheet metal screws retaining the pedal support bracket to the dash panel. On power brakes remove the nuts from the brake booster studs.

10. Remove the two screws retaining the pedal support bracket to the upper cowl brace and lower the pedal support bracket away from the steering column studs.

11. Remove the pedal support bracket assembly from the vehicle.

12. Position the pedal and support bracket assembly in a vise.

13. Remove the C-clamp to release the clutch pedal from its bumper stop and pivot the pedal away from the bumper.

14. Remove the clutch pedal assist spring.

15. On non-power brakes, remove the retainer clip from the clutch and brake pedal shaft, then remove the clutch pedal and shaft assembly, the brake pedal assembly, and the bushings from the pedal support bracket. On power brakes, remove the retainer nut from the brake pedal shaft then remove the pedal shaft, the brake pedal assembly and the bushings from the pedal support bracket.

### Installation

1. Apply a coating of SAE 10 engine oil to the bushings and locate all bushings in their proper places on the clutch and brake pedal assemblies.

2. On non-power brakes, position the brake pedal to the pedal support bracket, then install the clutch pedal and shaft assembly through the support bracket and brake pedal assembly.

On power brakes position the brake pedal to the pedal support bracket, then install the pedal shaft and nut.

3. Install the clutch pedal assist spring and pivot the clutch pedal against its bumper stop. Secure the pedal to the stop with a small C-clamp as shown in Figs. 12 and 15.

4. Position the pedal support bracket assembly to the dash panel, and to the steering column retainer studs.

5. Align the pedal support bracket holes with the holes in the dash panel and install the two attaching sheet metal screws. On power brakes install the nuts on the brake booster studs.

6. Install the two cap screws attaching the pedal support bracket to the upper cowl bracket.

7. Install the cap screw attaching the pedal support bracket to the top inner cowl bracket (Figs. 12 and 15).

8. Install the inner nylon washer, the master cylinder push rod, and the bushing on the brake pedal pin. Position the stop light switch so that it straddles the push rod with the switch slot on the pedal pin and the switch outer hole just clearing the pin. Slide the switch completely onto the pin, and install the outer nylon washer as shown in Figs. 12 and 15. Secure these parts to the pin with the self-locking retainer.

9. Connect the stop light switch wires to the connector.

10. Connect the clutch pedal-to-equalizer rod to the clutch pedal assembly with the bushing and the spring clip retainer. Apply SAE 10 engine oil to the bushing. Remove the C-clamp from the clutch pedal.

11. Working from the engine side of the dash panel, on non-power brakes, install the two cap screws attaching the pedal support bracket to the dash panel. Then install the two screws attaching the master cylinder to the dash panel. On power brakes install the cap screws retaining the brake booster to the dash panel.

12. Install the steering column. Refer to Part 13-02 for procedure.

13. Adjust the clutch pedal free play (Group 16-02) to specification, if required.

14. Check the Brake Pedal Free Height and Travel Measurements Part 12-01.

15. Connect the ground cable to the battery.

## FAIRLANE, MONTEGO, FALCON, MAVERICK, MUSTANG AND COUGAR—AUTOMATIC TRANSMISSION

### Removal

1. Disconnect the stop light switch wires at the connector.

2. Remove the self-locking pin and slide the stop light switch off the brake pedal pin **just far enough for the switch outer hole to clear the pin.** Then lower the switch away from the pin. Slide the master cylinder or booster push rod and the nylon washers and bushing off from the brake pedal pin (Figs. 11, 12, 14 and 15).

3. On all vehicles except Mustang and Cougar with power brakes, remove the self-locking pin and washer from the brake pedal shaft, then remove the shaft, the brake pedal assembly and the bushings from the pedal support bracket. On Mustang and Cougar vehicles with power brakes, remove the locknut and bolt from the pedal. Remove the pedal assembly from the support bracket (Fig. 15).

### Installation

1. Apply a coating of SAE 10 engine oil to the bushings and locate all the bushings in their proper places on the pedal assembly and pedal support bracket (Figs. 11, 12, 14 and 15).

2. Position the brake pedal assembly to the support bracket, then install the pedal shaft or bolt through the support bracket and brake pedal assembly. Install the retainer or locknut.

3. Install the inner nylon washer, the master cylinder or booster push rod, and the bushing on the brake pedal pin. Position the switch so that it straddles the push rod with the switch slot on the pedal pin, and the switch outer hole just clearing the pin. Slide the switch completely onto the pin, and install the outer nylon washer as shown in Figs. 11, 12, 14 and 15. Secure these parts to the pin with the self-locking pin.

4. Connect the stop light switch wires to the connector, and install the wires in the retaining clip.

Check the Brake Pedal Free Height and Travel Measurements, Part 12-01.

**SATISFACTION 100% GUARANTEED**

**BUY IT NOW!**

**Click Here To Order**

PayPal American Express Discover MasterCard VISA

## 4 MAJOR REPAIR OPERATIONS

### BRAKE DRUM REFINISHING

Minor scores on a brake drum can be removed with sandpaper. A drum that is excessively scored or shows a total indicator runout of over 0.007 inch should be turned down. Remove only enough stock to eliminate the scores and true up the drum. The refinished diameter must not exceed 0.060 inch oversize.

Check the inside diameter of the brake drum with a brake drum micrometer (Tool FRE-1431).

If the drum diameter is less than 0.030 inch oversize after refinishing, standard lining may be installed. If the drum diameter is 0.030—0.060 inch oversize after refinishing, oversize lining must be installed.

After a drum is turned down, wipe the refinished surface with a cloth soaked in clean denatured alcohol. If one drum is turned down, the opposite drum on the same axle should also be cut down to the same size.

### BRAKE SHOE RELINING

Brake linings that are worn to within 1/32 inch of the rivet head or are less than 0.030 inch thick (bonded lining) or have been contaminated with brake fluid, grease or oil must be replaced. Failure to replace worn linings will result in a scored drum. When it is necessary to replace linings, they must also be replaced on the wheel on the opposite side of the vehicle.

Inspect brake shoes for distortion, cracks, or looseness. If this condition exists, the shoe must be discarded. Do not attempt to repair a defective brake shoe.

1. Wash the brake shoes thoroughly in a clean solvent. Remove all burrs or rough spots from the shoes.

2. Check the inside diameter of the brake drum with a brake drum micrometer (tool FRE-1431). If the diameter is less than 0.030 inches oversize, standard lining may be installed. If the diameter is 0.030—0.060 inches oversize, oversize lining should be installed.

3. Position the new lining on the shoe. Starting in the center, insert and secure the rivets, working alter-

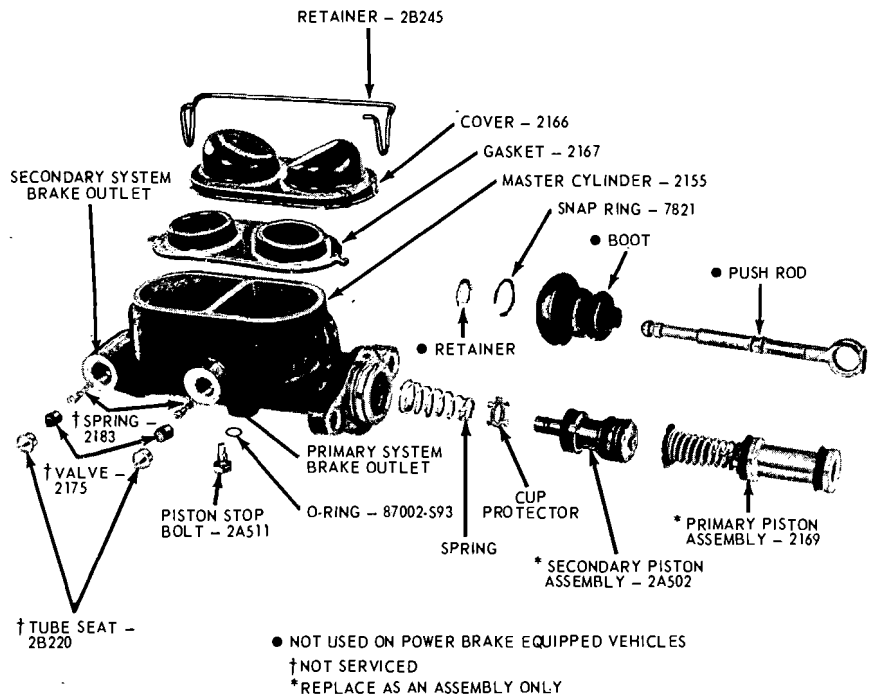

H 1499 - B

FIG. 16—Dual Master Cylinder Disassembled

shoe and lining. The lining must seat tightly against the shoe with not more than 0.008 inch clearance between any two rivets.

### DUAL MASTER CYLINDER

When a repair is necessary on the master cylinder, it is required practice during the warranty period to replace the cylinder as a unit instead of overhauling the cylinder with a service repair kit.

#### DISASSEMBLY

1. Clean the outside of the master cylinder and remove the filler cover and diaphragm. Pour out any brake fluid that remains in the cylinder. Discard the old brake fluid.

2. Remove the secondary piston stop bolt from the bottom of the cylinder (Fig. 16).

3. Remove the bleed screw, if required.

4. Depress the primary piston and remove the snap ring from the retaining groove at the rear of the master

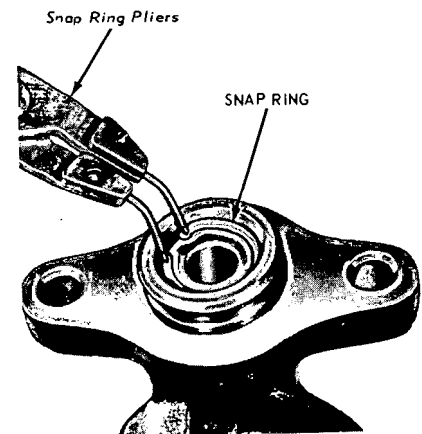

H1477-C

FIG. 17—Removing Snap Ring—Typical

cylinder bore (Fig. 17). Remove the push rod and the primary piston assembly from the master cylinder bore. Do not remove the screw that retains the primary return spring retainer, return spring, primary cup and protector on the primary piston. This assembly is factory pre-adjusted and

**100% GUARANTEED**

**BUY IT NOW!**

**Click Here To Order**

PayPal, American Express, Discover, MasterCard, VISA

should not be disassembled.

5. Remove the secondary piston assembly. **Do not remove the outlet tube seats, outlet check valves and outlet check valve springs from the master cylinder body.**

#### INSPECTION AND REPAIR

1. Clean all parts in clean isopropyl alcohol, and inspect the parts for chipping, excessive wear or damage. **When using a master cylinder repair kit, install all the parts supplied.**

2. Check all recesses, openings and internal passages to be sure they are open and free of foreign matter. Use an air hose to blow out dirt and cleaning solvent. Place all parts on a clean pan or paper.

3. Inspect the master cylinder bore

for signs of etching, pitting, scoring or rust. If it is necessary to hone the master cylinder bore to repair damage, do not exceed allowable hone specifications.

#### ASSEMBLY

1. Dip all parts except the master cylinder body in clean Rotunda Extra Heavy Duty Brake Fluid.

2. Carefully insert the complete secondary piston and return spring assembly in the master cylinder bore.

3. Install the primary piston assembly in the master cylinder bore.

4. Depress the primary piston and install the snap ring in the cylinder bore groove.

5. Install the push rod, boot and retainer on the push rod, if so

equipped. Install the push rod assembly into the primary piston. **Make sure the retainer is properly seated and holding the push rod securely.**

6. Position the inner end of the push rod boot (if so equipped) in the master cylinder body retaining groove.

7. Install the secondary piston stop bolt and O-ring in the bottom of the master cylinder.

8. Install the bleed screw (if so equipped). Install the gasket (diaphragm) in the master cylinder filler cover. Position the gasket as shown in Fig. 16. **Make sure the gasket is securely seated.**

9. Install the cover and gasket on the master cylinder and secure the cover into position with the retainer.

**SATISFACTION 100% GUARANTEED**

**BUY IT NOW!**

**Click Here To Order**

PayPal American Express Cards Discover Novus MasterCard VISA

## 5 SPECIFICATIONS

### LINING DIMENSIONS – DRUM BRAKES – INCHES

Vehicle	Position	Front	Rear
FORD, MERCURY, METEOR Ford, Meteor Passenger (Riveted Lining) Except 390, 429 CID Galaxie 500XL, Ford LTD, LeMoyné.	Primary	2.50 x 9.34	2.25 x 9.34
	Secondary	2.50 x 12.12	2.25 x 12.12
Ford, Mercury, Meteor with Disc Brakes.	Primary	N/A	2.25 x 9.34
	Secondary	N/A	2.25 x 12.12
Mercury Passenger, Sta. Wag. and Conv. Ford Meteor Station Wagon and Convertible. 390, 429 CID Galaxie 500 XL, Ford LTD, LeMoyné.	Primary	3.00 x 9.34	2.25 x 9.34
	Secondary	3.00 x 12.12	2.25 x 12.12
Ford, Meteor 240, 302 CID Taxi Only (Bonded Lining) Max Wear Resistance.	Primary	3.00 x 9.34	2.50 x 9.34
	Secondary	3.00 x 12.12	2.50 x 12.12
MONTEGO, FAIRLANE Passenger 250, 302 CID Except Convertible	Primary	2.25 x 8.43	2.00 x 8.43
	Secondary	2.25 x 10.82	2.00 x 10.82
Station Wagon, Rancho and Convertible 250, 302 CID. Passenger and Convertible 351, 390, 428 CID.	Primary	2.50 x 8.43	2.00 x 8.43
	Secondary	2.50 x 10.82	2.00 x 10.82
Station Wagon and Rancho 351, 390, 428 CID.	Primary	2.50 x 8.43	2.50 x 8.43
	Secondary	2.50 x 10.82	2.50 x 10.82
FALCON – MAVERICK Sedan 6-Cylinder.	Primary	2.25 x 7.62	1.50 x 7.62
	Secondary	2.25 x 9.77	1.50 x 9.77
Station Wagon 6-Cylinder.	Primary	2.50 x 8.43	2.00 x 8.43
	Secondary	2.50 x 10.82	2.00 x 10.82
Sedan 8-Cylinder.	Primary	2.25 x 8.43	2.00 x 8.43
	Secondary	2.25 x 10.82	2.00 x 10.82
Station Wagon 8-Cylinder.	Primary	2.50 x 8.43	2.00 x 8.43
	Secondary	2.50 x 10.82	2.00 x 10.75
MUSTANG, COUGAR 200 CID Engine.	Primary	2.25 x 7.62	1.50 x 7.62
	Secondary	2.25 x 9.77	1.50 x 9.77
250, 302 CID Engines.	Primary	2.25 x 8.43	1.75 x 8.43
	Secondary	2.25 x 10.82	1.75 x 10.82
351, 390, 428 CID Engines.	Primary	2.50 x 8.43	2.00 x 8.43
	Secondary	2.50 x 10.82	2.00 x 10.82
THUNDERBIRD, CONTINENTAL MARK III	Primary	N/A	2.25 x 9.34
	Secondary	N/A	2.25 x 12.12
LINCOLN CONTINENTAL	Primary	N/A	2.50 x 9.34
	Secondary	N/A	2.50 x 12.12

Wear Limits Riveted: 1/32 inch from top of rivets.  
Bonded: 0.030 inch total lining thickness.

CH1721-A



**BORE DIAMETERS—BRAKE DRUM, WHEEL CYLINDER AND MASTER CYLINDER**

	Models	Brake Drum		Wheel Cylinder Bore Dia.		Master Cylinder Bore Dia.	
		Inside Diameter	Boring Limit (Max.) <sup>①</sup>	Front <sup>②</sup>	Rear <sup>②</sup>	With Power Brake <sup>③</sup>	Less Power Brake <sup>③</sup>
Ford, Mercury and Meteor	Taxi and Station Wagon	11.030	11.090	1.094	0.938	1.000	1.000
	Other	11.030	11.090	1.125	0.938	1.000	1.000
Montego and Fairlane	Pass. except Conv. 250, 302 CID Engines	10.000	10.060	1.125	0.906	0.9375	1.000
	Pass. and Conv. 351, 390, 428 CID Eng.	10.000	10.060	1.125	0.906	0.9375	1.000
	Convertible 250, 302 CID Engines	10.000	10.060	1.125	0.906	0.9375	1.000
	Station and Ranchero	10.000	10.060	1.125	0.968	0.9375	1.000
Maverick Falcon	9 Inch Brake - Passenger Car	9.000	9.060	1.062 <sup>②</sup>	0.844 <sup>②</sup>	0.9375	1.000
	10 Inch Brake - Station Wagon	10.000	10.060	1.125	0.968	0.9375	1.000
	10 Inch Brake - Passenger Car	10.000	10.060	1.125	0.875	0.9375	1.000
Mustang and Cougar	200 CID Engine	9.000	9.060	1.062 <sup>②</sup>	0.844 <sup>②</sup>	1.000	1.000
	351, 390, 428 CID Engine	10.000	10.060	1.125	0.906	1.000	1.000
	250, 302, CID Engine	10.000	10.060	1.125	0.875	1.000	1.000
Thunderbird		11.030	11.090	N/A	0.938	N/A	N/A
Continental Mark III		11.030	11.090	N/A	0.938	N/A	N/A
Lincoln Continental		11.090	11.130	N/A	0.938	N/A	N/A

①Max. Runout 0.007  
 ②Max. Allowable Hone 0.003

③Front Wheel Cylinder cannot be honed on Falcon or Mustang with 9 inch Brakes.

CH1719-A

**100% SATISFACTION GUARANTEED**

**BUY IT NOW!**

**Click Here To Order**

PayPal American Express Discover MasterCard VISA

**TORQUE LIMITS-GENERAL-FT-LBS**

	Ford-Mercury Meteor	Fairlane-Montego Falcon Maverick	Mustang-Cougar	Thunderbird Continental Mark III	Lincoln Continental
Master Cylinder to Dash Panel Screw	13-25	13-25	13-25		
Master Cylinder to Booster	13-25	13-25	13-25	13-25	13-25
Booster to Dash Panel	13-25	13-25	13-25	13-25	13-25
Wheel Cylinder to Backing Plate Screws	10-20	10 in. Brake 10-20	10 in. Brake 10-20	10-20	10-20
		9 in. Brake 5-7	9 in. Brake 5-7		
Wheel Cylinder & Backing Plate Anchor Pin Nut	20-30				
Rear Brake Backing Plate to Axle Housing:	Removable Carrier			50-70	30-35
	Integral Type	20-40	20-40		
Front Brake Backing Plate to Spindle	25-40	20-35	20-35		
Pressure Differential Valve Bracket Bolts and Nuts	7-11	7-11	7-11	7-11	7-11
Wheel Cylinder Bleeder Screw	6-15	32-65Ⓞ Inch-lb.	32-65Ⓞ Inch-lb.	6-15	6-15
Brake Hose Connection to Front Wheel Cylinder	12-20	12-20	12-20		
Brake Line Connection to Rear Axle Housing:	Removable Carrier	12-19	12-19	30-40	
	Integral Type	25-35	12-19		
Hydraulic Tube ConnectionsⓄ	3/8 x 24	10-15	10-15	10-15	10-15
	7/18 x 24	10-15	10-15	10-15	10-15
	1/2 x 20	10-17	10-17	10-17	10-17
	9/16 x 18	10-17	10-17	10-17	10-17
Wheel to Hub and Drum	70-115	4 lug 55-85	4 lug 55-85	70-115	70-115
		5 lug 70-115	5 lug 70-115		

Ⓞ All hydraulic lines must be tightened to the specified torque value and be free of fluid leakage.

CH1720-A

**SPECIAL TOOLS**

Ford Tool No.	Former No.	Description
Rotunda HRE 8650		Brake Adjusting Gage
	LM 119	Brake Cylinder Retaining Clamp
	2018-A	Brake Adjusting Tool
	2162	Adapter Cap
	2035N	Brake Shoe R & R Spring
Tool 7000-00		Rubber Tipped Air Nozzle
Tool 33621	33621	Internal Snap Ring Pliers
	Milbar 1112-144	Inch Pound Torque Wrench
Tool 4235-C	4235-C	Axle Shaft Remover
Rotunda FRE 1431		Brake Drum Micrometer

CH1722-A

**100% SATISFACTION GUARANTEED**

**BUY IT NOW!**

**Click Here To Order**

PayPal American Express Discover MasterCard VISA

# PART 12-03 Disc Brake

COMPONENT INDEX Applies To Models As Indicated	All Models	Ford	Mercury	Meteor	Cougar	Fairlane	Montego	Mustang	Lincoln- Continental	Thunderbird	Continental- Mark III
<b>BRAKE BOOSTER</b>	03-03										
Cleaning and Inspection - See Part 12-01	01-08										
Description	03-03										
Removal and Installation	03-09										
<b>BRAKE PEDAL</b>											
Removal and Installation		03-10	03-10	03-10	03-10	03-10	03-10	03-10	03-12	03-11	03-11
<b>DISC BRAKE</b>	03-02										
Description	03-02										
<b>DISC BRAKE CALIPER</b>	03-02										
Cleaning and Inspection	03-14										
Disassembly and Overhaul	03-14										
Removal and Installation	03-04										
<b>DISC BRAKE ROTOR AND HUB</b>	03-03										
Cleaning and Inspection - See Part 12-01	01-07										
Refinishing	03-12										
Removal and Installation	03-06										
<b>DISC BRAKE ROTOR SPLASH SHIELD</b>	03-07										
Removal and Installation	03-07										
<b>DISC BRAKE SERVICE PRECAUTIONS</b>	01-07										
See Part 12-01	01-07										
<b>DISC BRAKE SHOE AND LINING</b>											
Cleaning and Inspection - See Part 12-01	01-07										
Removal and Installation		03-04	03-04	03-04	03-05	03-05	03-05	03-05	03-04	03-04	03-04
<b>DUAL BRAKE SYSTEM</b>	03-02										
Description	03-02										
<b>MASTER CYLINDER</b>	03-13										
Cleaning and Inspection	03-13										
Disassembly and Overhaul	03-13										
Removal and Installation - Power	03-07										
<b>PRESSURE DIFFERENTIAL AND PRESSURE CONTROL VALVE</b>	03-08										
Removal and Installation	03-08										
<b>PRESSURE METERING VALVE</b>		03-08	03-08	03-08	N/A	N/A	N/A	N/A	03-08	03-08	03-08
Removal and Installation		03-08	03-08	03-08	N/A	N/A	N/A	N/A	03-08	03-08	03-08

A page number indicates that the item is for the vehicle(s) listed at the head of the column.  
N/A indicates that the item is not applicable to the vehicle(s) listed.



# I DESCRIPTION

Disc brakes are available as optional equipment for the front wheels on Ford, Mercury, Meteor, Fairlane, Montego, Mustang and Cougar models and are standard on Thunderbird, Continental Mark III, and Lincoln Continental models. The dual-master

cylinder equipped hydraulic brake system employs single anchor, internal expanding and self-adjusting drum brake assemblies on the rear wheels of vehicles with disc brakes.

The disc brake consists of a ventilated rotor and caliper assembly. The caliper used is a single piston floating caliper (Fig. 1).

A pressure control valve provides balanced braking action between front and rear brakes.

On Ford, Mercury, Meteor, Continental Mark III, Lincoln Continental and Thunderbird models a metering valve, in the hydraulic line between the differential valve and the front wheel disc brakes, prevents the front brakes from applying until approximately 125 psi is obtained in the system (Fig. 1). This delaying action is required to prevent the front brakes from performing all the braking action on low speed stops and thereby increasing the rate of lining wear, and from locking on ice and slippery pavement.

A vacuum booster is used with the power disc brake system.

## DUAL MASTER CYLINDER BRAKE SYSTEM

The dual-master cylinder brake system has been incorporated in all models to provide increased safety. The system consists of a dual-master cylinder (Fig. 2), pressure differential valve assembly and a switch (Fig. 3). The switch on the differential valve activates a dual-brake warning light, located on the instrument panel.

## FLOATING CALIPER

The caliper assembly is made up of a floating caliper housing assembly and an anchor plate. The anchor plate is bolted to the wheel spindle arm by two bolts. The floating caliper is attached to the anchor plate by steel stabilizers on Ford, Mercury, Meteor, Lincoln Continental, Thunderbird and Continental Mark III models and by one stabilizer on Fairlane, Montego, Mustang and Cougar models. The floating caliper slides on two locating pins which also attach to the stabilizers. The floating caliper contains the

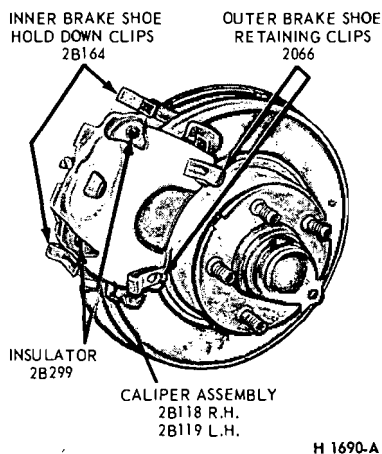
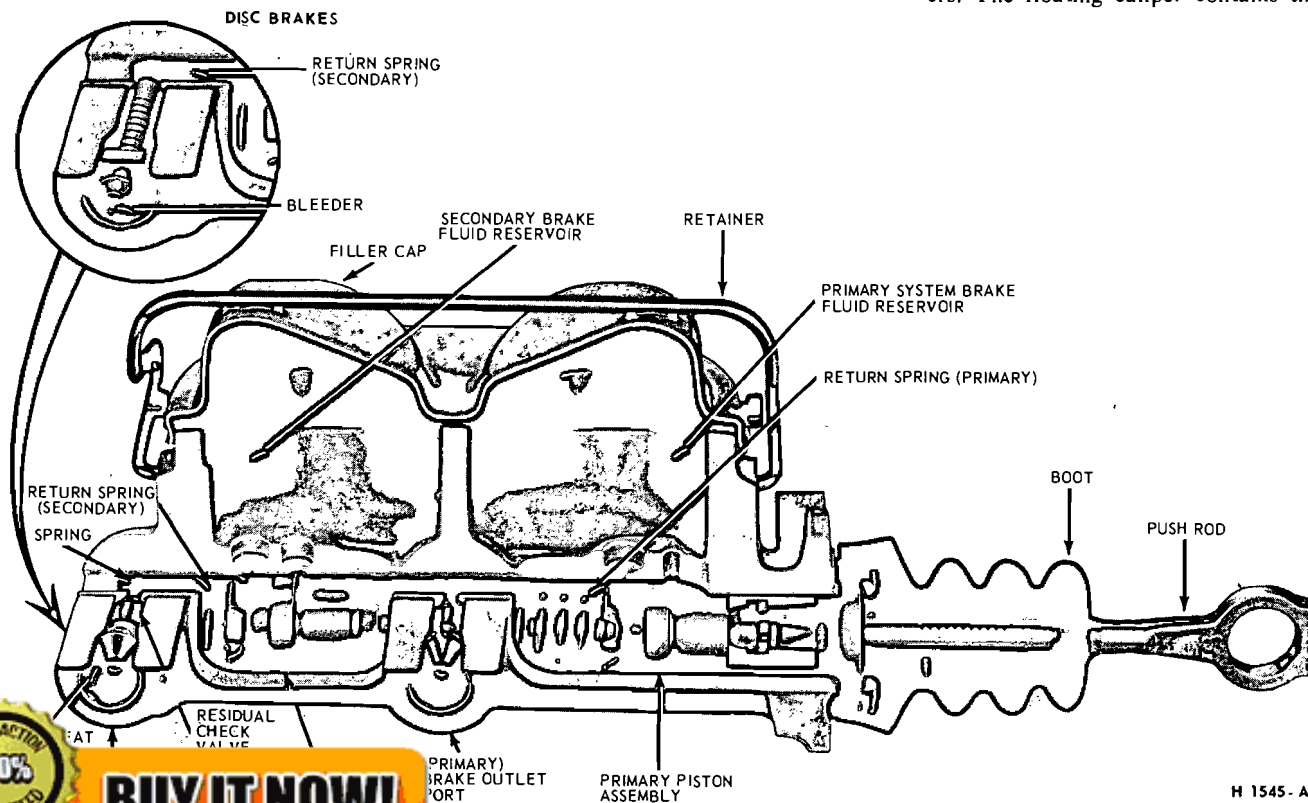

FIG. 1—Disc Brake Assembly—Floating Caliper



**100% SATISFACTION GUARANTEED**

**BUY IT NOW!**

**Click Here To Order**

icil

PayPal, American Express, Discover, MasterCard, VISA

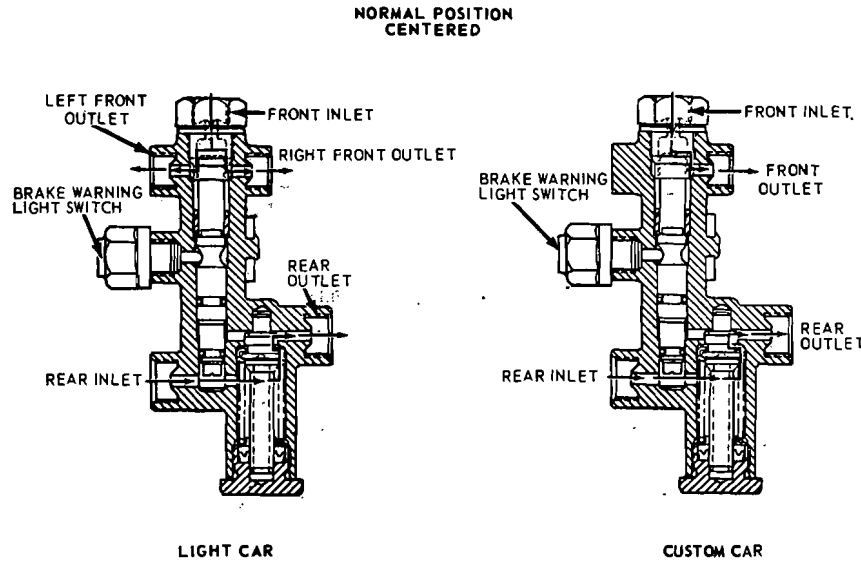

H1707-B

FIG. 3—Pressure Differential and Pressure Control Valve and Brake Warning Light Switch

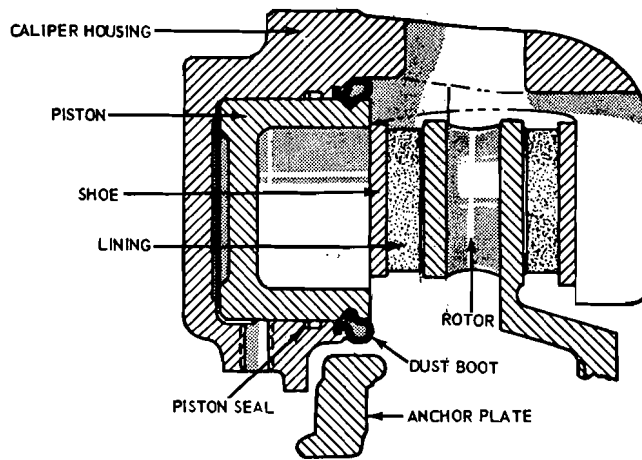

H 1568-B

FIG. 4—Floating Caliper Assembly—Sectional View

single cylinder and piston assembly. The cylinder bore contains a piston with a molded rubber dust boot to seal the cylinder bore from contamination (Fig. 4). A square section rubber piston seal is positioned in a groove in the cylinder bore and is used to provide sealing between the cylinder and piston (Fig. 5).

The outer brake shoe and lining assembly is longer than the inner assembly, and the shoe and lining assemblies are not interchangeable. The outboard shoe and lining is fixed to the floating caliper and is retained by two pins and spring clips. The shoe and lining assembly consists of friction material bonded to a metal plate called the shoe. It is replaced as a unit.

**ROTOR**

The cast iron disc is of the ventilated rotor-type incorporating forty fins and is attached to, and rotates with the wheel hub. A splash shield bolted to the spindle is used primarily to prevent road contaminants from contacting the inboard rotor and lining surfaces. The wheel provides protection for the outboard surface of the rotor.

**BRAKE BOOSTER SYSTEM**

This diaphragm-type brake booster is a self-contained vacuum-hydraulic braking unit mounted on the engine side of the dash panel.

The brake booster is of the vacuum suspended-type which utilizes engine intake manifold vacuum and atmospheric pressure for its power.

Adjustment of the push rod and replacement of the check valve and grommet are the only services permitted on the brake booster. The booster unit is to be exchanged when it is inspected, checked and found to be inoperative.

**100% SATISFACTION GUARANTEED**

**BUY IT NOW!**

**Click Here To Order**

PayPal, American Express, Discover, MasterCard, VISA

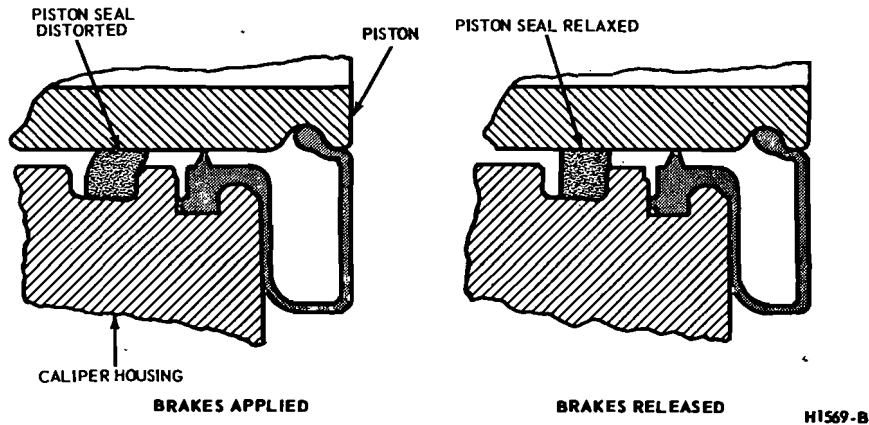

FIG. 5—Function of Piston Seal

## 2 REMOVAL AND INSTALLATION

### DISC BRAKE CALIPER ASSEMBLY

#### REMOVAL

1. Remove the wheel and tire assembly from the hub. Use care to avoid damage or interference with the bleeder screw fitting during removal.
2. Disconnect the brake hose from the caliper. Cap the hose fitting to prevent brake system contamination and loss of brake fluid from the master cylinder. Mark the left and right caliper assemblies with chalk prior to removal from the vehicle.
3. Remove the caliper locating pins and lower stabilizer attaching bolts and discard the stabilizer (Figs. 3 and 6).
4. Lift the caliper from the anchor plate.

#### INSTALLATION

1. Install the caliper assembly over the rotor with the outer brake shoe against the rotor braking surface during installation in the anchor plate to prevent pinching the piston boot between the inner brake shoe and the piston. Check that the correct caliper is installed on the correct anchor as marked during disassembly.

dirt. Torque the caliper locating pins to specifications.

3. Install the stabilizer to anchor plate attaching screws and torque to specifications.

4. Remove the cap from the brake hose fitting. Install a new copper washer on each side of the hose fitting and install the brake hose to the caliper. Torque the attaching bolt to specifications.

5. Bleed the brake system and centralize the brake pressure differential valve as outlined in Part 12-01.

6. Fill the master cylinder as required to within 1/4 inch of the top of the reservoir.

7. Install the wheel and tire assembly and torque the wheel nuts to specifications.

8. Apply the brake pedal prior to moving the vehicle to position the brake linings.

9. Road test vehicle.

### DISC BRAKE SHOE AND LINING

FORD, MERCURY, METEOR, THUNDERBIRD, CONTINENTAL MARK III, LINCOLN CONTINENTAL

#### Removal

1. Remove the master cylinder cap and check the fluid level in the primary (large) reservoir. Remove enough fluid until the reservoir is half

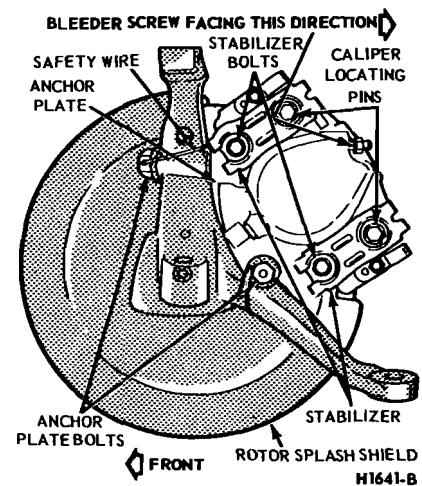

FIG. 6—Floating Caliper Installed—Rear View

full. Discard this fluid.

2. Remove the wheel and tire assembly from the hub. Be careful to avoid damage or interference with the caliper splash shield or bleeder screw fitting.

3. Remove the inner shoe hold down clips (Fig. 3).

4. Place a small screwdriver under the outer shoe retaining clip tang and lift away from the pin groove and slide the clip from the shoe retaining pin. Remove the other brake shoe retaining clip. See Fig. 3 and remove the outer brake shoe.

5. Remove the caliper locating pins

100% SATISFACTION GUARANTEED

**BUY IT NOW!**

Click Here To Order

PayPal Discover Novus MasterCard VISA

(Fig. 6).

6. Remove the upper stabilizer to anchor plate attaching bolt and remove the upper stabilizer to avoid interference with the brake hose during caliper removal (Fig. 6).

7. Lift the caliper assembly from the anchor plate and remove the outer shoe and retaining pins from the caliper assembly.

8. Suspend the caliper from the vehicle upper control arm with a wire hooked through the upper caliper locating pin hole.

9. Remove the caliper locating pin insulators (Fig. 3).

10. Remove the inner shoe and lining assembly and inspect both rotor braking surfaces.

**Installation**

1. Install the inner shoe and lining assembly in the anchor plate, then install new locating pin insulators (supplied in the shoe and lining kit). Use a cloth to protect the insulators during installation (Fig. 3). Check that both insulator flanges straddle the anchor plate.

2. Install the inner brake shoe hold down clips and torque the retaining bolts to specifications.

3. Install the piston retracting tool

in the caliper with the brake shoe lances positioned in the slots in the caliper outer legs and retract the piston (Fig. 7).

The piston retracting tool can be fabricated from a discarded outer brake shoe and a threaded rod. Refer to Fig. 8 for tool fabricating details.

When using the piston retracting tool, turn the threaded rod one half turn at a time and pause to permit the piston to move in the seal. Reduce the time interval as the piston nears the bottom of the cylinder bore to ensure bottoming of the piston. If the piston is not fully bottomed, the spacing between the linings will be insufficient to position the brake shoe and caliper assembly over the rotor.

Inspect the piston dust boot for cracks due to overheating and replace as required (Part 12-03, Section 4).

4. Turn the tool handle clockwise with one hand and guide the ram into the piston cavity with the other until the piston is bottomed in the cylinder bore. Remove the tool.

5. Install the outer brake shoe and lining assembly, then install the retaining pins and retainer clips (Fig. 3).

6. Remove the caliper assembly from the upper control arm and insert the caliper assembly in the anchor

plate.

7. Position the upper stabilizer and install the stabilizer to anchor plate attaching bolt. Be careful to properly position the tab at the lower bolt location. Torque the attaching bolt to specifications.

8. Install the caliper locating pins and torque to specifications (Fig. 6).

9. Add fluid in the master cylinder as required until the fluid level is within 1/4 inch of the top of the reservoir.

10. Install the wheel and tire assembly and torque the wheel nuts to specifications.

11. Pump the brake pedal prior to moving the vehicle to position the brake linings.

12. Road test the vehicle.

**FAIRLANE, MONTEGO, MUSTANG, COUGAR**

**Removal**

1. Remove the wheel and tire assembly from the hub. **Be careful to avoid damage or interference with the caliper splash shield or bleeder screw fitting.**

2. Remove the caliper from the vehicle following the procedures outlined under Disc Brake Caliper Assembly.

3. Remove the inner brake shoe hold down clips from the anchor plate, remove the locating pin insulators from the anchor plate and remove the inboard brake shoe and lining assembly.

4. To remove the outer brake shoe, place a small screwdriver under the outer brake shoe retaining clip tang

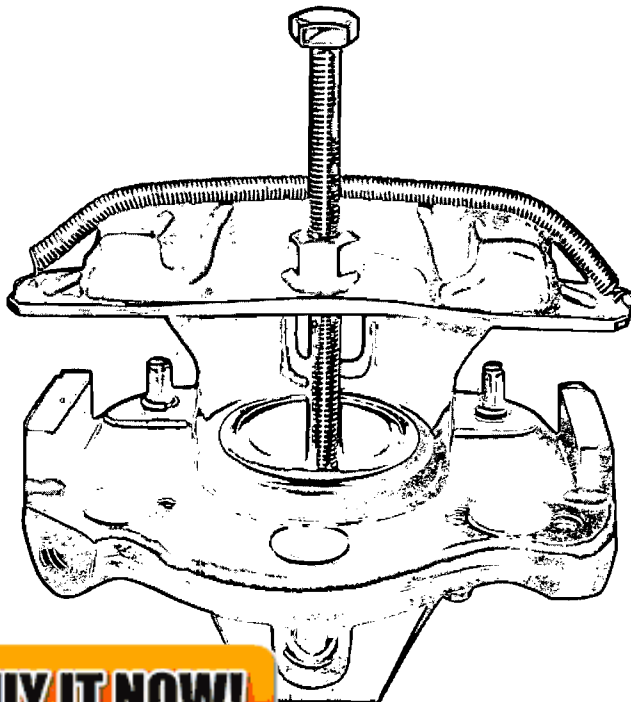

ing Tool

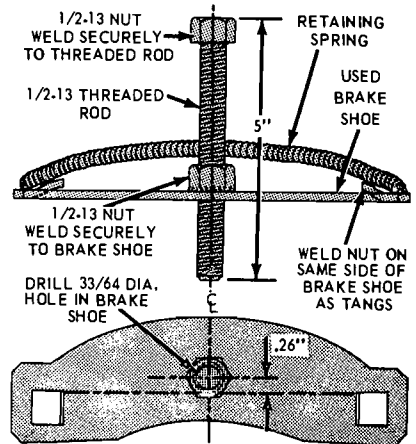

H 1693-A

FIG. 8—Piston Retracting Tool Dimensions

**100% SATISFACTION GUARANTEED**

**BUY IT NOW!**

**Click Here To Order**

PayPal, American Express, Discover, MasterCard, VISA

H 1691-A

and lift away from the pin groove and slide the clip from the brake shoe retaining pin. Remove the other brake shoe retaining clip. See Fig. 3 and remove the outer brake shoe.

**Installation**

1. To install a new inner brake shoe in the anchor plate, install new caliper locating pin insulators (supplied in the brake shoe and lining kit). Use a cloth to protect the insulators during assembly. Check that both insulator flanges straddle the anchor plate (See Fig. 3).

2. Install the inner brake shoe hold down clips and torque the retaining screws to specifications.

3. Install the piston retracting tool in the caliper with the brake shoe lances positioned in the slots in the caliper outer legs and retract the piston. The piston retracting tool can be fabricated from a discarded outer brake shoe and a threaded rod. Refer to Fig. 8 for tool fabricating details. When using the piston retracting tool, turn the threaded rod one half turn at a time and pause to permit the piston to move in the seal. Reduce the time interval to ensure bottoming of the piston. If the piston is not fully bottomed, the spacing between the linings is insufficient to assemble the brake shoe and caliper assembly over the rotor. Use a cloth to catch brake fluid from the caliper bore (See Fig. 7).

4. Install the new outer brake shoe and lining assembly on the caliper and install the outer brake shoe retaining clips. Hold the retaining pins in position with an allen wrench or bolt while installing the retaining clips.

5. Install the caliper on the vehicle following the procedures outlined under Disc Brake Caliper Assembly.

**FRONT WHEEL HUB AND ROTOR ASSEMBLY**

**REMOVAL**

1. Remove the wheel and tire from the hub. **Be careful to avoid damage or interference with the bleeder screw fitting.**

2. Remove the caliper assembly from the spindle and the rotor. If the caliper does not require servicing, it is not necessary to disconnect the brake hose or remove the caliper from the vehicle. Position the caliper out of the way, and support it with a wire to avoid damaging the caliper or stretching the hose. Insert a clean cardboard spacer between the linings to prevent the piston from coming out of the cylinder bore while the caliper is removed.

**Handle the rotor and caliper assemblies in such a way as to avoid deformation of the rotor and nicking, scratching or contamination of the brake linings.**

3. Remove the grease cap from the

hub. Remove the cotter pin, nut lock, adjusting nut, and flat washer from the spindle. Remove the outer bearing cone and roller assembly.

4. Remove the hub and rotor assembly from the spindle.

**INSTALLATION**

1. If the rotor is being replaced, remove the protective coating from the new rotor with carburetor degreaser. Pack a new set of bearings with specified grease (M-1C75B), and install the inner bearing cone and roller assembly in the inner cup. Pack grease lightly between the lips of a new grease seal and install the seal (Fig. 9).

If the original rotor is being installed, make sure that the grease in the hub is clean and adequate, that the inner bearing and grease seal are lubricated and in good condition, and that the rotor braking surfaces are clean.

2. Install the hub and rotor assembly on the spindle.

3. Lubricate and install the outer wheel bearing, washer and adjusting nut.

4. Adjust the wheel bearings to specification, and then install the nut lock, cotter pin, and grease cap. **The wheel bearing adjustment is especially important with disc brakes.**

5. Mount the caliper assembly on the spindle following the Disc Brake Caliper Assembly Installation proce-

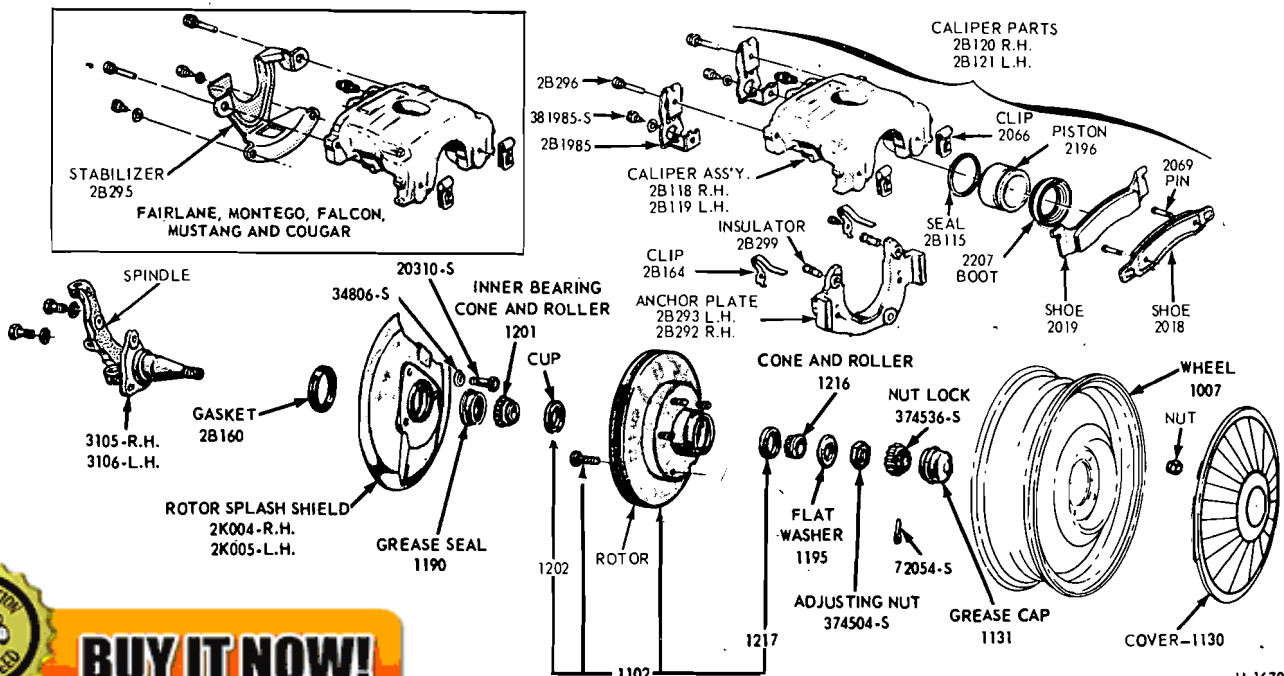

H 1670-A

**100% GUARANTEED**

**BUY IT NOW!**

**Click Here To Order**

PayPal, American Express, Discover, MasterCard, VISA

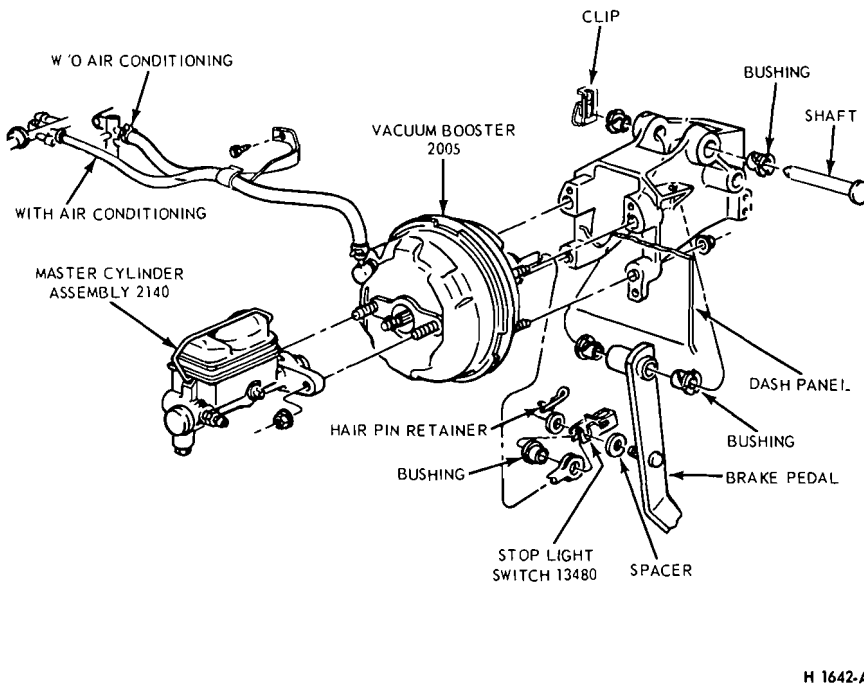

FIG. 10—Master Cylinder Installation—Power Brake—Ford, Mercury and Meteor

ture in this section.

**DISC BRAKE ROTOR SPLASH SHIELD**

**REMOVAL**

1. Remove the caliper and the hub and rotor assembly as outlined under Removal in the foregoing procedure (it is not necessary to disconnect hydraulic connections).
2. Remove the three bolts that attach the splash shield to the spindle, and remove the shield (Fig. 9).
3. Remove and discard the splash shield to spindle gasket.

**INSTALLATION**

1. Install a new splash shield to spindle gasket.
2. If the shield is bent, straighten it out before installation. Position the shield to the mounting bracket, install the attaching bolts, nuts and torque them to specification.
3. Install the hub and rotor assembly and the caliper as outlined under Installation in the foregoing procedure.

**DUAL MASTER CYLINDER—POWER BRAKES**

**REMOVAL**

1. Remove the brake tubes from the primary and secondary outlet ports of the master cylinder (Figs. 29 thru 33).
2. Remove the two nuts and two lock washers attaching the master cylinder to the brake booster assembly.
3. Slide the master cylinder forward and upward from the vehicle.

**INSTALLATION**

1. Before installing the master cylinder, check the distance from the outer end of the booster assembly push rod to the master cylinder mounting surface. Turn the push rod adjusting screw in or out as required to obtain the specified length. Refer to Part 12-01, Section 2, Power Brake Master Cylinder Push Rod Adjustment for the proper procedure.
2. Position the master cylinder assembly over the booster push rod and onto the two studs on the booster assembly (Figs. 10 thru 14).
3. Install the attaching nuts and lock washers and torque them to specifications.

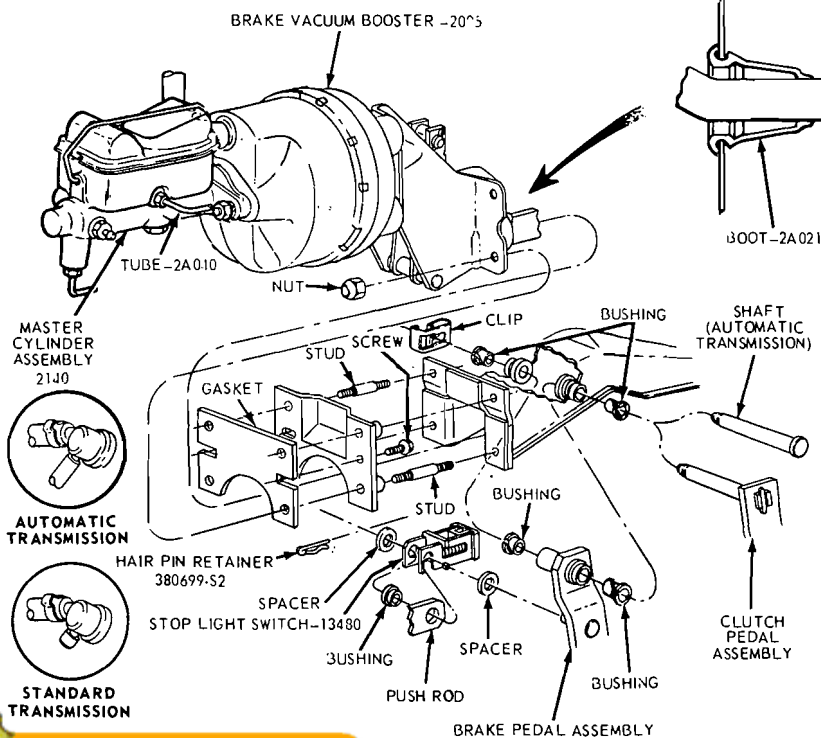

ation—Power Brake—Fairlane,

**100% SATISFACTION GUARANTEED**

**BUY IT NOW!**

**Click Here To Order**

PayPal, American Express, Discover, MasterCard, VISA

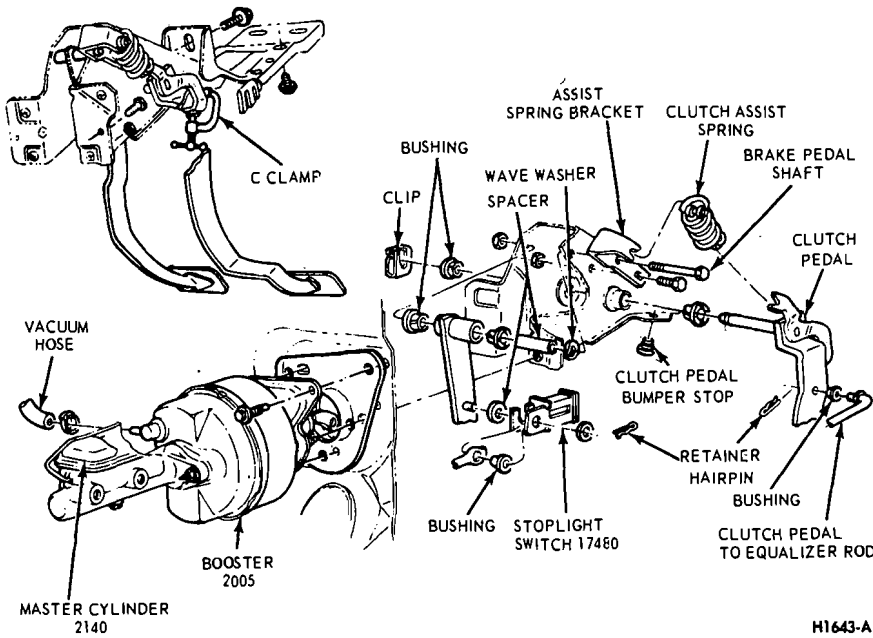

FIG. 12—Master Cylinder Installation—Power Brake—Mustang and Cougar

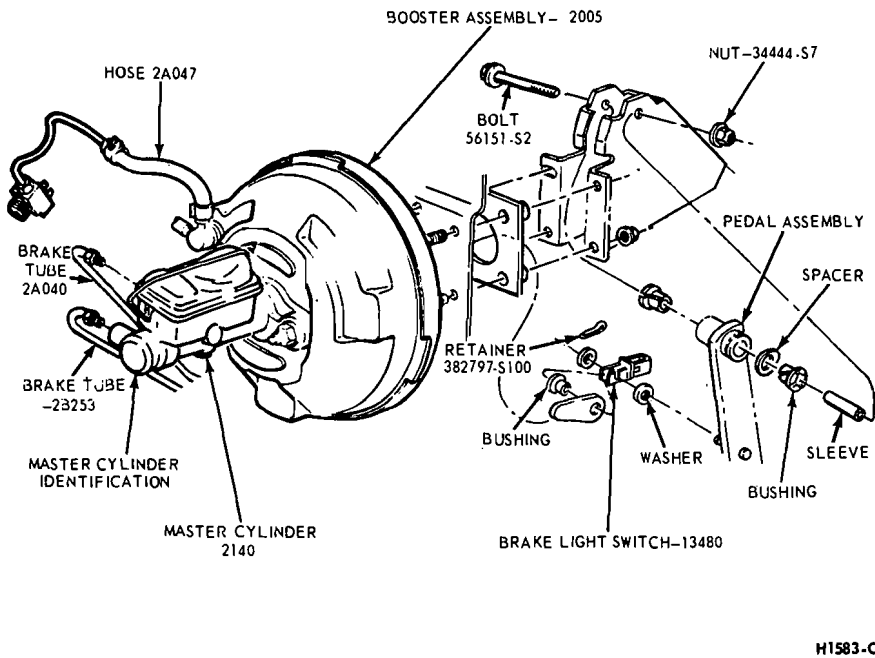

FIG. 13—Master Cylinder Installation—Thunderbird and Continental Mark III

(ESA-M6C25-A) for all brake applications. The extra heavy duty brake fluid is colored blue for identification. Do not mix low temperature brake fluids with the specified fluids for the disc brake system.

6. Bleed the dual-master cylinder and the primary and secondary brake systems. Centralize the pressure differential valve. Refer to Hydraulic System Bleeding and Centralizing of the Differential Valve, Part 2-1, Section 2 for the proper procedure.

7. Operate the brakes several times, then check for external hydraulic leaks.

**PRESSURE DIFFERENTIAL AND PRESSURE CONTROL VALVE**

**REMOVAL**

Refer to Fig. 2.

The Brake and/or Pressure Differential and Pressure Control Valve assembly is serviced as an assembly only. Do not attempt to repair this unit.

1. Disconnect the brake warning light connector from the warning light switch.

2. Disconnect the front inlet and rear outlet tubes from the valve assembly (Fig. 2).

3. Remove the two attaching nuts and bolts from the valve bracket on the underside of the fender apron and remove the valve assembly and bracket from the vehicle.

**INSTALLATION**

1. Position the valve assembly and bracket to the fender apron. Install the attaching nuts and bolts. Torque them to specifications.

2. Install the front inlet and rear outlet tubes to the valve assembly. Torque them to specifications.

3. Connect the brake warning light connector to the warning light switch.

4. Bleed the system and centralize the pressure differential valve following the procedures in Centralizing the Pressure Differential Valve.

**PRESSURE METERING VALVE—FORD, MERCURY, METEOR, CONTINENTAL MARK III, THUNDERBIRD, LINCOLN CONTINENTAL**

**REMOVAL**

Refer to Fig. 15.

1. Loosen the tube nuts connecting the inlet and outlet tubes at the me-

specified brake fluid to within 1/4 inch of the top of the dual reservoirs. Use Ford Brake Fluid—Extra Heavy Duty—Part Number C6AZ-19542-A

**100% SATISFACTION GUARANTEED**

**BUY IT NOW!**

**Click Here To Order**

PayPal, American Express, Discover, MasterCard, VISA

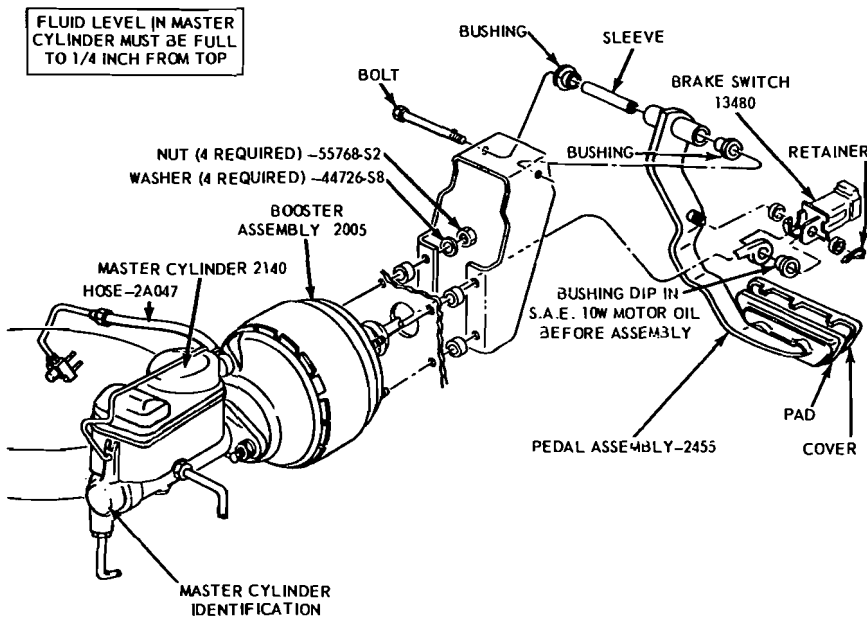

H1530-D

FIG. 14—Master Cylinder Installation—Lincoln Continental

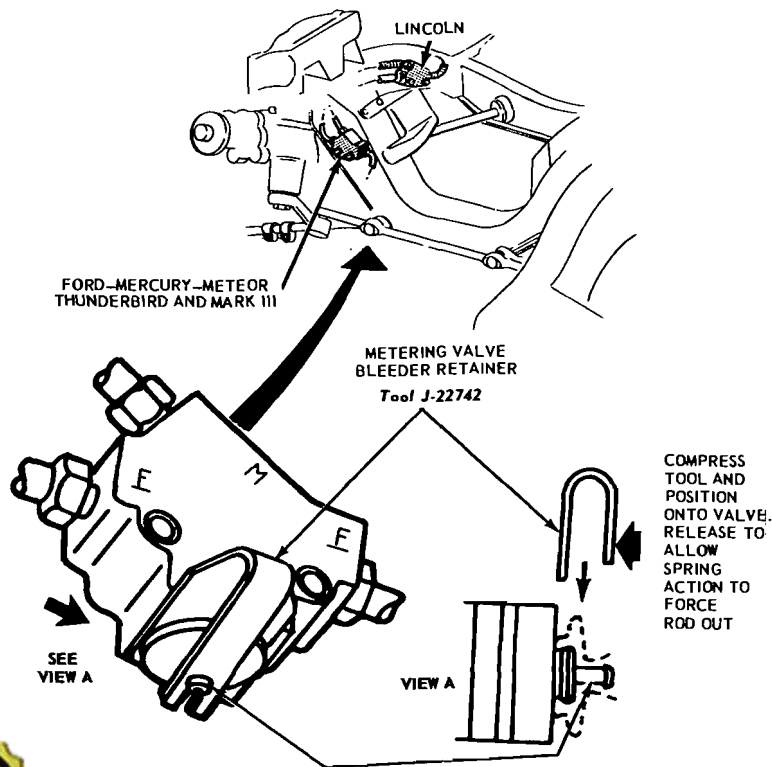

H1644-B

tering valve, and remove the tubes.

2. Remove the two screws retaining the metering valve to the frame crossmember, and remove the metering valve. The metering valve is serviced as an assembly only.

**INSTALLATION**

1. Position the metering valve to the frame crossmember, and install the retaining screws.

2. Connect the inlet and outlet tubes to the metering valve, and tighten the tube nuts to specification.

3. Pressure Bleed the system.

**BRAKE BOOSTER**

**REMOVAL**

1. Working from inside the vehicle below the instrument panel, disconnect the booster push rod from the brake pedal assembly. To do this, proceed as follows:

Disconnect the stop light switch wires at the connector. Remove the hairpin retainer. Slide the stop light switch off from the brake pedal pin just far enough for the switch outer hole to clear the pin, and then remove the switch from the pin and booster push rod. Be careful not to damage the switch during removal. Slide the booster push rod and the nylon washers and bushing off the brake pedal pin (Figs. 10 thru 14).

2. Open the hood and remove the master cylinder from the booster. Secure it to one side without disturbing the hydraulic lines. It is not necessary to disconnect the brake lines, but care should be taken that the brake lines are not deformed. Permanent deformation of brake lines can lead to tube failure.

3. Disconnect the manifold vacuum hose or hoses from the booster unit.

4. Remove the booster-to-dash panel attaching nuts or bolts (Figs. 10 thru 14). Remove the booster and bracket assembly from the dash panel, sliding the push rod link out from the engine side of the dash panel.

5. On Fairlane, Montego, and Falcon models, remove the push rod link boot from the dash panel.

**INSTALLATION**

1. On Fairlane, Montego and Falcon models, install the push rod link boot in the hole in the dash panel as shown in Fig. 11. Install the four spacers on the mounting studs.

**100% SATISFACTION GUARANTEED**

**BUY IT NOW!**

**Click Here To Order**

PayPal, American Express, Discover, MasterCard, VISA

2. Mount the booster and bracket assembly to the dash panel by inserting the push rod or push rod link in through the hole and boot in the dash panel. Install the bracket-to-dash panel attaching lock nuts or bolts (Figs. 10 thru 14).

3. Connect the manifold vacuum hose or hoses to the booster.

4. Before installing the master cylinder, check the distance from the outer end of the booster assembly push rod to master cylinder surface. Turn the screw in or out to obtain the specified length. Refer to Part 12-01, Section 2, Power Brake Master Cylinder Push Rod Adjustment. Install the master cylinder and torque the attaching nuts to specifications.

5. Working from inside the vehicle below the instrument panel, connect the booster push rod link to the brake pedal assembly. To do this, proceed as follows:

Install the inner nylon washer, the booster push rod, and the bushing on the brake pedal pin. Position the switch so that it straddles the push rod with the switch slot on the pedal pin and the switch outer hole just clearing the pin. Slide the switch completely onto the pin, and install the nylon washer as shown in Figs. 10 thru 14. **Be careful not to bend or deform the switch.** Secure these parts to the pin with the hairpin retainer. Connect the stop light switch wires to the connector, and install the wires in the retaining clip.

## BRAKE PEDAL

### FORD, MERCURY AND METEOR

#### Removal

1. Disconnect the stop light switch wires at the connector.

2. Remove the hairpin retainer. Slide the stop light switch off the brake pedal pin **just far enough for the switch outer hole to clear the pin**, and then lift the switch straight upward from the pin. **Be careful not to damage the switch during removal.** Slide the master cylinder or booster push rod and the nylon washers and bushing off the brake pedal pin (Fig.

Remove the hairpin-type retain-

## Installation

1. Apply a coating of SAE 10 Engine oil to the bushings and locate bushings in their proper places on the pedal assembly and pedal support bracket (Fig. 10).

2. Position the brake pedal assembly to the support bracket, then install the pedal shaft through the support bracket and brake pedal assembly. Install the retainer.

3. Install the inner nylon washer, the master cylinder or booster push rod, and the bushing on the brake pedal pin. Position the switch so that it straddles the push rod with the switch slot on the pedal pin and the switch outer hole just clearing the pin. Slide the switch completely onto the pin, and install the nylon washer as shown in Fig. 10. **Be careful not to bend or deform the switch.** Secure these parts to the pin with the hairpin retainer.

4. Connect the stop light switch wires to the connector, and install the wires in the retaining clip.

5. Check the Brake Pedal Free Height and Travel Measurements, Part 12-01, Section 1.

### FAIRLANE, MONTEGO—MANUAL- SHIFT-TRANSMISSION

#### Removal

1. Remove the clutch pedal assist spring.

2. Disconnect the clutch pedal-to-equalizer rod at the clutch pedal by removing the retainer and bushing.

3. Disconnect the stop light switch wires at the connector.

4. Remove the switch retainer, and slide the stop light switch off the brake pedal pin **just far enough for the switch outer hole to clear the pin. Then lower the switch away from the pin.**

5. Slide the master cylinder or booster push rod and the nylon washers and bushing off from the brake pedal pin (Fig. 11).

6. Remove the self-locking pin and washer from the clutch and brake pedal shaft, then remove the clutch pedal and shaft assembly, the brake pedal assembly, and the bushings from the pedal support bracket (Fig. 11).

#### Installation

1. Apply a coating of SAE 10 engine oil to the bushings and locate

all bushings in their proper places on the clutch and brake pedal assemblies.

2. Position the brake pedal to the support bracket, then install the clutch pedal and shaft assembly through the support bracket and brake pedal assembly. Install the spring clip (Figs. 27 and 30).

3. Install the clutch pedal assist spring.

4. Connect the clutch pedal-to-equalizer rod to the clutch pedal assembly with the bushing and the spring clip retainer. Apply SAE 10 engine oil to the bushing.

5. Install the inner nylon washer, the master cylinder or booster push rod, and the bushing on the brake pedal pin. Position the switch so that it straddles the push rod with the switch slot on the pedal pin and the switch outer hole just clearing the pin. Slide the switch completely onto the pin, and install the outer nylon washer as shown in Fig. 11. Secure these parts to the pin with the self-locking pin.

6. Connect the stop light switch wires to the connector, and install the wires to the retaining clip.

7. Adjust the clutch pedal free play (Group 16-02) to specification, if required.

8. Check the Brake Pedal Free Height and Travel Measurements (Part 12-01, Section 1).

### MUSTANG AND COUGAR— MANUAL-SHIFT TRANSMISSION

#### Removal

1. Disconnect the battery ground cable from the battery.

2. Remove the steering column. Refer to Part 13-02 for procedure.

2. Remove the two cap screws retaining the booster to the dash panel.

4. Working inside the vehicle, secure the clutch pedal against the bumper stop with a small C-clamp as shown in Fig. 12.

5. Disconnect the clutch pedal-to-equalizer rod at the clutch pedal by removing the retainer and bushing.

6. Disconnect the stop light switch wires at the connector.

7. Remove the switch retainer and slide the stop light switch off the brake pedal pin **just far enough for the switch outer hole to clear the pin. Then lower the switch away from the pin.** Remove the master cylinder or booster push rod, bushing and nylon washer from the brake pedal pin.

Remove the hairpin-type retain-

**BUY IT NOW!**

Click Here To Order

PayPal American Express Discover MasterCard VISA

8. Remove the screw retaining the pedal support bracket to the top inner cowl bracket (Fig. 12).

9. Remove the two sheet metal screws retaining the pedal support bracket to the dash panel. On power brakes remove the nuts from the brake booster studs.

10. Remove the two screws retaining the pedal support bracket to the upper cowl brace and lower the pedal support bracket away from the steering column studs.

11. Remove the pedal support bracket assembly from the vehicle.

12. Position the pedal and support bracket assembly in a vise.

13. Remove the C-clamp to release the clutch pedal from its bumper stop and pivot the pedal away from the bumper.

14. Remove the clutch pedal assist spring.

15. Remove the clutch pedal and shaft assembly, the brake pedal assembly, and the bushings from the pedal support bracket. Remove the retainer nut from the brake pedal shaft then remove the pedal shaft, the brake pedal assembly and the bushings from the pedal support bracket.

### Installation

1. Apply a coating of SAE 10 engine oil to the bushings and locate all bushings in their proper places on the clutch and brake pedal assemblies.

2. Install the clutch pedal and shaft assembly through the support bracket and brake pedal assembly. On power brakes position the brake pedal to the pedal support bracket, then install the pedal shaft and nut.

3. Install the clutch pedal assist spring and pivot the clutch pedal against its bumper stop. Secure the pedal to the stop with a small C-clamp as shown in Fig. 12.

4. Position the pedal support bracket assembly to the dash panel, and to the steering column retainer studs.

5. Align the pedal support bracket holes with the holes in the dash panel and install the two attaching sheet metal screws. Install the nuts on the brake booster studs.

6. Install the two cap screws attaching the pedal support bracket to the upper cowl bracket.

bushing on the brake pedal pin. Position the stop light switch so that it straddles the push rod with the switch slot on the pedal pin and the switch outer hole just clearing the pin. Slide the switch completely onto the pin, and install the outer nylon washer as shown in Fig. 12. Secure these parts to the pin with the self-locking retainer.

9. Connect the stop light switch wires to the connector.

10. Connect the clutch pedal-to-equalizer rod to the clutch pedal assembly with the bushing and the spring clip retainer. Apply SAE 10 engine oil to the bushing. Remove the C-clamp from the clutch pedal.

11. Working from the engine side of the dash panel. Install the cap screws retaining the brake booster to the dash panel.

12. Install the steering column. Refer to Part 13-02 for procedure.

13. Adjust the clutch pedal free play (Part 16-02) to specifications, if required.

14. Check the Brake Pedal Free Height and Travel Measurements (Part 12-01, Section 1).

15. Connect the ground cable to the battery.

### FAIRLANE, MONTEGO, MUSTANG AND COUGAR—AUTOMATIC TRANSMISSION

#### Removal

1. Disconnect the stop light switch wires at the connector.

2. Remove the self-locking pin and slide the stop light switch off the brake pedal pin **just far enough for the switch outer hole to clear the pin**. Then lower the switch away from the pin. Slide the master cylinder or booster push rod and the nylon washers and bushing off from the brake pedal pin (Fig. 12).

3. On all vehicles except Mustang and Cougar, remove the self-locking pin and washer from the brake pedal shaft, then remove the shaft, the brake pedal assembly and the bushings from the pedal support bracket. On Mustang and Cougar vehicles, remove the locknut and bolt from the pedal. Remove the pedal assembly from the support bracket (Fig. 12).

#### Installation

1. Apply a coating of SAE 10 engine oil to the bushings and locate all the bushings in their proper places

on the pedal assembly and pedal support bracket (Fig. 12).

2. Position the brake pedal assembly to the support bracket, then install the pedal shaft or bolt through the support bracket and brake pedal assembly. Install the retainer or locknut.

3. Install the inner nylon washer, the master cylinder or booster push rod, and the bushing on the brake pedal pin. Position the switch so that it straddles the push rod with the switch slot on the pedal pin, and the switch outer hole just clearing the pin. Slide the switch completely onto the pin, and install the outer nylon washer as shown in Fig. 12. Secure these parts to the pin with the self-locking pin.

4. Connect the stop light switch wires to the connector, and install the wires in the retaining clip.

Check the Brake Pedal Free Height and Travel Measurements, Part 12-01, Section 1.

### THUNDERBIRD AND CONTINENTAL MARK III

#### Removal

1. Loosen the booster mounting nuts.

2. Disconnect the stop light switch wires at the connector.

3. Remove the hairpin retainer. Slide the stop light switch off from the brake pedal pin **just far enough for the switch outer hole to clear the pin**, and then lift the switch straight upward from the pin. Slide the master cylinder push rod and the nylon washers and bushing off from the brake pedal pin (Fig. 13).

4. Remove the pivot bolt and nut that holds the pedal to the pedal support bracket. Remove the brake pedal assembly from the pedal support bracket, and remove the bushings.

#### Installation

1. Apply a coating of SAE 10 engine oil to the bushings and locate all the bushings in their proper places on the pedal assembly (Fig. 13).

2. Install the brake pedal assembly and bushings to the support bracket, and then install the pivot bolt through the support bracket and brake pedal assembly. Install the pivot bolt nut and torque to specifications.

3. Install the inner nylon washer, the master cylinder push rod, and the bushing on the brake pedal pin. Position the switch so that it straddles the

**SATISFACTION 100% GUARANTEED**

**BUY IT NOW!**

Click Here To Order

PayPal American Express Discover Novus MasterCard VISA

push rod with the switch slot on the pedal pin and the switch outer hole just clearing the pin. Slide the switch completely onto the pin, install the outer nylon washer as shown in Fig. 13. Secure these parts to the pin with the hairpin retainer.

4. Connect the stop light switch wires to the connector, and install the wires in the retaining clip.

5. Torque the booster mounting nuts to specifications.

## LINCOLN CONTINENTAL

### Removal

1. Disconnect the battery ground cable from the battery.

2. It is necessary to obtain clearance to remove vacuum hoses and the electrical connector to the temperature heat control box. Remove the two screws retaining the relay to the fender and push the relay aside. Disconnect the vacuum hoses and connector at the heat control box.

3. Working under the instrument panel, disconnect the vacuum hoses, wires and retaining clip from the temperature heat control box. Remove the two screws securing the temperature control box to the dash panel.

4. Remove the lower control housing retaining screws (6). Disconnect the wire harnesses at the lower control panel and place the panel aside. Remove the wire harness shield. Remove the wire harness clip. Position

the wire harness aside. Remove the temperature control box and position it aside.

5. Remove the hair-pin type retainer. Slide the stop light switch off the brake pedal pin just far enough for the switch outer hole to clear the pin. Lift the switch upward from the pin. Slide the master cylinder push rod, nylon washers and bushing off the brake pedal pin.

6. Remove the pivot bolt and nut that holds the pedal to the pedal support bracket. Remove the brake pedal assembly from the support bracket and remove the bushings.

7. If required, remove the brake pedal pad retaining nuts and remove the brake pedal pad.

### Installation

1. If the brake pedal pad was removed, position the pad on the pedal. Install the pad retaining nuts and torque them to specification.

2. Apply SAE 10 engine oil to the bushings and locate all the bushings in their proper places on the pedal assembly.

3. Install the brake pedal assembly and bushings to the support bracket, and then install the pivot bolt through the support bracket and pedal assembly. Install the pivot bolt nut and torque it to specification.

4. Install the inner nylon washer, the master cylinder push rod link, and the

bushing on the brake pedal pin. Position the switch so that it straddles the push rod link with the switch slot on the pedal and the switch outer hole just clearing the pin. Install the outer nylon washer as shown in Fig. 14. Install the hair-pin type retainer on the brake pedal pin.

5. Connect the stop light switch wires to the connector, and install the wires in the retaining clip.

6. Position the wire harness and clip on the temperature control box and install the retaining screw. Position the temperature control box to the dash panel and install the two retaining bolts.

7. Connect the vacuum lines and the electrical connector to the control box. Position the wire harness to the control box and install the retaining clip.

8. Position the wire harness shield and install two retaining bolts.

9. Connect the wire harnesses to the lower control panel and install the retaining screws.

10. Working within the engine compartment, connect the wire connector to the temperature heat control box.

11. Position the relay to the fender apron and install the retaining bolts.

12. Connect the ground cable to the battery.

13. Check the brakes and light switch for proper operation. Close the hood.

## 3 MAJOR REPAIR OPERATIONS

After any service work, obtain a firm brake pedal before moving the vehicle. Riding the brake pedal (common on left foot application) should be avoided when driving the vehicle.

### ROTOR REFINISHING

Rotunda Disc Brake Attachment, FRE-2249-2, is the only recommended tool to refinish the disc brake rotors. The step-by-step resurfacing procedure provided with the tool must be adhered to.

The finished braking surfaces of the

ish of the braking surfaces are to be 80/15 micro inches. The minimum limiting dimensions (Fig. 16) from the inboard bearing cup to the outboard rotor face and from the inboard bearing cup to the inboard rotor face must be observed when removing material from the rotor braking surfaces. On all models the limiting dimensions are to be measured with the ball and gage bar (Rotunda Kit FRE-70160).

### DISC BRAKE ROTOR CHECK

Refer to Fig. 16.

A ball and gauge bar are required to measure wear on the rotor inner braking surface and to determine the maximum stock removal limit when

brake rotors require refinishing. Gauging of the rotor is accomplished on the bench prior to mounting in a rotor lathe. A controlled dimension notch machined in one edge of the gauge bar identified **custom car** (Ford, Mercury, Meteor and Thunderbird, Continental Mark III and Lincoln Continental). The opposite raised center of the gauge bar is identified **light car** (Montego, Fairlane, Mustang and Cougar). Refer to Fig. 16.

Gauging of the rotor is accomplished according to the following procedure:

1. Remove the inner bearing assembly and grease retainer and thoroughly clean the inner bearing cup and hub bore.

100% SATISFACTION GUARANTEED

**BUY IT NOW!**

Click Here To Order

PayPal American Express Discover MasterCard VISA

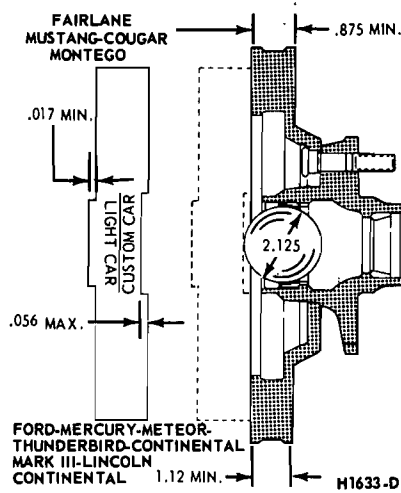

FIG. 16—Disc Brake Rotor Service Limits

2. Carefully place the gauge ball in the inner bearing cup (Do not drop).
3. Position the gauge bar across the rotor inner braking surface and over the gauge ball (Fig. 16). Measure the distance between the gauge bar and ball. This clearance is equal to the maximum allowable stock removal. If the gauge bar touches the ball, no additional stock removal is allowed. If the gauge bar is below the top of the ball, the rotor must be replaced.
4. The rotor thickness dimensions after refinishing are limited to the minimum measurements shown below.

Ford, Mercury, Meteor, Thunderbird, Continental Mark III and Lincoln Continental 1.120-inch minimum.  
 Fairlane, Montego, Mustang and Cougar 0.875-inch minimum.

**Rotors having a thickness less than above specifications must be replaced regardless of the ball and gauge bar measurement.**

5. The finished braking surface must be flat and parallel within 0.0007 inch; lateral runout must not exceed 0.003 inch on Custom Vehicles and 0.002 inch on Light Vehicles total indicator reading, and the surface finish of the braking area is to be 80/15 micro inches.

The ball and gauge bar kit is available through Rotunda Equipment (Part No. FRE-70160).

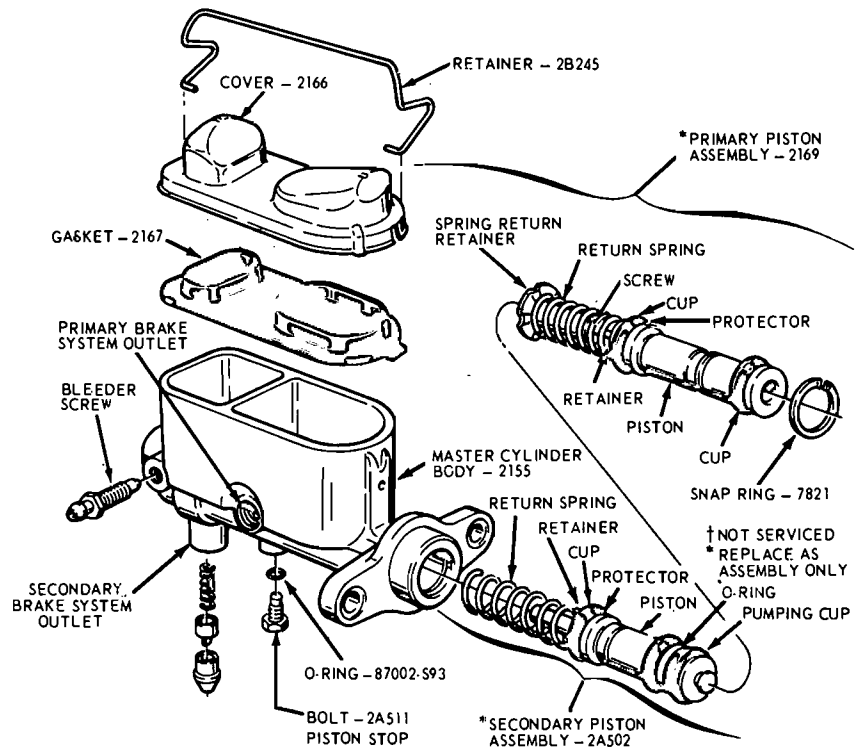

FIG. 17—Dual Master Cylinder Disassembled

the cylinder as a unit instead of overhauling the cylinder with a service repair kit.

**DISASSEMBLY**

1. Clean the outside of the master cylinder and remove the filler cover and diaphragm. Pour out any brake fluid that remains in the cylinder. Discard the old brake fluid.
2. Remove the secondary piston stop bolt from the bottom of the cylinder (Fig. 17).
3. Remove the bleed screw, if required.
4. Depress the primary piston and remove the snap ring from the retaining groove at the rear of the master cylinder bore (Fig. 18). Remove the push rod and the primary piston assembly from the master cylinder bore. Do not remove the screw that retains the primary return spring retainer, return spring, primary cup and protector on the primary piston. This assembly is factory pre-adjusted and should not be disassembled.
5. Remove the secondary piston assembly. Do not remove the outlet tube seats, outlet check valves and outlet check valve springs from the master cylinder body.

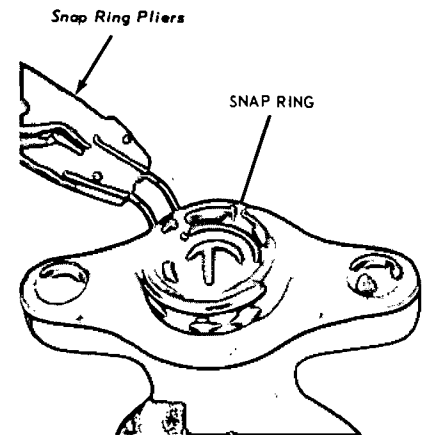

FIG. 18—Removing Snap Ring—Typical

**INSPECTION AND REPAIR**

1. Clean all parts in clean isopropyl alcohol, and inspect the parts for chipping, excessive wear or damage. When using a master cylinder repair kit, install all the parts supplied.
2. Check all recesses, openings and internal passages to be sure they are open and free of foreign matter. Use an air hose to blow out dirt and

**100% GUARANTEED**

**BUY IT NOW!**

**Click Here To Order**

PayPal, American Express, Discover, MasterCard, VISA

cleaning solvent. Place all parts on a clean pan or paper.

3. Inspect the master cylinder bore for signs of etching, pitting, scoring or rust. If it is necessary to hone the master cylinder bore to repair damage, do not exceed allowable hone specifications.

### ASSEMBLY

1. Dip all parts except the master cylinder body in clean Rotunda Extra Heavy Duty Brake Fluid.

2. Carefully insert the complete secondary piston and return spring assembly in the master cylinder bore.

3. Install the primary piston assembly in the master cylinder bore.

4. Depress the primary piston and install the snap ring in the cylinder bore groove.

5. Install the push rod, boot and retainer on the push rod, if so equipped. Install the push rod assembly into the primary piston. Make sure the retainer is properly seated and holding the push rod securely.

6. Position the inner end of the push rod boot (if so equipped) in the master cylinder body retaining groove.

7. Install the secondary piston stop bolt and O-ring in the bottom of the master cylinder.

8. Install the bleed screw (if so equipped). Install the gasket (diaphragm) in the master cylinder filler cover. Position the gasket as shown in Fig. 17. Make sure the gasket is securely seated.

9. Install the cover and gasket on the master cylinder and secure the cover into position with the retainer.

### DISC BRAKE CALIPER Disassembly

1. Remove the caliper assembly from the vehicle as outlined in Section 2.

2. Remove the caliper locating pins from the caliper assembly and lift the anchor plate from the caliper.

3. Slide the two outer shoe retaining clips off the retaining pins (Fig. 19).

4. Remove the two retaining pins, then remove the outer brake shoe from the caliper.

5. Slide the inner brake shoe out until it is free of the hold-down

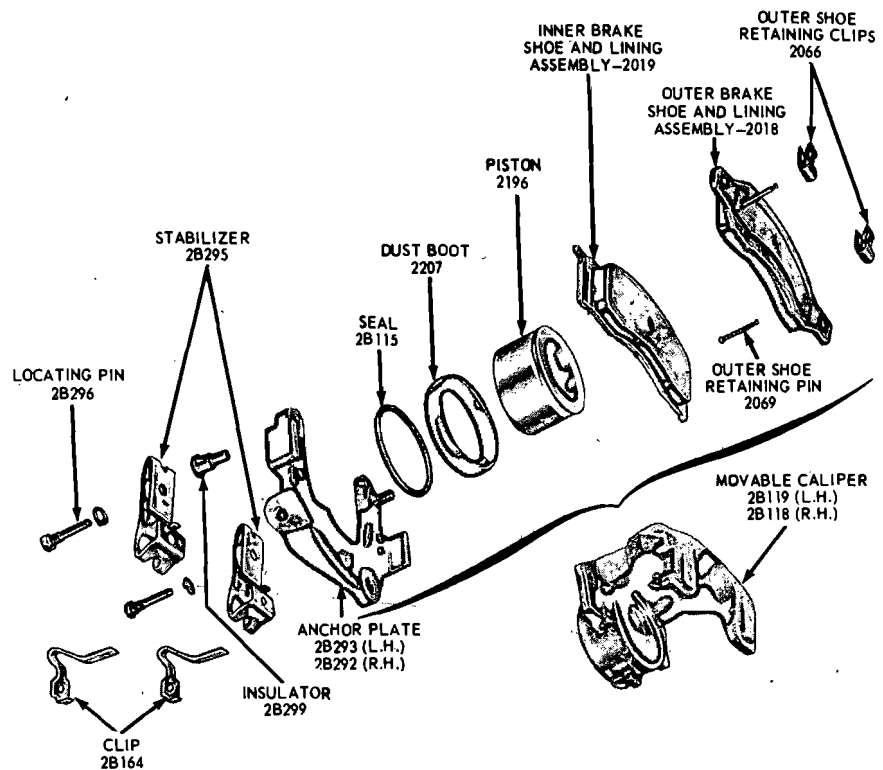

H 1573-C

FIG. 19—Caliper Assembly—Disassembled

ton. Place a cloth over the piston before applying air pressure to prevent damage to the piston. If the piston is seized and cannot be forced from the caliper, tap lightly around the piston while applying air pressure. Care should be taken because the piston can develop considerable force due to pressure build-up.

7. Remove the dust boot from the caliper assembly.

8. Remove the rubber piston seal from the cylinder and discard it.

### Cleaning and Inspection

Clean all metal parts with isopropyl alcohol or a suitable solvent. Use clean, dry, compressed air to clean out and dry the grooves and passage ways. Be sure that the caliper bore and component parts are completely free of any foreign material.

Check the cylinder bore and piston for damage or excessive wear. Replace the piston if it is pitted, scored, or the chrome plating is worn off.

### Assembly

1. Apply a film of clean brake fluid to the new caliper piston seal and install it in the cylinder bore. Be sure the seal does not become twisted

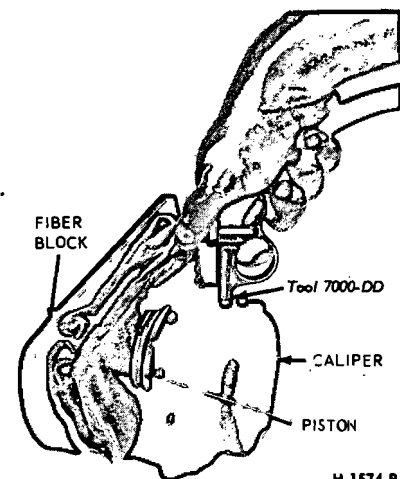

H 1574-B

FIG. 20—Removing Piston From Caliper

and that it is seated fully in the groove.

2. Install a new dust boot by setting the flange squarely in the outer groove of the caliper bore.

3. Coat the piston with the specified fluid and install the piston in the cylinder bore. Spread the dust boot over the piston as it is installed. Seat the dust boot in the piston groove.

4. Position the inner brake shoe so that the ears of the shoe rests on the

100% SATISFACTION GUARANTEED

**BUY IT NOW!**

Click Here To Order

PayPal American Express Discover Novus MasterCard VISA

top of the anchor plate bosses and beneath the hold-down springs.

5. Install new caliper locating pin insulators in the anchor plate.

6. Position the caliper on the an-

chor plate.

7. Apply water or isopropyl alcohol to the caliper locating pins and install them loosely in the anchor plate. **Be sure the guide pins are free**

**of oil, grease or dirt.**

8. Install the caliper on the spindle as outlined under Disc Brake Caliper Assembly.

## 4 SPECIFICATIONS

### BORE DIAMETERS MASTER CYLINDER

Models		Master Cylinder Bore Dia.
		With Power Brake <sup>Ⓞ</sup>
Ford, Mercury and Meteor	Taxi and Station Wagon	1.000
	Other	1.000
Montego and Fairlane	Pass. except Conv. 250, 302 CID Engines	0.9375
	Pass. and Conv. 351, 390, 428 CID Eng.	0.9375
	Convertible 250, 302 CID Engines	0.9375
	Station and Ranchero	0.9375
Falcon	9 Inch Brake Passenger Car	N/A
	10 Inch Brake Station Wagon	N/A
	10 Inch Brake Passenger Car	N/A
Mustang and Cougar	200 CID Engine	1.000
	351, 390, 428 CID Engine	1.000
	250, 302, CID Engine	1.000
Thunderbird		1.000
Continental Mark III		1.000
Lincoln Continental		1.000
<sup>Ⓞ</sup> Max.-Allowable Hone 0.003 <sup>Ⓞ</sup> 2.755 for Ford, Mercury, Meteor with Disc Brakes 2.381 for Fairlane, Montego, Mustang, Cougar with Disc Brakes		

CH1724-A

**100% SATISFACTION GUARANTEED**

**BUY IT NOW!**

**Click Here To Order**

PayPal American Express Discover MasterCard VISA

**SHOE AND LINING DIMENSIONS--  
DISC BRAKES – INCHES**

	Ford, Mercury, Meteor, Thunderbird, Continental Mark III, Lincoln Continental	Fairlane, Montego Mustang, Cougar
Lining Material	Bonded	Bonded
Lining Size	7.38 x 2.27 Outer 5.36 x 2.03 Inner	6.82 x 1.80 Outer 4.90 x 1.84 Inner
Lining Area - Square Inches per Segment	12.25 Outer 8.44 Inner	11.30 Outer 8.80 Inner
Lining Thickness Nominal	0.394	0.333 Outer 0.362 Inner
Lining Wear Limit (Front Surface of Shoe) Max.	0.030	0.030
Lining Taper – Max.	0.125	0.125
Lining to Rotor Clearance (Brakes Released)	0.000-0.010	0.000-0.010

CH1725-A

**TORQUE LIMITS – HUB TO SPINDLE**

Description	Ft-Lbs
Hub and Drum or Rotor Assembly to Front Wheel Spindle	Rotate hub while torquing to 17-25 ft-lbs. Back off the adjusting nut 1/2 turn and retighten to 10-15 inch pounds while rotating wheel. Selectively position nut retainer on adjusting nut so that a set of slots are in line with cotter pin hole. Adjusting nut should not be rotated in this operation. Lock adjusting nut and nut retainer with cotter pin so that the cotter pin end does not interfere with seating of wheel static collector in spindle hole.

CH1725-A

**CALIPER CYLINDER BORE DIAMETER – INCHES**

Ford, Mercury, Meteor, Thunderbird, Continental Mark III Lincoln Continental	2.755
Mustang, Cougar, Fairlane and Montego	2.381

CH1725-A

**ROTOR DIMENSIONS**

Car Line	Nom. Thickness	Diameter	
		Outside	Inside
Ford, Mercury, Meteor, Lincoln Continental	1.180	11.72	7.785
Thunderbird, Continental Mark III	1.180	11.72	7.785
Fairlane, Montego, Mustang and Cougar	0.935	11.29	7.355

CH1725-A

**ROTOR REFINISH**

The following requirements must be met when resurfacing disc brake rotors:

Rotunda Disc Brake Attachment FRE-2249-2 is the only approved tool to be used to refinish the disc brake rotors. The step-by-step resurfacing procedure provided with the tool must be adhered to.

The finished braking surfaces of the rotor must be flat and parallel within 0.0007 inch; lateral runout must not exceed 0.003

on Custom vehicles and 0.002 inch on light vehicles total indicator reading, and the surface finish of the braking surfaces are to be 80-15 micro inches.

On all models the limiting dimension from the inner bearing cup to the inner rotor face must be measured with a ball and gage bar (Rotunda FRE-70160).

CH1726-A

**100% SATISFACTION GUARANTEED**

**BUY IT NOW!**

**Click Here To Order**

PayPal American Express Discover MasterCard VISA

**TORQUE LIMITS-GENERAL-FT-LBS.**

	Ford-Mercury Meteor	Fairlane- Montego	Mustang- Cougar	Thunderbird Continental Mark III	Lincoln Continental
Master Cylinder to Booster	13-25	13-25	13-25	13-25	13-25
Booster to Dash Panel	13-25	13-25	13-25	13-25	13-25
Disc Brake Caliper to Spindle Bolts	Upper <sup>Ⓞ</sup> 110-140	Upper <sup>Ⓞ</sup> 100-140	Upper <sup>Ⓞ</sup> 110-140	Upper <sup>Ⓞ</sup> 110-140	100-150
	Lower 90-120	Lower 55-75	Lower 55-75	Lower 90-120	90-120
Disc Brake Rotor Splash Shield to Spindle	9-14	9-14	9-14	9-14	9-14
Brake Hose to Caliper Connection Bolt	27-32	27-32	27-32	27-32	27-32
Caliper Locating Pins	25-35	25-35	25-35	25-35	25-35
Caliper Stabilizer to Anchor Plate Bolt	8-11	8-11	8-11	8-11	8-11
Caliper Brake Shoe Clips	6-10	6-10	6-10	6-10	7-9
Caliper Bleeder Screws	6-15	6-15	6-15	6-15	6-15
Wheel Cylinder Bleeder Screw	6-15	32-65 <sup>Ⓞ</sup> Inch-lb.	32-65 <sup>Ⓞ</sup> Inch-lb.	6-15	6-15
Pressure Differential Valve Bracket Bolts and Nuts	7-11	7-11	7-11	7-11	7-11
Brake Hose Connection to Front Wheel Cylinder	12-20	12-20	12-20		
Hydraulic Tube Connections	3/8 x 24	10-15	10-15	10-15	10-15
	7/16 x 24	10-15	10-15	10-15	10-15
	1/2 x 20	10-17	10-17	10-17	10-17
	9/16 x 18	10-17	10-17	10-17	10-17
Hub and Rotor Nuts	70-115	4 lug 55-85	4 lug 55-85	70-115	70-115
		5 lug 70-115	5 lug 70-115		

The upper bolt must be tightened first.  
 On front disc brake calipers 6-15 ft-lbs.  
 All hydraulic lines must be tightened to the specified torque value and be free of fluid leakage.

CH1727-A

**100% SATISFACTION GUARANTEED**

**BUY IT NOW!**

**Click Here To Order**

PayPal American Express Discover MasterCard VISA

**SPECIAL TOOLS**

Ford Tool No.	Former No.	Description
	2162	Adapter Cap
Tool 7000-00		Rubber Tipped Air Nozzle
Rotunda 70160		Ball and Gage Bar
Tool 33621	33621	Internal Snap Ring Pliers
	Milbar 1112-144	Inch Pound Torque Wrench
	J 22742 (Kent Moore)	Bleeder Valve Clip Spring
Rotunda FRE 22492		Disc Brake Rotor Attachment

CH1728-A



**BUY IT NOW!**  
Click Here To Order 



# PART 12-04 Parking Brake

COMPONENT INDEX Applies To Models As Indicated	All Models	Ford	Mercury	Meteor	Cougar	Fairlane	Falcon	Maverick	Montego	Mustang	Lincoln-Continental	Thunderbird	Continental-Mark III
PARKING BRAKE	04-01												
Description	04-01												
PARKING BRAKE ACTUATOR TO CONTROL CABLE		04-09	04-09	04-09	N/A	N/A	N/A	N/A	N/A	N/A	N/A	04-09	04-09
Removal and Installation		04-09	04-09	04-09	N/A	N/A	N/A	N/A	N/A	N/A	N/A	04-09	04-09
PARKING BRAKE ACTUATOR TO EQUALIZER CABLE		04-12	04-12	04-12	N/A	N/A	N/A	N/A	N/A	N/A	N/A	04-12	04-12
Removal and Installation		04-12	04-12	04-12	N/A	N/A	N/A	N/A	N/A	N/A	N/A	04-12	04-12
PARKING BRAKE CONTROL		04-03	04-03	04-03	04-03	04-03	04-03	04-03	04-03	04-03	04-09	04-09	04-09
Removal and Installation		04-03	04-03	04-03	04-03	04-03	04-03	04-03	04-03	04-03	04-09	04-09	04-09
PARKING BRAKE EQUALIZER TO CONTROL CABLE		N/A	N/A	N/A	04-11	04-11	04-11	04-11	04-11	04-11	04-11	N/A	N/A
Removal and Installation		N/A	N/A	N/A	04-11	04-11	04-11	04-11	04-11	04-11	04-11	N/A	N/A
PARKING BRAKE EQUALIZER TO REAR WHEEL CABLE		04-12	04-12	04-12	04-13	04-13	04-13	04-12	04-13	04-13	04-13	04-12	04-12
Removal and Installation		04-12	04-12	04-12	04-13	04-13	04-13	04-12	04-13	04-13	04-13	04-12	04-12
PARKING BRAKE LINKAGE	04-02												
Adjustment	04-02												

A page number indicates that the item is for the vehicle(s) listed at the head of the column.  
N/A indicates that the item is not applicable to the vehicle(s) listed.

## 1 DESCRIPTION

An independent foot-operated (hand-operated on Maverick) parking brake control actuates the rear wheel brake shoes through a cable linkage. On all models except Ford, Mercury, Meteor, Thunderbird, Continental Mark III and Lincoln Continental. The operating cable is routed from the parking brake control assembly to the equalizer. On Ford, Mercury, Meteor, Thunderbird, Continental Mark III and Lincoln Continental the operating cable is routed from the parking brake control assembly to the actuator assembly. On Maverick, the

to the equalizer except on the Lincoln Continental. The rear brake cables connect the equalizer assembly to the parking brake lever at each rear secondary shoe. Refer to Part 12-02.

On all vehicles except Maverick, there are two types of foot-operated parking brake controls used. The automatic (vacuum) release type (Fig. 1) is used on the Mercury, Ford LTD, Meteor LeMoyné, Thunderbird, Continental Mark III and Lincoln Continental models. All other models use the manual release-type (Fig. 2).

On the automatic-type, the vacuum power unit with mounting bracket is riveted to the control assembly. The vacuum actuated piston within the unit is connected by a rod to the upper end of the release lever (Fig. 9).

The lower end of the release lever extends out for alternate manual release in the event of vacuum power failure or for optional manual release at any time.

Hoses connect the power unit and the engine manifold to a vacuum release valve on the back-up light switch.

On a Maverick, the parking brake control is hand-operated. When the handle is pulled the primary and secondary brake shoes are forced against the rear brake drums. The handle is held in the applied position by the engagement of a spring loaded pawl with a ratchet. Turning the handle counterclockwise disengages the pawl from the ratchet to release the brakes.



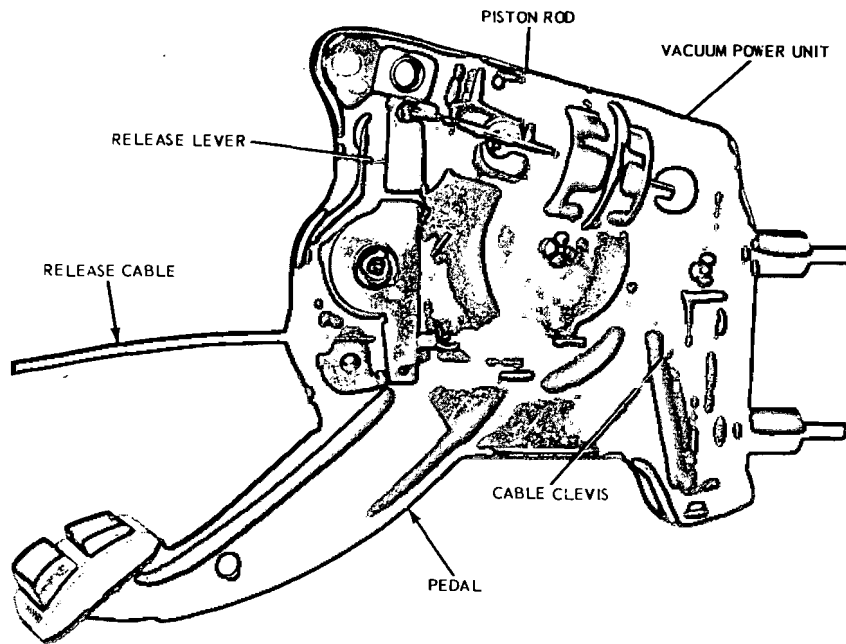

H 1635-A

FIG. 1—Parking Brake Control Assembly with Automatic Release—Typical

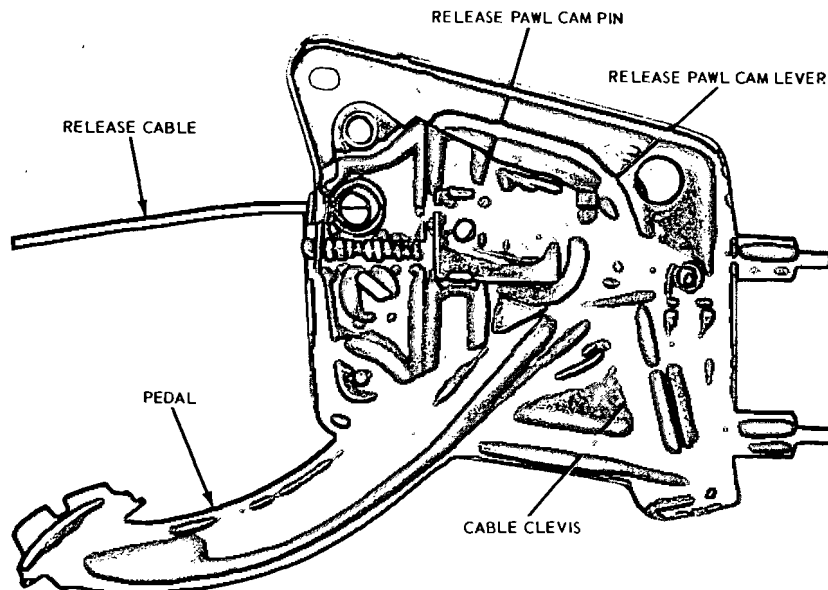

H 1636-A

FIG. 2—Parking Brake Control Assembly with Manual Release—Typical

## 2 IN-VEHICLE ADJUSTMENTS AND REPAIRS

**100% SATISFACTION GUARANTEED**

**BUY IT NOW!**

**Click Here To Order**

PayPal | American Express | Discover | MasterCard | VISA

2. Place the transmission in neutral. Raise the vehicle.

3. Tighten the adjusting nut against the cable equalizer (Fig. 3, 4, 5, 6, 7, 8) to cause rear wheel brake drag.

Then, loosen the adjusting nut until the rear brakes are fully released. There should be no brake drag.

4. Lower the vehicle and check the operation of the parking brake.

### 3 REMOVAL AND INSTALLATION

#### PARKING BRAKE CONTROL ASSEMBLY

##### FORD, MERCURY AND METEOR

###### Removal

Refer to Fig. 3.

1. Make sure the parking brake is fully released.
2. Remove all tension from the rear cables by backing off the adjusting nut from the equalizer.
3. Remove the roll pin that secures the release knob to the cable and remove the knob.
4. Remove the nut that secures the release cable to the instrument panel and remove the cable from the rear of the instrument panel.
5. Remove the two nuts attaching the control assembly to the dash panel.
6. Remove the cap screw attaching the control assembly to the cowl side bracket.
7. Disconnect the hose to the parking brake vacuum unit, if so equipped.
8. Remove the front cable assembly retainer clip from the cable assembly and disconnect the cable ball from the control clevis.
9. Remove the control assembly from the vehicle.

###### Installation

1. Position the control assembly in the vehicle.
2. Fit the cable assembly through its mounting hole and install the retaining clip. Connect the cable ball to the control clevis.
3. Connect the vacuum hose to the parking brake unit, if so equipped.
4. Install the attaching cap screw to the cowl side bracket. Do not tighten.
5. Install the two control assembly-to-dash panel nuts. Tighten the nuts and the cap screw to specifications.
6. Insert the release cable into the instrument panel and install the retaining nut.
7. Install the release knob on the

#### FAIRLANE, MONTEGO AND FALCON

###### Removal

Refer to Fig. 4.

1. Make sure the parking brake is completely released.
2. Remove all tension from the rear cables by backing off the jam nut and adjusting nut from the equalizer.
3. Working inside the vehicle, remove the four bolts and one nut retaining the left air vent and cable assembly to the dash and instrument panels. Remove the vent assembly.
4. Remove the parking brake front cable ball retaining clip from the clevis.
5. Disconnect the cable ball from the notch in the brake clevis.
6. Remove the three screws that attach the control assembly to the left cowl inner side panel.
7. Disconnect the wire lead at the parking brake warning light switch and remove the control assembly.

###### Installation

1. Connect the wire lead to the parking brake warning light switch.
2. Position the control assembly to the cowl inner side panel and install the three attaching screws.
3. Connect the ball-end of the parking brake front cable assembly to the control assembly, and install the hairpin retainer.
4. Position the cable ball in the notch in the brake clevis.
5. Position the left air vent assembly to the dash and instrument panels. Install the four bolts and one nut retaining the air vent to the panels.
6. Check the operation of the parking brake. Adjust the parking brake.

#### MUSTANG AND COUGAR

###### Removal

Refer to Fig. 5.

1. Make sure the parking brake is completely released.
2. Remove all tension from the rear cables by backing off the jam nut and adjusting nut from the equalizer.
3. Disconnect the wire lead at the parking brake warning light switch (if so equipped).
4. Remove the parking brake front cable ball retaining clip from the clevis.

5. Remove the parking brake warning light switch and attaching screw (if so equipped).

6. Disconnect the cable ball from the notch in the brake clevis.

7. Remove the three screws that attach the control assembly to the left cowl inner side panel.

8. Pull the control away from the cowl panel. Remove the hair-pin retainer securing the front cable assembly to the control assembly. Remove the control assembly.

###### Installation

1. Connect the ball-end of the parking brake front cable assembly to the control assembly, and install the hair-pin retainer.

2. Position the control assembly to the cowl inner side panel and install the three attaching screws.

3. Position the parking brake warning light switch and install the attaching screw. Connect the parking brake warning light switch wire lead (if vehicle is so equipped).

4. Position the cable ball in the notch in the brake clevis.

5. Check the operation of the parking brake. Adjust the parking brake.

#### MAVERICK

###### Removal

Refer to Fig. 6.

1. Remove the two screws that hold the control bracket on the instrument panel.

2. Remove the two nuts that secure the control to the dash panel.

3. Remove the hairpin clip and clevis pin that secures the pulley to the control handle assembly.

4. Disengage the locking pawl. Slide the rod forward and remove the ball on the cable from the slot on the control assembly.

5. Remove the control from the vehicle.

###### Installation

Refer to Fig. 6.

1. Disengage the locking pawl. Slide the rod forward and connect the ball end of the cable to the slot in the control assembly and pull the rod rearward, engaging the pawl in the ratchet.

**SATISFACTION 100% GUARANTEED**

**BUY IT NOW!**

**Click Here To Order**

PayPal American Express Discover MasterCard VISA

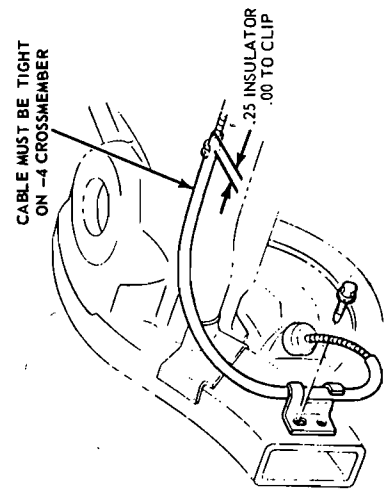

VIEW X

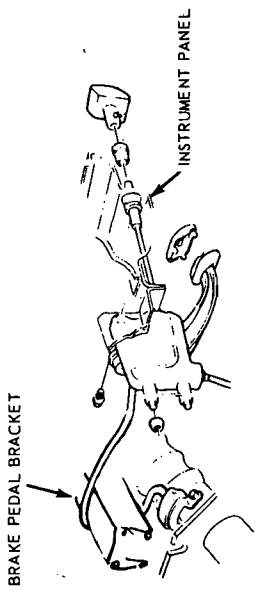
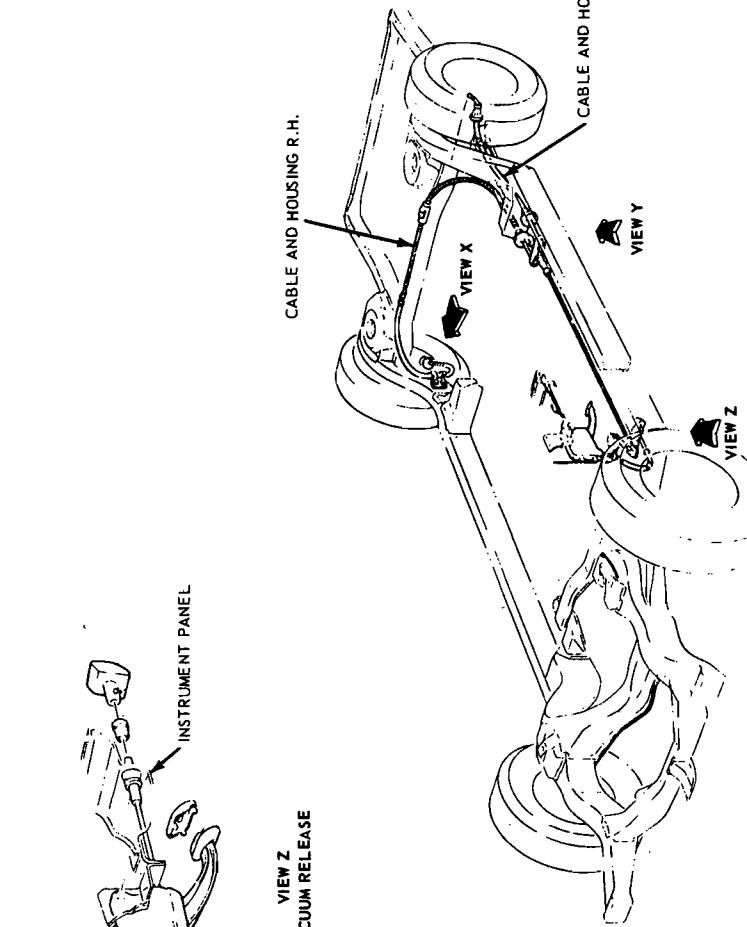

VIEW Z  
VACUUM RELEASE

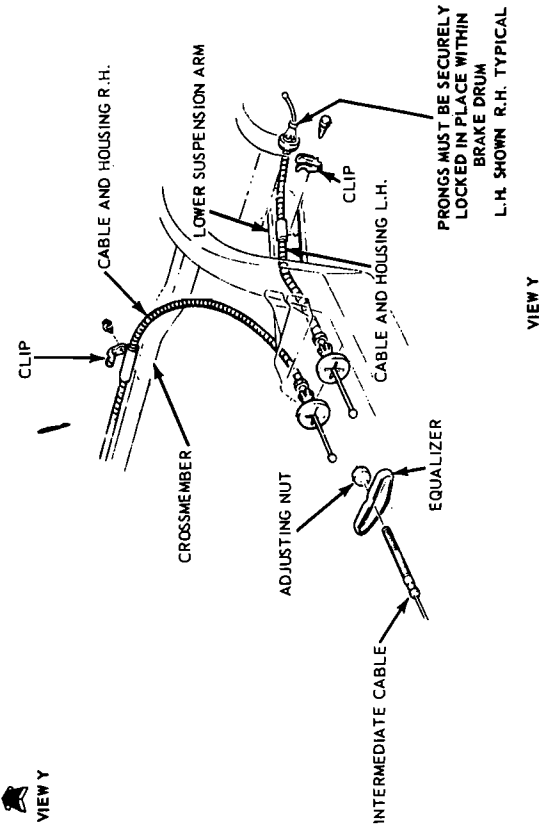
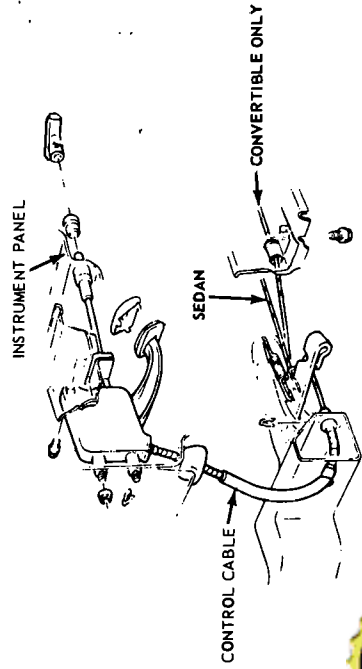

VIEW Y

PRONGS MUST BE SECURELY LOCKED IN PLACE WITHIN BRAKE DRUM L.H. SHOWN R.H. TYPICAL

H1645-A

**BUY IT NOW!**

Click Here To Order

100% GUARANTEED

PayPal

MasterCard

VISA

rd, Mercury and Meteor

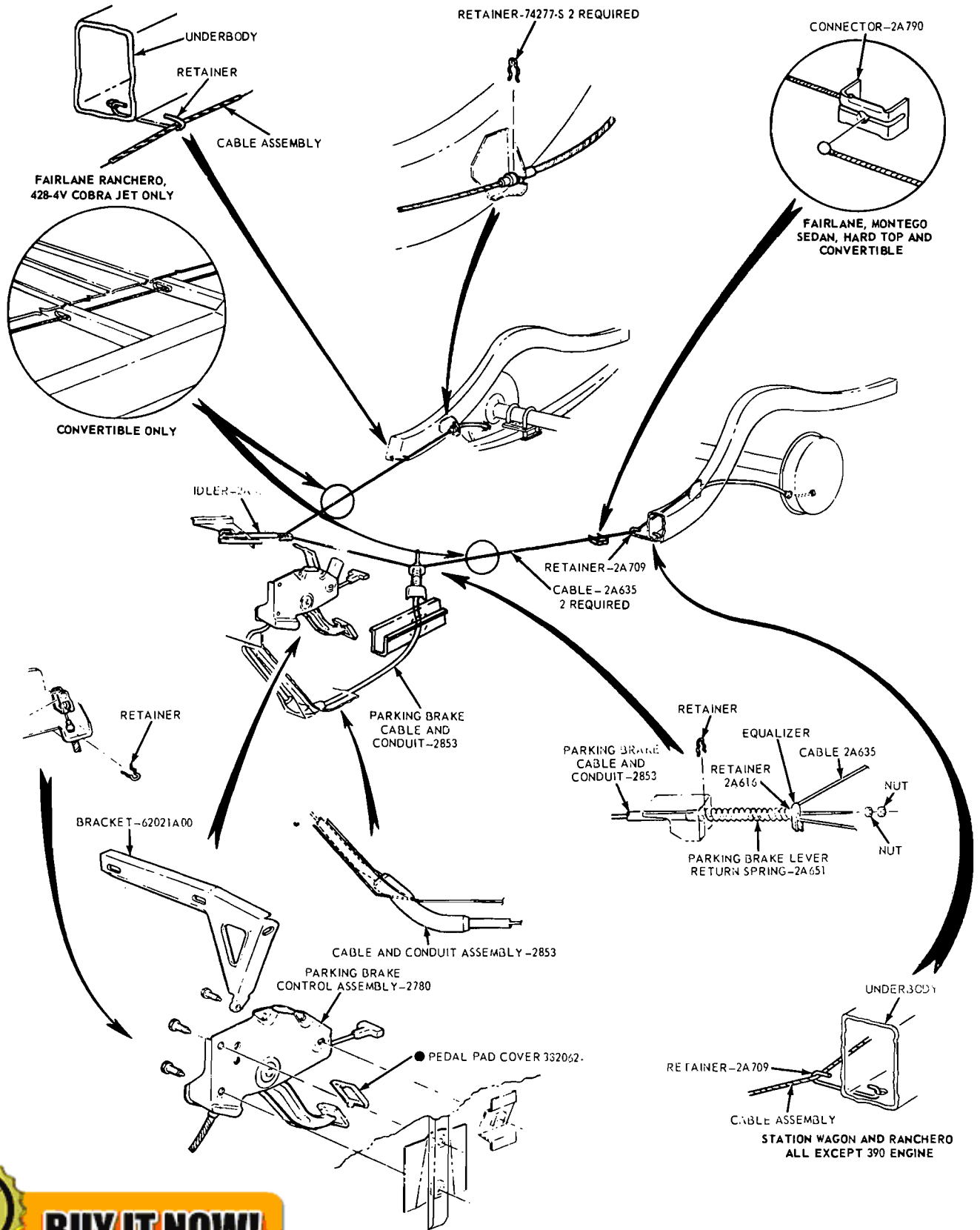

**BUY IT NOW!**

**Click Here To Order**

Fairlane, Montego and Falcon



H1646-A

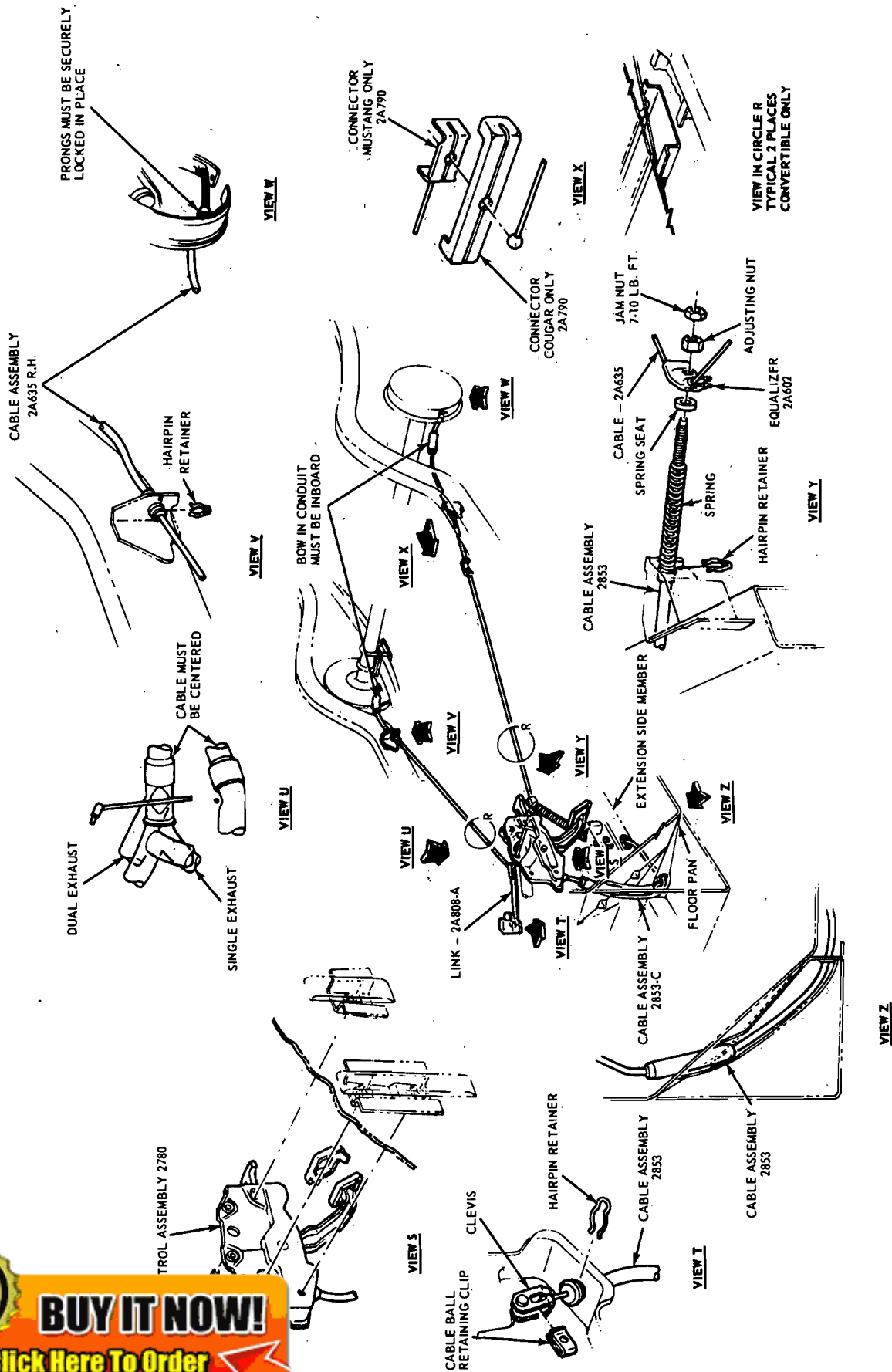

FIG. 5—Parking Brake System—Mustang and Cougar

**100% SATISFACTION GUARANTEED**

**BUY IT NOW!**

**Click Here To Order**

PayPal, American Express, Discover, MasterCard, VISA

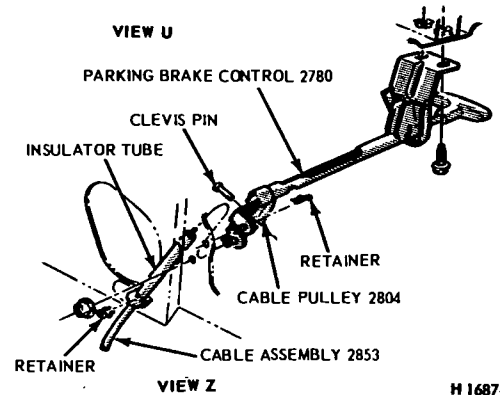
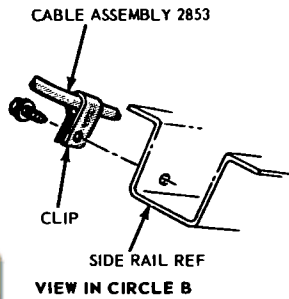
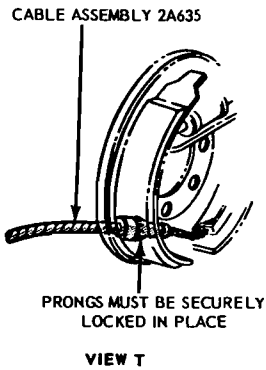
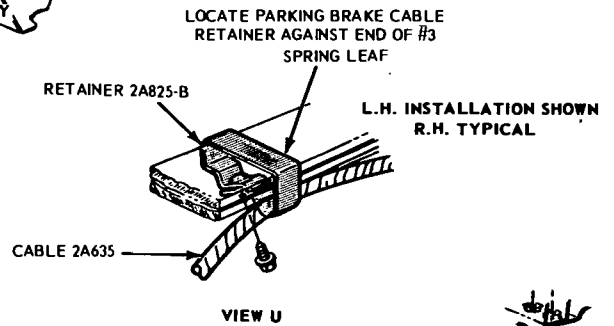
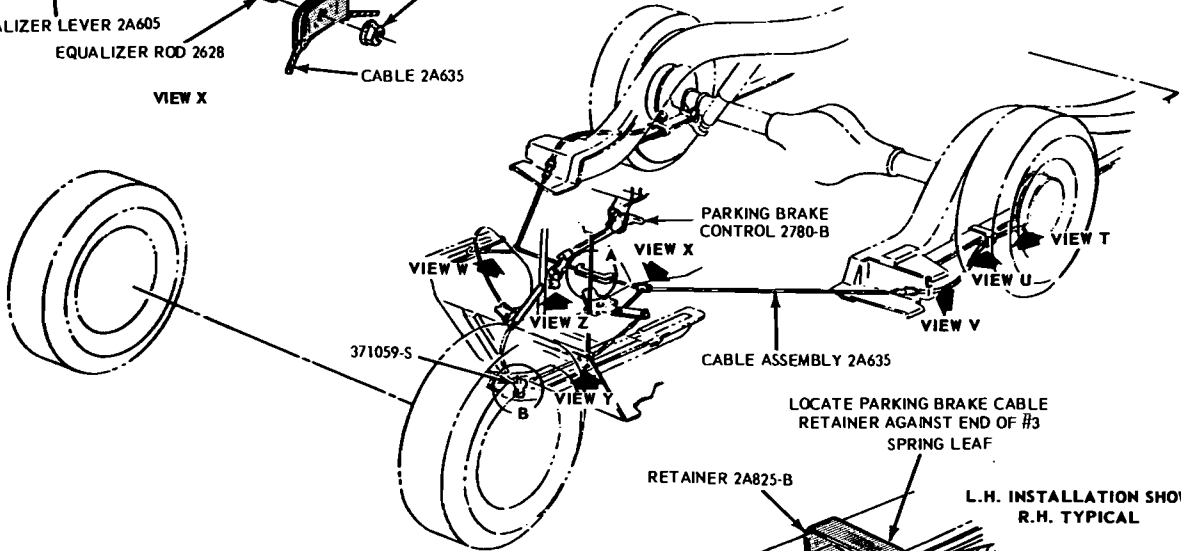
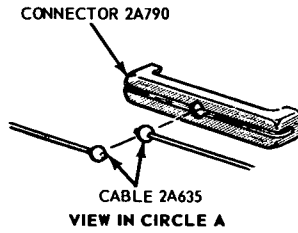
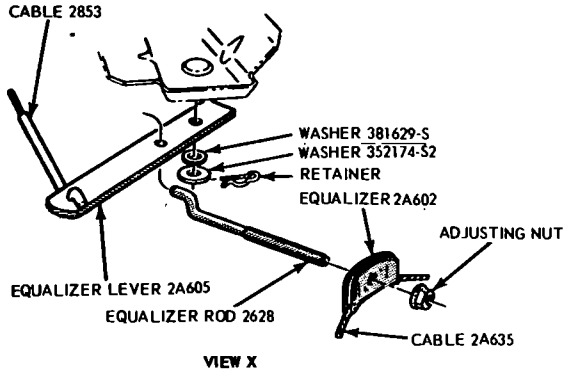
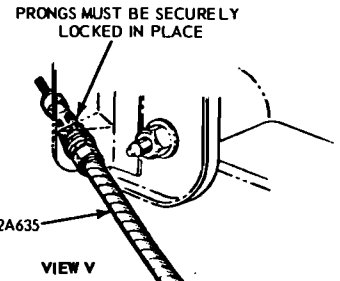
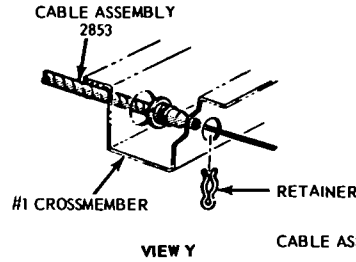
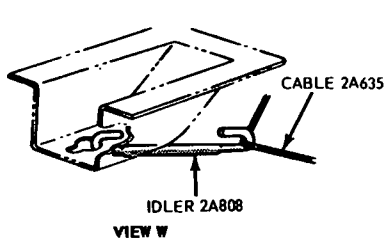

**100% SATISFACTION GUARANTEED**

**BUY IT NOW!**

**Click Here To Order**

System



2. Assemble the pulley to the control handle and the clevis pin. Install the clevis retainer.

3. Position the assembly against the dash panel and instrument panel. Secure the assembly to the instrument panel with the two screws.

4. Working under the hood, install the two parking brake control-to-dash panel attaching nuts.

5. Check the parking brake for proper operation. Adjust the parking brake.

### THUNDERBIRD AND CONTINENTAL MARK III

#### Removal

Refer to Fig. 7.

1. Remove the two nuts retaining the control to the dash panel.

2. Remove two screws from the left scuff plate.

3. Remove one screw retaining the left cowl trim panel and remove the panel.

4. Remove the two screws retaining the left air duct and remove the air duct.

5. Remove the two screws retaining the dimmer switch and position the switch out of the way.

6. Remove the clip retaining the cable assembly to the control.

7. Disconnect the cable ball from the control clevis.

8. Disconnect the vacuum hose at the brake release.

9. Remove the bolt retaining the control to the cowl side bracket and remove the control.

#### Installation

1. Position the parking brake control in the vehicle.

2. Install the cable assembly in the control and connect the cable ball to the control clevis.

3. Install the clip retaining the cable to the control.

4. Install the bolt retaining the control to the cowl side bracket.

5. Connect the vacuum hose to the parking brake release vacuum motor.

6. Position the dimmer switch and install the retaining screws.

7. Position the air duct and install the retaining screws.

8. Position the cowl trim panel and install the retaining screw.

### LINCOLN CONTINENTAL

#### Removal

Refer to Fig. 8.

1. Make sure that the parking brake is fully released.

2. Remove the two nuts from the control assembly mounting studs on the engine compartment side of the dash panel.

3. Working under the instrument panel, remove the control assembly to mounting bracket retaining screw.

4. Disconnect the vacuum tube from the automatic release vacuum servo motor.

5. Remove the retaining clip from the cable housing at the control assembly.

6. Disconnect the control cable ball end from the control assembly cable clevis.

7. Remove the control assembly from the vehicle.

#### Installation

1. Connect the vacuum tube to the automatic release vacuum servo motor.

2. Install the control assembly mounting studs through the holes in the dash panel and against the body mounting bracket.

3. Assemble the control cable ball end to the control assembly cable clevis.

4. Install the cable retaining clip at the control assembly.

5. Install the control assembly-to-mounting bracket retaining bolt and torque them to specifications. Torque them to 12-25 ft-lbs.

6. Install the nuts on the control assembly mounting studs on the engine side of the dash panel and torque them to 10-20 ft-lbs.

7. Verify correct operation of the parking brake system.

### PARKING BRAKE ACTUATOR—TO CONTROL CABLE

#### FORD, MERCURY AND METEOR

#### Removal

1. Raise the vehicle on a hoist.

2. Loosen the actuator lever to equalizer cable adjusting nut at the equalizer (Fig. 3).

3. Disconnect the cable ball from the clevis on the actuator lever.

4. Remove spring clip that retains

the cable to the frame.

5. From inside of passenger compartment, remove spring clip that retains the cable to the parking brake control. Disconnect the cable ball from the control assembly.

6. Remove the cable assembly from the vehicle.

#### Installation

1. Position the cable through the provided openings and in the approximate final installation position.

2. Install the hairpin retainer on the cable at the frame crossmember.

3. Connect the ball end of the cable to the parking brake control. Install the cable-to-control hairpin retaining clip.

4. Position the cable seal at the dash panel, and slide the retaining clip upward to seal the cable at the dash opening.

5. Connect the ball end of the cable to the clevis on the actuator lever.

6. Adjust the parking brake.

7. Lower vehicle on hoist.

### THUNDERBIRD AND CONTINENTAL MARK III

#### Removal

Refer to Fig. 7.

1. Partially raise the vehicle.

2. Back off the adjusting nut at the equalizer to relieve the tension on the cable.

3. Remove the spring at the actuator lever and disconnect the control cable from the clevis on the lever.

4. Remove the clip retaining the control cable assembly to the frame bracket.

5. Attach a length of wire to the control cable.

6. Working inside the vehicle remove two screws retaining the left scuff plate.

7. Remove one screw and remove the left cowl side trim panel.

8. Remove the two screws retaining the left air duct to the inner panel and remove the air duct.

9. Remove the two screws retaining the dimmer switch and position the dimmer switch back out of the way.

10. Remove the clip retaining the cable assembly to the control and remove the cable ball from the control clevis.

11. Pull the cable up through the opening in the dash panel and remove the cable from the length of wire.

**SATISFACTION 100% GUARANTEED**

**BUY IT NOW!**

**Click Here To Order**

PayPal American Express Discover MasterCard VISA



### Installation

1. Attach the cable to the length of wire and pull the cable down through the opening in the dash panel.
2. Position the upper end of the control cable to the control. Connect the cable ball to the control clevis and install the clip retaining the cable housing to the control.
3. Remove the length of wire from the cable assembly and position the cable in the frame bracket. Install the retainer.
4. Connect the cable ball to the clevis on the actuator lever and install the actuator lever spring.
5. Adjust the parking brake.
6. Reposition the dimmer switch and install the retaining screws.
7. Position the air duct to the inner panel and install the retaining screws.
8. Position the cowl side trim panel and install the retaining screw.
9. Install the two screws in the scuff plate.

### PARKING BRAKE EQUALIZER TO CONTROL CABLE

#### FAIRLANE, MONTEGO AND FALCON

### Removal

Refer to Fig. 4.

1. Make certain the parking brake is fully released.
2. Raise the vehicle on a hoist. Remove the two nuts that attach the cable to the equalizer. Remove the equalizer, spring seat and spring.
3. Remove the hairpin retainer holding the cable assembly to the body bracket and remove the cable from the slot in the bracket.
4. Lower the vehicle partially.
5. Remove the hairpin retainer which retains the cable assembly to the control.
6. Remove the cable bolt retaining clip from the control clevis and disconnect the cable ball from the clevis.
7. Pull the cable down through the opening in the floor pan and frame side rail.

### Installation

1. Route the new cable through the side rail and up through the

control and install the hairpin retainer.

4. Raise the vehicle.
5. Position the cable in the body bracket and install the hairpin retainer.
6. Position the spring, spring retainer and equalizer on the cable and install the two nuts.
7. Adjust the parking brake.

### MAVERICK

### Removal

Refer to Fig. 6.

1. Remove the hairpin clip and clevis pin that secures the cable pulley to the control handle assembly and remove the pulley.
2. Disengage the locking pawl and slide the control rod forward. Remove the cable ball from the slot in the control rod.
3. Remove the hairpin retainer from the dash panel bracket and disengage the cable from the bracket.
4. Pull the cable and insulator tube down through the hole in the dash panel. Remove the insulator tube from the cable.
5. Raise the vehicle on a hoist.
6. Remove the retaining screw and clip from the cable on the chassis side rail.
7. Disengage the cable stepped-rod from the equalizer lever.
8. Remove the hairpin retainer from the cable housing at the crossmember.
9. Pull the cable forward through the crossmember and remove the cable from the vehicle.

### Installation

Refer to Fig. 6.

1. Pass the stepped-rod rearward through the crossmember and connect it into the equalizer lever.
2. Install the hairpin retainer on the cable housing at the crossmember.
3. Install the cable housing retaining clip on the cable and install the retaining screw on the chassis side rail.
4. Install the insulator tube onto the upper end of the cable and push the cable and insulator up through the hole in the dash panel.
5. Engage the upper end of the cable housing in the dash panel bracket and install the hairpin retainer.
6. Connect the cable ball to the control rod.
7. Assemble the pulley to the con-

trol assembly and install the clevis pin and hairpin retainer.

8. Check the parking brake for proper operation. Adjust the parking brake.

### MUSTANG AND COUGAR

### Removal

Refer to Fig. 5.

1. Make certain the parking brake is fully released.
2. Raise the vehicle on a hoist. Remove the two nuts that attach the cable to the equalizer. Remove the equalizer spring seat and spring.
3. Remove the hairpin retainer holding the cable assembly to the body bracket and pull the cable out of the side rail access holes.
4. Attach a wire to the end of the cable to assist in routing new cable.
5. Lower the vehicle.
6. Remove the parking brake front cable ball retaining clip from the clevis.
7. Disconnect the cable ball from the notch in the brake clevis.
8. Remove the hairpin retainer and remove the cable assembly from the brake control assembly.
9. Pull the cable assembly up through the opening in the floor and remove the wire from the end of the cable.

### Installation

Refer to Fig. 5.

1. Connect the wire to the end of the cable assembly and pull the cable down through the opening in the floor. Remove the wire.
2. Connect the cable assembly to the brake control assembly and install the hairpin retainer.
3. Position the ball end of the cable in the notch of the brake clevis.
4. Raise the vehicle on a hoist.
5. Pull the cable grommet into position and route the cable through the access holes in the side rail and under the fuel line.
6. Insert the cable into the body bracket and install the hairpin retainer.
7. Position the spring, spring seat, and equalizer on the cable and install the two nuts.
8. Adjust the parking brake.

### LINCOLN CONTINENTAL

### Removal

Refer to Fig. 8.



1. Make sure that the parking brake is fully released.
2. Raise the vehicle.
3. Loosen the parking brake cable adjusting nut at the equalizer lever.
4. Lower the vehicle.
5. Remove the cable housing retaining clip and then disconnect the control cable ball end from the control assembly clevis.
6. Raise the vehicle.
7. Pull the cable and housing downward through the dash panel opening.
8. Remove the retainer clip from the cable housing at the number 3 crossmember.
9. Disconnect the cable ball end from the parking brake cable clevis at the actuator lever.
10. Pull the parking brake cable forward through the holes in the number 3 crossmember and remove the cable and housing assembly from the vehicle.

#### Installation

1. Push the rear end of the parking brake cable rearward through the holes in the number 3 crossmember.
2. Connect the cable ball end to the parking brake cable clevis at the actuator lever.
3. Install the retaining clip on the cable housing at the number 3 crossmember.
4. Push the forward end of the cable and housing upward through the dash panel opening.
5. Lower the vehicle.
6. Connect the cable ball end to the control assembly clevis and install the retaining clip.
7. Raise the vehicle.
8. Adjust the parking brake. Refer to the Parking Brake Adjustment Procedures in this manual.
9. Lower the vehicle.
10. Verify correct operation of the parking brake.

#### PARKING BRAKE ACTUATOR-TO-EQUALIZER CABLE

FORD, MERCURY,  
METEOR, THUNDERBIRD  
AND CONTINENTAL  
MARK III

equalizer.

3. Remove the cable end from the equalizer.
4. Unhook the cable from the actuator, and remove from the vehicle.

#### Installation

1. Insert new cable end into actuator.
2. Insert cable end into equalizer and tighten the adjusting nut snug. Install the lock nut.
3. Adjust the parking brake.
4. Lower the vehicle.

#### PARKING BRAKE EQUALIZER TO REAR WHEEL CABLE

FORD, MERCURY,  
METEOR, THUNDERBIRD  
AND CONTINENTAL  
MARK III

#### Removal

1. Raise the vehicle and loosen the parking brake equalizer rod adjusting nut. Disconnect the equalizer from the rear cables (Figs. 3 and 7).
2. Compress the prongs on the left cable-to-frame side member retainer so the prong can pass through the side-member. Remove the clip that attaches the left cable to the left lower arm. Pull the cable thru the frame left side member.
3. Compress the prongs on the right cable-to-frame side member retainer bracket so the prong can pass through the bracket. Remove the clips retaining the right cable to the frame crossmember.
4. Remove the rear wheel cover and wheel. Remove the three Tinnerman nuts that hold the brake drum in place and remove the drum.
5. Working on the wheel side of the rear brake, remove the automatic brake adjuster spring. Compress the prongs on the parking brake cable retainer so that they can pass through the hole in the brake backing plate. Draw the cable retainer through the hole.
6. With the spring tension off the parking brake lever, lift the cable out of the slot in the lever, and remove the cable through the backing plate hole.

#### Installation

1. Pull enough of the parking brake cable through the housing so that the end of the cable may be inserted over the slot in the parking brake lever on the rear brake shoe.

2. Pull the excess slack from the cable, and insert the cable housing into the brake backing plate access hole so that the retainer prongs expand. **The prongs must be securely locked in place.** Install the automatic brake adjuster spring.

3. Position the right hand cable and the two retaining clips and screws on the rear crossmember. Compress the prongs on the right cable and position the cable in the retaining bracket on the frame side member. Be sure the locating stripe on the cable is midway between the retaining clips and tighten all retaining clip screws.

4. Position the left cable, retaining clip and screw on the left lower suspension arm. Compress the prongs on the left cable and position the cable through the frame side-member. The prongs must be securely locked in place.

5. Insert the ball ends of the cables into the equalizer assembly.

6. Install the rear drum(s) and tighten the three Tinnerman nuts and secure the drum. Install the wheel and tire and the wheel cover.

7. Adjust the parking brake linkage.

#### MAVERICK

#### Removal

Refer to Fig. 6.

1. Completely release the parking brake.

2. Raise the vehicle on a hoist.

3. Loosen the adjusting nut and remove rear parking brake cable ball end from the connector.

4. Remove the adjusting nut from the equalizer rod and remove the cable from the equalizer.

5. Compress the pronged retainer at the rear spring front hanger bracket and pull the cable rearward through the bracket.

6. Remove the wheel cover, wheel and tire, and rear brake drum.

7. Remove the self-adjuster springs to allow clearance to remove the cable retainer from the backing plate. Disconnect the rear end of the cable from the parking brake lever on the secondary brake shoe.

8. Compress the pronged retainer at the brake backing plate and pull the cable from the backing plate.

9. Remove the screw from the retainer on the rear spring. Remove the parking brake cable from the retainer and remove the cable from the vehicle.

100% Satisfaction Guaranteed

**BUY IT NOW!**

Click Here To Order

### Installation

Refer to Fig. 6.

1. Insert the forward end of the new parking brake cable through the hole in the rear spring front hanger bracket. Pull the cable through until the cable retainer prongs are firmly seated in the bracket hole.

2. Push the cable rear end through the hole in the brake backing plate and pull into backing plate hole until cable retainer prongs are securely positioned in the backing plate cable hole.

3. Connect the cable end to the parking brake lever on the rear brake secondary shoe and install the brake self-adjuster spring.

4. Install the brake drum, wheel and tire assembly and wheel cover.

5. Position the parking brake cable in the rear spring cable retainer, and install and tighten the nut on the retainer stud.

6. Install the ball end of the cable in the connector.

7. Position the cable in the equalizer and install the equalizer rod adjusting nut.

8. Verify proper operation of the parking brake.

9. Adjust the parking brake. Refer to "Parking Brake Adjustment".

### FAIRLANE, MONTEGO, MUSTANG AND COUGAR— EXCEPT STATION WAGON

#### Removal

1. Remove the equalizer lock nut and adjusting nut, equalizer, spring and spring seat.

2. With the cables slack, disconnect the ball ends from the connector (Figs. 4 and 5).

3. Remove the cable from the retainer hooks (station wagon models) and the underbody guide (convertible models) if required.

4. Remove the hairpin lock retaining the cable housing to the side rail bracket.

5. Remove the wheel cover, wheel and tire and the rear brake drum as outlined in Part 12-02.

6. Remove self-adjuster springs to allow clearance to remove cable retainer from the backing plate. Disconnect the rear end of the cable from the parking brake lever on the

brake shoe. Disengage the cable housing retaining grommet or steel-pronged Hi-Hat from the backing plate and withdraw the cable and housing from the inboard side of the backing plate.

7. Slide the cable and housing out of the side rail bracket.

#### Installation

1. Insert the rear end of the cable through the side rail bracket and pull the cable and housing into position.

2. Insert the rear end of the cable and housing through the hole in the backing plate from the inboard side.

3. Connect the cable to the parking brake lever on the brake shoe and install the cable housing retaining grommet or steel-pronged Hi-Hat in the backing plate.

4. Install the self-adjuster springs. Position the cable housing in the side rail bracket and install the hairpin type retainer.

5. Install rear hub and drum assembly, wheel and tire assemblies and wheel cover as outlined in Section 2.

6. Position the cable retainer hooks (station wagon models) in the underbody guide (convertible models) and install the connector, thus hooking the two cables together.

7. Insert the cable into the equalizer and install the equalizer, spring seat, spring, adjusting nut and lock nut to the front, parking brake control cable.

8. Adjust the parking brake.

### FAIRLANE AND MONTEGO STATION WAGONS AND FALCON PASSENGER MODELS

#### Removal and Installation

Refer to Fig. 4.

Generally follow the procedure given above, omitting separation of the cables, since the parking brake rear cable assemblies supplied for these models is in one piece. Removal and installation of both rear wheels, tires and drums will also be required.

### LINCOLN CONTINENTAL

#### Removal

Refer to Fig. 8.

1. Raise the vehicle.  
2. Loosen the parking brake adjustment nut and disconnect the rear brake cables from the equalizer.

3. Remove the rear cable retaining clips and pull the cables through the left frame side member.

4. Remove the retaining clip that attaches the left rear cable to the lower left arm.

5. Remove the clips that retain the right rear cable to the number 4 crossmember and at the right frame side rail.

6. Remove the rear wheel covers, and the tire and wheel assemblies. Remove the Tinnerman retaining nuts and remove the rear drums.

7. Remove the automatic brake adjuster spring.

8. Compress the parking brake cable housing retainer prongs and pull the retainer through the backing plate hole.

9. Relieve the spring tension and lift the cable end from the parking brake lever.

10. Remove the parking brake cable from the backing plate.

#### Installation

1. Position the parking brake cable through the hole in the backing plate.

2. Relieve the spring tension and install the cable ball end in the parking brake lever slot. Securely seat the retainer prongs in the hole in the backing plate.

3. Install the automatic brake adjuster spring.

4. Install the brake drum and the Tinnerman retaining nuts. Install the wheel and tire assembly and wheel cover.

5. Install the clips that attach the right rear cable to the number 4 crossmember and the clip that retains the cable at the right frame side rail.

6. Install the cable clip that attaches the left rear cable to the left lower arm.

7. Position the cables through the left frame side member and install the retaining clips.

8. Install the cable ends in the equalizer lever.

9. Adjust the parking brakes. Refer to the Parking Brake Adjustment procedures in this manual.

10. Lower the vehicle.



## 4 SPECIFICATIONS

### TORQUE LIMITS-GENERAL-FT-LBS.

	Ford-Mercury Meteor	Fairlane- Montego Falcon	Maverick	Mustang- Cougar	Thunderbird Continental Mark III	Lincoln Continental
Parking Brake Control Assembly Mounting Nuts and Bolts	Cap Screw 12-19	12-25	Cap Screw 8-12	12-25	12-18	Dash Panel 12-25
	Nuts 7-11		Nuts 8-12			Inst. Panel 10-20

CH1730-A

**100% SATISFACTION GUARANTEED**

**BUY IT NOW!**

**Click Here To Order**

PayPal American Express Cards DISCOVER MASTERCARD VISA

# This is only a **Demo** of the product! Only a few pages are included.

**Description:** The Ford Shop Manual is the original manual used by the Ford dealership mechanics at to guide them through repairs and maintenance. Each section provides information on the operation of major systems, diagnostics, troubleshooting, overhaul, as well as the removal and installation of major components. Written in an easy to understand format, this manual contains step-by-step instructions designed for the novice and the expert. In addition, this manual is filled with illustrations, photographs, and diagrams that help in the identification of parts and proper assembly.

Our manuals are fully approved and licensed by the Ford Motor Company

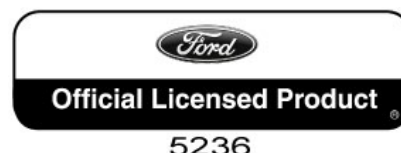

We are a licensed distributor of Adobe Reader



**Adobe Reader:** Unlike some CD-ROM versions on the market, this product is produced in Adobe Reader (pdf) format to retain the exact look and feel of the original manual. Simply scroll through the pages and sections like reading a normal printed manual. In addition, unlike a printed version, each page can be printed (or reprinted, if damaged in the garage), zoom in to over 1200% to see the exact details, and you can search for keywords.

## Product Features:

- ▶ Printable - Print only the pages you need (if a page is damaged in the shop, just print a new one!)
- ▶ Searchable - Search the entire manual in seconds.
- ▶ Zoom - Zoom in to over 1200% to see the exact details.
- ▶ Transportable - Use on any Windows computer. No additional software needed.
- ▶ Bookmarked - Manual is bookmarked to locate sections in seconds.
- ▶ Money Back Guarantee!



*Ford* **Manuals.com**  
We Specialize in Classic Ford Manuals

Visit us online for other great Ford Products:

<p><b>1964</b> <b>COMET</b> and <b>FALCON</b> <b>SHOP MANUAL</b></p>	<p><b>1965</b> <b>COMET,</b> <b>FALCON,</b> <b>FAIRLANE</b> and <b>MUSTANG</b> <b>SHOP MANUAL</b></p>	<p><b>1966</b> <b>COMET,</b> <b>FALCON,</b> <b>FAIRLANE</b> and <b>MUSTANG</b> <b>SHOP MANUAL</b></p>	<p><b>1967</b> <b>COUGAR</b> <b>FAIRLANE</b> <b>FALCON</b> <b>MERCURY</b> INTERMEDIATE <b>MUSTANG</b> <b>SHOP MANUAL</b></p>
<p><b>1968</b> <b>COUGAR</b> <b>FAIRLANE</b> <b>FALCON</b> <b>MONTEGO</b> <b>MUSTANG</b> <b>SHOP MANUAL</b></p>	<p><b>1969</b> CAR <b>SHOP</b> <b>MANUAL</b> <b>VOLUME ONE</b></p> <p>FALCON FAIRLANE MUSTANG FORD THUNDERBIRD MONTEGO COUGAR METEOR MERCURY LINCOLN CONTINENTAL CONTINENTAL MARK III</p>	<p><b>1970</b> CAR <b>SHOP</b> <b>MANUAL</b> <b>VOLUME ONE</b></p> <p>METEOR MAVERICK FALCON FAIRLANE MUSTANG FORD THUNDERBIRD MONTEGO COUGAR MERCURY LINCOLN CONTINENTAL CONTINENTAL MARK III</p>	<p><b>1971</b> CAR <b>SHOP</b> <b>MANUAL</b> <b>VOLUME ONE</b></p> <p>MAVERICK TORINO MUSTANG FORD THUNDERBIRD MONTEGO COUGAR COMET METEOR MERCURY LINCOLN CONTINENTAL CONTINENTAL MARK III</p>
<p><b>1972</b> car shop manual <b>VOLUME I</b></p> 	<p><b>1973 CAR SHOP MANUAL</b></p>  <p><b>Volume 1</b> <b>Chassis</b></p>	<p><b>1965/72</b> <b>FORD CAR</b> FINAL ISSUE</p> <p>Master Parts and Accessories CATALOG</p> <p>Form FP 7635-A &amp; B</p> <p>Supersedes All Previous Issues, Changes and Revisions</p> <p>Official_FordDiagrams.com_Extract</p> <p>May, 1975</p>	

**100% SATISFACTION GUARANTEED**

**BUY IT NOW!**

**Click Here To Order**



*Ford* **Manuals.com**  
We Specialize in Classic Ford Manuals