

9997

Colorized

**Mustang
Wiring & Vacuum
Diagrams**

(with Electrical Illustrations)

Free Bonus!
30-Minute Video
Ford Training
Course 13001, Vol 68 S7
"How to Read Wiring
Diagrams"
Included!

A consolidated collection of original Ford electrical & vacuum diagrams with illustrations

Color diagrams for:

- Air Conditioner/Heater/Defroster
 - Convertible Top
 - Exterior Lights/Turn Signals/Brakes
 - Ignition, Starting and Charging
 - Instrument Panel
 - Interior Lights/Clock/Cigar Lighter
 - Radio, Stereo and Speakers
 - Seat Belt Warning Light and Horns
 - Speed Control
 - Tilt Wheel
 - Windshield Wiper and Washer
- ...and much more!!

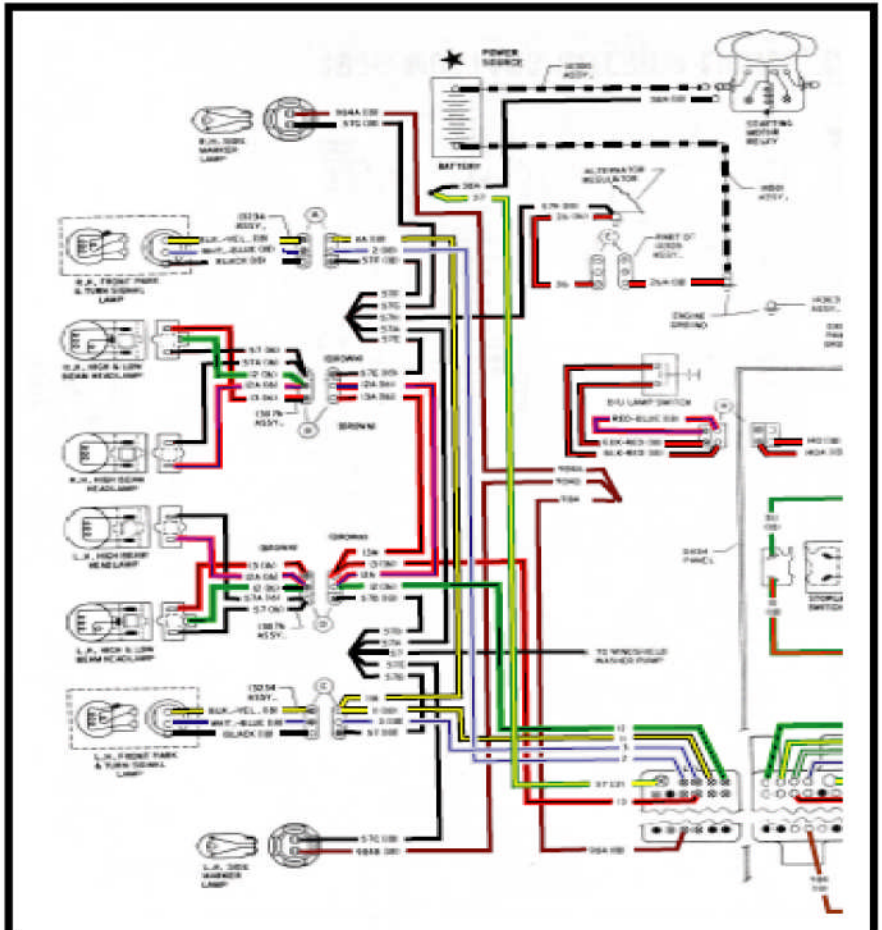

Example of colorized diagrams

Licensed and approved
by the Ford Motor Company

100% SATISFACTION GUARANTEED

BUY IT NOW!

Click Here To Order

Copyright © 2008, Forel Publishing Company, LLC, Woodbridge, Virginia

All Rights Reserved. No part of this book may be used or reproduced in any manner whatsoever without written permission of Forel Publishing Company, LLC. For information write to Forel Publishing Company, LLC, 3999 Peregrine Ridge Ct., Woodbridge, VA 22192

1969 Colorized Mustang Wiring and Vacuum Diagrams
(Extracted from Form 7098-69-3, Form FD-7795P-69, FD-7943-69,
FP-7635B, and FD-7943-G)
EAN: 978-1-60371-028-2
ISBN: 1-60371-028-0

Forel Publishing Company, LLC
3999 Peregrine Ridge Ct.
Woodbridge, VA 22192
Email address: webmaster@ForelPublishing.com
Website: <http://www.ForelPublishing.com>



This publication contains material that is reproduced and distributed under a license from Ford Motor Company. No further reproduction or distribution of the Ford Motor Company material is allowed without the express written permission of Ford Motor Company.

Note from the Editor

This product was compiled using several original Ford Motor Company publications. In some cases, there are slight differences between publications, so it is important to compare between diagrams, schematics, or illustrations. The contents of this product were extracted from: *1969 Car Shop Manual* (Form 7098-69-1/5, November 1968), *1965/1972 Ford Car Master Parts and Accessory Catalog* (Form FP-7635B, May 1975, and *1969 Wiring Diagrams* (Form FD-7795P-69 & FD-7943-69) and *How to Read Wiring Diagrams* (FD-7943-G).

Disclaimer

Although every effort was made to ensure the accuracy of this book, no representations or warranties of any kind are made concerning the accuracy, completeness or suitability of the information, either expressed or implied. As a result, the information contained within this book should be used as general information only. The author and Forel Publishing Company, LLC shall have neither liability nor responsibility to any person or entity with respect to any loss or damage caused, or alleged to be caused, directly or indirectly by the information contained in this book. Further, the publisher and author are not engaged in rendering legal or other professional services. If legal, mechanical, electrical, or other expert assistance is required, the services of a competent professional should be sought.

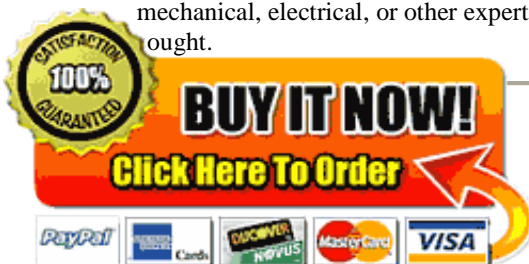



ATTENTION

Please Read This



It is important to note that differences exist between similar or like wiring diagrams even though they are original Ford publications. It is for this reason there may be multiple versions of what appears to be the same wiring diagram. If your vehicle has a color coded wire that does not match a diagram you should consult the other diagrams contained in the manual for a possible match.

Example of differences

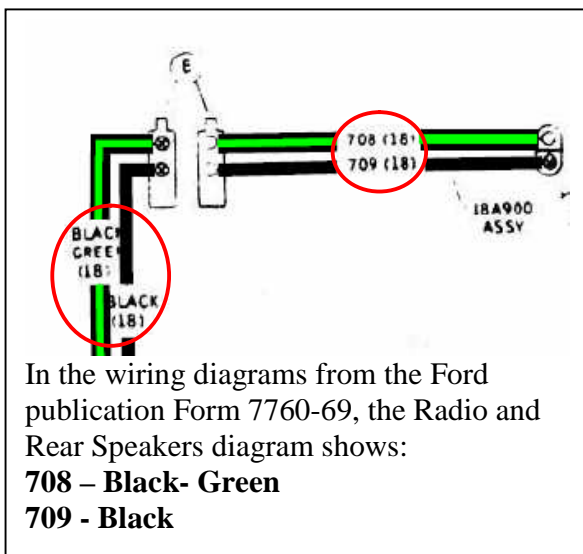

WIRING COLOR CODE	
6	RED - GREEN
6A	PINK
71	YELLOW
762	BROWN
740	RED - YELLOW
708	BLACK
709	BLACK - GREEN
904	VIOLET

In the Wiring Color Code section of the exact same page shows:

- 708 – Black**
- 709 – Black-Green**

The color coded wiring diagrams are provided for illustration purposes only. Only the wire number should be used for the identification of the wire itself. The color coding of the wires in the product may not match the actual colors of the wires in the vehicle. In some cases, the colors have been altered to provide a visual contrast (i.e. the color white has been shaded to make it more visible). As stated in the paragraph above, there are some variation and/or differences between the original Ford wiring diagrams. If your vehicle has a color coded wire that does not match a diagram you should consult the other diagrams contained in the manual for a possible match.

Disclaimer: Although every effort was made to ensure the accuracy of this book, no representations or warranties of any kind are made concerning the accuracy, completeness or suitability of the information, either expressed or implied. As a result, the information contained within this book should be used as general information only. The author and Forel Publishing Company, LLC shall have neither liability nor responsibility to any person or entity with respect to any loss or damage caused, or alleged to be caused, directly or indirectly by the information contained in this book. Further, the publisher and author are not engaged in rendering legal or other professional services. If legal, mechanical, electrical, or other expert assistance is required, the services of a competent professional should be sought.

100% SATISFACTORY GUARANTEED

BUY IT NOW!

Click Here To Order

PayPal American Express Discover MasterCard VISA

1969 Color Wiring Codes

Number	Wire Description	Source
2	WHITE-BLUE STRIPE	Form 7760-69
3	GREEN-WHITE STRIPE	Form 7760-69
4	WHITE-BLACK STRIPE	Form 7760-69
5	ORANGE-BLUE STRIPE	Form 7760-69
8	ORANGE-YELLOW STRIPE	Form 7760-69
9	GREEN-ORANGE STRIPE	Form 7760-69
10	GREEN-RED STRIPE	Form 7760-69
11	GREEN-YELLOW STRIPE	FD-7795P-69
11	BLACK-YELLOW STRIPE	FD-7795P-69
11A	BLACK-YELLOW STRIPE	FD-7795P-69
12	GREEN-BLACK STRIPE	FD-7795P-69
12A	RED-BLUE STRIPE	FD-7795P-69
12B	RED-BLUE STRIPE	FD-7795P-69
13	RED-BLACK STRIPE	FD-7795P-69
14	BLACK	FD-7795P-69
15	RED-YELLOW STRIPE	FD-7795P-69
16	RED-GREEN STRIPE	Form 7760-69
16	PINK	Form 7760-69
16A	PINK	Form 7760-69
19	BLUE-RED STRIPE	Form 7760-69
19A	BLUE-RED STRIPE	Form 7760-69
19B	BLUE-RED STRIPE	Form 7760-69
19C	BLUE-RED STRIPE	Form 7760-69
19D	BLUE-RED STRIPE	Form 7760-69
19E	BLUE-RED STRIPE	Form 7760-69
21	YELLOW	Form 7760-69
22	BLUE-BLACK STRIPE	Form 7760-69
25	BLACK-ORANGE STRIPE	Form 7760-69
26	BLACK-RED STRIPE	Form 7760-69
26A	BLACK-RED STRIPE	Form 7760-69
26A	BLACK	Form 7760-69
28	BLACK	Form 7760-69
29	Unknown	Form 7760-69
30	BLACK-GREEN STRIPE	Form 7760-69
30	VIOLET	Form 7760-69
30A	VIOLET (Resistance Wire)	Form 7760-69
31	WHITE-RED STRIPE	Form 7760-69
32	RED-BLUE STRIPE	Form 7760-69
32A	RED-BLUE STRIPE	Form 7760-69
	Unknown	Form 7760-69
		Form 7760-69

Number	Wire Description	Source
35	ORANGE	Form 7760-69
37	BLACK-YELLOW STRIPE	Form 7760-69
37	GREEN-YELLOW STRIPE	Form 7760-69
37A	BLACK-YELLOW STRIPE	Form 7760-69
38	BLACK	Form 7760-69
38A	BLACK	Form 7760-69
38B	BLACK	Form 7760-69
39	RED-WHITE STRIPE	Form 7760-69
40	BLUE-WHITE STRIPE	Form 7760-69
44	BLUE	FD-7795P-69
48	Unknown	Form 7760-69
49	WHITE-BLUE STRIPE	Form 7760-69
50	GREEN-WHITE STRIPE	Form 7760-69
53	BLACK-BLUE STRIPE	Form 7760-69
53A	BLACK-BLUE STRIPE	Form 7760-69
53B	BLACK-BLUE STRIPE	Form 7760-69
53C	BLACK-BLUE STRIPE	Form 7760-69
53D	BLACK-BLUE STRIPE	Form 7760-69
53E	BLACK-BLUE STRIPE	Form 7760-69
53F	BLACK-BLUE STRIPE	Form 7760-69
54	GREEN-YELLOW STRIPE	Form 7760-69
54A	GREEN-YELLOW STRIPE	Form 7760-69
54B	GREEN-YELLOW STRIPE	Form 7760-69
54C	GREEN-YELLOW STRIPE	Form 7760-69
54D	GREEN-YELLOW STRIPE	Form 7760-69
54A	YELLOW-GREEN STRIPE	Form 7760-69
54B	YELLOW-GREEN STRIPE	Form 7760-69
54C	YELLOW-GREEN STRIPE	Form 7760-69
54D	YELLOW-GREEN STRIPE	Form 7760-69
54E	YELLOW-GREEN STRIPE	Form 7760-69
54F	YELLOW-GREEN STRIPE	Form 7760-69
57	BLACK	Form 7760-69
57A	BLACK	Form 7760-69
57B	BLACK	FD-7795P-69
57C	BLACK	FD-7795P-69
57D	BLACK	FD-7795P-69
57E	BLACK	FD-7795P-69
57F	BLACK	FD-7795P-69
57H	BLACK	FD-7795P-69
58	WHITE	Form 7760-69
63	RED	Form 7760-69

100% SATISFACTION GUARANTEED

BUY IT NOW!

Click Here To Order

PayPal American Express Discover MasterCard VISA

Number	Wire Description	Source
87	GREEN-ORANGE STRIPE	Form 7760-69
122	YELLOW	Form 7760-69
123	RED	Form 7760-69
137	YELLOW-BLACK STRIPE	Form 7760-69
140	BLACK-RED STRIPE	Form 7760-69
140A	BLACK-RED STRIPE	Form 7760-69
152	YELLOW	Form 7760-69
152	GREEN-BLACK STRIPE	Form 7760-69
152A	YELLOW	Form 7760-69
161	GREEN-RED STRIPE	Form 7760-69
162	GREEN	Form 7760-69
175	BLACK	Form 7760-69
257	YELLOW	Form 7760-69
262	BROWN	Form 7760-69
268	RED	Form 7760-69
269	BLUE	Form 7760-69
270	BLACK	Form 7760-69
296	RED	Form 7760-69
297	BLACK-GREEN STRIPE	Form 7760-69
297	BLUE-GREEN STRIPE	Form 7760-69
297	YELLOW-GREEN STRIPE	Form 7760-69
297A	BLACK-GREEN STRIPE	Form 7760-69
375	YELLOW-BLACK STRIPE	Form 7760-69
375A	YELLOW-BLACK STRIPE	Form 7760-69
383	RED-WHITE STRIPE	Form 7760-69
385	WHITE-RED STRIPE	Form 7760-69
442	GREEN-ORANGE STRIPE	Form 7760-69
443	GREEN-RED STRIPE	Form 7760-69
444	GREEN-BLACK STRIPE	Form 7760-69
445	ORANGE-BLUE STRIPE	Form 7760-69
446	ORANGE-WHITE STRIPE	Form 7760-69
447	ORANGE-RED STRIPE	Form 7760-69
448	GREEN-WHITE STRIPE	Form 7760-69
449	WHITE-BLUE STRIPE	Form 7760-69
460	YELLOW	Form 7760-69
469	Unknown	Form 7760-69
482	BLUE-YELLOW STRIPE	Form 7760-69
482A	BLUE-YELLOW STRIPE	Form 7760-69
490	BLUE-RED STRIPE	Form 7760-69
	GREEN	Form 7760-69
		Form 7760-69

Number	Wire Description	Source
591	BLACK-ORANGE STRIPE	Form 7760-69
592	BLUE-WHITE STRIPE	Form 7760-69
593	YELLOW	Form 7760-69
640	RED-YELLOW STRIPE	Form 7760-69
640A	RED-YELLOW STRIPE	Form 7760-69
643	YELLOW-BLACK STRIPE	Form 7760-69
654	YELLOW	Form 7760-69
655	RED	Form 7760-69
704	VIOLET	Form 7760-69
708	BLACK	Form 7760-69
709	GREEN-BLACK STRIPE	Form 7760-69
763	ORANGE-WHITE STRIPE	Form 7760-69
806	WHITE	Form 7760-69
807	ORANGE	Form 7760-69
904	VIOLET	Form 7760-69
904	GREEN-RED STRIPE	Form 7760-69
923	VIOLET	Form 7760-69
914	Unknown	Form 7760-69
924	RED	Form 7760-69
925	WHITE	Form 7760-69
950	WHITE-BLACK STRIPE	Form 7760-69
951	GREEN	Form 7760-69
977	Unknown	Form 7760-69
984	BROWN	Form 7760-69

Note – wire color codes highlighted in **RED** designate a difference either between the original Ford wiring publications or within the same publication. Those highlighted have the same wire number but have different color codes.

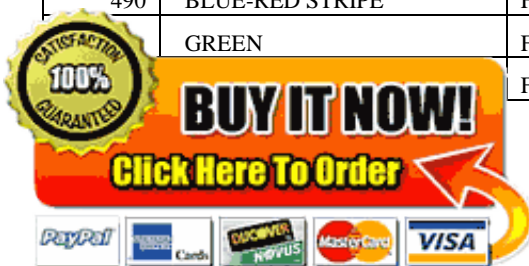

































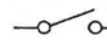

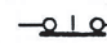
100% GUARANTEED
BUY IT NOW!
 Click Here To Order

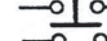
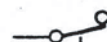
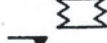
WIRE SYMBOLS

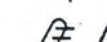







-  HEATER
-  CIRCUIT BREAKER
-  FUSE
-  RESISTOR OR RESISTANCE WIRE
-  DIODE
-  CAPACITOR OR CONDENSER
-  THERMOSTAT (VARIABLE RESISTANCE)
-  THERMISTOR
-  SPARK PLUG
-  GROUND
-  BATTERY
-  MAINTAINED CONTACT
-  MOMENTARY CONTACT
-  SPLICE, WELD OR SOLDER POINT
-  SPLICED WIRES
-  CROSSOVER WIRE (NO CONNECTION)
-  JUNCTION BLOCK
-  HORN
-  BUSS BAR
-  BUS BAR & SPLICE

SWITCHES



-  N.O. (SPST)
-  N.O. (SPST)
-  N.O. (DPST)
-  PUSH TYPE N.C.
-  PUSH TYPE N.O.
-  PUSH TYPE N.O. MULTIPLE POLE
-  PRESSURE OR VACUUM OPERATED N.C.
-  (SPDT) CENTER OFF
-  ROTARY SWITCH
-  MERCURY SWITCH
-  THERMAL SWITCH INTERNAL HEATER N.C.
-  THERMAL SWITCH INTERNAL HEATER N.C.
-  THERMAL SWITCH EXTERNAL HEATER N.C.

N.O. - NORMALLY OPEN
 N.C. - NORMALLY CLOSED
 S.P.S.T. - SINGLE POLE, SINGLE THROW
 D.P.S.T. - DOUBLE POLE, SINGLE THROW
 S.P.D.T. - SINGLE POLE, DOUBLE THROW
 D.P.D.T. - DOUBLE POLE, DOUBLE THROW

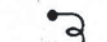

RELAYS

-  N.O. (SPST)
-  N.C. (SPST)
-  SPDT
-  N.O. DPST
-  N.C. DPST
-  SOLENOID
-  COIL AIR CORE
-  IGNITION COIL





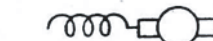





LAMPS

-  SINGLE FILAMENT
-  DOUBLE FILAMENT

MOTORS

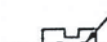
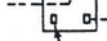
-  BASIC SERIES
-  SPLIT SERIES
-  PERMANENT MAGNET

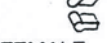
CONNECTORS

-  FEMALE CONNECTOR
-  OFF SET
-  MALE CONNECTOR
-  CONNECTOR NOT USED
-  BULLET CONNECTOR
-  SPADE NOT USED
-  FEMALE SPADE CONNECTOR
-  MALE SPADE CONNECTOR
-  MULTIPLE PLUG
-  COVER FOR CONNECTOR PINS
-  IGNITION SWITCH

- AND/OR * WIRE FUNCTION NOT APPLICABLE TO THIS CIRCUIT
 (14), (16) ETC. ALL NUMBERS IN (A), (B) ETC. ALL LETTERS CIRCLED INDICATE CONNECTION LOCATION.
 ★ TO POWER SOURCE

Source Document
Ford Publication Form 7795P-69

1969

COURSE 13003 and 1703

WIRING and VACUUM DIAGRAMS



**SERVICE
TRAINING**

BUY IT NOW!
Click Here To Order

100% SATISFACTION GUARANTEE

FORM 7795P-69

1969 MUSTANG AND COUGAR ELECTRICAL DRAWINGS

SECTION 2 INDEX

AIR CONDITIONER

Mustang & Cougar 2-E32 & E33

BRAKE LIGHTS

Mustang 2-E22, E24 & E25
Cougar 2-E18, E20 & E21

CHARGING

Mustang 2-E6, E7 & E8
Cougar 2-E10 & E11
Cougar XR7 2-E12 & E13

CIGAR LIGHTER

Mustang 2-E22 & E23
Cougar 2-E14, E15 & E16

CIRCUIT PROTECTION

Mustang & Cougar 2-E37

CLOCK

Mustang 2-E22 & E23
Cougar 2-E14, E15 & E16

CONVENIENCE SYSTEMS

Cougar 2-E17
Cougar XR7 (Prove Out) 2-E12 & E13

CONVERTIBLE TOP

Mustang & Cougar 2-E30

DEFOGGER

Cougar 2-E31

EXTERIOR LIGHTS

Mustang 2-E24 & E25
Cougar 2-E18, E19, E20 & E21

GAUGES

Mustang 2-E6, E7 & E8
Cougar 2-E10 & E11
Cougar XR7 2-E12 & E13

HEATER AND DEFROSTER

Mustang & Cougar 2-E32 & E33

HORNS

Mustang & Cougar 2-E36

IGNITION

Mustang 2-E6, E7 & E8
Cougar 2-E10 & E11
Cougar XR7 2-E12 & E13

INSTRUMENT PANEL

Mustang 2-E2
Cougar 2-E3
Cougar XR7 2-E4

INTERIOR LIGHTS

Mustang 2-E22 & E23
Cougar 2-E16
Cougar XR7 2-E14 & E15

NEUTRAL SWITCH

Mustang 2-E6
Cougar 2-E10

POWER WINDOWS

Cougar 2-E26 & E27

RADIO AND STEREO TAPE

Mustang & Cougar 2-E34 & E35

SEAT BELT REMINDER LIGHTS

Mustang & Cougar 2-E36

SPEED CONTROL

Mustang & Cougar 2-E5

STARTING

Mustang 2-E6, E7 & E8
Cougar 2-E10 & E11
Cougar XR-7 2-E12 & E13

TACHOMETER

Mustang 2-E6 & E7
Cougar 2-E10, E12 & E13

TILT WHEEL

Mustang & Cougar 2-E9

TURN SIGNALS

Mustang 2-E24 & E25
Cougar 2-E20 & E21

WINDSHIELD WIPERS AND

WASHERS

Mustang & Cougar 2-E28
Mustang & Cougar (Intermittent) 2-E29

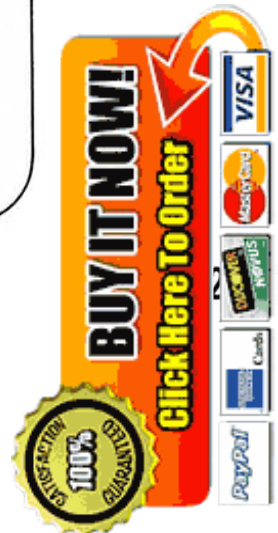

HOW TO USE THE WIRING DIAGRAMS

THE INDEX PAGE IS THE FIRST PAGE IN EACH SECTION. EACH ELECTRICAL SCHEMATIC WILL HAVE A NOTATION AS TO THE SOURCE OF POWER FOR THAT SYSTEM. ALL WIRES WILL BE SHOWN AS SINGLE LINES TO PROVIDE A CLEAR UNDERSTANDING OF THE DIAGRAMS. TO TRACE A CIRCUIT, IT IS RECOMMENDED TO START AT THE GROUND CIRCUIT OF THE INOPERATIVE COMPONENT, TRACE IT THROUGH ALL CONNECTORS TO THE SOURCE, AND NOTE THE POSSIBLE TROUBLE AREAS AND POINTS OF MOST CONVENIENT ACCESS. WIRE CONNECTORS WILL BE IDENTIFIED ON THE SCHEMATIC AND THE PICTORIAL DRAWINGS, THIS WILL SHOW THE TECHNICIAN THE LOCATION OF THE CONNECTORS. MOST WIRE CONNECTORS ARE SHOWN IN OPEN BOOK FASHION. A WIRE ON THE TOP RIGHT OF A CONNECTOR (OPEN SIDE BY SIDE) WILL BE ON THE TOP LEFT SIDE OF THE OTHER HALF OF THE CONNECTOR. SEE FIGURE 1 (WIRE #140 TO #140A, ETC.).

WIRE DISCONNECTS AND CONNECTORS WILL ALL BE BLACK UNLESS A COLOR CODE IS NOTED ON THE DIAGRAM. THE COLORED DISCONNECTS AND CONNECTORS ARE TO AID THE TECHNICIAN IN FINDING THE PROPER CIRCUIT TO BE TESTED OR TRACED. THE ELECTRICAL SYMBOLS AND THEIR MEANINGS ARE NOTED ON EACH DIVIDER PAGE TO PROVIDE A CLEARER UNDERSTANDING OF THE DIAGRAMS. PICTORIAL DRAWINGS OF A COMPONENT WILL INCLUDE THE SPECIFIC LOCATION OF SOME COMPONENTS IN CASES WHERE IT IS DIFFICULT TO DETERMINE IF THE COMPONENT IS UNDER THE INSTRUMENT PANEL OR IN THE ENGINE COMPARTMENT.

RELAYS AND SWITCHES ARE SHOWN IN THE "SYSTEM OFF" POSITION. IF A VEHICLE SPECIFIC WIRE COLOR IN A CONNECTOR DOES NOT MATCH THE DIAGRAM SHOWN, IT CAN USUALLY BE IDENTIFIED BY COMPARING THE OTHER COLORS SHOWN AT THE WIRE CONNECTORS. SPECIFIC WIRE COLOR DEVIATIONS IN THE MANUFACTURING OF A WIRE HARNESS ARE USUALLY FOR A SHORT DURATION.

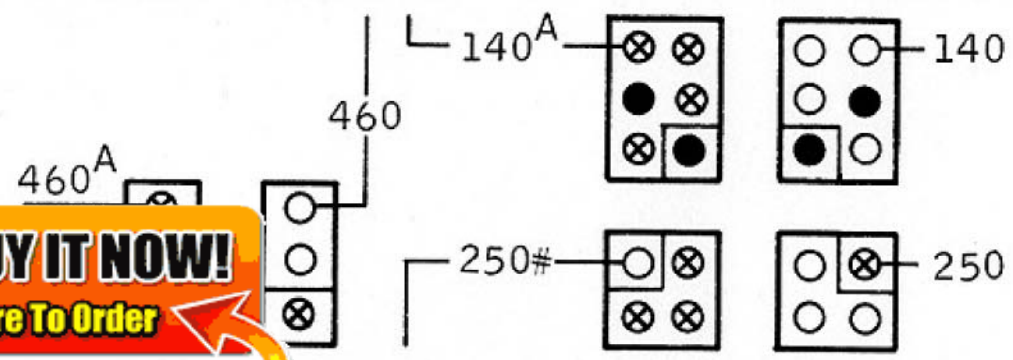
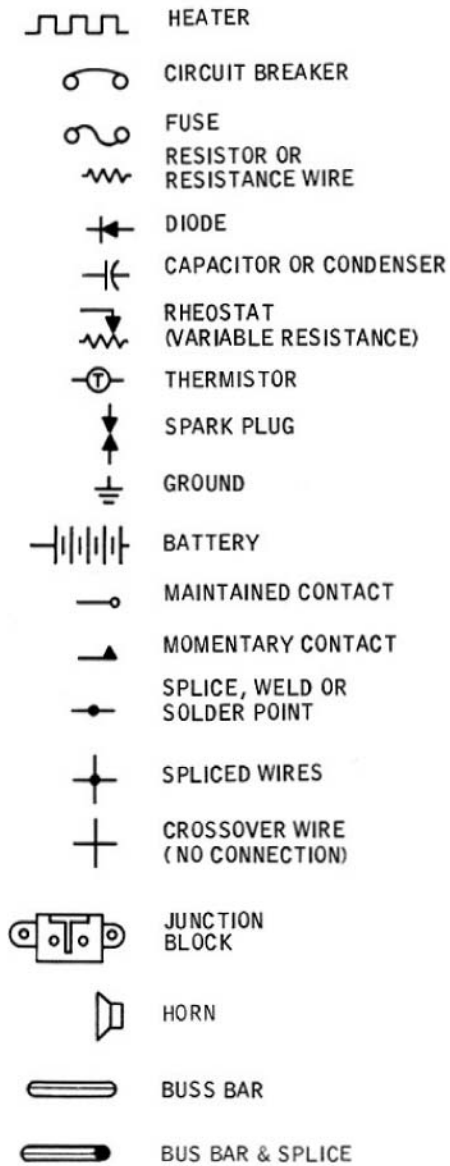

Figure 1

100% SATISFACTION GUARANTEED
BUY IT NOW!
Click Here To Order

PayPal | American Express | Discover | MasterCard | VISA

CIRCUIT SYMBOLS



SWITCHES

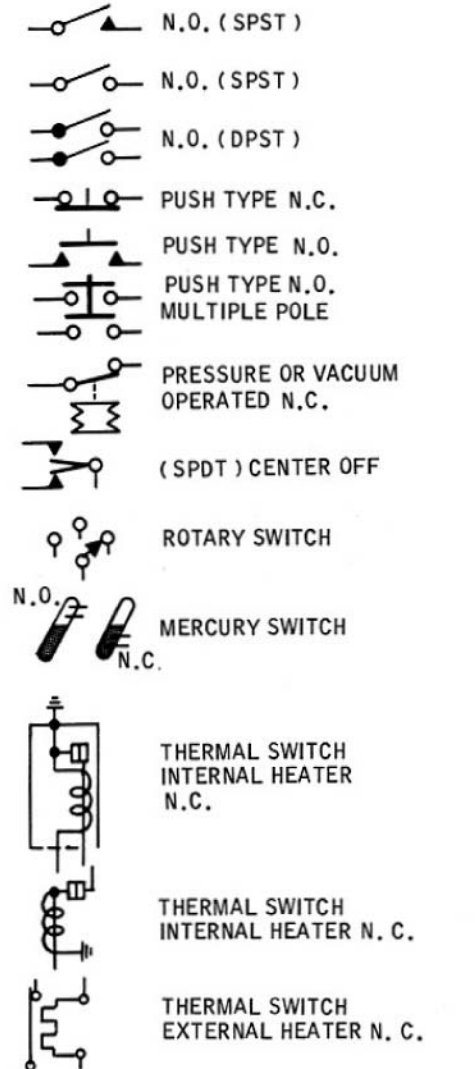

N.O. - NORMALLY OPEN
 N.C. - NORMALLY CLOSED
 S.P.S.T. - SINGLE POLE, SINGLE THROW
 D.P.S.T. - DOUBLE POLE, SINGLE THROW
 S.P.D.T. - SINGLE POLE, DOUBLE THROW
 D.P.D.T. - DOUBLE POLE, DOUBLE THROW

RELAYS

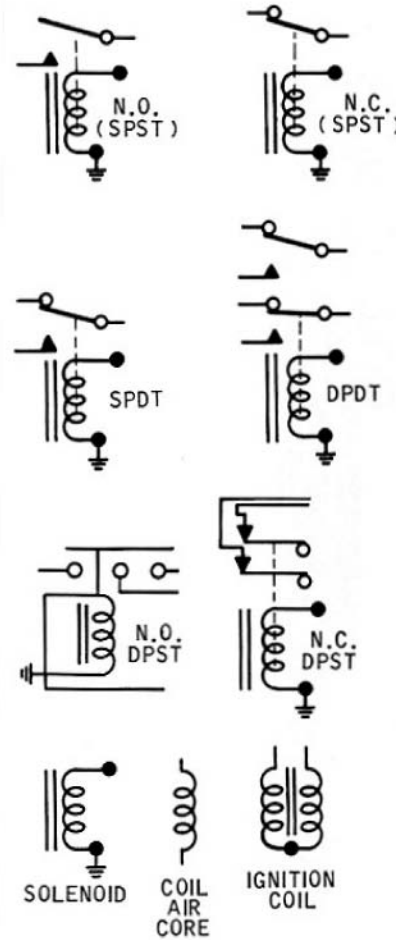

LAMPS

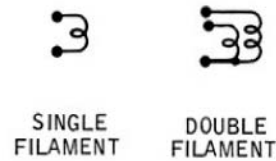

MOTORS

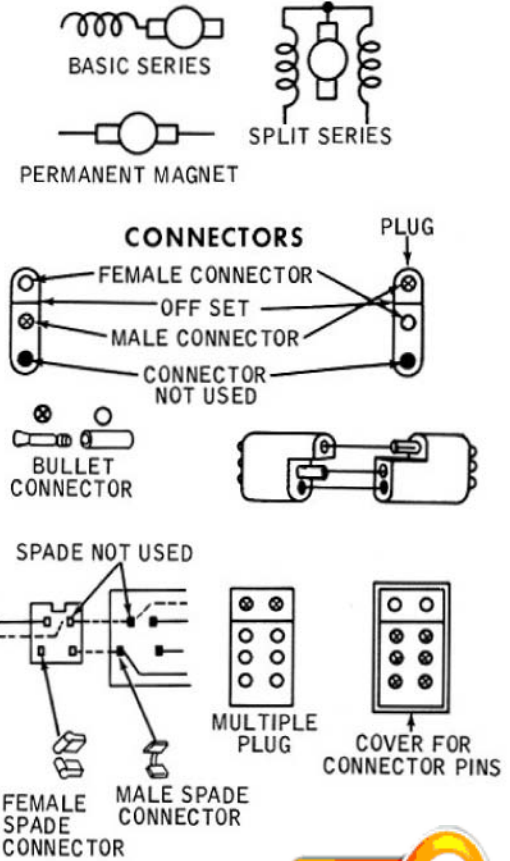

IGNITION

~ AND/OR * WIRE FUNCTION TO THIS CIRCUIT (14), (16) ETC. ALL PARENTHESIS () INDICATE CONNECTIONS (A), (B), ETC. ALL INDICATE CONNECTIONS TO POWER SOURCE

BUY IT NOW!
 Click Here To Order

100% SATISFACTION GUARANTEE

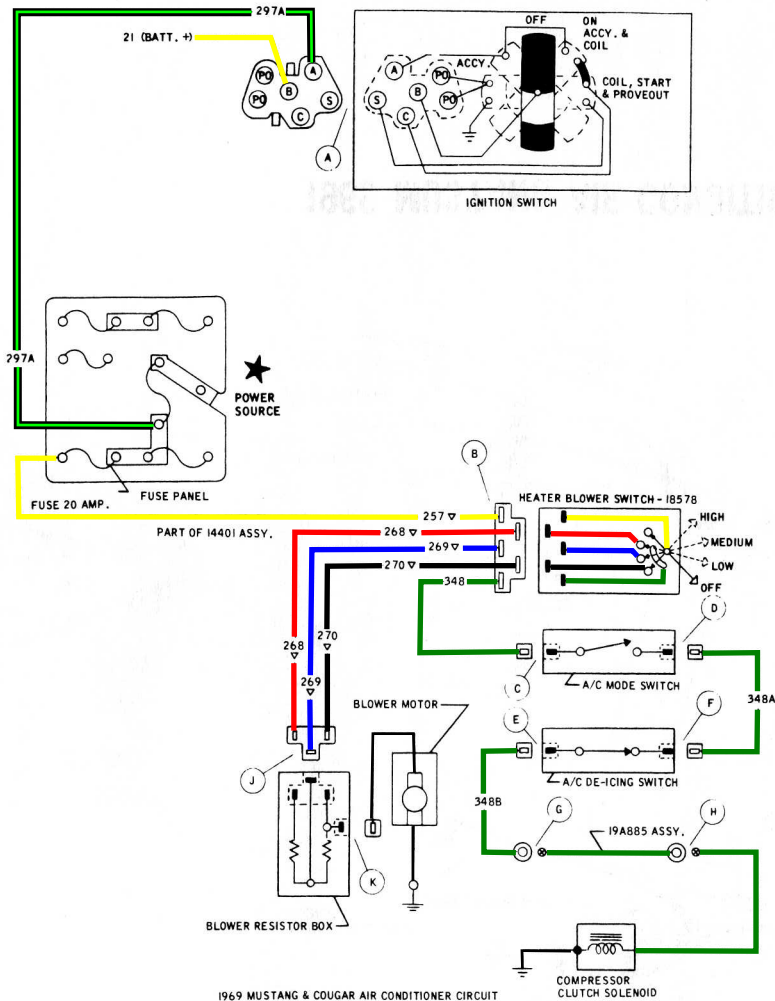

1969 MUSTANG & COUGAR AIR CONDITIONER CIRCUIT

NOTE: DETAIL & ITEM REFERENCE SHOWN ON PRODUCT DRAWING UNLESS OTHERWISE SPECIFIED ALL CONNECTORS ARE BLACK
 ▽ FMVSS STANDARDS APPLY WHERE NOTED.
 ● SPLICE
 ⊕ GROUND
 (A) ALL LETTERS CIRCLED AS SHOWN INDICATE CONNECTORS

WIRING COLOR CODE

21	YELLOW
257	YELLOW
268	RED
269	BLUE
270	BLACK
297A	BLACK-GREEN
348-A-B	GREEN

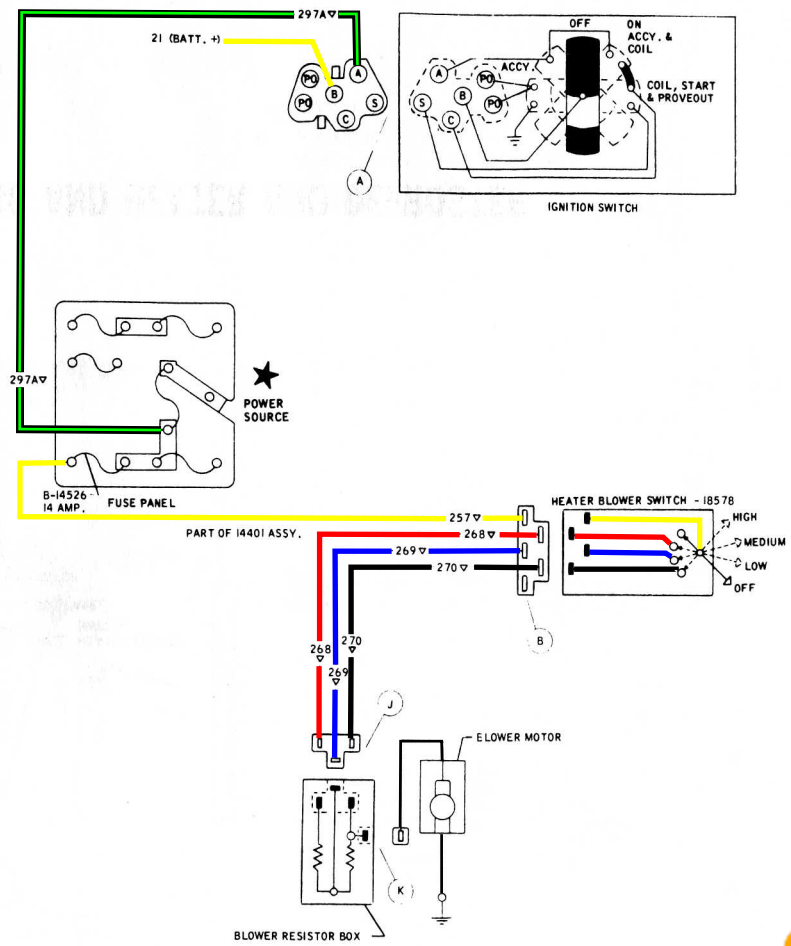

1969 MUSTANG & COUGAR HEATER CIRCUIT

NOTE: DETAIL & ITEM REFERENCE SHOWN ON PRODUCT DRAWING UNLESS OTHERWISE SPECIFIED ALL CONNECTORS ARE BLACK
 ▽ FMVSS STANDARDS APPLY WHERE NOTED.
 ● SPLICE
 ⊕ GROUND
 (A) ALL LETTERS CIRCLED AS SHOWN INDICATE CONNECTORS

WIRING COLOR CODE

21	YELLOW
257	YELLOW
268	RED
269	BLUE
270	BLACK
297A	BLACK-GREEN

1969 MUSTANG AIR CONDITIONING AND HEATER AND DEFROSTER

BUY IT NOW!
 Click Here To Order

100% GUARANTEED
 SATISFACTION

VISA
 MasterCard
 Discover
 American Express
 PayPal







100% SATISFACTION GUARANTEED

BUY IT NOW!

Click Here To Order

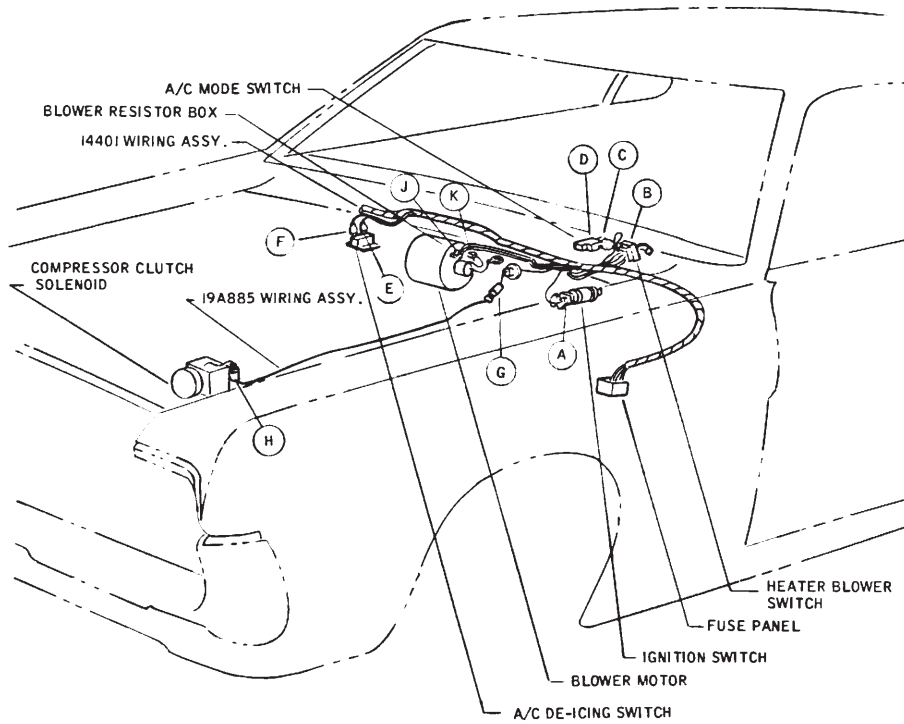

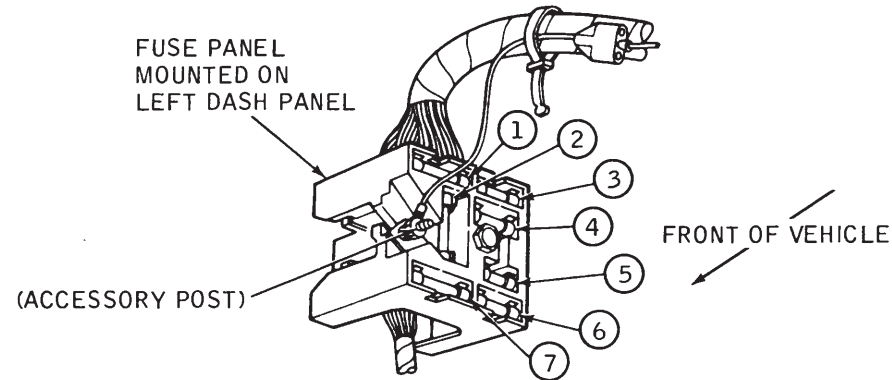

- ① (20 AMP.) TURN SIGNALS, BACK-UP LAMPS, WINDSHIELD WASHER, RADIO FEED AND PRNDL LAMP (AUTO. TRANS.)
 - ② (20 AMP.) (ACCESSORY FEED) SEAT BELT WARNING (RPO), SWING TILT COLUMN (RPO) SAFETY CONVENIENCE CIRCUIT-DOOR AJAR, LOW FUEL, POWER WINDOW SAFETY RELAY FEED, SPEED CONTROL
 - ③ (14 AMP.) HEATER AND DEFROSTER
(30 AMP.) AIR CONDITIONER
 - ④ (SPARE)
 - ⑤ (4 AMP.) INSTRUMENT AND CLUSTER LAMPS, RADIO, HEATER CONTROLS, CLOCK, ASH TRAY LAMP
 - ⑥ (14 AMP.) COURTESY, INSTRUMENT, DOOR, DOME, MAP, GLOVE BOX, "C" PILLAR, LUGGAGE COMPARTMENT LAMP, CLOCK FEED, CIGAR LIGHTER
 - ⑦ (20 AMP.) EMERGENCY WARNING
- NOTE: (30 AMP. REQUIRED FOR AIR/COND.)

1969 MUSTANG AND COUGAR CIRCUIT PROTECTION

1969 MUSTANG CONVERTIBLE TOP

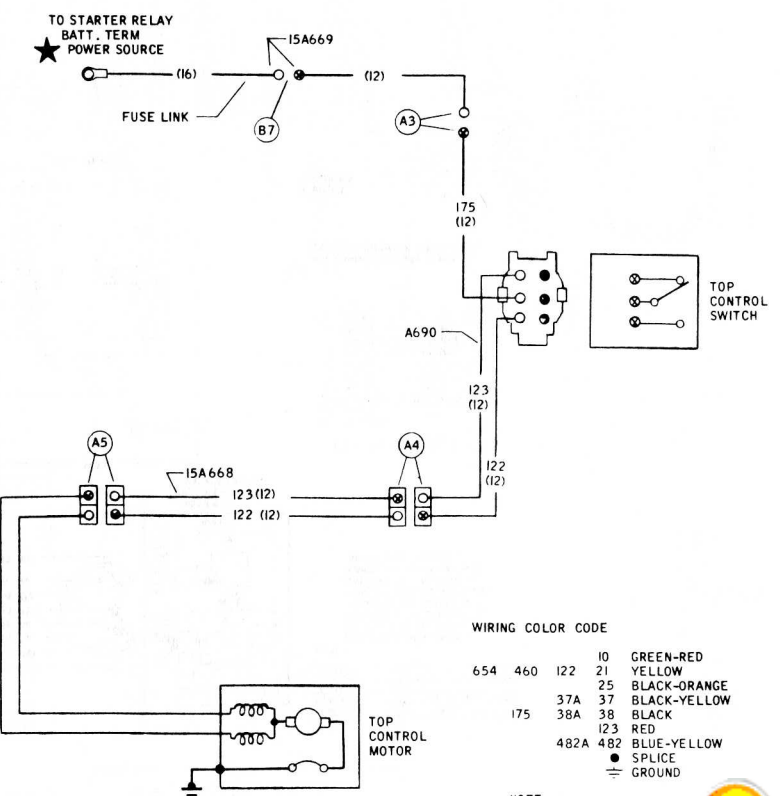
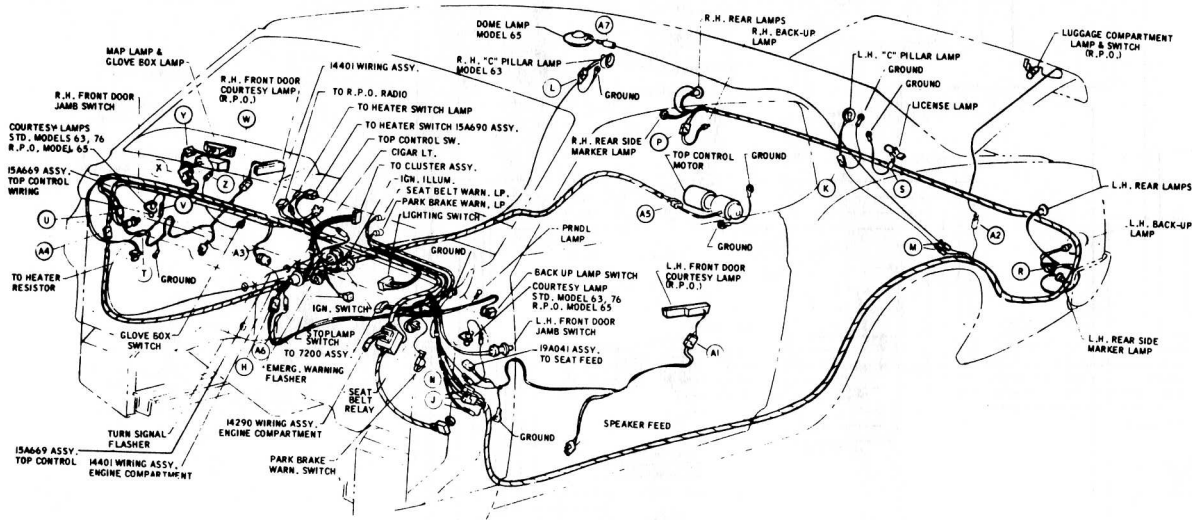

1969 MUSTANG CONVERTIBLE TOP

BUY IT NOW!

Click Here To Order

100% GUARANTEED

VISA

MasterCard

Discover

Amex

PayPal

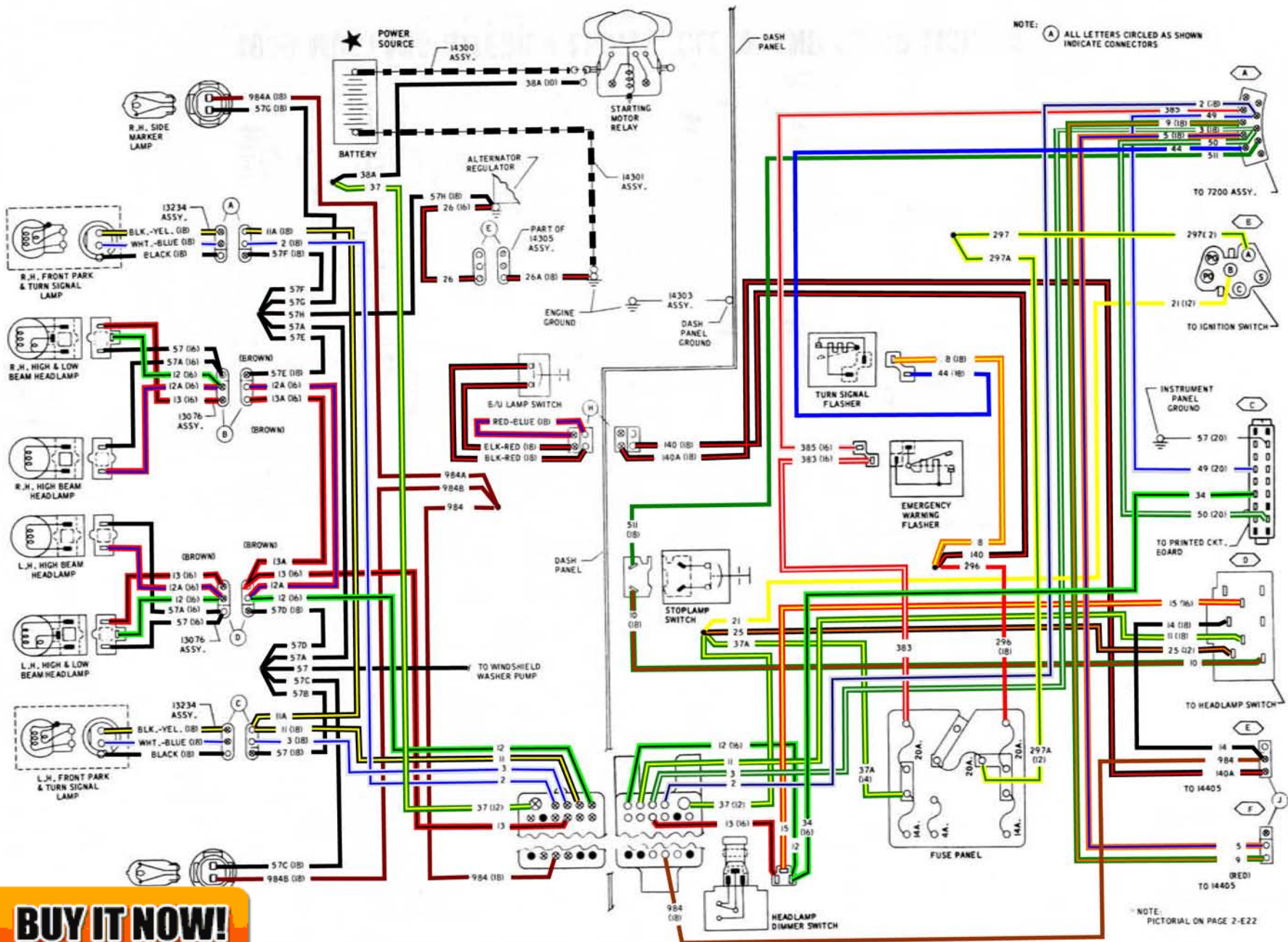

100% SATISFACTION GUARANTEED

BUY IT NOW!

Click Here To Order

PayPal American Express Discover MasterCard VISA

1969 MUSTANG EXTERIOR LIGHTS, TURN SIGNALS AND BRAKE LIGHTS

NOTE: PICTORIAL ON PAGE 2-E22

Source Document
Ford Publication Form 7795P-69

1969

COURSE 13003 and 1703

WIRING and VACUUM DIAGRAMS



**SERVICE
TRAINING**

BUY IT NOW!

Click Here To Order



FORM 77

TABLE OF CONTENTS

MUSTANG-GROUP 2

TOTAL VACUUM SCHEMATIC	2-V2
SWING - AWAY STEERING WHEEL	
ILLUSTRATION	2-V3
SELECTAIRE AIR CONDITIONER	
DIAGNOSIS CHART AND SCHEMATIC	2-V4
INSTALLATION DRAWING—ENGINE COMPARTMENT	2-V5
INSTALLATION DRAWING—PASSENGER COMPARTMENT	2-V6
POWER VENTILATION HEATER	
DIAGNOSIS CHART AND SCHEMATIC.....	2-V7
INSTALLATION DRAWING—ENGINE COMPARTMENT	2-V8
INSTALLATION DRAWING—PASSENGER COMPARTMENT	2-V9
SPEED CONTROL	
INSTALLATION DRAWING—ENGINE AND PASSENGER COMPARTMENT.....	2-V10



HOW TO USE THE VACUUM DIAGRAMS

IF IT IS A FORD CAR LINE VACUUM SYSTEM, THE TECHNICIAN WILL FIND A PAGE FOR THE TOTAL SCHEMATIC SYSTEM AS WELL AS A LISTING FOR A SCHEMATIC AND PICTORIAL OF EACH SUBSYSTEM ON EACH SECTION INDEX PAGE. IT IS RECOMMENDED THAT THE TECHNICIAN FIRST TURN TO THE TOTAL SYSTEMS SCHEMATIC TO DETERMINE IF THERE ARE ANY BRANCH SYSTEMS OPERATING FROM THE SAME SOURCE. THIS WILL ASSIST IN LOCATING SYSTEM TROUBLES. HE WILL THEN BE ABLE TO TURN TO A PAGE TO FIND DETAILED INFORMATION ON A PARTICULAR SYSTEM. IN TRACING VACUUM SYSTEMS, IT IS RECOMMENDED THAT A CIRCUIT BE TRACED FROM ITS CONTROL UNIT TO ITS SOURCE OF VACUUM, AND THEN FROM THE CONTROL UNIT TO THE OPERATING UNIT, NOTING POINTS OF POSSIBLE MALFUNCTION AND ACCESSIBILITY.

THE VACUUM SYMBOLS AND THEIR MEANINGS ARE NOTED ON EACH DIVIDER PAGE TO PROVIDE A CLEAR UNDERSTANDING OF THE DIAGRAMS.

VACUUM

CIRCUIT SYMBOLS

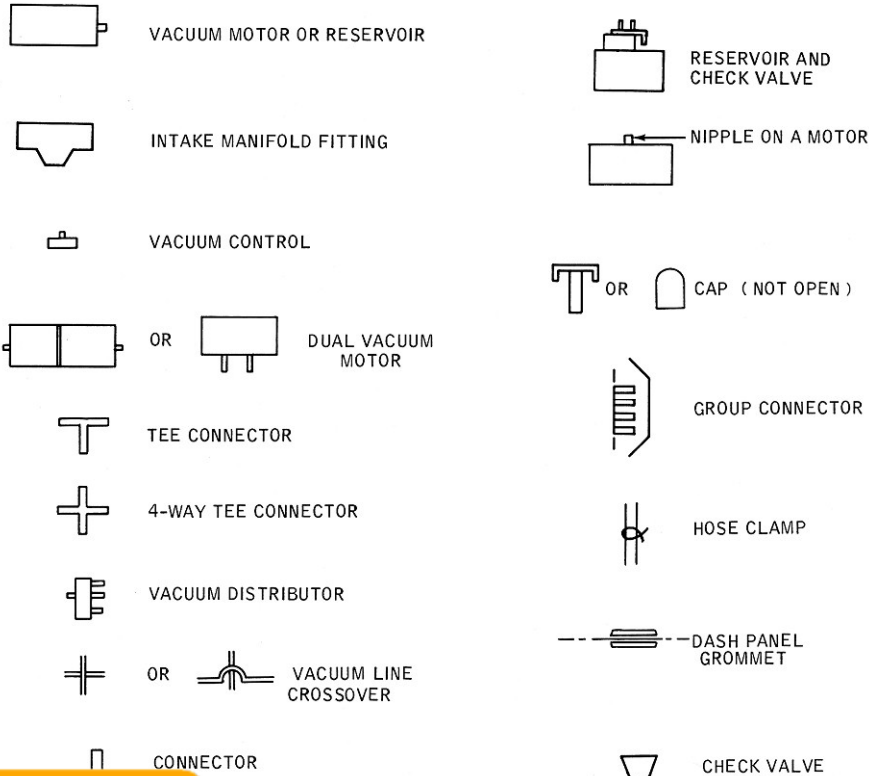

BUY IT NOW!

Click Here To Order



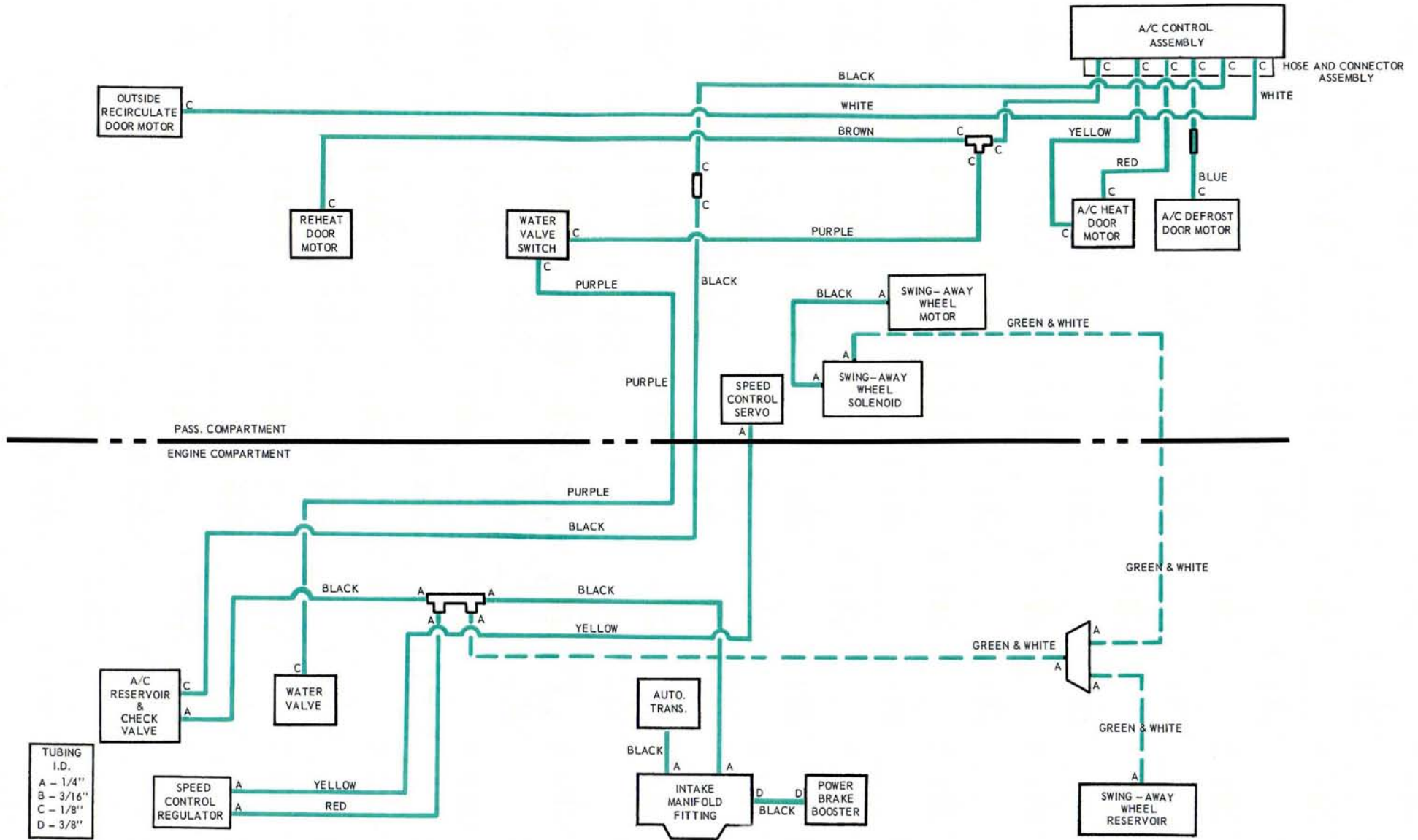

100% SATISFACTION GUARANTEED

BUY IT NOW!

Click Here To Order

1969 MUSTANG TOTAL VACUUM SCHEMATIC

1969 CAR SHOP MANUAL

Source Document
Ford Publication Form 7098-69-3

VOLUME THREE
ELECTRICAL

CHARGING, LIGHTING, HORNS, INSTRUMENTS, HEATING
VENTILATING, AIR CONDITIONING, SPEED CONTROL,
WINDSHIELD WIPERS and WASHERS, ACCESSORIES



BUY IT NOW!

Click Here To Order



FALCON

FAIRLANE

MUSTANG

FORD

THUNDERBIRD

MONTEGO

COUGAR

METEOR

MERCURY

LINCOLN
CONTINENTAL

CONTINENTAL
MARK III

1969 CAR SHOP MANUAL

VOLUME THREE ELECTRICAL

CHARGING, LIGHTING, HORNS, INSTRUMENTS, HEATING,
VENTILATING, AIR CONDITIONING, SPEED CONTROL,
WINDSHIELD WIPERS and WASHERS, ACCESSORIES

Service Publications
FIRST PRINTING—NOVEMBER, 1968
MICHIGAN

100% SATISFACTION GUARANTEED

BUY IT NOW!
Click Here To Order

GROUP INDEX

VEHICLE IDENTIFICATION

BRAKES

SUSPENSION, STEERING, WHEELS AND TIRES

VOLUME ONE

REAR AXLE

DRIVE SHAFT AND CLUTCH

MANUAL SHIFT TRANSMISSION

AUTOMATIC TRANSMISSION

ENGINE

IGNITION SYSTEM

VOLUME TWO

FUEL SYSTEM

COOLING SYSTEM

EXHAUST SYSTEM

STARTING SYSTEM

CHARGING SYSTEM

LIGHTS, INSTRUMENTS AND CONVENIENCE DEVICES

VENTILATING, HEATING AND ACCESSORIES

BODY, DOORS AND WINDOWS

VOLUME FOUR

TRIM, SEATS AND CONVERTIBLE TOP

VOLUME FIVE

MAINTENANCE

SPECIFICATIONS AND SPECIAL SERVICE TOOLS
AT END OF EACH GROUP

FOREWORD

The five volumes of this shop manual provide the Service Technician with complete information for the proper servicing of all the 1969 line of Ford Passenger Cars.

The information is grouped according to the type of work being performed, such as frequently performed adjustments and repairs, in-vehicle adjustments, major repair, etc. Specifications, maintenance information and recommended special tools are included.

The descriptions and specifications in this manual were in effect at the time this manual was approved for printing. Ford Motor Company reserves the right to discontinue models at any time, or change specifications or design, without notice and without incurring obligation.



SERVICE PUBLICATIONS



BUY IT NOW!
Click Here To Order



PayPal American Express Discover MasterCard VISA

GENERAL INFORMATION

Individual carline shop manuals have been combined in one Car Shop Manual divided into five volumes for 1969.

The 1969 Car Shop Manual has been organized into general Groups as in previous shop manuals. All Groups are listed in the Group index on the first page of each Volume. Groups not contained in a given Volume are listed with a solid gray background.

To locate the beginning page of any particular Group, first select the Volume containing that Group. Bend the manual until the black mark on the first page of the Group can be seen in line with the Group title on the first page of the Volume.

The first page of each Group lists the material contained in the Group under Part headings and also lists the beginning page of each Part.

On the beginning page of each Part, there is a Part index which lists in detail all information appearing in the Part, the page where the information is given, and the vehicles to which the information applies.

All pages carry a six-digit number which indicates the Group, Part and Page number.

For Example: Page 14-02-01 indicates
Group 14, Part 2, Page 1

Part Indexes will use only the Part and Page reference numbers.
For Example: Page 14-02-01 will appear in the Part Index as 02-01.

Each Part will start with Page 01.



<h1 style="margin: 0;">Charging System</h1>	<p>GROUP</p> <h1 style="margin: 0;">14</h1>
---	--

PART 14-1 PAGE
Autolite Alternators 14-01-01

PART 14-4 PAGE
Leece Neville Alternator
Regulators 14-04-01

PART 14-2
Autolite Alternator
Regulators 14-02-01

PART 14-5
Batteries 14-05-01

PART 14-3
Leece Neville Alternators 14-03-01

PART 14-6
Specifications 14-06-01

PART 14-1 Autolite Alternators

COMPONENT INDEX	MODEL APPLICATION											
	All Models	Ford	Mercury	Metear	Cougar	Fairlane	Falcon	Montego	Mustang	Lincoln-Continental	Thunderbird	Continental-Mark III
ADJUSTMENT—BELT, ALL MODELS	01-10											
DESCRIPTION AND OPERATION —ALL MODELS	01-02											
DISASSEMBLY AND OVERHAUL												
38-Ampere Alternator		N/A	N/A	N/A	N/A	N/A	01-11	N/A	N/A	N/A	N/A	N/A
42-Ampere Alternator		01-11	01-11	01-11	01-11	01-11	N/A	01-11	01-11	N/A	N/A	N/A
55-Ampere Alternator		01-11	01-11	01-11	01-11	01-11	01-11	01-11	01-11	01-11	N/A	N/A
55-Ampere Alternator With Integral Voltage Regulator		N/A	N/A	N/A	N/A	N/A	N/A	N/A	N/A	N/A	01-11	01-11
65-Ampere Alternator		01-13	01-13	01-13	N/A	01-13	N/A	N/A	N/A	N/A	01-13	01-13
REMOVAL AND INSTALLATION —ALL MODELS	01-10											
TESTING												
With Rotunda Alternator-Regulator Tester (ARE 20-22)	01-03											
With Rotunda Volt-Amp-Alternator- Regulator Tester (ARE 27-38)												
Diode Test	01-07											
Field Open or Short Circuit Test	01-03											
Stator Open or Grounded Circuit Tests	01-07											
Stator Neutral Voltage Test	01-03											
Output Test	01-03											

Page number indicates that the item is for the vehicle listed at the head of the column.
N/A indicates that the item is not applicable to the vehicle listed.

BUY IT NOW!

Click Here To Order

1 DESCRIPTION AND OPERATION

The alternator charging system is a negative (-) ground system, and consists of an alternator, a regulator, a charge indicator, a storage battery and associated wiring. Refer to Wiring Diagram Manual Form 7795-P-69 for schematics and locations of wiring harnesses.

ALTERNATOR

The alternator is belt driven from the engine. Energy is supplied from the alternator-regulator system to the rotating field of the alternator through two brushes to two slip rings.

The alternator produces power in the form of alternating current. The alternating current is rectified to direct current by six diodes for use in charging the battery and supplying power to the electrical system. The alternator is self current limiting.

Figs. 1; 2 and 3 show the alternator system schematics.

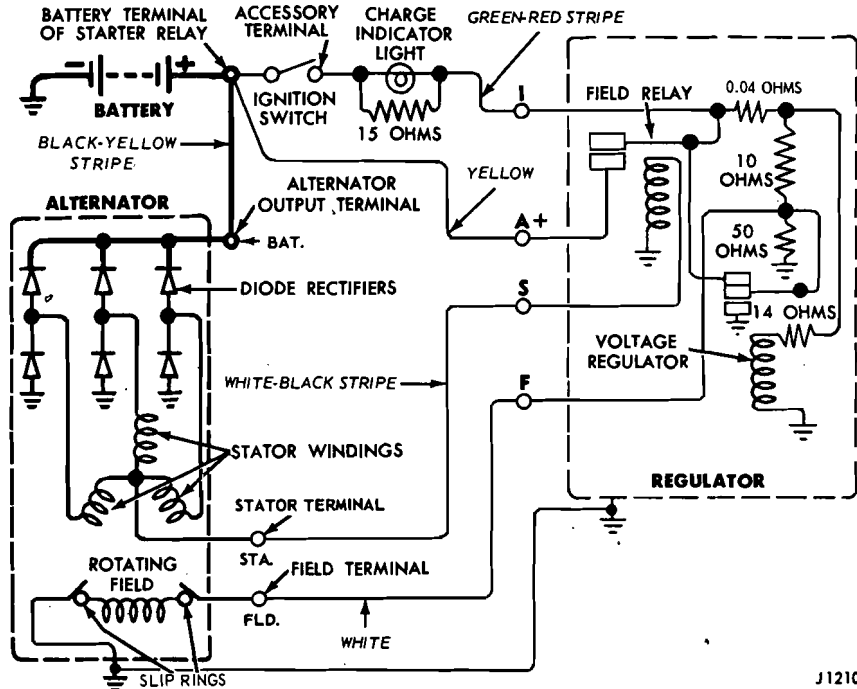

J1210-G

FIG. 1—Autolite Alternator System—Indicator Light

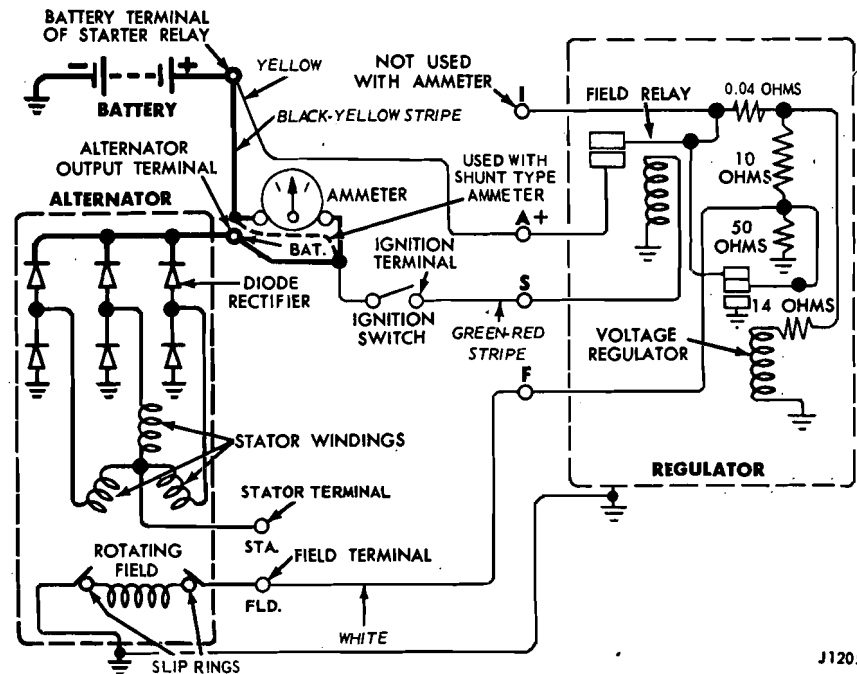

J1205-F

FIG. 2—Autolite Alternator System—Ammeter

100% SATISFACTION GUARANTEED

BUY IT NOW!

Click Here To Order

PayPal, American Express, Discover, MasterCard, VISA

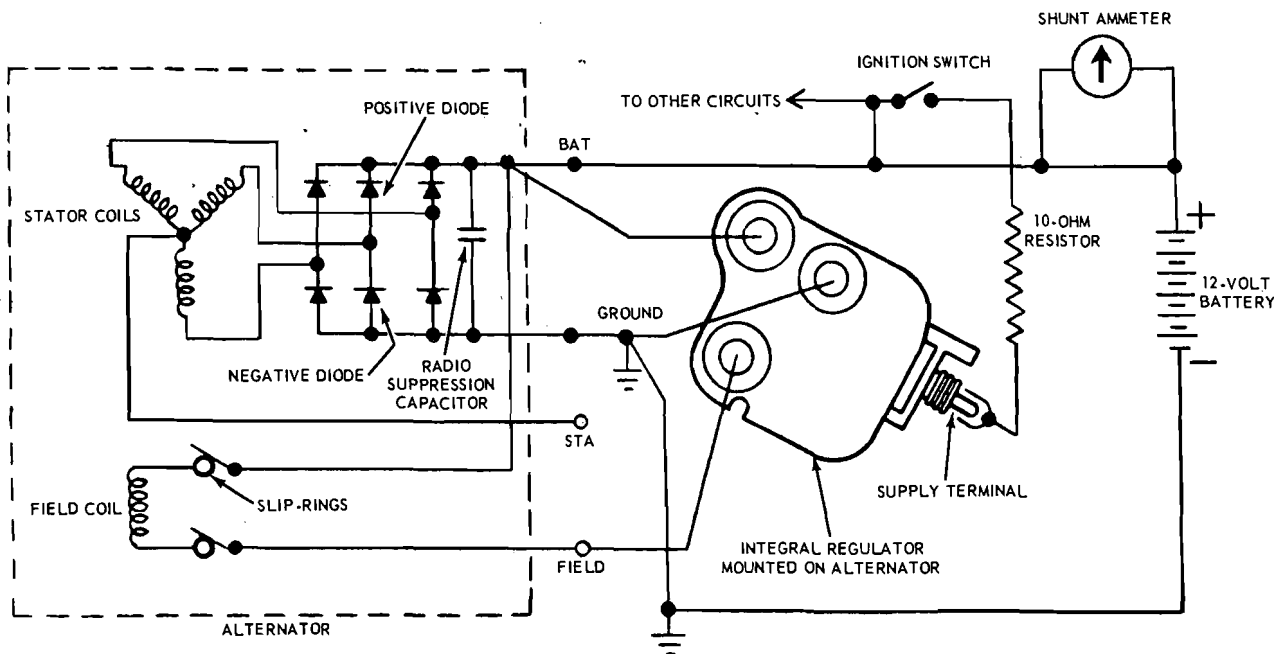

J1409-A

FIG. 3—Autolite Alternator System—With Integral Regulator

2 AUTOLITE ALTERNATOR TESTING

Refer to the Ford Car and Truck Diagnosis Manual for diagnosis of the Autolite alternator system.

Check the alternator drive belt and adjust it to specification (Part 13-6), before proceeding with any tests. Check and tighten all connectors at the starter relay and battery.

TESTS USING THE ROTUNDA ARE 20-22 ALTERNATOR REGULATOR TESTER

The general procedure is to connect the tester (Fig. 4), to the charging system, start the engine, make two tests, and then compare the pattern of lights that appear on the tester to each set of patterns shown on two charts (Figs. 5 and 6). Follow the instructions given with the ARE 20-22 tester. The ARE 20-22 tester cannot be used to test the alternator with the integral regulator.

Refer to Wiring Diagram Manual Form 7795-P-69 for schematics and locations of wiring harnesses. Use care when connecting any test equipment to the alternator system, as the alternator output terminal is connected to the battery at all times.

ALTERNATOR OUTPUT TEST ON ENGINE

When the alternator output test is conducted off the car, a test bench must be used. Follow the procedure given by the test bench equipment manufacturer. When the alternator is removed from the vehicle for this purpose always disconnect the battery ground cable as the alternator output connector is connected to the battery at all times.

To test the output of the alternator on the vehicle, proceed as follows:

1. Place the transmission in neutral or park and apply the parking brake. Make the connections and tester knob adjustments as shown in Figs. 7 or 8 Output Test. Be sure that the field rheostat knob is at the OFF position at the start of this test. Follow the instructions given with the ARE 27-38 tester.

AUTOLITE STATOR NEUTRAL VOLTAGE TEST—ON ENGINE

The Autolite alternator STA terminal is connected to the stator coil neutral; or center point of the alternator windings (see Figs. 1 and 2). The voltage generated at this point is used to close the field relay in the Autolite charge indicator light system except alternators with an integral regulator.

To test for the stator neutral voltage, disconnect the regulator connector plug from the regulator. Make the connections and tester knob adjustments as shown in Fig. 9. Follow the instructions given with the ARE 27-38 tester.

FIELD OPEN OR SHORT CIRCUIT TEST—ON BENCH

Alternators Without An Integral Regulator

Make the connection as shown in Fig. 7 Field Open or Short Circuit Test. The current draw, as indicated

100% SATISFACTION GUARANTEED

BUY IT NOW!

Click Here To Order

ke

PayPal American Express Cards DISCOVER NOVUS MasterCard VISA

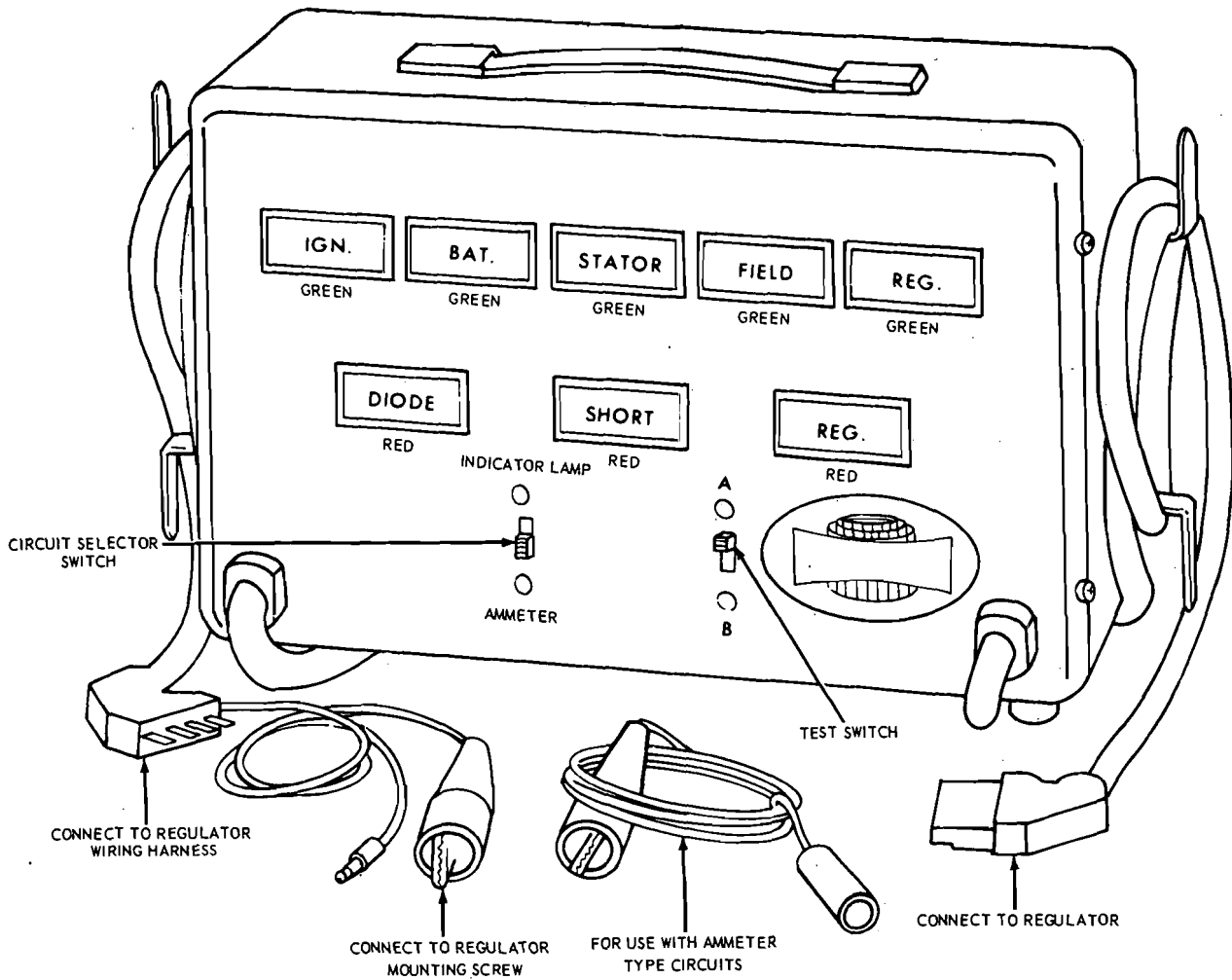

J 1398-A

FIG. 4—ARE 20-22 Tester

by the ammeter, should be to specifications (Part 13-6). If there is little or no current flow, the field or brushes have a high resistance or are open. A current flow considerably higher than that specified above, indicates shorted or grounded field turns or brush leads touching. If the test shows that the field is shorted or open and the field brush assembly or slip rings are not at fault, the entire rotor must be re-

ed. The alternator has output at low

Alternators With An Integral Regulator

Field Voltmeter Test

1. Turn the ignition switch to OFF Remove the wire from the regulator supply terminal.
2. Connect the ARE 27-38 tester, and make the tester knob adjustments as shown in Fig. 8, Field Voltmeter Test.
3. The voltmeter reading should be 12 volts. If there is no voltage reading, the field circuit is open or grounded.
4. If the voltmeter reading in Step 3 is more than one volt but less than battery voltage, there is an indicated partial ground in the alternator field

circuit. Perform the Alternator Field Ohmmeter Tests.

Field Ohmmeter Tests

1. Disconnect the battery ground cable.
2. Remove the regulator from the alternator.
3. Connect the ARE 27-42 ohmmeter leads as shown in Fig. 12, Ohmmeter Field Circuit Tests. Set the ohmmeter multiply-by knob at 1, and calibrate the ohmmeter as indicated inside the ohmmeter cover.
4. Three conditions are checked in these tests as shown in Fig. 12: A grounded field, a shorted field and an open field.

100% SATISFACTION GUARANTEED

BUY IT NOW!

Click Here To Order

PayPal, American Express, Discover, MasterCard, VISA

1965/72 FORD CAR

FINAL ISSUE

Master Parts and Accessories

Source Document
Ford Publication Form FP-7635-B

Form FP 7635-A & B

Supersedes All Previous Issues, Changes and Revisions



Official Licensed Product

5236

FINAL ISSUE



Model 1075

BUY IT NOW!

Click Here To Order

Copyright 1975 --

FORD MOTOR
COMPANY

-- DEARBORN, MICHIGAN

PayPal

Discover
Cards

Discover
Novus

MasterCard

VISA

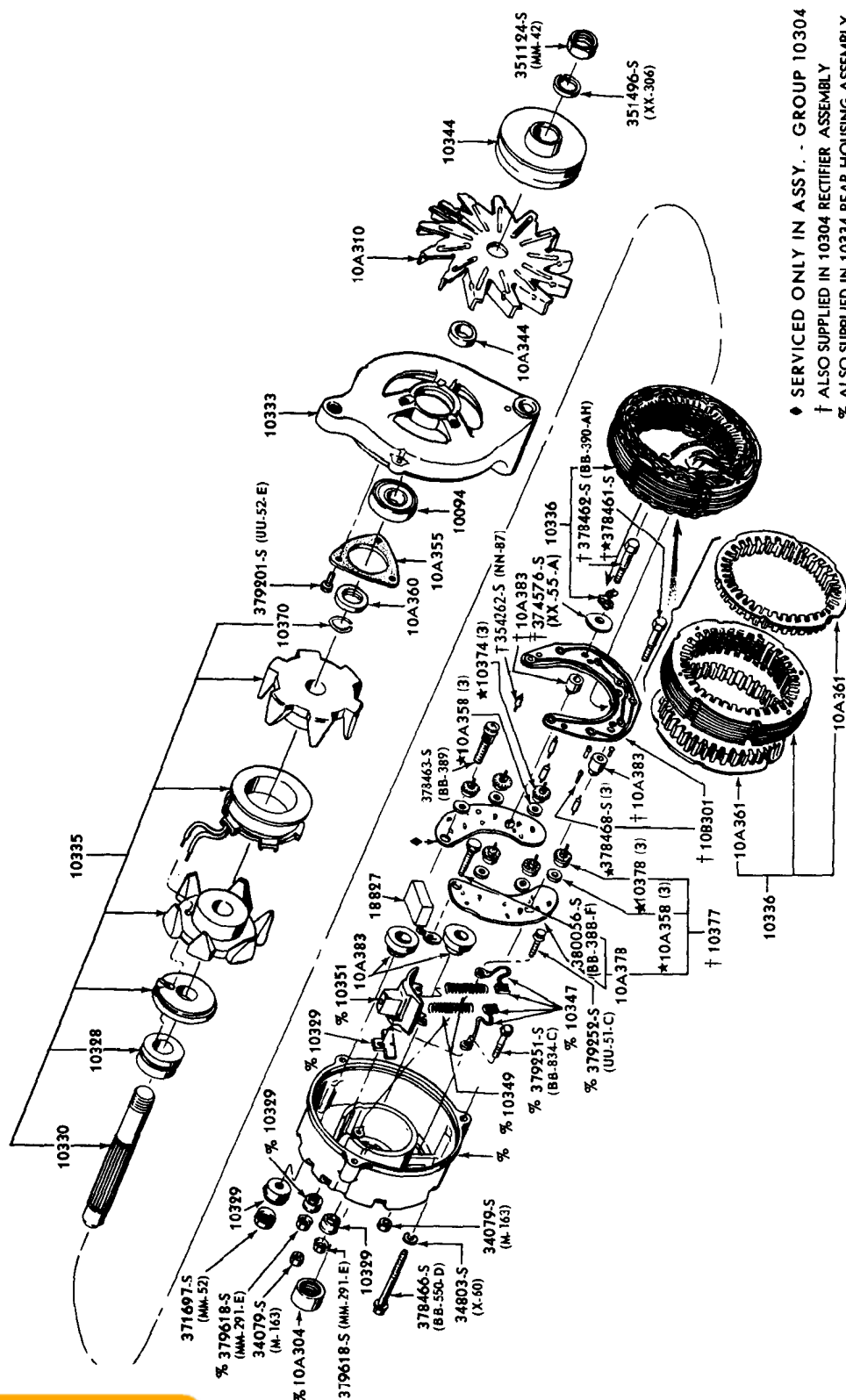

♦ SERVICED ONLY IN ASSY. - GROUP 10304
 † ALSO SUPPLIED IN 10304 RECTIFIER ASSEMBLY
 % ALSO SUPPLIED IN 10334 REAR HOUSING ASSEMBLY

P-4508

GENERATOR (FORD 15 VOLT - 38,42,45,55,60,61 AMP.)
 1965/72

100% SATISFACTION GUARANTEED

BUY IT NOW!

Click Here To Order



READY REFERENCE

13001

HOW TO READ WIRING DIAGRAMS



VOL 68 S7 L2A

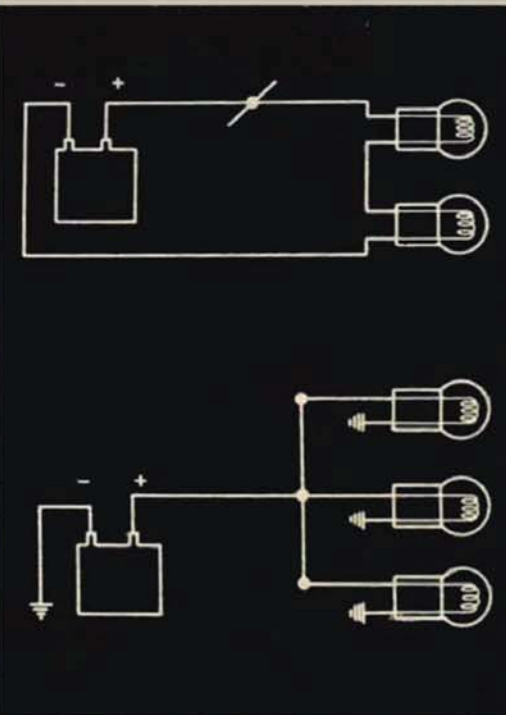

BUY IT NOW!

Click Here To Order



HOW TO READ WIRING DIAGRAMS

COURSE 13001 • VOL. 68 S7 L2A

TABLE OF CONTENTS

Page

INTRODUCTION

A LOGICAL APPROACH TO ELECTRICAL DIAGNOSIS	1
Like reading a road map	2
How wires are numbered and color-coded	2
CIRCUIT – A COMPLETE ELECTRICAL PATH BETWEEN TWO POINTS	5
2-wire circuit	6
Single wire circuit	6
Ground connections	7
OPEN CIRCUITS	8
Shorts	9
Grounded circuit	9
Series and parallel open circuits	10
BREAKS IN PARALLEL CIRCUITS	11
Common points	14
Splices	15
Fuses and circuit breakers	17
Quick disconnects	18
Male and female elements	20
Types of quick disconnects	22
HINTS FOR TRACING WIRES THROUGH A DRAWING	23
Curve directions	23
Common points	24
Switches	25
Relays	26
Assemblies	28
Locating the assembly	29
Finding the wire	30
SUMMARY	31

100% SATISFACTION GUARANTEED

BUY IT NOW!

Click Here To Order

PayPal American Express Discover MasterCard VISA

The descriptions, testing procedures, and specifications in this handbook were approved for printing. Ford Motor Company reserves the right to change specifications without notice and without incurring

NATIONAL SERVICE OFFICE
FORD DIVISION



FIRST PRINTING – JANUARY, 1968

© 1968 FORD MOTOR COMPANY
DEARBORN, MICHIGAN

INTRODUCTION

The Why and Wherefore of Wiring Diagrams

To the uninformed, a wiring diagram — or a wiring assembly — looks like it might take a genius to figure out.

Not so — as you'll find out when you get better acquainted with these subjects.

There're as understandable and logical as a road map and road markers, when you're finding your way on a cross-country drive.

The ability to read a wiring diagram and relate it to a vehicle's wiring system is, of course, an essential part of a modern service technician's skill. And it's growing in relative importance, too, due to owner's increasing demands for the comforts and conveniences supplied by electrically-operated options and accessories. This opens up greater opportunities, for the forward-looking technician.

The Purpose of this Booklet . . .

. . . is to acquaint you with the systems by which electrical circuits are traced on vehicles. Specifically, it is designed to help you acquire the ability to make your own power checks, quickly and accurately.

Scope of the Booklet

Basically, this is a printed version of the film, "How to Read a Wiring Diagram." It is in no sense a manual of the shop methods by which electrical repairs are made.

It *can* be a helpful guide that can introduce you to the principles of wiring diagrams and vehicle wiring. As you gain experience in reading wiring diagrams, you'll accumulate your own know-how in this important skill. When it becomes "second nature" to you, these pages will have served their purpose — and yours.



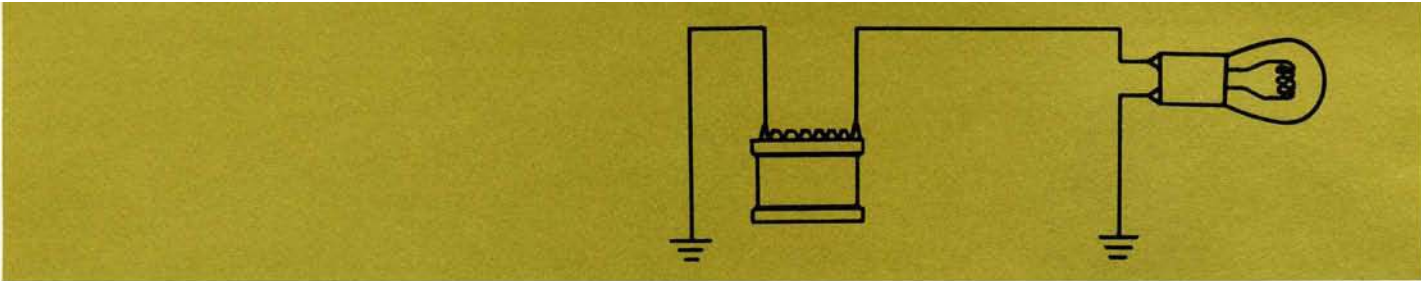

To show how to read wiring diagrams — and to explain how they can be used to help you troubleshoot problems in the electrical system — is what this booklet is all about. Obviously, these are important subjects.

A LOGICAL APPROACH TO ELECTRICAL DIAGNOSIS



If a customer comes in because his headlights aren't working, you can't just make a snap decision. That's not the *professional way*.



When you go to a doctor, for example, he tries to find out what's *really* wrong with you. He looks beyond the aches and pains you feel, to see what's *causing* the trouble. We call this, *diagnosis*.

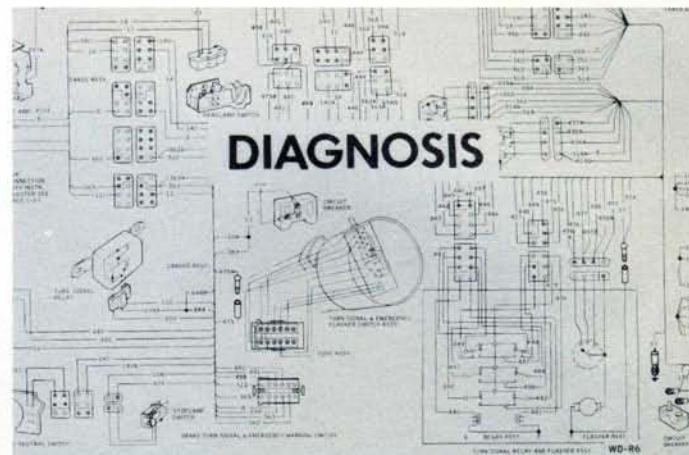

Troubleshooting an electrical system calls for diagnosis, too — *Your* diagnosis. *You're* the doctor. You must find out what's causing the trouble, and fix it.



BUY IT NOW!

Click Here To Order

unit may be the way may not. Snap professional.



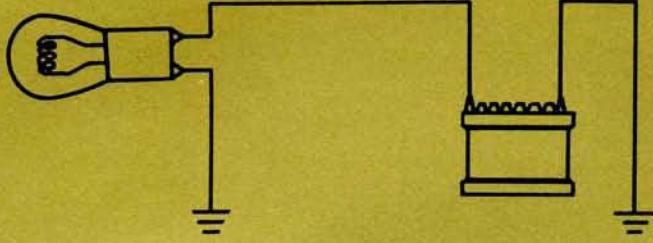

LOGICAL APPROACH

The easiest way is to begin with a *logical approach* — you check things out. You find out what parts of the electrical system are still working okay. You narrow it down to one part — one wire — one switch.

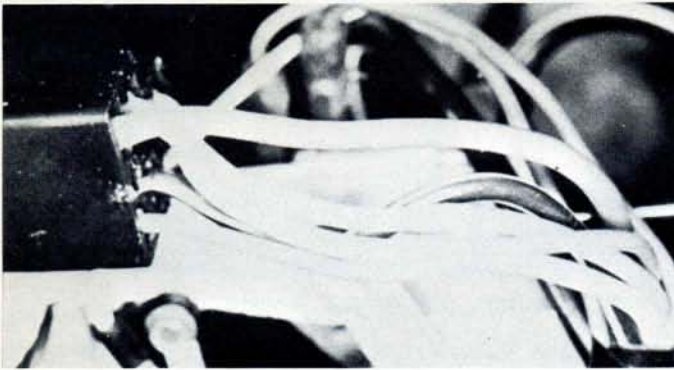

Sure, you may feel a little confused when you face a jumble of wires for the first time. But there's a way to make sense out of this. There *is* a logical approach.

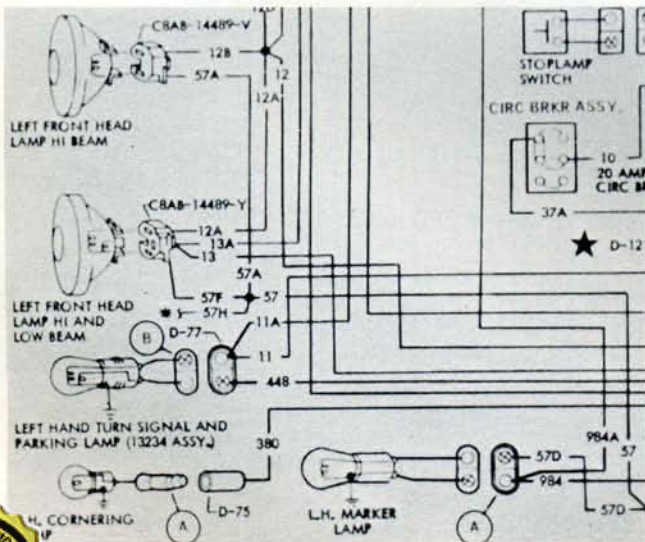

LIKE READING A ROAD MAP

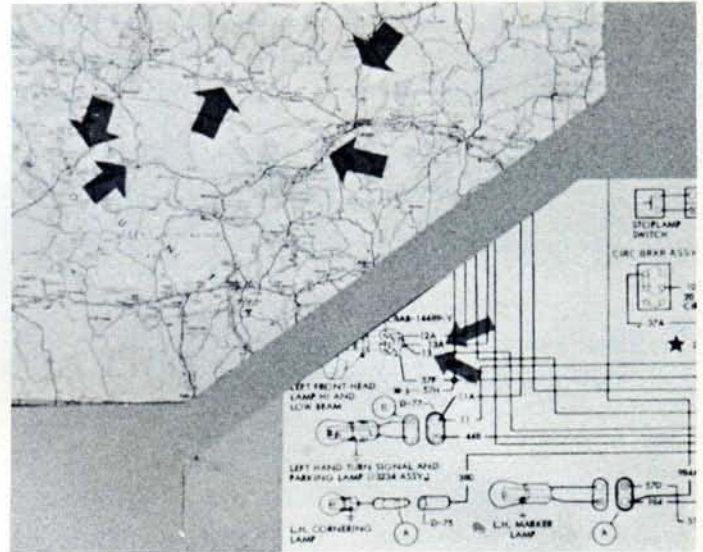

Reading a wiring diagram is something like reading a road map. The map shows routes that connect one place with another . . . and a diagram shows routes, too. The lines represent actual wires, and these wires are identified by numbers . . . much like highways are identified by number.

HOW WIRES ARE NUMBERED AND COLOR-CODED



When you want to locate a specific highway, you check the number on the map with a number on a highway sign. It's almost that easy with wires and wiring numbers.



BUY IT NOW!

Click Here To Order

hat shows all elec-
trophics, connections,
eed to know.

PayPal

Discover
Cards

DISCOVER
WORLDWIDE

MasterCard

VISA