

Colorized

Mustang Wiring & Vacuum Diagrams

(with Electrical Illustrations)

Free Bonus!
30-Minute Video
Ford Training
Course 13001, Vol 68 S7
"How to Read Wiring
Diagrams"
Included!

A consolidated collection of original Ford electrical & vacuum diagrams with illustrations

Color diagrams for:

- Air Conditioner
- Convenience Control Group
- Exterior Lighting and Turn Signals
- Heater-Defroster
- Horns
- Ignition, Starting and Charging
- Instrument Panel
- Interior Lighting
- Pre-Wired Instrument Cluster
- Radio, Stereo and Speakers
- Speed Control

...and much more!!

Licensed and approved
by the Ford Motor Company



BUY IT NOW!

Click Here To Order

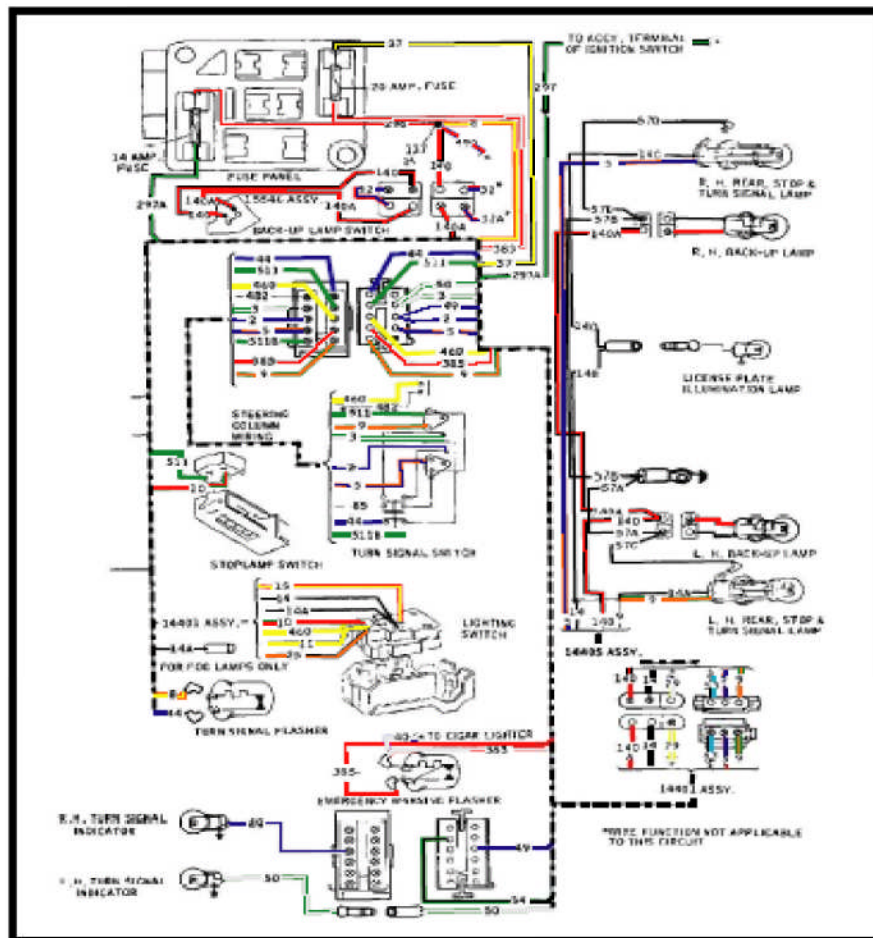

Example of colorized diagrams

Copyright © 2008, Forel Publishing Company, LLC, Woodbridge, Virginia

All Rights Reserved. No part of this book may be used or reproduced in any manner whatsoever without written permission of Forel Publishing Company, LLC. For information write to Forel Publishing Company, LLC, 3999 Peregrine Ridge Ct., Woodbridge, VA 22192

1968 Ford Mustang Wiring and Vacuum Diagrams
(Extracted from Form 7760-68, Form FD-7795P-68, FD-7943-68, FP-7635B, and FD-7943-G)
EAN: 978-1-60371-027-5
ISBN: 1-60371-027-2

Forel Publishing Company, LLC
3999 Peregrine Ridge Ct.
Woodbridge, VA 22192
Email address: webmaster@ForelPublishing.com
Website: <http://www.ForelPublishing.com>



This publication contains material that is reproduced and distributed under a license from Ford Motor Company. No further reproduction or distribution of the Ford Motor Company material is allowed without the express written permission of Ford Motor Company.

Note from the Editor

This product was compiled using several original Ford Motor Company publications. In some cases, there are slight differences between publications, so it is important to compare between diagrams, schematics, or illustrations. The contents of this product were extracted from: *1968 Cougar, Fairlane, Falcon, Mercury and Mustang Shop Manual* (Form 7760-68, March 1968), *1965/1972 Ford Car Master Parts and Accessory Catalog* (Form FP-7635B, May 1975, and *1968 Wiring Diagrams* (Form FD-7795P-67 & FD-7943-67) and *How to Read Wiring Diagrams* (FD-7943-G).

Disclaimer

Although every effort was made to ensure the accuracy of this book, no representations or warranties of any kind are made concerning the accuracy, completeness or suitability of the information, either expressed or implied. As a result, the information contained within this book should be used as general information only. The author and Forel Publishing Company, LLC shall have neither liability nor responsibility to any person or entity with respect to any loss or damage caused, or alleged to be caused, directly or indirectly by the information contained in this book. Further, the publisher and author are not engaged in rendering legal or other professional services. If legal, mechanical, electrical, or other expert assistance is required, the services of a competent professional should be sought.

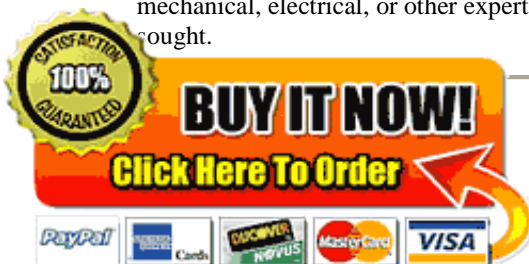



ATTENTION

Please Read This



It is important to note that differences exist between similar or like wiring diagrams even though they are original Ford publications. It is for this reason there may be multiple versions of what appears to be the same wiring diagram. If your vehicle has a color coded wire that does not match a diagram you should consult the other diagrams contained in the manual for a possible match.

Example of differences

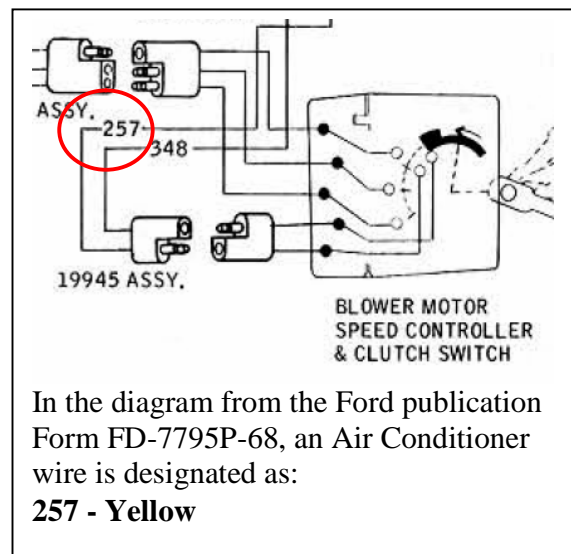
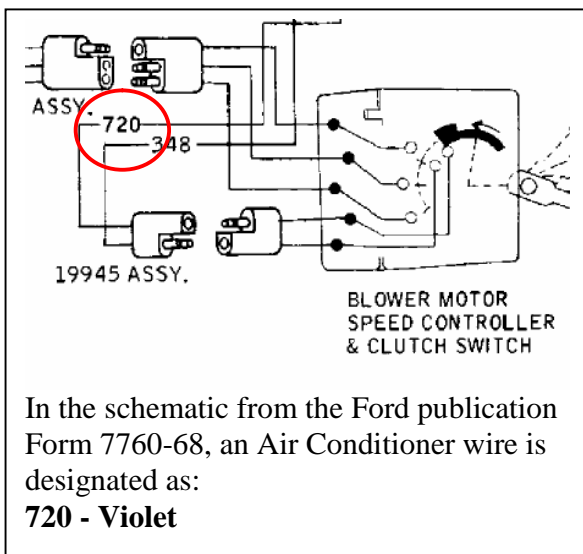

The color coded wiring diagrams are provided for illustration purposes only. Only the wire number should be used for the identification of the wire itself. The color coding of the wires in the product may not match the actual colors of the wires in the vehicle. In some cases, the colors have been altered to provide a visual contrast (i.e. the color white has been shaded to make it more visible). As stated in the paragraph above, there are some variation and/or differences between the original Ford wiring diagrams. If your vehicle has a color coded wire that does not match a diagram you should consult the other diagrams contained in the manual for a possible match.

Disclaimer: Although every effort was made to ensure the accuracy of this book, no representations or warranties of any kind are made concerning the accuracy, completeness or suitability of the information, either expressed or implied. As a result, the information contained within this book should be used as general information only. The author and Forel Publishing Company, LLC shall have neither liability nor responsibility to any person or entity with respect to any loss or damage caused, or alleged to be caused, directly or indirectly by the information contained in this book. Further, the publisher and author are not engaged in rendering legal or other professional services. If legal, mechanical, electrical, or other expert assistance is required, the services of a competent professional should be sought.

100% SATISFACTION GUARANTEED

BUY IT NOW!

Click Here To Order

PayPal American Express Discover MasterCard VISA

1968 Color Wiring Codes

Number	Wire Description	Source
2	WHITE-BLUE STRIPE	Form 7760-68*
2A	WHITE-BLUE STRIPE	FD-7795P-68
3	GREEN-WHITE STRIPE	Form 7760-68*
3A	GREEN-WHITE STRIPE	Form 7760-68
5	ORANGE-BLUE STRIPE	Form 7760-68
8	ORANGE-YELLOW STRIPE	Form 7760-68
9	GREEN-ORANGE STRIPE	Form 7760-68
10	GREEN-RED STRIPE	Form 7760-68*
11	BLACK-YELLOW STRIPE	FD-7795P-68
11A	BLACK-YELLOW STRIPE	FD-7795P-68
12	GREEN-BLACK STRIPE	FD-7795P-68
12A	GREEN-BLACK STRIPE	FD-7795P-68
13	RED-BLACK STRIPE	FD-7795P-68
13A	RED-BLACK STRIPE	FD-7795P-68
14	BLACK	FD-7795P-68
14A	BLACK	FD-7795P-68
14B	BLACK	FD-7795P-68
14C	BLACK	FD-7795P-68
15	RED-YELLOW STRIPE	FD-7795P-68
16	RED-GREEN STRIPE	Form 7760-68*
16A	RED-GREEN STRIPE	Form 7760-68*
16A	PINK	Form 7760-68*
16B	RED-GREEN STRIPE	Form 7760-68*
19	BLUE-RED STRIPE	Form 7760-68*
19A	BLUE-RED STRIPE	Form 7760-68*
19B	BLUE-RED STRIPE	Form 7760-68*
19C	BLUE-RED STRIPE	Form 7760-68*
19D	BLUE-RED STRIPE	Form 7760-68*
19E	BLUE-RED STRIPE	Form 7760-68*
19F	BLUE-RED STRIPE	Form 7760-68*
19G	BLUE-RED STRIPE	Form 7760-68*
21	YELLOW	Form 7760-68*
22	BLUE-BLACK STRIPE	Form 7760-68*
25	BLACK-ORANGE STRIPE	Form 7760-68*
26	BLACK-RED STRIPE	Form 7760-68*
26	BLACK	Form 7760-68*
26A	BLACK	Form 7760-68*
28	BLACK	Form 7760-68*
28A	BLACK	Form 7760-68*
	YELLOW-WHITE STRIPE	Form 7760-68*
		Form 7760-68*

Number	Wire Description	Source
31	WHITE-RED STRIPE	Form 7760-68*
31	WHITE-BLUE STRIPE	Form 7760-68*
32	RED-BLUE STRIPE	Form 7760-68*
32A	RED-BLUE STRIPE	Form 7760-68*
34	GREEN-BLACK STRIPE	Form 7760-68*
37	BLACK-YELLOW STRIPE	Form 7760-68*
37A	BLACK-YELLOW STRIPE	Form 7760-68*
37B	BLACK-YELLOW STRIPE	Form 7760-68*
38	BLACK	Form 7760-68*
38A	BLACK	Form 7760-68*
39	RED-WHITE STRIPE	Form 7760-68*
40	BLUE-WHITE STRIPE	Form 7760-68*
44	BLUE	FD-7795P-68
47	BLACK	Form 7760-68*
49	WHITE-BLUE STRIPE	Form 7760-68*
50	GREEN-WHITE STRIPE	Form 7760-68*
53	BLACK-BLUE STRIPE	Form 7760-68*
53A	BLACK-BLUE STRIPE	Form 7760-68*
53B	BLACK-BLUE STRIPE	Form 7760-68*
53C	BLACK-BLUE STRIPE	Form 7760-68*
53D	BLACK-BLUE STRIPE	Form 7760-68*
53E	BLACK-BLUE STRIPE	Form 7760-68*
54	GREEN-YELLOW STRIPE	Form 7760-68*
54A	GREEN-YELLOW STRIPE	Form 7760-68*
54B	GREEN-YELLOW STRIPE	Form 7760-68*
54C	GREEN-YELLOW STRIPE	Form 7760-68*
54D	GREEN-YELLOW STRIPE	Form 7760-68*
54E	GREEN-YELLOW STRIPE	Form 7760-68*
56	BLUE	Form 7760-68*
57	BLACK	Form 7760-68*
57A	BLACK	Form 7760-68*
57B	BLACK	FD-7795P-68
57C	BLACK	FD-7795P-68
57D	BLACK	FD-7795P-68
58	WHITE	Form 7760-68*
58A	WHITE	Form 7760-68*
60A	BLACK-WHITE STRIPE	Form 7760-68*
60B	BLACK-WHITE STRIPE	Form 7760-68*
63	RED	Form 7760-68*
63A	RED	Form 7760-68*
87	GREEN-ORANGE STRIPE	Form 7760-68*

100% SATISFACTION GUARANTEED

BUY IT NOW!

Click Here To Order

PayPal American Express Discover MasterCard VISA

Number	Wire Description	Source
122	YELLOW	Form 7760-68*
123	RED	Form 7760-68*
137	YELLOW-BLACK STRIPE	Form 7760-68*
140	BLACK-RED STRIPE	Form 7760-68*
140A	BLACK-RED STRIPE	Form 7760-68*
152	YELLOW	Form 7760-68*
152A	YELLOW	Form 7760-68*
162	GREEN-RED STRIPE	Form 7760-68*
163	RED-GREEN STRIPE	Form 7760-68*
175	BLACK	Form 7760-68*
181	BROWN	Form 7760-68*
186	BROWN	Form 7760-68*
215	YELLOW-BLACK STRIPE	Form 7760-68*
257	YELLOW	Form 7760-68*
260	RED-BLACK STRIPE	Form 7760-68*
260A	VIOLET	Form 7760-68*
262	BROWN	Form 7760-68*
268	RED	Form 7760-68*
269	BLUE	Form 7760-68*
270	BLACK-YELLOW STRIPE	Form 7760-68*
296	RED	Form 7760-68*
297	BLACK-GREEN STRIPE	Form 7760-68*
297	BLUE-GREEN STRIPE	Form 7760-68*
297A	BLACK-GREEN STRIPE	Form 7760-68*
297A	BLUE-GREEN STRIPE	Form 7760-68*
348	GREEN	Form 7760-68
365	BLUE-RED STRIPE	Form 7760-68*
365A	BLUE-RED STRIPE	Form 7760-68*
365B	BLUE-RED STRIPE	Form 7760-68*
365C	BLUE-RED STRIPE	Form 7760-68*
366	RED	Form 7760-68*
367	GREEN-WHITE STRIPE	Form 7760-68*
375	UNKNOWN	Form 7760-68*
383	RED-WHITE STRIPE	Form 7760-68*
385	WHITE-RED STRIPE	Form 7760-68*
450	GREEN	Form 7760-68*
450A	GREEN	Form 7760-68*
460	YELLOW	Form 7760-68*
482	BLUE-YELLOW STRIPE	Form 7760-68*
	UNKNOWN	Form 7760-68*
		Form 7760-68*

Number	Wire Description	Source
482A	BLUE-YELLOW STRIPE	Form 7760-68*
485	BROWN	Form 7760-68*
490	BLUE-RED STRIPE	Form 7760-68*
490	BLACK-RED STRIPE	Form 7760-68*
511	GREEN	Form 7760-68*
520	VIOLET	Form 7760-68*
591	BLACK-ORANGE STRIPE	Form 7760-68*
592	BLUE-WHITE STRIPE	Form 7760-68*
615A	BLACK	Form 7760-68*
627	BLACK-VIOLET STRIPE	Form 7760-68*
627A	BLACK-VIOLET STRIPE	Form 7760-68*
640	RED-YELLOW STRIPE	Form 7760-68*
654	VIOLET	Form 7760-68*
654	YELLOW	Form 7760-68*
655	YELLOW	Form 7760-68*
655	RED	Form 7760-68*
763	ORANGE-WHITE STRIPE	Form 7760-68*
763	ORANGE	Form 7760-68*
806	WHITE	Form 7760-68*
807	ORANGE	Form 7760-68*
904	GREEN-RED STRIPE	Form 7760-68*
913	YELLOW	Form 7760-68*
914	GREEN	Form 7760-68*
923	VIOLET	Form 7760-68*
925	WHITE	Form 7760-68*
931	BLACK	Form 7760-68*
977	RED	Form 7760-68*
984	BROWN	Form 7760-68*
984A	BROWN	FD-7795P-68
997	UNKNOWN	Form 7760-68

* Indicates that wire colors are the same in both Form 7760-68 and FD-7795P-68.

Note – wire color codes highlighted in **RED** designate a difference either between the original Ford wiring publications or within the same publication. Those highlighted have the same wire number but have different color codes.

100% SATISFACTION GUARANTEED

BUY IT NOW!

Click Here To Order





















PayPal American Express Cards Discover NOVUS MasterCard VISA













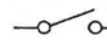

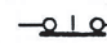
100% GUARANTEED
BUY IT NOW!
 Click Here To Order

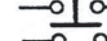
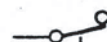
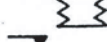
WIRE SYMBOLS

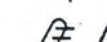







-  HEATER
-  CIRCUIT BREAKER
-  FUSE
-  RESISTOR OR RESISTANCE WIRE
-  DIODE
-  CAPACITOR OR CONDENSER
-  THERMOSTAT (VARIABLE RESISTANCE)
-  THERMISTOR
-  SPARK PLUG
-  GROUND
-  BATTERY
-  MAINTAINED CONTACT
-  MOMENTARY CONTACT
-  SPLICE, WELD OR SOLDER POINT
-  SPLICED WIRES
-  CROSSOVER WIRE (NO CONNECTION)
-  JUNCTION BLOCK
-  HORN
-  BUSS BAR
-  BUS BAR & SPLICE

SWITCHES



-  N.O. (SPST)
-  N.O. (SPST)
-  N.O. (DPST)
-  PUSH TYPE N.C.
-  PUSH TYPE N.O.
-  PUSH TYPE N.O. MULTIPLE POLE
-  PRESSURE OR VACUUM OPERATED N.C.
-  (SPDT) CENTER OFF
-  ROTARY SWITCH
-  MERCURY SWITCH
-  THERMAL SWITCH INTERNAL HEATER N.C.
-  THERMAL SWITCH INTERNAL HEATER N.C.
-  THERMAL SWITCH EXTERNAL HEATER N.C.

N.O. - NORMALLY OPEN
 N.C. - NORMALLY CLOSED
 S.P.S.T. - SINGLE POLE, SINGLE THROW
 D.P.S.T. - DOUBLE POLE, SINGLE THROW
 S.P.D.T. - SINGLE POLE, DOUBLE THROW
 D.P.D.T. - DOUBLE POLE, DOUBLE THROW

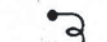

RELAYS

-  N.O. (SPST)
-  N.C. (SPST)
-  SPDT
-  N.O. DPST
-  N.C. DPST
-  SOLENOID
-  COIL AIR CORE
-  IGNITION COIL





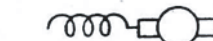





LAMPS

-  SINGLE FILAMENT
-  DOUBLE FILAMENT

MOTORS

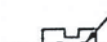
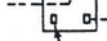
-  BASIC SERIES
-  SPLIT SERIES
-  PERMANENT MAGNET

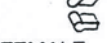
CONNECTORS

-  FEMALE CONNECTOR
-  OFF SET
-  MALE CONNECTOR
-  CONNECTOR NOT USED
-  BULLET CONNECTOR
-  SPADE NOT USED
-  FEMALE SPADE CONNECTOR
-  MALE SPADE CONNECTOR
-  MULTIPLE PLUG
-  COVER FOR CONNECTOR PINS
-  IGNITION SWITCH

- AND/OR * WIRE FUNCTION NOT APPLICABLE TO THIS CIRCUIT
 (14), (16) ETC. ALL NUMBERS IN **A**, **B**, ETC. ALL LETTERS CIRCLED INDICATE CONNECTION LOCATION.
 ★ TO POWER SOURCE

1968 MUSTANG ELECTRICAL DRAWINGS

INDEX

AIR CONDITIONER.....	E11	INSTRUMENT CLUSTER.....	E2 & E3
CHARGING.....	E4 & E5	INSTRUMENT PANEL.....	E2
CIGAR LIGHTER.....	E8	INTERIOR LIGHTS.....	E8
CLOCK.....	E3	NEUTRAL SWITCH.....	E20
CONVENIENCE SYSTEMS.....	E19	RADIO.....	E14 & E15
CONVERTIBLE TOP.....	E13	SPEED CONTROL.....	E16 & E17
DEFOGGER.....	E12	STARTING.....	E4 & E5
EXTERIOR LIGHTS.....	E6 & E7	STEREO TAPE.....	E14 & E15
GAUGES.....	E3	TILT WHEEL.....	E18
HEATER AND DEFROSTER.....	E10	TURN SIGNALS.....	E6 & E7
HORNS.....	E6	WINDSHIELD WIPERS AND WASHERS.....	E9
IGNITION.....	E4 & E5		



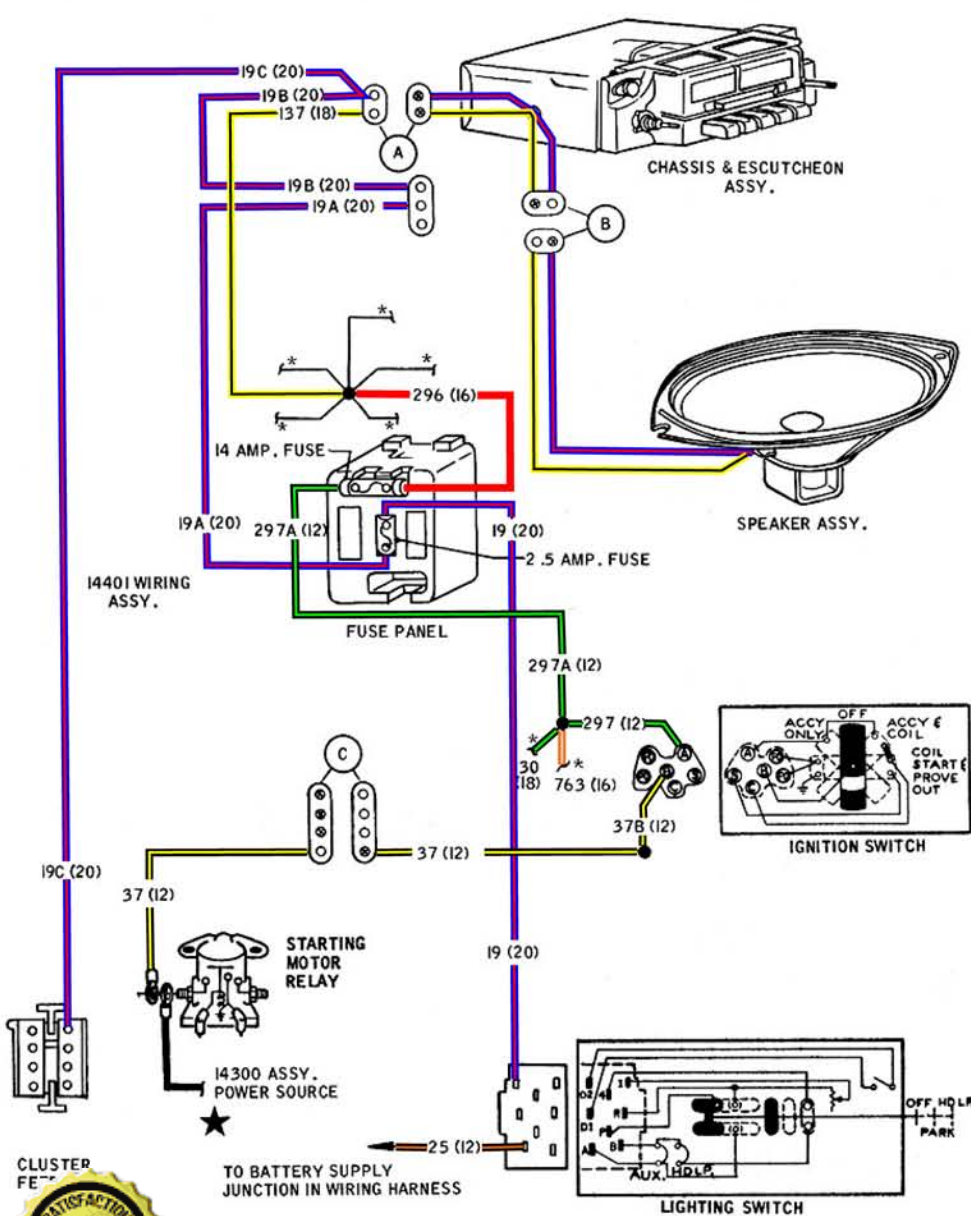

(AM) & (AM-FM)

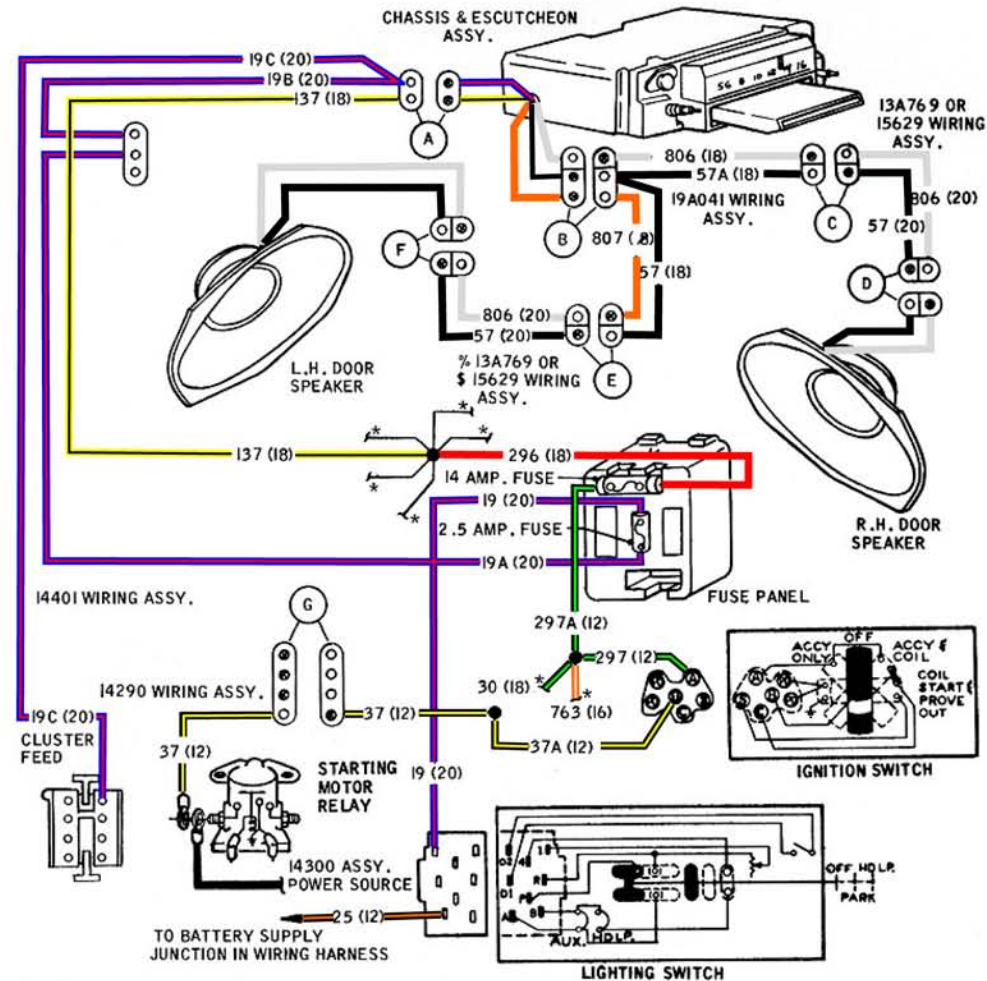

RADIO STEREO TAPE (AM)

NOTE:
 DETAIL & ITEM REFERENCE SHOWN ON PRODUCT DRAWING
 ALL NUMBERS IN PARENTHESIS () INDICATE WIRE GAUGE
 (A) ALL LETTERS CIRCLED AS SHOWN INDICATE CONNECTORS
 * WIRE FUNCTION NOT APPLICABLE TO THIS CIRCUIT.
 UNLESS OTHERWISE SPECIFIED ALL CONNECTORS ARE BLACK

WIRING COLOR CODE

WIRING	COLOR	CODE													
19C	19B	19A	19	25	57A	296	297	30	297A	490	763	806	807	§	%

100% SATISFACTION GUARANTEED

BUY IT NOW!

[Click Here To Order](#)

PayPal, American Express, Discover, MasterCard, VISA

MUSTANG AM AND AM-FM RADIOS AND STEREO TAPE

1968

COUGAR

FAIRLANE

FALCON

MONTEGO

MUSTANG

Source Document
Ford Publication Form 7760-68

SHOP MANUAL



BUY IT NOW!

Click Here To Order



PayPal

Discover
Cards

DISCOVER
NEWUS

MasterCard

VISA

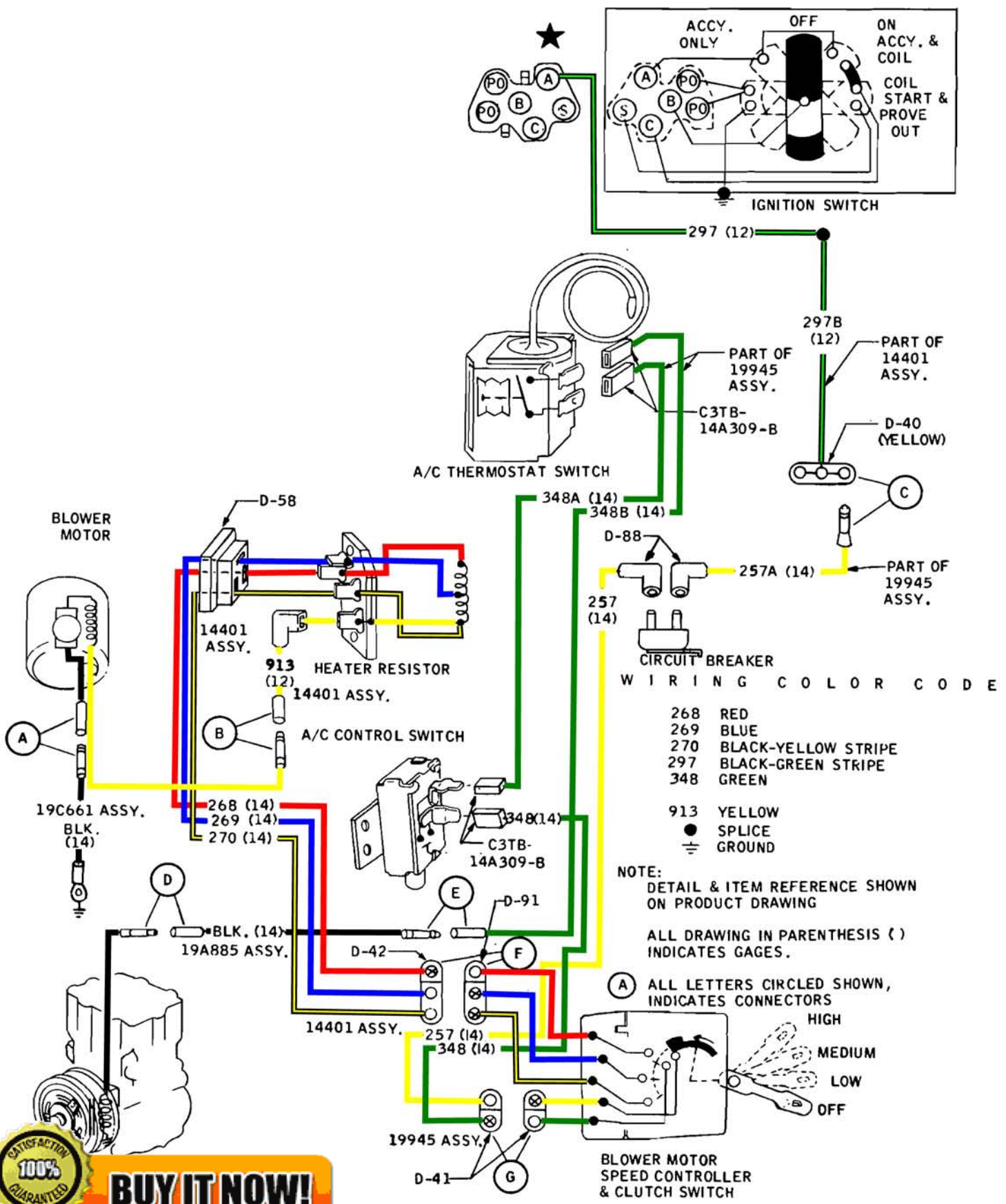

100% SATISFACTION GUARANTEED

BUY IT NOW!

Click Here To Order

Conditioner - Mustang and Cougar

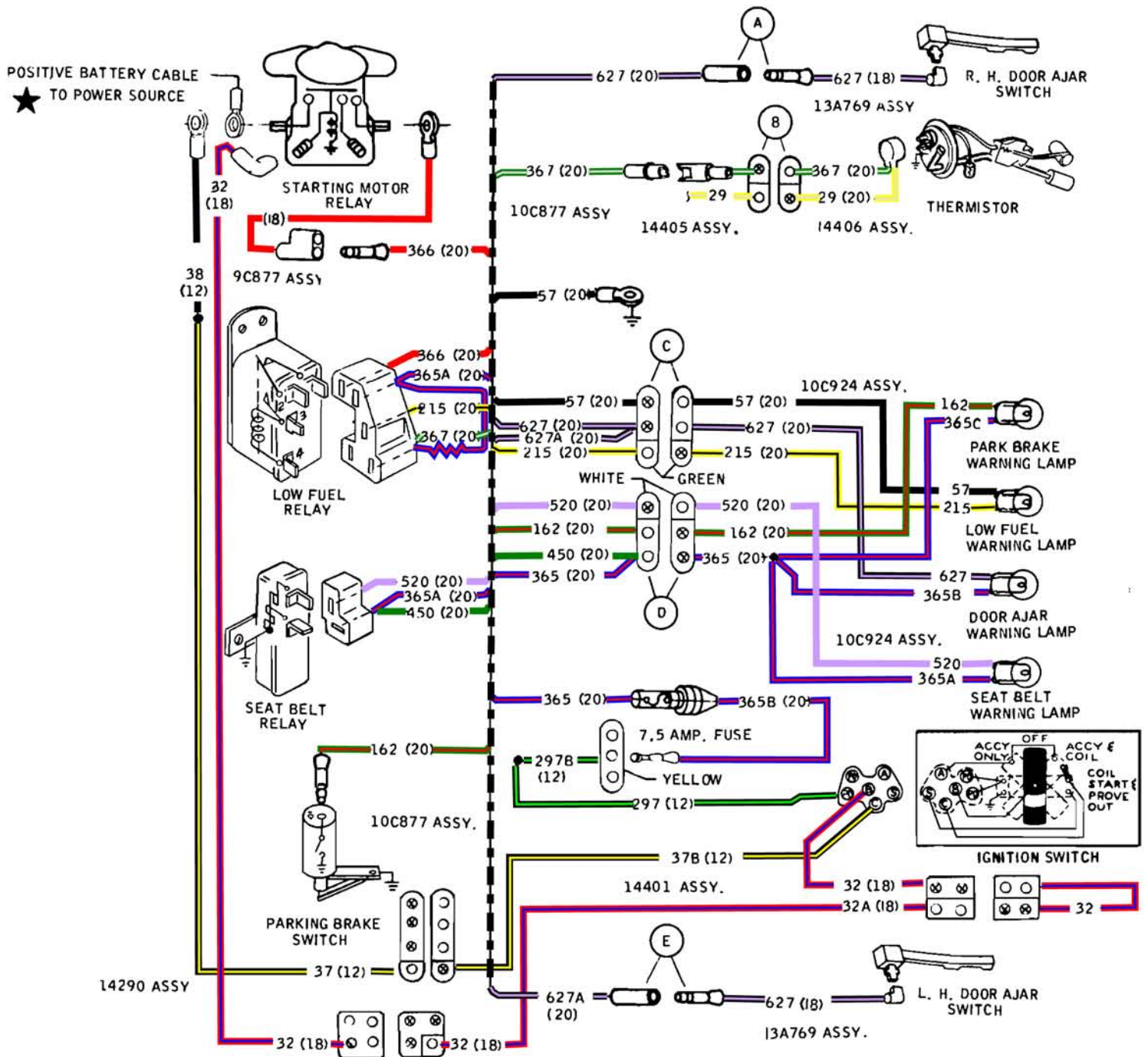

WIRING COLOR CODE

32A 32 RED-BLUE STRIPE	367 GREEN-WHITE STRIPE
37 BLACK - YELLOW	450 GREEN
38 57 BLACK	520 VIOLET
162 GREEN - RED STRIPE	627A 627 BLACK - VIOLET STRIPE
215 YELLOW-BLACK STRIPE	SPLICE
THRU 365C BLUE - RED STRIPE	GROUND
366 RED	

NOTE:
 DETAIL & ITEM REFERENCE SHOWN ON
 PRODUCT DRAWING
 ALL NUMBERS IN PARENTHESIS INDICATE
 WIRE GAUGE

(A) ALL LETTERS CIRCLED AS SHOWN
 INDICATE CONNECTORS



BUY IT NOW!

Click Here To Order



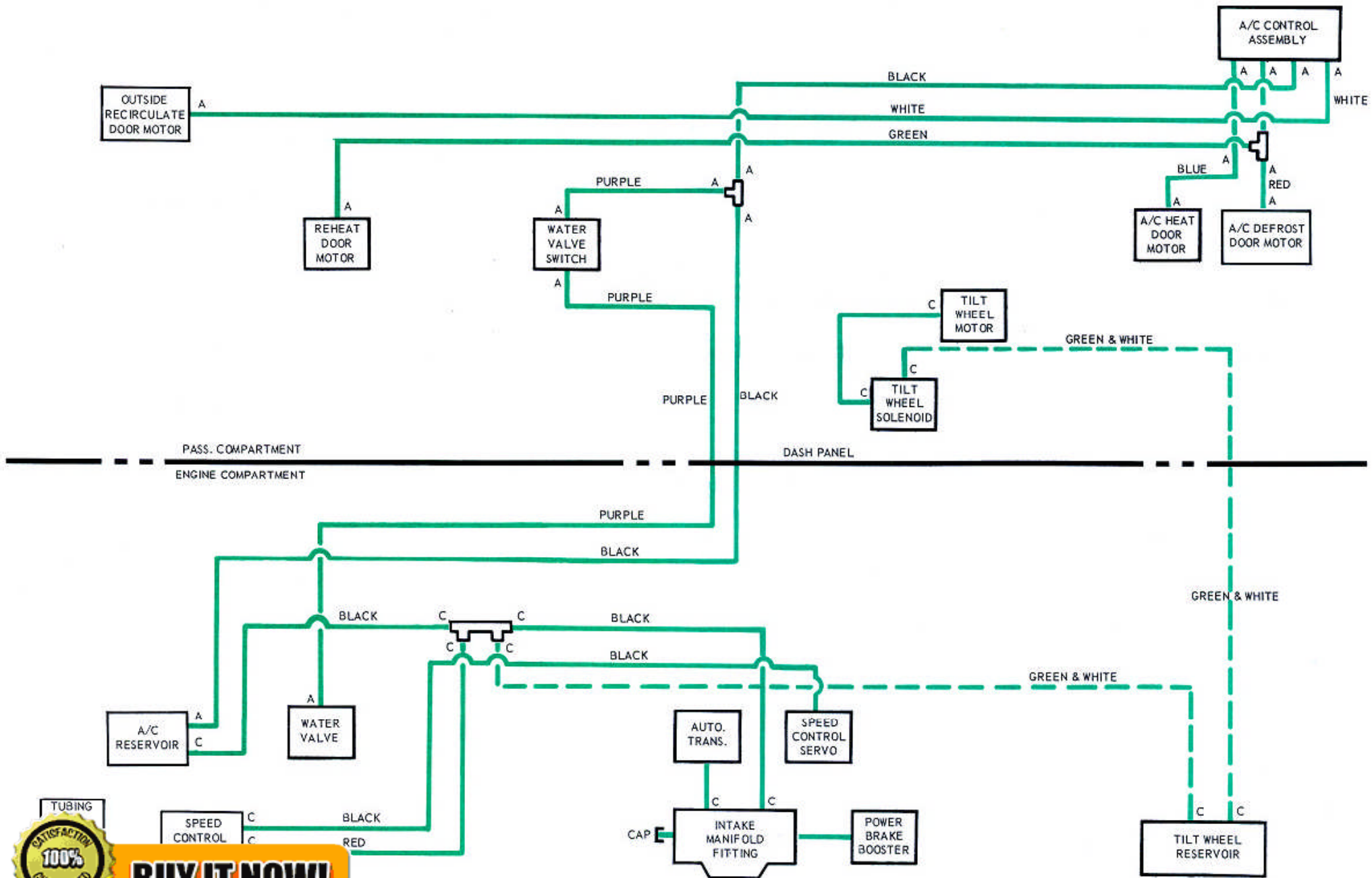

1968 MUSTANG TOTAL VACUUM SCHEMATIC

100% SATISFACTION GUARANTEED

BUY IT NOW!

[Click Here To Order](#)

1965/72 FORD CAR

FINAL ISSUE

Master Parts and Accessories

Source Document
Ford Publication Form FP-7635-B

Form FP 7635-A & B

Supersedes All Previous Issues, Changes and Revisions



Official Licensed Product

5236

FINAL ISSUE



BUY IT NOW!

Click Here To Order

Copyright 1975 --

FORD MOTOR
COMPANY

-- DEARBORN, MICHIGAN

PayPal

Discover
Cards

Discover
Novus

MasterCard

VISA



READY REFERENCE

13001

HOW TO READ WIRING DIAGRAMS



VOL 68 S7 L2A

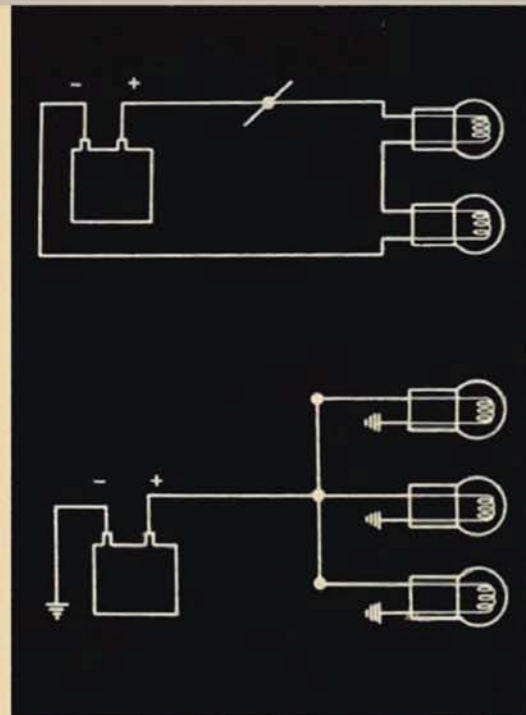

BUY IT NOW!

Click Here To Order



HOW TO READ WIRING DIAGRAMS

COURSE 13001 • VOL. 68 S7 L2A

TABLE OF CONTENTS

Page

INTRODUCTION

A LOGICAL APPROACH TO ELECTRICAL DIAGNOSIS	1
Like reading a road map	2
How wires are numbered and color-coded	2
CIRCUIT – A COMPLETE ELECTRICAL PATH BETWEEN TWO POINTS	5
2-wire circuit	6
Single wire circuit	6
Ground connections	7
OPEN CIRCUITS	8
Shorts	9
Grounded circuit	9
Series and parallel open circuits	10
BREAKS IN PARALLEL CIRCUITS	11
Common points	14
Splices	15
Fuses and circuit breakers	17
Quick disconnects	18
Male and female elements	20
Types of quick disconnects	22
HINTS FOR TRACING WIRES THROUGH A DRAWING	23
Curve directions	23
Common points	24
Switches	25
Relays	26
Assemblies	28
Locating the assembly	29
Finding the wire	30
SUMMARY	31

100% SATISFACTION GUARANTEED

The descriptions, testing procedures, and specifications in this handbook were approved for printing. Ford Motor Company reserves the right to change specifications without notice and without incurring liability.

BUY IT NOW!

Click Here To Order

NATIONAL SERVICE OFFICE
FORD DIVISION



FIRST PRINTING – JANUARY, 1968

© 1968 FORD MOTOR COMPANY
DEARBORN, MICHIGAN

INTRODUCTION

The Why and Wherefore of Wiring Diagrams

To the uninformed, a wiring diagram — or a wiring assembly — looks like it might take a genius to figure out.

Not so — as you'll find out when you get better acquainted with these subjects.

There're as understandable and logical as a road map and road markers, when you're finding your way on a cross-country drive.

The ability to read a wiring diagram and relate it to a vehicle's wiring system is, of course, an essential part of a modern service technician's skill. And it's growing in relative importance, too, due to owner's increasing demands for the comforts and conveniences supplied by electrically-operated options and accessories. This opens up greater opportunities, for the forward-looking technician.

The Purpose of this Booklet . . .

. . . is to acquaint you with the systems by which electrical circuits are traced on vehicles. Specifically, it is designed to help you acquire the ability to make your own power checks, quickly and accurately.

Scope of the Booklet

Basically, this is a printed version of the film, "How to Read a Wiring Diagram." It is in no sense a manual of the shop methods by which electrical repairs are made.

It *can* be a helpful guide that can introduce you to the principles of wiring diagrams and vehicle wiring. As you gain experience in reading wiring diagrams, you'll accumulate your own know-how in this important skill. When it becomes "second nature" to you, these pages will have served their purpose — and yours.



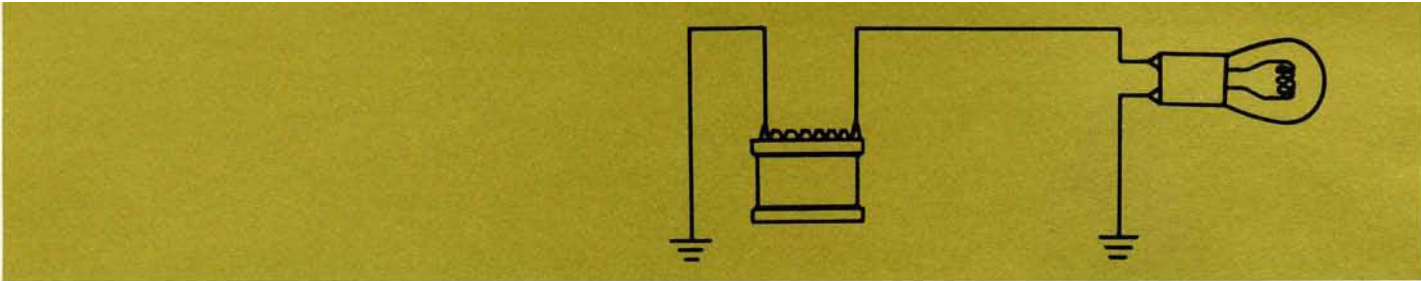

To show how to read wiring diagrams — and to explain how they can be used to help you troubleshoot problems in the electrical system — is what this booklet is all about. Obviously, these are important subjects.

A LOGICAL APPROACH TO ELECTRICAL DIAGNOSIS



If a customer comes in because his headlights aren't working, you can't just make a snap decision. That's not the *professional way*.



When you go to a doctor, for example, he tries to find out what's *really* wrong with you. He looks beyond the aches and pains you feel, to see what's *causing* the trouble. We call this, *diagnosis*.

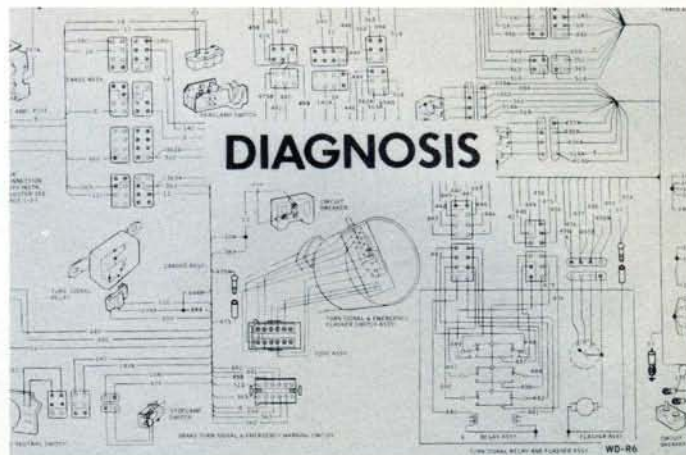

Troubleshooting an electrical system calls for diagnosis, too — *Your* diagnosis. *You're* the doctor. You must find out what's causing the trouble, and fix it.



BUY IT NOW!

Click Here To Order

unit may be the way may not. Snap professional.

