

Colorized

Mustang Wiring & Vacuum Diagrams

(with Electrical Illustrations)

Free Bonus!
30-Minute Video
Ford Training
Course 13001, Vol 68 S7
"How to Read Wiring
Diagrams"
Included!

A consolidated collection of original Ford electrical & vacuum diagrams with illustrations

Color diagrams for:

- Air Conditioner
- Convenience Control Group
- Exterior Lighting and Turn Signals
- Heater-Defroster
- Horns
- Ignition, Starting and Charging
- Instrument Panel
- Interior Lighting
- Pre-Wired Instrument Cluster
- Radio, Stereo and Speakers
- Speed Control

...and much more!!

Licensed and approved
by the Ford Motor Company



BUY IT NOW!

Click Here To Order

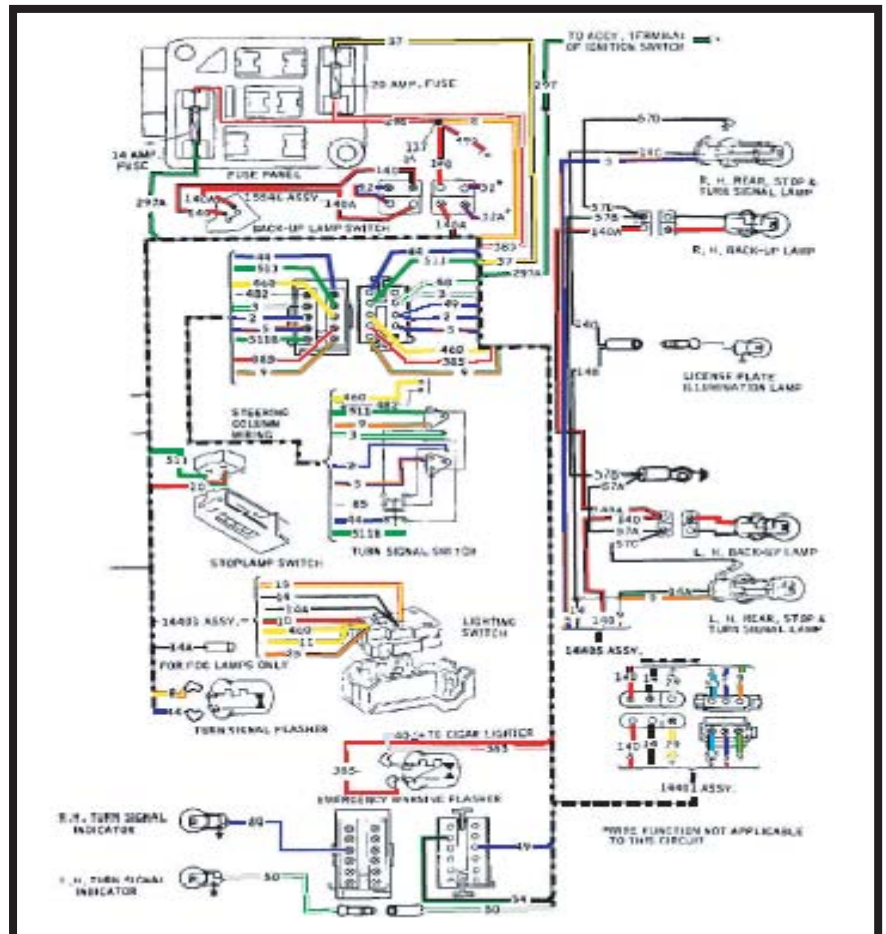

Example of colorized diagrams

Copyright © 2008, Forel Publishing Company, LLC, Woodbridge, Virginia

All Rights Reserved. No part of this book may be used or reproduced in any manner whatsoever without written permission of Forel Publishing Company, LLC. For information write to Forel Publishing Company, LLC, 3999 Peregrine Ridge Ct., Woodbridge, VA 22192

1967 Ford Mustang Wiring and Vacuum Diagrams
(Extracted from Form 7760-67, Form FD-7795P-67, FD-7943-67, FP-7635B, and FD-7943-G)
ISBN: 1-60371-026-4
EAN: 978-1-60371-026-8

Forel Publishing Company, LLC
3999 Peregrine Ridge Ct.
Woodbridge, VA 22192
Email address: webmaster@ForelPublishing.com
Website: <http://www.ForelPublishing.com>



This publication contains material that is reproduced and distributed under a license from Ford Motor Company. No further reproduction or distribution of the Ford Motor Company material is allowed without the express written permission of Ford Motor Company.

Note from the Editor

This product was compiled using several original Ford Motor Company publications. In some cases, there are slight differences between publications, so it is important to compare between diagrams, schematics, or illustrations. The contents of this product were extracted from: *1967 Cougar, Fairlane, Falcon, Mercury and Mustang Shop Manual* (Form 7760-67, March 1967), *1965/1972 Ford Car Master Parts and Accessory Catalog* (Form FP-7635B, May 1975, and *1967 Wiring Diagrams* (Form FD-7795P-67 & FD-7943-67) and *How to Read Wiring Diagrams* (FD-7943-G).

Disclaimer

Although every effort was made to ensure the accuracy of this book, no representations or warranties of any kind are made concerning the accuracy, completeness or suitability of the information, either expressed or implied. As a result, the information contained within this book should be used as general information only. The author and Forel Publishing Company, LLC shall have neither liability nor responsibility to any person or entity with respect to any loss or damage caused, or alleged to be caused, directly or indirectly by the information contained in this book. Further, the publisher and author are not engaged in rendering legal or other professional services. If legal, mechanical, electrical, or other expert assistance is required, the services of a competent professional should be

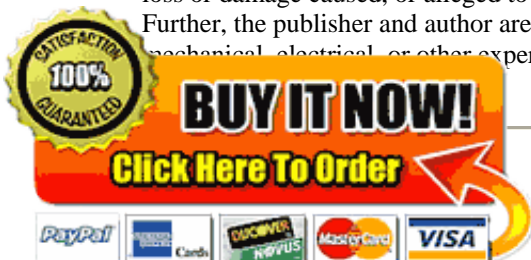



ATTENTION



Please Read This

It is important to note that differences exist between similar or like wiring diagrams even though they are original Ford publications. It is for this reason there may be multiple versions of what appears to be the same wiring diagram. If your vehicle has a color coded wire that does not match a diagram you should consult the other diagrams contained in the manual for a possible match.

Example of differences

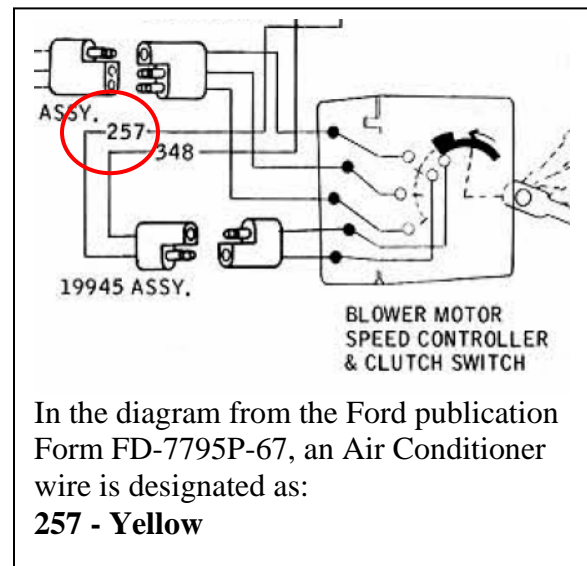
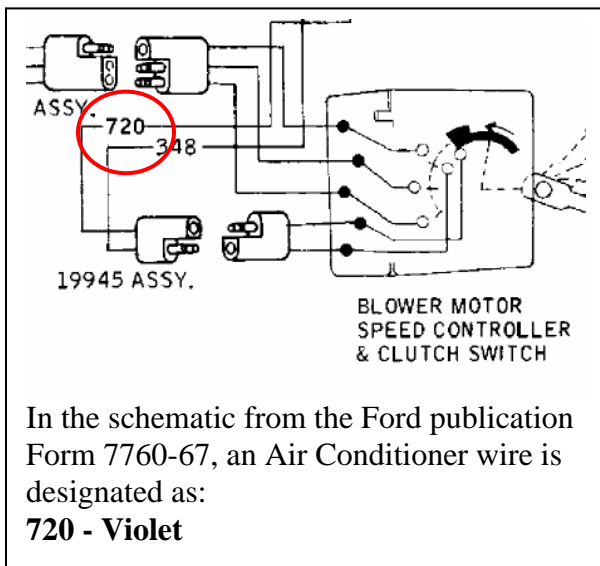

The color coded wiring diagrams are provided for illustration purposes only. Only the wire number should be used for the identification of the wire itself. The color coding of the wires in the product may not match the actual colors of the wires in the vehicle. In some cases, the colors have been altered to provide a visual contrast (i.e. the color white has been shaded to make it more visible). As stated in the paragraph above, there are some variation and/or differences between the original Ford wiring diagrams. If your vehicle has a color coded wire that does not match a diagram you should consult the other diagrams contained in the manual for a possible match.

Disclaimer: Although every effort was made to ensure the accuracy of this book, no representations or warranties of any kind are made concerning the accuracy, completeness or suitability of the information, either expressed or implied. As a result, the information contained within this book should be used as general information only. The author and Forel Publishing Company, LLC shall have neither liability nor responsibility to any person or entity with respect to any loss or damage caused, or alleged to be caused, directly or indirectly by the information contained in this book. Further, the publisher and author are not engaged in rendering legal or other expert assistance. If legal, mechanical, electrical, or other expert assistance is required, professional should be sought.

100% SATISFACTION GUARANTEED

BUY IT NOW!

Click Here To Order

PayPal American Express Discover MasterCard VISA

Color Wiring Codes

Number	Wire Description	Source
2	WHITE-BLUE STRIPE	Form 7760-67
2A	WHITE-BLUE STRIPE	Form 7760-67
3	GREEN-WHITE STRIPE	Form 7760-67
3A	GREEN-WHITE STRIPE	Form 7760-67
4	WHITE-BLACK STRIPE	Form 7760-67
5	ORANGE-BLUE STRIPE	Form 7760-67
8	ORANGE-YELLOW STRIPE	Form 7760-67
9	GREEN-ORANGE STRIPE	Form 7760-67
10	GREEN-RED STRIPE	Form 7760-67
11	BLACK-YELLOW STRIPE	Form 7760-67
11A	BLACK-YELLOW STRIPE	Form 7760-67
12	GREEN-BLACK STRIPE	Form 7760-67
12A	GREEN-BLACK STRIPE	Form 7760-67
13	RED-BLACK STRIPE	Form 7760-67
13A	RED-BLACK STRIPE	Form 7760-67
14	BLACK	Form 7760-67
14A	BLACK	Form 7760-67
14B	BLACK	Form 7760-67
14C	BLACK	Form 7760-67
15	RED-YELLOW STRIPE	Form 7760-67
15B	RED-YELLOW STRIPE	Form 7760-67
16	RED-GREEN STRIPE	Form 7760-67
16A	RED-GREEN STRIPE	Form 7760-67
16A	PINK	FD-7795P-67
16B	RED-GREEN STRIPE	Form 7760-67
19	BLUE-RED STRIPE	Form 7760-67
19A	BLUE-RED STRIPE	Form 7760-67
19B	BLUE-RED STRIPE	Form 7760-67
19C	BLUE-RED STRIPE	Form 7760-67
19D	BLUE-RED STRIPE	Form 7760-67
19E	BLUE-RED STRIPE	Form 7760-67
19F	BLUE-RED STRIPE	Form 7760-67
19G	BLUE-RED STRIPE	Form 7760-67
21	YELLOW	Form 7760-67
22	BLUE-BLACK STRIPE	Form 7760-67
25	BLACK-ORANGE STRIPE	Form 7760-67
	BLACK-RED STRIPE	Form 7760-67
		FD-7795P-67
		Form 7760-67

Number	Wire Description	Source
26A	BLACK	FD-7795P-67
28	BLACK	Form 7760-67
28A	BLACK	Form 7760-67
29	YELLOW-WHITE STRIPE	Form 7760-67
30	BLACK-GREEN STRIPE	Form 7760-67
30A	BLACK-GREEN STRIPE	Form 7760-67
30B	BLACK-GREEN STRIPE	Form 7760-67
30C	BLACK-GREEN STRIPE	Form 7760-67
31	WHITE-RED STRIPE	Form 7760-67
32	RED-BLUE STRIPE	Form 7760-67
32A	RED-BLUE STRIPE	Form 7760-67
34	GREEN-BLACK STRIPE	Form 7760-67
35	WHITE	Form 7760-67
37	BLACK-YELLOW STRIPE	Form 7760-67
37A	BLACK-YELLOW STRIPE	Form 7760-67
38	BLACK	Form 7760-67
39	RED-WHITE STRIPE	Form 7760-67
40	BLUE-WHITE STRIPE	Form 7760-67
44	BLUE	Form 7760-67
49	WHITE-BLUE STRIPE	Form 7760-67
50	GREEN-WHITE STRIPE	Form 7760-67
53	BLACK-BLUE STRIPE	Form 7760-67
53A	BLACK-BLUE STRIPE	Form 7760-67
53B	BLACK-BLUE STRIPE	Form 7760-67
53C	BLACK-BLUE STRIPE	Form 7760-67
53D	BLACK-BLUE STRIPE	Form 7760-67
53E	BLACK-BLUE STRIPE	Form 7760-67
54	GREEN-YELLOW STRIPE	Form 7760-67
54A	GREEN-YELLOW STRIPE	Form 7760-67
54B	GREEN-YELLOW STRIPE	Form 7760-67
54C	GREEN-YELLOW STRIPE	Form 7760-67
56	BLUE	Form 7760-67
57	BLACK	Form 7760-67
57A	BLACK	Form 7760-67
57B	BLACK	Form 7760-67
57C	BLACK	Form 7760-67
57D	BLACK	Form 7760-67
58	WHITE	Form 7760-67
58A	WHITE	Form 7760-67

100% SATISFACTION GUARANTEED

BUY IT NOW!

Click Here To Order

PayPal American Express Discover MasterCard VISA

Color Wiring Codes

Number	Wire Description	Source
63	RED	Form 7760-67
63A	RED	Form 7760-67
85	Unknown	Form 7760-67
122	YELLOW	FD-7795P-67
123	RED	FD-7795P-67
137	YELLOW-BLACK STRIPE	Form 7760-67
140	BLACK-RED STRIPE	Form 7760-67
140A	BLACK-RED STRIPE	Form 7760-67
152	YELLOW	Form 7760-67
162	GREEN-RED STRIPE	FD-7795P-67
175	BLACK	FD-7795P-67
181	BROWN	FD-7795P-67
215	YELLOW-BLACK STRIPE	FD-7795P-67
257	YELLOW	FD-7795P-67
262	BROWN	Form 7760-67
268	RED	FD-7795P-67
269	BLUE	FD-7795P-67
270	BLACK-YELLOW STRIPE	FD-7795P-67
296	RED	Form 7760-67
297	BLACK-GREEN STRIPE	Form 7760-67
297A	BLACK-GREEN STRIPE	Form 7760-67
348	GREEN	FD-7795P-67
348A	GREEN	FD-7795P-67
348B	GREEN	FD-7795P-67
365	BLUE-RED STRIPE	FD-7795P-67
365A	BLUE-RED STRIPE	FD-7795P-67
365B	BLUE-RED STRIPE	FD-7795P-67
365C	BLUE-RED STRIPE	FD-7795P-67
366	RED	FD-7795P-67
367	GREEN-WHITE STRIPE	FD-7795P-67
367A	GREEN-WHITE STRIPE	FD-7795P-67
383	RED-WHITE STRIPE	Form 7760-67
385	WHITE-RED STRIPE	Form 7760-67
450	GREEN	Form 7760-67
450A	GREEN	Form 7760-67
460	YELLOW	Form 7760-67
	GREEN-WHITE STRIPE	Form 7760-67
		Form 7760-67
		Form 7760-67

Number	Wire Description	Source
482A	BLUE-YELLOW STRIPE	Form 7760-67
490	BLUE-RED STRIPE	Form 7760-67
511	GREEN	Form 7760-67
511A	GREEN	Form 7760-67
520	VIOLET	Form 7760-67
615	BLACK	FD-7795P-67
615A	BLACK	FD-7795P-67
627	BLACK-VIOLET STRIPE	FD-7795P-67
627A	BLACK-VIOLET STRIPE	FD-7795P-67
640	RED-YELLOW STRIPE	Form 7760-67
643	YELLOW-BLACK STRIPE	Form 7760-67
654	VIOLET	Form 7760-67
655	YELLOW	Form 7760-67
677	BLUE-BLACK STRIPE	FD-7795P-67
763	ORANGE-WHITE STRIPE	Form 7760-67
763	ORANGE	FD-7795P-67
806	WHITE	Form 7760-67
807	ORANGE	Form 7760-67
863	BLACK-YELLOW STRIPE	Form 7760-67
904	GREEN-RED STRIPE	Form 7760-67
907	BLACK-ORANGE STRIPE	Form 7760-67
908	YELLOW	Form 7760-67
913	YELLOW	FD-7795P-67
914	GREEN	Form 7760-67
914A	GREEN	Form 7760-67
914B	GREEN	Form 7760-67
914C	GREEN	Form 7760-67
920	YELLOW	Form 7760-67
923	VIOLET	Form 7760-67
923A	VIOLET	Form 7760-67
924	RED	Form 7760-67
925	WHITE	Form 7760-67
943	Unknown	Form 7760-67
977	VIOLET	Form 7760-67

*Note – wire color codes highlighted in **RED** designate a difference between original Ford wiring publications. Those highlighted have the same wire number but have different color codes.

100% SATISFACTION GUARANTEED

BUY IT NOW!

Click Here To Order





















PayPal American Express Discover MasterCard VISA













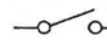

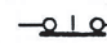
100% GUARANTEED
BUY IT NOW!
 Click Here To Order

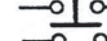
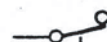
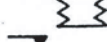
WIRE SYMBOLS

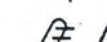







-  HEATER
-  CIRCUIT BREAKER
-  FUSE
-  RESISTOR OR RESISTANCE WIRE
-  DIODE
-  CAPACITOR OR CONDENSER
-  THERMOSTAT (VARIABLE RESISTANCE)
-  THERMISTOR
-  SPARK PLUG
-  GROUND
-  BATTERY
-  MAINTAINED CONTACT
-  MOMENTARY CONTACT
-  SPLICE, WELD OR SOLDER POINT
-  SPLICED WIRES
-  Crossover WIRE (NO CONNECTION)
-  JUNCTION BLOCK
-  HORN
-  BUSS BAR
-  BUS BAR & SPLICE

SWITCHES



-  N.O. (SPST)
-  N.O. (SPST)
-  N.O. (DPST)
-  PUSH TYPE N.C.
-  PUSH TYPE N.O.
-  PUSH TYPE N.O. MULTIPLE POLE
-  PRESSURE OR VACUUM OPERATED N.C.
-  (SPDT) CENTER OFF
-  ROTARY SWITCH
-  MERCURY SWITCH
-  THERMAL SWITCH INTERNAL HEATER N.C.
-  THERMAL SWITCH INTERNAL HEATER N.C.
-  THERMAL SWITCH EXTERNAL HEATER N.C.

N.O. - NORMALLY OPEN
 N.C. - NORMALLY CLOSED
 S.P.S.T. - SINGLE POLE, SINGLE THROW
 D.P.S.T. - DOUBLE POLE, SINGLE THROW
 S.P.D.T. - SINGLE POLE, DOUBLE THROW
 D.P.D.T. - DOUBLE POLE, DOUBLE THROW

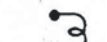

RELAYS

-  N.O. (SPST)
-  N.C. (SPST)
-  SPDT
-  N.O. DPST
-  N.C. DPST
-  SOLENOID
-  COIL AIR CORE
-  IGNITION COIL





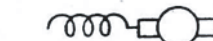



LAMPS

-  SINGLE FILAMENT
-  DOUBLE FILAMENT

MOTORS

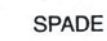
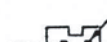
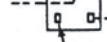
-  BASIC SERIES
-  SPLIT SERIES
-  PERMANENT MAGNET

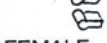
CONNECTORS

-  FEMALE CONNECTOR
-  OFF SET
-  MALE CONNECTOR
-  CONNECTOR NOT USED
-  BULLET CONNECTOR
-  SPADE NOT USED
-  FEMALE SPADE CONNECTOR
-  MALE SPADE CONNECTOR
-  MULTIPLE PLUG
-  COVER FOR CONNECTOR PINS
-  IGNITION SWITCH

- AND/OR * WIRE FUNCTION NOT APPLICABLE TO THIS CIRCUIT
 (14), (16) ETC. ALL NUMBERS IN (A), (B) ETC. ALL LETTERS CIRCLED INDICATE CONNECTION LOCATION.
 ★ TO POWER SOURCE

1967

COUGAR

FAIRLANE

FALCON

MERCURY

INTERMEDIATE

MUSTANG

SHOP MANUAL

Source Document
Ford Publication Form 7760-67



BUY IT NOW!

Click Here To Order 



WIRING COLOR CODE

	720	VIOLET
21	913	YELLOW
	268	RED
	269	BLUE
	270	BLACK-YELLOW STRIPE
348B 348A	348	GREEN
	●	SPLICE
	±	GROUND

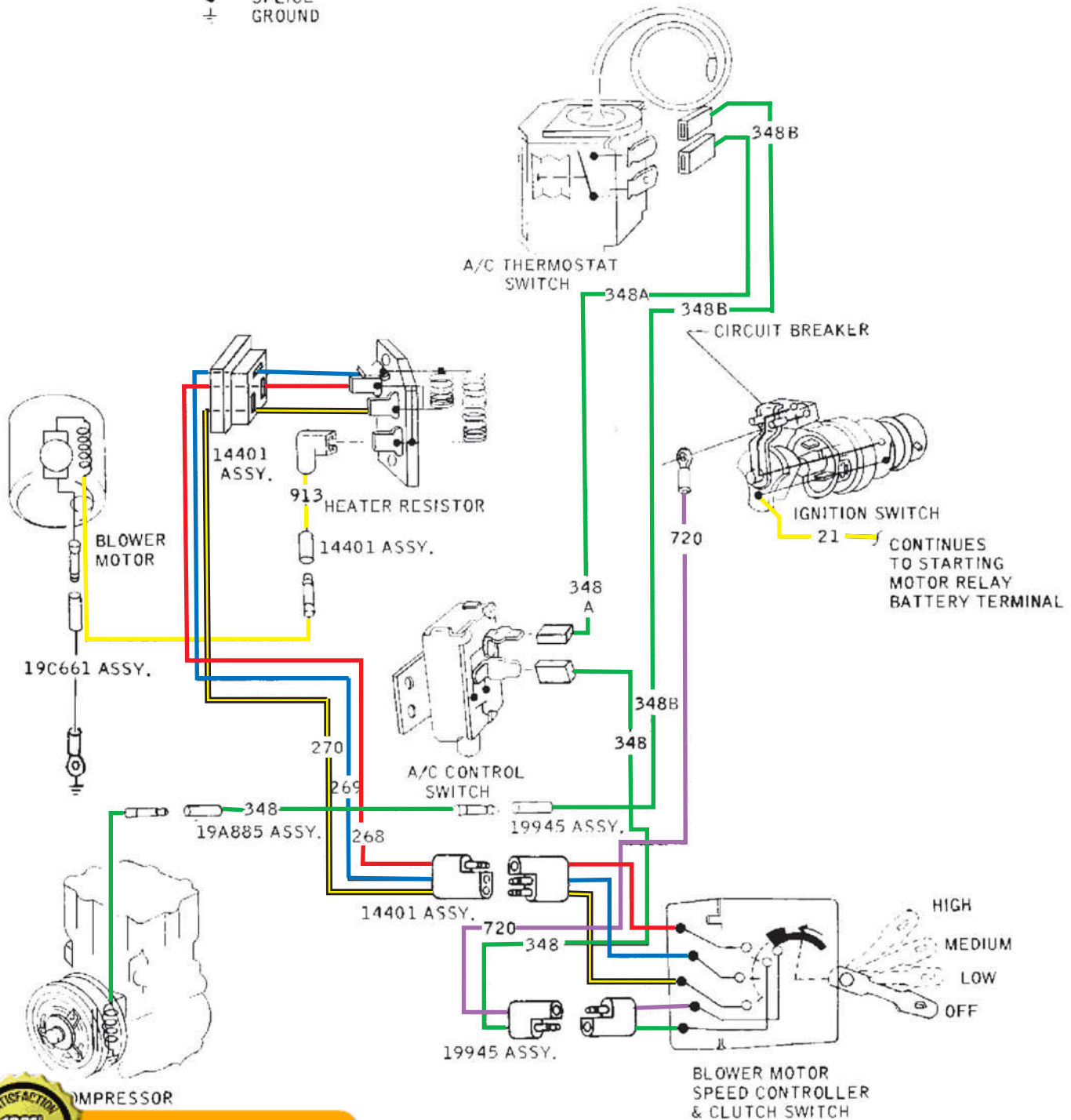

100% SATISFACTION GUARANTEED

BUY IT NOW!

Click Here To Order

PayPal American Express Discover MasterCard VISA

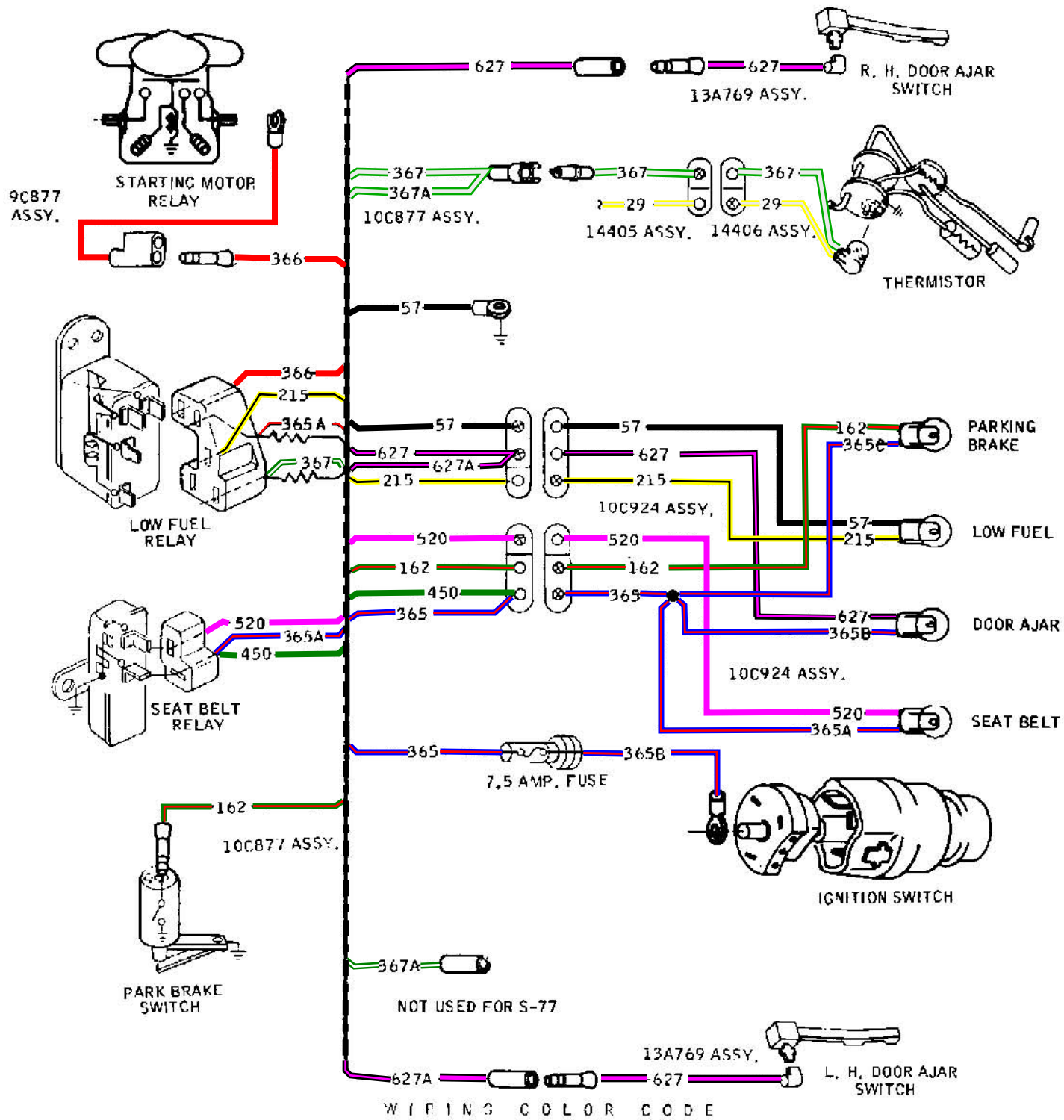

WIRING COLOR CODE

365 THRU 367A	57	BLACK	450	GREEN
366	162	GREEN-RED STRIPE	520	VIOLET
	215	YELLOW-BLACK STRIPE	627	BLACK-VIOLET STRIPE
	365C	BLUE-RED STRIPE	●	SPLICE
	367	GREEN-WHITE STRIPE	⊥	GROUND
	366	RED		
		YELLOW-WHITE STRIPE		

100% SATISFACTION GUARANTEED

BUY IT NOW!

Click Here To Order

PayPal American Express Discover MasterCard VISA

Engine Control Panel

K 2217-B







100% SATISFACTION GUARANTEED
BUY IT NOW!
[Click Here To Order](#)

MUSTANG
 SPEED CONTROL
 1-4

MANIFOLD VACUUM HOSE

36 VACUUM SERVO BELLOWS

SEE VIEW A

VIEW A

VIEW A

WITH AIR CONDITIONER & HEATER

LOWER SPEEDOMETER CABLE

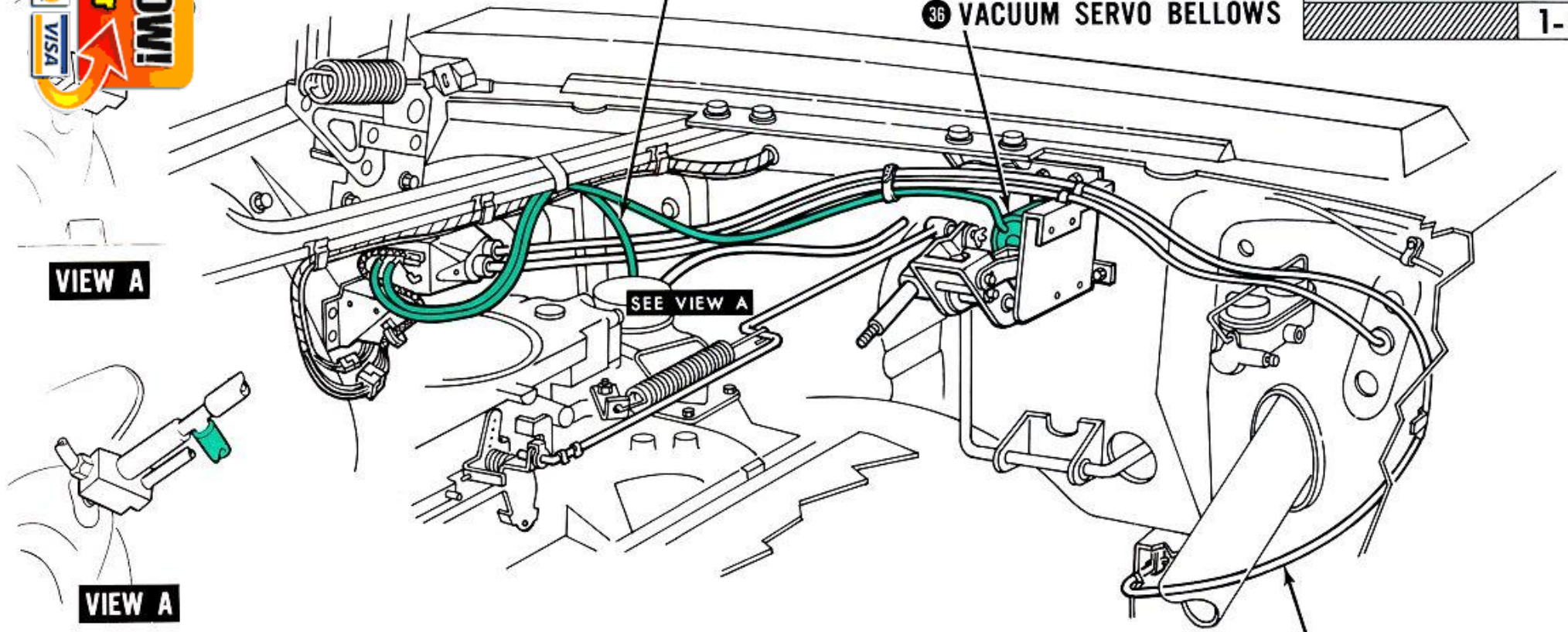

1965/72 FORD CAR

FINAL ISSUE

Master Parts and Accessories

Source Document
Ford Publication Form FP-7635-B

Form FP 7635-A & B

Supersedes All Previous Issues, Changes and Revisions



Official Licensed Product

5236

FINAL ISSUE



Model 1075
BUY IT NOW!

Click Here To Order

Copyright 1975 --

FORD MOTOR
COMPANY

-- DEARBORN, MICHIGAN

PayPal

Discover
Cards

Discover
Novus

MasterCard

VISA

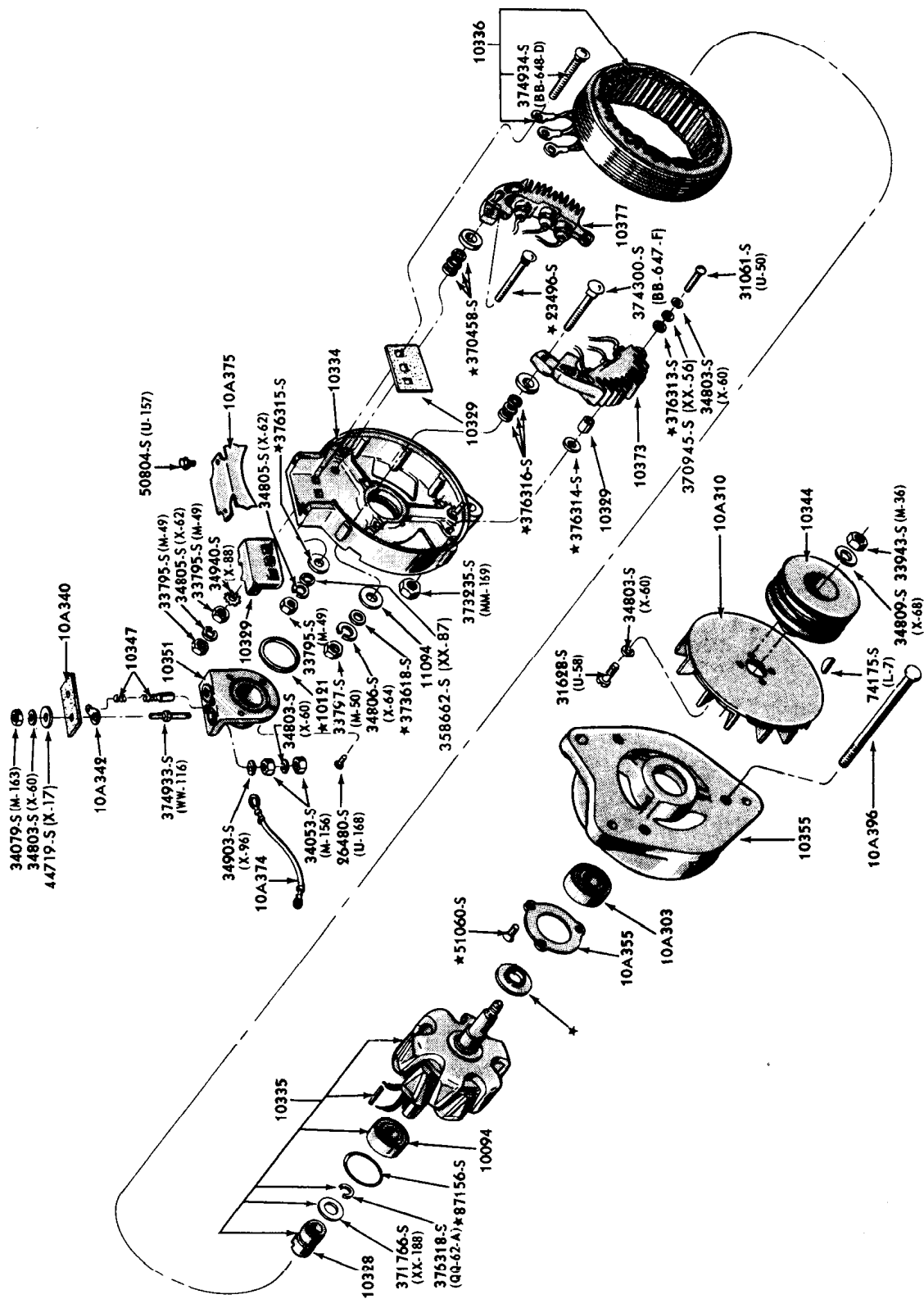

MOTOR (LEECE NEVILLE 15 VOLT - 60, 65 AMP.)

1965/67

100% SATISFACTION GUARANTEED

BUY IT NOW!

Click Here To Order

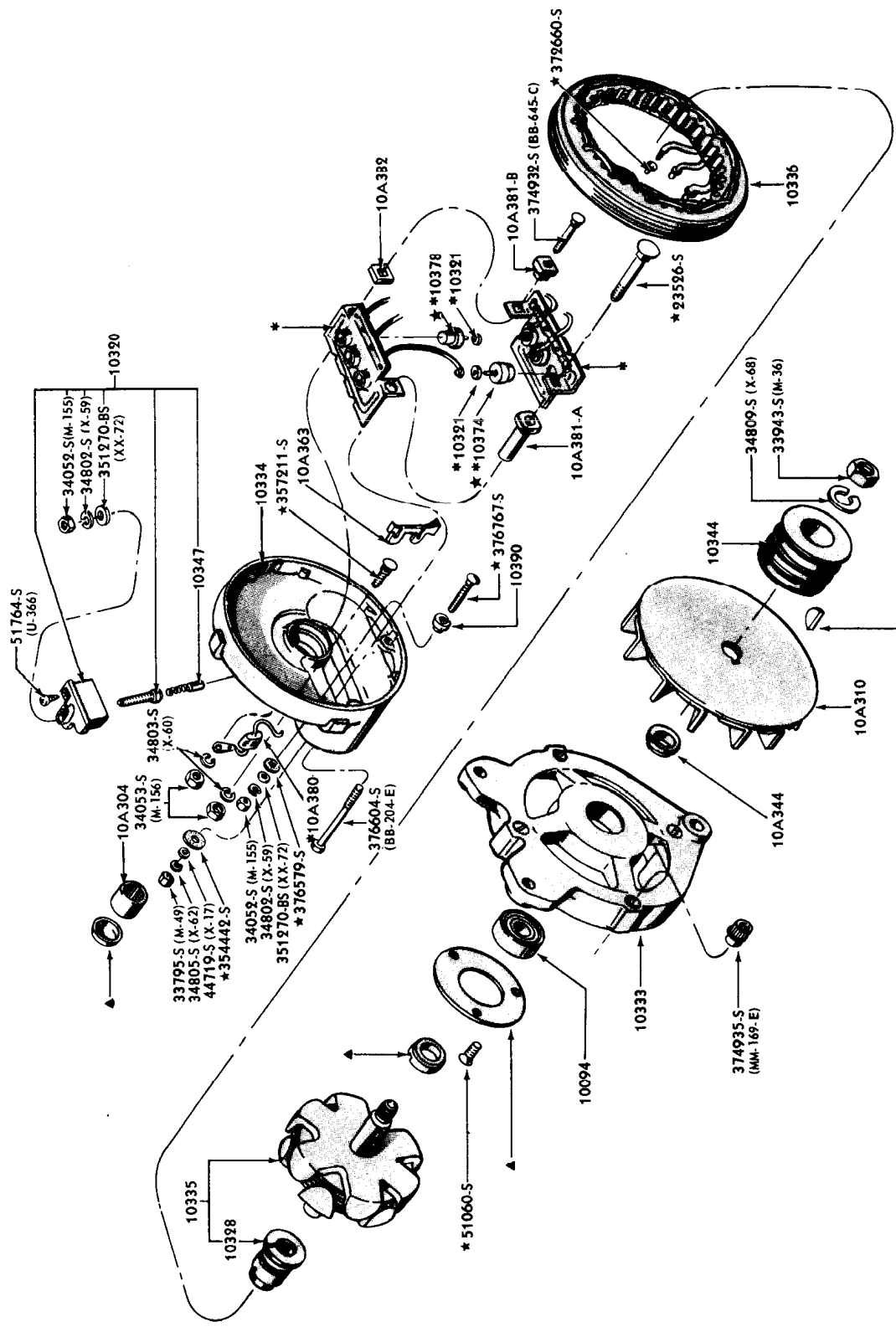

* ALSO SUPPLIED IN 10304 RECTIFIER ASSEMBLY
 ▲ SUPPLIED ONLY IN 10346 ALTERNATOR ASSEMBLY

ALTERNATOR (LEECE NEVILLE 15 VOLT - 40,53 AMP.)
 1965/67

100% SATISFACTION GUARANTEED

BUY IT NOW!

Click Here To Order

PayPal, American Express, Discover, MasterCard, VISA



READY REFERENCE

13001

HOW TO READ WIRING DIAGRAMS



VOL 68 S7 L2A

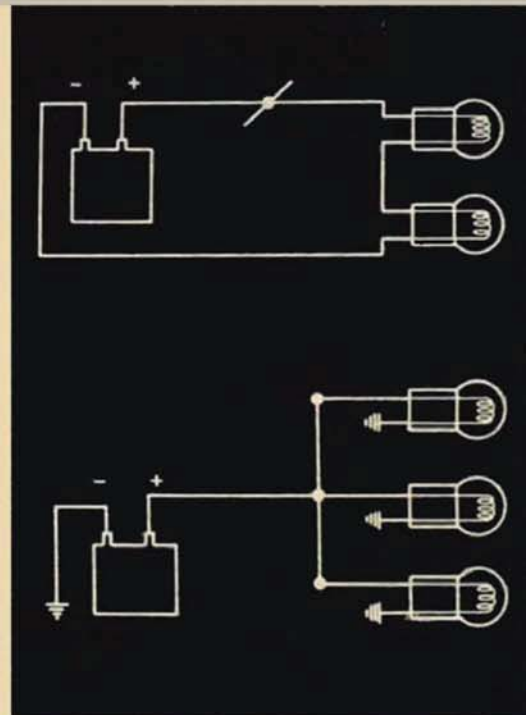

BUY IT NOW!

Click Here To Order



HOW TO READ WIRING DIAGRAMS

COURSE 13001 • VOL. 68 S7 L2A

TABLE OF CONTENTS

Page

INTRODUCTION

A LOGICAL APPROACH TO ELECTRICAL DIAGNOSIS	1
Like reading a road map	2
How wires are numbered and color-coded	2
CIRCUIT – A COMPLETE ELECTRICAL PATH BETWEEN TWO POINTS	5
2-wire circuit	6
Single wire circuit	6
Ground connections	7
OPEN CIRCUITS	8
Shorts	9
Grounded circuit	9
Series and parallel open circuits	10
BREAKS IN PARALLEL CIRCUITS	11
Common points	14
Splices	15
Fuses and circuit breakers	17
Quick disconnects	18
Male and female elements	20
Types of quick disconnects	22
HINTS FOR TRACING WIRES THROUGH A DRAWING	23
Curve directions	23
Common points	24
Switches	25
Relays	26
Assemblies	28
Locating the assembly	29
Finding the wire	30
SUMMARY	31

100% SATISFACTION GUARANTEED

BUY IT NOW!

Click Here To Order

PayPal American Express Discover MasterCard VISA

The descriptions, testing procedures, and specifications in this handbook were approved for printing. Ford Motor Company reserves the right to change specifications without notice and without incurring

NATIONAL SERVICE OFFICE
FORD DIVISION



FIRST PRINTING – JANUARY, 1968

© 1968 FORD MOTOR COMPANY
DEARBORN, MICHIGAN

INTRODUCTION

The Why and Wherefore of Wiring Diagrams

To the uninformed, a wiring diagram — or a wiring assembly — looks like it might take a genius to figure out.

Not so — as you'll find out when you get better acquainted with these subjects.

There're as understandable and logical as a road map and road markers, when you're finding your way on a cross-country drive.

The ability to read a wiring diagram and relate it to a vehicle's wiring system is, of course, an essential part of a modern service technician's skill. And it's growing in relative importance, too, due to owner's increasing demands for the comforts and conveniences supplied by electrically-operated options and accessories. This opens up greater opportunities, for the forward-looking technician.

The Purpose of this Booklet . . .

. . . is to acquaint you with the systems by which electrical circuits are traced on vehicles. Specifically, it is designed to help you acquire the ability to make your own power checks, quickly and accurately.

Scope of the Booklet

Basically, this is a printed version of the film, "How to Read a Wiring Diagram." It is in no sense a manual of the shop methods by which electrical repairs are made.

It *can* be a helpful guide that can introduce you to the principles of wiring diagrams and vehicle wiring. As you gain experience in reading wiring diagrams, you'll accumulate your own know-how in this important skill. When it becomes "second nature" to you, these pages will have served their purpose — and yours.



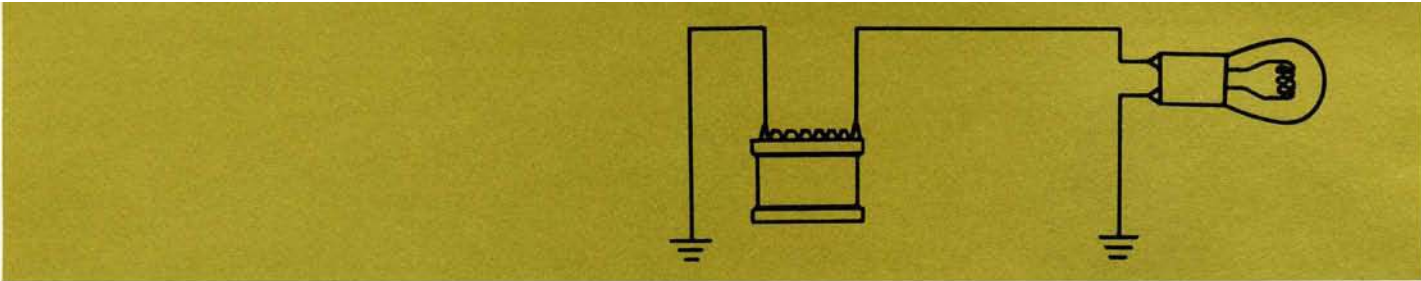

To show how to read wiring diagrams — and to explain how they can be used to help you troubleshoot problems in the electrical system — is what this booklet is all about. Obviously, these are important subjects.

A LOGICAL APPROACH TO ELECTRICAL DIAGNOSIS



If a customer comes in because his headlights aren't working, you can't just make a snap decision. That's not the *professional way*.

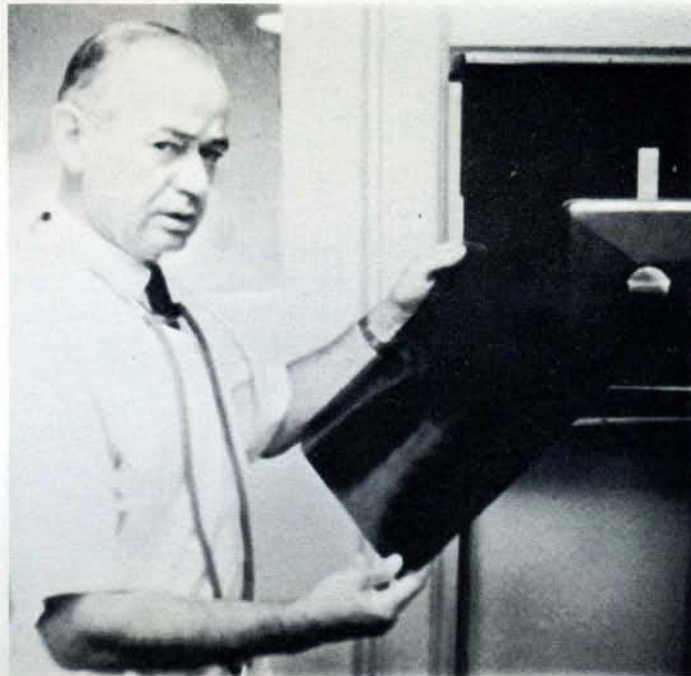

When you go to a doctor, for example, he tries to find out what's *really* wrong with you. He looks beyond the aches and pains you feel, to see what's *causing* the trouble. We call this, *diagnosis*.

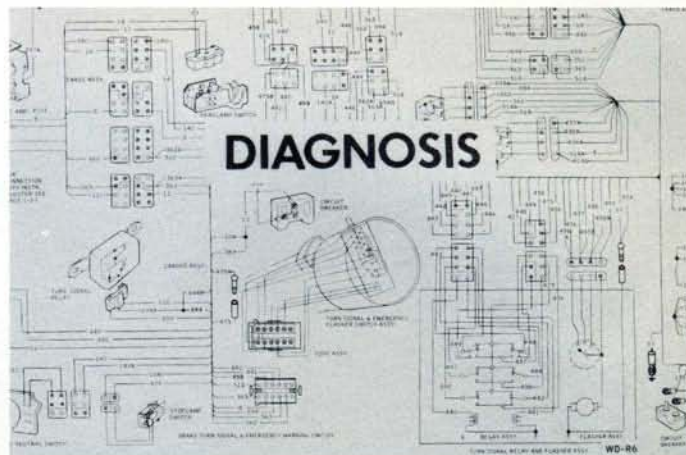

Troubleshooting an electrical system calls for diagnosis, too — *Your* diagnosis. *You're* the doctor. You must find out what's causing the trouble, and fix it.



BUY IT NOW!

Click Here To Order

unit may be the way may not. Snap professional.

