

Colorized

Mustang

Wiring

Diagrams

(with Electrical Illustrations)

Free Bonus!
30-Minute Video
Ford Training
Course 13001, Vol 68 S7
"How to Read Wiring
Diagrams"
Included!

A consolidated collection of original Ford wiring diagrams and electrical illustrations

Diagrams for:

- Accessories
- Radio Stereo Tape Player
- Exterior Lighting, Turn Signals, and Horns
- Ignition, Starting and Charging
- Interior Lighting, Windshield Wipers and Gauges
- Instrument Panel
- Power Top

plus 24 pages of electrical illustrations

...and much more!!

Licensed and approved by the Ford Motor Company



BUY IT NOW!

Click Here To Order

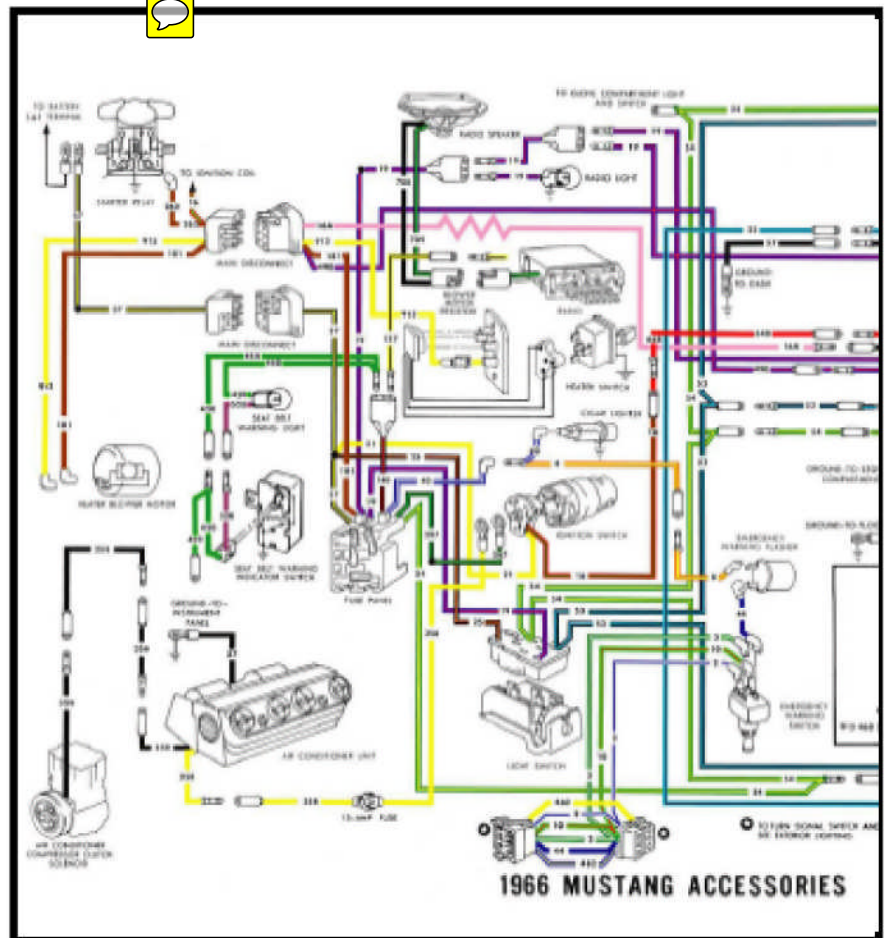

Example of colorized diagrams

Copyright © 2008, Forel Publishing Company, LLC, Woodbridge, Virginia

All Rights Reserved. No part of this book may be used or reproduced in any manner whatsoever without written permission of Forel Publishing Company, LLC. For information write to Forel Publishing Company, LLC, 3999 Peregrine Ridge Ct., Woodbridge, VA 22192

1966 Colorized Mustang Wiring Diagrams
(Extracted from Form FD-7795P-66, Form 7760-66, FP-7635B, and FD-7943-G)
EAN: 978-1-60371-025-1
ISBN: 1-60371-025-6

Forel Publishing Company, LLC
3999 Peregrine Ridge Ct.
Woodbridge, VA 22192
Email address: webmaster@ForelPublishing.com
Website: <http://www.ForelPublishing.com>



This publication contains material that is reproduced and distributed under a license from Ford Motor Company. No further reproduction or distribution of the Ford Motor Company material is allowed without the express written permission of Ford Motor Company.

Note from the Editor

This product was compiled using several original Ford Motor Company publications. In some cases, there are slight differences between publications, so it is important to compare between diagrams, schematics, or illustrations. The contents of this product were extracted from: *1965/1972 Ford Car Master Parts and Accessory Catalog* (Form FP-7635B, May 1975), *1966 Falcon, Comet, Fairlane and Mustang Shop Manual* (Form 7760-66, August 1965) and *1966 Wiring Diagrams* (Form FD-7795P-66) and *How to Read Wiring Diagrams* (FD-7943-G).

Disclaimer

Although every effort was made to ensure the accuracy of this book, no representations or warranties of any kind are made concerning the accuracy, completeness or suitability of the information, either expressed or implied. As a result, the information contained within this book should be used as general information only. The author and Forel Publishing Company, LLC shall have neither liability nor responsibility to any person or entity with respect to any loss or damage caused, or alleged to be caused, directly or indirectly by the information contained in this book. Further, the publisher and author are not engaged in rendering legal or other professional services. If legal, mechanical, electrical, or other expert assistance is required, the services of a competent professional should be sought.





ATTENTION

Please Read This



It is important to note that differences exist between similar or like wiring diagrams even though they are original Ford publications. It is for this reason there may be multiple versions of what appears to be the same wiring diagram. If your vehicle has a color coded wire that does not match a diagram you should consult the other diagrams contained in the manual for a possible match.

Example of differences

WIRING COLOR CODE		
615	57 28.	BLACK
269	56 42	BLUE
	53	RED
950	58 95	WHITE
	96	ORANGE-BLACK STRIPE
	181	ORANGE
297A	297	BLACK-GREEN STRIPE
	763	ORANGE-WHITE STRIPE
	913	YELLOW
	941	BLACK-WHITE STRIPE
	951	GREEN-BLACK STRIPE
		SPLICE

In the schematic from the Ford publication Form 7760-66, a wire is designated as: **181 - Orange**

708	359 57	BLACK
	137	YELLOW-BLACK
	140	BLACK-RED
269	181	BROWN
	648	RED
	482	BLUE-YELLOW
	450	GREEN
	520	VIOLET
		SPLICE

In the diagram from the Ford publication Form FD-7795P-67, wire is designated as: **181 - Brown**

The color coded wiring diagrams are provided for illustration purposes only. Only the wire number should be used for the identification of the wire itself. The color coding of the wires in the product may not match the actual colors of the wires in the vehicle. In some cases, the colors have been altered to provide a visual contrast (i.e. the color white has been shaded to make it more visible). As stated in the paragraph above, there are some variation and/or differences between the original Ford wiring diagrams. If your vehicle has a color coded wire that does not match a diagram you should consult the other diagrams contained in the manual for a possible match.

Disclaimer: Although every effort was made to ensure the accuracy of this book, no representations or warranties of any kind are made concerning the accuracy, completeness or suitability of the information, either expressed or implied. As a result, the information contained within this book should be used as general information only. The author and Forel Publishing Company, LLC shall have neither liability nor responsibility to any person or entity with respect to any loss or damage caused, or alleged to be caused, directly or indirectly by the information contained in this book. Further, the publisher and author are not engaged in rendering legal or other professional services. If legal, mechanical, electrical, or other expert assistance is required, the services of a competent professional should be sought.

100% SATISFACTORY GUARANTEED

BUY IT NOW!

Click Here To Order

PayPal American Express Discover MasterCard VISA

1966 Color Wiring Codes

Number	Wire Description	Source
2	WHITE-BLUE STRIPE	Form 7795-66
3	GREEN-WHITE STRIPE	Form 7795-66
5	ORANGE-BLUE STRIPE	Form 7795-66
7	RED-BLACK STRIPE	Form 7760-66
7A	RED-BLACK STRIPE	Form 7760-66
8	ORANGE-YELLOW STRIPE	Form 7795-66
9	GREEN-ORANGE STRIPE	Form 7795-66
10	GREEN-RED STRIPE	Form 7795-66
10A	GREEN	Form 7795-66
11	BLACK-YELLOW STRIPE	Form 7795-66
11A	BLACK-YELLOW STRIPE	Form 7760-66
12	GREEN-BLACK STRIPE	Form 7795-66
12A	GREEN-BLACK STRIPE	Form 77960-66
13	RED-BLACK STRIPE	Form 7795-66
13a	RED-BLACK STRIPE	Form 7760-66
14	BLACK	Form 7795-66
14A	BLACK	Form 7760-66
14B	BLACK	Form 7760-66
14C	BLACK	Form 7760-66
15	RED-YELLOW STRIPE	Form 7795-66
16	RED-GREEN STRIPE	Form 7795-66
16A	PINK	Form 7795-66
16B	RED-GREEN STRIPE	Form 7760-66
19	BLUE-RED STRIPE	Form 7795-66
19A	BLUE-RED STRIPE	Form 7760-66
19B	BLUE-RED STRIPE	Form 7760-66
19C	BLUE-RED STRIPE	Form 7760-66
19D	BLUE-RED STRIPE	Form 7760-66
19E	BLUE-RED STRIPE	Form 7760-66
19F	BLUE-RED STRIPE	Form 7760-66
19G	BLUE-RED STRIPE	Form 7760-66
19H	BLUE-RED STRIPE	Form 7760-66
19I	BLUE-RED STRIPE	Form 7760-66
19J	BLUE-RED STRIPE	Form 7760-66
19K	BLUE-RED STRIPE	Form 7760-66
21	YELLOW	Form 7795-66
22	BLUE-BLACK STRIPE	Form 7795-66
25	BLACK-ORANGE STRIPE	Form 7795-66

26A	BLACK-RED STRIPE	Form 7760-66
28	BLACK	Form 7795-66
29	YELLOW-WHITE STRIPE	Form 7795-66
30	BLACK-GREEN STRIPE	Form 7795-66
30A	BLACK-GREEN STRIPE	Form 7760-66
30B	BLACK-GREEN STRIPE	Form 7760-66
30C	BLACK-GREEN STRIPE	Form 7760-66
31	WHITE-RED STRIPE	Form 7795-66
32	RED-BLUE STRIPE	Form 7795-66
32A	RED-BLUE STRIPE	Form 7760-66
34	GREEN-BLACK STRIPE	Form 7795-66
35	WHITE	Form 7795-66
37	BLACK-YELLOW STRIPE	Form 7795-66
37A	BLACK-YELLOW STRIPE	Form 7760-66
37B	BLACK-YELLOW STRIPE	Form 7760-66
37C	BLACK-YELLOW STRIPE	Form 7760-66
38	BLACK	Form 7760-66
39	RED-WHITE STRIPE	Form 7795-66
40	BLUE-WHITE STRIPE	Form 7795-66
42	BLUE	Form 7795-66
44	BLUE	Form 7795-66
49	WHITE-BLUE STRIPE	Form 7795-66
50	GREEN-WHITE STRIPE	Form 7795-66
53	BLACK-BLUE STRIPE	Form 7795-66
53A	BLACK-BLUE STRIPE	Form 7760-66
53B	BLACK-BLUE STRIPE	Form 7760-66
54	GREEN-YELLOW STRIPE	Form 7795-66
54A	GREEN-YELLOW STRIPE	Form 7760-66
54B	GREEN-YELLOW STRIPE	Form 7760-66
54C	GREEN-YELLOW STRIPE	Form 7760-66
56	BLUE	Form 7795-66
57	BLACK	Form 7795-66
57A	BLACK	Form 7760-66
58	WHITE	Form 7795-66
61	YELLOW	Form 7795-66
63	RED	Form 7795-66
65	GREEN	Form 7795-66
95	WHITE	Form 7795-66
96	ORANGE-BLACK STRIPE	Form 7795-66
122	YELLOW	Form 7795-66

100% SATISFACTION GUARANTEED

BUY IT NOW!

Click Here To Order

PayPal American Express Discover MasterCard VISA

123	RED	Form 7795-66
137	YELLOW-BLACK STRIPE	Form 7795-66
140	BLACK-RED STRIPE	Form 7795-66
152	YELLOW	Form 7795-66
152A	YELLOW	Form 7760-66
175	BLACK	Form 7795-66
181	ORANGE	Form 7760-66
181	BROWN	Form 7795-66
234	BLACK	Form 7795-66
262	BROWN	Form 7795-66
268	Unknown – Listed but no code	Form 7760-66
269	BLUE	Form 7760-66
297	BLACK-GREEN STRIPE	Form 7795-66
297A	BLACK-GREEN STRIPE	Form 7760-66
358	YELLOW	Form 7795-66
359	BLACK	Form 7795-66
450	YELLOW	Form 7795-66
460	YELLOW	Form 7795-66
477	BLUE-BLACK STRIPE	Form 7795-66
478	GRAY	Form 7795-66
482	BLUE-YELLOW STRIPE	Form 7795-66
482A	BLUE-YELLOW STRIPE	Form 7760-66
490	BLUE-RED STRIPE	Form 7795-66
520	VIOLET	Form 7795-66
615	BLACK	Form 7760-66
640	RED-YELLOW STRIPE	Form 7760-66
643	Unknown – Listed but no code	Form 7760-66
648	RED	Form 7795-66
654	YELLOW	Form 7795-66
655	RED	Form 7795-66
708	BLACK	Form 7795-66
709	BLACK-GREEN STRIPE	Form 7795-66
763	ORANGE-WHITE STRIPE	Form 7795-66
806	WHITE	Form 7795-66
807	ORANGE	Form 7795-66
904	GREEN-RED STRIPE	Form 7795-66
913	YELLOW	Form 7795-66
941	BLACK-WHITE STRIPE	Form 7795-66
950	WHITE	Form 7760-66
	GREEN-BLACK STRIPE	Form 7760-66

Note – wire color codes highlighted in **RED** designate a difference between original Ford wiring publications. Those highlighted have the same wire number but have different color codes depending on the diagram used.

There may be a difference between the *actual* wire colors and those in this manual. In some cases, colors were shaded differently to provide a visual contrast for easier reading.

































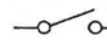

100% GUARANTEED
BUY IT NOW!
 Click Here To Order

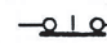
WIRE SYMBOLS

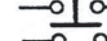
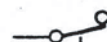
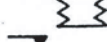

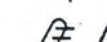





-  HEATER
-  CIRCUIT BREAKER
-  FUSE
-  RESISTOR OR RESISTANCE WIRE
-  DIODE
-  CAPACITOR OR CONDENSER
-  THERMOSTAT (VARIABLE RESISTANCE)
-  THERMISTOR
-  SPARK PLUG
-  GROUND
-  BATTERY
-  MAINTAINED CONTACT
-  MOMENTARY CONTACT
-  SPLICE, WELD OR SOLDER POINT
-  SPLICED WIRES
-  CROSSOVER WIRE (NO CONNECTION)
-  JUNCTION BLOCK
-  HORN
-  BUSS BAR
-  BUS BAR & SPLICE

SWITCHES



-  N.O. (SPST)
-  N.O. (SPST)
-  N.O. (DPST)
-  PUSH TYPE N.C.
-  PUSH TYPE N.O.
-  PUSH TYPE N.O. MULTIPLE POLE
-  PRESSURE OR VACUUM OPERATED N.C.
-  (SPDT) CENTER OFF
-  ROTARY SWITCH
-  MERCURY SWITCH
-  THERMAL SWITCH INTERNAL HEATER N.C.
-  THERMAL SWITCH INTERNAL HEATER N.C.
-  THERMAL SWITCH EXTERNAL HEATER N.C.

N.O. - NORMALLY OPEN
 N.C. - NORMALLY CLOSED
 S.P.S.T. - SINGLE POLE, SINGLE THROW
 D.P.S.T. - DOUBLE POLE, SINGLE THROW
 S.P.D.T. - SINGLE POLE, DOUBLE THROW
 D.P.D.T. - DOUBLE POLE, DOUBLE THROW

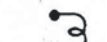

RELAYS

-  N.O. (SPST)
-  N.C. (SPST)
-  SPDT
-  DPDT
-  N.O. DPST
-  N.C. DPST
-  SOLENOID
-  COIL AIR CORE
-  IGNITION COIL





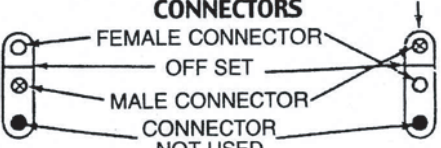

LAMPS

-  SINGLE FILAMENT
-  DOUBLE FILAMENT

MOTORS

-  BASIC SERIES
-  SPLIT SERIES
-  PERMANENT MAGNET
- 

CONNECTORS

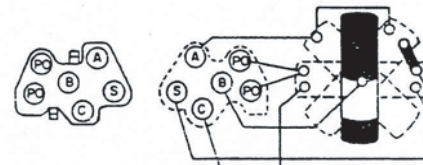
 - FEMALE CONNECTOR
 - OFF SET
 - MALE CONNECTOR
 - CONNECTOR NOT USED
-  BULLET CONNECTOR
-  SPADE NOT USED
-  FEMALE SPADE CONNECTOR
-  MALE SPADE CONNECTOR
-  MULTIPLE PLUG
-  COVER FOR CONNECTOR PINS
- 

IGNITION SWITCH

- AND/OR * WIRE FUNCTION NOT APPLICABLE TO THIS CIRCUIT
 (14), (16) ETC. ALL NUMBERS IN (A), (B) ETC. ALL LETTERS CIRCLED INDICATE CONNECTION LOCATION.
 ★ TO POWER SOURCE

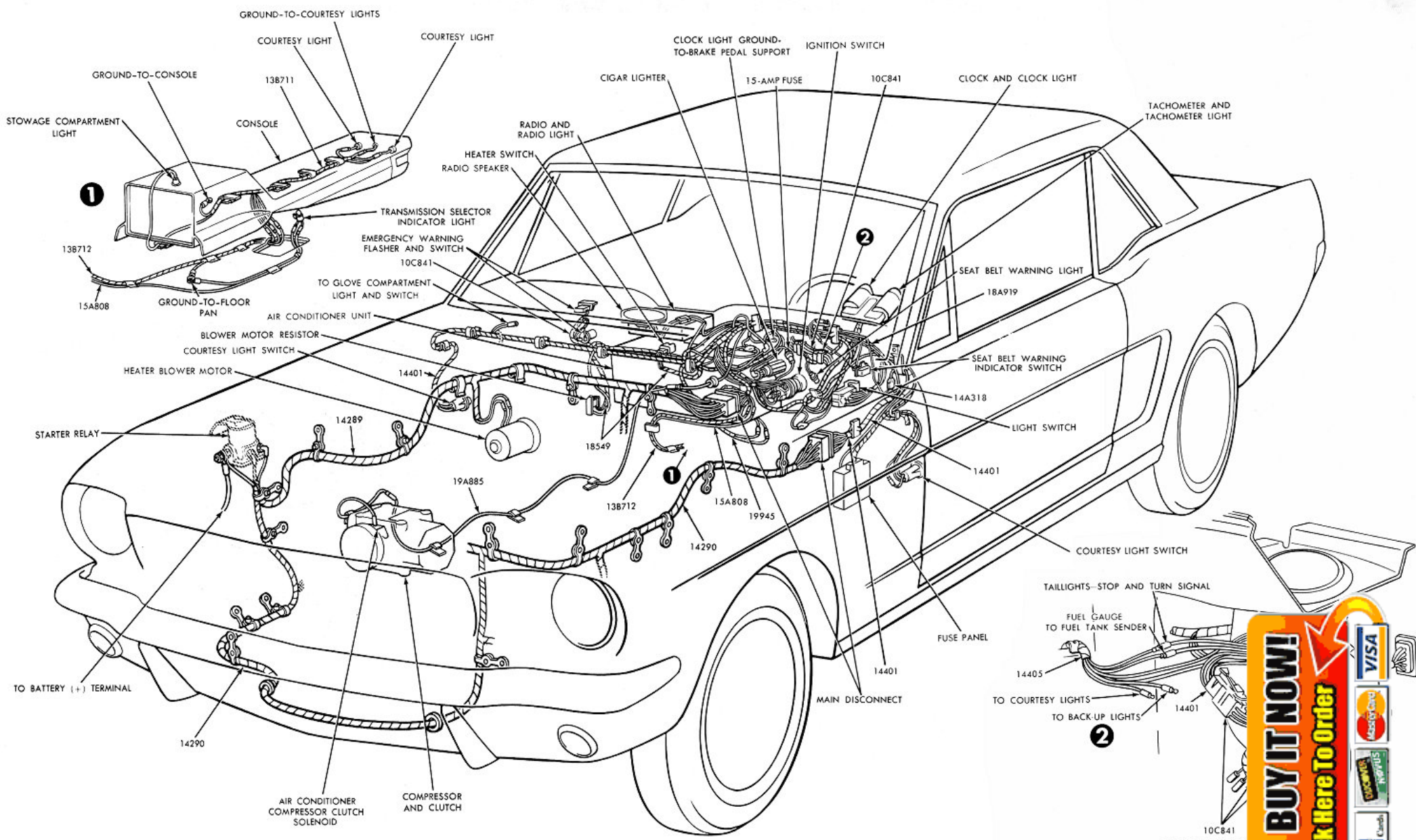

1966 MUSTANG ACCESSORIES

BUY IT NOW!
 Click Here To Order

100% SATISFACTION GUARANTEED

VISA
 MasterCard
 Discover
 American Express
 PayPal

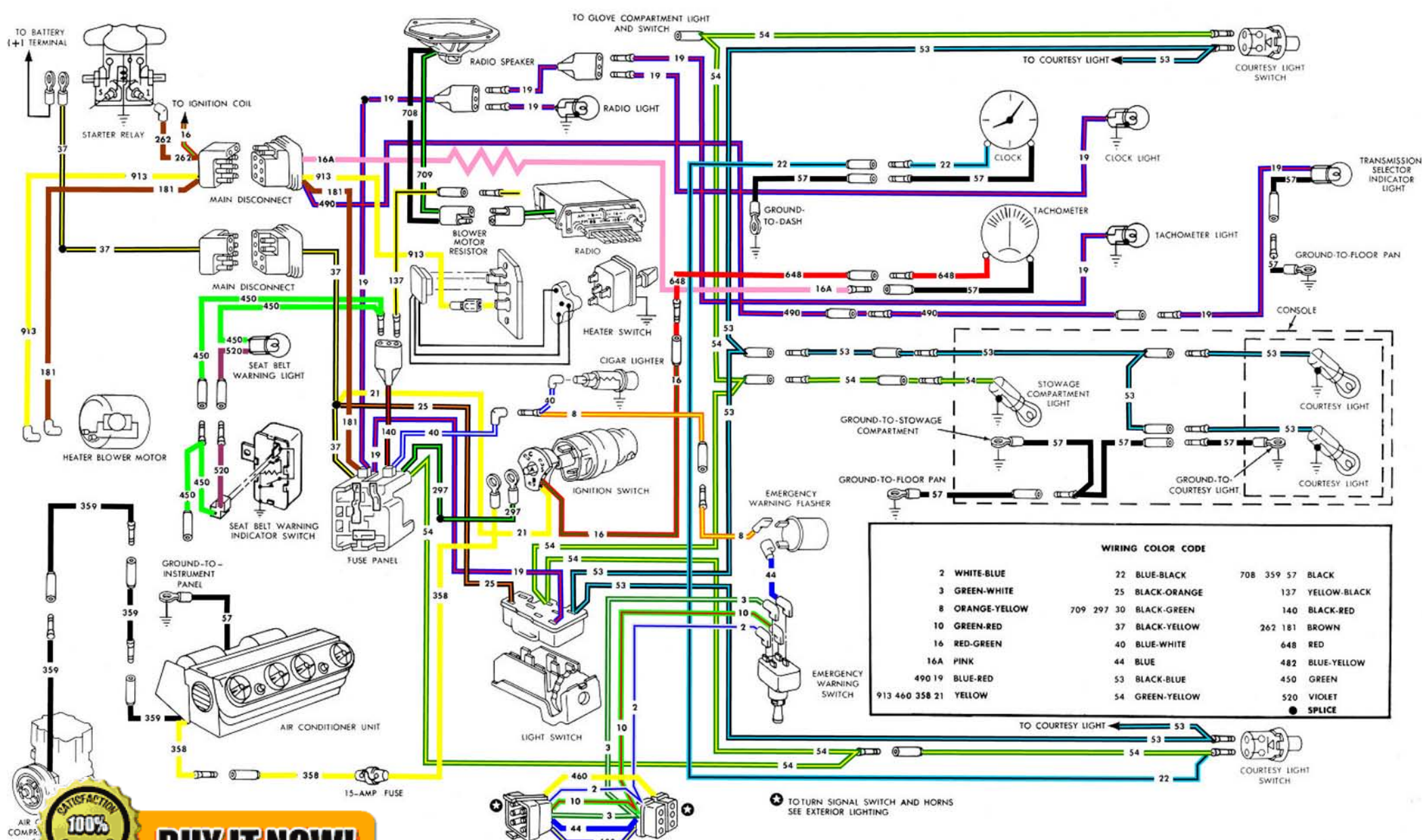

100% SATISFACTION GUARANTEED

BUY IT NOW!

Click Here To Order

1966 MUSTANG ACCESSORIES



**1966
COMET,
FALCON,
FAIRLANE
and
MUSTANG**

Source Document
Ford Publication Form 7760-66

SHOP MANUAL



BUY IT NOW!

Click Here To Order

PayPal

Discover
Cards

Discover
NewUS

MasterCard

VISA

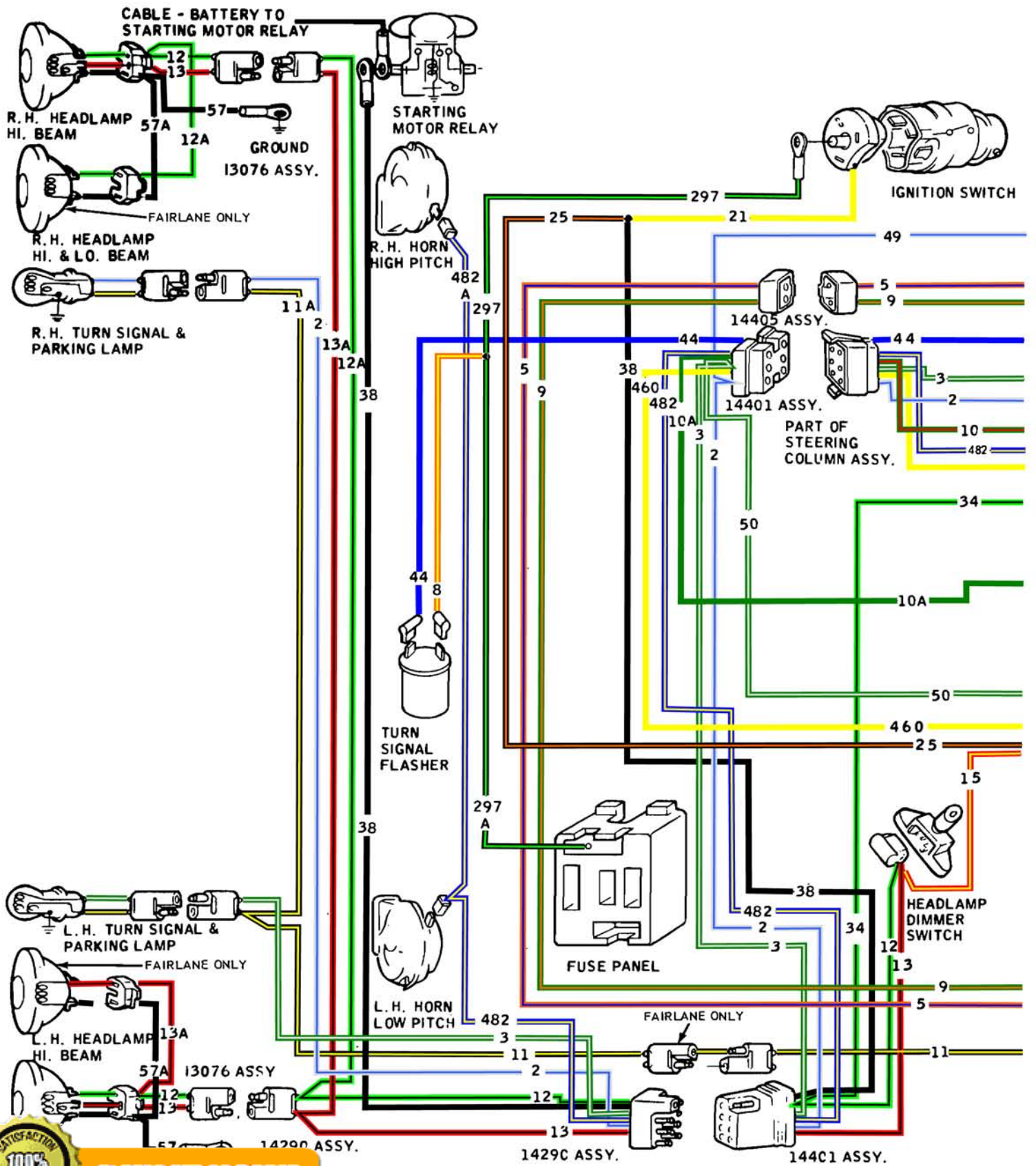

100% SATISFACTION GUARANTEED

BUY IT NOW!

Click Here To Order

5, Turn Signals, and Horns - Except Comet

1965/72 FORD CAR

FINAL ISSUE

Master Parts and Accessories

Source Document
Ford Publication Form FP-7635-B

Form FP 7635-A & B

Supersedes All Previous Issues, Changes and Revisions



Official Licensed Product

5236

FINAL ISSUE



BUY IT NOW!

Click Here To Order

Copyright 1975 --

FORD MOTOR
COMPANY

-- DEARBORN, MICHIGAN

PayPal

Discover
Cards

Discover
Novus

MasterCard

VISA

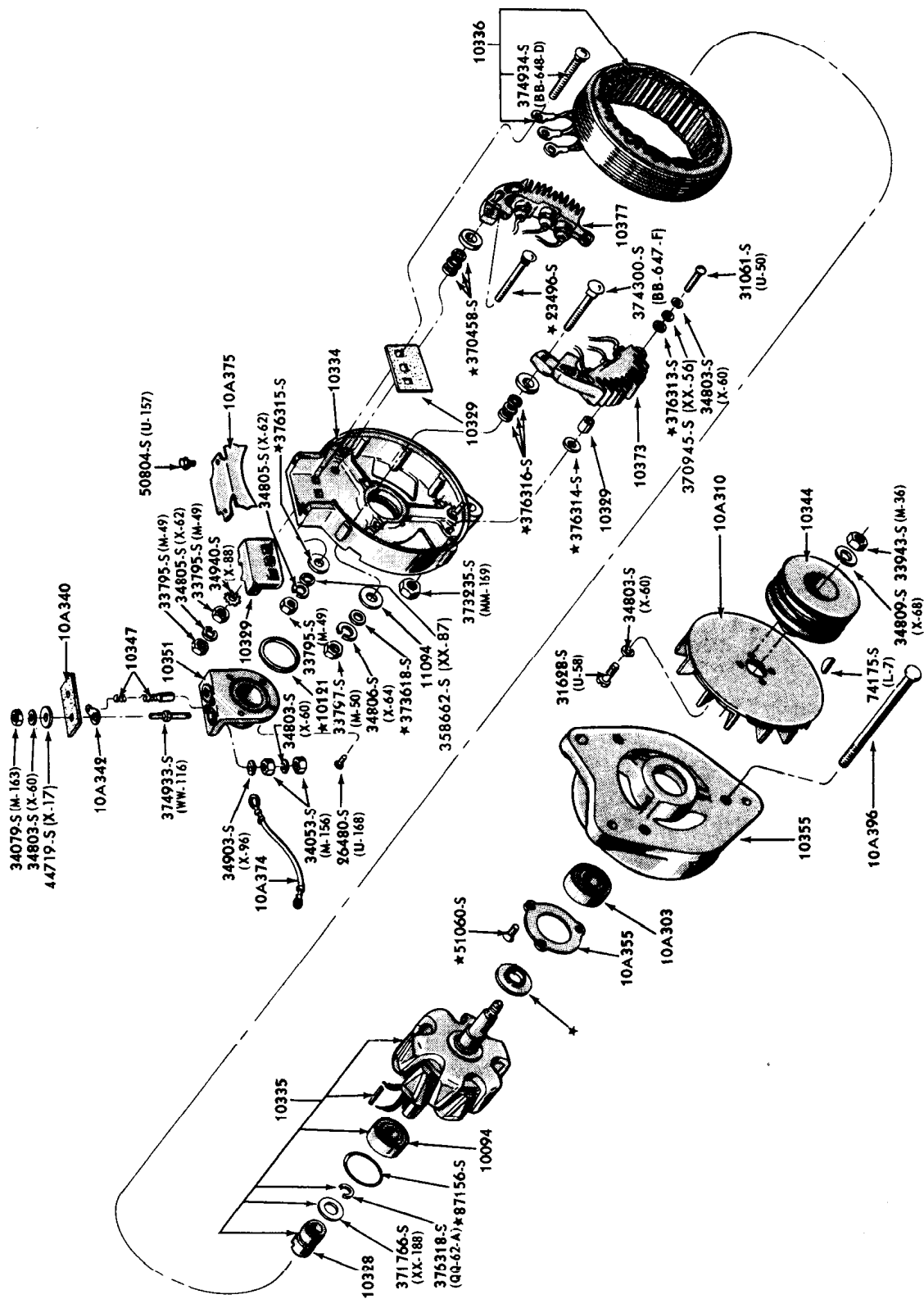

GENERATOR (LEECE NEVILLE 15 VOLT - 60, 65 AMP.)

1965/67

100% SATISFACTION GUARANTEED

BUY IT NOW!

Click Here To Order

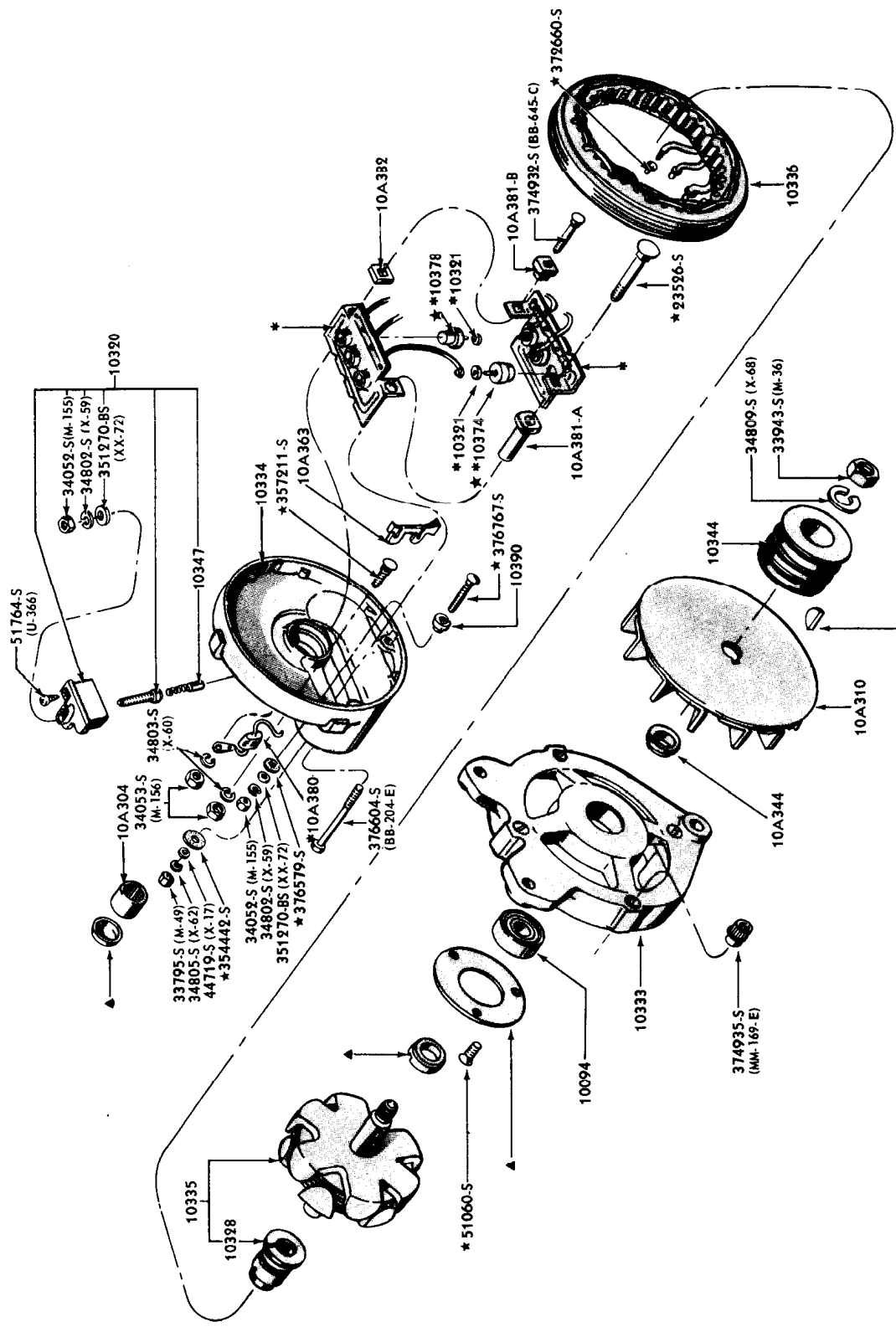

* ALSO SUPPLIED IN 10304 RECTIFIER ASSEMBLY
 ▲ SUPPLIED ONLY IN 10346 ALTERNATOR ASSEMBLY

ALTERNATOR (LEECE NEVILLE 15 VOLT - 40,53 AMP.)
 1965/67

100% SATISFACTION GUARANTEED

BUY IT NOW!

Click Here To Order

PayPal, American Express, Discover, MasterCard, VISA



READY REFERENCE

13001

HOW TO READ WIRING DIAGRAMS



VOL 68 S7 L2A

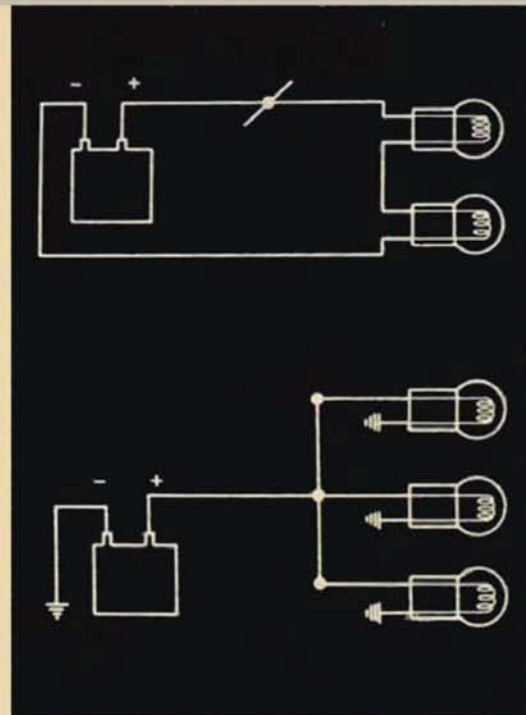

BUY IT NOW!

Click Here To Order



HOW TO READ WIRING DIAGRAMS

COURSE 13001 • VOL. 68 S7 L2A

TABLE OF CONTENTS

Page

INTRODUCTION

A LOGICAL APPROACH TO ELECTRICAL DIAGNOSIS	1
Like reading a road map	2
How wires are numbered and color-coded	2
CIRCUIT – A COMPLETE ELECTRICAL PATH BETWEEN TWO POINTS	5
2-wire circuit	6
Single wire circuit	6
Ground connections	7
OPEN CIRCUITS	8
Shorts	9
Grounded circuit	9
Series and parallel open circuits	10
BREAKS IN PARALLEL CIRCUITS	11
Common points	14
Splices	15
Fuses and circuit breakers	17
Quick disconnects	18
Male and female elements	20
Types of quick disconnects	22
HINTS FOR TRACING WIRES THROUGH A DRAWING	23
Curve directions	23
Common points	24
Switches	25
Relays	26
Assemblies	28
Locating the assembly	29
Finding the wire	30
SUMMARY	31

100% SATISFACTION GUARANTEED

BUY IT NOW!

Click Here To Order

The descriptions, testing procedures, and specifications in this handbook were approved for printing. Ford Motor Company reserves the right to change specifications without notice and without incurring

NATIONAL SERVICE OFFICE
FORD DIVISION



FIRST PRINTING – JANUARY, 1968

© 1968 FORD MOTOR COMPANY
DEARBORN, MICHIGAN

INTRODUCTION

The Why and Wherefore of Wiring Diagrams

To the uninformed, a wiring diagram — or a wiring assembly — looks like it might take a genius to figure out.

Not so — as you'll find out when you get better acquainted with these subjects.

There're as understandable and logical as a road map and road markers, when you're finding your way on a cross-country drive.

The ability to read a wiring diagram and relate it to a vehicle's wiring system is, of course, an essential part of a modern service technician's skill. And it's growing in relative importance, too, due to owner's increasing demands for the comforts and conveniences supplied by electrically-operated options and accessories. This opens up greater opportunities, for the forward-looking technician.

The Purpose of this Booklet . . .

. . . is to acquaint you with the systems by which electrical circuits are traced on vehicles. Specifically, it is designed to help you acquire the ability to make your own power checks, quickly and accurately.

Scope of the Booklet

Basically, this is a printed version of the film, "How to Read a Wiring Diagram." It is in no sense a manual of the shop methods by which electrical repairs are made.

It *can* be a helpful guide that can introduce you to the principles of wiring diagrams and vehicle wiring. As you gain experience in reading wiring diagrams, you'll accumulate your own know-how in this important skill. When it becomes "second nature" to you, these pages will have served their purpose — and yours.



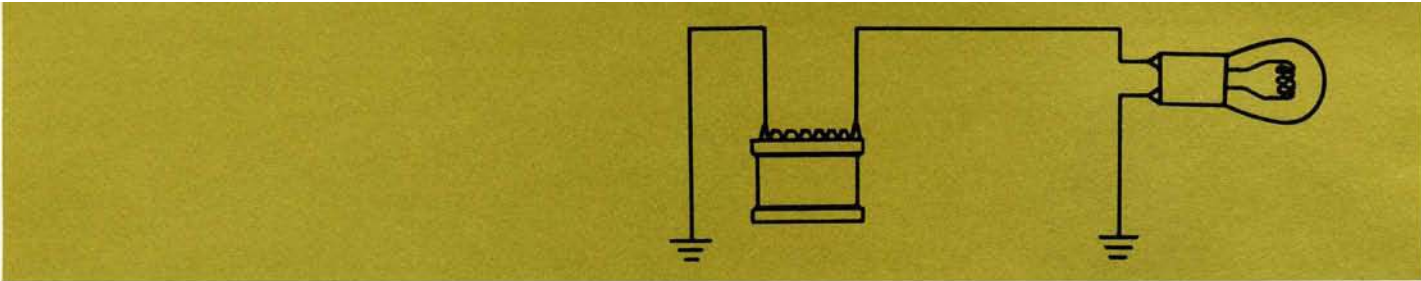

To show how to read wiring diagrams — and to explain how they can be used to help you troubleshoot problems in the electrical system — is what this booklet is all about. Obviously, these are important subjects.

A LOGICAL APPROACH TO ELECTRICAL DIAGNOSIS



If a customer comes in because his headlights aren't working, you can't just make a snap decision. That's not the *professional way*.

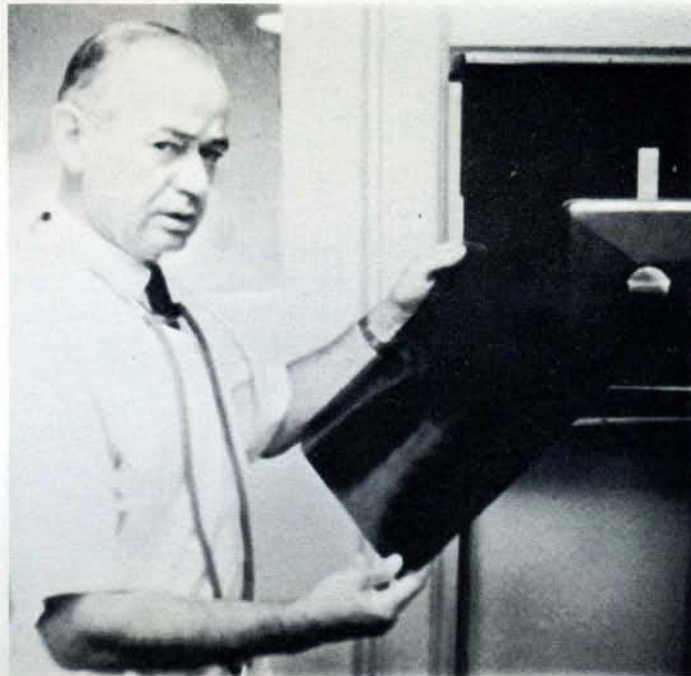

When you go to a doctor, for example, he tries to find out what's *really* wrong with you. He looks beyond the aches and pains you feel, to see what's *causing* the trouble. We call this, *diagnosis*.

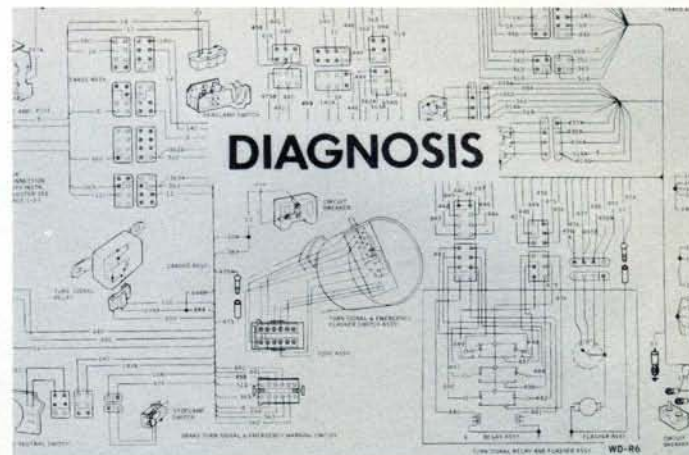

Troubleshooting an electrical system calls for diagnosis, too — *Your* diagnosis. *You're* the doctor. You must find out what's causing the trouble, and fix it.



BUY IT NOW!

Click Here To Order

unit may be the way may not. Snap professional.

