



1964 FORD

TRUCK

850-1100 SERIES



SHOP MANUAL

SUPPLEMENT



BUY IT NOW!

Click Here To Order



PayPal

Discover
Cards

DISCOVER
NOWUS

MasterCard

VISA

Copyright © 2011, Forel Publishing Company, LLC, Woodbridge, Virginia

All Rights Reserved. No part of this book may be used or reproduced in any manner whatsoever without written permission of Forel Publishing Company, LLC. For information write to Forel Publishing Company, LLC, 3999 Peregrine Ridge Ct., Woodbridge, VA 22192

1964 Ford Truck Shop Manual (850-1100 Series)

EAN: 978-1-60371-071-8

ISBN: 1-60371-071-X

Forel Publishing Company, LLC

3999 Peregrine Ridge Ct.

Woodbridge, VA 22192

Email address: sales@ForelPublishing.com

Website: <http://www.ForelPublishing.com>



This publication contains material that is reproduced and distributed under a license from Ford Motor Company. No further reproduction or distribution of the Ford Motor Company material is allowed without the express written permission of Ford Motor Company.

Note from the Publisher

This product was created from the original Ford Motor Company's publication. Every effort has been made to use the original scanned images, however, due to the condition of the material; some pages have been modified to remove imperfections.

Disclaimer

Although every effort was made to ensure the accuracy of this book, no representations or warranties of any kind are made concerning the accuracy, completeness or suitability of the information, either expressed or implied. As a result, the information contained within this book should be used as general information only. The author and Forel Publishing Company, LLC shall have neither liability nor responsibility to any person or entity with respect to any loss or damage caused, or alleged to be caused, directly or indirectly by the information contained in this book. Further, the publisher and author are not engaged in rendering legal or other professional services. If legal, mechanical, electrical, or other expert assistance is required, the professional should be sought.



1964 FORD

TRUCK

850-1100 SERIES

SHOP MANUAL SUPPLEMENT



BUY IT NOW!

Click Here To Order



ENT
ON
ANY

IN, MICHIGAN

GROUP INDEX

IDENTIFICATION	1
BRAKES	2
SUSPENSION—STEERING—WHEELS & TIRES	3
REAR AXLE	4
CLUTCH—DRIVELINE	5
MANUAL TRANSMISSION	6
AUTOMATIC TRANSMISSION	7
ENGINE	8
IGNITION SYSTEM	9
FUEL SYSTEM	10
COOLING SYSTEM	11
EXHAUST SYSTEM	12
CHARGING SYSTEM	13
STARTING SYSTEM	14
LIGHTING SYSTEM, HORNS & INSTRUMENTS	15
VENTILATING, HEATING & ACCESSORIES	16
BODY, DOORS & WINDOWS	17
INTERIOR TRIM & SEATS	18
MAINTENANCE SCHEDULE	19
MAINTENANCE OPERATIONS	20
LUBRICATION CHARTS	21
SPECIAL SERVICE TOOLS	22
SPECIFICATIONS	23

SPECIFICATIONS AT END OF EACH GROUP

FOREWORD

This shop manual supplement, when used with the 1961 shop manual and the 1962-63 shop manual supplement, provides the Service Technician with complete information for the proper servicing of the 1964 850-1100 Series Trucks.

All testing, adjustment and repair procedures that are new for 1964, as well as specifications, maintenance information and recommended specials tools, are included in this manual.

The descriptions and specifications in this manual were in effect at the time this manual was approved for printing. The Ford Motor Company reserves the right to discontinue models at any time, or change specifications or design, without notice and without incurring obligation.

SERVICE DEPARTMENT

FORD MOTOR COMPANY



FORD TRUCK IDENTIFICATION

WARRANTY NUMBER

The warranty number identifies the truck series, engine, assembly plant, and the consecutive unit number.

The complete official serial number is stamped on various frame and body locations. This number is the same as the warranty number, but is preceded and followed by asterisks.

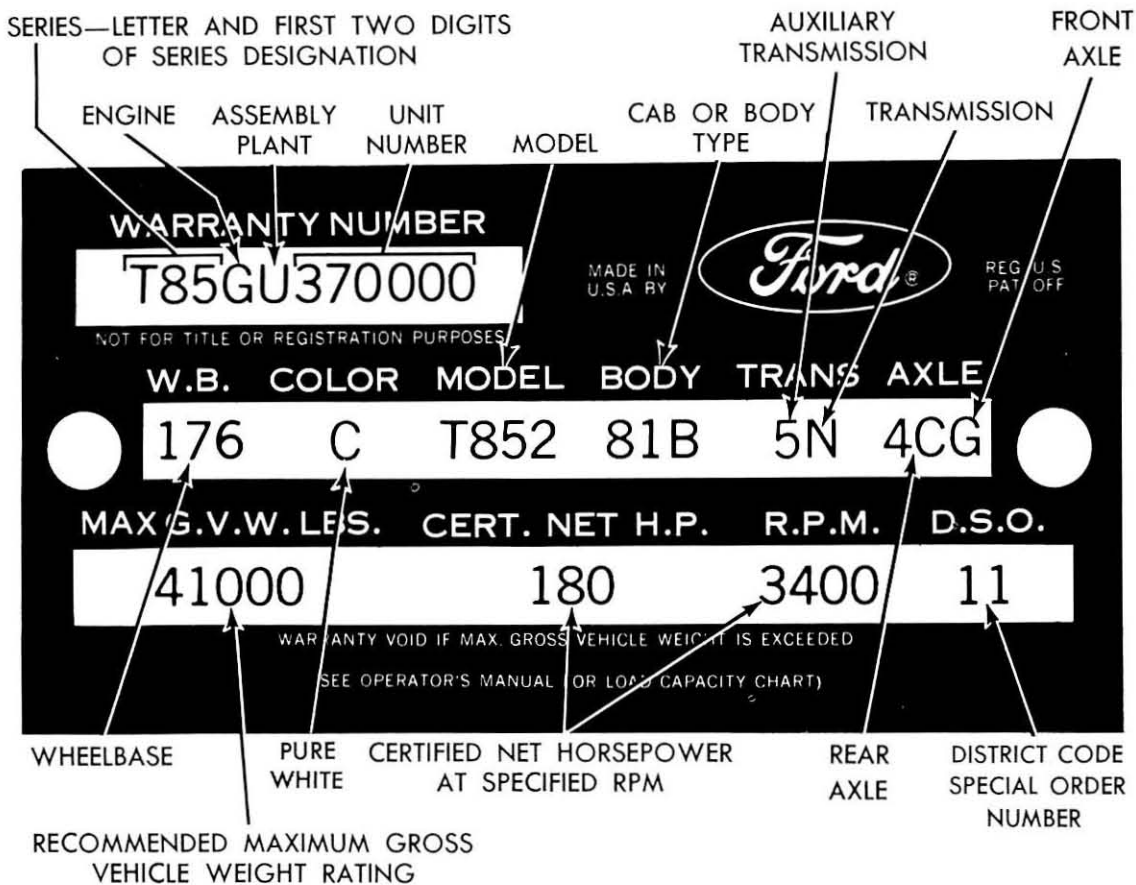

P1118-A

FIG. 1—Typical Rating Plate

MODEL DESIGNATIONS

Model designations consist of two elements—a letter and a three- or four-digit number. The number determines the type. The letter determines the size.

Code Letter	Series
J	Fwd. Axle Tilt Cab Tandem Rear Axle—Gas
K	Conventional 2 Axle—Diesel
L	Tilt Cab Tandem Rear Axle—Gas
N	89" BBC Conventional 2 Axle—Gas
U	Conventional Tandem Rear Axle—Gas
R	89" BBC Conventional 2 Axle—Diesel
S	89" BBC Conventional Tandem Rear Axle—Diesel
T	Conventional Tandem Rear Axle—Gas
W	89" Conventional Tandem Rear Axle—Diesel
Y	Fwd. Axle Tilt Cab 2 Axle—Diesel

Code Letter Series

Fwd. Axle Tilt Cab Tandem Rear Axle—Diesel
Tilt Cab 2 Axle—Gas
Tilt Cab 2 Axle—Diesel
Conventional 2 Axle—Gas
Tilt Cab 2 Axle—Gas

100% SATISFACTION GUARANTEED

BUY IT NOW!

Click Here To Order

PayPal American Express Discover MasterCard VISA

ENGINE CODE

Code	Cubic Inch Displacement	Cylinders
G.....	401—2V.....	8
H.....	477—2V.....	8
P.....	401—4V.....	8
Q.....	477—4V.....	8
R.....	534—4V.....	8
φ.....	855 Cummins (NH-250).....	6
V.....	672 Cummins (NH-180).....	6
X.....	743 Cummins (NH-220).....	6
Y.....	743 Cummins (NHE-180).....	6
Z.....	743 Cummins (NHE-195).....	6
3.....	784 Cummins (V8-265).....	8
6.....	588 Cummins (V6E-195).....	8
7.....	785 Cummins (V8E-235).....	8
8.....	855 Cummins (NHE-225).....	6

ASSEMBLY PLANT CODE

Code	Plant
U.....	Louisville

CONSECUTIVE UNIT NUMBER

1964 unit numbering for most units begins with 370,000 and continues on for each unit built. Models F-856, F-857, F-957, F-958, F-959, K-957, K-958, K-959, K-960, K-961, N-856, N-857, N-957, N-958, N-959, R-957, R-958, R-959, R-960, R-961, C-855, C-957, C-958, all NT-850-D Series, and all CT-800 Series begin with 465,000.

WHEEL BASE

The wheelbase of the truck is stamped in inches under "W.B." of the rating plate.

COLOR CODE

Code	Color Name	*Paint Spec. Number
A.....	Raven Black.....	M-30-J-1724
M.....	Wimbledon White.....	M-30-J-1238
V.....	Academy Blue.....	M-30-J-1024
L.....	Holly Green.....	M-30-J-1237
J.....	Rangoon Red.....	M-30-J-1515
B.....	Caribbean Turquoise.....	M-30-J-556
C.....	Pure White.....	M-30-J-1525
S.....	Mint Green.....	M-30-J-1373
G.....	Chrome Yellow.....	M-30-J-1526
T.....	Navajo Beige.....	M-30-J-1543
K.....	Bengal Tan.....	M-30-J-1706
Y.....	Glacier Blue.....	M-30-J-1623

*"M-32-J" alternate with "M-30-J"

AUXILIARY TRANSMISSION CODE

Code	Type	Ratio
3	3-Speed H.D. Spicer 7231-B	1.24/0.86
4	3-Speed H.D. Spicer 7231-D	2.14/0.86
5	4-Speed Spicer 8341-A	2.40/1.29/0.84
6	3-Speed Spicer 8031-C	2.59/0.79
7	3-Speed Spicer 8031-P	1.19/0.84
8	4-Speed Spicer 7041	2.31/1.21/0.83

NOTE: When required, the auxiliary transmission code will be stamped directly in front of the transmission code.

Code	District
14.....	Pittsburgh
15.....	Newark
21.....	Atlanta
22.....	Charlotte
23.....	Philadelphia
24.....	Jacksonville
25.....	Richmond
26.....	Washington
31.....	Buffalo
32.....	Cleveland
33.....	Detroit
34.....	Indianapolis
35.....	Lansing
36.....	Louisville
41.....	Chicago
42.....	Fargo
43.....	Rockford
44.....	Twin Cities
45.....	Davenport
51.....	Denver
52.....	Des Moines
53.....	Kansas City
54.....	Omaha
55.....	St. Louis
61.....	Dallas
62.....	Houston
63.....	Memphis
64.....	New Orleans
65.....	Oklahoma City
71.....	Los Angeles
72.....	San Jose
73.....	Salt Lake City
74.....	Seattle
81.....	Ford of Canada
83.....	Government
84.....	Hone Office Reserve
85.....	American Red Cross
86.....	Diplomatic Service Comm.
89.....	Transportation Services
90-99.....	Export

TRANSMISSION CODE

Code	Description
N.....	5-Speed Spicer 5652 Direct
P.....	5-Speed Spicer 5756-B Direct
Q.....	5-Speed Spicer 6352 Direct (Iron)
4.....	5-Speed Spicer 6354 Direct (Alum.)
U.....	5-Speed Spicer 6352-B Direct (Iron)
8.....	5-Speed Spicer 6354-B Direct (Alum.)
V.....	5-Speed Spicer 6452-A Direct (Iron)
7.....	5-Speed Spicer 6454-A Direct (Alum.)
S.....	5-Speed Spicer 6453-A Overdrive (Iron)
5.....	5-Speed Spicer 6455-A Overdr. (Alum.)
R.....	5-Speed Spicer 6852-G Direct (Iron)
6.....	5-Speed Spicer 6854-G Direct (Alum.)
X.....	5-Speed Fuller 5-H-74 Direct

Code	Description
B.....	5-Speed Spicer 8051-C Overdr. (Iron)
Y.....	5-Speed Spicer 8055-C Overdr. (Alum.)
C.....	5-Speed Spicer 8052 Direct (Iron)
Z.....	5-Speed Spicer 8054 Direct (Alum.)
2.....	6-Speed Transmatic MT-40
3.....	6-Speed Transmatic MT-42
T.....	8-Speed Fuller R-46 Direct
D.....	10-Speed Fuller R-96 Direct (Iron)
E.....	10-Speed Fuller RA-96 Direct (Alum.)
I.....	10-Speed Fuller R-960 Overdrive (Iron)
G.....	10-Speed Fuller RA-960 Overdr. (Alum.)
O.....	12-Speed Spicer 8125 Overdrive (Alum.)

DISTRICT CODE

Code	District
11.....	Boston
12.....	Buffalo
13.....	New York

100% SATISFACTION GUARANTEED
BUY IT NOW!
 Click Here To Order

PayPal American Express Discover MasterCard VISA

TRUCK REGISTRATION RATINGS

Series	Model	GVW (lbs)
F-850	F-850	25,000
	F-851	20,000
	F-852	25,000
	F-853	27,000
	F-854	27,000
	F-855	27,000
	F-856	25,500
	F-857	27,500
	F-950	F-950
F-951		24,000
F-952		30,000
F-953		30,000
F-954		32,000
F-955		32,000
F-956		34,000
F-957		29,000
F-958		31,000
F-959		33,000
HT-850	J-850	41,000
	J-851	32,000
	J-852	45,000
	J-853	48,000
H-950	H-950	30,000
	H-951	24,000
	H-952	32,000
	H-953	34,000
CT-850	L-850	39,000
	L-851	27,000
	L-852	41,000
	L-853	43,000
	L-854	45,000
	L-855	49,000
CT-950	L-950	47,000
	L-951	30,000
	L-952	49,000
	L-953	53,000
N-850	N-850	25,000
	N-851	20,000
	N-852	25,000
	N-853	27,000
	N-854	27,000
	N-855	27,000
	N-856	25,500
	N-857	27,500
	*F-1000D	K-000
K-001		26,000
K-002		34,000
K-003		36,000
HT-1000D	Y-000	32,000
	Y-001	26,600
	Y-002	34,000
N-1000	N-000	32,000
	N-001	26,000
	N-002	34,000
	N-003	36,000
F-1000	F-000	32,000
	F-001	26,000
	F-002	34,000
	F-003	36,000
F-1100	F-010	38,000
	F-001	30,000
C-850	C-850	27,000
	C-851	20,000
	C-852	27,000
	C-853	27,000
	C-854	27,000
	C-855	27,500

Series	Model	GVW (lbs)
H-1000	H-000	30,000
	H-001	24,000
	H-002	32,000
	H-003	34,000
*N-1000D	R-000	32,000
	R-001	26,000
	R-002	34,000
	R-003	36,000
	R-004	27,500
NT-850	S-850	39,000
	S-851	27,000
	S-852	41,000
	S-853	43,000
	S-854	43,000
	S-855	45,000
NT-850D	W-850	43,000
	W-851	27,000
	W-852	39,000
	W-853	41,000
	W-855	49,000
*F-1100-D	K-010	38,000
	K-011	30,000
*T-850-D	U-850	39,000
	U-851	27,000
	U-852	41,000
	U-853	43,000
	U-854	45,000
	U-855	49,000
*F-950-D	K-950	28,000
	K-951	24,000
	K-952	30,000
	K-953	30,000
	K-954	32,000
	K-955	32,000
	K-956	34,000
	K-957	29,000
	K-958	31,000
	K-959	33,000
	K-960	25,500
	K-961	27,500
C-950	C-950	30,000
	C-951	24,000
	C-952	30,000
	C-953	32,000
	C-954	32,000
	C-955	34,000
	C-956	34,000
	C-957	31,000
C-958	33,000	
C-1000	C-000	32,000
	C-001	26,000
	C-002	34,000
	C-003	36,000
C-1100	C-010	36,000
	C-011	30,000
T-850	T-850	39,000
	T-851	27,000
	T-852	41,000
	T-853	43,000
	T-854	43,000
	T-855	45,000
T-950	T-950	47,000
	T-951	30,000
	T-952	49,000
	T-953	53,000
	T-954	55,000
	T-955	59,000
	T-956	65,000
T-957	75,000	

Series	Model	GVW (lbs)
N-950	N-950	28,000
	N-951	24,000
	N-952	30,000
	N-953	30,000
	N-954	32,000
	N-955	32,000
	N-956	34,000
	N-957	29,000
	N-958	31,000
	N-959	33,000
*N-950-D	R-950	28,000
	R-951	24,000
	R-952	30,000
	R-953	30,000
	R-954	32,000
	R-955	32,000
	R-956	34,000
	R-957	29,000
	R-958	31,000
	R-961	27,500
NT-950	S-950	47,000
	S-951	30,000
	S-952	49,000
	S-953	53,000
*NT-950-D	W-950	47,000
	W-951	30,000
	W-952	49,000
	W-953	53,000
*T-950-D	U-950	47,000
	U-951	30,000
	U-952	49,000
	U-953	53,000
*HT-950-D	A-950	41,000
	A-951	32,000
	A-952	45,000
	A-953	49,000
*N-1100-D	R-010	38,000
	R-011	30,000
N-1100	N-010	38,000
	N-011	30,000

*Diesel engines

REAR AXLE CODES

Code	Ratio and Rating
EATON 30 DP	
1D	7.75—32M*
2D	8.55—32M*
3D	6.43—32M*
4D	6.78—32M*
5D	7.17—32M*
6D	7.60—32M*
EATON 30 DS	
1C	4.63—32M*
2C	4.88—32M*
3C	5.57—32M*
4C	6.50—32M*
5C	7.17—32M*
6C	7.60—32M*
EATON 30 DTA	
1L	4.63/6.43—32M*
2L	4.88/6.77—32M*
3L	5.57/7.75—32M*
5L	6.14/8.54—32M*
6L	6.50/9.04—32M*
7L	7.17/9.77—32M*

*M—Pounds Capacity in Thousands

*Diesel engines

100% SATISFACTION GUARANTEED

BUY IT NOW!

Click Here To Order

PayPal American Express Discover MasterCard VISA

TRUCK REGISTRATION RATINGS (Continued)

REAR AXLE CODES (Continued)

Code	Ratio and Rating
EATON 34 DP	
1N.....	7.60—34M*
3N.....	8.38—34M*
4N.....	5.05—34M*
5N.....	5.60—34M*
6N.....	5.91—34M*
7N.....	6.21—34M*
8N.....	6.65—34M*
EATON 34 DS	
1F.....	4.56—34M*
2F.....	4.88—34M*
3F.....	5.57—34M*
4F.....	6.50—34M*
5F.....	7.17—34M*
6F.....	7.60—34M*
7F.....	4.11—34M*
8F.....	4.33—34M*
EATON 34 M	
1E.....	4.56—34M*
2E.....	5.85—34M*
3E.....	6.69—34M*
4E.....	7.80—34M*
6E.....	8.60—34M*
EATON 34 DTA	
W1.....	4.33/5.91—34M*
W2.....	4.56/6.21—34M*
W3.....	4.88/6.65—34M*
W4.....	5.57/7.60—34M*
W5.....	6.14/8.38—34M*
W6.....	6.50/8.87—34M*
W7.....	7.17/9.77—34M*
W8.....	4.11/5.61—34M*
EATON 30 D-3	
3S.....	4.63/5.53/6.43—32M*
4S.....	4.88/5.83/6.77—32M*
5S.....	5.57/6.66/7.75—32M*
6S.....	6.14/7.35/8.55—32M*
7S.....	6.50/7.77/9.04—32M*
EATON 34 D-3	
1T.....	4.11/4.86/5.61—34M*
2T.....	4.33/5.12/5.91—34M*
3T.....	4.56/5.39/6.21—34M*
4T.....	4.88/5.76/6.65—34M*
5T.....	5.57/6.59/7.60—34M*
6T.....	6.14/7.26/8.88—34M*
7T.....	6.50/7.68/8.87—34M*
EATON 38 D-3	
1U.....	4.11/4.86/5.61—38M*
2U.....	4.33/5.12/5.91—38M*
3U.....	4.56/5.39/6.21—38M*
4U.....	4.88/5.76/6.65—38M*
5U.....	5.57/6.59/7.60—38M*
6U.....	6.14/7.26/8.38—38M*
7U.....	6.50/7.63/8.87—38M*

Code	Ratio and Rating
EATON 42 DP	
13.....	7.60—44M*
23.....	8.38—44M*
EATON 38 DP	
18.....	7.60—38M*
38.....	8.38—38M*
48.....	5.05—38M*
58.....	5.60—38M*
68.....	5.91—38M*
78.....	6.21—38M*
98.....	6.65—38M*
EATON 28M	
1B.....	7.07—28M*
2B.....	7.79—28M*
4B.....	6.50—28M*
5B.....	7.17—28M*
EATON 22M	
1A.....	6.70—22M*
2A.....	7.79—22M*
EATON 1790-A-91A	
84.....	5.57—18.5M*
86.....	6.14—18.5M*
87.....	6.50—18.5M*
88.....	7.17—18.5M*
89.....	7.67—18.5M*
91.....	4.33—18.5M*
92.....	4.56—18.5M*
93.....	4.88—18.5M*
EATON 17800-01	
H1.....	4.33/5.91—18.5M*
H2.....	4.56/6.21—18.5M*
H3.....	4.88/6.65—18.5M*
H4.....	5.57/7.60—18.5M*
H6.....	6.14/8.38—18.5M*
H7.....	6.50/8.87—18.5M*
H8.....	7.17/9.77—18.5M*
EATON 1880-1	
K1.....	4.88—22M*
K2.....	5.57—22M*
K3.....	6.50—22M*
K4.....	7.17—22M*
K5.....	6.14—22M*
EATON 18802-3	
S1.....	4.88/6.65—22M*
S2.....	5.57/7.60—22M*
S3.....	6.50/8.87—22M*
S4.....	7.17/9.77—22M*
S5.....	4.33/5.91—22M*
S6.....	4.56/6.21—22M*
S7.....	6.14/8.38—22M*
EATON 1911	
M1.....	4.11—23M*
M2.....	4.33—23M*
M3.....	4.88—23M*
M4.....	5.43—23M*
M5.....	6.17—23M*
M6.....	6.67—23M*

Code	Ratio and Rating
EATON 1919	
N1.....	4.11—23M*
N2.....	4.33—23M*
N5.....	4.88—23M*
N6.....	5.43—23M*
N7.....	6.17—23M*
N8.....	6.67—23M*
EATON 19503	
U2.....	4.33/5.89—23M*
U3.....	4.88/6.63—23M*
U4.....	5.43/7.39—23M*
U5.....	6.14/8.36—23M*
U6.....	6.71/9.13—23M*
EATON 19801	
V2.....	4.33/5.89—23M*
V3.....	4.88/6.63—23M*
V4.....	5.43/7.39—23M*
V5.....	6.14/8.36—23M*
V6.....	6.71/9.13—23M*
EATON 9503	
N3.....	5.89—23M*
N4.....	6.63—23M*
EATON 8802-3	
J1.....	5.91—22M*
J2.....	6.65—22M*
J3.....	6.21—22M*
EATON 1911	
MA.....	4.11—34M*
MB.....	4.33—34M*
MC.....	4.88—34M*
MO.....	5.43—34M*
ME.....	6.17—34M*
MF.....	6.67—34M*
EATON 1919	
NA.....	4.11—34M*
NB.....	4.33—34M*
NE.....	4.88—34M*
NF.....	5.43—34M*
NG.....	6.17—34M*
NH.....	6.67—34M*
EATON 19801	
VB.....	4.33/5.89—34M*
VC.....	4.88/6.63—34M*
VD.....	5.43/7.39—34M*
VE.....	6.14/8.36—34M*
VF.....	6.71/9.13—34M*
EATON 19503	
UB.....	4.33/5.89—34M*
UC.....	4.88/6.63—34M*
UD.....	5.43/7.39—34M*
UE.....	6.14/8.36—34M*
UF.....	6.14/8.36—34M*
TIMKEN R-171-P	
80.....	4.11—18.5M*
81.....	4.33—18.5M*
82.....	4.63—18.5M*
83.....	5.29—18.5M*
85.....	6.14—18.5M*

*M—Pounds Capacity in Thousands

*M—Pounds Capacity in Thousands

100% SATISFACTION GUARANTEED

BUY IT NOW!

Click Here To Order

PayPal American Express Discover MasterCard VISA

REAR AXLE CODES (Continued)

Code	Ratio and Rating
TIMKEN Q246P	
L1	4.92—22M*
L2	5.63—22M*
L3	6.39—22M*
L4	7.27—22M*
L5	6.04—22M*
TIMKEN Q346-P	
T1	4.92/6.76—22M*
T2	5.63/7.73—22M*
T3	6.39/8.78—22M*
T4	7.33/10.07—22M*
T5	6.00/8.24—22M*
TIMKEN R141-P	
φ1	4.11—23M*
φ2	4.33—23M*
φ3	4.63—23M*
φ4	5.29—23M*
φ5	5.57—23M*
φ6	6.14—23M*
φ7	6.83—23M*
TIMKEN RT-241P	
P1	4.62—23M*
P2	4.99—23M*
P3	5.46—23M*
P4	6.10—23M*
P5	7.21—23M*
TIMKEN RT-341P	
X1	4.62/5.91—23M*
X2	4.99/6.37—23M*
X3	5.27/6.74—23M*
X4	6.10/7.79—23M*
X5	6.91/8.83—23M*
TIMKEN R-202P	
Q1	4.41—23M*
Q2	4.77—23M*
Q3	5.54—23M*
Q6	6.26—23M*
Q7	7.09—23M*
TIMKEN R-302P	
Y1	4.41/5.64—23M*
Y2	4.89/6.23—23M*
Y3	5.54/7.09—23M*
Y4	6.42/8.38—23M*
Y5	7.09/9.07—23M*
TIMKEN U200	
R1	6.38—29M*
R2	7.03—29M*
R3	7.79—29M*
R4	5.91—29M*
TIMKEN U300	
Z1	6.42/8.38—29M*
Z2	7.09/9.07—29M*
Z3	5.54/7.09—29M*

Code	Ratio and Rating
TIMKEN SLHD	
1H	4.63—34M*
2H	5.29—34M*
3H	5.83—34M*
4H	6.83—34M*
5H	7.80—34M*
6H	8.60—34M*
TIMKEN SLHD (W/Lt. Wt. Susp.) (Aluminum)	
AH	4.63—34M*
BH	5.29—34M*
CH	5.83—34M*
DH	6.83—34M*
EH	7.80—34M*
FH	8.60—34M*
TIMKEN SLHD (W/Lt. Wt. Susp.) (MALLEABLE)	
AQ	4.63—34M*
BQ	5.29—34M*
CQ	5.83—34M*
DQ	6.83—34M*
EQ	7.80—34M*
FQ	8.60—34M*
TIMKEN SQHD	
19	4.63—38M*
39	5.29—38M*
49	5.83—38M*
59	6.83—38M*
69	7.80—38M*
79	8.60—38M*
TIMKEN SQHD (W/Lt. Wt. Susp.) (MALLEABLE)	
AR	4.63—38M*
CR	5.29—38M*
DR	5.83—38M*
ER	6.83—38M*
FR	7.80—38M*
GR	8.60—38M*
TIMKEN SQDD	
11	7.54—38M*
21	8.31—38M*
TIMKEN R-141P	
φA	4.11—34M*
φB	4.33—34M*
φC	4.63—34M*
φD	5.29—34M*
φE	5.57—34M*
φF	6.14—34M*
φG	6.83—34M*
TIMKEN R-202P	
QA	4.41—34M*
QB	4.77—34M*
QC	5.54—34M*
QF	6.26—34M*
QG	7.09—34M*
TIMKEN RT-341-P	
XA	4.62/5.91—34M*
XB	4.99/6.37—34M*
XC	5.27/6.74—34M*
XD	6.10/7.79—34M*
XE	6.91/8.83—34M*

Code	Ratio and Rating
TIMKEN R-302P	
YA	4.41/5.64—34M*
YB	4.89/6.23—34M*
YC	5.54/7.09—34M*
YD	6.42/8.38—34M*
YE	7.09/9.07—34M*
TIMKEN SRDD	
14	7.54—44M*
24	8.31—44M*
TIMKEN SUDD	
15	7.98—50M*
25	9.00—50M*
TIMKEN SFDD	
16	8.07—60M*
26	9.03—60M*
36	10.16—60M*

FRONT AXLE CODES

When required, the front axle code will be embossed directly in back of the rear axle code (Fig. 1).

Code	Capacity
A	5.5M*
B	12M*
C	5M*
D	6M*
E	7M*
F	9M*
G	11M*
H	15M*
O	9M*†
U	6M*†

*M—Pounds Capacity in Thousands
†—Heavy Duty Front Brakes

*M—Pounds Capacity in Thousands

100% SATISFACTION GUARANTEED

BUY IT NOW!

Click Here To Order

PayPal American Express Discover MasterCard VISA

GROUP 2—BRAKES

The 1964 maintenance recommendations are in Group 19, and the 1964 Specifications are in Group 23 of this manual.

All the service procedures outlined in Group 9 of the 1961 Ford Truck Shop Manual, 850-1100 Series, and in Group 9 of the 1962-63 Ford Truck Shop Manual Supplement, 850-1100 Series, remain the same with the following exceptions.

COMPRESSOR GOVERNOR

DESCRIPTION AND OPERATION

The governor (Fig. 1), operating in conjunction with the compressor unloading mechanism, automatically controls the air pressure in the air brake or air supply system between the desired, predetermined maximum and minimum pressures. The compressor runs continually while the engine runs, but the actual compression of air is controlled by the governor which stops or starts compression when the maximum or minimum reservoir pressures are reached. The D-2 governor has a piston upon which air pressure acts to overcome the pressure setting spring and con-

trol the inlet and exhaust valve to either admit or exhaust air to or from the compressor unloading mechanism.

Connections in this system are to the reservoir and compressor unloading ports. There also is an exhaust port.

Reservoir air pressure enters the D-2 governor at one of its reservoir ports and acts on the area of the piston and beneath the inlet and exhaust valve. As the air pressure builds up, the piston moves against the resistance of the pressure setting spring. The piston and inlet and exhaust valve move up when the reservoir air pressure reaches the cut-out setting of the governor.

The exhaust stem seats on the inlet and exhaust valve and then the inlet passage opens. Reservoir air pressure then flows by the open inlet valve, through the passage in the piston, and out the unloader port to the compressor unloading mechanism. The air, besides flowing to the compressor unloading mechanism, also flows around the piston and acts on the additional area of the piston. This additional force, which results from a larger area on the pis-

ton, assures a positive action and fully opens the inlet valve.

As the system reservoir air pressure drops to the cut-in setting of the governor, the force exerted by the air pressure on the piston is reduced so that the pressure setting spring moves the piston down. The inlet valve closes and the exhaust opens. With the exhaust open, the air in the unloader line escapes back through the piston, through the exhaust stem and out the exhaust port.

TWO-CYLINDER BRAKE SHOE—FRONT

REMOVAL

1. Raise the truck until the wheels clear the floor. Remove the wheel, and then remove the drum or the hub and drum assembly. **Mark the hub and drum to aid assembly in the same position.**

On a truck equipped with a vacuum or air booster, be sure the engine is stopped and there is no vacuum or air pressure in the system before disconnecting the hydraulic lines.

2. Remove both brake shoe return springs, (Fig. 2) using brake spring pliers.

3. Remove the C-washer and the flat washer from the adjusting cam and hold down stud. Lift the shoes off the backing plate.

INSTALLATION

1. Install the anti-rattle spring washer on each cam and shoe guide stud, with the pronged side facing the adjusting cam.

2. Place a shoe assembly on the backing plate with the cam and shoe guide stud inserted through the hole in the shoe web. Locate the shoe toe in the wheel cylinder piston shoe guide and position the shoe heel in the slot in the anchor block.

3. Install the flat washer and the C-washer on the cam and shoe guide stud. Crimp the ends of C-washer together.

4. After installing both shoes, install the brake shoe return springs (Fig. 2). To install each spring, place the spring end with the short hook in the toe of the shoe; then, using brake spring pliers, stretch the spring and secure the long hook end in the heel of the opposite shoe.

5. Install the hub and brake drum assembly.

6. Adjust the brakes.

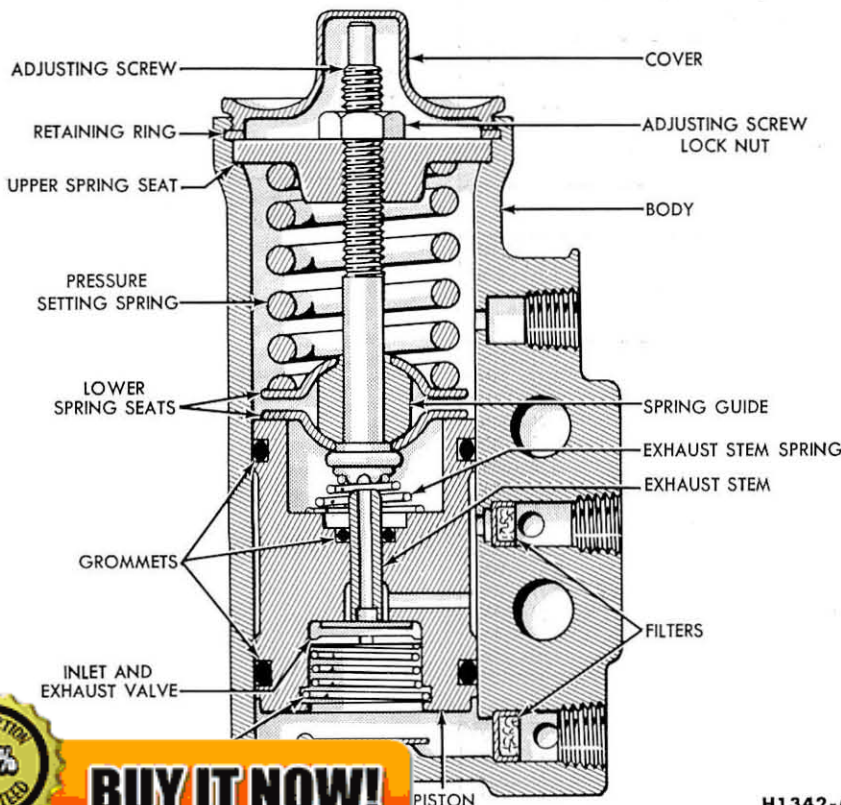

H1342-A

100% SATISFACTION GUARANTEED

BUY IT NOW!

Click Here To Order

PayPal, American Express, Discover, MasterCard, VISA

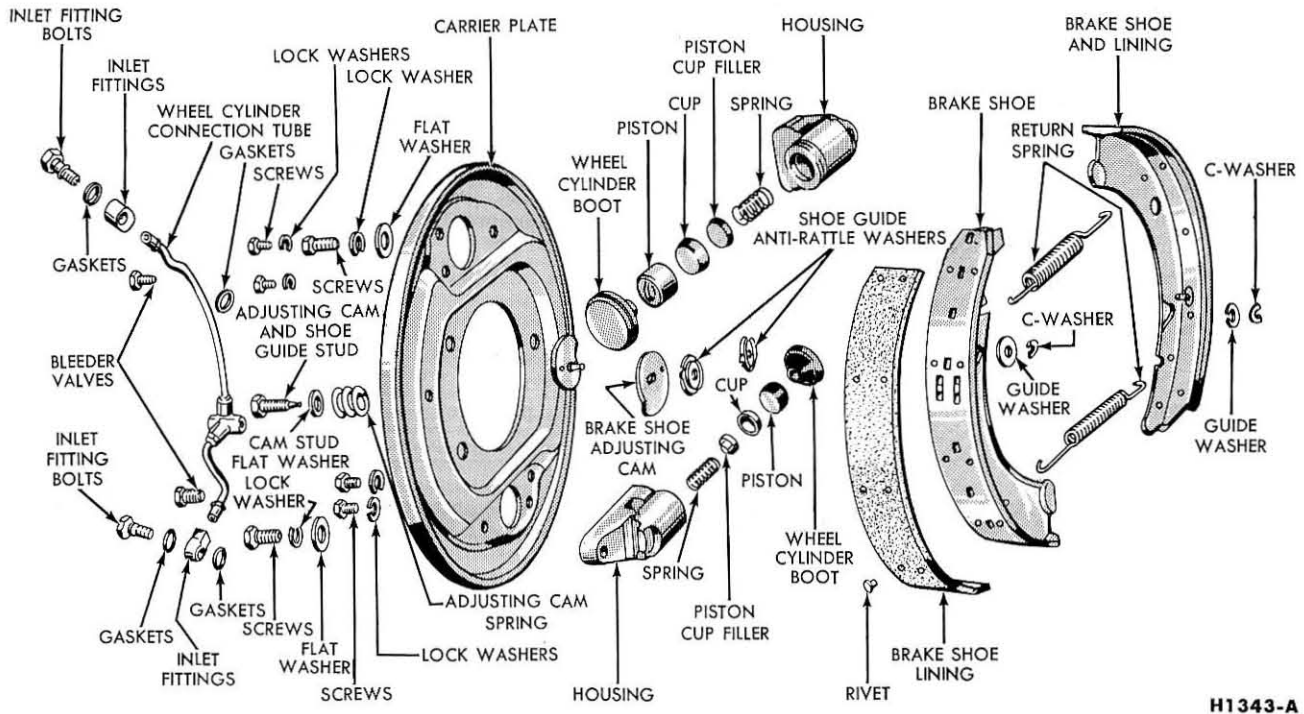

H1343-A

FIG. 2—Two-Cylinder Brake—Front

AIR BRAKES

The braking system consists of the foot control valve, the four brake chambers and slack adjusters, and two quick releasing valves. The distance the brake treadle is depressed regulates the amount of compressed air delivered by the foot control valve to the brake chambers. The amount of air, in turn, determines the braking force applied by the slack adjusters to the shoes. The design of the foot control valve has been slightly changed for 1964 (Fig. 3).

FOOT CONTROL VALVE OPERATION

APPLYING POSITION

Depressing the treadle forces the plunger, rubber graduating spring, and piston downward against the resistance of the return spring (Fig. 3). As the piston moves down against the exhaust seat, it closes the passage between the brake chamber ports and the exhaust port. Further downward movement of the piston forces the inlet-exhaust valve from the inlet seat (Fig. 3) to open the passage between reservoir pressure ports and the

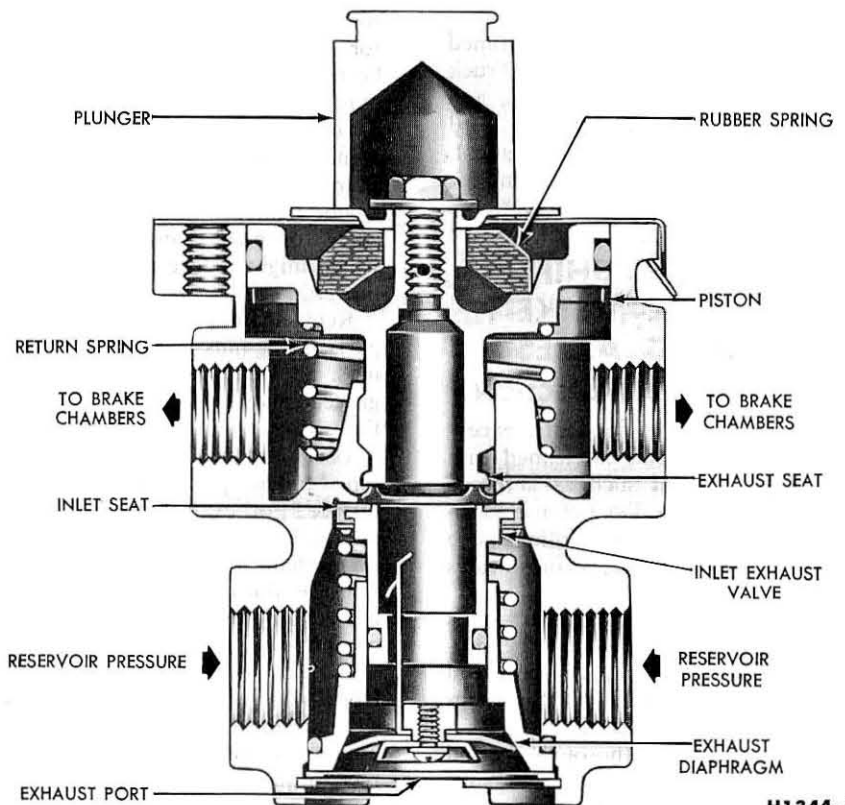

H1344-A

FIG. 3—Foot Control Valve Operation

100% SATISFACTION GUARANTEED

BUY IT NOW!

[Click Here To Order](#)

sure being delivered to the brake chambers equals the mechanical force on top of the piston, the piston lifts and the inlet valve closes, cutting off any further flow of air from the reservoir pressure ports through the valve body. The exhaust valve remains closed, however, because the mechanical pressure at the treadle holds the piston (seat) down against the valve. With both valves closed no more air can enter and the air already admitted can not escape. The valve is thus in balanced position.

If the treadle is depressed further,

mechanical pressure overcomes air pressure in the cavity beneath the piston opening the inlet valve again. This permits more reservoir air to enter until the pressure below the piston equals the mechanical pressure above and the inlet valve closes again. Complete depression of the treadle releases full reservoir pressure to the brake chambers.

RELEASED POSITION

If the treadle is partially released, air pressure beneath the piston overcomes the mechanical pressure

above, raising the piston and the inlet-exhaust valve assembly. This action closes the intake valve and opens the exhaust valve allowing air pressure from the brake chambers and lines to be released through the exhaust port. The air continues to exhaust until air pressure below the piston equals the mechanical pressure above. The foot control valve is again in balanced position. If the treadle is allowed to return to the fully released position, the exhaust valve remains open to exhaust all air from the chambers and fully release the brakes.

GROUP 3—SUSPENSION, STEERING, WHEELS AND TIRES

The 1964 maintenance recommendations are in Group 19, and the 1964 Specifications are in Group 23 of this manual.

The service procedures in Groups 7 and 8 of the 1961 Ford Truck Shop Manual, 850-1100 Series, and in Groups 7 and 8 of the 1962-63

Ford Truck Shop Manual Supplement, 850-1100 Series, remain the same for 1964.

GROUP 4—REAR AXLES

The 1964 maintenance recommendations are in Group 19, and the 1964 specifications are in Group 23 of this manual.

All the service procedures outlined in Group 6 of the 1961 Ford Truck Shop Manual, 850-1100 Series, and in Group 6 of the 1962-63 Ford Truck Shop Manual Supplement, 850-1100 Series, remain the same for 1964 with the following exceptions:

ELECTRIC SHIFT CONTROL—TIMKEN 2-SPEED AXLES

CLEANING AND INSPECTION

All shift unit components, except the shift motor, can be cleaned with a suitable solvent such as kerosene or diesel fuel oil. Do not use gasoline, water or alkaline solutions such as sodium hydroxide, orthosilicates and phosphates.

Completely assembled shift units may be steam cleaned, on the outside only, to facilitate removal and disassembly, provided all openings sealed.

Parts that have been cleaned, dried, inspected and are to be immediately assembled should be coated with light oil to prevent corrosion. If these parts are to be stored for any length of time, they should be treated with a good rust preventive and wrapped in a special paper or other material designed to prevent corrosion.

Inspect the oil seal to make sure it is not damaged. Check the electric leads for cracks and other defects which might reduce the efficiency of the unit.

Replace all worn or damaged parts. Hex nuts with rounded corners, all lock washers, oil seals and gaskets should be replaced at the time of overhaul.

Use only genuine Timken-Detroit replacement parts for satisfactory service. For example, using gaskets of foreign material generally leads to mechanical trouble due to variations in thickness and the inability of certain materials to withstand compression, oil, etc.

Remove nicks, mars and burrs from machined or ground surfaces. Threads must be clean and free to obtain accurate adjustment and correct torque. A fine mill file or India stone is suitable for this purpose. Studs must be tight prior to assembling the parts.

DESCRIPTION AND OPERATION

The new Rockwell Standard (Timken) shift unit consists of an electric motor, a worm shaft and wheel, an eccentric, and a connecting rod (Fig. 1).

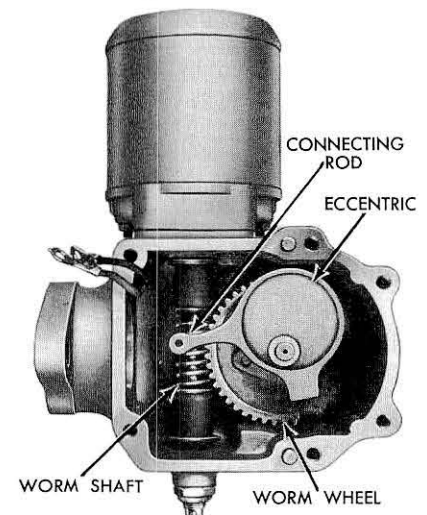

E1450-A

FIG. 1—Electric Shift Unit—Assembled View—Neutral Position

The electric motor drives the worm shaft, wheel and eccentric (Fig. 1). The connecting rod connects the eccentric to the shift shaft which

100% SATISFACTION GUARANTEED

BUY IT NOW!

Click Here To Order

PayPal American Express Discover MasterCard VISA

operates the push rod and shift collar (Fig. 11).

REMOVAL AND INSTALLATION

REMOVAL

1. Disconnect the wires from the terminals on the shift unit cover.

2. Remove the retaining screws and filler plug from the cover.

3. Turn a threaded tool into the filler plug hole as shown in Fig. 2, and pull the cover from the housing. The tool can be made by welding a $\frac{1}{8}$ x 27 pipe plug to the end of a T-handle.



FIG. 2—Electric Shift Unit Cover Removal

Do not pry the cover from the housing. Remove the cover to housing gasket.

4. Drive the roll pin from the shift shaft and eccentric connecting rod as shown in Fig. 3. The tool shown in Fig. 3 has a $\frac{5}{8}$ -inch body and a $\frac{5}{32}$ -inch nose section.

If the roll pin is in line with the worm shaft as shown in the insert of Fig. 4, it will be necessary to change the position of the shift shaft before the pin can be driven out.

To change the position of the shift shaft, turn on the ignition. Shift the unit to the desired position by touching the hot lead of the electric harness to the appropriate terminal on the shift unit cover. It is not necessary to attach the cover to the housing.

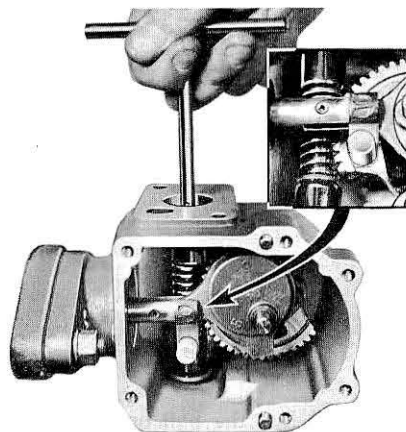

FIG. 4—Changing Position of Shift Shaft

If the shift motor is not operating, disconnect the wires at the inside face of the cover and remove the shift motor (Fig. 8). Install a new motor, and shift the unit to the desired position.

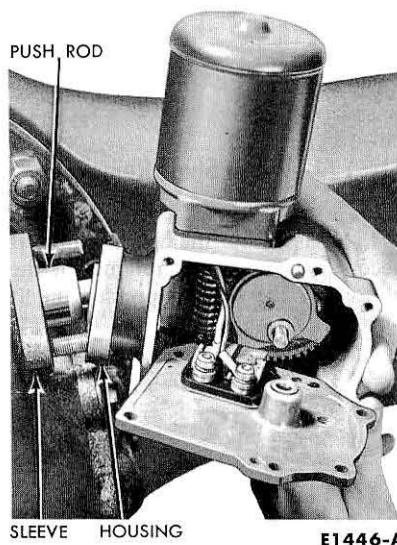

FIG. 5—Shift Unit Removal or Installation

In case a new motor is not available, use a slotted tool that fits over the tang of the worm shaft and turn it until the shift shaft changes position (Fig. 4).

5. Remove the nuts and lock washers from the mounting studs, and remove the shift unit from the carrier (Fig. 5). **Do not damage the oil seal in the flange.**

INSTALLATION

1. If a new shift unit is being installed, remove the cover from the housing with the tool shown in Fig. 2 as described in step 3 under "Removal".

2. Install a new shift unit housing to sleeve gasket, and position the shift unit over the mounting studs (Fig. 5). **Do not damage the oil seal that is installed in the flange section of the shift unit housing.**

3. As the shift unit is moved into place, move the eccentric connecting rod into the slot in the end of the shift shaft (Fig. 6). Install the lock washers and mounting stud nuts, and torque to specifications.

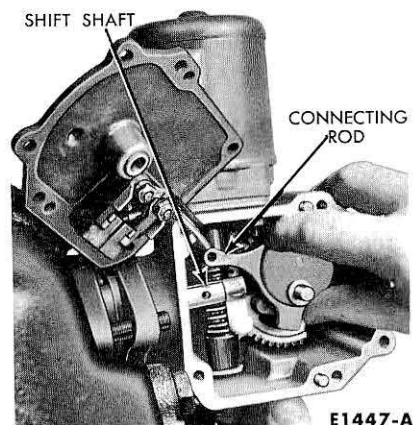

FIG. 6—Positioning Connecting Rod in Shift Shaft

4. Align the hole in the connecting rod with the hole in the shift shaft, and drive the roll pin into place with a suitable driver as shown in Fig. 7. The driver shown has a hole in one end, $\frac{3}{16}$ -inch diameter by $\frac{1}{4}$ -inch deep, to hold the pin at the beginning.

5. When installing the shift unit cover, the shift unit and axle assembly must be in the neutral position to avoid damaging the switches. Install the gasket and cover, and secure with retaining screws.

6. Fill the unit to the bottom of the filler hole with SAE 10 engine oil. Install the filler plug.

7. Connect the wires from the electric harness to the terminals on the outside of the shift unit cover. The red wire should be connected

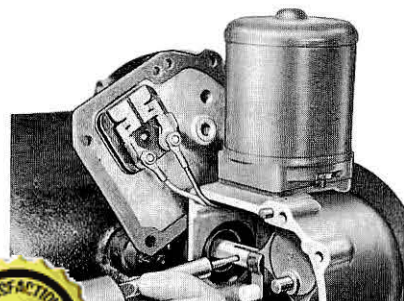

BUY IT NOW!

Click Here To Order



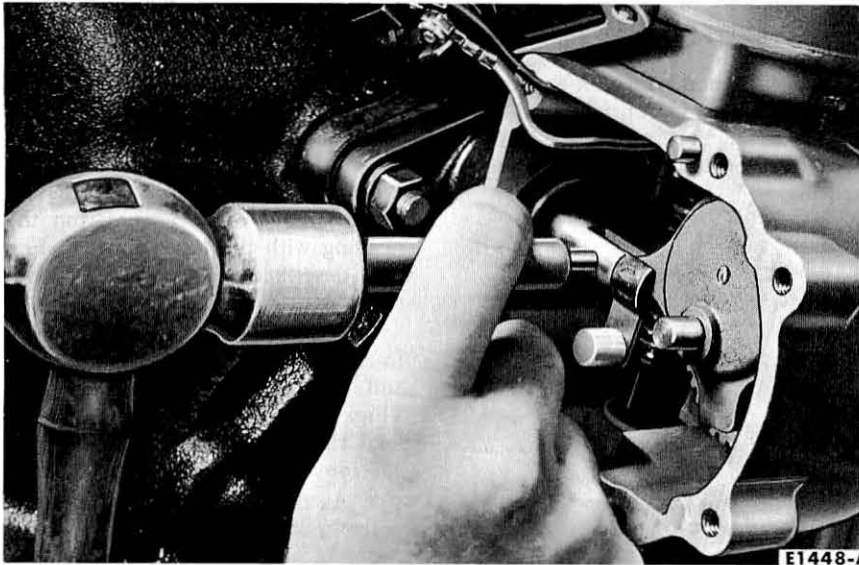

FIG. 7—Roll Pin Installation

to the terminal nearest to the mounting flange of the shift unit. The black wire connects to the other terminal.

MAJOR REPAIR OPERATIONS DISASSEMBLY

1. Disconnect the wires from the terminals on the inside face of the housing cover (Fig. 3).

2. Remove the two stud nuts and star washers that hold the shift motor to the shift housing (Fig. 8), and



FIG. 8—Shift Motor Removal or Installation

ful not to lose the ball bearing that rides in the recess of the adjusting screw (Fig. 9).

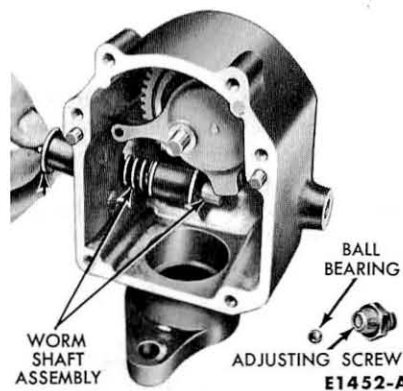

FIG. 9—Worm Shaft Removal

4. Disassemble the worm shaft, if necessary. The spring retainer at the bottom of the shaft is pressed on. It

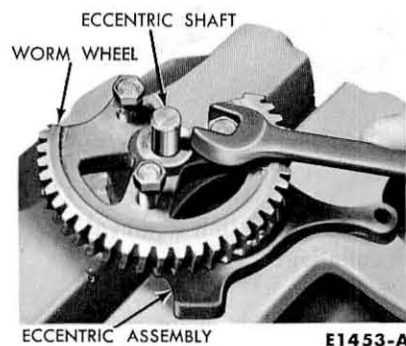

FIG. 10—Worm Wheel and Eccentric Components

can be removed by holding it in a vise and driving out the shaft.

5. Remove the worm wheel and eccentric assembly from the housing. While holding the assembly in a vise, remove the cap screws and lock washers and drive the eccentric shaft out of the assembly (Fig. 10).

ASSEMBLY

1. Assemble the worm, springs, spring washers, and thrust washer to the worm shaft and press on the lower spring retainer (Fig. 11). Position the worm shaft assembly in the shift housing.

2. Position the gasket, and install the shift motor to the shift housing so that the slot in the motor shaft fits over the tang of the worm shaft (Fig. 8).

3. Install the two star washers and stud nuts that hold the motor to the housing.

4. Place the ball bearing in the recess of the adjusting screw, and turn in the adjusting screw until the ball bearing is snug against the end of the worm shaft assembly (Fig. 12). Back off the adjusting screw $\frac{1}{8}$ turn for proper adjustment.

5. Hold the adjusting screw in place, and tighten the lock nut to secure the adjustment. Check to see that the worm shaft turns freely by hand.

6. Position the worm wheel at the inner side of the eccentric. Place the connecting rod and cover on the outer side (Fig. 11). While holding these components in a vise, fasten them together by driving the eccentric shaft through the assembly (Fig. 10). The shaft should protrude an equal distance from each side of the assembly. Install the cap screws and lock washers.

7. Install the eccentric and worm wheel assembly in the shift housing.

8. Connect the motor wires to the terminals on the inside face of the shift cover. Attach the red wire to the terminal nearest to the flange of the shift unit.

THREE-SPEED TANDEM DRIVE AXLE

DIAGNOSIS AND TESTING CIRCUIT BREAKER OPERATION CHECK

Disconnect the circuit breaker lead wire from terminal "A" (Fig. 13). Connect a 12-volt test lamp across terminal "A" and ground it on the vehicle frame. Turn on the ignition switch (or accessory switch for diesel

100% SATISFACTION GUARANTEED

BUY IT NOW!

Click Here To Order

PayPal American Express Discover MasterCard VISA

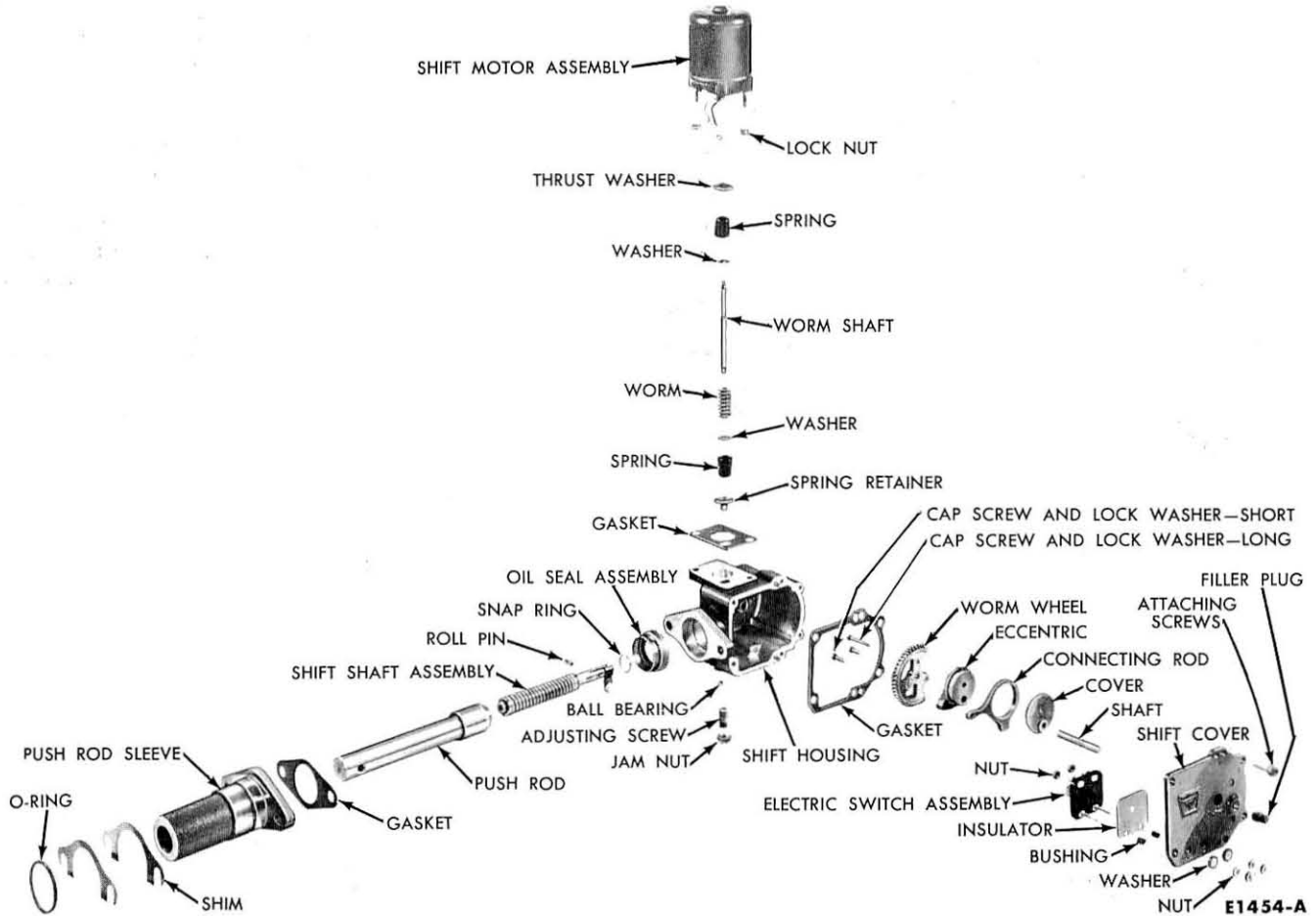

FIG. 11—Shift Unit Disassembled

engines) and observe the test lamp operation.

1. If the lamp lights and stays on continuously, the circuit breaker and the lead wire are satisfactory.

2. If the lamp does not light, check for poor electrical connections or broken lead wire. If the lead wire and electrical connections are satisfactory, the circuit breaker is faulty.

3. If the lamp does not light immediately then starts to flash on and off (also a faint clicking of the circuit breaker may be heard), the circuit breaker is faulty.

CONTROL SWITCH AND WIRING HARNESS CHECK

1. If trouble in the control switch or wiring harness is suspected, visually check as follows: Check the harness for damaged or worn insulation that may cause a ground connection, especially where the harness passes through the cab floor. Check for short circuits between the wire terminals.

2. To determine the condition of the control switch, it is recommended that a new control switch be tempor-

arily installed. However, if desirable, the control switch operation may be checked with a test lamp as follows:

Under actual installation conditions, the lead wires to the speedometer adapters could be transposed without affecting the operation. However, in the following tests, it is assumed that terminal "B" lead wire is connected to the black wire leading to the rear-rear axle solenoid valve, and terminal "C" lead wire is connected to the red wire leading to the forward-rear axle solenoid valve.

a. Disconnect the lead wires at the speedometer adapters, terminals "B" and "C", and at the solenoid valves, terminals "E" and "F". Turn the ignition switch on and alternately connect the test lamp leads to the disconnected lead wires. Operate the control switch and observe the test lamp for the following conditions:

(1) When the test lamp is connected to the speedometer adapter lead wire (terminal "B"), the lamp should light in the high range or "HI" position of the control switch. The lamp should go out with the control switch in the "INT" (intermediate

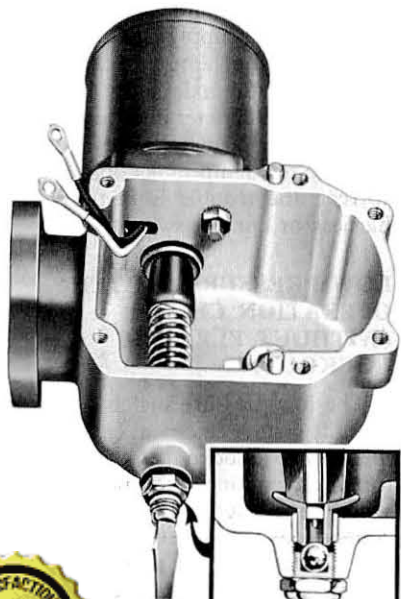

100% SATISFACTION GUARANTEED

BUY IT NOW!

Click Here To Order

PayPal, American Express, Discover, MasterCard, VISA

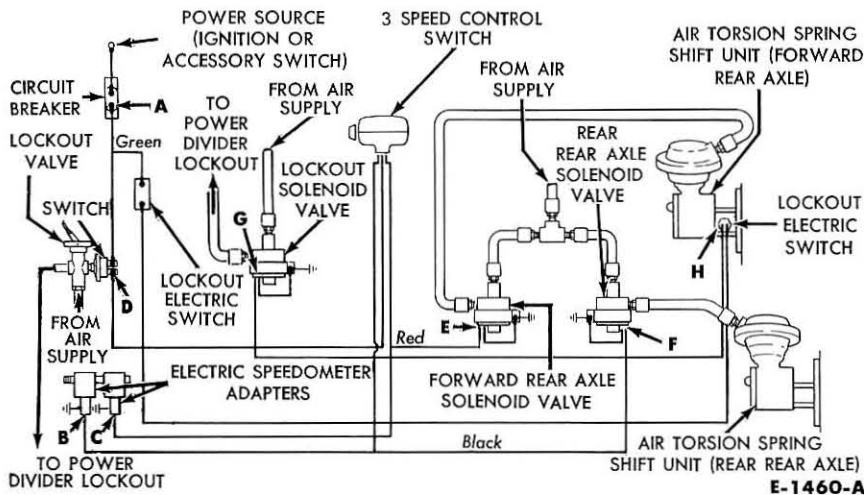

FIG. 13—Three-Speed Air-Torsion Spring Shift System

range) or "LO" (low range) position.

(2) When the test lamp is connected to the speedometer adapter lead wire (terminal "C"), the lamp should light in the high range or "HI" position and intermediate range or "INT" position. The lamp should go out with the control switch in the "LO" (low range) position.

(3) When the test lamp is connected to the solenoid valve lead wire (terminal "E"), the lamp should light in the intermediate range or "INT" position and high range or "HI" position of the control switch. The lamp should go out when the control switch is in the "LO" position.

(4) When the test lamp is connected to the solenoid valve lead wire (terminal "F"), the lamp should light in the high range or "HI" position of the control switch. The lamp should go out when the control switch is in the "INT" position or "LO" position of the control switch.

(5) If the test indications are correct in the above tests, current supply is correct to the speedometer adapters and the solenoid valves.

(6) If the lamp does not light correctly, the trouble may be a short circuit in the wiring harness or the control switch, or a wire in a harness may be broken.

SOLENOID VALVES OPERATION CHECK

One solenoid valve is energized supply air to the shift units in the

electric lockout, a third solenoid valve operates the lockout on the power divider. Each valve must have a good ground connection to the vehicle frame to operate satisfactorily. Before condemning a solenoid valve operation, make certain that the ground connection is satisfactory.

1. To check the solenoid valve operation, disconnect the lead wires at terminals "E", "F" and "G", and the air lines leading to the respective shift unit.

2. Install an air pressure gauge in the air line opening in the solenoid valve.

3. Apply a power supply (vehicle voltage) to the solenoid valve terminal and observe the pressure gauge reading. The operating pressure should approximate the reservoir pressure. If the gauge indicates approximate reservoir pressure, the solenoid valve operation is satisfactory. If the gauge indicates low or no pressure, the solenoid valve is faulty.

AIR-TORSION SPRING SHIFT UNIT OPERATION CHECK

If the electrical system is satisfactory and the axle does not shift satisfactorily, the trouble may be caused by a faulty air-torsion spring shift unit. Disassemble and repair a faulty shift unit.

SPEEDOMETER ADAPTER OPERATION CHECK

Two speedometer adapters are mounted together with one adapter being energized in the high axle range only while the other is energized in the intermediate axle range and high axle range. The adapters are grounded through the speedom-

eter mounting or the speedometer cable and cable housing. Before condemning speedometer adapter operation, make certain that the ground connection is satisfactory.

1. To test the speedometer adapter circuit with a test lamp, first disconnect the lead wire at terminal "B". It is assumed that the terminal "B" lead wire connects to the black wire leading to the rear rear axle solenoid valve.

2. Connect the test lamp to the terminal "B" lead wire and ground on the vehicle frame.

3. Turn the ignition switch on and observe the test lamp operation. The test lamp should light in the high range or "HI" position of the control switch. The lamp should go out when the control switch is placed in the "INT" or "LO" position.

4. To test the other speedometer adapter circuit with a test lamp, disconnect the lead wire at terminal "C". It is assumed that the terminal "C" lead wire connects to the red wire leading to the forward rear axle solenoid valve.

5. Connect the test lamp to the terminal "C" lead wire and ground on the vehicle frame.

6. Turn the ignition switch on and observe the test lamp operation. The test lamp should light in the intermediate range or "INT" position and high range or "HI" position of the control switch. The lamp should go out when the control switch is placed in the "LO" position.

If the lamp indications are correct, current supply to adapters is correct. If the lamp indications are correct and the axle shifts normally, but the speedometer does not operate properly, replace the faulty adapter.

If the test lamp indications are not correct, the trouble is in the wiring harness or control switch.

LOW PRESSURE SWITCH OPERATION CHECK (WITHOUT ELECTRIC LOCKOUT)

The low pressure switch opens the air shift system electrical circuit when the inter-axle lockout is engaged. Before condemning the low pressure switch operation, make certain the connections are satisfactory.

1. To test the low pressure switch, place the control switch in the "HI" position or high axle range.

2. Turn on the ignition switch, then engage the inter-axle differential lockout. Air should bleed from the shift system and the axles should

One solenoid valve is energized supply air to the shift units in the

100% SATISFACTION GUARANTEED

BUY IT NOW!

Click Here To Order

PayPal American Express Discover MasterCard VISA

shift to low range.

3. If this does not occur, check the low pressure switch circuit with a test lamp as follows:

(a) Disconnect the lead wire at terminal "D". Connect the test lamp to terminal "D" and ground it on the vehicle frame. Turn on the ignition switch. Place the lockout valve in the engaged and disengaged positions, and observe the test lamp operation.

(b) In the disengaged position, the test lamp should light. If the lamp does not light, check for a poor electrical connection or a broken lead wire. If the wire and connection are satisfactory, the low pressure switch is faulty.

(c) In the engaged position, the test lamp should not light. If the lamp lights, the low pressure switch is faulty.

ELECTRICAL SWITCH CHECK (AT SHIFT UNIT)

This electric switch opens in "HI" and "INT" and closes in the "LO" position of the control switch.

1. To check the switch, disconnect the lead wire at terminal "H".

2. Connect the test lamp to terminal "H" and ground.

3. Close the manual electric lockout switch and operate the control switch in all positions. The test lamp should light in the "LO" position and should not light in the "HI" and "INT" positions. Replace a faulty switch.

DESCRIPTION AND OPERATION

DESCRIPTION

The Eaton Three-Speed Tandem Drive Axle consists of two planetary-type, two-speed axle units, coupled with a power divider and an inter-axle differential.

One control switch, mounted on the gear shift lever, effects the speed changes. This manually-operated switch controls operation of an air-torsion spring shift system, which, in turn, shifts the axles from one ratio to the next.

OPERATION—SYSTEM

High Range. When the control switch is moved to the "HI" position or the axle range, current to the two solenoid valves allows air to pass from

push rod on each unit, which, in turn, move the spring winding levers. The spring winding levers increase the load placed on the torsion springs. When this occurs, the axles are ready to shift to high range. When torque on the gears is relieved by closing and opening the throttle, or declutching, the shift is completed.

Intermediate Range. When the control switch is moved to the "INT" position or the intermediate range, the solenoid valve shuts off the air supply to the rear-rear axle shift unit, and the solenoid valve for the forward-rear axle remains open, allowing the forward axle shift unit to retain its air. Thus, when torque on the gears is relieved by closing and opening the throttle, or declutching, the rear-rear axle is shifted to low range and the forward-rear axle remains in high range and the shift is now completed to intermediate.

Low Range. When the control switch is moved to "LO" position, or low range, both solenoid valves shut off the air supply. Air pressure in the air-torsion spring shift units bleeds back through the solenoid valves and air lines. Pressure on the diaphragm is released. The push rod moves toward the diaphragm and moves the spring winding lever. Additional load is placed on the torsion spring providing a condition ready for the axle to shift to the low range. When torque on the gears is relieved by closing and opening the throttle, or declutching, the shift to low range is completed.

OPERATION—COMPONENTS

Control Switch. The control switch is a three-position switch (Fig. 14) mounted on the gear shift lever and is manually operated by the driver.



E1461-A

FIG. 14—Three-Speed Control Switch

The switch controls current flow through the electrical system to operate the speedometer adapters and solenoid valves.

Speedometer Adapters. Two speedometer adapters are mounted in the system and compensate for drive shaft speed variations between low, intermediate and high speed axle range. In low range, the adapters are not energized. In intermediate range, one adapter is energized to a 1:1 ratio while the other adapter is not energized. In high range both adapters are energized to a 1:1 ratio. This arrangement is accomplished by connecting each adapter in parallel to one of each of the two solenoid valves in the system.

For systems that use the front wheel drive speedometer, the above mentioned speedometer adapters are not required in the electrical system.

Wiring Harness and Circuit Breaker. The electrical wiring in the system is a completely assembled unit including a circuit breaker. Individual wires in the harness are identified by various colors (Fig. 13). The circuit breaker is connected to the wire leading from the power source. If a short circuit occurs, the circuit breaker will open and cut off the electrical current to the system.

Solenoid Valves. Two solenoid valves provide the link between the electrical control system and the air-torsion spring shift units. When the solenoids are energized, air is allowed to travel to the air shift units and thus shift the axles. When the solenoid valves are de-energized, by movement of the control switch, the air pressure supply is shut off allowing the air-torsion spring shift units to bleed air through the solenoid valve exhaust port. In units with an electric lockout, an additional solenoid valve controls the air pressure supply to operate the lockout unit mounted on the power divider.

Lockout with Low Pressure Switch.

A low pressure switch is included in the shift system. This switch is mounted in the lockout valve and prevents the use of the inter-axle differential lockout except when the axles are in low ratio. When the lockout is engaged, this switch immediately allows the axles to go to low ratio, no matter what range they were in previously. With the lockout engaged, the axles cannot be shifted.



BUY IT NOW!

Click Here To Order



Lockout with Electric Switches. The electric type lockout consists of two electric switches and a solenoid valve (Fig. 13). One switch is located in the vehicle cab and the other is mounted on the forward-rear axle shift unit. This type system permits the lockout to engage in low range only. When the shift unit is in intermediate and high range position, the electric switch at the shift unit is open. This prevents completion of the electrical circuit to the lockout solenoid valve.

Air-Torsion Spring Shift Unit. The air-torsion spring shift unit is mechanically connected to the axle shift fork and shifts the axle. This unit includes an air chamber and a torsion spring drive assembly. A diaphragm, operated by air pressure, moves a push rod. The end of the push rod connects to a spring winding lever. This lever is part of the torsion spring drive assembly, which acts to move the shift fork and change the axle range.

IN-TRUCK ADJUSTMENTS AND REPAIR
SPEEDOMETER ADAPTER

The speedometer adapters are lubricated and sealed for the life of the unit. No maintenance is required. Replace a defective unit. It is not necessary to replace both units if only one has failed.

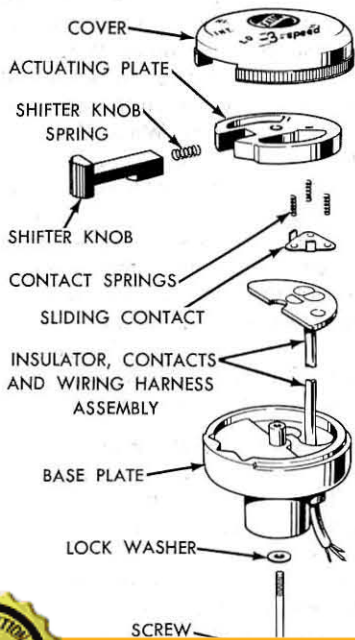

SOLENOID VALVE

Replace the solenoid valve as an assembly. The valve should not be serviced.

LOW PRESSURE SWITCH REPAIR (WITHOUT ELECTRIC LOCKOUT)

Replace the low pressure switch as an assembly. The switch is a sealed unit and cannot be serviced.

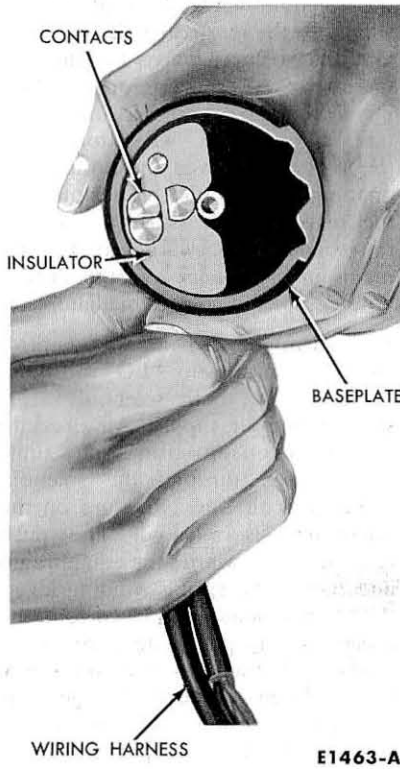

FIG. 16—Installing Wiring Harness in Base Plate

LOCKOUT SWITCH (AT SHIFT UNIT)

Replace the lockout switch as an assembly.

REPLACEMENT AND REPAIR
CONTROL SWITCH
Removal.

1. Disconnect the wires from the end of the control switch wiring harness.
2. Unscrew the switch from the gear shift lever.

Disassembly.

1. Remove the screw from the mounting side of the switch. Lift off the cover, actuating plate, shifter knob, knob spring, contact springs and contact (Fig. 15).

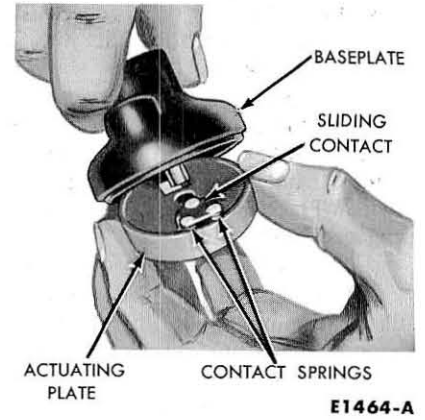

FIG. 17—Installing Actuating Plate on Base Plate

2. Remove the insulator, contacts and wiring harness assembly from the base plate.

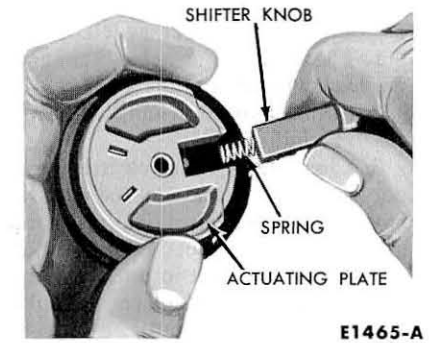

FIG. 18—Installing Shifter Knob

Inspection.

1. Inspect all parts for cracks or damage.
2. Inspect the contacts for a burned

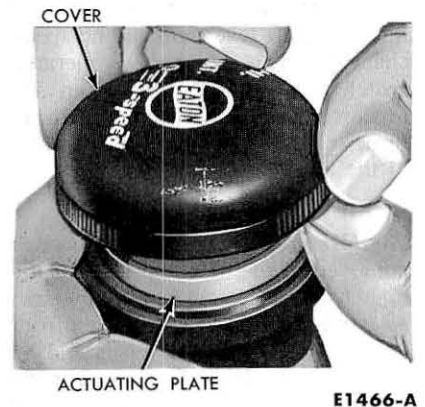

FIG. 19—Installing Cover

100% SATISFACTION GUARANTEED
BUY IT NOW!
Click Here To Order

or corroded condition.

3. Check for defective wiring connections.

4. Replace the individual parts if they are defective. Replace the insulator, contacts and wiring harness as an assembly.

Assembly.

1. Pass the wiring harness through the base plate, (Fig. 16) positioning the insulator in the recessed area

of the base plate.

2. At this point in assembly, lubricate the contacts and pivot hub (at center of base plate) with a light film of non-melting silicone grease.

3. Hold the actuating plate (top side down) in one hand and install three springs and the sliding contact in the correct mounting position (Fig. 17). Place the base plate over the actuating plate with the other hand.

4. Hold the actuating plate and the base plate together with one hand, then install the spring and the shifter knob. (Fig. 18).

5. Continue to hold the actuating plate in the mounting position and install the cover (Fig. 19). Fasten the cover to the base plate with a lock washer and screw.

6. Thread the control switch assembly on the gear shift lever. Connect the wiring harness (Fig. 13).

GROUP 5—DRIVE LINE AND CLUTCH

The 1964 maintenance recommendations are in Group 19, and the 1964 specifications are in Group 23 of this manual.

All service procedures in Groups 5 and 6 of the 1961 Ford Truck Shop Manual, 850-1100 Series, and the 1962-63 Ford Truck Shop Manual Supplement, 850-1100 Series, remain the same for 1964 with the following exceptions:

DRIVE LINE TROUBLE DIAGNOSIS

DRIVE LINE VIBRATION

The following procedure should be used to isolate the particular part or parts causing the problem when a vibration condition exists which is thought to be caused by drive line components:

1. Road test the truck to determine the critical vibration points. Note road speed, engine rpm, and shift lever positions at which the vibration occurs.

2. Stop the truck and run the engine with the clutch depressed through the critical speed ranges noted above. If excessive vibration is present, correct the engine or clutch

condition causing the problem. If the problem is not present, continue the diagnosis.

3. With the main transmission in neutral and the clutch engaged, run the engine through the critical speed ranges and note if any excessive vibration is apparent. If a problem is found to exist, check the transmission to clutch housing alignment and the clutch assembly for the cause of the problem.

4. Check the auxiliary transmission mounts. Pay particular attention to the proper location of the insulators and spacers, and the installation of the forward trunnion on the transmission case. If these parts are found not to be to specification, correct them and again run the engine through the critical speed ranges to determine if the vibration still exists. If the vibration is still present, check the flange angles of the main and auxiliary transmission and the coupling shaft. If these assemblies are not to specification, rework as necessary to obtain the required driveline angles.

5. Check for vibration by driving the main transmission and coupling shaft, keeping the auxiliary transmis-

sion in neutral. If excessive vibration is present, correct transmission alignment as necessary. If the problem is not present, continue the diagnosis.

6. Disconnect the inter-axle drive shaft. Engage the inter-axle lockout switch and then drive the engine and the drive line through the critical speed ranges. If vibration is present, the drive line forward of the bogie is at fault. If vibration is not apparent, the bogie drive line, its U-joints, and/or flange angles may be the cause of the problem. If the bogie drive line is at fault, check for the proper cross member location.

Avoid excessive operation with the inter-axle shaft locked out to prevent damage to the power divider.

7. Remove the main drive shaft and then drive the engine, the main, and the auxiliary transmissions through the critical speed ranges. If vibration is not present, the problem is caused by the main drive shaft or improper drive line angles between the auxiliary transmission (or main transmission if no auxiliary transmission is used) and the forward rear axle flange. To correct this, check the flange angles, the U-joints,

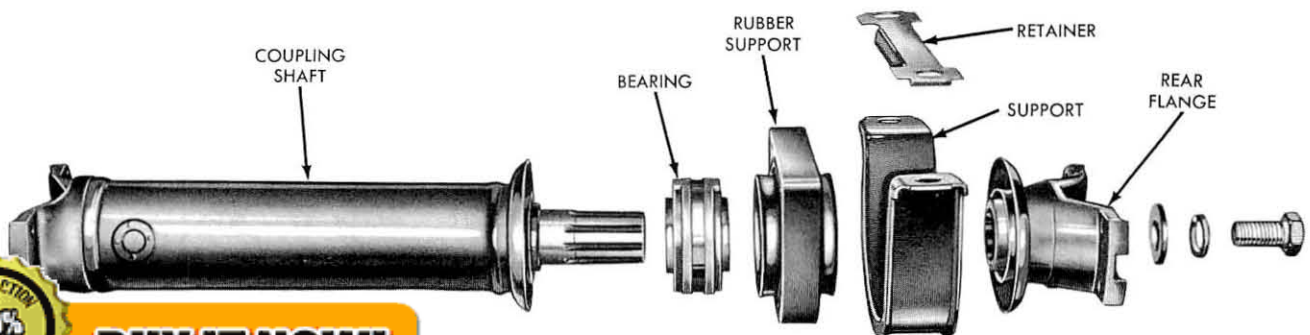

Support Bearing

E1169-A



BUY IT NOW!

Click Here To Order



and the main drive shaft angles.

If the problem cannot be isolated to a particular drive shaft, or if all drive line angles are to be checked, use a **spirit level protractor** and adjust the alignment as detailed on page 20.

DESCRIPTION AND OPERATION

The drive line is composed of the universal joints, connecting shafts, and the attaching flanges. The number of shafts and universal joints used depends on the truck wheelbase. The shorter wheelbase trucks use only the drive shaft portion of the drive lines and have a short sliding spline-type drive shaft with Mechanic type flanges.

The longer wheelbase trucks are equipped with one or more coupling shafts, which extend from the transmission to rubber-bushed center support bearings, and a drive shaft which extends from the center support to the rear axle (Fig. 1).

All the truck universal joint spiders and sliding splines are equipped with lubrication fittings. These spiders and splines should be lubricated periodically.

The center support bearings are pre-lubricated and sealed for the life of the bearing.

A T-Series truck equipped with an auxiliary transmission has a transmission to auxiliary transmission universal joint (Fig. 2) to transmit the power from the conventional transmission to the auxiliary transmission. This assembly consists of two close-coupled universal joints. The assembly may be replaced without removing either of the transmissions from the truck.

In the multiple shaft drive line installation, the slip joint is located in the drive shaft, or in the coupling shaft. Drive shafts and coupling shafts are balanced; therefore, if the truck is to be undercoated, cover the drive shaft to prevent getting undercoating material on the shaft.

All universal joints are of the needle bearing type. The universal joint bearings are retained on the universal joint spiders by bearing caps and bolts.

REPLACEMENT

UNIVERSAL JOINT REPLACEMENT

1. Bend the tangs of the lock plates away from the cap screws.

2. Remove the cap screws which attach the bearing caps to the universal joint flange and yoke. Remove the bearing caps and bearings from the spider.

3. Remove the grease seals, and retainers, from the spider.

4. To install, pack the recess in the spider with the recommended lubricant.

5. Install the grease seals on the spider.

6. Position the needle bearings in the bearing caps, then position the caps on the spider. Place the spider on the yokes, and then install the bearing cap locks.

7. Secure the locks to the yokes with the cap screws. Bend the tangs of the locks up against the cap screw heads.

TRANSMISSION TO AUXILIARY TRANSMISSION UNIVERSAL JOINTS

1. To replace the transmission to auxiliary transmission input shaft U-joint assembly (Fig. 2), remove the universal bearing cap bolts from the auxiliary transmission input shaft U-joint flange and the transmission output shaft U-joint flange.

2. After the universal joint assembly has been removed from the truck, separate the two universal joints by loosening and removing the dust cap, washers, and seal from the U-joint knuckles. Pull the assemblies apart.

3. Remove the bearing caps and spiders from their respective yokes.

4. Clean and inspect the spiders, bearings, and shields. Replace with

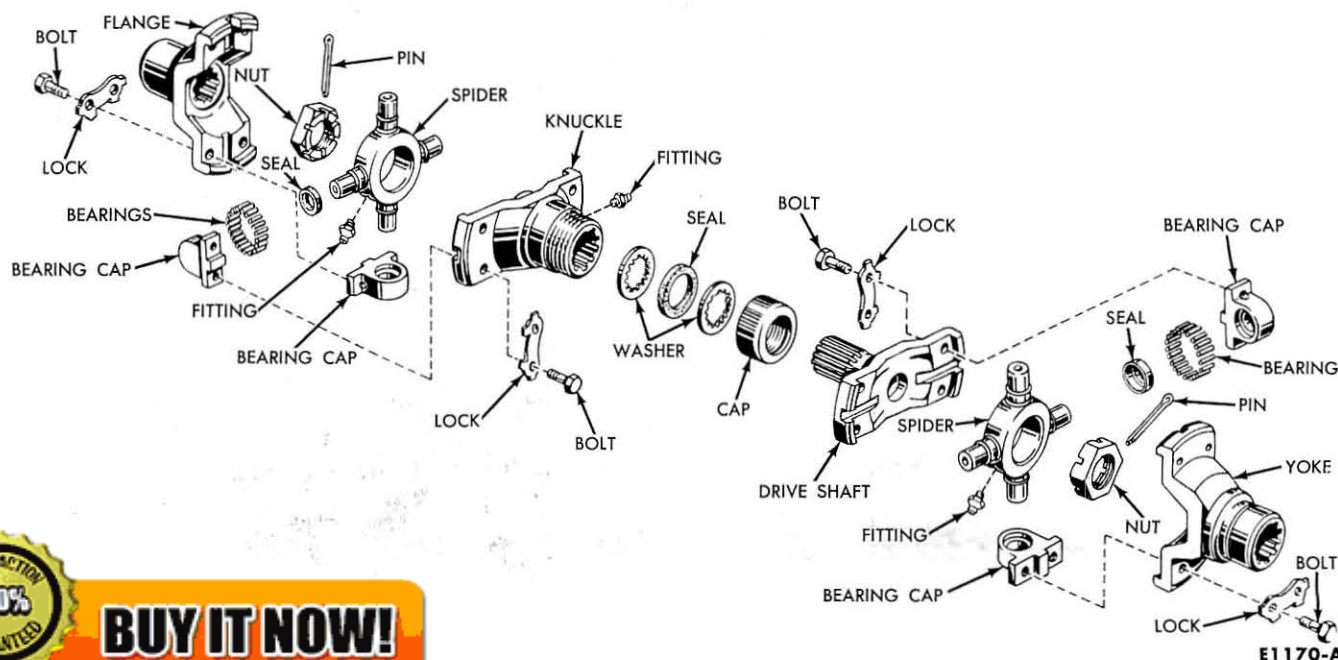

BUY IT NOW!

Click Here To Order

Universal Joints



FIG. 3—Universal Joint Flange and Yoke Alignment

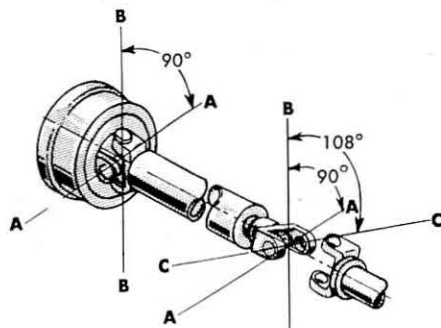
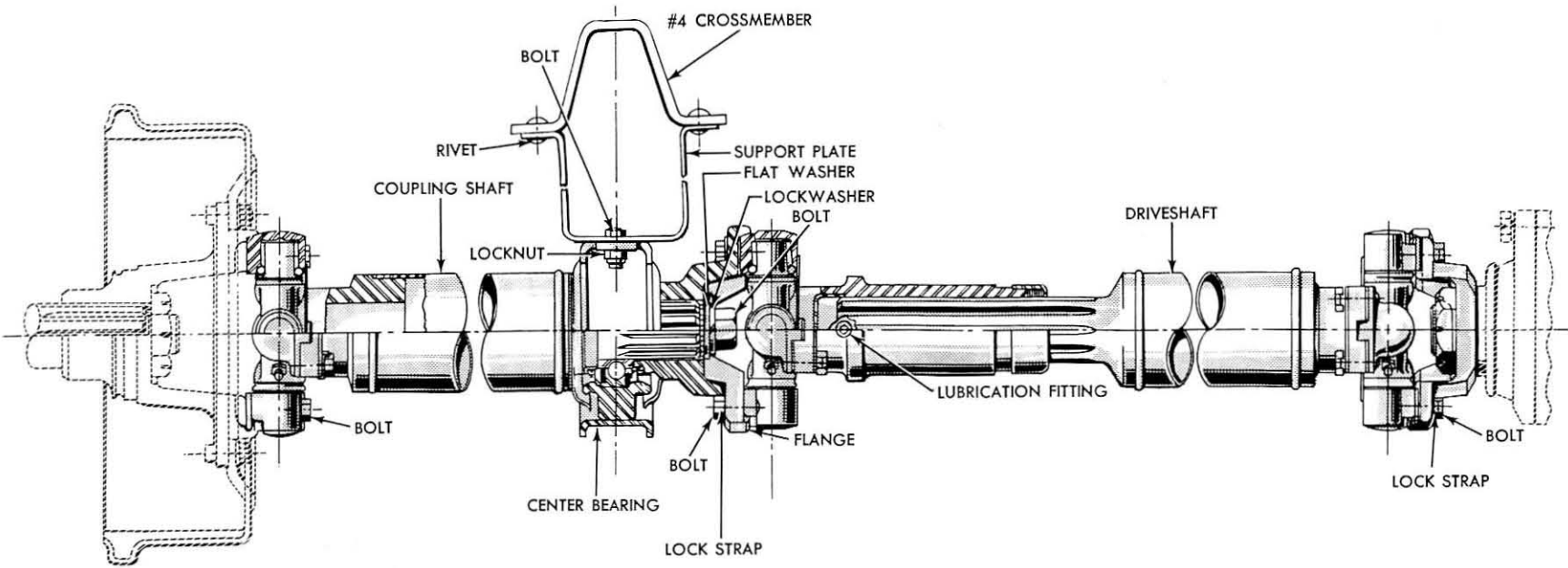

4 AXIS C-C
OF YOK ON
194", 212"

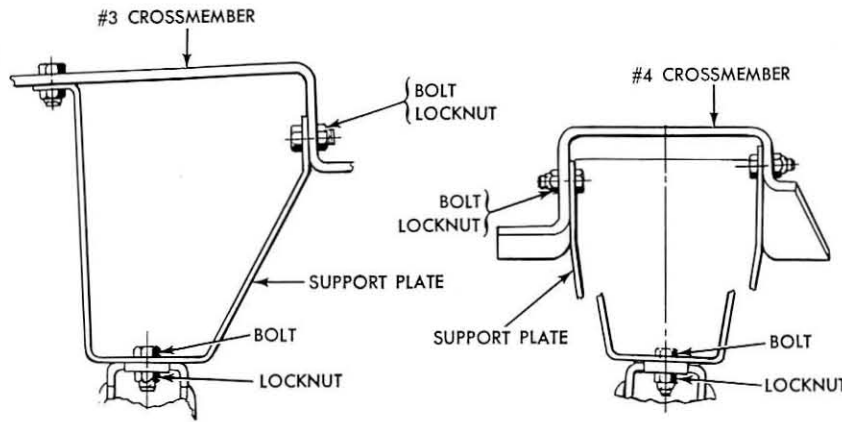

T-850-950 176" W.B.

HDT-850-950 246" W.B.

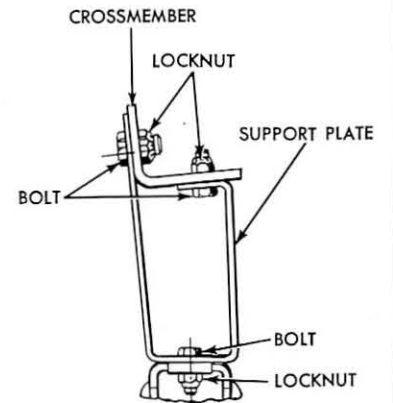

**HDT-850-950 AND 158"
W.B. HDT-850-950**



BUY IT NOW!

Click Here To Order



1962-63
FORD

TRUCK

100-800 SERIES

SHOP MANUAL
SUPPLEMENT



BUY IT NOW!

Click Here To Order

PayPal

AMERICAN EXPRESS
Cards

DISCOVER
NOWUS

MasterCard

VISA

1962-63 FORD TRUCK

100-800 SERIES

SHOP MANUAL SUPPLEMENT

GROUP INDEX

TRUCK IDENTIFICATION	
ENGINES AND EXHAUST SYSTEMS	1
IGNITION SYSTEM AND GOVERNORS	2
FUEL SYSTEM	3
COOLING SYSTEM	4
CLUTCHES AND MANUAL-SHIFT TRANSMISSIONS	5
FORDOMATIC AND HEAVY-DUTY CRUISE-O-MATIC TRANSMISSIONS	6
TRANSMATIC DRIVE TRANSMISSION	7
REAR AXLES, 4-WHEEL DRIVE FRONT AXLE AND DRIVE LINES	8
WHEELS, TIRES, CHASSIS SUSPENSION AND FRAMES	9
STEERING	10
BRAKES	11
GENERATING AND STARTING SYSTEMS	12
LIGHTS, INSTRUMENTS AND ACCESSORIES	13
BODY CONSTRUCTION	14
DOORS, WINDOWS, INTERIOR TRIM AND SEATS	15
MAINTENANCE AND LUBRICATION	16
SPECIFICATIONS AND SPECIAL TOOLS	17



BUY IT NOW!

Click Here To Order



MICHIGAN

FOREWORD

The information in this supplement, when used with the 1961 100-800 Series Ford Truck Shop Manual, provides the necessary information for servicing the 1962 and 1963 100-800 Series Ford Trucks except the Diesel models. Complete 1962 and 1963 maintenance information and specifications are included.

The descriptions and specifications contained in this supplement were in effect at the time the manual was approved for printing. The Ford Division of Ford Motor Company reserves the right to discontinue models at any time, or change specifications or design, without notice and without incurring obligation.

SERVICE DEPARTMENT
FORD DIVISION
FORD MOTOR COMPANY



**SATISFACTION
100%
GUARANTEED**

BUY IT NOW!
Click Here To Order

PayPal American Express Discover MasterCard VISA

1962 FORD TRUCK IDENTIFICATION

MODEL DESIGNATIONS

Ford truck designations consist of two elements, a letter and a three or four digit number. The letter determines the type of truck and the number indicates the size, as follows:

- F..... Conventional Series
- C..... Tilt Cab Series
- T..... Tandem Axle Series
- B..... School Bus Series

- P..... Parcel Delivery Series
- 100, 250, 350, 400..... Light Duty Models
- 500, 550, 600..... Medium Duty Models
- 700, 750, 800..... Heavy Duty Models

For example: the F-350 is a Light Duty conventional model. The C-600 is a Medium Duty Tilt Cab model.

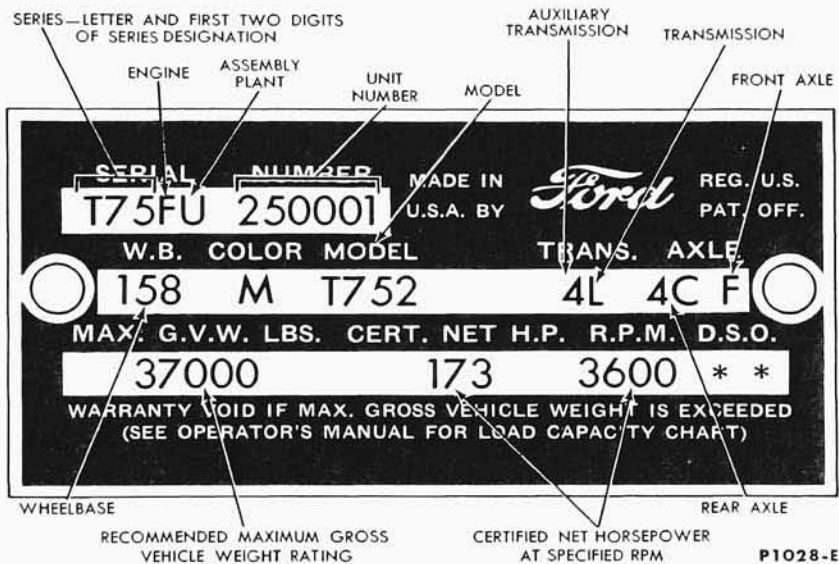

FIG. 1—Typical Truck Rating Plate—1962

TRUCK REGISTRATION RATINGS

Series	Model	RATING		Series	Model	RATING		Series	Model	RATING		
		G.V.W. (lb)	Nominal (ton)			G.V.W. (lb)	Nominal (ton)			G.V.W. (lb)	Nominal (ton)	
F-100	F-100	5,000	½	F-350	F-350	9,800	1	F-700	F-700	21,000	2½	
	F-101	4,000	½		F-351	F-351	7,600		¾	F-701	17,000	2
	F-102	5,000	½	F-500		F-500	15,000		1½	F-702	22,000	2½
	F-113	5,600	½		F-501	F-501	10,000		1	F-703	25,000	3
	F-114	4,000	½			F-600	F-600		17,000	2	F-704	25,000
	F-115	5,600	½	F-601	15,000		1½	F-705	25,000	2½		
			F-602	19,500	2		F-750	F-754	22,000	2½		
			F-613	21,000	2½			F-755	17,000	2		
			F-614	21,000	2½			F-756	22,000	2½		
								F-757	25,000	3		
						F-758	25,000	3				

100% SATISFACTION GUARANTEED

BUY IT NOW!

Click Here To Order

TRUCK REGISTRATION RATINGS (Continued)

Series	Model	RATING		Series	Model	RATING		Series	Model	RATING				
		GVW (lb)	Nominal (ton)			GVW (lb)	Nominal (ton)			GVW (lb)	Nominal (ton)			
F-800	F-800	24,000	2½	C-550	C-550	18,000	1½	P-350	P-350	8,000	¾			
	F-801	17,000	2		C-551	10,000	1		P-351	5,900	½			
	F-802	22,000	2½	C-600	C-600	19,500	2	P-400	P-400	10,000	1			
	F-803	25,000	3		C-601	15,000	1½		P-401	7,700	¾			
	F-804	25,000	3		C-612	21,000	2½	P-500	P-500	15,000	1½			
	F-805	25,000	3		C-613	21,000	2½							
	F-806	22,000	2½		C-700	C-700	22,000					2½	T-700	T-700
	F-814	27,000	3½	C-701		17,000	2	T-701	22,000	2				
	F-815	27,000	3½	C-702		23,000	2½	T-702	29,000	3				
	F-816	27,000	3½	C-703		25,000	3	T-703	32,000	3				
				C-704	25,000	3	T-704	33,000	3					
B-500	B-500	15,000	1½	C-750	C-750	23,000	2½	T-750	T-750	35,000	3½			
	B-501	10,000	1		C-751	17,000	2					T-751	27,000	3½
B-600	B-600	17,000	2		C-752	25,000	3					T-752	37,000	3½
	B-601	15,000	1½		C-753	25,000	3	T-800	T-800	39,000	3½			
	B-602	19,500	2		C-800	C-800	27,000					3½	T-801	30,000
B-700	B-700	21,000	2½	C-801		20,000	2					T-802	41,000	3½
	B-701	17,000	1¾	C-802		27,000	3½					T-803	43,000	4
	B-702	22,000	2½	C-803		27,000	3½					T-804	43,000	4
	B-703	22,000	2½				T-805	45,000	4					
B-704	22,000	2½												
B-750	B-750	22,000	2½											
	B-751	17,000	1¾											
	B-752	22,000	2½											
	B-753	22,000	2½											

ENGINE CODE

Code	Sales Designation	Service and Engineering Designation
A*	223 Six	
B	262 Six	
C	292 MD V-8	EEH, EEJ**—Dual
D	292 HD V-8	EEL—4-Barrel
F	332 HD V-8	ECT—2-Barrel
J	223 Six	EBR, EBS, EBT
N	302 HD V-8	ECS—2-Barrel

*Export only
**P-Series only

CONSECUTIVE UNIT NUMBER

A uniform serial number has been developed to provide a means of identifying annual model year programs and extended production cycles of five or more years without the use of the current model year designation. Basically the system requires the monthly assignment of serial numbers into blocks.

TRANSMISSION CODE

Code	Type
A	3-Speed Standard
B	3-Speed Overdrive
	Fordomatic
	3-Speed M/D Warner T-89C
	3-Speed M/D Warner T-89E

COLOR CODE

Code	Color Name	Paint Spec. Number
A	Raven Black	M30J-1724
C	White	M30J-1525
M	Corinthian White	M30J-1238
F	Baffin Blue	M30J-1449
V	Academy Blue	M30J-1024
L	Dark Green	M30J-1237
J	Rangoon Red	M30J-1515
G	Chrome Yellow	M30J-1526
X	Goldenrod Yellow	M30J-358
B	Caribbean Turquoise	M30J-556
T	Sandshell Beige	M30J-1543

ASSEMBLY PLANT CODE

Code	Plant Location
D	Dallas
E	Mahwah
G	Chicago
H	Lorain (Ohio)
K	Kansas City
N	Norfolk
P	Twin City (St. Paul)
R	San Jose
S	Pilot Plant
U	Louisville

1962 MODEL YEAR

August	205,000 thru 209,999
September	210,000 thru 219,999
October	220,000 thru 229,999
November	230,000 thru 239,999
December	240,000 thru 249,999
January	250,000 thru 259,999
February	260,000 thru 269,999
March	270,000 thru 279,999
April	280,000 thru 289,999
May	290,000 thru 299,999
June	300,000 thru 309,999
July	310,000 thru 319,999
August	320,000 thru 329,999
September	330,000 thru 339,999

AUXILIARY TRANSMISSION CODE

Code	Type
1	Spicer 5831C
2	Spicer 5831D
3	Spicer 7231B
4	Spicer 7231D
5	Spicer 8341A

FRONT AXLE CODE

Code	Type
A	3.92 Ratio (4-Wheel Drive)
B	4.55 Ratio (4-Wheel Drive)
C	6,000 lb.
D	4.55 Ratio (4-Wheel Drive)
E	7,000 lb.
F	9,000 lb.
G	11,000 lb.

100% GUARANTEED

BUY IT NOW!

Click Here To Order

PayPal American Express Discover MasterCard VISA

REAR AXLE CODE

Code	Ratio and Rating
100, 250, 350, 400 Models	
A1	3.73-3.3M
A2	3.92-3.3M
B4	4.56-5M
B6	4.88-5M
01	3.50-2.3M
02	4.00-2.3M
10	3.22-3.3M
11	3.70-3.3M
12	3.89-3.3M
13	4.11-3.3M
22	4.88-7.2M
23	5.13-7.2M
24	4.56-5M
26	4.88-5M
29	5.87-7.2M
32	6.20-11M
34	6.80-11M
41	5.83-13M
42	6.20-13M
44	6.80-13M
52	6.20-14M
54	6.80-14M
62	6.20-15M
64	6.80-15M
66	7.20-15M
73	6.50-16M
75	7.17-16M
82	5.57-18M
83	6.50-18M
85	7.17-18M
87	7.67-18M

Code	Ratio and Rating
100, 250, 350, 400 Models (Continued)	
D1	5.83/8.11-13M
E1	5.83/8.11-14M
E2	6.33/8.81-14M
F1	5.83/8.11-15M
F2	6.33/8.81-15M
G3	6.50/9.04-16M
H2	5.57/7.60-18M
H3	6.50/8.87-18M
H5	7.17/9.77-18M
FCB 700-800	
J1	5.91-21M
J2	6.65-21M
K1	4.88-21M
K2	5.57-21M
K3	6.50-21M
K4	7.17-21M
L1	4.92-21M
L2	5.63-21M
L3	6.39-21M
L4	7.27-21M
S1	4.88/6.65-21M
S2	5.57/7.60-21M
S3	6.50/8.87-21M
S4	7.17/9.77-21M
T1	4.92/6.76-21M
T2	5.63/7.73-21M
T3	6.39/8.78-21M
T4	7.33/10.07-21M

Code	Ratio and Rating
T-700-800	
1A	6.70-22M
1B	7.07-28M
2A	7.79-22M
2B	7.79-28M
T-800	
1C	4.63-30M
2C	4.88-30M
3C	5.57-30M
4C	6.50-30M
5C	7.17-30M
1D	7.75-30M
2D	8.55-30M
1E	4.56-34M
2E	5.85-34M
3E	6.69-34M
4E	7.80-34M
6E	8.60-34M
1F	4.56-34M
2F	4.88-34M
3F	5.57-34M
4F	6.50-34M
5F	7.17-34M
1H	4.63-34M
2H	5.29-34M
3H	5.83-34M
4H	6.83-34M
5H	7.80-34M
6H	8.60-34M
1N	7.60-34M
3N	8.38-34M

**SATISFACTION
100%
GUARANTEED**

BUY IT NOW!

Click Here To Order









1963 FORD TRUCK IDENTIFICATION

Two changes have been made on the 1963 "Rating Plate" (Fig. 2). A WARRANTY NUMBER block replaces the SERIAL NUMBER block, and a BODY block, designating the cab or body type installed on the vehicle, has also been added.

The complete official Serial Number is stamped on various frame and body locations. This number is the same as the Warranty Number but is preceded and followed by asterisks.

WARRANTY NUMBER

The Warranty Number identifies the vehicle series, engine type, assembly plant, and consecutive unit number.

MODEL DESIGNATIONS

Ford truck model designations consist of two elements, a letter and a three

or four-digit number. The letter determines the type of truck and the number indicates the size, as follows:

F	Conventional Series
C	Tilt Cab Series
T	Tandem Axle Series
B	School Bus Series
N	Cab Over Engine
P	Parcel Delivery Series
100, 250, 350, 400	Light Duty Models
500, 550, 600	Medium Duty Models
700, 750, 800	Heavy Duty Models
3500, 4000, 5000, 6000, 7000	Dagenham Diesel

For example: the F-350 is a light-duty conventional model. The C-600 is a medium-duty tilt cab model.

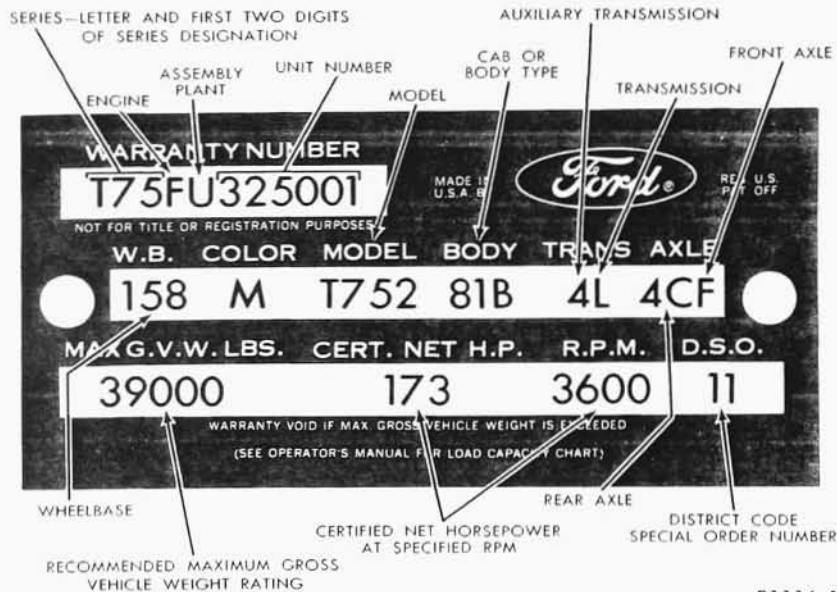

P1116-A

FIG. 2—Typical Truck Rating Plate—1963

TRUCK REGISTRATION RATINGS

Series	Model Code	RATING		Series	Model Code	RATING		Series	Model Code	RATING	
		GVW (lb)	Nominal (ton)			GVW (lb)	Nominal (ton)			GVW (lb)	Nominal (ton)
B-500	B-500	15,000	1½	B-750	B-750	22,000	2½	C-700	C-700	22,000	2½
	B-501	10,000	1		B-751	17,000	2		C-701	17,000	2
B-600	B-600	17,000	2		B-752	22,000	2½		C-702	24,000	2½
	B-601	15,000	1½		B-753	22,000	2½		C-703	25,000	3
	B-602	19,500	2	C-550	C-550	18,000	1½		C-704	25,000	3
C-600	C-600	19,500	2		C-551	10,000	1	C-750	C-750	24,000	2½
	C-601	15,000	1½	C-800	C-800	27,000	3½		C-751	17,000	2
	C-610	21,000	2½		C-801	20,000	2		C-752	25,000	3
	C-611	22,000	2½		C-802	27,000	3½		C-753	25,000	3
	C-612	23,000	2½		C-803	27,000	3½	C-804	C-804	27,000	3½
	C-613	23,000	2½								
	C-614	23,000	2½								



BUY IT NOW!

Click Here To Order



TRUCK REGISTRATION RATINGS (Continued)

Series	Model Code	RATING		Series	Model Code	RATING		Series	Model Code	RATING	
		GVW (lb)	Nominal (ton)			GVW (lb)	Nominal (ton)			GVW (lb)	Nominal (ton)
CT-750	L-750	39,000	3½	F-705	F-705	23,000	2½	N-706	N-706	23,000	2½
	L-751	27,000	2½		F-706	23,000	2½		N-707	24,000	2½
	L-752	41,000	4		F-707	24,000	2½		N-708	25,000	3
CT-800	L-800	43,000	4		F-708	25,000	3		N-709	25,000	3
	L-801	27,000	2½		F-709	25,000	3		N-750	N-750	22,000
	L-802	45,000	4	F-750	F-750	22,000	2½	N-751		17,000	2
	L-803	49,000	5		F-751	17,000	2	N-752		23,000	2½
F-100	F-100	5,000	½		F-752	23,000	2½	N-753		23,000	2½
	F-101	4,000	½		F-753	23,000	2½	N-754		24,000	2½
	F-102	5,000	½		F-754	24,000	2½	N-755	25,000	3	
F-100 (4 x 4)	F-110	5,600	½	F-755	25,000	3	N-756	25,000	3		
	F-111	4,000	½	F-756	25,000	3	P-100	P-100	4,300	½	
	F-112	5,600	½	F-800	F-800	23,000		2½	P-101	5,000	½
F-250	F-250	7,400	¾		F-801	17,000		2	P-350	P-350	8,000
	F-251	4,900	½		F-802	23,000	2½	P-351		5,900	½
F-250 (4 x 4)	F-260	6,600	¾		F-803	24,000	2½	P-400	P-400	10,000	1
	F-261	4,900	½		F-804	24,000	2½		P-401	7,700	¾
	F-262	7,400	¾	F-805	25,000	3	P-500	P-500	15,000	1½	
F-350	F-350	9,800	1	F-806	25,000	3		P-501	10,000	1	
	F-351	7,800	¾	F-807	27,000	3½		P-600	P-600	17,000	2
F-500	F-500	15,000	1½	F-808	27,000	3½	P-601		15,000	1½	
	F-501	10,000	1	F-809	27,000	3½	P-602		18,500	2	
	F-502	16,000	1½	N-500	N-500	15,000	1½	T-700	T-700	28,000	3
	F-503	18,000	2		N-501	10,000	1		T-701	22,000	2
F-600	F-600	17,000	2		N-502	16,000	1½		T-702	29,000	3
	F-601	15,000	1½	N-503	18,000	2	T-703		36,000	3½	
	F-602	19,500	2	N-600	N-600	17,000	2	T-704	37,000	3½	
	F-610	21,000	2½		N-601	15,000	1½	T-750	T-750	37,000	3½
	F-611	22,000	2½		N-602	19,500	2		T-751	27,000	2½
F-612	23,000	2½	N-610	21,000	2½	T-752	39,000		3½		
F-613	23,000	2½	N-611	22,000	2½	T-753	41,000		4		
F-700	F-700	20,000	2½	N-612	23,000	2½	T-800		T-800	43,000	4
	F-701	17,000	2	N-613	23,000	2½		T-801	27,000	2½	
	F-702	21,000	2½	N-700	N-700	20,000		2½	T-802	43,000	4
	F-703	22,000	2½		N-701	17,000		2	T-803	45,000	4
	F-704	23,000	2½		N-702	21,000	2½	T-804	49,000	5	
					N-703	22,000	2½				
					N-704	23,000	2½				
			N-705	23,000	2½						

ENGINE CODE

Code	Cubic Inch Displacement
S*	144-IV
J	223-IV
B	262-IV
C	292-2V
D	292-4V
N	302-2V
I	302-4V
F	332-2V
W	332-4V
4	220 Diesel Ford (DGHM)
E	330 Diesel Ford (DGHM)

AUXILIARY TRANSMISSION CODES*

Code	Type	Ratio
1	3 Speed Spicer 5831-C	1.27 / .85
2	3 Speed Spicer 5831-D	2.0 / .85
3	3 Speed H.D. Spicer 7231-B	1.24 / .86
4	3 Speed H.D. Spicer 7231-D	2.14 / .86
5	4 Speed Spicer 8341-A	2.40 / 1.29 / .84
6	3 Speed Spicer 8031-C	2.59 / .79
7	3 Speed Spicer 8031-G	1.29 / .84
8	4 Speed Spicer 7041	2.31 / 1.21 / .83

NOTE: When required, the auxiliary transmission code will be stamped directly in front of the transmission code.

*If the "New Process" transmission is installed, the auxiliary transmission code will bear the suffix "N".

CONSECUTIVE UNIT NUMBER

A uniform serial number has been developed to provide a means of identifying annual model year programs and extended production cycles of five or more years without the use of the current model year designation. Basically the system requires the monthly assignment of serial numbers into blocks.

1963 MODEL YEAR

August	325,000 thru 329,999
September	330,000 thru 339,999

October	340,000 thru 349,999
November	350,000 thru 359,999
December	360,000 thru 369,999
January	370,000 thru 379,999
February	380,000 thru 389,999
March	390,000 thru 399,999
April	400,000 thru 409,999
May	410,000 thru 419,999
June	420,000 thru 429,999
July	430,000 thru 439,999
August	440,000 thru 449,999
September	450,000 thru 459,999

IMPRESSION

BUY IT NOW!

Click Here To Order

ASSEMBLY PLANT CODES

Code	Plant Location
D	Dallas
E	Mahwah
G	Chicago
H	Lorain (Ohio)
K	Kansas City
N	Norfolk
P	Twin City (St. Paul)
R	San Jose
S	Pilot Plant

COLOR CODE

Code	Sales Name	*Paint Spec. Number
A	Raven Black	M30J-1724
B	Caribbean Turquoise	M30J-556
C	Chrome Yellow	M30J-1525
Y	Glacier Blue	M30J-1553
G	White	M30J-1526
J	Rangoon Red	M30J-1515
L	Holly Green	M30J-1237
M	Corinthian White	M30J-1238
T	Sandshell Beige	M30J-1543
V	Academy Blue	M30J-1024
K	Driftwood	M30J-1618

*"M32J" alternate with "M30J"

DSO

Trucks built to Domestic Special Order have the order number and the District Code number of the district which ordered the unit stamped in this space. If the truck is a regular production unit, only the District Code will appear.

DISTRICT CODE

Code	District
11	Boston
12	Buffalo
13	New York
14	Pittsburgh
15	Newark
21	Atlanta
22	Charlotte
23	Philadelphia
24	Jacksonville
25	Richmond
26	Washington
31	Buffalo
32	Cleveland
33	Detroit
34	Indianapolis
35	Lansing
36	Louisville
41	Chicago
42	Fargo
43	Rockford
44	Twin Cities
45	Davenport
51	Denver
52	Des Moines
53	Kansas City
54	Omaha
55	St. Louis
61	Dallas
62	Houston
63	Memphis
64	New Orleans
65	Oklahoma City
71	Los Angeles
72	San Jose
73	Salt Lake City
74	Seattle
81	Ford of Canada
83	Government
84	Home Office Reserve
85	American Red Cross
86	Diplomatic Service Comm.
89	Transportation Service
90-99	Export

TRANSMISSION CODE

Code	Description
A	*3-Speed Ford Standard Duty
B	*3-Speed Ford w/Warner T86 Overdrive
D	*3-Speed Warner T89-C(MD)
E	*3-Speed Warner T87-E(HD)
G	*3-Speed HD Cruise-O-Matic
F	4-Speed Warner T98-A
J	5-Speed Clark 250-V Direct
K	5-Speed Clark 251-VO Overdrive
L	5-Speed Clark 2651-VI Direct
M	5-Speed Clark 264-VO Overdrive
W	5-Speed Clark 2621-VI Direct
N	5-Speed Spicer 5652 Direct
P	5-Speed Spicer 5756-B Direct
Q	5-Speed Spicer 6352 Direct (Iron)
4	5-Speed Spicer 6354 Direct (Alum.)
U	5-Speed Spicer 6352-B Direct (Iron)
8	5-Speed Spicer 6354-B Direct (Alum.)
V	5-Speed Spicer 6452-A Direct (Iron)
7	5-Speed Spicer 6454-A Direct (Alum.)
S	5-Speed Spicer 6453-A Overdrive (Iron)
5	5-Speed Spicer 6455-A Overdr. (Alum.)
R	5-Speed Spicer 6852-G Direct (Iron)
6	5-Speed Spicer 6854-G Direct (Alum.)
A	5-Speed Fuller 5-W-74 Direct
B	5-Speed Spicer 8051-A Overdrive (Iron)
Y	5-Speed Spicer 8055-A Overdr. (Alum.)
C	5-Speed Spicer 8052 Direct (Iron)
Z	5-Speed Spicer 8054 Direct (Alum.)
H	6-Speed Transmatic MT-30
E	6-Speed Transmatic MT-40
G	6-Speed Transmatic MT-42
T	8-Speed Fuller R-46 Direct
D	10-Speed Fuller R-96 Direct (Iron)
E	10-Speed Fuller RA-96 Direct (Alum.)
I	10-Speed Fuller R-960 Overdr. (Iron)
G	10-Speed Fuller RA-960 Overdr. (Alum.)
O	12-Speed Spicer 8125 Overdr. (Alum.)

*Transmissions not used at Louisville Assembly Plant

TRUCK REGISTRATION RATINGS—
DAGENHAM DIESEL POWERED UNITS

Series	Model Code	S—Special R—Regular L—Light H—Heavy	RATING	
			GVW (lbs)	Nominal (ton)
C-6000	D-600	R	19,500	2
	D-601	L	15,000	1½
	D-610	H	21,000	2½
	D-611	H	22,000	2½
	D-612	H	23,000	2½
	D-613	S	23,000	2½
	D-614	S	23,000	2½
C-7000	D-700	R	22,000	2½
	D-701	L	17,000	2
	D-702	H	24,000	2½
	D-703	H	25,000	3
	D-704	S	25,000	3

Series	Model Code	S—Special R—Regular L—Light H—Heavy	RATING	
			GVW (lbs)	Nominal (ton)
N-7000	R-700	R	20,000	2½
	R-701	L	17,000	2
	R-702	H	21,000	2½
	R-703	H	22,000	2½
	R-704	H	23,000	2½
	R-705	S	23,000	2½
	R-706	S	23,000	2½
	R-707	H	24,000	2½
	R-708	H	25,000	3
P-3500	G-350	R	8,000	¾
	G-351	L	5,900	½
P-4000	G-400	R	10,000	1
	G-401	L	7,700	¾
P-5000	G-500	R	15,000	1½
	G-501	L	10,000	1



BUY IT NOW!

Click Here To Order



REAR AXLE CODE

Code	Ratio and Rating
1	3.50—2.3M
2	4.00—2.3M
3	3.80—2.3M
4	4.50—2.3M
5	4.10—2.3M
11	3.70—3.3M
12	3.89—3.3M
13	4.11—3.3M
21	5.83—7.2M
22	4.88—7.2M
23	5.13—7.2M
24	4.56—5 M
26	4.88—5 M
29	5.87—7.2M
30	5.29—11 M
32	6.20—11 M
34	6.80—11 M
41	5.83—13 M
42	6.20—13 M
44	6.80—13 M
52	6.20—14 M
54	6.80—14 M
62	6.20—15 M
64	6.80—15 M
66	7.20—15 M
73	6.50—17 M
75	7.17—17 M
84	5.57—18.5M
86	6.14—18.5M
87	6.50—18.5M
88	7.17—18.5M
89	7.67—18.5M
1A	6.70—21 M
2A	7.79—21 M
1C	4.63—32 M
2C	4.88—32 M
3C	5.57—32 M
4C	6.50—32 M
5C	7.17—32 M
6C	7.60—32 M

Code	Ratio and Rating
1D	7.75—32 M
2D	8.55—32 M
1E	4.56—34 M
2E	5.85—34 M
3E	6.69—34 M
4E	7.80—34 M
6E	8.60—34 M
1F	4.56—34 M
2F	4.88—34 M
3F	5.57—34 M
4F	6.50—34 M
5F	7.17—34 M
6F	7.60—34 M
1G	5.09—34 M
2G	5.90—34 M
3G	6.70—34 M
4G	7.67—34 M
5G	8.43—34 M
1H	4.63—34 M
2H	5.29—34 M
3H	5.83—34 M
4H	6.83—34 M
5H	7.80—34 M
6H	8.60—34 M
1N	7.60—34 M
3N	8.38—34 M
A1	3.73—3.3M
A2	3.92—3.3M
A5	4.10
B4	4.56—5 M
B6	4.88—5 M
D1	5.83/8.11—13 M
F1	5.83/8.11—15 M
F2	6.33/8.81—15 M
G3	6.50/9.04—17 M

Code	Ratio and Rating
H4	5.57/7.60—18.5M
H6	6.14/8.38—18.5M
H7	6.50/8.87—18.5M
H8	7.17/9.77—18.5M
K1	4.88—21 M
K2	5.57—21 M
K3	6.50—21 M
K4	7.17—21 M
K5	6.14—21 M
S1	4.88/6.65—21 M
S2	5.57/7.60—21 M
S3	6.50/8.87—21 M
S4	7.17/9.77—21 M
S5	4.33/5.91—21 M
S6	4.56/6.21—21 M
S7	6.14/8.38—21 M
A	4.11—34 M
B	4.33—34 M
C	4.63—34 M
D	5.29—34 M
E	5.57—34 M
F	6.14—34 M
G	6.83—34 M
QA	4.41—34 M
AH	4.63—34 M
BH	5.29—34 M
CH	5.83—34 M
DH	6.83—34 M
EH	7.80—34 M
FH	8.60—34 M
AQ	4.63—34 M
BQ	5.29—34 M
CQ	5.83—34 M
DQ	6.83—34 M
EQ	7.80—34 M
FQ	8.60—34 M



BUY IT NOW!

Click Here To Order

PayPal

Discover
Cards

DISCOVER
NOWUS

MasterCard

VISA