

1964 FORD

Thunderbird



SHOP MANUAL



BUY IT NOW!

Click Here To Order



PayPal

AMERICAN EXPRESS
Cards

DISCOVER
NOWUS

MasterCard

VISA

Copyright © 2009, Forel Publishing Company, LLC, Woodbridge, Virginia

All Rights Reserved. No part of this book may be used or reproduced in any manner whatsoever without written permission of Forel Publishing Company, LLC. For information write to Forel Publishing Company, LLC, 3999 Peregrine Ridge Ct., Woodbridge, VA 22192

1964 Ford Thunderbird Shop Manual

EAN: 978-1-60371-014-5

ISBN: 1-60371-014-0

Forel Publishing Company, LLC

3999 Peregrine Ridge Ct.

Woodbridge, VA 22192

Email address: webmaster@ForelPublishing.com

Website: <http://www.ForelPublishing.com>



This publication contains material that is reproduced and distributed under a license from Ford Motor Company. No further reproduction or distribution of the Ford Motor Company material is allowed without the express written permission of Ford Motor Company.

Note from the Editor

This product was created from the original Ford Motor Company's publication. Every effort has been made to use the original scanned images, however, due to the condition of the material; some pages have been modified to remove imperfections.

Disclaimer

Although every effort was made to ensure the accuracy of this book, no representations or warranties of any kind are made concerning the accuracy, completeness or suitability of the information, either expressed or implied. As a result, the information contained within this book should be used as general information only. The author and Forel Publishing Company, LLC shall have neither liability nor responsibility to any person or entity with respect to any loss or damage caused, or alleged to be caused, directly or indirectly by the information contained in this book. Further, the publisher and author are not engaged in rendering legal or other professional services. If legal, mechanical, electrical, or other expert assistance is required, the professional should be sought.



1964

THUNDERBIRD

SHOP MANUAL

GROUP INDEX

IDENTIFICATION	1
BRAKES	2
SUSPENSION—STEERING—WHEELS & TIRES	3
REAR AXLE	4
CLUTCH—DRIVELINE	5
MANUAL TRANSMISSION (Not Applicable)	6
AUTOMATIC TRANSMISSION	7
ENGINE	8
IGNITION SYSTEM	9
FUEL SYSTEM	10
COOLING SYSTEM	11
EXHAUST SYSTEM	12
CHARGING SYSTEM	13
STARTING SYSTEM	14
LIGHTS, WIRING, ETC.	15
VENTILATING—HEATING—AIR/COND.—RADIO	16
BODY—FITS, SEATS, ETC.	17
SOFT TRIM—CONVERTIBLE TOP	18
MAINTENANCE SCHEDULE	19
MAINTENANCE OPERATIONS	20
LUBRICATION CHARTS	21
SPECIAL SERVICE TOOLS	22
INDEX	23



BUY IT NOW!

Click Here To Order

ENT
ON
ANY

PayPal

Discover
Cards

DISCOVER
NOWUS

MasterCard

VISA

ENT ON ANY
MICHIGAN

FOREWORD

This shop manual provides the Service Technician with complete information for the proper servicing of the 1964 Thunderbird.

The information is grouped according to the type of work being performed, such as diagnosis and testing, frequently performed adjustments and repairs, in-vehicle adjustments, overhaul, etc. Specifications and recommended special tools are included.

Refer to the opposite page for important vehicle identification data.

The descriptions and specifications in this manual were in effect at the time this manual was approved for printing. The Ford Motor Company reserves the right to discontinue models at any time, or change specifications or design, without notice and without incurring obligation.

SERVICE DEPARTMENT

FORD MOTOR COMPANY



THUNDERBIRD IDENTIFICATION

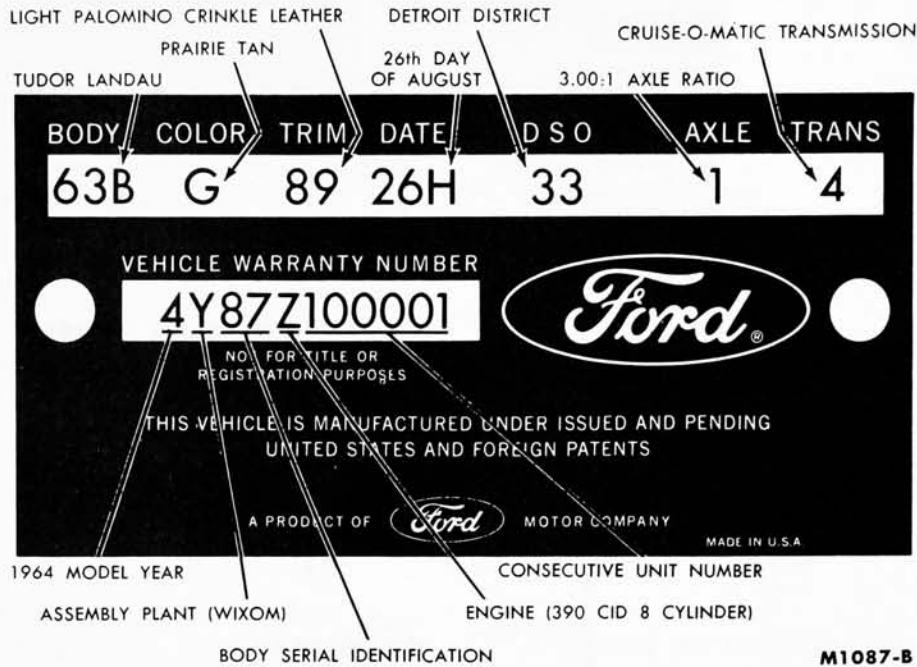

FIG. 1—Thunderbird Warranty Plate

Figure 1 illustrates a Thunderbird Warranty plate and its elements. The Warranty plate is attached to the left door front pillar. The official Vehicle Identification number for title and registration purposes is stamped on the hood support top surface to the right of the hood lock plate (Fig. 2). Do not use the Vehicle Warranty number which appears on the Warranty plate for title or registration purposes.

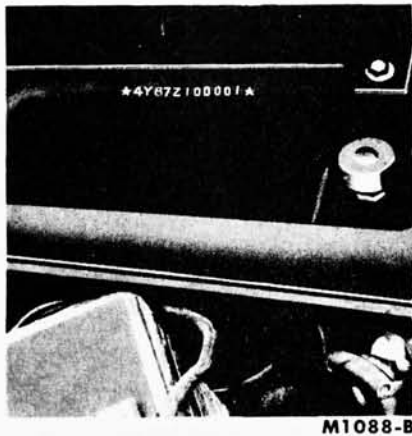

FIG. 2—Vehicle Identification Number Location

VEHICLE DATA

Example (Fig. 1):

63B	G	89	26H	33	1	4	
63B	Tudor Landau	Prairie Tan	Light Palomino Crinkle Leather	26th Day of August	Detroit	3.00:1 Axle Ratio	Cruise-O-Matic



BUY IT NOW!

Click Here To Order



BODY

63A	Tudor Hardtop
63B	Tudor Landau
76A	Tudor Convertible

COLOR

If a special paint is used, the paint color space will not be stamped.

Code	M-32-J Number	Color	Sales Name
A	1724	Black	Raven Black
B	1638	Peacock	Pagoda Green
E	1446	Light Gray Metallic	Silver Mink
F	1226	Light Blue	Arcadian Blue
G	1636	Buff	Prairie Tan
H	1544	Dark Blue Metallic	Caspian Blue
I	1635	Aztec Gold	Florentine Green
J	1515	Red	Rangoon Red
L	1637	Bittersweet	Amoan Coral
M	1619	White	Wimbledon White
N	921	Platinum	Dimond Blue
Q	1624	Medium Blue Metallic	Brittany Blue
R	1633	Yellow	Phoenician Yellow
S	1453	Dark Green Metallic	Cascade Green
T	1631	Light Beige	Navaho Beige
U	1070	Medium Turquoise Metallic	Patrician Green
W	1555	Pink Metallic	Rose Beige
X	1632	Maroon Metallic	Vintage Burgundy
Z	1630	Medium Beige Metallic	Chantilly Beige

TRIM

Deviation trim sets will use existing trim codes plus a suffix. A trim code with a numerical suffix is not serviced, while a trim code with an alphabetical suffix is serviced.

Code	Crinkle Vinyl
50	Light Rose Beige D/L
51	Light Silver Blue Metallic
52	Light Blue D/L
54	Pearl Beige

TRIM (Continued)

Code		Crinkle Vinyl
55	Red
56	Black
57	Light Turquoise D/L
58	Light Aztec Gold
59	Light Palomino
		Pompeii Cloth and Crinkle Vinyl
71	Silver Blue.....	Light Silver Blue Metallic
72	Blue.....	Light Blue D/L
74	Beige.....	Pearl Beige
76	Black.....	Black
		Crinkle Leather
82	Light Blue D/L
83	White
85	Red
86	Black
89	Light Palomino

DATE

The code letters for the month are preceded by a numeral to show the day of the month when the Thunderbird was completed. The second year code letters are to be used if model production exceeds 12 months.

	First	Second
Month	Model Year	Model Year
January.....	A.....	N.....
February.....	B.....	P.....
March.....	C.....	Q.....
April.....	D.....	R.....
May.....	E.....	S.....
June.....	F.....	T.....
July.....	G.....	U.....
August.....	H.....	V.....
September.....	J.....	W.....
October.....	K.....	X.....
November.....	L.....	Y.....
December.....	M.....	Z.....

DSO

Thunderbirds built to a Domestic Special Order, Foreign Special Order, or Pre-Approved Order have the complete order number recorded in this space. Also appearing in this space is the two digit code number of the District which ordered the unit. If the unit is regular production, only the District code number will appear.

DISTRICT CODE

Code	District	Code	District
11	Boston	45	Davenport
12	Buffalo	51	Denver
13	New York	52	Des Moines
14	Pittsburgh	53	Kansas City
15	Newark	54	Omaha
21	Atlanta	55	St. Louis
22	Charlotte	61	Dallas
23	Philadelphia	62	Houston
24	Jacksonville	63	Memphis
25	Richmond	64	New Orleans
26	Washington	65	Oklahoma City
31	Cincinnati	71	Los Angeles
32	Cleveland	72	San Jose
33	Detroit	73	Salt Lake City
34	Indianapolis	74	Seattle
35	Lansing	81	Ford of Canada
36	Louisville	83	Government
41	Chicago	84	Home Office Reserve
	Fargo	85	American Red Cross
	Rockford	89	Transportation Services

AXLE CODE

Code	Ratio
1.....	3.00:1

TRANSMISSION CODE

Code	Type
4.....	Cruise-O-Matic

VEHICLE WARRANTY NUMBER

Example (Fig. 1): 4Y87Z100001

4.....	1964 Model
Y.....	Wixom Assembly Plant
87.....	Tudor Landau
Z.....	8 Cylinder 390 Cubic Inch
100001.....	First Unit built

MODEL YEAR

The number "4" designates 1964

ASSEMBLY PLANT CODES

Code	Location
Y.....	Wixom Assembly Plant
5.....	Pilot Plant

MODEL CODES

Code	Type
83.....	Tudor Hardtop
85.....	Convertible
87.....	Tudor Landau

ENGINE CODES

Code	Type
Z.....	8 Cylinder 390 Cubic Inch (4 barrel)
9.....	8 Cylinder 390 Cubic Inch (4 barrel Low Compression)

CONSECUTIVE UNIT NUMBER

The assembly plant, with each model year, begins with consecutive unit number 100001 and continues on for each unit built.

100% SATISFACTION GUARANTEED

BUY IT NOW!

Click Here To Order

PayPal, Discover, American Express, MasterCard, VISA

BRAKES

GROUP 2

PART 2-1	PAGE	PART 2-3	PAGE
GENERAL BRAKE SERVICE	2-1	SPECIFICATIONS	2-21
PART 2-2			
BRAKE SYSTEM	2-6		

PART 2-1 GENERAL BRAKE SERVICE

Section	Page	Section	Page
1 Diagnosis and Testing	2-1	3 Cleaning and Inspection	2-5
2 Common Adjustments and Repairs	2-3		

1 DIAGNOSIS AND TESTING

PRELIMINARY TESTING

1. Check the fluid level in the master cylinder, and add FoMoCo heavy-duty brake fluid if required.
2. Push the brake pedal down as far as it will go while the engine is running or vacuum is in system and car is standing still. If the pedal travels more than halfway between the released position and the floor, check the brake adjustment and the automatic adjusters.

To check adjuster operation, check the shoes and the adjuster components for binding or improper installation and follow the procedure described under "Brake Shoe Adjustments" in Part 2-2, Section 2.

Make several reverse brake stops to ensure uniform adjustment at all wheels.

press the pedal and hold it in the applied position. Start the engine. If the vacuum system is operating, the pedal will tend to fall away under foot pressure and less pressure will be required to hold the pedal in the applied position. If no action is felt, the vacuum booster system is not functioning. Follow the procedures in the "Booster Diagnosis Guide."

4. With the engine shut off, exhaust all vacuum in the system. Depress the brake pedal and hold it in the applied position. If the pedal gradually falls away under this pressure, the hydraulic system is leaking. Check all tubing, hoses, wheel cylinders, and connections for leaks.

If the brake pedal movement feels spongy, bleed the hydraulic system to remove air from the lines and cylinder. See "Hydraulic System Bleeding," Section 2. Also, check for leaks or insufficient fluid.

5. Should one of the brakes be locked and the car must be moved, open the brake cylinder bleeder

screw long enough to let out a few drops of brake fluid. **This bleeding operation will release the brakes, but it will not correct the cause of the trouble.**

ROAD TEST

The car should be road tested only if the brakes will safely stop the car. Apply the brakes at a speed of 25-30 mph to check for the existence of the trouble symptoms listed in Table 1, with the exception of brake chatter and those symptoms resolved in the preliminary tests. For each of the symptoms encountered, check and eliminate the causes which are also listed in Table 1. To check for brake chatter or surge, apply the brakes lightly at approximately 50 mph.

For booster removal and installation procedures, refer to Part 2-2, Section 3. For disassembly and assembly procedures, refer to Part 2-2, Section 4. For cleaning and inspection refer to Part 2-1, Section 3.

100% SATISFACTION GUARANTEED

BUY IT NOW!

Click Here To Order

PayPal American Express Discover MasterCard VISA

TABLE 1—Brake Trouble Symptoms and Possible Causes

Possible Causes of Trouble Symptoms	Trouble Symptoms												
	One Brake Drags	All Brakes Drag	Hard Pedal	Spongy Pedal	Car Pulls to One Side	One Wheel Locks	Brakes Chatter	Excessive Pedal Travel	Pedal Gradually Goes to Floor	Brakes Uneven	Shoe Click After Release	Noisy or Grabbing Brakes	Brakes Do Not Apply
Mechanical Resistance at Pedal or Shoes		x	x										
Brake Line Restricted	x	x	x		x								
Leaks or Insufficient Fluid				x				x	x				x
Improper Tire Pressure					x					x			
Improperly Adjusted or Worn Wheel Bearing	x				x								
Distorted or Improperly Adjusted Brake Shoe	x	x	x		x	x		x				x	
Faulty Retracting Spring	x				x								
Drum Out of Round	x				x		x						
Lining Glazed or Worn			x		x	x	x	x				x	x
Oil or Grease on Lining					x	x	x			x		x	x
Loose Carrier Plate	x					x	x						
Loose Lining							x						
Scored Drum										x		x	
Dirt on Drum-Lining Surface												x	
Faulty Brake Cylinder	x				x	x						x	
Dirty Brake Fluid	x	x								x			x
Faulty Master Cylinder		x						x	x				x
Air in Hydraulic System	x			x				x					x
Self Adjusters Not Operating					x			x					
Insufficient Shoe-to-Carrier Plate Lubrication	x										x	x	
Tire Tread Worn						x							
Poor Lining to Drum Contact							x						
Front Suspension							x						
Worn Hubs											x		
								x					

100% SATISFACTION GUARANTEED
BUY IT NOW!
 Click Here To Order

PayPal American Express Discover MasterCard VISA

BRAKE BOOSTER TROUBLE DIAGNOSIS GUIDE

<p>BOOSTER INOPERATIVE— HARD PEDAL</p>	<p>If the preliminary tests show that the booster is inoperative or if a hard pedal condition still exists after eliminating the causes of "Hard Pedal" listed in Table 1, the trouble may be caused by vacuum leakage. Disconnect the vacuum line at the booster, remove the vacuum manifold and check valve assembly, and look for a sticking or faulty check valve. Check all vacuum connections for leakage or obstruction. Check all hoses for a leaking or collapsed</p>	<p>condition. Repair or replace parts as necessary.</p> <p>If the foregoing procedure does not eliminate the trouble, remove the booster from the car. Separate the booster body from the end plate, and check the bellows, booster body, and diaphragm assembly for damage that would cause leaks. When assembling, be sure that the diaphragm assembly is properly positioned. Improper location could cause leakage between the vacuum and atmospheric sides of the diaphragm.</p>
<p>BRAKES DRAG OR GRAB</p>	<p>If the brakes still drag or grab after eliminating the causes listed in Table 1, the condition is probably caused by a sticking or damaged</p>	<p>valve plunger assembly. Remove and disassemble the booster. Clean, inspect, and replace parts as necessary.</p>
<p>SELF APPLICATION OF BRAKES WHEN ENGINE STARTS</p>	<p>Remove and disassemble the booster. Check the diaphragm for being out of locating radii in the housing. Check for a sticking or un-</p>	<p>seated atmospheric valve. Clean, inspect, and replace parts as necessary. Be sure that the diaphragm is properly located when assembling.</p>

2 COMMON ADJUSTMENTS AND REPAIRS

PARKING BRAKE LINKAGE ADJUSTMENT

Check the parking brake cables when the brakes are fully released. If the cables are loose, adjust them as follows:

1. Fully release the parking brake pedal by pushing down the manual release lever.
2. Raise the car.
3. Adjust the equalizer lever against the cable spring on the pedal

cable to the dimension shown in Fig. 1.

4. Loosen the adjusting nut on the equalizer rod, and then turn the lock nut in front of the equalizer several turns forward.

5. Depress the parking brake pedal $1\frac{3}{4}$ inches from its normal released position.

6. While turning the rear wheels in a rearward direction, turn the adjusting nut against the equalizer until a moderate drag is felt (Fig. 1).

7. When the cables are properly adjusted, tighten both nuts against the equalizer.

8. Release the parking brake, and check to make sure that the brake shoes return to the fully released position.

9. Depress the parking brake pedal two inches. Under normal conditions, this will satisfactorily hold the car.

10. Release the parking brake again, and then depress the pedal $\frac{1}{2}$ inch. The brakes should not drag with the pedal depressed $\frac{1}{2}$ inch.

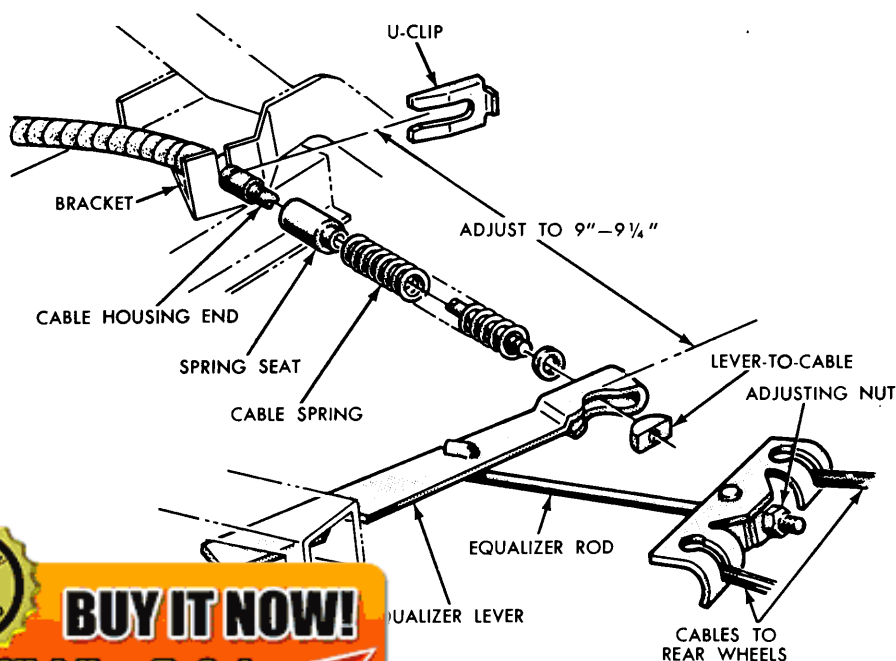

MASTER CYLINDER PUSH ROD ADJUSTMENT

The push rod is provided with an adjustment screw to maintain the



BUY IT NOW!

Click Here To Order



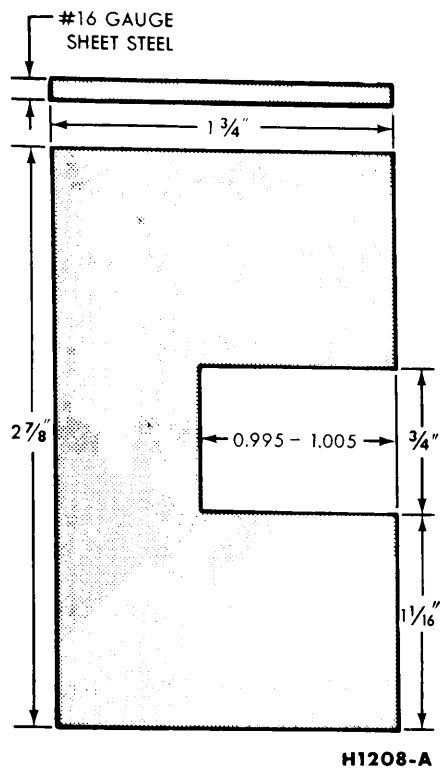

FIG. 2—Push Rod Gauge Dimensions

correct relationship between the booster control valve plunger and the master cylinder piston. Failure to maintain this relationship will prevent the master cylinder piston from completely releasing hydraulic pressure and can cause the brakes to drag.

To check the adjustment of the screw, fabricate a gauge of the dimensions shown in Fig. 2. Then

place the gauge against the master cylinder mounting surface of the booster body as shown in Fig. 3. The push rod screw should be adjusted so that the end of the screw just touches the inner edge of the slot in the gauge.

This is an approximate adjustment only. To verify the adjustment, look through the make-up (rear) port when installing the master cylinder to the booster. The master cylinder piston should not move more than 0.015 inch as it contacts the push rod. No movement (exact contact) is ideal.

HYDRAULIC SYSTEM BLEEDING

When any part of the hydraulic system has been disconnected for repair or replacement, air may get into the lines and cause spongy pedal action. Bleed the hydraulic system after it has been properly connected to be sure that all air is expelled from the brake cylinders and lines.

The hydraulic system can be bled manually or with pressure bleeding equipment.

MANUAL BLEEDING

Bleed the longest lines first. Keep the master cylinder reservoir filled with new heavy-duty brake fluid during the bleeding operation.

Never use brake fluid which has been drained from the hydraulic system.

1. Position a bent $\frac{3}{8}$ -inch box wrench on the bleeder fitting on the right rear brake wheel cylinder (Fig. 4). Attach a rubber drain tube to the bleeder fitting. **The end of the tube should fit snugly around the bleeder fitting.**

2. Submerge the free end of the tube in a container partially filled with clean brake fluid, and loosen the bleeder fitting approximately $\frac{1}{4}$ turn.

3. Push the brake pedal down slowly thru its full travel. Close the bleeder fitting, then return the pedal to the fully-released position.

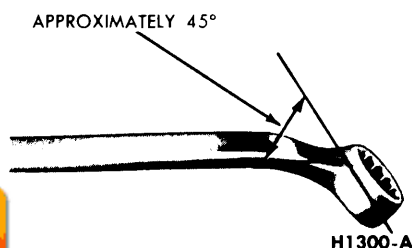

FIG. 4—Wrench for Bleeding Brake

Repeat this operation until air bubbles cease to appear at the submerged end of the tube.

4. When the fluid is completely free of air bubbles, close the bleeder fitting and remove the drain tube.

5. Repeat this procedure at each brake wheel cylinder in order: left rear, right front, and left front. Refill the master cylinder reservoir after each brake cylinder is bled and when the bleeding operation is completed. The fluid level should be within $\frac{3}{8}$ inch of the top of the reservoir.

PRESSURE BLEEDING

Bleed the longest lines first. **Never use brake fluid which has been drained from the hydraulic system.**

The bleeder tank should contain enough new heavy-duty brake fluid to complete the bleeding operation, and it should be charged with 10-30 pounds of air pressure.

1. Clean all dirt from the master cylinder reservoir cap.

2. Remove the master cylinder reservoir cap, install an adapter cap to the reservoir, and attach the bleeder tank hose to the fitting on the adapter cap.

Adapter cap 2162 can be used, or an adapter cap can be fabricated by cutting a hole in the center of a reservoir cap and soldering a fitting at the hole.

3. Position a $\frac{3}{8}$ -inch box wrench on the bleeder fitting on the right rear brake wheel cylinder (Fig. 4). Attach a rubber drain tube to the bleeder fitting. **The end of the tube should fit snugly around the bleeder fitting.**

4. Open the valve on the bleeder tank to admit pressurized brake fluid to the master cylinder reservoir.

5. Submerge the free end of the tube in a container partially filled with clean brake fluid, and loosen the bleeder fitting.

6. When air bubbles cease to appear in the fluid at the submerged end of the drain tube, close the bleeder fitting and remove the tube.

7. Repeat this procedure at each brake wheel cylinder in order: left rear, right front, and left front.

8. When the bleeding operation is completed, close the bleeder tank valve and remove the tank hose from the adapter fitting.

9. Remove the adapter cap, refill the master cylinder reservoir to within $\frac{1}{4}$ inch from the top of the reservoir, and install the reservoir cap.

BUY IT NOW!
[Click Here To Order](#)



3 CLEANING AND INSPECTION

BRAKE ASSEMBLY

1. Remove the wheel from the drum, and remove the drum as outlined in Part 2-2, Section 2. Wash all the parts except the brake shoes in a cleaning fluid and dry with compressed air.

2. Brush all dust from the carrier plate and interior of the brake drum.

3. Inspect the brake shoes for excessive lining wear or shoe damage. If the lining is worn to within $\frac{1}{32}$ inch of the rivet heads or if the shoes are damaged, they must be replaced. Replace any lining that has been oil saturated. Replace the lining in axle sets. Prior to replacement of the lining, the drum diameter should be checked to determine if oversize linings must be installed.

4. Check the condition of the brake shoes, retracting springs, and drum for signs of overheating. If the

shoes have a slight blue coloring, or if the springs show a change in free length, indicating overheating, replacement of the retracting and hold down springs is necessary. **Overheated springs lose their pull and could cause the new lining to wear prematurely if they are not replaced.**

5. If the car has 24,000 or more miles of operation on the brake linings, or signs of overheating are present when relining brakes, the wheel cylinders should be disassembled and inspected for wear and dirt in the cylinder. The cylinder cups should be replaced, thus avoiding future problems.

6. Inspect all other brake parts and replace any that are worn or damaged.

7. Inspect the brake drums and, if necessary, refinish. Refer to Part 2-2, Section 4 for refinishing.

BOOSTER UNIT

A disassembled view of the brake booster is shown in Fig. 5.

After disassembly, immerse all metal parts in a suitable solvent. Use only alcohol on rubber parts or parts containing rubber. After the parts have been thoroughly cleaned and rinsed in cleaning solvent, the metal parts which come in contact with hydraulic brake fluid or rubber parts should be rewashed in clean alcohol before assembly. Use an air hose to blow dirt and cleaning fluid from the recesses and internal passages. When overhauling a power booster, use all parts furnished in the repair kit. **Discard all old rubber parts.**

Inspect all other parts for damage or excessive wear. Replace damaged or excessively worn parts. If the inside of the booster body is rusted or corroded, polish it with steel wool or fine emery cloth. Replace the body shell when scored.

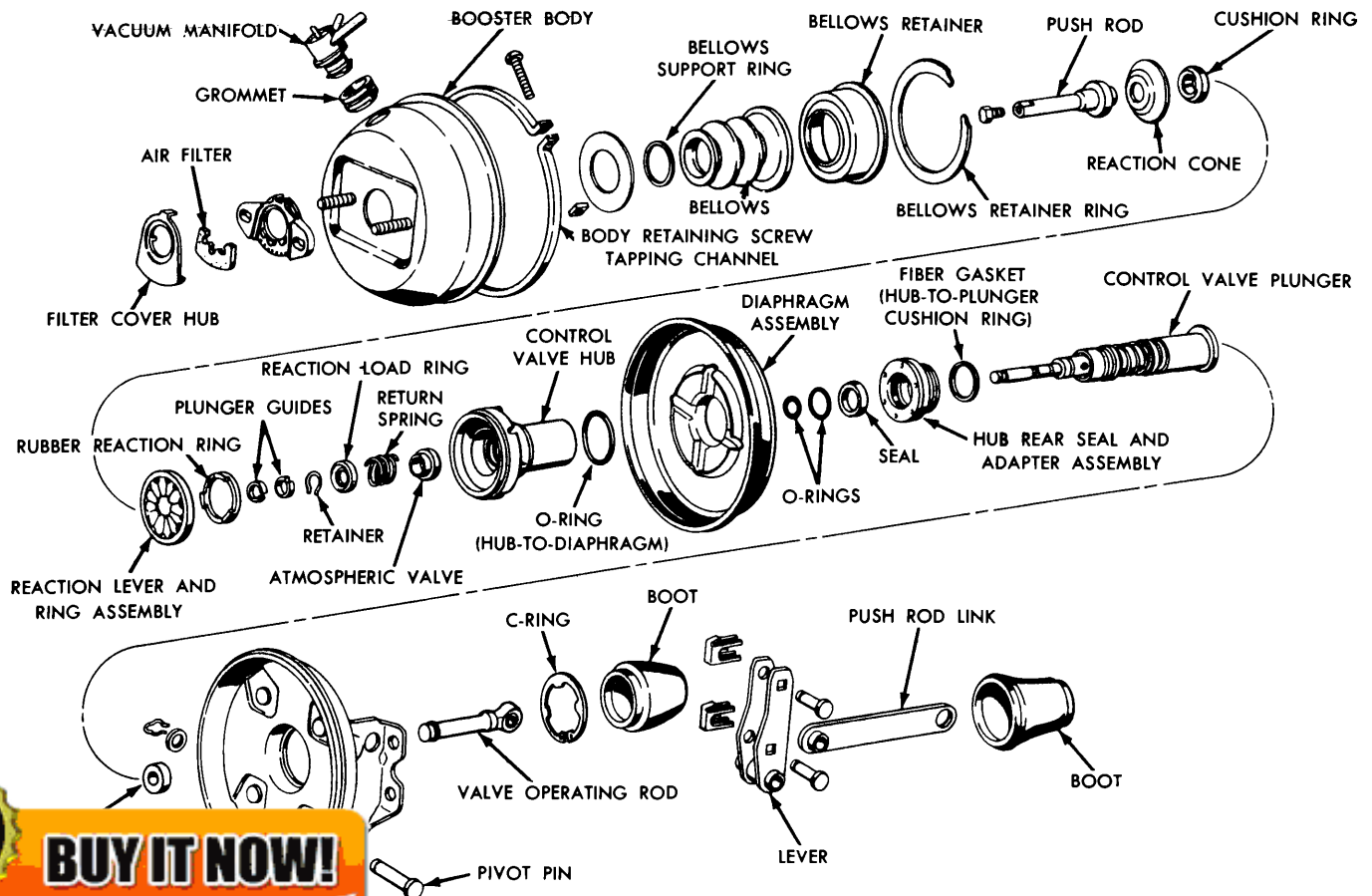

100% SATISFACTION GUARANTEED

BUY IT NOW!

Click Here To Order

PayPal, American Express, Discover, MasterCard, VISA

PART 2-2 BRAKE SYSTEM

Section	Page	Section	Page
1 Description and Operation	2-6	3 Removal and Installation	2-14
2 In-Car Adjustments and Repairs	2-9	4 Major Repair Operations	2-16

1 DESCRIPTION AND OPERATION

HYDRAULIC SELF-ADJUSTING BRAKE SYSTEM

The hydraulic brake system employs single anchor, internal expanding and self-adjusting brake assemblies, and is powered by a vacuum booster.

The master cylinder converts physical force from the brake pedal and booster into hydraulic pressure against the pistons in the wheel cylinders. The wheel cylinder pistons in turn convert hydraulic pressure back into physical force at the brake shoes.

The self-adjusting brake mechanism consists of a cable, cable guide, adjusting lever, adjuster spring, and adjuster screw (Fig. 1). The cable is hooked over the anchor pin at the top and is connected to the lever at the bottom. The cable is connected to the secondary brake shoe by means of the cable guide. The adjuster spring is hooked to the primary brake shoe and to the lever. The automatic adjuster operates only when the brakes are applied while the car is moving rearward and only when the secondary shoe is free to move toward the drum

beyond a predetermined point.

With the car moving rearward and the brakes applied, the "wrap-around" action of the shoes following the drum forces the upper end of the primary shoe against the anchor pin. The action of the wheel cylinder moves the upper end of the secondary shoe away from the anchor pin. The movement of the secondary shoe causes the cable to pull the adjusting lever upward and against the end of a tooth on the adjusting screw star wheel. The upward travel of the lever increases as lining wear increases. When the

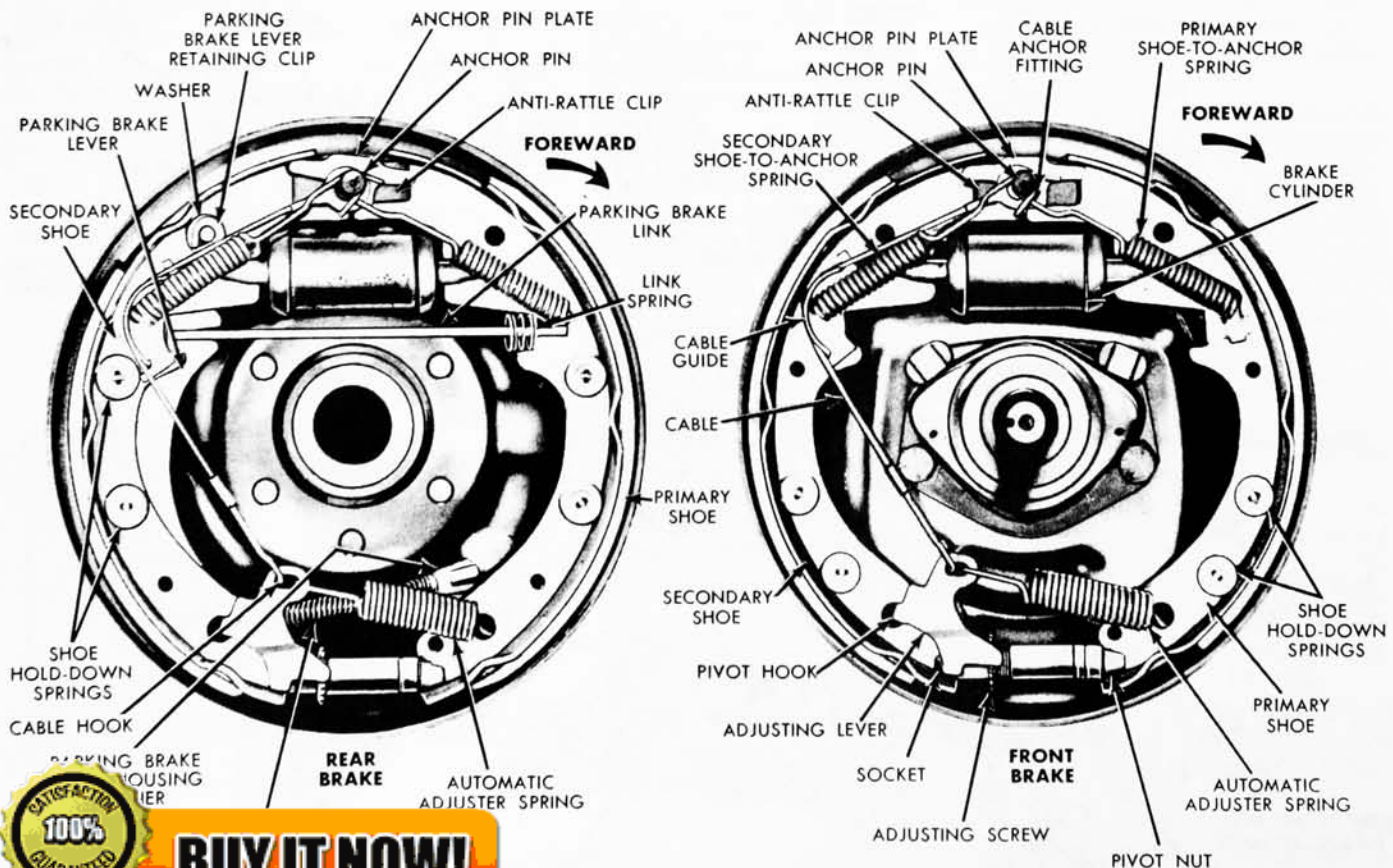

100% SATISFACTION GUARANTEED

BUY IT NOW!

Click Here To Order

lever can move upward far enough, it passes over the end of the tooth and engages the tooth. When the brakes are released, the adjusting spring pulls the lever downward causing the star wheel to turn and expand the shoes. The star wheel is turned one tooth at a time as the linings progressively wear.

With the car moving forward and the brakes applied, the secondary shoe is against the anchor pin and the primary shoe is moved toward the drum. Therefore, the adjuster does not operate.

The rear brake assembly is basically the same as the front brake. The conventional parking brake lever, link, and spring are used in the rear brake.

The anchor pins on all brakes are fixed and non-adjustable.

BOOSTER SYSTEM

The power brake booster is installed on the engine side of the dash panel and is connected to the brake pedal through a lever assembly and push rod link.

The booster consists of a vacuum chamber, atmospheric valve, control valve plunger assembly, diaphragm and an atmospheric chamber.

Atmospheric pressure is present at all times in the atmospheric chamber at the front side of the atmospheric valve. The air intake to the atmospheric chamber is protected by an air filter. The atmospheric chamber is separated from the vacuum chamber by the bellows assembly within the vacuum chamber.

Vacuum is present at all times in that area of the vacuum chamber forward of the diaphragm. Vacuum is supplied through a hose from the intake manifold to the vacuum manifold and check valve on the booster body. With this integral check valve and vacuum chamber, it is possible to obtain several power assisted brake applications with the engine shut off. This arrangement makes a vacuum reservoir unnecessary.

Either vacuum from the forward (from
ber)
e of
g in
the

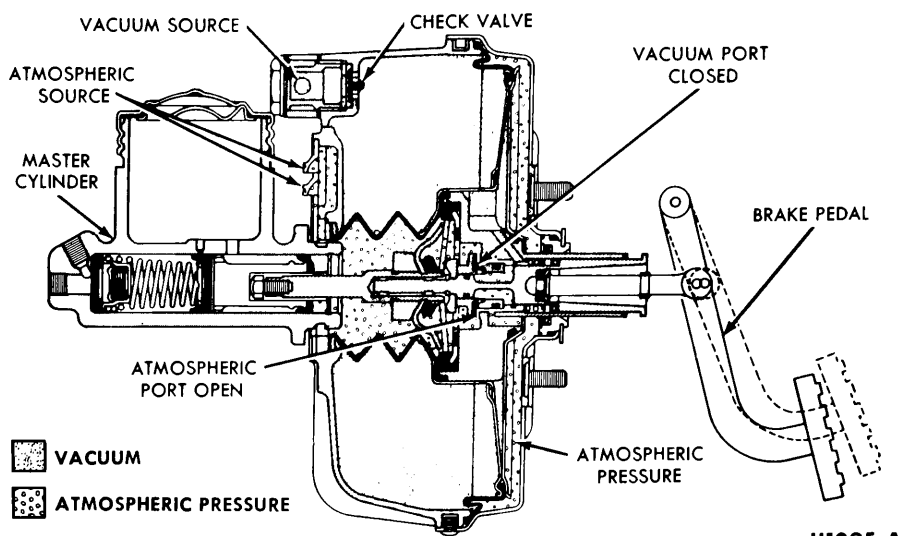

FIG. 2—Booster in Applied Position

APPLYING POSITION

As the brake pedal is depressed, the valve operating rod and valve plunger assembly move forward compressing the plunger return spring (Fig. 2). The initial movement of the plunger closes the porting from the vacuum chamber preventing further evacuation of the area back of the diaphragm. Further movement of the plunger forces the atmospheric valve off its seat so that atmospheric pressure from the bellows can enter the hub porting that leads to the rear side of the diaphragm.

With vacuum on the front side of the diaphragm and atmospheric pressure on the back side of the diaphragm, a force is developed to

move the diaphragm, push rod and master cylinder piston forward to close the compensating port and force hydraulic fluid under pressure through the residual pressure check valve and brake tubes to the wheel brakes. As hydraulic pressure is developed in the hydraulic system, a reaction counter-force acts against the reaction lever and ring assembly. This reaction lever and ring assembly is designed to transmit the reaction forces back through the actuating control valve assembly to the brake pedal and provide the driver with a resistance that is in proportion to the brake hydraulic apply forces. This is the means of providing the proper "driver feel" to the power brake unit.

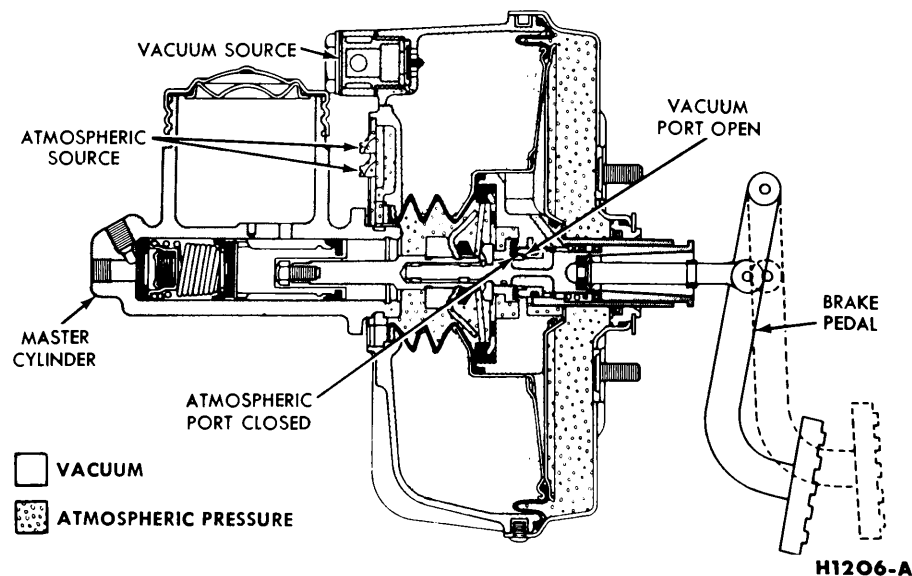

FIG. 3—Booster in Holding Position

100% SATISFACTION GUARANTEED

BUY IT NOW!

Click Here To Order

NUMBER ASSEMBLY

PayPal American Express Discover Novus MasterCard VISA

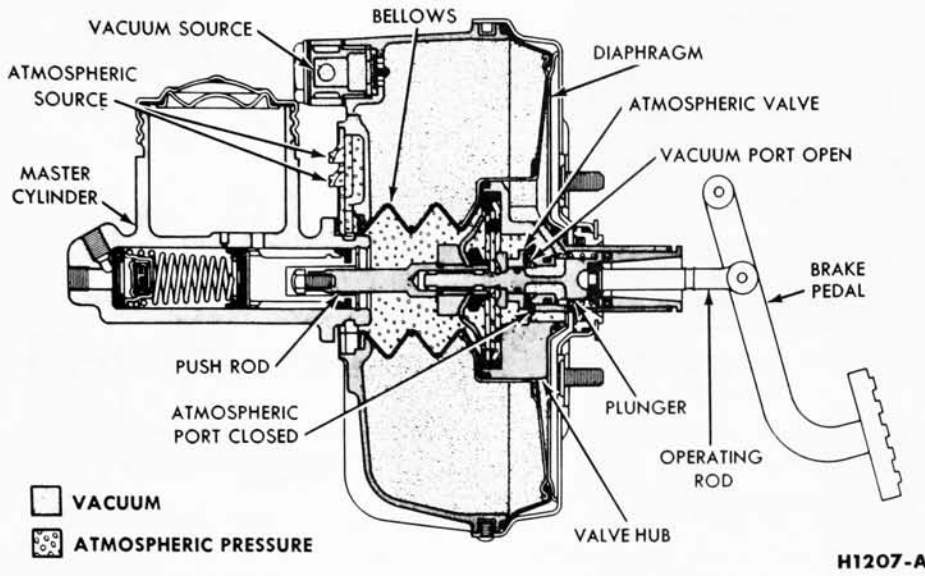

FIG. 4—Booster in Released Position

HOLDING POSITION

When the forward motion of the brake pedal is stopped and held, the valve operating rod ceases to move the control valve plunger forward. However, the unbalanced forces of atmospheric pressure and vacuum on each side of the diaphragm will continue to move the outer sleeve of the control valve plunger forward keeping the vacuum porting closed. At the same time, the reaction force acting through the reaction ring and lever assembly will tend to move the atmospheric valve

to the closed position (Fig. 3). When these combined forces balance, the porting to the vacuum supply will remain closed and the atmospheric valve will cut off any further passage of atmospheric pressure to the area behind the diaphragm. Therefore, the power assist force acting on the master cylinder piston will stabilize and the hydraulic force applying the brakes will be maintained at a constant level.

RELEASED POSITION

When the pedal pressure is released from the valve operating rod

and plunger assembly, the plunger return spring moves the plunger away from the atmospheric valve allowing the valve to seat against the hub (Fig. 4). This seating of the valve closes off the bellows chamber from the hub porting that connects to the rear side of the diaphragm. At the same time, the rearward movement of the plunger opens the porting from the vacuum chamber and draws out the air from the rear side of the power diaphragm. With vacuum on both sides of the diaphragm, the assist force against the master cylinder push rod is eliminated. The brake shoe retracting springs will, therefore, cause the hydraulic fluid to return the master cylinder piston, push rod, control valve plunger assembly and the diaphragm to the released position.

With the piston and push rod in the released position, the hydraulic compensating port in the master cylinder is open. The open port permits fluid either to return from the brake system to the fluid reservoir, or enter the brake system from the reservoir.

PARKING BRAKES

An independent foot-operated parking brake control actuates the rear wheel brake shoes through a cable linkage. The operating cable is routed from the parking brake control assembly to the equalizer lever which is attached to the equalizer assembly. The rear brake cables connect the equalizer assembly to the parking brake lever at each rear secondary shoe (Fig. 1, Part 2-1 and Fig. 15).

When the pedal is depressed the secondary brake shoes are forced against the rear brake drums. The pedal is held in the applied position by the engagement of a spring-loaded pawl with a ratchet in the control assembly.

A vacuum power unit will release the parking brakes automatically when the transmission selector lever is moved into any drive position with the engine running. The brakes will not release automatically, however, when the selector lever is in the neutral or park position with the engine running, or in any position with the engine off.

The parking brake control assembly is mounted to the left cowl side panel (Fig. 15). The pedal as-



100% SATISFACTION GUARANTEED

BUY IT NOW!

[Click Here To Order](#)

PayPal, American Express, Discover, MasterCard, VISA

sembly pivots on a stationary pedal mount (Fig. 5). A spring-loaded pawl and a release lever are assembled to the pedal. A ratchet is assembled to the stationary mount. The pawl contacts the ratchet at such an angle that it will slide over the ratchet teeth as the pedal is depressed; however, when the applying motion stops and the pedal starts to release, the pawl engages the ratchet and thus locks the brakes in the applied position. Since the release lever pivots against the pawl, a slight movement of the release lever will disengage the pawl from the ratchet allowing the brakes to release. The release lever is actuated by a manual release handle which is connected to the lever through a slot and rivet pin (Fig. 5).

The vacuum power unit with mounting bracket is riveted to the

control assembly. The vacuum actuated piston within the unit is connected by a link to the upper end of the release handle which actuates the release lever to move the pawl out of engagement with the ratchet (Fig. 5). The lower end of the release handle extends out for alternate manual release in the event of vacuum power failure or for optional manual release at any time.

Hoses connect the power unit and the engine manifold to a vacuum release valve in the transmission neutral safety switch (Figs. 5 and 6). Moving the transmission selector lever into any drive position with the engine running will open the release valve to connect engine manifold vacuum to one side of the actuating piston in the power unit. The pressure differential thus created will cause the piston and link to pull

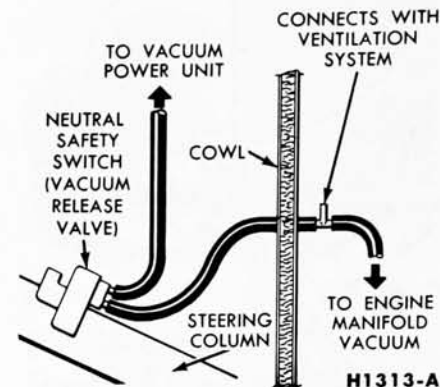

FIG. 6—Vacuum Connections for Automatic Parking Brake Release

the manual release handle which, in turn, actuates the release lever.

2 IN-CAR ADJUSTMENTS AND REPAIRS

BRAKE SHOE ADJUSTMENTS

The car should be raised with the wheels off the floor. **If the car is raised on a frame-contact hoist, disconnect the parking brake cables to prevent the rear brakes from being partially applied due to rear axle and spring sag on the hoist.**

The hydraulic service brakes are self-adjusting and require a manual adjustment only after the brake shoes have been relined, replaced, or when the length of the adjusting screw has been changed while performing some other service operation.

The brake drums should be at normal room temperature when adjusting the brake shoes. If the shoes are adjusted when the drums are hot and expanded, the shoes may drag when the drums are cool and contracted.

1. After the shoes have been installed or the adjusting screw has been turned, install the drum. Be sure that all excess grease, oil, and other foreign material are wiped off the carrier plate and drum.

Before installing the brake drum

wipe the carrier plate and drum with a clean cloth. Be sure that the drum is clean and free of any

cover from the carrier plate and, from the carrier plate side, turn the adjusting screw upward to expand the shoes (Fig. 7). Expand the shoes until a drag is felt when the drum is rotated.

3. Remove the drum. Mark the tooth on the star wheel where the lever contacts the adjusting screw. While holding the adjusting lever out of engagement with the adjusting screw, back off the adjusting screw $\frac{3}{4}$ of a turn with the fingers. If finger movement will not turn the screw, free it up; otherwise, the self-adjusting lever will not turn the screw. Lubricate the screw with a thin uniform coating of high-temperature grease (see Specifications).

Any other adjustment procedure may cause damage to the adjusting screw with consequent self-adjuster problems.

4. Apply a small quantity of high-temperature grease to the points where the shoes contact the carrier plate, being careful not to get the lubricant on the linings. Install the drum.

On a front wheel, install the wheel outer bearing, washer, and adjusting nut, then adjust the wheel bearings as outlined in Part 3-4, Section 2.

On a rear wheel, install the three Tinnerman nuts and tighten securely.

5. Install the wheel on the drum

and tighten the mounting nuts to specification.

6. Install the adjusting hole cover on the brake carrier plate.

7. When adjusting the rear brake shoes, check the parking brake cables for proper adjustment. Make sure that the equalizer lever operates freely.

8. After the brake shoes have been properly adjusted, check the operation of the brakes.

FRONT BRAKE DRUM REMOVAL

1. Raise the car until the wheel and tire clear the floor. Remove the



Brake Shoe Adjusting Tool

H1153-A

FIG. 7—Expanding Brake Shoes

100% SATISFACTION GUARANTEED

BUY IT NOW!

Click Here To Order

PayPal, American Express, Discover, MasterCard, VISA

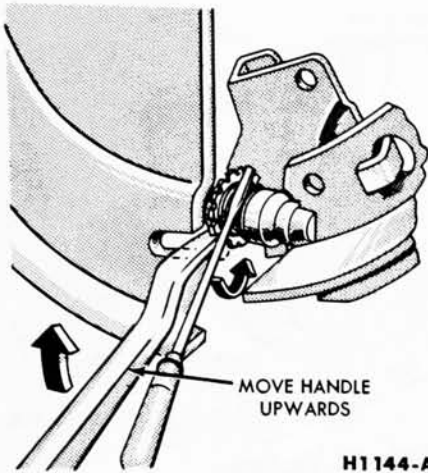

FIG. 8—Backing off Brake Adjustment

wheel cover or hub cap, and remove the wheel and tire assembly from the drum.

2. Remove the grease cap from the hub. Remove the cotter pin, nut lock, adjusting nut, and flat washer from the spindle. Remove the outer bearing cone and roller assembly.

3. Pull the hub and drum assembly off the wheel spindle. If the brake drum will not come off easily, insert a narrow screwdriver through the brake adjusting hole in the carrier plate, and disengage the adjusting lever from the adjusting screw. While holding the adjusting lever away from the screw, back off the adjusting screw with the brake adjusting tool (Fig. 8). **Back off the adjustment only if the drum cannot be removed. Be very careful not to burr, chip, or damage the notches in the adjusting screw; otherwise the self-adjusting mechanism will not function properly.**

INSTALLATION

1. If the drum is being replaced, remove the protective coating from the new drum with carburetor degreaser. Install new bearings and grease retainer. Soak the new grease retainer in light engine oil at least 30 minutes before installation. Pack the wheel bearings, install the inner bearing cone and roller assembly in the hub, install the hub cap, and install the new drum. See Part 3-4, Section 2.

lined under "Brake Shoe Adjustments" in this section. Make sure the adjusting lever is properly seated in the shoe web.

3. Install the outer wheel bearing, washer and adjusting nut.

4. Adjust the wheel bearing as outlined in Part 3-4, Section 2, then install the nut lock, cotter pin, and grease cap. Install the wheel and hub cap.

REAR BRAKE DRUM REMOVAL

1. Raise the car until the wheel and tire clear the floor.

2. Remove the hub cap and wheel. Remove the three Tinnerman nuts and remove the brake drum. If the brake drum will not come off easily, insert a narrow screwdriver through the brake adjusting hole in the carrier plate, and disengage the adjusting lever from the adjusting screw. While holding the adjusting lever away from the adjusting screw, back off the adjusting screw with the brake adjusting tool (Fig. 8). **Back off the adjustment only if the drum cannot be removed. Be very careful not to burr, chip, or damage the notches in the adjusting screw; otherwise, the self-adjusting mechanism will not function properly.** If the adjustment was changed, make certain that the adjuster lever is seated in the shoe web.

INSTALLATION

1. Remove the protective coating from a new drum with carburetor degreaser.

2. Place the drum over the brake assembly and into position. If required, adjust the brakes as outlined under "Brake Shoe Adjustments" in this section. Make sure the adjusting lever is properly seated in the shoe web.

3. Install the three Tinnerman nuts and tighten securely. Install the wheel on the axle shaft flange studs against the drum, and tighten the retaining nuts to specifications. Install the hub cap.

BRAKE SHOES AND ADJUSTING SCREW

REMOVAL

1. Remove the wheel and the brake drum.

2. Contract the shoes as follows:

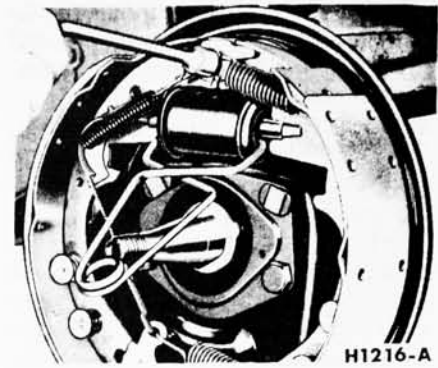

FIG. 9—Retracting Spring Removal

a. Disengage the adjusting lever from the adjusting screw by pulling backward on the adjusting lever (Fig. 1).

b. Move the outboard side of the adjusting screw upward and back off the pivot nut as far as it will go.

3. Pull the adjusting lever, cable and automatic adjuster spring down and toward the rear to unhook the pivot hook from the large hole in the secondary shoe web. **Do not attempt to pry the pivot hook out of the hole.**

4. Remove the automatic adjuster spring and adjusting lever (Fig. 1).

5. Remove the primary shoe to anchor spring with the tool shown in Fig. 9. With the same tool, remove the secondary shoe to anchor spring and unhook the cable eye from the anchor pin.

6. Remove the anchor pin plate and the anti-rattle clip.

7. Remove the cable guide from the secondary shoe (Fig. 1).

8. Remove the shoe hold-down springs, shoes, adjusting screw, pivot nut, and socket.

9. On rear brakes, remove the parking brake link and spring. Disconnect the parking brake cable from the parking brake lever.

10. After removing the rear brake secondary shoe, disassemble the parking brake lever from the shoe by removing the retaining clip and spring washer (Fig. 1).

INSTALLATION

1. Before installing the rear brake shoes, back off the parking brake adjustment. Then assemble the parking brake lever to the secondary shoe and secure with the spring washer and retaining clip.

2. Apply a light coating of high-temperature grease at the points

100% SATISFACTION GUARANTEED

BUY IT NOW!

Click Here To Order

Adjust the brakes as outlined in Part 3-4, Section 2.

PayPal American Express Discover Novus MasterCard VISA

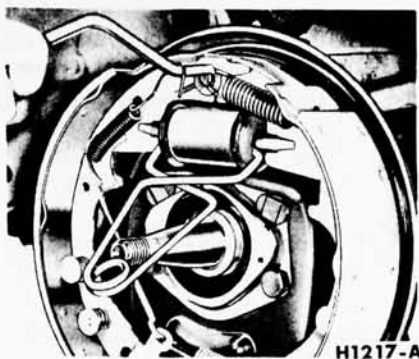

FIG. 10—Retracting Spring Installation

where the brake shoes contact the carrier plate.

3. Position the brake shoes on the carrier plate and secure the assembly with the hold-down springs. On the rear brake, install the parking brake link and spring. Connect the parking brake cable to the parking brake lever (Fig. 1).

4. Install the anti-rattle clip and the anchor pin plate on the anchor pin.

5. Place the cable eye over the anchor pin with the crimped side toward the carrier plate.

6. Install the secondary shoe to anchor spring (Fig. 10).

7. Install the cable guide on the secondary shoe web with the flanged hole properly fitted into the hole in the secondary shoe web. Thread the cable around the cable guide groove (Fig. 1).

It is imperative that the cable be positioned in this groove and not between the guide and the shoe web.

8. Install the primary shoe to anchor spring with the tool shown in Fig. 10.

Be certain that the cable eye is not cocked or binding on the anchor pin when installed. All parts should be flat on the anchor pin.

9. Apply high-temperature grease (Stanalube Moly Grease Grade 2) to the threads and the socket end of the adjusting screw. Turn the adjusting screw into the adjusting pivot nut to the limit of the threads and then back off $\frac{1}{2}$ turn.

Interchanging the brake shoe

BUY IT NOW!

Click Here To Order

mechanism operated to prevent

stallation on the wrong side of the car, the socket end of the adjusting screw is stamped with an R or L (Fig. 11). The adjusting pivot nuts can be distinguished by the number of grooves machined around the body of the nut. Two grooves indicate a right hand nut; one groove indicates a left hand nut.

10. Place the adjusting socket on the screw and install this assembly between the shoe ends with the adjusting screw toothed wheel nearest the secondary shoe.

11. Hook the cable hook into the hole in the adjusting lever. The adjusting levers are stamped with an R or L to indicate their installation on a right or left hand brake assembly (Fig. 11).

12. Position the hooked end of the adjuster spring completely into the large hole in the primary shoe web. The last coil of the spring should be at the edge of the hole. Connect the loop end of the spring to the adjuster lever hole.

13. Pull the adjuster lever, cable and automatic adjuster spring down and toward the rear to engage the pivot hook in the large hole in the secondary shoe web (Fig. 1).

14. After installation, check the action of the adjuster by pulling the section of the cable between the cable guide and the adjusting lever toward the secondary shoe web far enough to lift the lever past a tooth on the adjusting screw wheel. The lever should snap into position behind the next tooth, and release of the cable should cause the adjuster spring to return the lever to its original position. This return action of the lever will turn the adjusting screw one tooth.

If pulling the cable does not produce the action described, or if the lever action is sluggish instead of positive and sharp, check the position of the lever on the adjusting screw toothed wheel. With the brake in a vertical position (anchor at the top), the lever should contact the adjusting wheel $\frac{3}{16}$ inch (plus or minus $\frac{1}{32}$ inch) above the centerline of the screw. If the contact point is below this centerline, the lever will not lock on the teeth in the adjusting screw wheel, and the screw will not be turned as the lever is actuated by the cable.

To determine the cause of this condition:

a. Check the cable end fittings. The cable should completely fill or

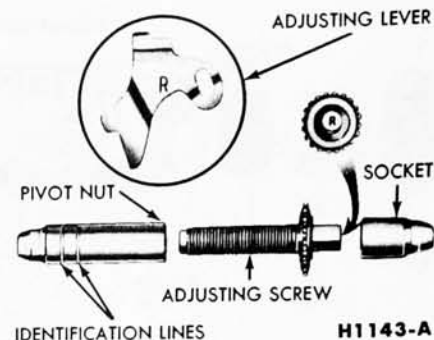

FIG. 11—Adjusting Screw and Lever Identification

extend slightly beyond the crimped section of the fittings. If it does not meet this specification, possible damage is indicated and the cable assembly should be replaced.

b. Check the cable length. The cable should measure $11\frac{1}{8}$ inches (plus or minus $\frac{1}{64}$ inch) from the end of the cable anchor to the end of the cable hook.

c. Check the cable guide for damage. The cable groove should be parallel to the shoe web, and the body of the guide should lie flat against the web. Replace the guide if it shows damage.

d. Check the pivot hook on the lever. The hook surfaces should be square with the body of the lever for proper pivoting. Replace the lever if the hook shows damage.

e. See that the adjusting screw socket is properly seated in the notch in the shoe web.

WHEEL CYLINDER REPAIR

DISASSEMBLY

1. Remove the links and the rubber boots from the ends of the brake cylinder. Remove the pistons, cups, and return spring from the cylinder bore (Fig. 12).

2. Remove the bleeder screw from the cylinder.

INSPECTION

1. Wash all parts in clean denatured alcohol. If alcohol is not available, use specified brake fluid. Dry with compressed air.

2. Check all internal parts for excessive wear or damage. **If any of the internal parts require replacing, all should be replaced.**

3. Inspect the cylinder bore for score marks or rust. If either condition is present, the cylinder bore



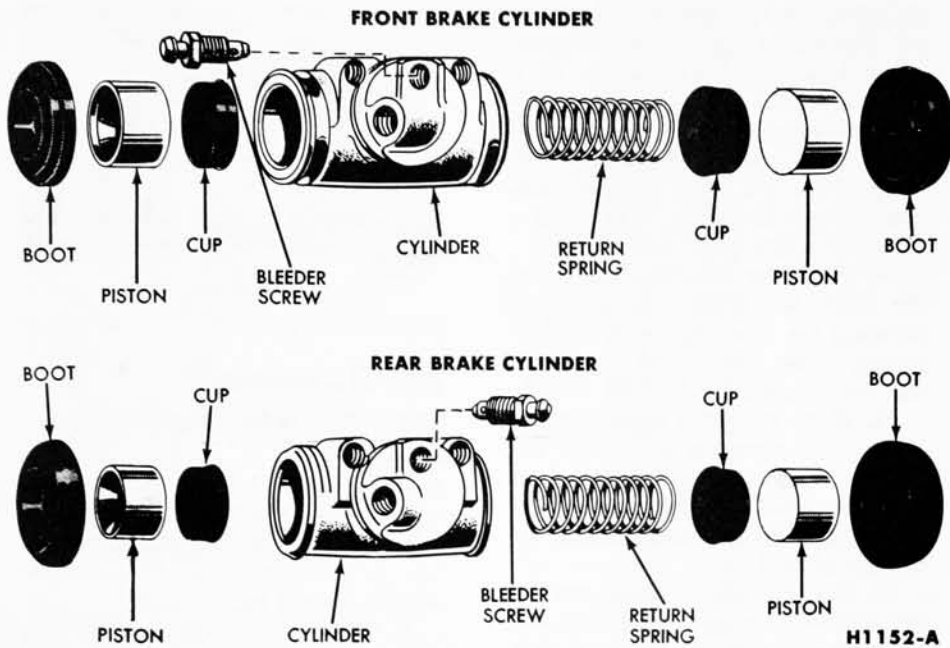

FIG. 12—Front and Rear Brake Wheel Cylinders

must be honed. However, the cylinder should not be honed more than 0.003 inch beyond its original diameter.

4. Check the bleed hole to be sure that it is open.

ASSEMBLY

1. Apply a coating of heavy-duty brake fluid to all internal parts.
2. Thread the bleeder screw into the cylinder and tighten securely.
3. Insert the return spring, cups, and pistons into their respective positions in the cylinder bore (Fig. 12). Place a boot over each end of the cylinder.

WHEEL CYLINDER REPLACEMENT

REMOVAL

1. With the wheel in a raised position, remove the wheel and the drum.
2. Remove the brake shoe assemblies, following procedures outlined in this section.
3. Disconnect the brake line from the brake cylinder. **Be sure the engine is stopped and there is no vacuum in the booster system before disconnecting the hydraulic**

on the frame. Remove the horseshoe-type retaining clip from the hose and bracket, disengage the hose from the bracket, then unscrew the entire hose assembly from the front brake cylinder.

At a rear cylinder, unscrew the tube fitting that connects the tube to the cylinder. **Do not pull the metal tube away from the cylinder. Pulling the tube out of the cylinder connection will bend the metal tube and make installation difficult.** The tube will separate from the cylinder when the cylinder is removed from the carrier plate.

4. Remove the brake cylinder retaining bolts and lock washers and remove the cylinder.

INSTALLATION

Wipe the end(s) of the hydraulic line to remove any foreign matter before making connections.

1. To install a front cylinder:

- a. Insert a front cylinder into the opening on the carrier plate with the inlet toward the rear of the car. Install the retaining bolts and lock washers.
- b. Install a new copper gasket over the hose fitting. Screw the hose assembly into the cylinder.

- c. Engage the opposite end of the hose to the bracket on the frame, install the horseshoe-type retaining clip, and connect the brake tube to the hose with the tube fitting nut. Tighten the nut to specification with Milbar tool 1112-144 or its equivalent.

2. To install a rear cylinder:

- a. Place the rear wheel cylinder into position. Enter the tubing into the cylinder, and start the tube fitting nut into the threads of the cylinder.
- b. Secure the cylinder to the carrier plate by installing the retaining bolts and lock washers.
- c. Tighten the tube fitting nut to specification with Milbar tool 1112-144 or its equivalent.

3. Bleed the brake hydraulic system as detailed in Section 2.

BRAKE CARRIER PLATE REPLACEMENT

REMOVAL

1. Remove the wheel and brake drum. Disconnect the brake line from the brake cylinder.
2. Remove the brake shoe and adjuster assemblies and the wheel cylinder as outlined in this section. On the rear wheel, disconnect the parking brake lever from the cable.
3. If the rear carrier plate is being replaced, rotate the axle shaft so that the hole in the axle shaft flange lines up with the carrier plate retaining nuts and remove the nuts. Pull the axle shaft assembly out of the housing with tool-4235C and a slide hammer (Part 4-2), and then remove the carrier plate.

If the front carrier plate is being replaced, remove the bolts and nuts that secure the plate to the front wheel spindle and remove the plate.

INSTALLATION

1. Position a new rear carrier plate on the retaining bolts in the axle housing flange. Insert the axle shaft into the housing so that the splines engage the differential side gear with the bearing retainer sliding onto the retaining bolts and against the carrier plate. Install the retaining nuts

BUY IT NOW!
 Click Here To Order







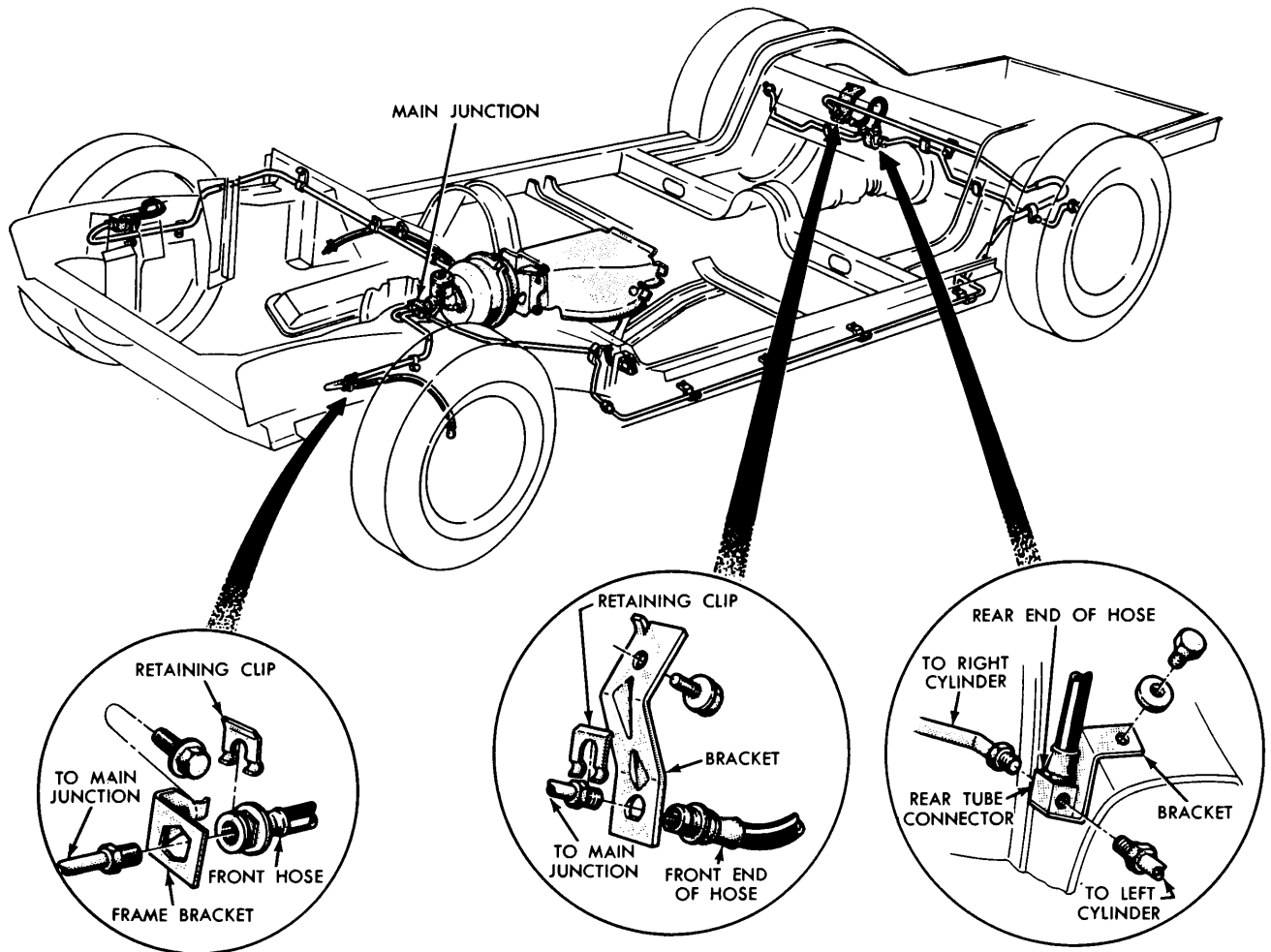

H1310-A

FIG. 13—Service Brake System

through the access hole in the axle shaft flange.

Position a new front carrier plate to the wheel spindle and install the retaining bolts and nuts.

2. Install the wheel cylinder and connect the brake line as outlined in this section.

3. Install the brake shoe and adjuster assemblies as outlined in this section. On a rear brake, connect the parking brake cable to the lever. Install the brake drum and wheel.

4. Adjust the brake shoes (Section 2), and bleed the brake system as outlined in Part 2-1, Section 2.

HYDRAULIC LINES

Steel tubing is used throughout the brake system with the exception of the front

BRAKE TUBE REPLACEMENT

If a section of the brake tubing becomes damaged, the entire section should be replaced with tubing of the same type, size, shape, and length. **Copper tubing should not be used in a hydraulic system.** When bending brake tubing to fit underbody or rear axle contours, be careful not to kink or crack the tube.

All brake tubing should be flared properly to provide good leak-proof connections. Clean the brake tubing by flushing with clean denatured alcohol, before installation.

When connecting a tube to a hose, tube connector, or brake cylinder, tighten the tube fitting nut to the specified torque with Milbar tool 1112-144 or equivalent.

BRAKE HOSE REPLACEMENT

A flexible brake hose should be replaced if it shows signs of soften-

ing, cracking, or other damage.

When installing a new front brake hose, position the hose to avoid contact with other chassis parts. Place a new copper gasket over the hose fitting and screw the hose assembly into the front brake cylinder. Place the opposite end of the hose at the bracket on the frame. Install the horseshoe-type retaining clip, and connect the tube to the hose with the tube fitting nut (Fig. 13).

A rear brake hose should be installed so that it does not touch the muffler outlet pipe or shock absorber.

Place a new gasket over the rear hose fitting and screw the hose assembly into the rear brake tube connector. Place the front end of the hose at the bracket on the frame. Install the horseshoe-type retaining clip, and connect the tube to the hose with the tube fitting nut.

100% SATISFACTION GUARANTEED

BUY IT NOW!

Click Here To Order

em
re-

PayPal American Express Discover Novus MasterCard VISA

3 REMOVAL AND INSTALLATION

MASTER CYLINDER

REMOVAL

1. Disconnect the two wires from the stop light switch at the brake master cylinder (Fig. 14).
2. Disconnect the three brake lines from the master cylinder outlet (main junction) fitting.
3. Remove the two master cylinder attaching nuts and lock washers, then remove the master cylinder from the booster unit.
4. Remove the rubber seal from the groove in the master cylinder.

INSTALLATION

1. Transfer the stop light switch and the main junction tube fitting to the replacement master cylinder.
2. Before installing the master cylinder, check the distance from the outer end of the push rod to the master cylinder mounting surface on the booster body (Fig. 4, Part 2-1). If the push rod dimension is not correct, see "Master Cylinder Push Rod Adjustment," Part 2-1, Section 2.
3. Install the rubber seal in the groove of the master cylinder housing, and install the master cylinder over the push rod onto the two studs that are integral with the booster body. Install the lock washers and re-

taining nuts. Torque to specification.

4. Connect the three brake lines to the outlet (main junction) tube fitting, but leave the line fitting nuts loose (Fig. 14).

5. Fill the master cylinder to $\frac{3}{8}$ inch below the top, and apply pressure to the brake pedal several times to expel air at the brake line fitting. Tighten the line fitting nuts.

6. Install the filler cap, wipe off excess fluid, and connect the two wires to the stop light switch.

BOOSTER UNIT

REMOVAL

1. Open the hood, and disconnect the wires from the stop light switch at the brake master cylinder (Fig. 14).
2. Disconnect the brake lines at the master cylinder outlet (main junction) tube fitting.
3. Disconnect the manifold vacuum hose from the booster unit. Disconnect the transmission vacuum throttle valve hose from the booster.
4. Working inside the car below the instrument panel, disconnect the booster push rod link from the brake pedal assembly. To do this, remove the horseshoe-type retaining clip and slide the push rod link and bush-

ings off the pin that is integral with the pedal. (Fig. 14).

5. Remove the four bracket-to-dash panel retaining nuts and washers.

6. Remove the booster and bracket assembly from the dash panel, sliding the push rod link out from the engine side of the dash panel (Fig. 14).

INSTALLATION

1. Mount the booster and bracket assembly to the dash panel by sliding the bracket mounting studs and the push rod link in through the holes in the dash panel (Fig. 14).

2. Working inside the car below the instrument panel, install the mounting bracket-to-dash panel retaining nuts and washers. Connect the booster push rod link to the brake pedal assembly. To do this, slide the push rod link and bushings onto the pin that is integral with the pedal. Secure the link to the pin with a horseshoe-type retaining clip (Fig. 14).

3. Connect the manifold vacuum hose to the booster. Connect the transmission vacuum throttle valve hose.

4. Connect the brake lines to the master cylinder outlet fitting, and connect the wires to the stop light switch.

5. Bleed the brake system.

BRAKE PEDAL

REMOVAL

1. Remove the C-washer that retains the push rod link to the brake pedal assembly (Fig. 14).
2. Remove the retainer and spring washer from the right end of the brake pedal pivot pin, slide the pivot pin out of the brake pedal and bracket, and remove the pedal.

INSTALLATION

1. Install the pivot pin bushings on the replacement pedal assembly, lift the pedal assembly into position in the mounting bracket, and slide the pivot pin through the pedal and bracket from the left side.

2. Install the spring washer and secure the pivot pin by installing the retainer in the groove at the right end of the pin (Fig. 14).

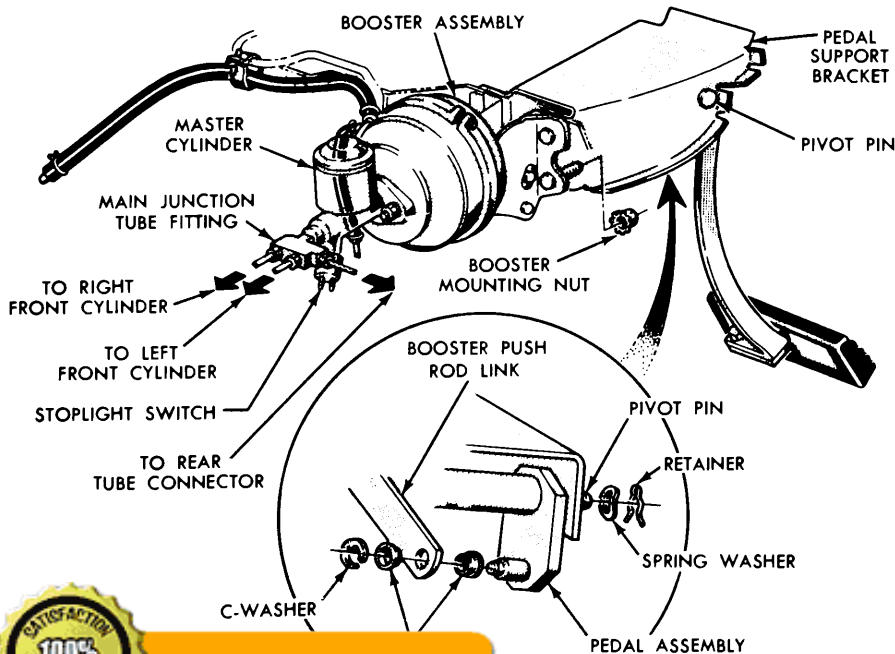

H1311-A

Pedal Installation

100% SATISFACTION GUARANTEED

BUY IT NOW!

Click Here To Order

PayPal, American Express, Discover, MasterCard, VISA

3. Connect the push rod link and bushings to the pedal assembly and secure with the C-washer.

PARKING BRAKE CONTROL ASSEMBLY

REMOVAL

1. Raise the car on a hoist and disconnect the pedal cable from the equalizer lever by removing the adjusting nut (Fig. 1, Part 2-1). Remove the U-clip and disengage the cable housing from the bracket.

2. Lower the car. In the passenger compartment, remove the retaining screws and the left kick pad. Remove the four screws that retain the air duct to the inner cowl panel, and then remove the air duct to obtain access to the brake control assembly. Remove the control cable from the air duct.

3. Disconnect the hose from the vacuum power unit.

4. Remove the control assembly-to-mounting bracket bolts.

5. Remove the U-clip that retains the cable housing to the parking brake control housing (Fig. 15).

6. Remove the hairpin retainer and clevis pin from the clevis. Disengage the clevis from the ball end of the cable, then remove the control assembly from the cable and cable housing.

INSTALLATION

1. Position the cable through the hole in the parking brake control housing. Install the clevis on the ball end of the cable and connect the clevis to the actuating arm with the clevis pin (Fig. 15). Secure the clevis pin with the hairpin retainer.

2. Secure the cable housing to the parking brake control housing with the U-clip.

3. Position the parking brake control assembly to the mounting bracket and install the three retaining bolts.

4. Connect the vacuum hose to the vacuum power unit.

5. Position the air duct to the inner cowl panel, and secure with four retaining screws. Connect the air duct control cable to the air duct. Position the left kick pad to the

side panel and secure with two retaining screws.

6. Raise the car on a hoist. Engage the cable housing to the frame bracket with a U-clip (Fig. 1, Part 2-1). Install the spring seat, cable spring and washer on the rear end of the cable. Assemble the cable to the equalizer lever and install the half-moon type adjusting nut on the end of the cable.

7. Adjust the parking brake linkage as outlined in Part 2-1, Section 2, and then check the operation of the parking brake.

PARKING BRAKE VACUUM POWER UNIT

REMOVAL

1. Remove the parking brake control assembly from the car as described under "Removal" in the foregoing procedure.

2. Drill out or grind off the two rivets that retain the vacuum power unit to the parking brake control assembly.

3. Drill out or grind off the rivet that connects the vacuum piston link

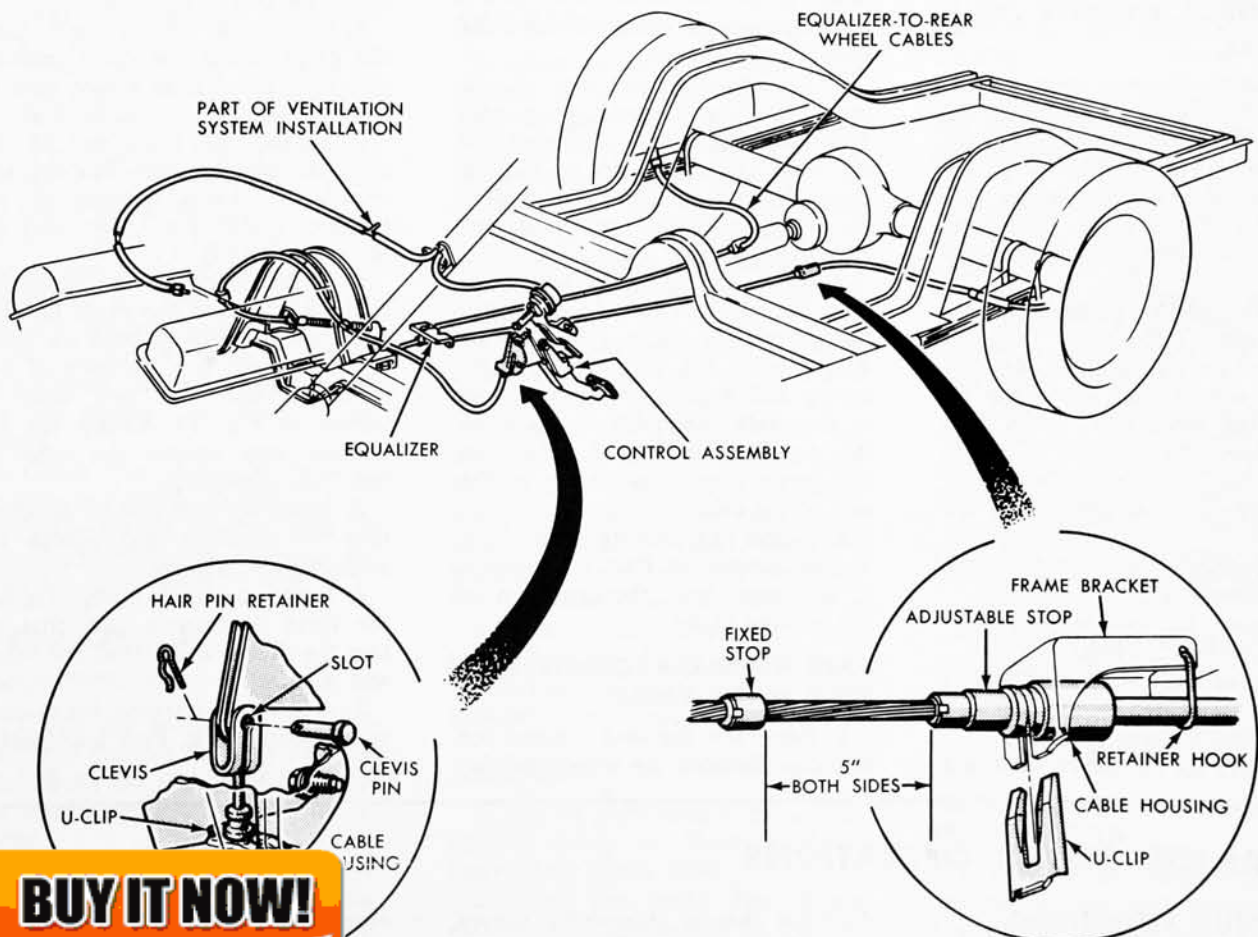

BUY IT NOW!

Click Here To Order



to the release lever, and remove the power unit.

INSTALLATION

1. Position the vacuum power unit on the parking brake control assembly and secure with two round head bolts and nuts.

2. Connect the vacuum piston link to the release lever with a shoulder bolt nut and wave washer. The wave washer is to be positioned on the shoulder bolt between the vacuum piston link and the release lever. The link and release lever must pivot freely.

3. Install the parking brake control assembly in the car as described under "Installation" in the foregoing procedure.

4. Test the lock and automatic release operations of the parking brake control assembly with the engine running in all the transmission selector lever positions. With the engine running, the parking brake should remain engaged in "neutral" or "park" and should release in any drive position.

PARKING BRAKE EQUALIZER-TO-CONTROL ASSEMBLY CABLE REMOVAL

1. Raise the car on a hoist and disconnect the pedal cable from the equalizer lever by removing the adjusting nut (Fig. 1, Part 2-1). Remove the cable washer, spring, and spring seat. Remove the U-clip and disengage the cable housing from the bracket.

2. Lower the car. In the passenger compartment, remove the retaining screws and the left kick pad. Remove the four screws that retain the air duct to the inner cowl panel, and then remove the air duct to obtain access to the brake control assembly. Remove the control cable from the air duct.

3. Disconnect the hose from the vacuum power unit.

4. Remove the control assembly-to-mounting bracket bolts.

5. Remove the U-clip that retains the cable housing to the parking brake control housing (Fig. 15).

6. Remove the hairpin retainer and

clevis pin from the clevis. Disengage the clevis from the ball end of the cable. Remove the control assembly from the cable and cable housing.

7. Push the cable and housing down through the hole in the floor pan and remove it from under the car.

INSTALLATION

1. From the underside of the car, guide the upper end of the replacement cable into the hole in the floor pan.

2. From the inside, pull the new cable and housing up through the hole in the floor pan.

3. Position the cable through the hole in the parking brake control housing. Install the clevis on the ball end of the cable and connect the clevis to the actuating arm with the clevis pin (Fig. 15). Secure the clevis pin with the hairpin retainer.

4. Secure the cable housing to the parking brake control housing with the U-clip.

5. Position the parking brake control assembly to the mounting bracket and install the three retaining bolts.

6. Connect the vacuum hose to the vacuum power unit.

7. Position the air duct to the inner cowl panel, and secure with four retaining screws. Connect the air duct control cable to the air duct. Position the left kick pad to the side panel and secure with two retaining screws.

8. Raise the car on a hoist. Engage the cable housing to the frame bracket with a U-clip (Fig. 1, Part 2-1). Install the spring seat, cable spring and washer on the rear end of the cable. Assemble the cable to the equalizer lever and install the half-moon type adjusting nut on the end of the cable.

9. Adjust the parking brake linkage as outlined in Part 2-1, Section 2, and then check the operation of the parking brake.

PARKING BRAKE EQUALIZER TO REAR WHEEL CABLE

1. Raise the car and remove the hub cap. Remove the wheel and tire

assembly from the drum.

2. Remove the three Tinnerman nuts that retain the brake drum, then remove the drum.

3. Loosen the adjusting nut on the equalizer rod and disengage the ball end of the cable from the equalizer (Fig. 1, Part 2-1).

4. Remove the U-clip that retains the cable housing to the frame bracket. Disengage the housing from the bracket and slip off the retainer hook (Fig. 15).

5. Working on the wheel side of the carrier plate (Fig. 1), compress the prongs on the cable retainer so that they can pass through the hole in the carrier plate. Draw the cable retainer out of the hole.

6. With the spring tension off the parking brake lever, lift the cable out of the slot in the lever and remove through the carrier plate hole.

INSTALLATION

1. Pull enough of the cable through the housing so that the end of the cable may be inserted through the carrier plate access hole from the inner side and engaged with the slot in the parking brake lever.

2. Pulling the excess slack from the cable, insert the cable housing into the carrier plate access hole so that the retainer prongs expand.

3. Thread the front end of the cable through the frame bracket, and engage the cable housing to the bracket. Install the U-clip and retainer hook (Fig. 15).

4. While holding the adjustable cable stop against the cable housing end, pull the cable through the housing until there is a distance of five inches between the two stops as shown in Fig. 15. Crimp the adjustable stop against the cable to hold this dimension.

5. Insert the ball end of the cable into the equalizer and tighten the adjusting nut slightly.

6. Install the rear drum. Tighten the three Tinnerman nuts that retain the drum, and install the wheel and hub cap.

7. Adjust the parking brake linkage as outlined in Part 2-1, Section 2.

MAJOR REPAIR OPERATIONS

BUY IT NOW!

Click Here To Order



A drum that is excessively scored or shows a total indicator runout of over 0.007 inch should be turned down. Remove only enough stock to

eliminate the scores and true up the drum. The refinished diameter must not exceed 0.060 inch oversize (11.150 inches).

If the drum diameter is less than 0.030 inch oversize (11.120 inches) after refinishing, standard lining may be installed. If the drum diameter is 11.120-11.150 inches, oversize linings must be installed.

After a drum is turned down, wipe the refinished surface with a cloth soaked in clean denatured alcohol. If one drum is turned down, the opposite drum on the same axle should also be cut down to the same size.

BRAKE SHOE RELINING

Brake linings that are worn to within $\frac{1}{32}$ inch of the rivet or have been saturated with grease or oil should be replaced. Failure to replace worn linings will result in a scored drum. **When it is necessary to replace linings, they must also be replaced on the wheel on the opposite side of the car.**

Inspect brake shoes for distortion, cracks, or looseness. If this condition exists, the shoe should be discarded. **Do not repair a defective brake shoe.**

1. Wash the brake shoes thoroughly in a clean solvent. Remove all burrs or rough spots from the shoes.

2. Check the inside diameter of the brake drum. If the diameter is less than 11.120 inches, standard linings may be installed. If the diameter is 11.120-11.150 inches, oversize lining should be installed.

3. Position the new lining on the shoe. Starting in the center, insert and secure the rivets, working alternately towards each end. Install all parts supplied in the kit. **Ford replacement linings are ground and no further grinding is required.**

4. Check the clearance between the shoe and lining. The lining must seat tightly against the shoe with not more than 0.005-inch clearance between any two rivets.

MASTER CYLINDER

DISASSEMBLY

1. Clean the outside of the cylinder, and remove the filler cap and gasket. Pour out any brake fluid that may remain in the cylinder or reservoir.

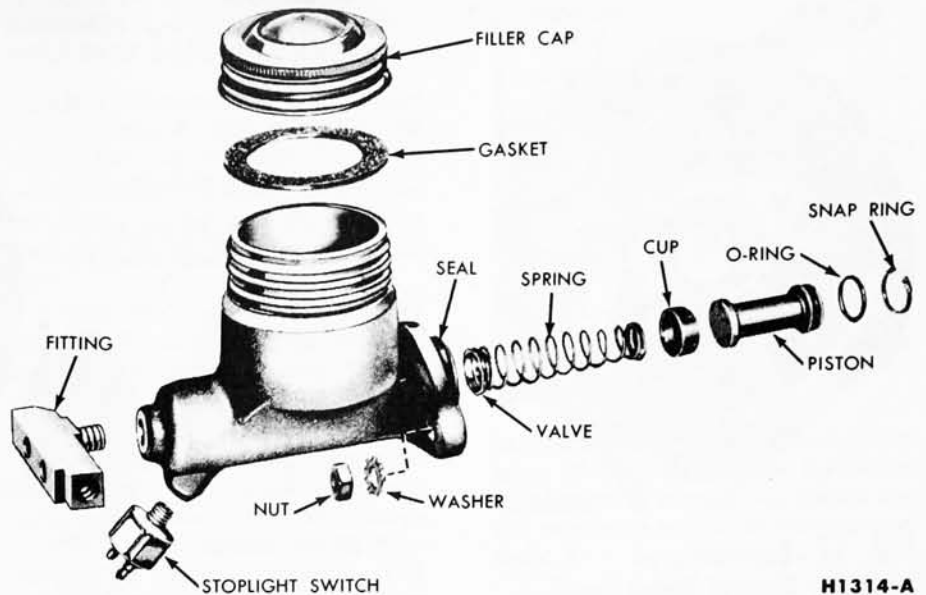

H1314-A

FIG. 16—Brake Master Cylinder Disassembled

4. Remove the piston assembly, cup, and the spring and check valve assembly from the cylinder bore. Remove the "O"-ring from the piston.

CLEANING, INSPECTION, AND REPAIR

1. Clean all master cylinder parts in clean denatured alcohol, and inspect the parts for wear or damage, replacing them as required. **When using a master cylinder repair kit, install all of the parts supplied.**

2. Check the ports and vents in the master cylinder to make sure that all are open and free of foreign matter.

3. Check the ports in the piston to make sure that they are open and free of foreign material.

4. Inspect the cylinder walls for scores or rust, and recondition them if necessary. **Hone the cylinder walls no more than necessary (0.003 inch maximum). Oversize pistons and cups are not available for excessively honed cylinders.**

5. Remove any burrs or loose metal that may have resulted from the honing operation, and clean the cylinder with denatured alcohol.

ASSEMBLY

1. Dip all parts except the master cylinder body in clean FoMoCo heavy-duty brake fluid.

2. Install the brake line fitting and the stop light switch on the cylinder and tighten them securely.

3. Install the "O"-ring on the piston. Install the spring and check

valve assembly, cup, and piston in the cylinder bore (Fig. 16).

4. Install the snap ring in the rear end of the bore.

DISASSEMBLY OF BOOSTER REMOVAL OF EXTERNAL PARTS

1. Remove the two attaching nuts and lock washers, and separate the master cylinder from the booster body.

2. Remove the filter cover and hub and the air filter from the booster body (Fig. 5, Part 2-1).

3. Remove the vacuum manifold and check valve assembly and the rubber grommet from the booster body (Fig. 5, Part 2-1).

4. Disconnect the valve operating rod from the lever assembly by removing the retainer clip and connecting pin (Fig. 5, Part 2-1).

5. Disconnect the lever assembly from the end plate brackets by removing the retainer clip and pivot pin.

6. Remove the retaining nuts, and disassemble the brackets from the end plate.

7. Remove the rubber boot from the valve operating rod.

SEPARATION OF MAJOR COMPONENTS

1. Remove the large C-ring that retains the rear seal adapter assembly to the booster end plate (Fig. 5, Part 2-1).

2. Scribe a line across the booster body and end plate to facilitate prop-



BUY IT NOW!

Click Here To Order



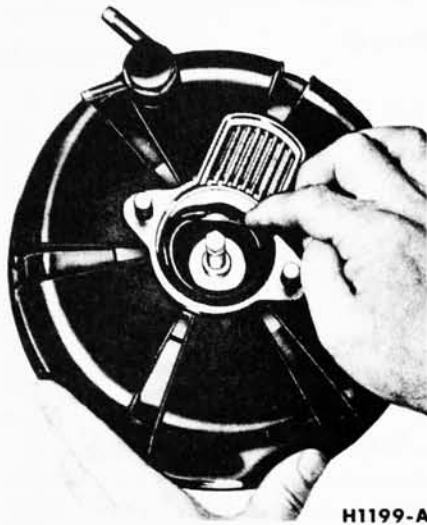

H1199-A

FIG. 17—Separation of Bellows, Control Valve, and Diaphragm Assembly from Booster Body

er alignment at assembly. Remove the booster body-to-end plate retaining screws, tap the outside of the end plate with a fibre hammer, and separate the end plate from the booster body, leaving the rear seal and adapter assembly on the control valve hub.

3. Push the bellows assembly into the vacuum chamber (Fig. 17), and separate the bellows, control valve, and diaphragm assembly from the booster body.

4. Remove the outer "O"-ring from the rear seal adapter assembly (Fig. 5, Part 2-1).

DISASSEMBLY OF BELLOWS, PUSH ROD AND VALVE ASSEMBLY FROM DIAPHRAGM

1. Be careful not to break valve plunger by applying pressure to push rod. Remove the large bellows re-

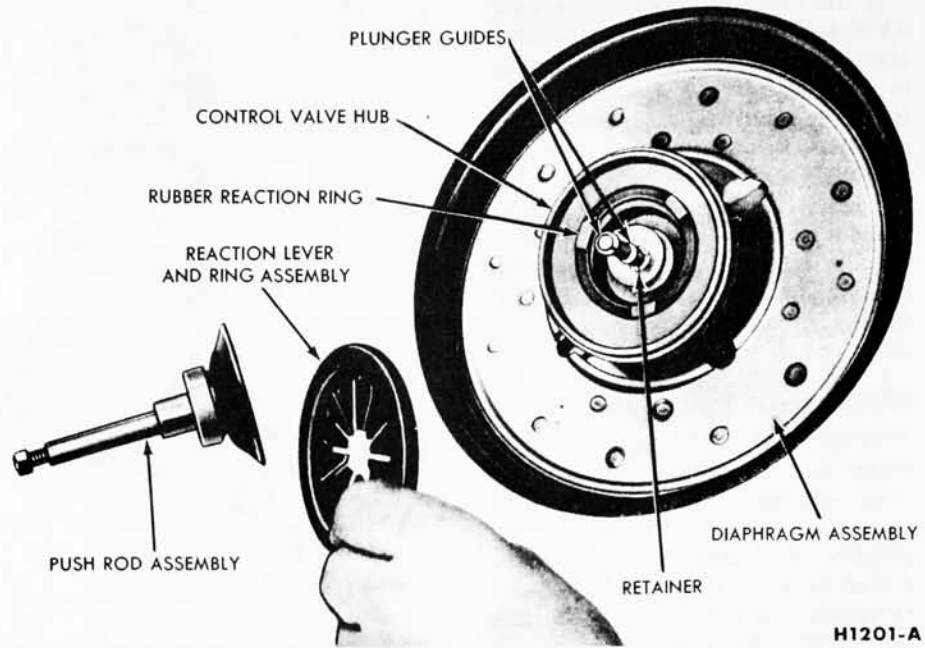

H1201-A

FIG. 19—Assembly of Reaction Components and Push Rod to Valve Hub

taining ring, bellows, bellows retainer and support ring from the diaphragm and valve assembly (Fig. 18).

2. Remove the retainer and support ring from the bellows (Fig. 5, Part 2-1).

3. Remove the push rod assembly, the reaction lever and ring from the control valve hub (Fig. 19).

4. Remove the retainer, the cushion ring and the reaction cone from the push rod assembly, and disas-

semble the reaction levers from the rings (Fig. 19). Also see Fig. 5, Part 2-1.

5. Remove the two plastic plunger guides from the control valve plunger, then remove the retainer that holds the reaction load ring, return spring, and atmospheric valve to the control valve hub (Fig. 19).

6. Slide the reaction load ring, the return spring and the atmospheric valve from the control valve hub (Figs. 19 and 20).

7. Separate the control valve hub

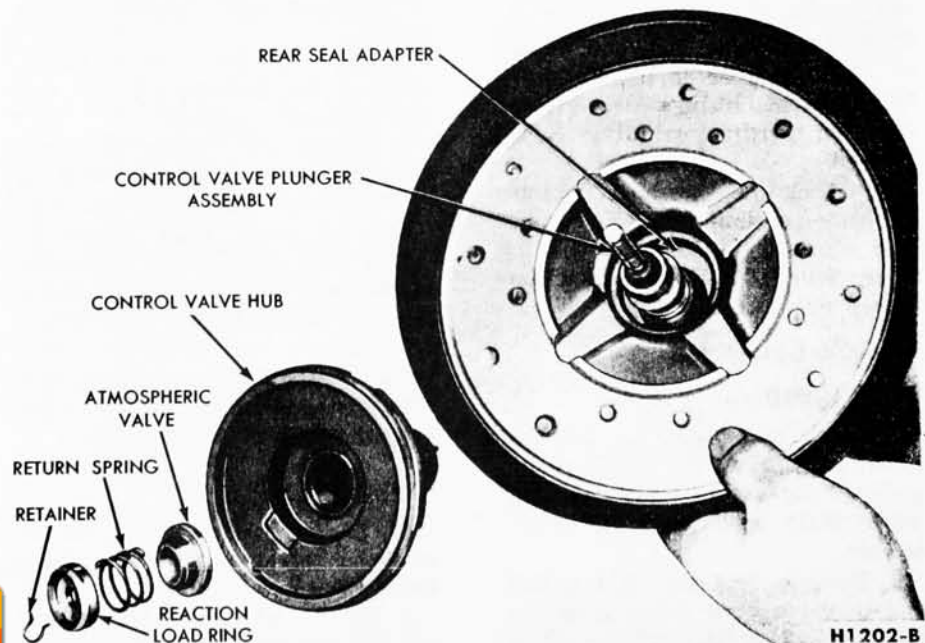

H1202-B

FIG. 20—Disassembly of Control Valve Components from Diaphragm



BUY IT NOW!

Click Here To Order



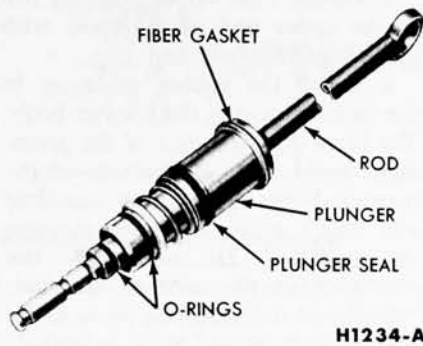

FIG. 21—Valve Operating Rod and Plunger Assembly

and the control valve plunger assembly from the diaphragm by sliding the valve plunger and rear seal adapter from the rear of the valve hub (Fig. 20). Remove the hub outer "O"-ring from the front side of the diaphragm.

DISASSEMBLY OF CONTROL VALVE PLUNGER

1. Remove the hub rear seal adapter from the valve plunger assembly, and remove the seal from the adapter.

2. Remove the "O"-rings, the seal, and the fibre gasket from the valve plunger (Fig. 21).

3. **Do not remove the valve operating rod from the control valve plunger unless the plunger assembly or the rod is to be replaced.** To remove, hold the rod firmly and force the plunger off the rod, breaking the plastic retainer. Remove all the broken pieces of the plastic retainer from the groove in the plunger, if the plunger is to be used again with a replacement rod.

ASSEMBLY OF BOOSTER

ASSEMBLY OF CONTROL VALVE PLUNGER

1. If the valve operating rod was removed from the plunger, assemble a new plastic retainer to the end of the rod (Fig. 5, Part 2-1). Insert the

ASSEMBLY OF VALVE ASSEMBLY, PUSH ROD, AND BELLOWS TO DIAPHRAGM

1. Insert the control valve plunger into the control valve hub from the rear of the hub (Fig. 22).

2. Assemble the atmospheric valve, the return spring and the reaction load ring to the valve plunger and hub.

3. Push the control valve plunger assembly forward and the reaction load ring backward against the return spring in order to install the retainer in the groove of the plunger.

4. Install the "O"-ring in the groove on the outer circumference of the valve hub. Assemble the valve plunger and hub assembly to the diaphragm so that the operating rod and the small-diameter end of the diaphragm and protrude from the rear side.

5. Install the two plastic plunger guides in their grooves on the valve plunger assembly (Fig. 19).

6. Install the rubber reaction ring in the valve hub so that the ring locating knob indexes in the notch in the hub (Fig. 22), with the ring tips toward the front (Fig. 19).

7. Assemble the reaction lever and ring assembly, then install the assembly in the valve hub (Fig. 19).

8. Assemble the reaction cone and cushion ring to the push rod, and secure to the rod with the retainer (Fig. 5, Part 2-1). Install the push rod assembly to the valve hub so that the valve plunger indexes in the push rod (Fig. 19).

9. Assemble the bellows, retainer, and support ring (Fig. 5, Part 2-1). The support ring is positioned on the middle fold of the bellows.

10. Position the bellows assembly and secure it to the diaphragm by installing the retaining ring (Fig. 18). **Make sure that the retaining ring is fully seated.**

ASSEMBLY OF MAJOR COMPONENTS

1. Exercise extreme care during assembly not to break valve plunger by applying pressure to push rod. With a screw driver, slightly move the booster body retaining screw tapping channel in order to provide a new surface for the self-tapping attaching screws (Fig. 5, Part 2-1).

2. Install the diaphragm, the control valve components, and the

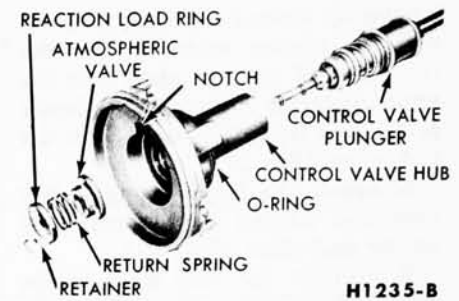

FIG. 22—Assembly of Control Valve Components to Valve Hub

bellows as an assembly to the booster body. **Make sure that the lip of the diaphragm is evenly positioned on the retaining radius of the booster body.**

3. Install the "O"-ring in the front side of the end plate.

4. Install the valve hub rear seal in the adapter assembly with the

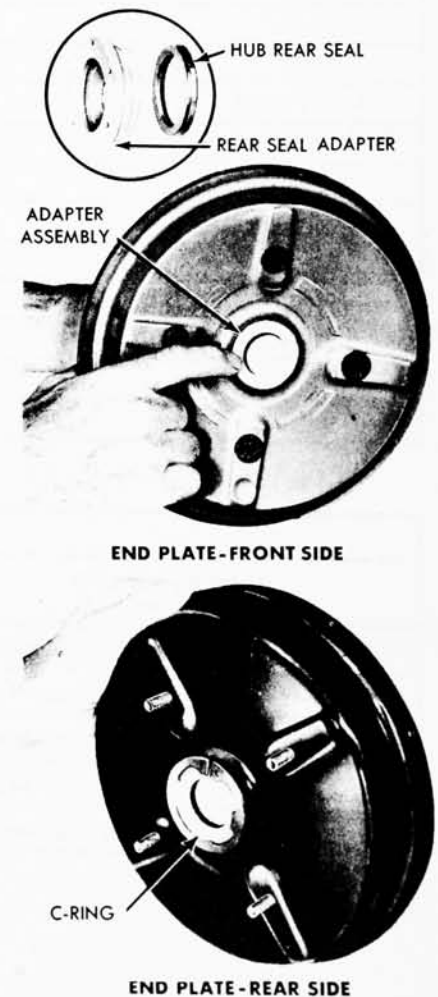

FIG. 23—Installation of Hub Rear Seal and Adapter Assembly

100% SATISFACTION GUARANTEED

BUY IT NOW!

Click Here To Order

PayPal American Express Discover Novus MasterCard VISA

sealing lip toward the rear, then install the adapter assembly into the front side of the end plate with the small diameter end of the adapter protruding from the rear side of the end plate (Fig. 23).

5. Install the large C-ring to the rear seal adapter at the rear side of the end plate (Fig. 23).

6. Position the end plate to the booster body. Align the scribe lines, compress the two assemblies together with a clamp, then install the attaching screws.

7. Pull the front lip of the bellows through the booster body, and position it around the outer groove of

the booster body (Fig. 17).

8. Adjust the push rod as outlined in Part 2-1, Section 2.

INSTALLATION OF EXTERNAL PARTS

1. Install the rubber boot to the valve operating rod (Fig. 5, Part 2-1).

2. Position the mounting brackets to the end plate, and install the retaining nuts.

3. Connect the lever assembly to the lower end of the mounting brackets with the pivot pin. Install the retainer clip.

4. Connect the valve operating rod to the upper end of the lever with the connecting pin and clip.

5. Install the rubber grommet in the vacuum port in the booster body. The large diameter side of the grommet should be to the outside of the booster. Force the vacuum manifold and check valve assembly through the grommet. **Do not push the grommet into the vacuum chamber.**

6. Install the following parts to the booster body in the order indicated: first the air filter, then the filter cover and hub, and finally the brake master cylinder. Torque the master cylinder mounting nuts to specifications.



PART 2-3 SPECIFICATIONS

DIMENSIONS—IN INCHES

Axle	Drum Inside Diameter	Drum Maximum Boring Limit	Lining Length		Lining Width		Wheel Cylinder Bore Diameter	Master Cylinder Bore Diameter
			Primary	Secondary	Primary	Secondary		
Front	11.090	11.150	9.39	12.21	3.00	3.00	1 $\frac{3}{32}$	$\frac{7}{8}$
Rear			9.39	12.21	2.50	2.50	1 $\frac{1}{16}$	$\frac{7}{8}$

TORQUE LIMITS

Description	Ft-Lbs
Brake Shoe Adjusting Screw Lubricant—Stanolube—HD Moly Grease—Grade 2	57
Brake Carrier Plate to Spindle—Upper Bolts & Nuts	25-35
Brake Carrier Plate to Spindle—Lower Bolts & Nuts	70-95
Brake Cylinder to Front Carrier Plate	10-20
Front Wheel to Hub and Drum	75-110
Front Brake Hose Bracket to Chassis Bolt	10-15
Rear Brake Drum to Rear Axle Shaft Flange	Hand Push Fit
Rear Wheel to Axle Shaft to Drum	75-110
Rear Brake Carrier Plate and Bearing Retainer to Axle Housing	50-70
Master Cylinder to Booster	12-18
Master Cylinder Tube Fitting	6-12
Stop Light Switch to Master Cylinder	6-12
Brake Booster to Dash Panel and Pedal Support Bracket	15-25
Parking Brake Control to Mounting Bracket	15-19
Brake Fluid—M-3833-D	—

BRAKE CHECKS AND ADJUSTMENTS

Type of Check or Adjustment	Specification
Brake Shoe Repair	Drum Diameter 11.120-11.150 inch
	Brake Lining Required Oversize
	Brake Lining Clearance (Midway between Rivets) Maximum 0.005 inch
	Lining Wear Limit (From Top of Rivets) Maximum $\frac{1}{32}$ inch
Master Cylinder	Hydraulic Master Cylinder Bore, Honed Diameter. Maximum 0.878 inch
Power Unit	Push Rod Adjustment 0.995-1.005 inch
Drum Out-of-Round	Refinish if Total Indicator Runout Exceeds 0.007 inch



SUSPENSION, STEERING, WHEELS AND TIRES

GROUP 3

PART 3-1	PAGE	PART 3-4	PAGE
SUSPENSION, STEERING, WHEELS AND TIRES—GENERAL SERVICE	3-1	WHEELS AND TIRES	3-32
PART 3-2		PART 3-5	
SUSPENSION	3-7	SPECIFICATIONS	3-36
PART 3-3			
STEERING	3-16		

PART 3-1 SUSPENSION, STEERING, WHEELS AND TIRES—GENERAL SERVICE

Section	Page	Section	Page
1 Diagnosis and Testing	3-1	3 Cleaning and Inspection	3-5
2 Common Adjustments and Repairs	3-4		

1 DIAGNOSIS AND TESTING

Table 2 lists various suspension, steering, and wheel and tire trouble symptoms and their possible causes. The possible causes are listed in the table in the order in which they should be checked. For example, refer to the fourth trouble symptom in Table 1, "Hard Turning When Stationary". When checking the possible causes, check item 1 (tire pressure) and item 2 (tire size) before proceeding with items 12, 17, and 21 as indicated.

Refer to Table 1 for Movable Steering Column Trouble Symptoms and Possible Causes.

PRELIMINARY CHECKS

The following preliminary checks

should always be made before performing any trouble shooting operations. Also, see Table 2.

CHECK PUMP BELT

If the pump belt is broken, glazed, or worn, replace it with a new belt. **Use only the specified type of belt.**

1. Check the belt tension, using tool No. T62L-8620-A. See Part 3-5 for specified tension on new and on used belts. A "used belt" is one that has run 15 minutes or longer.

2. If necessary, loosen the power steering pump bracket adjusting bolt and the pivot bolt.

3. Increase or decrease the tension as required by adjusting the pump

position.

4. Torque the adjusting bolt and the pivot bolt to specification, and check the belt tension again.

CHECK FLUID LEVEL

Run the engine until the fluid is at normal operating temperature. Then turn the steering wheel all the way to the left and right several times, and shut off the engine.

Check the fluid level in the reservoir. If the level is low, add enough automatic transmission fluid to raise the level to a point one inch from the top, or to the F mark on the dip stick. **Do not overfill the reservoir.**

TABLE 1—Movable Steering Column Trouble Symptoms and Possible Causes

BINDING, ROUGH, OR RASPING COLUMN MOVEMENT	Track to column bracket misalignment. Locking plate out of adjustment rubs pawl.	Shroud interference with instrument panel.
	Slide tension out of adjustment. Track to column bracket misalignment.	Locking plate out of adjustment—rubs pawl.



BUY IT NOW!

Click Here To Order



CONTINUED ON NEXT PAGE

TABLE 1—Movable Steering Column Trouble Symptoms and Possible Causes (continued)

POSSIBLE SHIFT INTO REVERSE WITH COLUMN AT EXTREME RIGHT	Locking plate out of adjustment.	
POOR SHIFTING INTO OR OUT OF PARK	Left stop out of adjustment. Lock pawl arm binding in pivot	bushing.
LATERAL LOOSENESS IN COLUMN WHEN LOCKED	Locking pawl arm loose in pivot bushing.	Pivot bracket loose at steering gear.
VERTICAL LOOSENESS IN COLUMN WHEN LOCKED	Loose track or braces. Pivot bracket loose at steering	gear. Slide tension out of adjustment.
RIGHT SHROUD HITS AIR CONDITIONING UNIT	Right stop bolt (on track) out of adjustment.	

CHECK FOR FLUID LEAKS

With the engine idling, turn the steering wheel from stop to stop several times. Check all possible leakage points. Tighten all loose fittings, and replace any damaged lines or defective seats.

CHECK TURNING EFFORT

With the front wheels properly aligned and tire pressures correct, check the effort required to turn the steering wheel.

1. With the car on dry concrete, set the parking brakes.

2. With the engine warmed up and running at idle speed, turn the steering wheel to the left and right several times to warm the fluid.

3. Attach a pull scale to the rim of the steering wheel. Measure the pull required to turn the wheel one complete revolution in each direction. The effort required to rotate the steering wheel should not exceed 3.5 pounds.

FLUID PRESSURE TEST

A fluid pressure test will show whether the pump or some other unit in the power steering system is causing trouble in the system.

1. Disconnect the pressure line from the gear (Fig. 1) and install the pressure testing tool between the line and the gear. **Be sure that the pressure gauge is between the pump and the shut-off valve on the tool.**

the shut-off valve on the

for the fluid to warm up before starting the pressure tests.

3. Turn the front wheels all the way to the right and then to the left, noting the fluid pressure reading on the gauge when each wheel is against its stop. Normal fluid pressure at both positions is 700-850 psi maximum. **Do not hold a wheel against its stop because the fluid may overheat.**

4. If the fluid pressure, with a wheel against its stop, is less than 700 psi, turn the wheel off the stop. Slowly close the testing tool shut-off valve, and watch the gauge for an increase in pressure. **Do not leave the valve closed for more than 15 seconds.**

5. If the fluid pressure, with the shut-off valve fully closed, still shows less than 700 psi, the pump is causing the trouble. If the pressure increases to 700-850 psi, the trouble is in the power steering gear.

6. After the fluid pressure test is complete, shut off the engine and

remove the pressure testing tool. Make the necessary repairs or replacements to eliminate the trouble in the system.

FRONT WHEEL ALIGNMENT CHECKS

Do not attempt to check and adjust front wheel alignment without first making a preliminary inspection of the front-end parts.

Check all the factors of front wheel alignment except toe-out on turns before making any adjustments. Toe-out on turns should be checked only after caster, camber and toe-in have been adjusted to specifications.

EQUIPMENT INSTALLATION

Equipment used for front wheel alignment inspection must be accurate. If portable equipment is being used, perform all inspection operations on a level floor.

1. Drive the car in a straight line far enough to establish the straight-ahead position of the front wheels, and then mark the steering wheel hub and the steering column collar (Fig. 2). **Do not adjust the steering wheel spoke position at this time.** If the front wheels are turned at any time during the inspection, align the marks to bring the wheels back to the straight-ahead position.

2. Install the wheel alignment equipment on the car. Whichever type of equipment is used, follow the installation and inspection instructions provided by the equipment manufacturer.

CASTER

Check the caster angle at each front wheel. Caster is the forward or rearward tilt at the top of the wheel spindle. If the spindle tilts to the

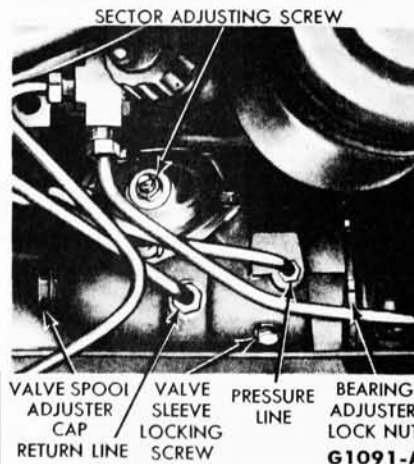

FIG. 1—Adjustments

100% SATISFACTION GUARANTEED

BUY IT NOW!

Click Here To Order

PayPal, American Express, Discover, MasterCard, VISA

TABLE 2—Trouble Symptoms and Possible Causes

POSSIBLE CAUSES OF TROUBLE	TROUBLE SYMPTOMS														
	Jerky Steering	Loose Steering	Hard Steering and/or Loss of Power Assist	Hard Turning When Stationary	Steering and Suspension Noises	Shimmy or Wheel Tramp	Pull to One Side	Side-to-Side Wander	Body Sway or Roll	Tire Squeal on Turns	Binding or Poor Recovery	Abnormal or Irregular Tire Wear	Sag at One Wheel	Hard or Rough Ride	Rear Suspension Misalignment (Dog-Tracking)
1. Incorrect Tire Pressure			X	X	X	X	X	X	X	X		X	X	X	
2. Tire Sizes Not Uniform			X	X		X	X	X				X	X		
3. Overloaded or Unevenly Loaded Vehicle								X				X	X	X	
4. Power Steering Fluid Level Low-Leak	X		X	X	X										
5. Sagging or Broken Spring					X	X	X	X	X			X	X	X	
6. Glazed, Loose or Broken Power Steering Pump Belt	X		X	X	X										
7. Rear Spring Tie Bolt Off Center							X					X			X
8. Broken Rear Spring Tie Bolts					X	X	X	X	X			X			X
9. Rear Spring Front Hanger Mislocated							X					X			X
10. Bent Spindle Arm							X	X		X		X			
11. Bent Spindle							X	X		X		X			
12. Lack of Lubrication			X	X	X						X			X	
13. Air in Power Steering System	X		X		X	X									
14. Obstruction in Power Steering Lines			X	X	X										
15. Loose or Weak Shock Absorber					X	X			X			X		X	
16. Loose or Worn Suspension Arm Bushings					X	X						X		X	
17. Binding Front Suspension Ball Joints or Steering Linkage	X		X	X	X						X			X	
18. Loose, Worn, or Damaged Steering Linkage or Connections	X	X			X	X		X		X		X			
19. Loose Steering Gear Mountings	X	X			X	X		X	X						
20. Insufficient Steering Pump Pressure			X	X							X				
21. Incorrect Steering Gear Adjustment	X	X	X	X	X	X		X	X		X	X			
22. Incorrect Brake Adjustment	X				X		X					X			
23. Incorrect Front Wheel Bearing Adjustment	X	X			X	X	X	X				X			
24. Wheel Out of Balance	X				X	X						X		X	
25. Incorrect Front Wheel Alignment			X		X	X	X	X		X	X	X			
26. Out-of-Round Wheel or Brake Drum						X						X		X	
27. Frame or Underbody Out of Alignment							X					X			X
Front Drive Axle Housings					X		X					X			X
Steering Gear Parts					X										
Steering Gear Shim of Adjustment			X	X								X			
Steering Gear Shim			X	X								X			

100% SATISFACTION GUARANTEED

BUY IT NOW!

Click Here To Order

ALIGNMENT MARKS

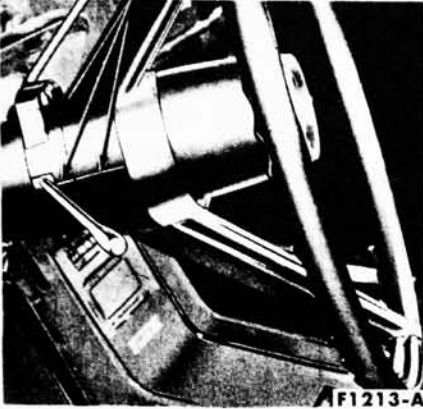

FIG. 2—Typical Straight-Ahead Position Marks

rear, caster is positive. If the spindle tilts to the front, caster is negative. The correct caster angle, or tilt, is

$-3/4^\circ$ to $-2 1/4^\circ$. The maximum difference between both front wheel caster angles should not exceed $1/2^\circ$. However, a difference of not more than $1/4^\circ$ is preferred.

CAMBER

Check the camber angle at each front wheel. The camber angle is the amount the front wheels are tilted at the top. If a wheel tilts outward, camber is positive. If a wheel tilts inward, camber is negative. The correct camber angle, or outward tilt, is 0° to $+3/4^\circ$. The maximum difference between both front wheel camber angles should not exceed $1/2^\circ$. However, a difference of not more than $1/4^\circ$ is preferred.

TOE-IN

Check the toe-in with the front

wheels in the straight-ahead position. Run the engine so that the power steering control valve will be in the center (neutral) position. Measure the distance between the extreme front and also between the extreme rear of both front wheels. The difference between these two distances is the toe-in.

Correct toe-in, or inward pointing of both front wheels at the front, is $1/8$ - $1/4$ -inch.

After caster, camber, and toe-in have been adjusted to specifications, check the turning angle. The turning angle of an outside wheel should be $18^\circ 53'$ when the inside wheel is turned 20° .

If this angle is not correct, the spindle arm is probably bent and should be replaced.

2 COMMON ADJUSTMENTS AND REPAIRS

WHEEL ALIGNMENT ADJUSTMENTS

After front wheel alignment factors have been checked, make the necessary adjustments. Do not attempt to adjust front wheel alignment by bending the suspension or steering parts.

CAMBER

Adjust the camber by removing or installing shims between the pivot bracket of the front suspension lower arm and the mounting bracket on the underbody in the engine compartment (Fig. 3).

The removal of shims between the mounting and pivot brackets will move the lower ball joints inward. The installation of shims between the mounting and pivot brackets will move the lower ball joint outward. Camber adjusting shims are available in several standard shim thicknesses. A $1/16$ -inch change of shim thickness will change the camber angle $1/3^\circ$. The total shim stack thickness should not exceed $1 1/16$ -inch.

CASTER

The caster adjustment is made by repositioning the strut on the lower arm as shown in Fig. 3. Adjust the rearward mounting by loosening the rearward

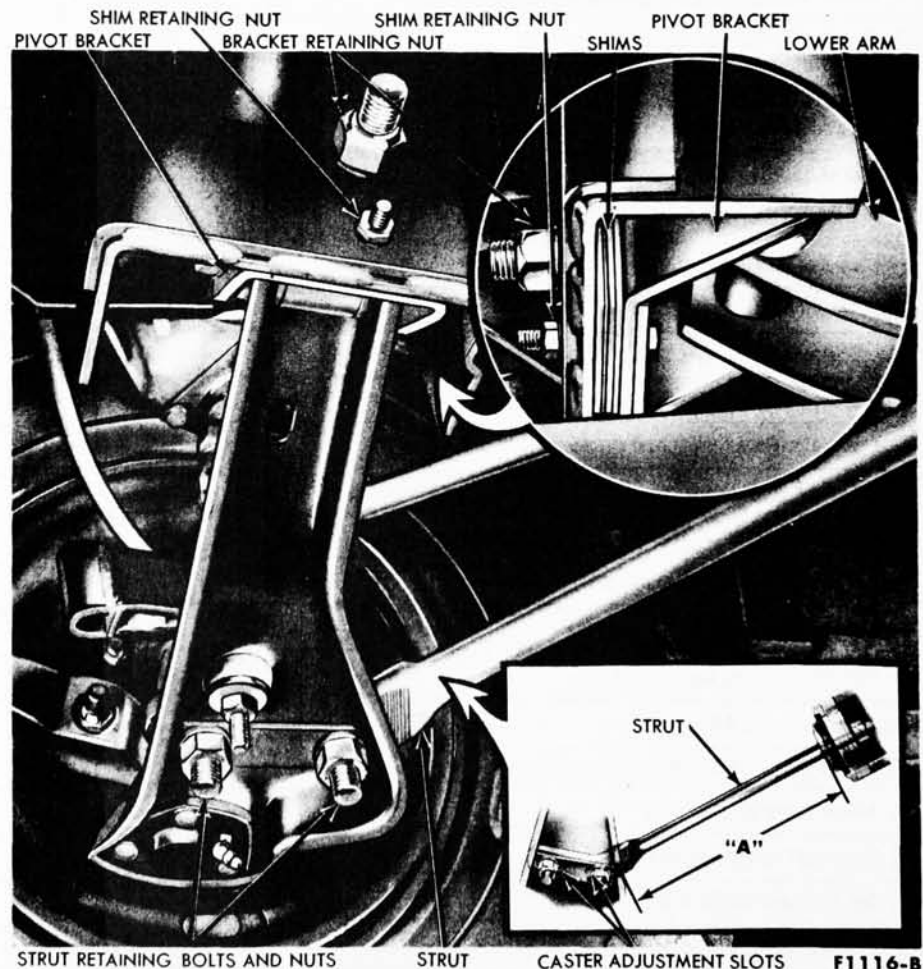

FIG. 3—Caster and Camber Adjustments

3, dimension "A") to decrease the caster angle. Decrease the distance between the strut forward mount and the rearward mount on the side of the lower arm (Fig. 3,

dimension "A") to increase the caster angle. Tighten the rearward nuts that retain the strut to the lower arm. Check the caster, camber,

100% SATISFACTION GUARANTEED

BUY IT NOW!

Click Here To Order

and the side of the lower arm.

PayPal, American Express, Discover, MasterCard, VISA

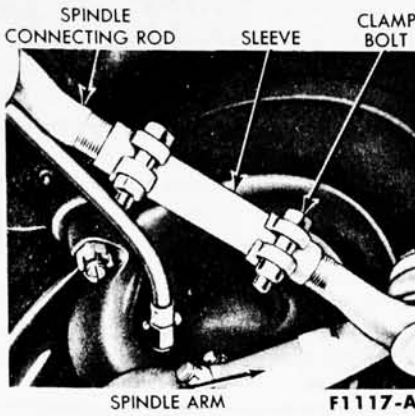

FIG. 4—Spindle Connecting Rod Sleeve

and toe-in alignment for the correct settings listed in the specifications.

TOE-IN AND STEERING WHEEL ALIGNMENT ADJUSTMENTS

Check the steering wheel spoke position when the front wheels are in the straight-ahead position. If the spokes are not in their normal position, they can be properly adjusted while toe-in is being adjusted.

1. Loosen the two clamp bolts on each spindle connecting rod sleeve (Fig. 4).

2. Adjust toe-in. If the steering wheel spokes are in their normal position, lengthen or shorten both rods equally to obtain correct toe-in (Fig. 5). If the steering wheel spokes are not in their normal position, make the necessary rod adjustments

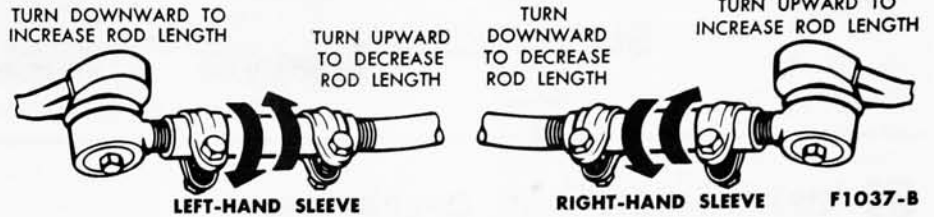

FIG. 5—Spindle Connecting Rod Adjustments

to obtain correct toe-in and steering wheel spoke alignment (Fig. 6).

3. Recheck toe-in and steering wheel spoke alignment. If toe-in is correct and the steering wheel spokes are still not in their normal position, turn both connecting rod sleeves up-

ward or downward the same number of turns to move the steering wheel spokes (Fig. 6).

4. When toe-in and steering wheel spoke alignment are both correct, torque the clamp bolts on both connecting rod sleeves to specifications.

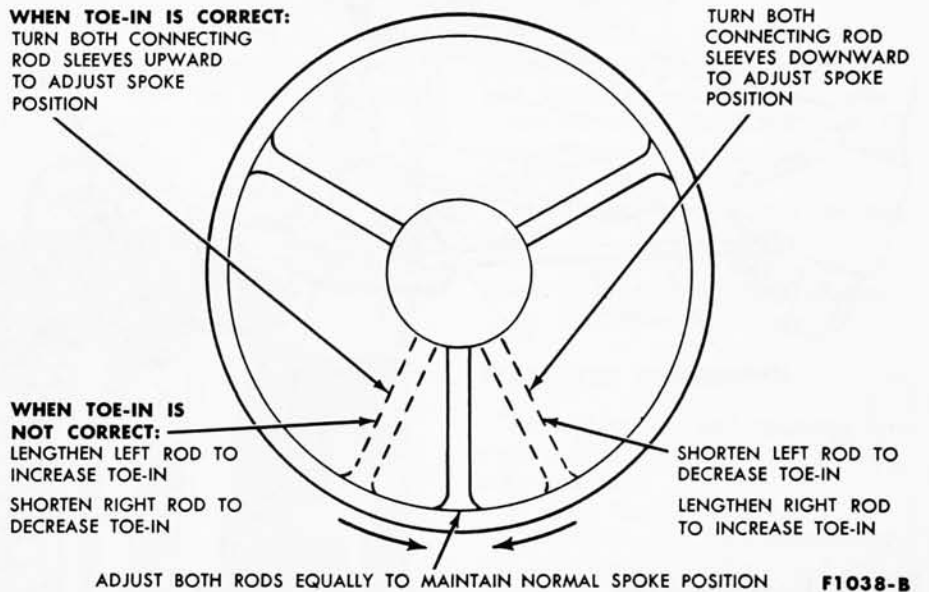

FIG. 6—Toe-in and Steering Wheel Spoke

3 CLEANING AND INSPECTION

FRONT END GENERAL INSPECTION

Do not check and adjust front wheel alignment without first making the following inspection for front-end maladjustment, damage, or wear.

1. Check for specified air pressures in all four tires.

2. Raise the front of the car off the floor. Shake each front wheel grasping the upper and lower sur-

ings and all steering linkage connections for looseness. Torque all mountings to specifications. If any of the linkage is worn or bent, replace the parts as outlined in Part 3-3.

4. Check the front wheel bearings. If any in-and-out free play is noticed, adjust the bearings to specification. Replace worn or damaged bearings as outlined in Part 3-4.

5. Spin each front wheel with a wheel spinner, and check and balance each wheel as required.

6. Check the action of the shock absorbers. If the shock absorbers are not in good condition, the car may not settle in a normal, level position, and front wheel alignment may be affected.

WHEEL INSPECTION

Wheel hub nuts should be inspected and tightened to specification at predelivery. Loose wheel hub nuts may cause shimmy and vibration. Elongated stud holes in the wheels may also result from loose hub nuts.

Keep the wheels and hubs clean. Stones wedged between the wheel and drum and lumps of mud or grease can unbalance a wheel and tire.

Check for damage that would affect the runout of the wheels. Wobble or shimmy caused by a damaged wheel will eventually damage the wheel bearings. Inspect the wheel rims for dents that could permit air to leak from the tires.

100% SATISFACTION GUARANTEED

BUY IT NOW!

Click Here To Order

WORLDWIDE DELIVERY AVAILABLE. CALL 1-800-333-3333

PayPal, American Express, Discover, MasterCard, VISA

PART 3-2 SUSPENSION

Section	Page
1 Description and Operation	3-6
2 In-Car Adjustment and Repairs	3-7
3 Removal and Installation	3-8
4 Major Repair Operations	3-12

1 DESCRIPTION AND OPERATION

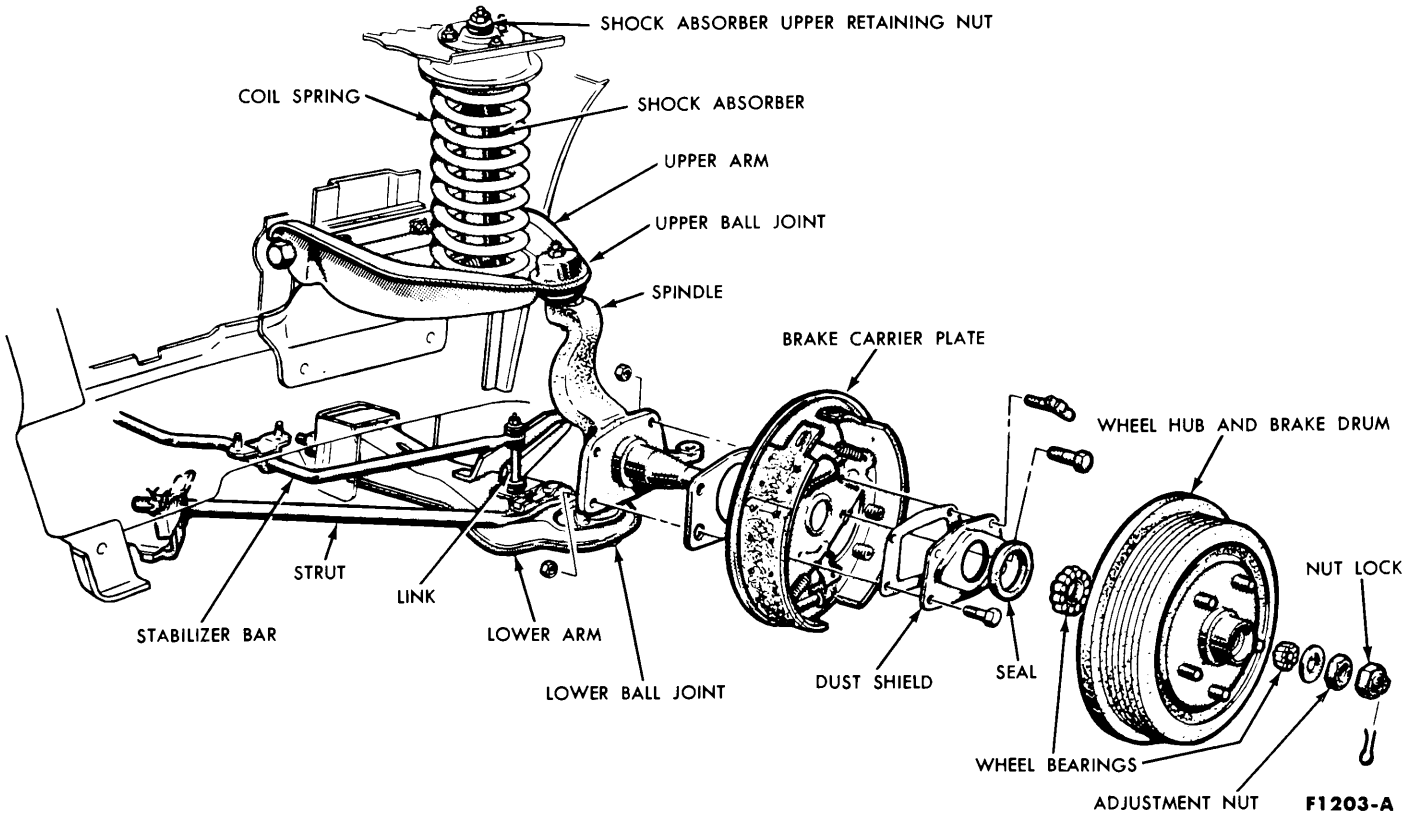

FIG. 1—Front Suspension

FRONT SUSPENSION

Each front wheel rotates on a spindle. The upper and lower ends of the spindle are attached to upper and lower ball joints which are mounted to an upper and lower arm respectively. The upper arm

pivots on a bushing and shaft assembly which is bolted to the underbody. The lower arm pivots on a bolt mounted in a bracket which is bolted to the underbody (Fig. 1). A coil spring seats between the upper arm and the top of the spring housing. A double-acting shock absorber

is bolted to the upper arm and the top of the spring housing.

The swiveling action of the ball joints allows the wheel and spindle assemblies to move up and down with changes in road surface. The swiveling ball joints also permit the spindles and wheels to be turned to

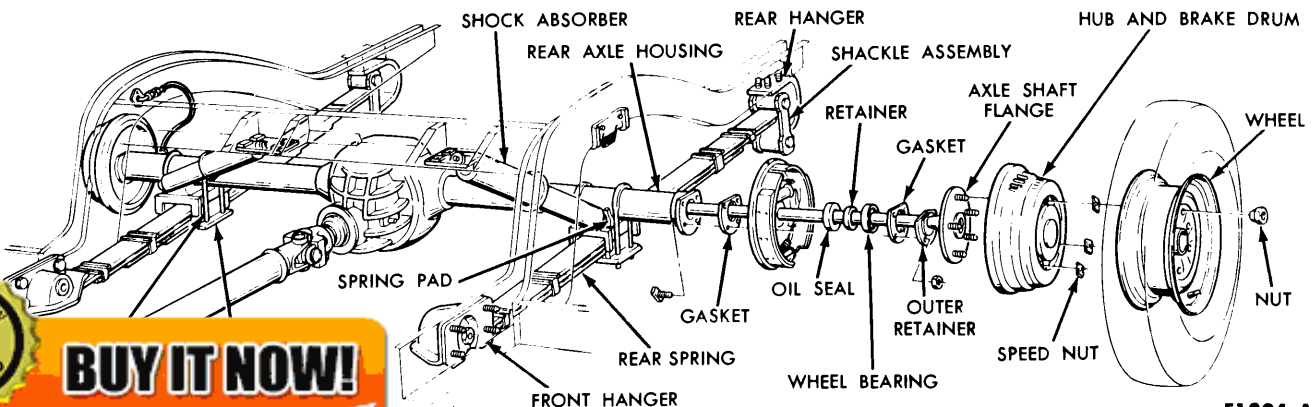

100% SATISFACTION GUARANTEED

BUY IT NOW!

Click Here To Order

PayPal, American Express, Discover, MasterCard, VISA

the left or right by the steering gear and linkage.

The pivoting action of the suspension arms provides **up and down** movement for the spindles and wheels as required by bumps or depressions in the road surface. The coil springs, shock absorbers, and stabilizer bar control the front suspension up and down movements.

The struts, which are connected between the suspension lower arms and the underbody, prevent the suspension arms from moving forward

and backward.

REAR SUSPENSION

Each rear wheel, hub and brake drum assembly is bolted to the rear axle shaft flange. The wheel and axle shaft assembly rotates in the rear axle housing. Two spring pads, integral with the axle housing, rest on two leaf spring assemblies. The axle housing is fastened to the center of the springs by spring clips (U-bolts), spring clip plates, and nuts (Fig. 2). Each spring as-

sembly is suspended from the underbody side rail by hanger and shackle assemblies at the front and rear. The upper end of each shock absorber is mounted to a bracket in the under body; the lower end is mounted to the spring pad at the axle housing.

The springs and shock absorbers provide for up and down movement of the rear axle and wheels as required by changes in the road surface. They also cushion road shocks.

2 IN-CAR ADJUSTMENT AND REPAIRS

UPPER BALL JOINT REPLACEMENT—ARM IN CAR

1. Raise the front of the car and position safety stands under the chassis.

2. Remove the wheel and tire assembly.

3. Loosen the upper stud (ball joint-to-arm) nut.

4. Remove the cotter pin and loosen the upper ball joint stud nut. Place a box wrench over the lower end of tool T57P-3006-A, and position the tool as shown in Fig. 3. **The tool should seat firmly against the ends of both studs, and not against the lower stud nut.** It may be necessary to remove the cotter pin from the lower ball joint stud if the cotter pin prevents the tool from seating on the lower stud.

5. Turn the wrench until both studs are under tension, then loosen the stud from the spindle by tapping the spindle near the upper stud with a hammer. **Do not loosen the stud with tool pressure alone.** Remove the ball joint stud nut.

6. Slide the ball joint stud out of the spindle upper bore. Remove the upper retaining nut, and drive the ball joint out of the suspension arm.

8. Position the replacement ball

joint in its recess in the upper arm. Install the retaining nut on the upper stud and draw the ball joint into place by tightening the nut.

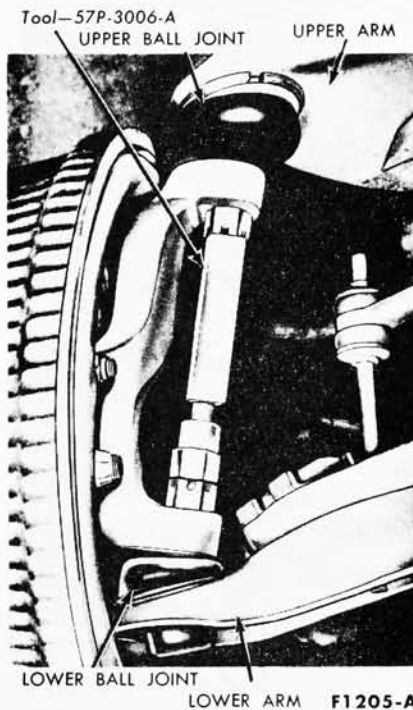

FIG. 3—Loosening Ball Joint Stud

9. Position the ball joint stud in the spindle bore, install the stud nut, and torque to specifications. Install a new cotter pin. Tighten the nut, if necessary, to align the cotter pin hole.

10. Install the wheel and tire assembly.

11. Remove the safety stands, lower the car, and check camber, caster and toe-in.

STABILIZER REPAIR

To replace the end bushings on each stabilizer link, use the following procedure.

1. Raise the car on a hoist.
2. Remove the link-to-stabilizer bar retaining nut, washers, and insulators, and disconnect the link from the bar (Fig. 1).
3. Remove the link-to-lower arm retaining nut, washers, and insulators, and remove the link from the arm.
4. Assemble the link and new washers and insulators to the lower arm, then install the link-to-lower arm retaining nut.
5. Connect the link to the bar with new washers and insulators and secure with the retaining nut.
6. Lower the car.

3 REMOVAL AND INSTALLATION

FRONT WHEEL SPINDLE

100% SATISFACTION GUARANTEED

BUY IT NOW!

Click Here To Order

PayPal American Express Cards Discover Novus MasterCard VISA

3. Remove the four retaining bolts and nuts, then remove the brake carrier plate from the spindle (Fig. 1). Wire the brake assembly to a convenient place on the chassis to avoid breaking the brake hose.

4. Remove the cotter pin and retaining nut, then disconnect the

spindle connecting rod end from the spindle arm with tool CJ89-1.

5. Remove the cotter pins and loosen the ball joint stud nuts.

6. Position a box wrench over the lower end of the tool T57P-3006-A and position the tool as shown in Fig. 3. **The tool should seat firmly**

against the ends of both studs, not against the stud nuts.

7. Turn the wrench until the tool places the studs under tension, then loosen the studs in the spindle by tapping the spindle near the studs with a hammer. **Do not loosen the studs in the spindle with tool pressure alone.**

8. Remove the stud nuts and the spindle from both studs.

INSTALLATION

1. Position the new spindle to the upper and lower ball joint studs, install the stud nuts, and tighten the nuts to specifications. Continue to tighten both nuts until the cotter pin holes line up with the slots, then install new cotter pins.

2. Connect the spindle connecting rod end to the spindle arm, and install the retaining nut. Tighten the nut to specifications, align slot and install cotter pin.

3. Assemble the brake carrier plate, gaskets, and dust shield to the spindle, install the retaining bolts and nuts, and tighten to specifications (Fig. 1).

4. Install the wheel, hub, and drum, and adjust the wheel bearing.

5. Lubricate the steering stop on the lower arm and the mating flat on the spindle with specified lubricant.

6. Remove the safety stands, lower the car, and check camber, caster, and toe-in.

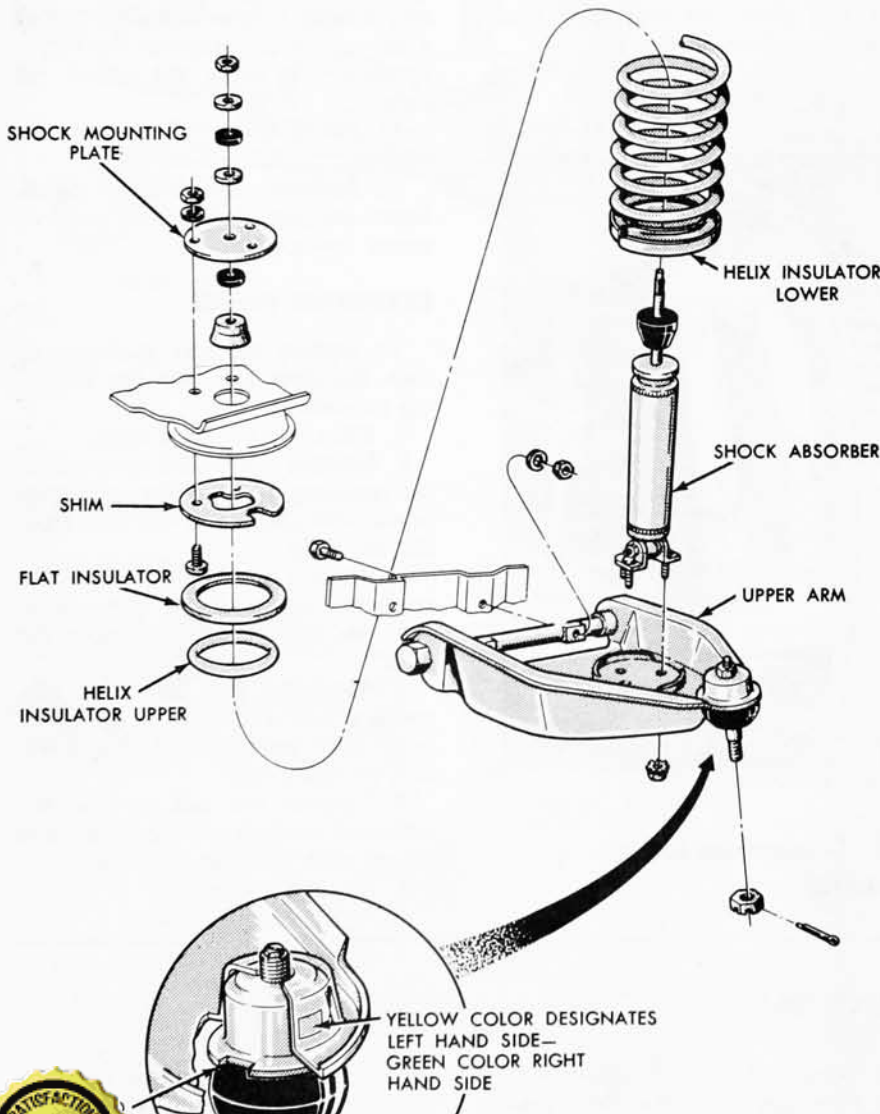

F1206-A

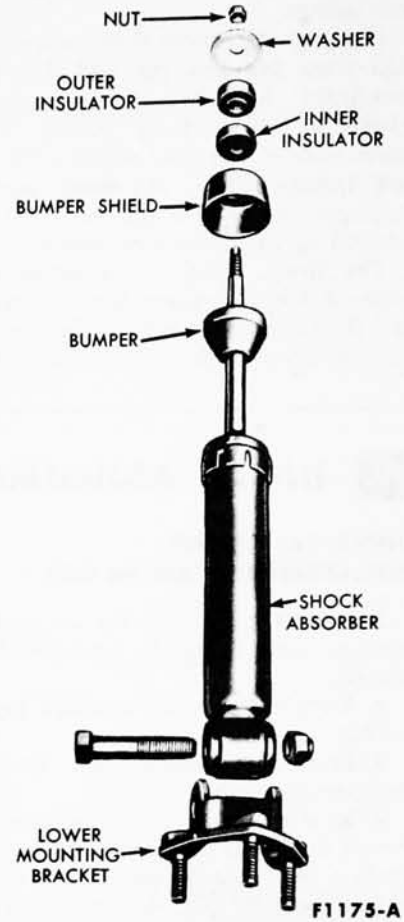

F1175-A

FIG. 5—Front Shock Absorber—Exploded View

FRONT SHOCK ABSORBER

REMOVAL

1. Raise the front of the car, position a safety stand under the lower suspension arm, then lower the car slightly.

2. Disconnect the shock absorber lower mounting bracket from the upper arm by removing the three retaining nuts and washers (Fig. 4).

3. Open the hood, then remove the three shock absorber upper mounting plate retaining nuts and the two bolts that attach the mounting plate to the dash panel brace. Remove the shock absorber, mounting plate, and lower bracket as an assembly.

INSTALLATION

1. Position the shock absorber and upper mounting plate assembly through the top of the spring housing so that the three lower mounting studs enter the holes in the suspension upper arm. Install the lower retaining nuts on the studs.

100% SATISFACTION GUARANTEED

BUY IT NOW!

Click Here To Order

Spring Connections

PayPal, American Express, Discover, MasterCard, VISA

2. Install the two bolts that attach the mounting plate to the dash panel brace. Install the three mounting plate retaining nuts.

3. Remove the safety stands, and lower the car.

REPLACEMENT

1. Remove the front shock absorber as outlined under "Removal."

2. Remove the shock absorber upper retaining nut, washer and insulator, then separate the shock absorber from the upper mounting plate (Fig. 5).

3. Remove the retaining nut and bolt, and transfer the lower mounting bracket to the replacement shock absorber.

4. Install the bumper and shield, and the inner insulator on the shock absorber upper mounting stud. Assemble the upper mounting plate, then the outer insulator, washer and retaining nut to the mounting stud.

5. Install the shock absorber as outlined under "Installation."

FRONT SPRING

REMOVAL

1. Raise the front of the car, position safety stands under the suspension lower arms, then lower the car slightly.

2. Remove the wheel and tire assembly. Remove the front shock absorber as described in steps 2 and 3 under "Removal" in the foregoing procedure.

3. Raise the car slightly in order to lower the suspension upper arm. Install spring tool T63P-5310-A. Slide the tool bearing and upper plate over the shaft screw against the shaft nut. Insert the tool assembly through the upper opening in the spring housing so that the shaft screw goes through the top of the coil spring with the tool upper plate holes going over the studs as shown in Fig. 6.

4. From under the car, place the tool lower plate under the fourth coil from the bottom. Secure the plate to the coil by installing the tool retainer in the groove in the shaft screw (Fig. 7).

5. Insert a 1/2-inch square drive flex-handle wrench in the drive hole

washers that retain the upper arm inner shaft to the chassis, and swing the arm out of the way. The arm pivots on the ball joint.

7. Remove the bolt that retains the clip and brake line to the chassis, then move the brake line out of the way.

8. Disconnect the stabilizer bar from the link at both left and right hand suspension lower arms by removing the bar-to-link retaining nuts and upper bushings (Fig. 1). Position the bar out of the way.

9. Fully release the spring tension by turning the tool shaft nut counterclockwise (Fig. 6). Be sure to hold the lower plate of the tool with the 1/2-inch square drive flex-handle wrench so that the tool will not turn or snap loose during spring release (Fig. 7).



FIG. 6—Compressing or Releasing Spring—Upper View

10. Remove the spring tool, then remove the spring from the car.

INSTALLATION

1. On cars equipped with air conditioning, install the tapered shim in the top of the spring housing with the thick portion of the shim toward the centerline of the car. Retain the shim in the housing with tape.

2. Insert one helix-type insulator between the two top coils of the spring and attach the other to the bottom coil (Fig. 8). Secure both

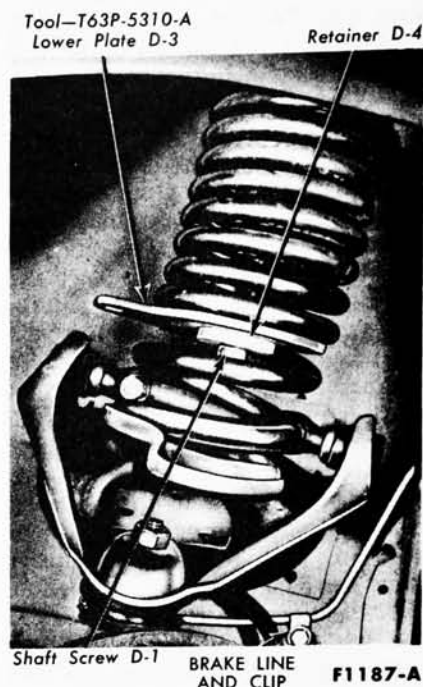

FIG. 7—Compressing or Releasing Spring—Lower View

insulators with tape.

3. Place the flat rubber insulator over the top of the spring (Fig. 4), and secure it with tape in three places.

4. Assemble the upper components of tool T63P-5310A by sliding the tool bearing and the upper plate over the shaft screw against the

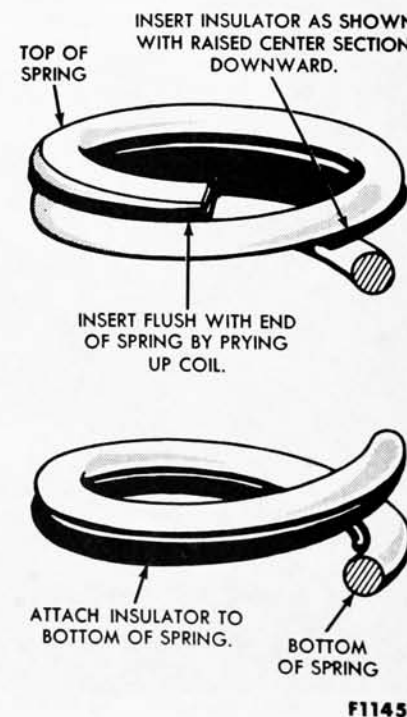

FIG. 8—Front Spring Insulator Installation



BUY IT NOW!

Click Here To Order



shaft nut. Position the spring from under the car so that its upper end is seated in the spring housing. Insert the tool assembly through the upper opening in the spring housing so that the shaft screw goes through the top of the coil spring with the tool upper plate holes going over the studs as shown in Fig. 6.

5. From under the car, place the tool lower plate under the fourth coil from the bottom. Secure the plate to the coil by installing the tool retainer to the groove in the tool shaft screw.

6. Compress the spring by turning the tool shaft nut clockwise (Fig. 6). Hold the tool lower plate from turning during spring compression. Use the 1/2-inch square drive flex-handle wrench.

7. Position the stabilizer bar on the left and right-hand links and install the rubber bushings and nuts (Fig. 1).

8. Position the brake line and clip on the chassis and install the retaining bolt.

9. Swing the upper arm into position and install the arm inner shaft-to-chassis retaining nuts. **Do not tighten.**

10. **Partially** release the spring tension by turning the shaft nut of tool T63P-5310-A counterclockwise (Fig. 6). As the spring is being released, pry the lower coil so that it will seat in the groove of the upper arm. **Hold the tool lower plate with the square drive wrench.**

11. Tighten the upper arm inner shaft-to-chassis retaining nuts to specifications. Release the spring completely, then remove the tool. **Hold the tool lower plate from turning during spring release. Use the 1/2-inch square drive flex-handle wrench.**

12. With the safety stands placed under the suspension lower arms, lower the car enough to compress the spring slightly.

13. Position the shock absorber and upper mounting plate assembly through the top of the spring housing so that the three lower mount-

ing studs enter the holes in the suspension upper arm. Install the lower retaining nuts on the studs.

14. Install the two bolts that attach the mounting plate to the dash panel brace. Install the three mounting plate retaining nuts.

15. Install the wheel and tire assembly. Remove the safety stands. Check caster, camber and toe-in.

UPPER ARM

REMOVAL

1. Remove the shock absorber and coil spring assemblies, and disconnect the arm inner shaft from the chassis as outlined in the "Front Spring" procedure under "Removal."

2. Remove the cotter pin and loosen the upper ball joint stud nut. Place a box wrench over lower end of tool T57P-3006-A as shown in Fig. 3. **The tool should seat firmly against the ends of both studs and not against the lower stud nut.** It may be necessary to remove the cotter pin from the lower ball joint stud if the cotter pin prevents the tool from seating on the lower stud.

3. Turn the wrench until both studs are under tension, then loosen the upper stud from the spindle by tapping the spindle near the upper stud with a hammer. **Do not loosen the stud with tool pressure alone.** Remove the upper stud nut, and disengage the upper ball joint and stud from the spindle. Remove the upper arm from the car.

INSTALLATION

1. Position the arm on the car by inserting the upper ball joint stud in the spindle upper bore. Install the stud nut. Tighten the nut to specifications, then continue to tighten until the cotter pin holes are aligned with the slots. Install a new cotter pin.

2. Install the coil spring, connect the upper arm inner shaft to the chassis, and install the shock absorber. Follow the steps in the "Front Spring" procedure under "Installation."

LOWER ARM

REMOVAL

1. Raise the front of the car, and install safety stands.

2. Remove the wheel, hub, and drum assembly.

3. Remove the four retaining bolts and nuts, and remove the brake carrier plate from the spindle. Support

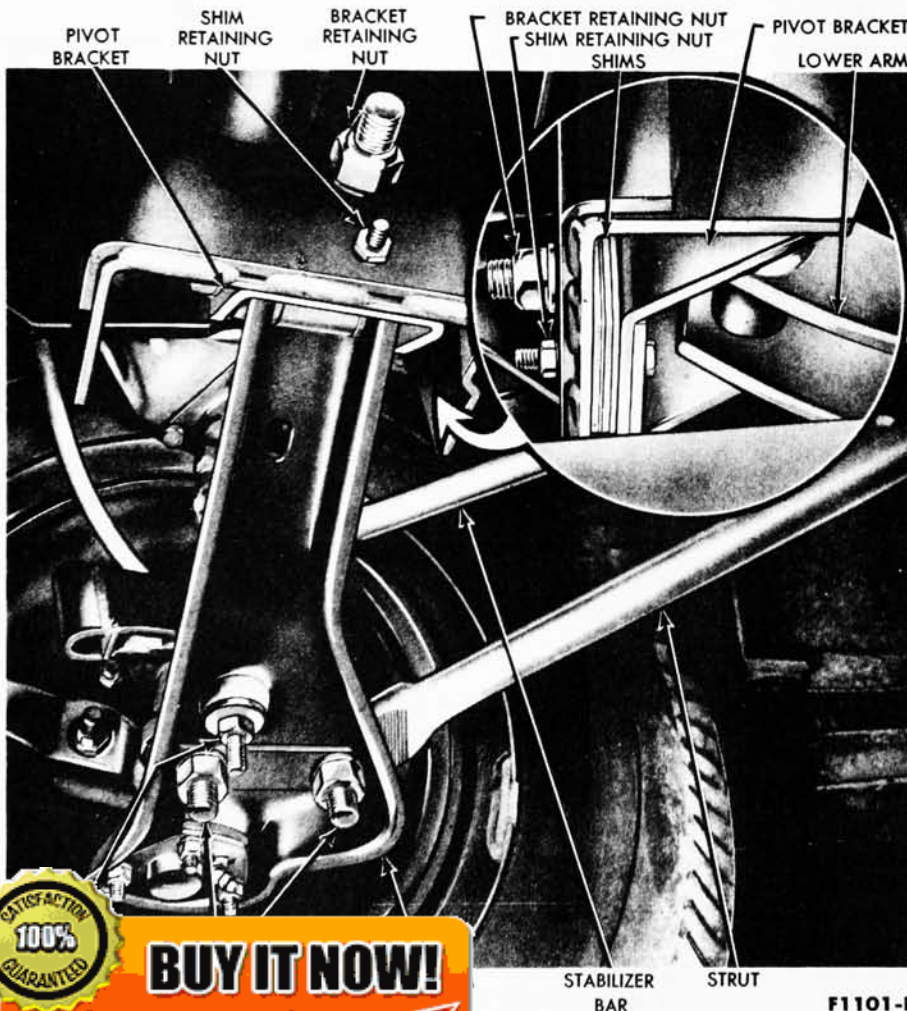

F1101-B

100% SATISFACTION GUARANTEED

BUY IT NOW!

Click Here To Order

PayPal | American Express | Discover | MasterCard | VISA

the brake assembly with wire to relieve the weight on the brake hose.

4. Remove the link nut underneath the arm (Fig. 9), and disconnect the stabilizer link from the arm.

5. Remove the retaining nuts, bolts, washers and plates, and disconnect the strut from the lower arm (Fig. 9).

6. Remove the cotter pin and loosen the lower ball joint stud nut. Place a box wrench over the end of tool T57P-3006-A, and position the tool 180° from the position shown in Fig. 3 (wrench at the top). The tool should seat firmly against the ends of both studs, not against the upper stud nut. It may be necessary to remove the cotter pin from the upper ball joint stud if the cotter pin prevents the tool from seating on the upper stud.

7. Turn the wrench until both studs are under tension, then loosen the stud from the spindle by tapping the spindle near the lower stud with a hammer. **Do not loosen the stud with tool pressure alone.** Disengage the lower ball joint and stud from the spindle.

8. Remove the pivot bracket retaining nut and the shim retaining nut (Fig. 9), then remove the bracket and lower arm assembly from the car.

9. Place the assembly in a vise and remove the nut from the pivot bolt (Fig. 10). Remove the pivot

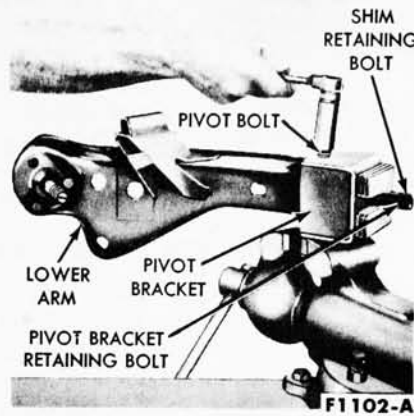

FIG. 10—Lower Suspension Arm Assembly

bolt, and separate the pivot bracket from the lower arm.

INSTALLATION

1. Assemble the pivot bracket to the new lower arm with the pivot bolt, place the assembly in a vise, and install the pivot bolt nut (Fig. 10). Tighten the nut snug. Do not torque it until the lower arm assembly is installed in the car.

2. Slide the shims over the retaining bolts against the pivot bracket (Fig. 10), then mount the lower arm and pivot bracket assembly to the chassis mounting bracket (Fig. 9). Install the pivot bracket and shim retaining nuts.

3. Insert the lower ball-joint stud in the lower bore of the wheel spindle, and install the stud nut. Tighten the nut to specifications, then continue to tighten until the cotter pin holes are aligned with the slots. Install a new cotter pin.

4. Position and connect the lower arm strut to the lower suspension arm with retaining plates, bolts, washers, and nuts (Fig. 9). Torque the nuts.

5. Connect the stabilizer bar link to the lower suspension arm, and install the washers, bushings and link retaining nut. Tighten the nut to specifications.

6. Tighten the pivot bolt and nut at the lower arm pivot bracket to specifications.

7. Lubricate the steering stop on the lower arm and the mating flat on the spindle. Refer to Group 19 for specified lubricant.

8. Install the brake carrier plate and dust shield on the spindle and tighten the retaining nuts to specifications.

9. Install the wheel, hub, and drum assembly.

10. Remove the safety stands, lower the car, and check the camber, caster, and toe-in.

REAR SHOCK ABSORBER

REMOVAL

1. Raise the rear end of the car.

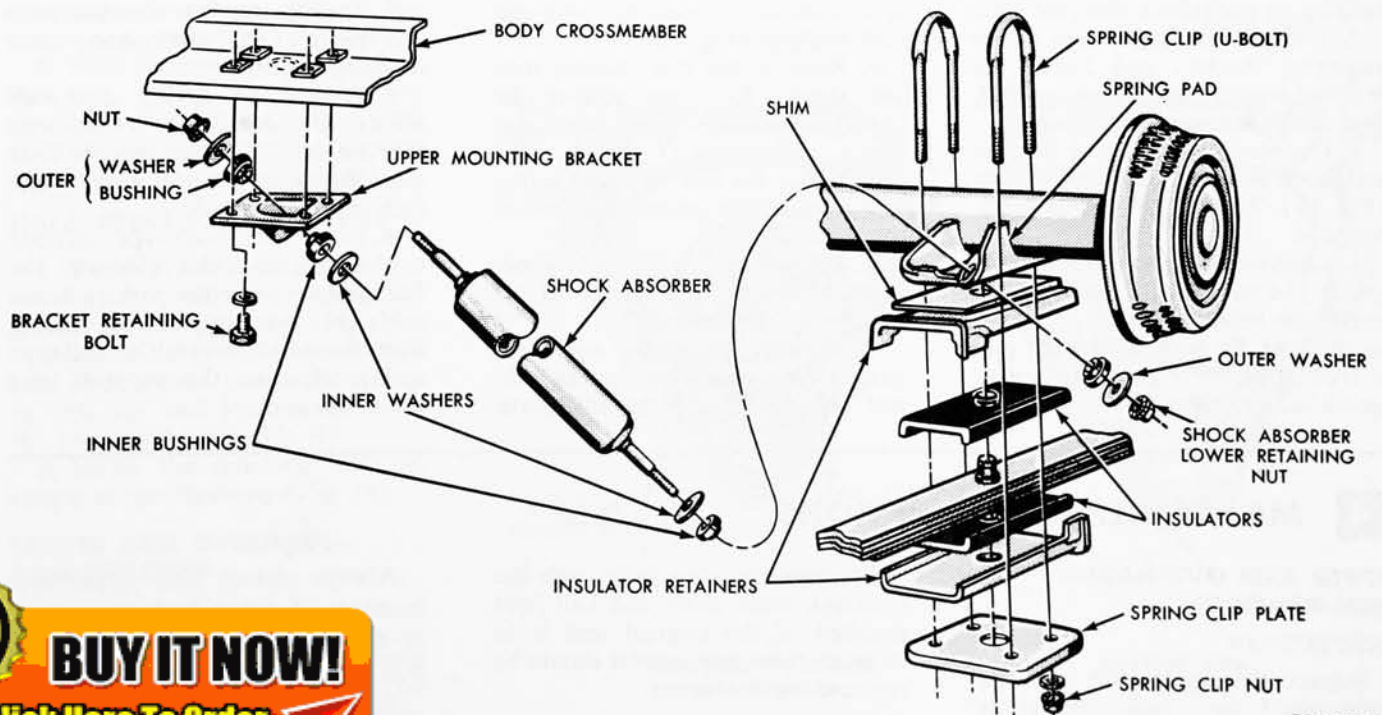

100% SATISFACTION GUARANTEED

BUY IT NOW!

Click Here To Order

PayPal, American Express, Discover, MasterCard, VISA

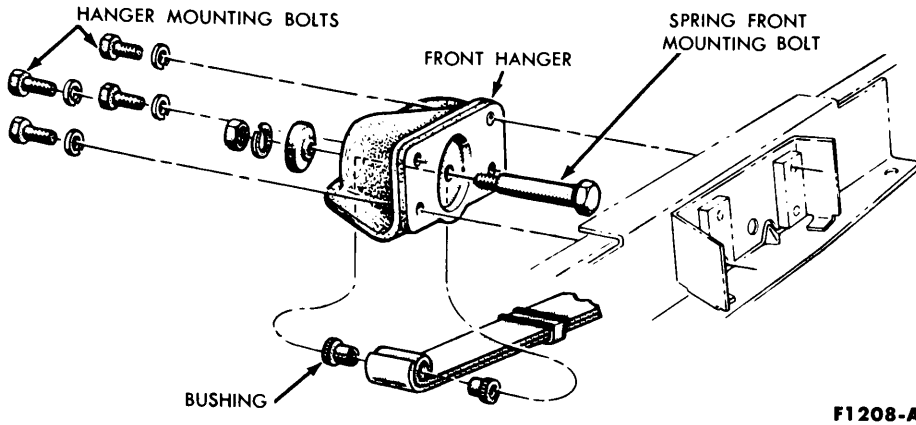

FIG. 12—Rear Spring and Front Hanger Mounting

Remove the bolts that retain the shock absorber mounting bracket to the underbody (Fig. 11).

2. Remove the retaining nut, outer washer and bushing from the shock absorber at the spring pad on the axle housing. Compress the shock absorber and remove it from the car.

3. Remove the nut, outer washer, and bushing that retain the shock absorber to the mounting bracket, and remove the bracket.

4. If the shock absorber is serviceable and requires new bushings, remove the inner bushings and washers from the shock absorber studs.

INSTALLATION

1. Place the inner washer and bushing on each shock absorber stud.

2. Connect the upper stud to the mounting bracket, and install the bushing, washer, and nut on the stud. Torque the nut to specifications.

3. Connect the mounting bracket and shock absorber to the underbody (Fig. 13). Torque the bolts to specifications.

4. Connect the lower stud to the spring pad on the axle housing, and install the bushing, washer, and nut on the stud. **Be sure the spring pad is free of burrs.** Tighten the nut to specifications.

REAR SPRING

REMOVAL

1. Raise the car until the rear wheels clear the floor, and place supports beneath the underbody.

2. Remove the anti-rattle coil-type spring that retains the parking brake cable to the rear spring. Remove the hook-type retainer from the brake cable and spring clip (U-bolt).

3. Place a jack and a block of wood underneath the spring clip plate, then raise the center of the spring to reduce the tension.

4. Remove the spring clip (U-bolt) nuts (Fig. 11), then lower the jack enough to remove the spring clips.

5. Remove the spring front hanger-to-underbody mounting bolts and lock washers (Fig. 12).

6. Remove the rear shackle nuts and shackle bar, then remove the shackle assembly from the rear hanger and spring (Fig. 13).

7. Lower the jack until the spring and front hanger assembly is free of the car.

8. Lift the shim (if used), upper insulator retainer, and insulator from the top of the spring.

9. Remove the spring and front hanger as an assembly from the jack, and separate the spring clip plate,

lower insulator retainer, and insulator from the spring.

INSTALLATION

1. Position the lower insulator, retainer, and spring clip plate on the center of the spring with the retainer flange rearward. Place the entire assembly on a wood block and jack, then raise the jack until the spring is in mounting position.

2. Position the rear eye of the spring on the rear hanger and install the shackle assembly to the spring and hanger (Fig. 13). The rear eye is at the long end of the spring from the center tie bolt. Install the shackle bar and retaining nuts. **Do not tighten the nuts at this time.**

3. Position the spring and front hanger assembly on the underbody, and install the hanger mounting bolts (Fig. 12). Do not tighten the bolts at this time.

4. Install the upper insulator and retainer on the spring with the retainer flange forward (Fig. 11). Install the axle shim if one was used.

5. Raise the jack until the center of the spring, the insulators, the retainers, and the spring clip plate are all properly aligned and positioned against the spring pad on the axle housing (Fig. 11).

6. Install the spring clips over the axle housing and through the holes in the spring clip plate. Install the spring clip nuts, but do not tighten at this time.

7. Torque the rear shackle nuts and the front hanger mounting bolts to specification.

8. Torque the spring clip nuts evenly to specification. Make sure that the lower insulator retainer contacts the upper retainer. Remove the jack and wood block.

9. Install the hook-type retainer to the parking brake cable and the spring clip. Secure the parking brake cable to the top of the spring with the small anti-rattle, coil-type spring. Remove the supports and lower the car.

4 MAJOR REPAIR OPERATIONS

Replacement arms come with the bushings, inner shaft, and ball joint installed. If the original arm is to be used, these components should be replaced on the bench.

BUSHING AND INNER SHAFT REPLACEMENT

Always replace both upper arm bushings, if either bushing is worn or damaged. Install only new bushings when replacing the inner shaft.

1. Position the upper arm inner shaft in a vise, then unscrew the bushings from the shaft and arm. Re-

ARM OVERHAUL—MOVED

100% SATISFACTION GUARANTEED

BUY IT NOW!

Click Here To Order

PayPal American Express Discover Novus MasterCard VISA

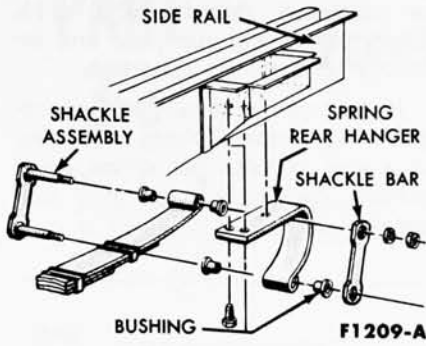

FIG. 13—Rear Spring and Rear Hanger Mounting

move the assembly from the vise, and separate the inner shaft from the arm.

2. Position the shaft in the arm, apply grease to the new bushings, and install the bushings loose on the shaft and arm. **Turn the bushings so that the shaft is exactly centered in the arm.** The shaft will be properly centered when located at the dimension shown in Fig. 14.

3. Fabricate a 9/4-inch spacer from a section of 3/4-inch diameter pipe or metal of comparable size and strength.

4. Position the arm and inner shaft assembly in a vise. Position the spacer parallel with the inner shaft, and force the spacer between the flanges of the upper arm.

If the spacer can not be forced between the arm flanges due to excessive distortion, replace the upper arm assembly.

5. With the spacer positioned in the arm, torque the bushings to specification. Pivot the arm on the shaft to be sure that no binding exists, then remove the spacer.

BALL JOINT REPLACEMENT

1. Remove the ball joint-to-arm retaining nut and remove the ball joint from the upper arm (Fig. 14).

2. Install the replacement ball joint in its recess in the upper arm so that the ball joint notch faces the front of the car (Fig. 4).

3. Install the retaining nut and torque to specifications (Fig. 14).

LOWER ARM OVERHAUL—ARM REMOVED

INSPECTION

stud, and turn the stud in the ball joint with a torque wrench. If the turning effort is not within specifications, replace the ball joint.

Replacement arms come with the ball joint installed. If the original arm is to be used, the ball joint should be replaced on the bench.

BALL JOINT REPLACEMENT

The lower ball joint cannot be repaired and must be replaced if it is worn or damaged.

1. Remove the lower arm as outlined in the "Lower Arm" procedure under "Removal".

2. Remove the ball joint from the arm. If the ball joint is riveted to the arm, drill a 1/8-inch pilot hole completely through each rivet, and then drill off the rivet head through the pilot hole with a 3/8-inch drill. Drive all rivets out of the holes.

3. Clean the end of the arm, and remove all burrs from the hole edges. Check for cracks in the metal at the holes, and replace the arm if it is cracked.

4. Install a new ball joint on the arm. **Use only the specified bolts, nuts, and washers. Do not attempt to rivet the new ball joint to the arm.**

5. Torque the ball joint retaining

nuts and bolts to specifications.

6. Install the lower arm as outlined in the "Lower Arm" procedure under "Installation".

REAR SPRING OVERHAUL—SPRING REMOVED

FRONT HANGER ASSEMBLY

If the front hanger or bushings are to be replaced, proceed as follows:

1. Remove the nut, lock washer and insulator from the spring front mounting bolt (Fig. 12).

2. Tap the spring mounting bolt out of the bushings and hanger, then separate the hanger from the spring. Remove the bushings.

3. Position the bushings in the front eye of the spring. Assemble the front hanger to the spring eye and install the spring mounting bolt through the hanger, bushings, and spring eye as shown in Fig. 12.

4. Install the insulator, lock washer, and nut on the mounting bolt and tighten to the specified torque.

REAR SHACKLE AND HANGER ASSEMBLY

Inspect the rear shackle, bushings, and studs for wear or damage. Replace parts where necessary (Fig. 13).

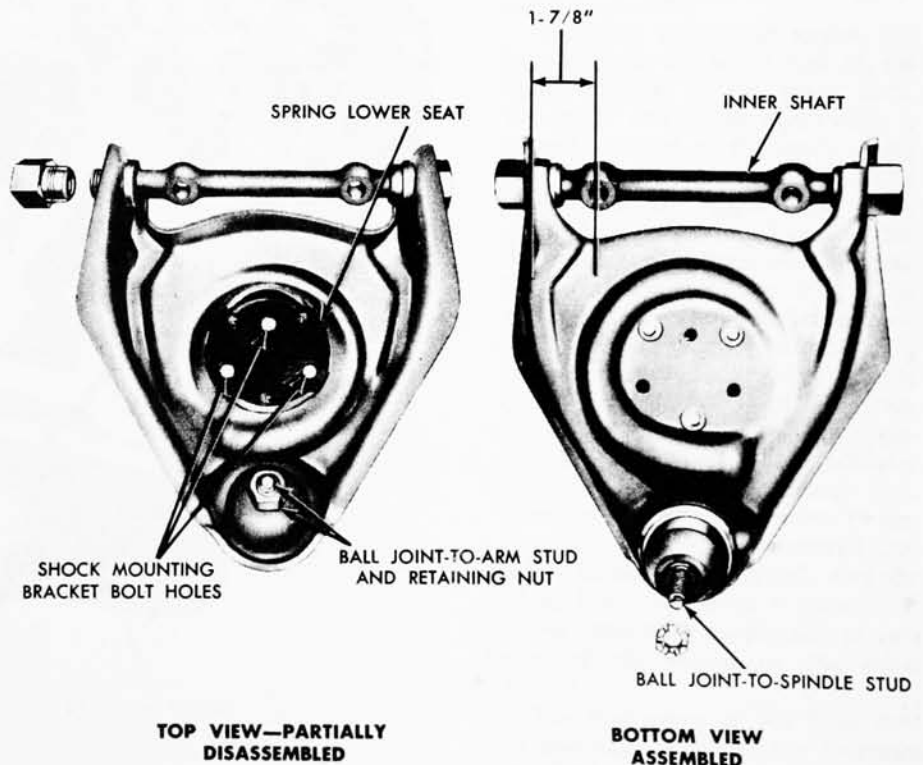

FIG. 14—Upper Suspension Arm

100% SATISFACTION GUARANTEED

BUY IT NOW!

Click Here To Order

PayPal, American Express, Discover, MasterCard, VISA

F1210-A

If the rear shackle bushings are to be replaced, it will be necessary to remove the rear hanger assembly. Torque the hanger attaching bolts to specification when re-installed.

SPRING LEAVES AND TIE BOLT

Check for broken spring leaves. Inspect the anti-squeak inserts between the leaves, and replace them if they are worn. **The spring leaves must be dry and free of oil and dirt before new inserts are installed.**

Inspect the spring clips for worn

or damaged threads (Fig. 11). Check the spring clip plate and insulator retainers for distortion.

If the spring center tie bolt requires replacement, clamp the spring in a vise to keep the spring compressed during bolt removal and installation.



PART 3-3 STEERING

Section	Page	Section	Page
1 Description and Operation	3-15	3 Removal and Installation	3-23
2 In-Car Adjustments and Repairs	3-17	4 Major Repair Operations	3-24

1 DESCRIPTION AND OPERATION

TORSION BAR STEERING GEAR

The power steering unit is a torsion-bar type of hydraulic assisted system. This system furnishes power to reduce the amount of turning effort required at the steering wheel. It also reduces road shock and vibrations.

The torsion bar power steering unit includes a rack and piston, and a worm and ball nut assembly which is meshed to the gear on the steering sector shaft. The unit also includes

a hydraulic valve, valve sleeve, and torsion bar assembly which are mounted on the end of the worm shaft and operated by the twisting action of the torsion bar.

The torsion-bar type of power steering gear is designed with all components in one housing (Fig. 1). This makes possible internal fluid passages between the valve and cylinder, thus eliminating all external lines and hoses, except the pressure and return hoses between the

pump and gear assembly.

The power cylinder is an integral part of the gear housing. The piston is double acting, in that fluid pressure may be applied to either side of the piston. The one-piece piston and power rack is meshed to the sector shaft.

The operation of the hydraulic control valve is governed by the twisting of a torsion bar. All effort applied to the steering wheel is transmitted directly through the torsion bar to the ball nut and worm assembly. Any resistance to the turning of the front wheels results in twisting of the bar. The twisting of the bar increases as the front wheel turning effort increases. The control valve spool, actuated by the twisting of the torsion bar, directs fluid to the side of the piston where hydraulic assist is required.

The lower end of the torsion bar is splined to the lower end of the inside diameter of the worm shaft. The upper end of the worm shaft is coarsely splined to the inside diameter of the torsion bar and input shaft assembly upper end. This spline fit is sufficiently loose so that the upper end of the torsion bar and input shaft assembly can twist in the actuator, and thus move the actuator up and down. This movement results from a short length of helical splines on the inside diameter of the actuator which engage the outside diameter of the input shaft. The actuator is held in the spool by a snap ring. Therefore, as the torsion bar twists, its radial motion is transferred into axial motion by helical threads. Thus, the valve spool is moved off center, and fluid is directed to one side of the piston or the other (Fig. 2).

The restricting of the fluid flow to one side of the piston increases the fluid pressure proportionately to the reaction of turning the front wheels.

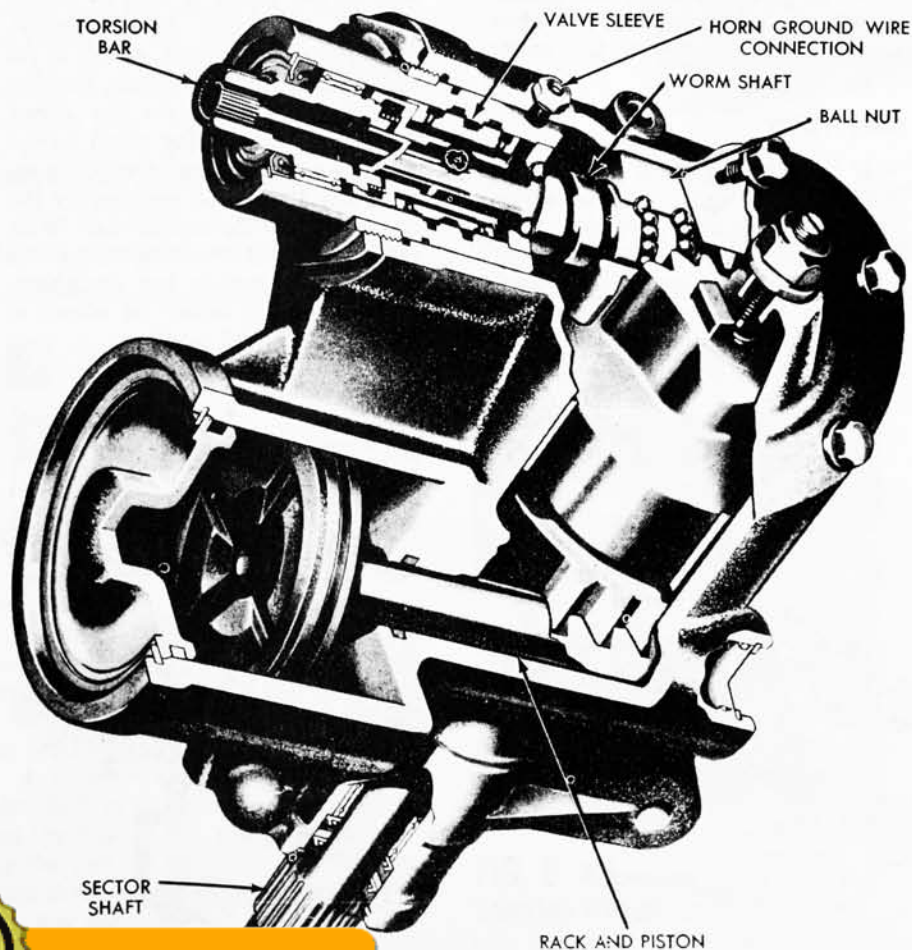

G1087-B



BUY IT NOW!

Click Here To Order

The resistance of the torsion bar gives the driver a feel of the road at all times. The more the torsion bar twists, the greater the feel of the road and at the same time the driver is receiving a greater power assist in steering.

STRAIGHT-AHEAD POSITION

When the power unit is not assisting in the steering effort, the valve spool is in the neutral, or straight-ahead position (Fig. 3). The fluid flows from the pump, through the open-center valve, and returns to the pump through the worm bearing. Therefore, no area of the valve spool or steering gear is under high pressure in this position. The amount of pressure in neutral position is approximately 30 psi at normal operating temperatures.

The pump has no influence on the valve spool, but the spool, housing, and power cylinder are full of fluid at all times when the pump operates.

RIGHT TURN

When the steering wheel is turned to the right, the ball nut on the worm resists being turned due to load on the sector shaft from the front end weight of the vehicle. Thus the torsion bar will start to twist (Fig. 3).

For a right turn the valve spool moves **up**, allowing fluid from the pump to enter against the upper side of the power piston. The fluid on the lower side of the piston is free to return through the valve to the

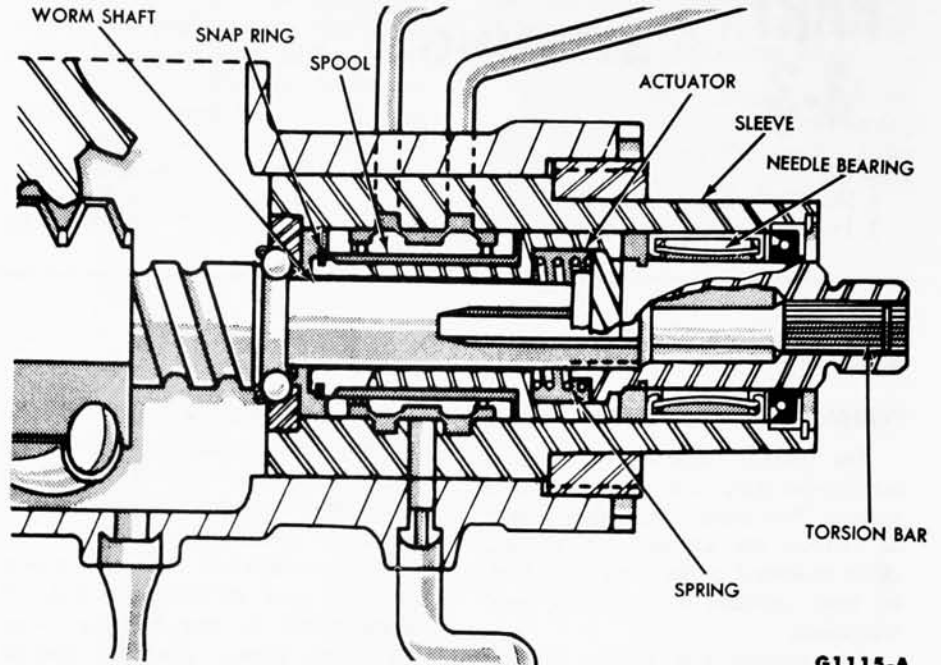

FIG. 2—Valve Detail

G1115-A

pump. Therefore, the power assist is to the upper side of the piston, pushing it downward and providing assistance in turning of the sector shaft.

LEFT TURN

If the steering wheel is turned to the left, it will cause a similar action but in the opposite direction (Fig. 3). The torsion bar twists to the left, moving the valve spool **downward**, allowing fluid from the pump to enter against the lower side of the

power piston. The fluid on the upper side of the piston is free to return through the valve to the pump. Therefore, the power assist is to the lower side of the piston, pushing it upward. The instant the driver stops applying steering effort to the steering wheel the valve spool is returned to its neutral position by the unwinding of the torsion bar. With the valve spool returning to neutral position, the torsion bar straightening also helps to return the wheels to the straight-ahead position.

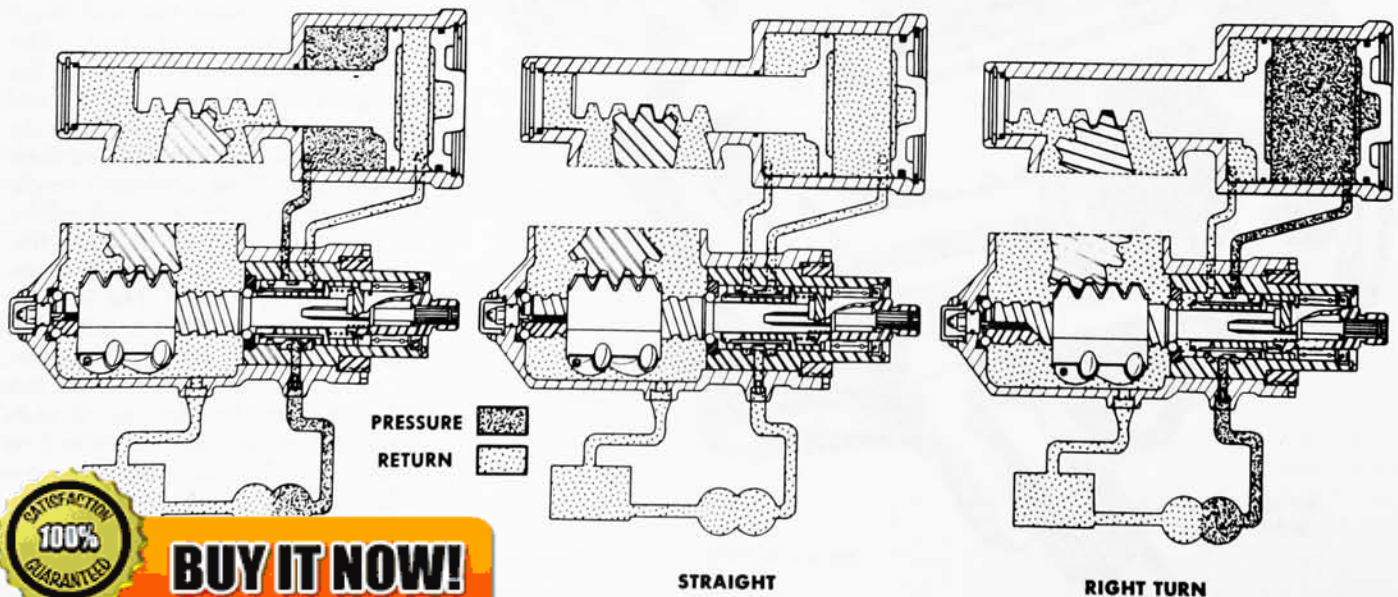

G1114-B

100% SATISFACTION GUARANTEED

BUY IT NOW!

Click Here To Order

PayPal, American Express, Discover, MasterCard, VISA

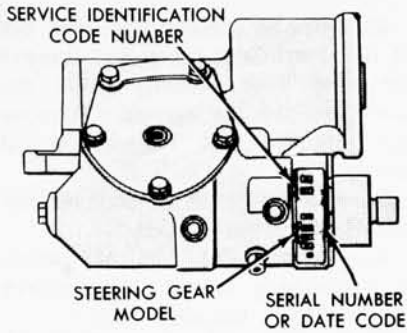

FIG. 4—Steering Gear Identification Tag G1175-A
PUMP

The roller-type hydraulic pump, belt-driven from the engine crankshaft, draws automatic transmission fluid from the reservoir and provides fluid pressure for the system. Steering gear lubrication is also provided by the same fluid from the reservoir. Within the pump itself is a flow-control and pressure-relief valve which governs the pressures within the steering system according to the varying conditions of operation. After fluid has passed from the gear, it returns to the reservoir.

An identification tag is attached to the machined pad on top of the steering gear housing (Fig. 4) with a self-tapping screw.

MOVABLE STEERING COLUMN

The movable column combines a lateral-movement mechanism (Fig.

5) at the instrument panel with a flexible coupling that attaches to the steering gear input shaft. The steering column lower end pivots on a bracket that is fastened to the dash panel.

With the column in the straight-ahead position and the gear shift lever at any position other than P, the column is locked to the brake pedal support assembly. It is locked by a locking lever controlled by the selector tube. A coil spring provides positive engagement of the locking bracket when the shift lever is at any position other than P.

When the selector lever is moved to park position, a cam latch (fastened to the selector tube) disengages the locking lever from the locking bracket. The steering column assembly may then be moved about 8 inches to the right. Whenever the locking lever is disengaged, and the column is moved over, the transmission cannot be shifted. As the column is moved back to its extreme left (or straight-ahead) position, the locking lever engages the bracket, locking the column and the transmission can be shifted by the selector lever.

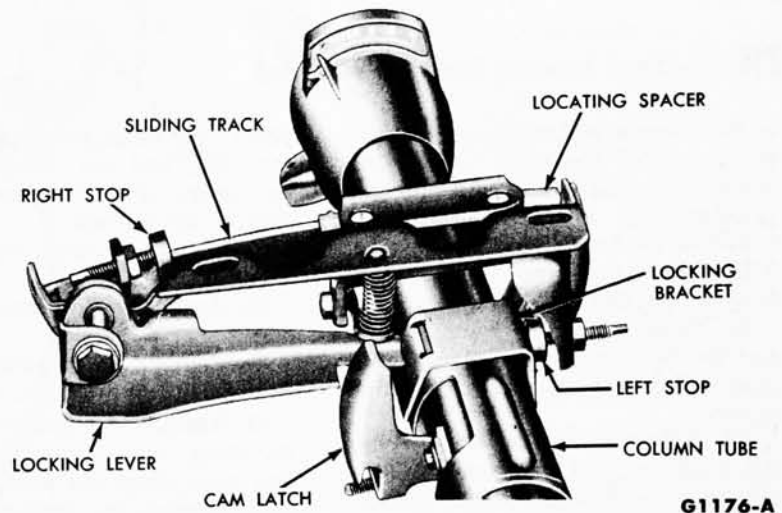

FIG. 5—Movable Steering Column Mechanism G1176-A

2 IN-CAR ADJUSTMENTS AND REPAIRS

STEERING WHEEL SPOKE POSITION

See Part 3-1 for this adjustment.

STEERING WHEEL REPLACEMENT

1. Remove the hub cap from the steering wheel.
2. Remove the steering wheel nut, and then remove the steering wheel with a puller as shown in Fig. 6.
3. Transfer all serviceable parts to the new steering wheel.
4. Position the steering wheel on the shaft so that the alignment mark on the hub of the wheel is adjacent to the one on the shaft. Install and torque the nut to specification. Stake the nut securely.

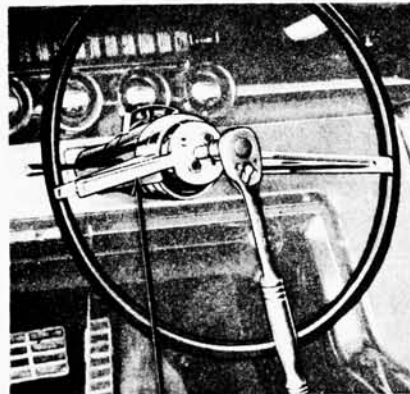

Tool—3600-N

G1177-A

FIG. 6—Removing Steering Wheel

the upper bearing spring.

2. Remove the turn signal lever from the switch.
3. Remove the three turn signal

clamp attaching screws.

4. Remove the three bearing retainer attaching screws and remove the retainer (Fig. 7).

5. Carefully lift the turn signal switch from the column. Use care to move the attaching wires only enough for the switch to clear the shaft.

6. Working from the engine compartment, disconnect the upper steering shaft from the flexible coupling.

7. Lift the upper shaft and bearing from the column.

8. Remove the bearing from the upper end of the shaft. Remove the rubber insulator from the bearing.

9. Slide a new bearing onto the upper end of the shaft until it contacts the "C" ring.

Install the rubber insulator on the bearing outer race.

10. Install the shaft and bearing

100% SATISFACTION GUARANTEED

BUY IT NOW!

Click Here To Order

PayPal American Express Discover Novus MasterCard VISA

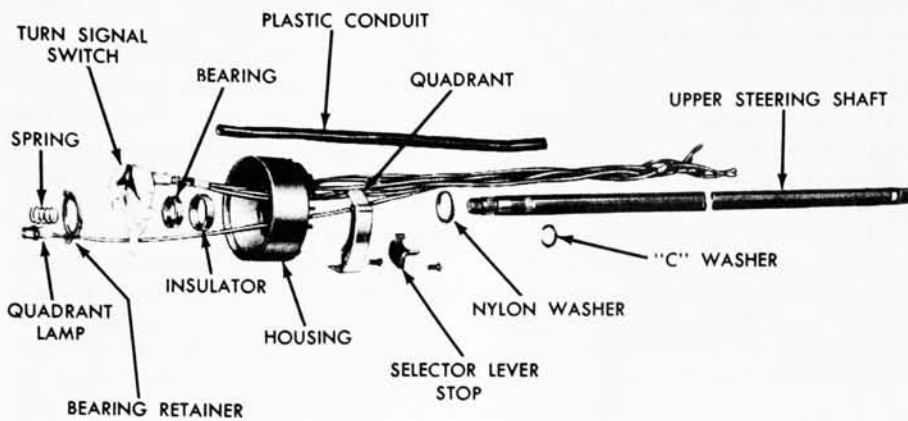

G1178-A

FIG. 7—Upper Steering Shaft Disassembled

in the column making sure that the lower end of the shaft enters the flexible coupling in the engine compartment and that the bearing is seated in the bore.

11. Secure the upper shaft to the flexible coupling.

12. Position the turn signal switch and the bearing retainer in the column and install the three attaching screws.

13. Pull the turn signal wires from the lower end of the column just enough to remove all slack. Install the thru wire retaining clips.

14. Install the turn signal lever.

15. Install the upper bearing spring and the steering wheel.

SHIFT TUBE AND LEVER REPLACEMENT

REMOVAL

1. Disconnect the ground cable from the battery.

2. Working from under the hood, remove the two steering column tube bracket attaching bolts (Fig. 8).

3. Disconnect the shift rod from the selector lever at the lower end of the steering column.

4. Remove the bolt that secures the steering shaft to the flexible coupling.

5. Remove the steering wheel, the upper bearing spring, the turn signal switch retainer, and the turn signal lever.

6. Fully lift the turn signal

panel, rear panel moulding, left side moulding and the two lower edge mouldings (Fig. 8) from the left side of the console.

9. Remove the lower edge moulding retainers.

10. Remove the radio access cover.

11. Remove the headlamp switch and bezel from the instrument panel.

12. Remove the instrument panel moulding cover attaching screws and cover from the panel.

13. Remove the instrument panel finish panel attaching screws and remove the finish panel.

14. Remove the dust boot retainer-to-dash attaching bolts.

15. Disconnect the turn signal wires at the connector.

16. Disconnect the two wires and the two vacuum hoses from the neutral safety switch.

17. Remove the two steering column-to-track attaching bolts.

18. Remove the two screws that attach the lower half of the cover to the column and remove the cover.

19. Remove the clip that secures the two door actuating levers to the pivot bracket (Fig. 8). Carefully remove the doors from the column.

20. Remove the two bolts that secure the pivot bracket to the instrument panel and remove the bracket.

21. Remove the three screws that secure the locking cam to the selector lever tube (Fig. 10) and remove the cam.

22. Remove the two neutral switch attaching screws and remove the switch.

23. Lift the column part way out of the instrument panel and remove the dust boot retainer from the lower end of the column. Remove the column from the instrument panel.

24. Remove the selector lever roll pin, then remove the lever.

25. Remove the neutral switch stop attaching screws and remove the stop from the shift tube.

26. Remove the screw that attaches the shift lever tube to the hub.

27. Slip the shift tube and lever from the lower end of the column.

28. Spread the nylon bushing enough to clear the neutral switch mounting pad then remove it from the tube. Pull the nylon centering cone from the lower end of the tube with pliers.

INSTALLATION

1. Work the plastic centering cone into the lower end of the shift lever tube making sure that the taper is toward the bottom of the tube.

2. Slide the nylon bushing to the lower end of the tube spreading only enough to provide clearance at the neutral safety switch mounting pad.

3. Slide the shift tube and lever into the lower end of the column until the upper end enters the selector lever hub and the molded stop is in the slot in the tube.

4. Secure the shift tube to the selector lever hub with the attaching screw (Fig. 10).

5. Secure the neutral switch stop to the shift tube with the attaching screws.

6. Position the selector lever in the hub and secure it with a roll pin. Install the nylon locating spacer on the track (Fig. 11).

7. Enter the lower end of the column in the instrument panel opening and install the dust boot retainer on the column. Continue to lower the steering column until the mounting bracket is on the engine compartment side of the dash panel.

8. Install, but do not tighten the bracket attaching bolts.

9. Secure the column to the track with the two attaching bolts. Tighten the bracket-to-dash attaching bolts at this time.

10. Secure the cam latch to the shift tube with the attaching screws.

11. Secure the neutral safety switch to the shift tube. Connect the neutral safety switch wires and

100% SATISFACTION GUARANTEED

BUY IT NOW!

Click Here To Order

PayPal American Express Cards Discover Novus MasterCard VISA

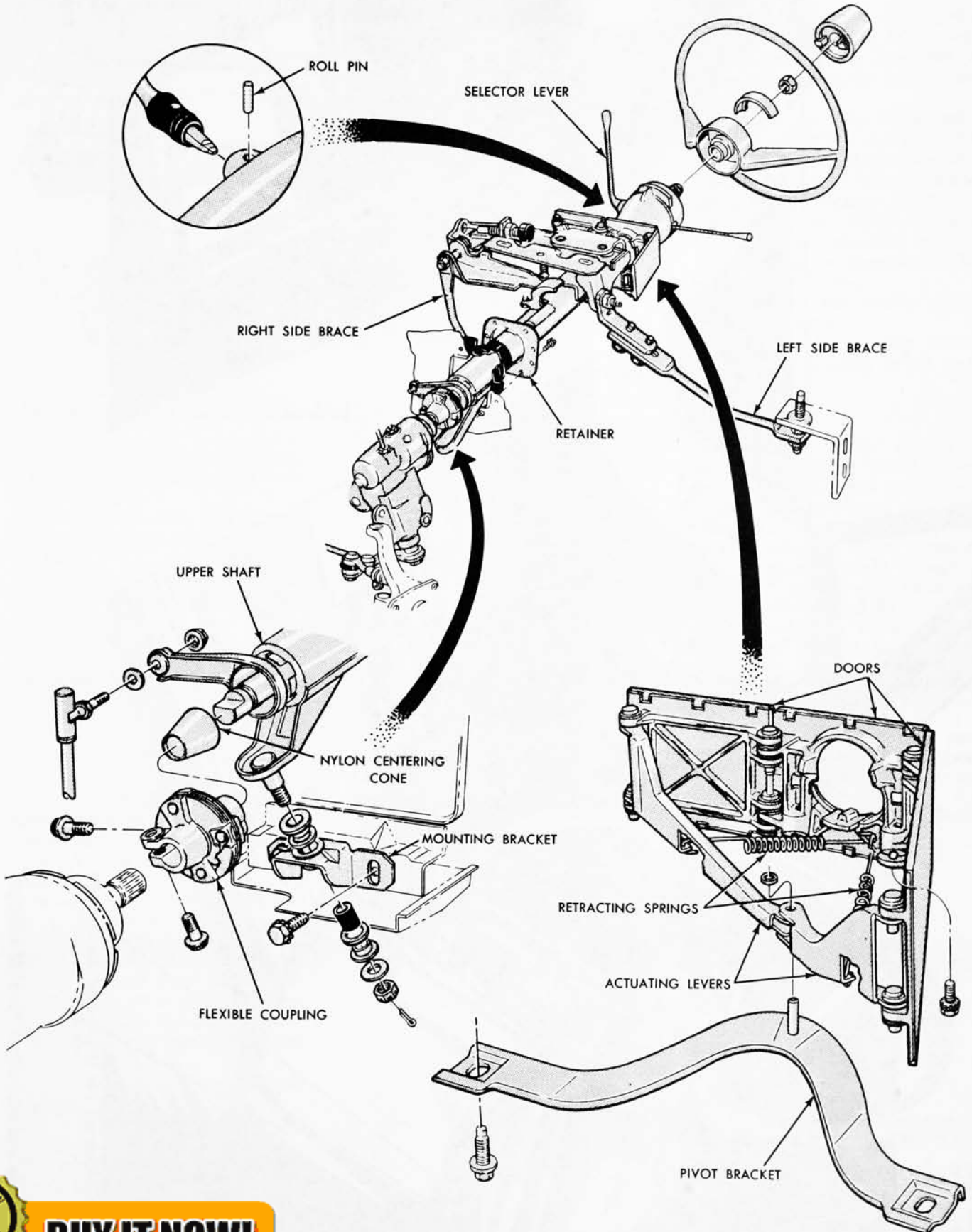

BUY IT NOW!

Click Here To Order

Installation



G1179-A

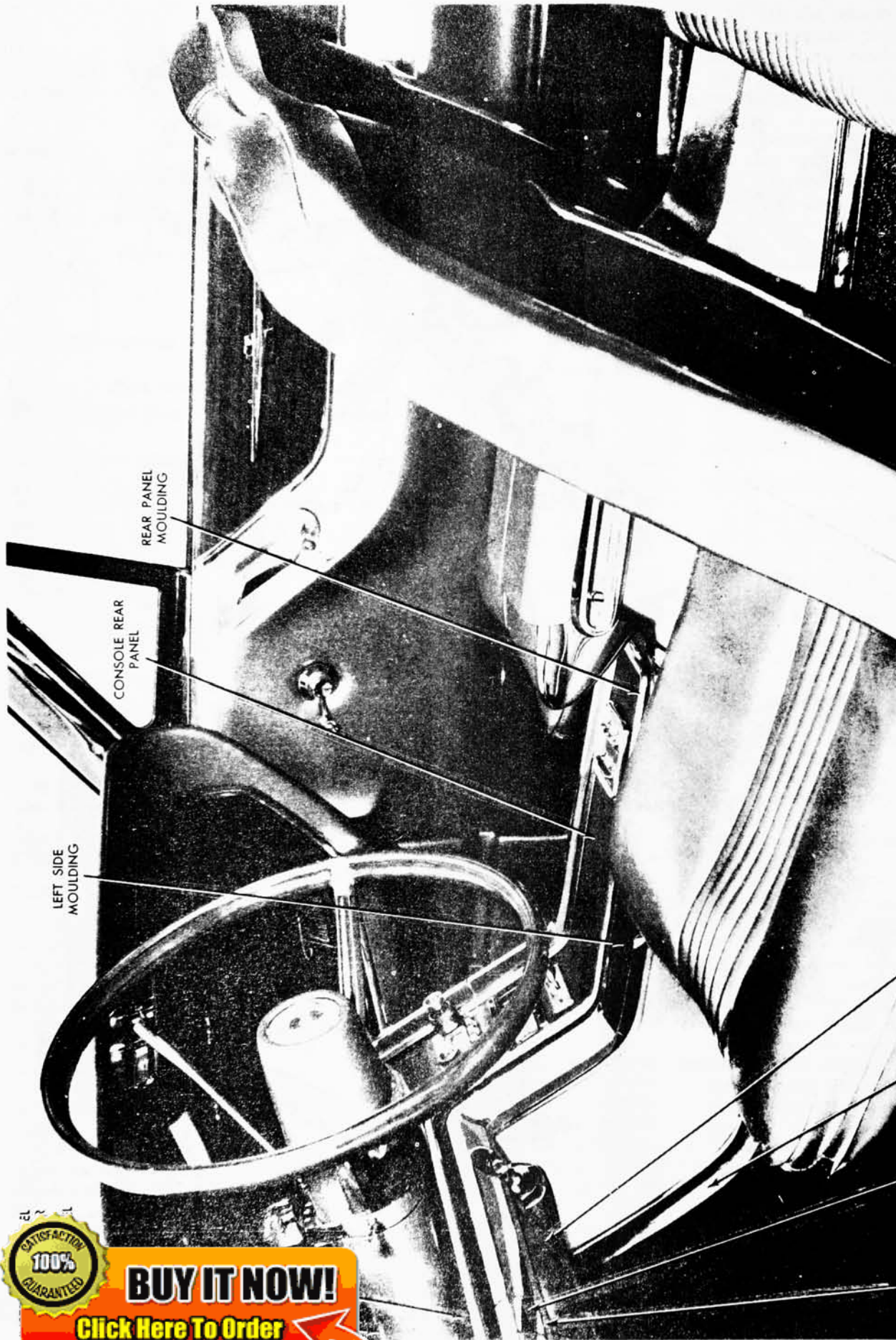

G1180-A

100% SATISFACTION GUARANTEED

BUY IT NOW!

Click Here To Order

FINISH PANEL MOULDING CAP LOWER EDGE EXTENSION

FIG. 9—Console and Instrument Panel Mouldings

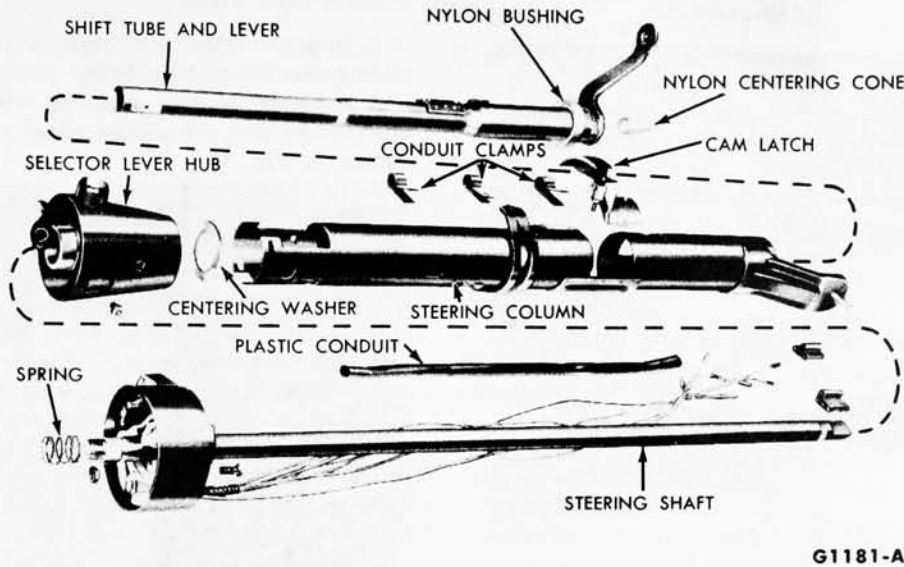

FIG. 10—Steering Column Disassembled

the two vacuum hoses to the switch.

12. Connect the turn signal wires at the connector.

13. Secure the dust boot and retainer to the dash with the attaching bolts.

14. Secure the column door pivot bracket to the lower end of the instrument panel.

15. Position the doors on the steering column tube and install the door lower half, but do not tighten the screws.

16. Secure the two door actuating levers to the pivot bracket with the pin, washers and the retainer.

17. Slide the doors to approximately $\frac{3}{16}$ inch from the instrument panel. Move the column to the side slowly and observe the operation of the door. It should be moved as close as possible to the instrument panel and still have clearance through the full movement. Tighten the two screws and install the two retracting springs (Fig. 8). The pivot bracket can be adjusted from side to side and fore and aft to make the doors parallel with the instrument panel.

18. Install the instrument panel finish panel.

19. Install the instrument panel moulding cover.

20. Install the headlamp switch on the instrument panel.

21. Install the radio access cover on the left side of the console and instrument panel.

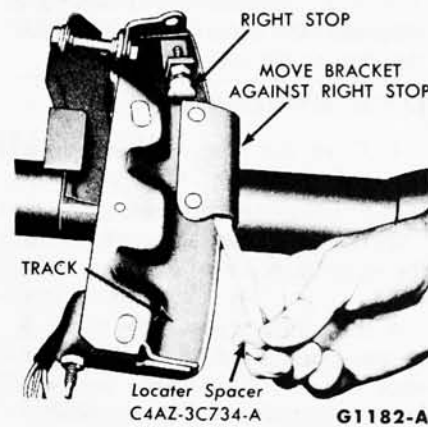

FIG. 11—Removing or Installing Locater Spacer

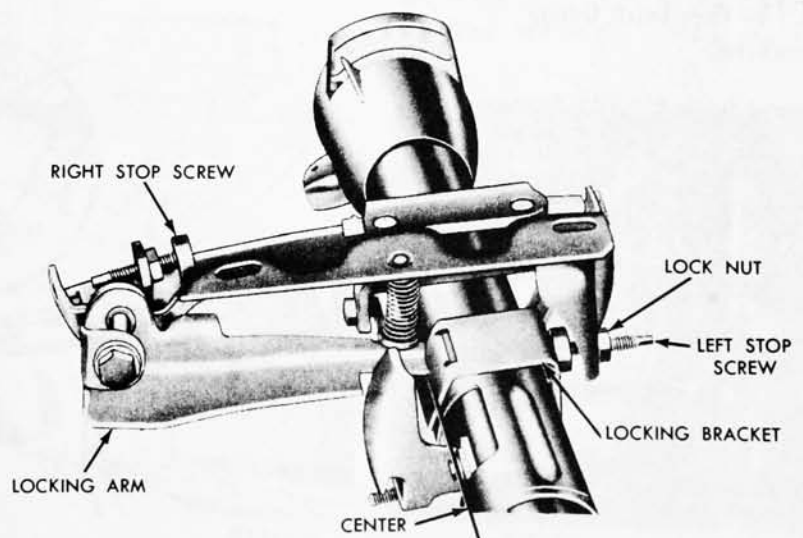

FIG. 12—Steering Column Stop Adjustments

finish panel extension and the moulding cap.

24. Place the upper steering shaft and the upper bearing in the steering column making sure that the lower end enters the flexible coupling.

25. Place the turn signal switch over the shaft and secure it with the retainer and attaching screws.

26. Install the upper bearing spring and the steering wheel.

27. Install the flexible coupling-to-steering shaft attaching bolt.

28. Connect the transmission shift rod to the shift lever.

29. Connect the battery ground cable to the battery.

30. Adjust the steering column and the neutral safety switch as required.

AIR BLEEDING

Air in the system (shown by bubbles in the fluid) should be bled. After making sure that the reservoir is filled to specification (the fluid must be at normal operating temperature when the check is made), turn the steering wheel through its full travel three or four times with the windshield wiper in operation. **Do not hold the wheels against their stops.** Recheck the fluid level.

MOVABLE COLUMN

STOP ADJUSTMENTS

1. Remove the instrument panel extension and the radio access panel.

2. Loosen the left stop screw lock nut.

100% SATISFACTION GUARANTEED

BUY IT NOW!

Click Here To Order

PayPal

Discover Cards

Discover Novus

MasterCard

VISA

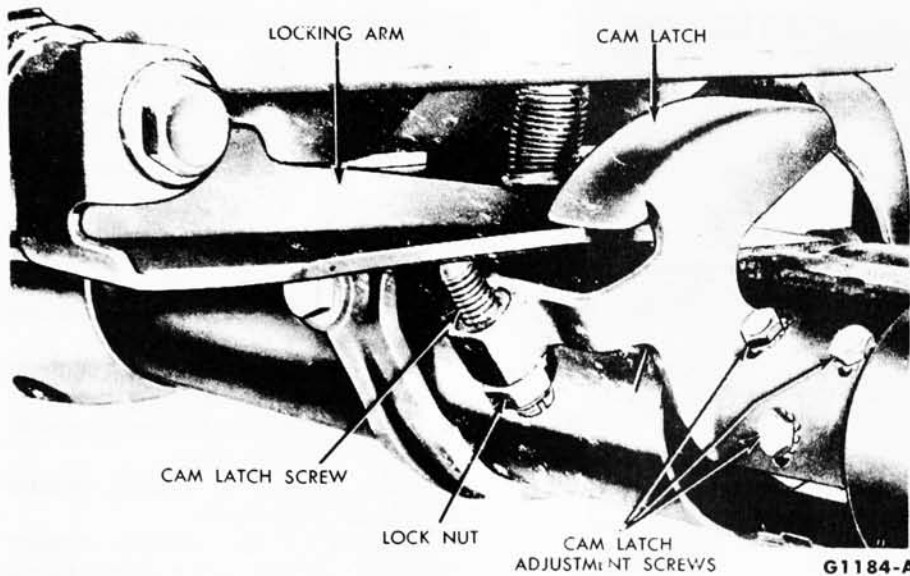

FIG. 13—Steering Column Locking Mechanism

3. Adjust the stop screw as required to center the locking arm on the locking bracket (Fig. 12).

4. Tighten the stop screw lock nut.

5. Move the column to the extreme right and observe for interference at the instrument panel, or air conditioner if so equipped.

6. If an interference is noted, loosen the lock nut on the stop screw at the right side of the track. Thread the screw inward as re-

quired to shorten the travel and eliminate the interference. Tighten the stop screw lock nut.

LOCK MECHANISM

1. Place the selector lever in the P (Park) position. Note the position of the locking arm.

2. If interference is noted, loosen the cam latch screw lock nut (Fig. 13).

3. Turn the screw (Fig. 13) in or out as required to provide clearance between the locking arm and bracket and also at the cam latch.

4. Tighten the cam latch screw lock nut.

5. If adjusting the cam latch screw does not correct the trouble, remove the column from the car and adjust the cam latch as shown in (Fig. 15).

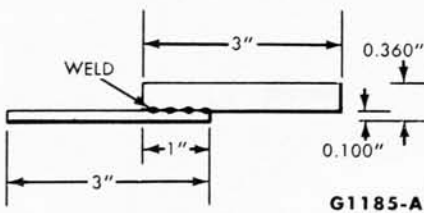

FIG. 14—Cam Latch Gauge (Fabricated)

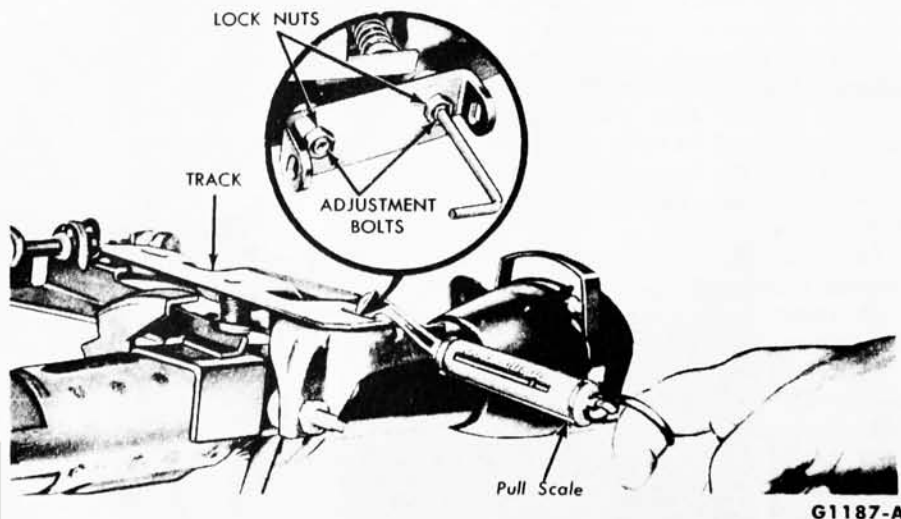
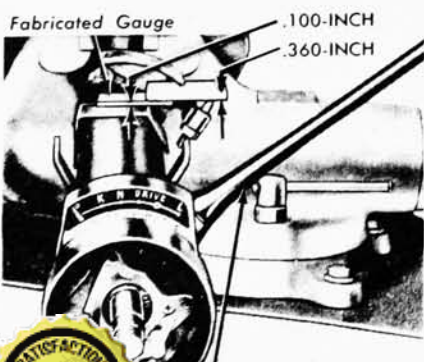

FIG. 16—Checking Track Sliding Effort

SLIDE FRICTION

1. Remove the two column-to-sliding track attaching bolts.

2. Connect a pull scale to the track and check the sliding effort as shown in Fig. 16.

3. To adjust the sliding effort, loosen the two lock nuts shown in Fig. 16. Tighten or loosen the two Allen head adjustment bolts as required to obtain a 10 lb. pull.

4. Tighten the two lock nuts. Recheck the pull effort.

5. Install the spacer shown in Fig. 11. Secure the column to the track with the two attaching bolts. Be careful when tightening the two column attaching bolts so as not to create a bind in the track.

6. Remove the nylon locating spacer from the track.

STEERING GEAR

WORM BEARING PRELOAD AND SECTOR MESH ADJUSTMENT

Worm Bearing Preload and Sector Mesh Adjustment

1. Remove the fluid from the power steering reservoir with a suction gun.

2. Disconnect the fluid return line from the reservoir. Place the end of the return line in a container and turn the steering wheel in both directions as required to discharge the fluid from the gear.

3. Working from under the car, disconnect the Pitman arm from the steering gear.

4. Remove the hub cap from the steering wheel.

5. Attach an in-lb torque wrench

100% SATISFACTION GUARANTEED

BUY IT NOW!

Click Here To Order

to the steering wheel attaching nut (Fig. 17).

6. Measure the force required to move approximately 20° away from the stop.

7. If reading is not within 6-8

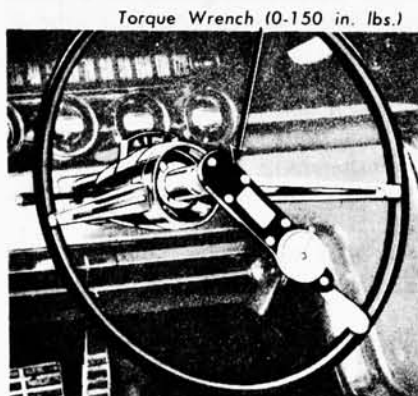

FIG. 17—Checking Steering Gear Pre-load

in-lbs loosen this adjuster lock nut and turn the bearing adjuster to obtain the proper reading.

8. Locate the mechanical center of the steering gear by rotating the steering wheel right or left to the stop then back it off 1¾ turns.

9. Rotate the steering gear to the left stop. Using an in-lb torque wrench, back it off at a constant pull, reading torque at exact mechanical center.

Rotate the gear to the right stop and take a reading in the opposite direction.

If two slightly different readings are obtained, the larger should be recorded as total on-center meshload.

10. If total over center meshload is not within 15-17 in-lbs, loose the sector adjuster lock nut (Fig. 18) and turn the adjuster screw to obtain proper adjustment.

NOTE: ¼ turn of the adjuster will

increase the meshload approximately 2 in-lbs.

Tighten the adjuster lock nut making sure the adjusting screw does not turn. Recheck the meshload.

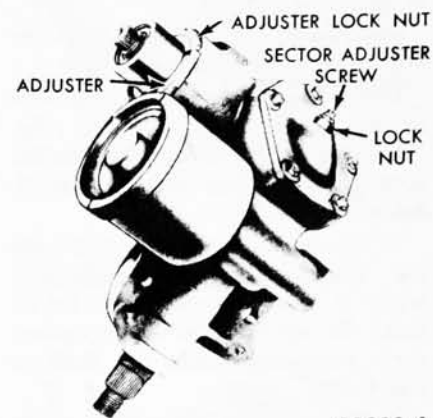

FIG. 18—Pre-load and Mesh Load Adjustments

3 REMOVAL AND INSTALLATION

STEERING GEAR

REMOVAL

1. Disconnect the pressure line and the return line from the steering gear housing. Plug the openings and cap the lines.

2. Disconnect the horn ground

wire from the sleeve alignment bolt. Remove the bolt that secures the flexible coupling to the steering gear worm shaft (Fig. 19).

3. Raise the car and disconnect the Pitman arm from the sector shaft (Fig. 20).

4. Remove the steering gear-to-

body member mounting bolts (Fig. 21), and pull the steering gear from the flexible coupling.

INSTALLATION

1. If a new gear is being installed, transfer the insulators (Fig. 21) from the old gear to the new one if they are in a serviceable condition.

2. Center the gear by turning the worm shaft to either stop, then, turn it back approximately two turns.

3. Center the steering wheel and insert the input shaft in the flexible coupling. Secure the steering gear to

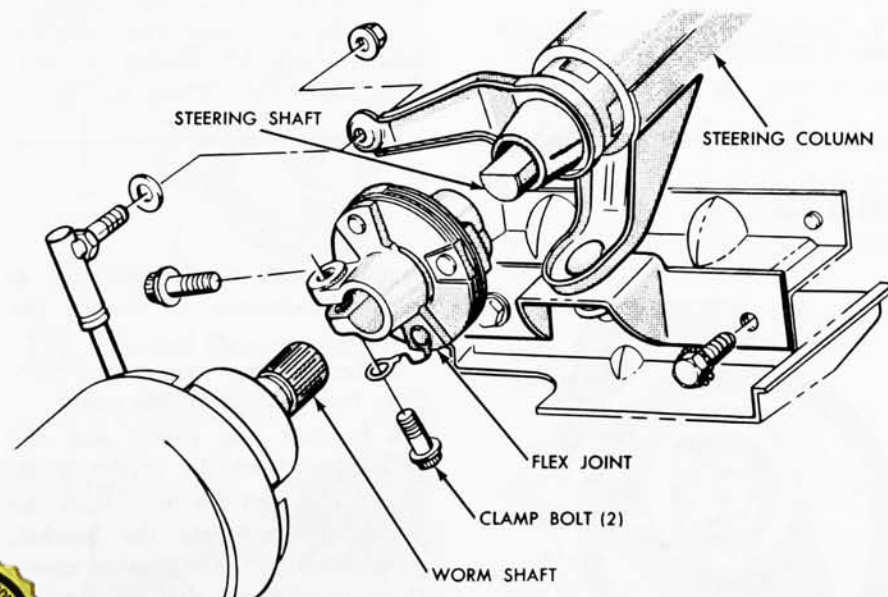

G1165-B

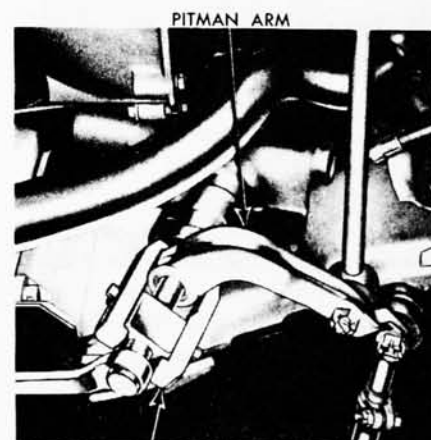

Tool—3590-FC

G1090-B

FIG. 20—Removing Pitman Arm

100% SATISFACTION GUARANTEED

BUY IT NOW!

Click Here To Order

PayPal American Express Discover Novus MasterCard VISA

Steering Column and Pitman Arm-to-Steering Gear Connections

the body member with the attaching bolts. Torque the bolts to specifications.

4. Position the Pitman arm on the sector shaft and secure it with a lock washer and nut. Torque the nut to specifications.

5. Connect the pressure and the return line to the steering gear.

6. Connect the horn ground wire to the sleeve alignment bolt (Fig. 1). Install and torque the flexible coupling attaching bolt to specifications.

7. Fill the fluid reservoir and cycle the steering with the windshield wiper in operation and check for oil leaks. Do not hold the wheels against their stops and cause the fluid to overheat.

8. If the gear has been overhauled, adjust the position of the valve spool as detailed in "Assembly of Steering Gear".

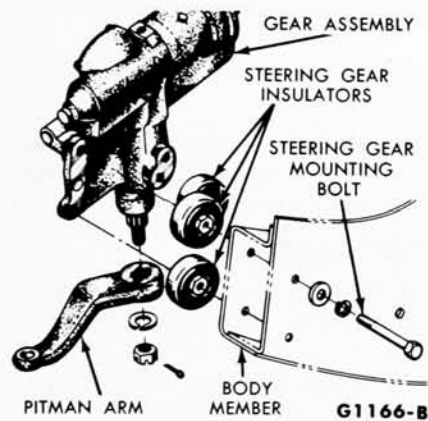

FIG. 21—Steering Gear Mountings

POWER STEERING PUMP

On a car without air conditioning, the reservoir is mounted on the pump. On a car with air conditioning, the reservoir is mounted on the left fender apron.

PUMP AND FLUID RESERVOIR REMOVAL

1. Remove the pump cover if not equipped with a dipstick. With a suction gun, remove as much fluid as possible from the reservoir.

2. Disconnect the hoses at the pump, and fasten them in a raised position to prevent fluid from draining out.

3. Loosen and remove the pump belt.

4. Remove the pivot bolt and the adjusting bolt, and lift out the pump, reservoir, and bracket or pump bracket or adapter on vehicles equipped with air conditioning.

INSTALLATION

1. Position the pump, reservoir and bracket or pump bracket and adapter in the engine compartment, and install the mounting bolts finger-tight.

2. Position the pump belt, and check the alignment of the crankshaft and pump pulleys. If the pulleys are not aligned, the pump may be incorrectly installed, or spacers may be necessary.

3. Adjust the belt tension (Part 3-5).

4. Connect the two hoses at the pump.

5. Position the filter seat in the

reservoir making sure that it is properly indexed over the oil-return tube.

6. Position the filter on the seat. Place the filter hold-down washer and the spring on the filter.

7. Fill the reservoir with automatic transmission fluid to a point one inch from the top or to the F mark on the dipstick. Do not overfill.

Install the non-dipstick type cover at this time. **The cover must be seated evenly and tightly around the edge of the reservoir. Tighten the wing nut securely.**

8. Start the engine and run it at idle speed for about two minutes to warm the fluid in the power steering system.

9. After turning the steering wheel all the way to the left and right several times with the windshield wiper in operation, check the system for leaks.

10. Increase the engine speed to about 1000 rpm, and turn the steering wheel all the way to the left and right several times while continuing to operate the windshield wiper.

11. Stop the engine, and check the pump, reservoir, and hose connections for fluid leaks. Correct the cause of any leaks.

12. Check the fluid level, and refill the reservoir if necessary.

To check the fluid level in the remote mounted reservoir, turn the wing nut to the top of the stud, then rotate the cover clockwise until the fluid is visible. Add fluid as required, then replace the cover.

4 MAJOR REPAIR OPERATIONS

POWER STEERING PUMP DISASSEMBLY

Handle all parts very carefully to avoid nicks, burrs, scratches, and dirt which could make the parts unfit for use.

1. Drain as much as possible of the remaining fluid from the pump and reservoir, and clamp the pump adjusting bracket in a vise.

On a car without air condi-

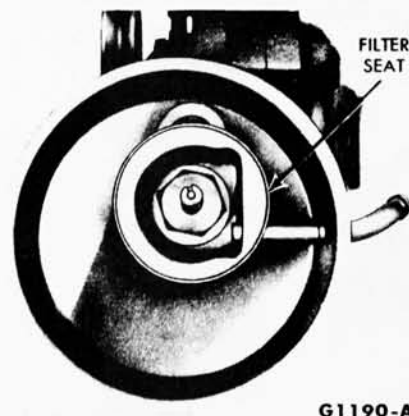

FIG. 22—Fluid Reservoir

equipped with air conditioning, it may be necessary to remove the adapter.

3. Remove the two orifice "O"-rings from the top of the pump.

4. Remove the pulley and the pulley key from the carrier shaft.

5. Remove all the bolts from the pump, and separate the bracket, pump housing, and housing cover. If the parts do not pull apart easily, tap them gently with a soft-faced hammer to loosen them. **Lift the cover vertically from the housing to prevent internal parts from falling out.**

100% SATISFACTION GUARANTEED

BUY IT NOW!

[Click Here To Order](#)

PayPal, American Express, Discover, MasterCard, VISA

6. Remove the "O"-rings from the flow director and the carrier insert (Fig. 23).

7. Using a feeler gauge and a straight-edge, check the end clearance of the carrier and the rollers in the pump housing (Fig. 24). If the clearance exceeds 0.0015 inch, replace the worn parts. A damaged roller carrier, or insert should not be replaced by itself. These parts are serviced in a kit, and all parts of the kit should be used.

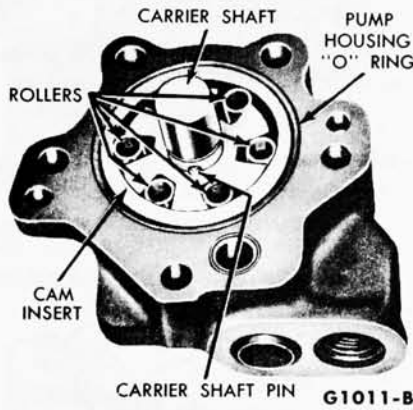

FIG. 23—Pump Housing Carrier and Shaft

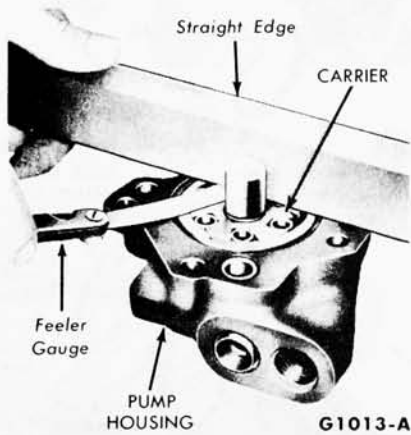
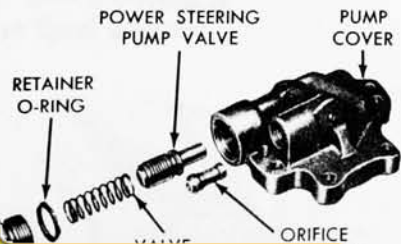

FIG. 24—End Clearance Check



BUY IT NOW!

Click Here To Order

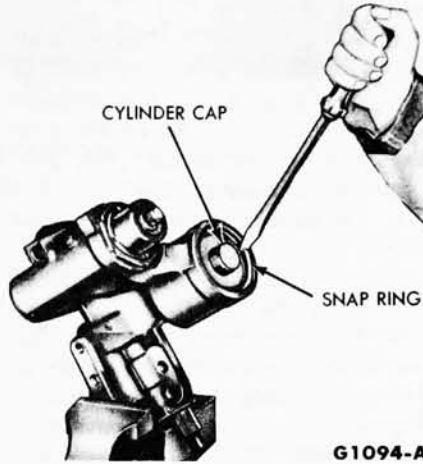

FIG. 26—Removing Cylinder Cap Snap Ring

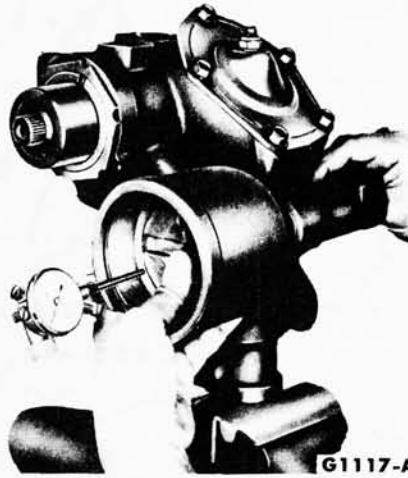

FIG. 27—Checking Piston Backlash

8. Remove the six rollers, and then pull out the carrier and shaft very carefully to avoid damage to these parts or the oil seal. Remove the cam insert only for replacement.

9. Slide the carrier off the shaft and remove the carrier shaft pin (Fig. 23).

10. Remove the relief valve retainer (Fig. 25) from the housing cover, and remove the "O"-ring from the retainer.

11. Remove the valve spring from the bore in the housing cover, and slide the valve out of the bore. If the valve does not slide out easily, tap the cover with a soft-faced hammer. Do not scratch or nick the valve when removing it from the cover.



FIG. 28—Checking Pre-Load



FIG. 29—Removing Sector Shaft



FIG. 30—Removing Piston O-Ring

STEERING GEAR DISASSEMBLY

Use only parts specified for the Thunderbird steering gear.

1. Drain the hydraulic fluid from the ports, and thoroughly clean the exterior of the unit with a suitable solvent.

10. Remove the valve adjuster cap and remove the "O"-ring from the cap.

11. Remove the bearing adjuster lock nut and the bearing adjuster.

12. Remove the torsion bar and sleeve assembly (Fig. 32), by lightly tapping on the lower end of the torsion bar with a soft-faced hammer.

13. Remove the sector shaft oil seal retaining snap ring (Fig. 31).

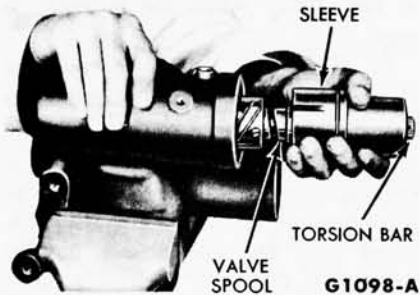

FIG. 32—Removing Torsion Bar and Sleeve

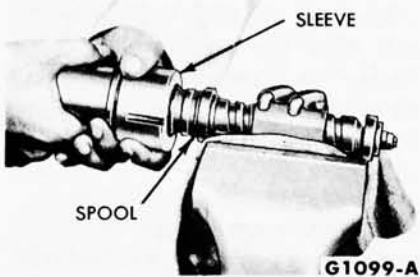

FIG. 33—Removing Valve Spool Sleeve

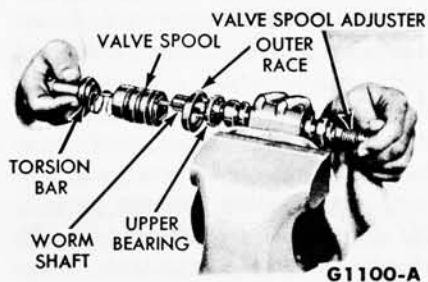

FIG. 34—Removing Valve Spool Adjuster



Remove the outer seal with tool 1175-AE, then remove the spacer. Remove the inner seal with tool 1175-AE.

TORSION BAR AND SLEEVE DISASSEMBLY

1. Position the ball nut assembly in a vise. Use a clean cloth in the vise to protect the ball nut assembly. Remove the valve spool sleeve from the torsion bar assembly (Fig. 33). Remove the "O" ring from the sleeve.

2. Remove the valve spool adjuster lock nut from the lower end of the torsion bar. Remove the valve spool adjuster from the torsion bar.

3. Remove the torsion bar, valve spool, actuator, seal, bearing and race from the worm shaft (Fig. 34). Tap the end of the torsion bar with a soft-faced hammer, if necessary. **The valve spool and the actuator assembly are spring-loaded.** Discard the lower bearing race seal. Separate the valve spool and the actuator assembly from the torsion bar by turning the valve spool and actuator while turning the torsion bar.

4. Remove the valve spool snap ring. Remove the valve spool from the actuator.

5. Check the ball nut assembly for evidence of binding or rough spots in the assembly itself. **Do not disassemble unless there is evidence of binding or rough spots. Be sure, however, that there is sufficient lubrication throughout the ball nut. The ball nut is not preloaded and should move freely throughout the entire travel. Do not rotate the ball nut against the end of the worm shaft as damage will result. To disassemble the ball nut proceed as follows:**

6. Remove the ball nut guide retainer and the ball guides. Turn the nut over and remove the balls by rotating the worm shaft from side to side. Catch the balls in a clean pan or a clean cloth. Remove the ball nut from the worm shaft. **Note the position of the ball nut on the worm shaft (Fig. 35).**

7. Wash all parts in clean solvent and dry them with compressed air.

8. Inspect the worm and ball nut grooves, and all of the balls for

wear or scoring. If either the worm or ball nut needs replacing, both must be replaced as a matched assembly. Inspect the ball nut teeth for pitting, wear or scoring.

9. Make certain that the ball return guide ends are not damaged.

PARTS REPAIR AND REPLACEMENT

PUMP ORIFICE TUBE SEAT REPLACEMENT

If damage, wear, or leakage makes replacement of this seat necessary, use the following procedure:

1. Tap the existing hole in the seat, using a starting tap of suitable size. **Be sure to remove all metal chips from the seat port after tapping.**

2. Place a nut and large flat washer on a bolt of the same size as the tapped hole. The washer must be large enough to cover the seat port.

3. Insert the bolt in the tapped hole and, using it as a puller, remove the seat.

4. Place a new seat in the port, and thread a bolt of suitable size into the port. Tighten the bolt enough to bottom the seat in the port.

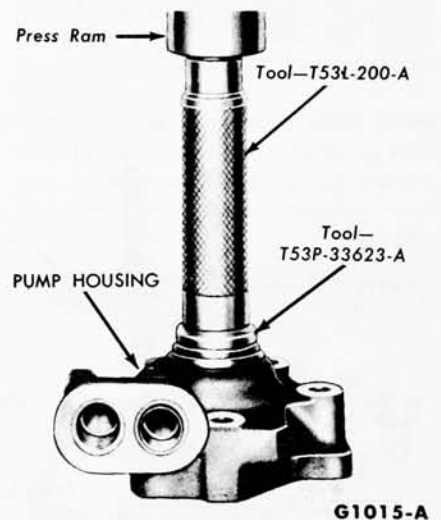

FIG. 36—Installing Shaft Seal

CARRIER SHAFT SEAL REPLACEMENT

If the shaft seal was removed from the pump housing, install a new seal. **Do not install the old seal.**

100% SATISFACTION GUARANTEED

BUY IT NOW!

Click Here To Order

PayPal, American Express, Discover, MasterCard, VISA

1. Coat the lip of a new seal with Lubriplate or equivalent.
2. Position the seal in the bore of the housing. **The lip of the seal must face toward the pump housing carrier chamber.**
3. Press the seal into the housing (Fig. 36), until it seats firmly and evenly against the shoulder in the bore.

STEERING GEAR HOUSING

Clean the housing thoroughly, using clean solvent. Blow out all passages.

1. Inspect the housing for cracks and stripped threads, and mating surfaces for burrs.
2. Check the fluid passages for obstruction or leakage.
3. Inspect the housing piston bore. If scored or worn, replace the housing.
4. Check the sector shaft bushings in the housing for wear. If worn, replace the housing.
5. Check tube seats, in the pressure and return ports, for nicks, etc. and replace if required.
6. Install a new "O"-ring (not reusable) in the housing inlet port.

ASSEMBLY

PUMP ASSEMBLY

Before assembling the pump and reservoir, coat all parts with auto-

matic transmission fluid. **If the cam insert is to be replaced, the new insert must be installed so that the slot in the edge of the insert engages the small pin in the pump housing.**

1. If the carrier and related parts seem to be in good condition, install the pin and the carrier on the shaft. Make sure that the carrier teeth are pointed in a counterclockwise direction when the carrier is installed in the housing.

2. Carefully insert the shaft through the housing, taking care not to damage the seal. Install the rollers. **To avoid damage to the seal, be sure the shaft does not move back and forth in the housing.**

3. Position the valve assembly and spring in the bore, install a new "O"-ring on the pump valve retainer, and install the retainer in the pump housing cover. Torque the retainer to specifications.

4. Place a new "O"-ring in the groove around the insert in the pump housing, and install a new flow "O"-ring in the face of the housing (Fig. 23).

5. Fasten the pump housing and cover together.

6. Clamp the adjusting bracket in a vise, and install the pump on the bracket. Torque all bolts to specifications.

7. Install the key, pulley washer, and retaining bolt on the carrier shaft.

8. Torque the pulley retaining bolt to specification. **The carrier shaft should turn freely when the bolt is properly tightened.**

9. Place the new "O"-rings in the grooves on the top of the pump housing on pump mounted reservoirs. Only one "O"-ring is required at the outlet when the adapter is used.

10. Hold the reservoir on the pump housing, and install the reinforcement in the reservoir. Install and torque the retaining bolt to specifications. **The ears on the reinforcement should be facing upward over the outer hole in the reservoir.** On cars equipped with air conditioning, properly position the adapter. Then, install and torque the retaining bolt to specifications.

11. Cement a new cover gasket around the inside of the cover. Install only the dipstick-type cover, washer, and retaining bolt at this time. **The cover must be seated evenly and tightly on the reservoir.**

TORSION BAR AND SLEEVE ASSEMBLY

1. Slide the ball nut over the worm. See Fig. 35 for the correct position. Align the ball return guide holes with the worm groove. Count 31 balls (one half the number of balls) into a suitable container. This is the number of balls required to fill one circuit. Drop 21 of these balls into one guide hole to fill the one circuit in the ball nut. It may be necessary to oscillate the shaft slightly to circulate the balls. Make sure that none of the balls come out the other end of the circuit and enter the worm groove between the two circuits.

2. Coat the groove of one-half of a return guide with clean oil-soluble grease and place 10 balls in the guide. Place the other half of the guide over the balls. While holding the two halves together, push the guide into the guide holes in the ball nut. If the guide does not push all the way down easily, tap it lightly with a soft-faced hammer to seat it.

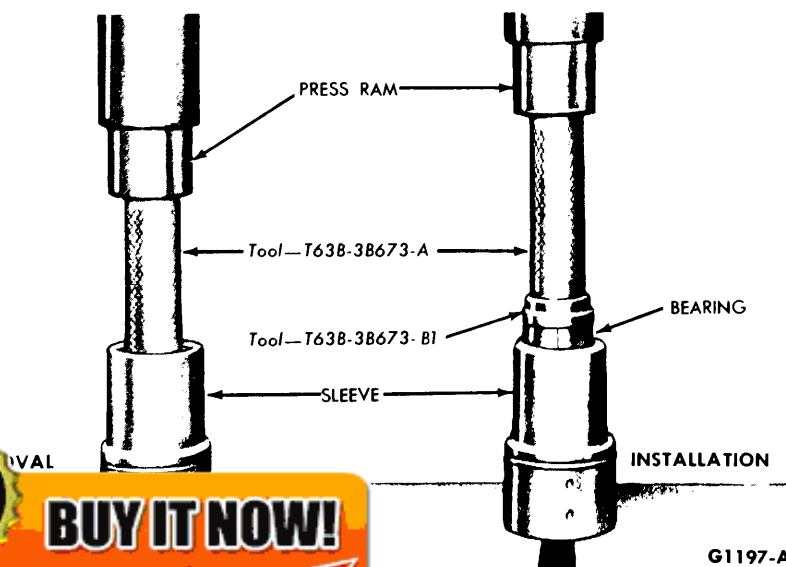

G1197-A

100% SATISFACTION GUARANTEED

BUY IT NOW!

Click Here To Order

Fig. 35. Rebuilding sleeve ball nut. 19

PayPal American Express Discover Novus MasterCard VISA

Fill the second circuit in the same manner and then attach the guide clamp with the lock washers and retaining screws.

3. Inspect the torsion bar splines for nicks, pitting, wear or scoring. Make sure the blind spline on the torsion bar lines up with the punch dot on the upper end of the assembly (large splined end). If they do not line up, replace the torsion bar assembly.

4. Check the fit of the actuator on the torsion bar assembly, with the spring in place. Hold the torsion bar while turning the actuator. When the actuator is released, the spring should cause the actuator to pop off the threads. If it does not pop off, replace the spring and check the gear teeth for burrs. If there are any burrs that cannot be removed, replace the defective parts.

5. Check the sleeve ball bearing for freedom of rotation. If the bearing is satisfactory, remove the snap ring and replace the oil seal. If the bearing must be replaced, remove the seal, and then remove the bearing, using the tool shown in Fig. 37.

6. Install the bearing in the sleeve, using the tools shown in Fig. 37. **The bearing must be pressed in so that there is 0.035-0.045 inch between the upper surface of the bearing and the seal seat surface of the sleeve.** To install the seal, use the tool shown in Fig. 37. Install the snap ring and check bearing rotation.

7. Lubricate the parts with automatic transmission fluid.

8. Check the fit of the upper bearing race to insure that it is a slip fit in the sleeve. Install the bearing race and bearing on the worm shaft.

9. Install the valve spool on the actuator and retain with a new snap ring. Check the valve spool for free rotation.

10. Install the torsion bar spring and the actuator on the torsion bar. Turn the lower end of the shaft so

that the two identifying punch marks

aligned (Fig. 38). Hold the

the aft, the

the spiral

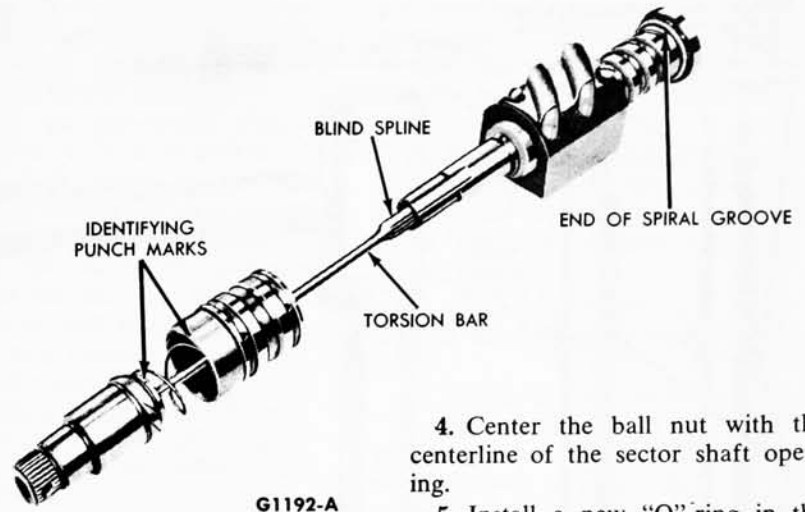

G1192-A

FIG. 38—Installing Torsion Bar

worm and shaft. **The torsion bar assembly is properly installed when the valve spool bottoms against the upper bearing and race.**

11. Hold the lower bearing, race and seal in position on the worm shaft and install the valve spool adjuster on the torsion bar, but do not tighten. Install the lock nut. Lubricate the lip of the input shaft seal with automatic transmission fluid.

12. Install the valve sleeve over the valve spool so that the upper bearing outer race is seated in the recess of the sleeve. Install a new "O"-ring seal on the sleeve.

ASSEMBLY OF STEERING GEAR

Refer to Fig. 31.

1. Align the slot in the sleeve with the lock screw in the housing, and install the torsion bar and sleeve assembly in the housing. **Be sure that the seal and the lower bearing outer race are properly seated.** Tap on the sleeve until it bottoms. Torque the lock screw to 15-20 ft-lbs. **The lock screw and the brass washer must be seated against the housing when they are properly installed.**

2. Install the bearing adjuster and lock nut.

3. Install the valve spool centering wrench (Fig. 39) on the valve spool adjuster, and locate the valve spool so that the valley between the lands can be seen through the pressure port. Lock the adjuster with the lock nut. **This is only a preliminary adjustment.**

4. Center the ball nut with the centerline of the sector shaft opening.

5. Install a new "O"-ring in the piston rack bore of the housing, and lubricate the parts.

6. Carefully hone the edges of the piston rack teeth with a hand stone to prevent cutting the piston rack bore "O"-ring during installation.

7. Install a new "O"-ring on the piston and install the piston in the housing. **Lubricate the parts thoroughly, and rotate the piston while inserting it.** Align the center rack teeth with the sector bore in the housing.

8. Grease the sector shaft splines and install the shaft. Make sure that the sector shaft is centered by rotating the worm shaft. Count the turns from one stop to the other. There should be a least 3½ turns. If there are fewer than 3½ turns, remove the sector shaft and install correctly.

9. Position the sector shaft inner seal in the steering gear housing with the rubber sealing lip facing inward. Seat the seal in the housing with tool T61B-3576-A and adapter

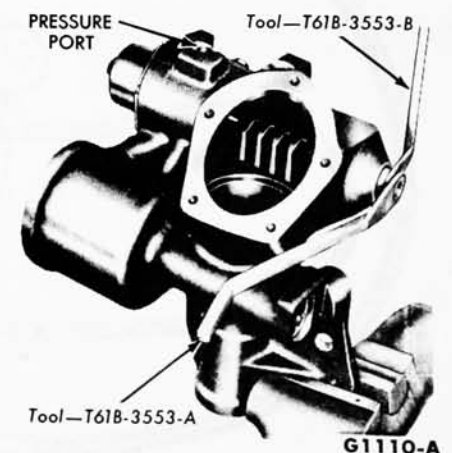

G1110-A

FIG. 39—Valve Spool Preliminary Centering



BUY IT NOW!

Click Here To Order



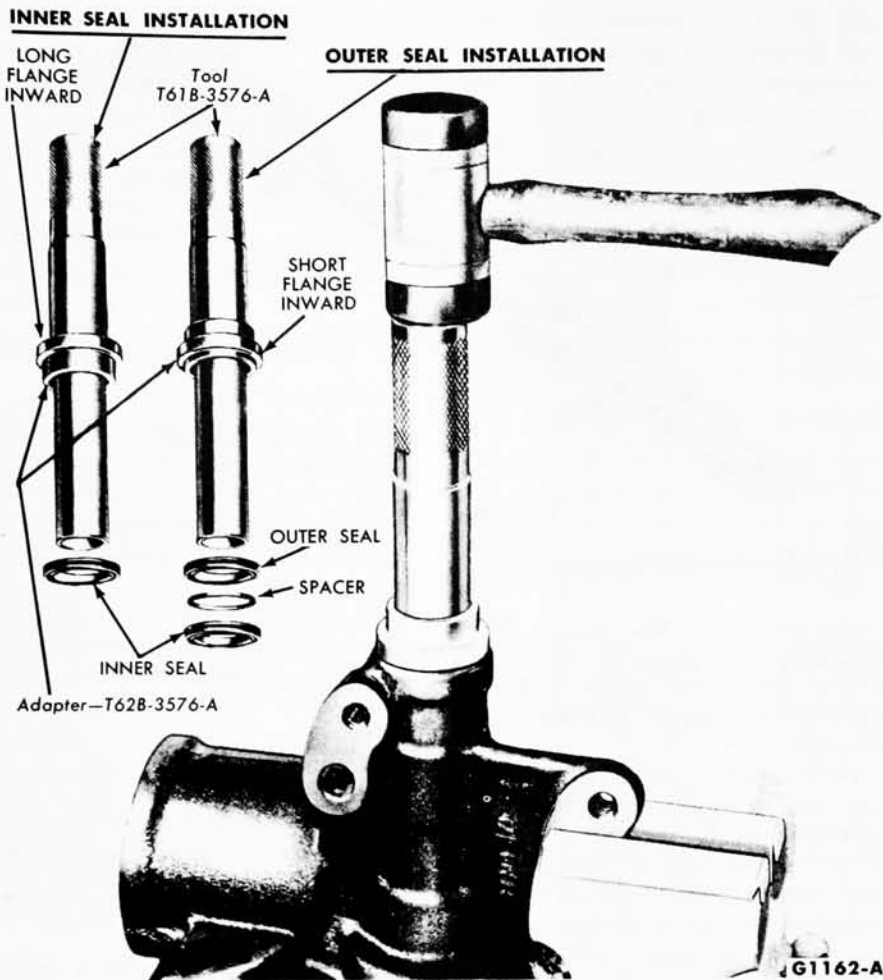

FIG. 40—Installing Sector Shaft Oil Seals

T62B-3576-A as shown in Fig. 40. The long flange of the adapter should press against the seal.

10. Install the metal spacer against

the inner seal, then position the sector shaft outer seal with the sealing lip facing inward against the spacer. Seat the seal with the tool and

adapter (Fig. 40). The short flange of the adapter should press against the outer seal.

11. Install the seal retaining snap ring. If the outer seal has blocked off the snap ring retaining groove in the casting, tap the tool and adapter against the snap ring so that the snap ring will seat into the groove of the casting.

12. Install the sector shaft adjusting screw with the proper shim. Place the housing cover, with a new gasket in place, over the adjusting screw, and turn the screw until the cover is seated. Install new cover attaching screws, and torque them to specification.

13. Adjust the worm bearing preload and the sector mesh as described in Section 2. This adjustment can be accomplished with the steering gear out of the car by attaching a 3/4-inch socket (12 point) and in-lb torque wrench to the input shaft instead of the steering wheel attaching nut.

14. To adjust the centering spool, connect a 2000 psi pressure gauge between the car pump pressure line and the inlet port (upper hole) in the gear (Fig. 41).

15. Connect the return hose to the outlet port (lower hole) in the gear.

16. Make certain that the gauge hand valve is in the fully open position.

17. Fill the power steering pump reservoir to the correct level with the specified fluid.

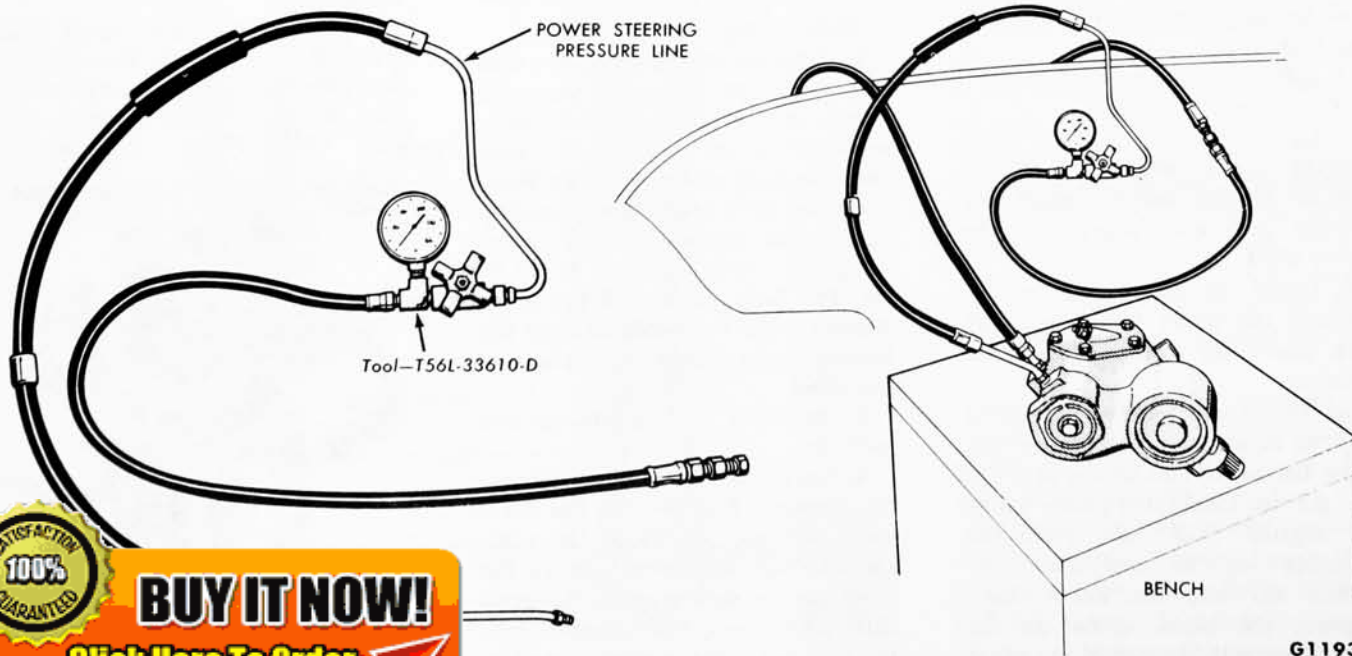

BUY IT NOW!

Click Here To Order



G1193-A

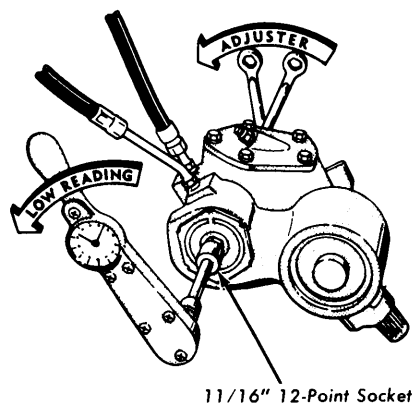

1 1/16" 12-Point Socket

G1194-A

**FIG. 42—Adjusting
Centering Spool**

18. Start the engine and cycle the steering gear from stop-to-stop until the fluid is hot. Recheck the reservoir and add fluid if necessary.

19. Using an inch-pound torque wrench with a $\frac{3}{4}$ -inch socket at the input shaft, rotate the gear to the left stop, adding sufficient torque to the torque wrench simultaneously to obtain 300 psi on the pressure gauge, and the required torque on the torque wrench gauge.

Repeat this process again in the opposite direction.

The torque required to obtain a gauge reading of 300 psi in both directions should not differ more than 3 in-lbs.

20. If the torque wrench reading is more than 3 in-lbs between the right and left turns, loosen the valve spool adjuster lock nut and rotate the adjuster in the direction of the

low reading (Fig. 42). Only a slight movement of the adjuster is required to move the valve spool. Tighten the adjuster lock nut before each reading is made.

21. Recheck the torque in both directions as in step No. 19. If the readings are within 3 in-lbs of each other, install the adjuster cap. Disconnect hoses.

22. Check the piston rack backlash as detailed under DISASSEMBLY.

23. Install a new cylinder plug "O"-ring and the cylinder plug in the piston rack bore. Secure the cylinder plug with a snap ring.

24. Install a new cylinder cap "O"-ring in the piston bore, then install the cylinder cap and snap ring.

25. Install the steering gear in the car.

100% SATISFACTION GUARANTEED

BUY IT NOW!

Click Here To Order

PayPal | American Express | Discover | MasterCard | VISA

PART 3-4 WHEELS AND TIRES

Section	Page	Section	Page
1 Description and Operation	3-32	3 Removal and Installation	3-33
2 In-Car Adjustments and Repairs	3-32	4 Major Repair Operations	3-33

1 DESCRIPTION AND OPERATION

FRONT WHEEL ASSEMBLY

Each front wheel and tire assembly is bolted to its respective front hub and brake drum assembly. Two opposed tapered roller bearings are installed in each hub. A grease retainer is installed at the inner end of the hub to prevent lubricant from leaking into the drum. The entire assembly is retained to its spindle

by the adjusting nut, nut lock and cotter pin (Fig. 1). The front wheel assemblies rotate freely on their respective spindles and are driven by the motion of the car.

REAR WHEEL ASSEMBLY

The rear wheel hub and brake drum assembly is retained on studs on the rear axle shaft flange by three speed nuts (Part 3-2, Fig. 2). The

wheel and tire assembly mounts on the same rear axle shaft flange studs and is held against the hub and drum by the wheel nuts. The rear wheel bearing is pressed onto the axle shaft just inside the shaft flange, and the entire assembly is retained on the rear axle housing by the bearing retainer plate which is bolted to the housing flange.

2 IN-CAR ADJUSTMENTS AND REPAIRS

FRONT WHEEL BEARING ADJUSTMENT

The front wheel bearings should be adjusted if the wheel is loose on

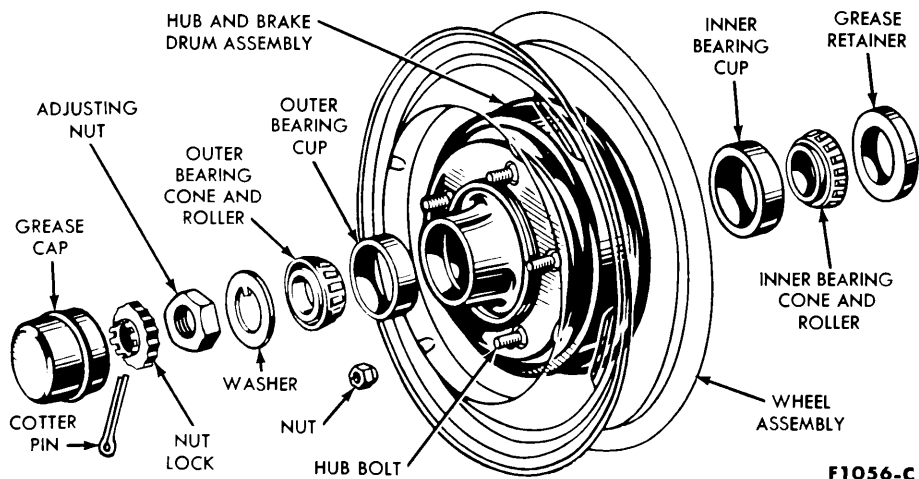
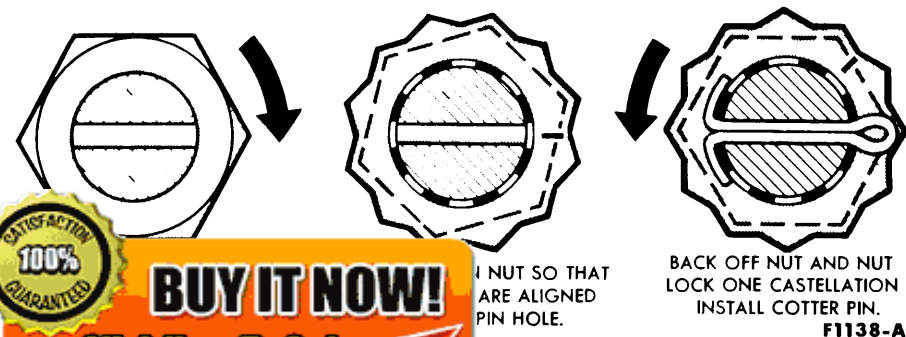

FIG. 1—Front Hub, Bearings and Grease Retainer



the spindle or if the wheel does not rotate freely. The following procedure will bring the end play to specification.

1. Raise the car until the wheel and tire clear the floor.
2. Pry off the wheel cover and remove the grease cap (Fig. 1) from the hub.
3. Wipe the excess grease from the end of the spindle, and remove the adjusting nut cotter pin and nut lock.
4. While rotating the wheel, hub, and drum assembly, torque the adjusting nut to 15-20 ft-lbs to seat the bearings (Fig. 2).
5. Locate the nut lock on the adjusting nut so that the castellations on the lock are aligned with the cotter pin hole in the spindle.
6. Using a 1½-inch box wrench, back off both the adjusting nut and the nut lock together until the next castellation on the nut lock aligns

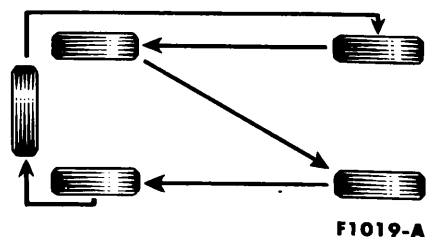

FIG. 3—Tire Cross-Switching Diagram

100% SATISFACTION GUARANTEED

BUY IT NOW!

[Click Here To Order](#)

PayPal, American Express, Discover, MasterCard, VISA

with the cotter pin hole in the spindle.

7. Install a new cotter pin, and bend the ends of the cotter pin around the castellated flange of the nut lock.

8. Check the front wheel rotation.

If the wheel rotates properly, install the grease cap and the hub cap or wheel cover. If the wheel still rotates roughly or noisily, clean or replace the bearings and cups as required.

3 REMOVAL AND INSTALLATION

WHEEL AND TIRE ASSEMBLY

REMOVAL

1. Pry off the wheel hub cap or cover. Loosen but do not remove the wheel hub nuts.

2. Raise the car until the wheel and tire clear the floor.

3. Remove the wheel hub nuts from the bolts, and pull the wheel and tire assembly from the hub and drum.

DEMOUNTING TIRE FROM WHEEL

The tire can be demounted on a mounting machine. **Be sure that the outer side of the wheel is positioned downward.** If tire irons are used, follow the procedure given here.

1. Remove the valve cap and core, and deflate the tire completely.

2. With a bead loosening tool, break loose the tire side walls from the wheel (Fig. 4).

3. Position the outer side of the wheel downward, and insert two tire irons about 8 inches apart be-



F1058-A

FIG. 4—Bead Loosening Tool

tween the tire inner bead and the back side of the wheel rim. **Use only tire irons with rounded edges or irons designed for demounting tubeless tires.**

4. Leave one tire iron in position, and pry the rest of the bead over the rim with the other iron. Take small "bites" with the iron around the tire in order to avoid damaging the sealing surface of the tire bead.

5. Stand the wheel and tire upright with the tire outer bead in the drop center well at the bottom of the wheel. Insert the tire iron between the bead and the edge of the wheel rim, and pry the wheel out of the tire.

MOUNTING TIRE TO WHEEL

1. If a used tire is being installed remove all dirt from the tire.

If a tire is being mounted on the original wheel, clean the rim with emery cloth or fine steel wool. Check the rim for dents.

If a new wheel is being installed, coat a new valve with RUGLYDE or similar rubber lubricant and position the valve in the new wheel. Use a rubber hammer or a valve replacing tool to seat the valve firmly against the inside of the rim.

2. Apply RUGLYDE or a similar rubber lubricant to the sealing surface on both tire beads. With the outer side of the wheel down, pry the beads over the wheel rim with two tire irons. **Do not use a hammer or mallet to force the beads over the rim.**

3. Align the balance mark on the tire with the valve on the wheel.

4. Hold the beads against the rim flanges by positioning a tire mounting band over the tire (Fig. 5). If

TIRE ROTATION

For longer tire life, all five tires should be cross-switched as shown in Fig. 3. See Group 19 for the specified interval.

a mounting band is not available, tie a tourniquet of heavy cord around the circumference of the tire. Tighten the cord with a tire iron. Center the tire on the wheel with a rubber mallet.

5. Give the tire a few quick bursts of air to seat the beads properly, then inflate the tire to 40 pounds pressure. Check to see that the bead positioning rings (outer rings near the side walls) are evenly visible just above the rim flanges all the way around the tire. If the rings are not even, deflate the tire completely and inflate it again.

6. When the rings are properly positioned, deflate the tire to the recommended pressure.

INSTALLATION

1. Clean all dirt from the hub and drum.

2. Position the wheel and tire assembly on the hub and drum. Install the wheel hub nuts and tighten them alternately in order to draw the wheel evenly against the hub and drum.

3. Lower the car to the floor, and torque the hub nuts to specification.

4. Install the hub cap or wheel cover taking care to center the valve stem in the hole provided.



F1021-A

FIG. 5—Tubeless Tire Mounting Band

OPERATIONS

If a bearing adjustment will not eliminate looseness or rough and noisy operation, the hub and bear-

ings should be cleaned, inspected, and repacked. If the bearing cups or the cone and roller assemblies

100% SATISFACTION GUARANTEED

BUY IT NOW!

Click Here To Order

AMERICAN EXPRESS

PayPal

Discover Cards

Discover Novus

MasterCard

VISA

are worn or damaged, they should be replaced.

1. Raise the car until the wheel and tire clear the floor.

2. Insert a narrow screwdriver through the brake adjusting hole at the inner side of the brake carrier plate, and disengage the adjusting lever from the adjusting screw. While holding the adjusting lever away from the screw, back off the adjusting screw with the brake adjusting tool (Fig. 6). **Be very careful not to burr, chip, or damage the notches in the adjusting screw; otherwise the self-adjusting mechanism will not function properly.**

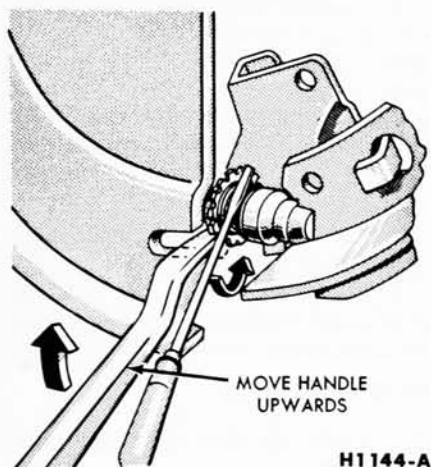

FIG. 6—Backing off Brake Adjustment

3. Remove the wheel cover or hub cap. Remove the grease cap from the hub. Remove the cotter pin, nut lock, adjusting nut, and flat washer from the spindle. Remove the outer bearing cone and roller assembly (Fig. 1).

4. Pull the wheel, hub, and drum assembly off the wheel spindle.

5. Remove the grease retainer and the inner bearing cone and roller assembly from the hub with tool 1175AE.

6. Clean the lubricant off the inner and outer bearing cups with solvent and inspect the cups for scratches, pits, excessive wear, and other damage. If the cups are worn or damaged, remove them with a drift.

7. Soak a new grease retainer in engine oil at least 30 minutes before installation.

Inspect the cones and rollers for wear or damage, and replace them if necessary. The cone and roller assembly, and the bearing cup should be replaced as a unit if either is damaged.

8. Thoroughly clean the spindle and the inside of the hub with solvent to remove all old lubricant.

Cover the spindle with a clean cloth, and brush all loose dust and dirt from the brake assembly. **To prevent getting dirt on the spindle, carefully remove the cloth from the spindle.**

9. If the inner and/or outer bearing cup(s) were removed, install the replacement cup(s) in the hub with the tool shown in Fig. 7. **Be sure to seat the cups properly in the hub.**

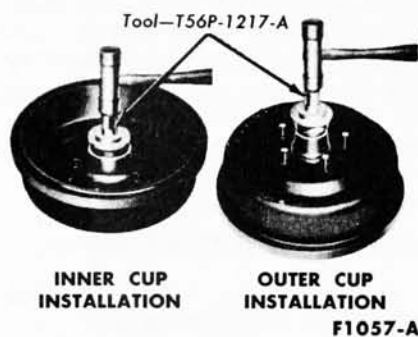

FIG. 7—Front Wheel Bearing Cup Installation

10. Pack the inside of the hub with specified wheel bearing grease. Add lubricant to the hub only until the grease is flush with the inside diameter of both bearing cups (Fig. 8).

11. Pack the bearing cone and roller assemblies with wheel bearing grease. A bearing packer is desirable for this operation. If a packer is not available, work as much lubricant as possible between the rollers and cages. Lubricate the cone surfaces with grease.

12. Place the inner bearing cone and roller assembly in the inner cup, and install the new grease retainer with the reverse end of the tool shown in Fig. 7. **Be sure that the retainer is properly seated.**

13. Install the wheel, hub, and drum assembly on the wheel spindle. **Keep the hub centered on the spindle to prevent damage to the grease retainer or the spindle threads.**

14. Install the outer bearing cone and roller assembly and the flat

washer on the spindle, then install the adjusting nut (Fig. 1).

15. Adjust the wheel bearings as outlined in Section 2, and install a new cotter pin. Bend the ends of the cotter pin around the castellations of the nut lock to prevent interference with the radio static collector in the grease cap. Install the grease cap.

16. Adjust the brake shoes as outlined in Part 2-2, Section 2.

17. Install the hub cap or wheel cover, taking care to center the valve stem in the hole provided.

FRONT HUB AND DRUM ASSEMBLY REPLACEMENT

When the hub and drum assembly is replaced, new bearings, cups, and grease retainer must be installed in the new assembly. The new grease retainer should be soaked in light engine oil at least 30 minutes before installation.

1. Raise the car until the wheel and tire clear the floor. Pry off the hub cap or wheel cover, and remove the wheel and tire assembly from the hub and drum assembly.

2. Back off the brake shoes and remove the old hub and drum assembly from the wheel spindle, as outlined in steps 2 and 3 of the foregoing procedure.

3. Remove the protective coating

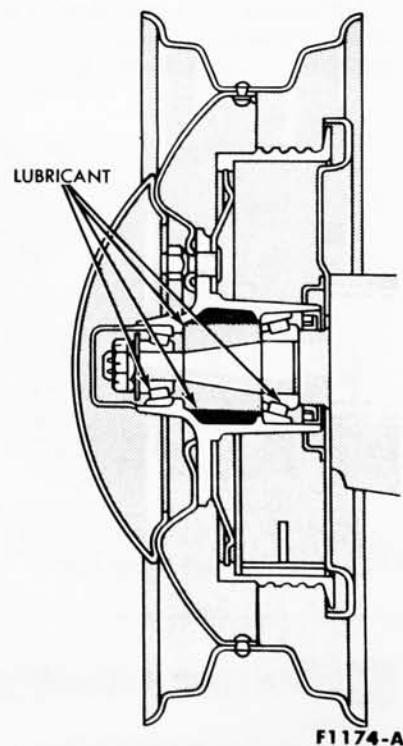

FIG. 8—Front Wheel Hub Lubrication

100% SATISFACTION GUARANTEED

BUY IT NOW!

Click Here To Order

PayPal American Express Discover Novus MasterCard VISA

from the new hub and drum with carburetor degreaser. Install new inner and outer bearing cups in the new hub with the tool shown in Fig. 7. **Be sure to seat the cups properly in the hub.**

4. Grease and install the new parts as outlined in steps 10 through 12 of the foregoing procedure.

5. Install the new hub and drum assembly to the wheel spindle. **Keep the hub centered on the spindle**

to prevent damage to the grease retainer.

6. Install the outer bearing cone and roller assembly and the flat washer on the spindle, then install the adjusting nut (Fig. 1).

7. Position the wheel and tire assembly on the new hub and drum assembly. Install the wheel hub nuts and tighten them alternately in order to draw the wheel evenly against the hub and drum.

8. Adjust the wheel bearings as outlined in Section 2, and install a new cotter pin. Bend the ends of the cotter pin around the castellations of the nut lock to prevent interference with the radio static collector in the grease cap. Install the grease cap.

9. Adjust the brake shoes as outlined in Part 2-2, Section 2.

10. Install the hub cap or wheel cover, taking care to center the valve stem in the hole provided.



PART 3-5 SPECIFICATIONS

FRONT SUSPENSION FRONT WHEEL ALIGNMENT

CASTER

Caster Angle	$-3/4^{\circ}$ to $-2 1/4^{\circ}$
Maximum Caster Angle Difference Between Wheels	$1/2^{\circ}$

CAMBER

Camber Angle	$+3/4^{\circ}$ to 0°
Maximum Camber Angle Difference Between Wheels	$1/2^{\circ}$ ($1/4^{\circ}$ preferred)
Maximum Allowable Thickness of Shim Stack at Each Bolt	$1 1/8$ inch
Amount of Camber Angle Change With $1/8$ -inch Change of Shim Thickness at Both Bolts	$1/3^{\circ}$

TOE-IN AND TOE-OUT

Toe-In	$1/8$ - $1/4$ inch
Toe-In on turn (Angle of outside wheel when inside wheel is turned 20°)	18° 53'

TORQUE LIMITS—FRONT SUSPENSION

Description	Ft-lbs
Lower Arm Ball Joint Assembly to Spindle Nut	60-80
Upper Arm Ball Joint Assembly to Spindle Nut	60-80
Upper Arm Shaft to Bushing	15-25
Stabilizer Link Nuts	8-13
Front Shock Absorber to Mounting Bracket	50-70
Front Shock Absorber Mounting Bracket to Upper Arm	40-55
Front Shock Absorber to Upper Mounting Plate	15-25
Front Shock Absorber Upper Mounting Plate Retaining Nuts	30-45
Stabilizer Brackets to Frame	11-18
Strut to Lower Arm Nuts	160-210
Lower Ball Joint to Lower Arm	60-80
Upper Ball Joint to Upper Arm	60-80
Spindle Connecting Rod to Spindle Arm	40-55
Upper Arm Inner Shaft to Body Crossmember	50-76
Strut to Underbody Bracket	70-90
Bracket to Underbody	85-115
	10-15
	60-80
0 in-lbs at 1 rpm	
	100

REAR SUSPENSION—TORQUE LIMITS

Description	Ft-lbs
Rear Shock Absorber Stud Nut (Upper or Lower)	15-25
Rear Axle Bumper Bracket to Underbody	20-30
Rear Spring Center Tie Bolt	5-15
Rear Spring Front Hanger to Underbody Side Rail	30-50
Rear Spring Front Eye, Stud, and Washer to Front Hanger	50-70
Rear Spring Rear Shackle Bar to Underbody	16-22
Rear Spring Rear Shackle Bar to Spring Rear Eye	16-22
Rear Spring to Rear Axle (U-Bolt Nuts)	50-60
Rear Spring Rear Hanger to Underbody Side Rail	50-60

REAR LEAF SPRINGS

Body Style	Number of Leaves	Capacity at Normal Load Height	Spring Length at Normal Load	Load	Rate
Hardtop	4	880-920 pounds	60 Inches	1020 ± 23	121 ± 6
Convertible	4	980-1020 pounds	60 Inches	1355 ± 24	134 ± 6

STEERING TORQUE LIMITS

STEERING LINKAGE	Ft-lbs.
Sector Shaft (Pitman) Arm Nut	110-150
Steering Arm to Idler Arm Rod Stud Nuts	40-55
Spindle Connecting Rod End Stud Nuts	40-55
Connecting Rod Sleeve Clamp Bolts	17-24
Idler Arm Bracket to Underbody Bolts	20-30
Idler Arm and Bushing to Bracket Nut	70-90

PUMP, STEERING GEAR, AND STEERING SHAFT

Steering Gear to Underbody Bolts	35-50
Sector Shaft Cover Bolts	23-27
Steering Wheel Nut	25-35
Flange to Insulator Bolts (Fixed Column)	10-15
Pump Drive to Crankshaft Pulley Bolts	20-25
Pump Bracket to Water Pump Housing Bolt	20-25
Pump Bracket Pivot Bolt	20-25
Pump Housing to Support Bracket	20-25
Pump Support Bracket to Cylinder Head	20-25
Drive Pulley and Crankshaft Pulley to Crankshaft	35-65

100% SATISFACTION GUARANTEED

BUY IT NOW!

Click Here To Order

0 in-lbs at 1 rpm

100

PayPal American Express Discover Novus MasterCard VISA