



**1964**

**COMET**

**and**

**FALCON**

**SHOP MANUAL**



**BUY IT NOW!**

**Click Here To Order**



Copyright © 2007, Forel Publishing Company, LLC, Woodbridge, Virginia

All Rights Reserved. No part of this book may be used or reproduced in any manner whatsoever without written permission of Forel Publishing Company, LLC. For information write to Forel Publishing Company, LLC, 3999 Peregrine Ridge Ct., Woodbridge, VA 22192

1964 Ford Car Shop Manual  
(with Technical Service Bulletin 1090-1, dated March 16, 1964)  
Form 7760-64

ISBN: 1-60371-001-9  
EAN: 978-1-60371-001-5

***Forel Publishing Company, LLC***  
***3999 Peregrine Ridge Ct.***  
***Woodbridge, VA 22192***  
***Email address: [webmaster@ForelPublishing.com](mailto:webmaster@ForelPublishing.com)***  
***Website: <http://www.ForelPublishing.com>***

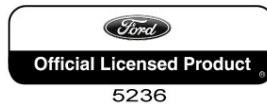

This publication contains material that is reproduced and distributed under a license from Ford Motor Company. No further reproduction or distribution of the Ford Motor Company material is allowed without the express written permission of Ford Motor Company.

---

## Disclaimer

Although every effort was made to ensure the accuracy of this book, no representations or warranties of any kind are made concerning the accuracy, completeness or suitability of the information, either expressed or implied. As a result, the information contained within this book should be used as general information only. The author and Forel Publishing Company, LLC shall have neither liability nor responsibility to any person or entity with respect to any loss or damage caused, or alleged to be caused, directly or indirectly by the information contained in this book. Further, the publisher and author are not engaged in rendering legal or other professional services. If legal, mechanical, electrical, or other expert assistance is required, the services of a competent professional should be sought.



# GROUP INDEX

# 1964

# COMET- FALCON

# SHOP MANUAL

IDENTIFICATION	1
BRAKES	2
SUSPENSION—STEERING—WHEELS & TIRES	3
REAR AXLE	4
CLUTCH—DRIVELINE	5
MANUAL TRANSMISSION	6
AUTOMATIC TRANSMISSION	7
ENGINE	8
IGNITION SYSTEM	9
FUEL SYSTEM	10
COOLING SYSTEM	11
EXHAUST SYSTEM	12
CHARGING SYSTEM	13
STARTING SYSTEM	14
LIGHTS, WIRING, ETC.	15
VENTILATING—HEATING—AIR/COND.—RADIO	16
BODY—FITS, SEATS, ETC.	17
SOFT TRIM—CONVERTIBLE TOP	18
MAINTENANCE SCHEDULE	19
MAINTENANCE OPERATIONS	20
LUBRICATION CHARTS	21
SPECIAL SERVICE TOOLS	22
INDEX	23

SPECIFICATIONS AT END OF EACH GROUP



**BUY IT NOW!**

**Click Here To Order**

PayPal

Discover  
Cards

Discover  
Novus

MasterCard

VISA

## FOREWORD

*This shop manual provides the Service Technician with complete information for the proper servicing of the 1964 Comet and Falcon cars.*

*The information is grouped according to the type of work being performed, such as diagnosis and testing, frequently performed adjustments and repairs, in-vehicle adjustments, overhaul, etc. Specifications and recommended special tools are included.*

*Refer to the opposite page for important vehicle identification data.*

*The descriptions and specifications in this manual were in effect at the time this manual was approved for printing. The Ford Motor Company reserves the right to discontinue models at any time, or change specifications or design, without notice and without incurring obligation.*

**SERVICE DEPARTMENT  
FORD MOTOR COMPANY**



**Official Licensed Product**

*Ford Motor Company*

5006

September 1997

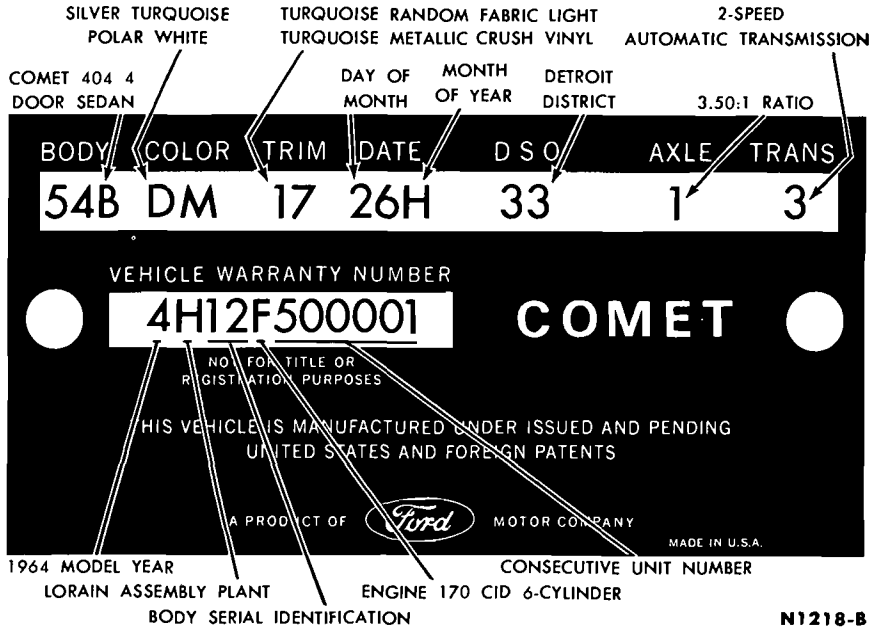

**FIG. 1—1964 Comet Warranty Plate**

Figure 1 illustrates the 1964 Comet warranty plate. The plate is located on the rear face of the left front door panel.

The official Vehicle Identification Number for title and registration purposes is stamped on the left fender apron (Fig. 2). Do not use the "Vehicle Warranty Number" which appears on the warranty plate for title or registration purposes.

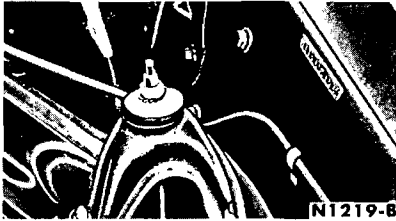

**FIG. 2—1964 Comet Vehicle Identification Number Location**

## MODEL AND BODY STYLE CODES

Serial Code	Body Code	Body Type	Model
02	54A	4-Door Sedan (Bench)	Comet 202
01	62A	2-Door Sedan (Bench)	Comet 404
12	54B	4-Door Sedan (Bench)	Comet 202 Station Wagon
11	62B	2-Door Sedan (Bench)	Comet 404 Station Wagon
11	62C	2-Door Sedan (Bucket)	Comet Caliente
32	71A	4-Door Wagon (Bench)	Comet 202 Station Wagon
34	71B	4-Door Wagon (Bench)	Comet 404 Station Wagon
36	71C	4-Door Woodrail Wagon (Bench)	Comet 404 Station Wagon
22	54C	4-Door Sedan (Bucket)	Comet Caliente
22	54D	4-Door Sedan (Bench)	Comet Caliente
23	63C	2-Door Hardtop (Bucket)	Comet Caliente
23	63D	2-Door Hardtop (Bench)	Comet Caliente
23	63E	2-Door Hardtop (Bucket)	Comet Caliente
25	76B	2-Door Convertible (Bucket)	Comet Caliente
25	76D	2-Door Convertible (Bench)	Comet Caliente

## VEHICLE DATA

Example (Fig. 1)

(54B DM 17 26H 33 1 3)	
54B	4-Door Sedan
DM	Silver Turquoise and Polar White
17	Turquoise Random Fabric Light Turquoise Metallic Crush Vinyl
26H	26th Day August
33	Detroit District
1	3.00:1 Ratio
3	2-Speed Automatic

## ASSEMBLY PLANT CODES

Code	Assembly Plant
H	Lorain
L	Los Angeles
M	Metuchen
P	Pilot Plant

## COLOR CODES

A single-letter code designates a solid body color and two letters denote a two-tone—the first letter, the lower color and the second letter, the upper color.

Code	M-30-J/ M-32-J*	Color	Sales Name
A	1724	Black	Onyx
B	1638	Peacock	Peacock
D	1625	Medium Turquoise Metallic	Silver Turquoise
F	1622	Medium Blue Metallic	Pacific Blue
G	1636	Buff	Palomino
J	1515	Red	Carnival Red
K	1621	Silver Blue Metallic	Anniversary Silver
M	1619	White	Polar White
R	1633	Yellow	Yellow Mist
T	1631	Light Beige	Fawn
X	1632	Maroon Metallic	Burgundy
Y	1623	Light Blue	Glacier Blue
Z	1630	Medium Beige Metallic	Platinum Beige

\*"M-32-J" Acrylic Paint Alternate with "M-30-J".



**BUY IT NOW!**

[Click Here To Order](#)



**TRIM CODES**

A two-digit number indicates the type of trim and trim color.

If, due to unavailability or other difficulties in production, a particular trim set is not intended for service (minor deviation from intended trim), the warranty plate code will be followed with a numerical designation—For example: 52-1, 52-2.

If the trim set is serviced directly, the warranty plate code will bear an alphabetical suffix—For example: 52-A, 52-B.

Code	Trim Schemes	
	<b>Random Fabric</b>	<b>and Crush Vinyl</b>
12.....	Blue.....	Light Blue Metallic
14.....	Beige.....	Light Beige Metallic
16.....	Black.....	Black
17.....	Turquoise.....	Light Turquoise Metallic
	<b>Bright Check Fabric</b>	<b>and Crush Vinyl</b>
21.....	Silver Blue.....	Light Silver Blue Metallic
22.....	Blue.....	Light Blue Metallic
24.....	Beige.....	Light Beige Metallic
26.....	Black.....	Black
27.....	Turquoise.....	Light Turquoise Metallic
		<b>Crush Vinyl (●) Crinkle</b>
32.....		Light Blue Metallic
35.....		Red
36.....		Black
37.....		Light Turquoise Metallic
39.....		Medium Palomino (●)
	<b>Block Stripe Fabric</b>	<b>and Crush Vinyl</b>
42.....	Blue.....	Light Blue Metallic
44.....	Beige.....	Light Beige Metallic
46.....	Black.....	Black
		<b>Crush Vinyl (●) Crinkle</b>
62.....		Light Blue Metallic
65.....		Red
66.....		Black
67.....		Light Turquoise Metallic
69.....		Medium Palomino (●)
		<b>Crush Vinyl (●) Crinkle</b>
72.....		Medium and Light Blue Metallic
75.....		Red
76.....		Black
79.....		Medium Palomino (●)
		<b>Crinkle Vinyl</b>
89.....		Medium Palomino

**DATE CODES**

A number signifying the date precedes the month code letter. A second-year code letter will be used if the model exceeds 12 months.

Month	Code First Year	Code Second Year
January.....	A.....	N.....
February.....	B.....	P.....
March.....	C.....	Q.....
April.....	D.....	R.....
May.....	E.....	S.....
June.....	F.....	T.....
July.....		U.....
August.....		V.....
September.....		W.....
October.....		X.....
November.....		Y.....
December.....		Z.....

**100% SATISFACTION GUARANTEED**

**BUY IT NOW!**

**Click Here To Order**

PayPal American Express Discover MasterCard VISA

**DSO AND DISTRICT CODES**

Units built on a Domestic Special Order, Foreign Special Order, or other special orders will have the complete order number in this space. Also to appear in this space is the two-digit code number of the District which ordered the unit. If the unit is a regular production unit, only the District code number will appear.

Code	District	Code	District
11.....	Boston	34.....	Detroit
12.....	Philadelphia	41.....	Chicago
13.....	New York	44.....	St. Louis
14.....	Washington	45.....	Twin Cities
21.....	Atlanta	51.....	Denver
22.....	Dallas	52.....	Los Angeles
24.....	Jacksonville	53.....	Oakland
25.....	Memphis	54.....	Seattle
31.....	Buffalo	81.....	Ford of Canada
32.....	Cincinnati	84.....	Home Office Reserve
33.....	Cleveland	90-99.....	Export

**REAR AXLE RATIO CODES**

A number designates a conventional axle, while a letter designates an Equi-Lock differential.

Code	Ratio
1.....	3.00:1
3.....	3.20:1
4.....	3.25:1
5.....	3.50:1
6.....	2.80:1

**TRANSMISSION CODES**

Code	Type
1.....	3-Speed Manual
3.....	2-Speed Automatic
4.....	Dual Range 3-Speed Automatic
5.....	4-Speed Manual

**VEHICLE WARRANTY NUMBER**

Example (Fig. 1): 4H 12F 500001

4.....	1964 Model Year
H.....	Lorain Pilot Plant Assembly
12.....	4-Door Sedan
F.....	8-Cylinder, 260 Cubic Inch Disp.
500001.....	First Unit Built (Consecutive Unit No.)

**MODEL YEAR CODE**

The numeral "4" designates 1964.

**ENGINE IDENTIFICATION CODES**

Code	Engine
U.....	6-Cylinder 170 Cubic Inch
T.....	6-Cylinder 200 Cubic Inch
F.....	8-Cylinder 260 Cubic Inch
K.....	8-Cylinder 289 Cubic Inch
*4.....	6-Cylinder 170 Cubic Inch
*6.....	8-Cylinder 260 Cubic Inch

\*Low Compression.

**CONSECUTIVE UNIT NUMBER**

Each model year, each assembly plant begins production with the number 500001 and continues on for each car built.

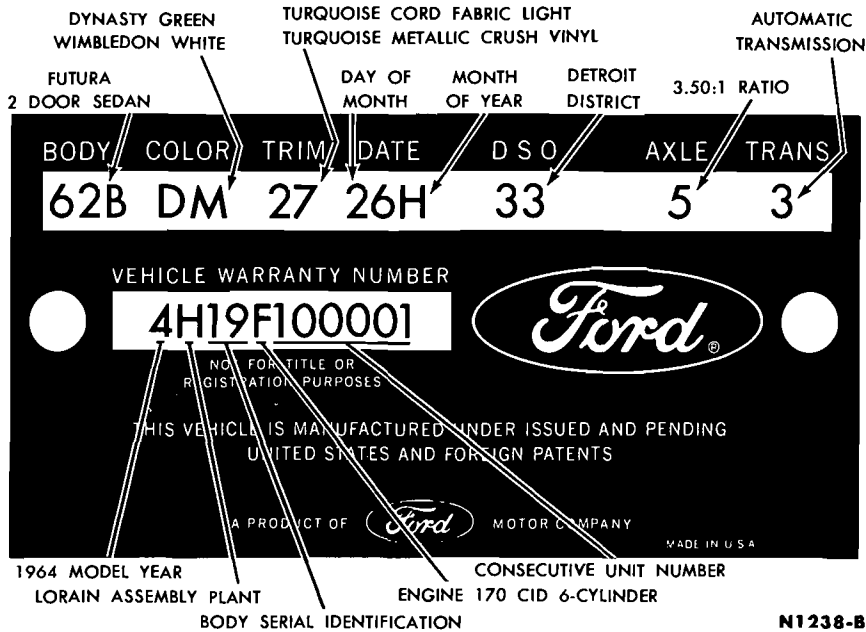

**FIG. 3—1964 Falcon Warranty Plate**

Figure 1 illustrates the 1964 Falcon Warranty Plate. The plate is located on the rear face of the left front door panel.

The official Vehicle Identification Number for title and registration purposes is stamped on the left cowl-to-front-spring pocket strut (Fig. 4). Do not use the "Vehicle Warranty Number" which appears on the Warranty plate for title or registration purposes.

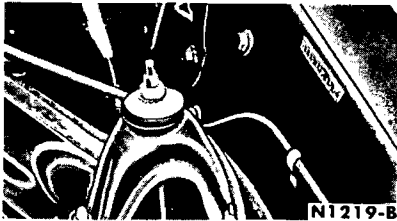

**FIG. 4—1964 Falcon Vehicle Identification Number Location**

### MODEL AND BODY STYLE CODES

Serial Code	Body Code	Body Type	Model
02	54A	4-Door Sedan	Standard Sedan
02	54D	4-Door Sedan (RPO)	
01	62A	2-Door Sedan	
01	62D	2-Door Sedan (RPO)	Futura
16	54B	4-Door Sedan ((Bench)	
19	62B	2-Door Sedan (Bench)	
17	63B	2-Door Hardtop (Bench)	
11	63C	2-Door Hardtop (RPO Bucket)	
13	63D	2-Door Hardtop Sprint (RPO Bucket)	
15	76A	Convertible (Bench)	Ranchero
12	76B	Convertible (RPO Bucket)	
14	76D	Convertible Sprint (RPO Bucket)	
21	59A	2-Door Wagon	Station Wagons
22	71A	4-Door Wagon	
24	71B	4-Door Wagon Deluxe	
26	71C	4-Door Squire	Sedan Delivery
27	66A	2-Door Standard Ranchero	
27	66B	2-Door Deluxe Ranchero	
29	78A	Standard Sedan Delivery	Sedan Delivery
29	78B	Deluxe Sedan Delivery	

### VEHICLE DATA

Example (Fig. 3):

(62B DM 27 26H 33 5 3)	
62B	Futura 2-Door Sedan
DM	Dynasty Green and Wimbleton White
27	Turquoise Cord Fabric Light Turquoise Met. Crush Vinyl
26H	26th Day August
33	Detroit District
5	3.50:1 Ratio
3	2-Speed Automatic

### ASSEMBLY PLANT CODES

Code	Assembly Plant
	Atlanta
	Lorain
	San Jose
	Pilot Plant
	Metuchen

### COLOR CODES

A single letter code designates a solid body color and two letters denote a two-tone—the first letter, the lower color and the second letter, the upper color.

Code	M-30-J/ M-32-J#	Color	Sales Name
A	1724	Black	Raven Black
D	1625	Medium Turquoise Metallic	Dynasty Green
F	1622	Medium Blue Metallic	Guardsman Blue
G	1636	Buff	Prairie Tan
J	1515	Red	Rangoon Red
K	1621	Silver Mink Metallic	Silvermore Gray
M	1619	White	Wimbleton White
X	1632	Maroon Metallic	Vintage Burgundy
Y	1623	Light Blue	Skylight Blue
Z	1630	Medium Beige Metallic	Chantilly Beige

# "M-32-J" Acrylic Paint Alternate with "M-30-J".



## BUY IT NOW!

Click Here To Order



**TRIM CODES**

Code	Trim Schemes
	Band Fabric and Crush Vinyl
12	Blue.....Light Blue Metallic
14	Beige.....Light Beige Metallic
15	Red.....Red
	Cord Fabric and Crush Vinyl
22	Blue.....Light Blue Metallic
24	Beige.....Light Beige Metallic
25	Red.....Red
27	Turquoise.....Light Turquoise Metallic
	Steerhead Vinyl
44	Medium Beige.....Light Beige Metallic
	Crush Vinyl (Bench) (●) Crinkle
62	.....Medium & Light Blue Metallic
64	.....Beige & Light Beige Metallic
65	.....Red
66	.....Black
67	.....Medium & Light Turquoise Metallic
69	.....Medium Palomino (●)
	Crush Vinyl (Bucket) (●) Crinkle
82	.....Medium & Light Blue Metallic
85	.....Red
86	.....Black
87	.....Medium & Light Turquoise Metallic
89	.....Medium Palomino (●)

**DATE CODES**

A number signifying the date precedes the month code letter. A second-year code letter will be used if the model exceeds 12 months.

Month	Code	
	First Year	Second Year
January	A	N
February	B	P
March	C	Q
April	D	R
May	E	S
June	F	T
July	G	U
August	H	V
September	J	W
October	K	X
November	L	Y
December	M	Z

**DSO AND DISTRICT CODES**

Units built on a Domestic Special Order, Foreign Special Order, or other special orders will have the complete order number in this space. Also to appear in this space is the two-digit code number of the District which ordered the unit. If the unit is a regular production unit, only the District code number will appear.

Code	District	Code	District
11	Boston	26	Washington
12	Buffalo	31	Cincinnati
13	New York	32	Cleveland
	Pittsburgh	33	Detroit
			Indianapolis
			Lansing
			Louisville
			Chicago
			Fargo
			Rockford

**DSO AND DISTRICT CODES (Continued)**

Code	District	Code	District
44	Twin Cities	65	Oklahoma City
45	Davenport	71	Los Angeles
51	Denver	72	San Jose
52	Des Moines	73	Salt Lake City
53	Kansas City	74	Seattle
54	Omaha	81	Ford of Canada
55	St. Louis	83	Government
61	Dallas	84	Home Office Reserve
62	Houston	85	American Red Cross
63	Memphis	89	Transportation Services
64	New Orleans	90-99	Export

**REAR AXLE RATIO CODES**

A number designates a conventional axle, while a letter designates an Equi-Lock differential.

Code	Ratio	Code	Ratio
2	3.10:1	B	3.10:1
3	3.20:1	C	3.20:1
4	3.25:1	D	3.25:1
5	3.50:1	E	3.50:1
9	4.00:1	I	4.00:1

**TRANSMISSION CODES**

Code	Type
1	3-Speed Manual
3	2-Speed Automatic
4	Dual Range
5	4-Speed Manual

**VEHICLE WARRANTY NUMBER**

Example (Fig. 3): 4H19F 100001

4	1964 Model Year
H	Lorain Pilot Plant Assembly
19	2-Door Sedan (Bench)
F	8-Cylinder, 260 Cubic Inch Disp.
100001	First Unit Built (Consecutive Unit Number)

**MODEL YEAR CODES**

The numeral "4" designates 1964

**ENGINE IDENTIFICATION CODES**

Code	Engine
S	6-Cylinder 144 Cubic Inch
U	6-Cylinder 170 Cubic Inch
*F	8-Cylinder 260 Cubic Inch
*4	6-Cylinder 170 Cubic Inch
*6	8-Cylinder 260 Cubic Inch

\*Low Compression.

**CONSECUTIVE UNIT NUMBER**

Each assembly plant begins production with the number 100001 and continues on for each car built.

**100% SATISFACTION GUARANTEED**

**BUY IT NOW!**

**Click Here To Order**

PayPal American Express Discover MasterCard VISA

# BRAKES

# GROUP 2

<b>PART 2-1</b>	<b>PAGE</b>	<b>PART 2-3</b>	<b>PAGE</b>
GENERAL BRAKE SERVICE .....	<b>2-1</b>	SPECIFICATIONS .....	<b>2-20</b>
<b>PART 2-2</b>			
BRAKE SYSTEM .....	<b>2-6</b>		

## PART 2-1 GENERAL BRAKE SERVICE

<b>Section</b>	<b>Page</b>	<b>Section</b>	<b>Page</b>
1 Diagnosis and Testing .....	2-1	3 Cleaning and Inspection .....	2-4
2 Common Adjustments and Repairs .....	2-3		

### 1 DIAGNOSIS AND TESTING

#### PRELIMINARY TESTS

1. Check the fluid in the master cylinder, and add FoMoCo heavy-duty brake fluid as required.

2. Push the brake pedal down as far as it will go while the car is standing. If the car is equipped with power brakes, the engine should be running while making this test. If the brake pedal travels more than halfway between the released position and the floor, check the automatic adjusters for being inoperative. To check adjuster operation, inspect the brake shoes and the adjuster mechanisms for binding or improper installation and follow the procedure described under "Brake Shoe Adjustments" in Part 2-2, Section 2.

Make several reverse stops to ensure uniform adjustment at all wheels. This procedure applies to power brakes only.

3. With the transmission in neutral, stop the engine and apply the parking brake. Depress the service brake pedal several times to exhaust all vacuum in the system. Then, de-

press the pedal and hold it in the applied position. Start the engine. If the vacuum system is operating, the pedal will tend to fall away under foot pressure and less pressure will be required to hold the pedal in the applied position. If no action is felt, the vacuum booster system is not functioning. Follow the procedures in the "Booster Diagnosis Guide".

4. With the engine shut off, exhaust all vacuum in the system (power brakes only). Depress the brake pedal and hold it in the applied position. If the pedal gradually falls away under this pressure, the hydraulic system is leaking. Check all tubing hoses, and connections for leaks.

If the brake pedal movement feels spongy, bleed the hydraulic system to remove air from the lines and cylinder. See "Hydraulic System Bleeding", Section 2. Also, check for leaks or insufficient fluid.

5. Should one of the brakes be locked and the car must be moved,

open the brake cylinder bleeder screw long enough to let out a few drops of brake fluid. **This bleeding operation will release the brakes, but it will not correct the cause of the trouble.**

#### ROAD TEST

The car should be road tested only if the brakes will safely stop the car. Apply the brakes at a speed of 25-30 mph to check for the existence of the trouble symptoms listed in Table 1, with the exception of those resolved in the preliminary tests and brake chatter. For each of the symptoms encountered, check and eliminate the causes which are also listed in Table 1. To check for brake chatter or surge, apply the brakes lightly from approximately 50 mph.

#### BOOSTER DIAGNOSIS GUIDE

For booster removal and installation procedures, refer to Part 2-2, Section 3. For disassembly and assembly procedures, refer to Part 2-2, Section 4. For cleaning and inspection refer to Part 2-1, Section 3.

#### TROUBLE SYMPTOMS, CAUSES, AND CORRECTIONS

If the preliminary tests show that the booster is inoperative or if a pedal condition still exists after diagnosing the causes of "Hard Pedal" listed in Table 1, the trouble can be caused by vacuum leakage. Disconnect the vacuum line at the master cylinder and remove the vacuum mani-

fold and check valve assembly, and look for a sticking or faulty check valve. Check all vacuum connections for leakage or obstruction. Check all hoses for a leaking or collapsed condition. Repair or replace parts as necessary.

If the foregoing procedure does

**100% SATISFACTION GUARANTEED**

**BUY IT NOW!**

**Click Here To Order**

PayPal American Express Discover MasterCard VISA

**TROUBLE SYMPTOMS, CAUSES, AND CORRECTIONS (Continued)**

<p><b>BOOSTER INOPERATIVE—HARD PEDAL (Continued)</b></p>	<p>not eliminate the trouble, remove the booster from the car. Separate the front shell from the rear shell, and check the valve and rod assembly reaction disc, diaphragm plate, and diaphragm assembly for damage that</p>	<p>would cause leaks. When assembling, be sure that the diaphragm assembly is properly positioned. Improper location could cause leakage between the vacuum and atmospheric sides of the diaphragm.</p>
<p><b>BRAKES DRAG OR GRAB</b></p>	<p>If the brakes still drag or grab after eliminating the causes listed in Table 1, the condition is probably caused by a sticking valve plunger</p>	<p>assembly. Remove and disassemble the booster. Clean, inspect, and replace parts as necessary.</p>
<p><b>SELF APPLICATION OF BRAKES WHEN ENGINE STARTS</b></p>	<p>Remove and disassemble the booster. Check for a leak in the rear shell. Check the diaphragm for being out of locating radii in the housing. Check for a sticking or un-</p>	<p>seated valve poppet. Clean, inspect, and replace parts as necessary. Be sure that the diaphragm is properly located when assembling.</p>

**TABLE 1—Brake Trouble Symptoms and Possible Causes**

Possible Causes of Trouble Symptoms	Trouble Symptoms												
	One Brake Drags	All Brakes Drag	Hard Pedal	Spongy Pedal	Car Pulls to One Side	One Wheel Locks	Brakes Chatter	Excessive Pedal Travel	Pedal Gradually Goes to Floor	Brakes Uneven	Shoe Click Release	Noisy or Grabbing Brakes	Brakes Do Not Apply
Mechanical Resistance at Pedal or Shoes													
Damaged Linkage		X	X										
Brake Line Restricted	X	X	X		X								
Leaks or Insufficient Fluid				X				X	X				X
Improper Tire Pressure					X					X			
Improperly Adjusted or Worn Wheel Bearing	X				X								
Distorted or Improperly Adjusted Brake Shoe	X	X	X		X	X		X				X	
Faulty Retracting Spring	X				X								
Drum Out of Round	X				X		X						
Linings Glazed or Worn			X		X	X	X	X				X	X
Oil or Grease on Lining			X		X	X	X			X		X	X
Loose Carrier Plate	X					X	X						
Loose Lining					X		X						
Scored Drum										X		X	
Dirt on Drum-Lining Surface												X	
Faulty Brake Cylinder	X				X	X						X	
Dirty Brake Fluid	X	X								X			X
Faulty Master Cylinder		X						X	X				X
Air in Hydraulic System	X			X				X					X
Self Adjusters Not Operating					X			X				X	
Insufficient Shoe-to-Breaking Plate Lubrication	X											X	
Tire Tread Worn						X							
Lining to Drum Contact							X						
							X						
												X	
								X					
		X										X	

**100% SATISFACTION GUARANTEED**

**BUY IT NOW!**

**Click Here To Order**

PayPal American Express Discover MasterCard VISA

**2 COMMON ADJUSTMENTS AND REPAIRS**

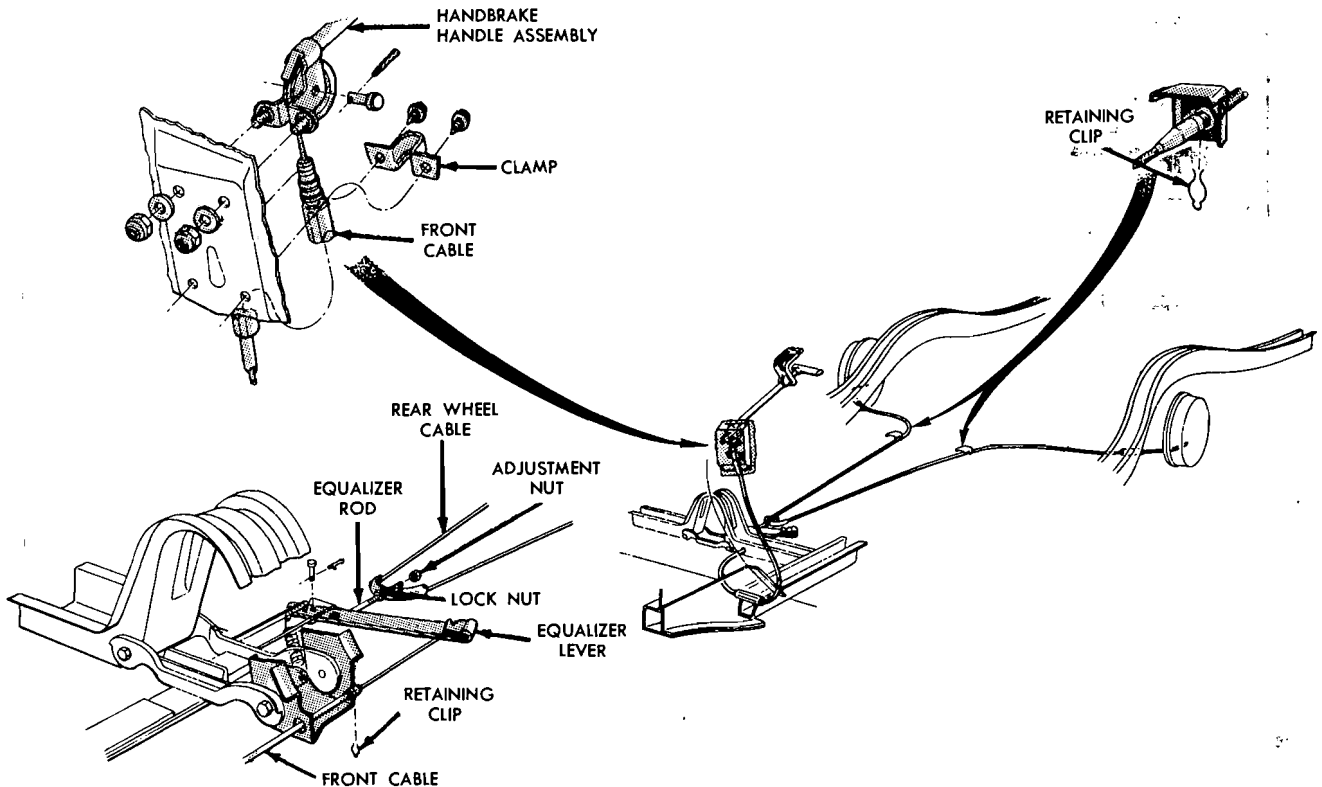

H1328-A

**FIG. 1—Parking Brake Linkage**

**PARKING BRAKE LINKAGE ADJUSTMENT**

Check the parking brake cables when the brakes are fully released. If the cables are loose, adjust them as follows.

1. Fully release the parking brake by turning the handle counterclockwise and pushing it inward.

2. Pull the parking brake handle outward one notch from its normal released position.

3. Raise the car.

4. Turn the lock nut in front of the equalizer (Fig. 1) several turns forward.

5. Turn the adjustment nut forward against the equalizer until a moderate drag is felt when turning the wheels.

the cables are properly

and no drag is felt when turning the rear wheels.

**MASTER CYLINDER PUSH ROD ADJUSTMENT—POWER BRAKES**

The push rod is provided with an adjustment screw to maintain the correct relationship between the booster control valve plunger and the master cylinder piston. Failure to maintain this relationship will prevent the master cylinder piston from completely releasing hydraulic pressure and can cause the brakes to drag, or cause excessive brake pedal travel.

To check the adjustment of the screw, fabricate a gauge of the dimensions shown in Fig. 2. Then place the gauge against the master cylinder mounting surface of the booster body as shown in Fig. 3. The push rod screw should be adjusted so that the end of the screw just touches the inner edge of the slot in the gauge. Do not set up side forces on the push rod. Side forces

may break the valve plunger.

This is an approximate adjustment only. The master cylinder piston should not move more than 0.015 inch as it contacts the push rod. No movement (exact contact) is ideal.

**HYDRAULIC SYSTEM BLEEDING**

When any part of the hydraulic

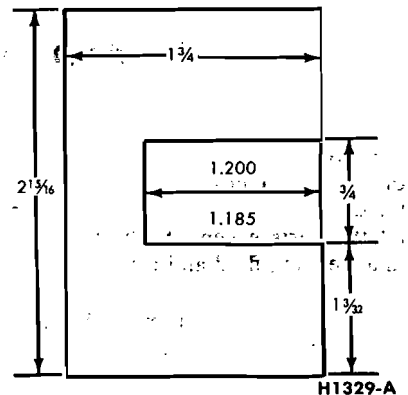

**FIG. 2—Push Rod Gauge Dimensions**

**100% SATISFACTION GUARANTEED**

**BUY IT NOW!**

**Click Here To Order**

PayPal, American Express, Discover, MasterCard, VISA

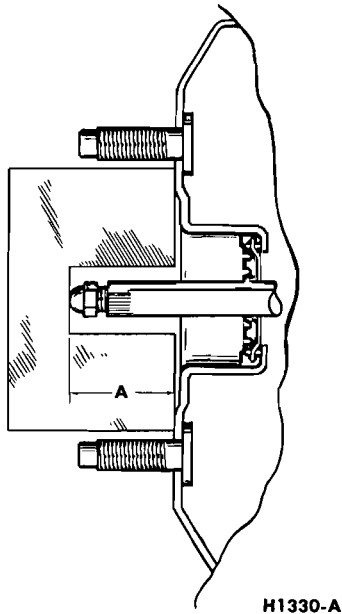

**FIG. 3—Push Rod Adjustment**

system has been disconnected for repair or replacement air may enter the system and cause spongy pedal action. Bleed the hydraulic system after it has been properly connected to be sure that all air is expelled.

The hydraulic system can be bled manually or with pressure bleeding equipment.

### MANUAL BLEEDING

Bleed the longest lines first. Keep the master cylinder reservoir filled with new heavy-duty brake fluid during the bleeding operation.

Never use brake fluid which has been drained from the hydraulic system.

1. Position a suitable  $\frac{3}{8}$ -inch box wrench (Fig. 4) on the bleeder fit-

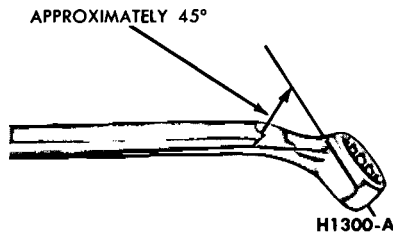

**FIG. 4—Wrench for Bleeding Brake**

ting on the right rear brake wheel cylinder. Attach a rubber drain tube to the bleeder fitting. **The end of the tube should fit snugly around the bleeder fitting.**

2. Submerge the free end of the tube in a container partially filled with clean brake fluid, and loosen the bleeder fitting approximately  $\frac{3}{4}$  turn.

3. Push the brake pedal down slowly thru its full travel. Close the bleeder fitting, then return the pedal to the fully-released position. Repeat this operation until air bubbles cease to appear at the submerged end of the bleeder tube.

4. When the fluid is completely free of air bubbles, close the bleeder fitting and remove the bleeder tube.

5. Repeat this procedure at each brake wheel cylinder in the following order: left rear, right front, and left front. Refill the master cylinder reservoir after each wheel cylinder is bled and when the bleeding operation is completed. The fluid level should be within  $\frac{3}{8}$  inch from the top of the reservoir.

### PRESSURE BLEEDING

Bleed the longest lines first. **Never use brake fluid which has been drained from the hydraulic system.**

The bleeder tank should contain

enough new heavy-duty brake fluid to complete the bleeding operation, and it should be charged with 10-30 pounds of air pressure.

1. Clean all dirt from the master cylinder reservoir cap.

2. Remove the master cylinder reservoir cap, install an adapter cap to the reservoir, and attach the bleeder tank hose to the fitting on the adapter cap. An adapter cap can be fabricated by cutting a hole in the center of a filler cap and soldering a right angle fitting in the hole. A right angle fitting must be used on power brakes to provide clearance at the body brace.

3. Position a  $\frac{3}{8}$ -inch box wrench (Fig. 4) on the bleeder fitting on the right rear brake wheel cylinder. Attach a bleeder tube to the bleeder fitting. **The end of the tube should fit snugly around the bleeder fitting.**

4. Open the valve on the bleeder tank to admit pressurized brake fluid to the master cylinder reservoir.

5. Submerge the free end of the tube in a container partially filled with clean brake fluid, and loosen the bleeder fitting.

6. When air bubbles cease to appear in the fluid at the submerged end of the bleeder tube, close the bleeder fitting and remove the tube.

7. Repeat this procedure at each brake wheel cylinder in the following order: left rear, right front, and left front.

8. When the bleeding operation is completed, close the bleeder tank valve and remove the tank hose from the adapter fitting.

9. Remove the adapter cap, refill the master cylinder reservoir to within  $\frac{3}{8}$  inch from the top of the reservoir, and install the filler cap.

## ③ CLEANING AND INSPECTION

### BRAKE ASSEMBLY

1. Remove the wheel from the drum, then remove the drum as outlined in Part 2-2, Section 2. Wash all the parts except the brake shoes in cleaning fluid and dry them with compressed air.

inch of any rivet head or if the shoes are damaged, they must be replaced. Replace any lining that has been oil saturated. Replace lining in axle sets. Prior to replacement of lining, the drum diameter should be checked to determine if oversize linings must be installed.

4. Check the condition of the brake shoes, retracting springs, and drum for signs of overheating. If the springs show any loss of load or change in free length, indicating overheating, replacement of the re-

tracting and hold down springs is necessary. **Overheated springs lose their pull and could cause the new lining to wear prematurely, if they are not replaced.**

5. If the car has 24,000 or more miles of operation on the brake linings or signs of overheating are present when relining brakes, the wheel cylinders should be disassembled and inspected for wear and entrance of dirt into the cylinder. The cylinder cups should be replaced, thus avoiding future problems.

**100% SATISFACTION GUARANTEED**

**BUY IT NOW!**

**Click Here To Order**

IF THE RUBBER IS WORN TO WITHIN 7/32"

PayPal American Express Cards Discover Novus MasterCard VISA

6. Inspect all other brake parts and replace any that are worn or damaged.

7. Inspect the brake drums and, if necessary, refinish them. Refer to Part 2-2, Section 4 for refinishing.

**BOOSTER UNIT**

A disassembled view of the brake booster is shown in Fig. 5.

After disassembly, immerse all metal parts in a suitable solvent. Use only alcohol on rubber parts or parts containing rubber. After the parts have been thoroughly cleaned and rinsed in cleaning solvent, the metal parts which come in contact with hydraulic brake fluid or rubber parts should be rewashed in clean alcohol before assembly. Use an air hose to blow dirt and cleaning fluid from the

recesses and internal passages. When overhauling a power booster, use all parts furnished in the repair kit. **Discard all old rubber parts.**

Inspect all other parts for damage or excessive wear. Replace damaged or excessively worn parts. If the inside of the booster shells are rusted or corroded, polish them with steel wool or fine emery cloth.

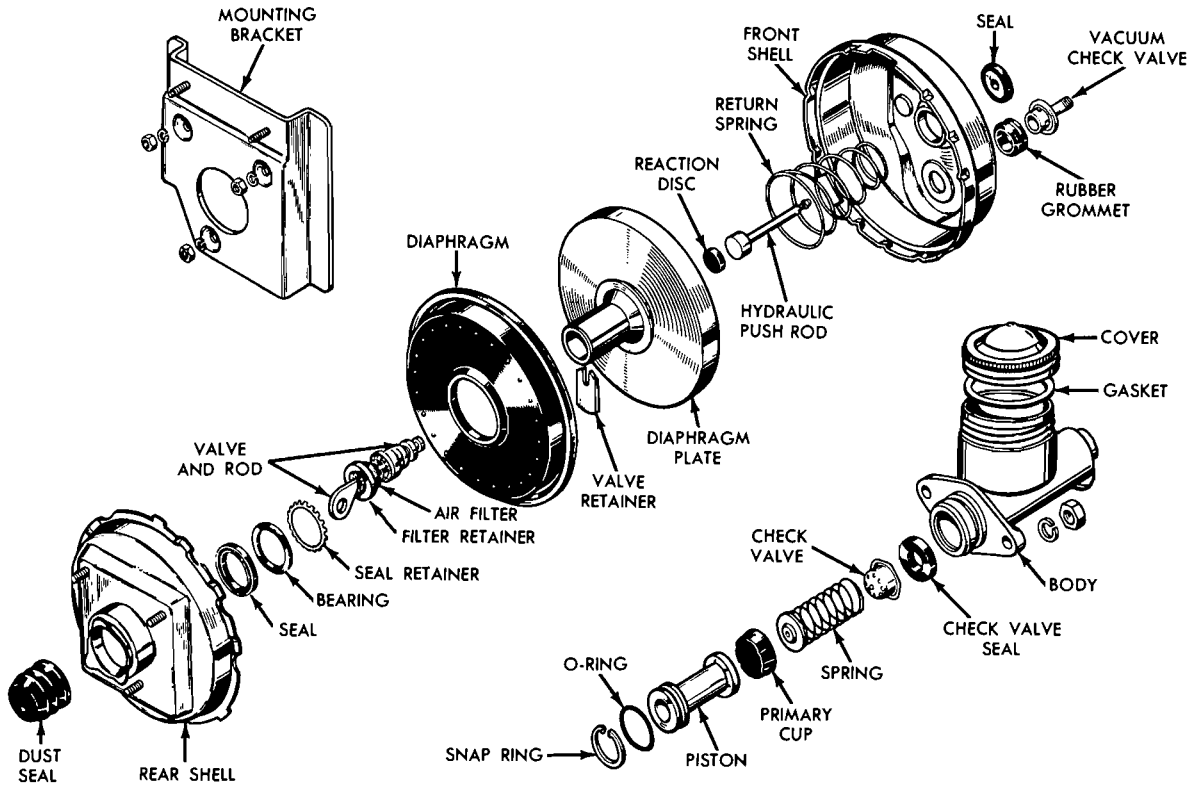

H1322-A

**FIG. 5—Brake Booster and Master Cylinder Disassembled**

**100% SATISFACTION GUARANTEED**

**BUY IT NOW!**

**Click Here To Order**

# PART 2-2 BRAKE SYSTEM

Section	Page
1 Description and Operation .....	2-6
2 In-Car Adjustments and Repairs .....	2-9
3 Removal and Installation .....	2-13
4 Major Repair Operations .....	2-16

## 1 DESCRIPTION AND OPERATION

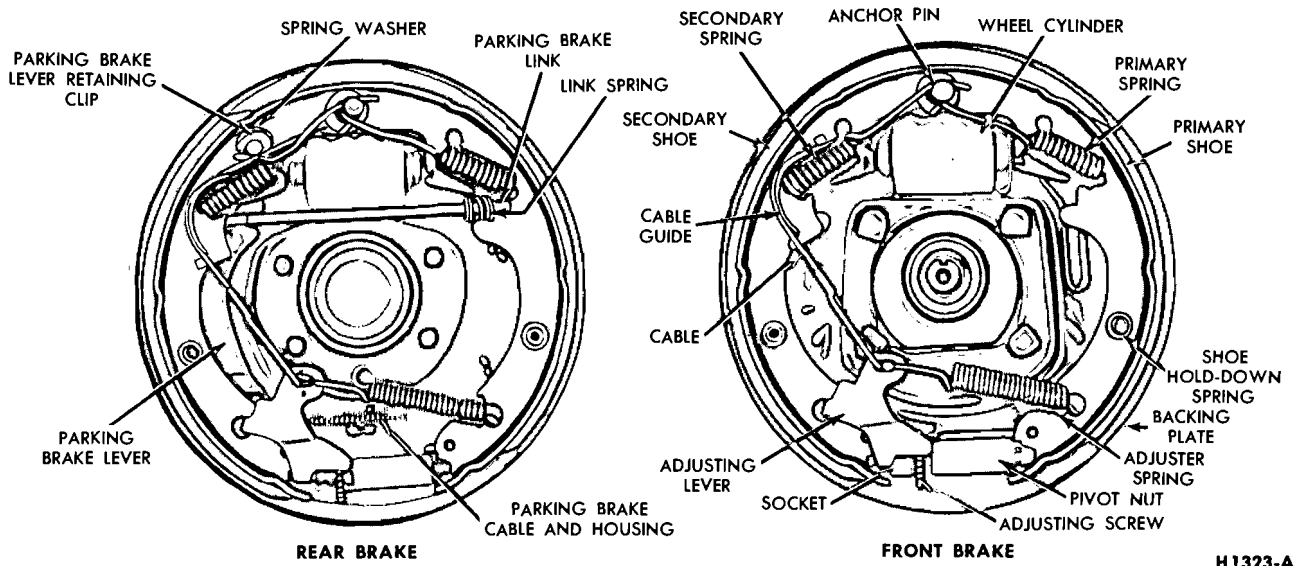

H1323-A

**FIG. 1—Self Adjusting Brake Assemblies**

### HYDRAULIC SELF ADJUSTING BRAKE SYSTEM

The hydraulic brake system employs single anchor, internal expanding and self-adjusting brake assemblies. A vacuum booster is available as optional equipment on all cars equipped with an automatic transmission.

The master cylinder converts physical force from the brake pedal and booster into hydraulic pressure against the pistons in the wheel cylinders. The wheel cylinder pistons in turn convert hydraulic pressure back into physical force at the brake shoes.

The self-adjusting brake mechanism consists of a cable, cable guide, adjusting lever, and adjuster spring (Fig. 1). The cable is hooked over the anchor pin at the top and is connected to the lever at the bottom.

rearward and only when the secondary shoe is free to move toward the drum beyond a predetermined point.

With the car moving rearward and the brakes applied, the "wrap-around" action of the shoes following the drum forces the upper end of the primary shoe against the anchor pin. The action of the wheel cylinder moves the upper end of the secondary shoe away from the anchor pin. The movement of the secondary shoe causes the cable to pull the adjusting lever upward and against the end of a tooth on the adjusting screw star-wheel. The upward travel of the lever increases as lining wear increases. When the lever can move upward far enough, it passes over the end of the tooth and engages the tooth. When the brakes are released, the adjusting spring pulls the level downward causing the star-wheel to turn and expand the shoes. The star-wheel is turned one tooth at a time as the linings progressively wear.

With the car moving forward and the brakes applied, the secondary shoe is against the anchor pin and the primary shoe is moved toward

the drum. Therefore, the adjuster does not operate.

The rear brake assembly is basically the same as the front brake. The conventional parking brake lever, link, and spring are used in the rear brake.

The anchor pins on all brakes are fixed and are non-adjustable.

### BOOSTER SYSTEM

The diaphragm type booster is a self-contained vacuum hydraulic power braking unit mounted on the engine side of the dash panel. It is of the vacuum suspended type which utilizes engine intake manifold vacuum and atmospheric pressure for its power. It consists of three basic elements combined into a single unit (Fig. 2).

The three basic elements are:

1. A vacuum power chamber which consists of a front and a rear shell, a power diaphragm, a hydraulic push-rod and a vacuum diaphragm return spring.

2. A mechanically actuated control valve integral with the vacuum power diaphragm controls the degree of

**100% SATISFACTION GUARANTEED**

**BUY IT NOW!**

**Click Here To Order**

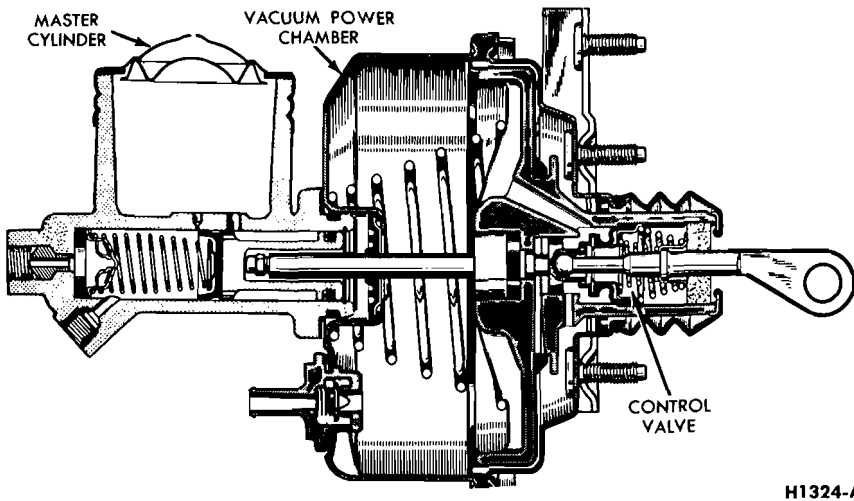

H1324-A

FIG. 2—Cutaway View of Vacuum Booster

power brake application or release in accordance with the foot pressure applied to the valve operating rod through the brake pedal linkage. The control valve consists of a single poppet with an atmospheric port and a vacuum port. The vacuum port seat is a part of the valve hub and diaphragm plate assembly. The atmospheric port seat is a part of the valve plunger which moves within the vacuum power diaphragm assembly.

3. A hydraulic master cylinder which contains all of the elements of the conventional brake master cylinder except for the hydraulic push-rod which has a self locking adjustment screw at one end with a piston head at the other end.

The vacuum power diaphragm and the components which make up the valve assembly are connected to the brake pedal through the valve operating rod and pedal linkage. The valve operating rod is connected to the valve plunger which moves within the power diaphragm assembly. A valve return spring holds the valve plunger and rod in the released position when pressure is released from the brake pedal. The valve poppet is of the flexible rubber type and is supported by the valve body. In the released position, the poppet return spring holds the poppet against the atmospheric port seat. A synthetic rubber seal is used to seal the open-

end of the valve sleeve. A rubber guard attached to a flange on the rear shell and over the air cleaner protects the valve housing and seal sleeve against dirt. A seal located in the front vacuum chamber seals the opening between the vacuum chamber and the hydraulic plunger. The hydraulic push rod forms the link between the vacuum power diaphragm assembly and the hydraulic piston of the master cylinder.

RELEASED POSITION

With the engine running and the

brakes released (Fig. 3), vacuum from the intake manifold is admitted through the check valve to the front (constant vacuum) chamber of the power unit. In the released position (no pressure applied to the brake pedal), the valve operating rod and valve plunger are held to the right in the valve housing by the valve return spring to CLOSE the atmospheric port and OPEN the vacuum port. With the valve in this position, the rear (control vacuum) chamber is also open to vacuum through the porting in the vacuum diaphragm and valve housing assembly. The vacuum power diaphragm is then "balanced" or suspended in vacuum, since vacuum is present on both sides of the power diaphragm. With the power diaphragm balanced in vacuum, the diaphragm return spring holds the diaphragm and hydraulic push rod in the fully released position. With the hydraulic push rod in this position, the hydraulic compensating port in the hydraulic master cylinder is OPEN to permit brake fluid to either return from the brake system to the fluid reservoir or enter the brake system from the fluid reservoir to compensate for any gain or loss in fluid volume.

APPLIED POSITION

When the brakes are applied (Fig. 4), the valve operating rod and valve

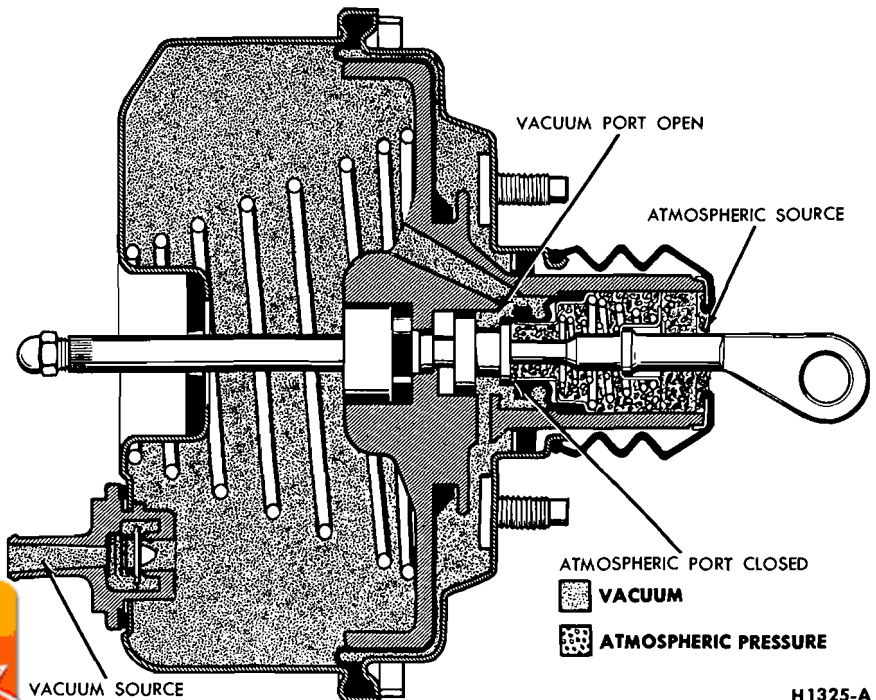

H1325-A

3—Booster in Released Position

**100% SATISFACTION GUARANTEED**

**BUY IT NOW!**

**Click Here To Order**

PayPal, American Express, Discover, MasterCard, VISA

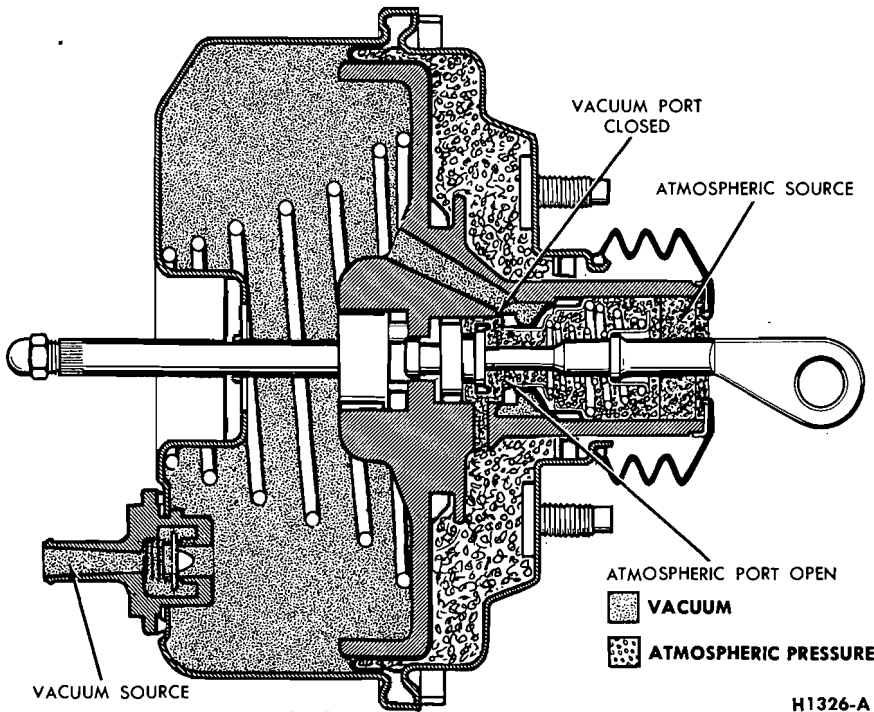

**FIG. 4—Booster in Applied Position**

plunger move to the left in the power diaphragm assembly to compress the valve return spring and bring the poppet valve into contact with the vacuum valve seat in the valve housing to "CLOSE" the vacuum port. Any additional movement of the valve operating rod in the applied direction moves the valve plunger away from the poppet valve to "OPEN" the atmospheric port and admit atmosphere through the air cleaner and passages in the diaphragm plate to the right side of the power chamber. With vacuum present on the left side of the diaphragm and valve housing and atmospheric pressure present on the right side of the diaphragm, a force is developed to move the vacuum power diaphragm assembly, hydraulic push rod and hydraulic piston to the left to close the compensating port and force hydraulic fluid under pressure through the residual check valve and brake tubes into the brake wheel cylinders. As hydraulic pressure is developed in the hydraulic cylinder, a counter force (to the right) acting through the hydraulic push rod, sets up a re-

force against the vacuum and the valve plunger in proportion to their respective contact areas. The pressure acting against the valve plunger and valve operating rod tends to move the valve plunger slightly to the right in relation to the diaphragm and valve housing assembly to close off the atmospheric port. The driver is thus assured a "feel" of the brake, since part of

the counter force reacts through the valve plunger, valve operating rod, and pedal linkage against the driver's foot. This reaction force is in direct proportion to the hydraulic pressure developed within the brake system.

**HOLDING POSITION**

During brake application, the "reaction" force which opposes the force applied by the driver, tends to close the atmospheric port. When both atmospheric and vacuum ports are CLOSED, the booster is said to be in the holding position. With both valves closed, any degree of brake application attained will be held until either the atmospheric port is reopened by an increase in pedal pressure to further increase the brake application or by a decrease in pedal pressure to reopen the vacuum port to decrease the brake application. Whenever the pressure applied to the brake pedal is held constant for a moment, the valve returns to its holding position. However, upon reaching the fully applied position the force applied to the brake pedal overrules the reaction force. In this position the valve plunger and atmospheric valve seat are held away from the valve poppet to admit maximum atmosphere pressure to the rear (right) chamber. With the front (left) chamber open to manifold vacuum, full power application is

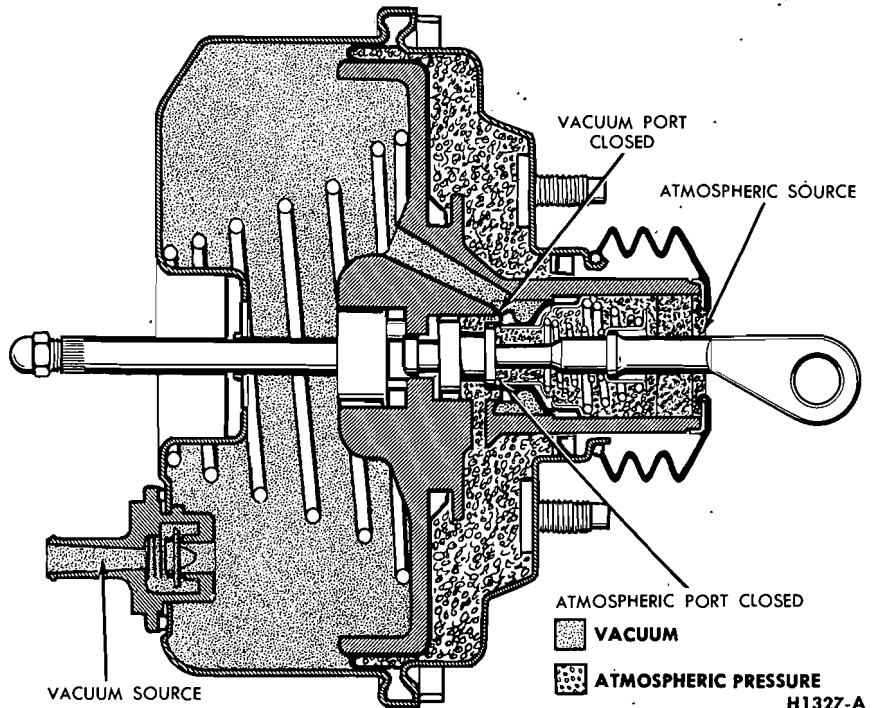

**FIG. 5—Booster in Holding Position**

**100% SATISFACTION GUARANTEED**

**BUY IT NOW!**

**Click Here To Order**

attained which is referred to as the "run-out" of the power unit. Any increase in hydraulic pressure beyond this point must be supplied by physical effort of the driver.

### NO POWER CONDITION

It should be noted that in case of engine failure and consequent loss of engine vacuum, at least one full power brake application may be made from the vacuum in the booster. With the engine off and no vacuum in the power system, the brakes

can be applied in the conventional manner by applying more physical effort to the brake pedal.

### PARKING BRAKES

An independent hand-operated parking brake control actuates the rear wheel brake shoes through a cable linkage. The operating cable is routed from the parking brake control assembly to the equalizer lever which is attached to the equalizer assembly. The rear brake cables

connect the equalizer assembly to the parking brake lever at each rear secondary shoe as shown in Fig. 1, Part 3-1.

When the handle is pulled the primary and secondary brake shoes are forced against the rear brake drums. The handle is held in the applied position by the engagement of a spring loaded pawl with a ratchet. Turning the handle counterclockwise disengages the pawl from the ratchet to release the brakes.

## 2 IN-CAR ADJUSTMENTS AND REPAIRS

### BRAKE SHOE ADJUSTMENTS

The car should be in a raised position with the wheels off the floor. **If the car is raised on a frame-contact hoist, disconnect the parking brake cables to prevent the rear brakes from being partially applied due to the rear axle and spring sag on the hoist.**

The hydraulic service brakes are self-adjusting and require a manual adjustment only after the brake shoes have been relined, replaced, or when the length of the adjusting screw has been changed while performing some other service operation.

The brake drums should be at normal room temperature when adjusting the brake shoes. If the shoes are adjusted when the drums are hot and expanded, the shoes may drag when the drums are cool and contracted.

1. After the shoes have been installed or the adjusting screw has been turned, install the drum. Be sure that all excess grease, oil, and other foreign material are wiped off the backing plate and drum.

Before installing the brake drum on the front wheel spindle, wipe the spindle completely free of grease. Install the drum carefully so that the grease seal retainers within the hub will not be damaged.

2. Remove the adjusting hole cover from the backing plate. Working from the backing plate side, turn the adjusting screw upward to expand the shoes (Fig. 6). Expand the shoes until a drag is felt when the drum is rotated.

3. **Remove the drum.** Mark the tooth on the star-wheel where the adjusting lever contacts it. While holding the adjusting lever out of engagement with the adjusting screw, back off the adjusting screw  $\frac{3}{4}$  of a turn with the fingers. If finger movement will not turn the screw, free it up; otherwise, the self-adjusting lever will not turn the screw. Lubricate the screw with a thin uniform coating of Stanolube—HD-Moly Grease—Grade 2.

**Any other adjustment procedure may cause damage to the adjusting screw with consequent self adjuster problems.**

4. Apply a small quantity of high-temperature grease to the points where the shoes contact the backing plate, being careful not to get the lubricant on the linings. Install the drum.

On front wheels, install the wheel outer bearing, washer, and adjusting nut, then adjust the wheel bearings as outlined in Part 3-4, Section 2.

On the rear wheels, install the three Tinnerman nuts and tighten carefully.

5. Install the wheel on the drum and tighten the mounting nuts to specification.

Install the adjusting hole cover on the brake backing plate.

7. When adjusting the rear brake shoes, check the parking brake cables for proper adjustment. Make sure that the equalizer lever operates freely.

8. After the brake shoes have been properly adjusted, check the operation of the brakes.

### FRONT BRAKE DRUM

#### REMOVAL

1. Raise the car until the wheel and tire clear the floor. Remove the wheel cover or hub cap, and remove the wheel and tire assembly from the drum.

2. If the brake drum will not come off easily, insert a narrow screwdriver through the brake adjusting hole in the backing plate, and disengage the adjusting lever from the adjusting screw. While thus holding the adjusting lever away from the adjusting screw, back off the adjusting screw with the brake adjusting tool shown in Fig. 7. **Back off the adjustment only if the drum cannot be removed. Be very careful not**

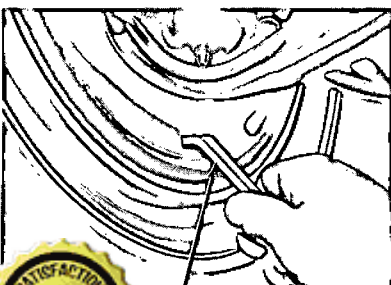

**100% SATISFACTION GUARANTEED**

**BUY IT NOW!**

**Click Here To Order**

PayPal | American Express | Discover | MasterCard | VISA

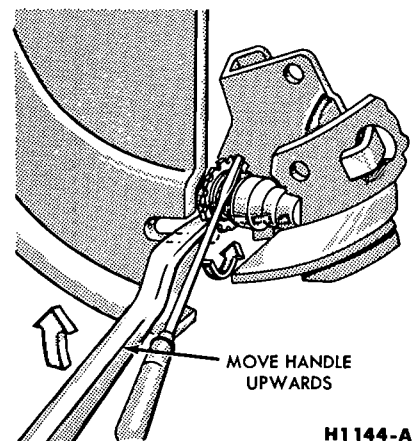

H1144-A

**FIG. 7—Backing Off Brake Adjustment**

to burr, chip, or damage the notches in the adjusting screw; otherwise, the self-adjusting mechanism will not function properly. If the adjustment was backed off, make sure that the adjuster lever is properly seated in the shoe web.

3. Remove the grease cap from the hub. Remove the cotter pin, nut lock, adjusting nut, and flat washer from the spindle. Remove the outer bearing cone.

4. Pull the hub and drum assembly off the spindle.

### INSTALLATION

1. If the drum is being replaced, remove the protective coating from the new drum with carburetor degreaser. Install new bearings and grease retainer. Soak the new grease retainer in light engine oil at least 30 minutes before installation. Pack the wheel bearings, install the inner bearing cone and roller assembly in the inner cup, and install the new grease retainer. See Part 3-4, Section 4.

If the original drum is being installed, make sure that the grease in the hub is clean and adequate.

2. Install the drum assembly, outer wheel bearing, washer and the adjusting nut.

3. Adjust the wheel bearing as outlined in Part 3-1, Section 2. Install the nut lock and cotter pin. Then install the grease cap.

4. Install the wheel and hub cap. If the adjustment was backed off, adjust the brake as outlined under "Brake Shoe Adjustments".

### REAR BRAKE DRUM

#### REMOVAL

1. Raise the car so that the wheel is clear of the floor.

2. Remove the hub cap and wheel. Remove the three Tinnerman nuts and remove the brake drum.

If the brake drum will not come off, insert a narrow screwdriver through the brake adjusting hole in the backing plate, to disengage the adjusting lever from the adjusting screw. While holding the adjusting lever away from the adjusting screw, back off the adjusting screw with brake adjusting tool (Fig. 7).  
off the adjustment only if

backed off, make sure that the adjuster lever is properly seated in the shoe web.

### INSTALLATION

1. Remove the protective coating from a new drum with carburetor degreaser.

2. Place the drum over the brake assembly and into position. Adjust the brakes as outlined under "Brake Shoe Adjustments" in this section.

3. Install the three Tinnerman nuts and tighten them securely. Install the wheel on the axle shaft flange studs against the drum, and tighten the retaining nuts to specifications.

### BRAKE SHOES AND ADJUSTING SCREW

#### REMOVAL

1. With the wheel and drum removed, install a clamp over the ends of the brake cylinder as shown in Fig. 8.

2. Contract the shoes as follows:

a. Disengage the adjusting lever from the adjusting screw by pulling backward on the adjusting lever (Fig. 1).

b. Move the outboard side of the adjusting screw upward and back off the pivot nut as far as it will go.

3. Pull the adjusting lever, cable and automatic adjuster spring down and toward the rear to unhook the pivot hook from the large hole in the secondary shoe web. **Do not attempt to pry the pivot hook out of the hole.**

4. Remove the automatic adjuster spring and adjusting lever (Fig. 1).

5. On cars equipped with a 6-cylinder engine, remove the secondary shoe to anchor spring with the tool shown in Fig. 8. Unhook the cable eye from the anchor pin. With the same tool, remove the primary shoe to anchor spring. On cars equipped with an 8-cylinder engine, unhook

the secondary and the primary shoe to anchor springs. Unhook the cable eye from the anchor pin.

6. Remove the cable guide from the secondary shoe (Fig. 1).

7. Remove the shoe hold-down springs, shoes, adjusting screw, pivot nut, and socket.

8. On rear brakes, remove the parking brake link and spring. Disconnect the parking brake cable from the parking brake lever.

9. After removing the rear brake secondary shoe, disassemble the parking brake lever from the shoe by removing the retaining clip and spring washer (Fig. 1).

### INSTALLATION

1. Before installing the rear brake shoes, assemble the parking brake lever to the secondary shoe and secure it with the spring washer and retaining clip.

2. Apply a light coating of high-temperature grease at the points where the brake shoes contact the backing plate.

3. Position the brake shoes on the backing plate and secure them with the hold down springs. On the rear brake, install the parking brake link and spring. Connect the parking brake cable to the parking brake lever.

4. On a car equipped with an 8-cylinder engine, position the adjuster cable eye over the anchor pin with the crimped side toward the backing plate.

Install the cable guide on the secondary shoe web with the flanged hole properly fitted into the hole in the secondary shoe web. Install the secondary shoe to anchor spring. Install the primary shoe to anchor spring.

5. On a car equipped with a 6-cylinder engine, install the cable guide on the secondary shoe web with the flanged hole properly fitted into the hole in the secondary shoe web. Install the secondary shoe to anchor spring (Fig. 1).

Place the cable eye over the anchor pin with the crimped side toward the backing plate. Install the primary shoe to anchor spring with the tool shown in Fig. 9.

6. Thread the cable around the cable guide groove.

It is imperative that the cable be positioned in this groove and

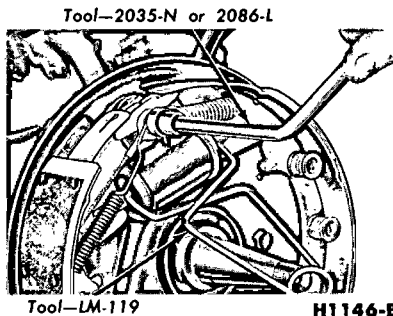

**FIG. 8—Retracting Spring Removal**



**BUY IT NOW!**

**Click Here To Order**



Tool—2035-N or 2086-L

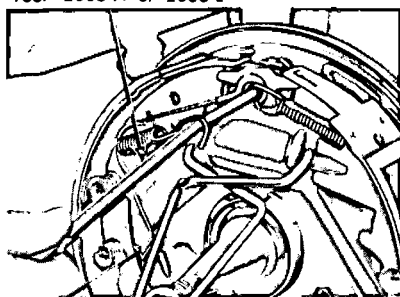

Tool—LM-119

H1147-B

### FIG. 9—Retracting Spring Installation

not between the guide and the shoe web. Be certain that the cable eye is not cocked or binding on the anchor pin when installed. All parts should be flat on the anchor pin. Remove the brake cylinder clamp.

7. Apply high-temperature grease (Stanalube Poly) to the threads and the socket end of the adjusting screw. Turn the adjusting screw into the adjusting pivot nut to the limit of the threads and then back off  $\frac{1}{2}$  turn.

Interchanging the brake shoe adjusting screw assemblies from one side of the car to the other would cause the brake shoes to retract rather than expand each time the automatic adjusting mechanism operated. To prevent accidental installation of the adjusting screw on the wrong side of the car the socket end of the adjusting screw is stamped with an R or L (Fig. 10). The adjusting pivot nuts can be distinguished by the number of grooves machined around the body of the nut. Two grooves indicate a right-hand nut; one groove indicates a left-hand nut.

8. Place the adjusting socket on the screw and install this assembly between the shoe ends with the adjusting screw toothed wheel nearest the secondary shoe.

9. Hook the cable hook into the hole in the adjusting lever. The adjusting levers are stamped with an R or L to indicate their installation on a right- or left-hand brake assembly (Fig. 10).

10. Position the hooked end of the adjuster spring completely into the large hole in the primary shoe web. The last coil of the spring should be at the edge of the hole. Connect the loop end of the spring to the adjuster lever hole (Fig. 1).

11. Pull the adjuster lever, cable and automatic adjuster spring down and toward the rear to engage the pivot hook in the large hole in the secondary shoe web.

12. After installation, check the action of the adjuster by pulling the section of the cable between the cable guide and the adjusting lever toward the secondary shoe web far enough to lift the lever past a tooth on the adjusting screw wheel. The lever should snap into position behind the next tooth, and release of the cable should cause the adjuster spring to return the lever to its original position. This return action of the lever will turn the adjusting screw one tooth.

If pulling the cable does not produce the action described, or if the lever action is sluggish instead of positive and sharp, check the position of the lever on the adjusting screw toothed wheel. With the brake in a vertical position (anchor at the top), the lever should contact the adjusting wheel  $\frac{3}{16}$  inch (plus or minus  $\frac{1}{32}$  inch) above the centerline of the screw. If the contact point is below this centerline, the lever will not lock on the teeth in the adjusting screw wheel, and the screw will not be turned as the lever is actuated by the cable.

To determine the cause of this condition:

a. Check the cable end fittings. The cable should completely fill or extend slightly beyond the crimped section of the fittings. If it does not meet this specification, possible damage is indicated and the cable assembly should be replaced.

b. Check the cable length. The cable should measure  $8\frac{7}{16}$  inches on cylinder models or  $10\frac{1}{8}$  inches on 8-cylinder models from the end of the cable anchor to the end of the cable hook.

c. Check the cable guide for damage. The cable groove should be parallel to the shoe web, and the body of the guide should lie flat against the web. Replace the guide if it shows damage.

d. Check the pivot hook on the lever. The hook surfaces should be square with the body of the lever for proper pivoting. Replace the lever if the hook shows damage.

e. See that the adjusting screw socket is properly seated in the notch in the shoe web.

### WHEEL CYLINDER REPAIR

It is not necessary to remove the brake cylinder from the backing plate to disassemble, inspect, or hone and overhaul it. Removal is necessary only when the cylinder is damaged or scored beyond repair.

### DISASSEMBLY

1. Remove the links and the rubber boots from the ends of the brake cylinder. The 6-cylinder models are not provided with links. Remove the pistons, cups, and return spring from the cylinder bore (Fig. 11).

2. Remove the bleeder screw from the cylinder.

### INSPECTION

1. Wash all parts in clean de-natured alcohol. If alcohol is not available, use specified brake fluid. Dry with compressed air.

2. Check all internal parts for excessive wear or damage. If any of the internal parts require replacing, all should be replaced.

3. Inspect the cylinder bore for score marks or rust. If either condition is present, the cylinder bore must be honed. However, the cylinder should not be honed more than 0.003 inch beyond its original diameter. A baffle in the front wheel cylinder of the 6-cylinder models prevents honing, therefore, they must be replaced.

4. Check the bleeder hole to be sure that it is open.

### ASSEMBLY

1. Apply a coating of heavy-duty brake fluid to all internal parts.

2. Thread the bleeder screw into the cylinder and tighten securely.

3. Insert the return spring, cups, and pistons into their respective positions in the cylinder bore (Fig. 11). Place a boot over each end of the cylinder.

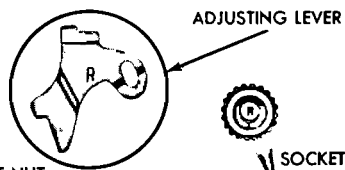

PIVOT NUT

SOCKET



**BUY IT NOW!**

**Click Here To Order**



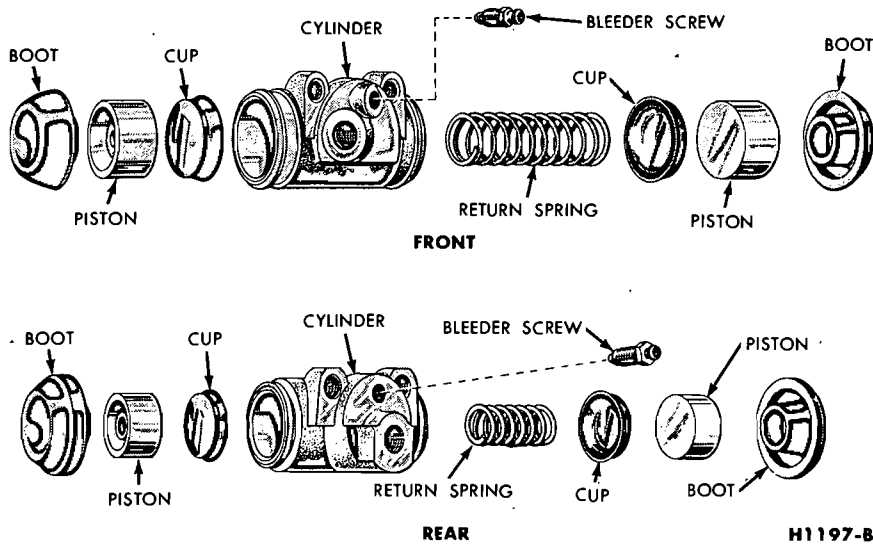

FIG. 11—Front and Rear Wheel Cylinders

### WHEEL CYLINDER REPLACEMENT

#### REMOVAL

1. With the wheel in a raised position, remove the wheel and the drum.

2. Place a clamp over the ends of the brake cylinder as shown in Fig. 9.

4. Remove the brake shoe assemblies, following procedures outlined in this section.

4. Disconnect the brake line from the brake cylinder. On a car with a vacuum brake booster, be sure the engine is stopped and there is no vacuum in the booster system before disconnecting the hydraulic lines.

To disconnect the hose at a front cylinder, loosen the tube fitting that connects the opposite end of the hose to the brake tube at a bracket on the frame. Remove the horseshoe-type retaining clip from the hose and bracket, disengage the hose from the bracket, then unscrew the entire hose assembly from the front wheel cylinder.

At a rear cylinder, unscrew the tube fitting that connects the tube to the cylinder. Do not pull the metal tube away from the cylinder. Pulling the tube out of the cylinder connection will bend the tube and make installation

#### INSTALLATION

Wipe the end(s) of the hydraulic line to remove any foreign matter before making connections.

##### 1. To install a front cylinder:

a. Position the cylinder in place against the backing plate. Install the two lock washers and attaching bolts. Torque them to specifications.

b. Install a new copper gasket over the hose fitting. Thread the hose assembly into the cylinder and tighten it securely.

c. Engage the opposite end of the hose to the bracket on the frame, install the horseshoe-type retaining clip, and connect the brake tube to the hose with the tube fitting nut. Tighten the nut to specifications.

##### 2. To install a rear cylinder:

a. Position the rear wheel cylinder in place against the backing plate. Enter the tubing into the cylinder, and start the tube fitting nut into the threads of the cylinder.

b. Secure the cylinder to the backing plate with the attaching bolts and lock washers.

c. Tighten the tube fitting nut to specifications.

3. Install the links in the ends of the wheel cylinder (8-cylinder models only).

4. Install the brake shoes as detailed in this section.

5. Install the brake drums and wheels.

6. Bleed the brakes as detailed in Part 2-1, Section 2.

7. Adjust the brakes as detailed in Part 2-2, Section 2.

### BRAKE BACKING PLATE REPLACEMENT

#### REMOVAL

1. Remove the wheel and brake drum. Disconnect the brake line from the brake cylinder.

2. Remove the brake shoe and adjuster assemblies and the wheel cylinder as outlined in this section. On the rear wheels, disconnect the parking brake lever from the cable.

3. If the rear backing plate is being replaced, rotate the axle shaft so that the hole in the axle shaft flange lines up with the backing plate retaining nuts and remove the nuts. Pull the axle shaft assembly out of the housing with tool #4235-C and a slide hammer (Part 4-2), then remove the backing plate.

If the front backing plate is being replaced, remove the bolts and nuts that secure the plate to the front wheel spindle and remove the plate.

#### INSTALLATION

1. Position a new rear backing plate on the retaining bolts in the axle housing flange. Insert the axle shaft into the housing so that the splines engage the differential side gear with the bearing retainer sliding onto the retaining bolts and against the backing plate. Install the retaining nuts through the access hole in the axle shaft flange.

Position a new front backing plate to the wheel spindle and install the retaining bolts and nuts.

2. Install the wheel cylinder and connect the brake line as outlined in this section.

3. Install the brake shoe and adjuster assemblies as outlined in this section. On a rear brake, connect the parking brake cable to the lever. Install the brake drum and wheel.

4. Adjust the brake shoes (Section 2), and bleed the brake system as outlined in Part 2-1, Section 2.

#### HYDRAULIC LINES

Steel tubing is used throughout the brake system with the exception

**100% SATISFACTION GUARANTEED**

**BUY IT NOW!**

**Click Here To Order**

PayPal American Express Discover/Novus MasterCard VISA

of the flexible hoses at the front wheels and at the rear axle housing brake tube connector (Fig. 12).

Always bleed the entire hydraulic system after any hose or line replacement.

### BRAKE TUBE REPLACEMENT

If a section of the brake tubing becomes damaged, the entire section should be replaced with tubing of the same type, size, shape, and length. Copper tubing should not be used in a hydraulic system. When bending brake tubing to fit underbody or rear axle contours, be careful not to kink or crack the tube.

All brake tubing should be flared

properly to provide good leak-proof connections. Clean the brake tubing by flushing with clean denatured alcohol, before installation.

When connecting a tube to a hose, tube connector, or brake cylinder, tighten the tube fitting nut to specified torque with Milbar tool 1112-144 or equivalent.

### BRAKE HOSE REPLACEMENT

A flexible brake hose should be replaced if it shows signs of softening, cracking, or other damage.

When installing a new front brake hose, position the hose to avoid contact with other chassis parts. Place a new copper gasket over the hose

fitting and screw the hose assembly into the front brake cylinder. Engage the opposite end of the hose to the bracket on the frame. Install the horseshoe-type retaining clip, and connect the tube to the hose with the tube fitting nut.

A rear brake hose should be installed so that it does not touch the muffler outlet pipe or shock absorber.

Place a new gasket over the rear hose fitting and screw the hose assembly into the rear brake tube connector. Engage the front end of the hose to the bracket on the frame. Install the horseshoe-type retaining clip, and connect the tube to the hose with the tube fitting nut.

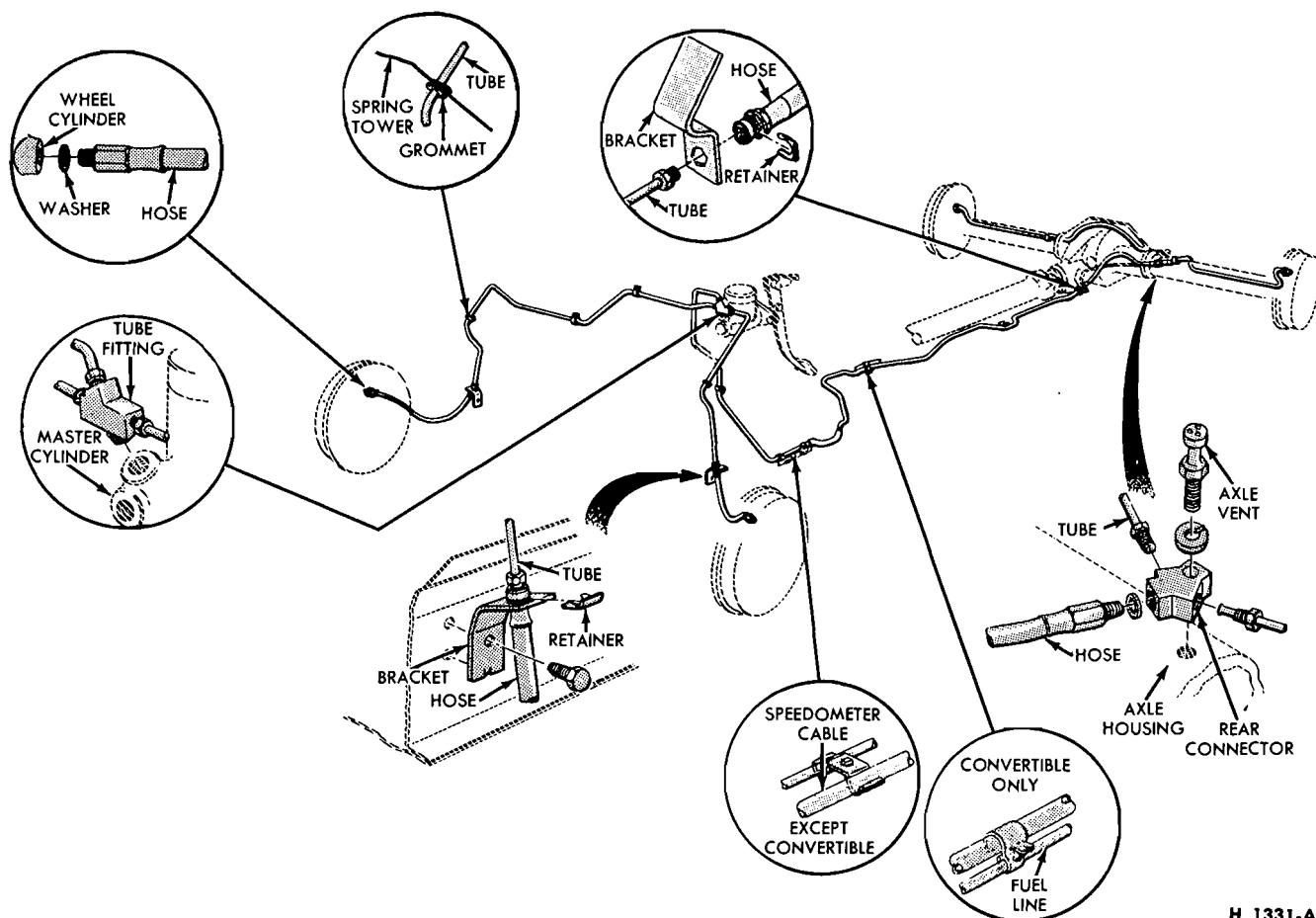

FIG. 12—Hydraulic Brake System

H 1331-A

## 3 REMOVAL AND INSTALLATION

MASTER CYLINDER—

**100% SATISFACTION GUARANTEED**  
**BUY IT NOW!**  
 Click Here To Order

PayPal American Express Discover NetPlus MasterCard VISA

the master cylinder. Disconnect the top light switch wires from the switch (Fig. 13).

Remove the bolts that secure the master cylinder to the dash panel and lift the cylinder out and away from the push rod. Remove the rubber boot from the push rod.

### INSTALLATION

1. With the rubber boot on the push rod, guide the master cylinder over the end of the push rod, and position the cylinder against the dash panel.

2. Install and torque the mounting

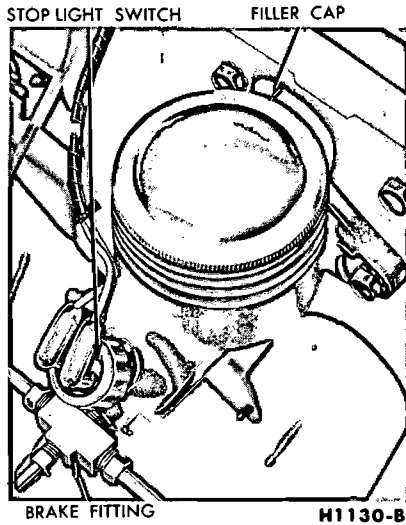

**FIG. 13—Brake Master Cylinder Installed**

bolts to specification.

3. Connect the brake line to the master cylinder fitting, but leave the brake line fitting loose.

4. Fill the master cylinder reservoir with heavy-duty brake fluid to within  $\frac{3}{8}$  inch of the top. Install and tighten the filler cap.

5. Bleed the master cylinder to let air escape from the cylinder at the brake line fitting. Then tighten the fitting.

6. Remove the filler cap and fill the reservoir to the level specified. Install the cap and wipe off any fluid from the cylinder.

7. Connect the wires to the stop light switch and the rubber boot to the master cylinder.

### MASTER CYLINDER—POWER BRAKES

#### REMOVAL

1. Disconnect the battery ground cable from the battery.

2. Disconnect the stop light switch wires from the switch.

3. Disconnect the hydraulic line from the master cylinder and from the multiple fitting on the bridge (Fig. 14). Disconnect the three remaining lines from the fitting.

4. Remove the two nuts and lock washers that attach the master cylinder to the booster.

5. Remove the bridge and the master cylinder from the vacuum booster.

#### INSTALLATION

1. Before installing the master cylinder, check the distance from the outer end of the push rod to the master cylinder mounting surface at the end of the vacuum cylinder (Fig. 3, Part 2-1). If the push rod dimension is not correct, see "Master Cylinder Push Rod Adjustment," Part 2-1, Section 2.

2. Position the master cylinder over the push rod onto the two studs that are integral with the booster body.

3. Position the bridge and the tail light wire clip (Fig. 13) on the studs. Install, but do not tighten the attaching nuts and lock washers.

4. Connect the hydraulic lines to the multiple fitting.

5. Connect the line from the cylinder to the multiple fitting.

6. Tighten the two master cylinder attaching nuts.

7. Tighten all hydraulic line fittings.

8. Connect the stop light switch wires to the switch.

9. Bleed the brake system. Fill the master cylinder to  $\frac{3}{8}$  inch from the top of the filler opening. Install the filler cap and gasket.

### VACUUM BOOSTER

#### REMOVAL

1. Disconnect the battery ground cable.

2. Remove the master cylinder from the booster.

3. Disconnect the vacuum hose from the booster.

4. If working on a car equipped with an eight-cylinder engine, remove the left valve rocker arm cover to provide clearance when removing the booster.

5. Working from inside the car, remove the bolt that attaches the booster push rod to the brake pedal (Fig. 14).

6. Working from inside the car, remove the five nuts and lock washers that attach the booster to the dash panel.

7. Remove the booster from the dash panel.

#### INSTALLATION

1. Position the booster and mounting bracket on the dash panel (Fig. 14).

2. Secure the booster with the five attaching nuts and lock washers.

3. Lubricate the bushings with engine oil before installation. Connect the push rod to the brake pedal with the bolt and bushing.

4. If working on a car equipped with an eight-cylinder engine, install the left valve rocker arm cover.

5. Connect the vacuum hose to the booster and secure it with a hose clamp.

6. Install the master cylinder as detailed on this page.

7. Connect the battery ground cable.

8. Bleed the hydraulic system and check the operation of the booster.

### BRAKE PEDAL—MANUAL SHIFT TRANSMISSION

#### REMOVAL

1. Back off the clutch pedal over-center spring adjusting nut and disconnect the equalizer rod. Remove the clutch pedal bumper, and the over-center spring bracket from the support bracket.

2. Remove the over-center adjusting nut and bolt. Remove the brake

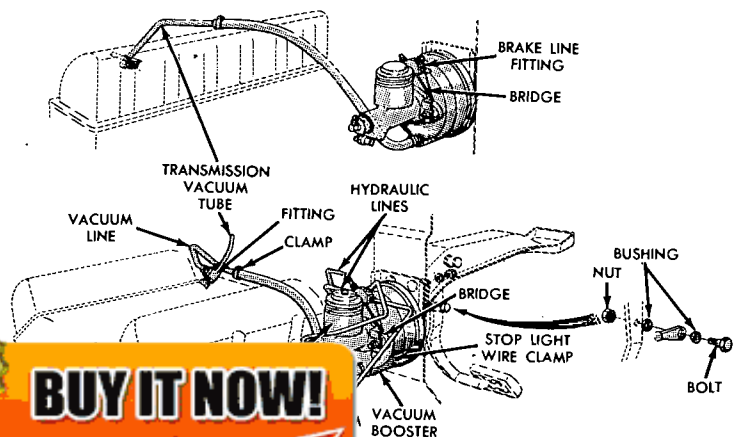

Installation



**BUY IT NOW!**

**Click Here To Order**



push rod, bushings and retaining clip.

3. Remove the clip (Fig. 15) from the clutch and brake pedal shaft and remove the clutch pedal, brake pedal, and bushings.

### INSTALLATION

1. Dip the bushings in engine oil and install them in the brake pedal. Hold the brake pedal in place on the support.

2. Insert the clutch pedal shaft through the brake pedal support bracket, brake pedal, and install the washer retaining clip (Fig. 15).

3. Connect the clutch pedal rod to the clutch pedal, and adjust the free travel.

4. Secure the brake push rod to the pedal with the bushings retaining clip.

5. Connect the clutch link to the release lever. Adjust the over-center spring nut to the correct stud length specifications.

### BRAKE PEDAL—AUTOMATIC TRANSMISSION

#### REMOVAL

1. Remove the retainer clip and bushings from the brake pedal pin and disconnect the brake pedal push rod. If vehicle is equipped with power brakes, remove the nut, bushings, bolt and disconnect the brake pedal push rod.

2. Remove the retaining clip from the end of the brake pedal shaft, and remove the spring washer and nylon thrust washer.

3. Remove the brake pedal shaft. Remove the shaft bushing and remove the pedal.

4. Remove the brake pedal pad and the pedal bumper.

#### INSTALLATION

1. Install the brake pedal pad and the bumper on the pedal assembly.

2. Dip the pedal bushings in engine oil and install them in the brake pedal. Hold the brake pedal in place on the support. Install the brake pedal shaft. Insert the spacer washer.

3. Install the brake pedal shaft nylon washer.

4. Install the nylon bushing, spring washer, and the retaining clip (Fig. 15) on the pedal shaft.

5. Dip the bushings in the push

6. Dip the bushings in the push

7. Dip the bushings in the push

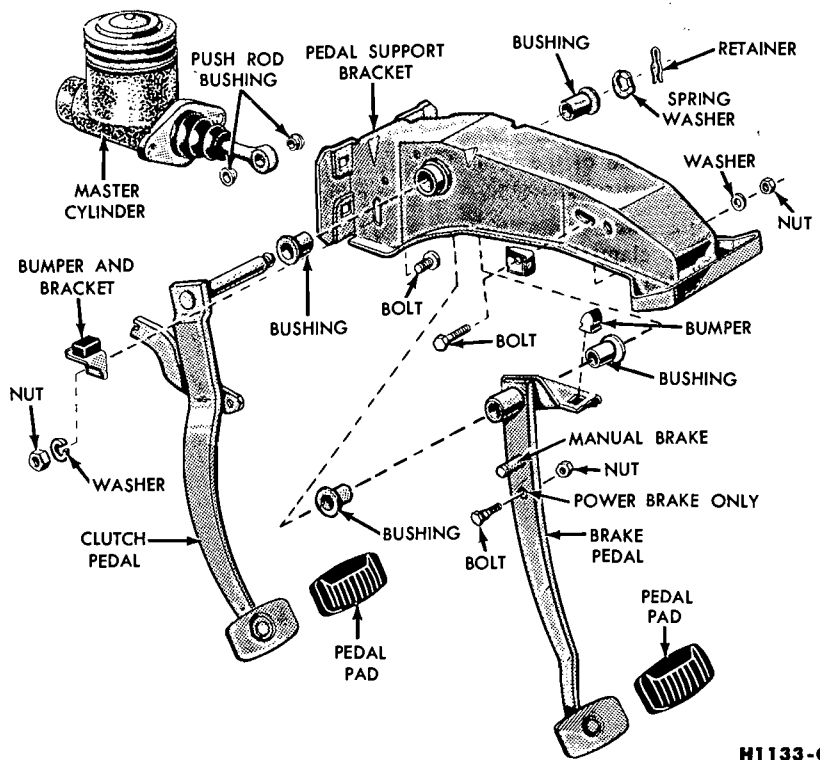

FIG. 15—Brake Pedal and Related Parts

### PARKING BRAKE HANDLE

#### REMOVAL

1. Remove the two screws that hold the handle bracket on the instrument panel. Remove the two screws that secure the cable clamp to the dash panel.

2. Remove the two nuts and lock washers that secure the control to the dash panel.

3. Remove the clevis pin that secures the pulley to the control handle assembly.

4. Disengage the locking rod and remove the ball on the cable from the slot in the control assembly.

#### INSTALLATION

1. Disengage the locking rod and connect the ball end of the cable to the slot on the control assembly.

2. Assemble the pulley to the control handle and the clevis pin.

3. Position the assembly against the dash panel and instrument panel. Secure the assembly to the instrument panel with the two screws.

4. Secure the cable and clamp to dash panel with two screws.

5. Working from under the left front fender, install the two lock washers and attaching nuts.

### PARKING BRAKE EQUALIZER TO HANDLE CABLE

#### REMOVAL

1. Remove the two screws that attach the cable clamp to the dash panel.

2. Remove the parking brake handle assembly.

3. Disengage the locking rod and remove the ball on the cable from the slot in the control assembly.

4. Push the cable down through the hole in the dash panel.

5. From the underside of the car, remove the cable and housing from the holes in the left front side member. If working on a convertible remove the cable from the bracket.

6. Remove the horseshoe-type clip and remove the cable from the hole in the frame crossmember or torque box on convertibles.

7. Loosen the adjusting nut on the equalizer bar and remove the cable.

#### INSTALLATION

1. Thread the cable through the crossmember or torque box on convertibles and install the hairpin clip. Attach the rear of the cable to the equalizer bar.

2. Thread the forward end of the cable and housing through the two

100% GUARANTEED

**BUY IT NOW!**

Click Here To Order

PayPal American Express Discover/Novus MasterCard VISA

holes in the left front side member or bracket on convertibles.

3. Insert the cable and housing through the hole in the dash panel.

4. Disengage the locking rod and connect the ball end of the cable to the slot in the control assembly.

5. Install the two screws that retain the cable clamp to the dash panel and tighten.

6. Install the parking brake handle.

7. Adjust the parking brake at one notch to stop the forward rotation of the rear wheels.

8. Release the handle.

### PARKING BRAKE EQUALIZER TO REAR WHEEL CABLE

#### REMOVAL

1. Disconnect the parking brake equalizer rod from the equalizer lever.

2. Remove the clips from the cable guide brackets on the floor pan.

3. Remove the parking brake cable and housing from the clamp type brackets.

4. Back off the adjustments on the rear brake shoes.

5. Remove both rear hub caps, wheel and tire assemblies, and the rear brake drums.

6. Disconnect the parking brake housings from the backing plates.

7. Disconnect the parking brake cable from the brake shoe lever, and remove the cable and housing from the car.

8. Remove the cable equalizer and the equalizer rod from the parking brake cable.

#### INSTALLATION

1. Install the cable equalizer and the equalizer rod on the cable.

2. Install the ends of the cable through the holes in the backing plates and connect the brake shoe levers.

3. Connect the parking brake housings to the backing plate.

4. Install the rear drums, wheel and tire assemblies, and hub caps.

5. Install the cable and housing in the clamp type brackets.

6. Install the cable in the guide brackets on the floor pan and insert the cotter pins.

7. Attach the parking brake equalizer rod to the equalizer lever.

8. Adjust the rear brake shoes, and then adjust the equalizer rod to three notches to stop the forward rotation of the rear wheels.

9. Release the handle.

## 4 MAJOR REPAIR OPERATIONS

### BRAKE DRUM REFINISHING

The 6-cylinder models are equipped with 9-inch brake drums and the 8-cylinder are equipped with 10-inch drums.

Minor scores on a brake drum can be removed with a fine emery cloth. A drum that is excessively scored or shows a total indicator runout of over 0.007 inch should be turned down. Remove only enough stock to eliminate the scores and true up the drum. The refinished diameter must not exceed 0.060 inch oversize.

If the drum diameter is less than 0.030 inch oversize, 9.030 inches 6-cylinder, or 10.030 inches 8-cylinder after refinishing, standard lining may be installed. If the drum diameter is more than 9.030 inches or 10.030 inches, oversize linings must be installed.

After a drum is turned down, wipe the refinished surface with a cloth soaked in clean denatured alcohol. If one drum is turned down, the opposite drum on the same axle should also be cut down to the same size.

### BRAKE SHOE RELINING

Brake linings that are worn to within  $\frac{1}{32}$  inch of any rivet or have been saturated with grease or oil should be replaced. Failure to replace worn linings will result in a scored drum. **When it is necessary to replace linings, they must also be replaced on the wheel on the opposite side of the car.**

Inspect brake shoes for distortion, cracks, or looseness. If this condition exists, the shoe should be discarded. **Do not repair a defective brake shoe.**

1. Wash the brake shoes thoroughly in a clean solvent. Remove all burrs or rough spots from the shoes.

2. Check the inside diameter of the brake drum. If the diameter is less than 9.030 or 10.030 inches, standard lining may be installed. If the diameter is 9.030 to 9.060 or 10.030 to 10.060 inches, oversize lining should be installed.

3. Position the new lining on the shoe. Starting in the center, insert and secure the rivets, working alternately towards each end. Install all parts supplied in the kit. **Genuine replacement linings are ground**

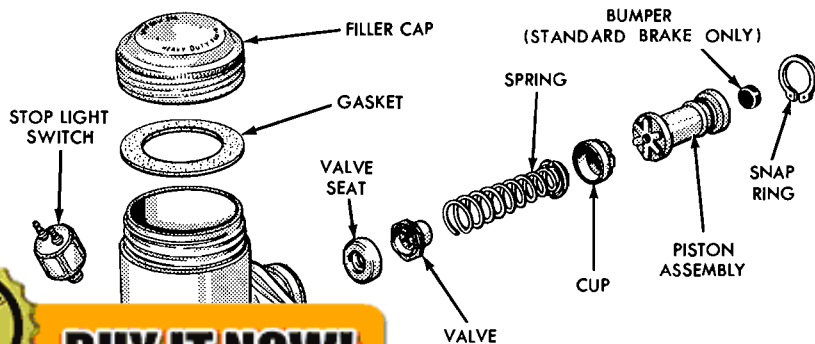

**BUY IT NOW!**

Click Here To Order



assembled

H1132-E

and no further grinding is required.

4. Check the clearance between the shoe and lining. The lining must seat tightly against the shoe with not more than .005 inch clearance between any two rivets.

### MASTER CYLINDER DISASSEMBLY

1. Clean the outside of the cylinder, and remove the filler cap and gasket. Pour out any remaining fluid.

2. Remove the stop light switch, brake fitting, and gaskets (Fig. 16).

3. Remove the snap ring from the push rod end of the cylinder.

4. Remove the piston, cup, spring, valve assembly, and valve seat.

5. Remove the rubber bumper from the piston.

### MASTER CYLINDER ASSEMBLY

1. Dip all parts except the cylinder body in clean **heavy-duty** brake fluid.

2. Install the brake fitting (Fig. 16) on the forward end of the cylinder.

3. Thread the stop light switch into the cylinder and tighten it securely.

4. Insert the valve seat, valve and spring assembly, cup, and piston into the cylinder bore.

5. Compress the piston against the valve spring and install the snap ring.

6. Install the rubber bumper in the piston (standard brakes only).

### MASTER CYLINDER INSPECTION AND REPAIR

1. Clean all parts in clean denatured alcohol and inspect the parts for wear or damage, replacing them as required. When using a master cylinder repair kit, install all of the parts supplied.

2. Check all openings to be sure they are open and free from foreign matter.

the spring valve at the

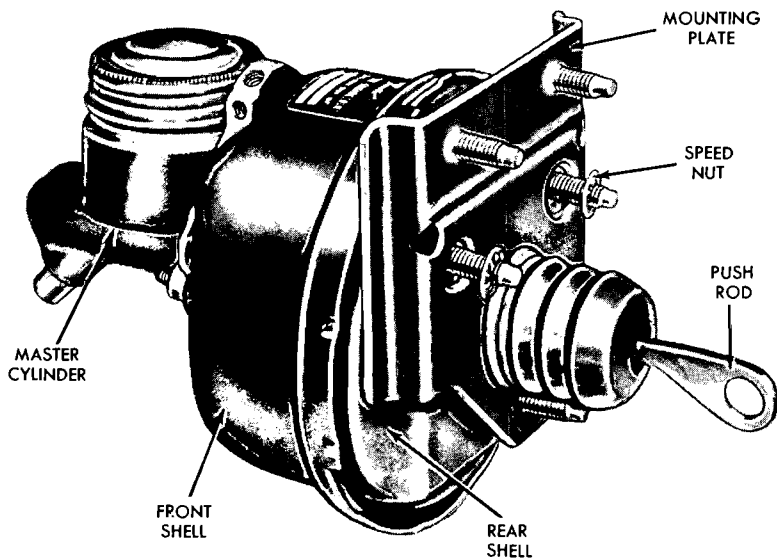

H1333-A

**FIG. 17—Vacuum Booster**

tion is present, the cylinder should be honed. When honing, **do not remove more than 0.003 inch as oversize parts are not available.**

5. Remove any burrs or loose metal that may have resulted from honing. Then clean the cylinder with denatured alcohol.

### DISASSEMBLY OF BOOSTER

1. Remove the speed nuts that attach the mounting plate (Fig. 17) to the rear shell and remove the plate.

2. Pull the push rod and front seal (Fig. 18) from the front shell.

3. Scribe an index mark across the front and rear shells.

4. Place the booster in a vise as shown in Fig. 20. Press downward on the rear shell and at the same time, turn it counterclockwise with a flat bar to release it from the front shell. Release the pressure on the rear shell slowly to prevent the diaphragm plate return spring from flying out.

5. Separate the two shells and remove the return spring.

6. Withdraw the diaphragm plate and diaphragm from the front shell.

7. Remove the diaphragm from the diaphragm plate as shown in Fig. 21.

8. Pry the filter retainer off the

diaphragm plate being careful not to chip or damage the plate.

9. Hold the diaphragm plate so that the valve retainer is facing downward. Press the valve push rod inward to release the tension on the retainer and allow it to drop out of the plate (Fig. 22).

10. Withdraw the valve and rod from the plate.

11. Press the reaction disc out of the diaphragm plate.

12. Pry the seal retainer (Fig. 19) out of the rear shell.

13. Lift the bearing and the seal from the rear shell.

14. Working from the inside of the front shell, cut the bead off the check valve grommet. Remove the check valve.

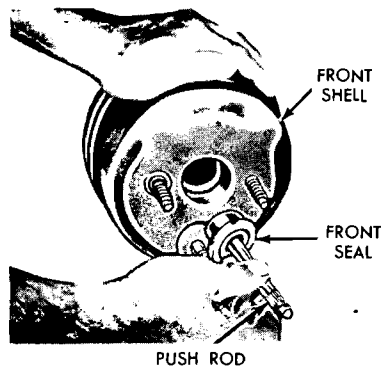

H1334-A

**FIG. 18—Removing Front Seal and Push Rod**

100% SATISFACTION GUARANTEED

**BUY IT NOW!**

Click Here To Order

PayPal American Express Discover NetSpend MasterCard VISA

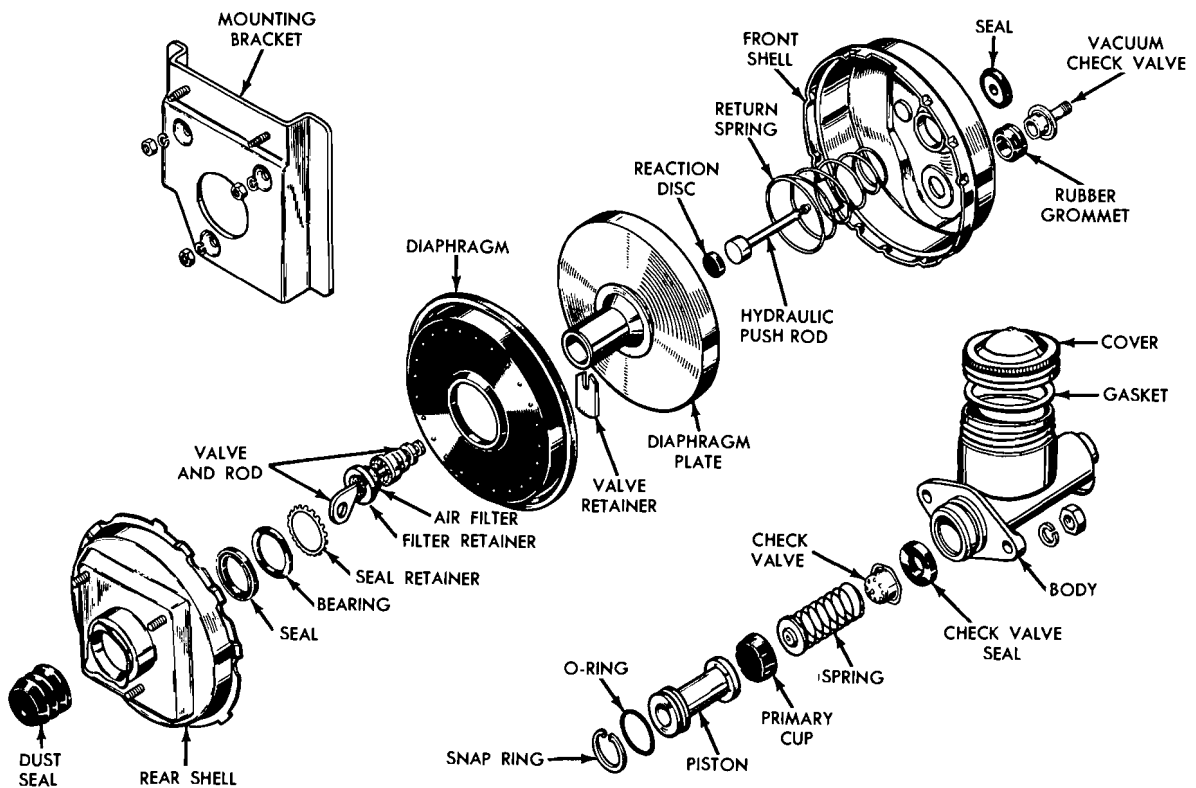

H1322-A

**FIG. 19—Vacuum Booster Disassembled**

**CLEANING AND INSPECTION**

After disassembly, immerse all metal parts in cleaning solvent. Plastic parts should be cleaned **only** in alcohol. Care should be taken to prevent chipping of/or damage to plastic parts. All rubber parts should be replaced. After parts have been thoroughly cleaned, those parts which come in contact with brake fluid should be rewashed in clean alcohol before reassembly. Use an air hose to blow out dirt and cleaning solvent

Position a new seal with the lip facing down and the bearing in the shell. Press the seal retainer into the shell to a depth of  $\frac{1}{4}$  inch.

2. Dip a new check valve grommet (Fig. 19) in alcohol and install it in the front shell making sure that the beveled edge is toward the inside. Make sure that the grommet is seated. Dip the shoulder of the check

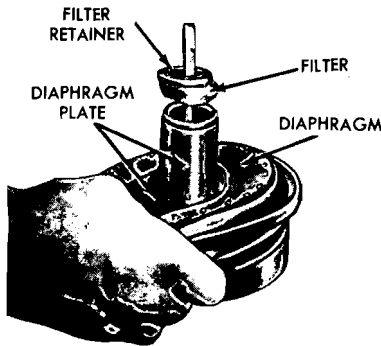

H1336-A

**FIG. 21—Removing Diaphragm**

from recesses and internal passages. When overhauling a vacuum booster use all parts furnished in the repair kit.

**ASSEMBLY OF BOOSTER**

1. Place the rear shell on two wood blocks as shown in Fig. 23.

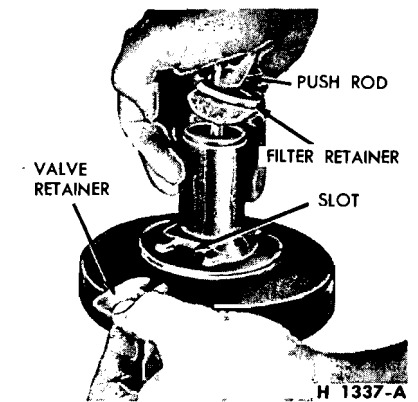

H 1337-A

**FIG. 22—Removing Valve Retainer**

valve in alcohol and install it in the grommet. Press check valve into grommet until the flange contacts the grommet.

3. Apply silicone grease to the outer surface of the diaphragm plate hub and to the bearing and rubber surfaces of the valve.

4. Insert the valve and rod into the hub of the diaphragm plate. Press it on the rod until the retainer can be slid into the retaining groove.

5. Tuck the filter into place in the plate hub. Press the filter retainer onto the hub being careful not to chip or damage the plastic.

6. Place the rear shell in a vise. Apply silicone lubricant generously to the top outer flange of shell. Apply silicone grease to the bearing and the seal in the rear shell.

7. Carefully guide the valve rod and diaphragm plate hub through

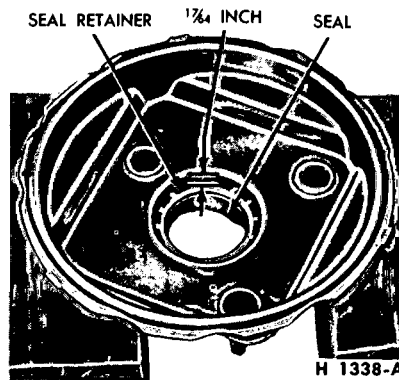

**FIG. 23—Installing Rear Shell Seal**

the bearing and seal in the rear shell.

8. Center the large end of the return spring on the diaphragm plate.

9. Align the index mark on the front shell with the one on the rear

shell. Place a flat bar on the front shell and compress the spring until the tangs on the rear shell contact the diaphragm, then rotate it clockwise to lock it in place.

10. Apply lubricant sparingly to stem of hydraulic push rod keeping it away from the adjusting screw area. Apply silicone grease liberally to the piston area of the push rod and to the reaction disc.

11. Center the reaction disc on the push rod piston. Guide the disc and push rod into base of diaphragm plate and press on the rod to bottom the disc.

12. Press a new seal into front shell until it bottoms in the recess.

13. Install a new dust seal over push rod and onto the rear shell.

14. Position the mounting plate on the rear shell and secure it in place with speed nuts.

**100% SATISFACTION GUARANTEED**

**BUY IT NOW!**

**Click Here To Order**

PayPal   American Express   Discover   MasterCard   VISA

# PART 2-3 SPECIFICATIONS

## TORQUE LIMITS—BRAKES

Description	Foot-Pounds
Brake Cylinder to Brake Backing Plate Bolt	5-7
Hand Brake Control Assembly to Instrument Panel Bolt	8-12
Master Cylinder to Dash Panel Bolt	20-25
Hand Brake Control Assembly to Dash Panel Bolt	8-12
Brake Hose Bolt	12-18
Brake Pedal Support Bracket to Dash Panel Bolt	20-25
Brake Pedal Support Bracket to Instrument Panel Nut	9-13
<b>FRONT BRAKES ONLY</b>	
Wheel Assembly to Wheel Hub and Drum Assembly Nut	55-85
Wheel, Hub and Drum Assembly to Wheel Spindle Nut*	17-25
Backing Plate to Spindle Nut	25-45
<b>REAR BRAKES ONLY</b>	
Axle Housing to Backing Plate Lock Nut	25-35
Drum to Axle Shaft Assembly Speednut	Hand Push Fit
Wheel Assembly to Axle Shaft to Drum Assembly Nut	55-85
Brake Line Connection to Axle Housing Bolt	12-18
Bleeder Screw to Wheel Cylinder	20-45 Inch-Pounds
Master Cylinder Cover	Finger Tight
Master Cylinder Mounting Bolts	20-25
Pedal Pad to Brake Pedal Nut	12-16
Control Assembly—Parking Brake to Cowl Side Bolt	15-19
Master Cylinder Fitting Bolt	30-40
Left Hand Brake Hose—Front to Connector Bolt	12-18
<b>POWER BRAKES</b>	
Vacuum Manifold to Booster Body Mounting Bolt	8-10
Master Cylinder to Booster Body	10-13
Brake Booster to Dash Panel	12-15
Push Rod to Brake Pedal Bolt	10-15

\*.0005 to .0065 Bearing end play at assembly.

## TORQUE LIMITS—BRAKES (Cont'd)

Description	Foot-Pounds
<b>FRONT BRAKES</b>	
Wheel Assembly to Hub and Drum Assembly Nuts	75-110
Brake Backing Plate to Spindle Nuts	25-35
<b>REAR BRAKES</b>	
Drum Assembly to Axle Shaft Assembly Speednut	Hand Push Fit
Wheel Assembly to Axle Shaft to Drum Assembly Nuts	75-110
Brake Cylinder to Brake Backing Plate Bolt	5-7
Brake Backing Plate to Axle Housing	25-35

## DIMENSIONS

Description	
Master Cylinder Bore Diameter	1.000"
Master Cylinder Maximum Allowable Hone	0.003"
Front Wheel Cylinder Bore Diameter: 6-Cylinder Engine 8-Cylinder Engine	1.062" 1.125"
Rear Wheel Cylinder Bore Diameter: 6-Cylinder Engine Sedan and Hardtop Convertibles and Station Wagons 8-Cylinder Engine All Except Station Wagon Station Wagon	0.812" 0.875" 0.906" 0.938"
Wheel Cylinder Maximum Allowable Hone	0.003"
Drum Diameter: 6-Cylinder Engine 8-Cylinder Engine	9.0" 10.0"
Drum Maximum Allowable Run-Out	0.007"
Drum Maximum Boring Diameter: 6-Cylinder Engine 8-Cylinder Engine	9.060" 10.060"



# SUSPENSION, STEERING, WHEELS AND TIRES

# GROUP 3

<b>PART 3-1</b>	<b>PAGE</b>	<b>PART 3-4</b>	<b>PAGE</b>
SUSPENSION, STEERING, WHEELS AND TIRES GENERAL SERVICE .....	<b>3-1</b>	POWER STEERING .....	<b>3-20</b>
<b>PART 3-2</b>		<b>PART 3-5</b>	
SUSPENSION .....	<b>3-8</b>	WHEELS AND TIRES .....	<b>3-28</b>
<b>PART 3-3</b>		<b>PART 3-6</b>	
MANUAL STEERING .....	<b>3-14</b>	SPECIFICATIONS .....	<b>3-30</b>

## PART 3-1 SUSPENSION, STEERING, WHEELS AND TIRES GENERAL SERVICE

<b>Section</b>	<b>Page</b>	<b>Section</b>	<b>Page</b>
1 Diagnosis and Testing .....	3-1	3 Cleaning and Inspection .....	3-7
2 Common Adjustments and Repairs .....	3-5		

### 1 DIAGNOSIS AND TESTING

#### MANUAL STEERING

Table 1 lists various steering gear and linkage trouble symptoms and possible causes. Several of these symptoms are also common to suspension frame, and wheel and tire troubles. For this reason, be sure that the cause of the trouble is in the steering gear or linkage before adjusting, repairing, or replacing any of the steering parts.

#### POWER STEERING

##### PRELIMINARY TESTS

The following preliminary checks should always be made before performing any trouble-shooting operations.

**Check Pump Belt.** If the pump belt is broken, glazed, or worn, replace with a new belt. Use only the specified type of belt.

**Check the belt tension.** If the belt is too loose or too tight, it should be adjusted to the proper ten-

1. Check the power steering belt tension, using tool T62L-8620-A. See Part 3-6 for specified tension on new and on used belts.

2. If necessary, loosen the power steering pump bracket adjusting bolt and the pivot bolt.

3. Increase or decrease tension as required by adjusting the pump position.

4. Torque the adjusting bolt and the pivot bolt to specification, and check the power steering belt tension.

**Check Fluid Level.** Start the engine, turn the steering wheel all the way to the left and right several times, and shut off the engine.

Check the fluid level in the reservoir. If the level is low, add enough fluid to raise the level to a point one inch from the top on remote mounted reservoirs or to the F mark on the dipstick. Do not overfill the reservoir.

##### Check For Fluid Leaks.

1. If the power steering fluid does not already include yellowish green dye, pre-mix one teaspoonful of oil-soluble aniline dye with 2 pints of automatic transmission fluid. Then

refill the reservoir with the dye solution.

2. With the engine running at idle speed, turn the steering wheel all the way to the right stop and to the left stop several times to distribute the dye solution throughout the hydraulic system. Do not hold the wheel against each wheel stop for more than 3 to 5 seconds.

3. Shut off the engine, and check for leaks.

**FITTING AND TUBE SEAT LEAK.** Since most fluid leaks occur at the fittings and connections in a power steering hydraulic system, these parts should be checked before any other part is replaced.

1. With the engine running at idle speed, raise the car on a hoist.

2. Clean the outside of the control valve and the power cylinder, the bottom surfaces of the pump, and all lines and fittings. Dirt, oil, and grease should be removed from all areas where leaks may exist.

3. Tighten all fittings, using a special 5-flat tube wrench. Do not tighten the fittings with a standard open end wrench. If a properly

**100% SATISFACTION GUARANTEED**

**BUY IT NOW!**

**Click Here To Order**

PayPal American Express Discover MasterCard VISA

tightened fitting leaks, replace the seat.

**PUMP, CONTROL VALVE, AND POWER CYLINDER LEAK.** If the fittings and connections do not leak, check the other parts of the system.

**PUMP RESERVOIR LEAKS.** Leak points at the pump reservoir may be caused by improper installation or by a worn or defective cover gasket. A worn or damaged stud gasket on the stud at the center of the cover may also cause leakage.

Check the hose connection at the reservoir for leaks, and tighten the hose clamp if necessary.

**PUMP LEAKS.** Leakage may occur at the O-rings in the orifices at the top of the pump body. The reservoir or pump adapter must be removed from the pump to replace these O-rings. Pump with adapters have only one "O" ring.

Other pump leak points are the shaft seal at the front of the pump, the pump housing O-ring and the other O-ring between the two halves of the pump, and the relief valve retainer O-ring. Replace only the defective parts as required.

**CONTROL VALVE LEAKS.** If the control valve is leaking (somewhere other than the tube seats), replace all the seals, using a control

valve seal kit. Use all the parts in the kit, and be sure they are correctly installed. When assembling the new seals in the valve, an application of silicone grease to the internal parts will help to provide a better seal against future leakage. Apply grease to the centering spring area, especially on the cap and spacer mating surfaces. Coat the threads of the cap retaining bolts with grease. The rubber boot seals, the actuator assembly, and the metal cup seals in the control valve should also be coated with silicone grease.

Some oil remaining from the manufacturing processes may be found in the sleeve near the ball stud. Do not confuse this oil with leaking fluid from the hydraulic system.

**POWER CYLINDER LEAKS.** The power cylinder may leak at the piston rod seals. A power cylinder seal kit should be used to correct leakage. **Do not replace the power cylinder assembly unless the piston rod is scored or has a dull gray finish instead of a high luster chrome finish.**

**Check Turning Effort.** With the front wheels properly aligned and tire pressures correct, check the effort required to turn the steering wheel.

1. With the car on dry concrete, set the parking brakes.

2. With the engine warmed up and running at idle speed, turn the steering wheel to the left and right several times to warm the fluid.

3. Attach a pull scale to the steering wheel (Fig. 1). Check the effort required to turn the wheel at least one complete revolution in both directions. See Part 6-3 for the specified torque which should be approximately equal in both directions.

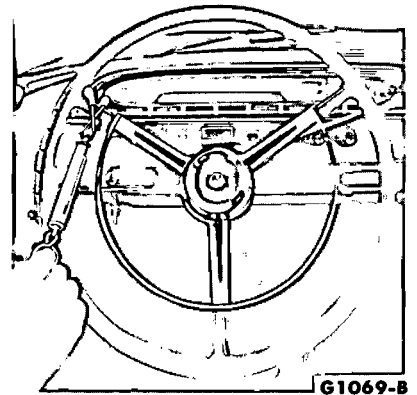

**FIG. 1—Checking Turning Effect—Typical**

**TROUBLE DIAGNOSIS GUIDE**

<p><b>BINDING OR POOR RECOVERY</b></p>	<p>If the steering wheel binds or sticks when turned, or if poor recovery to the straight-ahead position occurs, check the Pitman arm ball stud in the control valve sleeve. If the ball stud is rubbing against the edge of the sleeve slot, the roll pin may be missing.</p> <p>If either of the idler arm bushings is worn or damaged, replace both bushings.</p> <p>Check the steering gear adjustments (Section 2).</p> <p>Check the operation of the control valve spool in the valve housing. If the spool is binding in the housing,</p>	<p>check the spool adjustment. If the adjustment is correct, overhaul or replace the control valve.</p> <p>Check the control valve travel regulator stop adjustment. If the stop is drawn up too tightly, the ball stud will bind in the seats. Adjust the stop as required.</p> <p>Check the control valve sleeve and the socket tube for damage. Replace parts that show signs of damage, and adjust the travel regulator stop.</p> <p>Check for possible interference between the steering wheel and the steering column.</p>
--	--	--

If the effort required to turn the steering wheel is greater than normal for the entire travel of the front wheels, check the tire pressure then, test the fluid pressure. Be sure that there are no leaks, that the reservoir is properly filled, and that the belt is properly adjusted. If the pump output pressure is low, the pump

may be defective and should be overhauled or replaced.

If the pressure test shows that the trouble is in the control valve or power cylinder, remove and inspect these units. Repair or replace any damaged parts.

If the pressure test indicates that the pressures throughout the system

may be defective and should be overhauled or replaced.

If the pressure test shows that the trouble is in the control valve or power cylinder, remove and inspect these units. Repair or replace any damaged parts.

If the pressure test indicates that the pressures throughout the system

**100% SATISFACTION GUARANTEED**

**BUY IT NOW!**

**Click Here To Order**

PayPal American Express Discover Novus MasterCard VISA

TROUBLE DIAGNOSIS GUIDE (Continued)

<p><b>HARD STEERING (Continued)</b></p>	<p>are within specifications, check the following items in the order given:                  Check the control valve spool centering spring adjustment. Adjust if required (Section 3).                  Check the control valve spool for movement. If the spool does not move freely, check for, and eliminate, interference between the socket tube and the valve sleeve. If the spool is sticking in the housing, remove the spool and check the spool</p>	<p>lands for burrs. Small burrs may be removed with crocus cloth if the edges of the valve lands are not rounded in the process. If the spool cannot be repaired, replace the control valve.                  Check the control valve ball stud for free movement in the ball stud seats. If the stud is binding in the seats, adjust the travel regulator stop.                  If the hard steering still persists, check the front end alignment.</p>
<p><b>EXCESSIVE FREE PLAY</b></p>	<p>If excessive free play or lost motion is noticed when steering, check the steering gear worm and ball nut mesh adjustment.                  Check for excessive clearance between the steering arm ball stud and the ball stud seats. If the ball stud is loose in the seats, adjust the con-</p>	<p>trol valve travel regulator stop.                  Check the control valve centering spring adjustment. If the spring adjusting nut is loose, tighten the nut until it is snug, and then back off the nut not more than ¼ turn. <b>Excessive tightening may damage the stop pin.</b></p>
<p><b>NOISE</b></p>	<p>Check the pump belt tension. A loose or glazed belt can cause belt squeal. A glazed belt, even when properly adjusted, may slip.                  Excessive torque at the pressure line joints may distort the tube seats and cause noise.</p>	<p>Noise may result if the specified hose is not used or if it is improperly routed. If noise still exists with the specified hose properly installed and routed, the pump should be removed from the car and inspected.</p>
<p><b>STEERING CHATTER</b></p>	<p>A loose pump belt or air in the fluid can cause chatter against the wheel stops during an extremely sharp turn. Check the belt tension, and adjust it to specifications or fill the reservoir if necessary.                  Check for looseness in the idler arm rod connection. Looseness at this point may be due to worn mounting bushings or improper</p>	<p>mounting nut torque. Replace the bushings if worn. Torque the nut to specification.                  Check the power cylinder piston rod insulators for looseness. If the insulators are worn, replace them. If the mounting nut is loose, torque it to specification, and torque the locknut to specification.</p>
<p><b>RATTLES</b></p>	<p>Check the control valve spool centering spring adjustment. If the adjustment is loose, tighten the nut until snug, and then back off the nut not more than ¼ turn. <b>Excessive tightening may damage the stop</b></p>	<p><b>pin.</b>                  Check for looseness between the control valve ball stud and the ball stud seats. If the stud is loose in the seats, adjust the travel regulator stop.</p>
<p><b>LOSS OF POWER ASSIST</b></p>	<p>Check the entire system for damage, replacing parts as necessary. Tighten a loose pump belt.                  Test the fluid pressure to determine whether the trouble is in the pump, the control valve, or the power cylinder.                  If the pressure test indicates that the pump is at fault, remove and overhaul or replace the pump.                  If the pressure test indicates that the control valve or power cylinder is at fault, check as follows:                  Disconnect the power cylinder piston rod from the idler arm bracket.                  Move the piston by hand to check</p>	<p>for resistance to movement. If the piston moves easily with little or no resistance, the internal parts of the power cylinder are broken or damaged. Replace the power cylinder if broken or damaged.                  Maladjustment of the control valve spool centering spring can cause a loss of either right or left power assist. Check the adjustment, and readjust if necessary. Replace all defective parts.                  Check the operation of the control valve check valve. If the check valve does not operate freely, replace the check valve assembly.</p>

**100% SATISFACTION GUARANTEED**

**BUY IT NOW!**

**Click Here To Order**

PayPal American Express Discover MasterCard VISA

**TABLE 1—Trouble Symptoms and Possible Causes**

TROUBLE SYMPTOMS	POSSIBLE CAUSES OF TROUBLE														
	Jerky Steering	Loose Steering	Hard Steering and/or Loss of Power Assist	Hard Turning When Stationary	Steering and Suspension Noises	Shimmy or Wheel Tramp	Pull to One Side	Side-to-Side Wander	Body Sway or Roll	Tire Squeal on Turns	Binding or Poor Recovery	Abnormal or Irregular Tire Wear	Sag at One Wheel	Hard or Rough Ride	Rear Suspension Misalignment (Dog-Tracking)
1. Incorrect Tire Pressure			X	X		X	X	X	X	X	X	X	X	X	
2. Tire Sizes Not Uniform			X	X			X	X		X		X	X		
3. Overloaded or Unevenly Loaded Vehicle							X	X				X	X	X	
4. Power Steering Fluid Level Low-Leak	X		X	X	X										
5. Sagging or Broken Spring					X		X	X	X			X	X	X	
6. Glazed, Loose or Broken Power Steering Pump Belt	X		X	X	X										
7. Rear Spring Tie Bolt Off Center							X					X			X
8. Broken Rear Spring Tie Bolts					X	X	X	X	X			X			X
9. Rear Spring Front Hanger Mislocated							X					X			X
10. Bent Spindle Arm							X	X		X		X			
11. Bent Spindle							X	X		X		X			
12. Lack of Lubrication			X	X	X						X			X	
13. Air in Power Steering System	X		X		X	X									
14. Obstruction in Power Steering Lines			X	X	X										
15. Loose or Weak Shock Absorber					X	X		X	X			X		X	
16. Loose or Worn Suspension Arm Bushings					X	X						X		X	
17. Binding Front Suspension Ball Joints or Steering Linkage	X		X	X	X						X			X	
18. Loose, Worn, or Damaged Steering Linkage or Connections	X	X			X	X		X		X		X			
19. Loose Steering Gear Mountings	X	X			X	X		X							
20. Insufficient Steering Pump Pressure			X	X							X				
21. Incorrect Steering Gear Adjustment	X	X	X	X	X	X		X	X		X	X			
22. Incorrect Brake Adjustment	X				X		X					X			
23. Incorrect Front Wheel Bearing Adjustment	X	X			X	X	X	X				X			
24. Wheel Out of Balance	X					X						X		X	
25. Incorrect Front Wheel Alignment			X		X	X	X		X	X	X	X			
26. Out-of-Round Wheel or Brake Drum						X						X		X	
27. Front Wheel or Underbody Out of Alignment							X					X			X
28. Steering Gear Adjustment					X		X				X				X
29. Obstruction in Steering Gear	X		X	X			X				X				

**100% SATISFACTORY GUARANTEED**

**BUY IT NOW!**

**Click Here To Order**

For: Obstruction in Steering Gear

### FLUID PRESSURE TEST

A fluid pressure test will show whether the pump or some other unit in the power steering system is causing trouble in the system.

1. Disconnect the pressure line hose from the pump outlet, and install the pressure testing tool between the hose and the pump outlet (Fig. 2). Be sure that the pressure gauge is between the pump and the shut-off valve on the tool.

2. Open the shut-off valve on the testing tool, and run the engine at idle speed. If the pump normally operates quietly, ignore the louder pump noise when the pressure testing tool is connected to the system. Allow at least two minutes for the fluid to warm up before starting the pressure tests.

3. Turn the front wheels all the way to the right and then to the left, noting the fluid pressure reading on the gauge when each wheel is against its stop.

Normal pressure is 750-900 psi. Do not hold a wheel against its stop for more than three to five seconds at a time because the fluid may overheat.

4. If the fluid pressure, with a wheel against its stop, is less than 750 psi turn the wheel off the stop. Slowly close the testing tool shut-off valve, and watch the gauge for an

increase in pressure. Do not leave the valve closed for more than three to five seconds.

5. If the fluid pressure, with the shut-off valve fully closed, still shows less than 750 psi, the pump is causing the trouble. If the pressure increases to normal pressure range, the

trouble is in either the control valve or power cylinder.

6. After the fluid pressure test is complete, shut off the engine and remove the pressure testing tool. Make the necessary repairs or replacements to eliminate the trouble in the system.

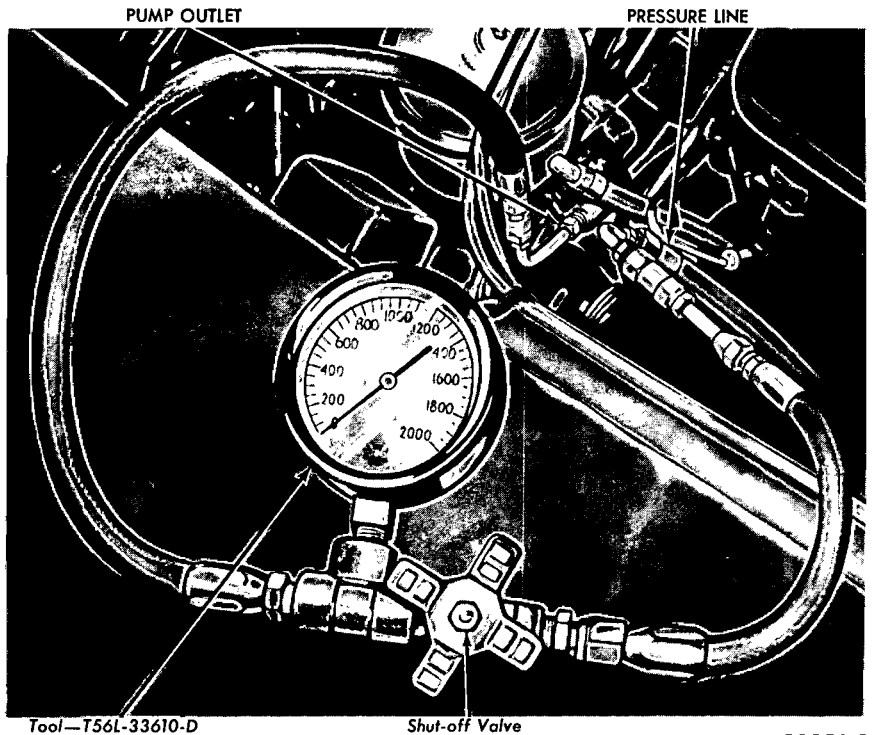

FIG. 2—Pressure Testing Tool Installed

## 2 COMMON ADJUSTMENTS AND REPAIRS

### FRONT WHEEL ALIGNMENT CHECKS

Do not attempt to check and adjust front wheel alignment without first making a preliminary inspection of the front-end parts.

Check all the factors of front wheel alignment except toe-out on turns before making any adjustments. Toe-out on turns should be checked only after caster, camber, and toe-in have been adjusted to specifications.

### EQUIPMENT INSTALLATION

Equipment used for front wheel

ahead position of the front wheels, and then mark the steering wheel hub and the steering column collar (Fig. 3). Do not adjust the steering wheel spoke position at this time. If the front wheels are turned at any time during the inspection, align the marks to bring the wheels back to the straight-ahead position.

2. Install the wheel alignment equipment on the car. Whichever type of equipment is used, follow the installation and inspection instructions provided by the equipment manufacturer.

### CASTER

Check the caster angle at each front wheel.

Caster is the forward or rearward of the top of the wheel spindle. If the spindle tilts to the rear, caster

is positive. If the spindle tilts to the front, caster is negative. The correct caster angle, or tilt, is  $\frac{1}{2}^\circ \pm \frac{1}{2}^\circ$ . The maximum difference between

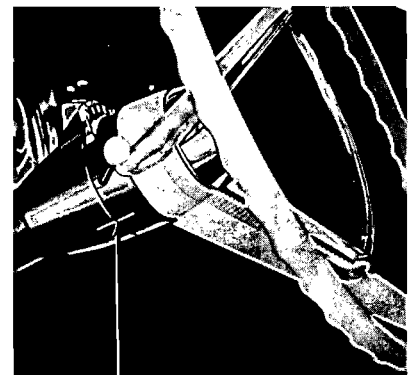

FIG. 3—Straight Ahead Position Marks—Typical

100% SATISFACTION GUARANTEED

**BUY IT NOW!**

Click Here To Order

for enough to establish the straight-

PayPal American Express Discover Novus MasterCard VISA

both front wheel caster angles should not exceed  $\frac{1}{2}^\circ$ . However, a difference of not more than  $\frac{1}{4}^\circ$  is preferred.

### CAMBER

Check the camber angle at each front wheel.

Camber is the amount the front wheels are tilted at the top. If a wheel tilts outward, camber is positive. If a wheel tilts inward, camber is negative. The correct camber angle, or outward (positive) tilt, is  $+1\frac{1}{2}^\circ \pm \frac{1}{2}^\circ$ . The maximum difference between both front wheel camber angles should not exceed  $\frac{1}{2}^\circ$ . However, a difference of not more than  $\frac{1}{4}^\circ$  is preferred.

### TOE-IN

Check the toe-in with the front wheels in the straight-ahead position. **Run the engine so that the power steering control valve will be in the center (neutral) position.** Measure the distance between the extreme front and also between the extreme rear of both front wheels. The difference between these two distances is the toe-in.

Correct toe-in, or inward pointing of both front wheels at the front, is  $\frac{1}{4}$ - $\frac{3}{16}$  inch.

### Front Wheel Turning Angle

Six-cylinder — The turning angle of an outside wheel should be  $20^\circ\frac{3}{4}'$  with P/S and  $19^\circ$  with manual steering when the inside wheel is turned  $20^\circ$ .

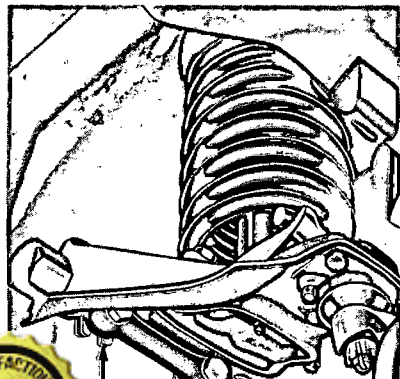

Eight-cylinder — The turning angle of an outside wheel should be  $19^\circ$  when the inside wheel is turned  $20^\circ$ .

After front wheel alignment factors have been checked, make the necessary adjustments. **Do not attempt to adjust the front wheel alignment by bending the suspension or steering parts.**

### CASTER AND CAMBER ADJUSTMENTS

Caster and camber can be adjusted by removing or installing shims between the inner shaft of the front suspension upper arm and the underbody (Fig. 4).

Both caster and camber adjustments can be made at the same time by loosening the nuts on the two bolts that fasten the inner shaft to the underbody. After the required shims have been removed or installed, torque the nuts to specification. Caster and camber adjusting shims are available in  $\frac{1}{32}$ -inch and  $\frac{1}{8}$ -inch thickness.

The  $\frac{1}{32}$  inch shims should be placed against the fender housing sheet metal or between the  $\frac{1}{8}$  inch shims.

### CASTER

To adjust caster, remove or install shims at either the front bolt or the rear bolt (Fig. 4).

The removal of shims at the front bolt or the installation of shims at the rear bolt will cause the upper ball joint to move forward. The removal of shims at the rear bolt or the installation of shims at the front bolt will cause the ball joint to move rearward. A  $\frac{1}{32}$ -inch change of shim thickness at either bolt will change the caster angle approximately  $\frac{1}{2}^\circ$ . The difference between the shim

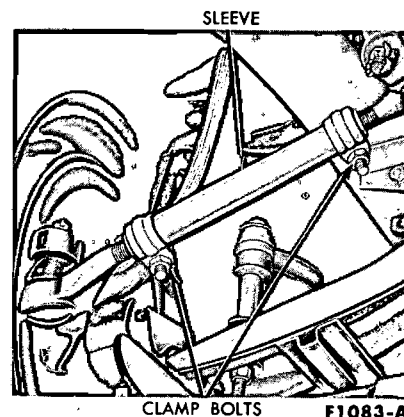

**FIG. 5—Spindle Connecting Rod Sleeve**

stack thickness at the two bolts should not exceed  $\frac{1}{16}$  inch (Fig. 4).

### CAMBER

To adjust camber, remove or install equal shim thicknesses at both bolts (Fig. 4).

The removal of equal shims at both bolts will move the upper ball joint inward. The installation of equal shims at both bolts will move the ball joint outward. A  $\frac{1}{16}$ -inch change of shim thickness at both bolts will change the camber angle  $\frac{1}{8}^\circ$ . The total shim stack thickness at each bolt should not exceed  $\frac{9}{16}$ -inch (Fig. 4).

### TOE-IN AND STEERING WHEEL ALIGNMENT ADJUSTMENTS

Check the steering wheel spoke position when the front wheels are in the straight-ahead position. If the spokes are not in their normal position, they can be properly adjusted while toe-in is being adjusted.

1. Loosen the two clamp bolts on each spindle connecting rod sleeve (Fig. 5).

2. Adjust toe-in. If the steering wheel spokes are in their normal position, lengthen or shorten both rods

TURN DOWNWARD TO INCREASE ROD LENGTH

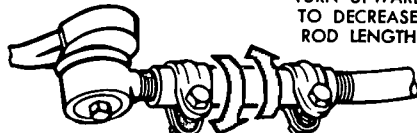

LEFT-HAND SLEEVE

TURN UPWARD TO DECREASE ROD LENGTH

TURN DOWNWARD TO DECREASE ROD LENGTH

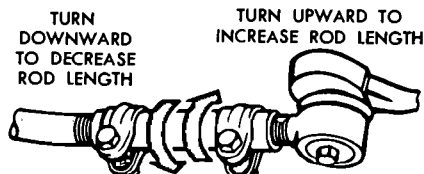

RIGHT-HAND SLEEVE

F1037-B

**FIG. 6—Spindle Connecting Rod Adjustment**

**100% SATISFACTION GUARANTEED**

**BUY IT NOW!**

**Click Here To Order**

PayPal, American Express, Discover, MasterCard, VISA

equally to obtain correct toe-in (Fig. 6). If the steering wheel spokes are not in their normal position, make the necessary rod adjustments to obtain correct toe-in and steering wheel spoke alignment (Fig. 7).

3. Recheck toe-in and steering wheel spoke alignment. If toe-in is

correct and the steering wheel spokes are still not in their normal position, turn both connecting rod sleeves upward or downward the same number of turns to move the steering wheel spokes (Fig. 7).

4. When toe-in and steering wheel spoke alignment are both correct

torque the clamp bolts on both connecting rod sleeves to specification. **The sleeve position should not be changed when the clamp bolts are tightened.**

### LUBRICANT CHECKING PROCEDURE

1. Center the steering wheel.
2. Remove the steering gear housing filler plug.
3. Remove the **upper** cover-to-housing attaching bolt.
4. With a clean punch or like instrument, clean out or push inward the loose lubricant in the filler plug hole and cover to housing attaching bolt hole.
5. Slowly turn the steering wheel to the **right** stop, lubricant should rise within the **upper** cover bolt hole; then slowly turn the steering wheel to the **left** stop, lubricant should rise within the filler plug hole. If lubricant does not rise in both the cover bolt hole and the filler plug hole, add lubricant until it comes out both holes during this check.
6. Install the upper cover-to-housing attaching bolt.

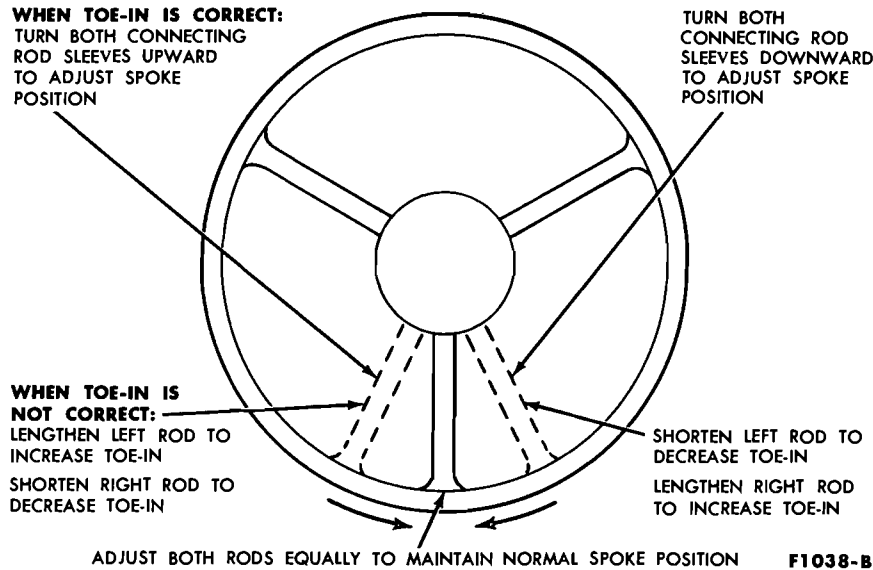

FIG. 7—Toe In and Steering Wheel Spoke Alignment Adjustment

## ③ CLEANING AND INSPECTION

### STEERING GEAR CLEANING AND INSPECTION

Wash all parts in a cleaning solvent, dry with a lint-free cloth. **The bearing should not be spun dry with compressed air.** Inspect the shaft and worm for scoring, cracks or checks, and for straightness of the shaft. Check the splines and the threads on the sector shaft for wear and burrs. Inspect the gear teeth for scoring, pitting and other wear. Inspect the ball bearings for free movement, and the cups for wear or irregular surfaces. Check the housing for cracks and the sector shaft needle bearing for free movement or other wear.

1. Check for specified air pressures in all four tires.

2. Raise the front of the car off the floor. Shake each front wheel grasping the upper and lower surfaces of the tire to check the front suspension ball joints and mountings for looseness, wear, and damage. Check the brake backing plate mountings. Torque all loose nuts and bolts to specifications. Replace all worn parts as outlined in Part 3-2.

3. Check the steering gear mountings and all steering linkage connections for looseness. Torque all mountings to specifications. If any of the linkage is worn or bent, replace the parts as outlined in Part 3-3.

4. Check the front wheel bearings. If any in-and-out free play is noticed, adjust the bearings to specification (Part 3-6). Replace worn or damaged bearings as outlined in Part 3-4.

5. Spin each front wheel with a wheel spinner, and check and balance each wheel as required.

6. Check the action of the shock absorbers. If the shock absorbers are not in good condition, the car may not settle in a normal, level position, and front wheel alignment may be affected.

### WHEEL INSPECTION

Wheel hub nuts should be tightened to specification at the pre-delivery inspection. Loose wheel hub nuts may cause shimmy and vibration. Elongated stud holes in the wheels may also result from loose hub nuts.

Keep the wheels and hubs clean. Stones wedged between the wheel and drum and lumps of mud or grease can unbalance a wheel and tire.

Check for damage that would affect the runout of the wheels. Wobble or shimmy caused by a damaged wheel will cause premature tire wear and eventually damage the wheel bearings. Inspect the wheel rims for dents that could permit air to leak from the tires.

100% SATISFACTION GUARANTEED

**BUY IT NOW!**

Click Here To Order

PayPal American Express Discover/Novus MasterCard VISA

# PART 3-2 SUSPENSION

<b>Section</b>	<b>Page</b>
1 Description and Operation .....	3-8
2 In-Car Adjustments and Repairs .....	3-9
3 Removal and Installation .....	3-9

## 1 DESCRIPTION AND OPERATION

### FRONT SUSPENSION

Each front wheel rotates on a spindle. The upper and lower ends of the spindle are attached to upper and lower ball joints which are mounted to an upper and lower arm respectively. The upper arm pivots on a bushing and shaft assembly which is bolted to the underbody. The lower arm pivots on a bolt that is located in an underbody bracket (Fig. 1).

A coil spring seats between the upper arm and the top of the spring housing. A double acting shock absorber is bolted to the arm and the top of the spring housing.

The swiveling action of the ball joints allows the wheel and spindle assemblies to move up and down with changes in road surface. The swiveling ball joints also permit the spindles and wheels to be turned to the left or right by the steering gear and linkage.

The pivoting action of the suspension arms provides an up and down movement for the spindles and wheels as required by bumps or depressions in the road surface. The coil springs, shock absorbers and stabilizer bar control the front suspension up and down movements. The struts, which are connected between the suspension lower arms and the underbody prevent the suspension arms from moving forward and backward.

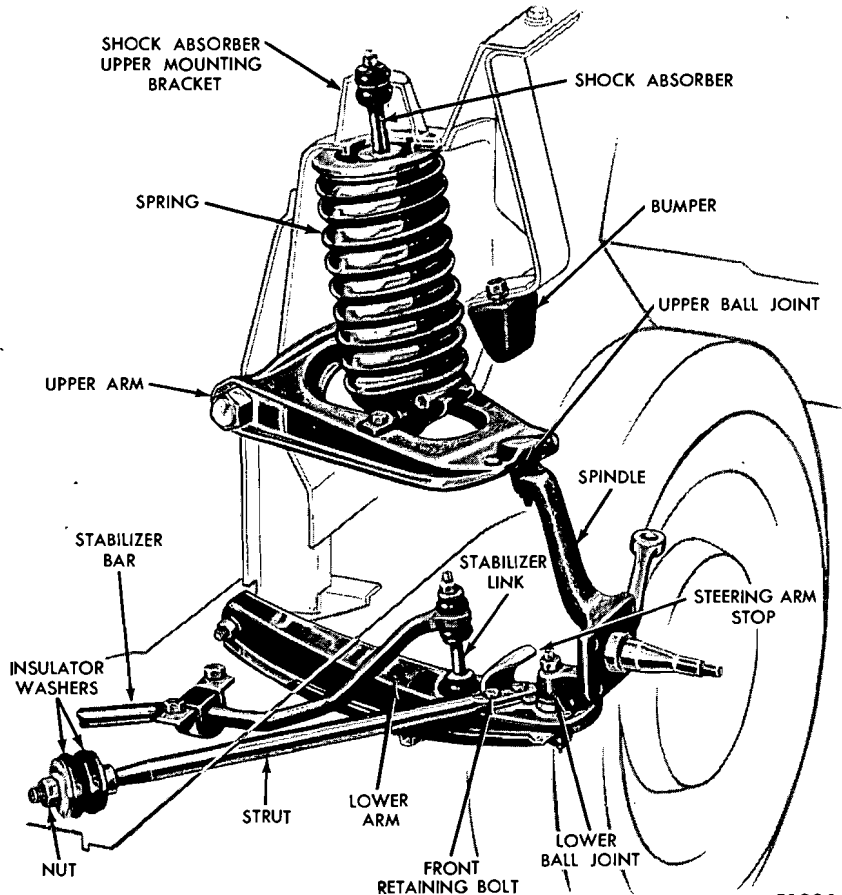

FIG. 1—Front Suspension

### REAR SUSPENSION

Each rear wheel, hub and brake drum assembly is bolted to the rear axle shaft flange. The wheel and axle shaft assembly rotates in the rear axle housing. Two spring pads integral with the axle housing, rest on leaf type springs. The axle hous-

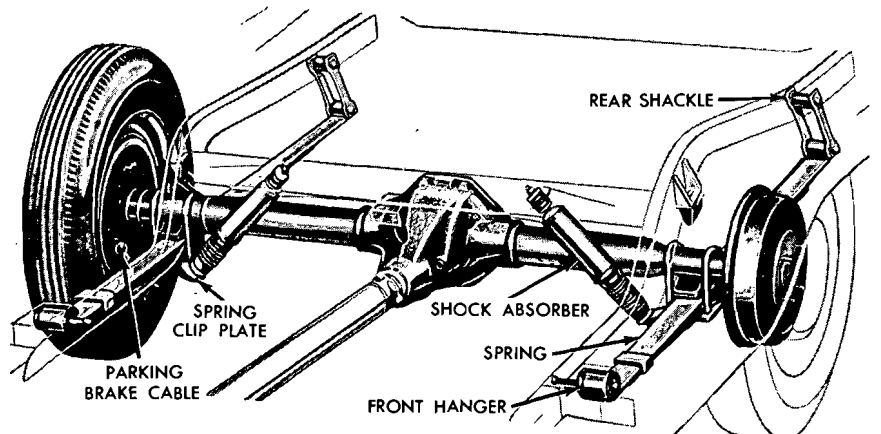

FIG. 2—Rear Suspension

**100% SATISFACTION GUARANTEED**

**BUY IT NOW!**

**Click Here To Order**

PayPal, American Express, Discover, MasterCard, VISA

to a bracket in the underbody. The lower end is mounted to the spring pad at the axle housing.

The springs and shock absorbers provide for up and down movement of the rear axle and wheels as re-

quired by changes in the road surface. They also cushion road shocks.

## 2 IN-CAR ADJUSTMENTS AND REPAIRS

### FRONT SUSPENSION

#### UPPER BALL JOINT REPLACEMENT—ARM IN CAR

1. Position a support between the upper arm and frame side rail as shown in Fig. 3, then raise the car and position safety stands.
2. Remove the wheel and tire.
3. Using a large chisel, cut off the three upper ball joint retaining rivets.
4. Remove the cotter pin and nut from the upper ball joint stud.
5. Position the ball joint remover tool as shown in Fig. 4. The tool should seat firmly against the ends of both studs, and not against the lower stud nut. It may be necessary to remove the lower ball joint cotter pin if it prevents the tool from seat-

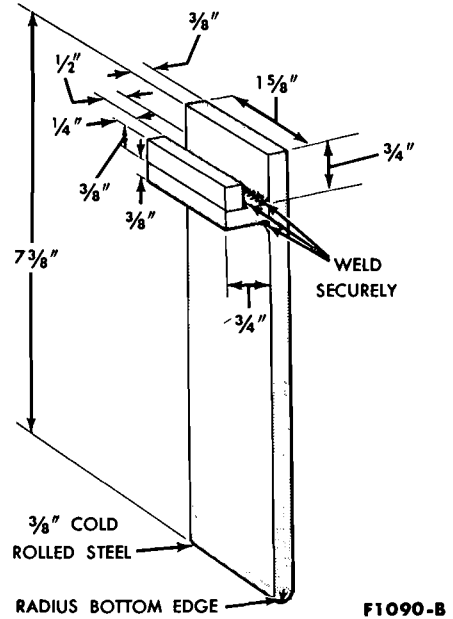
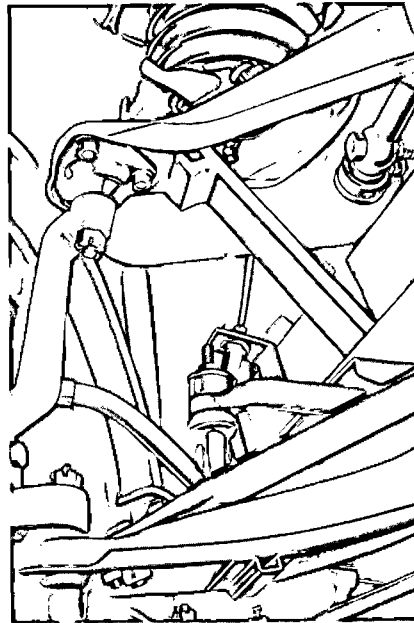

FIG. 3—Upper Arm Support

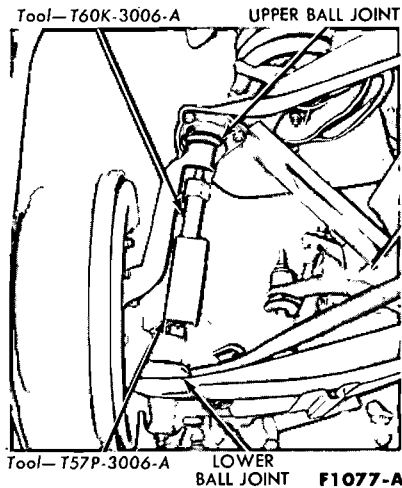

FIG. 4—Locking Upper Ball Joint Stud in Spindle

ing on the lower stud.

6. Turn the tool with a wrench until both studs are under tension, and then, with a hammer, tap the spindle near the upper stud to loosen the stud from the spindle. Do not loosen the stud with tool pressure alone. Remove the ball joint.

7. Clean the end of the arm, and remove all burrs from the hole edges. Check for cracks in the metal at the holes, and replace the arm if it is cracked.

8. Attach the new ball point to the upper arm. Use only the specified bolts, nuts, and washers. Do not

rivet the new ball joint to the arm. Torque the nuts to specification.

9. Position the ball joint stud in the spindle bore, and torque the retaining nut to specification. Install a new cotter pin, tighten the nut if necessary to line up the cotter pin hole.

10. Lubricate the ball joint, and install the wheel and tire.

11. Remove the safety stands, and lower the car.

12. Remove the support from between the upper arm and frame.

13. Check and, if necessary, adjust caster, camber, and toe-in.

### REMOVAL AND INSTALLATION

**100% SATISFACTION GUARANTEED**

**BUY IT NOW!**

**Click Here To Order**

PayPal, American Express, Discover, MasterCard, VISA

upper arm and frame as shown in Fig. 3.

2. Raise the car and remove the wheel and tire as an assembly.

Remove the shock absorber

lower retaining nuts.

4. Remove the shock absorber upper mounting bracket retaining bolts and remove the bracket and shock absorber (Fig. 7).

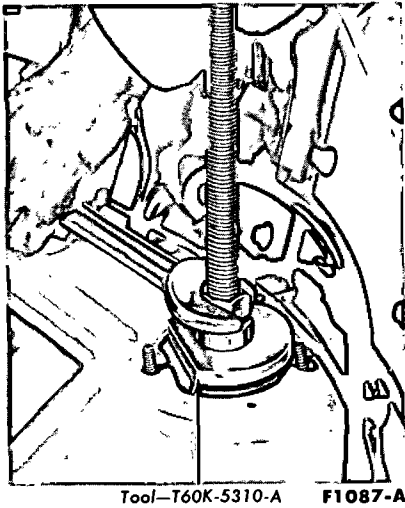

**FIG. 5—Removing Coil Spring**

5. Install a safety stand at the front end of the underbody.

6. Install the tool shown (Fig. 5) through the top of the spring housing so that the tool lower studs fit into the shock absorber lower mounting holes, and secure the tool to the spring seat with two nuts.

7. Fit the tool pilot into the spring upper seat, then compress the spring by tightening the nut on the threaded shaft of the tool. Tighten the nut until the spring is loose in its housing.

8. Remove the spring lower seat attaching nuts, then lift the assembly to disengage the spring seat from the suspension arm.

9. Guide the spring and tool down and out the forward end of the wheelhousing.

#### Installation

1. If the spring is to be replaced, measure the spring height compressed in the tool. Place the tool nut in a vise and rotate the assembly by hand until the spring is decompressed (Fig. 6).

2. Transfer the tool to the new spring. Be sure that the pilot of the tool fits into the spring upper seat and that the spring coil is firmly seated in both grooves of the spring lower seat.

Place the tool nut in a vise, and

is to the outboard side.

5. Install the spring lower seat to suspension arm retaining nuts.

6. Loosen the spring removal tool nut until the spring is properly seated, and then remove the tool (Fig. 5).

7. Install the shock absorber.

8. Install the wheel and tire assembly, remove the safety stand, and lower the car.

9. Remove the support from between the upper arm and frame.

#### UPPER ARM REPLACEMENT

##### Removal

1. Remove the front spring as outlined under "Removal" in the foregoing procedure.

2. Position a safety stand under the lower arm.

3. Remove the cotter pin from the nut on the upper ball joint stud, and loosen the nut one or two turns. **Do not remove the nut from the stud at this time.**

4. Position the ball joint remover tool, and install the tool shown in Fig. 4 between the upper and lower ball joint studs. **The tool should seat firmly against the ends of both studs and not against the stud nuts.**

5. Turn the tool with a wrench until the tool places the studs under tension, and then tap the spindle near the upper stud with a hammer to loosen the stud in the spindle. **Do not loosen the stud in the spindle with tool pressure only.** If both arms are being removed, loosen the lower stud in the same manner as the upper stud.

6. Remove the nut from the upper stud and lift the stud out of the spindle.

7. Remove the upper arm inner shaft retaining nuts from the engine compartment, and remove the upper arm. Measure and note the total shim thickness at each inner shaft bolt.

8. Wipe off all loose dirt from the upper arm parts. **Do not wash the ball joint with a solvent.**

##### Installation

1. Position the upper arm on the underbody mounting bracket, and install but do not tighten the nuts and lockwashers on the two inner shaft retaining bolts. **The specified key-stone-type lockwashers must be used.**

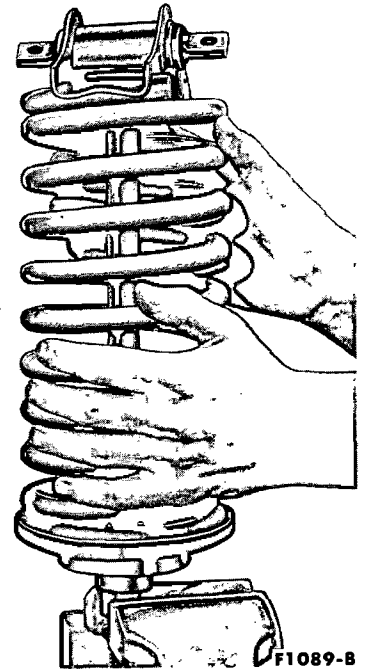

**FIG. 6—Spring Replacement**

2. Install the adjusting shims on both bolts between the inner shaft and the underbody. **Install the same shim thicknesses that were removed from both bolts during disassembly.** Torque the nuts to specification.

3. Position the upper ball joint stud in the top of the wheel spindle, and install the stud nut. Torque the nut to specification, and continue to tighten it until the cotter pin hole and slots line up. Install a new cotter pin.

4. Lubricate the upper ball joint.

5. Position the support between the upper arm and frame and install the coil spring. Follow steps 4 through 9 under "Installation" in the foregoing procedure.

6. **Check and, if necessary, adjust caster, camber, and toe-in.**

#### LOWER ARM REPLACEMENT

##### Removal

1. Position the tool shown in Fig. 3 under the upper arm for support.

2. Raise the car, position safety stands, and remove the wheel and tire.

3. Remove the stabilizer bar and link retaining nut, disconnect the bar from the link, and remove the link bolt.

4. Remove the strut to lower arm retaining nuts and bolts, and remove

100% SATISFACTION GUARANTEED

**BUY IT NOW!**

Click Here To Order

PayPal, American Express, Discover, MasterCard, VISA

the steering arm stop.

5. Remove the cotter pin from the nut on the lower ball joint stud, and loosen the nut one or two turns. **Do not remove the nut from the stud at this time.**

6. Straighten the cotter pin on the upper ball joint stud nut. Position ball joint remover tool between the upper and lower ball joint studs in the reverse position from that shown in Fig. 4. **The tool should seat firmly against the ends of both studs and not against the stud nuts.**

7. Turn the tool with a wrench until the tool places the studs under tension, and tap the spindle near the lower stud with a hammer to loosen the stud in the spindle. **Do not loosen the stud in the spindle with tool pressure only.** If both arms are being removed, loosen the upper stud in the same manner as the lower stud.

8. Remove the nut from the lower ball joint stud, and lower the arm.

9. Remove the lower arm to underbody pivot bolt, nut and washer. Remove the lower arm.

#### Installation

1. Position the lower arm to the underbody and install the pivot bolt, washer, and nut. Torque to specification.

2. Install the stabilizer link bolt, washers, bushings and spacer. Connect the stabilizer bar to the link. Install the retaining nut and torque to specification (Fig. 1).

3. Using a floor jack, raise the lower suspension arm, and guide the lower ball joint stud into the spindle. Install the stud nut and torque to specification.

4. Position the strut and steering arm stop to the lower control arm. The stop goes between the arm and strut. Install the retaining bolts and nuts and torque to specification.

5. The distance from the back face of the strut rear insulator washer to the center of the strut-to-lower arm front retaining bolt should be  $16\frac{1}{16}$  inches (Fig. 1). Check and, if necessary, correct by turning the strut adjusting nuts.

6. Install the lower ball joint re-

move the safety stands, and lower the car. Remove the tool supporting the upper arm.

9. Check and, if necessary, adjust caster, camber, and toe-in.

### FRONT WHEEL SPINDLE REPLACEMENT

#### Removal

1. Position a support between the upper arm and frame as shown in Fig. 3, then raise the car and position safety stands.

2. Remove the hub cap or wheel cover, and back off the brake shoe adjusting screw.

3. Remove the grease cap from the hub, then remove the adjusting nut, washer, and outer bearing cone and roller assembly.

4. Pull the wheel, hub, and drum assembly off the wheel spindle.

5. Remove the brake carrier plate from the spindle. Support the plate to prevent damage to the brake hose.

6. Disconnect the spindle connecting rod end from the spindle arm using Tool OTC-462.

7. Remove the cotter pins from both ball joint stud nuts, and loosen the nuts one or two turns. **Do not remove the nuts from the studs at this time.**

8. Position the ball joint remover tool between the upper and lower ball joint studs (Fig. 4). **The tool should seat firmly against the ends of both studs and not against the stud nuts.**

9. Turn the tool with a wrench until the tool places the studs under tension, and, with a hammer, tap the spindle near the studs to loosen them in the spindle. **Do not loosen the studs in the spindle with tool pressure alone.**

10. Remove the stud nuts and the spindle from both studs, using a floor jack under the lower suspension arm.

#### Installation

1. Position the spindle on the lower ball joint stud and install the stud nut.

2. Using a floor jack raise the lower suspension arm, and guide the upper ball joint stud into the spindle. Install the stud nut.

3. Torque the upper stud nut then the lower stud nut to specification. Continue to tighten both nuts until the cotter pin holes and slots line up. Install new cotter pins.

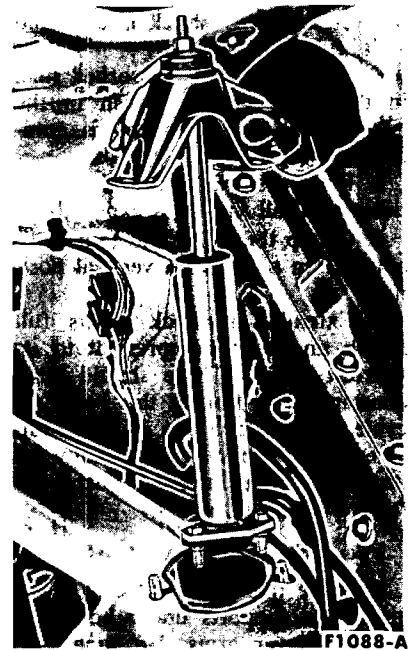

FIG. 7—Removing Front Shock Absorbers

4. Connect the spindle connecting rod end to the spindle arm.

5. Install the brake carrier plate on the spindle, and torque the bolts to specification.

6. Install the wheel and drum, adjust the wheel bearing (Part 3-5) and adjust the brakes (Group 2).

7. Remove the safety stands, and lower the car.

8. Remove the support from between the upper arm and frame.

9. Check and, if necessary adjust caster, camber, and toe-in.

### SHOCK ABSORBERS

Passenger cars and station wagons are equipped with hydraulic shock absorbers of the direct-acting type and are nonadjustable and nonrefillable, and cannot be repaired.

Before replacing a shock absorber, check the action of the shock absorbers by grasping the bumper and jouncing the car up and down. If the shock absorbers are in good condition the car will immediately settle to a normal position after the bumper is released.

#### Testing

To check a shock absorber removed from a car proceed as follows:

1. Hold the shock absorber in the vertical position with the piston

(lower end) up, and pull out the piston rod until the shock is extended to its full length.

2. With the shock absorber held in the same position, push in the piston rod until the shock is compressed to its shortest length.

3. Repeat steps 1 and 2 several times until all the air is expelled.

4. Clamp the lower end (small diameter) in a vise in a vertical position.

5. Extend the shock to its full length and then compress it to its shortest length. There should be a constant drag during the complete cycle. Any sudden loss of drag indicates air in the system or faulty internal valve operation. Replace defective shock absorbers.

#### Front Shock Absorber Removal

1. Raise the front end of the car and place supports under both suspension lower arms. **Be sure that the lower end of the shock absorber remains accessible for servicing.**

2. Disconnect the shock absorber lower retaining nuts from the spring lower seat.

3. Remove the shock absorber upper mounting bracket retaining nuts. Lift the bracket and shock absorber from the car (Fig. 7).

4. Remove the shock absorber from the mounting bracket.

5. Remove the bushing and washers from the shock absorber stud.

#### Front Shock Absorber Installation

1. Assemble the bushings to the shock absorber lower attaching studs.

2. Install the washer and upper bushing to the shock absorber. Install the upper mounting bracket, bushing, washer and retaining nut to the shock absorber.

3. Extend the shock absorber and install to the spring lower seat. Install the lower bushings, washers, and torque the nuts to specification.

4. Install the upper mounting bracket to the body. Torque the retaining nuts to specification.

5. Torque the shock absorber to mounting bracket nut to specification.

each link. Disconnect both stabilizer retaining brackets, and remove the stabilizer.

#### Installation

1. Coat the necessary parts of the stabilizer with RUGLYDE or a comparable lubricant, and slide new insulators onto the stabilizer.

2. Connect the stabilizer retaining brackets, and connect the stabilizer to both links. Torque the bracket retaining screws and the link bolt nut to specification.

3. Remove the supports and lower the car.

#### LOWER ARM STRUT AND/OR BUSHING REPLACEMENT

##### Removal

1. Position the tool shown in Fig. 3 under the upper arm for support.

2. Raise the car, position safety stands, and remove the wheel and tire.

3. Remove the strut-to-bracket forward retaining nut, washer and insulator bushing.

4. Remove the two strut-to-lower arm retaining nuts and bolts, remove the steering arm stop, then lift the strut with rear insulator bushing, washer from the car (Fig. 1).

##### Installation

1. Install the rear nut, washer, and insulator bushing to the strut.

2. Position the strut into the mounting bracket and to the lower suspension arm. Position the steering arm stop between the strut and the arm, install the strut-to-arm retaining bolts and nuts, and torque to specification.

3. Install the outer insulator bushing, washer, and nut to the forward end of the strut, and torque the strut rod nuts to specification.

4. Install the wheel and tire, remove the safety stands and lower the car. Remove the tool supporting the upper arm.

#### REAR SUSPENSION

##### REAR SPRING REPLACEMENT

##### Removal

1. Raise the car on a hoist and place supports beneath the underbody and under the axle.

2. Disconnect the lower end of the shock absorber from the spring clip plate, and push the shock out of the way.

3. Remove the spring clip plate

nuts from the U-bolts, then remove the plate (Fig. 11).

4. Remove the two retaining nuts, the rear shackle bar, and the two shackle inner bushings.

5. Remove the rear shackle assembly and the two outer bushings.

6. Remove the front hanger bolt, washer, and inner rubber bushing from the eye at the forward end of the spring, then lift out the spring assembly. Remove the outer bushing from the eye of spring.

#### Installation

1. Install the outer bushing in the eye at the forward end of the spring. **The forward end is the shorter end of the spring between the center tie bolt and the spring eye.** Install the two outer bushings in the rear shackle assembly.

2. Position the spring under the rear axle and insert the shackle assembly into the rear hanger bracket and the rear eye of the spring.

3. Install the shackle inner bushings, the shackle plate, and the locknuts. Tighten the locknuts finger tight.

4. Position the spring forward eye to the front hanger, and insert the front hanger stud through the eye and hanger. Tighten the stud finger tight.

5. Torque the rear shackle locknuts to specification.

6. Lower the rear axle until it rests on the spring. Position the spring clip

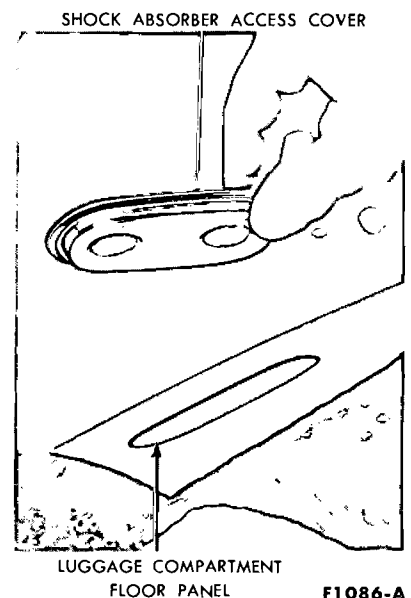

FIG. 8—Rear Shock Absorber Access Cover

**100% SATISFACTION GUARANTEED**

**STABILIZER REPLACEMENT**

**BUY IT NOW!**

**Click Here To Order**

Disconnect the stabilizer from

PayPal American Express Discover Novus MasterCard VISA

plate on the clips (U-bolts). Install the U-bolt nuts and torque to specification.

7. Connect the lower end of the shock absorber to the spring clip plate.

8. Place safety stands under the rear axle, lower the car until the spring is in the approximate curb load position, and then torque the front hanger stud locknut to specification.

9. Remove the safety stands and lower the car.

**REAR SHOCK ABSORBER REMOVAL**

1. Disconnect the shock absorber from the spring clip plate (Fig. 10).

2. On the passenger car, remove the shock absorber access cover from the luggage compartment (Fig. 8).

On the Ranchero, remove the retaining screws, and lift the forward half of the floor panel from the body; then remove the access cover from the opening in the floor pan over the shock absorber.

On station wagons, remove the access cover from the opening in the seat riser over the shock absorber.

3. Remove the shock absorber upper retaining nut.

4. Compress the shock absorber and remove it from the car. Remove the bushings and washers from the shock absorber studs.

**REAR SHOCK ABSORBER INSTALLATION**

1. Place the bushings and washers

on the shock absorber studs.

2. Connect the upper stud to the bracket, and install the bushing, washer, and nut on the stud. Torque the nut to specification, and install the cover (on a station wagon or car).

On the Ranchero, after installing the access cover in the floor pan, install the forward half of the floor panel.

3. Connect the lower stud to the spring clip plate, and install the bushing, washer, and nut on the stud. **Be sure the spring clip plate is free of burrs.** Tighten the nut to specification.

**REAR SUSPENSION ALIGNMENT CHECK**

Suspected misalignment or "dog tracking of front and rear wheel treads should be checked. Drive the car straight ahead on a section of pavement, part of which is wet, and stop about ten feet beyond the wet area. If alignment is correct, the rear tire imprints will appear an equal distance slightly outside the front tire tracks (Fig. 9). It is permissible to have a variation of 3/4 inch width in the tire imprints.

**TIE BOLT OFF-CENTER**

Misalignment may result from a rear spring tie bolt head which is not centered in the locating hole of the spring mounting pad on the axle housing (Fig. 10). To determine whether or not this bolt is off-center, measure the distance A (Fig. 11).

Dimension A should be the same,

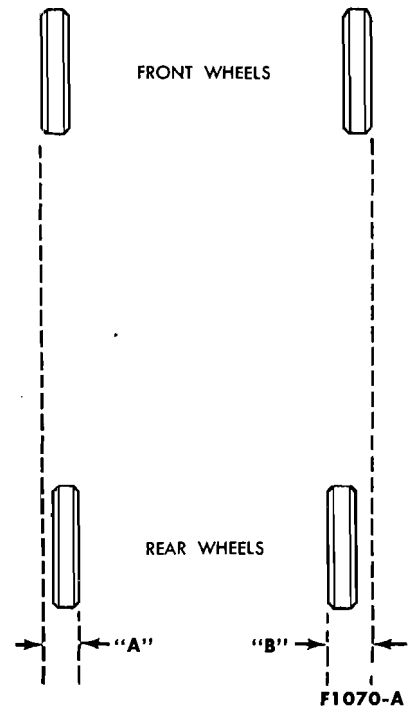
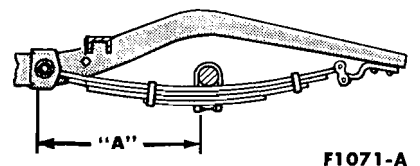

**FIG. 9—Suspension Alignment Check**

within 1/8 inch, on both sides of the car.

To center the tie bolt in the axle pad seat or lower spring clip plate take the following steps:

1. Loosen the four spring clip nuts.
2. With a jack, push or pull the housing into position.
3. While there is jack pressure, move the spring clip into line with the new position of the housing.
4. Torque the spring clip nuts to specifications.
5. Recheck the distance between front and rear tire imprints, and adjust further if necessary.



**FIG. 11—Rear Spring Hanger Alignment Check**

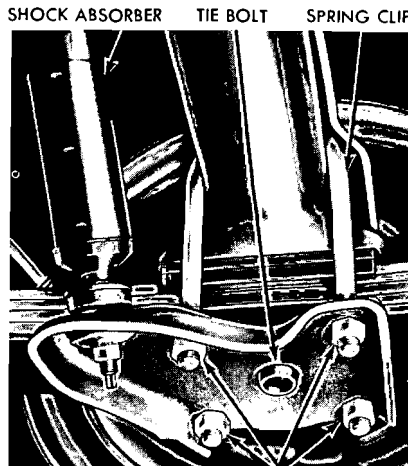
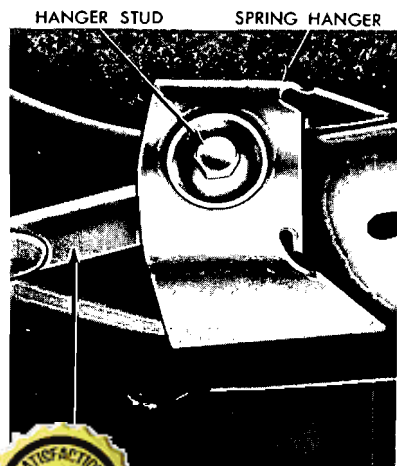

SPRING CLIP NUTS F1133-A

Typical

**100% SATISFACTION GUARANTEED**

**BUY IT NOW!**

**Click Here To Order**

PayPal American Express Discover/Novus MasterCard VISA

# PART 3-3 MANUAL STEERING

Section	Page	Section	Page
1 Description .....	3-14	4 Major Repair Operations .....	3-17
2 In-Car Adjustments and Repairs .....	3-14	5 Steering Linkage Repair .....	3-18
3 Removal and Installation .....	3-16		

## 1 DESCRIPTION

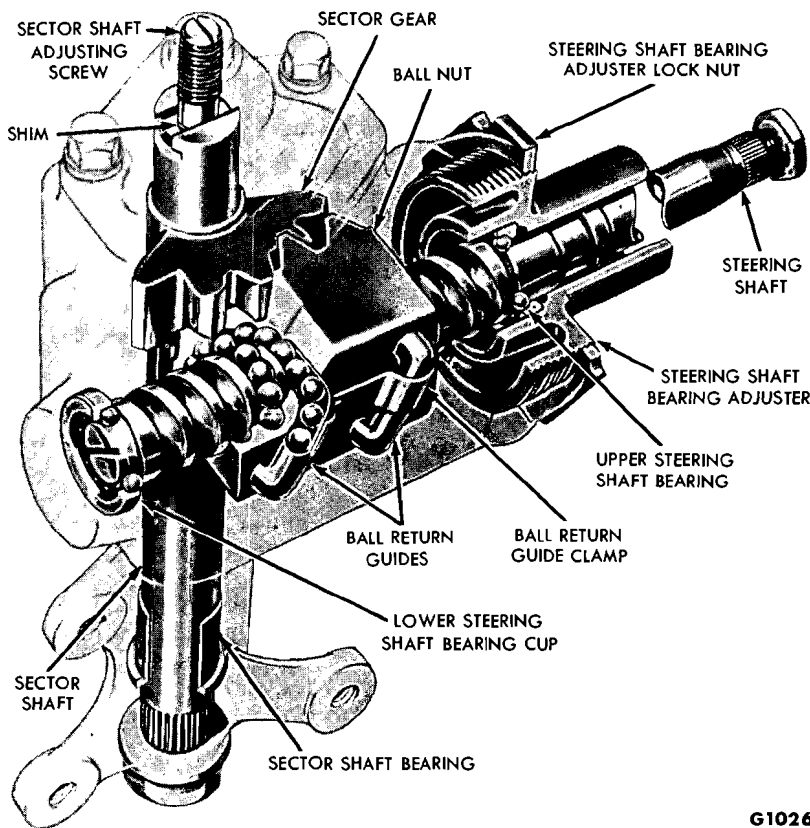
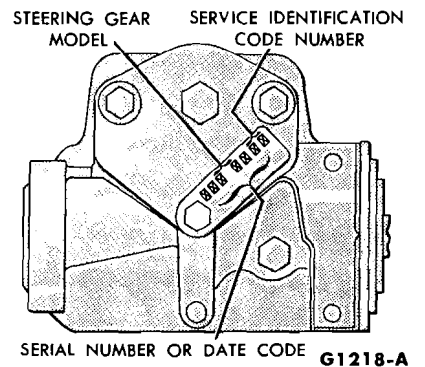

**FIG. 1—Recirculating Ball Type Steering Gear**

The steering gear (Fig. 1) is of the worm and recirculating ball type. The sector shaft rotates in needle bearings that are pressed into the gear housing.

The worm bearing preload is controlled by the large bearing adjuster which is threaded into the housing. The sector shaft mesh load is controlled by an adjusting screw located in the housing cover.

A steering gear identification tag is provided under one of the cover attaching bolts (Fig. 2).



**FIG. 2—Steering Gear Identification Tag**

## 2 IN-CAR ADJUSTMENTS AND REPAIRS

### STEERING WORM AND SECTOR GEAR ADJUSTMENTS

the ball nut assembly and the sec-

ments within the recirculating ball-type steering gear, and these should be made in the following order to avoid damage or gear failure.

1. Disconnect the Pitman arm from the sector shaft.
2. Remove the steering wheel, spring and the centering cone from the shaft and note the relation of the shaft to the bearing.

3. If the shaft is not centered, attach a spring scale to it.

4. Center the shaft by pulling on the scale and note the reading.

5. If more than 20 lbs. pull is required to center the shaft, the steering column should be aligned as detailed in steering gear installation, before adjusting the preload and mesh load.

**100% SATISFACTION GUARANTEED**

**BUY IT NOW!**

**Click Here To Order**

PayPal, American Express, Discover, MasterCard, VISA

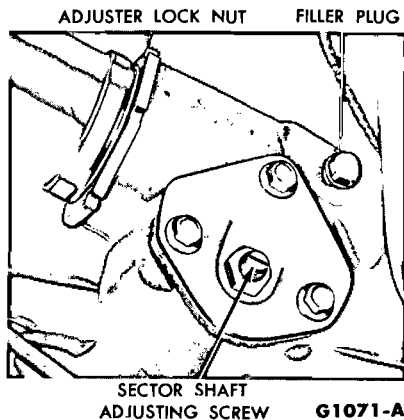

**FIG. 3—Steering Gear Adjustments**

6. Loosen the nut which locks the sector adjusting screw (Fig. 3), and turn the adjusting screw counter-clockwise.

7. Measure the worm bearing preload by attaching an inch-pound torque wrench to the steering wheel nut (Fig. 4). With the steering wheel off center, read the pull required to rotate the input shaft approximately  $1\frac{1}{2}$  turns either side of center. If the torque or preload is not within specification (Part 3-6), adjust as explained in the next step.

8. Loosen the steering shaft bearing adjuster lock nut, and tighten or back off the bearing adjuster (Fig. 3) to bring the preload within the specified limits.

9. Tighten the steering shaft bearing adjuster lock nut, and recheck the preload.

10. Turn the steering wheel slowly to either stop. Turn gently against the stop to avoid possible damage to the ball return guides. Then rotate the wheel  $2\frac{1}{4}$  turns to center the ball nut.

11. Turn the sector adjusting screw clockwise until the specified pull (Part 3-6) is necessary to rotate the worm past its center high spot (Fig. 4). No perceptible backlash is permissible at  $30^\circ$  on either side of center.

12. While holding the sector adjusting screw, tighten the locknut to specification and recheck the backlash adjustment.

13. Connect the Pitman arm to the sector shaft.

### STEERING WHEEL SPOKE POSITION ADJUSTMENT

When the steering gear is on the high point, the front wheels should be in the straight-ahead position and the steering wheel spokes should be in their normal position with the Pitman arm pointing directly forward. If the spokes are not in their normal position, they can be adjusted without disturbing the toe-in adjustment (Part 3-1).

### STEERING WHEEL REPLACEMENT

1. Remove the horn ring (or button) assembly and related parts.

2. Remove the steering wheel attaching nut and remove the steering wheel from the shaft, using the tool shown in (Fig. 5).

3. With the front wheels straight forward, position the steering wheel on the steering shaft with the spokes properly centered and the splines on both parts properly aligned.

4. Install the steering wheel nut on the shaft. Torque the nut to specification, and stake it in place.

5. Install the horn ring (or button) assembly and the related parts.

### STEERING COLUMN SHIFT TUBE REPLACEMENT

#### REMOVAL

1. Remove the steering wheel, spring and centering sleeve.

2. Remove the turn indicator lever. Place the gear shift selector lever in the neutral position and remove the lever.

3. Loosen the flange retaining nuts until pressure on the nuts (toward the column center) will disengage the bolt heads. Lift the flange from the column and drape the flange and the signal wires over the top of the column.

4. Remove the gear shift lever socket from the steering column.

5. Remove the shift tube.

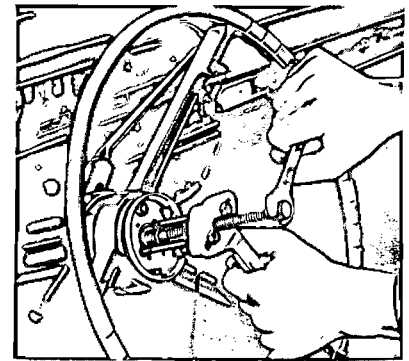

**FIG. 5—Removing Steering Wheel—Typical**

### INSTALLATION

1. After applying Lubriplate to the lower area of the shift tube, position the shift tube in the steering column tube. The shift tube is seated when spring pressure can be felt.

2. Install the gear shift lever socket, being careful not to damage the wiring insulation as the socket is positioned.

3. Install the flange and tighten the retaining nuts.

4. Install the turn signal lever and the selector lever.

5. Install the centering sleeve, spring and steering wheel.

### STEERING COLUMN UPPER BEARING REPLACEMENT

1. Disconnect the horn wire and the turn indicator wires at the connectors. Remove the horn ring (or button) and the spring.

2. Remove the steering wheel attaching nut. Remove the steering wheel (Fig. 5) with a puller. Lift the spring and the centering sleeve from the shaft.

3. Remove the turn indicator lever. Remove the upper bearing retainer screws and move the turn signal switch to one side.

4. Remove the steering column upper bearing from the flange.

5. After applying Lubriplate, install the new upper bearing.

6. Position the upper bearing retainer and the signal switch and install the three retainer screws.

7. Install the turn indicator lever and position the centering sleeve and the spring. After applying Lubriplate to the horn switch brush plate, install the steering wheel.

8. Connect the turn indicator and horn wires and test their operation.

TORQUE WRENCH  
(In.-Lb.)

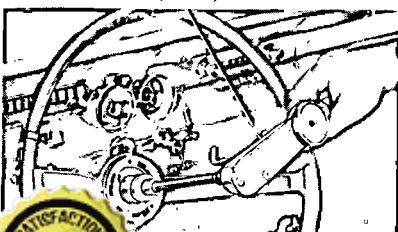

**100% SATISFACTION GUARANTEED**

**BUY IT NOW!**

**Click Here To Order**

PayPal American Express Discover.com/US MasterCard VISA

### ③ REMOVAL AND INSTALLATION

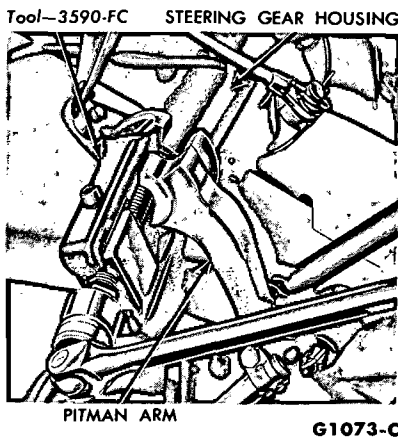

**FIG. 6—Removing Pitman Arm**

#### STEERING GEAR REMOVAL AND INSTALLATION

##### REMOVAL

1. Raise the front of the car onto safety stands. Remove the Pitman arm from the sector shaft (Fig. 6).
2. Remove the steering gear attaching bolts and disconnect the transmission shift rod(s) at the gear shift lever(s).
3. Pull the rubber seal up on the steering column, fold the floor mat aside, and move the dash panel insulation out of the way.
4. Remove the retaining screws from the steering column weather seal on the dash panel. Remove the steering column cover plates and gasket.
5. Disconnect the horn and turn indicator wires under the instrument panel. Also on a car with an automatic transmission, disconnect the neutral switch wires.
6. Remove the horn ring (or button). Remove the steering wheel retaining nut and the steering wheel (Fig. 5).
7. Remove the upper bearing centering sleeve and spring.
8. Remove the steering column clamp to instrument panel bolts and remove the clamp (upper and lower halves) and the insulator.
9. Slide the steering column tube assembly from the steering gear shaft, and move the shift lever(s) up through

careful not to soil or tear the front seat fabric.

- b. On a car equipped with an 8-cylinder engine, disconnect the wires from the spark plugs on the left side of the engine and place them to one side.
11. Remove the master cylinder attaching bolts and remove the lower brake line to dash panel attaching clip. Move the master cylinder upward toward the cross-brace taking care not to kink the brake tubes.
  12. Remove the No. 7 cylinder rear exhaust upper manifold attaching bolt.
  13. Lift the steering gear and shaft assembly from the engine compartment by raising the gear up and forward past the engine and spring taking care not to soil or tear the front seat fabric.

##### INSTALLATION

1. Install the steering gear.
    - a. On a car equipped with a 6-cylinder engine, guide the shaft through the dash panel being careful not to soil or tear the front seat fabric. Install but, do not tighten the steering gear attaching bolts.
    - b. On a car equipped with an 8-cylinder engine, guide the shaft through the dash panel being careful not to soil or tear the front seat fabric. Install, but do not tighten the steering gear attaching bolts.
- Position the master cylinder and install and torque the bolts to specification. Position the brake tube lower and install the attaching clip.
- Connect the left bank of spark plug wires. Install the manifold attaching bolt that was previously removed.
2. Slide the steering column tube assembly over the steering shaft, guiding the shifting arms through the rubber seal at the dash panel.
  3. Position the steering column assembly and retaining clamp and insulator, and loosely install the attaching bolts and nuts.

4. Tighten the steering gear to side rail mounting bolts and column to instrument panel retaining bracket.

5. After tightening the steering gear to side rail mounting bolts and column to instrument panel retaining bracket, check the steering shaft

to column upper bearing clearance. If the shaft does not touch the bearing, no further re-adjustment is required. If the shaft is touching the column upper bearing, it will be necessary to check the pull required to center the shaft in the column, using a fish scale. Where pull exceeds 20 lbs. at either plane to center the shaft in the column, the following correction must be made:

Vertical movement of the steering shaft can be accomplished by loosening the steering gear mounting bolts and pivoting the gear up and down.

Horizontal movement of the steering shaft can be accomplished by loosening the steering column to instrument panel retaining bracket and moving the column to the left or right.

Should additional horizontal movement be required to align the steering shaft, it will be necessary to insert shim(s) of proper thickness between the steering gear assembly and the vehicle side rail. Front end alignment shims can be used for this purpose. After the steering shaft is centered, torque all bolts to specification.

6. Position the upper bearing centering sleeve and spring. After applying Lubriplate to the upper surface of the steering shaft upper bearing and the horn switch brush plate, position the steering wheel. Install and stake the retaining nut. Install the turn indicator lever.

7. Install the horn ring (or button) and spring, and steering wheel to the center point.

8. Position the sector shaft arm, and torque the attaching nut to specification.

9. Lower the car from the safety stands. Connect the horn, turn indicator wires, and (on a car with an automatic transmission) the neutral switch wires.

10. Connect the transmission shift rod(s). Position the steering column cover plates and gasket on the dash panel and install the retaining screws.

11. Position the dash panel insulation just above the steering column. Position the floor mat and push the rubber seal down to the floor mat.

12. If necessary, correct adjustment of the shift lever(s) and the neutral switch.

**100% SATISFACTION GUARANTEED**

**BUY IT NOW!**

**Click Here To Order**

PayPal American Express Cards DISCOVER NOVUS MasterCard VISA

## 4 MAJOR REPAIR OPERATIONS

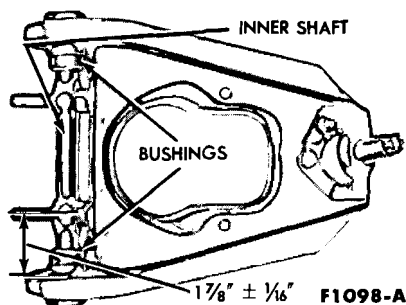

**FIG. 7—Installing Inner Arm and Bushing**

### UPPER ARM OVERHAUL—ARM REMOVED

#### BUSHING AND INNER SHAFT REPLACEMENT

Always replace both upper arm bushings if either bushing is worn or damaged. Install only new bushings when replacing the inner shaft.

1. Unscrew the bushings from the inner shaft and suspension arm, then remove the shaft from the arm.

2. Position the shaft in the arm. Lubriplate and install the new bushings on the shaft and the arm. Turn the bushings so that the shaft is exactly centered in the arm. The shaft will be properly centered when located at the dimension shown in Fig. 7. Position the bushings carefully to avoid damaging the O-rings inside the bushings.

3. Torque the bushings to specification.

### UPPER BALL JOINT REPLACEMENT

The upper ball joints can be replaced with the upper arm in the car. If replacement is required refer to Section 3 "In-Car Adjustment and Repairs".



### STEERING GEAR

#### DISASSEMBLY

1. Rotate the steering shaft approximately  $2\frac{1}{4}$  turns from either stop.

2. After removing the sector adjusting screw locknut and the housing cover bolts, remove the sector shaft with the cover. Remove the cover from the shaft by turning the screw clockwise. **Keep the shim with the screw.**

3. Loosen the worm bearing adjuster nut, and remove the adjuster assembly and the steering shaft upper bearing and cup.

4. Carefully pull the steering shaft and ball nut from the housing. To avoid possible damage to the ball return guides, keep the ball nut from running down to either end of the worm.

Disassemble the ball nut only if there is indication of binding or tightness.

5. Remove the lower bearing and cup from the housing. It may be necessary to tap the housing on a block of wood (Fig. 8) to loosen it from the housing.

6. Remove the ball return guide clamp and the ball return guides from the ball nut. **Keep the ball nut clampside up until ready to remove the balls.**

7. Turn the ball nut over, and rotate the worm shaft from side to side until all 62 balls have dropped out of the nut into a clean pan. With the balls removed, the ball nut will slide off the worm.

Press both sector shaft bearings out of the housing (Fig. 9). Remove the seal and the bearings only if there is an indication of wear or damage, or bearing mislocation. Do not install a new bearing in a housing in which the bearing has turned or found to be mislocated. A new housing must be used.

### STEERING GEAR

#### ASSEMBLY

1. If the sector shaft bearings have been removed, press new bearings into the housing (Fig. 10).

2. Position a bearing cup in the adjuster.

3. If the sector shaft oil seal has been removed, install a new oil seal.

4. Swab the inside diameter of the ball nut and the outside diameter of the worm with gear lubricant ESW-

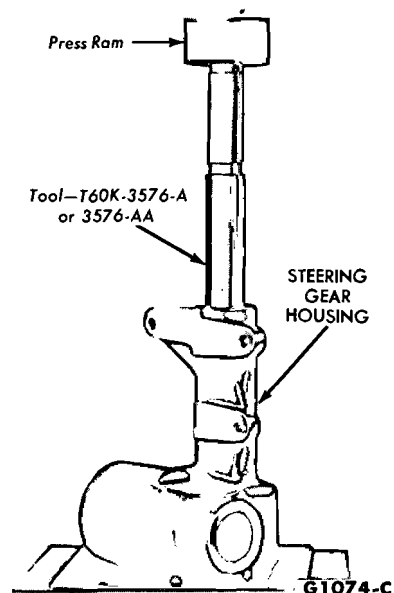

**FIG. 9—Removing Sector Shaft Bearing**

M-1687-A prior to assembly. Lay the steering shaft on a bench as shown in Fig. 11. After positioning the shaft, turn the ball nut to place the guide holes in the up position. Align the grooves in the worm and in the ball nut by sighting through the ball guide holes.

5. Count 31 balls, and drop as many of them as possible into one of the guide holes, slowly turning the worm away from the holes, until that circuit is full or until rotation is

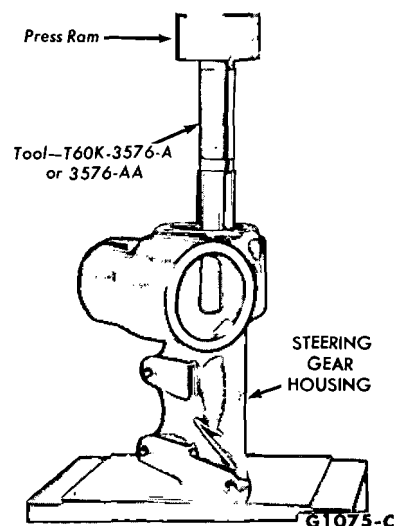

**FIG. 10—Installing Sector Shaft Bearing**

**100% SATISFACTION GUARANTEED**

**BUY IT NOW!**

**Click Here To Order**

PayPal | American Express | Discover | MasterCard | VISA

stopped by the end of the worm. If the balls are stopped by the end of the worm, hold in those already positioned, and turn the worm in the opposite direction. The filling of the circuit can then be continued until most of the balls are in place.

6. Lay one half of the ball return guide on the bench, and place the remainder of the 31 balls in it. Position the second half of the guide and, holding the two halves together, plug each open end with gear lubricant so the balls will stay in the guide when it is installed.

7. Push the guide into the guide holes of the ball nut, tapping lightly with the wooden handle of a screw driver if necessary.

8. Assemble the second ball return circuit in the same way as the first.

9. Install the ball return guide clamp and screws. Check the ball nut to see that it rotates freely. Torque the screw to specification.

10. Coat the threads of the steering shaft bearing adjuster, the housing cover bolts, and the sector adjusting screw with a suitable oil-resistant sealing compound. **Do not apply sealer to female threads, and especially avoid getting any sealer on the steering shaft bearings.**

11. Coat the worm bearings, sector shaft bearing and gear teeth with

gear lubricant ESW-M1687-A.

12. Clamp the housing in a vise, with the sector shaft axis horizontal, and position the steering shaft lower bearing cup and the bearing in place.

13. Position the steering shaft and ball nut assembly in the housing.

14. Position the steering shaft upper bearing on the top of the worm, and install the steering shaft bearing adjuster and cup. Install the lock nut with the flat side against the bearing adjuster and the letter "S" outward. Leave the nut loose.

15. After installing the steering wheel nut on the steering shaft, adjust the worm bearing preload, using an inch-pound torque wrench to check for specified preload.

16. Position the sector adjusting screw and the adjuster shim, and check the end clearance which should not exceed 0.002 inch between the screw head and the end of the sector shaft. If clearance is greater than 0.002 inch, replace the shim.

17. Thread the sector shaft adjusting screw into the housing cover.

18. Install a new gasket on the housing cover.

19. Rotate the steering shaft until the ball nut teeth are in position to mesh with the sector gear, tilting the housing so that the ball nut will tip

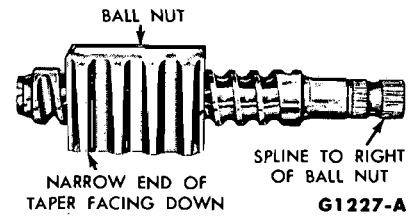

**FIG. 11—Positioning Ball Nut—Typical**

toward the housing cover opening.

20. Apply enough gear lubricant ESW-M1687-A to fill the pocket in the housing between the sector shaft bearings 30% full.

21. Push the housing cover with the sector shaft into place.

22. Turn the cover to one side and fill the housing with ½ lb. of gear lubricant ESW-M1687-A.

23. **Install but do not tighten the housing cover attaching bolts. Do not tighten the cover bolts until it is certain that there is some lash between the ball nut and the sector gear teeth.**

24. After loosely installing the sector shaft adjusting screw lock nut, adjust the sector shaft mesh to the specified mesh load, then tighten the adjusting screw lock nut. Remove the steering wheel nut.

## **B** STEERING LINKAGE REPAIR

The manual steering linkage (Fig. 12) consists of the Pitman arm, the steering arm-to-idler arm rod, the steering idler arm, and the spindle connecting rods (tie rods). **Do not attempt to straighten bent linkage; use new parts.**

### **SPINDLE CONNECTING ROD END REPLACEMENT**

The spindle connecting rod ends, which are threaded into the outer ends of the rod sleeves, have non-adjustable, spring-loaded ball studs. A rod end should be replaced when excessive looseness at the ball stud is noticed.

1. Remove the cotter pin and nut from the worn rod end ball stud (Fig. 12).

Disconnect the end from the

all rod end parts that were removed from the sleeve. **All new parts should be used when a spindle connecting rod end is replaced.**

4. Thread a new rod end into the sleeve, but do not tighten the sleeve clamp bolts at this time.

5. Install the seal on the rod end ball stud, insert the stud in the part from which the old one was removed, and install the stud nut. Torque the nut to specification and install the cotter pin.

6. Check and, if necessary, adjust toe-in (Part 3-1). **After toe-in is checked and adjusted, torque the old sleeve clamp bolts to specification. Add four pounds torque if new bolts are used.**

### **SPINDLE SLEEVE REPLACEMENT**

A spindle sleeve should be replaced if it becomes worn or damaged (Fig. 12). **Do not attempt to straighten the sleeve if threaded portion is damaged.**

1. Remove the spindle connecting rod ends as described in the previous sub-section.

2. Screw the spindle rod ends into the new sleeve the same number of turns as the ends that were removed. Do not tighten the clamp bolts at this time.

3. After installing the seal on the rod ends, position the sleeve assembly on the Pitman arm (or the idler arm) and the spindle arm. Install the attaching nut, torque it to specification, and install the cotter pin.

5. Check and, if necessary, adjust toe-in (Part 3-1). After toe-in is checked and adjusted, torque the sleeve clamp bolts to specification.

### **STEERING ARM-TO-IDLER ARM ROD REPLACEMENT**

The rod connecting the Pitman arm and the idler arm is non-adjustable and has non-adjustable ball studs on all 6-cylinder car steering linkage. On the 8-cylinder car linkage, the rod connecting the Pitman

**100% SATISFACTION GUARANTEED**

**BUY IT NOW!**

**Click Here To Order**

THE 100 END FROM THE SLEEVE

PayPal    American Express    Discover    MasterCard    VISA

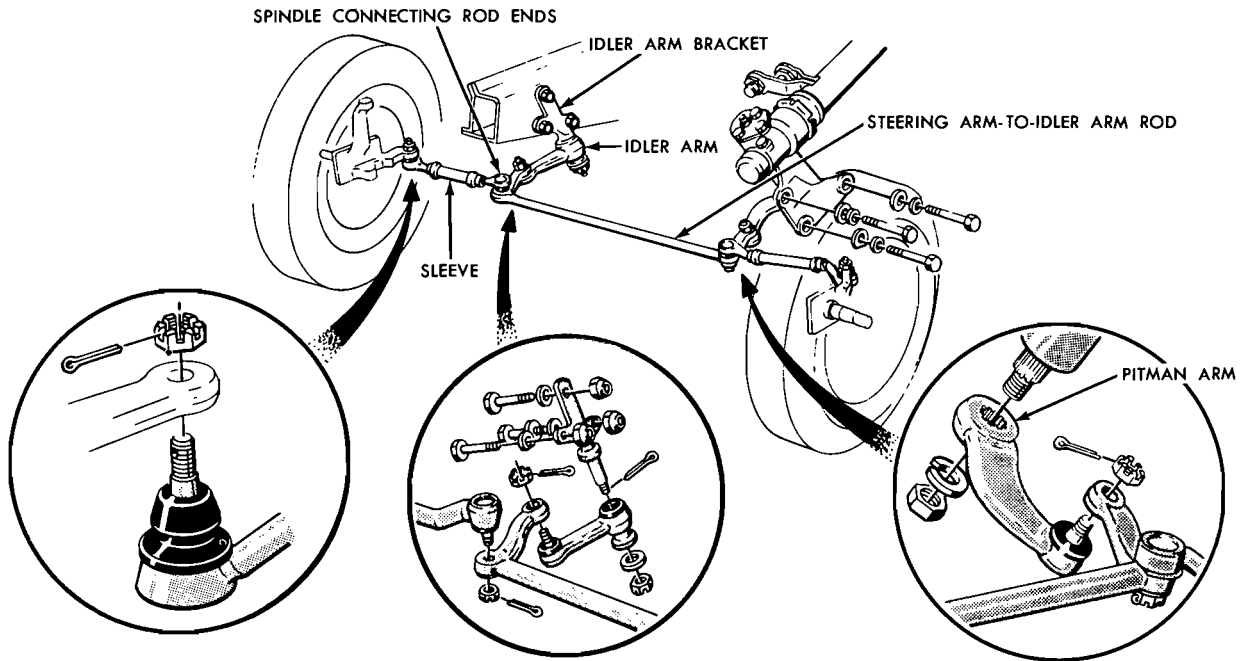

G1231-A

**FIG. 12—Typical Steering Linkage 8 Cylinder Shown**

arm and the idler arm is provided with tapered holes to accommodate the ball studs (Fig. 12). The rod should be replaced when damaged (all) or when worn at the ball studs (6 cylinder only).

1. Remove the cotter pins and nuts from the ball studs at the sector shaft arm and the idler arm, and remove the steering arm-to-idler arm rod (Fig. 13).

2. After installing new seals on the ball studs, position the new steering arm-to-idler arm rod on the idler arm and the steering arm.

3. Install the ball stud retaining nuts and torque to specification.

4. Install cotter pins, lubricate the power steering ball stud socket if necessary.

5. Check and, if necessary, ad-

just toe-in (Part 3-1).

**STEERING IDLER ARM BUSHING REPLACEMENT**

**6-CYLINDER CARS**

The idler arm used to service the Comet models includes the bushing, therefore it is only necessary to replace the complete arm when worn. Use the following procedure to replace the Falcon idler arm bushing:

To replace the bushing, use the tool shown in Fig. 14. After replacing the bushing and connecting the linkage, check and, if necessary, adjust the toe-in.

It will be necessary to replace the

idler arm if the bushing or ball joint is worn or damaged.

To replace the idler arm, remove the cotter pin and nut that secures the steering arm-to-idler arm rod. Disconnect the rod from the idler arm as shown in Fig. 13. Remove the cotter pin, nut and the washer that secures the idler arm to the idler arm bracket. Remove the idler arm from the bracket.

Position the new idler arm on the idler arm bracket and secure it with a washer and slotted nut. Secure the rod to the idler arm with a slotted nut. Torque the slotted nuts to specifications and install the cotter pins.

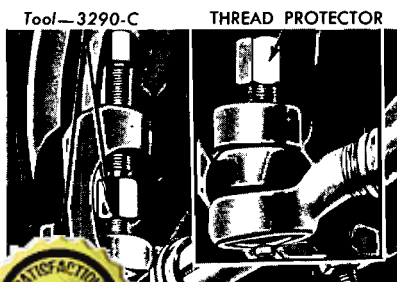

Tool—3290-C

THREAD PROTECTOR

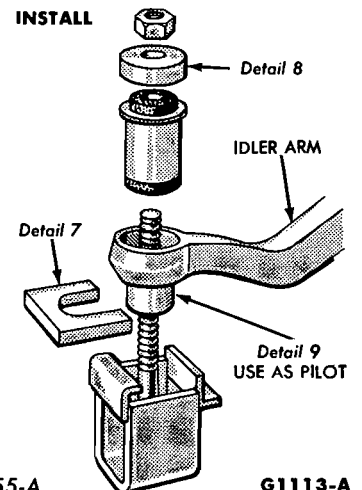
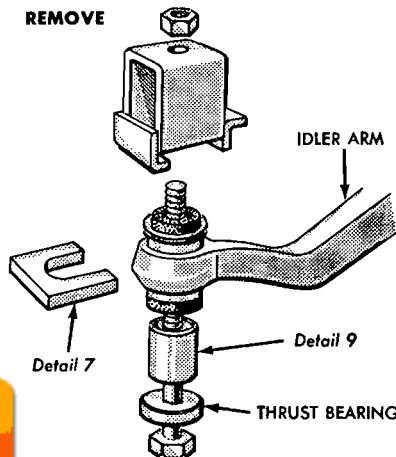

Tool—T61P-3355-A

G1113-A

**100% SATISFACTION GUARANTEED**

**BUY IT NOW!**

**Click Here To Order**

**FIG. 14—Replacing Idler Arm Bushing**

# PART 3-4 POWER STEERING

Section	Page	Section	Page
1 Description .....	3-20	3 Removal and Installation .....	3-22
2 In-Car Adjustments and Repairs .....	3-22	4 Major Repair Operations .....	3-23

## 1 DESCRIPTION

Master-Guide Power Steering (Fig. 1) is a hydraulically controlled linkage-type steering system which includes a fluid reservoir and pump, a control valve, a power cylinder, the connecting fluid lines, and the steering linkage. The roll-type hydraulic pump, belt-driven from the engine crankshaft, draws fluid from the reservoir and provides fluid pressure for the system. Within the pump itself is a pressure-relief valve which governs the pressures within the steering system according to the varying conditions of operation. After fluid has passed from the pump to the control valve and the power cylinder, it returns to the reservoir.

The control valve, operated by

steering wheel movement, directs the pressure developed by the pump. When the front wheels are in the straight-ahead position, the control valve spool is held in the center (neutral) position by its centering spring. Fluid then flows around the valve lands and returns to the reservoir (Fig. 2). Within the control valve body there is a reaction limiting valve which reduces parking effort.

When force of about 4 pounds is exerted for a left turn, the valve spool overcomes the pressure of the centering spring and moves toward the right end of the valve. As a result, pressure is exerted on the right side of the power cylinder piston,

and fluid in the left end of the cylinder returns to the reservoir (Fig. 2).

If the direction of the force on the steering wheel is reversed, the front wheels will return to the straight forward position. Or as force on the steering wheel falls below approximately 4 pounds the valve spool centering spring forces the spool back to the center position and there the pressure on both sides of the power cylinder piston is equal. With normal forward driving movement of the car and in the absence of operative pressure within the power cylinder, the front wheels will seek to return to the straight ahead position. This is a normal effect of the front wheel alignment.

For a right turn, the directional forces explained above are reversed (Fig. 2).

If, for any reason, the pump fails to deliver fluid pressure, the car may be steered without pump pressure. An engine idle speed control device (Fig. 3) eliminates the problem of the engine stalling when the driver parks the car. When the steering spindle arm stops are contacted, the output of the pump becomes maximum and the maximum pressure is directed to the control valve.

The maximum pressure causes the plunger of the control valve to move the bellcrank linkage; thus, the proper engine idle speed is maintained. Refer to the engine specification section of this manual for the proper engine idle speeds.

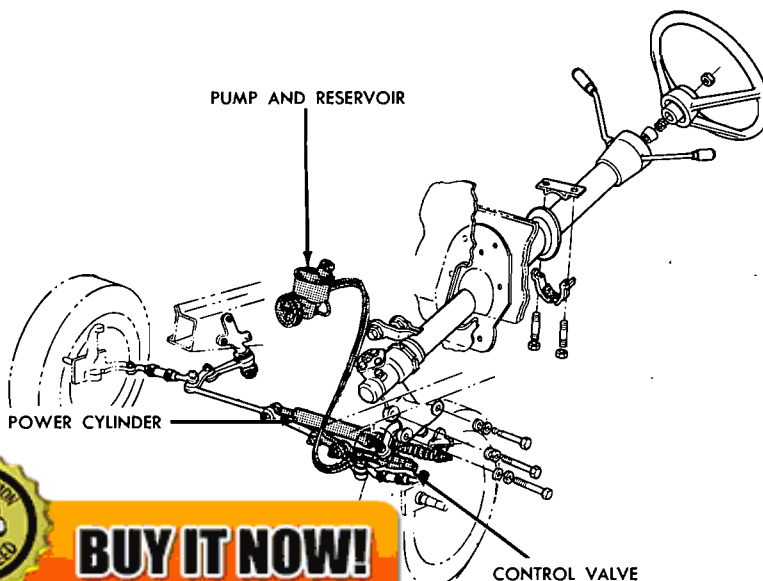

**100% SATISFACTION GUARANTEED**

**BUY IT NOW!**

**Click Here To Order**

POWER STEERING SYSTEM

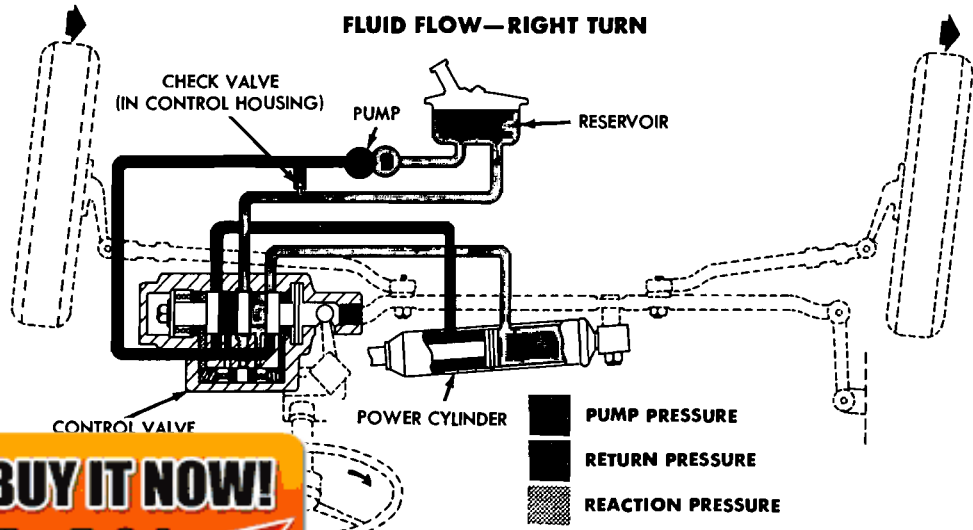
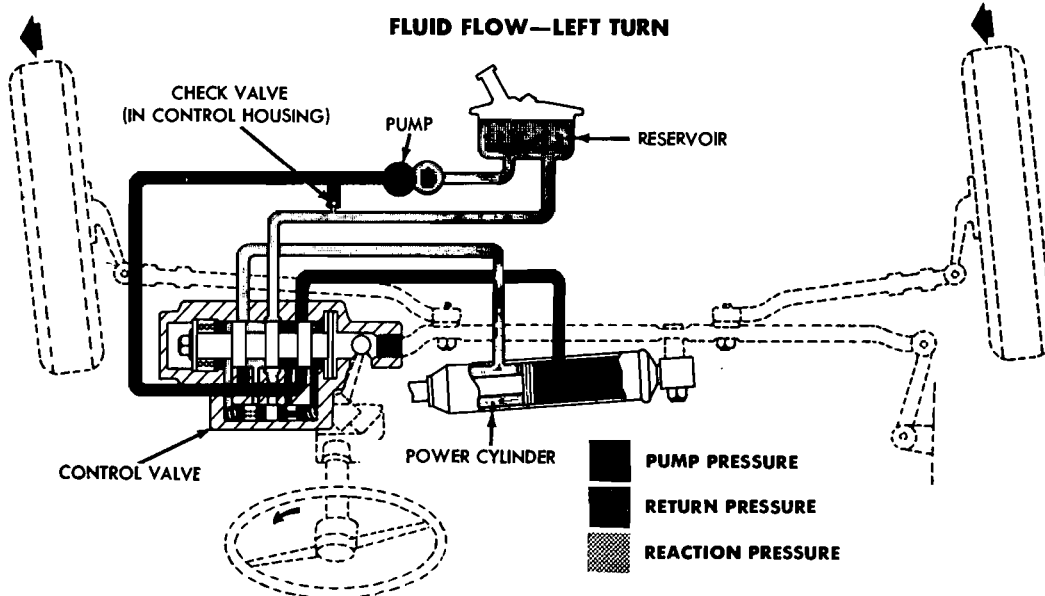
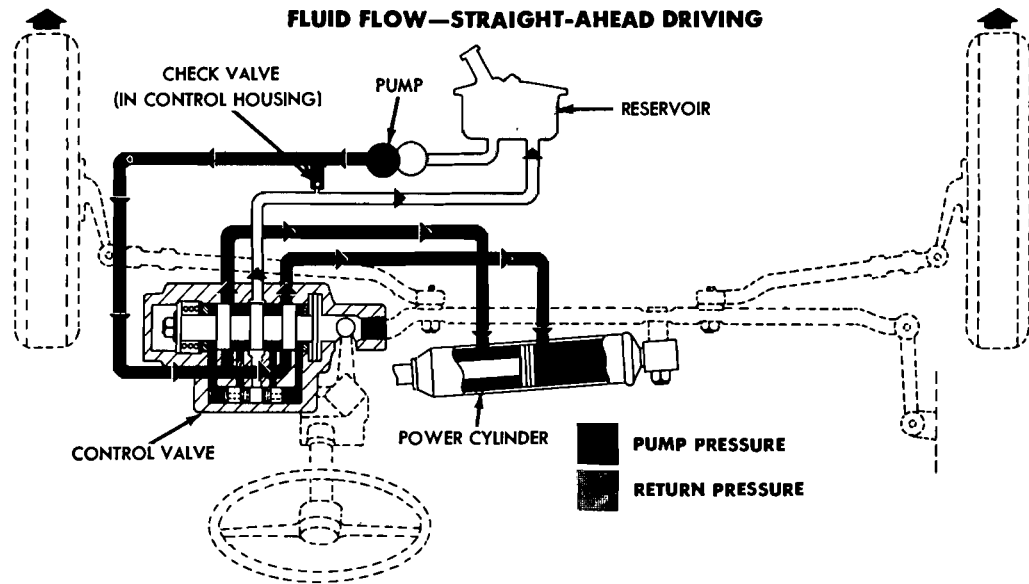

**100% SATISFACTION GUARANTEED**  
**BUY IT NOW!**  
[Click Here To Order](#)

## 2 IN-CAR ADJUSTMENTS AND REPAIRS

### PUMP BELT TENSION ADJUSTMENT

Pump drive belt tension cannot be checked accurately using the thumb pressure or belt deflection methods. Correct belt adjustment is assured only with the use of a belt tension gauge.

1. Check the belt tension with a gauge. With a new belt, or one that has been run for less than 15 minutes, the tension should be within 120-150 lbs. With a belt that has been run for more than 15 minutes, the

tension should be within 90-120 lbs.

2. To adjust the belt, loosen the pump pivot and adjusting bolts to allow movement of the bracket in its adjusting slot. Move the pump as required, and snugly tighten the bolts. **Do not move the pump by lifting or pulling on the reservoir.**

3. Recheck the belt tension. When the tension has been correctly adjusted, tighten the bolts to 22-28 ft-lbs torque.

### FILTER REPLACEMENT

1. Remove the cover from the

power steering pump or reservoir and remove the gasket. Clean the gasket surface.

2. Remove the fluid with a suction gun.

3. Lift the hold-down spring, washer, and the filter element from the reservoir.

4. Wipe the reservoir clean with a lint-free cloth.

5. Position a new filter unit on the seat (Fig. 4).

6. Cement (M2G14-A) a new cover gasket around the inside of the cover.

7. Position the retaining washer and the hold-down spring on the filter element.

8. Install the cover and gasket. On units equipped with remote mounted reservoir, turn the wing nut down until it is flush with the top of the stud.

9. Fill the reservoir and check for leaks.

10. Recheck the fluid level and replenish the fluid as required.

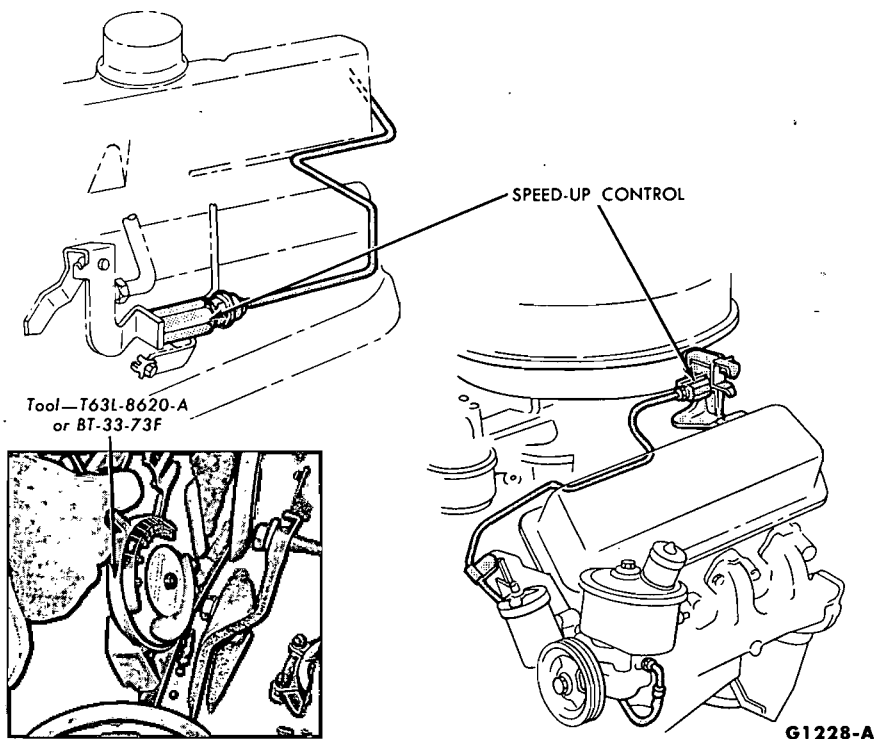

FIG. 3—Power Steering Idle Speed Control Valve

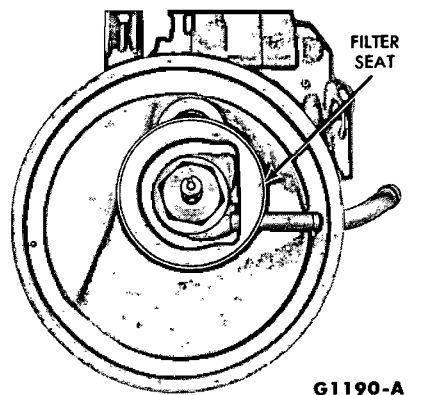

FIG. 4—Fluid Reservoir

## 3 REMOVAL AND INSTALLATION

### STEERING GEAR

Refer to Group 3-3, Section 3 for detailed instructions.

### POWER STEERING PUMP REMOVAL

Remove the fill cap from the reservoir and remove the fluid with

valve line from the pump.

5. Loosen the belt adjusting bolt and the pivot bolt. Remove the drive belt from the pump pulley.

6. Remove the power steering pump-to-bracket attaching bolts, then lift the pump from the engine.

### INSTALLATION

1. Secure the power steering pump to the bracket with the attaching bolts, but do not tighten the bolts at this time.

2. Position the drive belt on the

power steering pump pulley and on the crankshaft pulley.

3. With Tool T62L-8620-A installed on the pump drive belt, raise the pump to obtain the specified belt tension, then tighten the adjusting bolt.

4. Tighten all of the pump attaching bolts at this time.

5. Connect the oil pressure line and the idle speed-up line to the pump.

6. Connect the oil return line to the reservoir.

**100% SATISFACTION GUARANTEED**

**BUY IT NOW!**

**Click Here To Order**

DISCONNECT THE BLUE SPEED-UP

PayPal American Express Discover TRAVELERS MasterCard VISA

# This is only a **Demo** of the product! Only a few pages are included.

**Description:** The Ford Shop Manual is the original manual used by the Ford dealership mechanics at to guide them through repairs and maintenance. Each section provides information on the operation of major systems, diagnostics, troubleshooting, overhaul, as well as the removal and installation of major components. Written in an easy to understand format, this manual contains step-by-step instructions designed for the novice and the expert. In addition, this manual is filled with illustrations, photographs, and diagrams that help in the identification of parts and proper assembly.

Our manuals are fully approved and licensed by the Ford Motor Company

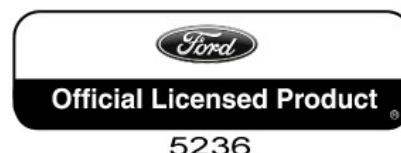

We are a licensed distributor of Adobe Reader



**Adobe Reader:** Unlike some CD-ROM versions on the market, this product is produced in Adobe Reader (pdf) format to retain the exact look and feel of the original manual. Simply scroll through the pages and sections like reading a normal printed manual. In addition, unlike a printed version, each page can be printed (or reprinted, if damaged in the garage), zoom in to over 1200% to see the exact details, and you can search for keywords.

## Product Features:

- ▶ Printable - Print only the pages you need (if a page is damaged in the shop, just print a new one!)
- ▶ Searchable - Search the entire manual in seconds.
- ▶ Zoom - Zoom in to over 1200% to see the exact details.
- ▶ Transportable - Use on any Windows computer. No additional software needed.
- ▶ Bookmarked - Manual is bookmarked to locate sections in seconds.
- ▶ Money Back Guarantee!



*Ford* **Manuals.com**  
We Specialize in Classic Ford Manuals

Visit us online for other great Ford Products:

<p><b>1964</b> <b>COMET</b> and <b>FALCON</b> <b>SHOP MANUAL</b></p>	<p><b>1965</b> <b>COMET,</b> <b>FALCON,</b> <b>FAIRLANE</b> and <b>MUSTANG</b> <b>SHOP MANUAL</b></p>	<p><b>1966</b> <b>COMET,</b> <b>FALCON,</b> <b>FAIRLANE</b> and <b>MUSTANG</b> <b>SHOP MANUAL</b></p>	<p><b>1967</b> <b>COUGAR</b> <b>FAIRLANE</b> <b>FALCON</b> <b>MERCURY</b> INTERMEDIATE <b>MUSTANG</b> <b>SHOP MANUAL</b></p>
<p><b>1968</b> <b>COUGAR</b> <b>FAIRLANE</b> <b>FALCON</b> <b>MONTEGO</b> <b>MUSTANG</b> <b>SHOP MANUAL</b></p>	<p><b>1969</b> CAR <b>SHOP</b> <b>MANUAL</b> <b>VOLUME ONE</b></p> <p>FALCON FAIRLANE MUSTANG FORD THUNDERBIRD MONTEGO COUGAR METEOR MERCURY LINCOLN CONTINENTAL CONTINENTAL MARK III</p>	<p><b>1970</b> CAR <b>SHOP</b> <b>MANUAL</b> <b>VOLUME ONE</b></p> <p>METEOR MAVERICK FALCON FAIRLANE MUSTANG FORD THUNDERBIRD MONTEGO COUGAR MERCURY LINCOLN CONTINENTAL CONTINENTAL MARK III</p>	<p><b>1971</b> CAR <b>SHOP</b> <b>MANUAL</b> <b>VOLUME ONE</b></p> <p>MAVERICK TORINO MUSTANG FORD THUNDERBIRD MONTEGO COUGAR COMET METEOR MERCURY LINCOLN CONTINENTAL CONTINENTAL MARK III</p>
<p><b>1972</b> car shop manual <b>VOLUME I</b></p> 	<p><b>1973 CAR SHOP MANUAL</b></p>  <p><b>Volume 1</b> <b>Chassis</b></p>	<p><b>1965/72</b> <b>FORD CAR</b> FINAL ISSUE</p> <p>Master Parts and Accessories CATALOG</p> <p>Form FP 7635-A &amp; B</p> <p>Supersedes All Previous Issues, Changes and Revisions</p> <p>Official_FordDiagrams.com_Extract</p> <p>May, 1975</p>	<p>Blank space</p>

**100% SATISFACTION GUARANTEED**

**BUY IT NOW!**

**Click Here To Order**



*Ford* **Manuals.com**  
We Specialize in Classic Ford Manuals