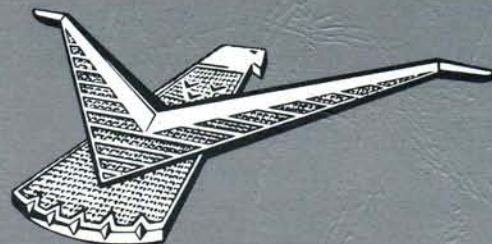


1963 FORD

*Thunderbird*



SHOP MANUAL  
SUPPLEMENT



**BUY IT NOW!**

**Click Here To Order**



PayPal

MasterCard

DISCOVER  
NOWUS

MasterCard

VISA

Copyright © 2009, Forel Publishing Company, LLC, Woodbridge, Virginia

All Rights Reserved. No part of this book may be used or reproduced in any manner whatsoever without written permission of Forel Publishing Company, LLC. For information write to Forel Publishing Company, LLC, 3999 Peregrine Ridge Ct., Woodbridge, VA 22192

## **1963 Ford Thunderbird Shop Manual**

**EAN: 978-1-60371-013-8**

**ISBN: 1-60371-013-2**

Forel Publishing Company, LLC

3999 Peregrine Ridge Ct.

Woodbridge, VA 22192

Email address: [webmaster@ForelPublishing.com](mailto:webmaster@ForelPublishing.com)

Website: <http://www.ForelPublishing.com>



This publication contains material that is reproduced and distributed under a license from Ford Motor Company. No further reproduction or distribution of the Ford Motor Company material is allowed without the express written permission of Ford Motor Company.

---

## **Note from the Editor**

This product was created from the original Ford Motor Company's publication. Every effort has been made to use the original scanned images, however, due to the condition of the material; some pages have been modified to remove imperfections.

---

## **Disclaimer**

Although every effort was made to ensure the accuracy of this book, no representations or warranties of any kind are made concerning the accuracy, completeness or suitability of the information, either expressed or implied. As a result, the information contained within this book should be used as general information only. The author and Forel Publishing Company, LLC shall have neither liability nor responsibility to any person or entity with respect to any loss or damage caused, or alleged to be caused, directly or indirectly by the information contained in this book. Further, the publisher and author are not engaged in rendering legal or other professional services. If legal, mechanical, electrical, or other expert assistance is required, the professional should be sought.



# 1963 FORD THUNDERBIRD

## SHOP MANUAL SUPPLEMENT

### GROUP INDEX

THUNDERBIRD IDENTIFICATION

ENGINE AND EXHAUST SYSTEM

1

IGNITION SYSTEM

2

FUEL SYSTEM

3

COOLING SYSTEM

4

CRUISE-O-MATIC TRANSMISSION

5

REAR AXLE AND DRIVE LINE

6

STEERING

7

BRAKES AND SUSPENSION

8

GENERATING AND STARTING  
SYSTEMS

9

LIGHTS, INSTRUMENTS AND  
ACCESSORIES

10

BODY

11

MAINTENANCE, LUBRICATION  
AND SPECIAL TOOLS

12

SPECIFICATIONS

13



**BUY IT NOW!**

**Click Here To Order**



MENT  
ION  
PANY

1962

IN, MICHIGAN

Reprinted with Ford Motor Company's Permission

## FOREWORD

*The information in this supplement, when used with the 1962 Ford Thunderbird Shop Manual, provides the necessary information for servicing the 1963 Thunderbird. Complete 1963 maintenance information and specifications are included.*

*The descriptions and specifications contained in this supplement were in effect at the time the manual was approved for printing. The Ford Division of Ford Motor Company reserves the right to discontinue models at any time, or change specifications or design, without notice and without incurring obligation.*

**SERVICE DEPARTMENT  
FORD DIVISION  
FORD MOTOR COMPANY**



**BUY IT NOW!**  
**Click Here To Order**



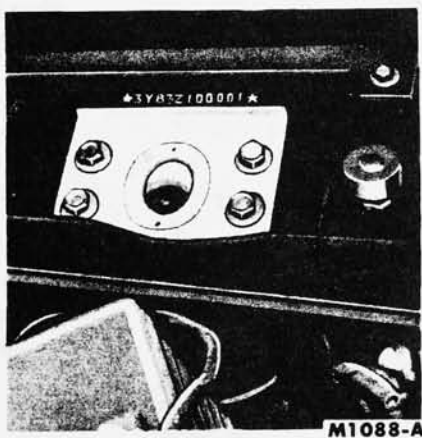
# THUNDERBIRD IDENTIFICATION



**FIG. 1—Thunderbird Warranty Plate**

Figure 1 illustrates a Thunderbird Warranty plate and its elements. The Warranty plate is attached to the left door front pillar.

The official Vehicle Identification number for title and registration purposes is stamped on the body just forward of the right-hand hood lock plate (Fig. 2). Do not use the Vehicle Warranty number which appears on the Warranty plate for title or registration purposes.



**FIG. 2—Vehicle Identification Number Location**

**VEHICLE DATA**

Example (Fig. 1):

63A	J	85	9H	11	1	4	
63A	.....						Tudor Hardtop
	.....						Red
	.....						Red Leather
	.....						Ninth day of August
	.....						District Code
	.....						3.00:1 Axle Ratio
	.....						Cruise-O-Matic

**100% SATISFACTION GUARANTEED**

**BUY IT NOW!**

**Click Here To Order**

**BODY**

63A	.....	Tudor Hardtop
76A	.....	Tudor Convertible

**COLOR**

If a special paint is used, the paint color space will not be stamped.

**M30J/M32J**

Code	Number	Color	Sales Name
A	1724	Black	Raven Black
D	1070	Med. Turquoise Metallic	Patrician Green
E	1269	Med. Blue Metallic	Acapulco Blue
G	1446	Silver Blue Metallic	Silver Mink
H	1544	Dark Blue Metallic	Caspian Blue
J	1515	Red	Rangoon Red
K	1452	Lt. Turquoise	Chalfonte Blue
L	1458	Pink	Sahara Rose
M	1238	White	Corinthian White
N	921	Diamond Blue	Diamond Blue
O	1554	Med. Green Metallic	Green Mist
R	1456	Yellow	Tucson Yellow
S	1453	Dk. Green Metallic	Cascade Green
T	1543	Lt. Beige	Sandshell Beige
U	1450	Dark Turquoise Metallic	Deep Sea Blue
V	1470	Chestnut Metallic	Chestnut
W	1555	Lt. Pink Metallic	Rose Beige
X	1444	Maroon Metallic	Heritage Burgundy
Z	1427	Beige Metallic	Fieldstone Tan

**TRIM**

Deviation trim sets will use existing trim codes plus a suffix. A trim code with a numerical suffix is not serviced, while a trim code with an alphabetical suffix is serviced.

Code	Crinkle Vinyl	Pin Stripe B/C
72	Lt. Blue D/L	Dk. Blue
77	Lt. Turquoise D/L	Dk. Turquoise
74	Pearl Beige	Med. Beige
76	Black	Black

Code	Crinkle Vinyl	Vachette Vinyl
52.....	Med. Blue D/L.....	Lt. Blue D/L.....
57.....	Med. Turquoise D/L.....	Lt. Turquoise D/L.....
59.....	Med. Chestnut D/L.....	Med. Chestnut D/L.....
54.....	Pearl Beige.....	Pearl Beige.....
56.....	Black.....	Black.....
55.....	Red.....	Red.....
50.....	Med. Silver Blue Met.....	Lt. Silver Blue D/L.....
58.....	Lt. Gold D/L.....	Lt. Gold D/L.....
51.....	Lt. Rose Beige D/L.....	Lt. Rose Beige D/L.....

Code	Crinkle Leather	Vachette Leather
82.....	Lt. Blue D/L.....	Lt. Blue D/L.....
84.....	Pearl Beige.....	Pearl Beige.....
86.....	Black.....	Black.....
85.....	Red.....	Red.....

**DATE**

The code letters for the month are preceded by a numeral to show the day of the month when the Thunderbird was completed. The second year code letters are to be used if model production exceeds 12 months.

Month	First Model Year	Second Model Year
January.....	A.....	N.....
February.....	B.....	P.....
March.....	C.....	Q.....
April.....	D.....	R.....
May.....	E.....	S.....
June.....	F.....	T.....
July.....	G.....	U.....
August.....	H.....	V.....
September.....	J.....	W.....
October.....	K.....	X.....
November.....	L.....	Y.....
December.....	M.....	Z.....

**DSO**

Thunderbirds built to a Domestic Special Order, Foreign Special Order, or Pre-Approved Order have the complete order number recorded in this space. Also appearing in this space is the two digit code number of the District which ordered the unit. If the unit is regular production, only the District code number will appear.

**DISTRICT CODE**

Code	District	Code	District
11.....	Boston	45.....	Davenport
12.....	Buffalo	51.....	Denver
13.....	New York	52.....	Des Moines
14.....	Pittsburgh	53.....	Kansas City
15.....	Newark	54.....	Omaha
21.....	Atlanta	55.....	St. Louis
22.....	Charlotte	61.....	Dallas
23.....	Philadelphia	62.....	Houston
24.....	Jacksonville	63.....	Memphis
25.....	Richmond	64.....	New Orleans
26.....	Washington	65.....	Oklahoma City
31.....	Cincinnati	71.....	Los Angeles
32.....	Cleveland	72.....	San Jose
33.....	Detroit	73.....	Salt Lake City
.....	Indianapolis	74.....	Seattle
.....	Lansing	81.....	Ford of Canada

**AXLE**

Code	Ratio
1.....	3.00:1
A*.....	3.00:1

\*Equa-Lock Type.

**TRANSMISSION**

Code	Type
4.....	Cruise-O-Matic

**VEHICLE WARRANTY NUMBER**

Example (Fig. 1): 3Y83Z100001

3.....	1963 Model
Y.....	Wixom Assembly Plant
83.....	Tudor Hardtop
Z.....	8-Cylinder 390 Cubic Inch Engine
100001.....	First Unit Built

**MODEL YEAR**

The number "3" designates 1963.

**ASSEMBLY PLANT**

Code	Location
Y.....	Wixom Assembly Plant
S.....	Pilot Plant

**MODEL**

Code	Type
83.....	Tudor Hardtop
85.....	Tudor Convertible
87.....	Tudor Landau
89.....	Tudor Roadster

**ENGINE**

Code	Type
M.....	8-Cylinder 390 Cubic Inch (6-barrel High Performance)
9.....	8-Cylinder 390 Cubic Inch (4-barrel Low Compression Export, 84 Octane)
Z.....	8-Cylinder 390 Cubic Inch (4-barrel)

**CONSECUTIVE UNIT NUMBER**

The assembly plant, with each model year, begins with consecutive unit number 100001 and continues on for each unit built.



**BUY IT NOW!**

**Click Here To Order**



## GROUP 1—ENGINE AND EXHAUST SYSTEM

The 1963 maintenance recommendations are in Group 12 and the 1963 specifications are in Group 13 of this manual.

All the service procedures outlined in Group 1 of the 1962 Shop Manual apply for both the 1963 390 4-V engine and the 390 6-V High Performance engine with the following exceptions.

### 390 4-V ENGINE (Part 1-1)

#### CAMSHAFT

The camshaft and related parts are shown in Fig. 3.

##### Removal

1. Refer to "Valve Rocker Arm Shaft Assembly Removal" (page 1-15, 1962 Shop Manual) and remove the valve rocker arm shaft assemblies.

2. Remove the cylinder front cover following steps 1 thru 16 under "Cylinder Front Cover and Timing Chain Removal" (page 1-23, 1962 Shop Manual).

3. Remove the valve push rods in sequence and place them in a rack so that they can be installed in their original positions.

4. Position an inspection light through a push rod opening and into the valve push rod valley (Fig. 55, page 1-26, 1962 Shop Manual). Remove the valve lifters with a magnet through the push rod openings. In some cases, it will be necessary to

transfer the lifter over to an adjoining push rod opening in order to remove it. Place the lifters in a rack so that they can be installed in their original positions.

5. Install a dial indicator so the indicator point is on the camshaft sprocket retaining screw. Push the camshaft toward the rear of the engine and set the dial indicator on zero. Pull the camshaft forward and release it. Compare the indicator reading with the specifications. If the end play is excessive, check the spacer for correct installation before it is removed. **The side of the spacer having a chamfer on the ID must be against the camshaft front journal.** If the spacer is installed correctly, replace the thrust plate.

6. Remove the dial indicator. Remove the camshaft sprocket cap screw, lock washer, flat washer, and fuel pump eccentric.

7. Slide both sprockets and the timing chain forward, and remove the sprockets and timing chain as an assembly (Fig. 49, 1962 Shop Manual).

8. Remove the oil pan and oil pump by following the procedure under "Oil Pan and Oil Pump Removal" (page 1-32, 1962 Shop Manual).

9. Remove the camshaft thrust plate and spacer. Carefully remove the camshaft by pulling it toward the front of the engine. **Use caution to avoid damaging the camshaft bear-**

ings.

##### Installation

1. Oil the camshaft and apply Lubriplate to the lobes. Carefully slide the camshaft through the bearings. Install the thrust plate. Install the thrust plate with the side having a chamfered ID against the camshaft front journal. **The oil groove in the thrust plate must be above the camshaft, and it must face towards the front (against the camshaft sprocket).**

2. Follow step 5 under "Camshaft Removal" and check the camshaft end play.

3. Position the sprockets and timing chain on the camshaft and crankshaft with the timing marks on the sprockets aligned as shown in Fig. 48, page 1-24, 1962 Shop Manual.

4. Install the fuel pump eccentric, flat washer, lock washer, and sprocket cap screw. Torque the sprocket cap screw to specifications. Install the front oil slinger.

5. Replace the crankshaft front oil seal. Install the cylinder front cover, the crankshaft damper, and related parts following steps 3 thru 16 under "Cylinder Front Cover and Timing Chain Installation" (page 1-24, 1962 Shop Manual).

6. With No. 1 piston on TDC at the end of the compression stroke, position the distributor in the block with the rotor at the No. 1 firing position and the points open. Install the hold down clamp.

7. Connect the distributor vacuum line. Install the distributor cap. Connect the coil high tension lead.

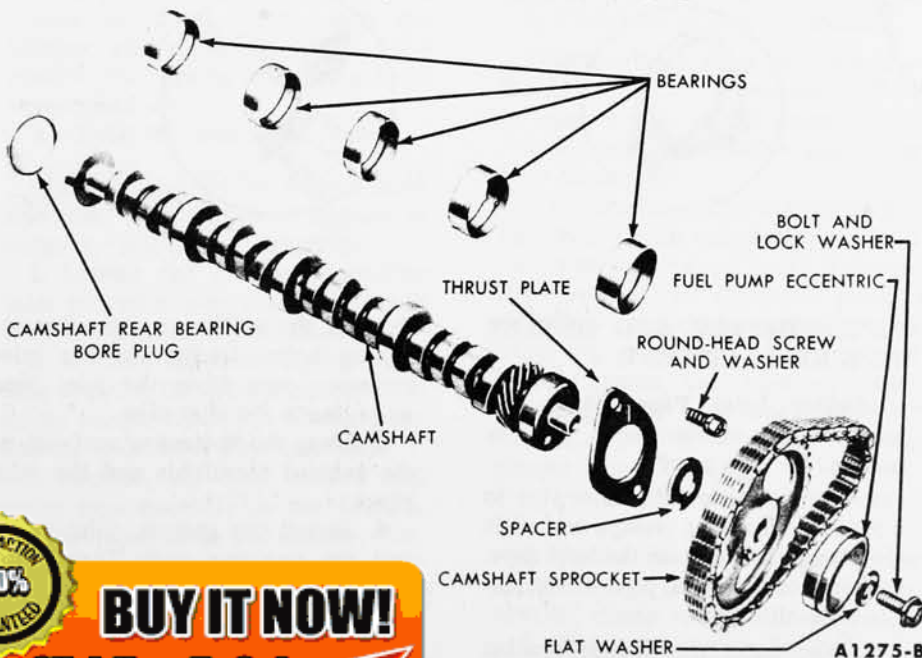
8. Install the valve lifters in the bores from which they were removed. Install the push rods.

9. Refer to "Valve Rocker Arm Shaft Assembly Installation" and install the valve rocker arm shaft assembly following steps 1 thru 9, page 1-16, 1962 Shop Manual.

10. Fill and bleed the cooling system. Fill the crankcase with the proper grade and quantity of engine oil.

11. Start the engine and check and adjust the ignition timing. Operate the engine at fast idle and check all hose connections and gaskets for leaks.

**Cleaning and Inspection.** Refer to the 1962 Shop Manual for cleaning and inspection procedures.



**100% SATISFACTION GUARANTEED**

**BUY IT NOW!**

**Click Here To Order**

ts

PayPal

MasterCard

VISA

### 390 6-V HIGH PERFORMANCE ENGINE (Part 1-1)

The warranty plate identification symbol for the engine is "M". This engine is the same as the 390 4-V engine except for specifications (Group 13) and the following differences:

1. A cast aluminum intake manifold replaces the cast iron intake manifold used on the 390 4-V engine.
2. The coolant-heated carburetor

spacer is eliminated.

3. The exhaust gas control valve is mounted with the counterweight on the outboard side of the engine.

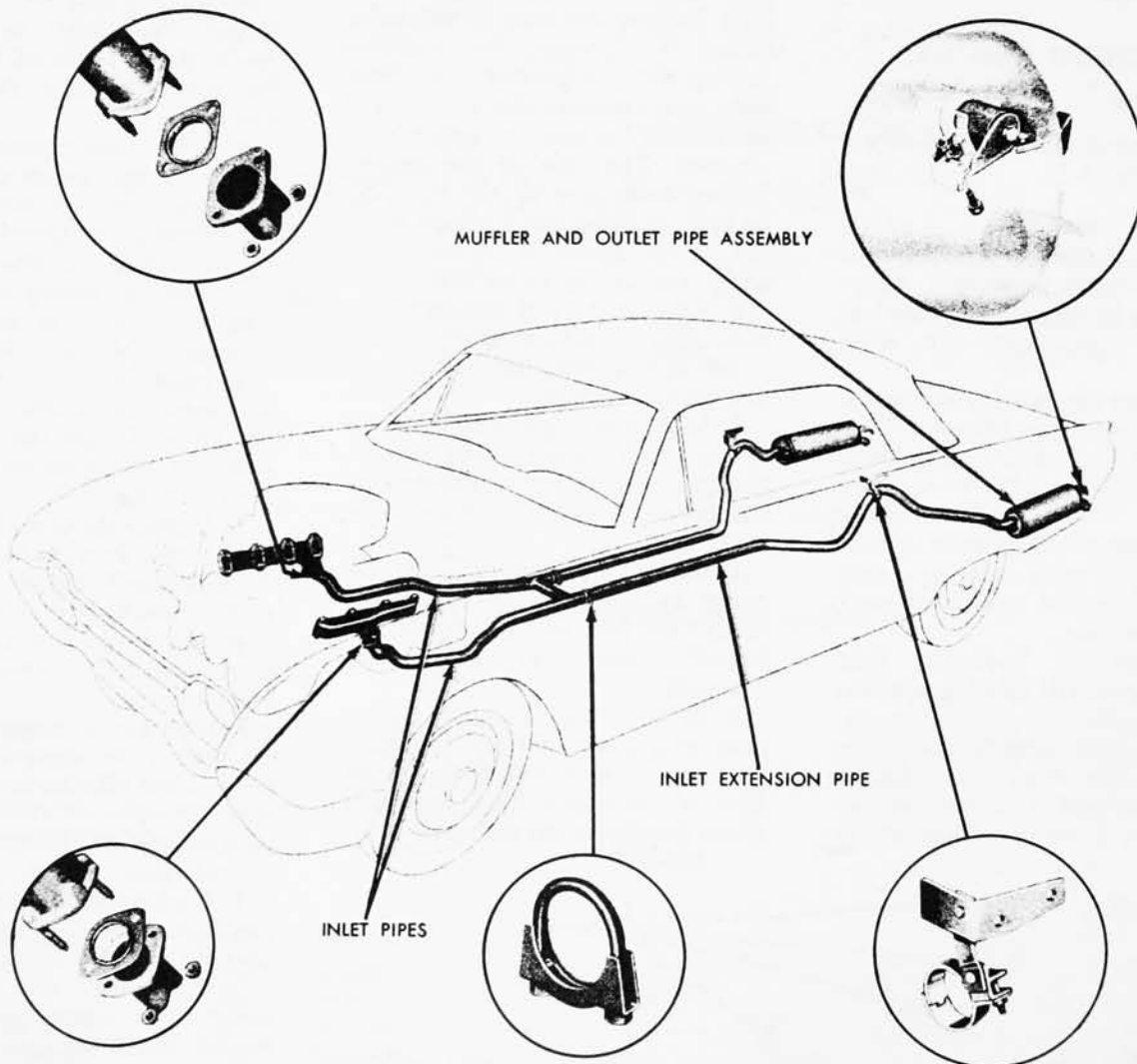
### EXHAUST SYSTEM (Part 1-2)

#### DESCRIPTION

A single exhaust system is standard equipment on all 1963 Thunderbirds. A dual exhaust system is available as optional equipment on

all models.

The dual exhaust system (Fig. 3A) consists of: a one-piece muffler inlet pipe with separate front section inlet pipes that are joined together by a welded cross-over pipe; separate right and left inlet extension pipes; right and left mufflers that contain integral muffler outlet pipes; retaining clamps, brackets, nuts and bolts; two exhaust manifolds to inlet pipe gaskets.



A1730-A

**FIG. 3A—Dual Exhaust System**

The single exhaust system (Fig. 3B) consists of: a one-piece muffler inlet pipe with "Y" type inlet pipes that are joined and welded together; a muffler with an integral outlet pipe; a muffler inlet extension pipe; retaining clamps, brackets, bolts and exhaust manifolds to inlet

### PIPE, MUFFLER AND OUTLET PIPE REPLACEMENT

**Muffler Inlet Pipe—Dual Exhaust.** The muffler inlet pipe is serviced in one piece.

1. Loosen the muffler inlet pipe to inlet extension pipe clamps and slide the clamps forward on the inlet pipe. Disconnect the inlet pipe at the exhaust manifolds.

2. Disconnect the hanger bracket clamp from the inlet extension pipe.

Remove the muffler rear bracket retaining bolts. Disconnect the inlet extension pipe from the inlet pipe and remove the inlet pipe.

3. Clean the mounting surfaces of the exhaust manifolds and the inlet pipes.

4. Install the gaskets, inlet pipes, and the retaining nuts. Torque the nuts to specifications.

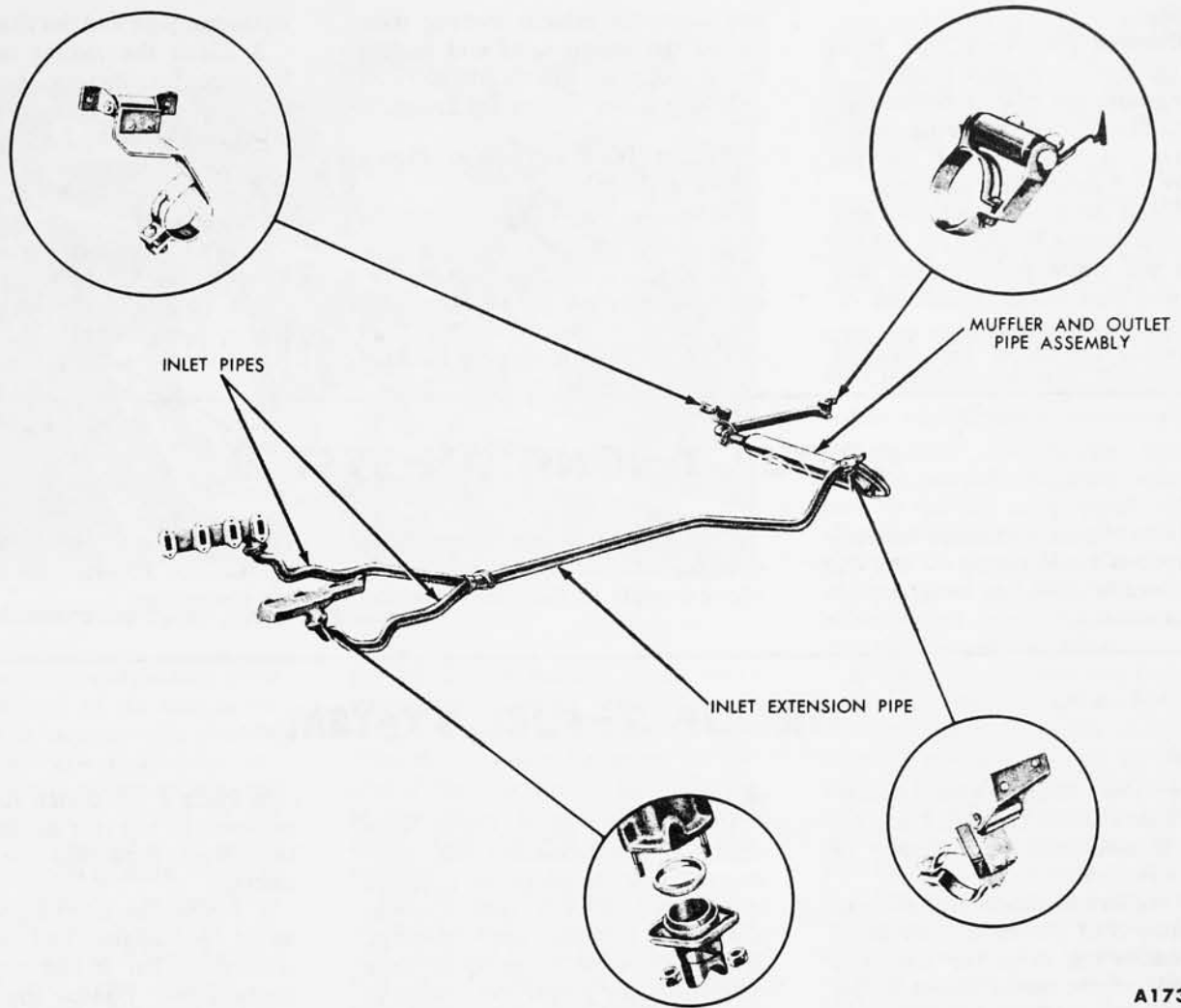
5. Position the front clamp on the inlet extension pipe. Connect the inlet pipe and the inlet extension pipe;

**100% SATISFACTION GUARANTEED**

**BUY IT NOW!**

**Click Here To Order**

PayPal    American Express    Discover    MasterCard    VISA



A1731-A

**FIG. 3B—Single Exhaust System**

then install the muffler, muffler rear bracket retaining bolts, and the inlet extension bracket clamp.

6. Align the exhaust system; then, torque the front clamp, inlet extension pipe bracket clamp, and muffler rear bracket retaining bolts to specifications.

7. Check the system for leaks.

**Muffler and Outlet Pipe – Dual Exhaust.** The procedure applies to either a right or left assembly.

1. Loosen the muffler to muffler inlet extension pipe clamp and slide it forward on the extension pipe.

2. Remove the retaining bolts and nuts securing the muffler rear bracket to the hanger assembly. Remove the muffler and outlet pipe assembly.

3. Position the new muffler and outlet pipe assembly on the inlet extension pipe. Slide the muffler for-

ward on the inlet extension pipe. Install the muffler inlet extension pipe front clamp and the muffler rear bracket retaining bolts and nuts. Torque the clamp and bolts to specifications.

5. Check the system for leaks.

**Muffler Inlet Pipe Extension – Dual Exhaust.** The procedure applies to either a right or left assembly.

1. Remove the muffler and outlet pipe assembly.

2. Loosen the muffler inlet extension pipe front clamp and remove the inlet extension pipe hanger bracket clamp. Remove the inlet extension pipe.

3. Position the inlet extension pipe front clamp on the end of the inlet pipe. Connect the inlet extension pipe to the inlet pipe. Install the inlet extension pipe front clamp and the hanger bracket clamp.

4. Install the muffler and outlet pipe assembly.

5. Torque the inlet extension pipe front and rear clamps and the hanger bracket clamp to specifications.

6. Check the system for leaks.

**Muffler Inlet Pipe – Single**

**Exhaust.** The muffler inlet pipe is serviced as one piece.

1. Remove the retaining bolts and nuts from the inlet pipe to inlet extension pipe flange. Remove the clamp from the inlet extension pipe hanger bracket.

2. Disconnect the inlet pipes at the exhaust manifold. Remove the inlet pipe and gaskets from the exhaust manifolds.

3. Clean the mounting surfaces of the exhaust manifolds and the inlet pipes. Install the gaskets, inlet pipes, and retaining nuts. Torque the nuts to specifications.

4. Install a new gasket between the inlet pipe and the inlet pipe extension flange. Install the flange retaining bolts and nuts; then, torque them to specifications.

5. Install the inlet extension pipe hanger bracket clamp and torque the retaining nuts to specifications.

6. Check the system for leaks.

**Muffler – Single Exhaust.** The muffler and outlet pipe is serviced as

**100% SATISFACTORY GUARANTEED**

**BUY IT NOW!**

**Click Here To Order**

PayPal   American Express   Discover   MasterCard   VISA

one piece.

1. Remove the outlet pipe front and rear hanger bracket clamps.

2. Remove the inlet extension pipe to muffler flange retaining bolts. Remove the flange gasket and the muffler and outlet pipe assembly.

3. Clean the muffler and inlet pipe extension flanges. Position the muffler flange and a new gasket on the inlet extension pipe flange. Install the retaining bolts and nuts.

4. Install the outlet pipe clamps

and align the exhaust system; then, torque the clamp bolts and muffler flange bolts to specifications.

5. Check the system for leaks.

#### Muffler Inlet Extension Pipe – Single Exhaust

1. Remove the flange bolts from both flanges of the inlet extension pipe. Remove the clamp from the extension pipe hanger bracket.

2. Pry the muffler toward the right side of the car and remove the inlet

extension pipe and the flange gaskets.

3. Clean the mating surfaces of the mounting flanges; then, position the inlet extension pipe on the inlet pipe and muffler flanges. Insert a new gasket between the front and the rear flanges. Install the mounting bolts and nuts.

4. Install the inlet extension pipe hanger bracket clamp. Torque the flange bolts and the hanger clamp bolt to specifications.

5. Check the system for leaks.

## GROUP 2—IGNITION SYSTEM

The 1963 maintenance recommendations are in Group 12 and the 1963 specifications are in Group 13 of this manual.

The ignition system service procedures outlined in the 1962 Shop Manual apply to the 1963 Thunder-

bird. Refer to Group 2 of the 1962 manual for the recommended service procedures.

## GROUP 3—FUEL SYSTEM

The 1963 maintenance recommendations are in Group 12 and the 1963 specifications are in Group 13 of this manual.

All the service procedures outlined in Group 3 of the 1962 Shop Manual remain the same for the 1963 390 4-V engine series except as described herein (Ford 4-V carburetor). Service procedures for the 1963 High Performance 390 6-V engine series (three Holley dual carburetors) are included in this supplement.

### FORD 4-BARREL CARBURETOR

#### OPERATION

The carburetor incorporates the following changes:

1. A magnet and bracket assembly was added to the front wall of the carburetor air horn to entrap the choke plate in the closed position and increase the force holding the choke plate closed during cold engine starting.

2. A lower torque rate choke housing spring has been incorporated to reduce the forces tending to close the choke plate after the engine has started, thereby minimizing the tendency of the carburetor to over-choke the engine and cause "loading".

The external vent opening has

period.

4. Standpipe pitot tubes were added to the secondary fuel bowl internal vent openings to raise the level of the internal vent openings above the external vent openings. This provides the necessary pressure differential for proper evacuation of the gaseous vapors through the external vent during a hot soak period.

5. Two baffles have been added in the internal fuel equalizer passage between the primary and secondary fuel bowls to permit proper control of the metering forces within each fuel bowl, since these forces were thrown out of balance by the addition of the secondary fuel bowl external vent.

6. The calibration of the secondary section of the carburetor was revised to compensate for the reduction in the metering forces. Refer to the specifications for the proper metering jets.

#### IN-CHASSIS ADJUSTMENT

**Automatic Choke.** Use the following procedure to adjust the magnet and bracket assembly:

1. Rotate the choke thermostat coil housing 90° in the "rich" direction (counterclockwise).

2. Adjust the bellcrank lever, if necessary, to obtain 0.050 inch between the top edge of the fast idle cam and the cast stop boss on the rear of the choke housing.

3. Place a 0.010-inch feeler gauge between the top rear straight edge of the choke plate and the air horn casting.

4. Loosen the attaching screws and adjust the magnet and bracket assembly so that it just contacts the choke plate. Tighten the attaching screws and remove the feeler gauge. Set the choke thermostat coil housing to the proper index mark. All other procedures for adjusting the automatic choke are the same as outlined in Part 3-1 of the 1962 Thunderbird Shop Manual.

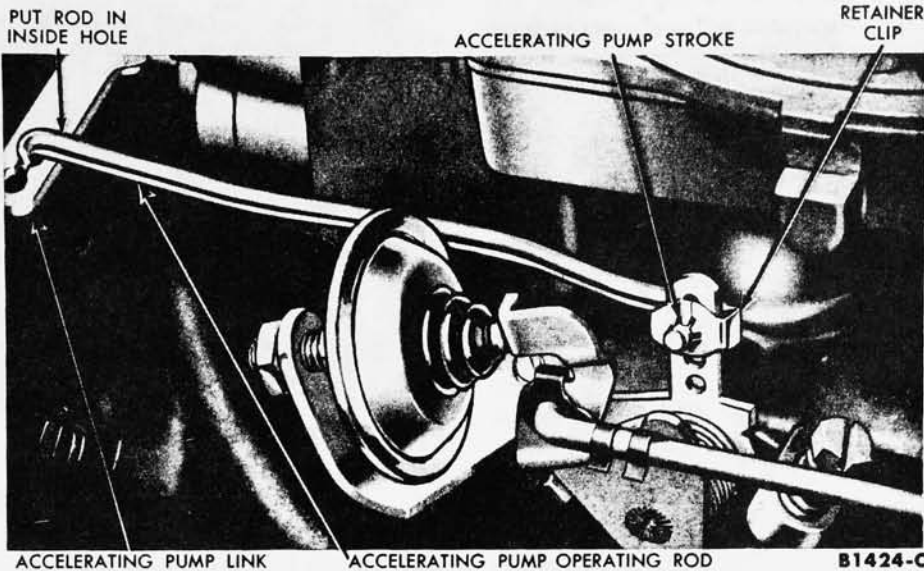
**Fuel Level Float Adjustment.** On carburetors equipped with Viton-tipped fuel inlet needles, the dry float fuel level settings should be used as a guide only, and a final check and adjustment of the wet fuel level should be made as follows:

1. Operate the engine for 30 minutes at 1200 rpm to normalize engine temperatures, and place vehicle on a flat surface as near level as possible. Stop the engine.

2. Remove the air cleaner assembly, carburetor air horn assembly, and gasket.

3. Temporarily place the air horn gasket in position on the carburetor main body and start the engine. Let the engine idle for several minutes; then remove the air horn gasket.

4. While the engine is idling, use a standard depth scale to measure the vertical distance from the top ma-



**FIG. 4—Accelerating Pump Stroke Adjustment**

chined surface of the carburetor main body to the level of the fuel in the fuel bowl. The measurement must be made at least 1/4 inch from any vertical surface to assure an accurate reading because the surface of the fuel is concave (higher at the edges than in the center). Care must be exercised to measure the fuel level at the point of contact with the fuel. Refer to the specifications for the correct fuel level (wet) setting.

5. If any adjustment is required, stop the engine to minimize the hazard of fire due to fuel spray when the float setting is disturbed. To adjust the fuel level, bend the float tab contacting the fuel inlet valve upward, in relation to the original position, to raise the fuel level and downward to lower it. Each time an adjustment is made to the float tab to alter the fuel level the engine must be started and permitted to idle for at least three (3) minutes to stabilize the fuel level. Check the fuel level after each adjustment until the specified level is achieved.

6. Install a new air horn gasket and the carburetor air horn assembly.

7. Check the engine idle speed and idle fuel mixture and adjust as required.

8. Install the air cleaner assembly.

**Accelerating Pump Stroke.** The over-travel lever has 4 holes and the accelerating pump link has 2 holes

the No. 2 hole position of the over-travel lever (second hole from the throttle shaft). **To release the rod from the retainer clip, press the tab end of the clip toward the rod, and at the same time press the rod away from the clip until it is disengaged.**

For low ambient temperature operation (below 40°F), place the pump operating rod in the No. 3 hole position of the over-travel lever (third hole from the throttle shaft).

For extremely low ambient temperature operation (-15°F and below), the pump operating rod may be placed in the No. 4 hole position to suit individual operating conditions.

For high ambient temperature operation (above 80°F and/or above 5000 feet altitude), the pump oper-

ating rod may be placed in the No. 1 hole position of the over-travel lever (hole closest to the throttle shaft) to suit individual operating conditions.

The correct position for the pump operating rod at the accelerator pump plunger lever, for all operating conditions, is in the inboard hole (hole closest to the pump plunger).

**HOLLEY DUAL CARBURETORS IN-CHASSIS ADJUSTMENTS**

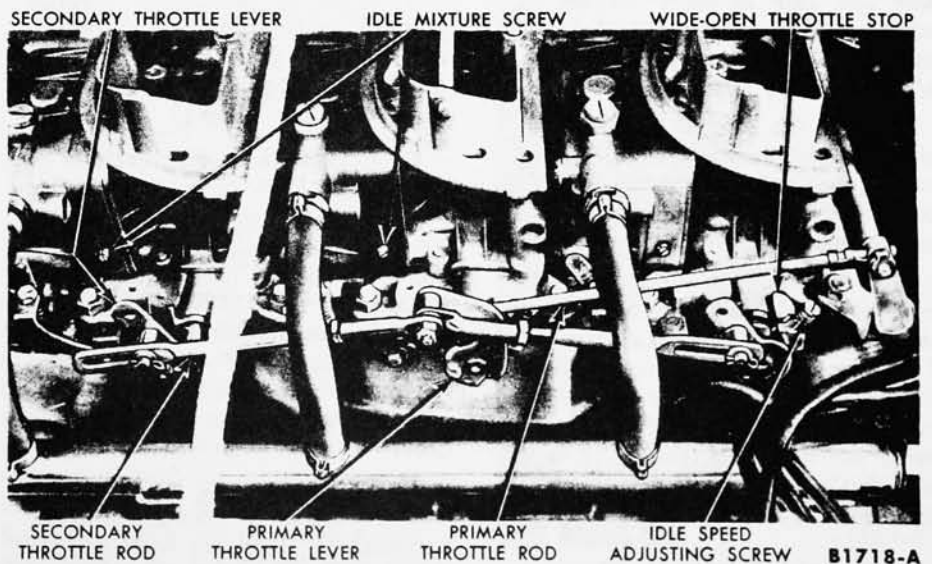
**Idle Fuel Mixture Adjustment**

1. Operate the engine until it reaches normal operating temperature. If the car is equipped with an air conditioner, the engine must be operated at least 20 minutes. **All engine speed and idle fuel mixture adjustments must be made with the air cleaner installed.**

2. Establish an initial idle fuel mixture adjustment by turning both idle mixture screws on each carburetor (Fig. 5) inward until they are lightly seated. Then turn the idle mixture screws on each secondary carburetor (Fig. 6) outward 3/4 turns, and turn the primary carburetor idle mixture screws outward one full turn.

3. Install an engine speed tachometer. Start the engine; move the transmission selector lever to the DRIVE (D1) position, and set the parking brake. Adjust the engine idle rpm to 575-600 rpm by turning the idle speed adjusting screw (Fig. 5) on the primary carburetor only.

4. Turn the primary carburetor idle mixture screws inward until the engine begins to run rough from the lean mixture. Turn the mixture screws outward until the engine be-



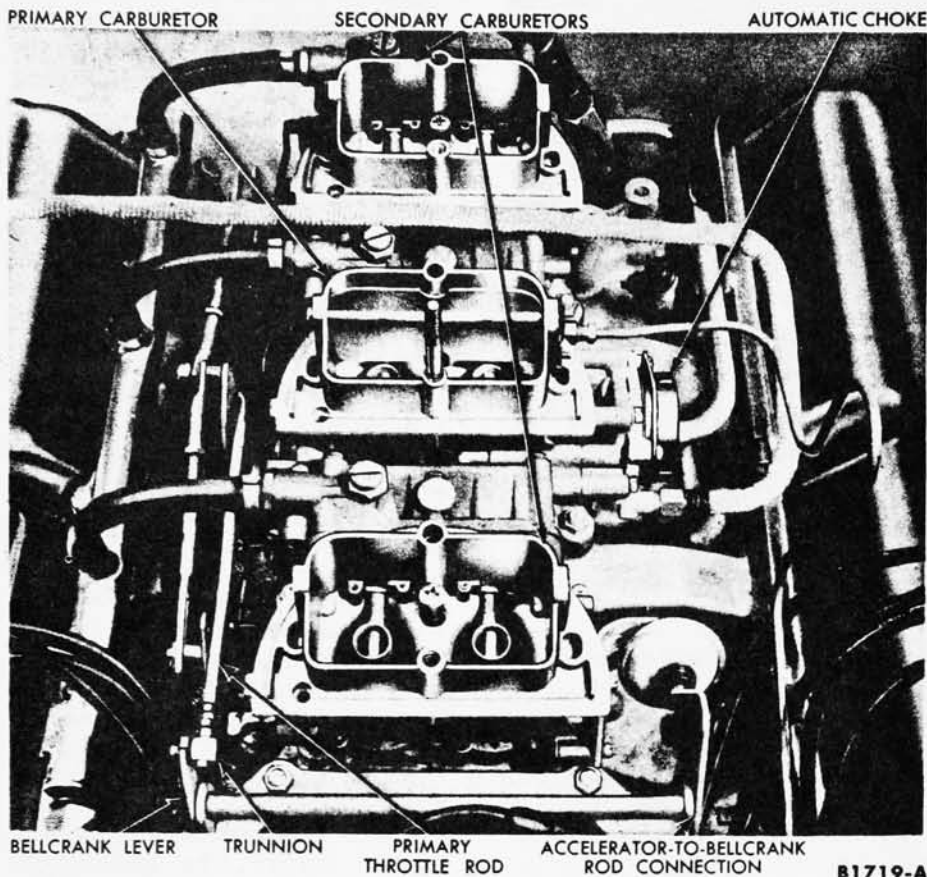
**FIG. 5—390 6-V Carburetor Throttle Linkage Installation**

**100% SATISFACTION GUARANTEED**

**BUY IT NOW!**

**Click Here To Order**

PayPal, American Express, Discover, MasterCard, VISA



**FIG. 6—390 6-V Carburetor Installation**

gins to roll from the rich mixture. Turn the screws inward until the engine runs smoothly and evenly. Always favor a slightly "rich" idle fuel mixture.

5. Repeat this procedure (step 4) to adjust the idle mixture screws on the front secondary carburetor.

6. Following the same procedure, adjust the idle mixture screws on the rear secondary carburetor. **The right and left idle mixture screws on any one carburetor should be open an equal amount, within 1/8 turn, after the final adjustment.**

7. With the engine operating at idle and the transmission in Drive range, check the engine speed. The tachometer should indicate 575-600 engine rpm.

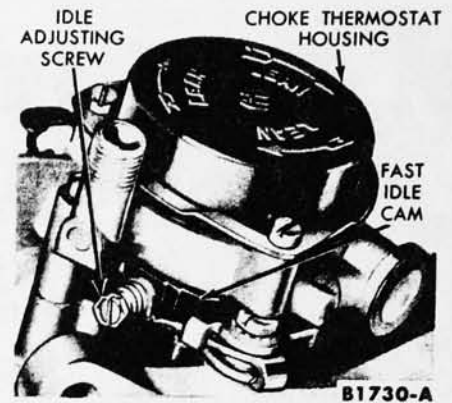
8. If the engine still does not idle properly, due to a too rich mixture, i.e., idle mixture screws are seated, it may be caused by improper initial idle speed setting of the secondary carburetor. Also, if the throttle

ments must be made with the air cleaner installed and the engine at normal operating temperature.

1. Back off the idle speed adjusting screw (Fig. 5) on each secondary carburetor sufficiently to allow the throttle plates to seat in the throttle bores. Turn the idle speed screws inward until the screw end just touches the stop on the throttle lever; then turn it inward an additional 1/2 to 3/4 turns. **A minimum throttle opening is desired on the secondary throttle plates. The only requirement necessary is that the plates do not stick in the bores.**

2. Operate the engine for 30 minutes at 1200 rpm to normalize engine temperatures. Install an engine speed tachometer. Start the engine. Move the transmission selector lever to the DRIVE (D1) position, and set the parking brake. Adjust the engine idle rpm to 575-600 rpm by turning the idle speed adjusting screw on the primary carburetor only.

3. Set the fast idle speed (cold) with the engine at normal operating temperature. Align the high step on the fast idle cam with the adjusting screw (Fig. 7). Turn the screw in-



**FIG. 7—Fast Idle Speed Adjustment**

ward to increase or outward to decrease the idle speed to obtain the specified rpm.

**Throttle Lever Synchronization.** If the throttle linkage is disassembled or it is improperly synchronized, the following procedure is recommended for synchronizing the throttle levers on the three carburetors.

1. Insert a 1/8-inch diameter rod through the gauging holes (Fig. 8) provided in the bellcrank lever and mounting bracket on the left side of the bellcrank assembly. This locks the lever in the gauging (closed throttle) position.

2. Disconnect the secondary throttle rods at each secondary carburetor throttle lever (Fig. 5). Disconnect the primary throttle rod at the bellcrank lever.

3. Loosen the lock nut and adjust the length of the front secondary carburetor throttle rod so that, when installed, the throttle lever of the front secondary carburetor will be completely closed when the primary throttle lever is closed against the idle speed adjusting screw stop (normal idle position).

4. Adjust the length of the rear secondary carburetor throttle rod in the same manner.

5. Install the secondary throttle rods on the secondary throttle levers with the spacer washers and retainers. Tighten the lock nuts to secure the adjustment.

6. With the primary throttle lever against the idle stop, adjust the length of the primary throttle rod (Fig. 6), so that the trunnion will just engage in the hole in the bellcrank lever. Install the rod retainer clip.

7. Adjust the anti-stall dashpot clearance.

id

**100% SATISFACTION GUARANTEED**

**BUY IT NOW!**

**Click Here To Order**

sp

PayPal

MasterCard

VISA



**FIG. 8—Anti-Stall Dashpot Adjustment**

**Anti-Stall Dashpot Adjustment**

1. Adjust the engine idle speed and idle fuel mixture, and synchronize the carburetor linkage. Operate the engine until it reaches normal operating temperature.

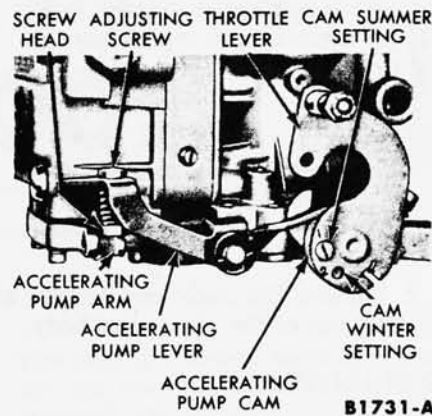
2. Lock the throttle linkage in the gauging position by inserting a 1/8-inch diameter rod through the gauging holes provided in the bellcrank lever and mounting bracket on the left side of the bellcrank assembly (Fig. 8).

3. Loosen the lock nut and turn the anti-stall dashpot screw in, or away from the bellcrank lever. Fully depress the dashpot plunger with a screwdriver blade, and adjust the clearance between the plunger and bellcrank lever to 1/8-3/16 inch. Tighten the locknut and remove the 1/8-inch rod from the gauge holes.

**Automatic Choke Adjustment.** The automatic choke has an adjustment to control its reaction to engine temperature. By loosening the three screws that retain the choke thermostat housing (Fig.7), it can be turned to alter the thermostatic spring adjustment. Turning the housing in a counterclockwise direction provides a richer mixture, and conversely, a leaner mixture is obtained by turning the housing in a clockwise direction as indicated by the arrows on the housing. Refer to the specifications for the proper setting.

the adjusting screw into the screw head to increase the clearance and outward to decrease the clearance. One-half turn of the screw equals approximately 0.015 inch.

To satisfy acceleration requirements in various climates, the accelerating pump cam can be placed in either of two positions. Aligning the top hole of the cam with the top hole of the throttle lever gives the shortest stroke which is recommended for warm weather or average conditions. Aligning the cam bottom hole with the lever bottom hole gives the longest stroke which is recommended for cold weather operation.



**FIG. 9—Accelerating Pump Adjustment**

**Fuel Level Check.** Position the car on a level floor. Be sure the fuel pump pressure is within specifications. Operate the engine for 30 minutes at 1200 rpm until normal operating temperature has been reached. Place a suitable container below the fuel level sight plug to collect any spill-over of fuel.

With the engine stopped, remove the fuel level sight plug and gasket and check the fuel level (Fig. 10). The fuel level within the bowl should be at the lower edge of the sight plug opening  $\pm 1/16$  inch.

If the fuel level is satisfactory, install the sight plug. Do not install the air cleaner at this time.

If the fuel level is too high, drain the fuel bowl and refill it and check it again before altering the float setting. This will eliminate the possibility of foreign material causing a temporary flooding condition. To drain the fuel bowl, remove one lower retaining bolt from the fuel bowl and drain the fuel into a suitable container. Install the bolt and start the engine to fill the fuel bowl.

After the fuel level has stabilized, stop the engine and check the fuel level.

**Float Adjustment**

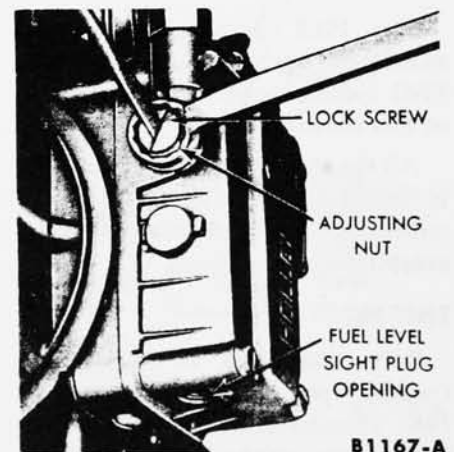
1. If the fuel level is too high, it should first be lowered below specifications and then raised until it is just at the lower edge of the sight plug opening. If the fuel level is too low, it is only necessary to raise it to the specified level; thus omit steps 3 and 4 of this procedure.

2. **With the engine stopped,** loosen the lock screw on top of the fuel bowl just enough to allow rotation of the adjusting nut underneath (Fig. 10). **Do not loosen the lock screw or attempt to adjust the fuel level with the engine running because the pressure in the line will spray fuel out and present a fire hazard.**

3. Turn the adjusting nut approximately 1/2 turn in to lower the fuel level below specifications (1/6 turn of the adjusting nut, depending on the direction of rotation, will raise or lower the float assembly at the fuel level sight plug opening 3/64 inch).

4. Tighten the lock screw. Start the engine. After the fuel level has stabilized, stop the engine and check the level at the sight plug opening. The fuel level should be below specified limits. If it is not, repeat step 3, turning the adjusting nut an additional amount sufficient to lower the fuel below the specified level.

5. Loosen the lock screw and turn the adjusting nut out in increments of 1/6 turn or less until the correct fuel level is achieved. After each adjustment, tighten the lock screw, and then start the engine and stabilize the fuel level. Check the fuel level



**FIG. 10—Fuel Level Adjustment**

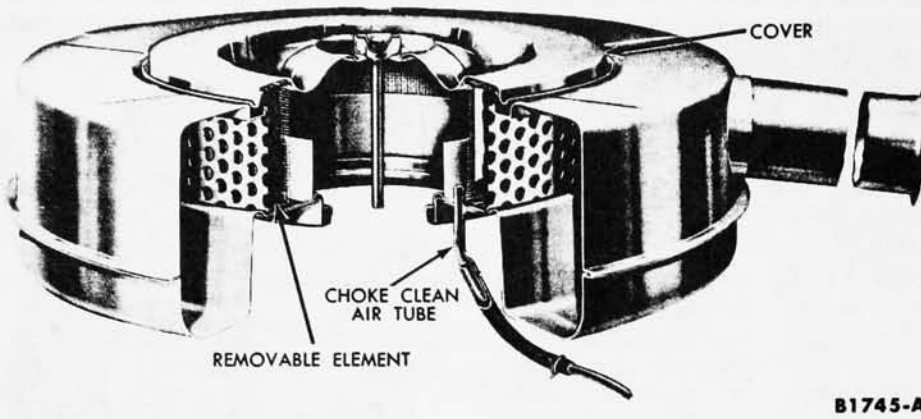
**Accelerating Pump Adjustment.**

**100% SATISFACTION GUARANTEED**

**BUY IT NOW!**

**Click Here To Order**

PayPal, American Express, Discover, MasterCard, VISA



**FIG. 11—Air Cleaner Assembly**

at the sight plug opening. Install the sight plug and gasket.

6. Install the air cleaner. Check and adjust the idle fuel mixture and idle speed as necessary.

**AIR CLEANER (Part 3-1)**

The engine is equipped with a dry-type air cleaner that has a replaceable cellulose fiber filtering element (Fig. 11). The air from the engine compartment enters the air cleaner through the opening on the side and passes through the filter element. The filtered air is deflected down into the carburetor. Dust particles are trapped in the filter element as the air rushes through it. A tube attached to the filtered air chamber is connected to the automatic choke heat chamber in the right exhaust manifold to supply clean air to the automatic choke.

**MAINTENANCE**

Refer to Group 12 for the recom-

mended maintenance mileage interval for cleaning and replacement of air cleaner elements.

**REMOVAL**

1. Remove the air cleaner wing nut. Disconnect the choke clean air tube, and lift the air cleaner off the carburetor.

2. Remove the cover and lift the element out of the air cleaner body.

**INSTALLATION**

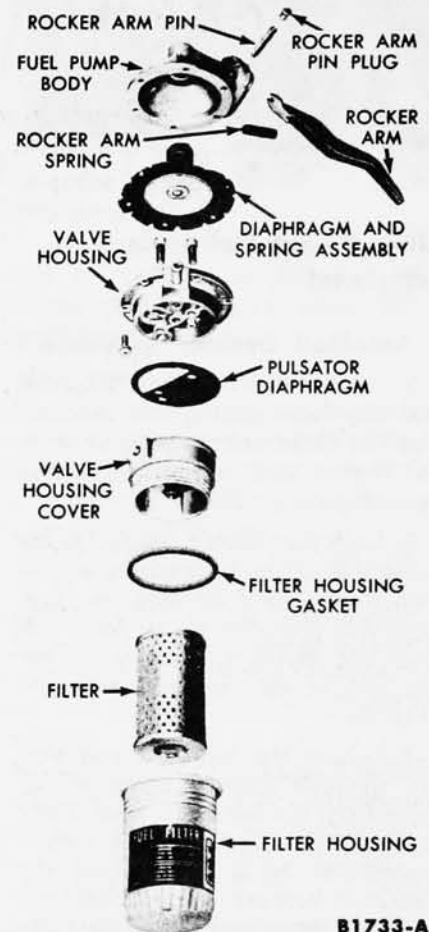
1. Place the air cleaner body on the carburetor so that the word "FRONT" faces the front of the car. Connect the choke clean air tube to the air cleaner.

2. Place the element in the air cleaner body. Install the cover.

**FUEL PUMP (Part 3-3)**

The 1963 Carter design fuel pump is basically the same as the 1962

pump except for incorporation of a horizontal cross vent system in place of the vertical passage, increased diameter internal fuel passages, and pressure leak-down bleeds in the pump valves. In addition, the pump will incorporate the long-life, disposable fuel filter element (Fig. 12).



**FIG. 12—Fuel Pump Assembly**

**GROUP 4—COOLING SYSTEM**

The 1963 maintenance recommendations are in Group 12 and the 1963 specifications are in Group 13 of this manual.

All the service procedures outlined in Group 4 of the 1962 Shop Manual remain the same with the following exceptions.

**THERMOSTAT TEST**

Remove the thermostat and immerse it in boiling water. Replace the thermostat if it does not open more than 1/4 inch. If the problem being investigated is insufficient heat, the thermostat should be checked for leakage. This may be done by holding the thermostat up to a lighted background. Light leakage around the thermostat valve (thermostat at room temperature) is unacceptable and the thermostat should be replaced. It is possible, on some thermostats, that a slight leakage of light at one or two

locations on the perimeter of the valve may be detected. This should be considered normal.

**FAN BELTS**

**REMOVAL**

1. Loosen the power steering pump bracket at the water pump and remove the drive belt.

On a car with an air conditioner, remove the compressor drive belt.

2. Loosen the alternator mounting bolts and the alternator adjusting arm

OSTAT

**100% SATISFACTION GUARANTEED**

**BUY IT NOW!**

**Click Here To Order**

bolt. Move the alternator toward the engine. Remove the belts from the alternator and crankshaft pulleys, and lift them over the fan.

**INSTALLATION**

1. Place the belts over the fan. In-

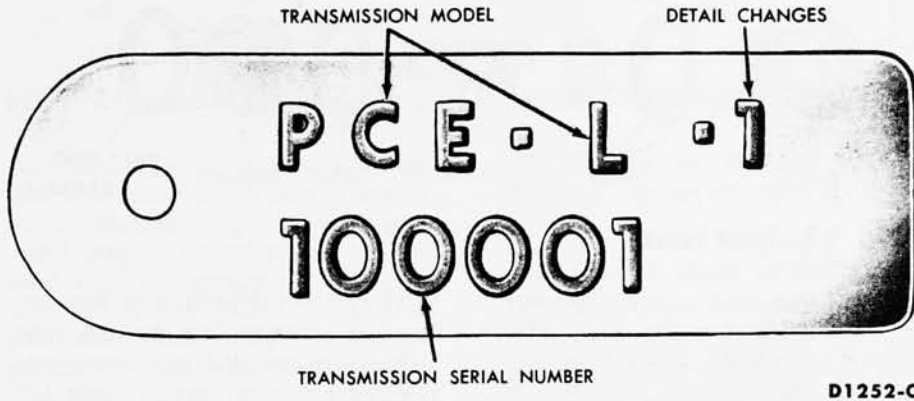
sert the belts in the water pump pulley, crankshaft pulley, and alternator pulley grooves. Adjust the belt tension to specifications.

2. On a car with an air conditioner, install and adjust the com-

pressor drive belt to specifications.

3. Install the power steering pump drive belt and tighten the pump bracket to the water pump. Adjust the drive belt tension to specifications.

**GROUP 5—CRUISE-O-MATIC TRANSMISSION**



**FIG. 13—Cruise-O-Matic Identification Tag**

The 1963 maintenance recommendations are in Group 12 and the 1963 specifications are in Group 13 of this manual.

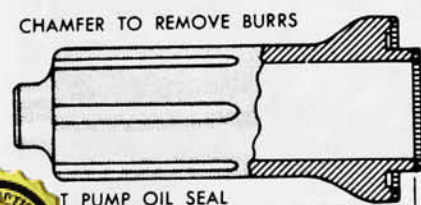
All of the procedures outlined in Group 5 of the 1962 Shop Manual remain the same with the following exceptions.

**IDENTIFICATION TAG (Part 5-1)**

The transmission identification tag (Fig. 13) is attached to the left side of the case. The first line on the tag indicates the model. The second line indicates the Serial No. and starts with 100001.

**FRONT OIL PUMP SEAL (Part 5-5)**

A new improved pump seal is being used in the 1963 models. The



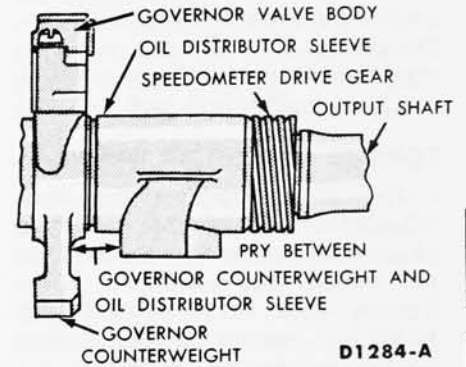
new seal is 1/8-inch narrower than the seal previously used. The seal is removed and installed in the same manner as the old type except for the tool. The existing tool (T59L-77837-A) can be reworked as shown in Fig. 14 to install the narrower seal or a new tool (T63L-77837-A) is available.

**NYLON-TYPE SPEEDOMETER DRIVE GEAR (Part 5-5)**

A nylon speedometer drive gear replaces the steel drive gear previously used. If gear replacement is necessary, the old type steel gear may be used.

The nylon drive gear is a 0.004-0.010-inch shrink fit on the output shaft and can be removed or installed in the following manner.

1. Remove the output shaft from the transmission in the usual manner.
2. Remove the oil distributor tubes from the sleeve.
3. Remove the speedometer drive gear snap ring from the shaft.
4. Pry the oil delivery sleeve toward the rear of shaft with a hammer handle. Make certain to apply pressure on the governor counterweight, and not against the governor valve body (Fig. 15).



**FIG. 15—Pressure Apply Point for Drive Gear Removal**

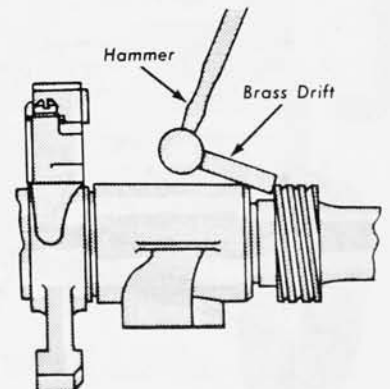
5. Slide the oil delivery sleeve toward the front of the transmission.

6. Using a hammer and a small brass drift, tap the gear evenly and alternately (Fig. 16) to prevent cocking it on the shaft. Tap the gear gently to prevent damaging it.

7. To install the gear, dip it in transmission fluid and place it on an illuminated 100-watt light bulb.

8. Allow the gear to remain on the bulb for five minutes, then, turn it over and heat the other side for five minutes. This will heat the gear to approximately 180°F.

9. Make sure the lock ball is in



**FIG. 16—Speedometer Drive Gear Removal**

100% SATISFACTION GUARANTEED

**BUY IT NOW!**

Click Here To Order

PayPal, American Express, Discover, MasterCard, VISA

place on the shaft, then quickly slide the gear into place.

10. Install the speedometer drive gear snap ring on the output shaft.

11. Install the output shaft in the usual manner.

**OUTPUT SHAFT THRUST WASHER (Part 5-5)**

A new type needle bearing thrust washer is used in the 1963 Thunderbird transmission. A counterbore is provided in the rear pump to accommodate the thrust bearing race. Figure 17 shows the relative position of the thrust washer and race.

**TORQUE CONVERTER (Part 5-6)**

The 1963 converter has been modified to replace the sprag-type clutch with a roller-type clutch. Also, the bronze and aluminum thrust washers have been replaced with aluminum coated stamped thrust washers and flat steel retainers.

The design of the new thrust washers is such that a new longer locking rod (Tool T63P-7902-A) will be required for use with the existing converter clutch checking tool.

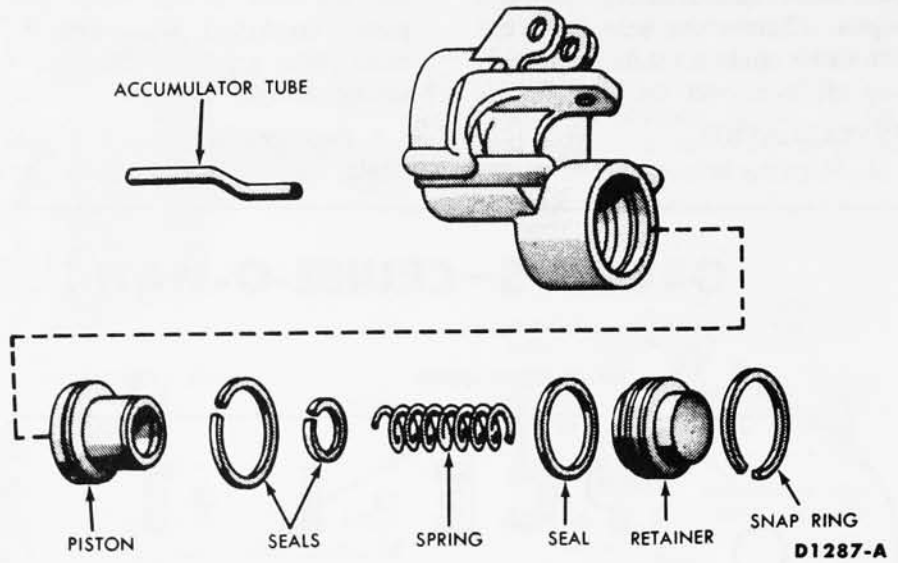
The checking procedure is the same as for previous model converters.

**FRONT SERVO (Part 5-5)**

The accumulator piston and related parts have been eliminated on the 1963 models. Servicing of the servo remains the same as in the 1962 manual with the exception of the eliminated parts shown in Figure 18.

**CONVERTER HOUSING (Part 5-4)**

To accommodate the addition of



**FIG. 18—Front Servo**

an 0.075-inch thick engine rear cover plate mounted between the transmission and engine, a new converter housing and converter assembly is used. The new converter housing will have the starter pilot eliminated. Piloting of the starter will be accomplished by the engine rear cover plate.

The new converter assembly will have longer flywheel mounting stud pads and a longer crankshaft pilot, in order to provide adequate piloting in the crankshaft and maintain the same converter to front pump relationship.

**PARKING LINKAGE (Part 5-5)**

Figure 19 illustrates the new type parking pawl linkage in the transmission. The control rod incorporates a compression spring to drive the toggle lift lever into the apply position.

The following parts have been revised to accommodate the new type linkage; manual shaft and lever, control valve detent lever, toggle lift lever, torsion rod and the lift lever shaft.

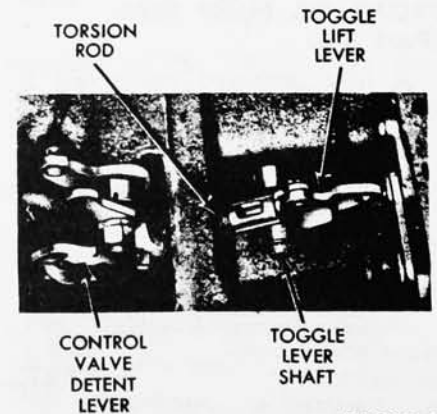
**PLANETARY CLUTCH (Part 5-5)**

A new roller-type planetary clutch has replaced the sprag-type clutch previously used. The new roller-type clutch requires a new planet carrier with a cam-type clutch race (Fig. 20). In conjunction with the clutch and the planet carrier, a new type center support is used.

The roller clutch is installed in the same location, and functions in the same manner as the sprag-type clutch previously used. The original center support is chamfered at the rear of



D1289-A



D1290-A

**FIG. 19—Parking Linkage Installed**

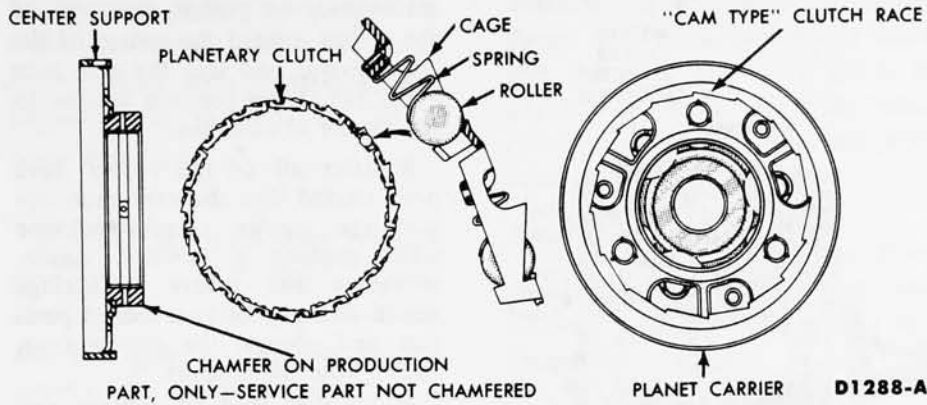


FIG. 20—Planetary Clutch, Planet Carrier and Center Support

the clutch race to accommodate the new type roller clutch only. The new service planetary support is not provided with a chamfer and can be used with the sprag-type clutch as well as the new roller clutch. The new chamfered planetary support cannot be used with the sprag-type clutch because the chamfer could reduce sprag contact area on the inner race, resulting in loss of capacity and cause premature clutch wear. The method of installing the roller-type clutch on the center support with a chamfered edge is different from a support with a square edge as detailed in the following procedure.

**INSTALLATION—Center Support with Chamfered Edge**

1. Install the center support and the rear band in the case.
2. Install the primary sun gear rear thrust bearing race and the bearing in the planet carrier using petroleum jelly to retain them in place.
3. Lubricate the bearing surface on the center support, the rollers of the planetary clutch and the cam race in the carrier with petroleum jelly.
4. Install the planetary clutch in the carrier (Fig. 21).
5. Carefully position the planet carrier on the center support. Move the carrier forward until the clutch rollers are felt to contact the bearing surface of the center support.

will ride up the chamfer on the planetary support and onto the inner race.

7. Push the planet carrier all the way forward.
8. Check the operation of the planetary clutch by rotating the carrier counterclockwise. It should rotate with a slight drag while rotating it counterclockwise (viewed from the rear) and it should lock up when attempting to rotate it in a clockwise direction.

**INSTALLATION—Center Support with Square Edge**

1. Install the center support and the rear band in the case.

2. Install the primary sun gear rear thrust bearing race and the bearing in the planet carrier using petroleum jelly to retain them in place.

3. Lubricate the bearing surface on the center support, the rollers of the planetary clutch and the cam race in the carrier with petroleum jelly.

4. Install the planetary clutch on the center support with the "saw-teeth" of the clutch cage pointing in the clockwise direction as viewed from the rear (Fig. 22). Make sure that all rollers are in the cage.

5. Position the planet carrier on the support so that the cams in the carrier engage the "saw-teeth" on the clutch cage.

6. Push the planet carrier forward until the rollers are felt to contact the surface of cam race.

7. While applying forward pressure on the carrier, rotate it counterclockwise as viewed from the rear. This will cause the rollers to roll toward the large opening end of the cams in the race, compressing the springs slightly, so that the roller will enter the cams.

8. Some rollers may become cocked preventing their entry into the outer race. These rollers must be

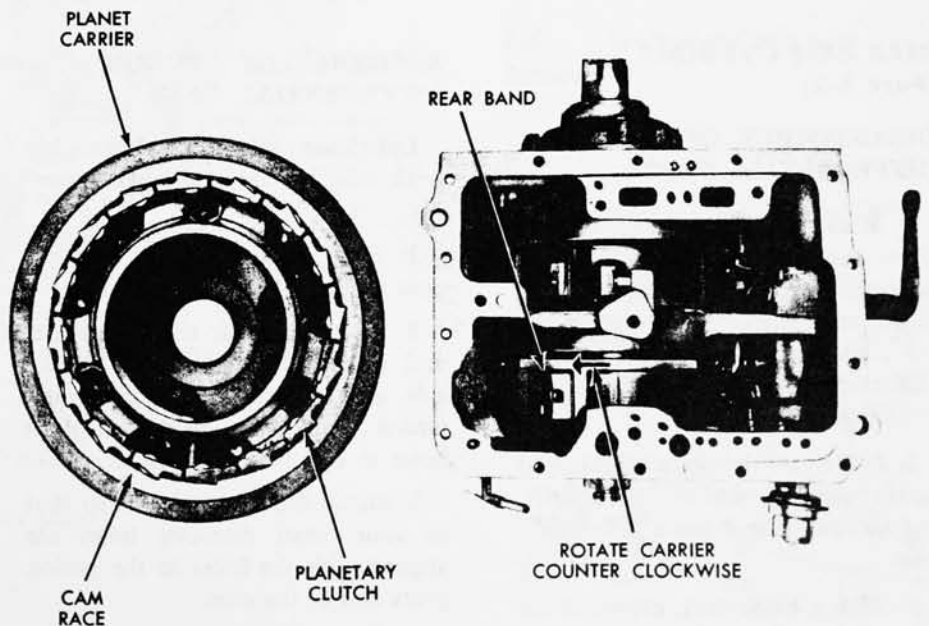


FIG. 21—Planetary Clutch Installed in Carrier

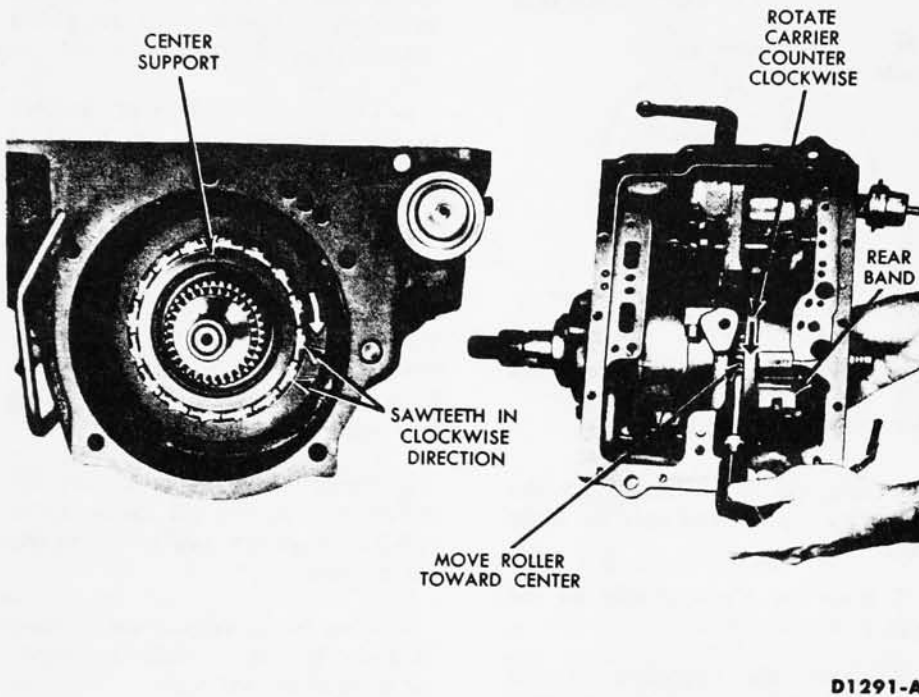
While applying forward pressure

**100% SATISFACTION GUARANTEED**

**BUY IT NOW!**

**Click Here To Order**

PayPal, American Express, Discover, MasterCard, VISA



D1291-A

FIG. 22—Planetary Clutch Installed on Center Support

positioned individually with a small screwdriver by pushing the rear of the rollers toward the center of the transmission and into the cam race (Fig. 22). Keep pressure applied to the carrier at all times.

9. After all of the rollers have been started into the cam race, rotate the carrier counterclockwise while pushing it forward. Again, straighten any rollers or springs which still may be in a cocked position and prevent the carrier from sliding onto the support.

Make sure that all springs are entered into the cam race before pushing the carrier onto the roller clutch.

10. Push the carrier all the way forward and check the operation of the clutch by rotating it in a counterclockwise direction. The carrier should rotate counterclockwise with a slight drag and should lock up when attempting to rotate it in a clockwise direction.

## GROUP 6—REAR AXLE AND DRIVE LINE

The 1963 maintenance recommendations are in Group 12 and the 1963 specifications are in Group 13 of this manual.

All the service procedures outlined in Group 6 of the 1962 Shop Manual apply to the 1963 Thunderbird with the following exceptions.

### REAR AXLE OVERHAUL (Part 6-2)

#### DISASSEMBLY OF 4-PINION DIFFERENTIAL CASE

1. Remove the differential case from the carrier and remove the bearings and drive gear from the case as outlined in steps 1 through 4 under "Disassembly of Conventional Differential Carrier," page 6-8 of the 1962 manual.

2. Drive out the three differential pinion shaft retainers with a drift, separate the 2-piece differential

4. Remove the two short pinion shafts. Using a drift, drive each shaft from the center outward.

5. Lift out the center block, then remove the gears and thrust washers.

6. To disassemble the remaining carrier parts, follow steps 7 through 13 on page 6-9 of the 1962 manual.

#### ASSEMBLY OF 4-PINION DIFFERENTIAL CASE

Lubricate all parts thoroughly with axle lubricant during assembly.

1. Place a thrust washer and side gear in the differential case bore.

2. Install the four thrust washers, and place the pinion gears on the side gear. Align the washers and pinion gears with the pinion shaft holes in the case (Fig. 23).

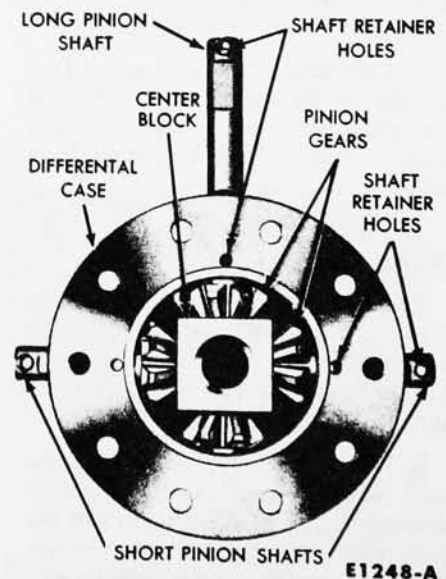
3. Install the center block so that its four small diameter holes are aligned with the holes in the pinion gears and in the case.

4. With a brass drift, drive in the two short pinion shafts from the outside of the case (Fig. 23). Be sure

to align the shaft retainer holes as each shaft is being driven into place.

5. Drive the long pinion shaft into place from the retainer hole end of the case being sure to align the retainer hole in the shaft with that in the case.

6. Place the second side gear and



E1248-A

FIG. 23—Four-Pinion Differential

**100% SATISFACTION GUARANTEED**

**BUY IT NOW!**

**Click Here To Order**

PayPal, American Express, Discover, MasterCard, VISA

thrust washer on top of the four pinion gears, then install the differential case cover so that the three shaft retainer holes in the cover are aligned with their corresponding holes in the case.

7. Install the three shaft retainer pins with a drift. A pinion or axle shaft spline can be inserted in the side gear spline to check for free rotation of the differential gears.

8. Fill differential case with axle lubricant.

9. Insert two 7/16 (N.F.) bolts 2-inches long through the differential flange, and thread them 3 or 4 turns into the drive gear as a guide in aligning the drive gear bolt holes. Press or tap the drive gear into position.

10. Install and tighten the drive gear bolts and washers evenly, and torque them alternately across the gear to specifications.

11. If the differential bearings have been removed, press them on as shown in Fig. 24.

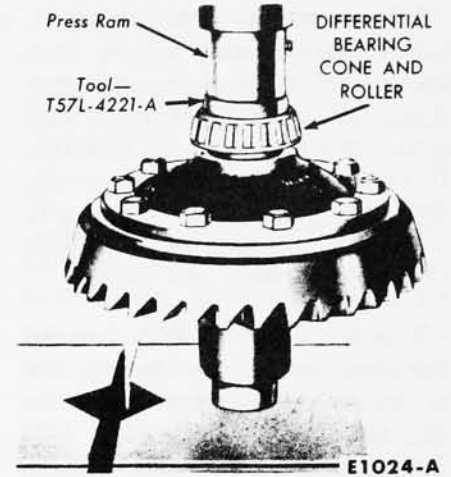


FIG. 24—Differential Bearing Installation

## GROUP 7—STEERING

The 1963 maintenance recommendations are in Group 12 and the 1963 specifications are in Group 13 of this manual.

All the service procedures outlined in Group 7 of the 1962 Shop Manual apply to the 1963 Thunderbird with the following exceptions.

### REPAIR (Part 7-2)

#### STEERING GEAR REMOVAL AND INSTALLATION

1. Disconnect the pressure line and

the return line from the steering gear housing. Plug the openings and cap the lines.

2. Remove the bolt that locks the flex joint clamp to the steering gear worm shaft (Fig. 25).

3. Raise the car and disconnect the sector shaft (pitman) arm from the sector shaft, using the tool shown in Fig. 26.

4. Remove the steering gear mounting bolts (Fig. 27), and pull the steering gear assembly out of the flex joint.



FIG. 26—Sector Shaft Arm Removal

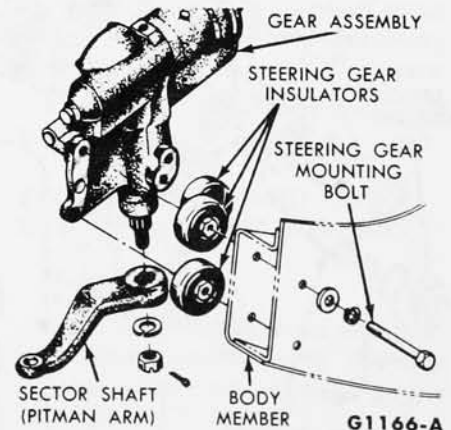
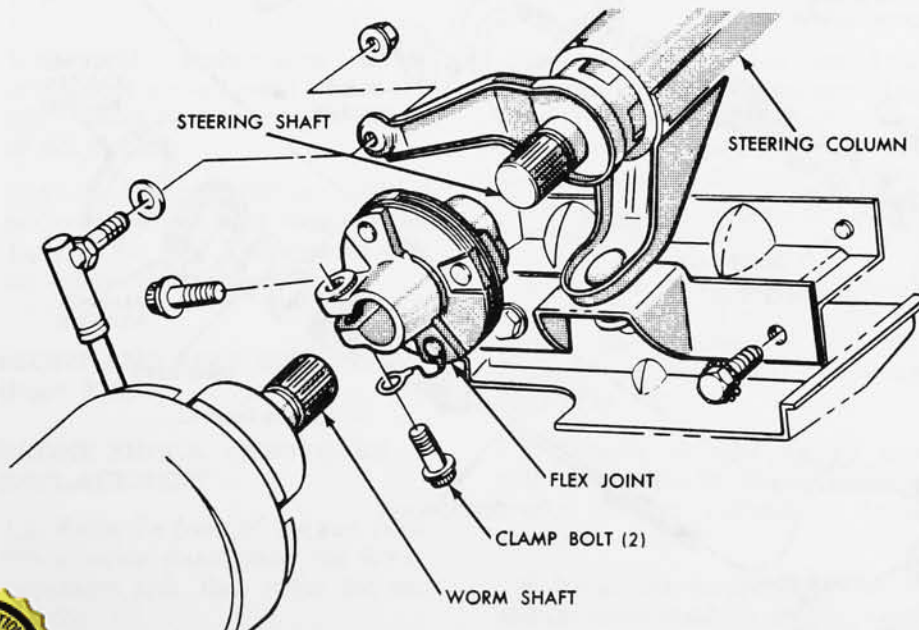


FIG. 27—Steering Gear Mountings

**100% SATISFACTION GUARANTEED**

**BUY IT NOW!**

**Click Here To Order**

PayPal, American Express, Discover, MasterCard, VISA

Part-to-Steering Gear Connections

G1165-A

G1166-A

# 1962 FORD

# *Thunderbird*



# SHOP MANUAL



**BUY IT NOW!**

**Click Here To Order**



PayPal

Discover  
Cards

DISCOVER  
NOWUS

MasterCard

VISA



Copyright © 2009, Forel Publishing Company, LLC, Woodbridge, Virginia

All Rights Reserved. No part of this book may be used or reproduced in any manner whatsoever without written permission of Forel Publishing Company, LLC. For information write to Forel Publishing Company, LLC, 3999 Peregrine Ridge Ct., Woodbridge, VA 22192

## **1962 Ford Thunderbird Shop Manual**

**EAN: 978-1-60371-012-1**

**ISBN: 1-60371-012-4**

Forel Publishing Company, LLC

3999 Peregrine Ridge Ct.

Woodbridge, VA 22192

Email address: [webmaster@ForelPublishing.com](mailto:webmaster@ForelPublishing.com)

Website: <http://www.ForelPublishing.com>



This publication contains material that is reproduced and distributed under a license from Ford Motor Company. No further reproduction or distribution of the Ford Motor Company material is allowed without the express written permission of Ford Motor Company.

---

## **Note from the Editor**

This product was created from the original Ford Motor Company's publication. Every effort has been made to use the original scanned images, however, due to the condition of the material; some pages have been modified to remove imperfections.

---

## **Disclaimer**

Although every effort was made to ensure the accuracy of this book, no representations or warranties of any kind are made concerning the accuracy, completeness or suitability of the information, either expressed or implied. As a result, the information contained within this book should be used as general information only. The author and Forel Publishing Company, LLC shall have neither liability nor responsibility to any person or entity with respect to any loss or damage caused, or alleged to be caused, directly or indirectly by the information contained in this book. Further, the publisher and author are not engaged in rendering legal or other professional services. If legal, mechanical, electrical, or other expert assistance is required, the professional should be sought.



# 1962

# FORD THUNDERBIRD

# SHOP MANUAL

## INDEX

GROUP

THUNDERBIRD IDENTIFICATION

ENGINE AND EXHAUST SYSTEM

1

IGNITION SYSTEM

2

FUEL SYSTEM

3

COOLING SYSTEM

4

CRUISE-O-MATIC TRANSMISSION

5

REAR AXLE AND DRIVE LINE

6

STEERING

7

BRAKES AND SUSPENSION

8

GENERATING AND STARTING  
SYSTEMS

9

LIGHTS, INSTRUMENTS, AND  
ACCESSORIES

10

BODY

11

MAINTENANCE, LUBRICATION,  
AND SPECIAL TOOLS

12

INDEX

SPECIFICATIONS AT THE END OF EACH GROUP

SERVICE DEPARTMENT  
FORD DIVISION  
COMPANY

**BUY IT NOW!**

Click Here To Order



PayPal

Discover  
Cards

Discover  
Novus

MasterCard

VISA

Reprinted under license from Ford Motor Company January 2006

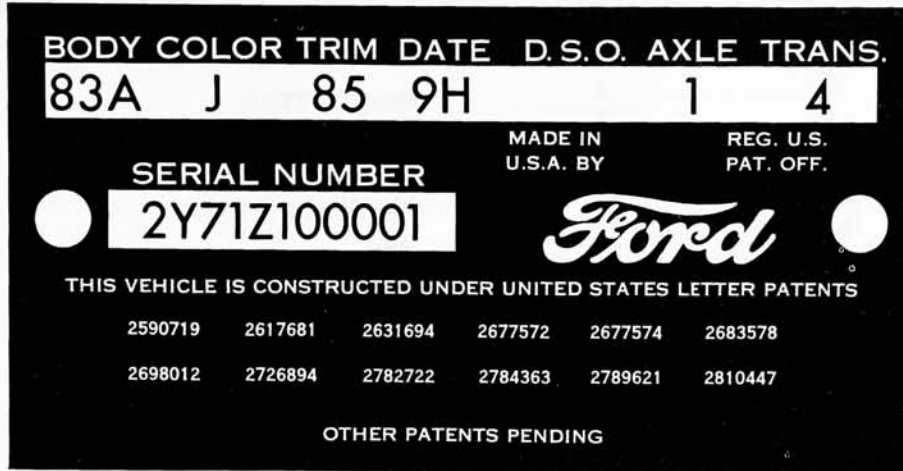
## FOREWORD

*This manual provides information for the proper servicing of the 1962 Thunderbird. The descriptions and specifications contained in this manual were in effect at the time the manual was approved for printing. The Ford Division of Ford Motor Company reserves the right to discontinue models at any time, or change specifications or design, without notice and without incurring obligation.*

**SERVICE DEPARTMENT  
FORD DIVISION  
FORD MOTOR COMPANY**



# THUNDERBIRD IDENTIFICATION



M1072-A

FIG. 1—Thunderbird Patent Plate

Fig. 1 illustrates a Thunderbird patent plate and its elements. The patent plate is attached to the left door front pillar.

## VEHICLE DATA

Example (Fig. 1):

63A	J	85	9H	1	4
63A	Tudor Hardtop				
J	Red				
85	Red Leather				
9H	Ninth day of August				
1	3.00:1 Axle Ratio				
4	Cruise-O-Matic				

## BODY

63A	Tudor Hardtop
76A	Tudor Convertible

## COLOR

If a special paint is used, the paint color space will not be stamped.

Code	M30J Number	Color	Sales Name
A	1724	Black	Raven Black
D	1070	Med. Turquoise Metallic	Patrician Green
E	1269	Med. Blue Metallic	Acapulco Blue
F	1226	Lt. Blue	Skymist Blue
G	1446	Silver Blue Metallic	Silver Mink
H	1544	Dark Blue Metallic	Caspian Blue
J	1515	Red	Rangoon Red
K	1452	Lt. Turquoise	Chalfonte Blue
L	1458	Pink	Sahara Rose
M	1238	White	Corinthian White
	921	Diamond Blue	Diamond Blue
	1456	Yellow	Tucson Yellow
			Sandshell Beige
			Deep Sea Blue
			Chestnut
			Heritage Burgundy
			Fieldstone Tan

## TRIM

Deviation trim sets will use existing trim codes plus a suffix. A trim code with a numerical suffix is not serviced, while a trim code with an alphabetical suffix is serviced.

Code	Color and Material
50	Lt. Silver Blue Met. Vinyl
52	Light Blue Metallic Vinyl
54	Lt. Pearl Beige Vinyl
55	Red Vinyl
56	Black Vinyl
57	Light Turquoise Metallic Vinyl
59	Med. Chestnut Vinyl
70	Lt. Silver Blue Met. Vinyl & Med. Silver Blue Bedford Cloth
72	Lt. Blue Met. Vinyl & Med. Blue Bedford Cloth
74	Lt. Pearl Beige Vinyl & Med. Beige Bedford Cloth
76	Black Vinyl & Med. Gray Bedford Cloth
77	Lt. Turquoise Met. Vinyl & Med. Turquoise Bedford Cloth
80	Lt. Silver Blue Met. Leather
82	Med. Blue Leather
84	Lt. Pearlescent Beige Leather
85	Red Leather
86	Black Leather
87	Lt. Turquoise Metallic Leather
89	Med. Chestnut Metallic Leather



**BUY IT NOW!**

Click Here To Order



## DATE

The code letters for the month are preceded by a numeral to show the day of the month when the Thunderbird was completed. The second year code letters are to be used if 1962 model production exceeds 12 months.

Month	First Model Year	Second Model Year
January	A	N
February	B	P
March	C	Q
April	D	R
May	E	S
June	F	T
July	G	U
August	H	V
September	J	W
October	K	X
November	L	Y
December	M	Z

## DSO

Thunderbirds built to a Domestic Special Order, Foreign Special Order, or Pre-Approved Order have the complete order number recorded in this space. If the unit is regular production, this space will remain blank.

## AXLE

Code	Ratio
1	3.00:1
A*	3.00:1

\*Equa-Lock type.

## TRANSMISSION

Code	Type
4	Cruise-O-Matic

## SERIAL NUMBER

Example (Fig. 1): 2Y83Z100001

2	1962 Model
Y	Wixom Assembly Plant
83	Tudor Hardtop
Z	8-Cylinder 390 Cubic Inch Engine
100001	First Unit Built

## MODEL YEAR

The number "2" designates 1962.

## ASSEMBLY PLANT

Code	Location
Y	Wixom Assembly Plant
S	Pilot Plant

## MODEL

Code	Type
83	Tudor Hardtop
85	Tudor Convertible

## ENGINE

Code	Type
R	8-Cylinder 390 Cubic Inch (4-barrel Low Compression Export, 84 Octane)
Z	8-Cylinder 390 Cubic Inch (4-barrel)

## CONSECUTIVE UNIT NUMBER

The assembly plant, with each model year, begins with consecutive unit number 100001 and continues on for each unit built.

**SATISFACTION 100% GUARANTEED**

**BUY IT NOW!**

**Click Here To Order**

PayPal American Express Discover MasterCard VISA

# 1962 FORD THUNDERBIRD SHOP MANUAL

## GROUP I

# ENGINE AND EXHAUST SYSTEM

	PAGE
<b>PART 1-1</b> ENGINE .....	1- 2
<b>PART 1-2</b> EXHAUST SYSTEM .....	1-41
<b>PART 1-3</b> SPECIFICATIONS .....	1-43



**BUY IT NOW!**

**Click Here To Order**



# PART

## 1-1

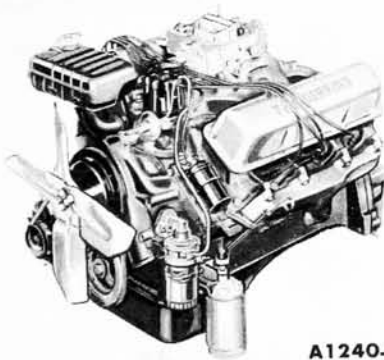
# ENGINE

Section	Page
5 In-Chassis Repair	
Operations (Continued)	
Camshaft Rear Bearing Bore Plug Replacement . . .	1-26
Hydraulic Valve Lifter Replacement . . . . .	1-26
Crankshaft Lower Rear Oil Seal Replacement . . .	1-27
Main and Connecting Rod Bearing Replacement	1-28
Piston and Connecting Rod Assembly . . . . .	1-28
Flywheel . . . . .	1-32
Oil Filter Replacement . . .	1-32
Oil Pan and Oil Pump . . .	1-32
6 Work Stand Repair	
Operations . . . . .	1-34
Crankshaft . . . . .	1-34
Camshaft Bearing Replacement . . . . .	1-36
Engine Disassembly . . . .	1-36
Cylinder Block . . . . .	1-38
Engine Assembly . . . . .	1-38
7 Crankcase Ventilation System Maintenance . . . . .	1-40

Section	Page
1 Description . . . . .	1-2
2 Engine Trouble Diagnosis . .	1-6
3 Engine Tests and Adjustments . . . . .	1-12
4 Engine Removal and Installation . . . . .	1-13
5 In-Chassis Repair	
Operations . . . . .	1-15
Engine Supports . . . . .	1-15
Valve Rocker Arm Shaft Assembly . . . . .	1-15

Section	Page
5 In-Chassis Repair	
Operations (Continued)	
Intake Manifold . . . . .	1-17
Exhaust Manifold . . . . .	1-18
Positive Crankcase Ventilation System . . . . .	1-19
Cylinder Heads and Valves . . . . .	1-19
Valve Stem Seal Replacement . . . . .	1-22
Cylinder Front Cover and Timing Chain . . . . .	1-23
Camshaft . . . . .	1-25

## 1 DESCRIPTION

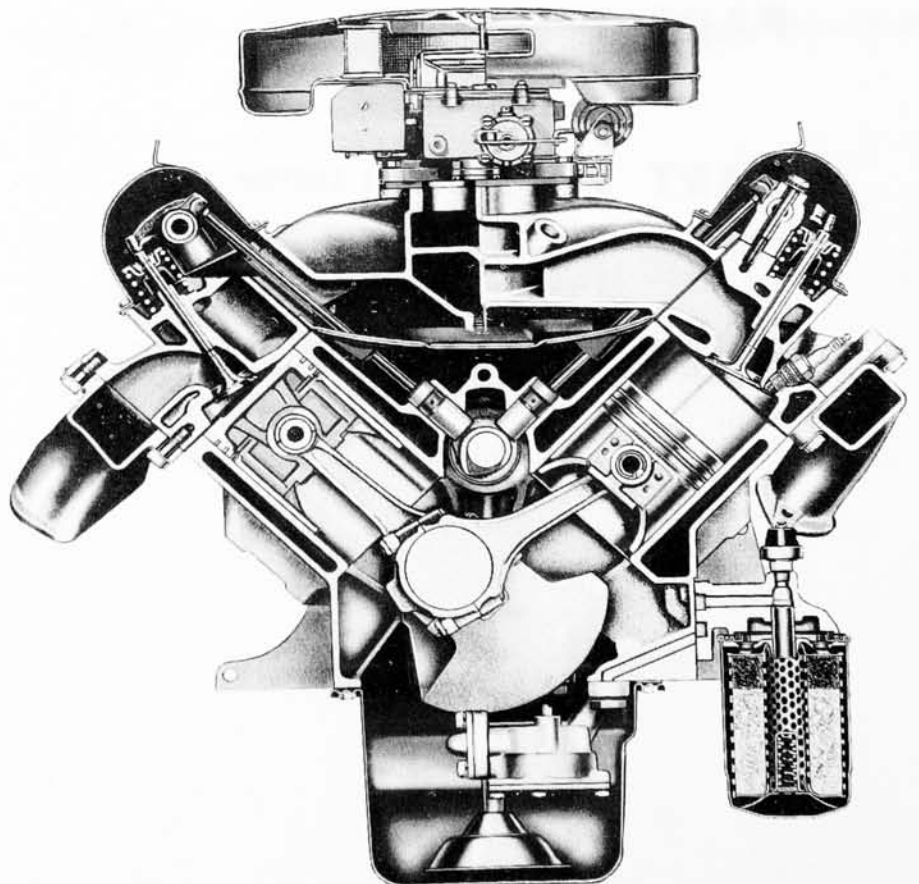


**FIG. 1—Thunderbird 390 Special V-8 Engine**

The Thunderbird 390 Special V-8 engine (Figs. 1 and 2) has a 4.05-inch bore and a 3.78-inch stroke and a total piston displacement of 390 cubic inches. It has a compression ratio of 9.6:1. The patent plate symbol for the engine is "Z."

### MANIFOLDS

An engine coolant heated spacer is located between the carburetor and the intake manifold (Fig. 3).

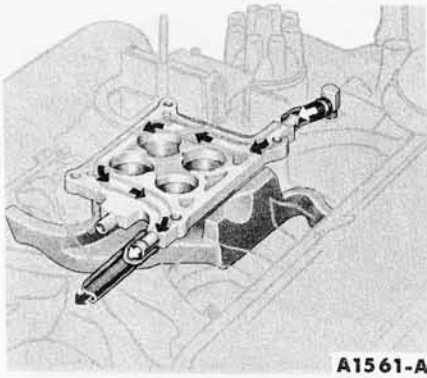


**FIG. 2—Sectional View 390 Special V-8 Engine**

SATISFACTION 100% GUARANTEED

BUY IT NOW!

Click Here To Order



**FIG. 3—Intake Manifold Coolant Passages**

haust gases provide the initial heat necessary to assist in vaporizing the incoming fuel mixture.

The intake manifold has two sets of fuel passages, each with its own separate inlet connection to the carburetor (Fig. 4). The right barrels of the carburetor feed Nos. 1, 4, 6, and 7 cylinders and the left barrels feed Nos. 2, 3, 5, and 8 cylinders.

The distributor is mounted at the left front of the intake manifold.

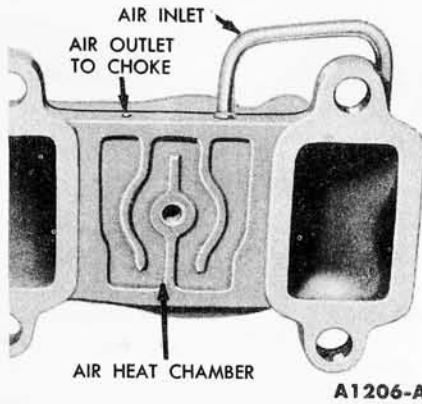
Warm air for the automatic choke is drawn from the heat chamber of the right exhaust manifold (Fig. 5).

**CYLINDER HEADS**

The cylinder head assemblies contain the valves and the valve rocker arm shaft assembly. The combustion chambers are machined in the head. Valve guides are an integral part of the head. The valves are arranged from front to rear on both banks E-I-E-I-E-I-E (Fig. 6).

**CYLINDER BLOCK**

The cylinders are numbered from front to rear, on the right bank 1, 2,



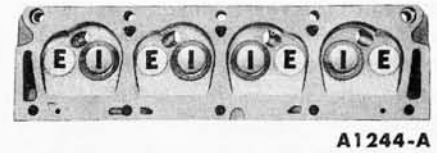
**FIG. 5—Automatic Choke Heat Chamber**

3 and 4 and on the left bank 5, 6, 7 and 8. The firing order is 1-5-4-2-6-3-7-8.

The oil pump, mounted inside the oil pan at the front, is driven by the distributor through an intermediate drive shaft.

The crankshaft is supported by five main bearings. Crankshaft end thrust is controlled by the flanges of the No. 3 main bearing.

The pistons have two compression rings and one oil control ring. The top compression ring is chrome-plated and the lower compression ring is phosphate-coated. The oil control ring assembly consists of a serrated spring and two chrome-plated steel rails.



**FIG. 6—Valve Port Arrangement**

**VALVE TRAIN**

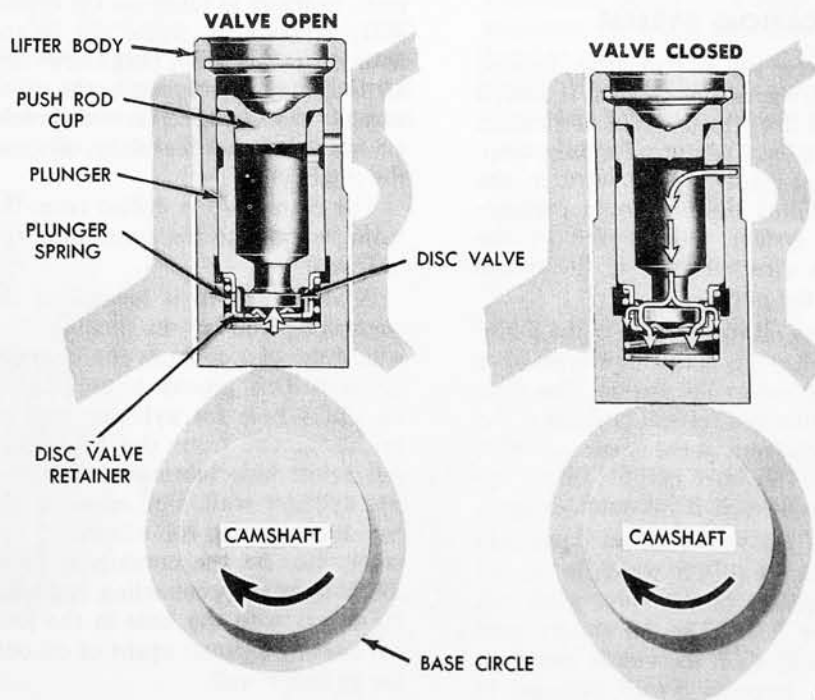
The intake and exhaust valve assemblies are the rotating-type which rotate each time the valve opens and closes.

The push rods are solid steel with oil cushioned sockets.

The camshaft is supported by five bearings pressed into the block. It is driven by a sprocket and timing chain in mesh with a sprocket on the crankshaft. Camshaft end play is controlled by a thrust button and spring located between the camshaft sprocket bolt and the cylinder front cover. An eccentric, bolted to the front end of the camshaft, operates the fuel pump.

Hydraulic valve lifters are used which provide zero valve lash. The operation and parts identification of the hydraulic valve lifters are shown in Fig. 7.

When the valve is closed, the lifter assembly is on the base circle of the camshaft lobe and the valve push rod is in its lowest position. With the lifter assembly in this position, the plunger spring expands forcing the plunger upward. This action is trans-



**FIG. 7—Typical Hydraulic Valve Lifter Operation**

A1245-A

**FRONT**

**100% SATISFACTION GUARANTEED**

**BUY IT NOW!**

**Click Here To Order**

mitted to the valve rocker arm via the valve push rod until there is solid contact between the valve and the valve end of the valve rocker arm (zero valve lash). In this position, the oil hole in the lifter and plunger is indexed with the lifter oil gallery and oil is forced under pressure into the plunger. This creates a pressure differential above and below the valve disc. The high pressure above the valve disc forces the valve disc open and the oil fills the area below the plunger, equalizing the pressure on each side of the valve disc.

Whenever clearance between the valve and the valve rocker arm tends to be present, the plunger spring expands pushing the plunger until there is solid contact between all parts of the valve train mechanism.

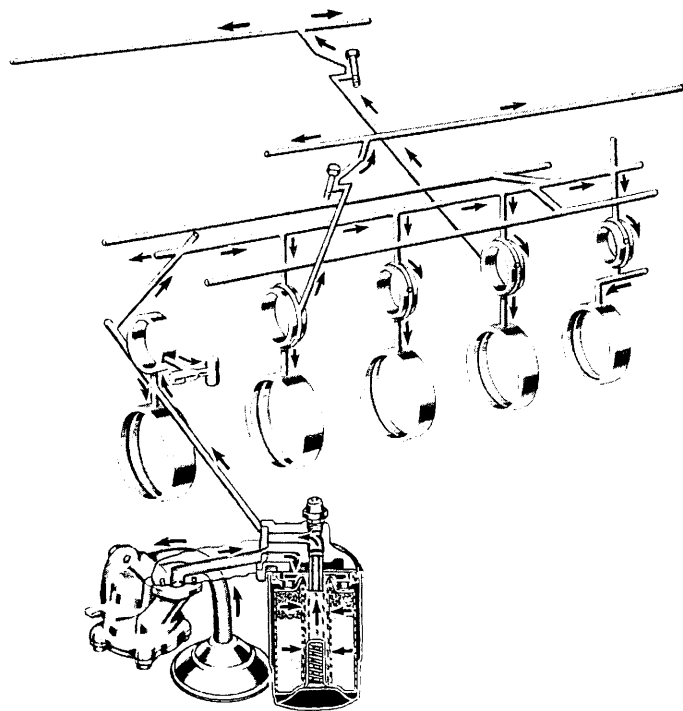
As the camshaft rotates (valve opening), the valve lifter is raised and the sudden increase in oil pressure below the plunger forces the valve disc closed and the lifter becomes a hydraulic ram. During this period, a slight leakage of oil from below the plunger occurs. As the high point on the camshaft lobe rotates past the lifter, the push rod forces the valve lifter down and re-seats the valve. The pressure on the oil below the plunger is relieved and the valve disc opens so that the chamber can again be filled. This cycle is repeated for each revolution of the camshaft.

## LUBRICATION SYSTEM

Oil from the oil pan sump, located in the front of the oil pan, is forced through the pressure-type lubrication system (Fig. 8) by a rotor oil pump. A spring-loaded relief valve in the pump limits the maximum pressure of the system. Oil relieved by the valve is directed back to the intake side of the pump.

All the oil discharged by the pump passes through a full flow-type filter before it enters the engine. The filter is mounted in a vertical position at the lower left front of the engine. A relief valve in the filter permits oil to bypass the filter if it becomes clogged.

From the filter, the oil flows into the main oil gallery which is located



A1246-A

**FIG. 8—Lubrication System**

bearing. No. 1 camshaft bearing feeds No. 1 main bearing, and No. 2 camshaft bearing feeds No. 2 main bearing, etc. The oil then flows through notches or grooves in the main bearings to lubricate the crankshaft journals. A jiggle pin in the main oil gallery front plug allows any air that may be trapped in the oil to escape. The timing chain and sprockets are splash lubricated by oil from the jiggle pin.

The crankshaft is drilled from the main bearings to the connecting rod bearings.

A small groove is located in the connecting rod at the mating face where the cap contacts the connecting rod. This groove is used as an oil squirt hole for cylinder wall lubrication. Oil from the connecting rod squirt hole lubricates the opposite cylinder wall. For example, the No. 1 connecting rod oils No. 5 cylinder, etc. As the crankshaft turns, the hole in the connecting rod bearing aligns with the hole in the journal causing a direct squirt of oil onto the cylinder wall.

Oil passages are drilled from the main oil gallery to each valve lifter

oil gallery. Oil from here feeds the valve lifter assemblies. A reservoir at each valve lifter bore boss traps oil so that oil is available for valve lifter lubrication as soon as the engine starts.

An oil passage is drilled from No. 2 camshaft bearing web to the left cylinder head between Nos. 5 and 6 cylinders to lubricate the valve rocker arm shaft assembly (Fig. 9). The oil passage in the cylinder head is drilled from the cylinder head bolt bore to the No. 2 valve rocker arm shaft support.

The oil flows through the valve rocker arm shaft through drilled holes in each valve rocker arm to lubricate the bushing and both ends of the valve rocker arm. The excess oil spirals down the rotating push rods and lubricates the push rod seats. The right valve rocker arm shaft assembly is similarly lubricated from No. 4 camshaft bearing via the No. 4 valve rocker arm shaft support.

A baffle located under the valve rocker arm shaft assembly shields the valve stems from oil splash. Excess oil is returned to the oil pan through drain-back holes located at each end

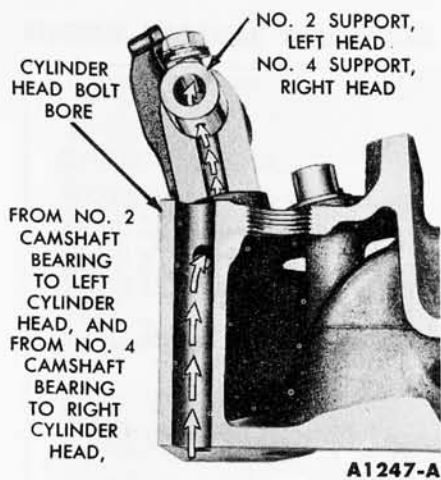
**100% SATISFACTION GUARANTEED**

**BUY IT NOW!**

**Click Here To Order**

Each Camshaft Bearing is Sold Individually

PayPal   American Express   Discover   MasterCard   VISA



**FIG. 9—Valve Rocker Arm Shaft Lubrication**

of the cylinder head and in the push rod chamber floor.

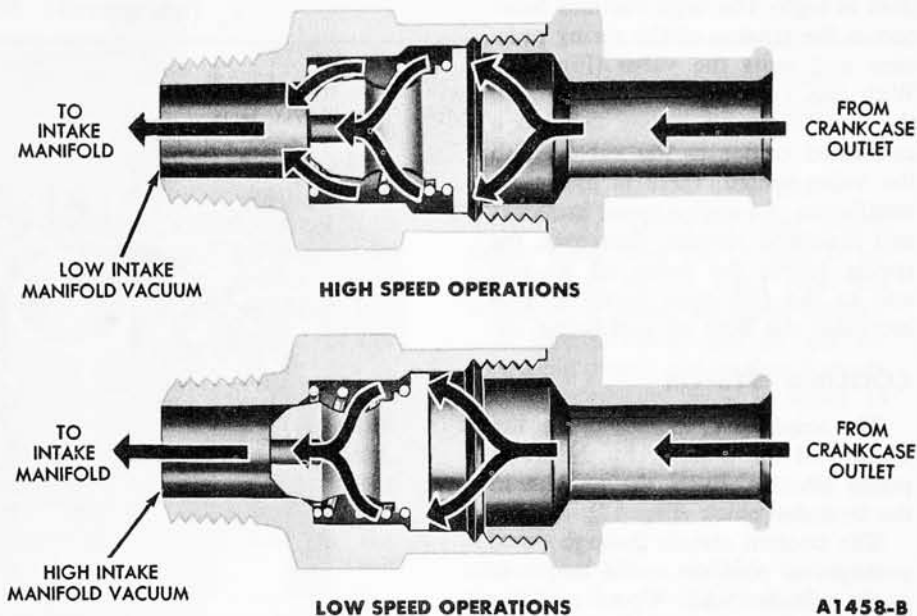
**CRANKCASE VENTILATION**

The engine has either a vent tube-type crankcase ventilation system or a positive crankcase ventilation system.

**VENT TUBE-TYPE CRANKCASE VENTILATION SYSTEM**

A crankcase ventilation tube is located at the rear of the engine. The forward motion of the car causes a partial vacuum to be formed at the tube outlet. This vacuum action causes air to be drawn through the engine from the oil filler cap located at the front of the intake manifold (Fig. 10). The filler cap contains a filtering element which filters the incoming air.

From the filler cap, the air flows into the front section of the valve



**FIG. 11—Positive Crankcase Ventilation Regulator Valve**

push rod chamber where there are few contaminating vapors. Here, the incoming air has a chance to warm up before contacting contaminating vapors originating in the crankcase. Warm ventilating air minimizes the formation of crankcase sludge.

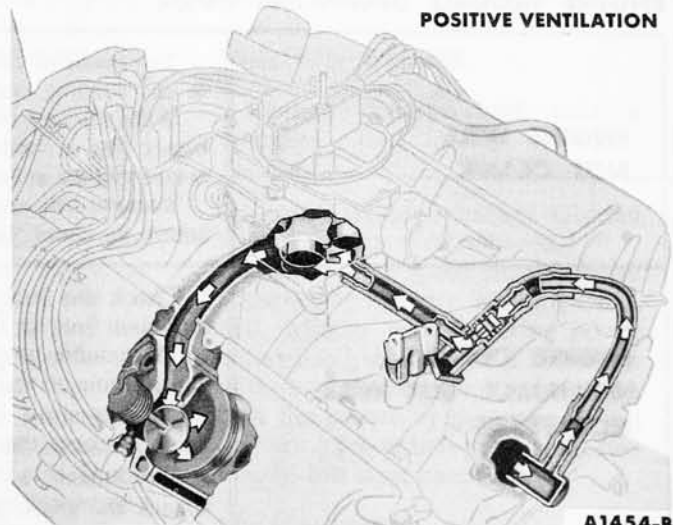
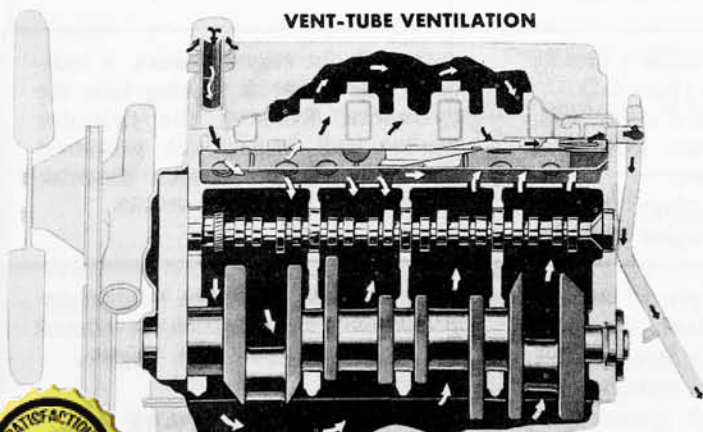
The ventilating air is directed by a baffle, located on the underside of the intake manifold, upward into the front of both valve rocker arm chambers. The baffle also directs air to the front of the lower crankcase and into the timing chain chamber.

Air from the valve rocker arm chamber and from the crankcase flows into the rear of the valve push rod chamber. All air is then directed out the crankcase ventilation tube.

**POSITIVE CRANKCASE VENTILATION SYSTEM**

Ventilating air enters the engine in the normal manner through the breather cap and is distributed through the engine in the same manner as in the vent tube-type system. However, instead of the ventilating air being discharged to the atmosphere, it is directed into the intake manifold thru the carburetor spacer. The air is directed into the intake manifold through an exhaust tube which extends from the crankcase ventilation outlet to a spring-loaded regulator valve and then into the carburetor spacer (Fig. 10). The valve regulates the amount of air to meet changing operating conditions.

During idle, intake manifold vac-



**100% SATISFACTION GUARANTEED**

**BUY IT NOW!**

**Click Here To Order**

PayPal, American Express, Discover, MasterCard, VISA

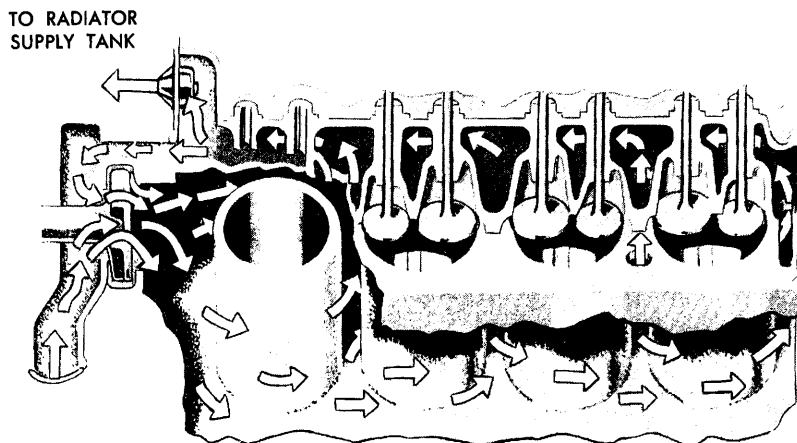
uum is high. The high vacuum overcomes the tension of the spring pressure and seats the valve (Fig. 11). With the valve in this position, all the ventilating air passes through a calibrated orifice in the valve. With the valve seated, there is minimum ventilation. As engine speed increases and manifold vacuum decreases, the spring forces the valve off its seat and to the full open position. This increases the flow of ventilating air.

**COOLING SYSTEM**

The coolant is drawn from the bottom of the radiator by the water pump which delivers the coolant to the cylinder block (Fig. 12).

The coolant travels through cored passages to cool the entire length of each cylinder wall. Upon reaching the rear of the cylinder block, the coolant is directed upward into the cylinder heads where it cools the combustion chambers, valves, and valve seats on its return to the front of the engine.

The coolant from each cylinder head flows through the water passages in the intake manifold and past the water thermostat, if it is open, into the radiator supply tank. If the thermostat is closed, a small



A1249-B

**FIG. 12—Cooling System**

portion of the coolant is returned to the water pump for recirculation.

The entire system is pressurized to 12-15 psi.

**2 ENGINE TROUBLE DIAGNOSIS**

Engine performance complaints usually fall under one of the basic headings listed in the "Engine Trouble Diagnosis Guide." When a particular trouble can not be traced to a definite cause by a simple check,

the possible items that could be at fault are listed in the order of their probable occurrence. Check the items in the order listed. For example, under "Poor Acceleration," the ignition system is listed as a probable

cause of the trouble. All the ignition system items that affect acceleration are listed. Check all these items before proceeding to the next probable cause.

**ENGINE TROUBLE DIAGNOSIS GUIDE**

<p><b>ENGINE WILL NOT CRANK</b></p>	<p>The cause of this trouble is usually in the starting system (Part 9-2). If the starting system is not at fault, check for a hydrostatic lock or a seized engine as follows: Remove the spark plugs, then attempt to crank the engine with the</p>	<p>starter. If the engine cranks, it indicates that water is leaking into the cylinders. Remove the cylinder head(s) and inspect the gaskets(s) and/or head(s) for cracks. Examine the cylinder block for cracks.</p>
<p><b>ENGINE CRANKS NORMALLY, BUT WILL NOT START</b></p>	<p>Check the fuel supply. If there is sufficient fuel in the tank, the cause of the trouble probably lies in either the ignition or the fuel system. To determine which system is at fault, perform the following test: Disconnect a spark plug wire. Check the spark intensity at the end of the wire by installing a terminal adapter in the terminal of the wire</p>	<p>to be checked. Hold the adapter approximately <math>\frac{3}{16}</math> inch from the exhaust manifold and crank the engine. <b>IF THERE IS NO SPARK OR A WEAK SPARK AT THE SPARK PLUGS</b> The cause of the trouble is in the ignition system.</p>

**100% SATISFACTION GUARANTEED**  
**BUY IT NOW!**  
**Click Here To Order**

ENGINE TROUBLE DIAGNOSIS GUIDE (Continued)

<p><b>ENGINE CRANKS NORMALLY, BUT WILL NOT START (Continued)</b></p>	<p>To determine if the cause of the trouble is in the primary or the secondary circuit, remove the coil high tension lead from the top of the distributor and hold it approximately <math>\frac{3}{16}</math> inch from the cylinder head. With the ignition on, crank the engine and check for a spark.</p> <p>If the spark at the coil high tension lead is good, the cause of the trouble is probably in the distributor cap or rotor.</p> <p>If there is no spark or a weak spark at the coil high tension lead, the cause of the trouble is probably in the primary circuit, coil to distributor high tension lead, or the coil.</p> <p><b>IF THERE IS A GOOD SPARK AT THE SPARK PLUGS</b></p> <p>Check the spark plugs. If the spark plugs are not at fault, check the following items:</p> <p><b>AUTOMATIC CHOKE</b></p> <p>Check the position of the choke plate. If the engine is hot, the plate should be open. If the plate is not open, the engine will load up due to the excessively rich mixture and will not start. If the engine is cold, the plate should be closed. If the plate is not operating properly, check the following items:</p> <p>The choke linkage for binding.</p>	<p>The fast idle cam for binding. Thermostatic spring housing adjustment.</p> <p><b>FUEL SUPPLY AT THE CARBURETOR</b></p> <p>Work the throttle by hand several times. Each time the throttle is actuated, fuel should spurt from the accelerating pump discharge nozzles.</p> <p>If fuel is discharged by the accelerating pump, the engine is probably flooded, or there is water in the fuel system, or an engine mechanical item is at fault.</p> <p>If fuel is not discharged by the accelerating pump, disconnect the carburetor fuel inlet line at the carburetor. Use a suitable container to catch the fuel. Crank the engine to see if fuel is reaching the carburetor.</p> <p>If fuel is not reaching the carburetor, check:</p> <ul style="list-style-type: none"> <li>The fuel filter.</li> <li>The fuel pump.</li> <li>The carburetor fuel inlet line for obstructions.</li> <li>The fuel pump flexible inlet line for a collapsed condition.</li> <li>The fuel tank line for obstructions.</li> <li>The fuel tank vent.</li> </ul> <p>If fuel is reaching the carburetor, check:</p> <ul style="list-style-type: none"> <li>The fuel inlet system including the fuel inlet needle and seat assembly, and the float assembly.</li> </ul>
<p><b>ENGINE STARTS, BUT FAILS TO KEEP RUNNING</b></p>	<p><b>FUEL SYSTEM</b></p> <ul style="list-style-type: none"> <li>Idle fuel mixture needles not properly adjusted.</li> <li>Engine idle speed set too low.</li> <li>The choke not operating properly.</li> <li>Float setting incorrect.</li> <li>Fuel inlet system not operating properly.</li> <li>Dirt or water in fuel lines or in the fuel filter.</li> </ul>	<ul style="list-style-type: none"> <li>Carburetor icing.</li> <li>Fuel pump defective.</li> <li>Dirt in the carburetor, not allowing fuel to enter or be discharged from the idle system.</li> </ul> <p><b>IGNITION SYSTEM</b></p> <ul style="list-style-type: none"> <li>Leakage in the high tension wiring.</li> </ul>
<p><b>ENGINE RUNS, BUT MISSES</b></p>	<p>Determine if the miss is steady or erratic and at what speed the miss occurs by operating the engine at various speeds under load.</p> <p><b>MISSES STEADILY AT ALL SPEEDS</b></p> <p>Isolate the miss by operating the engine with one cylinder not firing. This is done by operating the engine with the ignition wire removed from one spark plug at a time, until all</p>	<p>cylinders have been checked. Ground the spark plug wire removed.</p> <p>If the engine speed changes when a particular cylinder is shorted out, that cylinder was delivering power before being shorted out. If no change in the engine operation is evident, the miss was caused by that cylinder not delivering power before being shorted out. In this case, check the:</p> <p><b>IGNITION SYSTEM</b></p> <ul style="list-style-type: none"> <li>If the miss is isolated in a particu-</li> </ul>

**100% SATISFACTION GUARANTEED**

**BUY IT NOW!**

**Click Here To Order**

PayPal American Express Discover MasterCard VISA

## ENGINE TROUBLE DIAGNOSIS GUIDE (Continued)

<p><b>ENGINE RUNS, BUT MISSES (Continued)</b></p>	<p>lar cylinder, perform a spark test on the ignition lead of that cylinder.</p> <p>If a good spark does not occur, the trouble is in the secondary circuit of the system. Check the spark plug wire and the distributor cap.</p> <p>If a good spark occurs, check the spark plug. If the spark plug is not at fault, a mechanical component of the engine is probably at fault.</p> <p><b>ENGINE</b></p> <p>Perform a compression test to determine which mechanical component of the engine is at fault.</p> <p><b>MISSES ERRATICALLY AT ALL SPEEDS</b></p> <p><b>EXHAUST SYSTEM</b></p> <p>Exhaust system restricted.</p> <p><b>IGNITION SYSTEM</b></p> <p>Defective breaker points, condenser, secondary wiring, coil, or spark plugs.</p> <p>High tension leakage across the coil, rotor, or distributor cap.</p> <p><b>FUEL SYSTEM</b></p> <p>Float setting incorrect.</p> <p>Fuel inlet system not operating properly.</p> <p>Dirt or water in fuel lines or carburetor.</p> <p>Restricted fuel filter.</p> <p><b>COOLING SYSTEM</b></p> <p>Check the cooling system for in-</p>	<p>ternal leakage and/or for a condition that prevents the engine from reaching normal operating temperature.</p> <p><b>ENGINE</b></p> <p>Perform a compression test to determine which mechanical component of the engine is at fault.</p> <p><b>MISSES AT IDLE ONLY</b></p> <p><b>FUEL SYSTEM</b></p> <p>Idle fuel mixture needles not properly adjusted.</p> <p><b>IGNITION SYSTEM</b></p> <p>Excessive play in the distributor shaft.</p> <p>Worn distributor cam.</p> <p><b>ENGINE</b></p> <p>Perform a compression test to determine which mechanical component of the engine is at fault.</p> <p><b>MISSES AT HIGH SPEED ONLY</b></p> <p><b>FUEL SYSTEM</b></p> <p>Power valve clogged or damaged.</p> <p>Low or erratic fuel pump pressure.</p> <p>Fuel inlet system not operating properly.</p> <p>Restricted fuel filter.</p> <p><b>COOLING SYSTEM</b></p> <p>Engine overheating.</p>
<p><b>ROUGH ENGINE IDLE</b></p>	<p><b>FUEL SYSTEM</b></p> <p>Engine idle speed set too low.</p> <p>Idle fuel mixture needles not properly adjusted.</p> <p>Idle compensator malfunction.</p> <p>Float setting incorrect.</p> <p>Air leaks between the carburetor, spacer, and the manifold and/or fittings.</p> <p>Power valve leaking fuel.</p> <p>Idle fuel system air bleeds or fuel passages restricted.</p> <p>Fuel bleeding from the accelerating pump discharge nozzles.</p> <p>Secondary throttle plates not closing.</p> <p>Improper secondary throttle plate stop adjustment.</p> <p>Leaking fuel pump, lines, or fittings.</p>	<p><b>IGNITION SYSTEM</b></p> <p>Improperly adjusted or defective breaker points.</p> <p>Fouled or improperly adjusted spark plugs.</p> <p>Incorrect ignition timing.</p> <p>Spark plug misfiring.</p> <p><b>ENGINE</b></p> <p>Loose engine mounting bolts or worn insulator.</p> <p>Cylinder head bolts not properly torqued.</p> <p>Crankcase ventilation regulator valve defective or a restricted exhaust tube.</p>



**BUY IT NOW!**

**Click Here To Order**



CONTINUED ON NEXT PAGE

**ENGINE TROUBLE DIAGNOSIS GUIDE (Continued)**

<p><b>POOR ACCELERATION</b></p>	<p><b>IGNITION SYSTEM</b></p> <p>Incorrect ignition timing. Fouled or improperly adjusted spark plugs. Improperly adjusted or defective breaker points. Distributor not advancing properly.</p> <p><b>FUEL SYSTEM</b></p> <p>Inoperative accelerating pump inlet ball check. Inoperative accelerating pump discharge ball check. Accelerating pump diaphragm defective. Float setting incorrect. Throttle linkage not properly adjusted.</p>	<p>Accelerating pump stroke not properly adjusted. Leaky power valve, gaskets, or accelerating pump diaphragm. Dirt or corrosion in accelerating system. Distributor vacuum passages in the carburetor blocked. Restricted fuel filter.</p> <p><b>BRAKES</b></p> <p>Improper adjustment.</p> <p><b>TRANSMISSION</b></p> <p>Improper band adjustment. Converter One-Way Clutch.</p>
<p><b>ENGINE DOES NOT DEVELOP FULL POWER, OR HAS POOR HIGH SPEED PERFORMANCE</b></p>	<p><b>FUEL SYSTEM</b></p> <p>Restricted air cleaner. Restricted fuel filter. Clogged or undersize main jets and/or low float setting. Clogged or undersize secondary jets. Power valve clogged or damaged. Secondary throttle plates not opening. Fuel pump pressure incorrect. Distributor vacuum passage in the carburetor blocked.</p> <p><b>IGNITION SYSTEM</b></p> <p>Ignition timing not properly adjusted. Defective coil, condenser, or rotor. Distributor not advancing properly. Excessive play in the distributor shaft. Distributor cam worn. Fouled or improperly adjusted spark plugs.</p>	<p>Improperly adjusted or defective breaker points.</p> <p><b>COOLING SYSTEM</b></p> <p>Thermostat inoperative or incorrect heat range. Check the cooling system for internal leakage and/or for a condition that prevents the engine from reaching normal operating temperature.</p> <p><b>EXHAUST SYSTEM</b></p> <p>Restriction in system.</p> <p><b>ENGINE</b></p> <p>Perform an engine compression test to determine which mechanical component is at fault. One or more camshaft lobes worn beyond wear limit.</p> <p><b>TRANSMISSION</b></p> <p>Improper band adjustment.</p>

**100% SATISFACTION GUARANTEED**

**BUY IT NOW!**

**Click Here To Order**

PayPal American Express Discover MasterCard VISA

**ENGINE TROUBLE DIAGNOSIS GUIDE (Continued)**

<p><b>EXCESSIVE FUEL CONSUMPTION</b></p>	<p>Determine the actual fuel consumption with test equipment installed in the car.</p> <p>If the test indicates that the fuel consumption is not excessive, demonstrate to the owner how improper driving habits will affect fuel consumption.</p> <p>If the test indicates that the fuel consumption is excessive, make a preliminary check of the following items before proceeding to the fuel and ignition systems.</p> <p><b>PRELIMINARY CHECKS</b></p> <p><b>CHASSIS ITEMS</b></p> <p>Check:</p> <ul style="list-style-type: none"> <li>Tires for proper pressure.</li> <li>Front wheel alignment.</li> <li>Brake adjustment.</li> </ul> <p><b>EXHAUST SYSTEM</b></p> <ul style="list-style-type: none"> <li>System restricted.</li> </ul> <p><b>ODOMETER</b></p> <ul style="list-style-type: none"> <li>Check calibration.</li> </ul> <p><b>IGNITION SYSTEM</b></p> <p>Check:</p> <ul style="list-style-type: none"> <li>Distributor breaker points.</li> <li>Ignition timing.</li> </ul> <p><b>ENGINE</b></p> <ul style="list-style-type: none"> <li>Crankcase ventilation regulator valve defective or restricted exhaust tube.</li> </ul>	<p><b>FINAL CHECKS</b></p> <p><b>FUEL SYSTEM</b></p> <p>Check:</p> <ul style="list-style-type: none"> <li>Fuel pump pressure.</li> <li>Engine idle speed.</li> <li>Idle fuel mixture needles for proper adjustment.</li> <li>Automatic choke for proper operation.</li> <li>Fast idle speed screw for proper adjustment.</li> <li>Accelerating pump stroke adjustment.</li> <li>Anti-stall dashpot for proper adjustment.</li> <li>Air cleaner for restrictions.</li> <li>Float setting.</li> <li>Jets for wear and/or damage.</li> <li>Power valve operation.</li> <li>Air bleeds for obstructions.</li> <li>Accelerating pump discharge nozzles for siphoning.</li> <li>Accelerator linkage for binds.</li> <li>Choke adjustment.</li> </ul> <p><b>IGNITION SYSTEM</b></p> <p>Check:</p> <ul style="list-style-type: none"> <li>Spark plug condition and adjustment.</li> <li>Distributor spark advance operation.</li> </ul> <p><b>ENGINE</b></p> <ul style="list-style-type: none"> <li>Perform an engine compression test to determine which mechanical component of the engine is at fault.</li> </ul> <p><b>COOLING SYSTEM</b></p> <ul style="list-style-type: none"> <li>Check thermostat operation and heat range.</li> </ul> <p><b>TRANSMISSION</b></p> <ul style="list-style-type: none"> <li>Check band adjustment.</li> </ul>
<p><b>ENGINE OVERHEATS</b></p>	<p><b>TEMPERATURE SENDING UNIT AND GAUGE</b></p> <p>Unit or gauge defective (not indicating correct temperature), or constant voltage regulator defective.</p> <p><b>ENGINE</b></p> <ul style="list-style-type: none"> <li>Cylinder head bolts not properly torqued.</li> </ul>	<ul style="list-style-type: none"> <li>Low oil level or incorrect viscosity oil used.</li> </ul> <p><b>COOLING SYSTEM</b></p> <ul style="list-style-type: none"> <li>Insufficient coolant.</li> <li>Cooling system leaks.</li> <li>Drive belt tension incorrect.</li> <li>Radiator fins obstructed.</li> </ul>

**ENGINE TROUBLE DIAGNOSIS GUIDE (Continued)**

<p><b>ENGINE OVERHEATS (Continued)</b></p>	<p>Thermostat defective. Thermostat improperly installed. Cooling system passages blocked. Water pump inoperative.</p>	<p>Faulty fan drive. <b>IGNITION SYSTEM</b> Incorrect ignition timing.</p>
<p><b>LOSS OF COOLANT</b></p>	<p><b>COOLING SYSTEM</b> Leaking radiator. Loose or damaged hose connections. Water pump leaking. Radiator cap defective. Overheating. <b>ENGINE</b> Cylinder head gasket defective.</p>	<p>Intake manifold to cylinder head gasket defective. Cylinder head or intake manifold bolts not properly torqued. Cylinder block core plugs leaking. Temperature sending unit leaking. Cracked cylinder head or block, or warped cylinder head or block gasket surface.</p>
<p><b>ENGINE FAILS TO REACH NORMAL OPERATING TEMPERATURE</b></p>	<p><b>TEMPERATURE SENDING UNIT AND GAUGE</b> Unit or gauge defective (not indicating correct temperature) or constant voltage regulator defective.</p>	<p><b>COOLING SYSTEM</b> Thermostat inoperative or of incorrect heat range.</p>
<p><b>NOISY HYDRAULIC VALVE LIFTER</b></p>	<p>A noisy valve lifter can be located by operating the engine at idle speed and placing a finger on the face of the valve spring retainer. If the lifter is not functioning properly, a shock will be felt when the valve seats. Another method of identifying a noisy lifter is by the use of a piece of hose. With the engine operating at idle speed, place one end of the hose near the end of the valve stem and the other end to the ear and listen for a metallic noise. Repeat this procedure on each intake and exhaust valve until the noisy lifter(s) has been located. The most common causes of hydraulic valve lifter troubles are dirt, gum, varnish, carbon deposits, and air bubbles. Dirt in the lifter assembly can prevent the disc valve from seating, or it may become lodged between the plunger and body surfaces. In either case, the lifter becomes inoperative due to failure to “pump-up,” or because the internal parts are no</p>	<p>longer free to function properly. When dirt is found to be responsible for lifter malfunction, remove the lifter assembly and thoroughly clean it. Recommended engine oil and filter change intervals should be followed to minimize lifter problems caused by dirt. Deposits of gum and varnish cause similar conditions to exist which may result in lifter malfunction. If these conditions are found to be present, the lifter should be disassembled and cleaned in solvent to remove all traces of deposits. Air bubbles in the lubricating oil, caused by an excessively high or low oil level, may likewise cause lifter malfunction. A damaged oil pick-up tube may allow air to be drawn into the lubricating system. To check for the presence of air, remove a valve rocker arm cover and note the condition of the oil as it flows from the valve rocker arm shaft assembly. Perform corrective action as required to remove air from the lubricating oil.</p>

**100% SATISFACTION GUARANTEED**

**BUY IT NOW!**

**Click Here To Order**

PayPal American Express Discover MasterCard VISA

### 3 ENGINE TESTS AND ADJUSTMENTS

#### CAMSHAFT LOBE LIFT

1. Remove the air cleaner and the valve rocker arm cover. Remove the valve rocker arm shaft assembly and install a solid tappet-type push rod in the push rod bore of the camshaft lobe to be checked.

2. Make sure the push rod is in the lifter push rod cup. Install a dial indicator in such a manner as to have the actuating point of the indicator in the push rod socket and in the same plane as the push rod movement (Fig. 13).

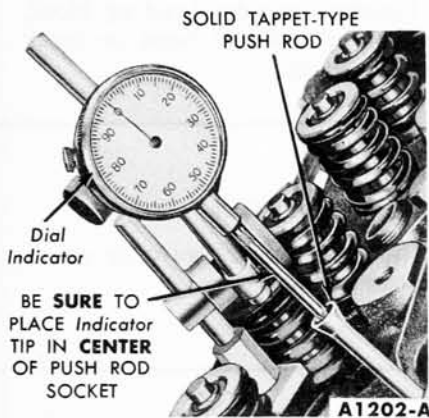


FIG. 13—Camshaft Lobe Lift

3. Turn the crankshaft damper slowly in the direction of rotation until the lifter is on the base circle of the camshaft lobe. At this point, the push rod will be in its lowest position.

4. Zero the dial indicator.

5. Continue to rotate the damper slowly until the push rod is in the fully raised position.

6. Compare the total lift recorded on the indicator with specifications.

7. To check on the accuracy of the original indicator reading, continue to rotate the crankshaft until the indicator reads zero.

8. Remove the dial indicator.

9. Install the valve rocker arm shaft. Install the rocker arm cover and the air cleaner.

#### VALVE CLEARANCE

0.060-inch shorter push rod

mechanism. Valve stem to valve rocker arm clearance should be 0.078-0.218 inch with the hydraulic lifter completely collapsed. Repeated valve reconditioning operations (valve and/or valve seat refacing) will decrease this clearance to the point that if not compensated for, the hydraulic valve lifter will cease to function.

To determine whether a shorter or a longer push rod is necessary, make the following check:

1. Position the crankshaft as outlined in steps 5 and 6.

2. Position the hydraulic lifter compressor tool on the rocker arm and slowly apply pressure to bleed down the hydraulic lifter until the plunger is completely bottomed (Fig. 14). Hold the lifter in the fully collapsed position.

3. Insert the correct end of the clearance gauge between the valve stem and the rocker arm of the valve being checked.

4. If the first step of the gauge enters, a standard length push rod may be used.

If the first step of the gauge does not enter, replace the standard push rod with a 0.060-inch shorter service push rod.

If the second step of the gauge enters, the operating range of the lifter is excessive. This indicates that the incorrect push rod has been installed or severe wear has occurred at the push rod ends, rocker arm, or valve stem. In this case, it will be necessary to determine the area of discrepancy and the incorrect or defective part(s) should be replaced.

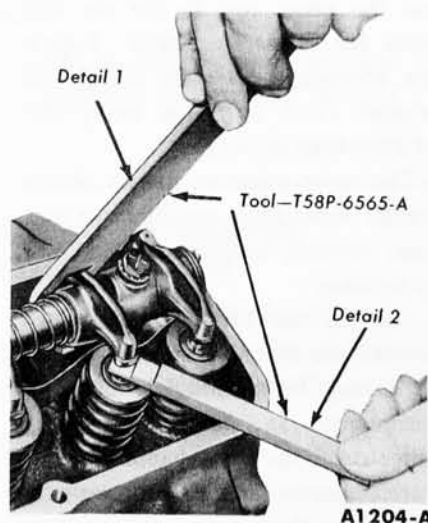


FIG. 14—Valve Clearance

If all the valve train components except the push rod are within limits, install a 0.060-inch longer push rod.

5. Rotate the crankshaft until No. 1 piston is on TDC at the end of the compression stroke. With No. 1 piston on TDC, check the following valves:

No. 1 Intake	No. 1 Exhaust
No. 3 Intake	No. 4 Exhaust
No. 7 Intake	No. 5 Exhaust
No. 8 Intake	No. 8 Exhaust

6. Position No. 6 piston on TDC and check the following valves:

No. 2 Intake	No. 2 Exhaust
No. 4 Intake	No. 3 Exhaust
No. 5 Intake	No. 6 Exhaust
No. 6 Intake	No. 7 Exhaust

**When compressing the valve spring to remove push rods, be sure the piston in the individual cylinder is below TDC to avoid contact between the valve and the piston.**

To replace a push rod, it will be necessary to remove the valve rocker arm shaft assembly.

Upon replacement of a valve push rod and/or valve rocker arm shaft assembly, the engine should not be cranked or rotated until the hydraulic lifters have had an opportunity to leak down to their normal operating position. The leak-down rate can be accelerated by using the tool shown in Fig. 14 on the valve rocker arm and applying pressure in a direction to collapse the lifter.

#### MANIFOLD VACUUM TEST

A manifold vacuum test aids in determining the condition of an engine and also in helping to locate the cause of poor engine performance. To test manifold vacuum:

1. Operate the engine for a minimum of 30 minutes at 1200 rpm.

2. Install an accurate, sensitive vacuum gauge in the fitting in the intake manifold.

3. Operate the engine at recommended idle rpm, with the transmission selector lever in neutral.

4. Check the vacuum reading on the gauge.

#### TEST CONCLUSIONS

Manifold vacuum is affected by carburetor adjustment, valve timing, the condition of the valves, cylinder

100% SATISFACTION GUARANTEED

**BUY IT NOW!**

Click Here To Order

PayPal, American Express, Discover, MasterCard, VISA

compression, and leakage of the manifold, carburetor, carburetor spacer, or cylinder head gaskets.

Because abnormal gauge readings may indicate that more than one of the above factors is at fault, exercise caution in analyzing an abnormal reading. For example, if the vacuum is low, the correction of one item may increase the vacuum enough to indicate that the trouble has been corrected. It is important, therefore, that each cause of an abnormal reading be investigated and further tests conducted where necessary in order to arrive at the correct diagnosis of the trouble.

Table 2 lists various types of readings and their possible causes.

Allowance should be made for the effect of altitude on the gauge reading. The engine vacuum will decrease with an increase in altitude.

### COMPRESSION TEST

1. Be sure the battery is properly charged. Operate the engine for a minimum of 30 minutes at 1200 rpm. Turn the ignition switch off, then remove all the spark plugs. Remove the coil high tension lead at the distributor cap.

2. Set the primary throttle plates and choke plate in the wide open position.

3. Install a compression gauge in No. 1 cylinder.

4. Using a remote starter switch, crank the engine several times and record the highest reading recorded. Note the number of compression strokes required to obtain the highest reading.

5. Repeat the test on each cylinder, cranking the engine the same number of times for each cylinder as was required to obtain the highest reading on the No. 1 cylinder.

**TABLE 2—Manifold Vacuum Gauge Readings**

Gauge Reading	Engine Condition
18 inches	Normal.
Low and steady.	Loss of power in all cylinders caused possibly by late ignition or valve timing, or loss of compression due to leakage around the piston rings.
Very low.	Manifold, carburetor, spacer, or cylinder head gasket leak.
Needle fluctuates steadily as speed increases.	A partial or complete loss of power in one or more cylinders caused by a leaking valve, cylinder head or intake manifold gasket leak, a defect in the ignition system, or a weak valve spring.
Gradual drop in reading at engine idle.	Excessive back pressure in the exhaust system.
Intermittent fluctuation.	An occasional loss of power possibly caused by a defect in the ignition system or a sticking valve.
Slow fluctuation or drifting of the needle.	Improper idle mixture adjustment, carburetor, spacer, or intake manifold gasket leak, or possibly late valve timing.

### TEST CONCLUSIONS

A variation of  $\pm 20$  pounds from specified pressure is satisfactory. However, the compression of all cylinders should be uniform within 10 pounds.

A reading of more than the allowable tolerance above normal indicates excessive deposits in the cylinder.

A reading of more than the allowable tolerance below normal indicates leakage at the cylinder head gasket, piston rings, or valves.

A low even compression in two adjacent cylinders indicates a cylinder head gasket leak. This should be checked before condemning the rings or valves.

To determine whether the rings or

the valves are at fault, squirt the equivalent of a tablespoon of heavy oil into the combustion chamber. Crank the engine to distribute the oil and repeat the compression test. The oil will temporarily seal leakage past the rings. If approximately the same reading is obtained, the rings are satisfactory, but the valves are leaking. If the compression has increased 10 pounds or more over the original reading, there is leakage past the rings.

During a compression test, if the pressure fails to climb steadily and remains the same during the first two successive strokes, but climbs higher on the succeeding strokes, or fails to climb during the entire test, it indicates a sticking valve.

## 4 ENGINE REMOVAL AND INSTALLATION

The procedures given are for the engine without the transmission attached. If the engine and transmission are removed as an assembly, insert the head eye bolts with 1/2-14

### REMOVAL

1. Drain the cooling system and the crankcase. Remove the hood and the air cleaner.

2. Disconnect the radiator upper hose at the radiator supply tank and the radiator lower hose at the water pump.

3. Disconnect the transmission oil

cooler lines at the radiator. Remove the radiator and support as an assembly.

4. Disconnect the battery ground cable at the generator mounting bracket. Remove the oil level dipstick and the ignition coil.

5. Disconnect the oil pressure sending unit wire at the sending unit

**100% SATISFACTION GUARANTEED**

**BUY IT NOW!**

**Click Here To Order**

PayPal American Express Discover Novus MasterCard VISA

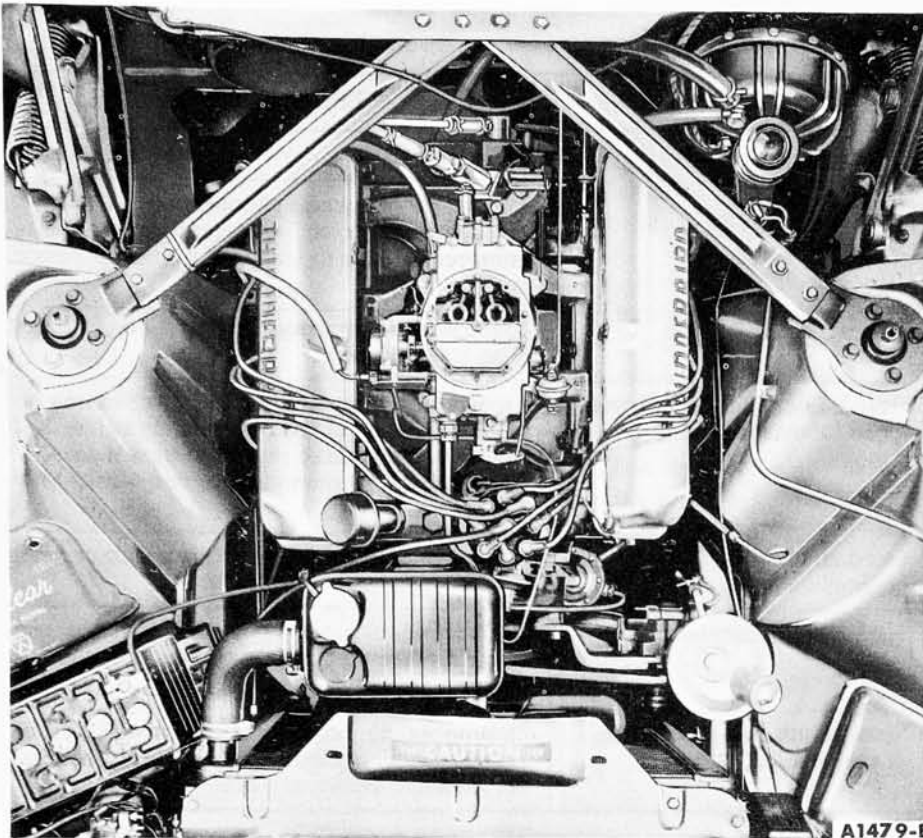


FIG. 15—Engine Installation

and the flexible fuel line at the fuel tank line.

6. Remove the wire loom from the clips on the left valve rocker arm cover and position the wires out of the way.

7. Disconnect the three windshield washer lines at the washer pump and position them out of the way.

8. Disconnect the accelerator rod at the carburetor. Remove the accelerator retracting spring. Remove the accelerator cross shaft bracket from the intake manifold and position it out of the way.

9. Disconnect the power steering pump bracket from the water pump, then wire the power steering pump to the hood left hinge in a position that will prevent the oil from draining out.

10. Disconnect the power brake line at the intake manifold and at the flexible line. Release the line from the brackets on the left valve rocker arm cover and remove the line.

11. Install the engine in a car with an air conditioner,

12. Disconnect the generator wires at the generator.

13. Disconnect the water temperature sending unit wire at the sending unit.

14. Remove the engine ground strap. Remove the starter cable retaining bracket from the generator mounting bracket.

15. Raise the front of the car.

16. Remove the starter and dust seal and the transmission fluid filler tube bracket.

17. Disconnect the muffler inlet pipes from the exhaust manifolds, and the engine right and left support insulators at the engine.

18. Remove the converter housing lower access cover and the cover assembly. Remove the flywheel to converter nuts. Secure the converter assembly in the housing. Remove the converter housing to engine lower bolts, and remove the oil cooler lines retaining clamp from the engine block.

19. Lower the car, then support the transmission. Remove the converter housing upper retaining bolts.

20. Install the engine left lifting bracket on the front of the left cylinder head where the coil mounts.

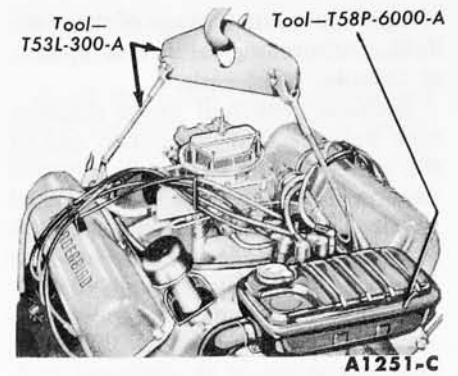


FIG. 16—Engine Lifting Brackets and Sling

Install the engine right lifting bracket at the rear of the right cylinder head. Attach the engine lifting sling (Fig. 16).

21. Raise the engine slightly and carefully pull it from the transmission.

22. Lift the engine out of the engine compartment and install it on a work stand (Fig. 17).

## INSTALLATION

1. Place a new gasket over the studs of the exhaust manifolds.

2. Attach the engine lifting brackets and sling (Fig. 16). Remove the engine from the work stand.

3. Lower the engine carefully into the engine compartment. Make sure the exhaust manifolds are properly aligned with the muffler inlet pipes and the dowels in the block engage the holes in the converter housing. Start the converter pilot into the crankshaft.

4. Install the converter housing upper bolts. Torque the bolts to specifications.

5. Start the engine right and left support insulator to engine bolts.

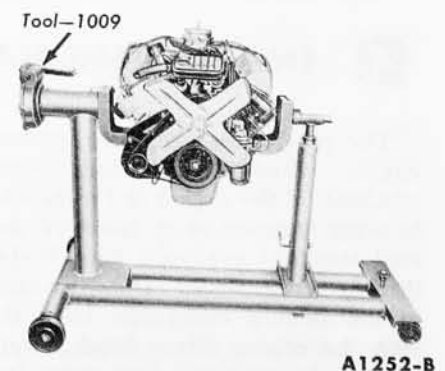


FIG. 17—Engine Work Stand

100% SATISFACTION GUARANTEED

**BUY IT NOW!**

Click Here To Order

PayPal Discover Cards Discover Novus MasterCard VISA

Disconnect the engine lifting sling and remove the lifting brackets.

6. Raise the front of the car. Install the converter housing lower retaining bolts. Torque the bolts to specifications.

7. Remove the retainer securing the converter in the housing. Install the flywheel to converter lock washers and nuts. Torque the nuts to specifications. Install the converter lower access plate and the housing cover assembly. Install the oil cooler lines retaining clamp.

8. Torque the engine front support insulator bolts to specifications.

9. Connect both exhaust manifolds to the muffler inlet pipes. Torque the nuts to specifications.

10. Position the dust seal and install the starter and the transmission fluid filler tube bracket.

11. Remove the support from the transmission and lower the car.

12. Connect the generator wires.

13. Connect the water temperature sending unit wire. Connect the heater hose at the intake manifold.

14. Connect the engine ground strap. Install the starter cable retaining clamp.

15. Connect the flexible fuel line, the oil pressure sending unit wire, and the windshield wiper vacuum line.

16. Install the ignition coil and connect the coil primary and high tension wires.

17. Install the oil level dipstick.

18. Position the wire loom in the retaining clips on the left valve rocker arm cover.

19. Connect the windshield washer pump lines.

20. Install the accelerator cross shaft bracket and the accelerator retracting spring. Connect the accelerator rod.

21. Connect the power steering pump bracket to the water pump.

22. Connect the power brake line to the intake manifold and to the flexible line. Install the line in the retaining clips on the left valve rocker arm cover.

On a car with an air conditioner, connect the magnetic clutch wire and the compressor lines.

23. Install the radiator and support as an assembly. Connect the radiator upper and lower hoses. Connect the transmission oil cooler lines.

24. Fill and bleed the cooling system. Connect the heater hose at the water pump.

25. Fill the crankcase with the proper grade and quantity of engine oil.

26. Operate the engine at fast idle and check all gaskets and hose connections for leaks.

27. Adjust the transmission control linkage. Install the air cleaner.

28. Install and adjust the hood.

## 5 IN-CHASSIS REPAIR OPERATIONS

### ENGINE SUPPORTS

The front supports are located on each side of the crankcase and the rear support is located at the transmission extension housing.

#### ENGINE FRONT SUPPORT

The engine front support is shown in Fig. 18. The procedures given apply to either a right or left installation.

#### Removal

1. Remove the insulator assembly to engine retaining bolts, and insulator to underbody retaining nut.

If only one support is being removed, loosen the other support.

2. Raise the engine about 1 inch with a jack and a block of wood placed under the oil pan, then remove the insulator assembly.

#### Installation

1. Position the insulator assembly. Install, but do not tighten, the insulator to engine lock washers and bolts. If the other engine supports have been removed, install the insulator bolts on the opposite side.

#### ENGINE REAR SUPPORT

The engine rear support is shown in Fig. 19.

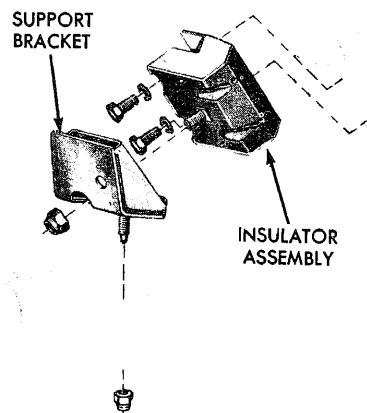
#### Removal

1. Remove the support retainer bolts and washers and remove the retainer.

2. Raise the extension housing slightly to relieve the pressure on the support assembly. Remove the support assembly.

#### Installation

1. Raise the extension housing



A1480-A

FIG. 18—Engine Front Support

enough to position the support assembly and retainer. Install the support retainer to extension housing washers and bolts. Torque the support retainer bolts to specifications.

### VALVE ROCKER ARM SHAFT ASSEMBLY

#### REMOVAL

1. Remove the air cleaner.

2. Disconnect the spark plug wires at the spark plugs. Remove the wires from the bracket on the valve rocker arm cover(s) and position the wires out of the way.

To remove the right valve rocker arm cover, remove the carburetor choke heat tube.

To remove the left valve rocker arm cover, disconnect the brake booster line and position the line out of the way.

3. Remove the valve rocker arm cover(s).

If the left cover is removed, position the wire loom out of the way.

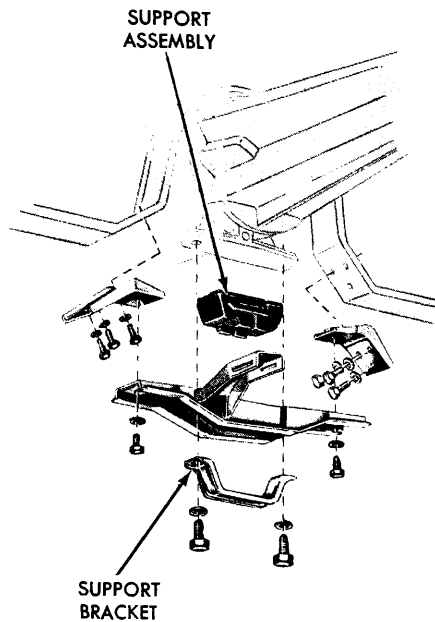
4. Crank the engine until the No. 1 piston is at TDC, at the end of the compression stroke. Rotate the crankshaft damper an additional 45° (identified by "XX" on the damper).

**100% SATISFACTION GUARANTEED**

**BUY IT NOW!**

**Click Here To Order**

PayPal, American Express, Discover, MasterCard, VISA



A1481-A

FIG. 19—Engine Rear Support

5. Starting at the No. 4 cylinder, loosen the right valve rocker arm shaft support bolts in sequence, two turns at a time. After the bolts are all loosened, remove the valve rocker arm shaft assembly and the oil baffle plate. Starting at the No. 5 cylinder, follow the same procedure on the left valve rocker arm shaft support bolts. **This procedure must be followed to avoid damage to the valve mechanism.**

**INSTALLATION**

1. Apply Lubriplate to the pad end of the rocker arms, to the tip of the valve stems, and to both ends of

the push rods.

2. Crank the engine until the No. 1 piston is on TDC at the end of the compression stroke.

3. Rotate the crankshaft damper an additional 45° (identified by "XX" on the damper).

4. Position the baffle plate and the valve rocker arm shaft assembly on the cylinder heads with the valve push rods in place and the rocker shaft support bolts finger-tight. **Be sure the shaft is turned so that the oil holes are to the bottom.**

5. Starting at the No. 4 cylinder, tighten the bolts in sequence, two turns at a time, until the supports fully contact the cylinder head. Torque the bolts in sequence to specifications.

6. Starting at the No. 5 cylinder, follow the same procedure for the left valve rocker arm shaft support bolts. The additional time consumed in this procedure will permit the hydraulic lifters to leak down. This will minimize the possibility of bending the push rods, valves, or the rocker arms. **Be sure that the hydraulic lifters have leaked down to their normal operating position before cranking the engine. This is necessary in order to avoid possible damage to the valves, push rods, or valve rocker arms.**

7. Clean the valve rocker arm cover(s). Apply oil resistant sealer to one side of new cover gasket(s). Lay the cemented side of the gasket(s) in place in the cover(s).

8. Position the cover(s) on the

cylinder head(s). Make sure the gasket seats evenly all around the head. Install the bolts (and the wire loom clamps on the left cover). The cover is tightened in two steps. First, torque the bolts to specifications. Two minutes later, torque the bolts to the same specifications.

If the left cover was removed, connect the brake booster vacuum line.

If the right cover was removed, install the carburetor choke heat tube.

9. Connect the spark plug wires. Install the air cleaner.

**DISASSEMBLY**

1. Remove the cotter pins from each end of the valve rocker arm shaft. Remove the flat washer and spring washer from each end of the shaft.

2. Slide the rocker arms, springs, and the supports off the shaft. Be sure to identify all the parts.

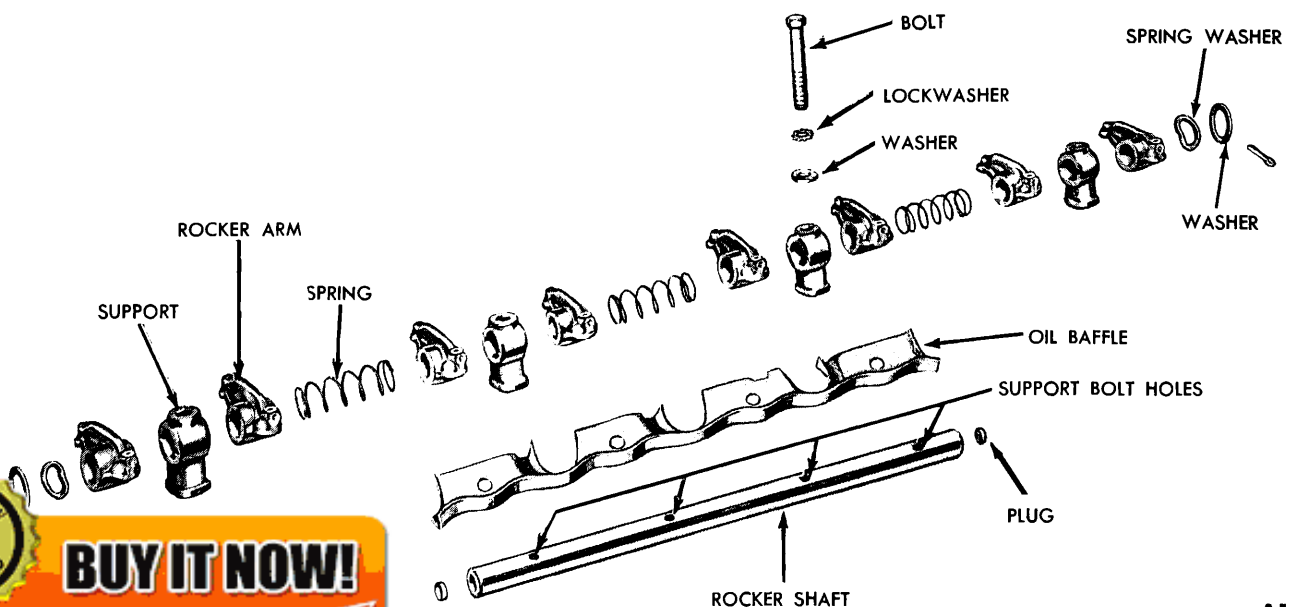
3. If it is necessary to remove the plugs from each end of the shaft, drill or pierce one plug. Insert a steel rod through the plug and knock out the plug on the opposite end. Working from the open end, knock out the remaining plug.

**ASSEMBLY**

1. Oil all the moving parts with engine oil. Apply Lubriplate to the pad of the valve rocker arms.

2. If the plugs were removed from the ends of the shaft, use a blunt tool or large diameter pin punch and install a plug, cup side out, in each end of the rocker arm shaft.

3. Install the rocker arms, supports, and springs in the order shown



A1261-B

**100% SATISFACTION GUARANTEED**

**BUY IT NOW!**

**Click Here To Order**

PayPal, American Express, Discover, MasterCard, VISA

in Fig. 20. Be sure the oil holes in the shaft are facing downward. Complete the assembly by installing the remaining flat washer and the spring washer and install the cotter pin.

**CLEANING AND INSPECTION**

Clean all the parts thoroughly. Make sure that all oil passages are open.

Check the clearance between each rocker arm and the shaft by checking the ID of the rocker arm bore and the OD of the shaft. If the clearance between any rocker arm and the shaft exceeds the wear limit, replace the shaft and/or the rocker arm. Inspect the shaft and the rocker arm bore for nicks, scratches, scores, or scuffs. Dress up minor surface defects with a hone.

Inspect the pad at the valve end of the rocker arms for a grooved radius. If the pad is grooved, replace the rocker arm. Do not attempt to true this surface by grinding.

Check for broken locating springs.

**INTAKE MANIFOLD REMOVAL**

1. Drain the cooling system. Remove the air cleaner.

2. Disconnect the accelerator rod at the carburetor. Remove the accelerator cross shaft bracket from the intake manifold and position it out of the way.

3. Remove the carburetor fuel inlet line and the automatic choke heat tube. Disconnect the brake vacuum booster line at the intake manifold and at the flexible hose. Remove the vacuum line.

4. Disconnect the coil high tension lead, and the coil wires at the coil. Disconnect the oil pressure sending unit wire at the sending unit. Remove the wire loom from the retaining clips on the left valve rocker arm cover and position it out of the way.

5. Disconnect the spark plug wires at the spark plugs and remove the wires from the ignition harness brackets on the valve rocker arm covers.

Remove the distributor cap and wire assembly. Discon-

8. Disconnect the radiator upper hose at the radiator supply tank, then remove the supply tank. Remove the heater hose at the intake manifold, and the water temperature sending unit wire at the sending unit.

9. Slide the clamp on the water pump by-pass hose toward the water pump.

10. Clean the outside of the valve rocker arm covers and remove the covers.

11. Refer to "Valve Rocker Arm Shaft Assembly Removal" and remove the valve rocker arm shaft

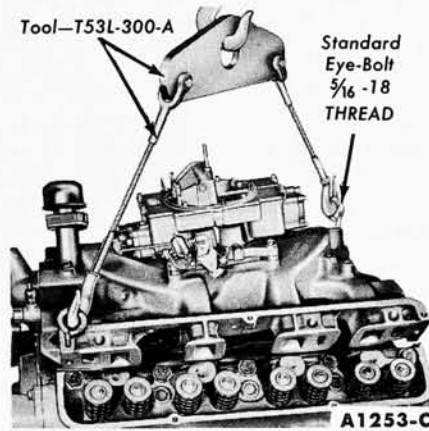


FIG. 21—Intake Manifold Removal or Installation

assembly by following steps 4 and 5.

12. Remove the valve push rods in sequence.

13. Remove the intake manifold retaining bolts.

14. Install standard eye bolts with 5/16-18 threads in the left front and right rear rocker arm cover screw holes. Attach the engine lifting sling (Fig. 21).

15. Raise the manifold and carefully remove the intake manifold and radiator supply tank as an assembly. Remove the intake manifold gaskets and seals.

16. If the manifold is to be disassembled, remove the radiator supply tank, thermostat, and gasket. Remove the carburetor, spacer, and gasket.

On an engine with positive crankcase ventilation, remove the crankcase ventilation regulator valve and exhaust tube.

**INSTALLATION**

The intake manifold assembly is shown in Fig. 22.

1. If the intake manifold was disassembled, install the carburetor, spacer, and gasket. Coat the thermostat gasket with water resistant sealer and place it in position on the intake

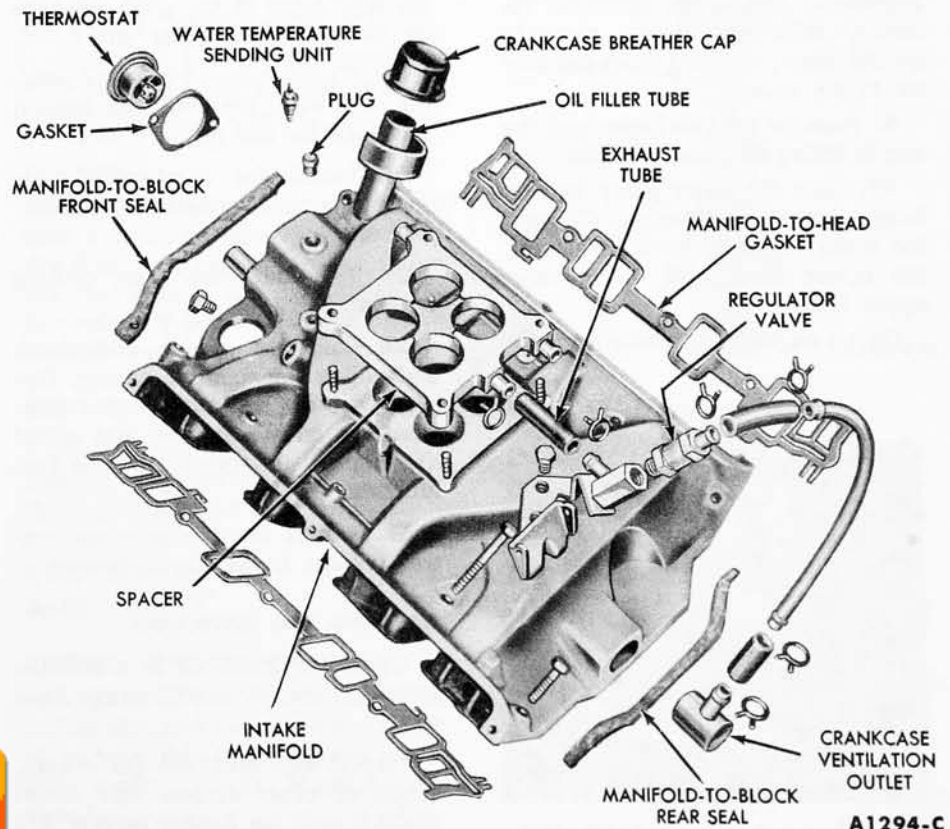


FIG. 22—Typical Intake Manifold Assembly

100% SATISFACTION GUARANTEED

**BUY IT NOW!**

Click Here To Order

PayPal, American Express, Discover, MasterCard, VISA

manifold. Install the thermostat and radiator supply tank.

2. Clean the mating surfaces of the intake manifold, cylinder heads, and cylinder block.

3. Coat the intake manifold and cylinder block seal surfaces with oil resistant sealer.

4. Position new seals on the cylinder block and new gaskets on the cylinder heads. Position the gasket slots in the end tabs over the ribs on the seals. Be sure the holes in the gaskets are aligned with the holes in the cylinder heads. The correct installation of the gaskets and seals is shown in Fig. 23.

5. Install the eye bolts in the intake manifold and attach the engine lifting sling and carefully lower the intake manifold on the engine (Fig. 21).

6. Position the intake manifold by inserting the distributor in place. **After the intake manifold is in place, run a finger around the seal area to make sure the seals are in place. If the seals are not in place, remove the intake manifold and reposition the seals.**

7. Start the water pump by-pass hose on the intake manifold.

8. Be sure the holes in the manifold gaskets and manifold are in alignment. Install the manifold retaining bolts and torque them to specifications, working from the center to the ends.

9. Remove the distributor and the engine lifting sling and eye bolts.

10. Slide the water pump by-pass hose clamp into position. Connect the water temperature sending unit, the heater hose, and the radiator upper hose.

On an engine with positive crank-

case ventilation, install the crankcase ventilation regulator valve and exhaust tube.

11. Apply Lubriplate to both ends of the push rods. Install the push rods in their original bores, positioning the lower ends of the rods in the lifter cups. Refer to "Valve Rocker Arm Shaft Assembly Installation" and install the valve rocker arm shaft assembly by following steps 1 thru 6.

12. Rotate the crankshaft damper until the No. 1 piston is on TDC at the end of the compression stroke. Position the distributor in the block with the rotor at the No. 1 firing position and the points open. Install the hold down clamp.

13. Clean the valve rocker arm covers. Apply oil resistant sealer to one side of new cover gaskets. Lay the cemented side of the gaskets in place in the covers. Install the valve rocker arm covers.

14. Connect the brake vacuum booster line and connect the flexible hose.

15. Install the carburetor fuel inlet line and connect the distributor vacuum line. Install the automatic choke heat tube.

16. Install the distributor cap. Connect the spark plug wires. Install the wire loom in the retaining clips on the left valve rocker arm cover.

17. Connect the oil pressure sending unit wire, the coil high tension lead, and the coil primary wire.

18. Install the accelerator cross shaft bracket. Connect the accelerator rod.

19. Fill and bleed the cooling system.

20. Start the engine and check and adjust the ignition timing. Operate the engine until engine temperatures have stabilized and adjust the engine idle speed and idle fuel mixture.

21. Adjust the transmission control linkage. Install the air cleaner.

#### CLEANING AND INSPECTION

Clean the manifold in a suitable solvent, then dry it with compressed air.

Inspect the manifold for cracks, leaks, or other defects that would make it unfit for further service. Replace all studs that are stripped or otherwise damaged. **Remove all fil-**

**ings and foreign matter that may have entered the manifold as a result of repairs.**

Check the baffle plate on the underside of the manifold for looseness and be sure the maze screen is in place. Clean off any varnish accumulation.

#### EXHAUST MANIFOLD

##### REMOVAL

1. Remove the air cleaner. Disconnect the exhaust manifold at the muffler inlet pipe.

2. Remove the automatic choke heat tube from the right exhaust manifold.

3. Disconnect the power steering pump bracket from the cylinder block and move it out of the way. Position the pump so that the oil will not drain out. Disconnect the power steering hose bracket and position the hoses out of the way.

4. Remove the dipstick and tube assembly.

5. Remove the retaining bolts and tab washers and remove the exhaust manifolds.

##### INSTALLATION

1. Clean the mating surfaces of the exhaust manifold and cylinder head. Scrape the gasket material from the mounting flange of the exhaust manifold and muffler inlet pipe.

2. Apply graphite grease to the mating surface of the exhaust manifold.

3. Install a new gasket on the studs of the exhaust manifold.

4. Position the exhaust manifold on the cylinder head and install the retaining bolts and tab washers. Working from the center to the ends torque the retaining bolts to specifications. Lock the bolts by bending one tab of the washer over a flat on the bolt.

5. Install the dipstick and tube assembly.

6. Position the power steering pump bracket on the cylinder block and install the retaining bolts. Adjust the belt tension. Position the hoses and install the power steering hose bracket.

7. Install the automatic choke heat tube on the right exhaust manifold.

8. Connect the exhaust manifold at the muffler inlet pipe. Install the air cleaner.



**BUY IT NOW!**

**Click Here To Order**



## CRANKCASE VENTILATION OUTLET

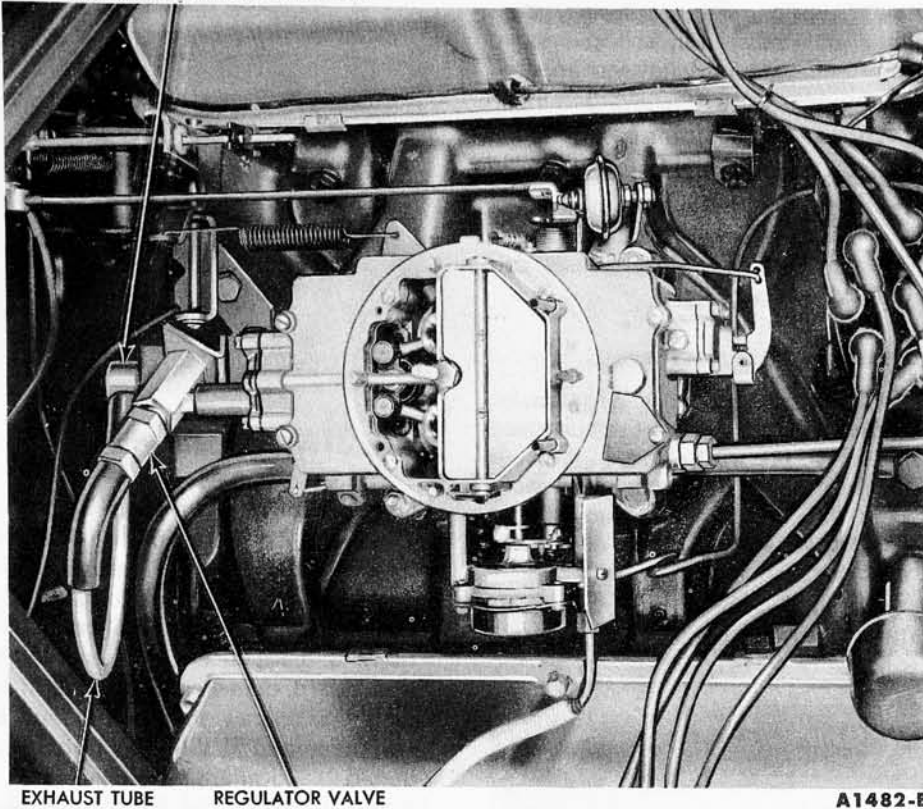


FIG. 24—Regulator Valve and Exhaust Tube

## CLEANING AND INSPECTION

Inspect the manifolds for cracks, leaks, or other defects that would make them unfit for further service.

On the right exhaust manifold, clean out the automatic choke air heat chamber (Fig. 5). Make sure the air inlet and outlet holes are completely open and the cover does not leak. Blow out the automatic choke air heat tube with compressed air.

## POSITIVE CRANKCASE VENTILATION SYSTEM

## REMOVAL

1. Disconnect the exhaust tube at the crankcase ventilation outlet and regulator valve and remove the tube. Remove the exhaust tube that connects to the spacer (Fig. 24).

2. Remove the regulator valve assembly from the Tee-fitting.

3. Remove the outlet adapter from the valve manifold.

2. Install the regulator valve in the Tee-fitting.

3. Install the exhaust tubes.

## REGULATOR VALVE DISASSEMBLY

Place the hex on the regulator valve body in a vise. Remove the connector, valve, and spring (Fig. 25).

## CLEANING

Clean the valve parts and exhaust tube in clean carburetor solvent and dry them with compressed air. Clean the rubber hose connections with a low volatility petroleum base solvent and dry with compressed air.

## REGULATOR VALVE ASSEMBLY

Position the spring and valve inside the regulator valve body. Install the regulator valve connector.

## CYLINDER HEADS AND VALVES

## CYLINDER HEAD REMOVAL

1. Remove the intake manifold, carburetor, and radiator supply tank as an assembly following the procedure under "Intake Manifold Removal."

2. Disconnect the exhaust manifolds at the muffler inlet pipes.

If the left cylinder head is to be removed, remove the ignition coil.

3. Remove the cylinder head bolts. Install the cylinder head holding fixtures (Fig. 26).

4. Lift the cylinder heads off the block. **Do not pry between the head and the block.** Remove and discard the cylinder head gasket.

## CYLINDER HEAD INSTALLATION

1. Clean the cylinder head and cylinder block gasket surfaces.

2. If the cylinder head was removed for a cylinder head gasket replacement, check the flatness of the cylinder head and block gasket surfaces (Fig. 29).

3. Apply cylinder head gasket sealer to both sides of a new gasket. Guided by the word "FRONT" on the gasket, install the gasket over the cylinder head dowels.

4. Place the cylinder head on the engine, then remove the holding fixtures.

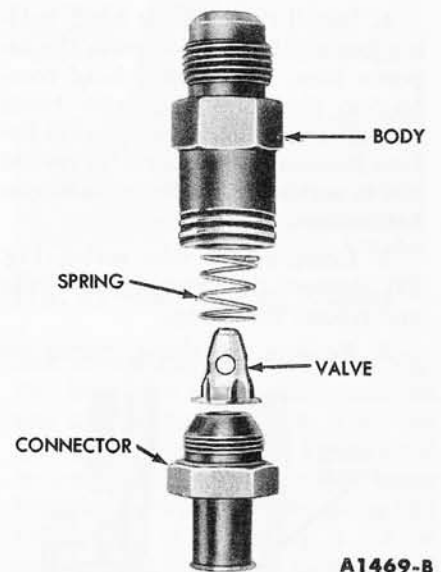


FIG. 25—Regulator Valve Assembly

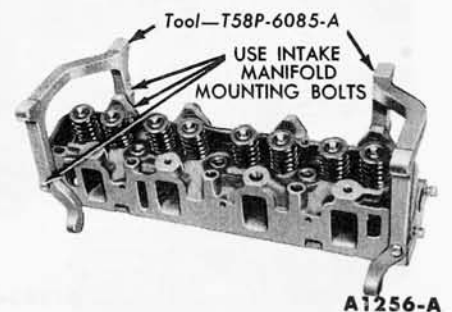


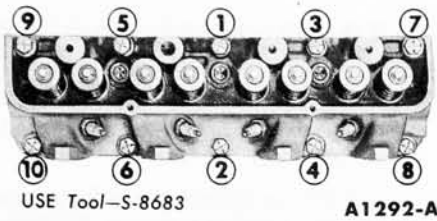
FIG. 26—Cylinder Head Holding Fixtures

**100% SATISFACTION GUARANTEED**

**BUY IT NOW!**

**Click Here To Order**

PayPal American Express Discover Novus MasterCard VISA



**FIG. 27—Cylinder Head Bolt Tightening Sequence**

5. Install the cylinder head bolts. The cylinder head bolts are tightened in three progressive steps. Torque all the bolts in sequence (Fig. 27) to 70 ft-lbs, then torque them to 80 ft-lbs, and finally to 90 ft-lbs. **After the cylinder head bolts have been torqued to specifications, the bolts should not be disturbed.**

6. Connect the exhaust manifolds to the muffler inlet pipes.

7. Install the intake manifold and related parts following the procedure under "Intake Manifold Installation."

**CYLINDER HEAD DISASSEMBLY**

1. Install the cylinder head holding fixtures (Fig. 26). Remove the deposits from the cylinder head combustion chambers and valve heads with a scraper and a wire brush before removing the valves. **Be careful not to scratch the cylinder head gasket surface.**

2. Compress the valve spring (Fig. 28). Remove the valve retainer locks and release the spring.

3. Remove the sleeve, spring re-

tainer, spring, damper spring, stem seal, and valve. Discard the valve stem seals. Identify all valve parts.

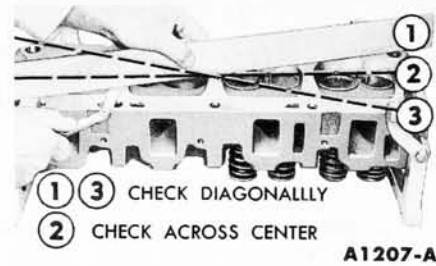
**CYLINDER HEAD CLEANING**

After the valves are removed, clean the valve guide bores with a valve guide cleaning tool. Use cleaning solvent to remove dirt, grease, and other deposits.

**CYLINDER HEAD INSPECTION**

Check the cylinder head for cracks, and the gasket surface for burrs and nicks. Replace the head if it is cracked. **Do not plane or grind more than 0.010 inch from the cylinder head gasket surface.** Remove all burrs and scratches with an oil stone.

**Cylinder Head Flatness.** Check the flatness of the cylinder head gasket surface (Fig. 29).



**FIG. 29—Cylinder Head Flatness**

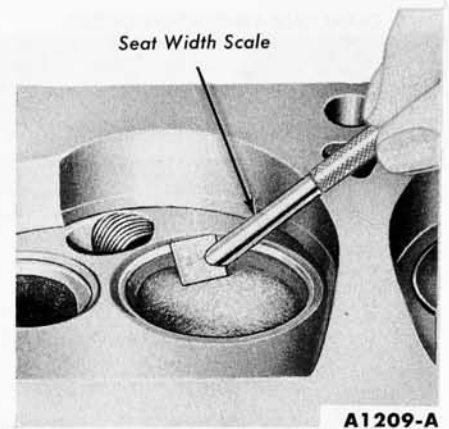
**Valve Seat Runout.** Check the valve seat runout with an accurate gauge (Fig. 30). Follow the instructions of the gauge manufacturer. If the runout exceeds the wear limit, reface the valve and valve seat.

**Valve Seat Width.** Measure the valve seat width (Fig. 31).

**Reaming Valve Guides.** If it be-



**FIG. 30—Valve Seat Runout**

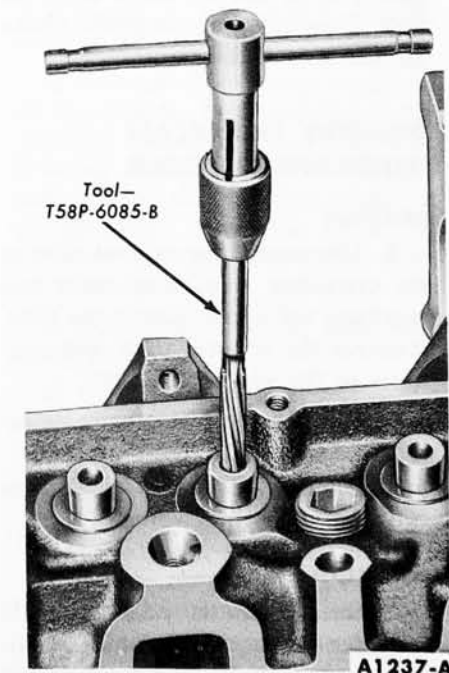


**FIG. 31—Valve Seat Width**

comes necessary to ream a valve guide (Fig. 32) to install a valve with an oversize stem, a reaming kit is available which contains the following reamer and pilot combinations: a 0.003-inch OS reamer with a standard diameter pilot, a 0.015-inch OS reamer with a 0.003-inch OS pilot, and a 0.030-inch reamer with a 0.015-inch OS pilot.

When going from a standard size valve to an oversize valve, always use the reamers in sequence. **Always reface the valve seat after the valve guide has been reamed.**

**Refacing Valve Seats.** Refacing of the valve seats should be closely coordinated with the refacing of the valve face so that the finished seat will match the valve face and be centered. This is important so that the valve and seat will have a good compres-



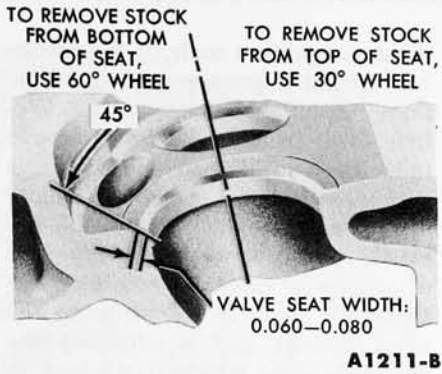
**FIG. 32—Reaming Valve Guides**

**100% SATISFACTION GUARANTEED**

**BUY IT NOW!**

**Click Here To Order**

PayPal, American Express, Discover, MasterCard, VISA



**FIG. 33—Intake Valve Seat Refacing**

sion tight fit. Be sure that the refacer grinding wheels are properly dressed.

Grind the valve seats to a true 45° angle (Fig. 33). Remove only enough stock to clean up pits, grooves, or to correct the valve seat runout. After the seat has been refaced, measure the seat width (Fig. 31). Narrow the seat, if necessary, to bring it within limits.

If the valve seat width exceeds the maximum limit, remove enough stock from the top edge and/or bottom edge of the seat to reduce the width to specifications (Fig. 33).

Use a 60° angle grinding wheel to remove stock from the bottom of the seat (raise the seat) and use a 30° angle wheel to remove stock from the top of the seat (lower the seat).

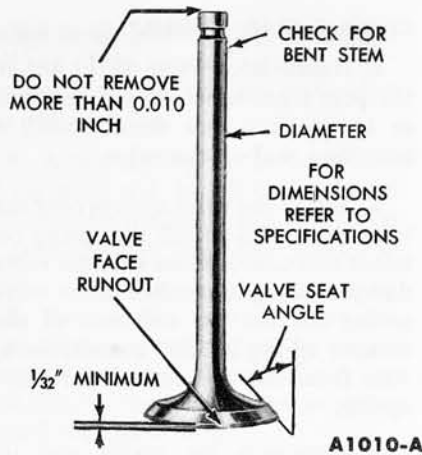
The finished valve seat should contact the approximate center of the valve face. It is good practice to determine where the valve seat contacts the face. To do this, coat the seat with Prussian blue, then set the valve in place. Rotate the valve with light pressure. If the blue is transferred to the center of the valve face, the contact is satisfactory. If the blue is transferred to the top edge of the valve face, lower the valve seat. If the blue is transferred to the bottom edge of the valve face, raise the valve seat.

**VALVES**

**Cleaning.** Remove all deposits from the valve with a fine wire brush or buffing wheel.

**INSPECTION**

The critical inspection points and tolerances of the valves are illustrated

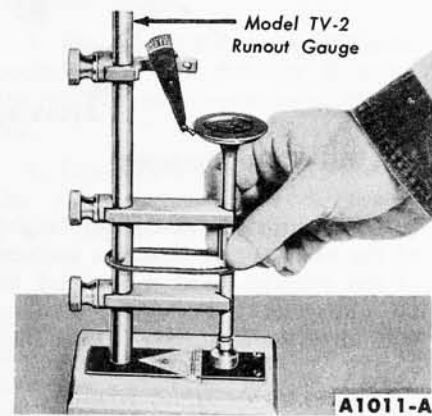


**FIG. 34—Critical Valve Tolerances**

or scores. Check the valve head for signs of burning, erosion, warpage, and cracking. Defects, such as minor pits, grooves, etc., may be removed. Discard valves that are severely damaged.

Inspect the valve springs, valve spring retainers, locks, and sleeves for defects. Discard any visually defective parts.

**Valve Face Runout.** Check the valve face runout (Fig. 35). It should not exceed the wear limit.

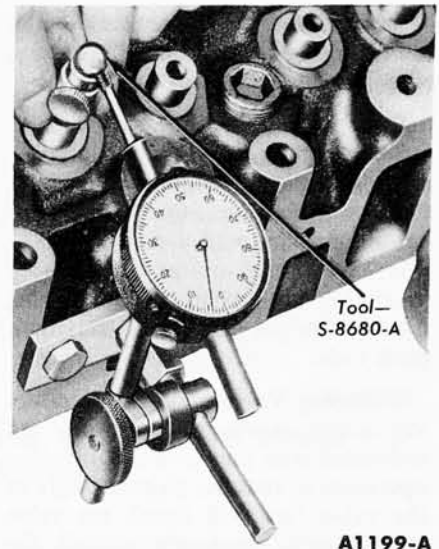


**FIG. 35—Valve Face Runout**

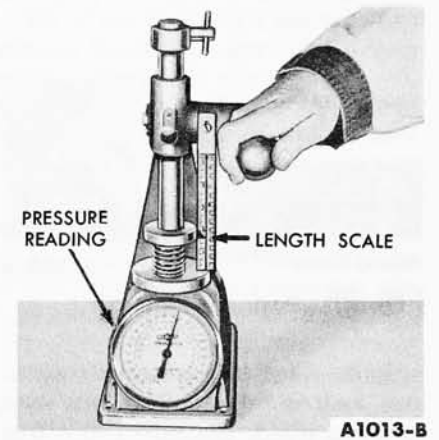
**Valve Stem Clearance.** Check the valve stem to valve guide clearance of each valve in its respective valve guide with the tool shown in Fig. 36 or its equivalent. Use a flat-end indicator point.

**Valve Spring Pressure.** Check the spring for proper pressure (Fig. 37). Do not remove the damper spring when checking the pressure. Weak valve springs cause poor engine performance; therefore, if the pressure of any spring exceeds the wear limit, replace the spring.

**Valve Spring Squareness.** Check each spring for squareness, using a

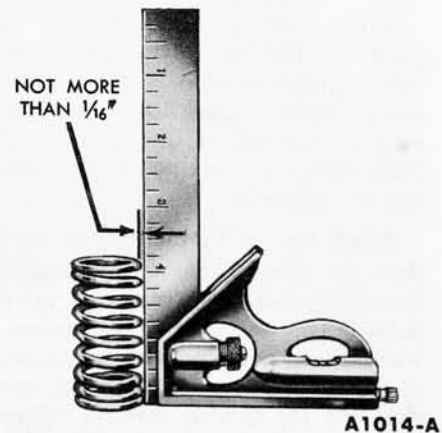


**FIG. 36—Valve Stem Clearance**



**FIG. 37—Valve Spring Pressure**

steel square and a surface plate (Fig. 38). Stand the spring and square on end on the surface plate. Slide the spring up to the square. Revolve the spring slowly and observe the space between the top coil of the spring and the square. If the spring is out of square more than 1/16 inch, replace it.



**FIG. 38—Valve Spring Squareness**

**100% SATISFACTION GUARANTEED**

**BUY IT NOW!**

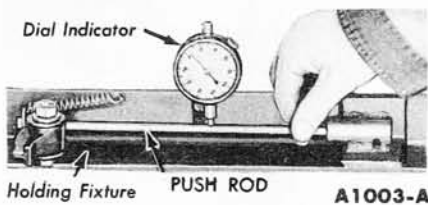
**Click Here To Order**

PayPal, American Express, Discover, MasterCard, VISA

**Valve Push Rods.** Check the ends of the push rods for nicks, grooves, roughness, or excessive wear.

The push rods can be visually checked for straightness while they are installed in the engine by rotating them with the valve closed. They also can be checked with a dial indicator (Fig. 39). If the runout exceeds the maximum limit at any point, discard the rod. **Do not attempt to straighten push rods.**

**Refacing Valves.** The valve refacing operation should be closely coordinated with the valve seat refacing operation so that the finished angle of the valve face will match the valve seat. This is important so that the valve and seat will have a good compression tight fit. Be sure that the refacer grinding wheels are properly dressed.



**FIG. 39—Push Rod Runout**

If the valve face runout is excessive and/or to remove pits and grooves, reface the valves to a true 44° angle. Remove only enough stock to correct the runout or to clean up the pits and grooves. If the edge of the valve head is less than 1/32 inch after grinding, replace the valve as the valve will run too hot in the engine.

Remove all grooves or score marks from the end of the valve stem, then chamfer as necessary. Do not remove more than 0.010 inch from the stem.

After refacing the valves, it is good practice to lightly lap in the valves with a medium grade lapping compound to match the seats. Be sure to remove all the compound from the valve and seat after the lapping operation.

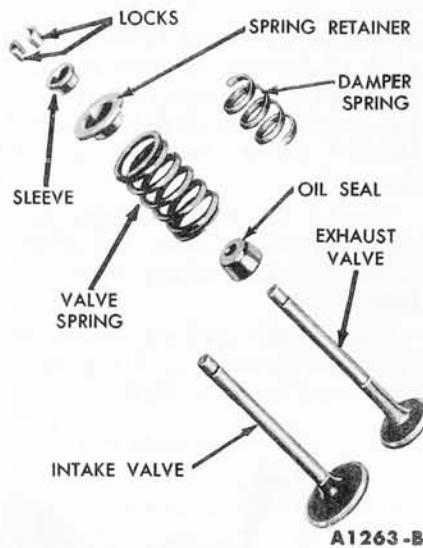
**Select Fitting Valves.** If the valve stem to valve guide clearance exceeds the wear limit, ream the valve

#### CYLINDER HEAD ASSEMBLY

1. Install each valve (Fig. 40) in the port from which it was removed or to which it was fitted. Install a new stem seal on the valve.

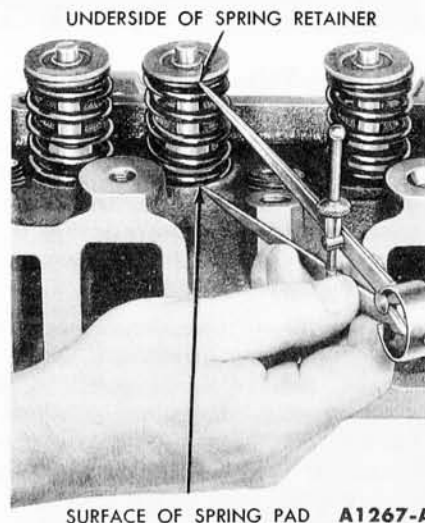
2. Install the valve springs over the valve, and then install the spring retainer and sleeve. **Make sure the valve damper spring is installed in the valve spring so that the coil end of the damper spring is 135° counterclockwise from the coil end of the valve spring.**

3. Compress the spring and install the retainer locks (Fig. 28).



**FIG. 40—Valve Assembly**

4. Measure the assembled height of the valve spring from the surface of the cylinder head spring pad to the underside of the spring retainer with dividers (Fig. 41). Check the



**FIG. 41—Valve Spring Assembled Height**

dividers against a scale. If the assembled height is greater than specifications, install the necessary 0.030-inch thick spacer(s) between the cylinder head spring pad and the valve spring to bring the assembled height to the recommended height. **Do not install spacers unless necessary. Use of spacers in excess of recommendations will result in overstressing the valve springs and overloading the camshaft lobes which could lead to spring breakage and worn camshaft lobes.**

#### VALVE STEM SEAL REPLACEMENT

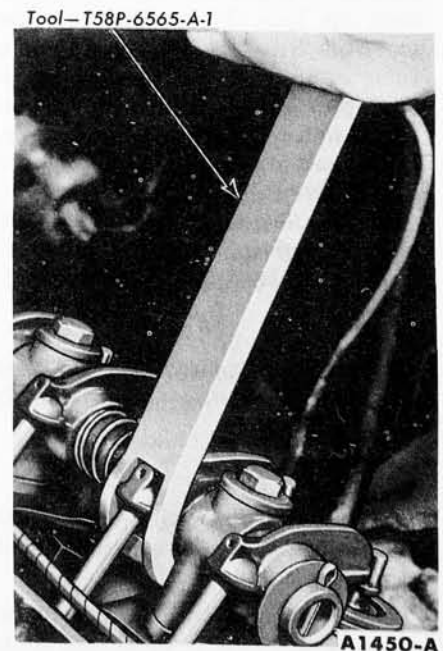
1. Remove the air cleaner and the valve rocker arm cover. Remove the applicable spark plug.

2. Crank the engine until the applicable piston is on TDC after the compression stroke. Be sure that both valves are closed. **Be sure that the piston is on TDC to prevent the crankshaft from turning when the air is applied.**

3. Install an air line with an adapter in the spark plug hole and turn on the air supply.

4. Position the hydraulic lifter compressor tool on the applicable rocker arm and slowly apply pressure to bleed down the hydraulic lifter until the plunger is completely bottomed (Fig. 42). Remove the push rod.

5. Push the rocker arm to one side and secure it in this position



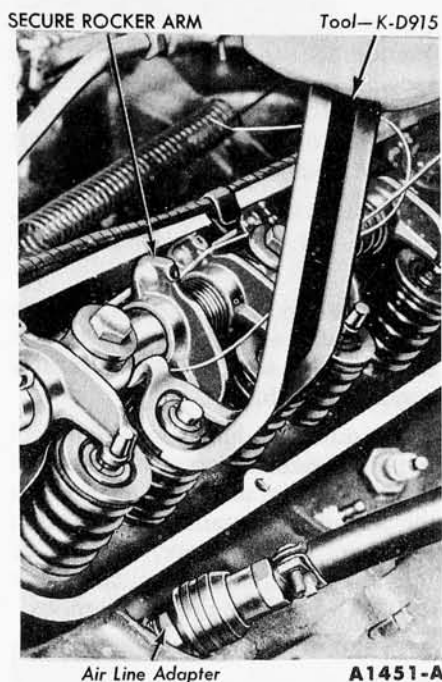
**FIG. 42—Bleeding Down Hydraulic Valve Lifter**

**100% SATISFACTION GUARANTEED**

**BUY IT NOW!**

**Click Here To Order**

PayPal | American Express | Discover | MasterCard | VISA



**FIG. 43—Compressing Valve Spring**

(Fig. 43). Using the valve spring compression tool shown in Fig. 43, compress the valve spring. Remove the valve spring retainer locks, the sleeve, spring retainer, and the valve spring. If an end rocker arm is to be worked on, it will be necessary to remove the rocker arm from the shaft.

6. Remove the valve stem seal (Fig. 44).

7. Install a new valve stem seal. Place the spring in position over the valve. Install the spring retainer and sleeve. Compress the valve spring and install the valve spring retainer locks.

**Be sure the damper spring is in-**

stalled in the valve spring so that the coil end of the damper spring is 135° counterclockwise from the coil end of the valve spring.

8. Apply Lubriplate to both ends of the push rod. Install the push rod making sure the lower end of the rod is positioned in the lifter push rod cup.

9. Remove the wire securing the valve rocker arm and slide the rocker arm into position. Turn off the air and remove the air line and adapter. Install the spark plug.

10. Install the valve rocker arm cover and connect the spark plug wires. Install the air cleaner.

### CYLINDER FRONT COVER AND TIMING CHAIN

#### REMOVAL

1. Drain the cooling system and the crankcase. Remove the air cleaner. Disconnect the battery ground cable.

2. Disconnect the radiator upper hose at the radiator supply tank. Disconnect the radiator lower hose at the water pump.

3. Disconnect the transmission oil cooler lines at the radiator. Remove the radiator and support as an assembly.

4. Disconnect the heater hose at the water pump. Slide the water pump by-pass hose clamp toward the engine.

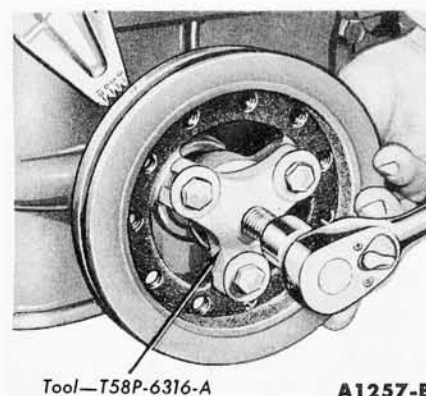
5. Disconnect the power steering pump bracket from the water pump and remove the drive belt. Wire the power steering pump assembly to the left side of the car in a position that will prevent the oil from draining out.

On a car with an air conditioner, remove the compressor drive belt.

6. Loosen the generator mounting bolts at the generator. Remove the drive belt. Remove the generator support bolt at the water pump. Remove the water pump, drive belt adjusting arm, pulley, and fan as an assembly. Remove the power steering pulley from the crankshaft damper.

7. Remove the cap screw and washer from the end of the crankshaft. Install the puller on the crankshaft damper (Fig. 45) and remove the damper.

8. Disconnect the carburetor fuel inlet line at the fuel pump.



**FIG. 45—Crankshaft Damper Removal**

9. Remove the fuel pump retaining bolts and lay the pump to one side with the flexible fuel line still attached.

10. If the crankshaft sleeve is not stepped down (the same OD on both ends), remove it as shown in Fig. 46. If the sleeve is stepped down, remove it with a three jawed puller (tool 7675-N).

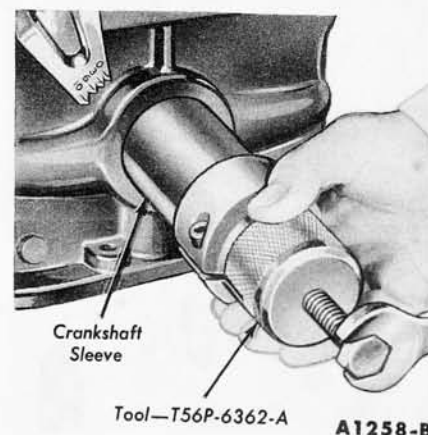
11. Remove the screws fastening the cylinder front cover to the block. Remove the cylinder front cover. On a car with an air conditioner, the compressor brackets are retained by cylinder front cover screws.

12. Discard the cylinder front cover gasket. Remove the oil slinger.

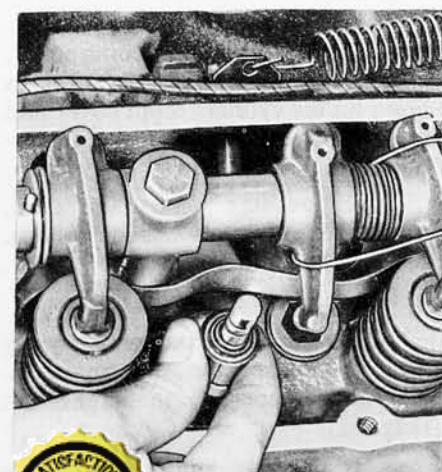
13. Rotate the crankshaft in a clockwise direction (as viewed from the front) to take up the slack on the left side of the chain.

14. Establish a reference point on the block and measure from this point to the chain (Fig. 47).

15. Rotate the crankshaft in the opposite direction to take up the slack on the right side of the chain. Force the left side of the chain



**FIG. 46—Crankshaft Sleeve Removal**

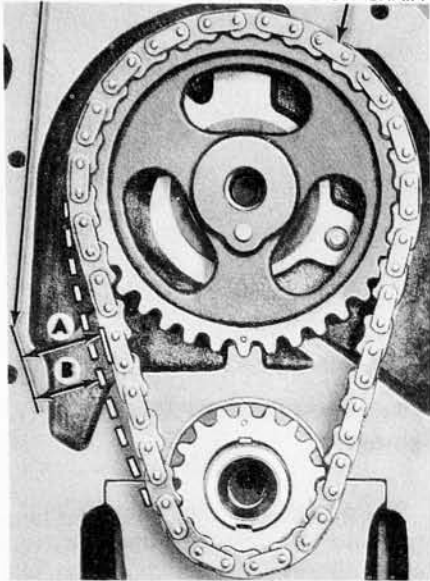


**100% SATISFACTION GUARANTEED**

**BUY IT NOW!**

**Click Here To Order**

REFERENCE POINT RIGHT SIDE OF CHAIN



TAKE UP SLACK ON LEFT SIDE, ESTABLISH REFERENCE POINT. MEASURE DISTANCE A. TAKE UP SLACK ON RIGHT SIDE. FORCE LEFT SIDE OUT. MEASURE DISTANCE B. DEFLECTION IS A MINUS B. A1284-A

FIG. 47—Timing Chain Deflection

out with the fingers and measure the distance between the reference point and the chain. The deflection is the difference between the two measurements.

If the deflection exceeds 1/2 inch, replace the timing chain and/or sprockets.

16. Crank the engine until the timing marks on the sprockets are positioned as shown in Fig. 48.

17. Remove the camshaft thrust

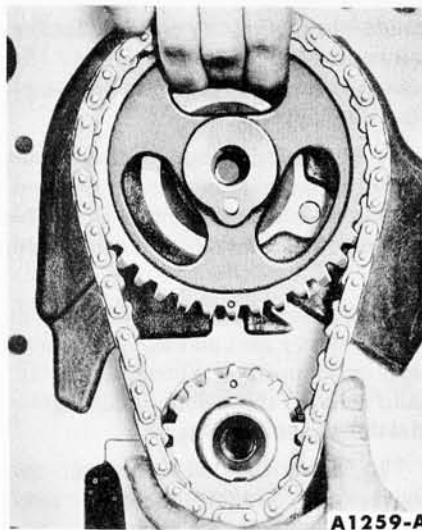
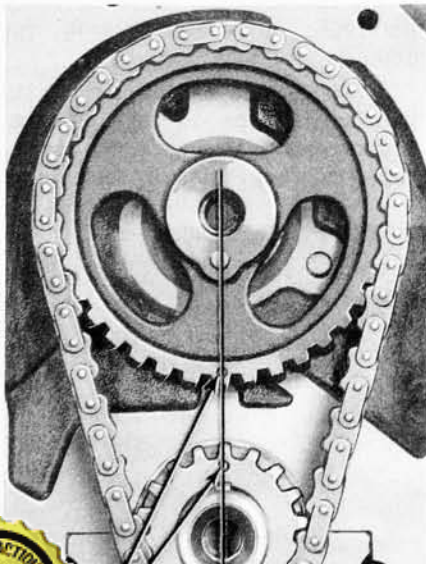


FIG. 49—Timing Chain Removal or Installation

button and spring, the sprocket cap screw, the thrust button spring retainer, and the fuel pump eccentric.

18. Slide both sprockets and the timing chain forward, and remove the sprockets and timing chain as an assembly (Fig. 49).

19. Remove the oil pan and oil pump screen, following the procedure under "Oil Pan Removal."

INSTALLATION

1. Position the sprockets and timing chain on the camshaft and crankshaft (Fig. 49). Be sure the timing marks on the sprockets are positioned as shown in Fig. 48.

2. Install the fuel pump eccentric, the camshaft sprocket cap screw, and

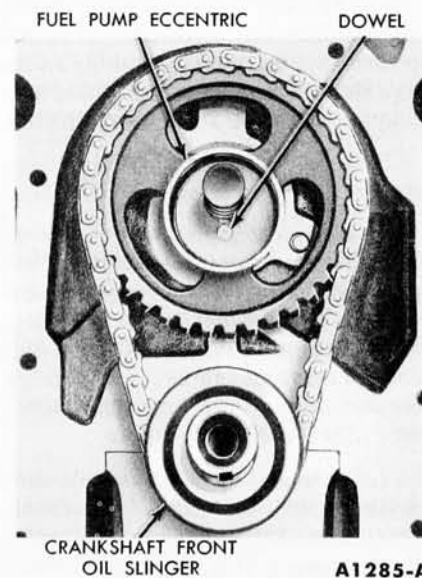


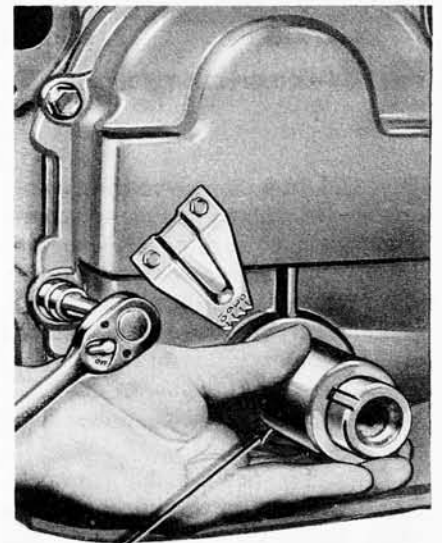
FIG. 50—Fuel Pump Eccentric and Front Oil Slinger Installed

the thrust button spring retainer. Torque the sprocket cap screw to specifications. Install the camshaft thrust button spring and thrust button (Fig. 50). Install the crankshaft front oil slinger.

3. Clean the cylinder front cover, oil pan, and the block gasket surfaces.

4. Coat the gasket surface of the block and cover and the cover bolt threads with sealer. Position a new gasket on the block.

5. Install the alignment pilot tool on the cylinder front cover so that the keyway in the pilot aligns with the key in the crankshaft. Position the cover and pilot over the end of the crankshaft and against the block (Fig. 51). Install the retaining screws.



Tool—T61P-6019-B A1287-B

FIG. 51—Cylinder Front Cover Alignment

On a car with an air conditioner, position the compressor bracket in place on the cylinder front cover and install the retaining screws finger-tight.

While pushing in on the pilot, torque the screws to specifications. Remove the pilot.

6. Install the crankshaft sleeve.

7. Line up the damper keyway with the key on the crankshaft. Install the damper on the crankshaft (Fig. 52).

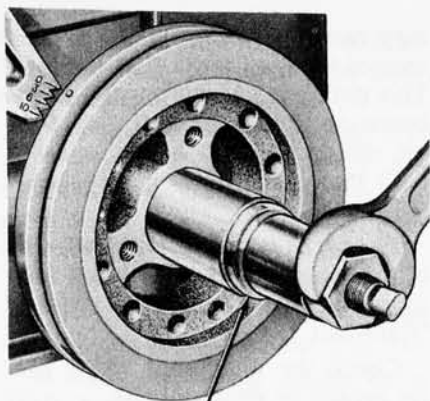
8. Install the damper cap screw and washer, and torque the screw to specifications.

9. Install the power steering pump pulley on the damper. Torque the screws to specifications.

**100% SATISFACTION GUARANTEED**

**BUY IT NOW!**

**Click Here To Order**



Tool—T52L-6306-AEE A1289-B

### FIG. 52—Crankshaft Damper Installation

10. Clean the oil pan and the oil pump screen. Install the oil pump screen and oil pan.

11. Clean the water pump gasket surfaces. Coat new gaskets with sealer and position the gaskets on the block. Install the water pump, pulley, fan, and generator adjusting arm as an assembly.

12. Install and adjust the generator drive belt(s).

On a car with an air conditioner, install and adjust the drive belt.

13. Install the power steering pump drive belt and attach the pump bracket to the water pump. Adjust the drive belt tension.

14. Install the fuel pump using a new gasket.

15. Connect the carburetor fuel inlet line. Connect the heater hoses. Slide the water pump by-pass tube clamp forward on the tube.

16. Install the radiator and support as an assembly. Connect the radiator lower hose at the water pump and the radiator upper hose at the radiator supply tank. Connect the battery ground cable. Connect the transmission oil cooler lines.

17. Fill and bleed the cooling system. Fill the crankcase with the proper grade and quantity of engine oil. Connect the heater hose to the intake manifold.

18. Operate the engine at fast idle and check for coolant and oil leaks. Adjust the ignition timing. Install the air cleaner.

damaged teeth. Replace all the components of the timing chain and sprocket assembly if any one item needs replacement.

#### FRONT OIL SEAL REPLACEMENT

It is good practice to replace the oil seal each time the cylinder front cover is removed.

1. Drive out the old seal with a pin punch. Clean out the recess in the cover.

2. Coat a new seal with grease, then install the seal (Fig. 53). Drive the seal in until it is fully seated in the recess. Check the seal after installation to be sure the spring is properly positioned in the seal.

#### CAMSHAFT

The camshaft and related parts are shown in Fig. 54.

#### REMOVAL

1. Remove the cylinder front cov-

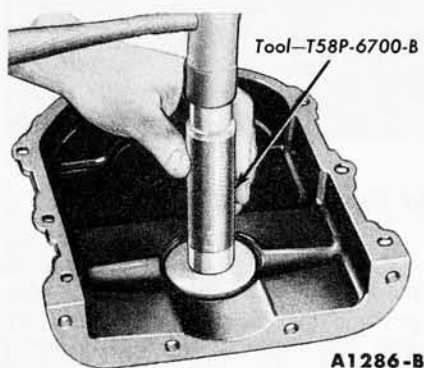


FIG. 53—Oil Seal Installation

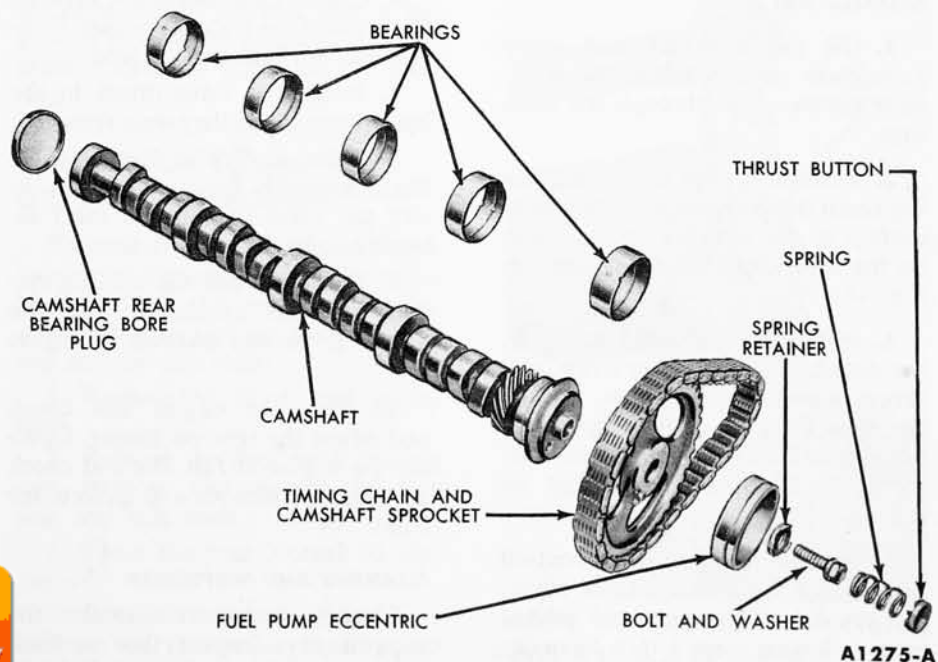


FIG. 54—Camshaft and Related Parts

er and the timing chain and sprockets following steps 1 thru 18 under "Cylinder Front Cover and Timing Chain Removal."

2. Disconnect the spark plug wires at the spark plugs and remove the wires from the ignition harness brackets on the valve rocker arm covers. Disconnect the coil high tension lead at the coil. Remove the distributor cap and spark plug wire assembly. Disconnect the distributor vacuum line at the distributor. Remove the distributor hold down bolt and clamp and remove the distributor.

3. Remove the valve rocker arm covers. Refer to "Valve Rocker Arm Shaft Assembly Removal" and remove the valve rocker arm shaft assemblies by following steps 4 and 5.

4. Remove the valve push rods in sequence and place them in a rack so that they can be installed in their original positions.

5. Position an inspection light through a push rod opening and into the valve push rod valley (Fig. 55). Remove the valve lifters with a magnet through the push rod openings. In some cases, it will be necessary to transfer the lifter over to an adjoining push rod opening in order to remove it. Place the lifters in a rack so that they can be installed in their original positions.

6. Remove the oil pan and oil pump screen by following the pro-

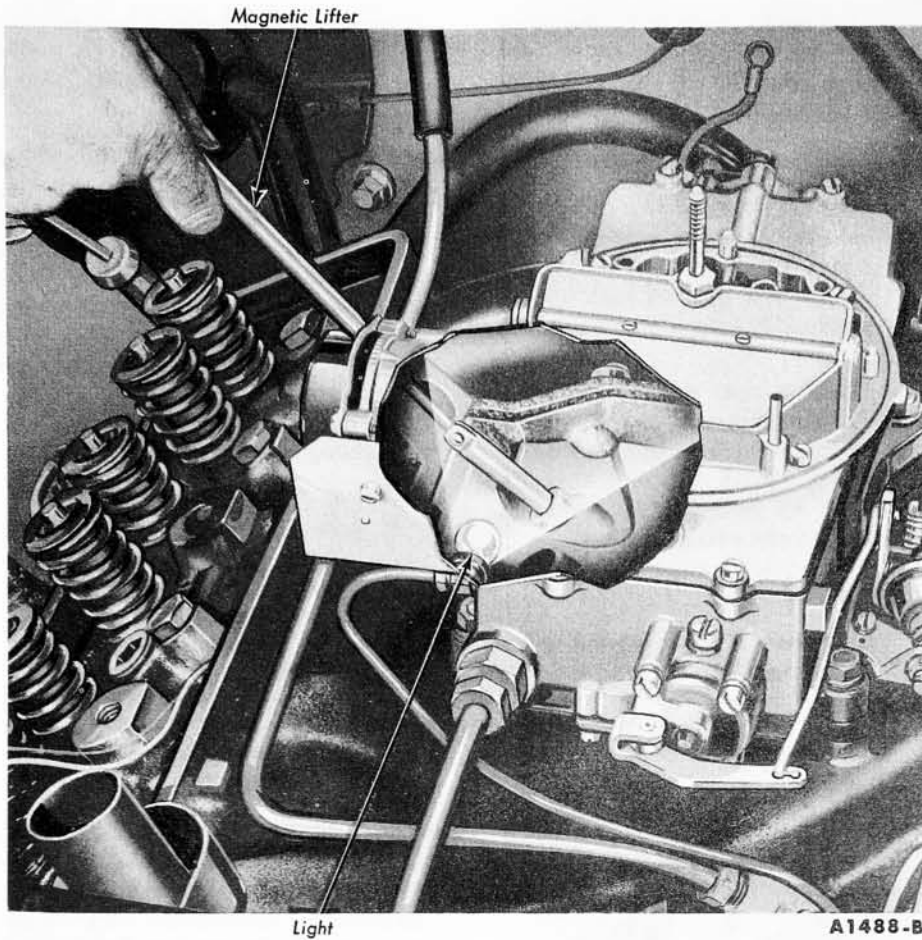
**100% SATISFACTION GUARANTEED**

**BUY IT NOW!**

**Click Here To Order**

th  
th  
spr

PayPal  
Cards  
DISCOVER  
MasterCard  
VISA



**FIG. 55—Valve Lifter Replacement—Intake Manifold Installed**

cedure under “Oil Pan Removal.”

7. Carefully remove the camshaft by pulling it toward the front of the engine. Use caution to avoid damaging the camshaft bearings.

#### INSTALLATION

1. Oil the camshaft and apply Lubriplate to the lobes. Carefully slide the camshaft through the bearings.

2. Position the sprockets and timing chain on the camshaft and crankshaft (Fig. 49) with the timing marks on the sprockets aligned as shown in Fig. 48.

3. Install the fuel pump eccentric, the camshaft sprocket cap screw, and thrust button spring retainer. Torque the sprocket cap screw to specifications. Install the camshaft thrust button (Fig. 50). Install the front oil finger.

4. Replace the crankshaft front oil

5. With No. 1 piston on TDC at the end of the compression stroke, position the distributor in the block with the rotor at the No. 1 firing position and the points open. Install the hold down clamp.

6. Connect the distributor vacuum line. Install the distributor cap. Connect the coil high tension lead.

7. Install the valve lifters in the bores from which they were removed.

8. Refer to “Valve Rocker Arm Shaft Assembly Installation” and install the valve rocker arm shaft assembly following steps 1 thru 9.

9. Fill and bleed the cooling system. Fill the crankcase with the proper grade and quantity of engine oil.

10. Start the engine and check and adjust the ignition timing. Operate the engine at fast idle and check all hose connections and gaskets for leaks.

#### CLEANING AND INSPECTION

Clean the camshaft in solvent and wipe it dry. Inspect the camshaft lobes for scoring, and signs of abnormal wear. Lobe wear characteristics

may result in pitting in the general area of the nose portion of the lobe. This pitting is not detrimental to the operation of the camshaft, therefore, the camshaft should not be replaced until the lobe lift loss has exceeded 0.005 inch.

The lift of camshaft lobes can only be accurately checked with the camshaft installed in the engine. Refer to “Camshaft Lobe Lift.”

Check the distributor drive gear for broken or chipped teeth.

Remove light scuffs, scores, or nicks from the camshaft machined surfaces with a smooth oilstone.

#### CAMSHAFT REAR BEARING BORE PLUG REPLACEMENT

1. Remove the transmission and converter housing by following the procedure in Part 5-4.

2. Remove the flywheel retaining bolts and remove the flywheel.

3. Drill a ½-inch hole in the camshaft rear bearing bore plug and use tool T-7600-E to remove the plug.

4. Clean out the plug bore recess thoroughly.

5. Coat the flange of a new plug with water resistant sealer and install it with the flange facing out (Fig. 83).

6. Install the flywheel.

7. Install the transmission and converter housing by following the procedure in Part 5-4.

#### HYDRAULIC VALVE LIFTER REPLACEMENT

The following procedure is applicable for removing one or all of the valve lifters. This procedure can not be used if the valve lifters are stuck in their bores by excessive varnish, etc. In this case it will be necessary to remove the intake manifold. After the intake manifold has been removed, remove the valve lifters.

1. Refer to “Valve Rocker Arm Shaft Assembly Removal” and remove the valve rocker arm covers and the valve rocker arm shaft assemblies by following steps 1 thru 5.

2. Position an inspection light through a push rod opening and into the valve push rod valley (Fig. 55). Remove the valve lifters with a magnet through the push rod openings. In some cases, it will be necessary to transfer the lifter over to an adjoining push rod opening in order to re-

**100% SATISFACTION GUARANTEED**

**BUY IT NOW!**

**Click Here To Order**

PayPal   American Express   Discover   MasterCard   VISA

move it. Place the lifters in a rack so that they can be installed in their original positions.

The internal parts of each hydraulic valve lifter assembly are matched sets. Do not intermix the parts. Keep the assemblies intact until they are to be cleaned.

3. Install the new (or cleaned) hydraulic valve lifters through the push rod openings with a magnet (Fig. 55).

4. Refer to "Valve Rocker Arm Shaft Assembly Installation" and install the valve rocker arm shaft assemblies and the covers by following steps 1 thru 9.

#### CLEANING AND INSPECTION

The lifter assemblies should be kept in proper sequence so that they can be installed in their original position. Inspect and test each lifter separately so as not to intermix the internal parts. If any part of the lifter assembly needs replacing, replace the entire assembly.

Thoroughly clean all the parts in clean solvent and wipe them with a clean, lint-free cloth.

Inspect the parts and discard the entire lifter assembly if any part shows signs of pitting, scoring, galling, or evidence of non-rotation. Replace the entire assembly if the plunger is not free in the body. The plunger should drop to the bottom of the body by its own weight.

Assemble the lifter assembly and check the assembly for freeness of operation by pressing down on the push rod cup. The lifter can also be checked with a hydraulic valve lifter tester to test the leak-down rate. Follow the instructions of the test unit manufacturer.

#### DISASSEMBLY

Each valve lifter is a matched assembly. If the parts of one lifter are inter-mixed with those of another, improper valve operation may result. Disassemble and assemble each lifter separately. Keep the lifter assemblies in proper sequence so that they can be installed in their original bores.

1. Grasp the lock ring with needle-nose pliers to release it from the lifter body. If necessary, depress the

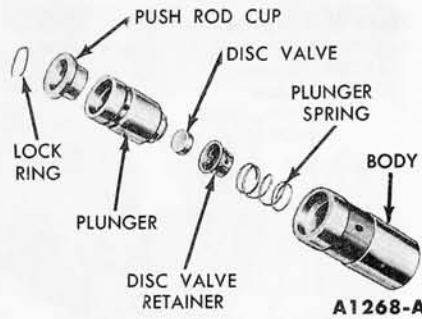


FIG. 56—Typical Hydraulic Valve Lifter Assembly

carefully prying up on it with a screw driver. Remove the disc valve and spring.

#### ASSEMBLY

A typical hydraulic valve lifter is shown in Fig. 56.

1. Place the plunger upside down on a clean work bench.
2. Place the disc valve in position over the oil hole on the bottom of the plunger. Set the disc valve spring on top of the disc.
3. Position the disc valve retainer over the disc and spring and push the retainer down into place on the plunger.
4. Place the plunger spring, and then the plunger (open end up) into the lifter body.
5. Place the push rod seat in the plunger.
6. Depress the plunger, and position the closed end of the lock ring in the groove of the lifter body. With the plunger still depressed, position the open ends of the lock ring in the groove. Release the plunger, then depress it again to fully seat the lock ring.

#### CRANKSHAFT LOWER REAR OIL SEAL REPLACEMENT

The upper oil seal in the block cannot be replaced with the crankshaft installed. To replace the lower rear oil seal in the rear main bearing cap and the side seals:

1. Remove the oil pan and related parts.
2. Remove the rear main bearing cap. Remove and discard the rear seal and side seals.
3. Clean the rear journal oil seal groove.
4. Install a new rear journal oil seal in the rear main bearing cap (Fig. 57). After installation, cut the ends of the seals flush.

5. Apply a thin coating of oil resistant sealer to the rear main bearing cap at the rear of the top mating surface (Fig. 57). Do not apply sealer to the area forward of the side seal groove. Install the rear main bearing cap. Torque the cap bolts to specifications.

6. Dip the side seals in light engine oil, then immediately install them in the grooves. Do not use sealer on the side seals. The seals are designed to expand when dipped in oil. Using sealer may retard this expansion. It may be necessary to tap the seals into place for the last 1/2 inch of travel. Do not cut the seal projecting ends.

7. Check the retainer side seals for leaks by squirting a few drops of oil into the parting lines between the rear main bearing cap and the cylinder block from the outside. Blow compressed air against the seals from the inside of the block. If air bubbles appear in the oil, it indicates possible oil leakage. This test should not be performed on newly installed seals until sufficient time has been allowed for the seals to expand into the seal grooves.

8. Install the oil pan and related parts.

9. Fill the crankcase. Start the engine and check for oil pressure. Operate the engine at fast idle and check for oil leaks.

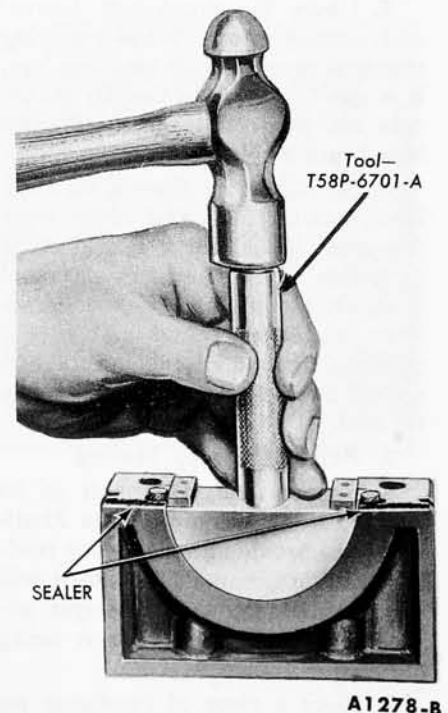


FIG. 57—Seal To Rear Bearing Cap Installation

**100% SATISFACTION GUARANTEED**

**BUY IT NOW!**

**Click Here To Order**

PayPal, American Express, Discover, MasterCard, VISA

## MAIN AND CONNECTING ROD BEARING REPLACEMENT

The main and connecting rod bearing inserts are selective fit. **Do not file or lap bearing caps or use shims to obtain the proper bearing clearance.**

Selective fit bearings are available for service in standard sizes only. Standard bearings are divided into two sizes and are identified by a daub of red or blue paint. Refer to the Parts Catalog for the available sizes. **Red marked bearings increase the clearance; blue marked bearings decrease the clearance.** Undersized bearings, which are not selective fit, are available for use on journals that have been refinished.

### MAIN BEARING REPLACEMENT

1. Drain the crankcase. Remove the oil level dipstick. Remove the oil pan and oil pump. Remove the spark plugs to allow easy rotation of the crankshaft.

2. Replace one bearing at a time leaving the other bearing securely fastened. Remove the main bearing cap to which new bearings are to be installed.

3. Insert the upper bearing removal tool (tool 6331) in the oil hole in the crankshaft.

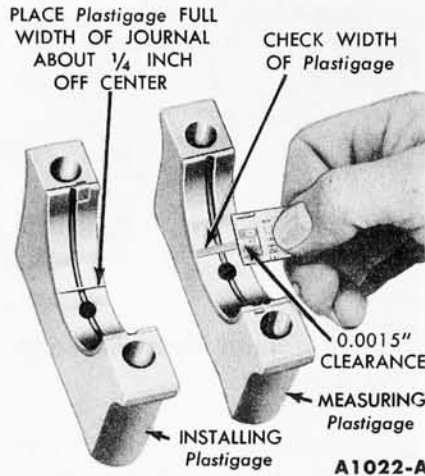
4. Rotate the crankshaft in the direction of engine rotation to force the bearing out of the block.

5. Clean the crankshaft journal and bearing inserts. **When replacing standard bearings with new bearings, it is good practice to first try to obtain the proper clearance with two blue bearing halves.**

6. To install the upper main bearing, place the plain end of the bearing over the shaft on the locking tang side of the block. Using tool 6331 in the oil hole in the crankshaft, rotate the crankshaft in the opposite direction of engine rotation until the bearing seats itself. Remove the tool.

7. Replace the cap bearing.

8. Support the crankshaft so its weight will not compress the Plastigage and provide an erroneous reading. Position a small jack so it will



**FIG. 58—Installing and Measuring Plastigage—Engine In Chassis**

10. Install the cap and torque the bolts to specifications. **Do not turn the crankshaft while the Plastigage is in place. When checking the width of the Plastigage, check at the widest point in order to get the minimum clearance. Check at the narrowest point in order to get the maximum clearance. The difference between the two readings is the taper.**

If the clearance is less than the specified limits, try two red bearing halves or a combination of red and blue depending upon the condition. If the standard bearings do not bring the clearance within the desired limits, refinish the crankshaft journal, then install undersize bearings.

11. After the bearing has been checked and found to be satisfactory, apply a light coat of engine oil to the journal and bearings, then install the bearing cap. Torque the cap bolts to specifications.

12. Repeat the procedure for the remaining bearings that require replacement.

13. If the rear main bearing is replaced, replace the lower oil seal in the rear main bearing cap and the side seals and check the side seals for leaks by following steps 3 thru 7 under "Crankshaft Lower Rear Oil Seal Replacement."

14. Disassemble, clean, and assemble the oil pump.

15. Install the oil pump and oil pan. Install the oil level dipstick. Fill the crankcase with the proper amount and viscosity oil. Install the spark plugs.

16. Operate the engine and check for oil leaks.

### CONNECTING ROD BEARING REPLACEMENT

1. Follow step 1 under "Main Bearing Replacement."

2. Turn the crankshaft until the connecting rod to which new bearings are to be fitted is down.

3. Remove the connecting rod cap. Push the connecting rod up into the cylinder and remove the bearing insert from the rod and cap.

4. Follow step 5 under "Main Bearing Replacement."

5. Install the new bearings in the connecting rod and cap. Pull the connecting rod assembly down firmly on the crankshaft journal.

6. Place a piece of Plastigage on the lower bearing surface, the full width of the cap and about 1/4 inch off center.

7. Install the cap and torque the connecting rod nuts to specifications. **Do not turn the crankshaft while the Plastigage is in place.**

8. Remove the cap. Using the Plastigage scale, check the width of the Plastigage by following step 11 under "Main Bearing Replacement."

9. After the bearing clearance has been checked and found to be satisfactory, apply a light coat of engine oil to the journal and bearings. Install the connecting rod cap.

10. Repeat the procedure for the remaining connecting rods that require new bearings.

11. Follow steps 14, 15, and 16 under "Main Bearing Replacement."

### CLEANING AND INSPECTION

Clean the bearing inserts and caps thoroughly. Inspect each bearing carefully. Bearings that have a scored, chipped, or worn surface should be replaced. Typical examples of bearing failures and their causes are shown in Fig. 59. Check the clearance of bearings that appear to be satisfactory with Plastigage. Fit new bearings following the recommended procedure. The copper lead bearing base may be visible through the bearing overlay. This does not mean that the bearing is worn. Do not replace the bearing if the bearing clearance is within recommended limits.

### PISTON AND CONNECTING ROD ASSEMBLY

#### REMOVAL

1. Drain the cooling system and the crankcase. Remove the intake

**100% SATISFACTION GUARANTEED**

**BUY IT NOW!**

**Click Here To Order**

PayPal | American Express | Discover | MasterCard | VISA

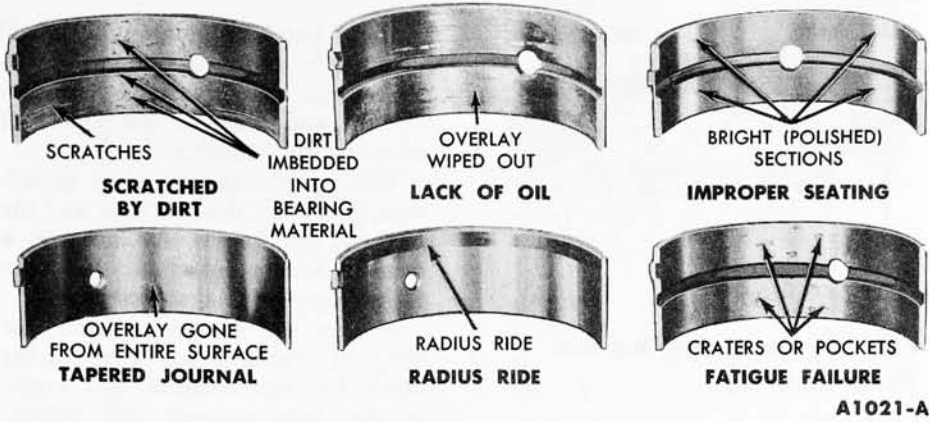


FIG. 59—Typical Bearing Failures

manifold, cylinder heads, oil pan and oil pump following the procedures in this section.

2. Remove any ridge and/or deposits from the upper end of the cylinder bores as follows:

Turn the crankshaft until the piston to be removed is at the bottom of its travel and place a cloth on the piston head to collect the cuttings. Remove any ridge and/or deposits from the upper end of the cylinder bores. Remove the cylinder ridge with a ridge cutter. Follow the instructions furnished by the tool manufacturer. **Never cut into the ring travel area in excess of 1/32 inch when removing ridges.**

3. Make sure all connecting rod caps are marked so that they can be installed in their original locations.

4. Turn the crankshaft until the connecting rod being removed is down.

5. Remove the connecting rod cap.

6. Push the connecting rod and piston assembly out the top of the cylinder with the handle end of a hammer. **Avoid damage to the crankshaft journal or the cylinder wall when removing the piston and rod.**

7. Remove the bearing inserts from the connecting rod and cap.

8. Install the cap on the connecting rod from which it was removed.

**INSTALLATION**

1. If new piston rings are to be installed, remove the cylinder wall deposits. Follow the instructions of the manufacturer.

**2. fitted. The connecting rods and bearing caps are numbered from 1 to 4 in the right bank and from 5 to 8 in the left bank beginning at the front of the engine. The numbers on the connecting rod and bearing cap must be on the same side when installed in the cylinder bore. If a connecting rod is ever transposed from one block or cylinder to another, new bearings should be fitted and the connecting rod should be numbered to correspond with the new cylinder number.**

3. Make sure the ring gaps are properly spaced around the circumference of the piston.

4. Install a piston ring compressor on the piston and push the piston in with a hammer handle until it is slightly below the top of the cylinder (Fig. 60). Be sure to guide the connecting rods to avoid damaging the crankshaft journals. **Install the piston with the indentation in the piston head toward the front of the engine.**

5. Check the clearance of each bearing by following the procedure

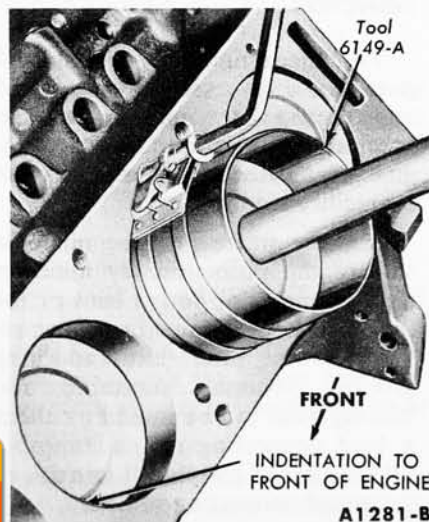


FIG. 60—Piston Installation

under "Connecting Rod Bearing Replacement."

6. After the bearings have been fitted, apply a light coat of engine oil to the journals and bearings.

7. Turn the crankshaft throw to the bottom of its stroke. Push the piston all the way down until the connecting rod bearing seats on the crankshaft journal.

8. Install the connecting rod cap. Torque the nuts to specifications.

9. After the piston and connecting rod assemblies have been installed, check the side clearance between the connecting rods on each crankshaft journal (Fig. 61).

10. Disassemble, clean, and assemble the oil pump. Clean the oil pump inlet tube screen, and the oil pan and block gasket surfaces.

11. Install the oil pump and the oil pan.

12. Install the cylinder heads by following steps 1 thru 5 under "Cylinder Head Installation."

13. Refer to "Intake Manifold Installation" and install the intake manifold by following steps 2 through 19.

14. Fill and bleed the cooling system. Fill the crankcase with the proper grade and quantity of engine oil.

15. Operate the engine and check for oil and coolant leaks. Check and

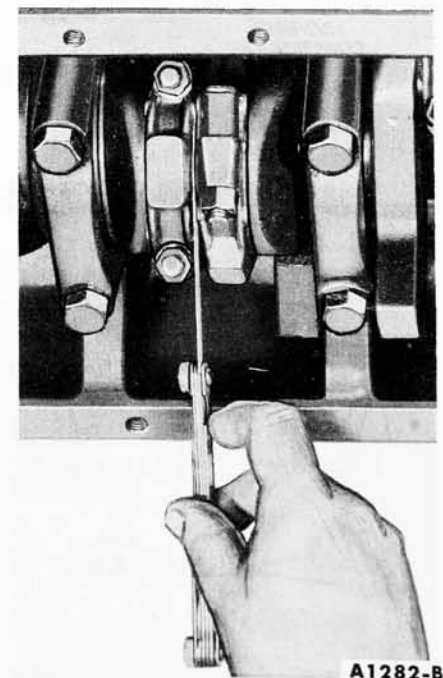


FIG. 61—Connecting Rod Side Clearance

**100% SATISFACTION GUARANTEED**

**BUY IT NOW!**

**Click Here To Order**

PayPal, American Express, Discover, MasterCard, VISA

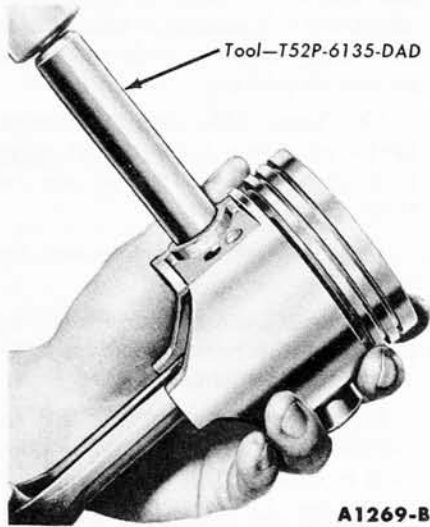
adjust the ignition timing. Adjust the engine idle speed and fuel mixture.

16. Install the air cleaner.

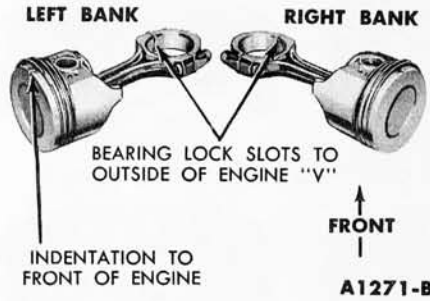
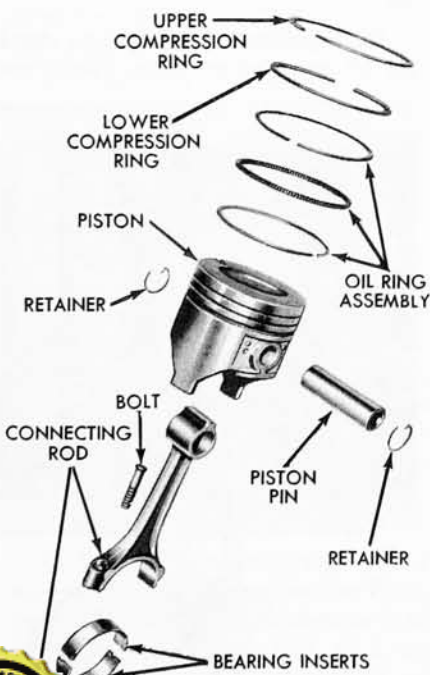
**DISASSEMBLY**

1. Mark the pistons and pins to assure assembly with the same rod and installation in the same cylinder from which they were removed.

2. Remove the piston rings. Remove the piston pin retainers. Drive the pin out of the piston and connecting rod (Fig. 62). Discard the retainers.



**FIG. 62—Piston Pin Removal**



**FIG. 64—Connecting Rod and Piston Assembly**

**ASSEMBLY**

The piston, connecting rod, and related parts are shown in Fig. 63.

1. Lubricate all parts with light engine oil. Position the connecting rod in the piston and push the pin into place. Assemble the piston and connecting rod as shown in Fig. 64.

2. Insert new piston pin retainers by spiraling them into the piston with the fingers. Do not use pliers. Follow the instructions contained on the piston ring package and install the piston rings.

3. Check the ring side clearance of the compression rings with a feeler gauge inserted between the ring and its lower land (step 6 under "Fitting Piston Rings").

4. Be sure the bearing inserts and the bearing bore in the connecting rod and cap are clean. Foreign material under the inserts may distort the bearing and cause a failure. Install the bearing inserts in the connecting rod and cap with the tangs fitting in the slots provided.

**CONNECTING ROD CLEANING AND INSPECTION**

The connecting rods and related parts should be carefully inspected and checked for conformance to specifications. Various forms of engine wear caused by these parts can be readily identified.

A shiny surface on the pin boss side of the piston usually indicates that a connecting rod is bent or the piston pin hole is not in proper relation to the piston skirt and ring grooves. Abnormal connecting rod bearing wear can be caused by either a bent connecting rod, an improperly machined crankshaft journal, or a tapered connecting rod bore.

Twisted connecting rods will not create an easily identifiable wear

pattern, but badly twisted rods will disturb the action of the entire piston, rings, and connecting rod assembly and may be the cause of excessive oil consumption.

Clean the connecting rod in solvent, including the rod bore and the back of the inserts. **Do not use a caustic cleaning solution.** Blow out all passages with compressed air.

Inspect the connecting rods for signs of fractures and the bearing bores for out-of-round and taper. If the bore exceeds the recommended limits and/or if the connecting rod is fractured, it should be replaced.

Check the piston pin to connecting rod bushing clearance. Replace the connecting rod if the bushing is so worn that it cannot be reamed or honed for an oversize pin.

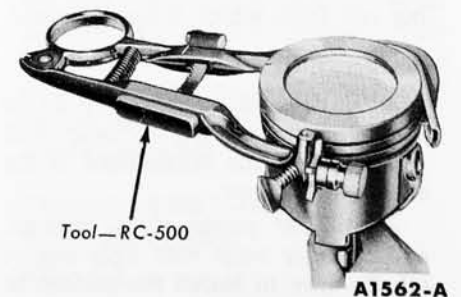
Replace defective connecting rod nuts and bolts.

After the connecting rods are assembled to the piston, check the connecting rods for bend or twist on a suitable alignment fixture. Follow the instructions of the fixture manufacturer. If the bend and/or twist is excessive, the connecting rod should be straightened or replaced.

**PISTONS, PINS, AND RINGS CLEANING AND INSPECTION**

Remove deposits from the piston surfaces. Clean gum or varnish from the piston skirt, piston pins, and rings with solvent. **Do not use a caustic cleaning solution or a wire brush to clean pistons.** Clean the ring grooves with a ring groove cleaner (Fig. 65). Make sure the oil ring slots (or holes) are clean.

Carefully inspect the pistons for fractures at the ring lands, skirts, and pin bosses, and for scuffed, rough, or scored skirts. If the lower inner portion of the ring grooves have high steps, replace the piston. The step will interfere with ring operation and cause excessive ring side clearance.



**FIG. 65—Cleaning Ring Grooves**

**100% SATISFACTION GUARANTEED**

**BUY IT NOW!**

**Click Here To Order**

PayPal, American Express, Discover, MasterCard, VISA

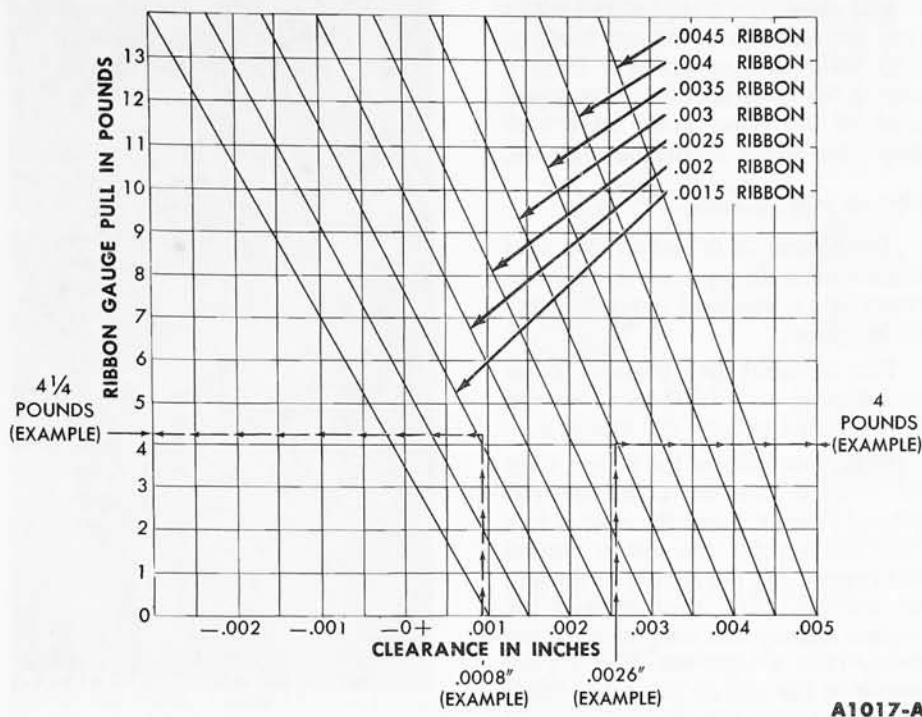


FIG. 66—Piston Clearance Chart

Spongy, eroded areas near the edge of the top of the piston are usually caused by detonation, or pre-ignition. A shiny surface on the thrust surface of the piston, offset from the centerline between the piston pin holes, can be caused by a bent connecting rod. Replace pistons that show signs of excessive wear, wavy ring lands, fractures, and/or damage from detonation or pre-ignition.

Check the piston to cylinder bore clearance with a tension scale and ribbon by following the procedure under "Fitting Pistons." Check the ring side clearance by following the procedure under "Fitting Piston Rings."

Replace piston pins showing signs of fracture or etching and/or wear. Check the piston pin fit in the piston and rod.

Replace all rings that are scored, chipped, or cracked. It is good practice to always install new rings when overhauling the engine. **Rings should not be transferred from one piston to another regardless of mileage.**

#### FITTING PISTONS

are available for service sizes and 0.020, 0.030

**100% SATISFACTION GUARANTEED**

**BUY IT NOW!**

**Click Here To Order**

PayPal American Express Discover Novus MasterCard VISA

er size piston has been selected, check for a damaged piston, then try a new piston.

If the clearance is less than the minimum limit, recheck calculations before trying another piston. If none can be fitted, refinish the cylinder for the next size piston. **When a piston has been fitted, mark it for assembly in the cylinder to which it was fitted.**

If the taper and out-of-round conditions of the cylinder bore are within limits, new piston rings will give satisfactory service provided the piston clearance in the cylinder bore is within limits. If the new rings are to be installed in a used cylinder that has not been refinished, remove the cylinder wall "glaze."

#### To fit a piston:

1. Calculate the size piston to be used by taking a cylinder bore check (Fig. 86).
2. Select the proper size piston to provide the desired clearance.
3. Make sure the piston and cylinder bore are at room temperature (70°F). After any refinishing operation, allow the cylinder bore to cool and make sure the piston and bore are clean and dry before the piston fit is checked.

4. Attach a tension scale to the end of a feeler gauge ribbon that is free of dents or burrs. The feeler ribbon should be 1/2-inch wide and

of one of the thicknesses shown in Fig. 66.

5. Position the ribbon in the cylinder bore so that it extends the entire length of the piston at 90° from the piston pin location. Invert the piston and install it in the bore so that the end of the piston is about 1 1/2 inches below the top of the cylinder block and the piston pin is parallel to the crankshaft axis. Hold the piston and slowly pull the scale in a straight line with the ribbon, noting the pull required to remove the feeler ribbon (Fig. 67).

In Fig. 66 the diagonal lines represent feeler ribbons of various thicknesses, the horizontal lines represent the pounds pull, and the vertical lines represent the clearances. To determine the clearance, locate the line representing the pounds pull required to remove the feeler ribbon from the cylinder bore. Follow the horizontal line to the right until it intersects the diagonal line representing the feeler ribbon. Read down the vertical line for the clearance.

**Example 1.** If a 0.0015-inch feeler ribbon is used and it takes approximately 4 1/4-pounds pull to remove the feeler ribbon, the clearance is approximately 0.0008 inch. This is determined by locating the pounds pull (4 1/4) in Fig. 66 and following the line to the right until it intersects with the diagonal line representing the 0.0015-inch feeler ribbon. Read down the vertical line for the clear-

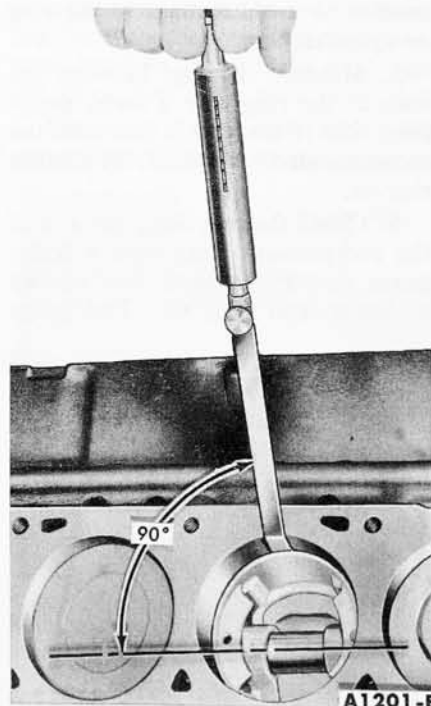
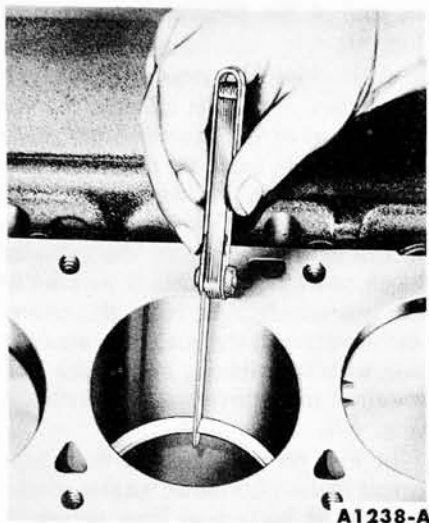


FIG. 67—Checking Piston Fit



A1238-A

**FIG. 68—Piston Ring Gap**

ance (approximately 0.0008 inch).

**Example 2.** If a 0.003-inch feeler ribbon is used and it takes approximately 9-pounds pull to remove the ribbon, the resultant clearance is approximately 0.0015 inch.

#### FITTING PISTON RINGS

1. Select the proper ring set for the size piston to be used.
2. Position the ring in the cylinder bore in which it is going to be used.
3. Push the ring down into the cylinder bore area where normal ring wear is not encountered.
4. Use the head of a piston to position the ring so that the ring is square with the cylinder wall. Use **caution to avoid damage to the ring or cylinder bore.**
5. Measure the gap between the ends of the ring with a feeler gauge (Fig. 68). If the gap is less than the recommended lower limit, try another ring set.
6. Check the ring side clearance of the compression rings with a feeler gauge inserted between the ring and its lower land (Fig. 69). The gauge

should slide freely around the entire ring circumference without binding. Any wear that occurs will form a step at the inner portion of the lower land. **If the lower lands have high steps, the piston should be replaced.**

#### FITTING PISTON PINS

The piston pin fit should be a light thumb press fit at normal temperature (70°F). Standard piston pins are coded green.

Pins of 0.001-inch oversize (color coded blue) and 0.002-inch oversize (color coded yellow) are available.

If the pin hole in the piston must be reamed, use an expansion-type piloted reamer. Place the reamer in a vise and revolve the piston around the reamer. Set the reamer to the size of the pin bore, then expand the reamer slightly and trial ream the pin bore. Take a light cut. Use a pilot sleeve of the nearest size to maintain alignment of the bores.

Check the hole size, using the new piston pin. If the bore is small, expand the reamer slightly and make another cut. Repeat the procedure until the proper fit is obtained. Check the piston pin for fit in the respective rod bushing. If necessary, ream or hone the bushing to fit the pin.

#### FLYWHEEL

##### REMOVAL

1. Disconnect the transmission from the engine and slide it to the rear as outlined in Part 5-4.
2. Remove the flywheel retaining bolts and remove the flywheel.

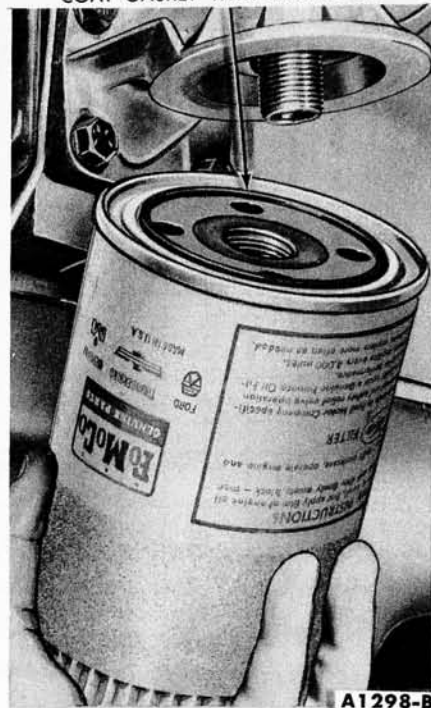
##### INSTALLATION

1. Install the flywheel on the crankshaft flange and install the retaining bolts. Torque the bolts in sequence across from each other to specifications.
2. Connect the transmission to the engine as outlined in Part 5-4.

#### OIL FILTER REPLACEMENT

1. Place a drip pan under the filter. Unscrew the filter from the adapter fitting. Clean the filter adapter recess.
2. Coat the gasket on the new filter with oil, and place the filter in position on the adapter (Fig. 70). Hand tighten the filter until the gasket contacts the adapter face, then advance it ½ turn.

COAT GASKET WITH ENGINE OIL



A1298-B

**FIG. 70—Oil Filter Replacement**

3. Operate the engine at fast idle and check for leaks. If oil leaks are evident, perform the necessary repairs to correct the leakage. Check the oil level and fill the crankcase if necessary.

#### OIL PAN AND OIL PUMP

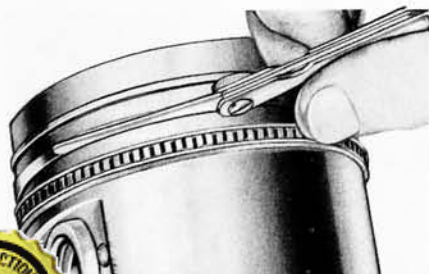
##### REMOVAL

1. Drain the cooling system and the crankcase. Disconnect the radiator upper hose at the radiator supply tank.
2. Remove the oil pan retaining screws and lower the oil pan to the underbody cross member. Position the crankshaft so that the counterweight will clear the oil pan and move the pan forward.
3. Install the engine lifting brackets and sling. Raise the engine high enough to place tension on the engine mounts.

4. Remove the engine front insulator to engine retaining bolts. Raise the engine high enough to permit removal of the oil pump retaining bolts, then remove the bolts. Remove the oil pan and the oil pump.

##### INSTALLATION

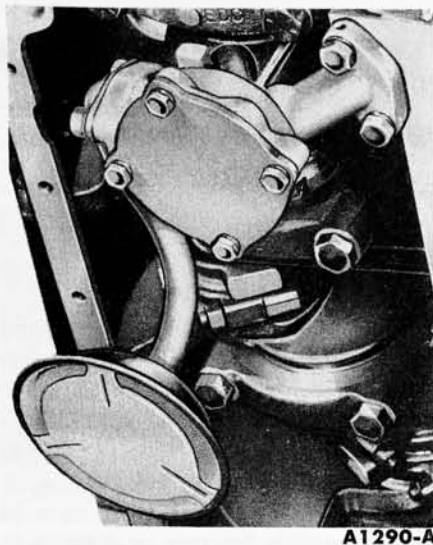
1. Clean the oil pan and block gasket surfaces. Position a new gasket on the oil pan.
2. Clean the oil pump and inlet



**BUY IT NOW!**

**Click Here To Order**





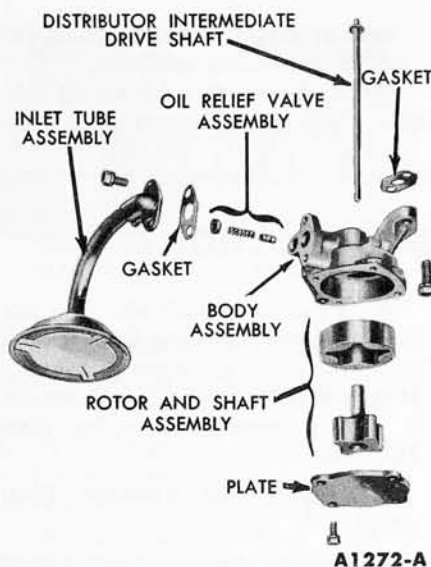
**FIG. 71—Oil Pump and Inlet Tube Installed**

tube screen. Position a new oil pump inlet tube gasket on the oil pump and install the tube. Prime the oil pump by filling either the inlet or outlet port with engine oil. Rotate the pump shaft to distribute the oil within the pump body.

3. Raise the engine high enough to allow installation of the oil pump and the oil pan. Place the oil pump in the oil pan and position the oil pan on the underbody cross member. Insert the oil pump drive shaft into the oil pump housing and install the oil pump and shaft as an assembly (Fig. 71). **Do not attempt to force the pump into position if it will not seat readily. The drive shaft hex may be misaligned with the distributor shaft. To align, rotate the intermediate shaft into a new position.** Torque the oil pump retaining screws to specifications.

4. Hold the oil pan in place against the cylinder block and install a retaining screw on each side of the oil pan. Install the remaining screws and torque them, from the center outward, to specifications.

5. Lower the engine, then install the engine right and left front support retaining bolts. Torque the bolts to specifications. Remove the engine lifting bracket and sling. Connect the radiator upper hose. Fill and bleed the cooling system. Fill the crankcase with the proper grade and quantity of engine oil. Operate the engine and check for leaks.



**FIG. 72—Oil Pump Assembly**

screws, then remove the cover. Remove the inner rotor and shaft assembly, then remove the outer race.

3. Insert a self-threading sheet metal screw of the proper diameter into the oil pressure relief valve chamber cap and pull the cap out of the chamber. Remove the spring and plunger.

#### OIL PUMP ASSEMBLY

The oil pump assembly is shown in Fig. 72.

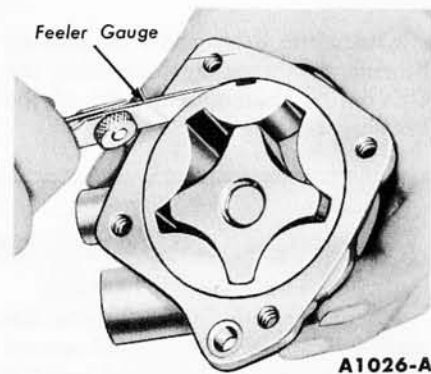
1. Oil all parts thoroughly.
2. Install the oil pressure relief valve plunger, spring, and a new cap.
3. Install the outer race, and the inner rotor and shaft assembly. **The inner rotor and shaft, and the outer race are serviced as an assembly. One part should not be replaced without replacing the other.** Install the cover. Torque the cover retaining screws to specifications.

4. Position a new gasket and the oil inlet tube on the oil pump and install the retaining bolts.

#### OIL PAN CLEANING AND INSPECTION

Scrape any dirt or metal particles from the inside of the pan. Scrape all old gasket material from the gasket surface. Wash the pan in a solvent and dry it thoroughly. Be sure all foreign matter is removed from below the baffle plate.

Check the pan for cracks, holes, damaged drain plug threads, a loose baffle, and a nicked or warped gasket surface.



**FIG. 73—Outer Race To Housing Clearance**

Repair any damage, or replace the pan if repairs can not be made.

#### OIL PUMP CLEANING AND INSPECTION

Wash all parts in a solvent and dry them thoroughly. Use a brush to clean the inside of the pump housing and the pressure relief valve chamber. Be sure all dirt and chips are removed.

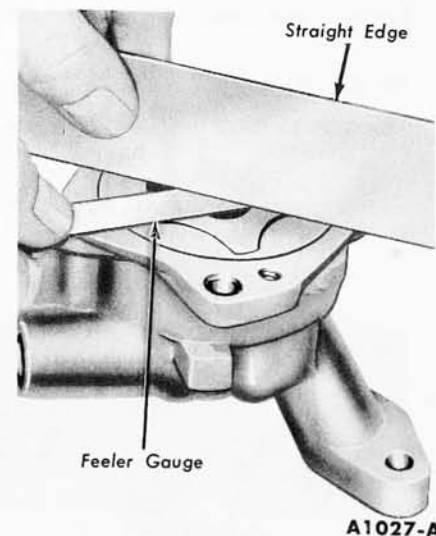
Check the inside of the pump housing and the outer race and rotor for damage or excessive wear.

Check the mating surface of the pump cover for wear. If the cover mating surface is worn, scored, or grooved, replace the cover.

Measure the outer race to housing clearance (Fig. 73).

With the rotor assembly installed in the housing, place a straight edge over the rotor assembly and the housing. Measure the rotor end play clearance between the straight edge and the rotor and outer race (Fig. 74).

**The outer race, shaft and rotor are replaceable only as an assembly,**



**FIG. 74—Rotor End Play**

**100% SATISFACTION GUARANTEED**

**BUY IT NOW!**

**Click Here To Order**

PayPal American Express Discover Novus MasterCard VISA

Check the drive shaft to housing bearing clearance by measuring the OD of the shaft and the ID of the housing bearing.

Inspect the relief valve spring for a collapsed or worn condition.

Check the relief valve spring tension. If the spring tension is not with-

in specifications and/or the spring is defective, replace the spring.

Check the relief valve piston for scores and free operation in the bore.

## 6 WORK STAND REPAIR OPERATIONS

To perform the operations in this section, it will be necessary to remove the engine from the car and install it on a work stand.

### CRANKSHAFT

#### REMOVAL

The crankshaft and related parts are shown in Fig. 75.

1. Remove the generator adjusting arm bracket bolt from the generator and the upper support bracket bolt at the water pump. Remove the spark plugs to allow easy rotation of the crankshaft.

2. Remove the fuel pump. Slide the water pump by-pass hose clamp toward the rear of the engine. Remove the water pump and fan as an assembly.

3. Remove the crankshaft damper, cap screw and washer. Install the puller on the damper (Fig. 45) and remove the damper.

4. If the crankshaft sleeve is not stepped down (the same OD on both ends), remove it as shown in Fig. 46. If the sleeve is stepped down, remove it with a three-jawed puller (tool 7675-N).

5. Remove the cylinder front cover.

6. Remove the oil slinger. Check the timing chain deflection, then remove the timing chain and sprockets by following steps 13 thru 18 under "Cylinder Front Cover Removal."

7. Invert the engine on the work stand. Remove the flywheel. Remove the oil pan and gasket. Remove the oil pump.

8. **Make sure all bearing caps (main and connecting rod) are marked so that they can be installed in their original locations.** Remove the connecting rod bearing caps. Turn the crankshaft until the connecting rod from which the cap is being removed is down and remove

the cap. Push the connecting rod and piston assembly up into the cylinder.

9. Remove the main bearing caps.

10. Carefully lift the crankshaft out of the block so that the thrust bearing surfaces are not damaged. **Handle the crankshaft with care to avoid possible fracture or damage to the finished surfaces.**

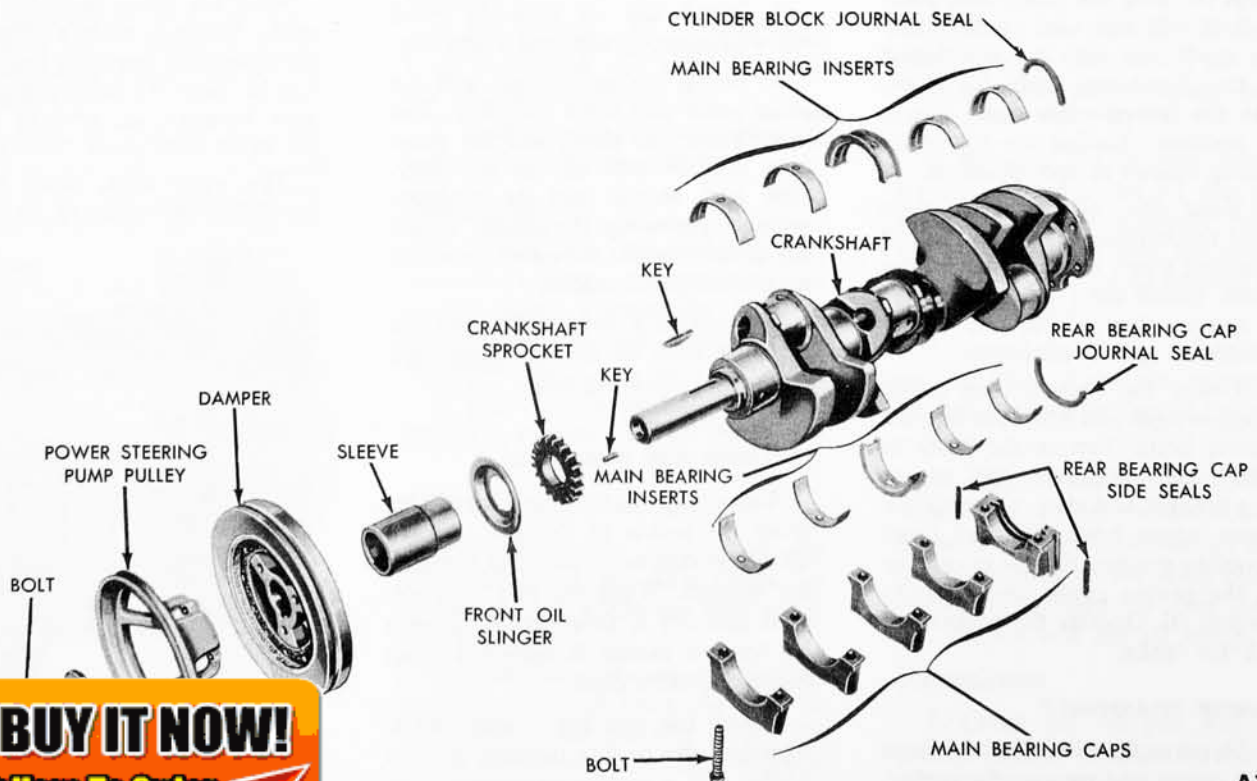
#### INSTALLATION

1. Remove the rear journal oil seal from the block and rear main bearing cap. Remove the rear main bearing cap to block side seals.

2. Remove the main bearing inserts from the block and bearing caps.

3. Remove the connecting rod bearing inserts from the connecting rods and caps.

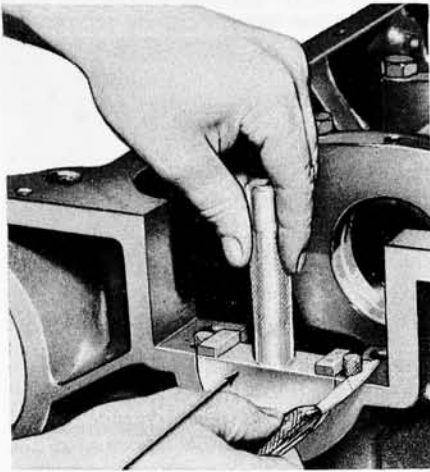
4. If the crankshaft main bearing journals have been refinished to a definite undersize, install the correct undersize bearings. Be sure the bearing inserts and bearing bores are clean. Foreign material under the in-



**BUY IT NOW!**

Click Here To Order





**FIG. 76—Seal To Block Installation**

serts may distort the bearing and cause a failure.

5. Place the upper main bearing inserts in position in the bores with the tang fitting in the slot provided.

6. Install the lower main bearing inserts in the bearing caps.

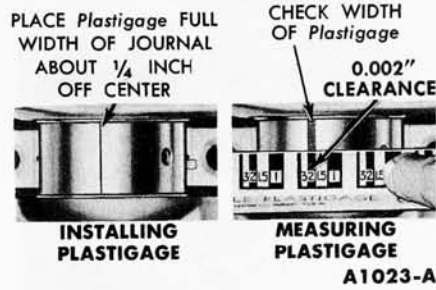
7. Install a new rear journal oil seal in the block (Fig. 76). After installation, cut the ends of the seals flush.

8. Carefully lower the crankshaft into place. **Be careful not to damage the bearing surfaces.**

9. Check the clearance of each main bearing as follows:

Place a piece of Plastigage on the crankshaft journal the full width of the journal and about 1/4 inch off center (Fig. 77). Follow steps 10 thru 12 under "Main Bearing Replacement."

10. After the bearings have been fitted, apply a light coat of engine



**FIG. 77—Installing & Measuring Plastigage—Engine Removed**

oil to the journals and bearings. Install a new seal in the rear main bearing cap and install the rear main bearing cap by following steps 3 thru 7 under "Crankshaft Lower Rear Oil Seal Replacement." Install all the bearing caps, except the thrust bearing cap (No. 3 bearing). **Be sure that the main bearing caps are installed in their original locations.** Torque the bearing cap bolts to specifications.

11. Install the thrust bearing cap with the bolts finger-tight.

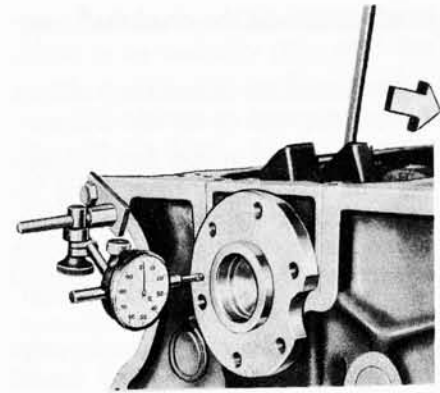
12. Pry the crankshaft forward against the thrust surface of the upper half of the bearing (Fig. 78).

13. Hold the crankshaft forward and pry the thrust bearing cap to the rear (Fig. 78). This will align the thrust surfaces of both halves of the bearing.

14. Retain the forward pressure on the crankshaft. Tighten the cap bolts to specifications (Fig. 78).

15. Force the crankshaft toward the rear of the engine.

16. Install a dial indicator so that the contact point rests against the crankshaft flange and the indicator axis is parallel to the crankshaft axis



**FIG. 79—Crankshaft End Play**

(Fig. 79).

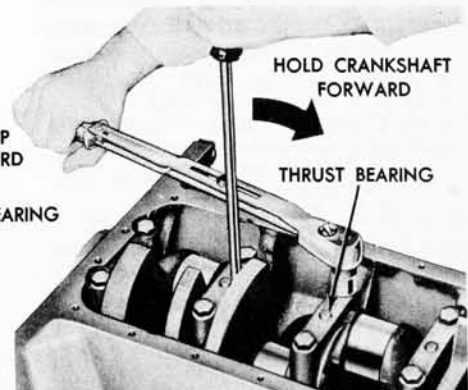
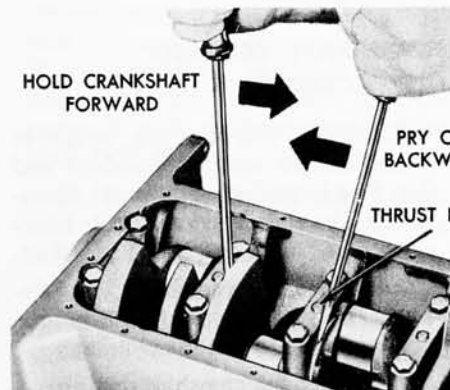
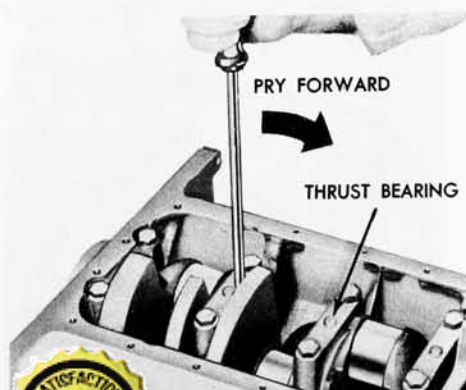
17. Zero the dial indicator. Push the crankshaft forward and note the reading on the dial.

If the end play exceeds the wear limit, replace the thrust bearing. If the end play is less than the minimum limit, inspect the thrust bearing faces for scratches, burrs, nicks, or dirt. If the thrust faces are not defective or dirty, they probably were not aligned properly. Install the thrust bearing and align the faces following the recommended procedure (steps 11, 12, 13, and 14), then check the end play.

18. Install new bearing inserts in the connecting rods and caps. Check the clearance of each bearing by following the procedure under "Main Bearing Replacement."

19. After the connecting rod bearings have been fitted, apply a light coat of engine oil to the journals and bearings.

20. Turn the crankshaft throw to the bottom of its stroke. Push the piston all the way down until the rod



**100% SATISFACTION GUARANTEED**

**BUY IT NOW!**

**Click Here To Order**

PayPal, American Express, Discover, MasterCard, VISA

FIG.

A1279-A

bearing seats on the crankshaft journal.

21. Install the connecting rod cap. Torque the nuts to specifications.

22. After the piston and connecting rod assemblies have been installed, check the side clearance between the connecting rods on each connecting rod crankshaft journal (Fig. 61).

23. Clean the oil pan, oil pump, and oil pump screen. Install the oil pump and oil pan.

24. Position the flywheel on the crankshaft. Install the retaining bolts. Torque the bolts to specifications.

25. Install the timing chain and sprockets, cylinder front cover and crankshaft damper, following steps 1 thru 8 under "Cylinder Front Cover Installation."

26. Install the oil filter, fuel pump, and carburetor fuel inlet line. Install the generator. Install the spark plugs.

27. Install the engine in the car.

#### CLEANING AND INSPECTION

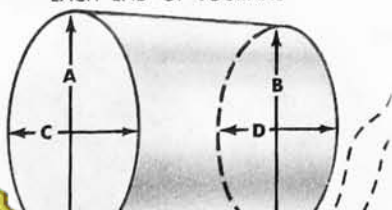
Handle the crankshaft with care to avoid possible fractures or damage to the finished surfaces. Clean the crankshaft with solvent, then blow out all oil passages with compressed air.

Inspect main and connecting rod journals for cracks, scratches, grooves, or scores. Dress minor imperfections with an oilstone. Refinish severely marred journals.

Measure the diameter of each journal in at least four places to determine out-of-round, taper, or undersize condition (Fig. 80).

If the journals exceed the wear limit, they should be refinished to size for the next undersize bearing.

- A VS B = VERTICAL TAPER  
 C VS D = HORIZONTAL TAPER  
 A VS C AND B VS D = OUT-OF-ROUND  
 CHECK FOR OUT-OF-ROUND AT EACH END OF JOURNAL



Tool—T52L-6261-CEE

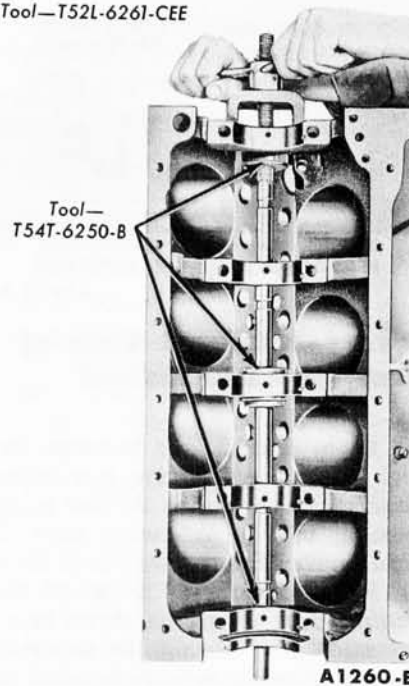


FIG. 81—Camshaft Bearing Replacement

**Refinishing Journals.** Refinish the journal to give the proper clearance with the next undersize bearing. If the journal will not "clean up" to give the proper clearance with the maximum undersize bearing available, replace the crankshaft.

Always reproduce the same journal shoulder radius that existed originally. Too small a radius will result in fatigue failure of the crankshaft. Too large a radius will result in bearing failure due to radius ride of the bearing.

After refinishing the journals, chamfer the oil holes, then polish the journal with a No. 320 grit polishing cloth and engine oil. Crocus cloth may be used also as a polishing agent.

#### CAMSHAFT BEARING REPLACEMENT

Camshaft bearings are available prefinished to size for standard and 0.015-inch undersize journal diameters. The bearings are not interchangeable from one bore to another.

1. Remove the camshaft, the flywheel, and the crankshaft. Push the pistons to the top of the cylinders.

2. Remove the camshaft rear bearing bore plug. Remove the camshaft bearings (Fig. 81).

3. Position the new bearings at the bearing bores, and press them in place with the tool shown in Fig. 81.

INSTALL FRONT BEARING 0.005-0.020 INCH BELOW FRONT FACE OF BLOCK

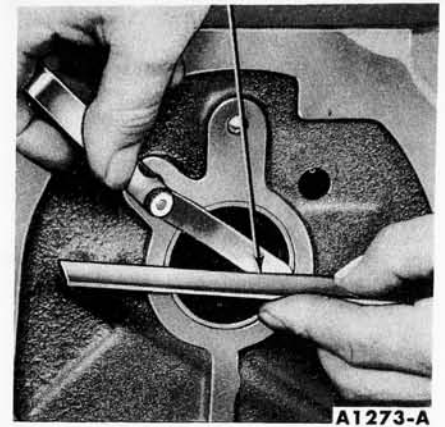


FIG. 82—Camshaft Front Bearing Measurement

Align the oil holes in the bearings with the oil holes in the cylinder block when the bearings are installed. Be sure the camshaft front bearing is installed 0.005-0.020 inch below the front face of the cylinder block (Fig. 82).

4. Clean out the camshaft rear bearing bore plug recess thoroughly. Coat the flange of a new plug with water resistant sealer and install the plug (Fig. 83).

5. Install the camshaft, crankshaft, flywheel, and related parts. Install the engine in the car.

#### ENGINE DISASSEMBLY

1. Install the engine on the work stand (Fig. 17).

2. Remove the distributor cap and spark plug wire assembly.

3. Disconnect the distributor vacuum line at the distributor. Remove the carburetor fuel inlet line. Remove the fuel pump and discard the gasket.

4. Slide the clamp on the water

Tool—T58P-6266-A

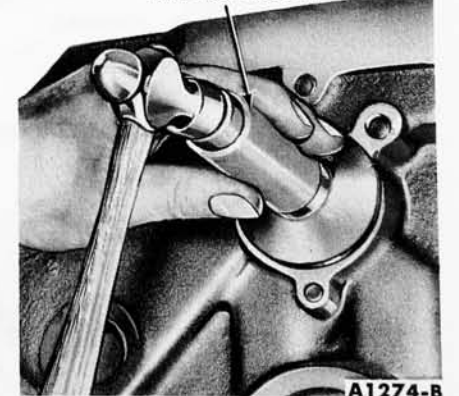


FIG. 83—Camshaft Rear Bearing Bore Plug Installation

**100% SATISFACTION GUARANTEED**

**BUY IT NOW!**

**Click Here To Order**

PayPal, American Express, Discover, MasterCard, VISA

pump by-pass hose toward the water pump. Remove the automatic choke heat tube. Remove the valve rocker arm covers.

5. Crank the engine until the No. 1 piston is at TDC at the end of the compression stroke. Rotate the crankshaft damper an additional 45° (identified on the damper by "XX"). Starting at the No. 4 cylinder, loosen the right rocker arm shaft support bolts in sequence, two turns at a time. After the bolts are all loosened, remove the valve rocker arm shaft assembly and the oil baffle plate. Starting at the No. 5 cylinder, follow the same procedure on the left valve rocker arm shaft support bolts. **This procedure must be followed to avoid damage to the valve mechanism.**

6. Remove the valve push rods in sequence and put them in a rack so that they can be installed in their original bore.

7. Remove the distributor hold down bolt and clamp and remove the distributor.

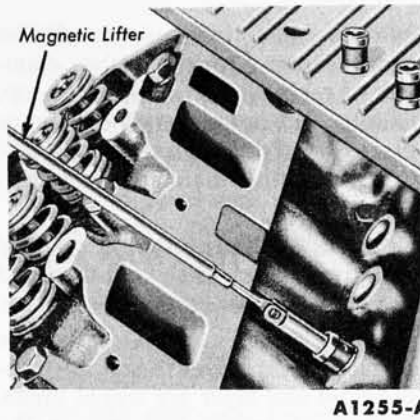
8. Remove the intake manifold retaining bolts.

9. Install standard eye bolts with 5/16-18 threads in the left front and right rear rocker arm cover screw holes and attach the engine lifting sling (Fig. 16).

10. Raise the manifold and carefully remove it from the engine. Discard the intake manifold gaskets and seals.

11. Remove the baffle plate from the valve push rod chamber floor by prying up on the baffle with a screw driver (Fig. 84).

12. Lift the valve lifters from the cylinder block and place them in a rack so that they can be installed in



**FIG. 85—Hydraulic Valve Lifter Removal**

their original bore (Fig. 85). **The internal parts of each hydraulic valve lifter assembly are matched sets. Do not intermix the parts. Keep the assemblies intact until they are to be cleaned.**

13. Remove the exhaust manifolds and the spark plugs.

14. Remove the cylinder head bolts, and then install the cylinder head holding fixtures (Fig. 26).

15. Lift the cylinder heads off the block. **Do not pry between the head and the block.** Discard the cylinder head gaskets.

16. Remove the oil filter. Remove the oil filter adapter assembly and oil pressure sending unit as an assembly. Discard the gasket.

17. Remove the generator, brackets, and drive belts.

18. Remove the water pump, pulley, and fan as an assembly.

19. Remove the power steering pulley. Remove the crankshaft damper (Fig. 45).

20. If the crankshaft sleeve is not stepped down (the same OD on both ends), remove it as shown in Fig. 46. If the crankshaft sleeve is stepped down (different OD on each end), remove it with a three-jawed puller (tool 7675-N).

21. Remove the cylinder front cover. Discard the gasket. Remove the crankshaft front oil slinger.

22. Check the timing chain deflection by following steps 13, 14, and 15 under "Cylinder Front Cover and Timing Chain Removal."

23. Remove the camshaft thrust button and spring, the sprocket cap screw, and thrust button spring retainer, and the fuel pump eccentric. Remove the crankshaft sprocket key.

Remove the sprockets and timing chain as an assembly (Fig. 49).

24. Remove any ridge and/or carbon deposits from the upper end of the cylinder bores. Move the piston to the bottom of its travel and place a cloth on the piston head to collect the cuttings. Remove the cylinder ridge with a ridge cutter. Follow the instructions furnished by the tool manufacturer. **Never cut into the ring travel area in excess of 1/32 inch when removing ridges.** After the ridge has been removed, remove the cutter from the cylinder bore.

25. Remove the flywheel.

26. Invert the engine. Remove the oil pan. Discard the gasket.

27. Remove the oil pump and inlet tube as an assembly. Remove the oil pump drive shaft. Discard the oil pump gasket.

28. **Make sure all connecting rods and caps are marked so that they can be installed in their original locations.** Turn the crankshaft until the connecting rod being removed is down. Remove the rod cap.

29. Push the connecting rod and piston assembly out the top of the cylinder with the handle end of a hammer. **Avoid damage to the crankpin or the cylinder wall when removing the piston and rod.**

30. Remove the bearing inserts from the connecting rods and caps. Install the rod caps on the connecting rods from which they were removed.

31. Remove the main bearing caps.

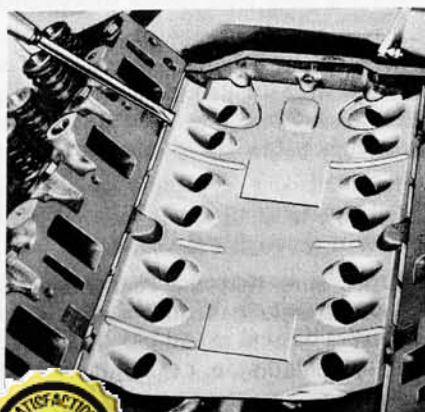
32. Carefully lift the crankshaft out of the cylinder block so that the thrust bearing surfaces are not damaged. **Handle the crankshaft with care to avoid possible fracture or damage to the finished surfaces.**

33. Remove the rear journal oil seal from the block and rear bearing cap, and remove the cap to block side seals.

34. Remove the main bearing inserts from block and bearing caps. Install the main bearing caps in their original positions.

35. Carefully remove the camshaft by pulling it toward the front of the engine. Use caution to avoid damaging the journals and lobes.

36. Remove the camshaft rear bearing bore plug. Remove the camshaft bearings (Fig. 81).



**BUY IT NOW!**

**Click Here To Order**



## CYLINDER BLOCK

### CLEANING AND INSPECTION

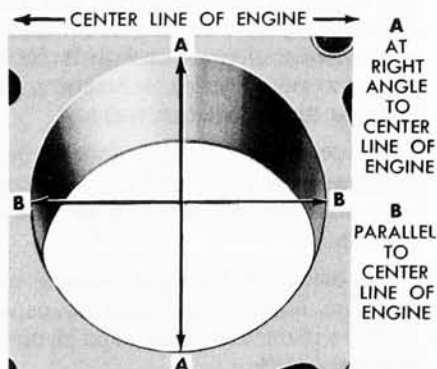
Thoroughly clean the block in solvent. Remove old gasket material from all machined surfaces. Remove all pipe plugs which seal oil passages, then clean out all the passages. Blow out all passages, bolt holes, etc. with compressed air. Make sure the threads in the cylinder head bolt holes are clean. Dirt in the threads may cause binding and result in a false torque reading. Use a tap to true-up threads and to remove any deposits.

After the block has been thoroughly cleaned, make a check for cracks. Minute cracks not visible to the naked eye may be detected by coating the suspected area with a mixture of 25% kerosene and 75% light motor oil. Wipe the part dry and immediately apply a coating of zinc oxide dissolved in wood alcohol. If cracks are present, the coating will become discolored at the defective area. Replace the block if it is cracked.

Check all machined gasket surfaces for burrs, nicks, scratches, and scores. Remove minor imperfections with an oil stone. Check the flatness of the cylinder block gasket surface following the procedure and specifications recommended for the cylinder head.

Replace all expansion-type plugs that show evidence of leakage.

Inspect the cylinder walls for scoring, roughness, or other signs of wear. Check the cylinder bore for out-of-round and taper. Measure the bore with an accurate gauge



1. OUT-OF-ROUND = DIFFERENCE BETWEEN A AND B  
TAPER = DIFFERENCE BETWEEN THE A MEASUREMENT AT TOP OF

following the instructions of the manufacturer. Measure the diameter of each cylinder bore at the top, middle, and bottom with the gauge placed at right angles and parallel to the centerline of the engine (Fig. 86).

Refinish cylinders that are deeply scored and/or when out-of-round and/or taper exceed the wear limits.

If the cylinder walls have minor surface imperfections, but the out-of-round and taper are within limits, it may be possible to remove the imperfections by honing the cylinder walls and installing new service piston rings providing the piston clearance is within limits. Use the finest grade of honing stone for this operation.

### REFINISHING CYLINDER WALLS

Honing is recommended for refinishing cylinder walls only when the walls have minor imperfections, such as light scuffs, scratches, etc. The grade of hone to be used is determined by the amount of metal to be removed. Follow the instructions of the hone manufacturer. If coarse stones are used to start the honing operation, leave enough material so that all hone marks can be removed with the finishing hone which is used to obtain the proper piston clearance.

Cylinder walls that are severely marred and/or worn beyond the specified limits should be refinished. Before any cylinder is refinished, all main bearing caps must be in place and tightened to the proper torque so that the crankshaft bearing bores will not become distorted from the refinishing operation.

Refinish only the cylinder or cylinders that require it. **All pistons are the same weight, both standard and oversize; therefore, various sized pistons can be intermixed without upsetting engine balance.**

Refinish the cylinder with the most wear first to determine the maximum oversize. If the cylinder will not clean up when refinished for the maximum oversize piston recommended, replace the block.

Refinish the cylinder to within approximately 0.0015 inch of the required oversize diameter. This will allow enough stock for the final step of honing so that the correct surface finish and pattern are obtained. Use clear sharp hones of No. 220-280 grit for this operation.

For the proper use of the refinishing equipment, follow the instructions of the manufacturer. Only experienced personnel should be allowed to perform this work.

After the final operation in either of the two refinishing methods described and prior to checking the piston fit, thoroughly wash the cylinder walls with solvent to remove all abrasive particles, then thoroughly dry the walls. Check the piston fit. Mark the pistons to correspond to the cylinders in which they are to be installed. When the refinishing of all cylinders that require it has been completed and all pistons fitted, thoroughly clean the entire block to remove all particles from the bearing bores, oil passages, cylinder head bolt holes, etc. Coat the cylinder walls with oil.

### ENGINE ASSEMBLY

1. Remove the glaze from the cylinder bores by following the instructions of the tool manufacturer.

2. Invert the engine on the work stand.

3. Position the new bearings at the bearing bores, and press them in place with the tool shown in Fig. 81. Align the oil holes in the cylinder block when the bearings are installed. **Be sure the camshaft front bearing is installed 0.005-0.020 inch below the front face of the cylinder block (Fig. 82).**

4. Check the oil passage that feeds the rocker arm shafts for obstructions by squirting oil into the opening on each cylinder bank and observing the flow through the oil holes at Nos. 2 and 4 bearings.

5. Clean out the camshaft rear bearing bore plug recess thoroughly.

6. Coat the flange of a new plug with water resistant sealer and install it with the flange facing out (Fig. 83). Drive the plug in until it is flush or slightly below the casting surface.

7. Oil the camshaft and apply Lubriplate to all lobes, then carefully slide it through the bearings.

8. Be sure that the rear oil seal grooves are clean. Install a new rear journal oil seal in the block (Fig. 76). After installation, cut the ends of the seals flush.

9. If the crankshaft main bearing journals have been refinished to a definite undersize, install the correct undersize bearings. Be sure the bearing inserts and bearing bores are



**BUY IT NOW!**

Click Here To Order



clean. Foreign material under the inserts may distort the bearing and cause a failure.

Place the upper main bearing inserts in position in the bore with the tang fitting in the slot provided.

10. Install the lower main bearing inserts in the bearing caps.

11. Carefully lower the crankshaft into place. **Be careful not to damage the bearing surfaces.**

12. Check the clearance of each main bearing by following the procedure under "Main Bearing Replacement."

13. After the bearings have been fitted, apply a light coat of engine oil to the journals and bearings.

14. Be sure that the oil seal grooves in the rear main bearing cap are clean. Install a new journal seal in the cap (Fig. 57). After installation, cut the ends of the seal flush. Apply a thin coating of oil resistant sealer to the rear main bearing cap at the rear of the top mating surface (Fig. 57). **Do not apply sealer to the area forward of the side seal groove.** Install the rear main bearing cap and the remainder of the caps, except the thrust bearing cap (No. 3 bearing). **Be sure that the main bearing caps are installed in their original locations.** Torque the bearing cap bolts to specifications.

15. Install the thrust bearing cap and check crankshaft end play by following steps 11 thru 17 under "Crankshaft Installation."

16. Turn the engine on the work stand so that the front end is up.

17. Install the pistons and connecting rods by following steps 1 thru 9 under "Piston and Connecting Rod Installation."

18. Position the sprockets and timing chain on the camshaft and crankshaft (Fig. 49). Be sure the timing marks on the sprockets are positioned as shown in Fig. 48.

19. Lubricate the timing chain and sprockets with engine oil.

20. Install the fuel pump eccentric (Fig. 50), the camshaft sprocket and thrust button spring

21. Clean the cylinder front cover and the cylinder block gasket surfaces. Install a new crankshaft front oil seal (Fig. 53).

22. Coat the gasket surface of the block and cover and the cover bolt threads with sealer. Position a new gasket on the block.

23. Install the alignment pilot tool on the cylinder front cover so that the keyway in the pilot aligns with the key in the crankshaft. Position the cover and pilot over the end of the crankshaft and against the block (Fig. 51).

24. Install the cylinder front cover bolts finger-tight. Position the generator support bracket and the generator adjusting arm bracket, then install the bolts (on a car equipped with an air conditioner, connect the compressor and brackets to the cylinder front cover). While pushing in on the pilot, torque the cover bolts to specifications. Remove the pilot.

25. Lubricate the crankshaft with a white lead and oil mixture and lubricate the oil seal rubbing surface with grease.

26. Install the crankshaft sleeve with the smallest OD end into the cylinder front cover bore if the sleeve is stepped down (different OD on each end).

27. Line up the damper keyway with the key on the crankshaft, then install the damper on the crankshaft (Fig. 52). Install the damper cap screw and washer, and torque the screw to specifications.

28. Install the power steering pump pulley on the crankshaft damper.

29. Clean the water pump gasket surfaces and apply sealer. Position new gaskets on the pump and install the water pump, pulley, and fan as an assembly.

30. Using a new gasket, install the fuel pump. Install the generator, brackets, and drive belts.

31. Turn the engine on the work stand so that the top of the engine is up.

32. Clean the cylinder head and block gasket surfaces. Apply sealer to both sides of a new gasket. Guided by the word "FRONT" on the gasket, install the head gasket over the cylinder head dowels.

33. Place the cylinder head on the

engine, then remove the holding fixtures. Coat the head bolt threads with water resistant sealer, and then install the bolts.

34. The cylinder head bolt tightening procedure is performed in three progressive steps. Torque the bolts in sequence (Fig. 27) to 70 ft-lbs, then to 80 ft-lbs, and finally to 90 ft-lbs. **After the cylinder head bolts have been torqued to specifications, the bolts should not be disturbed.**

35. Coat the mating surfaces of the exhaust manifold with a light film of graphite grease.

36. Using a new gasket, install the automatic choke air chamber cover on the right exhaust manifold. **Be sure the cover is securely fastened.**

37. Position a new gasket over the muffler inlet pipe studs of the exhaust manifolds.

38. Position the exhaust manifolds on the cylinder heads and install the retaining bolts and tab washers. Torque the retaining bolts to specifications, working from the center to the ends. Lock the bolts by bending one tab of the washer over a flat on the bolt.

39. Install the spark plugs.

40. Position the baffle plate in the valve push rod chamber. Press it into place (Fig. 87).

41. Coat the outside of each valve lifter with engine oil to provide initial lubrication. **Do not fill the lifters with oil. The lifters will fill much faster after the engine is started, if**



FIG. 87—Baffle Plate Installation

100% SATISFACTION GUARANTEED

**BUY IT NOW!**

Click Here To Order

PayPal

Discover

MasterCard

VISA

they are free of any oil film which may cause an oil seal between the plunger and the lifter body. Place each lifter in the bore from which it was removed.

42. Clean the mating surfaces of the intake manifold, cylinder heads, and cylinder block.

43. Coat the intake manifold and cylinder block seal surfaces with oil resistant sealer.

44. Position new seals on the cylinder block and new gaskets on the cylinder heads. Position the gasket slots in the end tabs over the ribs on the seals. Be sure the holes in the gaskets are aligned with the holes in the cylinder heads. The correct installation of the gaskets and seals are shown in Fig. 23.

45. Install the eye bolts in the intake manifold and attach the engine lifting sling and carefully lower the intake manifold on the engine (Fig. 21).

46. Position the intake manifold by inserting the distributor in place. **After the intake manifold is in place, run a finger around the seal area to make sure the seals are in place. If the seals are not in place, remove the intake manifold and position the seals.**

47. Start the water pump by-pass hose on the intake manifold.

48. Be sure the holes in the manifold gaskets and manifold are in alignment. Install the manifold retaining bolts and torque them to specifications, working from the center to the ends.

49. Remove the distributor and the engine lifting sling and eye bolts.

50. Refer to "Valve Rocker Arm Shaft Assembly Installation" and install the valve rocker arm shaft as-

sembly by following steps 1 thru 6.

51. Install the automatic choke heat tube.

52. Rotate the crankshaft damper until the No. 1 piston is on TDC then position the distributor in the block with the rotor at the No. 1 firing position and the points open. Install the hold down clamp.

53. Connect the distributor vacuum line. Install the distributor cap. Install the valve rocker arm covers.

54. Connect the spark plug wires. Install the carburetor fuel inlet line.

55. Invert the engine on the work stand. Position the oil pump drive shaft into the distributor socket. With the shaft firmly seated in the distributor socket, the stop on the shaft should touch the roof of the crankcase. Remove the shaft and position the stop as necessary.

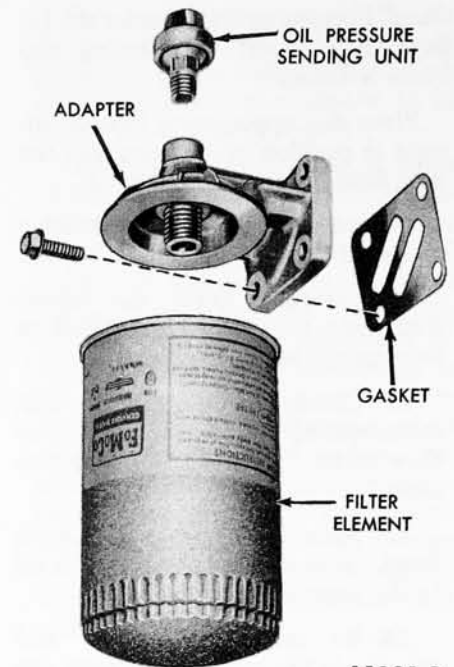
56. With the stop properly positioned, insert the oil pump drive shaft into the oil pump.

57. Prime the oil pump by filling either the inlet or outlet port with engine oil. Rotate the pump shaft to distribute the oil within the pump body.

58. Position a new gasket on the pump housing and install the pump and shaft as an assembly. **Do not attempt to force the pump into position if it will not seat readily. The drive shaft hex may be misaligned with the distributor shaft. To align, rotate the intermediate shaft into a new position.**

59. Position a new gasket on the oil pan and place the oil pan assembly on the block. Install the retaining screws and torque them from the center outward to specifications.

60. Position the flywheel on the crankshaft and install the retaining bolts. Torque the bolts to specifica-



A1291-B

FIG. 88—Oil Filter Assembly

tions.

61. The oil filter assembly is shown in Fig. 88. Clean the oil filter adapter gasket surfaces.

62. Apply sealer to a new adapter gasket, and install the adapter assembly and gasket.

63. Clean the adapter filter recess. Coat the gasket on a new filter with oil. Place the filter in position on the adapter. Hand tighten the filter until the gasket contacts the adapter face, and then advance it 1/2-turn.

64. Install the engine in the car. Operate the engine and check for oil and coolant leaks. Check the ignition timing, adjust the engine idle speed, idle fuel mixture, and anti-stall dashpot.

65. Adjust the transmission control linkage.

## 7 CRANKCASE VENTILATION SYSTEM MAINTENANCE

Refer to Group 12 for the correct mileage interval for maintenance.

### BREATHER CAP

The breather cap located on the filter tube should be cleaned with solvent at the proper mileage interval.

lator valve, exhaust tube, and connections, and outlet adapter. Clean the valve exhaust tube, fittings, and outlet adapter in clean carburetor solvent and dry them with compressed air. Clean the rubber hose connection with a low volatility petroleum base solvent and dry them with compressed air.

### VENT TUBE-TYPE CRANKCASE VENTILATION SYSTEM

The road draft tube seldom re-

quires cleaning except during a high mileage engine overhaul. However, if there is evidence of crankcase pressure, the tube should be checked for excessive sludge and cleaned out if necessary. In addition, the maze screen in the intake manifold baffle plate should be cleaned in solvent to remove any accumulation of sludge deposits.

**100% SATISFACTION GUARANTEED**

**BUY IT NOW!**

**Click Here To Order**

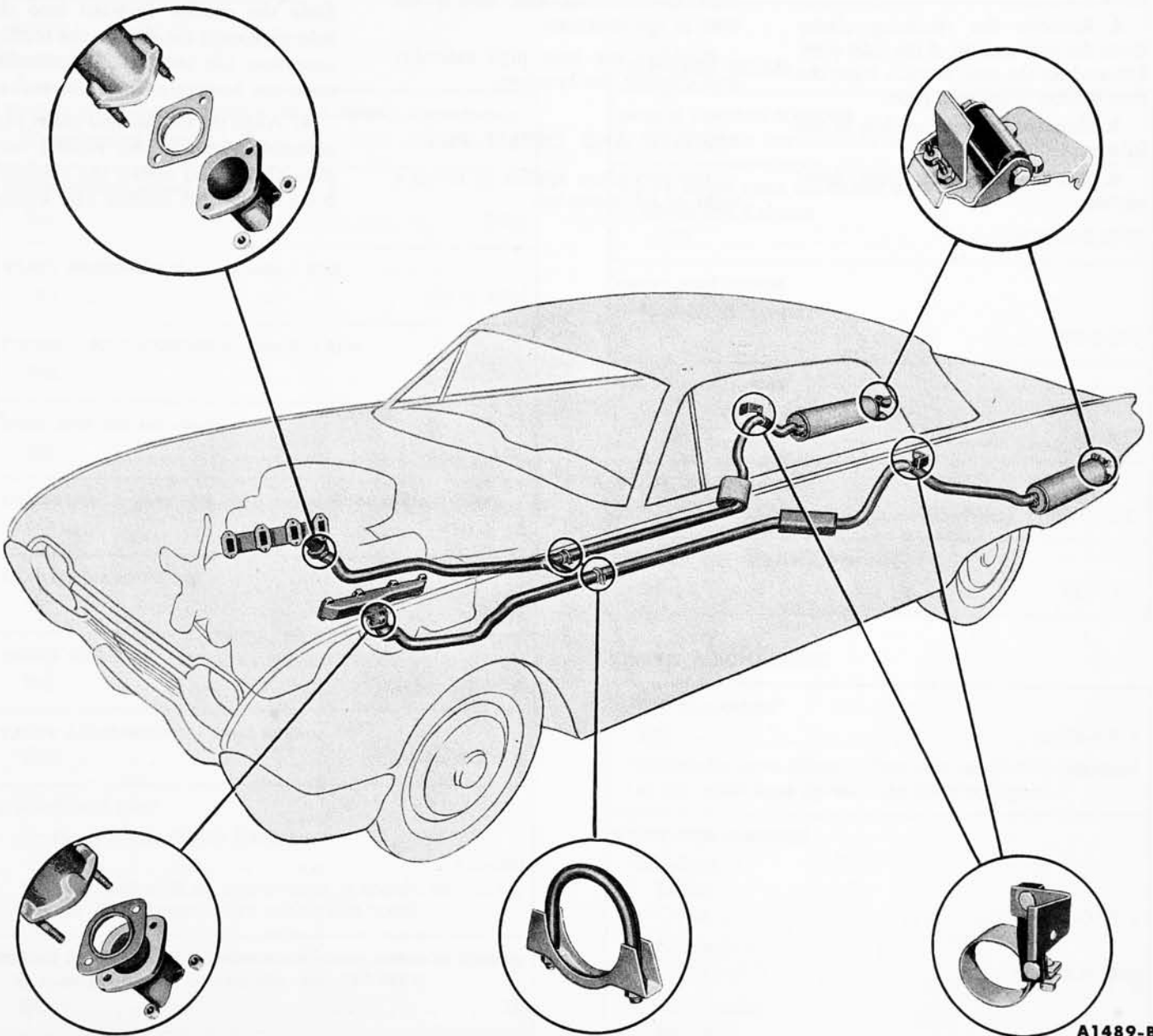
PayPal, American Express, Discover, MasterCard, VISA

# PART

# 1-2

# EXHAUST SYSTEM

Section	Page
1 Description.....	1-41
2 Inlet Pipe, Muffler, and Outlet Pipe Replacement..	1-42



A1489-B

FIG. 1—Exhaust System

**100% SATISFACTION GUARANTEED**

**BUY IT NOW!**

**Click Here To Order**

us  
tel.

PayPal   American Express   Discover   MasterCard   VISA

muffler inlet pipe rear section, and muffler outlet pipe for each exhaust manifold. The right and left muffler

inlet pipe front sections are a one-piece assembly and are serviced as such.

## 2 INLET PIPE, MUFFLER, AND OUTLET PIPE REPLACEMENT

### MUFFLER INLET PIPE

The right and left muffler inlet pipe front sections are serviced as one piece.

1. Loosen the muffler inlet pipe front bracket clamp bolt and slide the clamp from the bracket. Disconnect the inlet pipes at the exhaust manifolds.

2. Remove the retaining clamp from the rear section of the inlet pipe. Disconnect the rear bracket from the rear section of the inlet pipe.

3. Remove the rear section of the inlet pipe.

4. Remove the inlet pipe front section.

5. Position the clamp on the rear section of the new inlet pipe. Connect the front and rear sections. Place a new gasket on the exhaust manifolds.

6. Position the inlet pipe assembly on the exhaust manifold studs and on the extension of the mufflers.

7. Connect the inlet pipe to the exhaust manifolds and torque the nuts to specifications.

8. Align the inlet pipe assembly and connect the brackets.

### MUFFLER AND OUTLET PIPE

The procedure applies to either a right or left assembly.

1. Loosen the muffler inlet pipe rear clamp, then spread the clamp and slide it off the muffler.

2. Remove the lower half of the muffler rear clamp. Remove the muffler from the inlet pipe.

3. Position the new muffler and outlet pipe assembly on the inlet pipe. Slide the muffler forward into the inlet pipe until the slots in the muffler extension are blocked. The overlap must not be greater than 1¼ inches.

4. Align the muffler and outlet pipe assembly. Position the muffler inlet pipe clamp and install the retaining bolts. Install the muffler rear clamp.



# PART 1-3 SPECIFICATIONS

**NOTE: All Specifications are given in inches unless otherwise noted.**

### GENERAL

<b>ENGINE MODELS AND PISTON DISPLACEMENT—Cubic Inches</b> Thunderbird Special V-8.....	390
<b>COMPRESSION RATIO</b> 390.....	9.6:1
<b>BRAKE HORSEPOWER @ Specified RPM</b> 390.....	300 @ 4600
<b>TORQUE—FOOT-POUNDS @ Specified RPM</b> 390.....	427 @ 2800
<b>BORE AND STROKE—Inches</b> 390.....	4.05 x 3.78
<b>COMPRESSION PRESSURE—Sea Level @ CRANKING SPEED</b> 390.....	180 ± 20
<b>TAXABLE HORSEPOWER</b> 390.....	52.49
<b>FIRING ORDER</b> 390.....	1-5-4-2-6-3-7-8
<b>VALVE ARRANGEMENT—Front to Rear</b> 390.....	E-I-E-I-I-E-I-E
<b>ENGINE IDLE RPM*</b> Cruise-O-Matic (Drive Range) 390..... *If equipped with air conditioner, it should be run for at least 20 minutes before setting idle speed.	475-500
<b>ENGINE IDLE MANIFOLD VACUUM—Minimum Inches of Mercury @ Specified Engine Neutral Idle rpm—SEA LEVEL</b> 390.....	18
<b>INITIAL IGNITION TIMING—B.T.D.C.</b> 390—Cruise-O-Matic.....	8°
<b>CRANKCASE OIL CAPACITY*</b> .....	5 quarts oil filter.
.....	35-55

### CYLINDER HEAD

<b>GASKET SURFACE FLATNESS</b> 0.003 inch in any 6 inches or 0.006 inch overall	
<b>VALVE GUIDE BORE STANDARD DIAMETER</b> Intake and Exhaust 390.....	0.3728-0.3735
<b>VALVE SEAT WIDTH</b> Intake and Exhaust 390.....	0.070-0.090
<b>VALVE SEAT ANGLE</b> Intake and Exhaust 390.....	45°
<b>VALVE SEAT RUNOUT</b> 390.....	0.002—Wear Limit 0.0025
<b>COMBUSTION CHAMBER VOLUME—CC</b> 390.....	73.1-76.1

### VALVE MECHANISM

<b>VALVE CLEARANCE*</b> 390.....	0.078-0.218
*Hydraulic valve lifters—Clearance specified is obtained at the valve stem tip with the lifter collapsed.	
<b>VALVE STEM DIAMETER</b> Standard Intake 390.....	0.3711-0.3718
Exhaust 390.....	0.3693-0.3700
<b>0.003 Oversize</b> Intake 390.....	0.3741-0.3748
Exhaust 390.....	0.3723-0.3730
<b>0.015 Oversize</b> Intake 390.....	0.3861-0.3868
Exhaust 390.....	0.3843-0.3850

**100% SATISFACTION GUARANTEED**

**BUY IT NOW!**

**Click Here To Order**

PayPal American Express Discover MasterCard VISA

**VALVE MECHANISM (Continued)**

<b>0.030 Oversize</b>	
<b>Intake</b>	
390.....	0.4011-0.4018
<b>Exhaust</b>	
390.....	0.3993-0.4000
<b>VALVE STEM TO VALVE GUIDE CLEARANCE</b>	
<b>Intake</b>	
390.....	0.0010-0.0024—Wear Limit 0.0045
<b>Exhaust</b>	
390.....	0.0028-0.0042—Wear Limit 0.0055
<b>VALVE HEAD DIAMETER</b>	
<b>Intake</b>	
390.....	2.022-2.037
<b>Exhaust</b>	
390.....	1.551-1.566
<b>VALVE FACE ANGLE</b>	
390.....	44°
<b>INTAKE AND EXHAUST VALVE FACE RUNOUT</b>	
390.....	0.002—Wear Limit 0.0025
<b>VALVE SPRING APPROXIMATE FREE LENGTH</b>	
390.....	2.15
<b>VALVE SPRING MAXIMUM OUT-OF-SQUARE</b>	
390.....	1/16
<b>VALVE SPRING PRESSURE (LBS.) @ SPECIFIED LENGTH</b>	
390.....	74-84 @ 1.820 Wear Limit 67 @ 1.820 190-208 @ 1.420 Wear Limit 171 @ 1.420
<b>VALVE SPRING ASSEMBLED HEIGHT</b>	
390.....	1 13/16-1 27/32
<b>VALVE PUSH ROD RUNOUT</b>	
390.....	0.025
<b>VALVE TAPPET STANDARD DIAMETER</b>	
390.....	0.8740-0.8745
<b>VALVE TAPPET TO TAPPET BORE CLEARANCE</b>	
390.....	0.0005-0.0020
<b>HYDRAULIC VALVE LIFTER LEAK DOWN RATE</b>	
390.....	10-80 Seconds
<b>ROCKER ARM TO ROCKER SHAFT CLEARANCE</b>	
390.....	0.003-0.005—Wear Limit 0.006
<b>ROCKER ARM TO VALVE GUIDE CLEARANCE</b>	
390.....	0.839-0.840
<b>ROCKER ARM TO VALVE GUIDE CLEARANCE</b>	
390.....	0.843-0.844

**CAMSHAFT AND TIMING CHAIN**

<b>CAMSHAFT JOURNAL STANDARD DIAMETER</b>	
390.....	2.1238-2.1248
<b>CAMSHAFT JOURNAL RUNOUT</b>	
390.....	0.005
<b>CAMSHAFT JOURNAL TO BEARING CLEARANCE</b>	
390.....	0.001-0.003—Wear Limit 0.006
<b>TIMING CHAIN DEFLECTION—INCHES</b>	
390.....	0.5
<b>INTAKE AND EXHAUST CAMSHAFT LOBE LIFT</b>	
390.....	0.2316—Wear Limit 0.2266
<b>MAXIMUM ALLOWABLE LOBE LIFT LOSS</b>	
390—Intake and Exhaust.....	0.005

**CAMSHAFT BEARINGS**

<b>INSIDE DIAMETER</b>	
390.....	2.1258-2.1268
<b>LOCATION IN RELATION TO FRONT FACE OF BLOCK CAM BEARING BORE—NO. 1 BEARING ONLY—BELOW</b>	
390.....	0.005-0.020

**CRANKSHAFT**

<b>MAIN BEARING JOURNAL STANDARD DIAMETER</b>	
390 (Coded Red).....	2.7488-2.7492
(Coded Blue).....	2.7484-2.7488
<b>MAIN BEARING JOURNAL MAXIMUM RUNOUT</b>	
390.....	0.002—Wear Limit 0.003
<b>CONNECTING ROD AND MAIN BEARING JOURNALS MAXIMUM OUT-OF-ROUND</b>	
390.....	0.0004—Wear Limit 0.0006
<b>CONNECTING ROD AND MAIN BEARING JOURNALS TAPER</b>	
390.....	0.0003—Wear Limit 0.001
<b>THRUST BEARING JOURNAL LENGTH</b>	
390.....	1.124-1.126
<b>MAIN BEARING JOURNAL THRUST FACE RUNOUT</b>	
390.....	0.001
<b>CONNECTING ROD JOURNAL DIAMETER</b>	
390 (Coded Red).....	2.4384-2.4388
(Coded Blue).....	2.4380-2.4384
<b>CRANKSHAFT FREE END PLAY</b>	
390.....	0.004-0.008—Wear Limit 0.012
<b>ASSEMBLED FLYWHEEL CLUTCH FACE RUNOUT</b>	
390.....	0.010
<b>ASSEMBLED FLYWHEEL RUNOUT</b>	
390.....	0.007
<b>ASSEMBLED SPROCKET OR GEAR FACE RUNOUT</b>	
390.....	0.006

**100% SATISFACTION GUARANTEED**

**BUY IT NOW!**

**Click Here To Order**

PayPal American Express Discover MasterCard VISA

**MAIN BEARINGS**

<b>JOURNAL CLEARANCE</b>	
390.....	0.0006-0.0031—Wear Limit 0.0039

**PISTON PIN**

<b>PISTON PIN DIAMETER</b>	
Standard	
390.....	0.9750-0.9753
0.001 Oversize	
390.....	0.9760-0.9763
0.002 Oversize (Color Coded Yellow)	
390.....	0.9770-0.9773
<b>PISTON PIN LENGTH</b>	
390.....	3.156-3.170
<b>PISTON PIN TO PISTON CLEARANCE</b>	
390.....	0.0001-0.0003—Wear Limit 0.0008
<b>PISTON PIN TO CONNECTING ROD BUSHING CLEARANCE</b>	
390.....	0.0001-0.0005—Wear Limit 0.001

**CONNECTING ROD**

<b>PISTON PIN BORE OR BUSHING—INSIDE DIAMETER</b>	
Standard	
390.....	0.9752-0.9755
<b>PISTON PIN BUSHING MAXIMUM OUT-OF-ROUND</b>	
390.....	0.0004
<b>PISTON PIN BUSHING MAXIMUM TAPER</b>	
390.....	0.0003
<b>BEARING BORE DIAMETER</b>	
390 (Coded Red).....	2.5907-2.5911
(Coded Blue).....	2.5911-2.5915
<b>BEARING BORE MAXIMUM OUT-OF-ROUND AND TAPER</b>	
390.....	0.0004
<b>CONNECTING ROD CENTER-TO-CENTER LENGTH</b>	
390.....	6.486-6.490
<b>CONNECTING ROD</b>	
Twist Total Difference—Maximum	
390.....	0.012
Bend Total Difference—Maximum	
390.....	0.004
<b>CONNECTING ROD ASSEMBLY—Assembled to crankshaft</b>	
Side Clearance	
390.....	0.006-0.016—Wear Limit 0.019

**PISTON RINGS**

<b>RING WIDTH</b>	
Upper Compression Ring	
390.....	0.0774-0.0781
Lower Compression Ring	
390.....	0.0930-0.0940
<b>SIDE CLEARANCE</b>	
Upper Compression Ring	
390.....	0.0024-0.0041—Wear Limit 0.006
Lower Compression Ring	
390.....	0.002-0.004—Wear Limit 0.006
Oil Ring	
390.....	Snug
<b>RING GAP WIDTH</b>	
Compression Ring (Standard Bore—Upper and Lower)	
390.....	0.015-0.025
Oil Ring (Standard Bore)*	
390.....	0.015-0.055

\*Steel rail

**CONNECTING ROD BEARINGS**

<b>BEARING TO CRANKSHAFT CLEARANCE</b>	
390.....	0.0007-0.0028—Wear Limit 0.0038

**PISTON**

<b>PISTON DIAMETER</b>	
Red Color Code	
390.....	4.0477-4.0483
Blue Color Code	
390.....	4.0489-4.0495
Oversize	
390.....	4.0501-4.0507
<b>BOTTOM OF SKIRT</b>	
390.....	Wear Limit 0.006

**CYLINDER BLOCK**

<b>CYLINDER BORE DIAMETER (Standard, spread for 8 grades)</b>	
390.....	4.0500-4.0524
<b>CYLINDER BORE MAXIMUM OUT-OF-ROUND</b>	
390.....	0.001—Wear Limit 0.003
<b>CYLINDER BORE TAPER</b>	
390.....	0.001—Wear Limit 0.005
<b>HEAD GASKET SURFACE FLATNESS</b>	
390.....	0.003 inch in any 6 inches or 0.006 inch overall

**OIL PUMP**

<b>RELIEF VALVE SPRING TENSION—LBS. @ SPECIFIED LENGTH</b>	
390.....	9.0-9.6 .. 1.53 inches
<b>RELIEF VALVE CLEARANCE</b>	
390.....	0.0015-0.0029
<b>DRIVE SHAFT TO HOUSING BEARING CLEARANCE</b>	
390.....	0.0015-0.0029
<b>ROTOR ASSEMBLY END CLEARANCE—PUMP ASSEMBLED</b>	
390.....	0.0011-0.0041
<b>OUTER RACE TO HOUSING—RADIAL CLEARANCE</b>	
390.....	0.006-0.012
<b>DRIVE SHAFT LENGTH—ROTOR ASSEMBLY FACE TO SHAFT END</b>	
390.....	2.24-2.26

**TORQUE LIMITS (ft-lbs)**

<b>MAIN BEARING CAP BOLTS—OILED THREADS</b>	
390.....	95-105
<b>CYLINDER HEAD BOLTS—OILED THREADS</b>	
390.....	80-90
<b>OIL PAN TO CYLINDER BLOCK</b>	
390.....	9-13
<b>MANIFOLDS TO CYLINDER HEAD</b>	
<b>Intake</b>	
390.....	32-35
<b>Exhaust</b>	
390.....	12-18
<b>FLYWHEEL TO CRANKSHAFT</b>	
390.....	75-85
<b>OIL PUMP TO CYLINDER BLOCK</b>	
390.....	23-28
<b>OIL PUMP COVER PLATE</b>	
390.....	6-9
<b>OIL FILTER ANGLE ADAPTER TO CYLINDER BLOCK</b>	
390.....	12-15

**TORQUE LIMITS (ft-lbs) (Continued)**

<b>CYLINDER FRONT COVER</b>	
390.....	12-15
<b>WATER OUTLET HOUSING</b>	
390.....	12-15
<b>WATER PUMP TO CYLINDER BLOCK OR FRONT COVER</b>	
390.....	23-28
<b>CAMSHAFT SPROCKET TO CAMSHAFT</b>	
390.....	35-45
<b>DAMPER OR PULLEY TO CRANKSHAFT</b>	
390.....	70-90
<b>CONNECTING ROD NUTS</b>	
390.....	40-45
<b>VALVE ROCKER ARM COVER</b>	
390.....	4-7
<b>VALVE ROCKER SHAFT SUPPORT TO CYLINDER HEAD</b>	
390.....	40-45
<b>OIL PICK-UP TUBE TO OIL PUMP</b>	
390.....	12-15
<b>FUEL PUMP TO CYLINDER BLOCK OR CYLINDER FRONT COVER</b>	
390.....	23-28
<b>ENGINE SUPPORT</b>	
<b>Front Insulator to Engine</b>	
390.....	35-40
<b>Front Insulator to Intermediate Bracket</b>	
390.....	30-42
<b>Intermediate Bracket to Cross Member</b>	
390.....	30-42
<b>Support Retainer to Extension Housing</b>	
390.....	25-30
<b>Support to End Bracket</b>	
390.....	30-42

**STANDARD TORQUE LIMITS FOR VARIOUS SIZE BOLTS**

**CAUTION:** Special torque limits listed in the preceding tables should be used in preference to these standard limits wherever they apply.



**BUY IT NOW!**

**Click Here To Order**

	1/4-20	1/4-28	5/16-18	5/16-24	3/8-16	3/8-24
	6-9	6-9	12-15	15-18	23-28	30-35
	7/16-14	7/16-20	1/2-13	1/2-20	9/16-18	5/8-18
	45-50	50-60	60-70	70-80	85-95	130-145



# 1962 FORD THUNDERBIRD SHOP MANUAL

## GROUP 2

# IGNITION SYSTEM

	PAGE
<b>PART 2-1</b> IGNITION SYSTEM MAINTENANCE.....	2-2
<b>PART 2-2</b> DISTRIBUTOR.....	2-11
<b>PART 2-3</b> SPECIFICATIONS.....	2-16



**BUY IT NOW!**

**Click Here To Order**



FORD DIVISION • FORD MOTOR COMPANY



**BUY IT NOW!**

**Click Here To Order**



PayPal

Discover  
Cards

DISCOVER  
NEWUS

MasterCard

VISA

FORD MOTOR COMPANY

LITHO IN U.S.A.