

**1959**

**FORD  
TRUCK**

**SHOP  
MANUAL**

**BUY IT NOW!**

**Click Here To Order**



PayPal

Discover  
Cards

AMERICAN  
EXPRESS

MasterCard

VISA

**FORD DIVISION  
FORD MOTOR COMPANY**

Copyright © 2011, Forel Publishing Company, LLC, Woodbridge, Virginia

All Rights Reserved. No part of this book may be used or reproduced in any manner whatsoever without written permission of Forel Publishing Company, LLC. For information write to Forel Publishing Company, LLC, 3999 Peregrine Ridge Ct., Woodbridge, VA 22192

## **1959 Ford Truck Shop Manual**

**EAN: 978-1-60371-068-8**

**ISBN: 1-60371-068-X**

Forel Publishing Company, LLC

3999 Peregrine Ridge Ct.

Woodbridge, VA 22192

Email address: [sales@ForelPublishing.com](mailto:sales@ForelPublishing.com)

Website: <http://www.ForelPublishing.com>



This publication contains material that is reproduced and distributed under a license from Ford Motor Company. No further reproduction or distribution of the Ford Motor Company material is allowed without the express written permission of Ford Motor Company.

---

## **Note from the Publisher**

This product was created from the original Ford Motor Company's publication. Every effort has been made to use the original scanned images, however, due to the condition of the material; some pages have been modified to remove imperfections.

---

## **Disclaimer**

Although every effort was made to ensure the accuracy of this book, no representations or warranties of any kind are made concerning the accuracy, completeness or suitability of the information, either expressed or implied. As a result, the information contained within this book should be used as general information only. The author and Forel Publishing Company, LLC shall have neither liability nor responsibility to any person or entity with respect to any loss or damage caused, or alleged to be caused, directly or indirectly by the information contained in this book. Further, the publisher and author are not engaged in rendering legal or other

advice, mechanical, electrical, or other expert assistance is required, the professional should be sought.



# 1959

# FORD TRUCK

# SHOP MANUAL

## INDEX

ENGINES	1
IGNITION, FUEL, AND COOLING SYSTEMS	2
CLUTCHES AND MANUAL-SHIFT TRANSMISSIONS	3
FORDOMATIC AND HEAVY DUTY CRUISE-O-MATIC TRANSMISSIONS	4
TRANSMATIC DRIVE TRANSMISSION	5
REAR AXLE AND 4-WHEEL DRIVE FRONT AXLE	6
WHEELS, TIRES, CHASSIS SUSPENSION, AND FRAMES	7
STEERING	8
BRAKES	9
GENERATING AND STARTING SYSTEMS	10
LIGHTS, INSTRUMENTS, AND ACCESSORIES	11
BODY MAINTENANCE AND REPAIR	12
DOORS, CABS, AND FRONT SHEET METAL	13
INTERIOR TRIM, SEATS, AND WINDOWS	14
MAINTENANCE, LUBRICATION, AND SPECIAL TOOLS	15



**BUY IT NOW!**

**Click Here To Order**



DEPARTMENT  
DIVISION  
FOR COMPANY



COMPANY, DEARBORN, MICHIGAN

## FOREWORD

*This manual provides information for the proper servicing of 1959 Ford Trucks. Service procedures for the Courier and Ranchero are covered in the 1959 Ford Car Shop Manual. The descriptions and specifications contained in this manual were in effect at the time the manual was approved for printing. The Ford Division of Ford Motor Company reserves the right to discontinue models at any time, or change specifications or design, without notice and without incurring obligation.*

SERVICE DEPARTMENT  
**FORD DIVISION**  
FORD MOTOR COMPANY

© 1958 FORD MOTOR COMPANY, DEARBORN, MICHIGAN

**100% SATISFACTION GUARANTEED**

**BUY IT NOW!**

**Click Here To Order**

PayPal American Express Discover MasterCard VISA

# 1959 FORD TRUCK SHOP MANUAL

## GROUP I ENGINES

	PAGE
<b>PART 1-1</b> GENERAL ENGINE SERVICE.....	1-2
<b>PART 1-2</b> 223 SIX ENGINE.....	1-20
<b>PART 1-3</b> MEDIUM AND HEAVY DUTY V-8 ENGINES.....	1-42
<b>PART 1-4</b> SUPER DUTY V-8 ENGINES.....	1-73
<b>PART 1-5</b> SPECIFICATIONS.....	1-101



**BUY IT NOW!**

**Click Here To Order**

PayPal

MasterCard

DISCOVER  
PLUS

MasterCard

VISA

## PART

## 1-1

## GENERAL ENGINE SERVICE

Section	Page	Section	Page
1 Engine Trouble Diagnosis .....	1-2	4 Timing Chain, Timing Gears, Camshaft, and Bearings .....	1-12
2 Tune-up .....	1-5	5 Flywheel, Crankshaft, Connecting Rods, Piston Assemblies, and Bearings .....	1-14
3 Manifolds, Cylinder Heads, and Valves .....	1-7		

Section	Page
6 Cylinder Block .....	1-18
7 Oil Pan, Oil Pump, and Oil Cooler .....	1-19

The V-8 engines will be referred to as follows: medium duty engine (292 cubic inch displacement) as MD V-8; heavy duty engines (292, 302, and 332 cubic inch displacement) as HD V-8; and super duty engines (401, 477, and 534 cubic inch displacement) as SD V-8.

The following service procedures apply to all engines. The cleaning, inspection, repair, and overhaul procedures of the component engine parts apply after the parts have been

removed from the engine, or in the case of a complete engine overhaul, after the engine has been disassembled.

For removal, disassembly, and

installation procedures, refer to Part 1-2, 1-3, or 1-4.

The specifications for all engines are listed in Part 1-5.

## 1 ENGINE TROUBLE DIAGNOSIS

Poor engine performance can be caused by the need for a general engine tune-up, by gradual wear of engine parts or by a sudden parts failure. A good trouble diagnosis will indicate the need of a complete engine tune-up, individual adjustments, part(s) replacement or overhaul, or the need of a complete engine overhaul.

Engine performance complaints fall under one of the basic categories listed in the "Engine Trou-

each check refers to that part of the manual which covers, in detail, checking procedures as well as corrections to be made in the various systems. When a particular trouble can not be traced to a definite system by a simple check, the possible systems that could be at fault are listed in the order of their probable occurrence; therefore, in most cases, the checks should be made in the order listed. Some consideration, however, should be given to logical order. For example, if the spark plugs are removed for testing and they are not the cause of the trouble, and several checks later calls for a compression test, to save time, check the compression before the spark plugs are out.

A separate "Trouble Diagnosis Guide" is included in the ignition, fuel, and cooling system parts of the manual. These diagnosis guides list the basic troubles listed in the "Engine Trouble Diagnosis Guide", but cover only the items relating to the particular system under consideration. For example, in the "Engine Trouble Diagnosis Guide" under Poor Acceleration, the ignition system is listed as a probable cause of the trouble. In the Ignition Trouble Diagnosis Guide under Poor Acceleration, all the ignition system items that affect acceleration are listed. These items should all be checked before proceeding to the next item listed in the "Engine Trouble Diagnosis Guide."

**100% SATISFACTION GUARANTEED**

**BUY IT NOW!**

**Click Here To Order**

PayPal American Express Discover Novus MasterCard VISA

## ENGINE TROUBLE DIAGNOSIS GUIDE

<p><b>ENGINE WILL NOT CRANK</b></p>	<p>The cause of this trouble is usually in the starting system (Part 10-2). If the starting system is not at fault, check for a hydrostatic lock or a seized engine. Remove the spark plugs, then attempt to crank the engine with the starter. If the engine</p>	<p>cranks, it indicates that water is leaking into the cylinders. Remove the cylinder head(s) and inspect the gasket(s) and/or head(s) for cracks. Also examine the cylinder block for cracks.</p>
<p><b>ENGINE CRANKS NORMALLY, BUT WILL NOT START</b></p>	<p>Check the fuel supply. If there is sufficient fuel in the tank, the cause of the trouble probably lies in either the ignition or the fuel system. To isolate the cause: Remove the ignition wire from a spark plug, and insert a piece of proper sized metal rod in the insulator so that it protrudes from the insulator. With the ignition on and the starter cranking the engine, hold the end of the rod approximately <math>\frac{3}{16}</math></p>	<p>inch from the cylinder block. If there is no spark or a weak spark, the cause of the trouble is in the ignition system (Part 2-1). If the spark is good, check the spark plugs (Part 2-1). If the spark plugs are not at fault, check the fuel system (Part 2-2). If the fuel system is not at fault, check the valve timing (Part 1-2, 1-3, or 1-4).</p>
<p><b>ENGINE STARTS, BUT FAILS TO KEEP RUNNING</b></p>	<p>If the engine starts and runs for a few seconds, then stops, check the: Fuel system (Part 2-2). Ignition system (Part 2-1).</p>	<p>No oil pressure (on trucks with an electric fuel pump the safety switch would automatically shut off the electric fuel pump).</p>
<p><b>ENGINE RUNS, BUT MISSES</b></p>	<p>First, determine if the miss is steady or erratic and at what speed the miss occurs by operating the engine at various speeds under load. <b>MISSES STEADILY AT ALL SPEEDS</b> Isolate the miss by operating the engine with one cylinder not firing. This is done by operating the engine with the ignition wire removed from one spark plug at a time, until all cylinders have been checked. Ground the spark plug wire removed. If the engine speed changes when a particular cylinder is shorted out, that cylinder was delivering power before being shorted out. If no change in the engine operation is evident, the miss was caused by that cylinder not delivering power before being shorted out. Check the: Ignition system Engine compression</p>	<p><b>MISSES ERRATICALLY AT ALL SPEEDS</b> Check the: Exhaust gas control valve (Part 1-1). Ignition system (Part 2-1). Fuel system (Part 2-2). Engine compression to determine which mechanical component of the engine is at fault (Part 1-1). Exhaust system for excessive back pressure. Cooling system for internal leaks and/or for a condition that prevents the engine from reaching normal operating temperature (Part 2-4).</p>



**BUY IT NOW!**

**Click Here To Order**



CONTINUED ON NEXT PAGE

## ENGINE TROUBLE DIAGNOSIS GUIDE (Cont.)

<p><b>ENGINE RUNS, BUT MISSES (Cont.)</b></p>	<p><b>MISSES AT IDLE ONLY</b></p> <p>Check the:</p> <ul style="list-style-type: none"> <li>Fuel system (Part 2-2).</li> <li>Ignition system (Part 2-1).</li> <li>Vacuum booster pump, lines, and fittings for leaks (223 Six only).</li> <li>Valve lash (Part 1-2, 1-3, or 1-4).</li> <li>Engine compression for low compression (Part 1-1).</li> </ul>	<p><b>MISSES AT HIGH SPEED ONLY</b></p> <p>Check the:</p> <ul style="list-style-type: none"> <li>Ignition system (Part 2-1).</li> <li>Fuel System (Part 2-2).</li> <li>Cooling system for overheating or internal leakage (Part 2-4).</li> </ul>
<p><b>ROUGH ENGINE IDLE</b></p>	<p>Check the:</p> <ul style="list-style-type: none"> <li>Fuel system (Part 2-2).</li> <li>Ignition system (Part 2-1).</li> <li>Exhaust gas control valve (Part 1-1).</li> <li>Valve lash (Part 1-2, 1-3, or 1-4).</li> <li>Vacuum booster pump, lines,</li> </ul>	<ul style="list-style-type: none"> <li>and fittings for leaks (223 Six only).</li> <li>Loose engine mounts (Part 1-2, 1-3, or 1-4).</li> <li>Improper cylinder head bolt torque (Part 1-2, 1-3, or 1-4).</li> <li>Leaking power brake vacuum booster (Part 9-2).</li> </ul>
<p><b>POOR ACCELERATION</b></p>	<p>Check the:</p> <ul style="list-style-type: none"> <li>Ignition system (Part 2-1).</li> <li>Fuel system (Part 2-2).</li> <li>Exhaust gas control valve (Part 1-1).</li> <li>Valve lash (Part 1-2, 1-3, or 1-4).</li> </ul>	<ul style="list-style-type: none"> <li>Brakes for proper adjustment (Group 9).</li> <li>Clutch slippage (Manual-Shift Transmission).</li> <li>Automatic transmission for proper adjustment.</li> </ul>
<p><b>ENGINE DOES NOT DEVELOP FULL POWER, OR HAS POOR HIGH SPEED PERFORMANCE</b></p>	<p>Determine if the trouble exists when the engine is cold, at normal operating temperature, or at all engine temperatures.</p> <p><b>ENGINE COLD</b></p> <p>Check the:</p> <ul style="list-style-type: none"> <li>Exhaust gas control valve (Part 1-1).</li> <li>Fuel system (Part 2-2).</li> <li>Cooling system if the engine reaches operating temperature slowly (Part 2-3).</li> </ul> <p><b>ENGINE AT NORMAL OPERATING TEMPERATURE</b></p> <p>Check the:</p> <ul style="list-style-type: none"> <li>Exhaust gas control valve (Part 1-1).</li> <li>Fuel system (Part 2-2).</li> </ul>	<p><b>ALL ENGINE TEMPERATURES</b></p> <p>Check the:</p> <ul style="list-style-type: none"> <li>Engine compression (Part 1-1).</li> <li>Ignition system (Part 2-1).</li> <li>Fuel system (Part 2-2).</li> <li>Governor (Part 2-3).</li> <li>Valve lash (Part 1-2, 1-3, or 1-4).</li> <li>Camshaft lobe lift (Part 1-1).</li> <li>Valve timing (Part 1-2, 1-3, or 1-4).</li> <li>Cooling system if the engine overheats (Part 2-3).</li> <li>Exhaust system for excessive back pressure.</li> <li>Torque converter (Automatic Transmission).</li> <li>Brake adjustment.</li> <li>Tire pressure (Part 7-3).</li> </ul>



**BUY IT NOW!**

**Click Here To Order**



ENGINE TROUBLE DIAGNOSIS GUIDE (Cont.)

<p><b>EXCESSIVE FUEL CONSUMPTION</b></p>	<p>Determine the actual fuel consumption with test equipment installed in the truck.</p> <p>If the test indicates that the fuel consumption is not excessive, demonstrate to the owner how improper driving habits will affect fuel consumption.</p> <p>If the test indicates that the fuel consumption is excessive, make the preliminary checks listed below before proceeding to the fuel and ignition systems.</p> <p><b>PRELIMINARY CHECKS</b></p> <p>Tires (Part 7-3). Wheel alignment (Part 7-3). Brakes.</p>	<p>Exhaust gas control valve (Part 1-2, 1-3, or 1-4). Odometer calibration (Part 11-1). Ignition timing (Part 2-1). Valve lash (Part 1-2, 1-3, or 1-4).</p> <p><b>FUEL SYSTEM</b> (Part 2-2.)</p> <p><b>IGNITION SYSTEM</b> (Part 2-1.)</p> <p><b>ENGINE COMPRESSION</b> (Part 1-1.)</p> <p><b>COOLING SYSTEM</b> (Part 2-4.)</p> <p><b>TORQUE CONVERTER</b></p>
<p><b>ENGINE OVERHEATS</b></p>	<p>Temperature sending unit (Part 11-1). Temperature gauge (Part 11-1). Exhaust gas control valve (Part 1-1). Cylinder head bolt torque (Part 1-2, 1-3, or 1-4).</p>	<p>Cooling system (Part 2-4). Ignition timing (Part 2-1). Valves (Part 1-1). Exhaust system. Brakes.</p>
<p><b>ENGINE FAILS TO REACH NORMAL OPERATING TEMPERATURE</b></p>	<p>Temperature sending unit (Part 11-1). Temperature gauge (Part 11-1).</p>	<p>Engine thermostat(s) (Part 2-4).</p>

**2 TUNE-UP**

is a systematic procedure...  
d...  
pe...  
tions...  
perfo...

The Tune-Up Schedule (Table 1) is applicable for either a minor or major tune-up. A minor tune-up is recommended every 8000 miles and a major tune-up is recommended every 16,000 miles. The reference after

each operation refers to that part of the manual which describes, in detail, the procedure to be followed. Perform the operations in the sequence listed.

**100% SATISFACTION GUARANTEED**

**BUY IT NOW!**

**Click Here To Order**

PayPal American Express Discover MasterCard VISA

TABLE 1—Tune-Up Schedule

Operation	Perform on		Recommended Procedure
	Minor	Major	
<b>SPARK PLUGS</b> Clean, adjust, and test.	X	X	Part 2-1
<b>ENGINE COMPRESSION</b> Take compression reading of each cylinder.		X	Part 1-1
<b>INTAKE MANIFOLD</b> Check and tighten bolts.		X	Part 1-2, 1-3, or 1-4
<b>DRIVE BELTS</b> Check and adjust the tension of all drive belts.	X	X	Part 2-4
<b>BATTERY</b> Clean battery cables and terminals.		X	Part 10-1
Tighten cable clamps.		X	
Grease battery terminals.		X	
Check battery state of charge.	X	X	
<b>ELECTRICAL</b> Oil generator rear bearing through oil cup (223 Six).		X	Part 10-1
Check generator output.		X	
Check starter motor current draw.		X	
Check coil output.		X	Part 2-1
Perform a primary circuit resistance test.		X	
Perform a secondary circuit continuity test.		X	
<b>DISTRIBUTOR</b> Check the condition of the breaker points.	X		Part 2-1
Replace the breaker points and the condenser.		X	
Check and adjust the breaker arm spring tension.		X	
Lubricate the distributor cam. Oil the lubricating wick (Centrifugal Advance and Dual Advance Distributors).			

Operation	Perform on		Recommended Procedure
	Minor	Major	
<b>DISTRIBUTOR (Cont'd)</b> Check and adjust centrifugal advance (Centrifugal Advance and Dual Advance Distributors).		X	Part 2-1
Check and adjust vacuum advance (Loadomatic and Dual Advance Distributors).		X	
Clean distributor cap and rotor.	X	X	
<b>FUEL SYSTEM</b> Clean fuel pump filter bowl.	X	X	Part 2-2
Replace fuel pump filter bowl strainer.		X	
Check fuel pump pressure and capacity.		X	
Drain fuel system filter.	X		
Replace fuel system filter element.		X	
Clean carburetor fuel bowl(s) and adjust float setting.		X	
<b>ADJUSTMENTS</b> Check and adjust ignition timing.	X	X	Part 2-1
Check and adjust engine idle speed.	X	X	Part 2-2
Adjust idle fuel mixture.	X	X	
Check and adjust valve lash.		X	Part 1-2, 1-3, or 1-4
Check and adjust governor speed.	X	X	Part 2-3
<b>EXHAUST</b> Free the exhaust gas control valve.	X	X	Part 1-1
<b>COOLING SYSTEM</b> Inspect the radiator, hoses, and engine for water leaks.		X	Part 2-4
Add rust inhibitor to radiator.		X	



**BUY IT NOW!**

**Click Here To Order**



**MANIFOLD VACUUM TEST**

A manifold vacuum test aids in determining the condition of an engine and also in helping to locate the cause of poor engine performance. To test manifold vacuum:

1. Operate the engine for a minimum of ½-hour at 1200 rpm.

2. Install an accurate, sensitive vacuum gauge on the manifold vacuum line or on the fitting in the intake manifold.

3. Operate the engine at recommended idle rpm.

4. Check the vacuum reading on the gauge.

**TEST CONCLUSIONS**

Manifold vacuum is affected by carburetor adjustment, valve timing, the condition of the valves, cylinder compression, and leakage of the intake manifold, carburetor, or cylinder head gaskets.

Because abnormal gauge readings may indicate that more than one of the above factors is at fault, exercise caution in analyzing an abnormal reading. For example, if the vacuum is low, the correction of one item may increase the vacuum enough to indicate that the trouble has been corrected. It is important, therefore, that each cause of an abnormal reading be investigated and further tests conducted where necessary in order to arrive at the correct diagnosis of the trouble.

Table 2 lists various types of readings and their possible causes.

Allowance should be made for the effect of altitude on the gauge reading. The engine vacuum will decrease with an increase in altitude.

**ENGINE COMPRESSION TEST**

1. Be sure the battery is good. Operate the engine for a minimum of ½ hour at 1200 rpm. Turn the ignition switch off, then remove all the spark plugs.

2. Set the throttle plates (primary throttle plates only on the 4-barrel carburetor) and choke plate in the wide open position.

3. Install a compression gauge in No. 1 cylinder.

**TABLE 2—Manifold Vacuum Gauge Readings**

Gauge Reading (Inches Hg.)	Engine Condition
16-17 (401 SD V-8) 17-18 (447, 534 SD V-8) 18-19 (223 Six and 302, 332 HD V-8) 19-20 (292 MD and HD V-8)	Normal.
Low and steady.	Loss of power in all cylinders caused possibly by late ignition or valve timing, or loss of compression due to leakage around the piston rings.
Very low.	Manifold, carburetor, or cylinder head gasket leak.
Needle fluctuates steadily as speed increases.	A partial or complete loss of power in one or more cylinders caused by: a leaking valve; cylinder head or intake manifold gasket leak; a defect in the ignition system; or a weak valve spring.
Gradual drop in reading at engine idle.	Excessive back pressure in the exhaust system.
Intermittent fluctuation.	An occasional loss of power possibly caused by a defect in the ignition system or a sticking valve.
Slow fluctuation or drifting of the needle.	Improper idle mixture adjustment, carburetor or intake manifold gasket leak, or possibly late valve timing.

4. Crank the engine several times and record the highest reading recorded. Note the number of compression strokes required to obtain the highest reading.

5. Repeat the test on each cylinder, cranking the engine the same number of times for each cylinder as was required to obtain the highest reading on No. 1 cylinder.

**TEST CONCLUSIONS**

A variation of  $\pm 20$  pounds (SD V-8 engines) or  $\pm 10$  pounds (223 Six and all MD and HD V-8 engines) from specified pressure is satisfactory. However, the compression of all cylinders should be uniform within 10 pounds.

A reading of more than the allowable tolerance above normal indicates excessive deposits in the cylinder.

A reading of more than the allowable tolerance below normal indicates leakage at the cylinder head gasket, piston rings, or valves.

A low even compression in two adjacent cylinders indicates a cylinder head gasket leak. This should be checked before condemning the rings or valves.

To determine whether the rings or the valves are at fault, squirt the equivalent of a tablespoon of heavy oil into the combustion chamber, then crank the engine to distribute the oil and repeat the compression test. The oil will temporarily seal leakage past the rings. If approximately the same reading is obtained, the rings are satisfactory, but the valves are leaking. If the compression has increased 10 pounds or more over the original reading, there is leakage past the rings.

During a compression test, if the pressure fails to climb steadily and remains the same during the first two successive strokes, but climbs higher on the succeeding strokes, or fails to climb during the entire test, it indicates a sticking valve.

**HEADS, AND VALVES**

the intake manifolds for all engines except the SD V-8 engines, all carbon deposits from the exhaust passage below the car-

buretor heat riser of the intake manifold. This carbon acts as an insulator restricting the heating action of the hot exhaust gases.

**100% SATISFACTION GUARANTEED**

**BUY IT NOW!**

**Click Here To Order**

PayPal American Express Discover MasterCard VISA

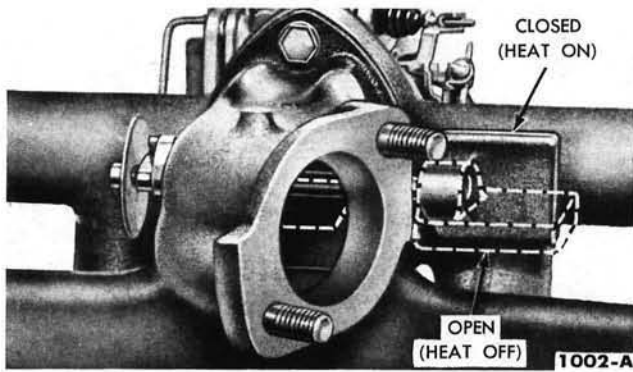


FIG. 1—Exhaust Gas Control Valve—223 Six

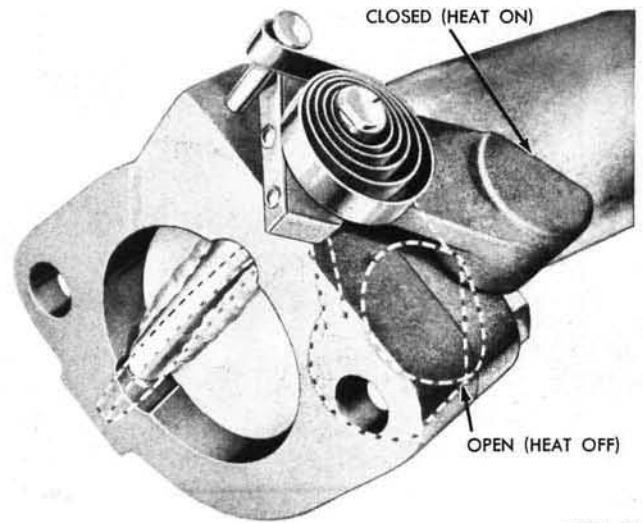


FIG. 2—Exhaust Gas Control Valve—292 MD V-8

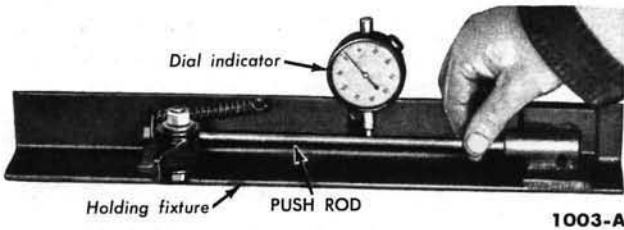


FIG. 3—Push Rod Runout—Typical

Inspect the manifolds for cracks, leaks, or other defects that would make them unfit for further service. Replace all studs that are stripped or otherwise damaged. **Remove all filings and foreign matter that may have entered the manifolds as a result of repairs.**

**EXHAUST GAS CONTROL VALVE—223 SIX AND 292 MD V-8**

Check the thermostatic spring to make sure it is hooked on the stop pin. The spring stop is at the top of the valve housing when the valve is properly installed. The action of the valve is illustrated in Fig. 1 or 2.

Check to make sure the spring holds the valve closed when the engine is cold. Actuate the counterweight by hand to make sure it moves freely through approximately 90° of rotation without binding.

The valve is closed when the engine is at normal operating temperature running at idle speed. How-

temperature and is operated at high rpm. Free stuck valves with a penetrating oil and graphite mixture.

**VALVE ROCKER ARM SHAFT ASSEMBLY**

Clean all the parts thoroughly. Make sure that all oil passages are open.

Check the clearance between each rocker arm and the shaft by checking the I.D. of the rocker arm bore and the O.D. of the shaft. If the clearance between any rocker arm and the shaft exceeds the wear limit, replace the shaft and/or the rocker arm. Inspect the shaft and the rocker arm bore for nicks, scratches, scores, or scuffs. Dress up minor surface defects with a hone.

Inspect the pad at the valve end of the rocker arms for a grooved radius. If the pad is grooved, replace the rocker arm. **Do not attempt to true its surface by grinding.**

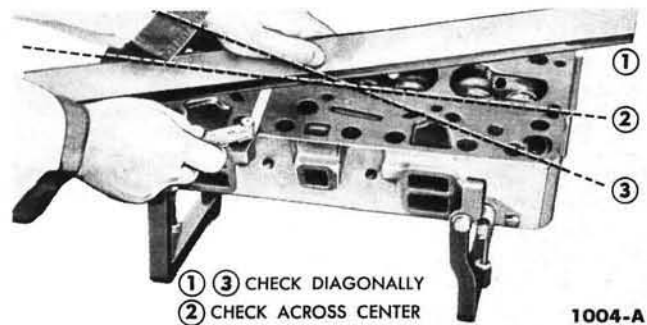


FIG. 4—Cylinder Head Flatness—Typical

Check the rocker arm adjusting screws and the push rod end of the rocker arms for stripped or broken threads, and the ball end of the adjusting screw for nicks, scratches, or excessive wear.

Check for broken locating springs. Inspect the oil tubes (except SD V-8 engines) for cracks or sharp bends.

**PUSH RODS**

Check the ball end and the socket end of the push rods for nicks, grooves, roughness, or excessive wear.

The push rods can be visually checked for straightness while they are installed in the engine by rotating them with the valve closed. They also can be checked between ball and cup centers with a dial indicator (Fig. 3). If the runout exceeds the maximum limit at any point, discard the rod. **Do not attempt to straighten push rods.**

**100% SATISFACTION GUARANTEED**

**BUY IT NOW!**

**Click Here To Order**

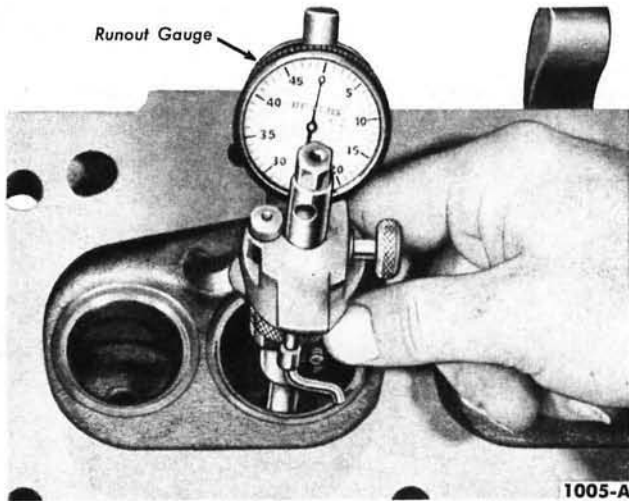


FIG. 5—Valve Seat Runout—Typical

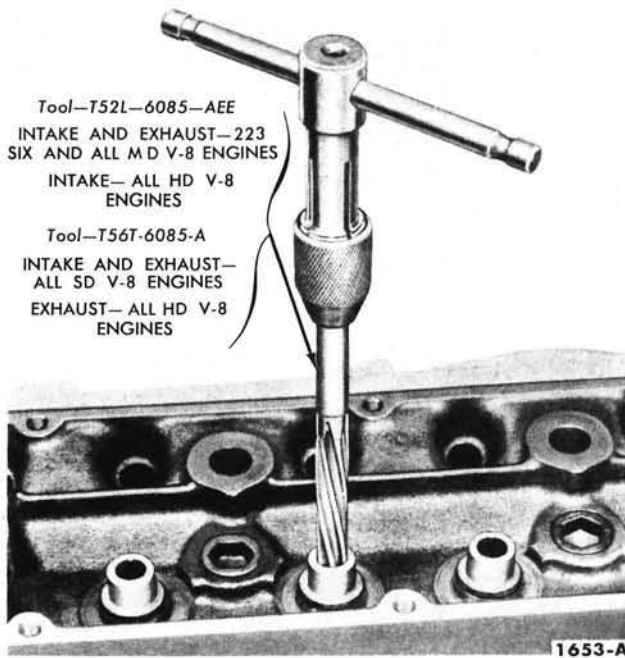


FIG. 7—Reaming Valve Guides—Typical

### CYLINDER HEADS

To protect the machined surfaces of the cylinder head, use holding fixtures while the head is off the engine.

### INSPECTION

Check the head for cracks, and the gasket surface for burrs and nicks. Replace the head if it is cracked. Do not plane or grind more than 0.010 inch from the cylinder gasket surface. Remove all burrs or scratches with an oil stone.

Check the valve seat insert for excessive wear, cracks, or scoring (intake and exhaust on 302

the valve guide bores with a valve guide cleaning tool. Use cleaning solvent to remove dirt and grease.

Check the head for cracks, and the gasket surface for burrs and nicks. Replace the head if it is cracked. Do not plane or grind more than 0.010 inch from the cylinder gasket surface. Remove all burrs or scratches with an oil stone. Check the valve seat insert for excessive wear, cracks, or scoring (intake and exhaust on 302

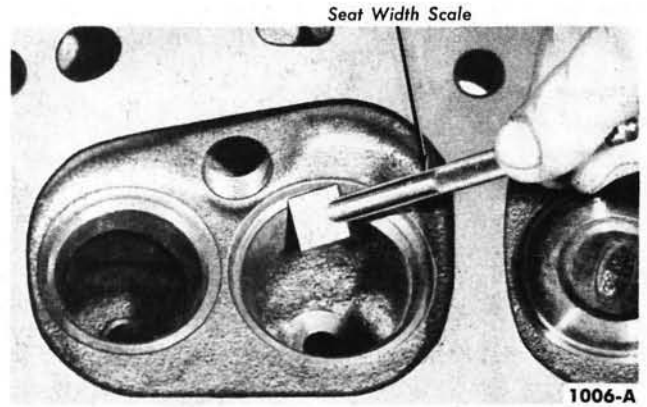


FIG. 6—Valve Seat Width—Typical

and 332 HD V-8 and all SD V-8 engines, exhaust only on 292 HD V-8 engines).

**Cylinder Head Flatness.** Check the flatness of the cylinder head gasket surface (Fig. 4). Specifications for flatness are 0.006 inch maximum over all, or 0.003 inch in any 6 inches.

**Valve Seat Runout.** Check the valve seat runout with an accurate gauge (Fig. 5). Follow the instructions of the gauge manufacturer. The total runout should not exceed the wear limit.

**Valve Seat Width.** Measure the valve seat width (Fig. 6). It should be within specified limits.

### REAMING VALVE GUIDES

If it becomes necessary to ream a valve guide (Fig. 7) to install a valve with an oversize stem, a reaming kit is available which contains the following reamer and pilot combinations; a 0.003-inch O.S. reamer with a standard diameter pilot, a 0.015-inch O.S. reamer with a 0.003-inch O.S. pilot, and a 0.030-inch reamer with a 0.015-inch O.S. pilot.

When going from a standard size valve to an oversize valve, always use the reamers in sequence. Always reface the valve seat after the valve guide has been reamed.

### REFACING VALVE SEATS

Refacing of the valve seats should be closely coordinated with the refacing of the valve face so the finished seat will match the valve face and be centered. This is important so that the valve and seat will have a good compression and vacuum tight fit. Be sure that the refacer grinding wheels are properly dressed.

100% SATISFACTION GUARANTEED

**BUY IT NOW!**

Click Here To Order

PayPal, American Express, Discover, MasterCard, VISA

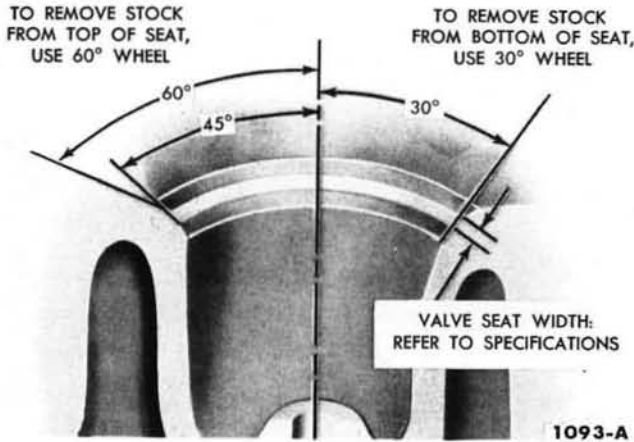


FIG. 8—Valve Seat Refacing—Typical

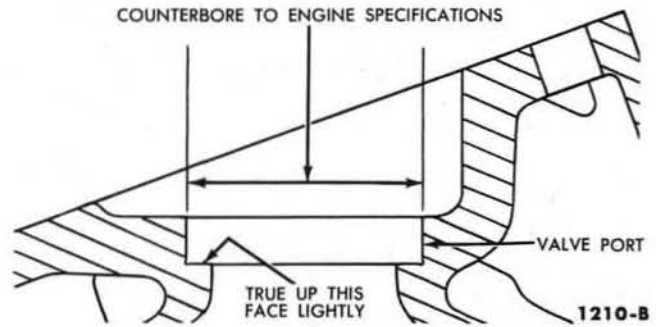


FIG. 9—Counterbore For Oversize Insert—HD and SD V-8 Engines

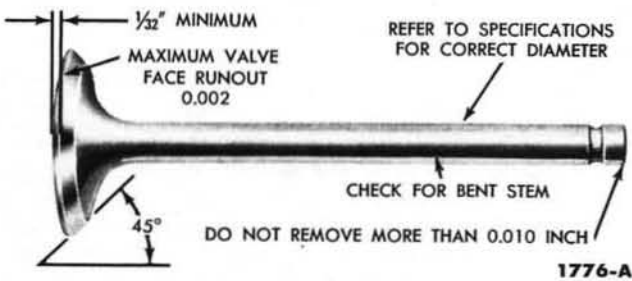


FIG. 10—Critical Valve Tolerances—Typical

Grind the valve seat to a true 45° angle (Fig. 8). Remove only enough stock to clean up pits, grooves, or to correct the valve seat runout. After the seat is ground, measure the seat width (Fig. 6). Narrow the seat, if necessary to bring it within limits.

If the valve seat width exceeds the maximum limit, remove enough stock from the top edge and/or bottom edge of the seat to reduce the width to specifications (Fig. 8). Use a 30° angle grinding wheel to remove stock from the bottom of the seat (raise the seat). Use a 60° angle wheel to remove stock from the top of the seat (lower the seat).

The finished valve seat should contact the approximate center of the valve face. To determine where the valve seat contacts the face, coat the seat with Prussian blue, then set the valve in place. Rotate the valve with pressure. If the blue is trans-

fer to the center of the valve face, valve with a medium grade lapping compound. Remove all the compound from the valve and seat after the lapping operation.

**VALVE SEAT INSERT REPLACEMENT—HD AND SD V-8 ENGINES**

The exhaust valve seats of the 292 HD V-8 are the insert-type and the intake and exhaust valve seats of the 302 and 332 HD V-8 and all SD V-8 engines are the insert type.

To remove the valve seat insert, invert the head and position a drift in the valve port, then drive the insert out.

Counterbore the insert recess to specifications (Fig. 9). Cut slightly below the old counterbore depth to clean up this face (approximately 0.001-0.002 inch). Clean out chips and oil from the recess.

Chill the oversize insert and the stallation tool in dry ice for 1/2

hour. The insert must be installed immediately upon removal from the dry ice. Protect the hands when handling the chilled insert and tool. Position the insert on the tool with the small radius on the outer edge facing outward. Pilot the driving tool in the valve guide, then drive the insert into the counterbore until it is fully seated. Do not peen the area around the insert. Reface the new insert.

**VALVES**

**CLEANING AND INSPECTION**

Remove all carbon and varnish from the valve with a fine wire brush or buffing wheel. The critical inspection points and tolerances of the valve are illustrated in Fig. 10.

Inspect the valve face and the edge of the valve head for pits, grooves, scores, or other defects. Inspect the stem for a bent condition

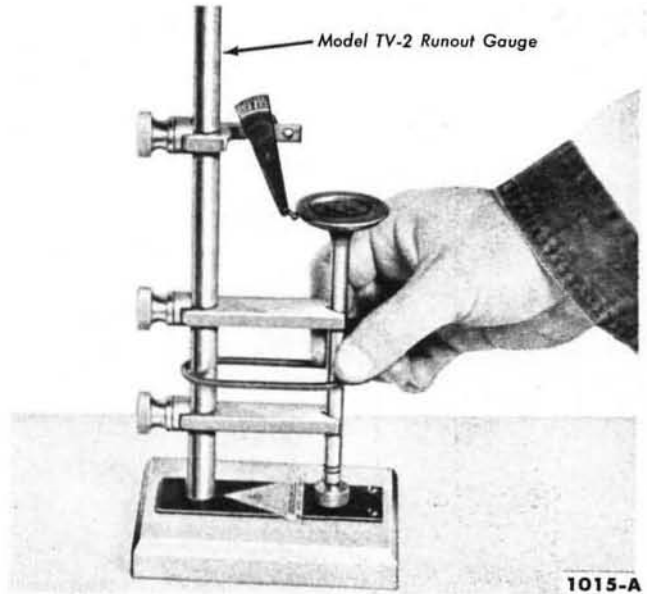


FIG. 11—Valve Face Runout—Typical

**100% SATISFACTION GUARANTEED**

**BUY IT NOW!**

**Click Here To Order**

PayPal, American Express, Discover, MasterCard, VISA

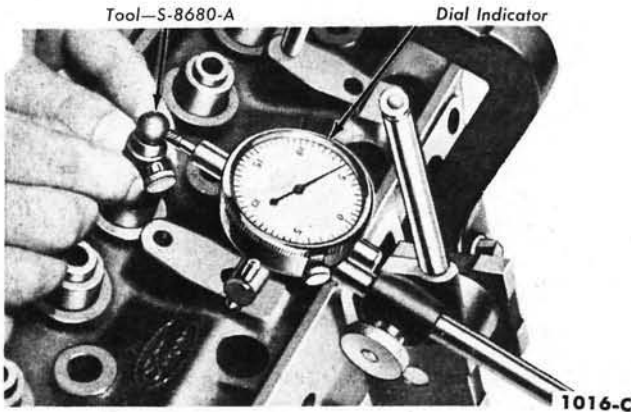


FIG. 12—Valve Stem Clearance—Typical

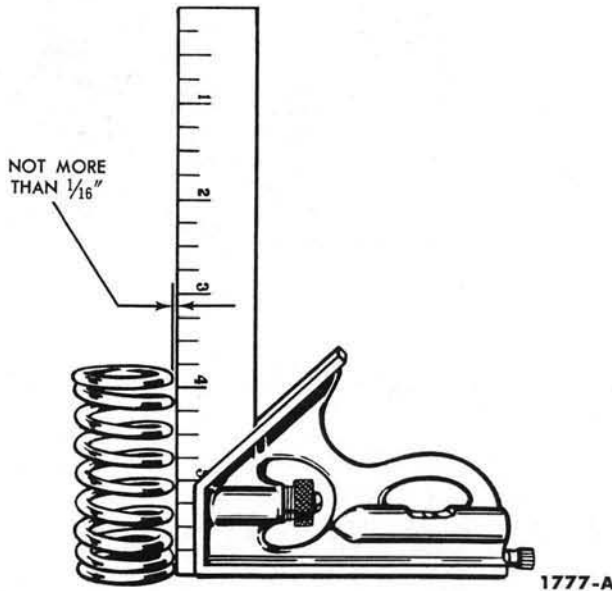


FIG. 14—Valve Spring Squareness

and the end of the stem for grooves or scores. Check the valve head for signs of burning or erosion, warpage, and cracking. Defects, such as minor pits, grooves, etc., may be removed. Discard valves that are severely damaged. **Do not discard sodium cooled valves (exhaust valves of all HD and SD V-8 engines) with other scrap metal in scrap bins. If a sodium cooled valve is accidentally broken sodium exposed, it will react upon contact with water**

jected to dredging.

Inspect the valve springs, valve spring retainers, locks, and sleeves for defects. Discard any defective parts.

**Valve Face Runout.** Check the valve face runout (Fig. 11). It should not exceed the wear limit.

**Valve Stem Clearance.** Check the valve stem to valve guide clearance of each valve in its respective valve guide with the tool shown in Fig. 12 or its equivalent.

Install the tool on the valve stem until fully seated and tighten the set screw, then permit the valve to drop away from its seat until the tool contacts the upper surface of the valve side. Position a dial indicator with its tip against the center portion of

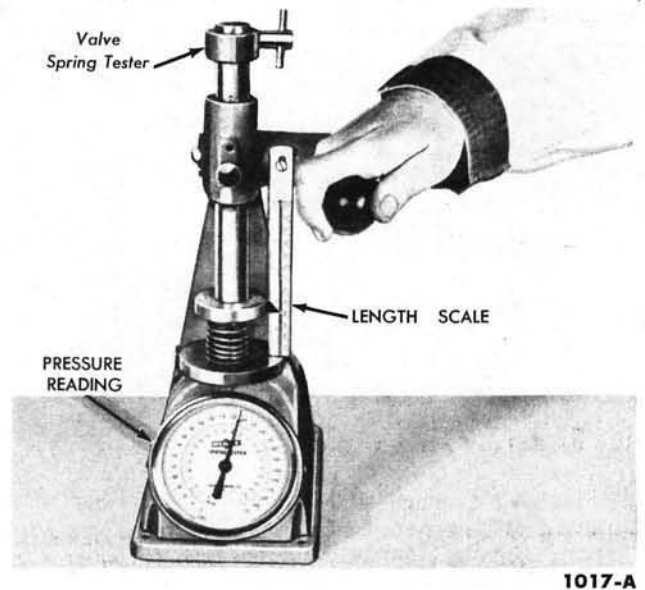


FIG. 13—Valve Spring Pressure

the spherical section of the tool at approximately 90° to the valve stem. Move the tool back and forth on a plane that parallels normal rocker arm action and take the indicator reading without lifting the tool from the valve guide upper surface. Divide the indicator reading by 2 (division factor of the tool) to obtain the actual stem clearance. If the clearance exceeds the wear limit, try a new valve.

**Valve Spring Pressure.** Check the valve spring for proper pressure (Fig. 13). Weak valve springs cause poor performance; therefore, if the pressure of any spring exceeds the wear limit, replace the spring.

**Valve Spring Squareness.** Check each spring for squareness using a steel square and a surface plate (Fig. 14). Stand the spring and square on end on the surface plate. Slide the spring up to the square. Revolve the spring slowly and observe the space between the top coil of the spring and the square. If the spring is out of square more than 1/16 inch, replace it.

#### REFACING VALVES

The valve refacing operation should be closely coordinated with the valve seat refacing operation so that the finished angle of the valve face will match the valve seat. This is important so that the valve and seat will have a good compression tight fit. Be sure that the refacer grinding wheels are properly dressed.

**100% SATISFACTION GUARANTEED**

**BUY IT NOW!**

**Click Here To Order**

PayPal   American Express   Discover   MasterCard   VISA

TABLE 3—Valve Timing Specifications

Engine	Intake Valve				Exhaust Valve			
	Opens		Closes		Opens		Closes	
	Crankshaft Degrees	Camshaft Lobe Lift	Crankshaft Degrees	Camshaft Lobe Lift	Crankshaft Degrees	Camshaft Lobe Lift	Crankshaft Degrees	Camshaft Lobe Lift
223 Six	17° B.T.C.	0.016	53° A.B.C.	0.019	61° B.B.C.	0.016	9° A.T.C.	0.019
292 MD V-8	12° B.T.C.	0.016	54° A.B.C.	0.019	58° B.B.C.	0.015	8° A.T.C.	0.018
292 HD V-8	18° B.T.C.	0.015	58° A.B.C.	0.015	66° B.B.C.	0.013	10° A.T.C.	0.016
302, 332 HD V-8	22° B.T.C.	0.017	62° A.B.C.	0.019	52° B.B.C.	0.017	24° A.T.C.	0.019
SD V-8	18° B.T.C.	0.0175	58° A.B.C.	0.0195	56° B.B.C.	0.0175	20° A.T.C.	0.0195

If the valve face runout is excessive and/or to remove pits and grooves, grind the valve to a true 45° angle. Remove only enough stock to correct the runout or to clean up the pits and grooves. If the edge of the valve head is less than 1/32 inch after refacing, replace the valve as the valve will run too hot in the engine.

Grind off all grooves or score marks from the end of the valve stem, then chamfer as necessary. Do not remove more than 0.010 inch from the stem.

After refacing the valves, it is good practice to lightly lap in the valves with a medium grade lapping compound to match the seats. Be sure to remove all of the compound from the valve and seat after the lapping operation.

#### SELECT FITTING VALVES

If the valve stem to the valve guide clearance exceeds the wear limit, it is recommended that the valve guide be reamed for the next oversized valve stem. Valves with oversized stem diam-

eters of 0.003, 0.015, and 0.030 inch are available for service. **Always reface the valve seat when the valve guide is reamed.**

#### VALVE TIMING

The valve timing should be checked when poor engine performance is noted and all other checks, such as carburetion, ignition timing, etc. fail to locate the cause of the trouble.

Before the valve timing is checked, check for a bent timing pointer. Bring the No. 1 piston to T.D.C. on the compression stroke and see if the timing pointer is aligned with the T.D.C. mark on the damper.

If the valve timing is not within specifications, check the timing chain, camshaft sprocket or gear, crankshaft sprocket or gear, camshaft, and crankshaft in the order of accessibility.

To check the valve timing with the engine installed in the truck, proceed as follows:

Install a quadrant on the crankshaft damper. Back off the No. 1 intake valve adjusting screw, then slide the rocker arm to one side and secure it in this position. Make sure the push rod is in the tappet socket, then install a dial indicator in such a manner as to have the actuating point of the indicator in the push rod socket and in the same plane as the push rod movement (Fig. 18). Turn the crankshaft damper slowly in the direction of rotation until the tappet is on the base circle of the camshaft lobe. At this point the push rod will be in its lowest position. Zero the dial indicator and continue turning the crankshaft slowly in the direction of rotation until the dial indicator registers the specified camshaft lobe lift (Table 3).

Compare the crankshaft degrees indicated on the quadrant with specifications (Table 3). After the valve opening is checked, continue to rotate the engine to check the valve closing.

## 4 TIMING CHAIN, TIMING GEARS, CAMSHAFT, AND BEARINGS

### TIMING CHAIN—223 SIX, 292 MD AND HD V-8

#### CLEANING AND INSPECTION

Clean all parts in solvent and dry them with compressed air. Inspect the chain for broken links and the sprockets for cracks, worn or damaged teeth. It is recommended that all

condition of the gear teeth. If the teeth are scored or the contact pattern on the teeth is uneven, replace the gear(s). It is good practice to replace both gears if either gear needs replacing.

#### BACKLASH

Check the backlash between the camshaft gear and the crankshaft gear with a dial indicator (Fig. 15). Hold the gear firmly against the block while making the check. Refer to the specifications for the backlash limits.

#### RUNOUT

Check the camshaft and crankshaft gear runout with a dial indicator (Fig. 16). If the gear runout is excessive, remove the gear and clean any burrs from the shaft, or replace the gear and/or gears.

### CAMSHAFT AND BEARINGS

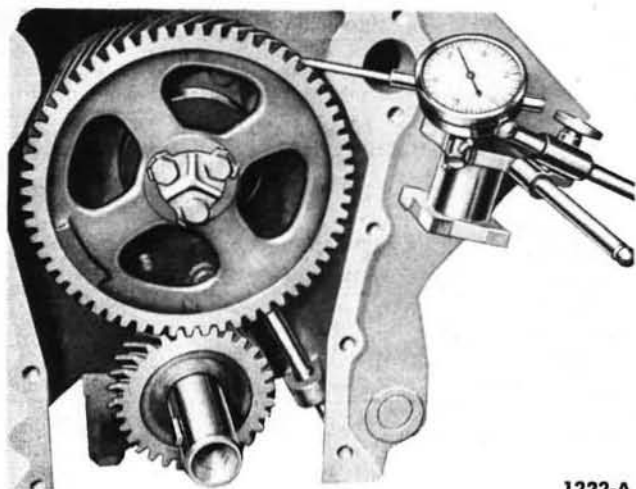
#### CLEANING AND INSPECTION

Clean the camshaft in solvent and wipe dry. Inspect the camshaft lobes for pitting, scoring, and signs of ab-

**100% SATISFACTION GUARANTEED**

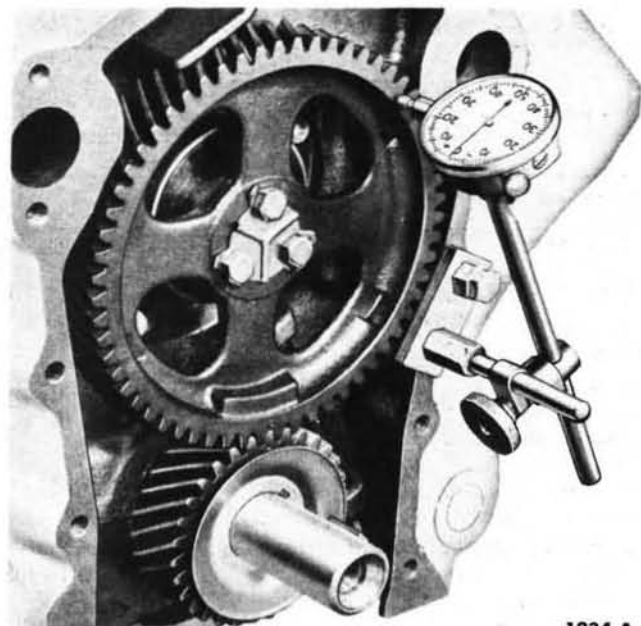
**BUY IT NOW!**

**Click Here To Order**



1222-A

FIG. 15—Camshaft Gear Backlash—Typical



1234-A

FIG. 16—Camshaft Gear Runout—Typical

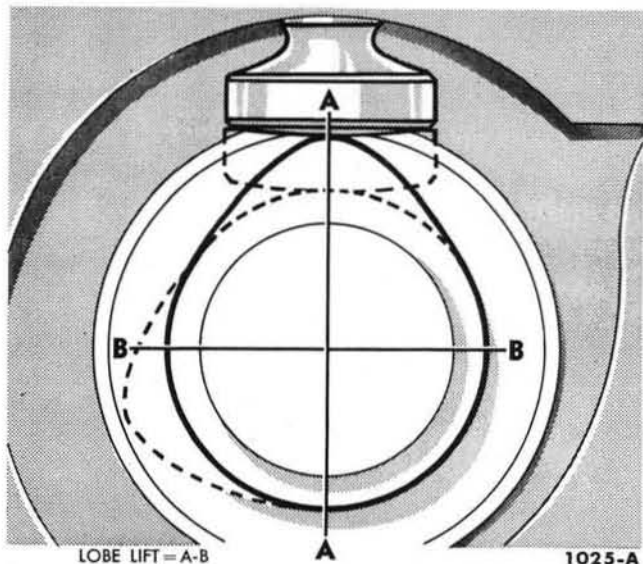


FIG. 17—Camshaft Lobe Lift Measurement

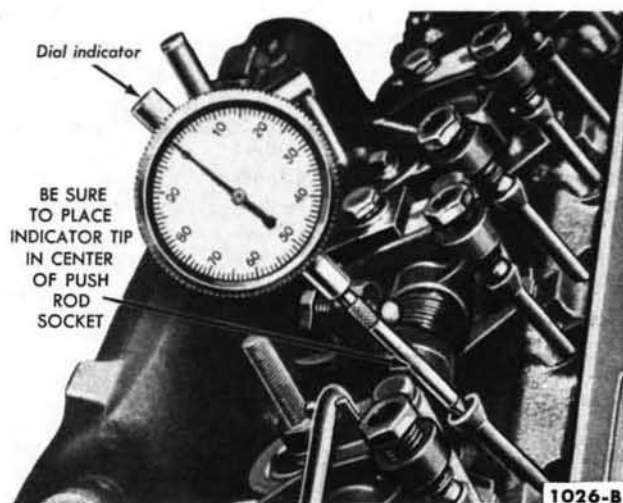


FIG. 18—Camshaft Lobe Lift—Typical

normal wear. Lobe wear characteristics may result in pitting in the general area of the nose portion of the lobe. This pitting is not detrimental to the operation of the camshaft, therefore, the camshaft should not be replaced until the camshaft lobe lift loss has exceeded 0.005 inch. The lift of worn lobes should be measured over the top of

of the bearings. If the clearance exceeds the wear limit, the camshaft journals should be ground for undersize bearings or the camshaft replaced, and/or the bearings should be replaced. Bearings are available pre-finished to size for standard and undersize journal diameters. Check the parts catalog for the undersizes available.

Check the distributor drive gear and governor drive gear on SD V-8 (lines) for broken or chipped teeth. Remove light scuffs, scores, or marks from the camshaft machined surfaces with a smooth oilstone.

#### CAMSHAFT LOBE LIFT (CAMSHAFT INSTALLED)

This procedure is similar to the procedure for checking valve timing. Loosen the valve rocker arm adjusting screw, then slide the rocker arm assembly to one side and secure it in this position. Make sure the push rod is in the tappet socket, then install a dial indicator in such a manner as to have the actuating point of the indicator in the push rod socket and in the same plane as the push rod movement (Fig. 18). Turn the crankshaft damper slowly in the direction of rotation until the tappet is on the



**BUY IT NOW!**

**Click Here To Order**



base circle of the camshaft lobe. At this point, the push rod will be in its lowest position. Set the dial indicator on zero, then continue to rotate the

damper slowly until the push rod is in the fully raised position. Compare the total lift recorded on the indicator with specifications. Continue to ro-

tate the damper until the indicator reads zero. This later step is a check on the accuracy of the original indicator reading.

## 5 FLYWHEEL, CRANKSHAFT, CONNECTING RODS, PISTON ASSEMBLIES, AND BEARINGS

### FLYWHEEL—MANUAL-SHIFT TRANSMISSIONS

#### INSPECTION

Inspect the flywheel for cracks, heat check, or other defects that would make it unfit for further service. Machine the friction surface of the flywheel if it is scored or worn. If it is necessary to remove more than 0.045 inch of stock from the original thickness, replace the flywheel.

Inspect the ring gear for worn, chipped, or cracked teeth. If the teeth are damaged, replace the ring gear.

With the flywheel installed on the crankshaft, check the flywheel face runout.

#### FLYWHEEL FACE RUNOUT

Install a dial indicator so that the tip bears against the flywheel face (Fig. 19). Turn the flywheel, making sure that the crankshaft is full forward or rearward so that crankshaft end play will not be indicated as flywheel runout.

If the runout exceeds the maximum limit, remove the flywheel and check for burrs between the flywheel

and the face of the crankshaft mounting flange. If no burrs exist, check the runout of the crankshaft mounting flange. Replace the flywheel or machine the crankshaft flywheel face if the mounting flange runout is excessive.

### FLYWHEEL—AUTOMATIC TRANSMISSIONS

The procedure for checking the flywheel on trucks with an automatic transmission is covered in Group 4 or 5.

### CRANKSHAFT

Handle the crankshaft with care to avoid possible fractures or damage to the finished surfaces.

#### CLEANING AND INSPECTION

Clean the crankshaft with solvent, then blow out all oil passages with compressed air.

Inspect main and connecting rod journals for cracks, scratches, grooves, or scores. Dress minor imperfections with an oilstone. Reface severely marred journals.

Measure the diameter of each journal in at least four places to determine out-of-round, taper, or under-

size condition (Fig. 20).

If the journals exceed the wear limit, they should be refinished to size for the next undersize bearing.

#### REFINISHING JOURNALS

Refinish the journal to give the proper clearance with the next undersize bearing. If the journal will not "clean up" to give the proper clearance with the maximum undersize bearing available, replace the crankshaft.

Always reproduce the same journal shoulder radius that existed originally. Too small a radius will result in fatigue failure of the crankshaft. Too large a radius will result in bearing failure due to radius ride of the bearing.

After refinishing the journals, chamfer the oil hole, then polish the journal with a No. 320 grit polishing cloth and engine oil. Crocus cloth may also be used as a polishing agent.

### CONNECTING RODS

The connecting rods and related parts should be carefully inspected and checked for conformance to specifications. Various forms of engine wear caused by these parts can be readily identified.

A shiny surface on the pin boss side of the piston usually indicates that a connecting rod is bent or the piston pin hole is not in proper rela-



1049-B

**100% SATISFACTION GUARANTEED**

**BUY IT NOW!**

**Click Here To Order**

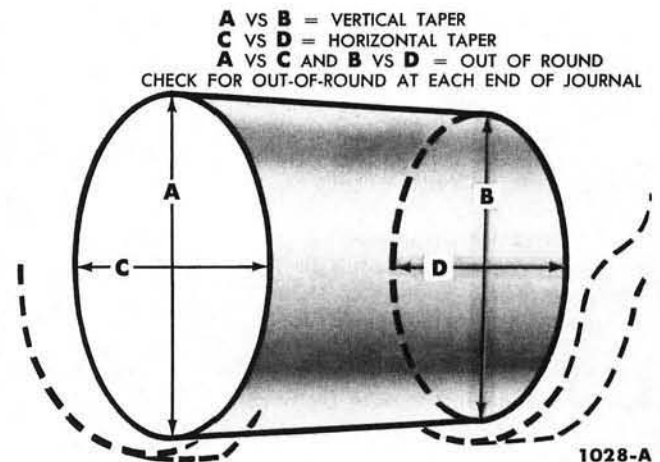



FIG. 20—Crankshaft Journal Measurements

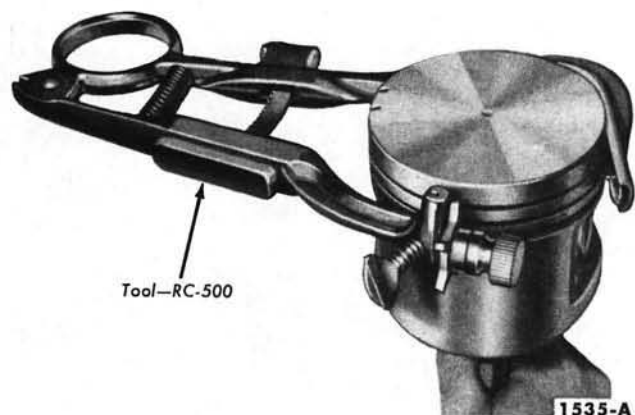


FIG. 21—Cleaning Ring Grooves—Typical

tion to the piston skirt and ring grooves.

Abnormal connecting rod bearing wear can be caused by either a bent connecting rod, an improperly machined journal, or a tapered connecting rod bore.

Twisted connecting rods will not create an easily identifiable wear pattern, but badly twisted rods will disturb the action of the entire piston, rings, and connecting rod assembly and may be the cause of excessive oil consumption.

#### CLEANING AND INSPECTION

Remove the bearings from the rod and cap (identify them if they are to be used again). Clean the connecting rod in solvent, including the rod bore and the back of the inserts. **Do not use a caustic cleaning solution.** Blow out all passages with compressed air.

Inspect the rods for signs of fractures and the bearing bores for out-of-round and taper. If the bore exceeds the maximum limit and/or if the rod is fractured, it should be replaced.

Check the piston pin to connecting rod bushing clearance. Replace the connecting rod if the bushing is so worn that it cannot be reamed or honed for an oversize pin.

Replace defective connecting rod nuts and bolts.

After connecting rods are assembled to the piston, check the rods

### PISTONS, PINS, AND RINGS

#### CLEANING AND INSPECTION

Remove carbon deposits from the piston surfaces and from the underside of the piston head. Clean gum or varnish from the piston skirt, piston pins, and rings with solvent. **Do not use a caustic cleaning solution or a wire brush to clean pistons.** Clean the ring grooves with a ring groove cleaner (Fig. 21). Make sure the oil ring slots (or holes) are clean.

Carefully inspect the pistons for fractures at the ring lands, skirt, and pin bosses, and for scuffed, rough, or scored skirts. If the lower inner portion of the ring grooves have high steps, replace the piston. The step will interfere with ring operation and cause excessive ring side clearance.

Spongy, eroded areas near the edge of the piston top are usually caused by detonation, or pre-ignition. A shiny surface on the thrust surface of the piston, offset from the centerline between the piston pin holes, can be caused by a bent connecting rod. Replace pistons that show signs of excessive wear, wavy ring lands, fractures, and/or damage from detonation or pre-ignition.

Check the piston to cylinder bore clearance with a tension scale and ribbon and the ring side clearance following the recommended procedures.

Replace piston pins showing signs of fracture or etching and/or wear. Check the piston pin fit in the piston rod bushing.

Replace all rings that are scored, pitted, or cracked. Check the end gap and side clearance. It is good

practice to always install new rings when overhauling the engine. **Rings should not be transferred from one piston to another regardless of mileage.**

#### FITTING PISTONS

Pistons are available for service in standard sizes and 0.003, 0.020, 0.030, 0.040, and 0.060-inch oversize. Standard size pistons are divided into two sizes and are identified by a daub of red or blue paint. Refer to the specifications for the available sizes.

The piston and cylinder block should be at room temperature (70°F) when the piston fit is checked. **After any refinishing operation, allow the cylinder bore to cool before the piston fit is checked.**

Calculate the size piston to be used by taking a bore check (Fig. 25), then select the proper size piston to provide the desired clearance.

Make sure the piston and cylinder bore are clean and dry. Attach a tension scale to the end of a feeler gauge ribbon that is free of dents or burrs. The feeler ribbon should be ½-inch wide and of the recommended thickness listed in Table 4.

Position the ribbon in the bore so that it extends the entire length of the piston at 90° from the piston pin location. Invert the piston and install it in the bore so that the end of the piston is about 1½ inches below the top of the cylinder block and the piston pin is parallel to the crankshaft axis.

Hold the piston and slowly pull the scale in a straight line with the ribbon, noting the pull required to remove the feeler ribbon (Fig. 22).

The piston to cylinder bore clearance should be from 0.0008-0.0026 inch (MD and HD V-8 engines) or 0.0011-0.0029 inch (all SD V-8 engines). The wear limit is 0.005 inch.

In Table 4, the diagonal lines represent feeler ribbons of various thicknesses, the horizontal lines represent the pounds pull, and the vertical lines represent clearance. To determine the clearance, locate the line representing the pounds pull required to remove the feeler ribbon from the cylinder bore. Follow the horizontal line to the right until it intersects the diagonal line representing the feeler ribbon. Read down the vertical line for the clearance.

**Example 1.** If a 0.0015-inch feeler ribbon is used and it takes approxi-

connecting rods are assembled to the piston, check the rods

se  
f  
n  
of  
ben  
rod  
plac

**100% SATISFACTION GUARANTEED**

**BUY IT NOW!**

**Click Here To Order**

PayPal American Express Discover NOVUS MasterCard VISA

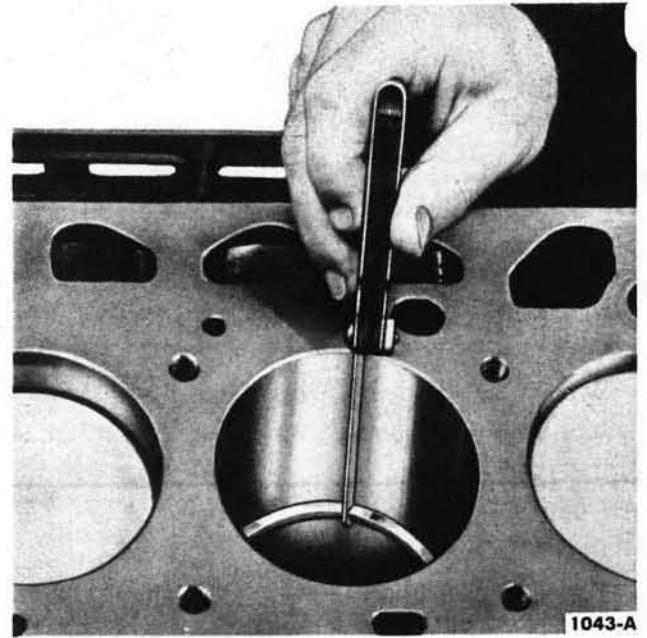
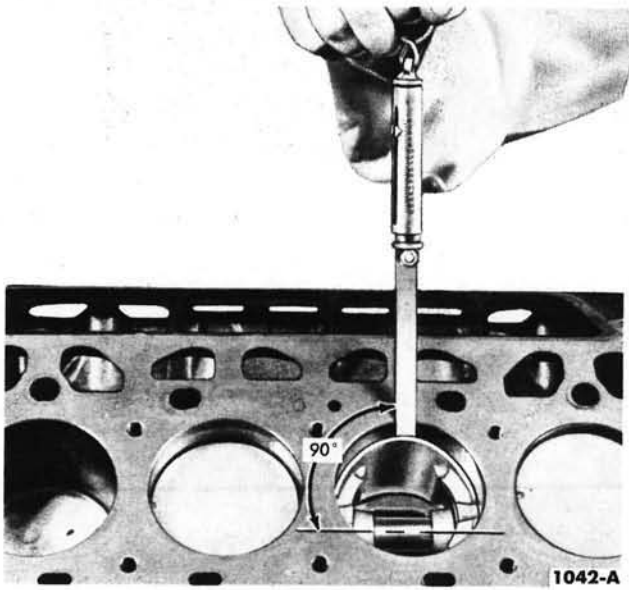
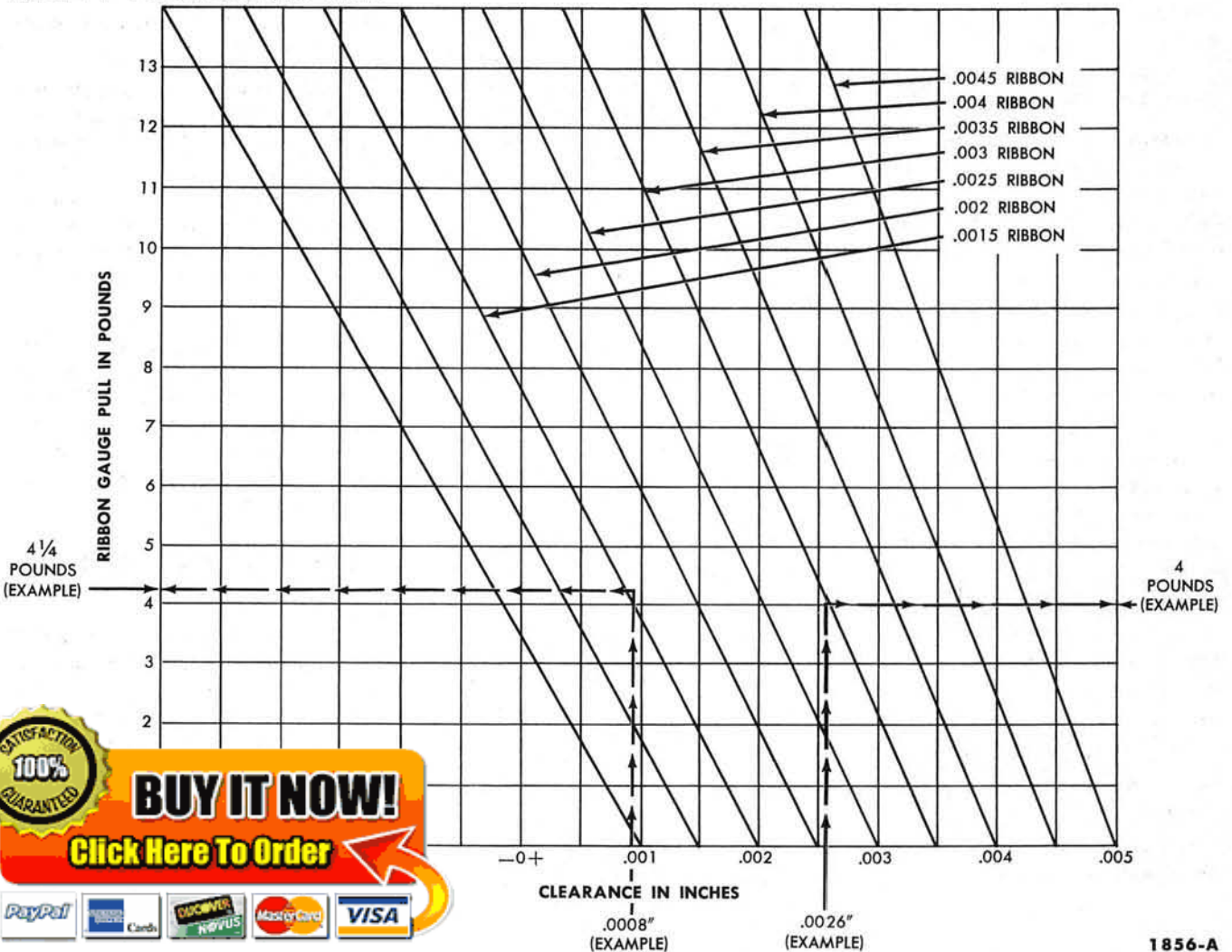


FIG. 22—Checking Piston Fit—Typical

FIG. 23—Piston Ring Gap—Typical

TABLE 4—Piston Clearance Chart



**BUY IT NOW!**

[Click Here To Order](#)



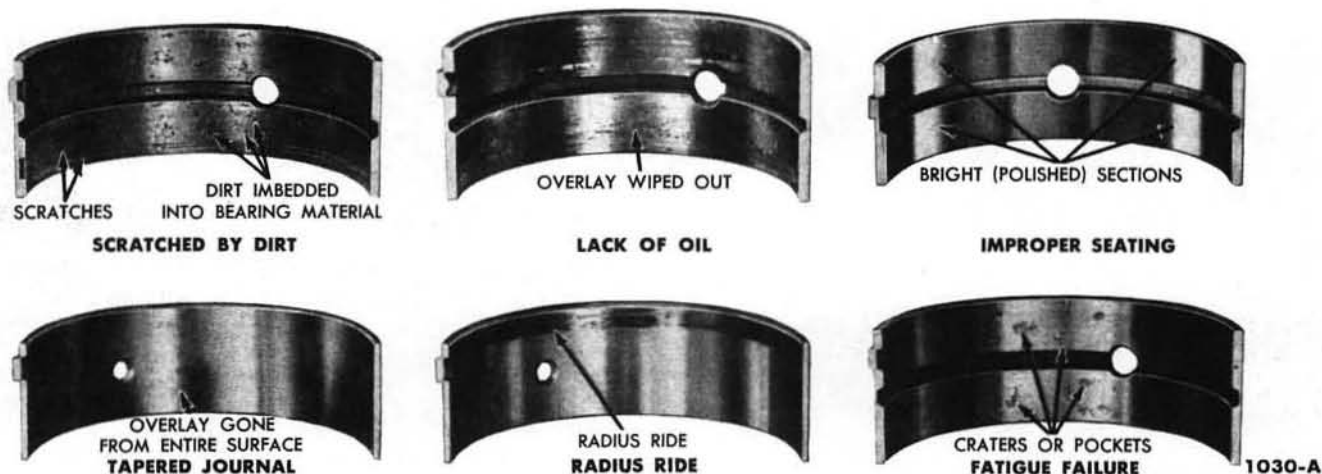


FIG. 24—Bearing Failures—Typical

mately  $4\frac{1}{4}$  pounds pull to remove the feeler ribbon, the clearance is approximately 0.0008 inch. This is determined by locating the pounds pull ( $4\frac{1}{4}$ ) in Table 4 and following the line to the right until it intersects with the diagonal line representing the 0.0015 inch feeler ribbon. Read down the vertical line for the clearance (approximately 0.0008 inch).

**Example 2.** If a 0.003 inch feeler ribbon is used and it takes approximately 9 pounds pull to remove the ribbon, the resultant clearance is approximately 0.0015 inch.

**Example 3.** If a 0.003 inch feeler ribbon is used and it takes approximately 4 pounds pull to remove the feeler ribbon, the resultant clearance is approximately 0.0026 inch.

If the clearance is greater than the maximum limit, recheck calculations to be sure that the proper size piston has been selected, check for a damaged piston, then try a new piston.

If the clearance is less than the minimum limit, recheck calculations before trying another piston. If none can be fitted, refinish the cylinder for the next size piston.

isfactory service provided the piston clearance in the cylinder bore is within limits. If the new rings are to be installed in a used cylinder that has not been refinished, remove the cylinder wall "glaze."

Select the proper ring set for the size piston to be used. The rings must be checked for proper gap in the cylinder bore and for the proper side clearance in the piston grooves. First, check each ring for proper gap as follows:

Position the ring in the cylinder bore in which it is going to be used. Push the ring down into the bore area where normal ring wear is not encountered. Use the head of a piston to position the ring in the bore so the ring is square with the cylinder wall. **Use caution to avoid damage to the ring or cylinder bore.** Measure the gap between the ends of the ring with a feeler gauge (Fig. 23).

If the ring gap is less than the recommended lower limit, try another ring set.

#### FITTING PISTON PINS

The piston pin fit should be a light thumb press fit at normal temperature (70° F). Standard piston pins are color coded green. Pins of 0.001-inch over-size (color coded blue) and 0.002-inch over-size (color coded yellow) are available.

The pin hole in the piston must be reamed, use an expansion-type,

piloted reamer. Place the reamer in a vise and revolve the piston around the reamer. Set the reamer to the size of the pin bore, then expand the reamer slightly and trial ream the pin bore. Take a light cut. Use a pilot sleeve of the nearest size to maintain alignment of the bores.

Check the hole size, using the new piston pin. If the bore is small, expand the reamer slightly and make another cut. Repeat the procedure until the proper fit is obtained. Check the fitted piston pin for fit in the respective rod bushing. If necessary, ream or hone the bushing to fit the pin.

Install the piston pin in the piston and rod. Install a new retainer at each end of the pin to hold it in place. When the retainers are installed, make sure they are properly seated in the grooves provided in the piston pin bore.

#### MAIN AND CONNECTING ROD BEARINGS

Clean the bearing inserts and cap thoroughly. Inspect each bearing carefully. Bearings that have a scored, chipped, or worn surface should be replaced. Typical examples of bearing failures and their causes are shown in Fig. 24. Check the clearance of bearings that appear to be satisfactory with Plastigage. Fit new bearings following the recommended procedure (Part 1-2, 1-3, or 1-4).

...piston has been fitted,

**100% SATISFACTORY GUARANTEED**

**BUY IT NOW!**

**Click Here To Order**

dit... limits... new... will... give... you...

PayPal    American Express    Discover    MasterCard    VISA

## 6 CYLINDER BLOCK

During the disassembly of the cylinder block for engine overhaul, closely inspect the wear pattern on all parts to help diagnose the cause of wear.

### CLEANING AND INSPECTION

Thoroughly clean the block in solvent. Remove old gasket material from all machined surfaces. Remove all pipe plugs which seal oil passages, then clean out all the passages. Blow out all passages, bolt holes, etc. with compressed air. Make sure the threads in the head bolt holes are clean. Dirt in the threads may cause binding and result in a false torque reading. Use a tap to true-up threads and to remove any deposits.

After the block has been thoroughly cleaned, make a check for cracks. Minute cracks not visible to the naked eye may be detected by coating the suspected area with a mixture of 25% kerosene and 75% light motor oil. Wipe the part dry and immediately apply a coating of zinc oxide dissolved in wood alcohol. If cracks are present, the coating will become discolored at the defective area. Replace the block if it is cracked.

Check all machined gasket surfaces for burrs, nicks, scratches, and scores. Remove minor imperfections with an

oil stone. Check the flatness of the cylinder block gasket surface following the procedure and specifications recommended for the cylinder head.

Replace all expansion-type plugs that show evidence of leakage.

Inspect the cylinder walls for scoring, roughness, or other signs of wear. Check the cylinder bore for out-of-round and taper. Measure the bore with an accurate gauge following the instructions of the manufacturer. Measure the diameter of each cylinder bore at the top, middle, and bottom with the gauge placed at right angles and parallel to the centerline of the engine (Fig. 25).

Refinish cylinders that are deeply scored and/or when out-of-round and/or taper exceed the wear limits.

If the cylinder walls have minor surface imperfections, but the out-of-round and taper are within limits, it may be possible to remove the imperfections by honing the cylinder wall and installing new service piston rings providing the piston clearance is within limits. Use the finest grade of honing stone for this operation.

### REFINISHING CYLINDER WALLS

Honing is recommended for refinishing cylinder walls only when the

walls have minor imperfections, such as light scuffs, scratches, etc. The grade of hone to be used is determined by the amount of metal to be removed. Follow the instructions of the hone manufacturer. If coarse stones are used to start the honing operation, leave enough material so that all hone marks can be removed with the finishing hone which is used to obtain the proper piston clearance.

Cylinder walls that are severely marred and/or worn beyond the specified limits should be refinished. Before any cylinder is refinished, all main bearing caps must be in place and tightened to the proper torque so that the crankshaft bearing bores will not become distorted from the boring operation.

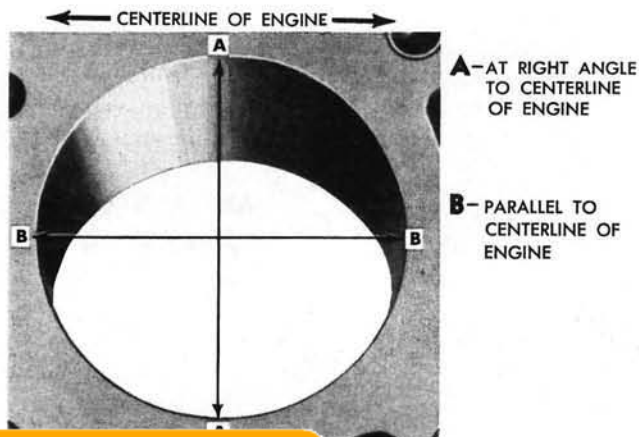
Refinish only the cylinder or cylinders that require it. **All pistons are the same weight, both standard and oversize; therefore, various sized pistons can be intermixed without upsetting engine balance.**

Refinish the cylinder with the most wear first to determine the maximum oversize. If the cylinder will not clean up when bored for the maximum oversize piston recommended, replace the block.

Refinish the cylinder to within approximately 0.0015 inch of the required oversize diameter. This will allow enough stock for the final step of honing so the correct surface finish and pattern are obtained. Use clean sharp hones of No. 220-280 grit for this operation.

For the proper use of the boring equipment, follow the instructions of the manufacturer. Only experienced personnel should be allowed to perform this work.

After the final operation in either of the two preceding refinishing methods and prior to checking the piston fit, thoroughly wash the cylinder walls with a suitable cleaner to remove all abrasive particles, then thoroughly dry. Check the piston fit. Mark the pistons to correspond to the cylinders in which they are to be installed. When the refinishing of all cylinders that require it has been completed and all pistons are fitted, thoroughly clean the entire block to remove a particles from the bearing bores, oil passages, head bolt holes, etc. Coat the cylinder walls with oil.



A—AT RIGHT ANGLE TO CENTERLINE OF ENGINE

B—PARALLEL TO CENTERLINE OF ENGINE

BETWEEN A AND B  
 MEASUREMENT AT TOP OF  
 MEASUREMENT AT BOTTOM  
 1039-A



**BUY IT NOW!**

**Click Here To Order**



Out-Of-Round And Taper—

## 7 OIL PAN, OIL PUMP, AND OIL COOLER

### OIL PAN

Scrape any dirt or metal particles from the inside of the pan. Scrape all old gasket material from the gasket surface. Wash the pan in a solvent and dry it thoroughly. Be sure all foreign matter is removed from below the baffle plate.

Check the pan for cracks, holes, damaged drain plug threads, a loose baffle, and a nicked or warped gasket surface.

Repair any damage, or replace the pan if repairs cannot be made.

### OIL PUMP V-8 ENGINES

Wash all parts in a solvent and dry them thoroughly. Use a brush to clean the inside of the pump housing and the pressure relief valve chamber. Be sure all dirt and chips are removed.

Check the inside of the pump housing and the outer race and rotor for damage or excessive wear.

Check the mating surface of the pump cover for wear. If the cover mating surface is worn, scored, or grooved, replace the cover.

Measure the outer race to housing clearance (Fig. 26).

With the rotor assembly installed in the housing, place a straight edge over the rotor assembly and the housing. Measure the clearance between the straight edge and the rotor and outer race (Fig. 27).

The outer race, shaft and rotor are replaceable only as an assembly.

Check the drive shaft to housing bearing clearance by measuring the O.D. of the shaft and the I.D. of the housing bearing.

Inspect the relief valve spring for a collapsed or worn condition.

Check the relief valve spring tension. If the spring tension is not within specifications and/or the spring is defective, replace the spring.

Check the relief valve piston for scores and free operation in the bore.

### OIL PUMP—223 SIX ENGINE

Wash all parts in a solvent and dry them thoroughly. Use a brush to clean the inside of the pump housing and the pressure relief valve chamber. Be sure all dirt and chips are removed. Remove old gasket material from the pump body and cover.

Inspect the pump body and the gear teeth for damage or wear. Check the gear end clearance with a dial indicator or Plastigage. The Plastigage method is as follows:

Position the gasket on the housing, then place Plastigage on the gears and install the cover. Remove the cover and check the Plastigage reading.

Check the gears for freedom of rotation. Check the compression of the oil pressure relief valve spring and check the clearance of the relief valve in the valve chamber.

### OIL COOLER—SD V-8 ENGINES

Clean the oil cooler as soon as possible after removing it from the engine, or soak it in cleaning solvent until ready to clean. This will prevent hardening and drying of accumulated foreign material.

Immerse the oil cooler in a commercial cleaning solvent and clean the outside of the plates with a stiff bristle brush.

Pressure circulate a standard commercial solvent (at a pressure of approximately 20 psi) through the oil passages of the cooler in the reverse direction of normal flow. Normal flow is from the bottom hole (inlet) to the top hole (outlet). If a circulating pump is not available, soak the cooler in solvent for a few minutes and force the solvent through the oil passages with a plunger or piston-type hand pump. If the oil passages are severely clogged, use an oakite or alkaline solution. After cleaning, pressure flush the cooler with clean hot water.

Thoroughly clean the passages in the cover and clean the relief valve assembly. Remove all old gasket sealer from the cover, oil cooler, and block.

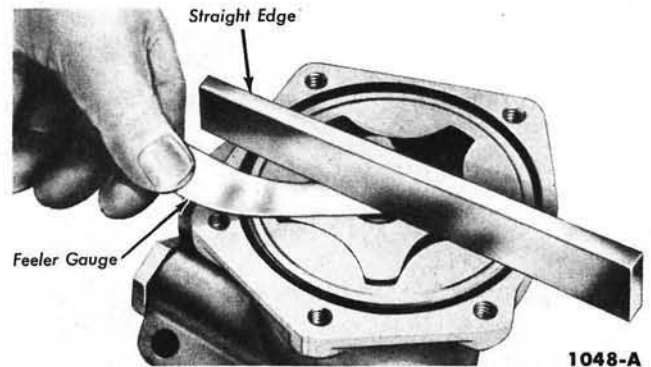
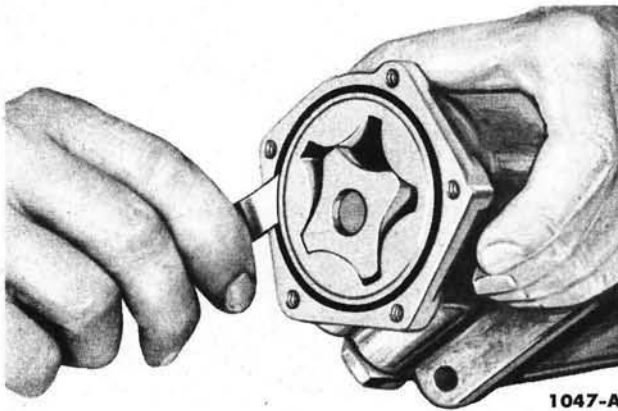


FIG. 27—Rotor End Play—V-8 Engines

100% Satisfaction Guaranteed

BUY IT NOW!

Click Here To Order

PayPal American Express Discover/Novus MasterCard VISA

## PART

## 1-2

## 223 SIX ENGINE

Section	Page
7 Flywheel, Crankshaft, Connecting Rods, and Piston Assemblies .....	1-33
8 Main and Connecting Rod Bearing Replacement .....	1-38
9 Oil Pan, Oil Pump, and Oil Filter .....	1-40
10 Exhaust System .....	1-41

Section	Page
1 Description .....	1-20
2 Engine Removal and Installation .....	1-22
3 Engine Supports .....	1-25
4 Manifolds, Cylinder Head, and Valves .....	1-25

Section	Page
5 Crankshaft Damper, Cylinder Front Cover, and Timing Chain .....	1-30
6 Camshaft, Bearings, and Tappets .....	1-32

The service procedures given are for the engine installed in the chassis unless otherwise noted. Cleaning, inspection, repair, and overhaul procedures are covered in Part I-1.

## 1 DESCRIPTION

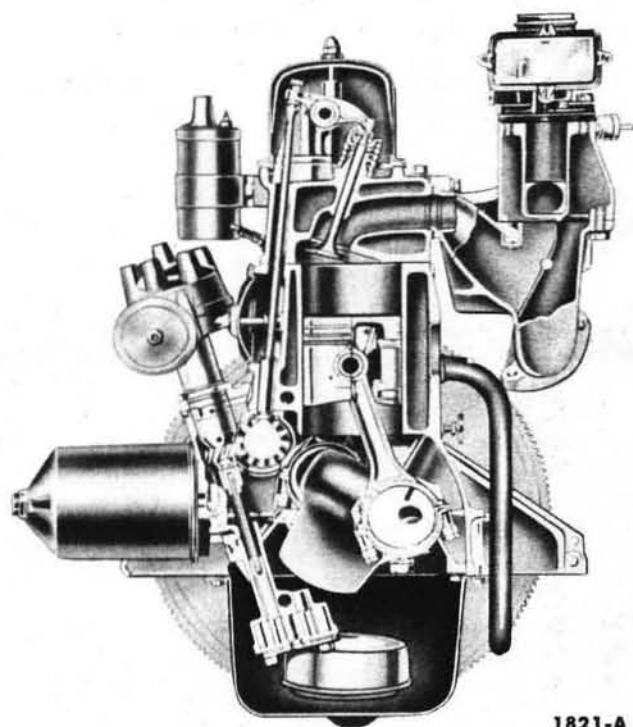
The 223 Six (Figs. 1 and 2) is a 6-cylinder engine with a piston displacement of 223 cubic inches and a compression ratio of 8.1:1. The letter "J" at the beginning of the serial number on the patent plate designates a 223 Six engine.

### MANIFOLDS

A chamber (heat riser) is cast into the intake manifold center section between the carburetor and exhaust manifold. A thermostatically controlled valve, located in the exhaust manifold (Fig. 3), directs exhaust gases into this area to provide the heat necessary to assist in vaporizing the incoming fuel mixture.

### CYLINDER HEAD

The cylinder head carries the valves, valve rocker arm shaft assem-

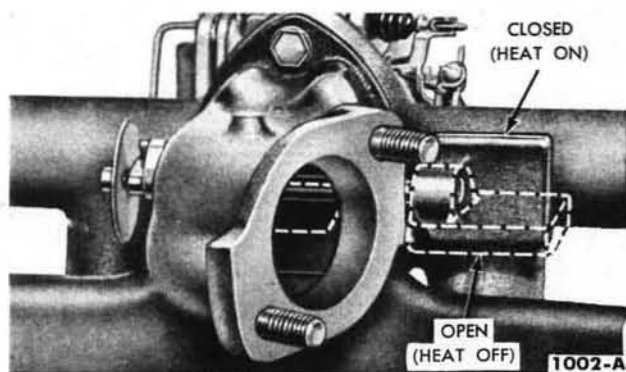


1821-A

FIG. 2—223 Six Engine—Sectional View



1302-B



1002-A

FIG. 3—Exhaust Gas Control Valve



**BUY IT NOW!**

**Click Here To Order**



bly, manifold assembly, ignition coil, the water outlet and thermostat. Valve guides are cast integral in the head. The valves are arranged from front to rear E-I-I-E-I-E-E-I-E-I-E-E.

### CYLINDER BLOCK

The cylinders are numbered from 1-6 starting at the front of the engine. The firing order is 1-5-3-6-2-4.

The oil pump is mounted inside the engine block near the front. The distributor is located on the right side of the engine near the front and drives the oil pump through an intermediate drive shaft.

The crankshaft is supported by four insert-type main bearings. Crankshaft end thrust is controlled by the flanges of the No. 3 main bearing.

The pistons have two compression rings and one oil control ring. The top compression ring is chrome-plated and the lower compression ring is phosphate-coated. The oil control ring assembly consists of a serrated spring and two chrome-plated steel rails.

### VALVE TRAIN

The intake and exhaust valve assemblies are the rotating-type which rotate each time the valve opens and closes.

The push rods are one-piece tubular steel with oil cushioned sockets. The tappets are the solid steel, mushroom-type. Valve lash is maintained by self locking adjusting screws.

The camshaft is supported by four insert-type bearings pressed into the block and is driven by a sprocket and timing chain in mesh with a sprocket on the crankshaft. Camshaft thrust is controlled by a thrust washer located between the camshaft sprocket and the front journal of the camshaft. An eccentric, made integral with the camshaft, operates the fuel pump.

### LUBRICATION SYSTEM

Oil from the oil pan sump is forced through the pressure-type lubrication system (Fig. 4) by a gear-type pump. A spring loaded relief valve in the

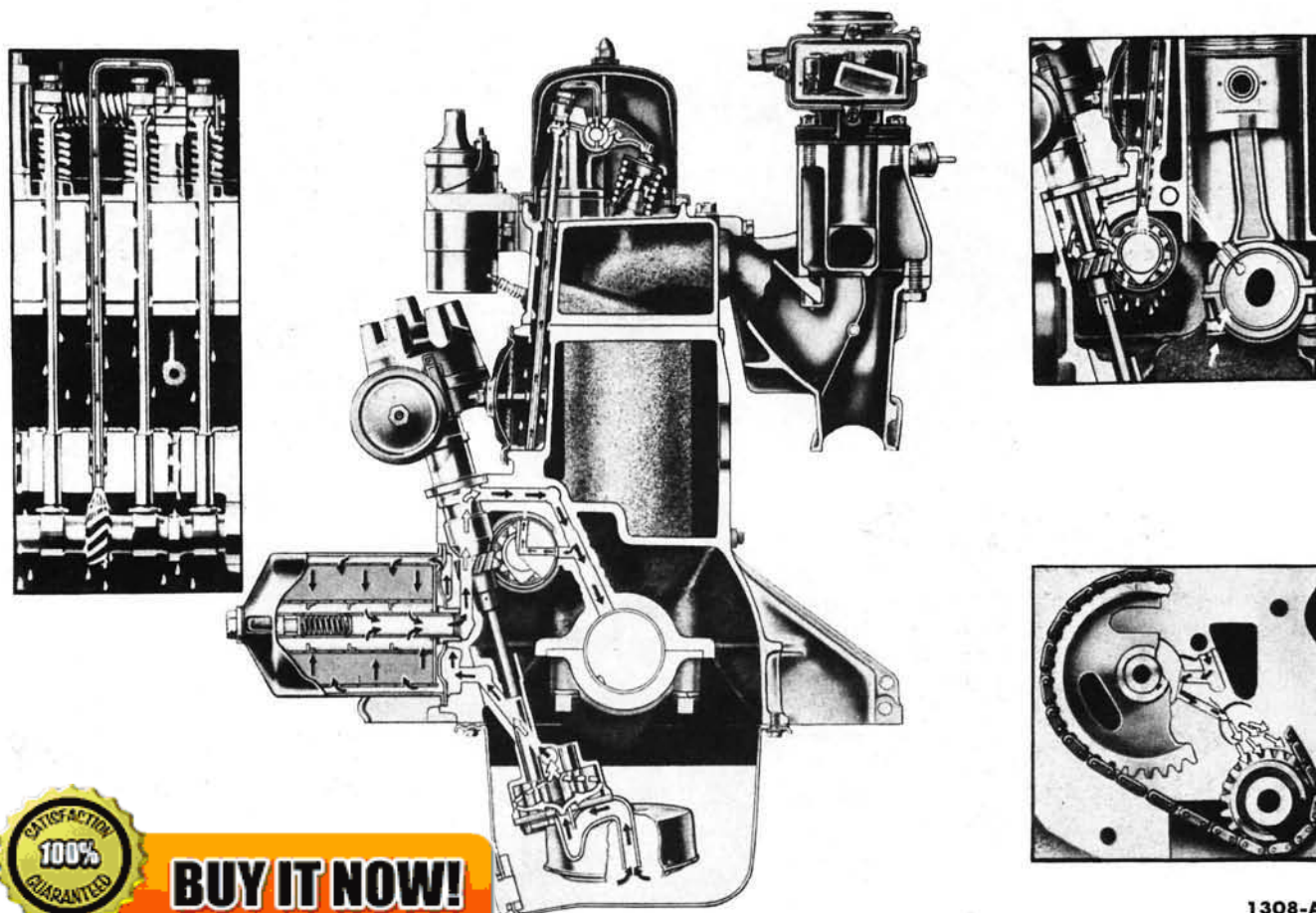
pump limits the maximum pressure of the system. Oil relieved by the valve is directed back to the intake side of the pump.

All the oil discharged by the pump passes through a full flow-type filter before it enters the engine. The filter has an integral relief valve and mounting gasket. The relief valve permits oil to bypass the filter if it becomes clogged, thereby maintaining an emergency supply of oil to the engine at all times. An anti-drain back diaphragm prevents a reverse flow of oil when the engine is stopped.

From the filter, the oil flows into the main oil gallery. The oil gallery supplies oil to all the camshaft and main bearings through a drilled passage in each main bearing web.

The timing chain and sprockets are lubricated through a flat on the No. 1 camshaft bearing.

Oil slingers are provided to prevent leakage by directing oil away from the crankshaft front and rear oil seals.



**100% SATISFACTION GUARANTEED**

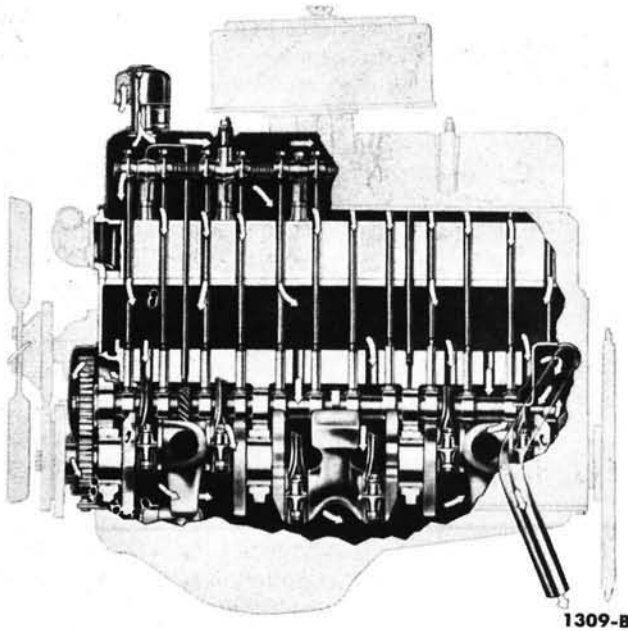
**BUY IT NOW!**

**Click Here To Order**









**FIG. 5—Crankcase Ventilation**

Cylinder walls, pistons, and piston pins are lubricated through a drilled hole in each connecting rod which indexes with a drilled hole in the connecting rod journal of the crankshaft.

Oil under reduced pressure is fed to the valve rocker arm shaft assembly through a drilled passage in the cylinder block at the No. 3 camshaft bearing which indexes with a hole in the cylinder head. An oil inlet tube directs the oil into the hollow rocker shaft through the No. 6 valve rocker arm support. The oil from the shaft flows through drilled holes in each rocker arm to lubricate the shaft bore and the valve and ball end of the rocker arm. The excess oil spirals down the rotating push rod and assists in lubricating the tappet and push rod seat. An oil outlet tube exhausts excess oil from the rocker shaft to lubricate the distributor lower bushing and distributor drive gears. The oil outlet tube is located at the No. 1 rocker arm support. The oil from each rocker arm drains into the push rod

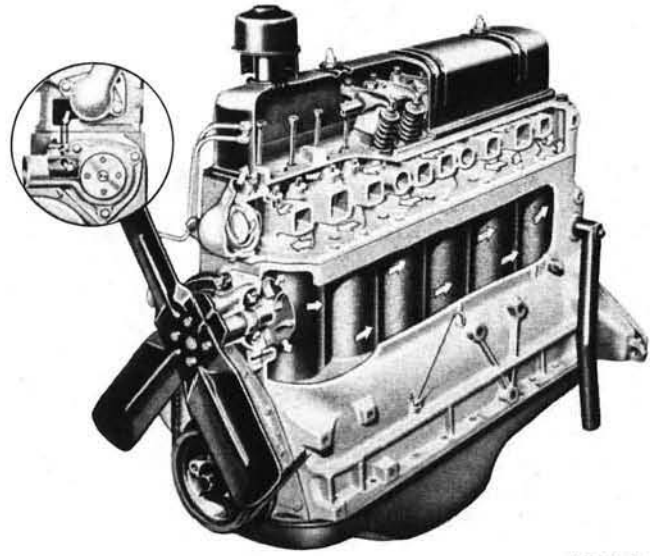
chamber through holes provided in the cylinder head.

The oil in the push rod chamber drains back into the oil pan through an opening at the back of the block.

#### CRANKCASE VENTILATION

Ventilating air (Fig. 5) is provided by the combination oil filler and breather cap located on the front of the valve rocker arm cover. The oil filler cap contains a maze filtering element.

From the filler cap, the filtered air flows into the front section of the valve rocker arm chamber. There are relatively few contaminating vapors at this point and the air has a chance to normalize its temperature before contacting contaminating vapors originating in the crankcase. This warm ventilating air minimizes the formation of crankcase sludge. The ventilating air moves down past the push rods into the crankcase. Air is diverted from the front section of the crankcase through holes in the front of the cylinder block wall to ventilate the



**FIG. 6—Cooling System**

timing chain chamber. The air from the crankcase is then directed into the crankcase ventilation tube by the rotating action of the crankshaft.

#### COOLING SYSTEM

The coolant is drawn from the bottom of the radiator by the water pump which delivers the coolant to the cylinder block (Fig. 6).

As the coolant enters the block, it travels through cored passages to cool the entire length of each cylinder wall. Upon reaching the rear of the cylinder block, the coolant is directed upward into the cylinder head where it cools the combustion chambers, valves, and valve seats on its return to the front of the engine.

At this point, the coolant flows into the water outlet connection, past the water thermostat if it is open, into the top of the radiator. If the thermostat is closed, a small portion of the coolant is returned to the water pump for recirculation. The entire system is pressurized to 7 psi with the use of a pressure-type radiator cap.

## ENGINE REMOVAL AND INSTALLATION

### B- AND F-SERIES REMOVAL

The engine installation for an F-series truck is shown in Fig. 8.

1. Remove the hood. Drain the

cooling system and the crankcase. Remove the radiator.

2. Remove the air cleaner, the tape the carburetor air horn closed. Disconnect the choke control cable at the carburetor, the accelerator shaft

**100% SATISFACTION GUARANTEED**

**BUY IT NOW!**

**Click Here To Order**

PayPal | American Express | Discover | MasterCard | VISA

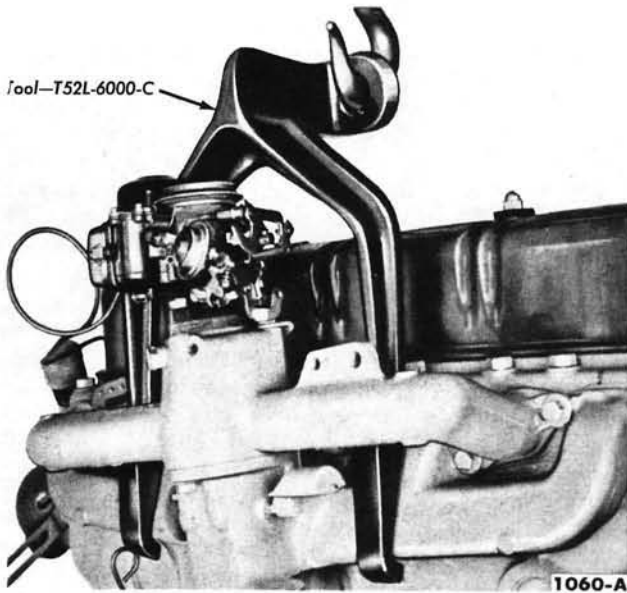


FIG. 7—Engine Lifting Hook

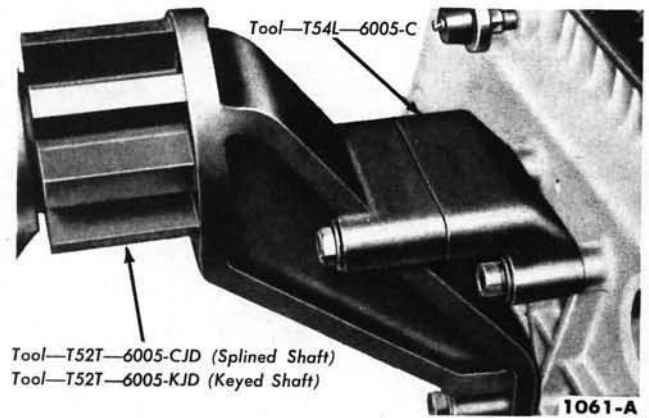
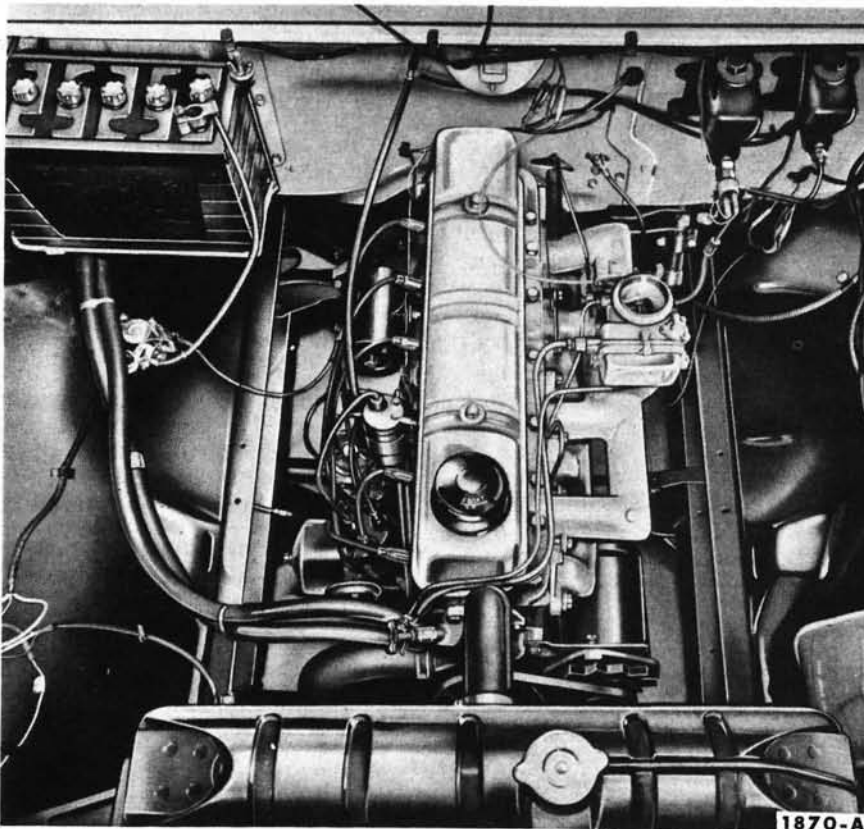


FIG. 9—Engine Mount

FIG. 8—Typical 223 Six Engine Installation  
Series Truck

engine ground strap at the flywheel or converter housing, and remove the flywheel or converter housing to engine block and engine rear plate retaining bolts.

3. Remove the drive belt(s), then remove the fan, spacer, and pulley.

4. Disconnect the heater hoses at the engine. Disconnect the water temperature and oil pressure sending unit wires at the sending units. Disconnect the coil primary wires. Remove the starter.

On a truck with a conventional drive or overdrive transmission, remove the flywheel housing inspection cover and support the transmission with a jack.

On a truck with an automatic transmission, support the transmission with a jack, then remove the converter housing lower access cover and the flywheel to converter bolts. Secure the converter assembly in the housing. Disconnect the transmission oil cooler inlet and outlet lines at the engine.

5. Attach the engine lifting hook (Fig. 7). Remove the engine right and left front support to frame bracket bolts. Lift the engine out of the engine compartment and install it on a work stand (Fig. 9).

#### INSTALLATION

1. Place a new gasket over the exhaust manifold to muffler inlet pipe studs. Lower the engine carefully into the chassis. Make sure the studs on the exhaust manifold are aligned with the holes in the muffler inlet pipe and the dowels in the block engage the holes in the flywheel or converter housing.

On a truck with an automatic transmission, start the converter pilot into

100% GUARANTEED

**BUY IT NOW!**

Click Here To Order

PayPal    American Express    Discover    MasterCard    VISA

inlet pipe and remove the inlet to engine bracket bolt. Disconnect the flexible fuel line at the fuel line, then install a cap on the tank line. Disconnect the generator at the generator. Remove the

the crankshaft. Install the converter housing to engine block and engine rear plate retaining bolts. Remove the support from the transmission. Remove the retainer securing the converter, then install the flywheel to converter bolts. Tighten the bolts to specifications. Install the converter housing inspection cover. Connect the oil cooler inlet and outlet lines.

On a truck with a conventional drive or overdrive transmission, start the transmission main drive gear into the clutch disc. It may be necessary to adjust the position of the transmission in relation to the engine if the input shaft will not enter the clutch disc. **If the engine "hangs up" after the shaft enters, turn the crankshaft slowly (transmission in gear) until the shaft splines mesh with the clutch disc splines.** Install the flywheel housing to engine block and engine rear plate retaining bolts. Remove the support from the transmission. Install the flywheel housing cover.

2. Position the engine ground strap and install the remaining engine rear plate retaining bolts. Install the engine right and left front support bolt and nut, and tighten the nut to 35-45 foot-pounds torque.

3. Install the exhaust manifold to muffler inlet pipe retaining lockwashers and nuts, then tighten the nuts to 23-28 foot-pounds torque. Install the inlet pipe to engine bracket bolt. Connect the generator wires. Remove the cap from the fuel tank line and connect the flexible fuel line. Install the accelerator retracting spring. Connect the transmission throttle control rod at the accelerator bellcrank (automatic transmission). Connect the accelerator shaft to bellcrank rod at the bellcrank and the choke control cable at the carburetor. Remove the tape from the carburetor air horn, then install the air cleaner.

4. Install the pulley, spacer, and fan, then install and adjust the drive belt(s). Install the radiator.

5. Install the starter. Connect the ignition coil primary wires, the oil pressure and water temperature sending unit wires, and the heater hoses.

6. Fill and bleed the cooling system. Fill the crankcase with the grade and quantity of engine

## P-SERIES

### REMOVAL

1. Drain the cooling system and the crankcase. Remove the driver's seat assembly, the master cylinder inspection cover, and the steering column cover plates. Disconnect the accelerator pedal at the accelerator assembly, and the wires from the headlight beam selector switch.

2. Remove the left wheel house panel and the center floor plate. Remove the screws fastening the right side of the engine rear cover panel to the right wheel house panel. Remove the bolts and nuts retaining the rear flange of the engine rear cover to the removable frame cross member and the center floor plate front bracket. Wedge the right and left frame gussets open so the rear flange of the engine rear cover plate will clear the slots. Remove the cover plate. Remove the air cleaner.

3. Remove the accelerator bracket assembly, the accelerator retracting spring, and the carburetor. Disconnect the exhaust manifold at the muffler inlet pipe and remove the inlet pipe to engine bracket bolt. Disconnect the generator wires at the generator. Disconnect the flexible fuel line at the fuel tank line, then install a cap on the fuel tank line.

4. Disconnect the engine temperature and oil pressure sending unit wires at the sending units. Disconnect the coil primary wires. Disconnect the battery ground cable at the battery. Remove the starter.

5. Remove the fan blade and bracket as an assembly, and remove the radiator.

6. Remove the engine right and left front support to frame bracket bolts. Remove the flywheel or converter housing cover. Remove the flywheel housing or converter housing to engine block and engine rear plate retaining bolts. Remove the engine right and left rear support capscrews. Remove the engine crankcase ventilation tube. Support the transmission with a jack.

7. On a truck with an automatic transmission, disconnect the transmission oil cooler inlet and outlet hoses at the engine. Drain the transmission and remove the filler tube. Install the drain plugs in the torque converter.

8. Remove the engine from the truck and install it on a work stand.

### INSTALLATION

1. Place a new gasket over the exhaust manifold to muffler inlet pipe studs. Lower the engine carefully into the chassis. Make sure the studs on the exhaust manifold are aligned with the holes in the muffler inlet pipe and the dowels in the block engage the holes in the converter or flywheel housing.

On a truck with an automatic transmission, start the converter pilot into the crankshaft. Remove the retainer securing the converter, then install the converter to flywheel retaining bolts. Install the converter housing to engine block and engine rear plate retaining bolts. Install the converter housing cover plate. Install the automatic transmission filler tube. Connect the transmission oil cooler hoses. Fill the transmission with the recommended fluid.

On a truck with a conventional drive or overdrive transmission, start the transmission main drive gear into the clutch disc. It may be necessary to adjust the position of the transmission in relation to the engine if the input shaft will not enter the clutch disc. **If the engine "hangs up" after the shaft enters, turn the crankshaft slowly (transmission in gear) until the shaft splines mesh with the clutch disc splines.** Install the flywheel housing to engine block and engine rear plate retaining bolts. Remove the transmission support. Install the flywheel housing cover.

2. Install the engine rear support capscrews, then install safety wire on the capscrews. Install the engine front support to the frame bracket, then tighten the nuts to specifications.

3. Install the fan and bracket and adjust the tension of the drive belts. Install the radiator.

4. Remove the cap from the fuel tank line and connect the flexible fuel line. Install the exhaust manifold to muffler inlet pipe retaining lockwashers and nuts, then tighten the nuts to 23-28 foot-pounds torque. Connect the inlet pipe to engine bracket. Install the carburetor, the accelerator bracket assembly, and the accelerator retracting spring. Connect all the carburetor linkage and lines.

5. Install the starter, connect the coil primary wires, the engine temperature and oil pressure sending unit wires, the generator wires, and the battery cable. Install the crankcase ventilation tube.



**BUY IT NOW!**

**Click Here To Order**



6. Install the frame cross member. Position the engine cover assembly and the engine rear panel assembly and install the flange of the engine cover rear panel between the frame gussets and the cross member. Remove the wedges.

7. Install the right side of the engine rear cover panel to the right wheel house panels. Install the bolts

and nuts retaining the rear flange of the engine rear cover to the frame cross member and the center floor plate front bracket.

8. Connect the headlight beam selector switch wires and the accelerator pedal.

9. Install the engine left cover to wheel house panel, the steering col-

umn cover plates, and the master cylinder inspection cover. Install the driver's seat assembly.

10. Fill and bleed the cooling system. Fill the crankcase with the proper grade and quantity of engine oil. Operate the engine at fast idle and check for coolant and oil leaks.

On a truck with an automatic transmission, adjust the throttle linkage.

### 3 ENGINE SUPPORTS

The engine is supported on each side at the front (Fig. 10) and rear (Fig. 11) of the crankcase.

#### ENGINE FRONT SUPPORT REPLACEMENT—ENGINE IN CHASSIS

1. Remove the nut, washer, bolt, and lower insulator from each front support. Raise the front of the engine and remove the upper insulators.

2. Place the upper insulator in position on each frame bracket, then lower the engine.

3. Install the lower insulator, bolt, washer, and nut on each side of the engine. Tighten the bolts to specifications.

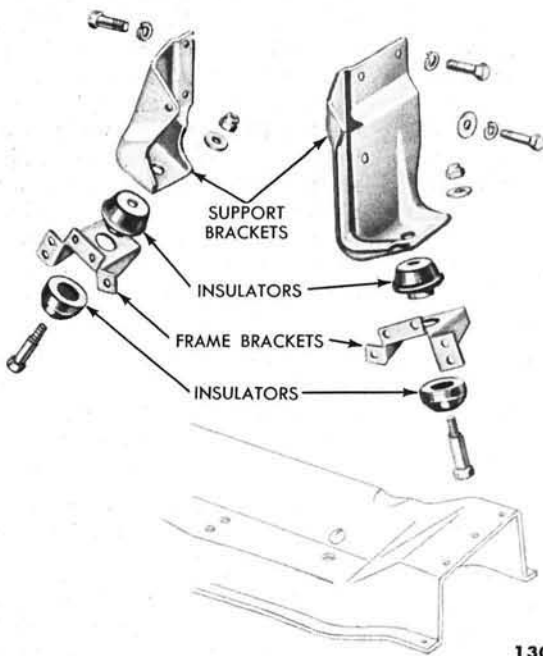
#### ENGINE REAR SUPPORT REPLACEMENT

1. Remove the nut, bolt, lower in-

ulator, and spacer from each rear support. Raise the rear of the engine, then remove the insulators.

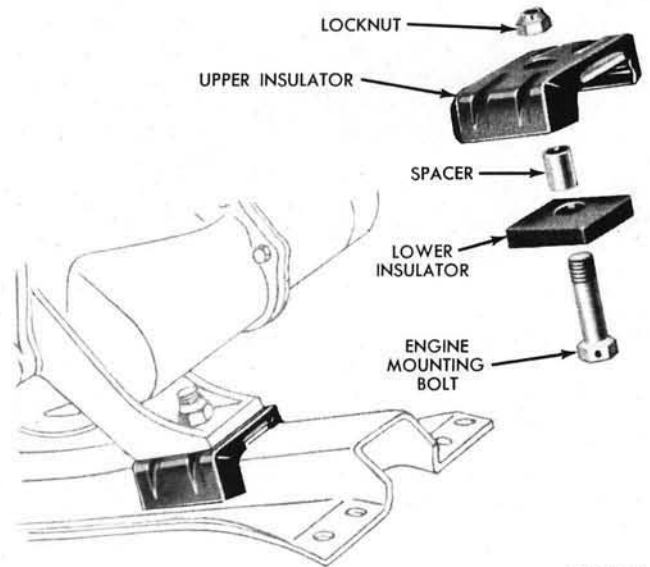
2. Place a new upper insulator in position on each side of the engine, then lower the engine.

3. Install the spacer, the lower insulator, bolt, and nut on each side of the engine. Tighten the bolts to specifications.



1305-A

FIG. 10—Engine Front Support



1304-A

FIG. 11—Engine Rear Support

### 4 MANIFOLDS, CYLINDER HEAD, AND VALVES

**100% SATISFACTION GUARANTEED**

**BUY IT NOW!**

**Click Here To Order**

1. the accelerator air hose closed

PayPal American Express Discover Novus MasterCard VISA

On a truck with an automatic transmission, disconnect the throttle control rod and the accelerator assembly connecting link at the accelerator pedal. Disconnect the accelerator re-tracting spring at the block mount-

ed bracket, then remove the bracket.

On a truck with a conventional drive or overdrive transmission, disconnect the accelerator retracting spring and the accelerator rod assembly at the bellcrank.

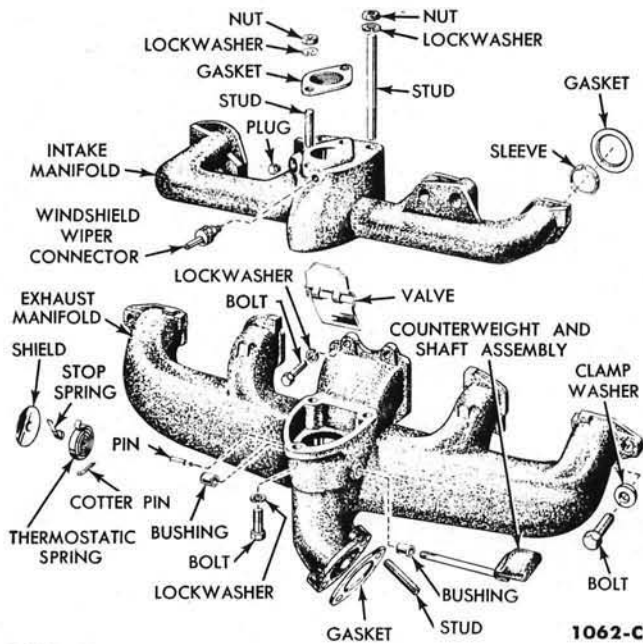


FIG. 12—Manifold Assembly

2. Disconnect the vacuum line at the intake manifold. Disconnect the choke control cable, the fuel inlet line, and the distributor vacuum line at the carburetor, then remove the carburetor and gasket.

3. Disconnect the muffler inlet pipe from the exhaust manifold. Remove the bolts fastening the manifold to the head, and lift the manifold assembly from the head. Remove the gaskets and sleeves.

4. Remove the nuts and bolt joining the intake and exhaust manifolds, then separate the manifolds.

**INSTALLATION**

1. Place the intake manifold over the studs on the exhaust manifold.

Install the lockwashers, nuts and bolt, then tighten them finger tight.

2. Install new intake manifold gaskets using new sleeves, if necessary, in the cylinder head ports. Place a new exhaust manifold to muffler inlet pipe gasket over the studs on the exhaust manifold. Coat the mating surfaces lightly with graphite grease, then place the manifold assembly in position against the head. **Make sure the port openings in the manifold assembly are aligned with the port openings in the cylinder head and that none of the steel gaskets have become dislodged.**

3. Install the attaching washers and bolts, then tighten the bolts to 23-28 foot-pounds torque, tightening from

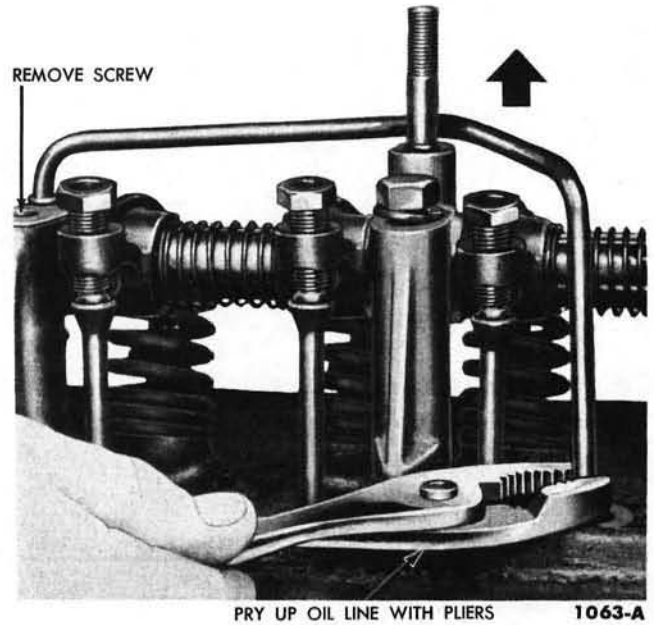


FIG. 13—Oil Line Removal

the center to the ends. Tighten the bolt and nuts joining the intake and exhaust manifolds to 23-28 foot-pounds torque. Install the exhaust manifold to muffler inlet pipe lockwashers and nuts, then tighten the nuts to 23-28 foot-pounds torque.

4. Position the carburetor gasket on the intake manifold, then install the carburetor. Tighten the carburetor retaining nuts to 12-15 foot-pounds torque. Connect the vacuum line to the intake manifold. Connect the choke control cable, the fuel inlet line, and the distributor vacuum line to the carburetor.

On a truck with an automatic transmission, install the accelerator retracting spring bracket, then connect the spring. Connect the accelerator assembly connecting link and the throttle control rod.

On a truck with a conventional drive or overdrive transmission, connect the accelerator retracting spring and the accelerator rod assembly.

5. Remove the tape from the carburetor air horn, then install the air cleaner.

**EXHAUST GAS CONTROL VALVE REPLACEMENT**

The exhaust gas control valve is located in the outlet of the exhaust manifold. Normally, it does not require replacement unless it becomes inoperative due to excessive corrosion or damage.

1. Remove the manifold assembly



**BUY IT NOW!**

**Click Here To Order**



1064-A

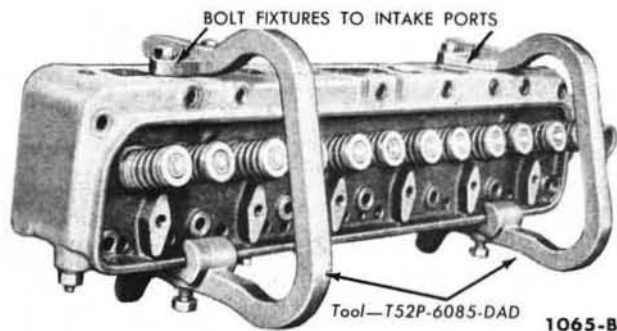


FIG. 15—Cylinder Head Holding Fixture

and separate the intake and exhaust manifolds. Before removing the control valve assembly, note the position of the counterweight in relation to the valve plate. Remove the cotter pin, shield, stop spring and thermostatic spring from the front end of the shaft.

2. Using an acetylene torch in the inside of the manifold, cut the shaft on both sides of the valve plate. Use caution to avoid damage to the shaft bearing bores. Remove the valve and shaft pieces.

3. Clean the bushings of corrosion and repair any damage that may have occurred. Replace the bushings if necessary. When new bushings are installed, there should be a distance of  $2\frac{3}{8}$  inches from the inside edge of one bushing to the inside edge of the other bushing. The bushing should be equally spaced within the counterbores. After installation, ream the bushings with a  $\frac{1}{16}$ -inch reamer. Lubricate the new shaft and bushings with a penetrating oil and graphite mixture.

4. Insert the shaft through the bushings and valve plate. Rotate the shaft in the valve plate until the counterweight is in the normal "up" (heat on) position (Fig. 3).

5. Tack weld the valve to the shaft, then move the assembly back and forth to check for a binding condition. If there is no binding, weld the valve to the shaft in the original manner. The shaft and valve are stainless steel to minimize corrosion and/or damage by excessive heat.

6. Install the thermostatic spring in the shaft slot. Wind the spring  $\frac{3}{4}$  turn the open end of the spring on the pin. The thermostatic

and cotter pin. Lubricate the shaft bushings while operating the valve manually to replace the original lubricant lost by the welding operation. Install the manifold assembly.

### CYLINDER HEAD REMOVAL

1. Drain the cooling system. Remove the air cleaner, then tape the carburetor air horn closed. Disconnect the radiator upper hose at the radiator, the heater hose at the water outlet housing, the oil pressure and water temperature sending unit wires at the sending units, and the battery ground cable at the cylinder head. Disconnect the carburetor fuel inlet line and the vacuum line at the fuel pump, and the distributor vacuum line at the distributor. Disconnect the high tension lead at the coil, then remove the coil from the head and move it to one side. Remove the distributor cap. Disconnect the spark plug wires, then remove the spark plugs.

On a truck with an automatic transmission, disconnect the throttle control rod and the accelerator assembly connecting link at the accelerator bracket. Disconnect the accelerator retracting spring at the block mounted bracket, then remove the bracket.

On a truck with a conventional drive or overdrive transmission, disconnect the accelerator retracting spring and the accelerator rod assembly at the bellcrank.

2. Disconnect the fuel inlet line and the distributor vacuum line at the carburetor, and the vacuum line at the intake manifold, then remove the three lines as an assembly. Disconnect the choke control cable at the carburetor.

3. Remove the valve rocker arm cover. Remove the cap screw and bracket from the No. 6 valve rocker arm support. Pull the oil inlet line of the support, then pull it out of

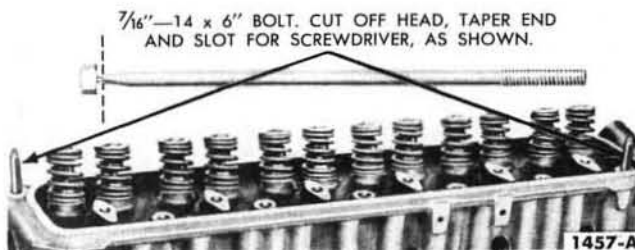


FIG. 16—Cylinder Head Guide Studs

the block with pliers (Fig. 13). Be careful not to damage the line. Remove the cap screws from the No. 1 valve rocker arm support, then remove the oil outlet line and bracket. Loosen all rocker arm adjusting screws to remove the valve spring load from the rocker arms, then remove the valve rocker arm shaft assembly. Remove the valve push rods in sequence and identify them so they can be installed in their original positions (Fig. 14).

4. Remove the manifold to cylinder head bolts, and pull the manifold assembly away from the cylinder head. Brace the assembly so the inlet pipe will not be damaged. Install the cylinder head holding fixtures for convenience in lifting the head and to protect the gasket surfaces (Fig. 15). Remove all cylinder head bolts. Install the cylinder head guide studs (Fig. 16). Lift the cylinder head assembly off the engine. Do not pry between the head and block as the gasket surfaces may become damaged.

### VALVE ROCKER ARM SHAFT DISASSEMBLY

1. Remove the cotter pins from each end of the rocker arm shaft, and remove the flat washers and spring washers. Slide the rocker arms, springs, and supports off the shaft. Be sure to identify the parts.

2. If it is necessary to remove the plugs from each end of the shaft, drill or pierce the plug on one end, then use a steel rod to knock out the plug on the opposite end. Working from the open end, knock out the remaining plug.

### VALVE ROCKER ARM SHAFT ASSEMBLY

1. Oil all moving parts with engine oil.

2. If the plugs were removed from the end of the shaft, use a blunt tool

**100% SATISFACTION GUARANTEED**

**BUY IT NOW!**

**Click Here To Order**

PayPal    American Express    Discover    MasterCard    VISA

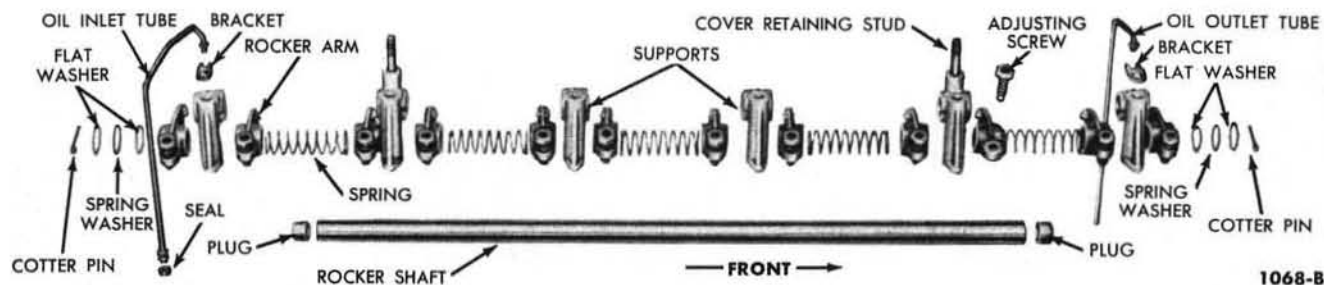


FIG. 17—Valve Rocker Arm Shaft Assembly

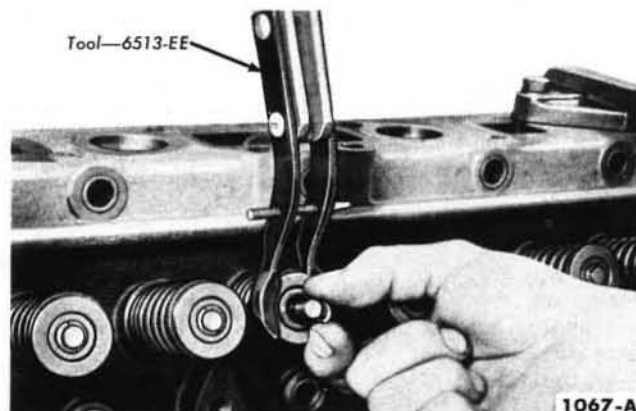


FIG. 18—Valve Stem Lock Removal or Installation

or large diameter pin punch and install a plug, cup side out, in each end of the rocker arm shaft.

3. Install a flat washer, spring washer, another flat washer, and a cotter pin on one end of the shaft.

4. Install the rocker arms, supports, and springs (Fig. 17). Install the remaining flat washers with the spring washer between them, and install the cotter pin.

## CYLINDER HEAD DISASSEMBLY

1. Remove deposits from the combustion chambers and valve heads with a scraper and a wire brush before removing the valves. **Be careful not to scratch the cylinder head gasket surface.**

2. Compress the valve spring (Fig. 18), then remove the valve retainer locks and release the spring. Remove the valve, spring retainer, spring, and valve. Discard all valve

which it was fitted. Install a new stem seal on the valve.

2. Install the valve spring, then install the valve spring retainer, and sleeve. Compress the spring, and install the retainer locks (Fig. 18).

3. Measure the assembled height of the valve springs from the surface of the cylinder head spring pad to the underside of the spring retainer with dividers (Fig. 19). Check the dividers against a scale. If the assembled height is greater than  $1\frac{13}{16}$  inches, install the necessary 0.030-inch thick spacer(s) between the cylinder head spring pad and the valve spring to bring the assembled height to the recommended dimension of  $1\frac{29}{32}$ – $1\frac{13}{16}$  inches. **Do not install spacers unless necessary. Use of spacers in excess of recommendations will result in overstressing the valve springs which will lead to excessive load loss and spring breakage.**

## CYLINDER HEAD INSTALLATION

1. Clean deposits from the head and block gasket surfaces. Inspect the head for any damage and repair as necessary. Position the gasket over

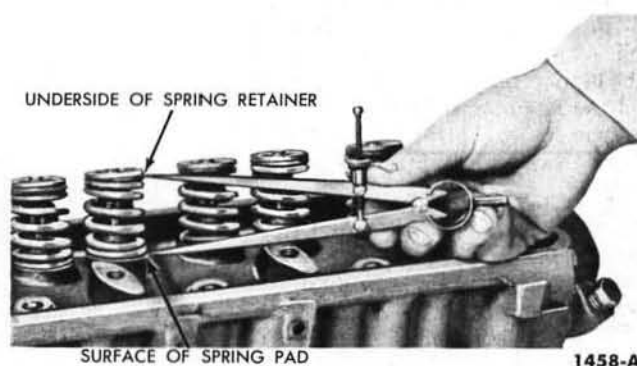


FIG. 19—Valve Spring Assembled Height

the guide studs on the cylinder block. Do not apply sealer to the gasket or gasket surface of the head or block.

2. Lift the cylinder head over the guides and slide the head down carefully. Before installing the cylinder head bolts, coat the threads of each bolt with a small amount of water resistant sealer. Install, but do not tighten, two bolts at opposite ends of the head to hold the head and gasket in position. Remove the guides, then install the remaining bolts. Remove the cylinder head holding fixtures.

3. The cylinder head bolt tightening procedure is performed in three progressive steps. Tighten the bolts to 55 foot-pounds torque in the proper sequence (Fig. 20), then tighten them to 65 foot-pounds torque in the same sequence. Finally, tighten the bolts to 75 foot-pounds torque in the same sequence. **After the cylinder head bolts have been tightened to specifications, the bolts should not be disturbed.**

4. Install the push rods in their proper sequence, positioning the lower end of the rods in the tappet sockets. Position the valve rocker arm shaft assembly on the head, then install the oil outlet line, bracket, and retaining screw on the No. 1 support. Make sure the oil line enters the shaft

**100% SATISFACTORY GUARANTEED**

**BUY IT NOW!**

**Click Here To Order**

FROM WHICH IT WAS REMOVED, OR TO

PayPal    American Express    Discover    MasterCard    VISA

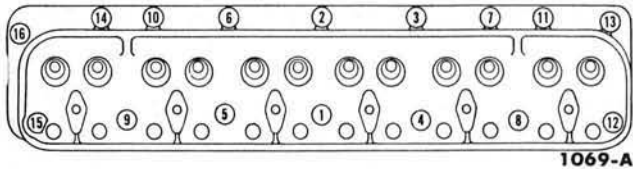


FIG. 20—Cylinder Head Bolt Tightening Sequence

locating hole. Install a new "O" ring seal on the lower end of the oil inlet line, then position the line in the No. 6 support. Make sure the lower end of the oil line "O" ring seal is in the oil supply counterbore, then install the bracket and support bolt. Tighten all the retaining bolts to 45-55 foot-pounds torque. Perform a preliminary (cold) valve lash adjustment.

5. Install the manifold to cylinder head bolts and tighten them to 23-28 foot-pounds torque. Position the two vacuum lines and the carburetor fuel inlet line on the engine. Connect the distributor vacuum line and the carburetor fuel inlet line at the carburetor, and the manifold vacuum line at the manifold. Connect the choke control cable. Remove the tape from the carburetor air horn.

On a truck with an automatic transmission, install the accelerator retracting spring bracket on the block, then connect the spring. Connect the throttle control rod and the accelerator assembly connecting link.

On a truck with a conventional drive or overdrive transmission, connect the accelerator rod assembly and the accelerator retracting spring.

6. Install the ignition coil, spark plugs, and the distributor cap. Connect the spark plug wires and the coil high tension lead. Connect the carburetor fuel inlet line and the vacuum line at the fuel pump, and the distributor vacuum line at the distributor. Connect the battery ground cable, the oil pressure and water temperature sending unit wires, the heater hose, and the radiator upper hose. Fill and bleed the cooling system.

7. Start the engine and operate it for a minimum of 30 minutes at approximately 1200 rpm to stabilize engine temperatures. Check the valve lash with the engine idling and adjust

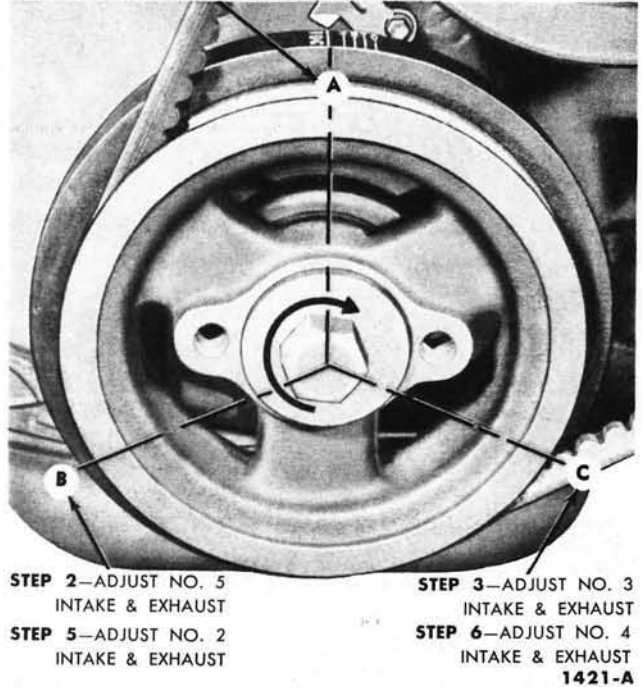
that the gasket seats evenly all around the head. Install the rubber seals on the studs making sure they are centered in the cover openings. Tighten the nuts to 2.0-2.5 foot-pounds torque. Install the air cleaner.

### VALVE LASH ADJUSTMENT

It is very important that the valve lash be held as close as possible to the correct specifications. If the lash is set too close, the valve will open too early and close too late, resulting in rough engine idle. Burning and warping of the valves will occur also because the valves cannot make firm contact with the seats long enough to cool properly. If the lash is excessive, it will cause the valves to open too late and close too early causing valve bounce. In addition, damage to the camshaft lobe is likely because the tappet foot will not follow the pattern of the camshaft lobe, causing a shock contact between these two parts.

If the cylinder head or the valve cover assembly has been removed and installed, it will be necessary to make a preliminary (cold) valve lash adjustment before starting the engine. If the adjustment is necessary for an engine tune-up, follow the preliminary adjustment procedure.

STEP 1—SET NO. 1 PISTON ON T.D.C. AT END OF COMPRESSION STROKE. ADJUST NO.1 INTAKE AND EXHAUST.  
STEP 4—ADJUST NO. 6 INTAKE AND EXHAUST



STEP 2—ADJUST NO. 5 INTAKE & EXHAUST  
STEP 3—ADJUST NO. 3 INTAKE & EXHAUST  
STEP 5—ADJUST NO. 2 INTAKE & EXHAUST  
STEP 6—ADJUST NO. 4 INTAKE & EXHAUST  
1421-A

FIG. 21—Preliminary Valve Lash Adjustment

The cylinders are numbered from front to rear, 1-2-3-4-5-6. The valves are arranged from front to rear, E-I-I-E-I-E-I-E-I-E.

### PRELIMINARY ADJUSTMENT

1. Turn all the valve adjusting screws until interference is noted between the screw and the rocker arm, then check the torque required to turn the screw further. If the torque required to turn a screw is less than 3 foot-pounds (36 inch pounds), try a new self locking adjusting screw. If this is still unsatisfactory, replace the rocker arm and adjusting screw.

2. Make two chalk marks on the crankshaft damper (Fig. 21). Space the marks approximately 120° apart so that with the timing mark, the damper is divided into three equal parts (120° represents 1/3 of the distance around the damper circumference).

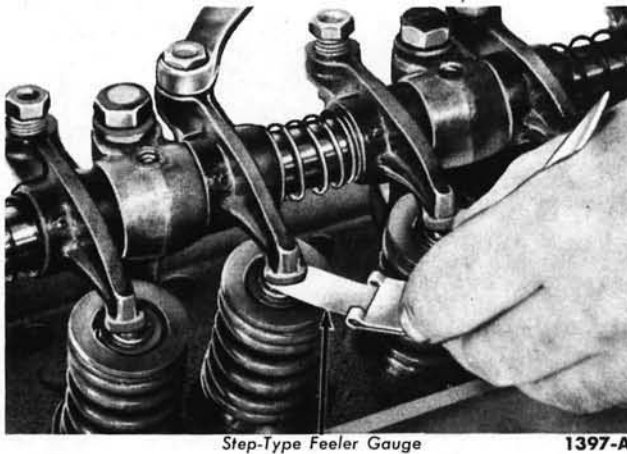
3. Rotate the crankshaft until No. 1 piston is near T.D.C. at the end of the compression stroke. Number 1 piston is on T.D.C. at the end of the compression stroke when both valves are closed and the timing mark on the crankshaft damper is in line with the timing pointer.

100% SATISFACTION GUARANTEED

**BUY IT NOW!**

Click Here To Order

PayPal American Express Discover/Novus MasterCard VISA



Step-Type Feeler Gauge

1397-A

FIG. 22—Valve Lash Adjustment

4. Using a step-type feeler gauge (“go” and “no go”), adjust the intake and exhaust valve lash for No. 1 cylinder (Fig. 22). The preliminary (cold) intake and exhaust valve lash should be set at 0.019 inch.

5. Repeat this procedure for the remaining set of valves, turning the crankshaft  $\frac{1}{8}$  turn at a time, in the direction of rotation, while adjusting the valves in the firing order sequence (1-5-3-6-2-4).

#### FINAL ADJUSTMENT

Operate the engine for a minimum of 30 minutes at approximately 1200 rpm to stabilize engine temperatures. With the engine idling, check the valve lash. Adjust the lash if necessary (Fig. 22). The final (hot) intake and exhaust valve lash should be 0.019 inch.

## 5 CRANKSHAFT DAMPER, CYLINDER FRONT COVER, AND TIMING CHAIN

### CRANKSHAFT DAMPER

#### REMOVAL

1. On a P-series truck, remove the hood, and remove the grille, headlamps, parking lamps, wind deflector, and hood lower weatherstrip as an assembly.
2. On all models, remove the radiator, fan, spacer, drive belt(s), and pulley.
3. On a B- or F-series truck, remove the grille to hood lock support bracket retaining bolt.
4. On all models, remove the cap screw and washer from the end of the crankshaft, then remove the damper (Fig. 23).

#### INSTALLATION

1. Lubricate the crankshaft with an oil and white lead mixture and lubricate the oil seal rubbing surface with grease.
2. Align the damper keyway with the key on the crankshaft, and start the damper on the shaft. Press the damper on the shaft (Fig. 24). Install the lockwasher and capscrew, then tighten the capscrew to 85-95 foot-pounds torque. Install the pulley, spacer and fan. Install and adjust the drive belts. Install the radiator and fill and bleed the cooling system.
3. On a B- or F-series truck, install the grille to hood lock support bracket retaining bolt.
4. On a P-series truck, install the grille, headlamps, parking lamps, wind deflector, and hood lower weatherstrip. Install the hood.

4. On a P-series truck, install the grille, headlamps, parking lamps, wind deflector, and hood lower weatherstrip. Install the hood.

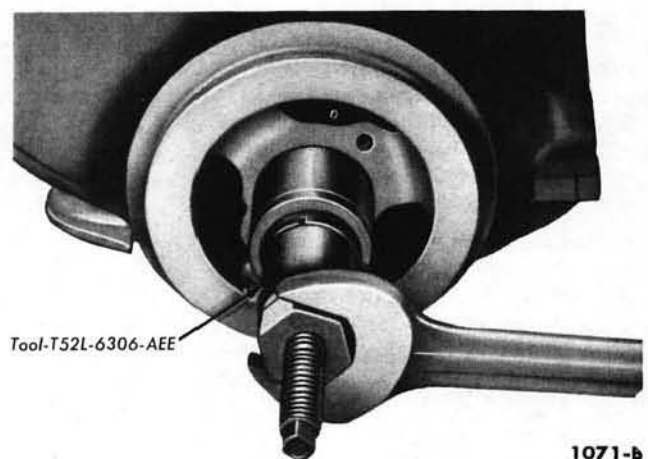
### CYLINDER FRONT COVER AND TIMING CHAIN

#### REMOVAL

1. Drain the cooling system and the crankcase. Remove the radiator, the crankshaft damper, and the oil pan. Remove the cylinder front cover retaining screws, then remove the cover and gasket.
2. Remove the crankshaft front oil slinger. Crank the engine until the timing marks are positioned as shown in Fig. 25. Remove the camshaft sprocket retaining bolt and washer.



1070-B



1071-b

FIG. 24—Damper Installation



**BUY IT NOW!**

**Click Here To Order**



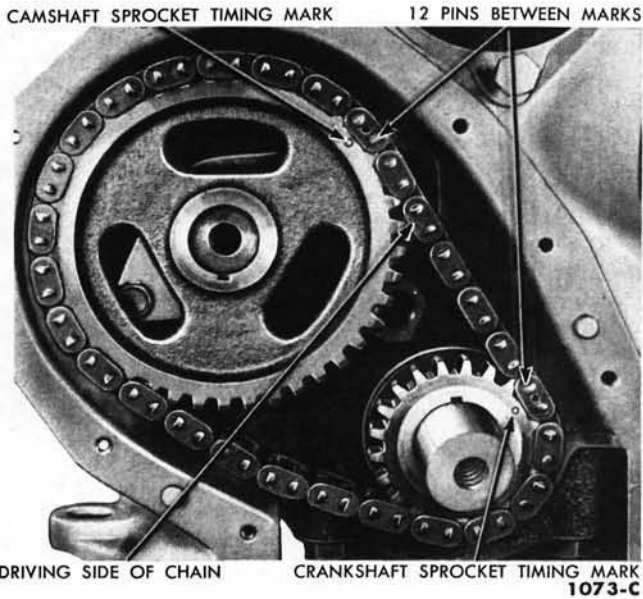


FIG. 25—Aligning Timing Marks

Slide both sprockets and the timing chain forward and remove them as an assembly.

**Oil Seal Replacement.** It is good practice to replace the oil seal each time the cylinder front cover is removed.

1. Drive out the old seal with a pin punch, then clean out the recess in the cover.

2. Coat a new seal with grease, then install the seal (Fig. 26). Drive the seal in until it is fully seated in the recess. Check the seal after installation to be sure the spring is properly positioned in the seal.

#### INSTALLATION

1. Place the keys in position in the slots on the crankshaft and camshaft.

2. Position the sprockets and timing chain on the camshaft and crankshaft. Be sure the timing marks on the sprockets and chain are positioned as shown in Fig. 25. There are 12 timing chain link pins between the timing marks on the sprockets.

3. Install the camshaft sprocket washer and retaining bolt. Tighten the bolt to 35-45 foot-pounds torque.

4. Rotate the crankshaft in a clockwise direction (as viewed from the front) until the slack on the left

side of the chain is taken up. Rotate the crankshaft in a clockwise direction until the slack on the right

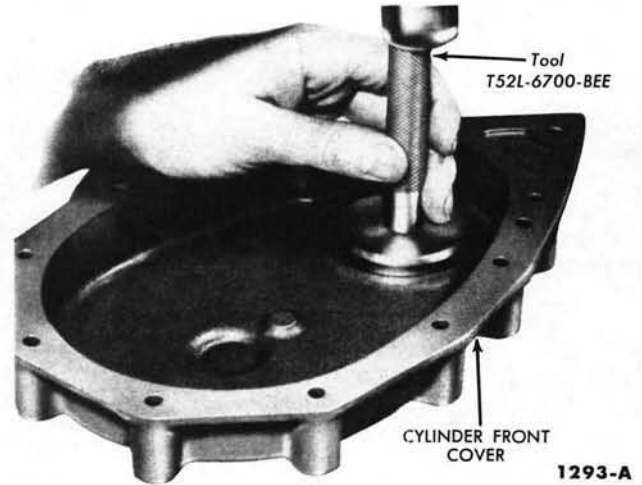


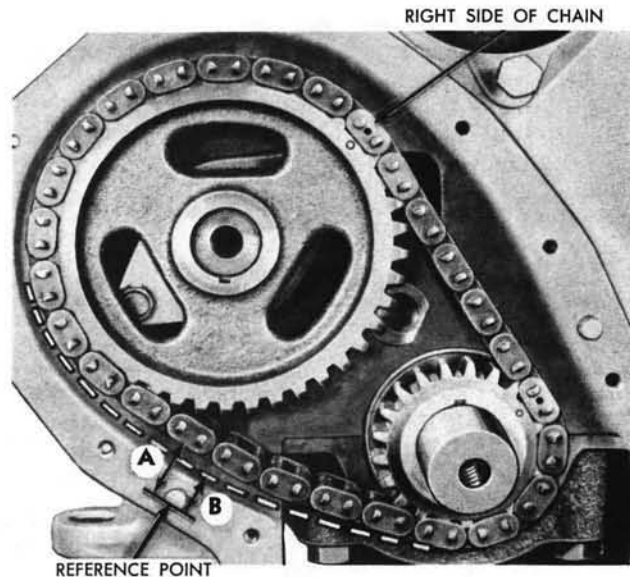
FIG. 26—Oil Seal Installation

left side of the chain out with the fingers and measure the distance between the reference point and the chain. The deflection is the difference between the two measurements. The deflection should not exceed 1/2 inch.

5. Clean the cylinder front cover and the gasket surface of the cylinder block. Coat the gasket surface of the block and the cover with sealer, then position a new gasket on the block.

6. Place the cover on the block and install the retaining screws. Tighten the screws to 6-9 foot-pounds torque.

7. Install the oil pan, the crankshaft damper, and drive belt(s). Install the radiator. Fill and bleed the cooling system. Fill the crankcase with the proper grade and quantity of engine oil. Operate the engine at fast idle and check all hose connections and gaskets for leaks.



TAKE UP SLACK ON LEFT SIDE. ESTABLISH A REFERENCE POINT AND MEASURE DISTANCE A. TAKE UP SLACK ON RIGHT SIDE AND FORCE LEFT SIDE OUT WITH THE FINGERS AND MEASURE DISTANCE B. DEFLECTION IS A MINUS B.

1398-B

FIG. 27—Timing Chain Deflection



**BUY IT NOW!**

**Click Here To Order**



## 6 CAMSHAFT, BEARINGS, AND TAPPETS

### CAMSHAFT

The camshaft and related parts are shown in Fig. 28.

#### REMOVAL

1. Drain the cooling system and the crankcase. Remove the air cleaner and tape the carburetor air horn closed. Remove the radiator.

2. Disconnect the high tension wire from the coil and disconnect the spark plug wires, then remove the distributor cap and wiring as an assembly. Disconnect the distributor vacuum line and the primary wire at the distributor. Remove the oil level dip stick and the fuel pump. Disconnect the water temperature sending unit wire at the sending unit and remove the wire from the retaining clips, then remove the push rod chamber cover.

3. Remove the valve rocker arm cover, the valve rocker arm shaft assembly, and the valve push rods in sequence. Remove the fan, spacer, and pulley. Remove the crankshaft damper, cylinder front cover, and crankshaft oil slinger.

4. Crank the engine until the timing marks on the sprocket and chains are positioned as shown in Fig. 25. Scribe a line on the distributor housing and cylinder block to mark the position of the rotor and distributor housing for installation, then remove the distributor.

5. Remove the camshaft sprocket bolt and washer, the sprockets and timing chain, the camshaft thrust plate, the woodruff key, and spacer.

6. Turn the camshaft until the tappets can be lifted with either a magnet (Fig. 29) or the fingers. Raise the tappets clear of the camshaft lobes and secure them with spring-type clothes pins or window regulator spring clips (Figs. 29 and 30).

7. Remove the oil pan. Install the engine lifting hook and raise the engine enough to relieve the tension on the engine support brackets, then remove the engine right and left front support bracket to cylinder block retaining bolts. Lower the engine enough to facilitate camshaft removal and remove the camshaft by pulling it toward the front of the engine. Exercise caution to avoid damaging the camshaft bearings.

#### INSTALLATION

1. Oil the camshaft and carefully slide it through the bearings. Install the thrust plate and spacer. **Be sure the chamfer on the inside of the spacer is to the rear or faces the camshaft journal.** Install the woodruff key in the camshaft.

2. Raise the engine enough to align it with the engine front support brackets. Install the right and left support bracket retaining bolts. Remove the engine lifting hook.

3. Install the sprockets and timing chain. Be sure the timing marks are properly aligned. Install the sprocket washer and bolt, then tighten the bolt to 35-45 foot-pounds torque.

4. Install the crankshaft oil slinger, the cylinder front cover, crankshaft damper, pulley, spacer, and fan. Install and adjust the drive belt(s). Install the oil pan.

5. Release the tappets and install the push rods, then install the valve rocker arm shaft assembly. Perform a preliminary valve lash adjustment. Cement a new gasket to the valve push rod chamber cover and install

the cover. Connect the water temperature sending unit wire to the sending unit and install the wire in the retaining clip.

6. If the crankshaft was rotated, crank the engine until the No. 1 piston is on T.D.C., then position the distributor in the block with the rotor at the No. 1 firing position and the breaker points open. Connect the distributor vacuum line and primary wire. Install the distributor cap and connect the spark plug wires and the coil high tension wires. Install the fuel pump and the oil level dip stick.

7. Remove the tape from the air horn and install the air cleaner. Install the radiator.

### BEARING REPLACEMENT

It will be necessary to remove the engine from the truck to replace camshaft bearings. The bearings are available pre-finished to size and require no reaming for standard and 0.015-inch undersize journal diameters. Number 3 bearing is not interchangeable with the other bearings.

1. Remove the engine from the chassis, then remove the camshaft. Drill a 1/2-inch hole in the center of the camshaft rear bearing bore plug and remove it as shown in Fig. 31. Remove the camshaft bearings (Fig. 32).

2. Position the bearing at the bearing bore and press it in place (Fig. 32). **Number 1 camshaft bearing must be pressed in 0.005-0.020 inch below the front face of the bearing bore. Press the remaining bearings in sufficiently to align the oil supply holes.**

BEARING (FRONT AND INT.) INT. BEARING REAR BEARING  
CAMSHAFT SPROCKET  
WASHER SPACER  
SCREW KEY CAMSHAFT

**100% SATISFACTION GUARANTEED**

**BUY IT NOW!**

**Click Here To Order**

PayPal American Express Discover Novus MasterCard VISA

1074-C

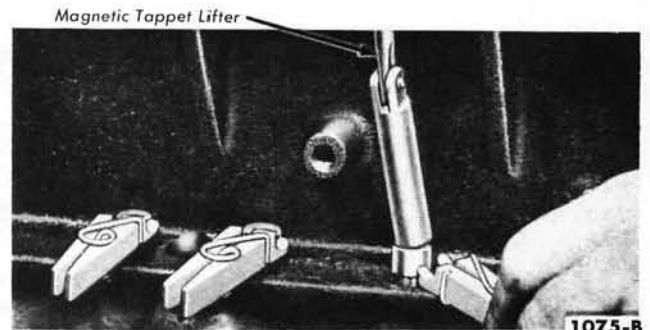


FIG. 29—Lifting and Securing Valve Tappets

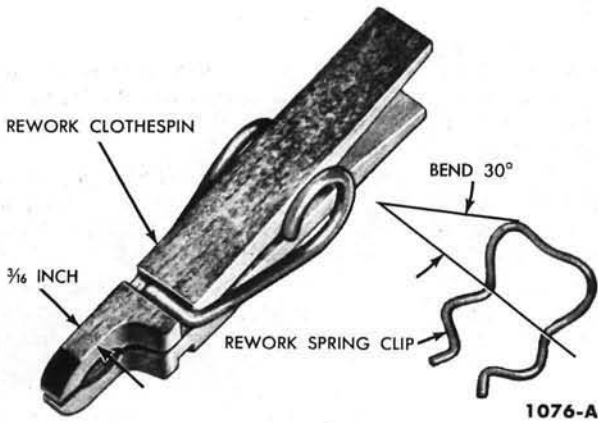


FIG. 30—Tappet Retainers

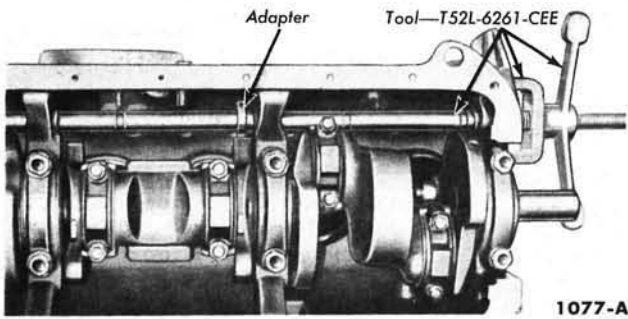


FIG. 32—Camshaft Bearing Replacement

3. Clean the camshaft rear bearing bore plug recess thoroughly. Coat the flange of a new plug with water resistant sealer and install it with the flange facing out (Fig. 33). Drive the plug in until the flange is flush or slightly below the casting surface. Install the camshaft and related parts. Install the engine in the chassis.

**TAPPET REPLACEMENT**

1. Remove the camshaft.

2. Remove and install one tappet at a time through the bottom of the block. A flexible-type holding tool can be used if desired. As each tappet is installed, secure it in the up position.

pet is installed, secure it in the up position.

3. After the tappets are installed, install the camshaft and related parts.

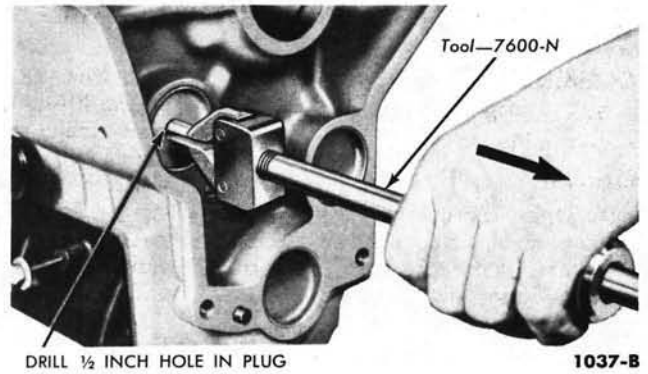


FIG. 31—Camshaft Rear Bearing Bore Plug Removal

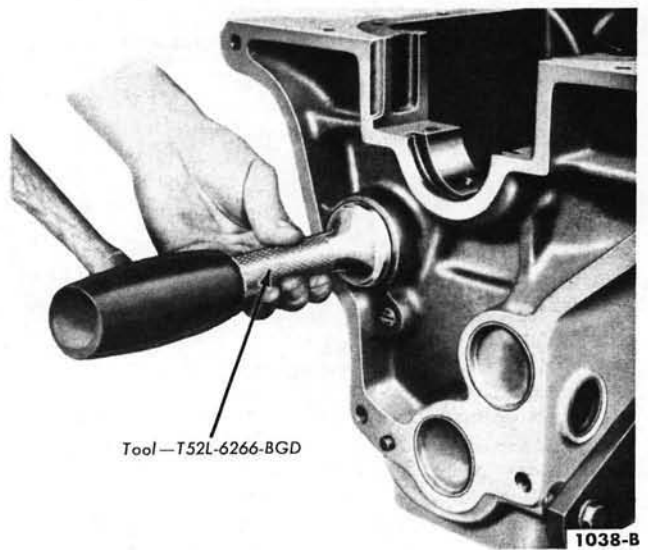


FIG. 33—Camshaft Rear Bearing Bore Plug Installation

**7 FLYWHEEL, CRANKSHAFT, CONNECTING RODS, AND PISTON ASSEMBLIES**

**FLYWHEEL**

Procedure for replacing the

shift transmission) or Group 4 (automatic transmission).

On a manual shift transmission, remove the pressure plate, and cover assembly and the clutch disc as outlined in Part 3-1.

Remove the flywheel retaining and remove the flywheel.

**RING GEAR REPLACEMENT—MANUAL—SHIFT TRANSMISSION FLYWHEEL**

Heat the defective ring gear with a blow torch on the engine side of the gear, then knock it off the flywheel. **Do not hit the flywheel when removing the ring gear.**

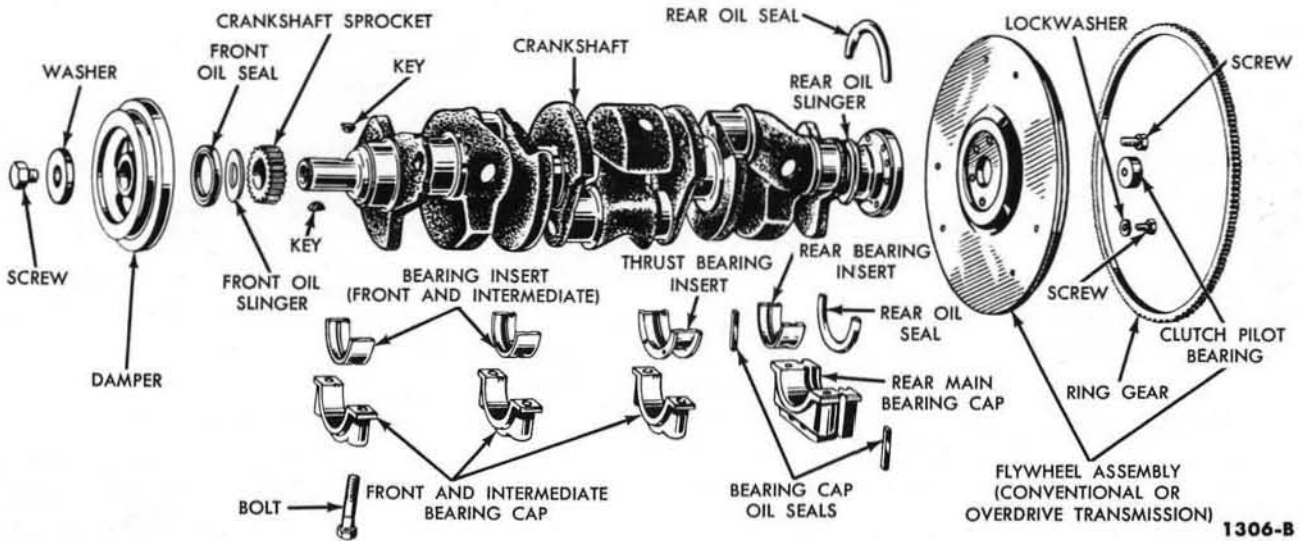
**100% SATISFACTION GUARANTEED**

**BUY IT NOW!**

**Click Here To Order**

FLYWHEEL

from rea



1306-B

FIG. 34—Crankshaft and Related Parts

Heat the new ring gear evenly until the gear expands enough to slip onto the flywheel. Make sure the gear is seated properly against the shoulder. **Do not heat any portion of the gear to a temperature higher than 500°F. If this limit is exceeded, the temper will be removed from the ring gear teeth.**

#### FLYWHEEL INSTALLATION

1. Position the flywheel on the crankshaft flange and install the mounting bolts. Tighten the bolts in sequence across from each other to specifications.

2. On a manual-shift transmission, install the clutch disc and the pressure plate and cover assembly as outlined in Part 3-1.

3. Connect the transmission to the engine as outlined in Group 3 (manual-shift transmissions) or Group 4 (automatic transmissions).

#### CRANKSHAFT

The crankshaft and related parts are shown in Fig. 34.

#### REMOVAL

Drain the cooling system and crankcase. Remove the engine

crankcase ventilation tube, oil pan, and the oil pump.

2. Make sure all bearing caps (main and connecting rod) are marked so they can be installed in their original locations. Remove the connecting rod bearing caps, using care not to intermix the caps, then push the pistons to the top of the cylinders. Remove the main bearing caps.

3. Carefully lift the crankshaft out of the block so the thrust bearing surfaces are not damaged. Remove the rear journal oil seal from the block and rear bearing cap, and remove the cap to block side seals.

4. If new main and/or connecting rod bearings are to be installed, remove the main bearing inserts from the block and the bearing caps, and/or the connecting rod bearing inserts from the connecting rod and cap. Install new bearings following the procedure in Section 8—"Main and Connecting Rod Bearing Replacement."

#### INSTALLATION

1. Be sure the bearings, crankshaft journals, and the rear journal oil seal grooves are clean. Install a new rear oil seal in the cylinder block (Fig. 35), and in the rear main bearing cap (Fig. 36). After installation, cut the ends of the seals flush.

2. Carefully lower the crankshaft to place. **Be careful not to damage the bearing surfaces.**

3. Check the clearance of each main bearing following the procedure under "Main Bearing Replacement" in Section 8. If the bearing clearances are satisfactory, apply a light coat of engine oil to the journals and bearings, then install all the bearing caps except the thrust bearing cap (No. 3 bearing). Tighten the bearing cap bolts to 95-105 foot-pounds torque. Dip the rear bearing cap side seals in light engine oil, then immediately install them in the grooves. **Do not use sealer on the side seals. The seals are designed to expand when dipped in oil. Using sealer may retard this expansion.** It may be necessary to tap the seals into place for the last 1/2 inch of travel. Do not cut the seal projecting ends. Check the side seals for leaks by squirting a few drops of oil into the parting lines between the rear bearing cap and the cylinder block from the outside. Blow compressed air against the seals from the inside of the block. If air bubbles appear in the oil, it indicates possible oil leakage. **The above test should not be performed on newly installed seals until sufficient time has been allowed for the seals to expand into the seal grooves.**

4. Install the thrust bearing cap with the bolts finger tight, then pry the crankshaft forward against the thrust surface of the upper half of the bearing (Fig. 37). Hold the crankshaft forward and pry the thrust bearing cap to the rear (Fig. 37). This will align the thrust surfaces of both halves of the bearing. Retain the for-

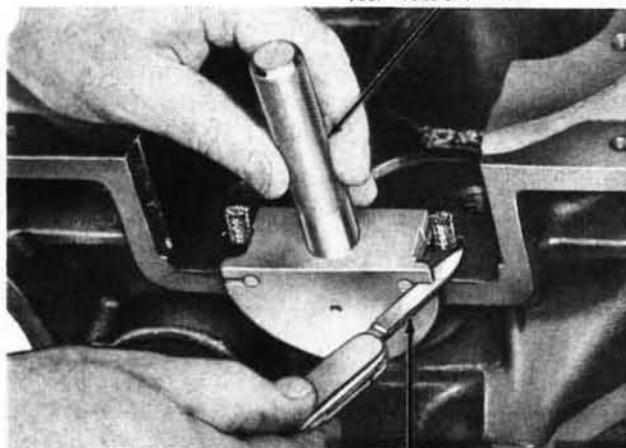
100% SATISFACTION GUARANTEED

**BUY IT NOW!**

Click Here To Order

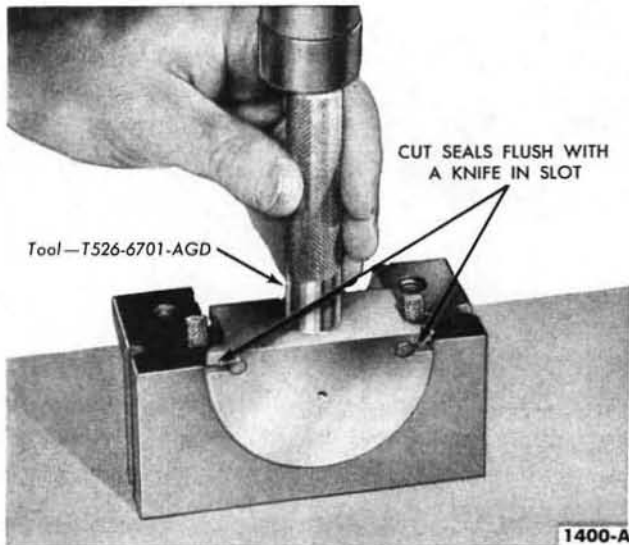
PayPal American Express Discover/Novus MasterCard VISA

Tool—T52L-6701-AGD



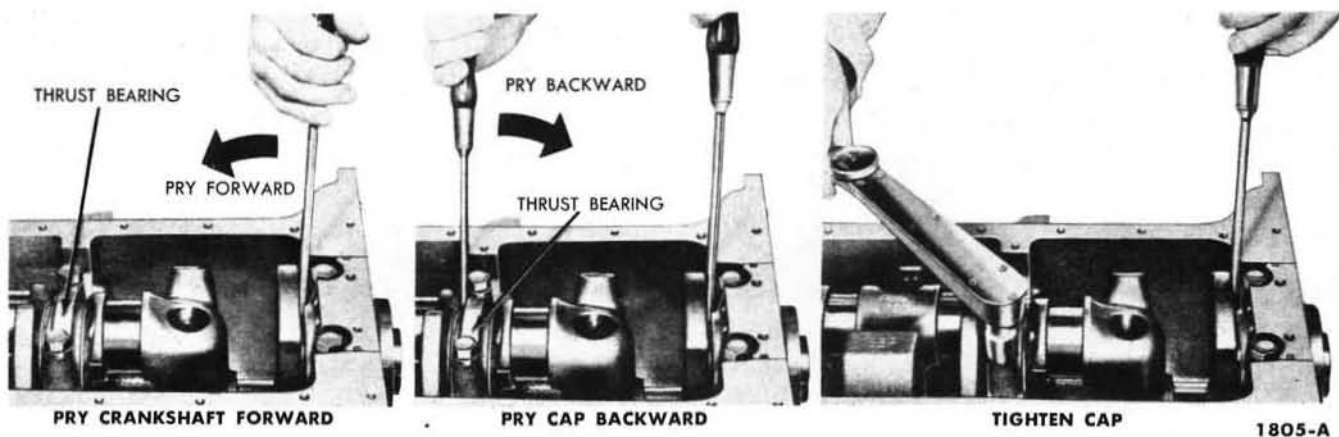
CUT SEALS FLUSH 1399-A

FIG. 35—Rear Oil Seal To Block Installation



1400-A

FIG. 36—Rear Oil Seal To Rear Bearing Cap Installation



1805-A

FIG. 37—Thrust Bearing Alignment

ward pressure on the crankshaft and tighten the cap bolts to 95-105 foot-pounds torque (Fig. 37).

5. Force the crankshaft toward the rear of the engine. Install a dial indicator so the contact point rests against the crankshaft flange and the indicator axis is parallel to the crankshaft axis (Fig. 38). Set the dial on zero, then push the crankshaft forward. Note the reading on the dial.

dirty, they probably were not aligned properly. Install the thrust bearing and align the faces following the recommended procedure, then recheck the end play.

6. Check the clearance of each connecting rod bearing following the procedure under "Connecting Rod Bearing Replacement" in Section 8. If the bearing clearances are satisfactory, apply a light coat of engine oil to the journals and bearings, then install the connecting rod caps. Tighten nuts to 45-50 foot-pounds torque. Check the side clearance between the connecting rods on each crankpin following the procedure under "Piston and Connecting Rod Installation."

7. Install the flywheel, oil pump, oil pump screen and inlet tube assembly, crankshaft damper key, and the oil pan.

8. Install the sprockets and timing chain with the timing marks aligned (Fig. 25). Install the crankshaft front oil slinger, cylinder front cover, and the crankshaft damper. Install the water pump, distributor, crankcase ventilation tube, oil level dip stick, pulley, and fan. Install the generator, then install and adjust the drive belt.

9. Install the engine in the chassis. Fill and bleed the cooling system. Fill the crankcase with the proper grade and quantity of engine oil. Start the engine and check and adjust the ignition timing. Operate the engine at fast

**100% SATISFACTORY GUARANTEED**

**BUY IT NOW!**

**Click Here To Order**

PayPal    American Express    Discover    MasterCard    VISA

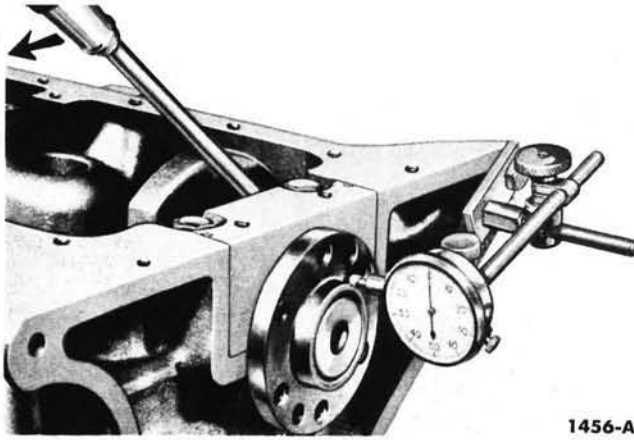


FIG. 38—Crankshaft End Play

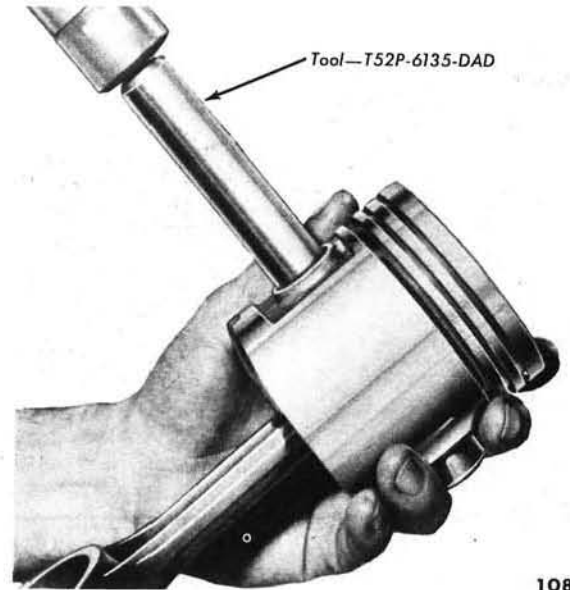


FIG. 40—Piston Pin Removal

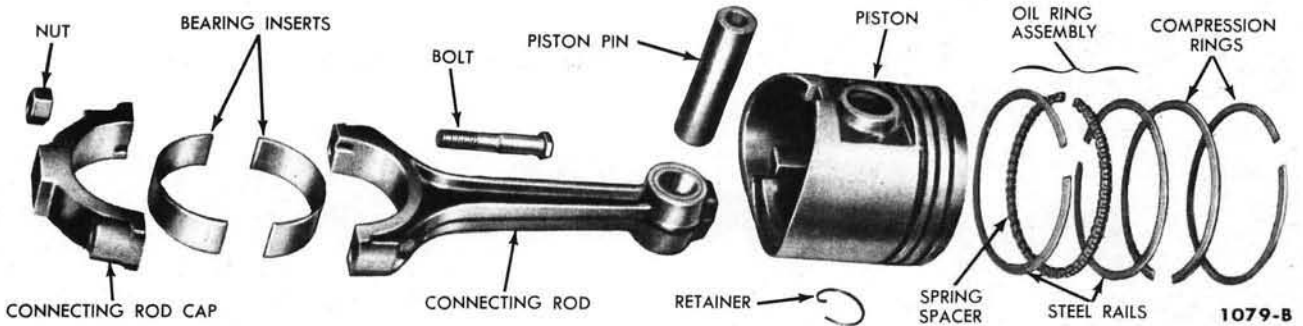


FIG. 39—Piston and Connecting Rod Assembly

idle and check for oil pressure and check all hose connections and gaskets for leaks.

**PISTON AND CONNECTING ROD REMOVAL**

The piston and connecting rod assembly is shown in Fig. 39.

1. Drain the cooling system and the crankcase. Remove the air cleaner, then tape the air horn closed. Remove the cylinder head, oil level dip stick, crankcase ventilation tube, flywheel housing inspection cover, oil pan, and the oil pump screen and tube.

cuttings. Remove the cylinder ridge with a ridge cutter. **Never cut into the ring travel area in excess of 1/32 inch when removing ridges.** After the ridge has been removed, remove the cutter from the cylinder bore, then turn the crankshaft until the piston is at the top of its stroke and carefully remove the cloth with the cuttings.

3. Turn the crankshaft until the connecting rod being removed is down. Remove the hex head nuts from the connecting rod bolts. Pull the cap off the rod, then push the rod and piston assembly out the top of the cylinder with the handle end of a hammer. **Avoid damage to the crankpin or the cylinder wall when removing the piston.**

4. If new piston rings are to be installed and the cylinder has not been finished, remove the glaze from the

cylinder wall by passing a fine grit hone or glaze removal tool through the bore a few times. **Take all the necessary precautions to catch the grit.** Do not hone more than enough to rough up the finish. Thoroughly clean the cylinder walls and the block after the glaze is removed, then oil the walls.

5. Repeat the above procedure on each assembly.

**PISTON AND CONNECTING ROD DISASSEMBLY**

Mark the pistons and pins to assure assembly with the same rod and installation in the same cylinder from which they were removed. Remove the piston rings. Remove the piston pin retainers, then drive the pin out of the piston and rod (Fig. 40). Discard the retainers.

**100% SATISFACTION GUARANTEED**

**BUY IT NOW!**

**Click Here To Order**

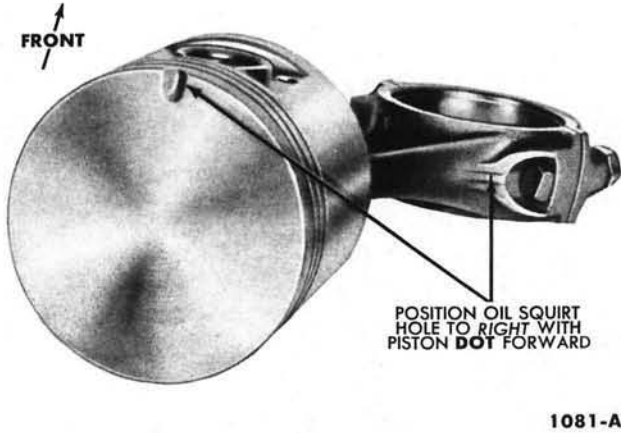


FIG. 41—Correct Position of Oil Squirt Hole

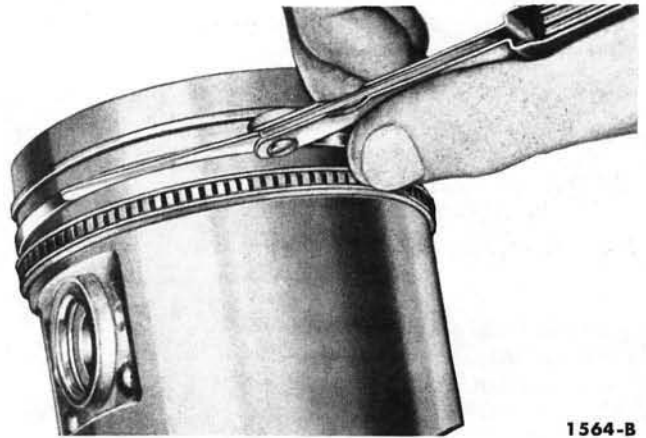


FIG. 42—Piston Ring Side Clearance

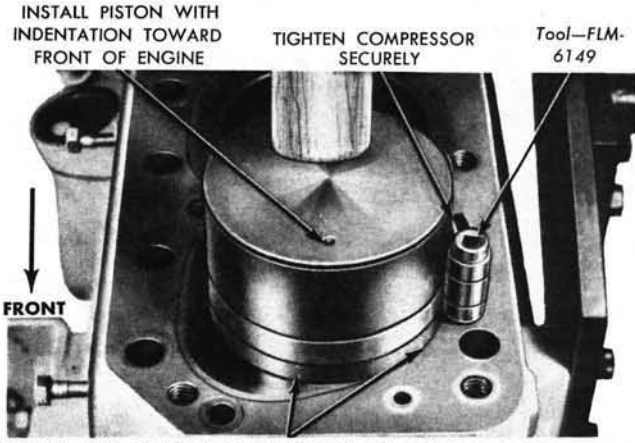


FIG. 43—Piston Installation

**PISTON AND CONNECTING ROD ASSEMBLY**

1. Lubricate all parts with light engine oil. Position the connecting rod in the piston and push the pin into place. Assemble the piston and connecting rod with the oil squirt hole in the rod positioned as shown in Fig. 41.

2. Insert new piston pin retainers by spiraling them into position with the fingers. Do not use pliers. Follow the instructions contained on the piston ring package and install the piston ring compressor with retainer toward skirt

Any wear that occurs will form a step at the inner portion of the lower land. If the lower lands have high steps, the piston should be replaced.

4. Be sure the bearings and journals are clean. If it is necessary to replace the connecting rod bearings, replace them at this time following the procedure under "Connecting Rod Bearing Replacement" in Section 8.

**PISTON AND CONNECTING ROD INSTALLATION**

Be sure to install the pistons in the same cylinder from which they were removed, or to which they were fitted. Each connecting rod and bearing is numbered from 1 to 6 beginning at the front of the engine. The nuts on the connecting rod and connecting rod cap must be on the same side

when installed in the cylinder bore. If a connecting rod is ever transposed from one block or cylinder to another, new bearings should be fitted, and the rod should be numbered to correspond with the new cylinder number.

1. Oil the piston rings, pistons, and cylinder walls with light engine oil.

2. Make sure the ring gaps are properly spaced around the circumference of the piston. Install a piston ring compressor on the piston and push the piston in with the handle end of a hammer until it is slightly below the top of the cylinder (Fig. 43). Be sure to guide the connecting rods to avoid damaging the crankshaft journals. Install the piston with the indentation in the piston head toward the front of the engine.

3. Check the clearance of each bearing following the procedure under "Connecting Rod Bearing Replacement" in Section 8. If the bearing clearances are to specifications, apply a light coat of engine oil to the journals and bearings.

4. Turn the crankshaft throw to the bottom of its stroke, then push the piston all the way down until the connecting rod bearing seats on the crankshaft journal. Install the connecting rod cap, then tighten the nuts to 45-50 foot-pounds torque.

**100% SATISFACTION GUARANTEED**

**BUY IT NOW!**

**Click Here To Order**

PayPal, American Express, Discover, MasterCard, VISA

5. After all the piston and connecting rod assemblies have been installed, check the side clearance between the connecting rods on each crankshaft journal (Fig. 44).

6. Install the oil pump screen and inlet tube, oil pan, flywheel housing inspection cover, crankcase ventilation tube, oil level dip stick, and the cylinder head and related parts. Make a preliminary valve lash adjustment. Fill and bleed the cooling system and fill the crankcase.

7. Start the engine and operate it for a minimum of 30 minutes at approximately 1200 rpm. Check the valve lash with the engine idling and adjust it if necessary. Make sure there is sufficient oil pressure and the engine does not overheat. Check for oil and coolant leaks. Install the valve rocker arm cover and the air cleaner.

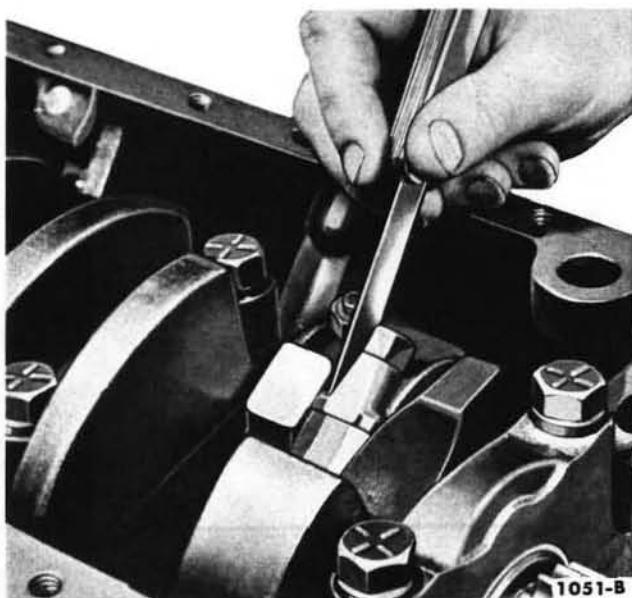


FIG. 44—Connecting Rod Side Clearance

## 8 MAIN AND CONNECTING ROD BEARING REPLACEMENT

The main and connecting rod bearing inserts are selective fit and do not require reaming to size upon installation. **Do not file or lap bearing caps or use shims to obtain the proper bearing clearance.**

Selective fit bearings are available for service in standard sizes only. Standard bearings are divided into two sizes and are identified by a daub of red or blue paint. **Red marked bearings increase the clearance; blue marked bearings decrease the clearance.** Undersize bearings, which are not selective fit, are available for use on journals that have been refinished.

Normally, main bearing journals wear evenly and are not out-of-round. However, if a bearing is being fitted to an out-of-round journal, be sure to fit the bearing to the maximum diameter of the journal. If the bearing is fitted to the minimum diameter with minimum clearance, interference may result, causing an early failure. It is not recommended that bearings be fitted to a crankshaft journal which exceeds the maximum out-of-round specification. When re-

dirty may distort the bearing and cause bearing failure.

### MAIN BEARING REPLACEMENT

The following procedure is for the engine installed in the chassis. If the engine is on a work stand, omit step 1, follow steps 2-5. In step 4, if the engine is on a work stand, it is not necessary to support the crankshaft because the engine will be inverted. Also place the Plastigage on the crankshaft journal instead of on the bearing surface (Fig. 45) if the engine is on a work stand.

1. Drain the crankcase. Remove the distributor, oil level dip stick, crankcase ventilation tube, flywheel housing inspection cover, oil pan, and the oil pump.

2. Replace one bearing at a time, leaving the other bearings securely fastened. Remove the main bearing cap to which new bearings are to be fitted. Insert the upper bearing removal tool (tool 6331) in the oil hole in the crankshaft. Rotate the crankshaft in the direction of engine rotation to force the bearing out of the block.

3. To install the upper main bearing, place the plain end of the bearing over the shaft on the locking tang side of the block. Insert tool 6331 in the oil hole in the crankshaft and rotate the crankshaft in the opposite direction of engine rotation until the bearing seats itself. Remove the tool. Replace the cap bearing. Clean the crankshaft journal and bearings.

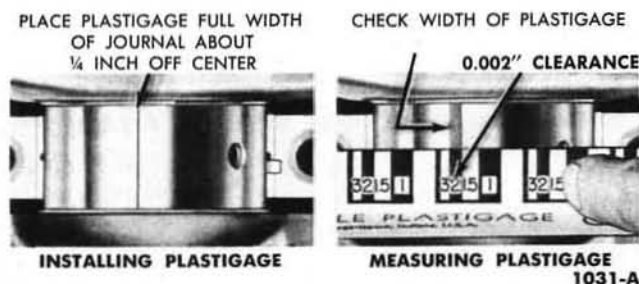


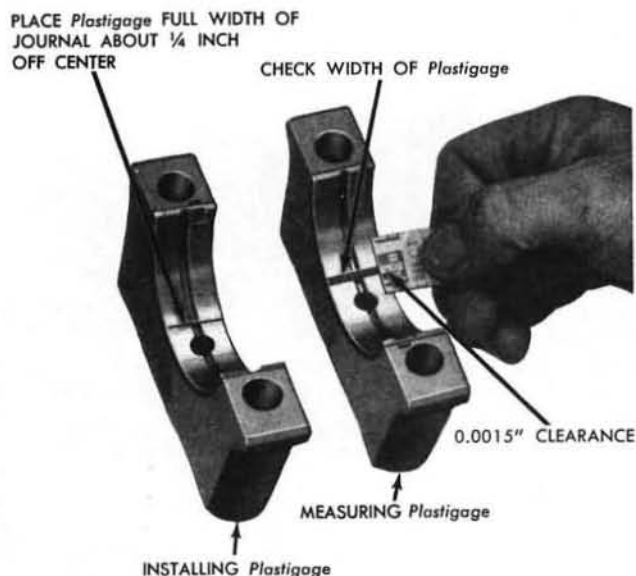
FIG. 45—Installing and Measuring Plastigage—Engine on Work Stand



**BUY IT NOW!**

**Click Here To Order**





1558-B

**FIG. 46—Installing and Measuring Plastigage—  
Engine in Chassis**

4. Support the crankshaft so its weight will not compress the Plastigage and provide an erroneous reading. Position a small jack so it will bear against the counterweight adjoining the bearing which is being checked. Place a piece of Plastigage on the bearing surface (Fig. 46) the full width of the bearing cap and tighten the bolts to 95-105 foot-pounds torque. **Do not turn the crankshaft while the Plastigage is in place.** Remove the cap, then using the Plastigage scale, check the width of the Plastigage (Fig. 46) at the widest point in order to get the minimum clearance. Check the Plastigage at the narrowest point in order to get the maximum clearance. The difference between the two readings is the taper.

If the clearance is less than the specified limits, try two red bearing halves or a combination of red and blue depending upon the condition. If the standard bearings do not bring the clearance within the desired limits, refinish the crankshaft journal, install undersize bearings.

95-105 foot-pounds torque.

6. If the rear main bearing is replaced, replace the lower oil seal (in the cap) and the side seals. The upper oil seal can not be replaced unless the crankshaft is removed from the engine.

7. Install the oil pump, oil pump screen and inlet tube assembly, oil pan, flywheel housing inspection cover, crankcase ventilation tube, and oil level dip stick. Crank the engine until the No. 1 piston is on T.D.C., then position the distributor in the block with the rotor at the No. 1 firing position and the breaker points open. Install the distributor hold down clamp. Fill the crankcase.

8. Start the engine and check and adjust the ignition timing. Operate the engine at fast idle and check for oil pressure and oil leaks.

#### CONNECTING ROD BEARING REPLACEMENT

1. Drain the crankcase. Remove the oil level dip stick, distributor, crankcase ventilation tube, flywheel housing inspection cover, oil pan, and oil pump screen and inlet tube. Remove the cap from the connecting rod to which new bearings are to be installed and remove the bearing in-

sert. Push the piston up in the cylinder, then remove the bearing insert from the connecting rod. Clean the crankshaft journal, the cap, and the upper half of the bearing bore.

2. Install the new bearings in the connecting rod and cap.

Pull the connecting rod assembly down firmly on the crankshaft journal. Place a piece of Plastigage on the lower bearing surface, the full width of the cap and about 1/4 inch off center. Install the cap and tighten the connecting rod nuts to 45-50 foot-pounds torque. **Do not turn the crankshaft while the Plastigage is in place.**

3. Remove the cap, then using the Plastigage scale check the width of the Plastigage at the widest point in order to get the minimum clearance. Check the Plastigage at the narrowest point in order to get the maximum clearance. The difference between the two readings is the taper.

If the clearance is less than the specified limits, try two red bearing halves or a combination of red and blue depending upon the condition. If the standard bearings do not bring the clearance within the desired limits, refinish the crankshaft journal, then install undersize bearings.

After the bearing clearance has been checked and found to be satisfactory, apply a light coat of engine oil to the crankshaft journal and bearings, then install the connecting rod cap. Tighten the nuts to 45-50 foot-pounds torque.

4. Repeat the procedure for the remaining connecting rods that require new bearings.

5. After all the bearings that required replacement have been replaced, install the oil pump screen and inlet tube, oil pan, flywheel housing inspection cover, crankcase ventilation tube, and oil level dip stick. Crank the engine until the No. 1 piston is on T.D.C., then position the distributor in the block with the rotor at the No. 1 firing position and the breaker points open. Install the distributor hold down clamp. Fill the crankcase, then operate the engine and check for oil pressure and oil leaks.



**BUY IT NOW!**

**Click Here To Order**



## 9 OIL PAN, OIL PUMP, AND OIL FILTER

### OIL PAN

#### REMOVAL

Drain the crankcase. Remove the oil level dip stick and the flywheel housing cover. Remove the oil pan retaining screws and remove the pan and gasket.

#### INSTALLATION

1. Make sure the gasket surfaces of the block and oil pan are clean and free from burrs. Coat the block surface and oil pan gasket surface with sealer and position the gasket on the oil pan.

2. Hold the oil pan in place against the block and install a screw, finger tight, on each side of the oil pan near the center. Install the remaining screws, then tighten the screws from the center outward in each direction to 12-15 foot-pounds torque.

3. Install the flywheel housing cover and the oil level dip stick.

4. Fill the crankcase with the proper grade and quantity of engine oil. Operate the engine and check for oil leaks.

### OIL PUMP

The oil pump is shown in Fig. 47.

#### REMOVAL

1. Remove the distributor, oil level dip stick, and the oil pan.

2. Remove the two nuts and lockwashers retaining the oil pump to the cylinder block, then remove the pump and gasket.

3. Thoroughly clean the old gasket material from the mounting pad on the block and pump.

#### DISASSEMBLY

1. Remove the oil pump cover, inlet tube assembly and gaskets from the oil pump. Remove the snap wire retaining the screen in the inlet tube assembly and remove the screen.

2. Push the oil pump drive shaft and drive gear assembly from the pump housing. Remove the driven gear.

3. Remove the oil pressure relief valve chamber plug, spring, and plunger.

#### ASSEMBLY

1. Apply a light coat of engine oil to all moving parts.

2. Install the pressure relief valve plunger, spring, and plug. Tighten the plug to 33-38 foot-pounds torque.

3. Slide the drive gear and shaft assembly into the housing. Install the driven gear. Check the end play of the gears (Part 1-1).

4. Apply sealer to both sides of the oil pump cover gasket, then position the gasket on the oil pump. In-

stall the oil pump cover.

5. Install the screen in the inlet tube assembly and secure it with the snap wire.

6. Install the inlet tube gasket, and the inlet tube assembly on the oil pump cover. Tighten the retaining screws to 12-15 foot-pounds torque. Rotate the pump shaft by hand to make sure it turns freely.

#### INSTALLATION

1. Place a new gasket on the retaining bolts, slide the pump mounting flange over the retaining bolts, and install the lockwashers and nuts. Tighten the nuts to 30-35 foot-pounds torque. Install the distributor and the oil pan and related parts.

2. Fill the crankcase and operate the engine at fast idle and check for oil pressure and oil leaks.

### OIL FILTER REPLACEMENT

#### REMOVAL

Place a drip pan under the filter. Remove the filter center bolt, then remove the filter assembly and gasket.

#### DISASSEMBLY

1. Remove the filter element, neoprene gasket, spring and seat, then remove the center bolt from the container and the fiber gasket from the bolt (Fig. 48).

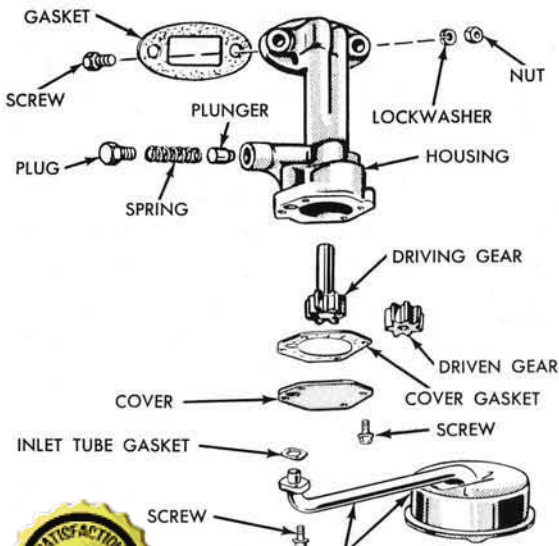
2. Discard the filter element and all gaskets. Wash all parts in solvent. Make sure all openings in the center bolt are clean.

#### ASSEMBLY

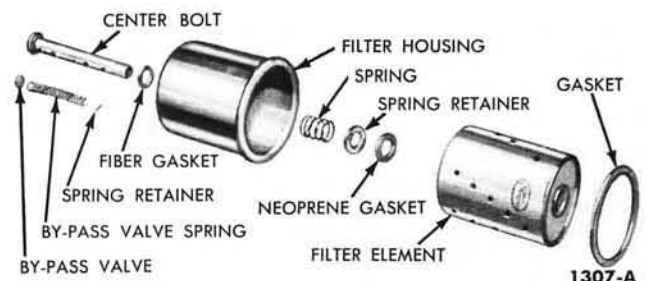
1. Install a new fiber gasket on the center bolt, then place the bolt through the filter container.

2. Install the spring and spring seat assembly on the bolt, making sure the seat tangs are engaged in the spring.

3. Install a new neoprene gasket and new filter element over the center bolt.



1085-C



1307-A

FIG. 48—Oil Filter Disassembled



**BUY IT NOW!**

**Click Here To Order**



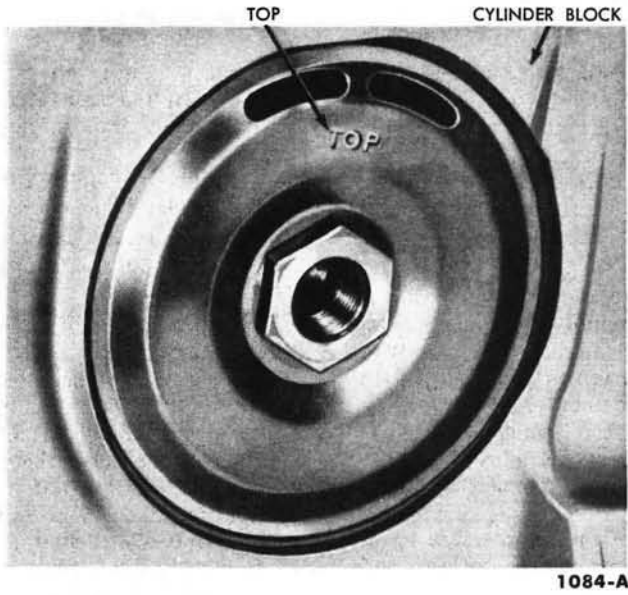


FIG. 49—Anti-Drain Back Diaphragm Position

#### INSTALLATION

1. Make sure the two elongated holes in the oil filter anti-drain back diaphragm are in the up position (Fig. 49).

2. Clean the cylinder block filter recess, then install a new gasket.

3. Place the filter assembly in position, and thread the center bolt into the adapter finger-tight. Rotate the filter assembly slightly, in each direction, to make sure the gasket is seated evenly. Tighten the center bolt to 20-25 foot-pounds torque. **Do not over tighten the center bolt.**

4. Refill the crankcase with oil if necessary, then operate the engine at fast idle and check for oil leaks. If oil leaks are evident, perform the necessary repairs to correct the leakage.

## 10 EXHAUST SYSTEM

The exhaust system consists of a muffler and inlet pipe assembly, and a muffler outlet pipe. The muffler and inlet pipe assembly are used in production only. A separate muffler and inlet pipe are used for service replacement. **When replacing any part of the exhaust system, loosen all the frame attaching bracket clamps to relieve twists in the system, then tighten the clamps.**

#### INLET PIPE AND MUFFLER REPLACEMENT

1. Loosen all outlet pipe clamps,

then slide the outlet pipe to the rear.

2. Remove the inlet pipe to manifold retaining nuts, then remove the inlet pipe and muffler assembly. Remove the gasket from the exhaust manifold.

3. Position a new service inlet pipe on the exhaust manifold using a new gasket. Install the retaining nuts, then tighten the nuts to 23-28 foot-pounds torque.

4. Place the muffler clamp on the inlet pipe, then position a new muffler on the inlet pipe. Install and tighten the clamp. Slide the outlet pipe into

the muffler and tighten the outlet pipe to muffler clamp. Tighten the outlet pipe support clamps.

#### OUTLET PIPE REPLACEMENT

1. Loosen the outlet pipe clamp at the muffler. Remove the outlet pipe support clamps, then pull the outlet pipe off the muffler.

2. Position the muffler clamp on the new outlet pipe, then slide the pipe on the muffler. Install, but do not tighten the support clamps. Tighten the outlet pipe to muffler clamp, then tighten the support clamps.

**100% SATISFACTION GUARANTEED**

**BUY IT NOW!**

**Click Here To Order**

# PART 1-3

## MEDIUM AND HEAVY DUTY V-8 ENGINES

Section	Page
1 Description.....	1-42
2 Engine Removal and Installation.....	1-46

Section	Page
3 Engine Supports.....	1-49
4 Manifolds, Cylinder Heads, and Valves.....	1-50

Section	Page
5 Crankshaft Damper, Cylinder Front Cover, and Timing Chain and Gears....	1-50
6 Camshaft, Bearings and Tappets.....	1-59
7 Flywheel, Crankshaft, Connecting Rods, and Piston Assemblies.....	1-63
8 Main and Connecting Rod Bearing Replacement.....	1-68
9 Oil Pan, Oil Pump, and Oil Filter.....	1-70
10 Exhaust System.....	1-71

The medium duty V-8 engine (292 cubic inch displacement) will be referred to as an MD V-8 engine and the heavy duty V-8 engines (292, 302,

and 332 cubic inch displacement) will be referred to as HD V-8 engines.

The service procedures given here

are for the engine installed in the chassis unless otherwise noted. Cleaning, inspection, repair, and overhaul procedures are covered in Part 1-1.

### 1 DESCRIPTION

The MD and HD V-8 engines (Figs. 1, 2, and 3) have the same basic design. The differences between the engine models and their application are listed in Table 1.

#### MANIFOLDS

The intake manifold contains a passage through the center section and under the carburetor, through which hot exhaust gases are directed to assist in vaporizing the incoming fuel charge.

On the MD V-8 engine, the exhaust gases are directed into the intake manifold by a thermostatically controlled exhaust valve (Fig. 4). The valve is located between the crossover pipe and the inlet of the right exhaust manifold. When the valve is closed or in the "heat on" position part of the exhaust gases are directed from the left exhaust manifold, through the heat riser passage, to the right ex-

haust manifold (Fig. 5). When the valve opens "heat off," more of the exhaust gases from the left manifold are permitted to flow directly out the exhaust system in the normal manner.

The intake manifold has two sets of fuel passages, each with its own separate inlet connection to the carburetor (Fig. 6). The right barrel(s) of the carburetor feeds Nos. 2, 3, 5, and 8 cylinders, and the left barrel(s) feeds Nos. 1, 4, 6, and 7 cylinders.

A 292 HD V-8 engine, when installed in a C-series truck, and all 302 and 332 HD V-8 engines have ram's horn-type exhaust manifolds. The exhaust manifolds are interchangeable between engines and between either side of the engine.

The 292 MD and HD V-8 engines when installed in a B-F-T-series truck have conventional-type exhaust manifolds.

#### CYLINDER HEADS

The cylinder head assemblies contain the valves and the valve rocker arm shaft assembly. Valve guides are an integral part of the head. The intake and exhaust valve seats of the 302 and 332 HD V-8 engines and the exhaust valve seats of the 292 HD V-8 engine are the insert type. The valves are arranged from front to rear on both banks E-I-I-E-E-I-I-E.

#### CYLINDER BLOCK

The cylinders are numbered from front to rear on the right bank 1, 2, 3, and 4 and on the left bank 5, 6, 7, and 8. The firing order is 1-5-4-8-6-3-7-2.

The oil pump is mounted externally on the left rear of the block. The distributor is located on the right rear of the engine and drives the oil pump through an intermediate drive shaft.

The crankshaft used in the 292 en-

TABLE 1—Engine Model Application

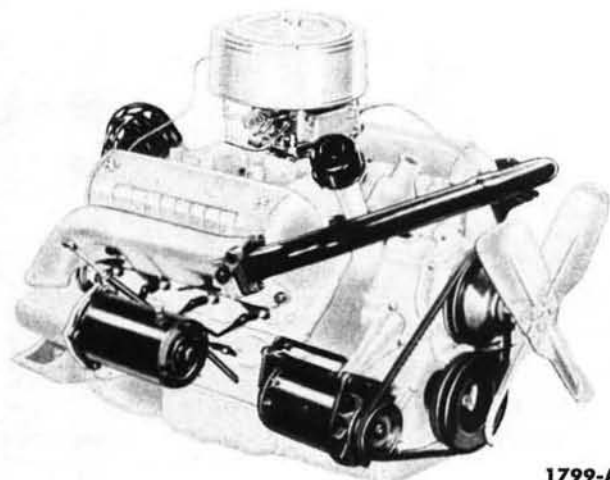
Patent Plate Code	Engine	Cubic Inch Displ.	Comp. Ratio	Carb.	Gov.	Dist.	Truck Model Application
C	Medium Duty V-8	292	7.9:1	2-Barrel	Velocity*	Dual Advance	C-550, 600; B-C-F-T-700; P series; F-100 thru 600; B-500, 600*
	Heavy Duty V-8	292	7.6:1	4-Barrel	Vacuum	Centrifugal Advance	F-B-C-T-700; C-550,* 600* F-B-500,* 600*
			7.5:1	4-Barrel	Vacuum	Centrifugal Advance	B-C-F-750; T-700*
			7.5:1	4-Barrel	Vacuum	Centrifugal Advance	T-750; C-F-T-800



**BUY IT NOW!**

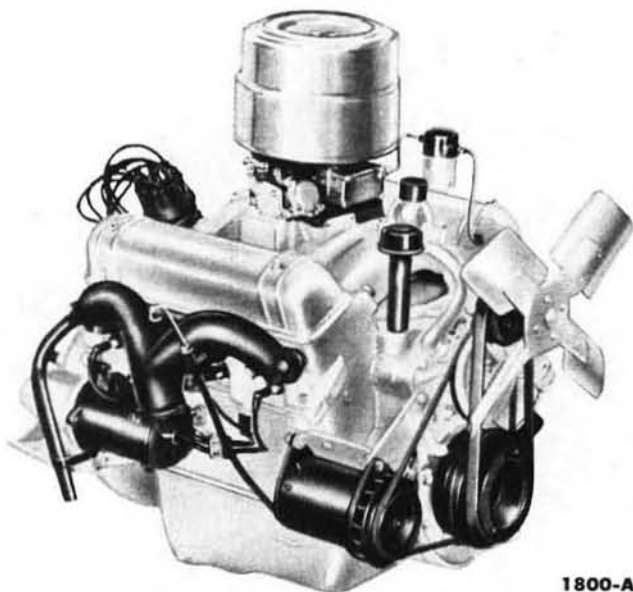
Click Here To Order





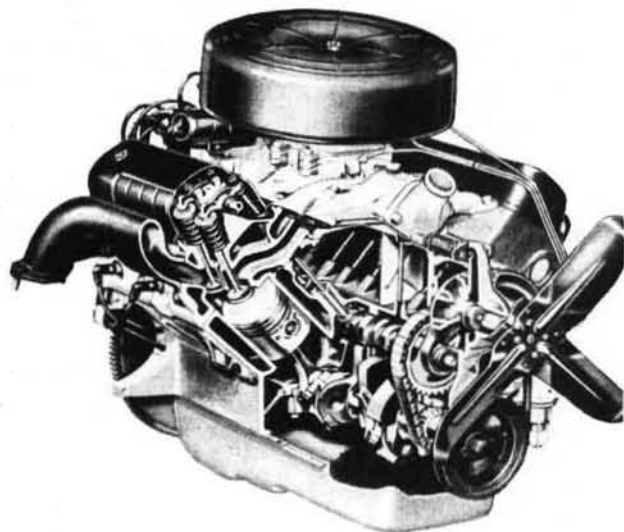
1799-A

FIG. 1—MD V-8 Engine—Typical



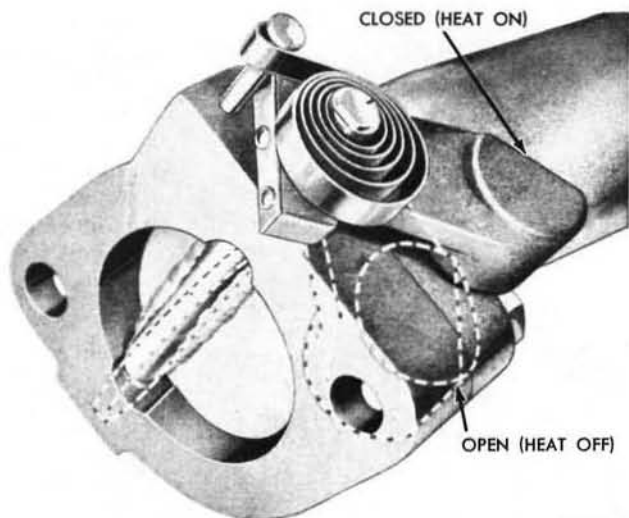
1800-A

FIG. 2—HD V-8 Engine—Typical



1415-B

FIG. 3—MD or HD V-8 Engine Sectional View—Typical



1001-A

FIG. 4—Exhaust Gas Control Valve—292 MD V-8

gine is made from a cast iron alloy, while the 302 and 332 engines have a forged steel crankshaft. The crankshaft is supported by five insert-type bearings. Crankshaft end thrust is controlled by the flanges of the No. 3 main bearing.

The top compression ring of the piston is chrome-plated and the lower ring is phosphate coated.

#### VALVE TRAIN

The intake and exhaust valve assemblies used in the MD V-8 engine and the intake valves of the HD V-8 engines are the rotating-type.

Easy maintenance of valve lash is afforded by self locking adjusting screws.

The camshaft is supported by five insert-type bearings pressed into the block.

The camshaft in the 292 engine is driven by a sprocket and timing chain with a sprocket on the crank-

shaft. A single strand chain is used on the MD V-8 engine and a double strand chain is used on the HD V-8 engine.

The camshaft in the 302 and 332 engines is driven by a gear in mesh with a gear on the crankshaft.

#### LUBRICATION SYSTEM

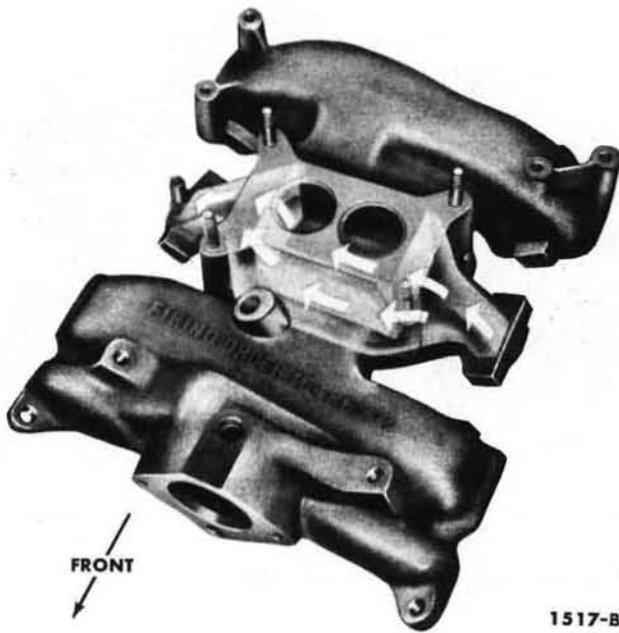
Oil from the oil pan sump is forced through the pressure-feed lubrication system (Fig. 7) by a rotor-type pump. A spring loaded relief valve in the pump limits the maximum pressure of the system.

**100% SATISFACTION GUARANTEED**

**BUY IT NOW!**

**Click Here To Order**

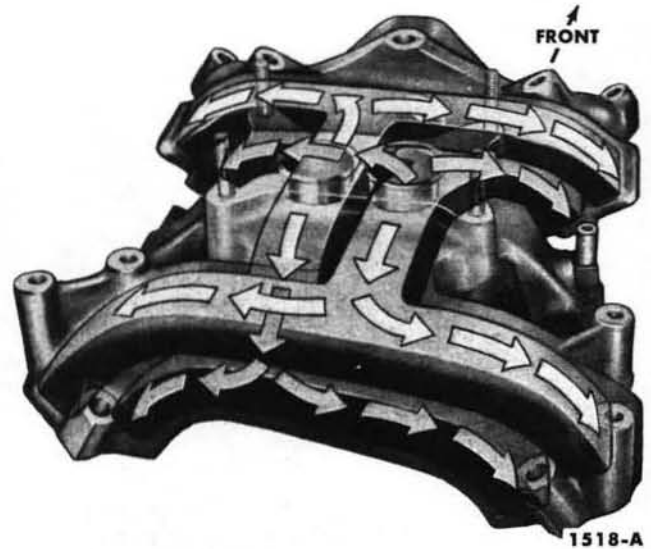
PayPal    American Express    Discover/Novus    MasterCard    VISA



**FIG. 5—Intake Manifold Exhaust Gas Passage—Typical**

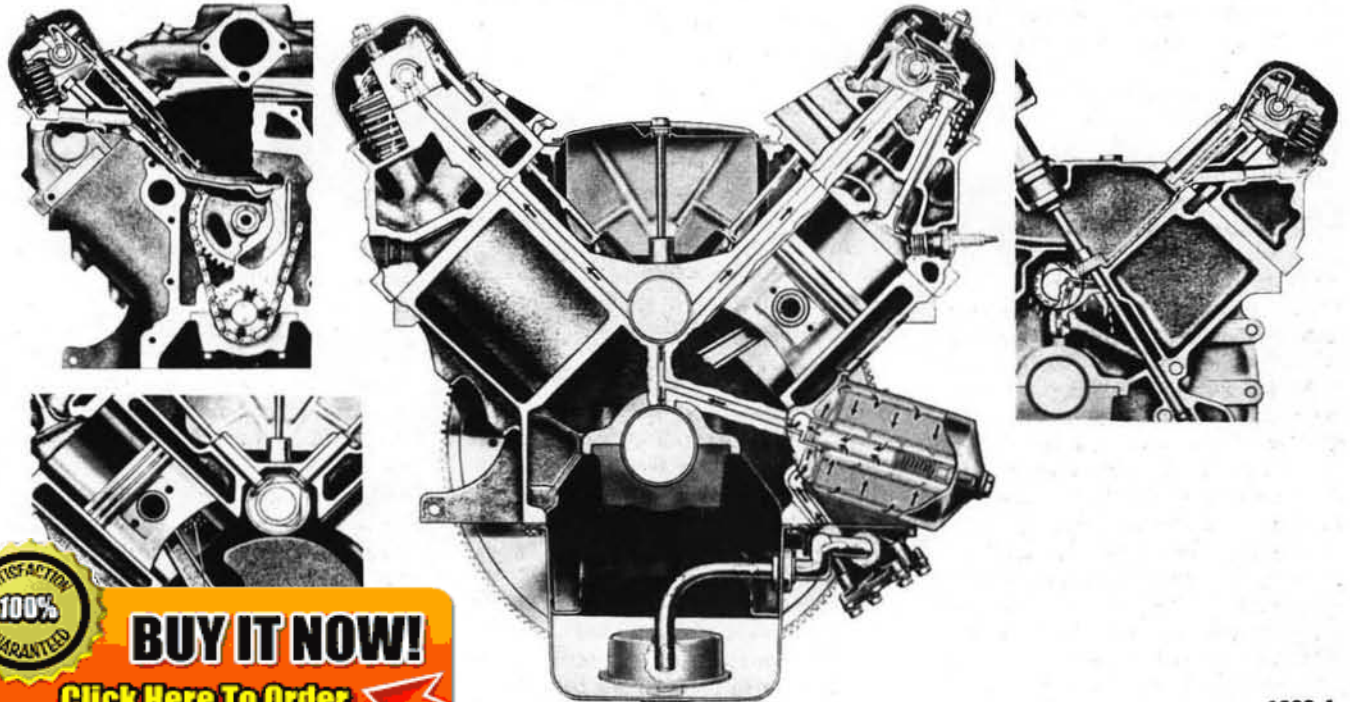
Oil relieved by the valve is directed back to the intake side of the pump. The engine is equipped with a full-flow-type filter which filters the entire output of the pump before the oil

enters the engine. A by-pass provides oil to the engine in case the filter element becomes clogged. The by-pass is located in the hollow center bolt of the filter and consists of a spring



**FIG. 6—Intake Manifold Fuel Passages—Typical**

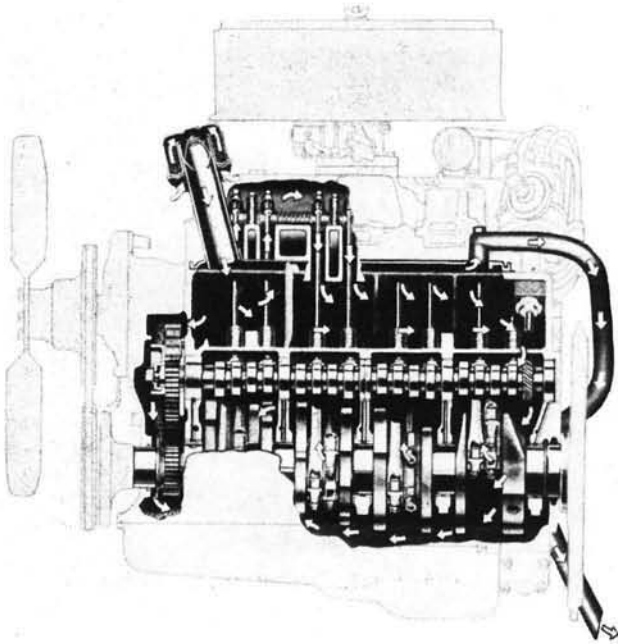
loaded valve. When the element is clean and oil will flow through it, the pressure difference between the inner and outer faces of the valve is not great enough to overcome the spring pressure behind the valve. Therefore, no oil flows through the by-pass. When the element is dirty and will not permit a sufficient flow of oil, the pressure acting on the inner face of



**100% SATISFACTION GUARANTEED**

**BUY IT NOW!**

**Click Here To Order**



1331-B

**FIG. 8—Crankcase Ventilation—Typical**

the valve drops. If the pressure difference between the valve faces is great enough to overcome spring pressure, the valve will open. Oil then by-passes the element, maintaining an emergency supply of oil to the engine.

The oil from the filter flows into the main oil gallery which supplies oil to all the camshaft and main bearings through a drilled passage in each main bearing web.

The right valve rocker arm shaft assembly receives oil from a drilled passage at the No. 3 camshaft bearing. The oil is directed into the No. 2 valve rocker arm support. The oil from the support flows into the rocker shaft. Metered holes in the shaft permit lubrication of each rocker arm shaft bore and the valve and ball joint ends of the rocker arms. The excess oil spirals down the rotating push rods. The left valve rocker arm shaft assembly is similarly lubricated from the No. 3 camshaft bearing via the No. 3 valve rocker arm support. The oil from each rocker arm drains into the push rod chamber through holes in the cylinder heads. In addition, each main shaft has an overflow

the oil pan through a hole at the rear of the block. This oil lubricates the distributor drive gears. The distributor shaft bushing is lubricated by oil from the No. 5 camshaft bearing.

The oil from the right valve rocker arm shaft assembly overflow tube lubricates the timing chain and sprockets or timing gears.

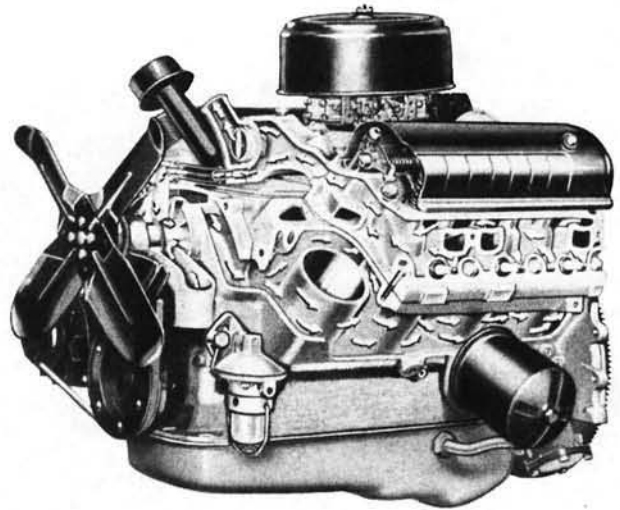
Oil slingers are provided to prevent leakage by directing oil away from the crankshaft front and rear oil seals.

Connecting rod bearings are lubricated by passages drilled from the crankshaft main journals to the connecting rod journals of the crankshaft. Cylinder walls are lubricated by oil sprayed from a hole drilled in each connecting rod.

### CRANKCASE VENTILATION

Clean air flows into the front section of the push rod chamber where there are few contaminating vapors (Fig. 8). Here, the incoming air has a chance to warm up before contacting contaminating vapors originating in the crankcase. Warm ventilating air minimizes the formation of crankcase sludge.

The ventilating air is directed by a tube, located on the push rod chamber, over, upward into the front of the valve rocker arm shaft chamber. The air is forced to the rear of



1332-C

**FIG. 9—Cooling System—Typical**

the chambers and down into the rear section of the push rod chamber and through an opening in the block into the crankcase. Air is also diverted from the front section of the push rod chambers through holes in the front wall of the cylinder block to ventilate the timing chain or gear chamber.

The air from the crankcase is directed into the crankcase ventilation tube by the forward motion of the truck which creates a partial vacuum at the crankcase ventilation tube outlet.

### COOLING SYSTEM

The coolant is drawn from the bottom of the radiator by the water pump which delivers the coolant to the cylinder block (Fig. 9).

The coolant travels through cored passages to cool the entire length of each cylinder wall. Upon reaching the rear of the cylinder block, the coolant is directed upward into the cylinder heads where it cools the combustion chambers, valves, and valve seats on its return to the front of the engine.

The coolant from each cylinder head flows through the water passages in the intake manifold, into the water outlet connection and past the water thermostat, if it is open, into the top of the radiator. If the thermostat is closed, a small portion of the coolant is returned to the water pump for recirculation. The entire system is pressurized to 7 psi by a pressure-type radiator cap.



**BUY IT NOW!**

**Click Here To Order**



## 2 ENGINE REMOVAL AND INSTALLATION

Engine removal and installation procedures are separated according to truck body styles.

### B-F-AND T-SERIES

A typical engine installation is shown in Fig. 10.

#### REMOVAL

1. Remove the hood. Drain the cooling system and the crankcase. Remove the air cleaner, the fan, spacer, and belt, and the radiator and shroud as an assembly.

On a truck with an air compressor, open the air reservoir drain cock. Disconnect the compressor air lines.

2. Disconnect the heater hoses at the engine and disconnect the generator wires. Remove the starter and dust seal. Disconnect the muffler inlet pipe(s) from the exhaust manifold(s), the primary wires at the ignition coil, and the choke control cable at the carburetor.

3. Remove the engine front support insulator bolts, accelerator return spring, water temperature and oil pressure sending unit wires at the sending units, and the engine ground strap. Disconnect the fuel line. Disconnect the vacuum brake booster hose at the intake manifold (if applicable).

On a truck with power steering, disconnect the power steering return line and the pump pressure line at the bracket on the frame left side member and drain the oil into a suitable container. Disconnect the power steering return line at the pump reservoir and the pressure line at the pump housing.

On an engine with an electric fuel pump, disconnect the oil pressure safety switch wires at the switch.

On a truck with a manual-shift transmission, disconnect the accelerator rod assembly at the accelerator assembly. Disconnect the throttle control cable at the carburetor and the cable clamp at the governor (4-barrel carburetor). Remove the release lever retracting spring (V-8 engines), the flywheel

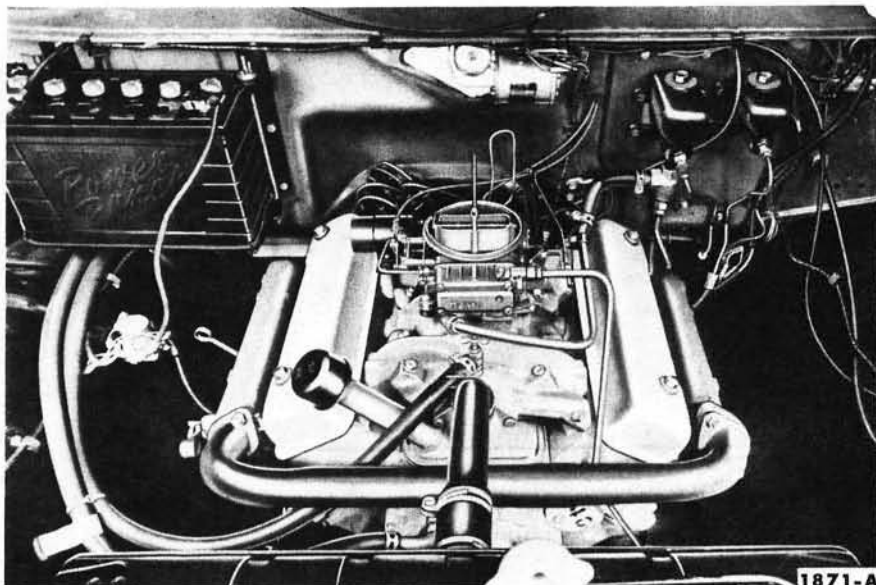


FIG. 10—MD V-8 Engine Installation—F-Series Truck

assembly. Disconnect the oil cooler inlet and outlet hoses.

4. Support the transmission and attach the engine lifting hooks (tool T53L-6000-B) and sling (tool T53L-300-A). Raise the engine slightly, then carefully pull the engine from the transmission. Lift the engine out of the engine compartment. Install the engine on a work stand (Fig. 11 or 12). **On a 302 or 332 engine, lower the engine on blocks and remove the right exhaust manifold and gasket. Remove the mount from the work stand and install it on the engine, then install the engine on the work stand.**

#### INSTALLATION

1. Attach the engine lifting hooks and sling, then remove the engine from the work stand. **On a 302 or 332 engine, disconnect the mount from the work stand, then lower the engine on blocks. Remove the mount, then install the right exhaust manifold and gasket.** Place a new gasket over the muffler inlet pipe studs on the exhaust manifold(s).

2. Lower the engine carefully into the engine compartment. Make sure the exhaust manifold(s) are properly aligned with the muffler inlet pipe(s) and the dowels in the block engage the holes in the flywheel or converter housing.

On a truck with an automatic transmission, start the converter pilot into the crankshaft. Install the converter

housing retaining bolts, the converter to flywheel nuts, and the converter housing front and lower covers. Connect the throttle rod at the engine mounted accelerator shaft and bracket assembly. Connect the accelerator rod assembly to the accelerator assembly, and install the accelerator return spring. Connect the accelerator pedal. Connect the oil cooler inlet and outlet hoses.

On a truck with a manual-shift transmission, start the transmission main drive gear into the clutch disc. It may be necessary to adjust the position of the transmission in relation to the engine if the input shaft will not enter the clutch disc. **If the engine "hangs up" after the shaft enters, turn the crankshaft slowly (transmission in gear) until the shaft splines mesh with the clutch disc splines.** Install the flywheel housing bolts, the flywheel housing inspection cover, the clutch lever retracting spring (all HD V-8 engines), the throttle control cable, the throttle control cable clamp (all HD V-8 engines), and the accelerator spring.

3. Remove the support from the transmission. Install the engine front support insulator bolts and tighten the bolts to specifications. Connect the muffler inlet pipes and tighten the nuts to specifications. Install the starter seal and starter.

4. Connect the coil primary wires, the choke control cable, the generator



**BUY IT NOW!**

**Click Here To Order**



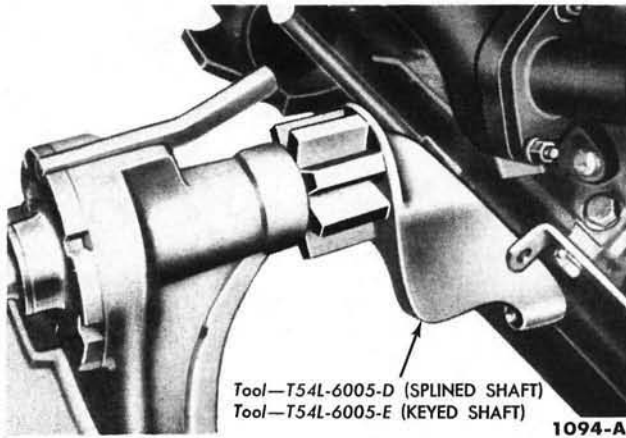


FIG. 11—Engine Mount—292 Engine

wires, the engine ground strap, the oil pressure and water temperature sending unit wires, and the fuel line.

On an engine with an electric fuel pump, connect the oil pressure safety switch wires.

5. Connect the heater hoses. Install the radiator and shroud assembly, install the drive belts, spacer, and fan.

On a truck with an air compressor, connect the reservoir to compressor line, and close the reservoir drain cock.

On a truck with power steering, connect the power steering return line to the pump reservoir and the pressure line at the pump housing. Connect the return line to the bracket on the frame left side member. Fill the power steering pump reservoir.

6. Fill the crankcase with the proper grade and quantity of engine oil and fill and bleed the cooling system. Install the hood. Run the engine at fast idle and check all gaskets and hose connections for leaks. Install the air cleaner.

On a truck with an automatic transmission, adjust the throttle linkage.

### C-SERIES

A typical engine installation is shown in Fig. 13.

### REMOVAL

1. Release the cab lock and tilt the cab forward. Drain the cooling system and the crankcase.

2. Remove the clamps holding the

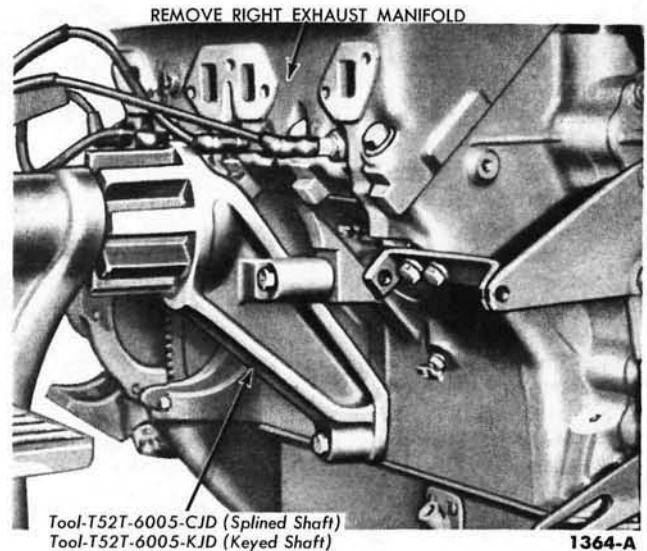


FIG. 12—Engine Mount—302 or 332 Engine

On a truck with an air compressor, open the air reservoir drain cock. Disconnect the air line at the front of the engine and place the line against the frame side rail.

4. Disconnect the fuel line, then install a cap on the fuel line.

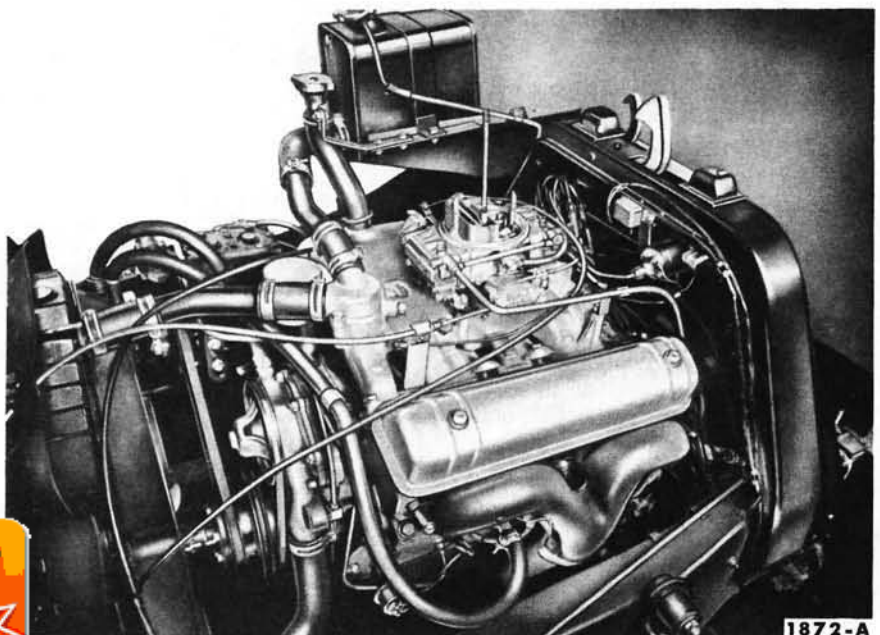
5. Disconnect the oil pressure and water temperature sending unit wires at the sending units. Disconnect the throttle control, choke control, and the accelerator cables at the carburetor, and the vacuum brake hose (if so equipped).

6. Remove the clutch release lever retracting spring (all HD V-8 engines).

7. Disconnect the primary wires at the ignition coil, and disconnect the generator wires.

On an engine with an electric fuel pump, disconnect the oil pressure safety switch wires at the switch.

8. Remove the starter. Disconnect the radiator supply tank hose at the tank. Remove the oil filler pipe assembly clamp at the coolant supply tank bracket. Disconnect the muffler inlet pipes at the exhaust manifolds.



100% SATISFACTION GUARANTEED

**BUY IT NOW!**

Click Here To Order

PayPal American Express Discover/Novus MasterCard VISA

9. Support the transmission and remove the flywheel housing inspection cover and the flywheel housing to engine retaining bolts.

10. Remove the engine front support insulator bolts. Attach the engine lifting hooks (tool T53L-6000-B) and sling (tool T53L-300-A). Remove the engine and lower the engine on blocks and remove the right exhaust manifold and gasket. Remove the mount from the work stand and install it on the engine, then install the engine on the work stand (Fig. 11 or 12).

#### INSTALLATION

1. Place a new gasket over the exhaust manifold studs. Attach the engine lifting hooks and sling. Disconnect the mount from the work stand and lower the engine on blocks, then remove the mount from the engine and install the right exhaust manifold and gasket.

2. Lower the engine carefully into the engine compartment. Make sure the exhaust manifolds are properly aligned with the muffler inlet pipes and the dowels in the block engage the holes in the flywheel housing.

3. Install the flywheel housing to engine retaining bolts and install the engine front support insulator bolts. Remove the transmission support.

4. Install the flywheel housing inspection cover and the starter. Connect the muffler inlet pipes.

5. Connect the radiator supply tank hose, the coil and primary wires, and the vacuum brake hose (if so equipped). Connect the generator wires.

On an engine with an electric fuel pump, connect the oil pressure safety switch wires.

6. Install and adjust the drive belts. Install the oil filler pipe assembly clamp to the radiator supply tank bracket.

7. Connect the accelerator cable, choke control cable, the throttle control cable, and the oil pressure and the temperature sending unit wires.

8. Remove the fuel line plug and connect the fuel line. Install the clutch release lever retracting spring (all HD V-8 engines).

Install the radiator and shroud as

line, and close the reservoir drain cock.

11. Fill the crankcase with the proper grade and quantity of engine oil and fill the cooling system. Run the engine at fast idle and check all gaskets and hose connections for leaks. Install the air cleaner.

#### P-SERIES

The engine and transmission are removed as an assembly.

#### REMOVAL

1. Drain the cooling system and the crankcase. Remove the driver's seat assembly, the master cylinder inspection cover, and the steering column cover plates. Disconnect the accelerator pedal at the accelerator assembly, and the wires from the headlight beam selector switch.

2. Remove the left wheel house panel and the center floor plate. Remove the screws fastening the right side of the engine rear cover panel to the right wheel house panel. Remove the bolts and nuts retaining the rear flange of the engine rear cover to the removable frame cross member and the center floor plate front bracket. Wedge the right and left frame gussets open so the rear flange of the engine rear cover plate will clear the slots. Remove the removable cross member.

3. Remove the air cleaner. Disconnect the battery ground cable, the water temperature and oil pressure sending unit wires at the sending units, coil primary wires, relay to starter cable at the starter, starter to frame cable at the starter, and the radiator upper and lower hoses.

4. Remove the engine front support insulator bolts. Disconnect the speedometer cable at the drive gear, the generator wires, and the brake vacuum hose at the intake manifold line. Disconnect the flexible fuel line at the fuel tank line and install a cap on the tank line. Disconnect the choke control cable at the carburetor. Remove the right exhaust manifold to muffler inlet pipe retaining nuts.

5. Remove the carburetor air cleaner stud and the engine rear support retaining capscrews. Remove the hand brake cable bracket and cable.

6. Disconnect the universal joint to transmission output shaft flange. Disconnect the manual control rods at the transmission lever (automatic transmission). Disconnect the clutch hydraulic slave cylinder hose (manual-shift transmission).

7. Using a floor crane, and engine

lifting hooks (tool T53L-6000-B) and sling (tool T53L-300-A), remove the engine and transmission as an assembly.

#### INSTALLATION

1. Place a new gasket over the exhaust manifold studs. Using a floor crane, and the engine lifting hooks and sling, position the engine and transmission (as an assembly) in the chassis. Install the engine rear support capscrews, then install safety wire on the capscrews. Install the engine front support to frame cross member bolts and nuts, then tighten the nuts to specifications.

2. Install the hand brake cable. Connect the generator wires and the brake vacuum hose. Remove the cap from the fuel tank line and connect the flexible fuel line. Connect the choke control cable, the speedometer cable, and the right exhaust manifold to the muffler inlet pipe. Tighten the muffler inlet pipe nuts to 23-28 foot-pounds torque.

3. Connect the radiator upper and lower hoses, the starter to frame cable, the relay to starter cable, the coil primary wires, the water temperature and oil pressure sending unit wires, and the battery cable.

4. Install the frame cross member and connect the universal joint to transmission output shaft flange. Connect the clutch hydraulic slave cylinder hose and bleed the cylinder (manual-shift transmission). Position the engine cover assembly and the engine cover rear panel assembly and install the flange of the engine cover rear panel between the frame gussets and frame removable cross member. Remove the wedges.

5. Install the right side of the engine rear cover panel to the right wheel house panels.

6. Connect the headlight beam selector switch wires and the accelerator pedal.

7. Install the engine left cover to wheel house panel, the steering column cover plates, and the master cylinder inspection cover. Install the driver's seat assembly.

8. Fill the crankcase with the proper grade and quantity of engine oil. Fill and bleed the cooling system.

9. Operate the engine at fast idle and check all gaskets and hose connections for leaks. Install the air cleaner anchor screw and the air cleaner.

10. On a truck with an automatic transmission, adjust the throttle linkage.

**100% SATISFACTION GUARANTEED**

**BUY IT NOW!**

**Click Here To Order**

PayPal   American Express   Discover   MasterCard   VISA

### 3 ENGINE SUPPORTS

#### ENGINE FRONT SUPPORT

The engine front support is shown in Figs. 14 and 15.

##### REMOVAL

Remove the nuts, washers, bolts, and lower insulator(s) from the front support. Raise the front of the engine, then remove the upper insulator(s).

##### INSTALLATION

Place the upper insulator(s) in position on the frame bracket, then lower the engine. Install the lower insulator(s), bolts, washers, and nuts. Tighten the bolts to specifications.

#### ENGINE REAR SUPPORT

The engine rear support is shown in Fig. 16.

##### REMOVAL

Remove the nut, bolt, lower insulator, and spacer from each rear support. Raise the rear of the engine, then remove the insulators.

##### INSTALLATION

Place the upper insulator in position on each side of the engine, then lower the engine. Install the spacer, the lower insulator, bolt and nut on each side of the engine. Tighten the bolts to specifications.

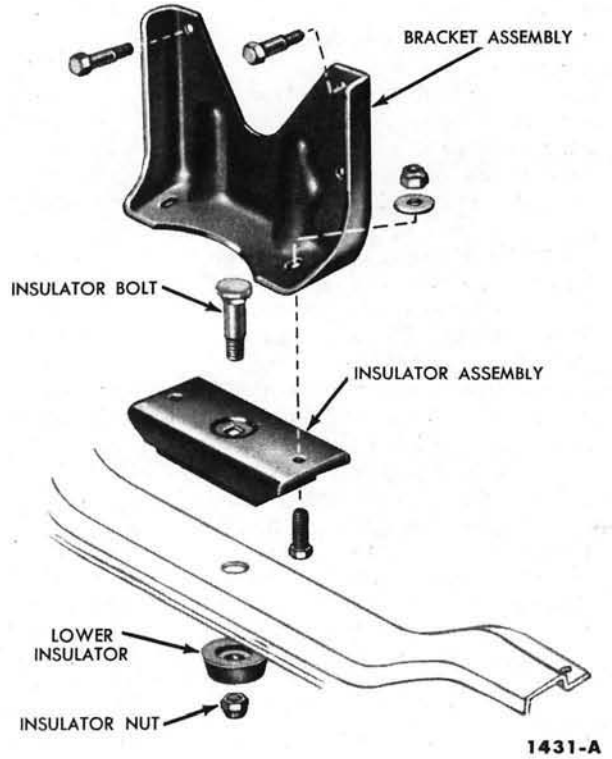


FIG. 15—Engine Front Support—302 or 332 Engine

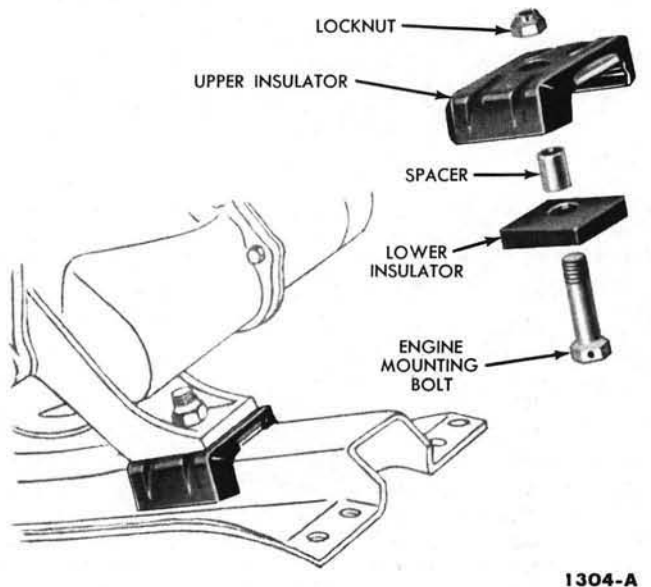


FIG. 16—Engine Rear Support



**BUY IT NOW!**

**Click Here To Order**



## 4 MANIFOLDS, CYLINDER HEADS, AND VALVES

### INTAKE MANIFOLD

The intake manifold assembly is shown in Fig. 17.

#### REMOVAL

1. Drain the radiator. Remove the air cleaner. Disconnect the distributor vacuum line at the distributor (MD V-8), the governor vacuum lines at the controlling unit (HD V-8), the fuel line, the vacuum brake line (if applicable) at the intake manifold, and the radiator upper hose at the water outlet housing. Disconnect the water by-pass tube. Disconnect the radiator supply tank hose at the tank (C-series trucks). Disconnect the engine temperature sending unit wire if the sending unit is installed in the intake manifold.

2. Disconnect the primary wire at the coil. Disconnect the accelerator cable, throttle control cable, and the choke control cable at the carburetor. Disconnect the heater inlet hose and the heater vacuum control line (if so equipped).

3. Remove the intake manifold retaining screws and clamps, then remove the intake manifold and carburetor as an assembly.

#### INSTALLATION

1. Using new gaskets, position the intake manifold on the engine. Position the manifold clamps, install the manifold retaining bolts and nuts, then tighten the bolts to 23-28 foot-pounds torque, working from the center to the ends.

2. Connect the heater inlet hose and the heater vacuum control line (if applicable). Connect the choke control cable, the throttle control cable, the accelerator cable, and the coil primary wire. Connect the engine temperature sending unit wire. Connect the water by-pass tube, the radiator upper hose, and the vacuum brake line (if applicable). Connect the fuel line, the governor vacuum lines (HD V-8), and the distributor vacuum line (MD V-8). Connect the radiator supply tank hose (C-series trucks). Fill and bleed the cooling system and install the air cleaner.

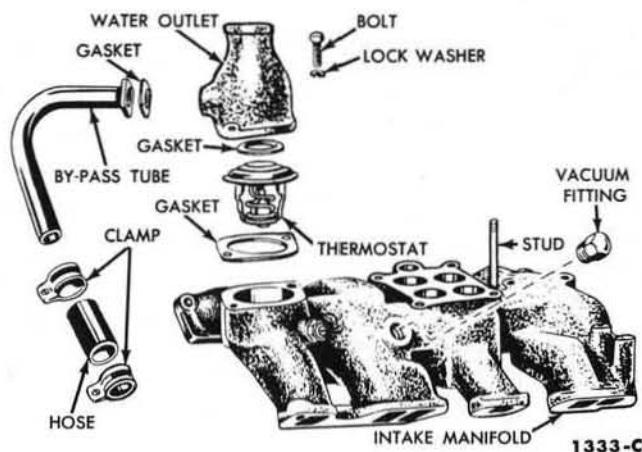


FIG. 17—Intake Manifold Assembly—Typical

The 292 HD V-8 engine has a ram's horn manifold when it is installed in a C-series truck. Follow the procedure for a 302 or 332 engine.

#### Removal

1. Disconnect the crossover pipe from both manifolds. Remove the exhaust gas control valve (if applicable). Disconnect the muffler inlet pipe from the manifold. Remove the manifold bolts.

2. Remove the spark plug heat shields, then remove the manifolds.

#### Installation

1. Lightly coat the mating surfaces of the manifold with graphite grease. Apply water resistant sealer to the retaining bolts (292 HD V-8 engine). Install the manifold rear bolt, then position the slotted end of the manifold on the bolt.

2. Install the spark plug heat shields. Install the washers and the remaining retaining bolts. Tighten the bolts to 23-28 foot-pounds torque working from the center to the ends. Install the exhaust gas control valve on the right manifold with a gasket on both sides (if applicable). Install one crossover pipe gasket on the left manifold. Place the crossover pipe on the manifold studs, and install the retaining nuts. Tighten the nuts to 23-28 foot-pounds torque. Install the muffler inlet pipe using a new gasket.

#### Crossover Pipe Replacement — Single Exhaust System

1. Remove the nuts and lockwashers retaining each end of the pipe to the manifolds. Remove the crossover

pipe, exhaust gas control valve and gaskets.

2. Position the exhaust gas control valve on the right manifold with a new gasket on each side. Position a new gasket on the left manifold, then install the crossover pipe. Tighten the nuts to 23-28 foot-pounds torque.

**Exhaust Gas Control Valve Replacement—292 MD V-8 Engine.** Remove the exhaust manifold crossover pipe, then remove the valve from the right exhaust manifold. Clean the exhaust manifold and crossover pipe flanges. Place a new gasket on both sides of the valve and position the valve on the right exhaust manifold. Install the crossover pipe. Tighten the nuts to 23-28 foot-pounds torque.

#### 302 AND 332 HD V-8 ENGINES

The following procedures apply to either a right or left manifold.

**Removal.** Disconnect the muffler inlet pipe from the manifold. Remove the exhaust manifold bolts, spark plug heat shields, and the exhaust manifold and gasket.

**Installation.** Lightly coat the mating surfaces of the exhaust manifold with graphite grease and apply water resistant sealer to the retaining bolts. Position the exhaust manifold and gasket against the cylinder head. Install the end bolts and tighten them finger tight. Install the spark plug heat shields and the remaining bolt. Tighten the bolts to 23-28 foot-pounds torque beginning at the center and working toward either end. Connect

**100% SATISFACTION GUARANTEED**

**BUY IT NOW!**

**Click Here To Order**

PayPal    American Express    Discover    MasterCard    VISA

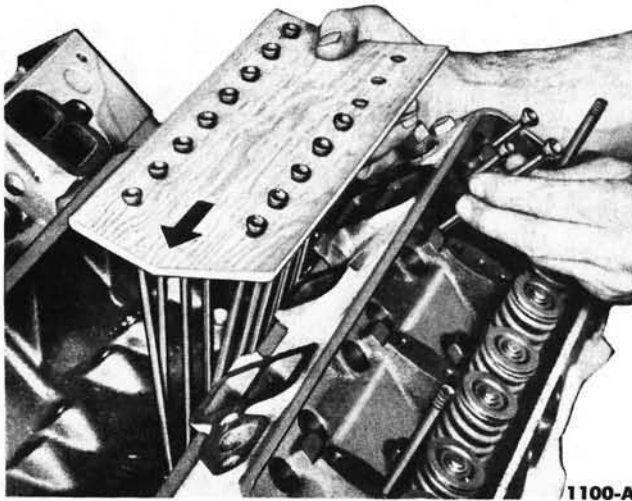


FIG. 18—Valve Push Rod Removal

the muffler inlet pipe to the exhaust manifold flange and tighten the nuts to 23-28 foot-pounds torque.

### CYLINDER HEAD REMOVAL

1. Drain the cooling system. Remove the air cleaner. Clean the outside of the valve rocker arm covers and remove the covers. Remove the exhaust manifolds and the spark plugs. Remove the intake manifold and carburetor as an assembly. Clean the outside of the valve push rod cover and remove the cover. Remove the air compressor (if applicable).

On the right cylinder head, remove the ignition harness bracket. Remove the generator bracket rear bolt (292 engine).

On the left cylinder head, disconnect the temperature sending unit wire from the sending unit (292 engine). Disconnect the engine ground strap.

2. Release the spring tension on the valve rocker arms by loosening the adjusting screws, then remove the valve rocker arm shaft assembly and oil baffle plates. The oil baffle plates are used only on a 302 or 332 engine. **Remove the exhaust valve caps from all HD V-8 engines. Identify the caps for proper installation.**

3. Remove and identify the valve push rods so they can be replaced in the correct positions (Fig. 18).

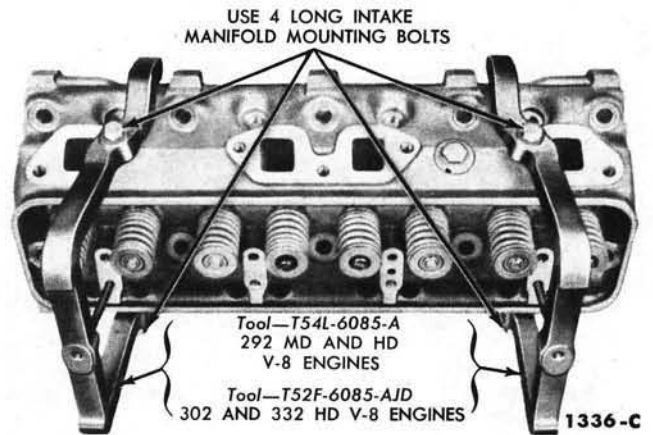


FIG. 19—Cylinder Head Holding Fixtures

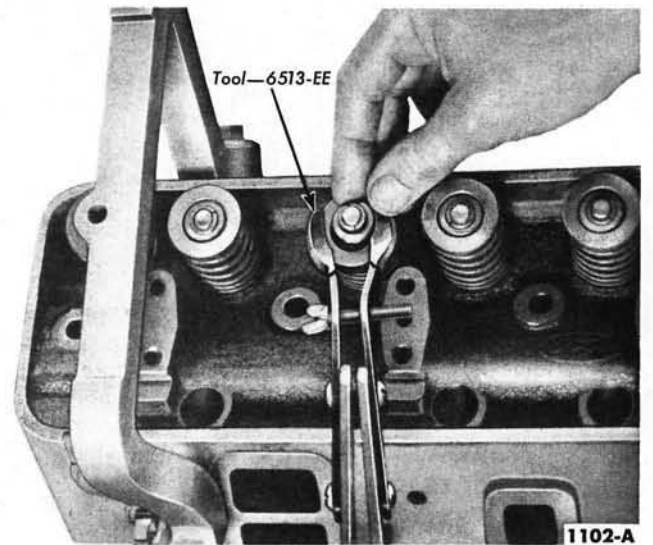


FIG. 20—Valve Spring Retainer Locks—Removal or Installation

### VALVE ROCKER ARM SHAFT DISASSEMBLY

1. Remove the cotter pins at each end of the valve rocker arm shaft, then remove the flat washers and spring washers. Slide the rocker arms, springs, and brackets off the shaft.

2. If it is necessary to remove the plugs from each end of the shaft, drill or pierce one plug, then insert a steel rod through the plug and knock out the plug on the opposite end. Working from the open end, knock out the remaining plug.

### CYLINDER HEAD DISASSEMBLY

1. Remove the spark plugs. Clean the combustion chambers before removing the valves. Compress the valve springs (Fig. 20), then remove the valve spring retainer locks, and release the

2. Remove the sleeve, spring retainer, spring, and valve. Discard the valve stem seals. Identify all valve parts.

### VALVE ROCKER ARM SHAFT ASSEMBLY

1. Oil all moving parts with engine oil.

2. If the plugs were removed from the end of the shaft, use a blunt tool or large diameter pin punch and install a plug, cup side out, in each end of the valve rocker arm shaft.

3. Install a flat washer, spring washer, another flat washer and a cotter pin on one end of the shaft.

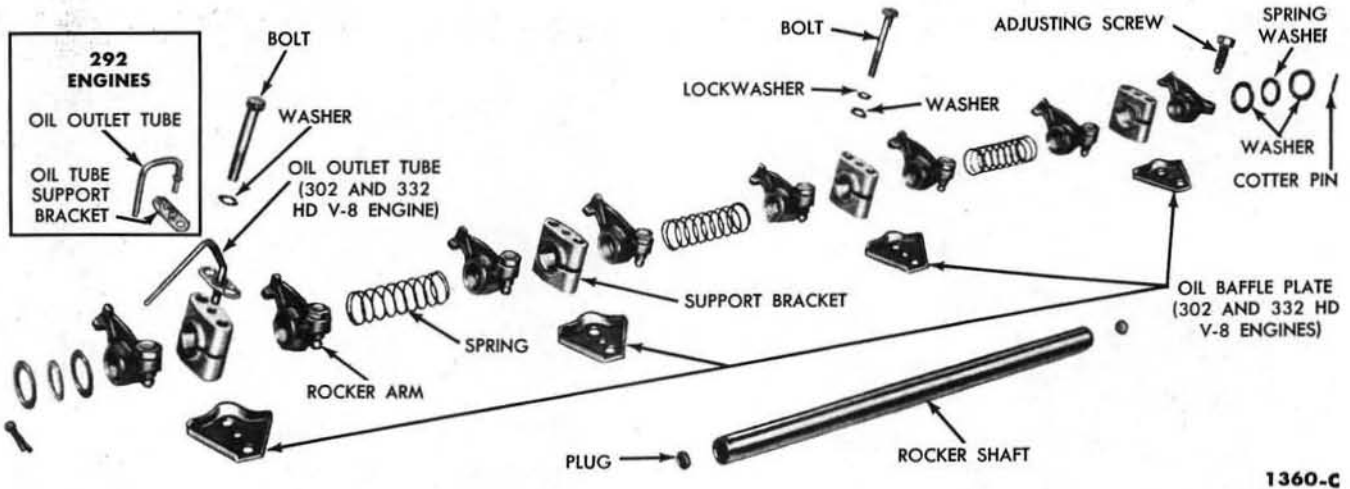
4. Install the rocker arms, support brackets, and springs in the order shown in Fig. 21. Complete the assembly by installing the remaining two flat washers with the spring washer between them, then install the cotter pin.

100% GUARANTEED

**BUY IT NOW!**

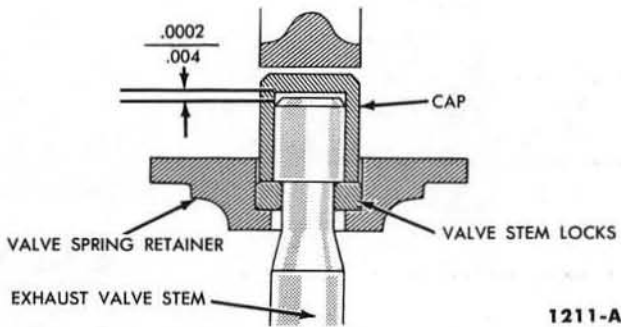
Click Here To Order

PayPal    American Express    Discover    MasterCard    VISA



1360-C

FIG. 21—Valve Rocker Arm Shaft Assembly



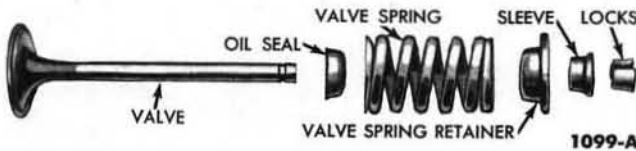
1211-A

FIG. 22—Valve Clearance—Free Turning Valve



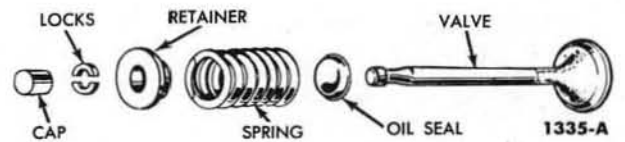
1221-A

FIG. 23—Measuring Valve To Cap Clearance—Free Turning Valve



1099-A

FIG. 24—Rotating Type Valve Assembly



1335-A

FIG. 25—Free-Turning-Type Valve Assembly



1018-A

**CYLINDER HEAD ASSEMBLY**

1. On the exhaust valves of all HD V-8 engines, measure the clearance between the end of the valve stem and the inside of the cap (Figs. 22 and 23). The correct clearance is 0.0002-0.004-inch. The proper clearance is necessary so that the cap can carry the valve spring pressure permitting the valve to rotate. If the clearance is greater than 0.004 inch, reduce the clearance by lapping the open end of the cap on a smooth surface.

2. Install each valve in the guide from which it was removed or to which it was fitted (Fig. 24 or 25). Install a new stem seal, cup side down on the valve.

3. Install the valve spring, retainer and the sleeve (rotating-type valve).

4. Compress the spring and install the retainer locks (Fig. 20).



**BUY IT NOW!**

Click Here To Order



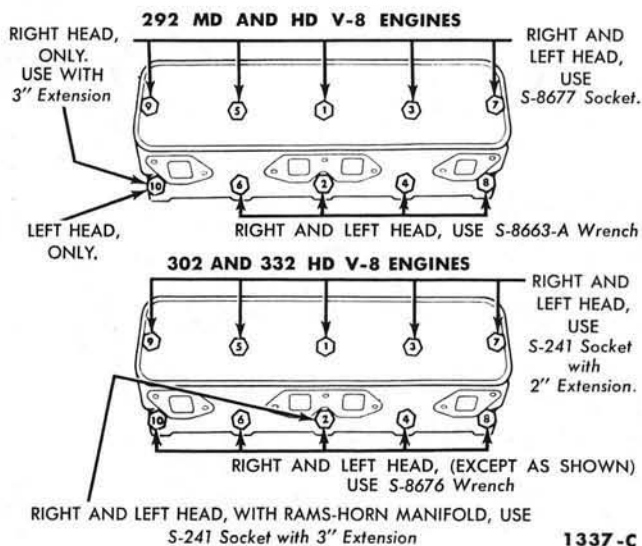


FIG. 27—Cylinder Head Bolt Tightening Sequence

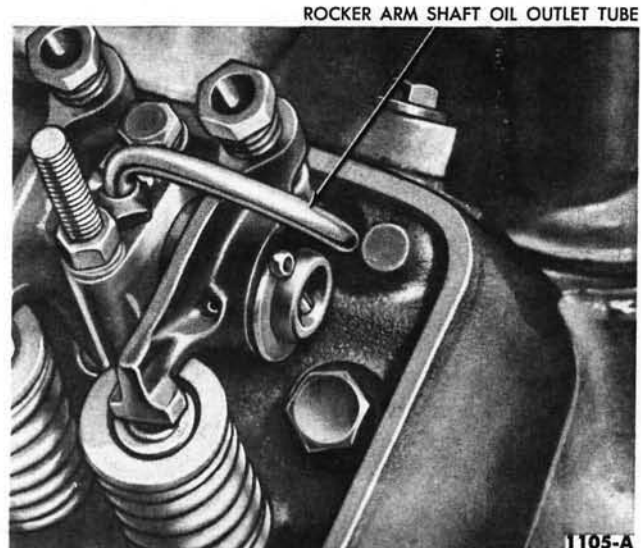


FIG. 28—Valve Rocker Arm Shaft Oil Drain Tube Position

TABLE 2—Cylinder Head Bolt Tightening Procedure

Engine	1st	2nd	3rd
All 292	55 ft-lbs	65 ft-lbs	75 ft-lbs
302 and 332 HD V-8	90 ft-lbs	100 ft-lbs	110 ft-lbs

5. Measure the assembled height of the valve springs from the surface of the cylinder head spring pad to the underside of the spring retainer with dividers (Fig. 26). Check the dividers against a scale. If the assembled height is greater than  $1\frac{13}{16}$  inches, install the necessary 0.030-inch thick spacer(s) between the cylinder head spring pad and the valve spring to bring the assembled height to the recommended dimension of  $1\frac{25}{32}$ – $1\frac{13}{16}$  inches. Do not install spacers unless necessary. Use of spacers in excess of recommendations will result in overstressing the valve springs which will lead to excessive load loss and spring breakage.

### CYLINDER HEAD INSTALLATION

1. Remove deposits from the head

as follows: 1. Remove the head from the engine. 2. Clean the head with a wire brush. 3. Wash the head with a degreaser. 4. Rinse the head with water. 5. Dry the head. 6. Inspect the head for damage. 7. Replace the head gasket. 8. Install the head on the engine. 9. Tighten the bolts. 10. Check the oil level. 11. Start the engine. 12. Check for leaks. 13. Adjust the valve lash. 14. Check the timing. 15. Check the oil pressure. 16. Check the water pump. 17. Check the alternator. 18. Check the generator. 19. Check the battery. 20. Check the lights. 21. Check the horn. 22. Check the wipers. 23. Check the brakes. 24. Check the steering. 25. Check the suspension. 26. Check the tires. 27. Check the wheels. 28. Check the axle. 29. Check the frame. 30. Check the chassis. 31. Check the engine. 32. Check the transmission. 33. Check the drivetrain. 34. Check the exhaust. 35. Check the intake. 36. Check the cooling system. 37. Check the fuel system. 38. Check the ignition system. 39. Check the electrical system. 40. Check the safety system. 41. Check the interior. 42. Check the exterior. 43. Check the paint. 44. Check the body. 45. Check the trim. 46. Check the upholstery. 47. Check the windows. 48. Check the doors. 49. Check the trunk. 50. Check the hood. 51. Check the bumper. 52. Check the fenders. 53. Check the mirrors. 54. Check the wheels. 55. Check the tires. 56. Check the brakes. 57. Check the steering. 58. Check the suspension. 59. Check the chassis. 60. Check the frame. 61. Check the engine. 62. Check the transmission. 63. Check the drivetrain. 64. Check the exhaust. 65. Check the intake. 66. Check the cooling system. 67. Check the fuel system. 68. Check the ignition system. 69. Check the electrical system. 70. Check the safety system. 71. Check the interior. 72. Check the exterior. 73. Check the paint. 74. Check the body. 75. Check the trim. 76. Check the upholstery. 77. Check the windows. 78. Check the doors. 79. Check the trunk. 80. Check the hood. 81. Check the bumper. 82. Check the fenders. 83. Check the mirrors. 84. Check the wheels. 85. Check the tires. 86. Check the brakes. 87. Check the steering. 88. Check the suspension. 89. Check the chassis. 90. Check the frame. 91. Check the engine. 92. Check the transmission. 93. Check the drivetrain. 94. Check the exhaust. 95. Check the intake. 96. Check the cooling system. 97. Check the fuel system. 98. Check the ignition system. 99. Check the electrical system. 100. Check the safety system.

2. Place the cylinder head on the engine, then remove the holding fixtures. Coat the cylinder head bolt threads with water resistant sealer and install the bolts. The cylinder head bolt tightening procedure is performed in three progressive steps. Tighten the bolts to the specifications listed in Table 2 following the sequence shown in Fig. 27. Each step in the tightening procedure is performed with the engine cold. After the cylinder head bolts have been tightened to specifications, the bolts should not be disturbed.

3. Install the valve push rods in their proper sequence, making sure the lower ends of the rods are positioned in the tappet socket.

4. Position the oil baffle plates (used only on a 302 or 332 engine) on the head, then place the valve rocker arm shaft assemblies on the support retaining screws. Install the oil drain tube on the same end from which it was removed.

The support end of the tube must enter the locating hole in the valve rocker arm shaft to properly position the shaft. Position the oil drain tube on the right valve rocker arm shaft assembly so the oil will drain in the front (No. 1 exhaust) push rod opening (Fig. 28). Position the oil drain tube on the left valve rocker arm shaft assembly so the oil will drain in the end (No. 8 exhaust) push rod opening. On a 302 or 332 engine, be sure the valve rocker arm shaft supports are installed so that the large O.D. end of the center hole in the support is to the top. There is a difference in height when the supports are installed upside down.

5. Tighten the bracket retaining bolts to specifications. Perform a preliminary (cold) valve lash adjustment. Install the valve push rod chamber gasket and cover.

On the right cylinder head, install the ignition harness bracket. Install the generator bracket rear bolt (292 engine).

100% SATISFACTION GUARANTEED

**BUY IT NOW!**

Click Here To Order

PayPal American Express Discover Novus MasterCard VISA

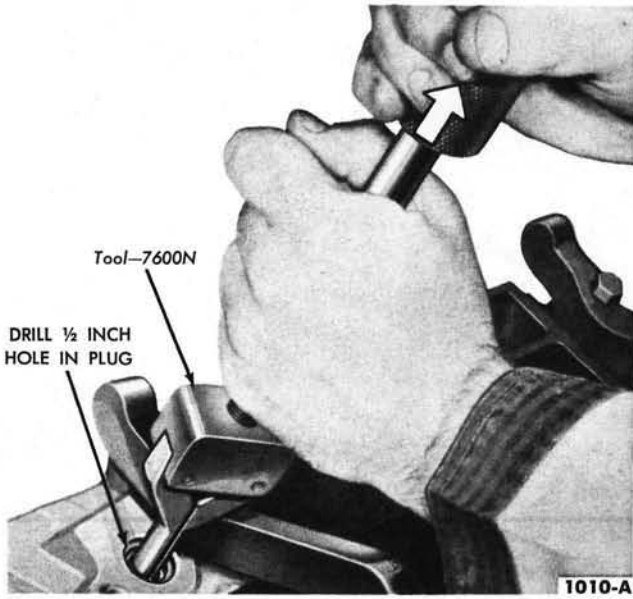


FIG. 29—Water Outlet Plug Removal

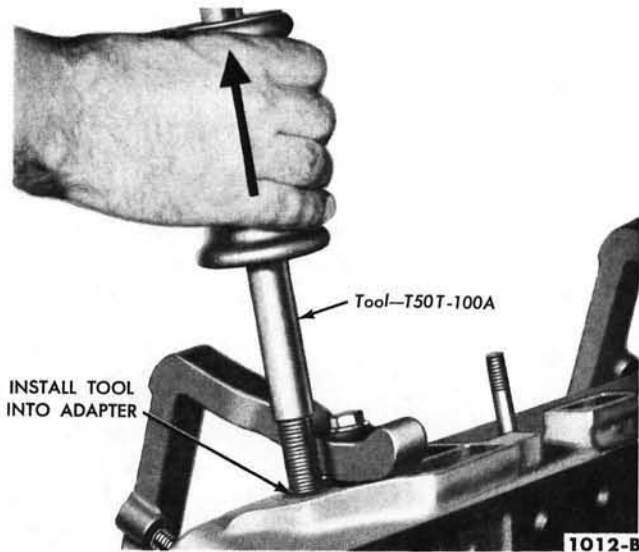


FIG. 31—Sending Unit Adapter Removal

On the left head, connect the temperature sending unit wire (292 engine). Connect the engine ground strap.

6. Install the intake manifold and carburetor as an assembly. Install the spark plugs, then install the exhaust manifold and gaskets (302 or 332

8. Coat one side of the valve rocker arm cover gaskets with oil resistant sealer, and lay the cemented side of the gasket in place in the covers. Install the valve rocker arm covers, making sure that the gasket seats evenly all around the head. Install the rubber seals on the studs making sure they are centered in the cover openings. Tighten the retaining nuts to -2.5 foot-pounds torque.

**WATER OUTLET CONNECTION**

The cylinder head assemblies are interchangeable from one cylinder head to the other.

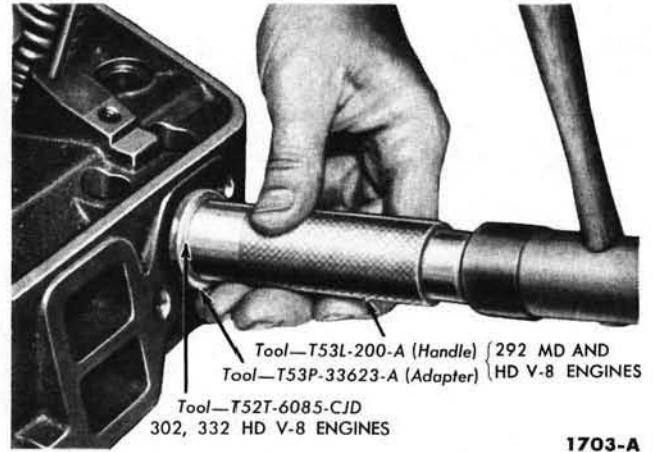


FIG. 30—Water Outlet Plug Installation

To interchange the heads on a 292 engine, it is necessary to install a plug in the water outlet at the rear of the right cylinder head and install a water temperature sending unit adapter in the water opening at the rear of the left cylinder head.

To interchange the heads on a 302 or 332 engine, it is necessary to remove the water outlet core plug from the rear of the head, and install a new plug in the water inlet opening at the front end, thereby reversing the water inlet connection, and permitting the head to be installed on the opposite bank.

The temperature sending unit is installed in a threaded boss located in the intake manifold of the 302 or 332 engine.

Replacement cylinder heads do not have either the plug or adapter installed; therefore, they can be readily adapted for either right or left installations.

**Water Outlet Plug.** To remove the water outlet plug, drill a 1/2-inch hole in the center of the plug and remove it as shown in Fig. 29.

To install the plug, clean the plug recess thoroughly, and coat the flange of the plug with water resistant sealer and install it with the flange facing out. Drive the plug in until the flange is flush or slightly below the casting surface (Fig. 30).

**Sending Unit Adapter — 292 Engine.** To remove the adapter, thread the impact hammer handle into the adapter, then tighten the lock nut against the adapter (Fig. 31). Remove the adapter by using the slide hammer.

**100% SATISFACTION GUARANTEED**

**BUY IT NOW!**

**Click Here To Order**

PayPal American Express Discover Novus MasterCard VISA

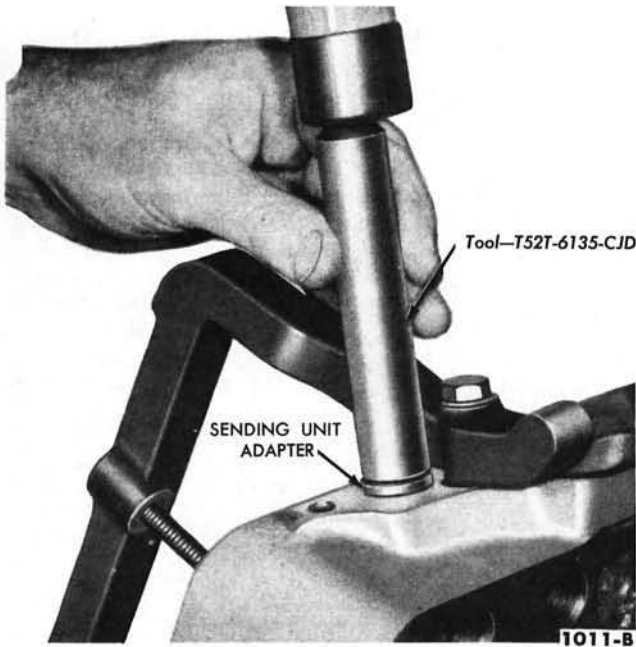
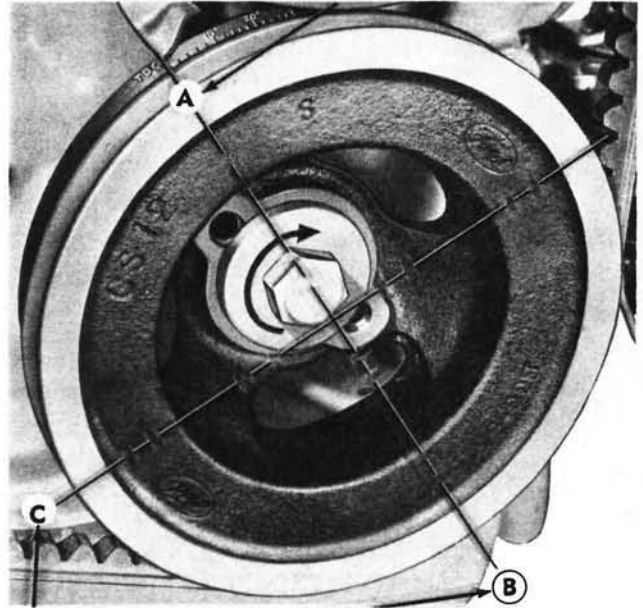


FIG. 32—Sending Unit Adapter Installation

STEP 1 —SET NO. 1 PISTON ON T.D.C. AT END OF COMPRESSION STROKE—ADJUST NO. 1, 4, 5 EXHAUST & NO. 1, 2, 7 INTAKE



STEP 2 —ADJUST NO. 6 & 8 EXHAUST & NO. 4 & 5 INTAKE  
STEP 3 —ADJUST NO. 2, 3, 7 EXHAUST & NO. 3, 6, 8 INTAKE

FIG. 33—Preliminary Valve Lash Adjustment—Typical

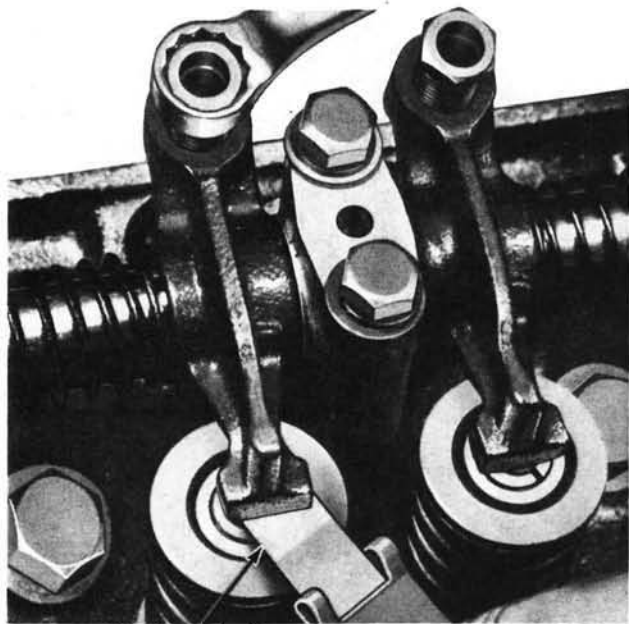


FIG. 34—Valve Lash Adjustment—Typical

contact with the seats long enough to cool properly. If the lash is excessive, it will cause the valve to open too late and close too early causing valve bounce. In addition, damage to the camshaft lobe is likely because the tappet foot will not follow the pattern of the camshaft lobe causing a shock contact between these two parts.

If the cylinder head or the valve rocker arm shaft assembly has been removed and installed, it will be necessary to make a preliminary (cold) valve lash adjustment before starting the engine. If the adjustment is made for an engine tune-up, follow the final adjustment procedure.

The cylinders are numbered from front to rear-right bank, 1-2-3-4; left bank, 5-6-7-8. The valves are arranged from front to rear on both banks, E-I-I-E-E-I-I-E.

**PRELIMINARY ADJUSTMENT**

1. Turn all the adjusting screws until interference is noted, between the screw and the rocker arm, then check the torque required to turn the screw further. If the torque required to turn the screw is less than 3 foot-pounds (36 inch-pounds), try a new self locking adjusting screw. If this is still unsatisfactory, replace the rocker arm and adjusting screw.

**VALVE LASH ADJUSTMENT**

It is very important that the valve lash be held as close as possible to correct specifications. If the lash is too close, the valve will open early and close too late, resulting in rough engine idle. Burning and pre-ignition of the valves will occur also if the valves cannot make firm

The sending unit adapter is installed as shown in Fig. 32. Clean the adapter thoroughly. Coat the adapter with a light oil.

**100% GUARANTEED**

**BUY IT NOW!**

**Click Here To Order**

PayPal, American Express, Discover, MasterCard, VISA

2. Make three chalk marks on the crankshaft damper (Fig. 33). Space the marks approximately 90° apart so that with the timing mark, the damper is divided into four equal parts (90° represents ¼ of the distance around the damper circumference). Use a step-type feeler gauge ("go" and "no go") to adjust the valves. The preliminary (cold) intake and exhaust valve lash is given in Table 3.

3. Rotate the crankshaft until No. 1 piston is near T.D.C. at the end of the compression stroke, then adjust

the following valves:

No. 1—Exhaust No. 1—Intake  
No. 4—Exhaust No. 2—Intake  
No. 5—Exhaust No. 7—Intake

4. Rotate the crankshaft 180° or ½ turn (this puts No. 4 piston on T.D.C.), then adjust the following valves:

No. 6—Exhaust No. 4—Intake  
No. 8—Exhaust No. 5—Intake

5. Rotate the crankshaft 270°, or ¾ turn from 180° (this puts No. 3 piston on T.D.C.), then adjust the

following valves:

No. 2—Exhaust No. 3—Intake  
No. 3—Exhaust No. 6—Intake  
No. 7—Exhaust No. 8—Intake

#### FINAL ADJUSTMENT

Before a final valve lash adjustment is made, operate the engine for a minimum of 30 minutes at approximately 1200 rpm to stabilize engine temperatures. With the engine idling, check the valve lash, using a step-type feeler gauge only ("go" and "no go"). Adjust the lash if necessary (Fig. 34). The final (hot) intake and exhaust valve lash is given in Table 3.

**TABLE 3—Valve Lash Specifications**

Engine	Preliminary (Cold)		Final (Hot)	
	Intake	Exhaust	Intake	Exhaust
292 MD and HD V-8	0.019	0.019	0.018	0.018
302 and 332 HD V-8	0.020	0.022	0.020	0.020

## 5 CRANKSHAFT DAMPER, CYLINDER FRONT COVER, AND TIMING CHAIN AND GEARS

### CRANKSHAFT DAMPER

#### REMOVAL

On a P-series truck, remove the hood. Remove the grille, headlamps, parking lamps, wind deflector, and hood lower weatherstrip as an assembly. Remove the fan, spacer, hub, and drive belt, and the radiator and shroud assembly. Remove the cap screw and washer from the end of the crankshaft, then remove the damper (Fig. 35).

On the F-100 thru F-700 and B-series, remove the fan shroud retaining bolts and move the shroud to the rear. Remove the fan, spacer, and fan belt. Remove the capscrew and washer from the end of the crankshaft, then remove the damper (Fig. 35).

On the F-750 thru F-900 and the T-700 and 800, remove the fan, pulley, drive belt and mounting bracket. Remove the radiator and shroud assembly. Remove the capscrew and washer from the end of the crankshaft, then remove the damper (Fig. 35).

On a C-series truck, remove the hood and gain the cooling system and

the end of the crankshaft, then remove the damper (Fig. 35).

#### INSTALLATION

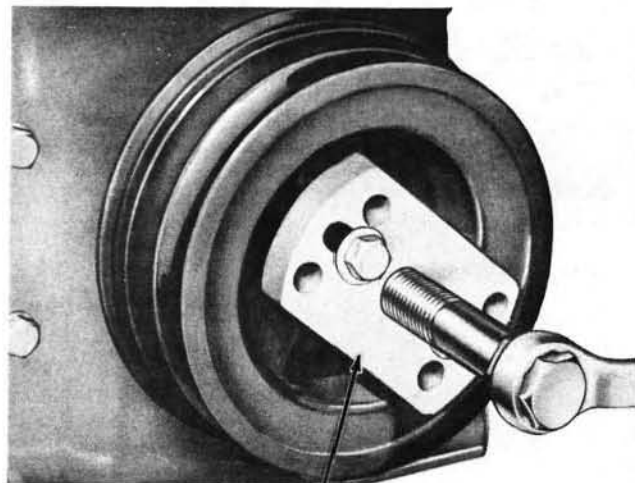
Lubricate the crankshaft with a white lead and oil mixture, and the oil seal rubbing surface with grease. Align the damper keyway with the key in the crankshaft, and start the damper on the shaft (Fig. 36). Install the washer and capscrew, then tighten the screw to 85-95 foot-pounds torque (292 engine) or 130-145 foot-pounds torque (302 or 332 engine).

On a P-series truck, install the radi-

ator and shroud assembly, and the drive belt, spacer hub, and fan. Fill the cooling system. Install the grille, headlamps, parking lamps, wind deflector, and hood lower weatherstrip. Install the hood.

On the F-100 thru F-700 and B-series, install the drive belt, spacer, and fan. Install the fan shroud.

On the F-750 thru F-900 and the T-700 and 800, install the radiator and shroud assembly, the drive belt, and the fan, pulley, and mounting bracket.



Tool — T52L-6316-FEE

1107-B

**FIG. 35—Damper Removal—Typical**

**100% SATISFACTION GUARANTEED**

**BUY IT NOW!**

**Click Here To Order**

MOVE THE CAPSCREW AND WASHER FROM

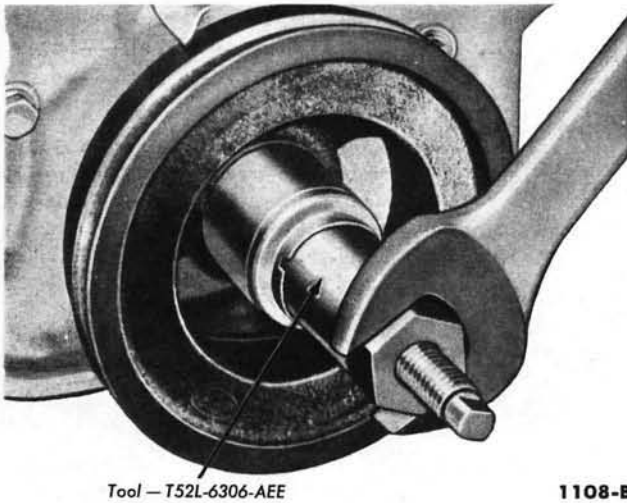


FIG. 36—Damper Installation—Typical

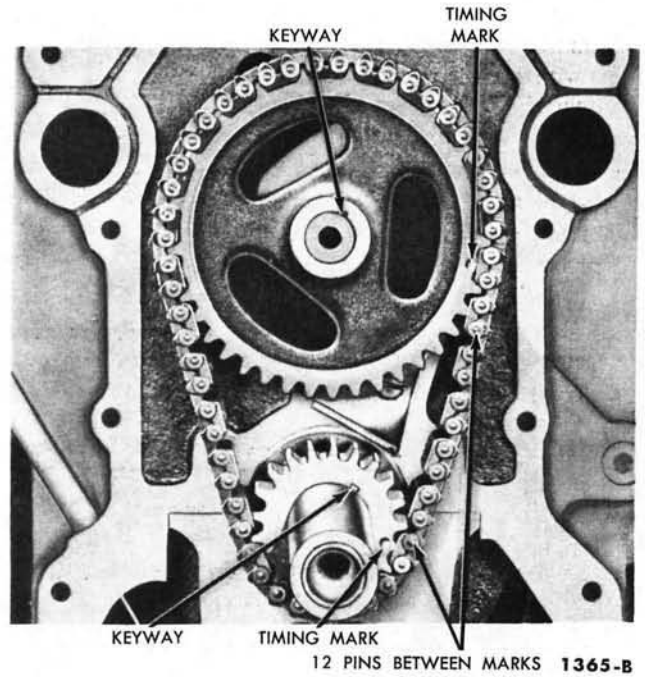


FIG. 37—Aligning Timing Marks—292 Engine

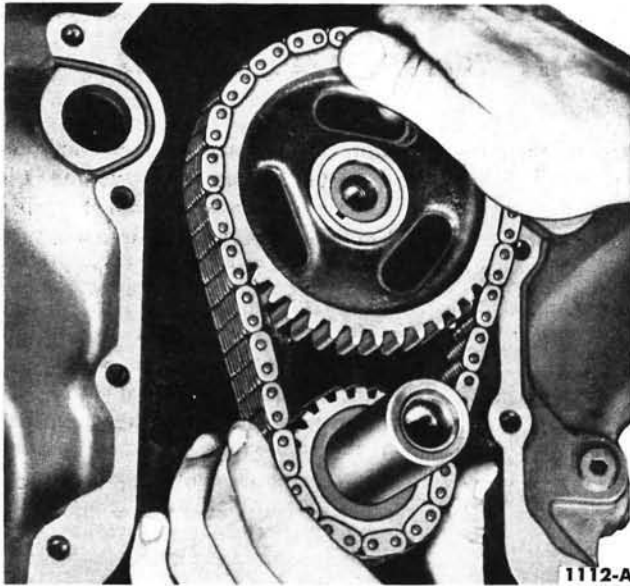


FIG. 38—Timing Chain and Sprockets Removal or Installation—292 Engine

On a C-series truck, install the generator belt. Install the heater hose retainer and the carburetor cable clamps to the radiator. Connect the radiator upper and lower hoses. Install the fan. Fill and bleed the cooling system.

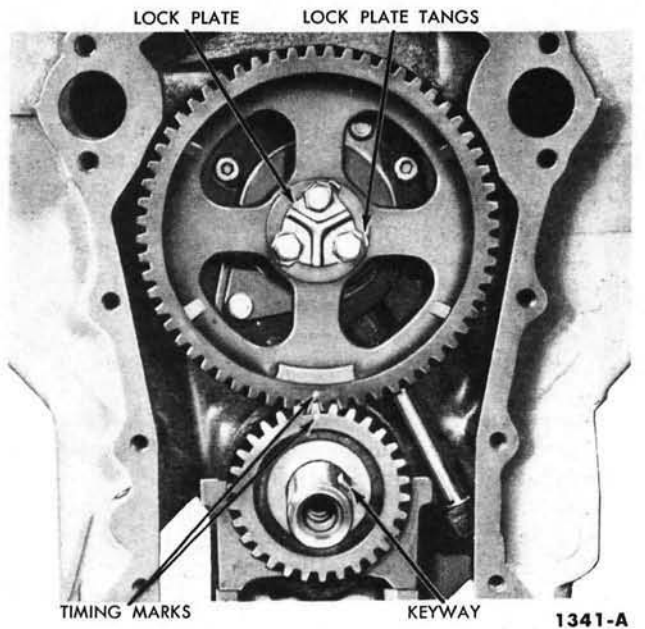


FIG. 39—Timing Gear Alignment—302 or 332 Engine

shaft damper, and remove the fuel pump from a 292 engine. Support the front of the engine. Remove the front support insulator bolts and the front of the engine slightly. Remove the bolts retaining the front support bracket to the cylinder front cover and remove the bracket. Re-

move the remaining cylinder front cover retaining bolts and remove the cover. Discard the cylinder front cover gasket.

2. Remove the crankshaft front oil slinger.

On a 292 engine, crank the engine until the timing marks on the sprock-

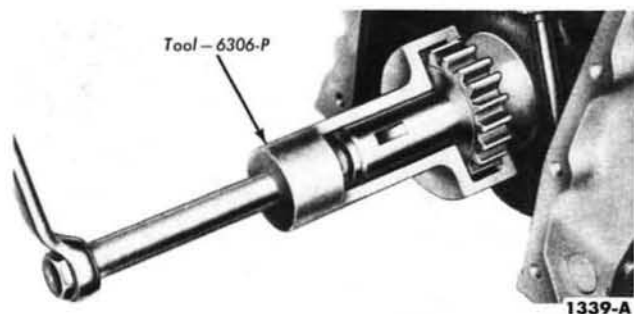
CYLINDER FRONT COVER  
AND TIMING CHAIN AND



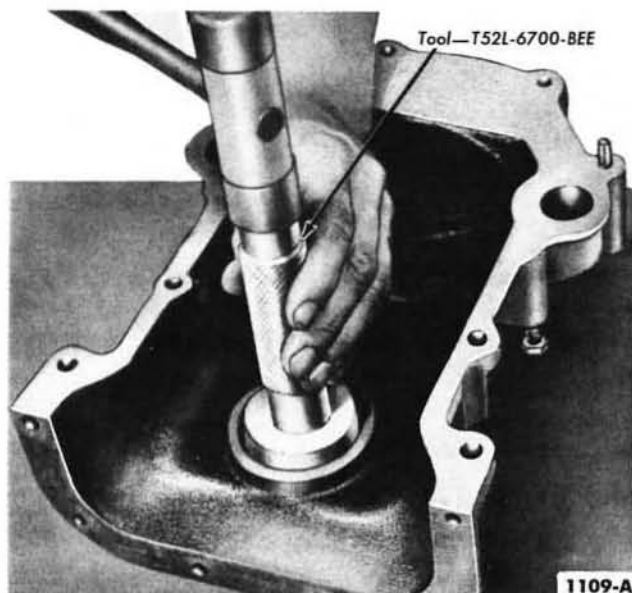
**BUY IT NOW!**

**Click Here To Order**

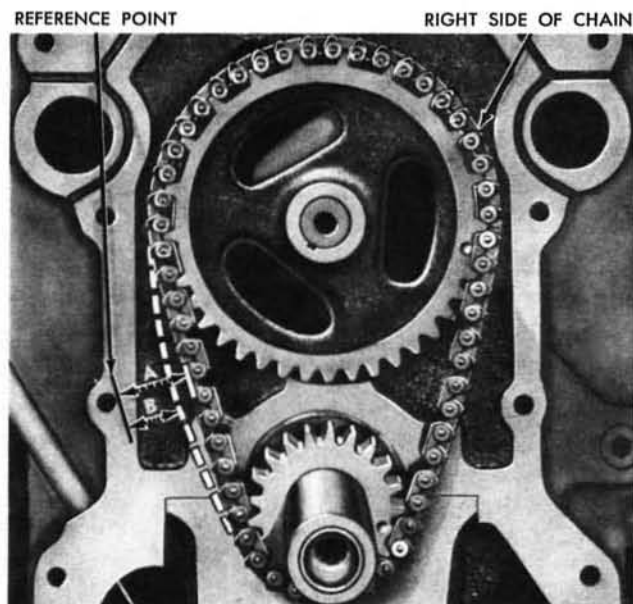




**FIG. 40—Crankshaft Gear Removal—302 or 332 Engine**



**FIG. 41—Oil Seal Installation**



**FIG. 42—Timing Chain Deflection—292 Engine**

ets and chain are positioned as shown in Fig. 37. Remove the camshaft sprocket cap screw, washer, and spacer. Remove the fuel pump eccentric. Slide both sprockets and the timing chain forward, and remove the sprockets and the timing chain as an assembly (Fig. 38).

On a 302 and 332 engine, crank the engine until the timing marks on the gears are aligned as shown in Fig. 39. Remove the three capscrews and the lock plate securing the camshaft to the camshaft and remove

1. Drive out the crankshaft oil seal with a pin punch, then clean out the recess in the cover.

2. Coat a new seal with grease, then install the seal (Fig. 41). Drive the seal in until it is fully seated in the recess. Check the installation to be sure the spring is properly positioned in the seal.

#### INSTALLATION

1. Place the keys in position in the slots on the crankshaft and camshaft.

2. On a 292 engine, position the sprockets and timing chain on the camshaft and crankshaft (Fig. 38). Be sure the timing marks on the sprockets and chain are positioned as shown in Fig. 37. There are 12 timing chain link pins between the timing marks on the sprockets.

Rotate the crankshaft in a clockwise direction (as viewed from the front) to take up the slack on the left side of the chain. Establish a reference point on the block and measure from this point to the chain (Fig. 42). Rotate the crankshaft in the opposite direction to take up the slack on the right side of the chain, then force the left side of the chain out with the fingers and measure the distance between the reference point and the chain. The deflection is the difference between the two measurements. The deflection should not exceed  $\frac{1}{2}$  inch.

Install the counterweight and fuel pump eccentric (Fig. 43). Install the spacer, flat washer, lockwasher, and camshaft sprocket capscrew. Tighten the capscrew to 35-45 foot-pounds torque. Install the crankshaft front oil slinger.

3. On a 302 or 332 engine, install the crankshaft gear (Fig. 44) and the camshaft gear with the timing marks aligned (Fig. 39). Install a new lock plate and install the three capscrews. Tighten the capscrews to 15-18 foot-pounds torque. Bend the tangs on the lock plate over the retaining screws. Install the crankshaft front oil slinger.

4. Clean the cylinder front cover and the gasket surface of the cylinder block. Coat the gasket surface of the block and cover, and the cover bolt threads with sealer. Position a new gasket on the block. Insert the large diameter end of the oil seal pilot in the bore of the cover of the 292

**100% SATISFACTION GUARANTEED**

**BUY IT NOW!**

**Click Here To Order**

PayPal | American Express | Discover | MasterCard | VISA

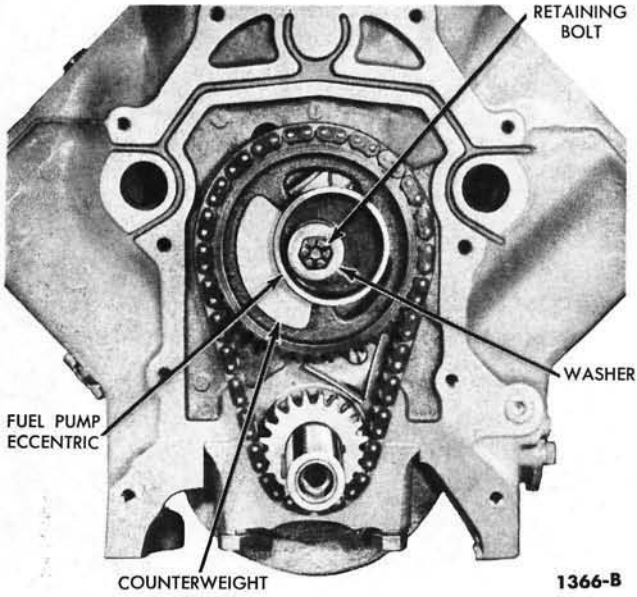


FIG. 43—Fuel Pump Eccentric and Counterweight Installed—292 Engine

engine. On a 302 or 332 engine, insert the small diameter end of the tool in the bore of the cover. Position the cover and pilot assembly over the end of the crankshaft and against the block (Fig. 45). Install the bolts that retain the cylinder front cover and the engine front support bracket to the block. While pushing in on the pilot, install and tighten the bolts. Tighten the 3/8-inch bolts to 23-28 foot-pounds torque, and the 1/8-inch bolts to 12-15 foot-pounds torque.

5. Install the crankshaft damper, the fan, drive belts, fuel pump (292 engine), and the oil pan. Adjust the tension of the drive belts. Install the radiator. Fill the crankcase. Fill and bleed the cooling system. Operate the engine and check for coolant and oil leaks.

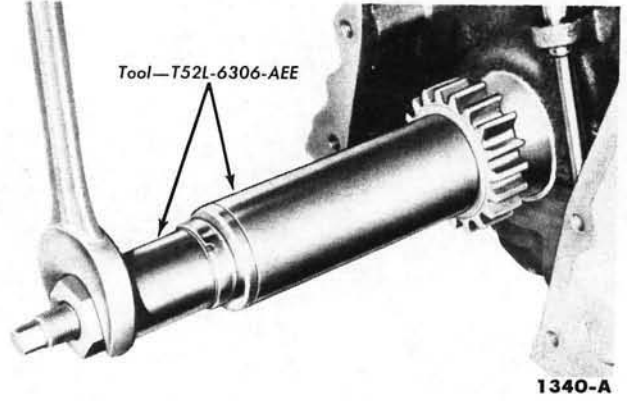


FIG. 44—Crankshaft Gear Installation—302 or 332 Engine

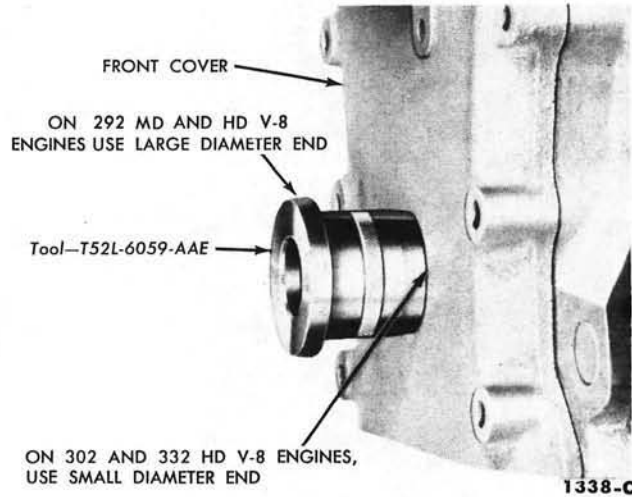


FIG. 45—Cylinder Front Cover Alignment

## 6 CAMSHAFT, BEARINGS, AND TAPPETS

### CAMSHAFT

#### 292 ENGINES

The camshaft and related parts are shown in Fig. 46.

2. Remove the intake manifold, the valve rocker arm covers, and both valve rocker arm shaft assemblies. Remove the push rods and the valve rod chamber cover.

Crank the engine until the timemarks on the sprockets are positioned as shown in Fig. 37.

Remove the distributor cap,

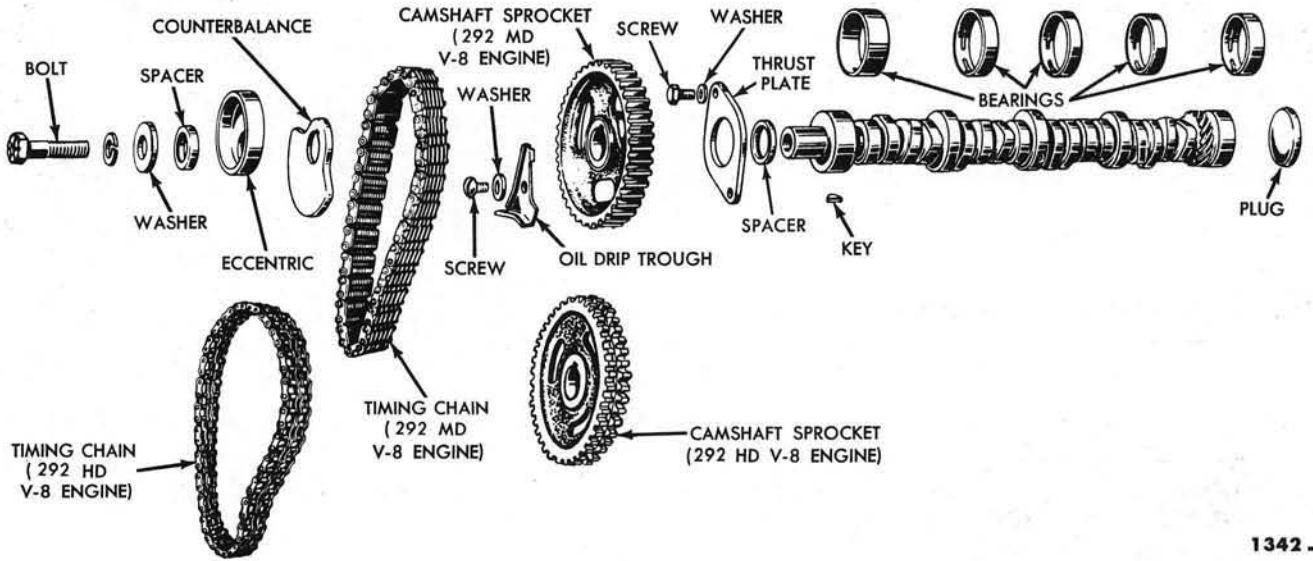
then scribe a line on the distributor housing and cylinder block to mark the position of the rotor, and the distributor housing. Remove the distributor.

5. Remove the crankshaft front oil slinger, camshaft sprocket bolt, washer, spacer, fuel pump eccentric, and counterweight.

100% SATISFACTION GUARANTEED

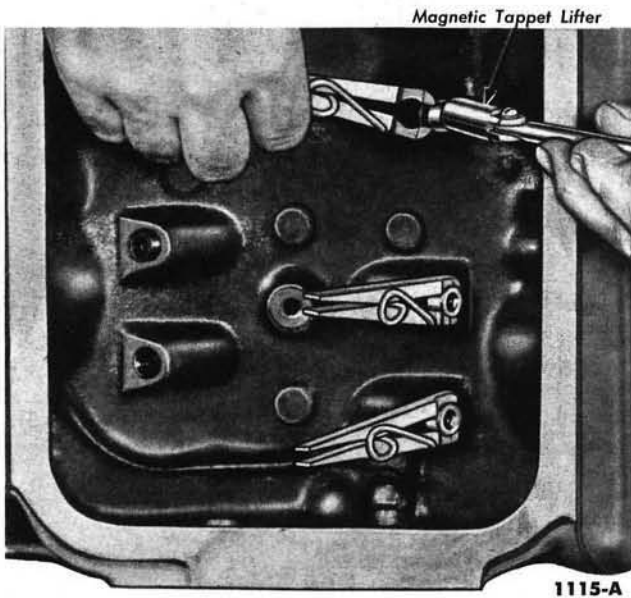
**BUY IT NOW!**

Click Here To Order



1342 -C

FIG. 46—Camshaft and Related Parts—292 Engine



1115-A

FIG. 47—Lifting and Securing Valve Tappets—292 Engine

6. Remove the sprocket and timing chain as an assembly (Fig. 38). Remove the woodruff key, thrust plate, and spacer.

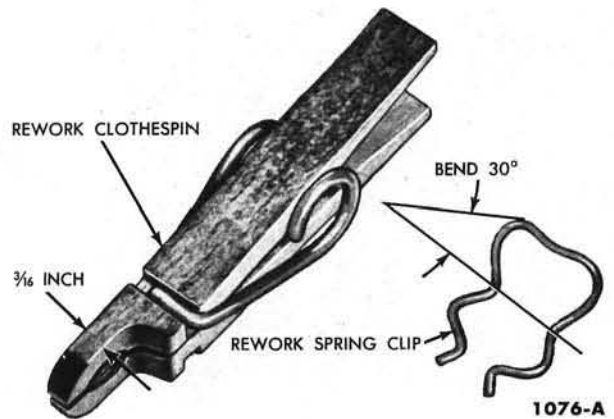
7. Turn the camshaft until the counterbalance can be lifted with either a magnetic tappet lifter or the spacers (Fig. 47). Do not

engine. Exercise caution to avoid damaging the camshaft bearings.

**Installation**

1. Oil the camshaft and carefully slide it through the bearings. Install the spacer. **Be sure the chamfer on the inside of the spacer is to the rear, or faces the camshaft when it is installed.** Install the thrust plate and woodruff key.

2. Install the sprockets and timing chain (Fig. 38), the counterweight,



1076-A

FIG. 48—Tappet Retainers—292 Engine

fuel pump eccentric, spacer, flat washer, lockwasher, and camshaft sprocket cap screw. Tighten the cap screw to 35-45 foot-pounds torque.

3. Install the crankshaft front oil slinger, cylinder front cover, oil pan, crankshaft damper, and drive belts. Install the fan, fuel pump, and radiator.

4. Release the tappets and install the push rods, then install the valve rocker arm shaft assemblies. Perform a preliminary valve lash adjustment. Clean the valve push rod chamber cover and the mating surface of the block. Apply sealer to the cover gasket and position it on the block, then install the cover. Install the intake manifold and carburetor, as an assembly. Connect the carburetor link-

**100% SATISFACTION GUARANTEED**

**BUY IT NOW!**

**Click Here To Order**

PayPal, American Express, Discover, MasterCard, VISA

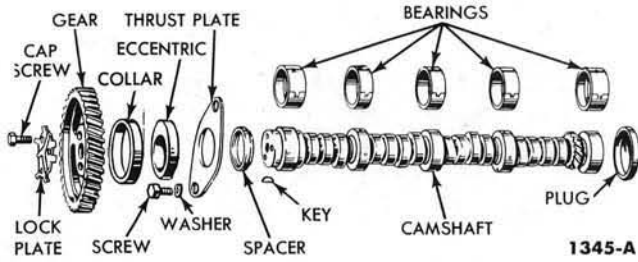


FIG. 49—Camshaft and Related Parts—302 or 332 Engine

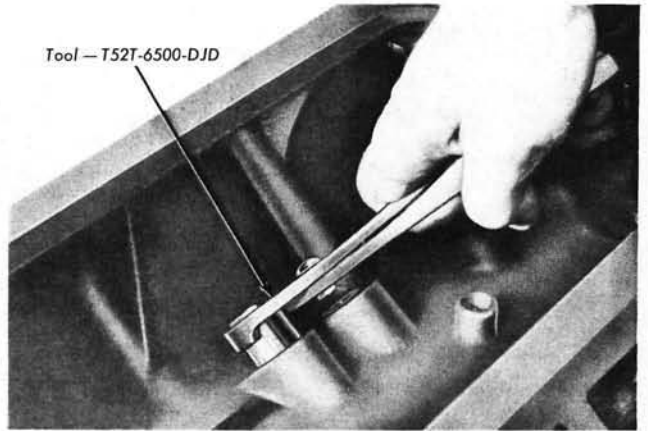


FIG. 50—Valve Tappet Removal—302 or 332 Engine

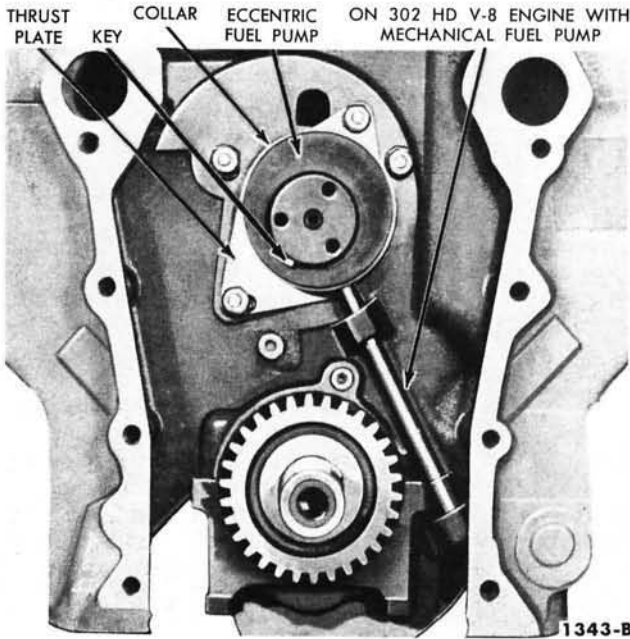


FIG. 51—Fuel Pump Eccentric Installed—302 or 332 Engine

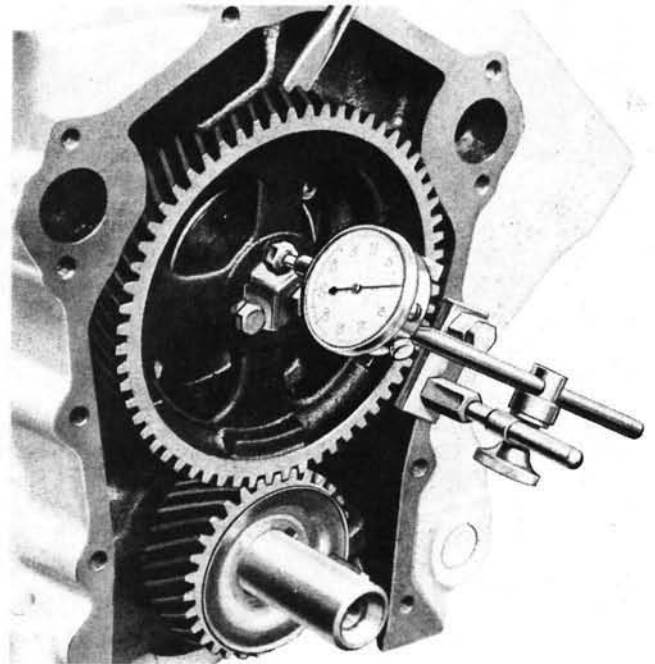


FIG. 52—Camshaft End Play—302 or 332 Engine

age. Position the fuel pump and install the retaining bolts. Connect the carburetor fuel inlet line, vacuum lines, and the flexible fuel line. Install the radiator.

5. If the crankshaft has not been rotated, install the distributor using the marks previously scribed on the distributor body and engine block as guides.

If the crankshaft has been rotated, crank the engine until No. 1 piston is on T.D.C., then position the distributor in the block with the rotor at the No. 1 firing position and the breaker point at the top. Install the hold down

tem. Fill the crankcase with the proper grade and quantity of engine oil. Start the engine and adjust the ignition timing. Operate the engine at fast idle and check all hose connections and gaskets for leaks. Make a final (hot) valve lash adjustment with the engine idling. Install the valve cover arm covers. Install the air filter.

**Removal**

1. Perform steps 1 through 4 under the camshaft removal procedure for the 292 engine.

2. Remove the camshaft gear, fuel pump eccentric, thrust plate, woodruff key, and spacer. Remove the valve tappets (Fig. 50). Keep the tappets in order so they can be replaced in their original position.

3. Carefully remove the camshaft by pulling it toward the front of the engine. Exercise caution to avoid damaging the camshaft bearings.

**AND 332 ENGINES**

Remove the camshaft and related parts as shown in Fig. 49.

**100% SATISFACTION GUARANTEED**

**BUY IT NOW!**

**Click Here To Order**

PayPal, American Express, Discover, MasterCard, VISA

Tool—T52L-6261-CEE  
 Adapter—T56T-6250-A (Remover or Replacer) NO. 1 BEARING, 302 AND 332 HD V-8 ENGINES  
 Adapter—T54T-6250-B (Remover, Detail 1; Replacer, Detail 2) NO. 2, 3, 4 OR 5 BEARINGS, 302 AND 332 HD V-8 ENGINES  
 Adapter—T54T-6250-B (Remover, Detail 1; Replacer, Detail 2) 292 MD AND HD V-8 ENGINES

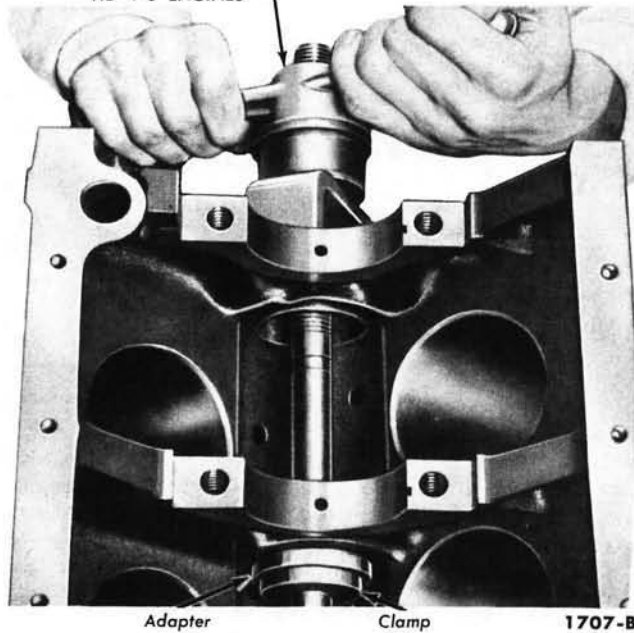


FIG. 53—Camshaft Bearing Removal or Installation—Typical

#### Installation

1. Oil the camshaft and carefully slide it through the bearings. Install the spacer and thrust plate. **Be sure the chamfer on the inside of the spacer is to the rear, or faces the camshaft when it is installed.**

2. Tighten the retaining bolts to 12-15 foot-pounds torque. Install the woodruff key, fuel pump eccentric, and collar (Fig. 51).

3. Install the camshaft timing gear, lock plate, and retaining bolts (Fig. 39).

4. Push the camshaft toward the rear of the engine. Place a dial indicator so the point rests against one of the camshaft gear retaining bolts (Fig. 52). Set the dial on zero, then pull the camshaft forward and release it. Compare the dial reading with specifications. If the end play is excessive, check the spacer for correct installation. Replace the thrust plate and/or spacer if necessary.

5. Install the cylinder front cover, lift damper, and drive belts.

rotated, install the distributor using the marks previously scribed on the distributor body and engine block as guides.

If the crankshaft has been rotated, crank the engine until No. 1 piston is on T.D.C., then position the distributor in the block with the rotor at the No. 1 firing position and the breaker points open and install the hold down clamp.

9. Install the valve push rod chamber cover. Install the intake manifold. Connect the fuel lines, and accelerator linkage. Install the carburetor air cleaner. Fill and bleed the cooling system. Fill the crankcase.

10. Make a preliminary (cold) valve lash adjustment. Operate the engine for a minimum of 30 minutes at approximately 1200 rpm, then make a final (hot) valve lash adjustment with the engine idling. Check for oil and coolant leaks. Install the valve rocker arm covers. Check and adjust the ignition timing.

#### BEARING REPLACEMENT

It will be necessary to remove the engine from the truck to replace camshaft bearings. Camshaft bearings are available pre-finished to size for standard and 0.015-inch undersize

Tool—T52L-6266-BGD  
 292 MD AND  
 HD V-8 ENGINES  
 Tool—T52T-6266-CJD  
 302 AND 332 HD V-8  
 ENGINES

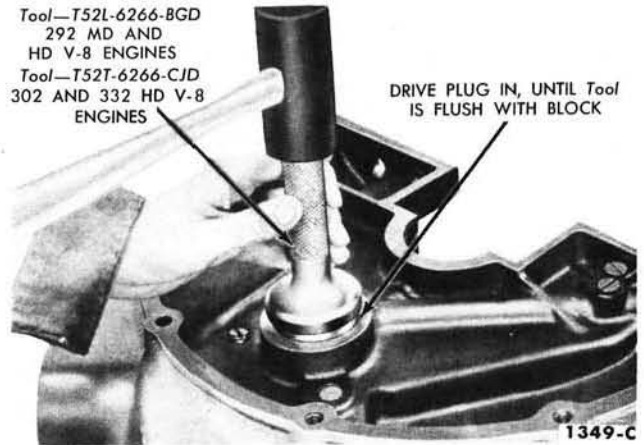


FIG. 54—Camshaft Rear Bearing Bore Plug Installation—Typical

journal diameters. The No. 1 camshaft bearing is not interchangeable with the other bearings.

1. Remove the engine and mount it on a work stand. Remove the flywheel, crankshaft, and the camshaft. Push the pistons to the top of the cylinders to move the connecting rods out of the way.

2. Drill a 1/2-inch hole in the camshaft rear bearing bore plug and use tool 7600-E to remove the plug. Remove the camshaft bearings (Fig. 53).

3. Position the bearing at the bearing bore, and press it in place (Fig. 53). **Be sure the front bearing is installed 0.005-0.020 inch (292 engine) or 0.002-0.020 inch (302 or 332 engine) below the front face of the cylinder block.** Align the oil holes in the bearings with the oil holes in the cylinder block when the bearings are installed. Particular care should be taken with the No. 3 bearing since it supplies oil to the valve rocker arms.

4. Clean the camshaft rear bearing bore plug recess thoroughly. Coat the flange of a new plug with water resistant sealer and install it with the flange facing in (Fig. 54). Drive the plug in until the flange is flush or slightly below the casting surface.

5. Install the camshaft, crankshaft, flywheel, and related parts. Install the engine in the chassis.

#### TAPPET REPLACEMENT

##### 292 ENGINE

Remove the camshaft. Remove and install one tappet at a time through the bottom of the block. A flexible type holding tool can be used for this operation. As each new tappet is installed, it should be secured in the up position.

**100% SATISFACTION GUARANTEED**

**BUY IT NOW!**

**Click Here To Order**

PayPal, American Express, Discover, MasterCard, VISA

After the tappets are installed, install the camshaft.

### 302 AND 332 ENGINES

Remove the intake manifold, the valve rocker arm covers, and the valve rocker arm shaft assemblies. Remove the push rods and the valve push rod chamber cover.

Oil the new tappets before installation. Remove and replace one tappet at a time. If the tappets are difficult to remove, use the tool shown in Fig. 50.

Install the push rods in their proper location. Install the push rod chamber cover, the intake manifold, and the rocker arm assemblies.

Make a preliminary (cold) valve lash adjustment. Run the engine for a minimum of 30 minutes at approximately 1200 rpm, then make a final (hot) valve lash adjustment with the engine idling. Check for oil and coolant leaks. Install the valve rocker arm covers.

## 7 FLYWHEEL, CRANKSHAFT, CONNECTING RODS, AND PISTON ASSEMBLIES

### FLYWHEEL

The procedure for replacing the clutch pilot bushing is covered in Part 3-1.

### FLYWHEEL REMOVAL

1. Disconnect the transmission from the engine and slide it to the rear as outlined in Group 3 (manual-shift transmissions) or Group 4 or 5 (automatic transmissions).

2. On a manual-shift transmission, remove the pressure plate and cover assembly and the clutch disc as outlined in Part 3-1.

3. Remove the flywheel retaining bolts and remove the flywheel.

### RING GEAR REPLACEMENT— MANUAL-SHIFT TRANSMISSION FLYWHEEL

Heat the defective ring gear with a blow torch on the engine side of the gear, then knock it off the flywheel. **Do not hit the flywheel when removing the ring gear.**

Heat the new ring gear evenly until the gear expands enough to slip onto the flywheel. Make sure the gear is seated properly against the shoulder. **Do not heat any portion of the gear to a temperature higher than 500°F. If this limit is exceeded, the temper will be removed from the ring gear teeth.**

### FLYWHEEL INSTALLATION

1. Position the flywheel on the crankshaft flange and install the mounting bolts. Tighten the bolts, in sequence across from each other, to specifications.

On a manual-shift transmission,

### CRANKSHAFT

The crankshaft and related parts are shown in Fig. 55 or 56.

### REMOVAL

1. Drain the cooling system and the crankcase. Remove the engine from the truck and install it on a work stand. Remove the oil pan, crankshaft damper, cylinder front cover, and flywheel.

On a 292 engine, remove the timing chain and sprockets.

On a 302 or 332 engine, remove the crankshaft gear.

2. Make sure all bearing caps (main and connecting rod) are marked so they can be installed in their original locations. Remove the connecting rod bearing caps, then carefully push the piston and connecting rod assemblies against the heads. Remove the main bearing caps (and rear oil seal retainer on a 292 engine).

3. Carefully lift the crankshaft out of the cylinder block so that the thrust bearing surfaces are not damaged. **Handle the crankshaft with care to avoid possible fracture or damage to the finished surfaces.** Remove the rear journal oil seal from the block and rear main bearing cap or rear oil seal retainer. Remove the retainer or rear main bearing cap to block side seals.

4. If new main and/or connecting rod bearings are to be installed, remove the main bearing inserts from the block and the bearing caps, and/or the connecting rod bearing inserts from the connecting rods and caps. Install new bearings following procedures in Section 8 "Main and Connecting Rod Bearing Replacement."

oil seal grooves are clean. Install a new rear journal oil seal in the block (Fig. 57) and rear journal oil seal retainer or rear bearing cap (Fig. 58). After installation, cut the ends of the seals flush.

2. Carefully lower the crankshaft into place. **Be careful not to damage the bearing surfaces.**

3. Check the clearance of each main bearing following the procedure under "Main Bearing Replacement" in Section 8. If the bearing clearances are satisfactory, apply a light coat of engine oil to the journals and bearings, then install all the bearing caps, except the thrust bearing cap (No. 3 bearing). Tighten the bearing cap bolts to specifications.

On a 302 or 332 engine, install new side seals when the rear main bearing cap is installed.

On a 292 engine, coat the rear oil seal retainer to block mating face with sealer, install the retainer and tighten the bolts to 23-28 foot-pounds torque.

To install the retainer or rear main bearing cap side seals, dip them in light engine oil and immediately install them in the grooves. It may be necessary to tap the seals into place for the last ½ inch of travel. Do not cut the seal projecting ends. **Do not use sealer on the side seals. The seals are designed to expand when dipped in oil. Using sealer may retard this expansion.** Check the retainer side seals for leaks by squirting a few drops of oil into the parting lines between the retainer and the cylinder block from the outside. Blow compressed air against the seals from the inside of the block. If air bubbles appear in the oil, it indicates possible oil leakage. **The above test should not be performed on newly installed seals until sufficient time has been allowed for the seals to expand into the seal grooves.**

en  
ual  
5 (

100% SATISFACTION GUARANTEED

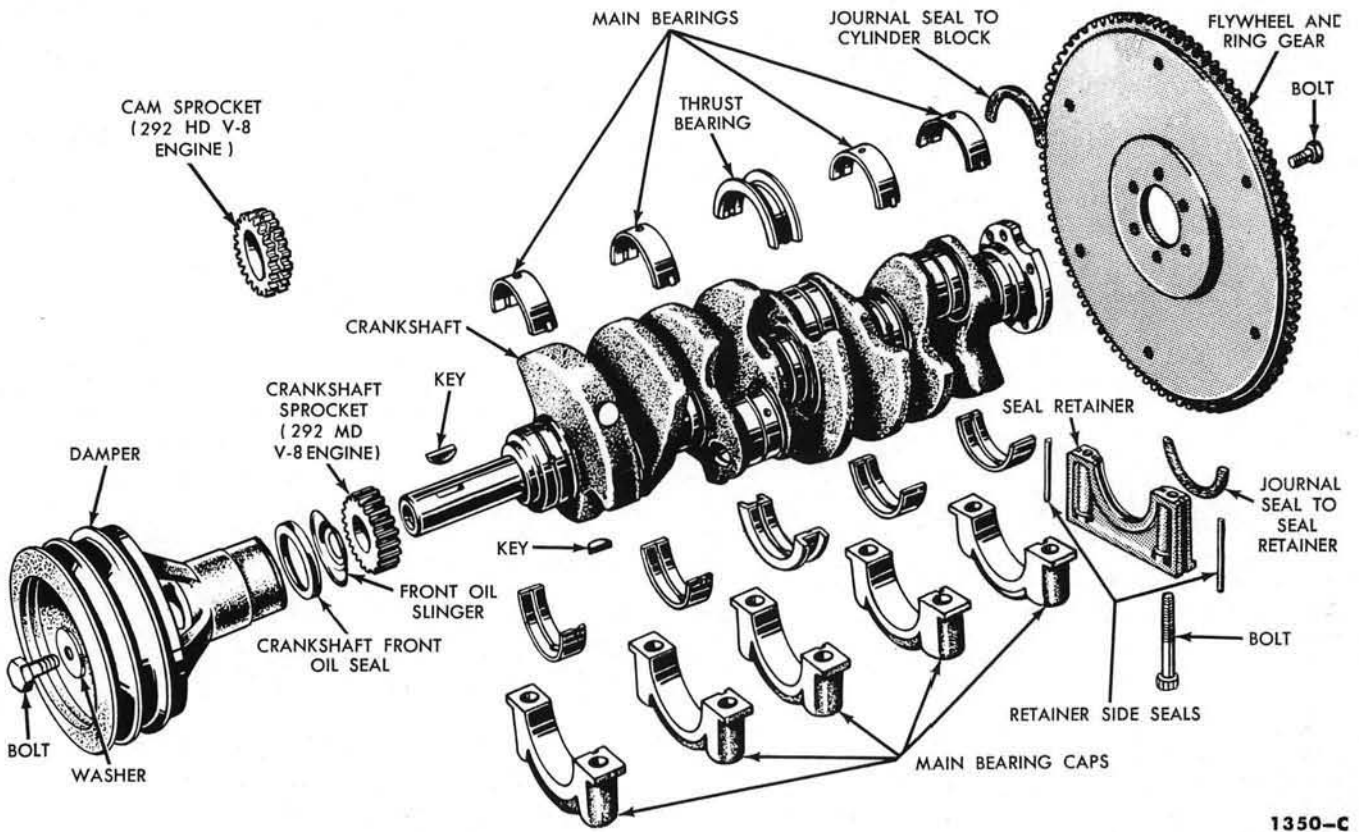
**BUY IT NOW!**

Click Here To Order

INSTALLATION

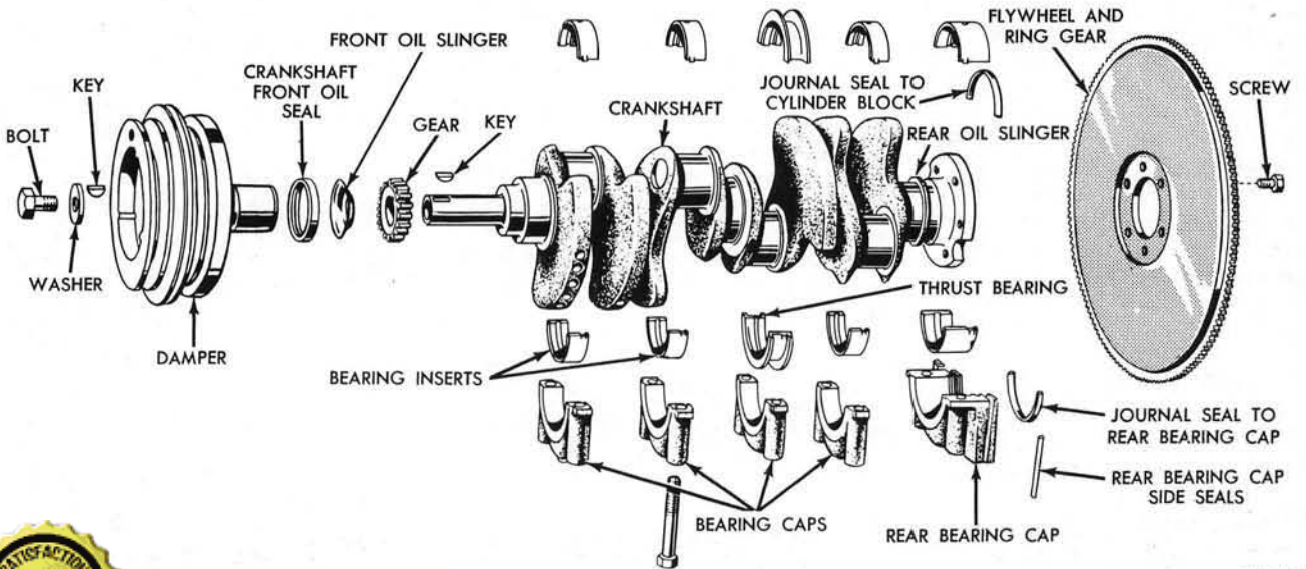
Be sure that all bearings, crank-journals, and the rear journal

PayPal American Express Discover Novus MasterCard VISA



1350-C

FIG. 55—Crankshaft and Related Parts—292 Engine



1344-B

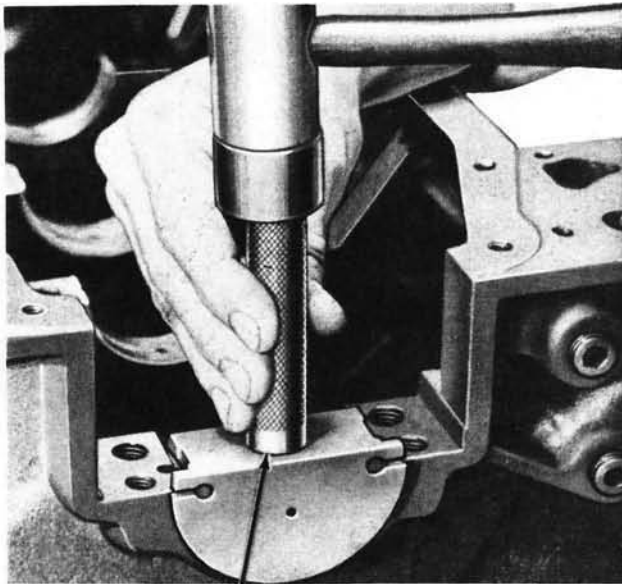


**BUY IT NOW!**

**Click Here To Order**

302 or 322 Engine





Tool—T52L-6701-AGD—292 MD AND HD V-8 ENGINES  
Tool—T52T-6701-AJD—302 AND 332 HD V-8 ENGINES

1254-C

FIG. 57—Seal To Block Installation—Typical

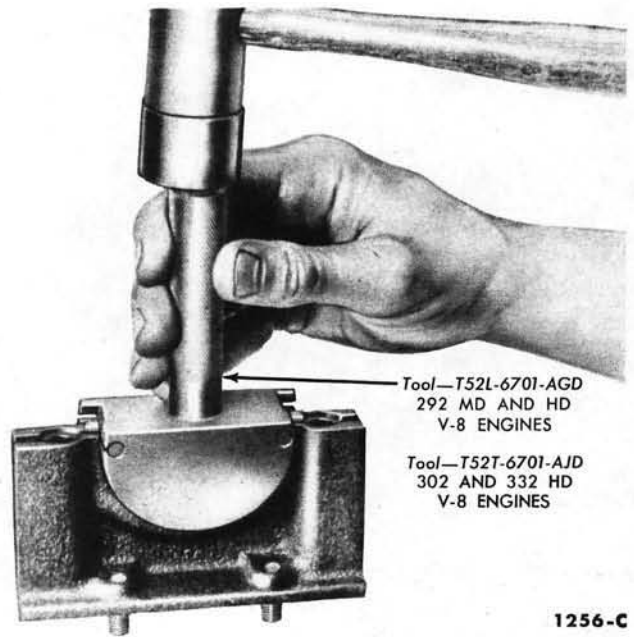
4. Install the thrust bearing cap with the bolts finger tight, then pry the crankshaft forward against the thrust surface of the upper half of the bearing (Fig. 59). Hold the crankshaft forward and pry the thrust bearing cap to the rear (Fig. 59). This will align the thrust surfaces of both halves of the bearing. Retain the forward pressure on the crankshaft and tighten the cap bolts to specifications (Fig. 59).

5. Force the crankshaft toward the rear of the engine. Install a dial indicator so the contact point rests against the crankshaft flange and the indicator axis is parallel to the crankshaft axis (Fig. 60). Set the dial on zero, then push the crankshaft forward and note the reading on the dial.

If the end play exceeds the wear

limit, replace the thrust bearing. If the end play is less than the minimum limit, inspect the thrust bearing faces for scratches, burrs, nicks, or dirt. If the thrust faces are not defective or dirty, they probably were not aligned properly. Install the thrust bearing and align the faces following the recommended procedure (step 4), then recheck the end play.

6. Check the clearance of each connecting rod bearing following the procedure under "Connecting Rod Bearing Replacement" in Section 8. If the bearing clearances are satisfactory, apply a light coat of engine oil to the journals and bearings, then install the connecting rod caps. Tighten all the nuts to 45-50 foot-pounds torque.



Tool—T52L-6701-AGD  
292 MD AND HD  
V-8 ENGINES

Tool—T52T-6701-AJD  
302 AND 332 HD  
V-8 ENGINES

1256-C

FIG. 58—Seal To Bearing Cap or Retainer Installation—Typical

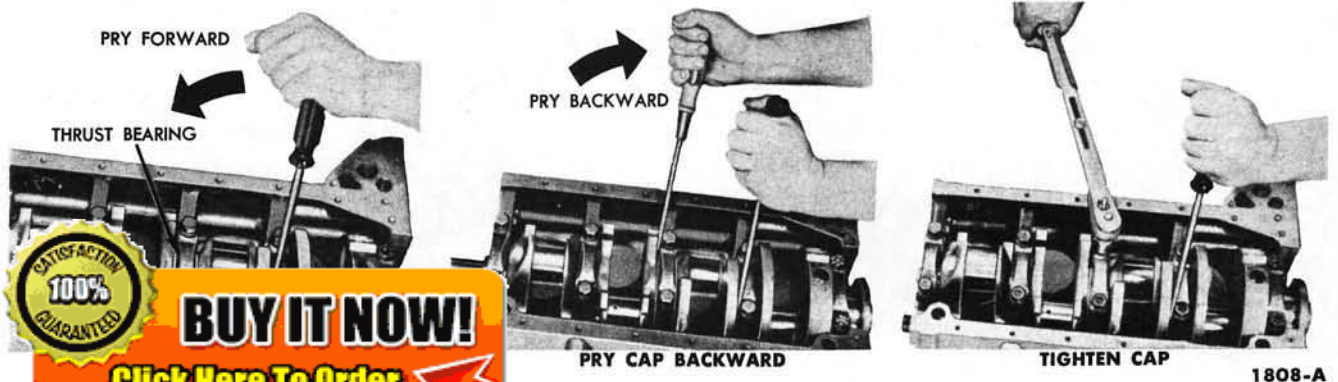
On a 302 or 332 engine, install the pal nuts and tighten them to 3-4 foot-pounds torque.

Check the side clearance between the connecting rods on each connecting rod crankshaft journal following the procedure under "Piston and Connecting Rod Installation."

7. Install the flywheel.

On a 292 engine, install the sprockets and timing chain with the timing marks aligned (Fig. 37). Install the counterweight, fuel pump eccentric, spacer, washers, and the camshaft sprocket bolt. Tighten the bolt to 35-45 foot-pounds torque.

On a 302 or 332 engine, install the crankshaft gear (Fig. 44) with the timing mark aligned with the timing



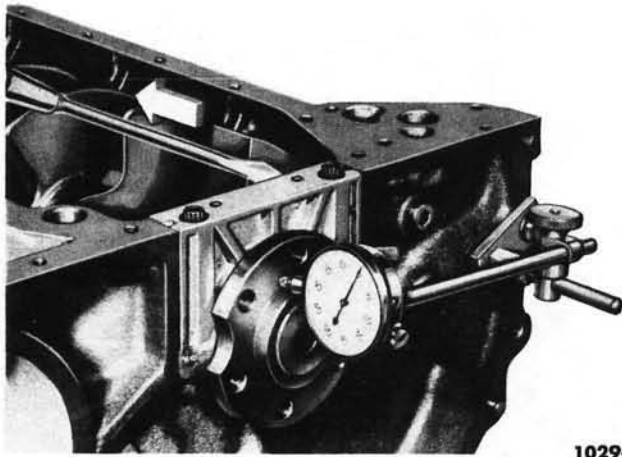
1808-A

100% SATISFACTION GUARANTEED

**BUY IT NOW!**

Click Here To Order

PayPal American Express Discover/Novus MasterCard VISA



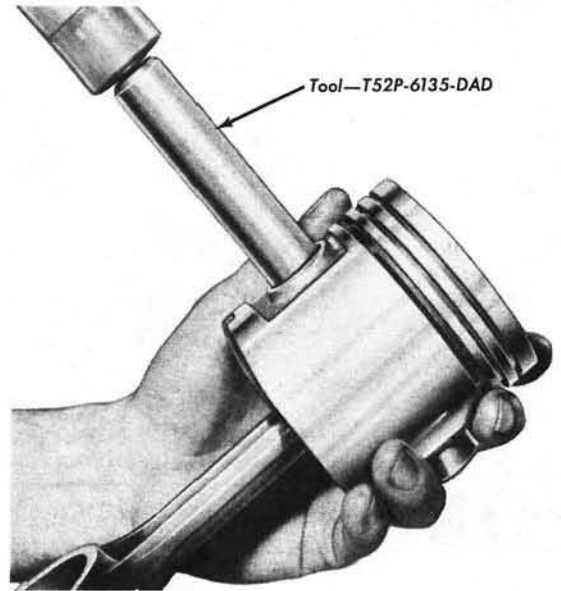
1029-A

FIG. 60—Crankshaft End Play

mark on the camshaft gear (Fig. 39).

8. Install the crankshaft front oil slinger, cylinder front cover, crankshaft damper, fuel pump (on a 292 or 302 engine), generator, and drive belts. Install the oil pan, oil pump, and oil pump inlet tube.

9. Install the engine in the chassis. Install the radiator. Fill and bleed the cooling system. Fill the crankcase with the proper grade and quantity of engine oil. Start the engine and check and adjust the ignition timing. Operate the engine at fast idle and check for oil pressure and check all hose



1119-B

FIG. 62—Piston Pin Removal

connections and gaskets for leaks.

**PISTON AND CONNECTING ROD REMOVAL**

The piston and connecting rod assembly is shown in Fig. 61.

1. Drain the cooling system and the crankcase. Remove the intake manifold and carburetor as an assem-

bly. Remove the valve rocker arm covers, the valve rocker arm shaft assemblies, the valve push rods in sequence, the exhaust manifolds, and the cylinder heads. Remove the oil pan.

2. Before removing the piston assemblies, remove any ridge and/or deposits from the upper end of the

1347-C

Related Parts

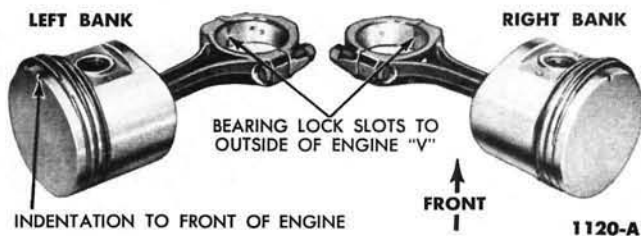


FIG. 63—Connecting Rod and Piston Assembly—Typical

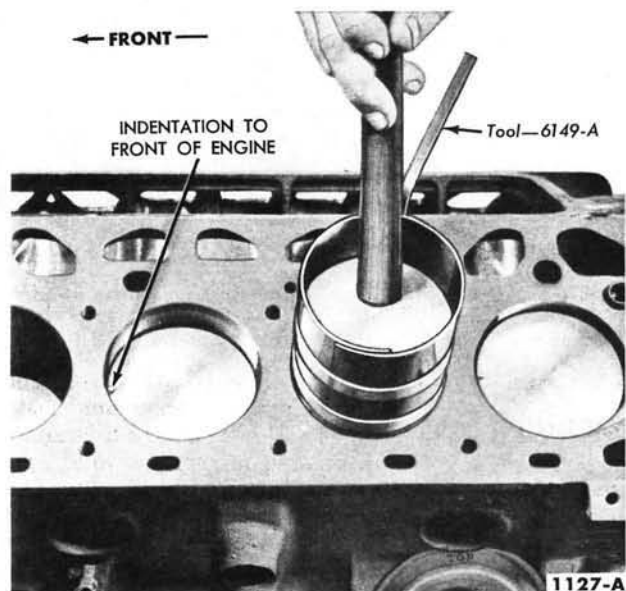


FIG. 65—Piston Installation

cylinder bores. Move the piston to the bottom of its travel and place a cloth on the piston head to collect the cuttings. Remove the cylinder ridge with a ridge cutter. Follow the instructions furnished by the tool manufacturer. **Never cut into the ring travel area in excess of 1/32 inch when removing ridges.** After the ridge has been removed, remove the cutter from the cylinder bore, then turn the crankshaft until the piston is at the top of its stroke and carefully remove the cloth with the cuttings.

3. Turn the crankshaft until the connecting rod being removed is down. Remove the connecting rod cap. Push the connecting rod and bearing assembly out the top of the cylinder with the handle end of a

cylinder wall by passing a fine grit hone or glaze removal tool through the bore a few times. Do not hone more than enough to rough up the finish. Thoroughly clean the cylinder walls and block after the glaze is removed, then oil the cylinder walls.

5. Repeat this procedure on each assembly.

#### PISTON AND CONNECTING ROD DISASSEMBLY

Mark the pistons and pins to assure assembly with the same connecting rod and installation in the same cylinder from which they were removed. Remove the piston rings. Remove the piston pin retainers, then drive the pin out of the piston and rod (Fig. 62). Discard the retainers.

#### PISTON AND CONNECTING ROD ASSEMBLY

1. Lubricate all parts with light engine oil. Position the connecting rod in the piston and push the pin into place. Assemble the piston and



FIG. 64—Ring Side Clearance—Typical

connecting rod with the oil squirt hole in the connecting rod positioned as shown in Fig. 63.

2. Insert new piston pin retainers by spiraling them into the piston with the fingers. Do not use pliers. Follow the instructions contained on the piston ring package and install the piston rings.

3. Check the ring side clearance of the compression rings with a feeler gauge inserted between the ring and its lower land (Fig. 64). The gauge should slide freely around the entire ring circumference without binding. Any wear that occurs will form a step at the inner portion of the lower land. **If the lower lands have high steps, the piston should be replaced.**

4. Be sure the bearings and journals are clean. If it is necessary to replace the connecting rod bearings, replace them at this time following the procedure under "Connecting Rod Bearing Replacement," in Section 8.

#### PISTON AND CONNECTING ROD INSTALLATION

Be sure to install the pistons in the same cylinders from which they were removed, or to which they were fitted. Each connecting rod and bearing cap is numbered from 1 to 4 in the right bank and from 5 to 8 in the left bank, beginning at the front of the engine. The numbers on the connecting rod and bearing cap must be on the same

**100% SATISFACTION GUARANTEED**

**BUY IT NOW!**

**Click Here To Order**

PayPal   American Express   Discover   MasterCard   VISA

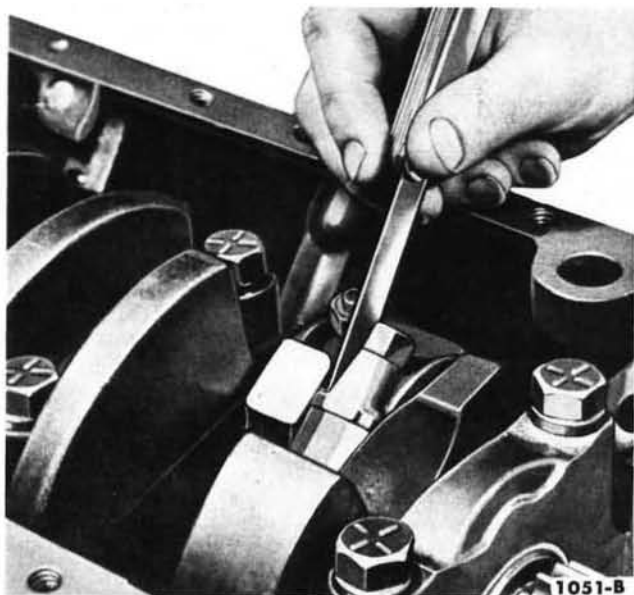


FIG. 66—Connecting Rod Side Clearance—Typical

side when installed in the cylinder bore. If a connecting rod is ever transposed from one block or cylinder to another, new bearings should be fitted and the connecting rod should be numbered to correspond with the new cylinder number.

1. Oil the piston rings, pistons, and cylinder walls with light engine oil.

2. Make sure the ring gaps are properly spaced around the circumference of the piston. Install a piston ring compressor on the piston and

push the piston in with a hammer handle until it is slightly below the top of the cylinder (Fig. 65). Be sure to guide the connecting rods to avoid damaging the crankshaft journals. Install the piston with the indentation in the piston head toward the front of the engine. When installed, the rod bearing lock slots in the connecting rod should be toward the outside of the engine.

3. Check the clearance of each bearing following the procedure un-

der "Connecting Rod Bearing Replacement" in Section 8. If the bearing clearances are to specifications apply a light coat of engine oil to the journals and bearings.

4. Turn the crankshaft throw to the bottom of its stroke, then push the piston all the way down until the rod bearing seats on the crankshaft journal. Install the rod cap, then tighten the nuts to 45-50 foot-pounds torque.

On a 302 or 332 engine, install the pal nuts and tighten them to 3-4 foot-pounds torque.

5. After the piston and connecting rod assemblies have been installed, check the side clearance between the connecting rods on each connecting rod crankshaft journal (Fig. 66).

6. Install the oil pan. Install the cylinder heads, exhaust manifolds, the push rods, and the valve rocker arm shaft assemblies. Make a preliminary valve lash adjustment. Install the intake manifold and carburetor as an assembly. Install the air cleaner. Fill and bleed the cooling system. Fill the crankcase with the proper grade and quantity of engine oil.

7. Start the engine and operate it for a minimum of 30 minutes at approximately 1200 rpm. With the engine temperature stabilized, check the valve lash with the engine idling and adjust it if necessary. Check for oil and coolant leaks. Install the valve rocker arm covers.

## 8 MAIN AND CONNECTING ROD BEARING REPLACEMENT

The main and connecting rod bearing inserts are selective fit and do not require reaming to size upon installation. **Do not file or lap bearing caps or use shims to obtain the proper bearing clearance.**

Selective fit bearings are available for service in standard sizes only. Standard bearings are divided into two sizes and are identified by a daub of red or blue paint. **Red marked bearings increase the clearance; blue marked bearings decrease the clearance.** Undersize bearings, which are not selective fit, are available for use on journals that have been refinished. Usually, bearing journals wear

ence may result, causing an early failure. It is not recommended that bearings be fitted to a journal which exceeds the maximum out-of-round specification. When replacing standard bearings with new bearings, it is good practice to first try to obtain the proper clearance with two blue bearing halves.

Do not get dirt or other foreign matter under the inserts. In time the dirt may distort the bearing and cause bearing failure.

### MAIN BEARING REPLACEMENT

The following procedure is for the engine installed in the chassis. If the

PLACE PLASTIGAGE FULL WIDTH OF JOURNAL ABOUT ¼ INCH OFF CENTER



INSTALLING PLASTIGAGE

CHECK WIDTH OF PLASTIGAGE



MEASURING PLASTIGAGE

1031-A

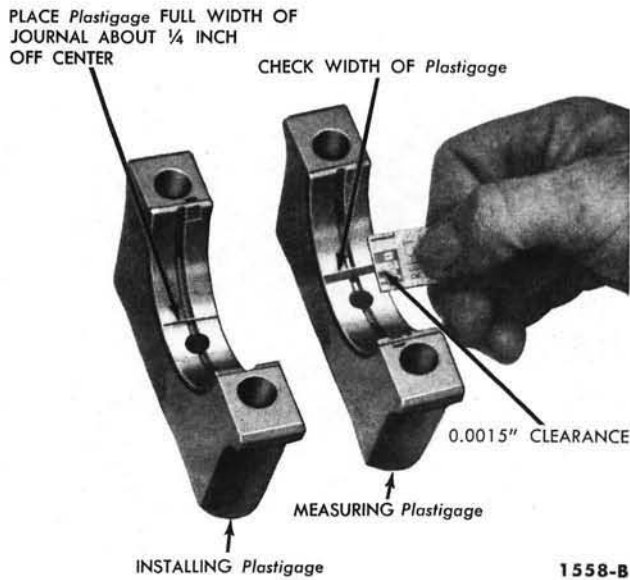
FIG. 67—Installing and Measuring Plastigage—Engine on Work Stand



**BUY IT NOW!**

**Click Here To Order**





**FIG. 68—Installing and Measuring Plastigage—  
Engine in Chassis**

engine is on a work stand, omit step 1 and follow steps 2-5. In step 4, if the engine is on a work stand it is not necessary to support the crankshaft because the engine will be inverted. Also in step 4 place the Plastigage on the crankshaft journal (Fig. 67) instead of on the bearing surface if the engine is on a work stand.

1. Drain the crankcase. Remove the oil level dipstick, the oil pan, the oil pump and pick-up tube assembly, and the intermediate drive shaft.

2. Replace one bearing at a time, leaving the other bearings securely fastened. Remove the main bearing cap to which new bearings are to be installed. Insert the upper bearing removal tool (tool 6331) in the oil hole in the crankshaft. Rotate the crankshaft in the direction of engine rotation to force the bearing out of the block.

3. To install the upper main bearing, place the plain end of the bearing over the shaft on the locking tang side of the block. Using tool 6331, rotate the crankshaft in the opposite direction of engine rotation until the bearing seats itself. Remove the tool. Replace the cap bearing. Clean the crankshaft journal and bearings.

on the bearing surface the full width of the bearing cap and about 1/4 inch off center (Fig. 68). Install the cap and tighten the bolts to specifications. **Do not turn the crankshaft while the Plastigage is in place.** Remove the cap, then using the Plastigage scale, check the width of the Plastigage at the widest point in order to get minimum clearance. Check the Plastigage at the narrowest point in order to get the maximum clearance. The difference between the two readings is the taper.

If the clearance is less than the specified limits, try two red bearing halves or a combination of red and blue depending upon the condition. If the standard bearings do not bring the clearance within the desired limits, refinish the crankshaft journal, then install undersize bearings.

5. After the bearing has been checked and found to be satisfactory, apply a light coat of engine oil to the journal and bearings, then install the bearing cap. Tighten the cap bolts to specifications.

6. If the rear main bearing is replaced, replace the retainer seal (292 engine) or lower seal in the cap (302 or 332 engine) and the side seals. The upper oil seal (in the block) can be replaced with the crankshaft seal.

7. Install the intermediate drive shaft, oil pump, and inlet tube and pick-up tube assembly. Install the oil pan. Drain the crankcase.

8. Operate the engine at fast idle and check for oil pressure and oil leaks.

### CONNECTING ROD BEARING REPLACEMENT

1. Drain the crankcase. Remove the oil level dip stick, the oil pan, the oil pump and pick-up tube assembly, and the intermediate drive shaft. Remove the cap from the connecting rod to which new bearings are to be installed and remove the bearing insert. Push the piston up in the cylinder, then remove the bearing insert from the connecting rod. Clean the crankshaft journals, the cap, and the upper half of the bearing bore.

2. Install the new bearings in the connecting rod and cap. Pull the connecting rod assembly down firmly on the crankshaft journal. Place a piece of Plastigage on the lower bearing surface, the full width of the cap and about 1/4 inch off center. Install the cap and tighten the connecting rod nuts to 45-50 foot-pounds torque. **Do not turn the crankshaft while the Plastigage is in place.**

3. Remove the cap, then using the Plastigage scale check the width of the Plastigage at the widest point in order to get the minimum clearance. Check the Plastigage at the narrowest point in order to get the maximum clearance. The difference between the two readings is the taper.

If the clearance is less than the specified limits, try two red bearing halves or a combination of red and blue depending upon the condition. If the standard bearings do not bring the clearance within the desired limits, refinish the crankshaft journal, then install undersize bearings.

After the bearing clearance has been checked and found to be satisfactory, apply a light coat of engine oil to the journal and bearings, then install the connecting rod cap. Tighten the nuts to 45-50 foot-pounds torque.

4. Repeat the procedure for the remaining connecting rods that require new bearings.

5. After all the bearings that required replacement have been replaced, install the intermediate drive shaft, oil pump, and inlet tube and screen assembly. Install the oil pan. Fill the crankcase.

6. Operate the engine at fast idle and check for oil pressure and oil leaks.

100% SATISFACTION GUARANTEED

**BUY IT NOW!**

Click Here To Order

PayPal American Express Discover Novus MasterCard VISA

## 9 OIL PAN, OIL PUMP, AND OIL FILTER

### OIL PAN

#### REMOVAL

1. Drain the oil from the crankcase. Remove the oil level dip stick.

On a 302 or 332 engine, remove the oil level dip stick tube.

On a truck with an automatic transmission, remove the converter housing dust cover.

On a C-series truck, crank the engine until No. 1 piston is on T.D.C.

2. Disconnect the oil pump inlet tube at the oil pump. Remove the "O" ring seal from the pump end of the tube. Remove the oil pan retaining screws and nuts, then remove the oil pan.

3. Remove the nut securing the inlet tube to the oil pan, then remove the oil pump screen and tube assembly from the oil pan.

#### INSTALLATION

1. Make sure the gasket surfaces of the oil pan and block are clean and free from burrs.

2. Fasten the oil pump screen to the cover and tube assembly with the screen retainer. Insert the tube through the hole in the side of the oil pan from the inside of the pan. Coat the inlet tube to the oil pan nut with oil resistant sealer, then install a new washer and the nut. Do not tighten the nut at this time.

3. Coat the cylinder block oil pan gasket surface with oil resistant sealer. Position a new gasket on the oil pan, hold the pan in place against the block, and install two of the retaining screws on each side of the pan. Install the remaining screws, and tighten them from the center outward, to 12-15 foot-pounds torque.

On a truck with automatic transmission, install the converter housing dust cover.

On a 302 or 332 engine, install the oil level dip stick tube and secure the retaining tab to the exhaust manifold.

4. Install a new "O" ring seal on the pump end of the tube, then install the tube and seal in the pump. Be careful not to damage the "O" ring seal. Tighten the jam nut at the oil

### OIL PUMP

The oil pump is shown in Fig. 69.

#### REMOVAL

1. Disconnect the oil inlet tube at the pump and remove the "O" ring seal. Loosen the tube at the pan.

2. Remove the oil pump to block retaining screws, then remove the pump, intermediate shaft, and gasket.

#### DISASSEMBLY

1. Remove the cover retaining screws, then remove the cover and "O" ring seal. Remove the inner rotor and shaft, and the outer race.

2. Remove the oil pressure relief valve chamber plug, gasket, spring, and plunger.

#### ASSEMBLY

1. Oil all parts thoroughly.

2. Install the oil pressure relief valve plunger, spring, gasket, and plug. Install the outer race, and the inner rotor and shaft assembly. The inner rotor and shaft, and the outer race are serviced as an assembly. One part should not be replaced without replacing the other.

3. Install the "O" ring seal in the groove on the pump body, and install the cover. Tighten the cover retaining screws to 12-15 foot-pounds torque.

### INSTALLATION

1. Install a new "O" ring seal on the pump end of the tube, then install the tube and seal in the pump. Be careful not to damage the "O" ring seal.

2. Insert the intermediate shaft into the oil pump.

3. Position a new gasket on the pump housing and install the pump and shaft as an assembly. Do not attempt to force the pump into position if it will not seat readily. The intermediate shaft hex may be misaligned with the distributor shaft. To align, rotate the intermediate shaft into a new position. Tighten the pump retaining screws to 12-15 foot-pounds torque.

4. Tighten the jam nut at the pump to 10-12 foot-pounds torque and the nut at the oil pan to 28-32 foot-pounds torque. Do not overtighten the inlet tube nuts.

### OIL FILTER REPLACEMENT

The oil filter assembly is shown in Fig. 70.

1. Place a drip pan under the filter. Loosen the filter center bolt, then remove the filter assembly and gasket.

2. Remove the filter element, neoprene gasket, spring, and seat.

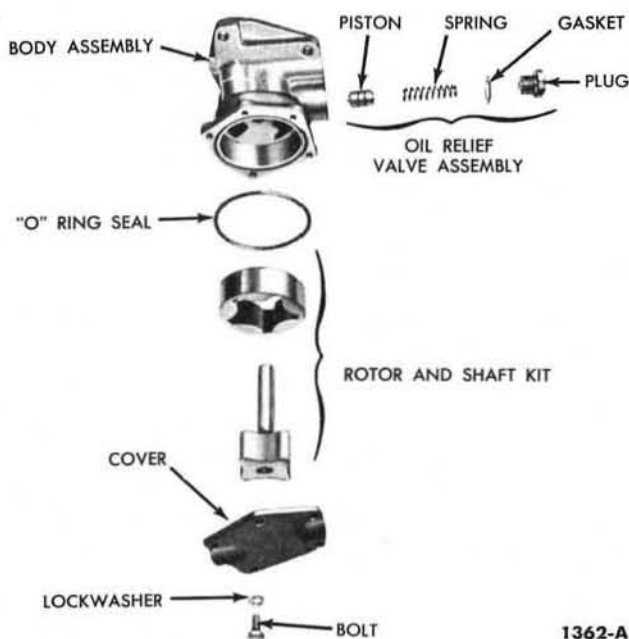


FIG. 69—Oil Pump Assembly

1362-A

**100% SATISFACTION GUARANTEED**

**BUY IT NOW!**

**Click Here To Order**

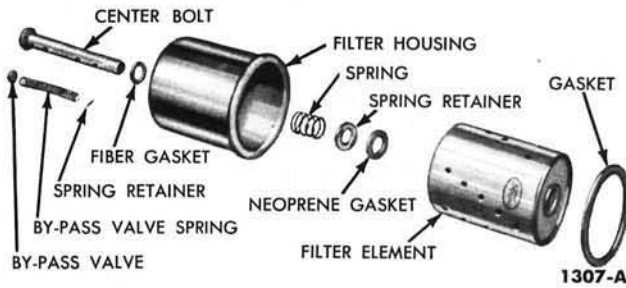


FIG. 70—Oil Filter Assembly

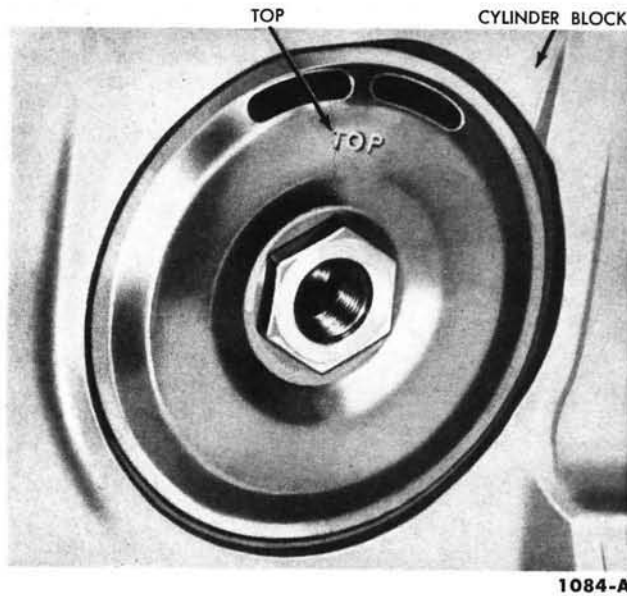


FIG. 71—Anti-Drain Back Diaphragm Position

Remove the center bolt from the container and the fiber gasket from the bolt. Discard the filter element and all gaskets. Wash all parts in solvent. Make sure all the openings in the center bolt are clean.

3. Install a new fiber gasket on the center bolt, then place the bolt through the filter container. Install the spring and spring seat assembly on the bolt, making sure the seat tangs are engaged in the spring. Install a new neoprene gasket and a new filter element over the center bolt.

4. Check to see if the two elongated holes in the oil filter anti-drain back diaphragm are in the up position (Fig. 71). Clean the cylinder block filter recess, then install a new gasket. Place the filter assembly in position, and thread the center bolt into the adapter finger tight. Rotate the filter slightly, in each direction, to make sure the gasket is seated evenly. Tighten the center bolt to 20-25 foot-pounds torque. **Do not overtighten the center bolt.**

5. Refill the crankcase with oil if necessary, then operate the engine at fast idle, and check for leaks. If oil leaks are evident, perform the necessary repairs to correct the leakage.

## 10 EXHAUST SYSTEM

### INLET PIPE AND MUFFLER REPLACEMENT—CONVENTIONAL-TYPE EXHAUST MANIFOLDS

The muffler and inlet pipe assembly is used in production only. A separate muffler and inlet pipe are used for service replacement.

1. Loosen all the outlet pipe clamp nuts. Slide the outlet pipe to the right to move the inlet pipe to the left.

on the exhaust manifold using a new gasket. Install the retaining nuts, then tighten the nuts to 23-28 foot-pounds torque. Place the muffler clamp on the inlet pipe, then position the muffler clamp on the inlet pipe. Install and tighten the clamp. Slide the outlet pipe into the muffler, and tighten the outlet pipe clamps.

### INLET PIPE REPLACEMENT—RAM'S HORN-TYPE EXHAUST MANIFOLDS

The left inlet pipe is serviced as a separate part. When service is required on the right pipe for the first time, the muffler must also be re-

placed. The factory installation of the right inlet pipe and muffler is a one piece assembly.

#### LEFT INLET PIPE

Loosen the U-bolt clamp that holds the left and right inlet pipes together. At the left exhaust manifold flange, disconnect the inlet pipe from the flange, then remove the inlet pipe and gasket.

Position one end of the left inlet pipe in the right inlet pipe, and connect the pipe to the exhaust manifold flange. Tighten the flange nuts to 23-28 foot-pounds torque. Tighten the U-bolt clamp.

**100% SATISFACTION GUARANTEED**

**BUY IT NOW!**

**Click Here To Order**

2. Remove a new service inlet pipe.

PayPal   American Express   Discover   MasterCard   VISA

**RIGHT INLET PIPE**

The procedure for the replacement of the right inlet pipe only, where the muffler has already been replaced, is as follows:

Loosen the U-bolt clamp that holds the left and right inlet pipes together. Loosen the muffler and outlet pipe clamps and support bracket. Slide the muffler and outlet pipe away from the inlet pipe. Disconnect the inlet pipe from the exhaust manifold flange, then remove the inlet pipe and gasket.

Position one end of the inlet pipe over the open end of the left inlet pipe. Attach the inlet pipe flange and a new gasket to the exhaust manifold flange. Tighten the manifold flange

bolts finger tight. Slide the muffler and outlet pipe forward and over the open end of the inlet pipe. Tighten the exhaust manifold flange nuts to 23-28 foot-pounds torque. Tighten the U-bolt clamp, then tighten the muffler and outlet pipe clamps and supports.

**MUFFLER REPLACEMENT—  
RAM'S HORN-TYPE EXHAUST  
MANIFOLDS**

Loosen the muffler pipe clamp, and slide the clamp away from the muffler. Cut the muffler inlet pipe with a hacksaw. Make the cut as close to the muffler as possible. Loosen all outlet pipe support clamps, then slide the outlet pipe to the rear. Pull the muf-

fler off the outlet pipe.

Install the clamps on the inlet pipe and position a new service muffler on the inlet pipe. Position the outlet pipe on the muffler. Tighten the inlet and outlet pipe to muffler clamps. Tighten the outlet pipe support clamps.

**OUTLET PIPE REPLACEMENT**

Loosen the outlet pipe clamp at the muffler. Remove the outlet pipe support clamps, then pull the outlet pipe off the muffler.

Position the muffler clamp on the new outlet pipe, then slide the pipe on the muffler. Install, but do not tighten, the support clamps. Tighten the outlet pipe to muffler clamp, then tighten the support clamps.

**SATISFACTION  
100%  
GUARANTEED**

**BUY IT NOW!**

**Click Here To Order**

PayPal American Express Discover MasterCard VISA

## PART

## 1-4

## SUPER DUTY V-8 ENGINES

Section	Page	Section	Page
1 Description.....	1-73	3 Engine Supports.....	1-83
2 Engine Removal and Installation.....	1-80	4 Manifolds, Cylinder Heads, and Valves.....	1-84
		5 Crankshaft Damper, Cylinder Front Cover, and Timing Gears.....	1-88
		6 Camshaft, Bearings and Tappets.....	1-91
		7 Flywheel, Crankshaft, Connecting Rods, and Pistons.....	1-92
		8 Main and Connecting Rod Bearing Replacement.....	1-97
		9 Oil Pan and Pump, Oil Filter, and Oil Cooler..	1-99
		10 Exhaust System.....	1-100

The super duty V-8 engines (401, 477, and 534 cubic inch displacement) will be referred to as SD V-8

engines.

The procedures are for the engine installed in the chassis unless other-

wise noted. Cleaning, inspection, repair, and overhaul procedures are covered in Part 1-1.

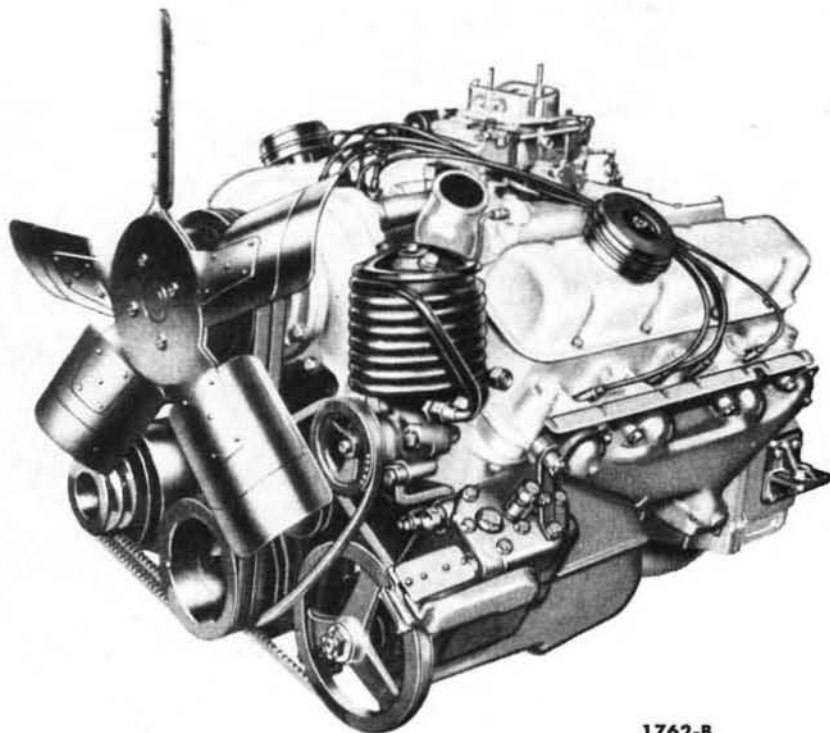
## 1 DESCRIPTION

All SD V-8 engines (Figs. 1 and 2) have the same basic design. The differences between the engine models and their application are listed in Table 1.

### MANIFOLDS

The intake manifold is water heated to assist in vaporizing the incoming fuel charge. It has two separate coolant passages, two thermostats, an air vent valve, and a coolant by-pass passage. The intake manifold has one fuel inlet into each cylinder head. The right barrels of the carburetor feed Nos. 1, 2, 3, and 4 cylinders and the left barrels feed Nos. 5, 6, 7, and 8 cylinders.

The fuel induction system is shown in Fig. 3.



1762-B

FIG. 1—Super Duty V-8 Engine—Typical

TABLE 1—Engine Model Application

Patent Plate Engine Code	Pre-fix	Piston Displacement	Bore	Stroke	Compression Ratio	Car-buretor	Governor	Distrib-utor	Truck Model Application
	EDL	401	4.125	3.75	7.5:1	4-Barrel	Mechanical	Centrifugal	F-C-T-850 and 950
					7.5:1	4-Barrel	Mechanical	Centrifugal	F-C-1000; T-850 and 950*
					7.5:1	4-Barrel	Mechanical	Centrifugal	F-C-1100; T-850 and 950*

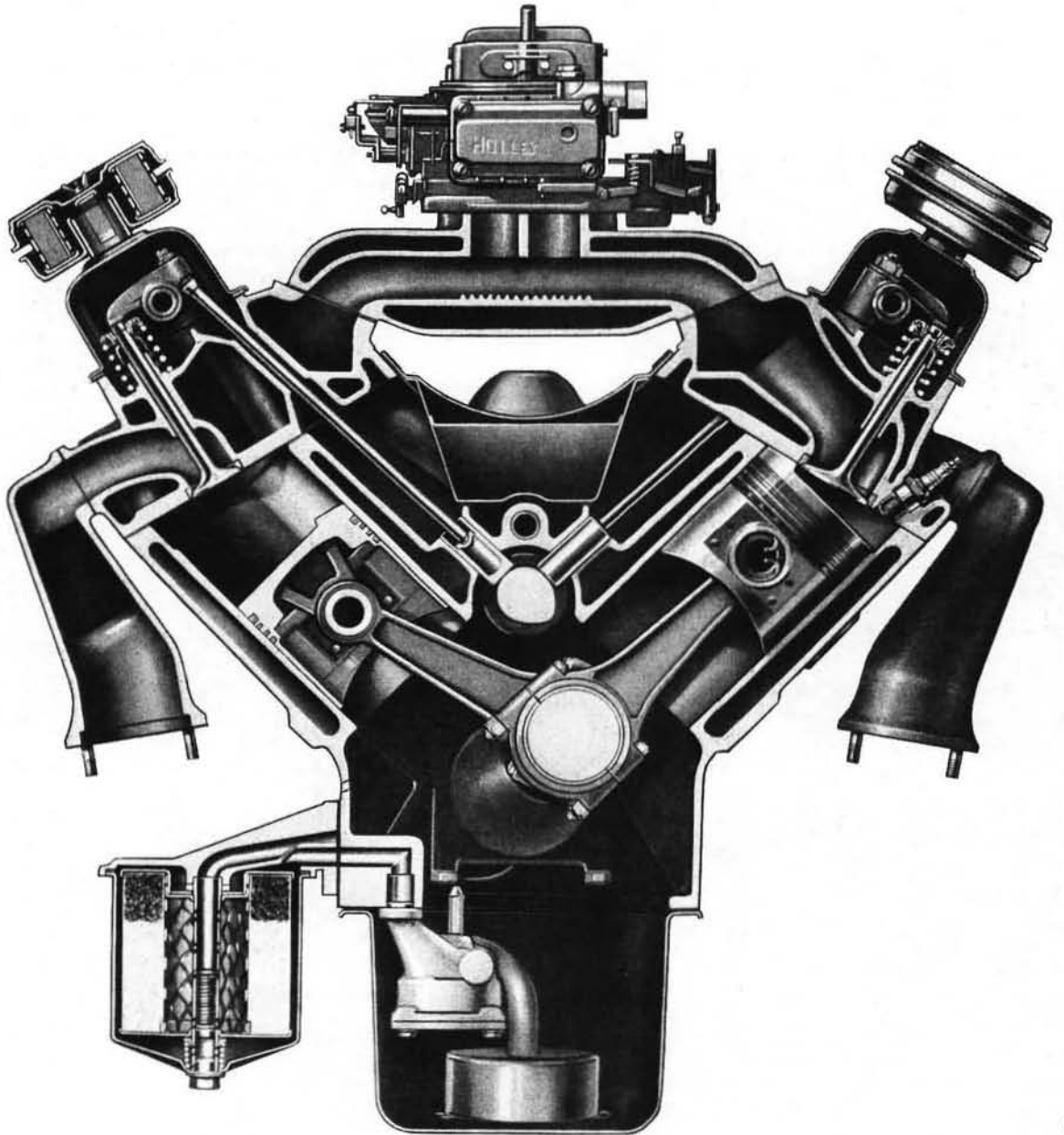


**BUY IT NOW!**

Click Here To Order

\*R





1686-B

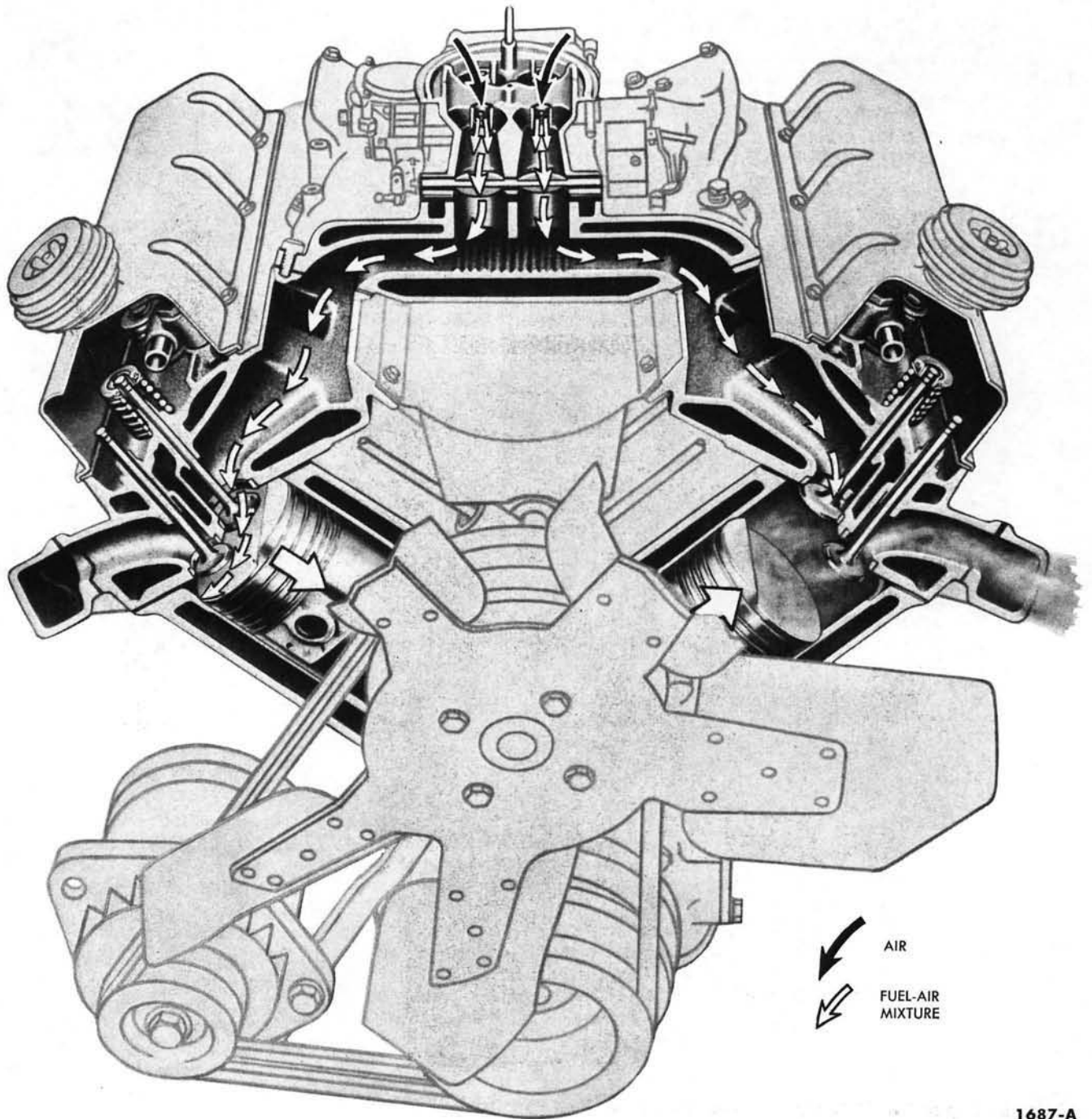
FIG. 2—Super Duty V-8 Engine—Sectional View

**100% SATISFACTION GUARANTEED**

**BUY IT NOW!**

**Click Here To Order** 



1687-A

FIG. 1 Fuel Induction System

**100% SATISFACTION GUARANTEED**

**BUY IT NOW!**

**Click Here To Order**

PayPal    American Express    Discover    MasterCard    VISA

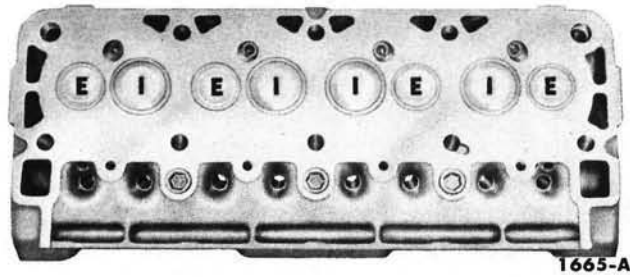


FIG. 4—Valve Port Arrangement

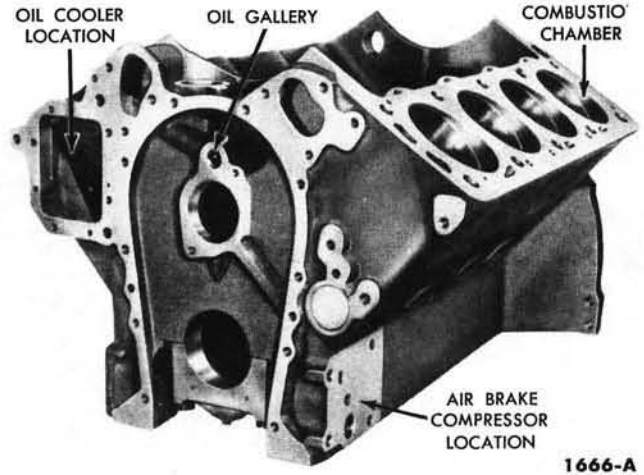


FIG. 5—Cylinder Block

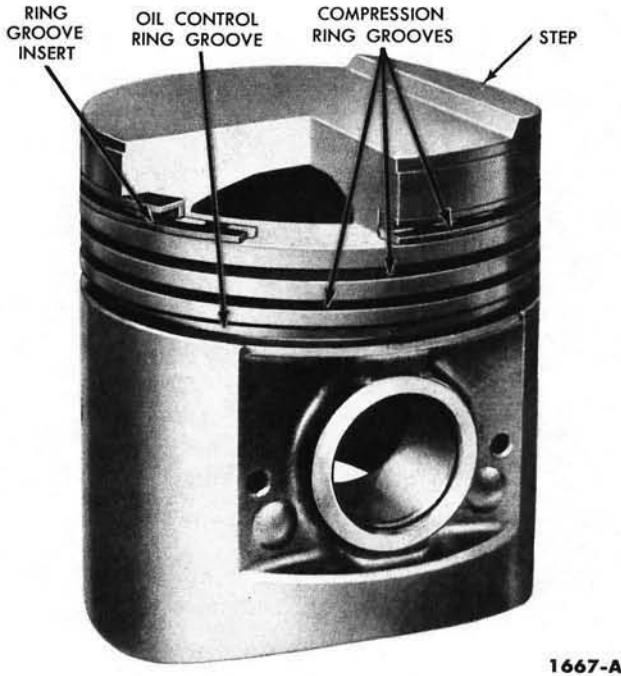


FIG. 6—Piston

**CYLINDER HEADS**

The cylinder head assemblies contain the fuel intake passages, the valves, and the valve rocker arm shaft assemblies. Valve guides are an integral part of the head. The intake and exhaust valve seats are the insert-type. Both the intake and exhaust valves are the rotating-type which rotate each time the valve opens and closes. Lubrication of the valve stems is controlled by umbrella-type valve stem seals which fit over the top of the valve stems. Valve springs have coil spacing which provides positive action at high rpm.

equally around each cylinder. Five of the ten cylinder head bolts also serve as pedestals for the valve rocker arm shaft. The other five bolts are located on the outside edge of the cylinder head.

The spark plugs are located above the exhaust manifolds for greater accessibility. The spark plug bosses are water jacketed.

**CYLINDER BLOCK**

The oil pump is mounted inside the oil pan at the front. The distributor is located at the front of the engine and drives the oil pump through an intermediate drive shaft. An internal oil cooler is located at the front on the right side of the block and the air brake compressor is mounted on the left side of the block.

The combustion chambers are located in the cylinder block (Fig. 5).

This reduces the intense combustion temperatures in the head area and permits the entire face of the cylinder head to be flat-machined for positive mating of the head to the block. The combustion chambers are formed by casting the top of each cylinder bank on a 13° angle with the piston.

The camshaft is supported by five insert-type main bearings pressed into the block. It is driven by a gear in mesh with a gear on the crankshaft. Camshaft end play is controlled by a thrust plate bolted to the front of the block. The distributor is driven by a gear at the front of the camshaft and the mechanical governor is driven by a gear at the rear of the camshaft. The tappets are the solid steel-type and the push rods are tubular steel.

The forged-steel crankshaft is supported by five insert-type main bearings. Crankshaft end thrust is controlled by the flanges of the No. 3 main bearing. Oil slingers are provided to prevent leakage by directing the oil away from the front and rear oil seals.

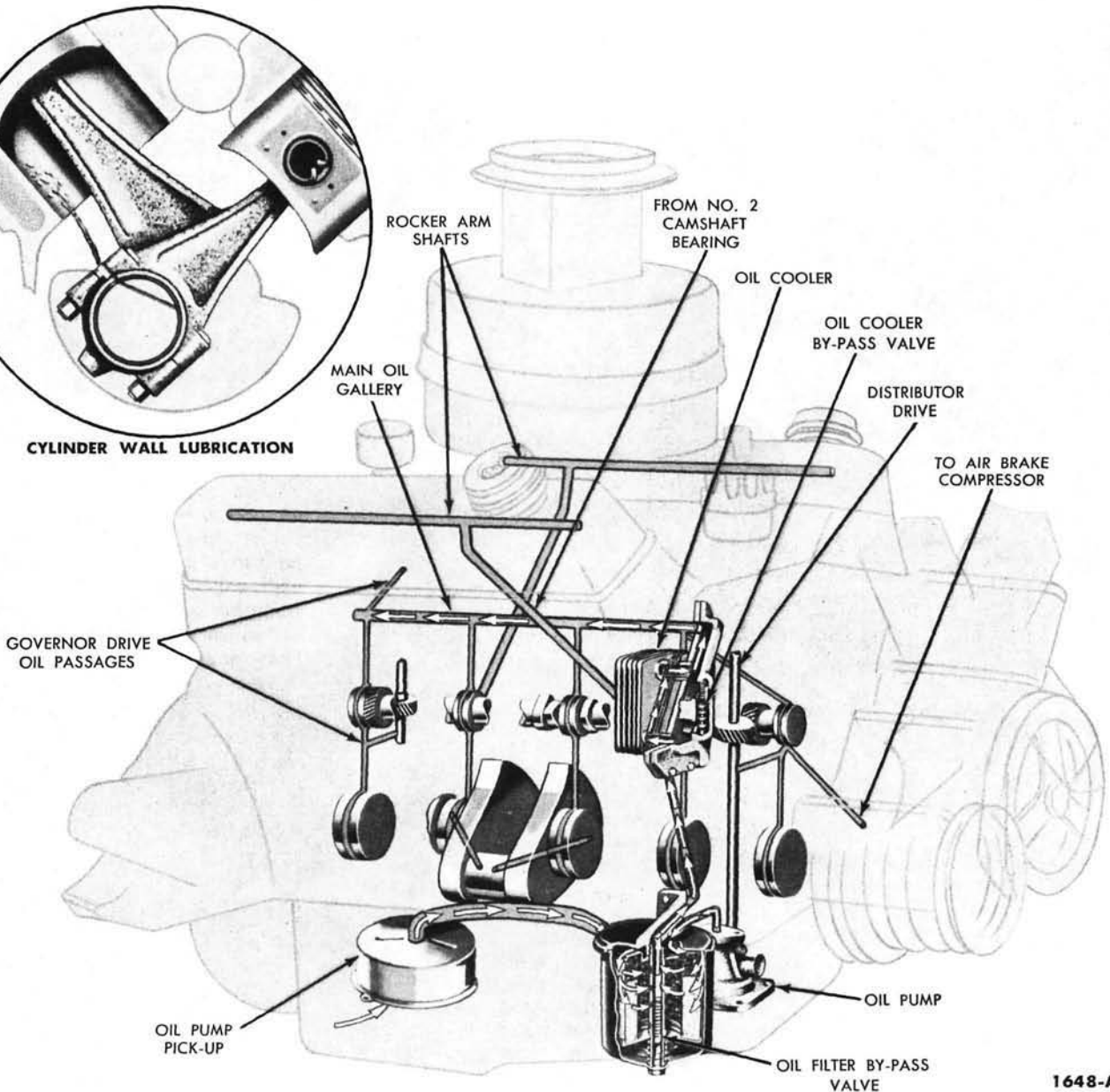
The aluminum alloy, four-ring pistons (Fig. 6) are of the autothermic design. Autothermic design means that steel struts are placed at the piston pin bosses to provide controlled piston expansion. This allows closer initial piston fits without binding or excessive friction.

A step is cast on the top surface of the piston which slants upward then tapers down to the edge. As the piston reaches the top of the compression stroke, the step drives into the narrowing wedge of the combustion chambers. The forced pressure

**100% SATISFACTION GUARANTEED**

**BUY IT NOW!**

**Click Here To Order**



1648-A

FIG. 7—Lubrication System

jets the fuel-air mixture across the spark plug electrode for better combustion.

The piston has three compression rings. The top ring is chromium plated and the second and third rings are oxide coated. The top ring groove has an interlocking cast iron insert which encloses the ring on all three sides.

**LUBRICATION SYSTEM**

Oil from the oil pan sump, located in the front of the oil pan, is forced through the pressure lubrication system (Fig. 7) by a rotor-type oil pump. The oil pump, mounted in the front of the crankcase, is driven by the distributor through an intermediate shaft. A spring loaded relief valve in the pump limits the maximum pressure of the system. Oil returning to the pump is directed back to the intake side of the pump. Oil discharged by the pump

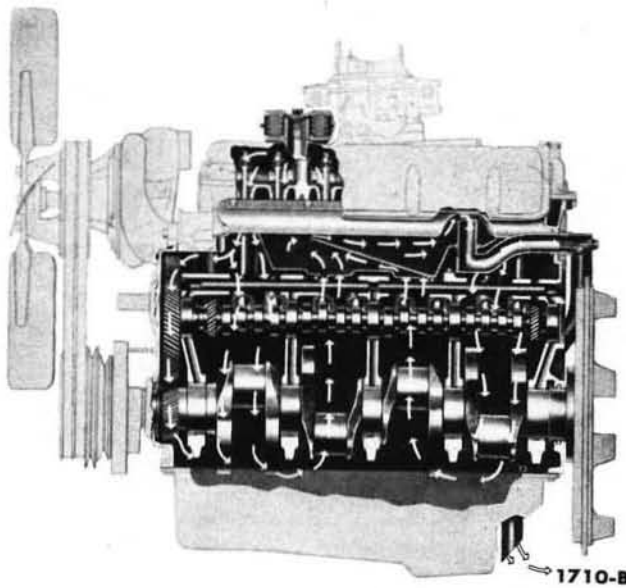
passes through a full flow-type filter before it enters the engine. The filter is mounted in a vertical position at the lower right front of the engine. A built in by-pass provides oil to the engine in case the filter element becomes clogged. The by-pass is located in the hollow center bolt and consists of a spring loaded valve. When the filter element is clean and oil will flow through it, the pressure difference between the inner and outer faces of the valve is not great enough to overcome the spring pressure behind the valve. Therefore, no oil flows through the

**100% SATISFACTION GUARANTEED**

**BUY IT NOW!**

**Click Here To Order**

PayPal   American Express   Discover   MasterCard   VISA



**FIG. 8—Crankcase Ventilation**

by-pass. When the element is dirty and will not permit a sufficient flow of oil, the pressure acting on the inner face of the valve drops. If the pressure difference between the valve faces is great enough to overcome spring pressure, the valve will open. Oil then by-passes the element, maintaining an emergency supply of oil to the engine.

The oil from the filter flows through a passage in the block to the oil cooler located in the water passage at the front of the block adjacent to the No. 1 cylinder. A spring loaded relief valve in the oil cooler cover opens at approximately 15 psi pressure differential. In the event of any obstruction and/or malfunction of the oil cooler, the engine oil will by-pass the oil cooler, maintaining adequate engine lubrication.

From the oil cooler, the oil flows into the main oil gallery located in the center of the valve chamber floor. The oil gallery supplies oil to each camshaft bearing through drilled passages in the block. Passages are drilled from each camshaft bearing to each main bearing. Number 1 camshaft bearing feeds No. 1 main bearing, No. 2 camshaft bearing feeds

#### Main Bearing

No. 1	Serves
No. 2	Serves
No. 3	Serves
No. 4	Serves
No. 5	Serves

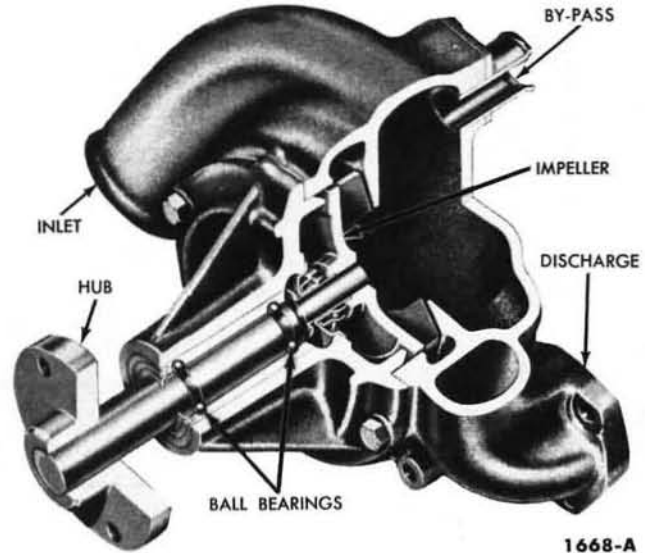
#### Connecting Rod Bearing

No. 1
Nos. 2 and 5
Nos. 3 and 6
Nos. 4 and 7
No. 8

A small groove is located in the connecting rod at the mating face where the cap contacts the connecting rod. This groove is used as an oil squirt hole for cylinder wall lubrication. Oil from the connecting rod squirt hole lubricates the opposite cylinder wall. For example, the No. 1 connecting rod lubricates No. 5 cylinder wall, etc. As the crankshaft turns, the hole in the connecting rod bearing aligns with the hole in the journal causing a direct squirt of oil onto the cylinder wall.

A passage is drilled from the No. 1 camshaft bearing to lubricate the air brake compressor. Oil from the compressor is returned directly to the oil pan through a return hole in the side of the block. The No. 1 camshaft bearing also lubricates the timing gears.

A passage is drilled from the No. 2 camshaft bearing web to the No. 2 valve rocker shaft support to lubricate the right valve rocker arm shaft assembly. The left valve rocker arm shaft assembly is similarly lubricated from the No. 4 camshaft bearing web and the No. 4 rocker arm shaft support. The oil enters the valve rocker arms through the valve rocker arm shaft supports. The oil from the sup-



**FIG. 9—Water Pump**

ports flows through drilled holes in each rocker arm to lubricate each rocker arm bushing and the valve and ball joint ends of the rocker arm. The excess oil spirals down the rotating push rods and assists in lubricating the tappets and push rods. A baffle located under the valve rocker shaft assembly shields the valve stems from oil splash.

The governor, located at the rear center section of the engine, is lubricated from the rear of the main oil gallery. The oil pressure sending unit and the tachometer drive are attached to the governor.

The distributor drive is lubricated from a drilled passage from the No. 1 camshaft bearing web.

#### CRANKCASE VENTILATION

A crankcase ventilation tube is located at the rear of the engine. The forward motion of the truck causes a partial vacuum to be formed at the tube. This vacuum action causes air to be drawn through the engine from the ventilation filter located on each valve rocker arm cover (Fig. 8). The filter contains a replaceable paper element which filters the incoming air.

#### COOLING SYSTEM

The cooling system has three stages of operation. A thermostat is located at the rear and at the front of the intake manifold. The rear thermost (which opens first) allows coolant from the cylinder block to pass through the intake manifold and into the water pump for re-circulation.

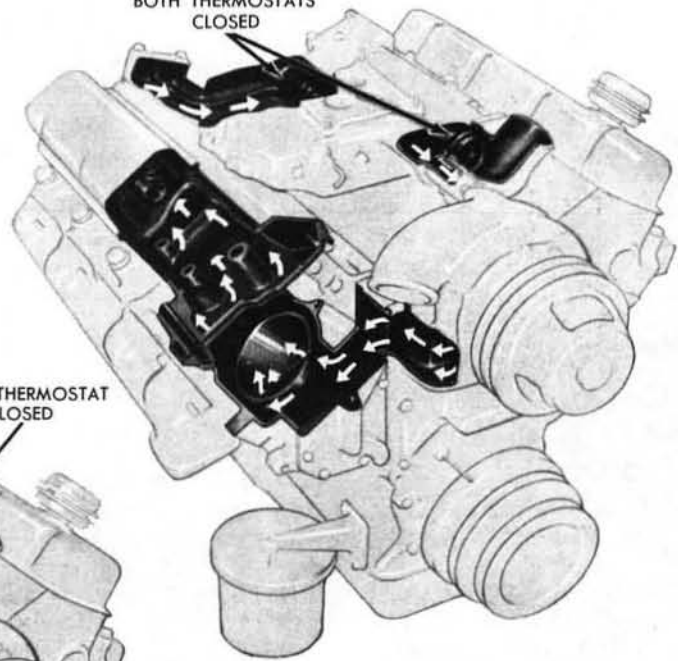
**100% SATISFACTION GUARANTEED**

**BUY IT NOW!**

**Click Here To Order**

FROM DEALERS TO THE CONSUMER YOU

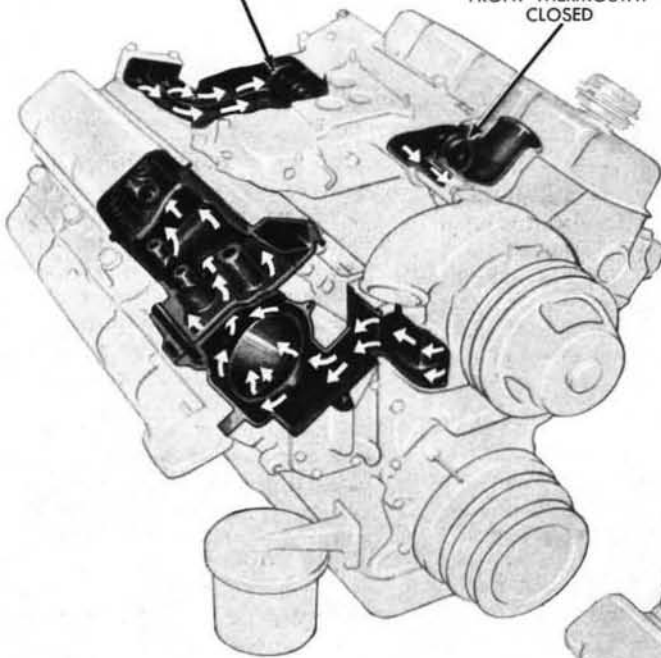
BOTH THERMOSTATS  
CLOSED



STAGE 1

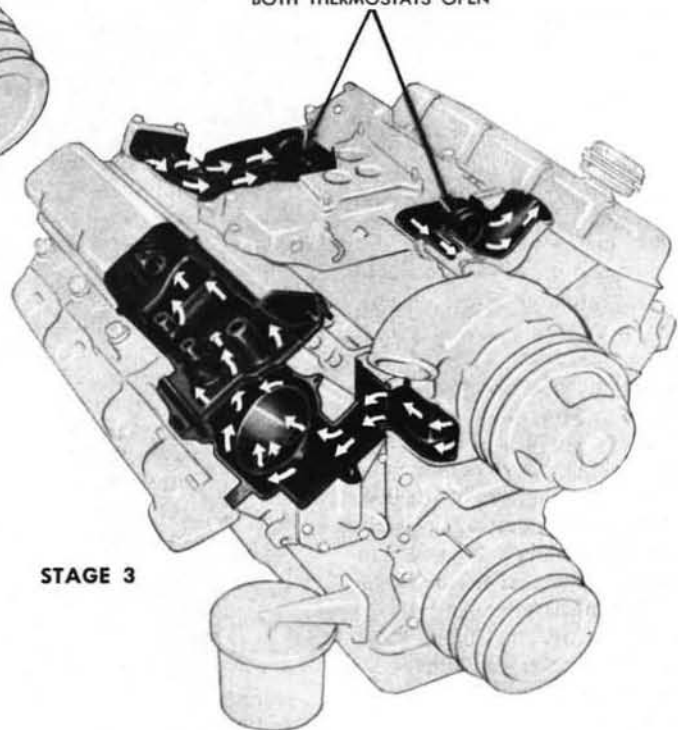
REAR THERMOSTAT  
OPEN

FRONT THERMOSTAT  
CLOSED



STAGE 2

BOTH THERMOSTATS OPEN



STAGE 3



**BUY IT NOW!**

[Click Here To Order](#)

FIG



The front thermostat (which opens last) allows the coolant to re-circulate through the radiator. An air vent line at the front of each cylinder head is connected to the intake manifold. This arrangement minimizes the possibility of hot spots due to air entrapment. An air vent valve is located at the left front of the intake manifold to bleed the system when it is being filled.

The water pump used (Fig. 9) is a high capacity vortex double discharge-type.

Coolant circulation will be referred

to as stage 1, stage 2, and stage 3 (Fig. 10).

In stage 1, both thermostats are closed. The coolant flows from the water pump into the front of each cylinder head and into the front of each side of the block. The coolant circulates through the cylinder heads and into the intake manifold through a connecting passage at the rear of the heads. From the intake manifold, the coolant is returned to the water pump for re-circulation via the coolant by-pass passage. With the rear thermostat closed, the coolant in the cylinder block can not flow into the

intake manifold and return to the water pump for recirculation.

In stage 2, the rear thermostat opens and the coolant in the cylinder block is free to flow through the intake manifold and into the water pump for re-circulation.

In stage 3, the front thermostat opens and the coolant is allowed to circulate through the radiator. Coolant flows from the radiator to the water pump and is circulated through the engine.

The entire system is pressurized to 7 psi by a pressure-type radiator cap.

## 2 ENGINE REMOVAL AND INSTALLATION

The procedures are separated according to truck body styles.

### F- AND T-SERIES

A typical engine installation is shown in Fig. 11.

#### REMOVAL

1. Remove the hood and the cross braces. Drain the cooling system and the crankcase. Disconnect the battery ground strap. Remove the carburetor air cleaner.

2. Remove the fan, radiator, and the fan shroud.

On a truck with conventional brakes, disconnect the vacuum assist brake line at the intake manifold.

On a truck with power steering, disconnect the power steering return line and the pump pressure line at the bracket on the frame left side member. Drain the oil into a suitable container. Disconnect the power steering return line at the pump reservoir and the pressure line at the pump housing.

On a truck with an air compressor, loosen the outlet line at the air compressor and allow the air to escape, then disconnect the line. Disconnect the air compressor governor line at the air compressor.

3. Disconnect the heater hose at the water pump and at the intake manifold, the primary wire at the coil, and the oil pressure and temperature sending unit wires at the sending units. Remove the wiring from the clip at the coil and intake manifold, then position

4. Disconnect the fuel filter inlet line at the flexible hose and remove the retaining clamp at the intake manifold. Disconnect the tachometer drive cable at the governor. Remove the accelerator retracting spring, and remove the accelerator rod retaining clip at the carburetor. Remove the hand throttle cable from the carburetor and position it on the dash panel. Disconnect the engine ground strap at the dash panel.

5. Disconnect the wiring harness at the alternator. Remove the oil filter. Remove the crankcase ventila-

tion tube. Disconnect the right and left muffler inlet pipes at the exhaust manifolds.

6. Place a jack under the front bumper at the right side and raise the right front of the truck. Remove the starter shield and starter, then lower the truck and remove the jack. Install the engine lifting eye bolts and sling (Fig. 12).

7. Remove the engine front mount to frame retaining bolts, nuts, and washers. Remove the flywheel housing dust cover. Position a jack under the transmission and remove the fly-

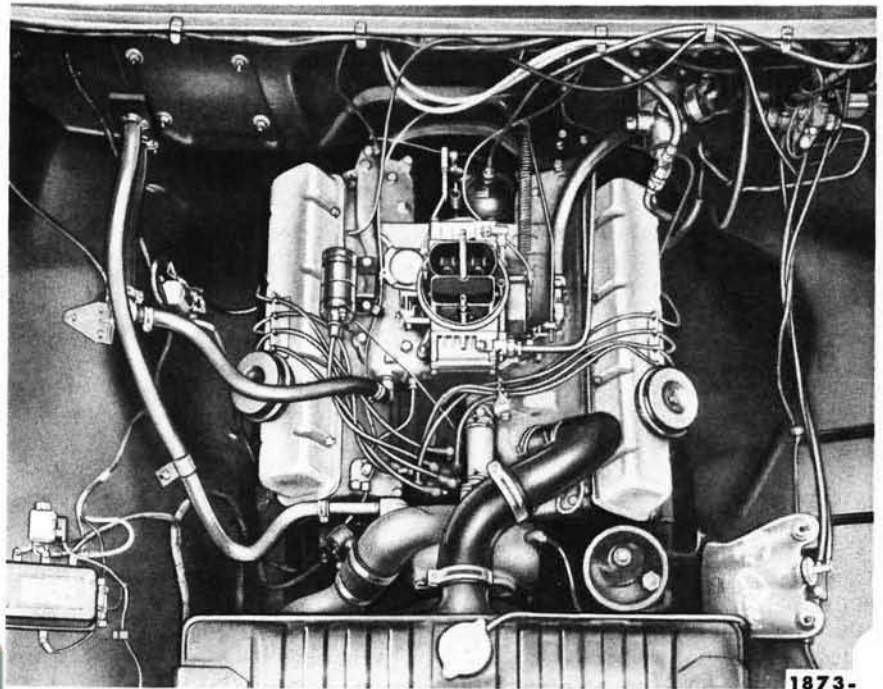


FIG. 11—Typical SD V-8 Engine Installation—T-Series Truck

**100% SATISFACTION GUARANTEED**

**BUY IT NOW!**

**Click Here To Order**

PayPal   American Express   Discover   MasterCard   VISA

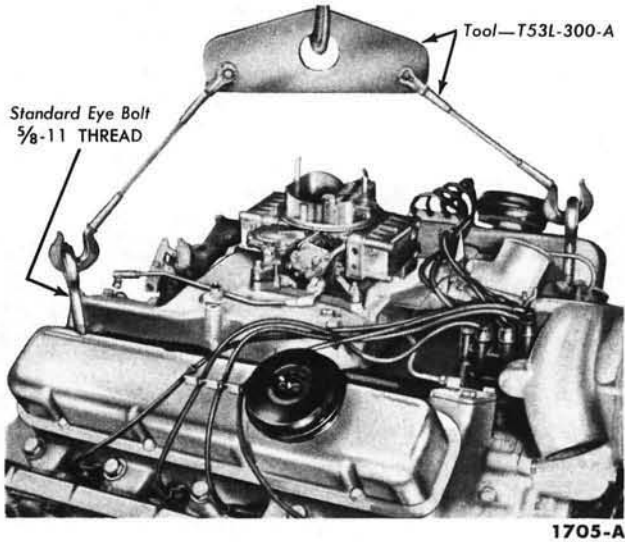


FIG. 12—Engine Lifting Sling

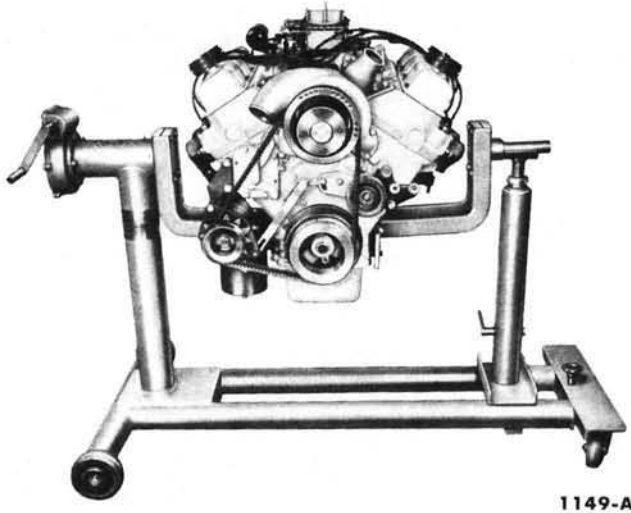


FIG. 13—Engine Work Stand

wheel to engine retaining bolts. Remove the engine from the chassis and install it on a work stand (Fig. 13).

#### INSTALLATION

1. Install guide pins in the two flywheel housing lower bolt holes in the engine. Place new muffler inlet pipe gaskets over the exhaust manifold studs. Attach the engine lifting eye bolts and sling (Fig. 12) and remove the engine from the work stand. Carefully lower the engine into the engine compartment. Make sure the exhaust

all the bolts to specifications. Remove the jack from the transmission. Install the flywheel housing dust cover. Install the engine front mount bolts, washers, and nuts, then tighten them to specifications. Install the oil filter. Connect the muffler inlet pipes.

3. Place a jack under the front bumper at the right side and raise the right front of the truck. Install the starter shield and starter, then lower the truck and remove the jack. Install the crankcase ventilation tube, securing the upper bracket to the flywheel housing and the lower bracket to the frame to engine ground strap) on the engine.

Remove the engine lifting eyes from the sling. Connect the ignition wires. On a truck with conventional steering, connect the vacuum assist

brake line at the intake manifold.

On a truck with an air compressor, connect the governor line and the outlet at the air compressor.

On a truck with power steering, connect the power steering return line to the pump reservoir and the pressure line at the pump housing. Connect the return line and pressure line to the bracket on the frame left side member.

5. Connect the engine ground strap, hand throttle cable, accelerator rod and retracting clip, and the accelerator return spring. Connect the fuel inlet line and connect the retaining clamp to the intake manifold. Position the wiring harness in the retaining clip at the left rear corner of the intake manifold.

6. Connect the alternator wires, the choke control cable, the tachometer drive cable, the oil pressure and engine temperature sending unit wires, and the oil pressure safety switch wires. Connect the heater return hose to the water pump and the heater inlet hose at the engine.

7. Position the fan shroud in the engine compartment, then install the radiator. Install the fan blade assembly, then install the fan shroud. Connect the radiator inlet and outlet hoses.

8. Connect the battery ground strap. Fill and bleed the cooling system. Fill the crankcase with the proper grade and quantity of engine oil.

On a truck with power steering, fill the power steering pump following the recommended procedure.

Run the engine at fast idle and check all gaskets and hose connections for leaks. Install the air cleaner. Install the cross braces and the hood.

#### C-SERIES

##### REMOVAL

1. Release the cab lock and tilt the cab forward. Drain the cooling system and the crankcase. Disconnect the battery ground cable at the battery. Remove the carburetor air cleaner.

2. Remove the oil level dip stick. Disconnect the radiator supply tank tube at the front thermostat housing. Remove the radiator supply tank bracket retaining bolts, nuts, and lockwashers. Disconnect the cab latch anti-rattle springs, then remove the bracket and tank assembly.

3. Disconnect the resistor wires at the coil. Disconnect the oil pressure and engine temperature wires at the sending units. Disconnect the choke

**100% SATISFACTION GUARANTEED**

**BUY IT NOW!**

**Click Here To Order**

PayPal American Express Discover/Novus MasterCard VISA

control cable at the carburetor. Disconnect the oil pressure safety switch wires at the switch. Disconnect the heater hoses at the engine and remove the hose retaining bracket from the intake manifold. Remove the heater return hose adapter from the water pump. Disconnect the radiator outlet hose at the water pump and slide the hose downward. Disconnect the wires at the alternator. Loosen the alternator mounting bolts and the adjusting arm bolts, then remove the two drive belts. Remove the oil filter. Remove the starter and starter shield and the crankcase ventilation tube.

4. Disconnect the hand throttle control cable and the accelerator cable at the carburetor. Remove the accelerator cable bracket and the accelerator return spring. Remove the bracket that secures the choke and throttle cables to the radiator bracket. Remove the accelerator cable retaining bracket from the radiator bracket and air deflector.

5. Disconnect the fuel line at the flex line, then remove the line. Disconnect the tachometer drive cable at the governor.

6. Remove the radiator inlet hose. Remove the fan assembly retaining bolts. Disconnect the radiator right and left support straps at the frame cross member and loosen the strap bolts at the radiator, then move the straps out of the way. Disconnect the radiator from the frame side rail. Remove the radiator drain valve, then remove the radiator and fan assembly.

On a truck with conventional brakes, disconnect the vacuum assist brake line at the intake manifold.

On a truck with power steering, disconnect the power steering return line at the pump reservoir and the pressure line at the pump housing. Drain the oil into a suitable container. Loosen the pump assembly and remove the drive belt.

On a truck with an air compressor, loosen the outlet line at the air compressor and allow the air to escape,

7. Install the engine lifting eye bolts and sling (Fig. 12). Disconnect the muffler inlet pipes at the exhaust manifold. Remove the oil pan. Position a floor jack under the transmission with no pressure applied. Remove the flywheel housing dust cover and the flywheel to engine bolts. Disconnect the parking brake clevis pin. Disconnect the engine front mount at the frame cross member. Raise the engine approximately one inch and support the transmission with the jack. Remove the engine from the chassis and install it on a work stand (Fig. 13).

#### INSTALLATION

1. Install guide pins in the flywheel housing two lower bolt holes in the engine block. Place a new gasket over the exhaust manifold studs. Attach the engine lifting eye bolts and sling (Fig. 12) and remove the engine from the work stand. Carefully lower the engine into the chassis. Make sure the exhaust manifolds are properly aligned with the muffler inlet pipes and the guide pins in the engine block engage the holes in the flywheel housing.

2. Install two flywheel housing to engine bolts and remove the guide pins. Install the remaining bolts, then tighten all the bolts to specifications. Install the engine front mount bolts, washers, and nuts, then tighten them to specifications. Remove the jack from the transmission. Install the flywheel housing dust cover and the parking brake clevis pin. Install the crankcase ventilation tube and the starter. (The engine ground strap is retained by the starter mounting at the starter shield bolt and one crankcase ventilation tube bolt is retained by one of the starter bolts). Install the oil pan and the oil filter. Remove the engine lifting eye bolts and sling.

3. Connect the fuel line to the flex line.

On a truck with conventional brakes, connect the vacuum assist brake line at the intake manifold.

On a truck with an air compressor, install the air compressor pulley and the drive belt. Adjust the belt tension, then tighten the idler pulley. Connect the air compressor governor line and outlet at the air compressor.

On a truck with power steering, install the drive belt. Adjust the belt tension, then tighten the pump assembly. Disconnect the power steering return line at the pump reservoir and the pressure line at the pump housing, and connect the lines at the bracket on the frame left side member.

4. Install the alternator drive belts. Adjust the tension of the belts, then tighten the alternator mounting bolts and the adjusting arm bolts. Connect the alternator wires. Connect the oil pressure safety switch wires, the choke control cable, and the oil pressure and engine temperature sending unit wires.

5. Install the radiator and shroud assembly in the chassis with the fan positioned in the shroud. Install the fan on the crankshaft damper. Connect the radiator outlet hose at the water pump and the radiator inlet hose at the intake manifold. Install the radiator drain cock. Apply sealer to the heater return hose adapter and install the adapter in the water pump. Connect the heater hose and install the retaining bracket on the intake manifold. Install the radiator supply tank and bracket (with the coil). The cab lock release spring bracket is retained by the radiator supply tank upper bolt. Connect the radiator supply tank tube to the front thermostat housing. Connect the cab latch anti-rattle springs. Connect the coil wires. Install the oil level dip stick.

6. Install the accelerator cable retaining bracket on the radiator bracket and air deflector. Install the bracket for the choke and throttle cable and tachometer wire on the radiator bracket. Install the accelerator cable bracket and the accelerator retracting spring. Connect the hand throttle control cable and the accelerator cable at the carburetor. Connect the tachometer drive cable.

7. Connect the battery ground strap. Fill and bleed the cooling system. Fill the crankcase with proper grade and quantity of engine oil.

On a truck with power steering, fill the power steering pump following the recommended procedure.

Run the engine at fast idle a check all gaskets and hose connections for leaks. Install the air cleaner. Lower and lock the cab.

**100% SATISFACTION GUARANTEED**

**BUY IT NOW!**

**Click Here To Order**

### 3 ENGINE SUPPORTS

#### ENGINE FRONT SUPPORT

The engine front support is shown in Fig. 14.

##### REMOVAL

Disconnect the alternator adjusting arm at the engine front support insulator and remove the air compressor idler pulley. Remove the front support insulators to front support bracket retaining nuts, lockwashers, and bolts. Position a jack and wood block under the oil pan and raise the engine slightly. Remove the upper and lower insulators.

##### INSTALLATION

Position the upper and lower insulators on the front support bracket. Install, but do not tighten, the front support insulator retaining bolts, lockwasher, and nuts. Lower the engine and remove the jack and wood block. Tighten the retaining bolts to specifications. Connect the alternator adjusting arm and install the air compressor idler pulley. Adjust the drive belts.

#### ENGINE REAR SUPPORTS

The engine rear support is shown in Fig. 15 or 16. The procedures

given apply to either a right or left installation.

##### REMOVAL

Remove the cotter pin from the engine rear mount bolt, then remove the mounting bolt, lower insulator, and spacer. Position a jack under the transmission and raise the rear of the engine. Remove the upper insulator (and shim on C-series).

##### INSTALLATION

Place the upper insulator (and shim on C-series) in position. Lower the rear of the engine and remove the jack. Align the rear of the engine with a drift pin and position the lower insulator and spacer. Install the engine mounting bolt and nut and tighten them to specifications. Install the cotter pin to the mounting bolt.

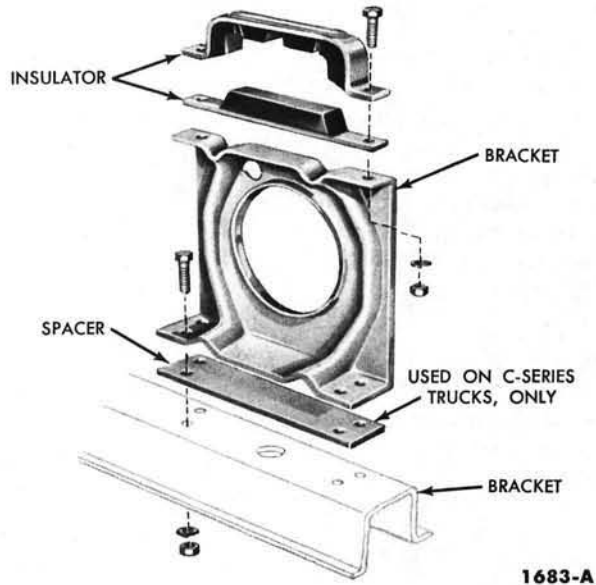


FIG. 14—Engine Front Support

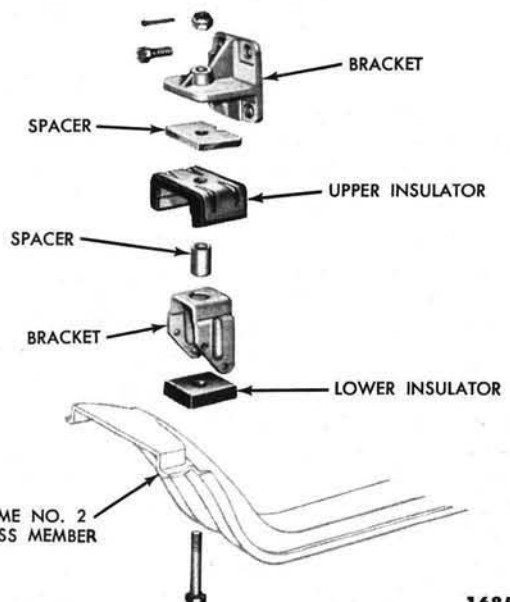
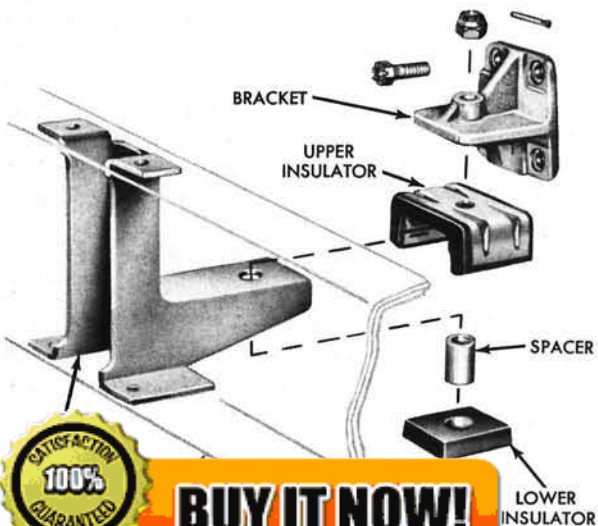


FIG. 16—Engine Rear Support—C-Series

**100% SATISFACTION GUARANTEED**

**BUY IT NOW!**

**Click Here To Order**

## 4 MANIFOLDS, CYLINDER HEADS, AND VALVES

### INTAKE MANIFOLD

The intake manifold assembly is shown in Fig. 17.

#### REMOVAL

1. Drain the radiator. Disconnect the radiator upper hose at the water pump. Remove the air cleaner. Disconnect the spark plug wires at the spark plugs and remove the wires from the bracket on the valve rocker arm covers. Disconnect the coil high tension lead at the coil. Remove the distributor cap and spark plug wire assembly. Remove the cooling system by-pass lines.

2. Disconnect the heater hose at the intake manifold and the radiator inlet and outlet hoses. Remove the coil bracket retaining bolts and washers and disconnect the wire at the temperature sending unit, then position the coil assembly and sending unit wire out of the way. Disconnect the choke control cable at the carburetor and the governor control rod at the governor.

On a truck with conventional brakes, disconnect the vacuum assist brake line at the intake manifold.

3. Disconnect the accelerator rod or cable at the accelerator assembly and the hand throttle control cable at the carburetor. Remove the accelerator retracting spring. Disconnect the carburetor fuel inlet line and remove the retaining clamps from the manifold. Slide the clamp on the intake manifold coolant outlet hose toward the water pump. Disconnect the tachometer cable at the governor and position the cable out of the way. Remove the intake manifold retain-

ing bolts, then remove the intake manifold assembly.

4. If it is necessary to remove the thermostats, remove them at this time. Remove the intake manifold coolant outlet hose elbow and gasket from the intake manifold and remove the front thermostat. Remove the rear thermostat housing cover and gasket, then remove the rear thermostat.

#### INSTALLATION

1. Clean the intake manifold gasket surfaces (including the front and rear thermostat housing gasket surface if the thermostats were removed).

If the thermostats were removed, position them in their respective housing. **Be sure the lower temperature thermostat is installed in the rear of the manifold and the higher temperature thermostat is installed in the front of the manifold.** Apply sealer to the thermostat housing gaskets and position them on the intake manifold. Install the intake manifold coolant outlet elbow and the rear thermostat housing cover.

2. Apply sealer to the intake manifold gaskets and position them on the cylinder heads. Position the intake manifold assembly on the cylinder heads. Install the intake manifold bolts and lockwashers, then tighten the bolts to 23-28 foot-pounds torque. Connect the carburetor inlet line and retaining clamps. Install the accelerator retracting spring. Connect the hand throttle control cable, the accelerator rod, and the tachometer cable.

3. Connect the choke control cable, the governor control rod, the

heater hose, and the radiator hose. Install the coil and connect the temperature sending unit wire.

On a truck with conventional brakes, connect the vacuum assist brake line.

4. Install the cooling system by-pass lines, and the distributor cap and spark plug wire assembly. Connect the coil high tension lead and the radiator upper hose. Fill and bleed the cooling system. Operate the engine at fast idle and check for coolant leaks. Install the air cleaner.

### VALVE PUSH ROD COVER

#### REMOVAL

Remove the intake manifold and related parts. Scribe a line on the distributor housing and block to mark the position of the distributor in the block and scribe a line on the housing to mark the position of the rotor. Remove the distributor. Remove the valve push rod cover retaining screws, then remove the cover and gasket.

#### INSTALLATION

1. Coat one side of the valve push rod cover gasket with oil resistant sealer, and lay the cemented side of the gasket in place on the block. Position the cover, making sure that the gasket seats evenly all around the block. Install the retaining screws and tighten them as shown in Fig. 18.

2. Install the distributor, using the scribed lines as guides to properly position the rotor and housing.

If the crankshaft was rotated, turn the engine until the No. 1 piston is on T.D.C., then position the distributor in the block with the rotor at the No.

Labels in diagram: REAR THERMOSTAT COVER, LOW TEMPERATURE THERMOSTAT, INTAKE MANIFOLD, AIR VENT VALVE, COOLANT OUTLET ELBOW, HIGH TEMPERATURE THERMOSTAT.

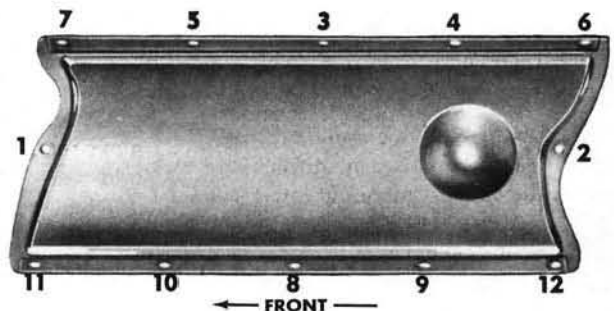
**100% SATISFACTION GUARANTEED**

**BUY IT NOW!**

**Click Here To Order**

1712-A

PayPal, American Express, Discover, MasterCard, VISA



BOLTS NUMBERED 1 AND 2 TORQUE TO 10 FT. LBS.

BOLTS NUMBERED 3 THROUGH 12 TORQUE TO 5 FT. LBS.

178

FIG. 18—Valve Push Rod Cover Bolt Tightening Procedure

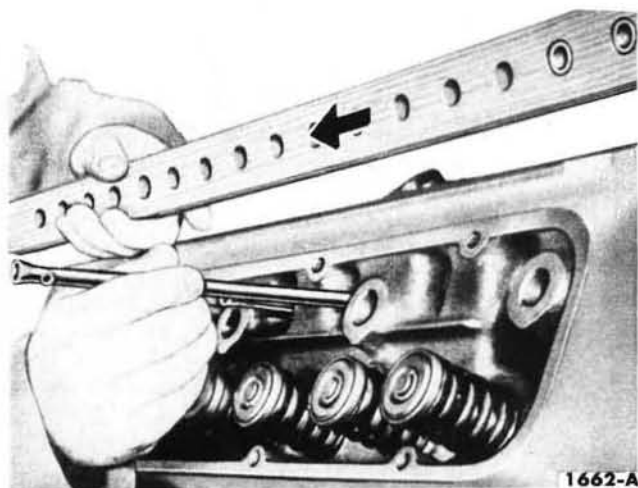


FIG. 19—Valve Push Rod Removal

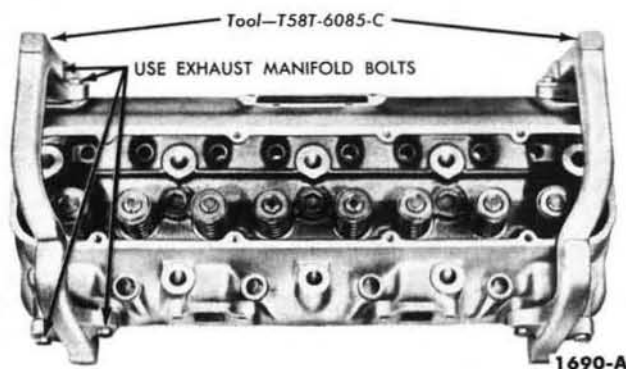


FIG. 21—Cylinder Head Holding Fixtures

1 firing position and the breaker points open. Install the hold down clamp.

3. Install the intake manifold and related parts.

#### EXHAUST MANIFOLDS

The procedures apply to either a right or left installation.

#### REMOVAL

1. Remove the exhaust manifold upper retaining bolts and tab washers.

2. Disconnect the muffler inlet pipe from the exhaust manifold. Remove the exhaust manifold lower retaining bolts and tab washers and remove the exhaust manifold and gasket.

over the muffler inlet pipe studs.

2. Position the exhaust manifold and gasket on the cylinder head and install the retaining bolts and tab washers. Tighten the retaining bolts to 23-28 foot-pounds torque, working from the center to the ends. Lock each bolt by bending a tab of the washer over a flat on the bolt. Connect the muffler inlet pipe and tighten the nuts to 23-28 foot-pounds torque.

#### CYLINDER HEAD REMOVAL

1. Drain the cooling system. Remove the air cleaner, the intake manifold assembly, and the valve rocker arm covers. Disconnect the muffler inlet pipes at the exhaust manifolds.

2. Release the spring tension on the valve rocker arms by loosening the adjusting screws. Remove the valve rocker arm shaft assembly retaining bolts, then remove the assembly from the oil baffle plate.

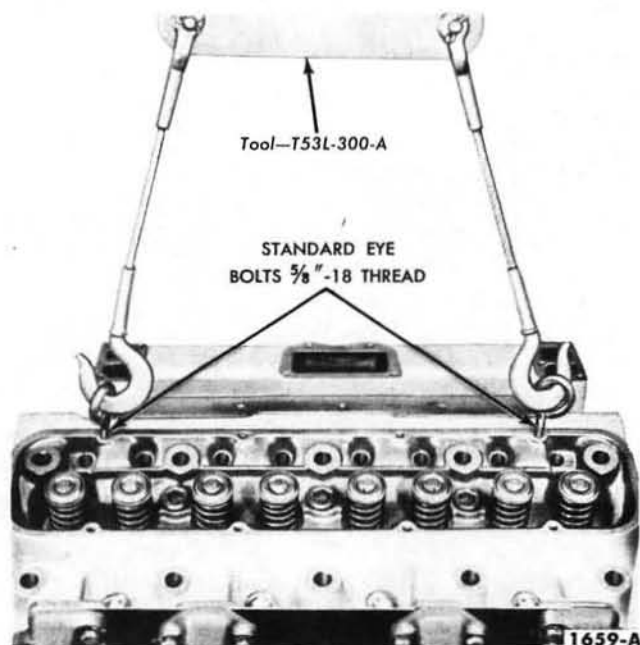


FIG. 20—Cylinder Head Removal or Installation

Because five cylinder head bolts also serve as pedestals for the valve rocker arm shaft assembly, each time the valve rocker arm shaft assembly is removed, the cylinder head gasket must be replaced. Remove the valve push rods in sequence (Fig. 19).

3. Install standard eye bolts with  $\frac{5}{8}$ -18 threads in the cylinder head and attach the engine lifting sling (Fig. 20). Remove the remaining cylinder head bolts. Raise the cylinder head and carefully remove it from the engine.

4. Place the cylinder head on a work bench and remove the exhaust manifold and heat deflector, then install the holding fixtures (Fig. 21).

#### VALVE ROCKER ARM SHAFT DISASSEMBLY

1. Remove the cotter pins from each end of the valve rocker arm shaft, then slide the rocker arms, springs, and the supports off the shaft. Be sure to identify all parts.

2. If it is necessary to remove the plugs from each end of the shaft, drill or pierce one plug, then insert a steel rod through the plug and knock out the plug on the opposite end. Working from the open end, knock out the remaining plug.

100% SATISFACTORY GUARANTEED

**BUY IT NOW!**

Click Here To Order

1. exha grap

PayPal

MasterCard

DISCOVER

VISA



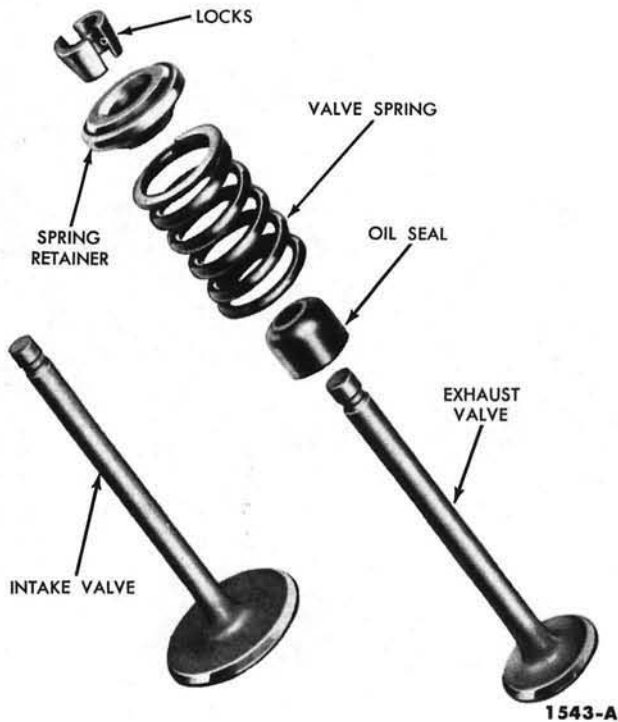


FIG. 24—Valve Assembly

0.030-inch thick spacer(s) between the cylinder head spring pad and the valve spring to bring the assembled height to the recommended dimension of  $1\frac{3}{64}$ — $1\frac{45}{64}$  inches. **Do not install spacers unless necessary. Use of spacers in excess of recommendations will result in overstressing the valve springs which will lead to excessive load loss and spring breakage.** Install the spark plugs.

### CYLINDER HEAD INSTALLATION

1. Clean the old gasket from the cylinder head and block gasket surfaces. Remove the cylinder head holding fixtures and install the gaskets and the exhaust manifolds and the spark plugs. Install standard eye bolts with  $\frac{5}{8}$ -18 threads in the cylinder head and attach the engine lifting sling.

use sealer on the cyl-

**100% SATISFACTION GUARANTEED**  
**BUY IT NOW!**  
 Click Here To Order

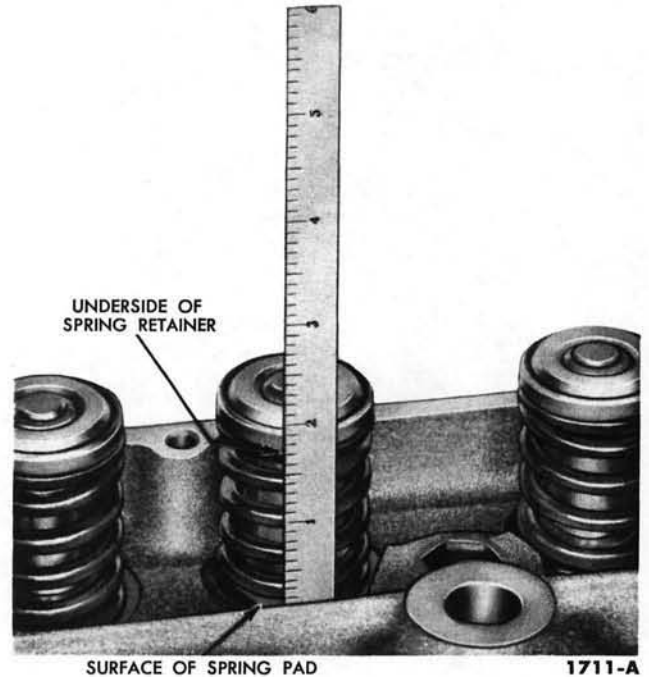


FIG. 25—Valve Spring Assembled Height

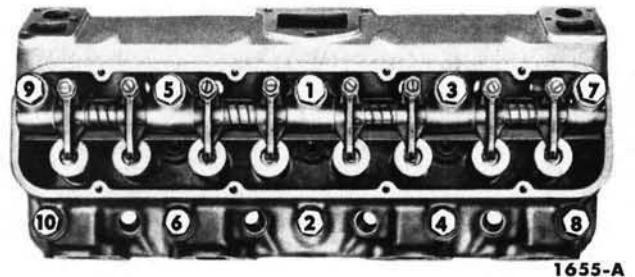


FIG. 26—Cylinder Head Bolt Tightening Sequence

Remove the lifting sling and eye bolts. Install the push rods in their proper sequence making sure the lower ends are positioned in the tappet socket.

4. Position the oil baffle plate and the valve rocker arm shaft assembly on the cylinder head. Install, but do not tighten, the remaining five cylinder head bolts.

5. The cylinder head bolt tightening procedure is performed in three progressive steps. Tighten the bolts to 110-120 foot-pounds torque in the proper sequence (Fig. 26), then tighten them to 120-130 foot-pounds torque in the same sequence. Finally, tighten the bolts to 130-150 foot-pounds torque in the same sequence. **After the cylinder head bolts have tightened to specifications, the should not be disturbed. Per-**

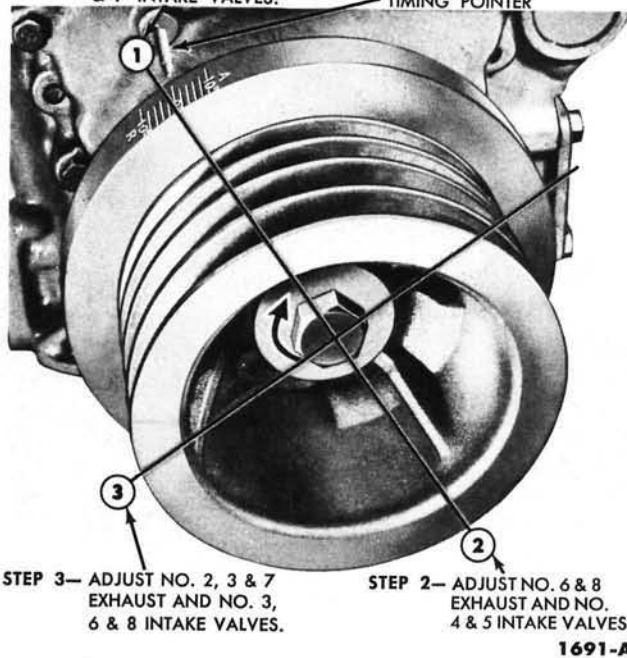
form a preliminary valve lash adjustment.

6. Install the intake manifold and related parts. Connect the muffler inlet pipes to the exhaust manifolds.

7. Fill and bleed the cooling system. Operate the engine until the engine temperatures have stabilized, then check the valve lash with the engine idling and adjust it if necessary. Check all hose connections and gaskets for leaks.

8. Coat one side of the valve rocker arm cover gaskets with oil resistant sealer, and lay the cemented side of the gaskets in place in the covers. Install the covers, making sure that the gaskets seat evenly all around the head. Install the retaining screws and tighten them to 4-5 foot-pounds torque. Install the air cleaner.

STEP 1— SET NO. 1 PISTON ON T.D.C., AT END OF COMPRESSION STROKE— ADJUST NO. 1, 4 & 5 EXHAUST AND NO. 1, 2 & 7 INTAKE VALVES.



STEP 3— ADJUST NO. 2, 3 & 7 EXHAUST AND NO. 3, 6 & 8 INTAKE VALVES.

STEP 2— ADJUST NO. 6 & 8 EXHAUST AND NO. 4 & 5 INTAKE VALVES.

1691-A

FIG. 27—Preliminary Valve Lash Adjustment

### VALVE LASH ADJUSTMENT

It is very important that the valve lash be held as close as possible to the correct specifications. If the lash is set too close, the valves will open too early and close too late resulting in rough engine idle. Burning and warping of the valves will occur also, because the valves cannot make firm contact with the seats long enough to cool properly. If the lash is excessive, it will cause the valves to open too late and close too early causing valve bounce. In addition, damage to the camshaft lobe is likely because the tappet foot will not follow the pattern of the camshaft lobe causing a shock contact between these two parts.

If the valve rocker arm shaft assembly has been removed and installed, it will be necessary to make a preliminary (cold) valve lash adjustment before starting the engine. If the adjustment is made for an engine

tune-up, follow the final adjustment procedure.

The cylinders are numbered from front to rear—right bank, 1-2-3-4; left bank, 5-6-7-8. The valves are arranged from front to rear on both banks, E-I-E-I-E-I-E.

#### PRELIMINARY ADJUSTMENT

The cold valve lash setting for the intake valves is 0.020 inch and 0.022 inch for the exhaust valves. Use a step-type feeler gauge ("go" and "no go") to adjust the valves.

1. Make three chalk marks on the crankshaft damper (Fig. 27). Space the marks approximately 90° apart so that with the timing mark, the damper is divided into four equal parts (90° represents ¼ of the distance around the damper circumference).

2. Rotate the crankshaft until No. 1 piston is near T.D.C. at the end of

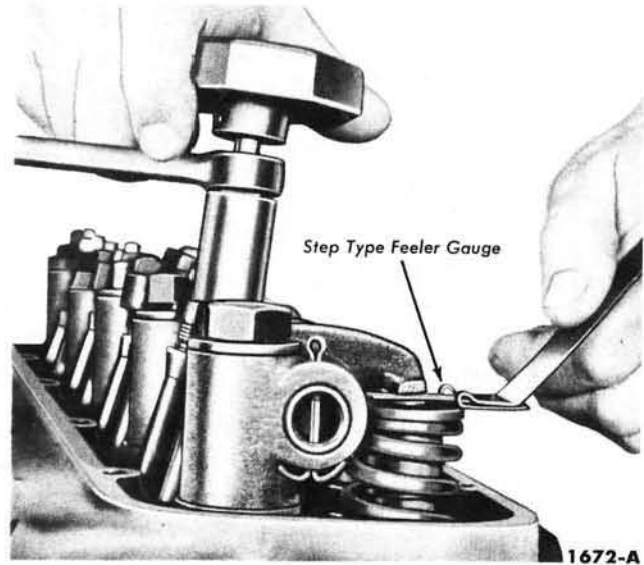


FIG. 28—Valve Lash Adjustment

the compression stroke, then adjust the following valves:

No. 1—Exhaust	No. 1—Intake
No. 4—Exhaust	No. 2—Intake
No. 5—Exhaust	No. 7—Intake

3. Rotate the crankshaft 180°, or ½ turn (this puts No. 4 piston on T.D.C.), then adjust the following valves:

No. 6—Exhaust	No. 4—Intake
No. 8—Exhaust	No. 5—Intake

4. Rotate the crankshaft 270°, or ¾ turn from 180° (this puts No. 3 piston on T.D.C.), then adjust the following valves:

No. 2—Exhaust	No. 3—Intake
No. 3—Exhaust	No. 6—Intake
No. 7—Exhaust	No. 8—Intake

#### FINAL ADJUSTMENT

Before a final valve lash adjustment is made, operate the engine for a minimum of 30 minutes at approximately 1200 rpm to stabilize engine temperatures. With the engine idling, check the valve lash using a step-type feeler gauge only ("go" and "no go"). Adjust the intake and exhaust valve lash (Fig. 28), to 0.020 inch.

## CRANKSHAFT DAMPER, CYLINDER FRONT COVER, AND TIMING GEARS

Remove the alternator, air compressor, and power steering belts.

On a F- or T-series truck, lift the front of the engine approximately

one inch with a floor jack to all removal of the damper.

2. Remove the damper cap screw and washer. Install the removal tool and remove the damper (Fig. 29).



**BUY IT NOW!**

**Click Here To Order**



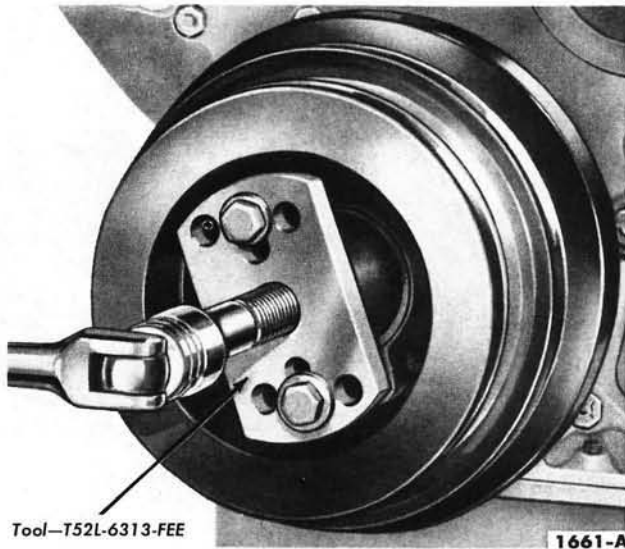


FIG. 29—Damper Removal

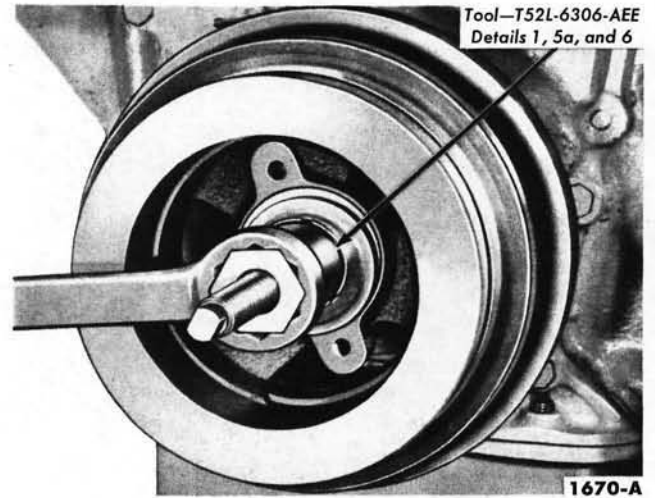


FIG. 30—Damper Installation

adjust the tension of the belts. Install the fan, shroud, and radiator. Fill and bleed the cooling system.

### CYLINDER FRONT COVER AND TIMING GEARS

#### REMOVAL

1. Drain the cooling system and the crankcase. Remove the fan, shroud, and radiator. Remove the alternator, power steering pump, and air compressor drive belts. Remove the air compressor idler pulley and disconnect the alternator adjusting arm at the cylinder front cover. Remove the water pump assembly, the crankshaft damper, the engine front support bracket, and the oil level dipstick.

2. Remove the screws fastening the cylinder front cover to the block and oil pan, then remove the cylinder front cover. Discard the cylinder front cover gasket. Remove the oil pan and discard the gasket.

3. Remove the crankshaft front oil slinger. Align the timing marks on the timing gears (Fig. 31) and remove the camshaft gear retaining bolts, then remove the camshaft gear.

4. To remove the crankshaft gear, install the tool shown in Fig. 32 and pull the gear off the shaft.

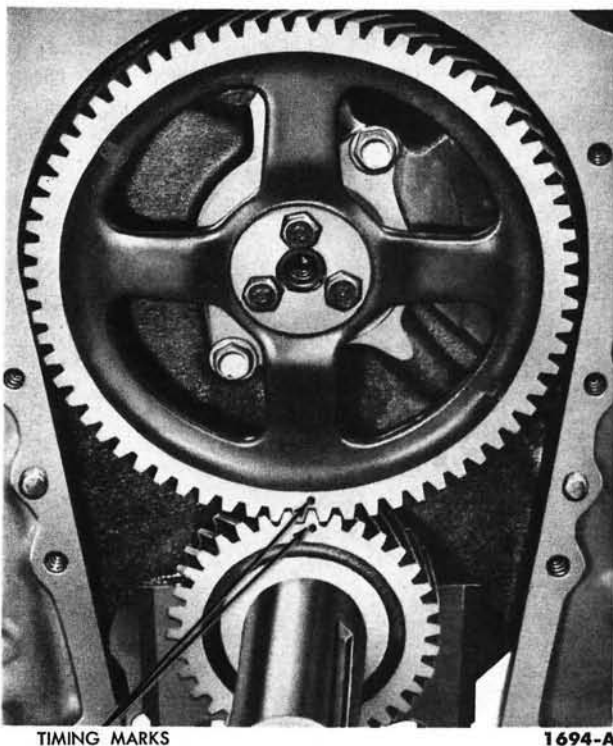


FIG. 31—Timing Gear Alignment

On a F- or T-series truck, lower engine and remove the floor jack.

Install the damper washer and screw, then tighten the screw to -145 foot-pounds torque.

Install the power steering, air compressor, and alternator belts and

#### OIL SEAL REPLACEMENT

It is good practice to replace the oil seal each time the cylinder front cover is removed.

1. Drive out the old seal with a pin punch, then clean out the recess in the cover.

IF **100% SATISFACTION GUARANTEED**

**BUY IT NOW!**

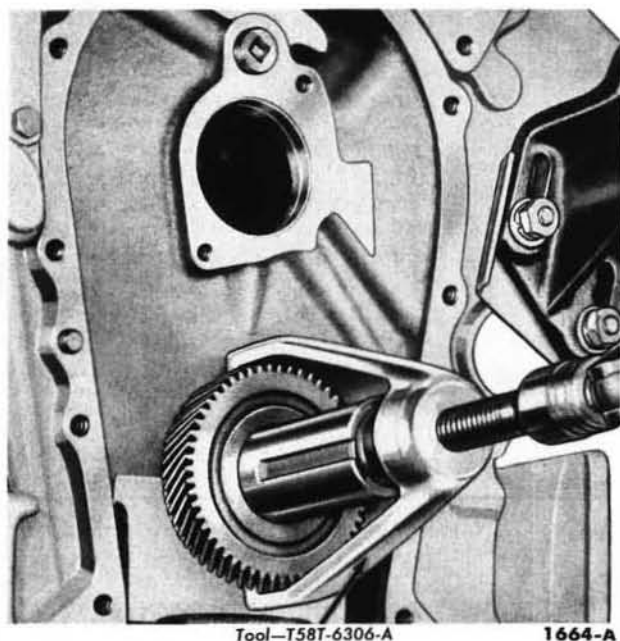
**Click Here To Order**

gre with ins

PayPal

MasterCard

VISA



Tool—T58T-6306-A

1664-A

FIG. 32—Crankshaft Gear Removal

2. Coat a new seal with grease, then install the seal (Fig. 33). Drive the seal in until it is fully seated in the recess. Check the seal after installation to be sure the spring is properly positioned in the seal.

#### INSTALLATION

1. Install the crankshaft gear (Fig. 34) and the camshaft gear with the timing marks aligned (Fig. 31), then install the camshaft gear retaining bolts. **The bolts are unequally spaced.** Tighten the bolts to 12-15 foot-pounds torque. Install the crankshaft front oil slinger.

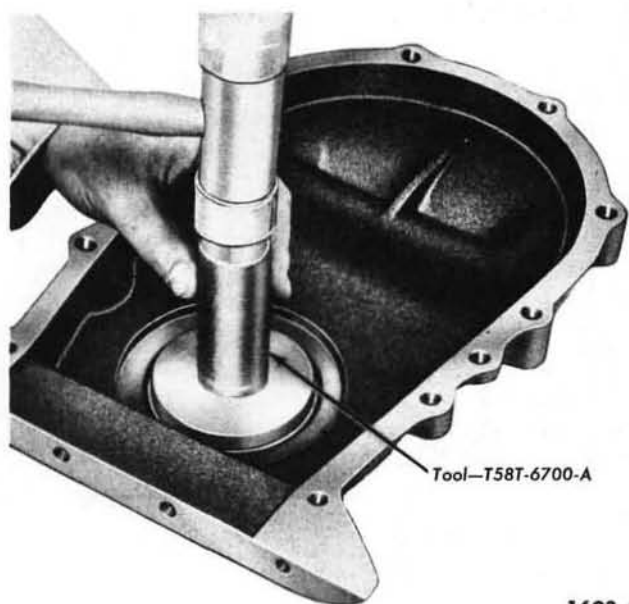
2. Clean the cylinder front cover, water pump, oil pan, and the cylinder block gasket surfaces. Coat the gasket surface of the cylinder front cover and block and the cover bolt threads with sealer. Position a new cylinder front cover gasket on the block. Install the cylinder front cover.

3. Install the cylinder front cover retaining bolts and tighten them to 23-28 foot-pounds torque.

4. Apply sealer to the oil pan gasket surface and position a new gasket on the oil pan, then install the oil pan.

5. Install the engine front support bracket, and the crankshaft damper. Apply sealer to the water pump gasket and position it on the block, then install the water pump assembly. Install the air compressor idler pulley and the alternator adjusting arm on the cylinder front cover. Install and adjust the drive belts. Install the oil level dipstick. Install the fan, shroud, and radiator.

6. Fill and bleed the cooling system. Fill the crankcase with the proper grade and quantity of engine oil.



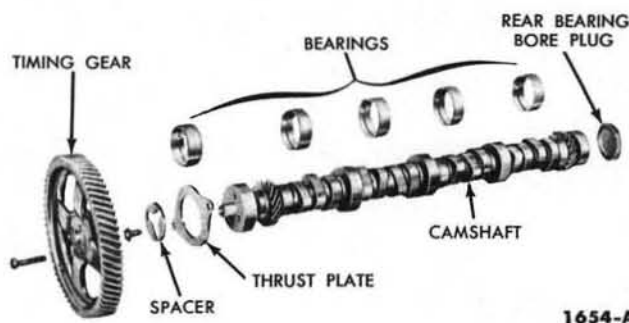
Tool—T58T-6700-A

1693-A

FIG. 33—Oil Seal Installation



1565-A



1654-A

FIG. 35—Camshaft and Related Parts

**100% SATISFACTION GUARANTEED**

**BUY IT NOW!**

**Click Here To Order**

PayPal | American Express | Discover | MasterCard | VISA

## CAMSHAFT, BEARINGS, AND TAPPETS

### CAMSHAFT

The camshaft and related parts are shown in Fig. 35.

#### REMOVAL

1. Drain the cooling system and the crankcase. Remove the air cleaner. Remove the fan, shroud, and radiator. Remove the water pump, intake manifold assembly, valve rocker arm covers, valve rocker arm shaft assemblies, the valve push rods in sequence, and the cylinder heads. Remove the cylinder front cover, oil level dipstick, and the oil pan. Remove the distributor, governor, and the valve push rod cover.

2. Remove the valve tappets keeping them in order so that they can be replaced in their original position (Fig. 36).

3. Remove the crankshaft front oil slinger. Align the timing marks on the camshaft and crankshaft timing gears (Fig. 31).

4. Remove the camshaft thrust plate retaining bolts, then remove the camshaft gear, spacer, thrust plate, and camshaft as an assembly (Fig. 37).

#### INSTALLATION

1. Oil the camshaft and carefully slide it through the bearings with the gear, spacer and thrust plate attached (Fig. 37). Be sure the camshaft is installed so that the timing mark on the camshaft gear is aligned with the timing mark on the crankshaft gear (Fig. 31). Install the thrust plate retaining bolts and tighten them to 12-15 foot-pounds torque.

If a new camshaft is to be installed, remove the gear, spacer, and thrust plate from the old camshaft and install them on the new camshaft, then install the camshaft.

2. Install the crankshaft front oil slinger, the cylinder front cover, crankshaft damper, the water pump, the oil pan, and the oil level dipstick.

3. Install the valve tappets in sequence. Install the valve tappet chamber gasket and cover and the governor. Rotate the engine until No. 1 piston is on T.D.C. Position the distributor in the block with the rotor at the No. 1 firing position and the breaker points open, and install the hold down clamp.

4. Install the cylinder heads, the

push rods in sequence, and the valve rocker arm shaft assemblies. Perform a preliminary valve lash adjustment. Install the intake manifold assembly and related parts. Install the distributor cap and connect the spark plug wires and the coil high tension lead.

5. Install the fan, shroud, and radiator. Fill and bleed the cooling system. Fill the crankcase with the proper grade and quantity of engine oil. Start the engine. Adjust the ignition timing. Check all hose connections and gaskets for leaks. Operate the engine until the engine temperatures have stabilized, then check and adjust the valve lash. Install the valve rocker arm covers and the air cleaner.

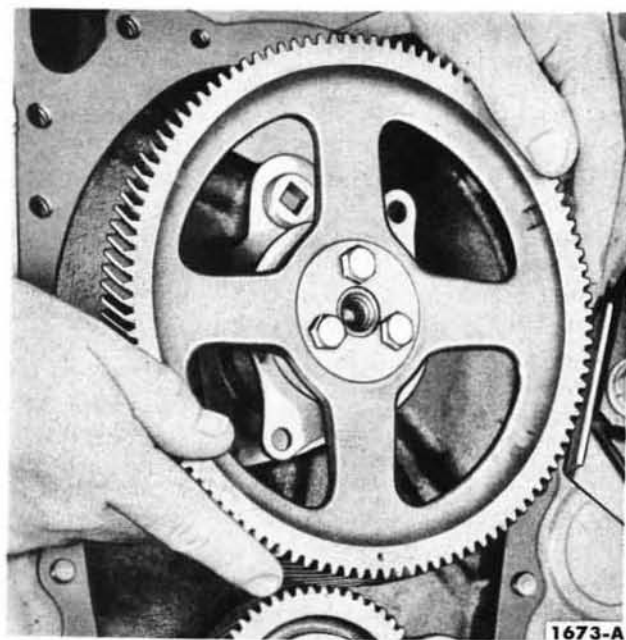
### BEARING REPLACEMENT

It will be necessary to remove the engine from the chassis to replace camshaft bearings. Camshaft bearings are available pre-finished to size for standard and 0.015 inch undersize journal diameters. The No. 1 camshaft bearing is not interchangeable with the other bearings.

1. Remove the engine, then remove the camshaft, the flywheel, and the crankshaft. Push the pistons to the top of the cylinders to move the connecting rods out of the way.



1660-A



1673-A

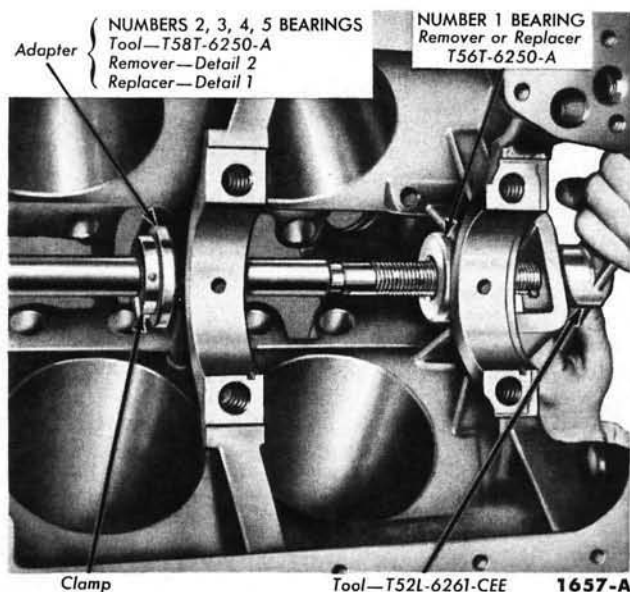
**BUY IT NOW!**

Click Here To Order

FIG.

FIG. 37—Camshaft Removal or Installation





**FIG. 38—Camshaft Bearing Replacement**

2. Drill a 1/2-inch hole in the camshaft rear bearing bore plug and use tool T-7600-E to remove the plug. Remove the camshaft bearings (Fig. 38).

3. Position the new bearing at the bearing bore, and press it in place with the tool shown in Fig. 38. Align the oil holes in the bearings with the oil holes in the cylinder block when the bearings are installed. **Be sure the camshaft front bearing is installed 0.037-0.043 inch below the front face of the cylinder block.**

4. Clean out the camshaft rear bearing bore plug recess thoroughly. Coat the flange of a new plug with water resistant sealer and install it with the flange facing in (Fig. 39).

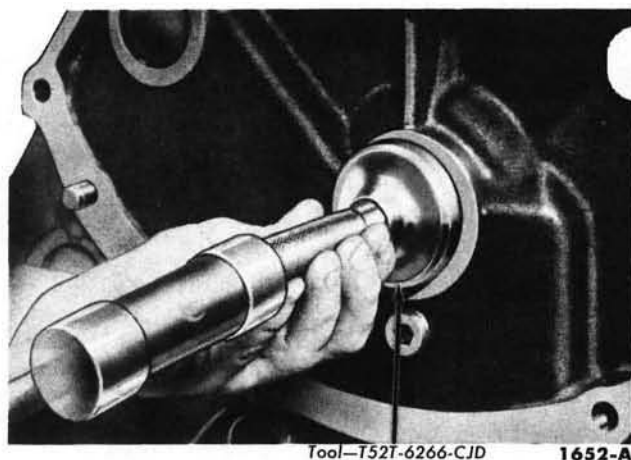
Drive the plug in until it is flush or slightly below the casting surface.

5. Install the camshaft, crankshaft, flywheel, and related parts. Install the engine in the chassis.

#### TAPPET REPLACEMENT

1. Drain the cooling system. Remove the intake manifold assembly, the valve rocker arm covers, the rocker arm shaft assemblies, and the cylinder heads. Scribe a line on the distributor housing and block to mark the position of the distributor in the block and scribe a line on the housing to mark the position of the rotor. Remove the distributor, then remove the valve push rod cover.

2. Oil the new tappets before in-



**FIG. 39—Camshaft Rear Bearing Bore Plug Installation**

stallation. Remove and replace one tappet at a time. If the tappets are difficult to remove, use the tool shown in Fig. 36.

3. Install the valve push rod cover. Install the distributor using the scribed lines as guides. Install the cylinder heads, valve push rods in sequence, the valve rocker arm shaft assemblies, and the intake manifold assembly. Perform a preliminary valve lash adjustment. Install the distributor cap and connect the spark plug wires and the coil high tension lead.

4. Fill and bleed the cooling system. Start the engine. Adjust the ignition timing. Check all hose connections and gaskets for leaks. Operate the engine until the engine temperatures have stabilized, then check and adjust the valve lash. Install the valve rocker arm covers and the air cleaner.

## 7 FLYWHEEL, CRANKSHAFT, CONNECTING RODS, AND PISTONS

### FLYWHEEL

The procedure for replacing the clutch pilot bushing is covered in Part 3-1.

### REMOVAL

Remove the transmission from the flywheel housing (Group 3), then remove the clutch from the flywheel (Group 3). After these components are removed, remove the flywheel bolts and remove the flywheel

Install the clutch and the transmission (Group 3). Install the flywheel housing dust cover.

### CRANKSHAFT

The crankshaft and related parts are shown in Fig. 40.

### REMOVAL

1. Drain the cooling system and the crankcase. Remove the fan, shroud, and radiator. Remove the engine from the chassis and install it on a work stand.

2. Loosen the alternator adjusting arm at the alternator and remove the arm from the cylinder front cover,

then remove the fan belt(s). Remove the water pump and pulley as an assembly. Loosen the power steering pump and remove the drive belt. Remove the air compressor idler pulley, spacer, and drive belt. Remove the crankshaft damper, engine front support, and damper key.

3. Invert the engine and remove the oil pan, oil pump, screen, and intermediate drive shaft. Remove the cylinder front cover and crankshaft front oil slinger. Mark the plate cover and remove the clutch cover and remove the flywheel.

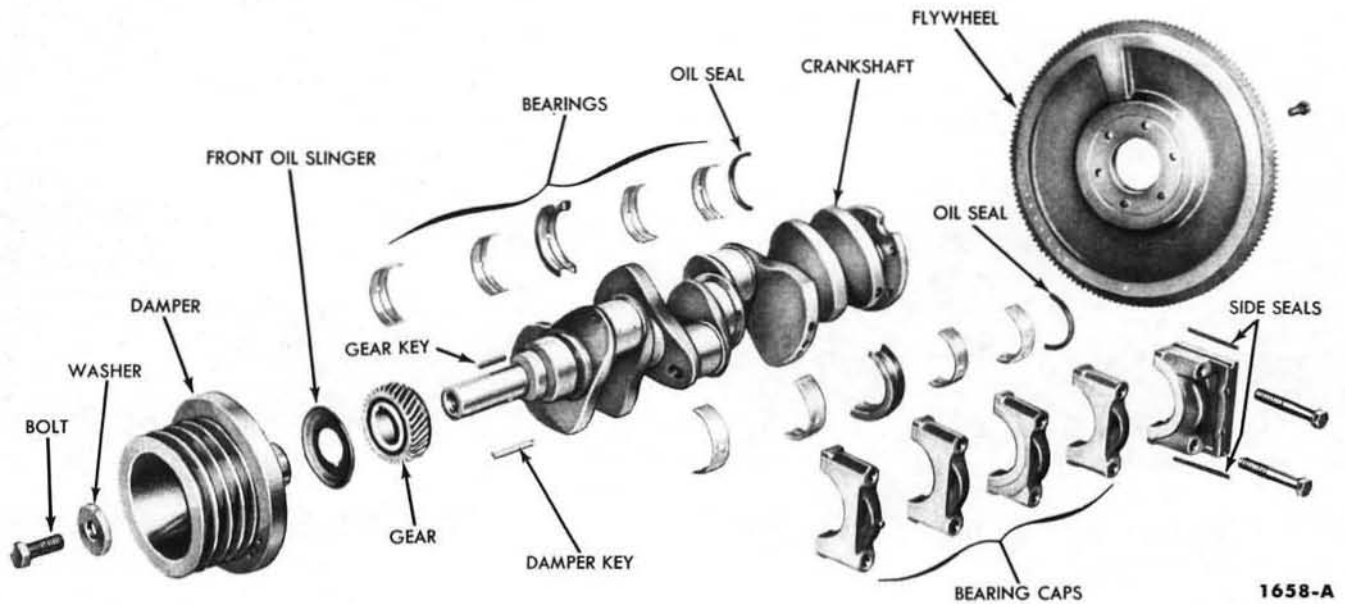
4. Make sure all bearing caps (main and connecting rod) are



**BUY IT NOW!**

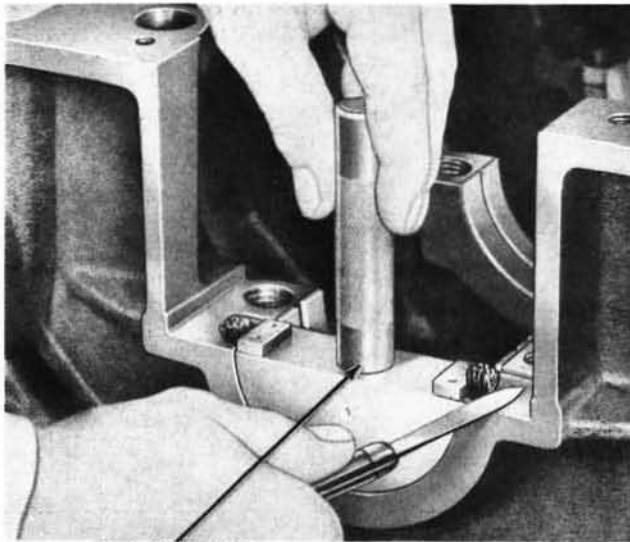
**Click Here To Order**





1658-A

FIG. 40—Crankshaft and Related Parts



Tool—T58T-6701-B

1569-A

FIG. 41—Seal to Block Installation

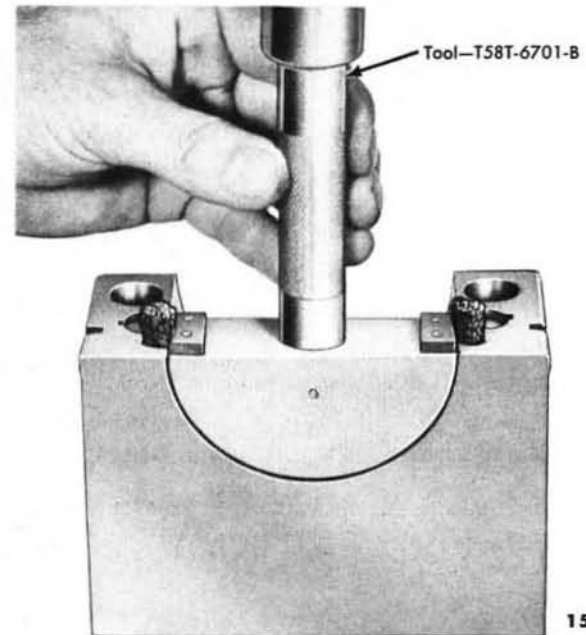
marked so they can be installed in their original locations. Remove the connecting rod bearing caps, then carefully push the piston and rod assemblies against the heads. Remove the main bearing caps.

5. Carefully lift the crankshaft and pull it out of the cylinder.

an  
b  
an  
ole  
surf  
seal

bearing cap, and remove the cap to block side seals.

6. If new main and/or connecting rod bearings are to be installed, remove the main bearing inserts from the block and bearing caps, and/or connecting rod bearing inserts from the connecting rods and caps. Install all new bearings following the procedures in Section 8 "Main and Connecting Rod Bearing Replace-



1576-A

FIG. 42—Seal to Bearing Cap Installation

#### INSTALLATION

If a new crankshaft is to be installed, remove the timing gear and key from the old shaft and install them on the new shaft.

1. Be sure that all bearings, crankshaft journals, and the rear journal oil seal grooves are clean. Install a new rear journal oil seal in the block (Fig. 41) and rear main bearing cap (Fig. 42). After installation, cut the



**BUY IT NOW!**

**Click Here To Order**



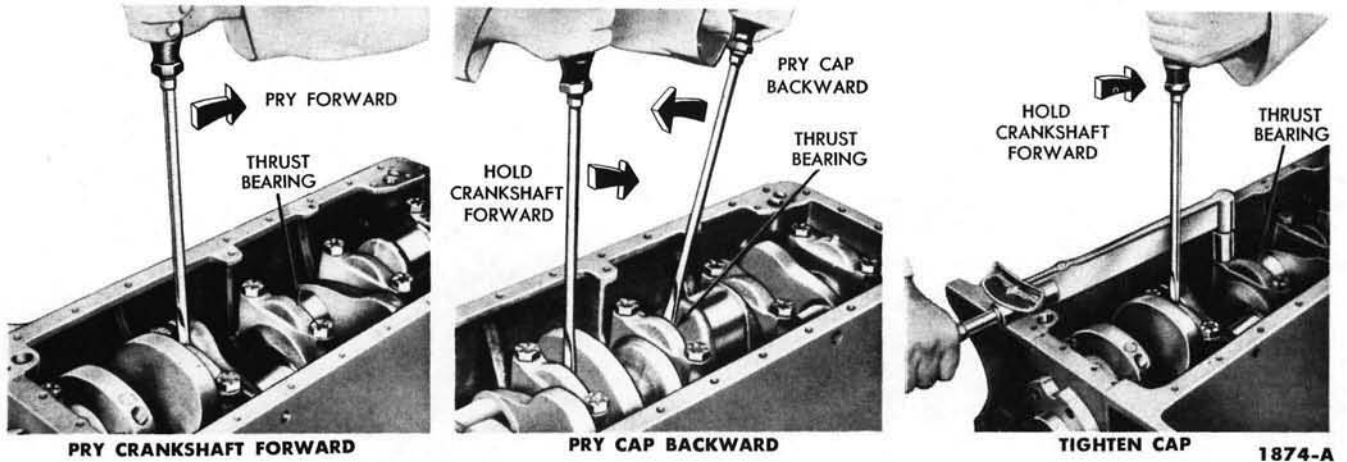


FIG. 43—Thrust Bearing Alignment

ends of the seals leaving approximately 0.010 inch of the seal protruding from the block and bearing cap.

2. Carefully lower the crankshaft and timing gear into place. **Be careful not to damage the bearing surfaces.**

3. Check the clearance of each main bearing following the procedure under "Main Bearing Replacement" in Section 8. If the bearing clearances are satisfactory, apply a light coat of engine oil to the journals and bearings, then install all the bearing caps, except the thrust bearing cap (No. 3 bearing). Tighten the bearing cap bolts to 150-164 foot-pounds torque. Dip the rear bearing cap side seals in light engine oil, then immediately install them in the grooves. **Do not use sealer on the side seals, the seals are designed to expand when dipped in oil. Using sealer may retard this expansion.** It may be necessary to tap the seals into place for the last 1/2 inch of travel. Do not cut the seal projecting ends. Check the rear main bearing cap side seals for leaks by squirting a few drops of oil into the parting lines between the bearing cap and the cylinder block from the outside. Blow compressed air against the seals from the inside of the block. If leaks appear in the oil, it indi-

4. Install the thrust bearing cap with the bolts finger tight, then pry the crankshaft forward against the thrust surface of the upper half of the bearing (Fig. 43). Hold the crankshaft forward and pry the thrust bearing cap to the rear (Fig. 43). This will align the thrust surfaces of both halves of the bearing. Retain the forward pressure on the crankshaft, and tighten the cap bolts to 150-164 foot-

pounds torque (Fig. 43).

5. Force the crankshaft toward the rear of the engine. Install a dial indicator so the contact point rests against the crankshaft flange and the indicator axis is parallel to the crankshaft axis (Fig. 44). Set the dial on zero, then push the crankshaft forward and note the reading on the dial.

If the end play exceeds the wear limit, replace the thrust bearing. If

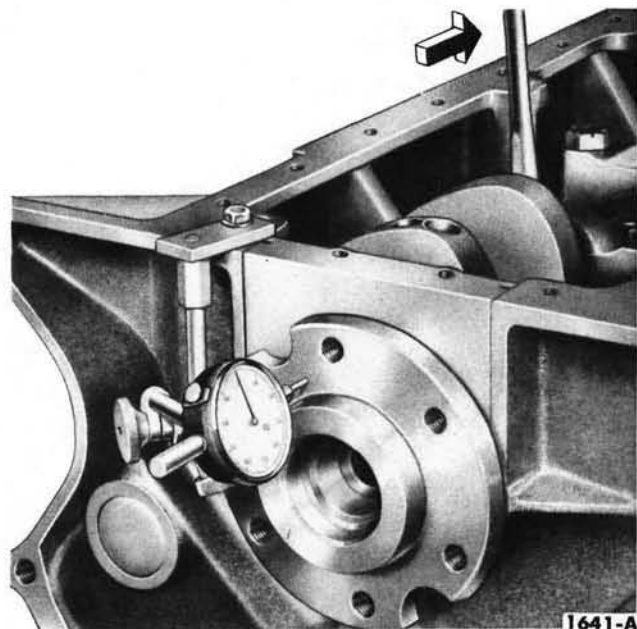


FIG. 44—Crankshaft End Play

**100% SATISFACTION GUARANTEED**

**BUY IT NOW!**

**Click Here To Order**

PayPal American Express Discover Novus MasterCard VISA

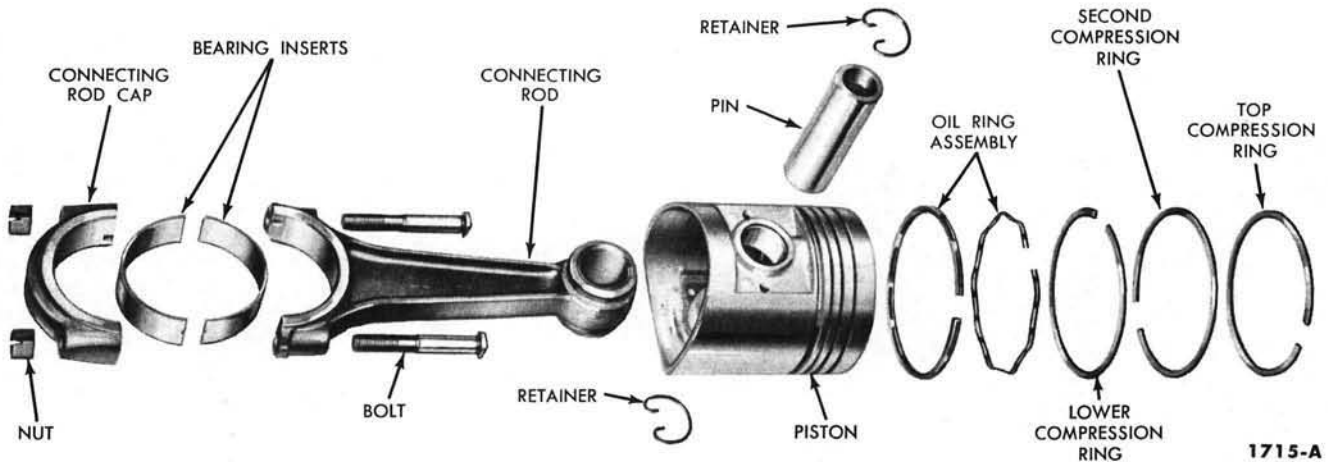


FIG. 45—Piston, Connecting Rod, and Related Parts

the end play is less than the minimum limit, inspect the thrust bearing faces for scratches, burrs, nicks, or dirt. If the thrust faces are not defective or dirty, they probably were not aligned properly. Install the thrust bearing and align the faces following the recommended procedure (step 4), then recheck the end play.

6. Check the clearances of each connecting rod bearing following the procedure under "Connecting Rod Bearing Replacement" in Section 8. If the bearing clearances are satisfactory, apply a light coat of engine oil to the journals and bearings, then install the connecting rod caps. Tighten all the nuts to 50-55 foot-pounds torque. Check the side clearance between the connecting rods on each crankshaft journal following the procedure under "Piston and Connecting Rod Installation."

7. Be sure the timing marks are aligned, then install the crankshaft front oil slinger, cylinder front cover, engine front support, and the crankshaft damper. Install the flywheel, clutch discs, and pressure plate. Install the intermediate drive shaft, oil pump, and screen assembly. Install the oil pan. Install the water pump and pulley. Install the air compressor idler pulley, spacer, and drive belt. Install and adjust the power steering pump drive belt. Connect the alternator adjusting arm to the cylinder front cover. Install and adjust the fan belt. Tighten all alternator

engine and adjust the ignition timing. Operate the engine at fast idle and check for oil pressure and check all hose connections and gaskets for leaks.

#### PISTON AND CONNECTING ROD REMOVAL

The piston and connecting rod assembly is shown in Fig. 45.

1. Drain the cooling system and the crankcase. Remove the air cleaner. Remove the valve rocker arm covers, the valve rocker arm shaft assemblies, and the valve push rods in sequence. Remove the intake manifold assembly and the cylinder heads. Remove the oil pan, oil pump and pick-up tube, and the intermediate drive shaft.

2. Before removing the piston assemblies, remove any ridge and/or deposits from the upper end of the cylinder bores with tool 3036 or its equivalent. Move the piston to the

bottom of its travel and place a cloth on the piston head to collect the cuttings. Remove the cylinder ridge following the instructions furnished by the tool manufacturer. **Never cut into the ring travel in excess of 1/32 inch when removing ridges.** After the ridge has been removed, remove the cutter from the cylinder bore, then turn the crankshaft until the piston is at the top of its stroke and carefully remove the cloth with the cuttings.

3. Turn the crankshaft until the connecting rod being removed is down. Remove the nuts from the connecting rod bolts, then pull the cap off the rod. Push the connecting rod and piston assembly out the top of the cylinder with the handle end of a hammer. **Avoid damage to the crankshaft journal or the cylinder wall when removing the piston and rod.**

4. If new piston rings are to be installed and the cylinder has not



FIG. 46—Connecting Rod and Piston Assembly



**BUY IT NOW!**

**Click Here To Order**

Ins  
Fill  
the  
and





FIG. 47—Checking Ring Side Clearance

been refinished, remove the glaze from the cylinder wall by passing a fine grit hone or glaze removal tool through the bore a few times. Do not hone more than enough to rough up the finish. Thoroughly clean the cylinder walls and block after the glaze is removed, then oil the walls.

5. Repeat this procedure on each assembly.

#### PISTON AND CONNECTING ROD DISASSEMBLY

Mark the pistons and pins to assure assembly with the same rod and installation in the same cylinder from which they were removed. Remove the piston rings. Remove the piston pin retainers, then drive the pin out of the piston and connecting rod. Discard the retainers.

#### PISTON AND CONNECTING ROD ASSEMBLY

1. Lubricate all parts with light engine oil. Position the connecting rod in the piston and push the pin into place. Assemble the piston and connecting rod as shown in Fig. 48.

2. Insert new piston pin retainers by spiraling them into the piston with screwdrivers. Do not use pliers. Follow instructions contained on the pin

should slide freely around the entire ring circumference without binding. Any wear that occurs will form a step at the inner portion of the lower land. **If the lower lands have high steps, the piston should be replaced.**

4. Be sure the bearings and journals are clean. If it is necessary to replace the connecting rod bearings, replace them at this time following the procedure under "Connecting Rod Bearing Replacement" in Section 8.

#### PISTON AND CONNECTING ROD INSTALLATION

Be sure to install the pistons in the same cylinders from which they were

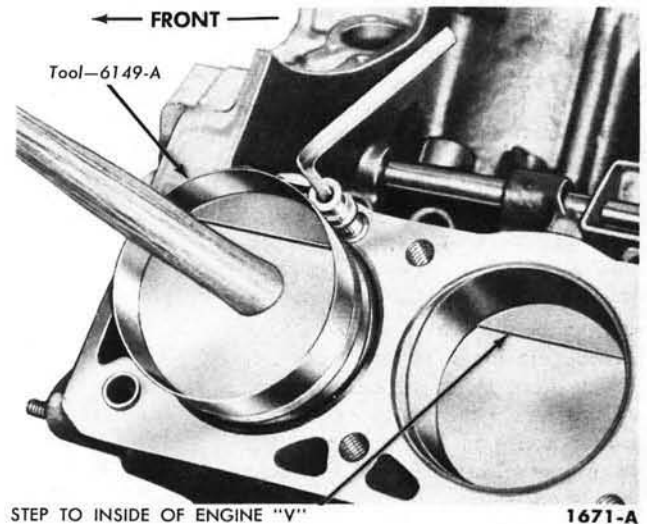
removed, or to which they were fitted. Each connecting rod and bearing cap is numbered from 1 to 4 in the right bank and from 5 to 8 in the left bank, beginning at the front of the engine. The numbers on the connecting rod and bearing cap must be on the same side when installed in the cylinder bore. If a connecting rod is ever transposed from one block or cylinder to another, new bearings should be fitted and the connecting rod should be numbered to correspond with the new cylinder number.

1. Oil the piston rings, pistons, and cylinder walls with light engine oil.

2. Make sure the ring gaps are properly spaced around the circumference of the piston. Install a piston ring compressor on the piston and push the piston in with a hammer handle until it is slightly below the top of the cylinder (Fig. 48). Be sure to guide the connecting rods to avoid damaging the crankshaft journals. **When installed, the bearing lock slots in the connecting rod should be toward the outside of the engine.**

3. Check the clearance of each bearing following the procedure under "Connecting Rod Bearing Replacement" in Section 8. If the bearing clearances are to specifications, apply a light coat of engine oil to the journals and bearings.

4. Turn the crankshaft throw to the bottom of its stroke, then push the piston all the way down until the connecting rod bearing seats on the crankshaft journal. Install the connecting rod cap, then tighten the nuts to 50-55 foot-pounds torque.



STEP TO INSIDE OF ENGINE "V"

FIG. 48—Piston Installation

**100% SATISFACTION GUARANTEED**

**BUY IT NOW!**

**Click Here To Order**

PayPal American Express Discover Novus MasterCard VISA

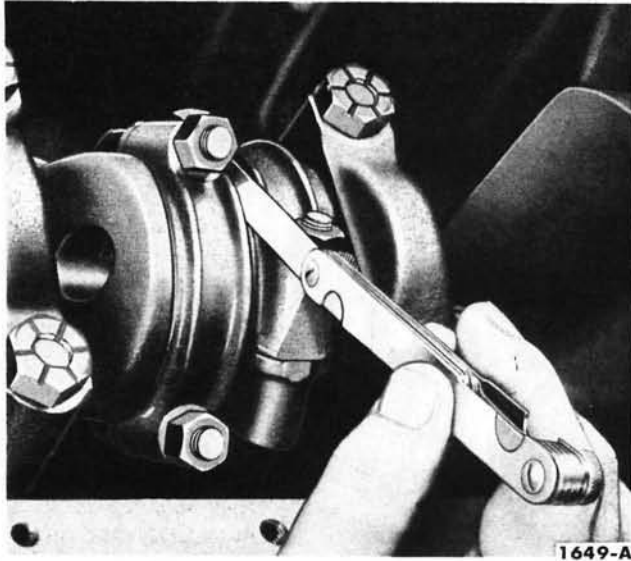


FIG. 49—Connecting Rod Side Clearance

5. After the piston and connecting rod assemblies have been installed, check the side clearance between the connecting rods on each crankshaft journal (Fig. 49).

6. Install the intermediate drive shaft, oil pump, and screen assembly. Install the oil pan. Install the cylinder heads, valve push rods in sequence, the valve rocker arm shaft assemblies, and the intake manifold assembly. Perform a preliminary valve lash adjustment. Install the distributor cap and connect the spark plugs and the coil high tension lead. Fill and bleed the cooling system. Fill the crankcase with the proper grade and quantity of engine oil.

7. Start the engine and operate it until the engine temperatures have stabilized, then check and adjust the valve lash. Check for oil and coolant leaks. Install the valve rocker arm covers and the air cleaner.

## 8 MAIN AND CONNECTING ROD BEARING REPLACEMENT

The main and connecting rod bearing inserts are selective fit and do not require reaming to size upon installation. **Do not file or lap bearing caps or use shims to obtain the proper bearing clearance.**

Selective fit bearings are available for service in standard sizes only. Standard bearings are divided into two sizes and are identified by a daub of red or blue paint. **Red marked bearings increase the clearance; blue marked bearings decrease the clearance.** Undersize bearings, which are not selective fit, are available for use on journals that have been refinished.

Normally, bearing journals wear evenly and are not out-of-round. However, if a bearing is being fitted to an out-of-round journal, be sure to fit the bearing to the maximum diameter of the journal. If the bearing is fitted to the minimum diameter with minimum clearance, interference may result, causing an early failure. It is not recommended that bearings be fitted to a journal which exceeds maximum out-of-round.

When replacing stand-

may distort the bearing and cause bearing failure.

### MAIN BEARING REPLACEMENT

The following procedure is for the engine installed in the chassis with the crankshaft not removed. If the engine is on a work stand, omit step 1 and follow steps 2-5. In step 4, if the engine is on a work stand, it is not necessary to support the crankshaft because the engine will be inverted. Also in step 4, place the Plastigage on the crankshaft journal (Fig. 50) instead of on the bearing surface if the engine is on a work stand.

1. Drain the crankcase. Remove the oil level dipstick, the oil pan, the oil pump and pick-up tube assembly, and the intermediate drive shaft.

2. Replace one bearing at a time,

leaving the other bearings securely fastened. Remove the main bearing cap to which new bearings are to be installed. Insert the upper bearing removal tool (tool 6331) in the oil hole in the crankshaft. Rotate the crankshaft in the direction of engine rotation to force the bearing out of the block.

3. To install the upper main bearing, place the plain end of the bearing over the shaft on the locking tang side of the block. Using tool 6331, rotate the crankshaft in the opposite direction of engine rotation until the bearing seats itself. Remove the tool. Replace the cap bearing. Clean the crankshaft journal and bearings.

4. Support the crankshaft so its weight will not compress the Plastigage and provide an erroneous read-

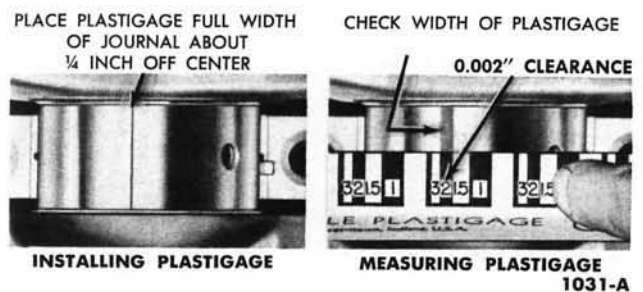


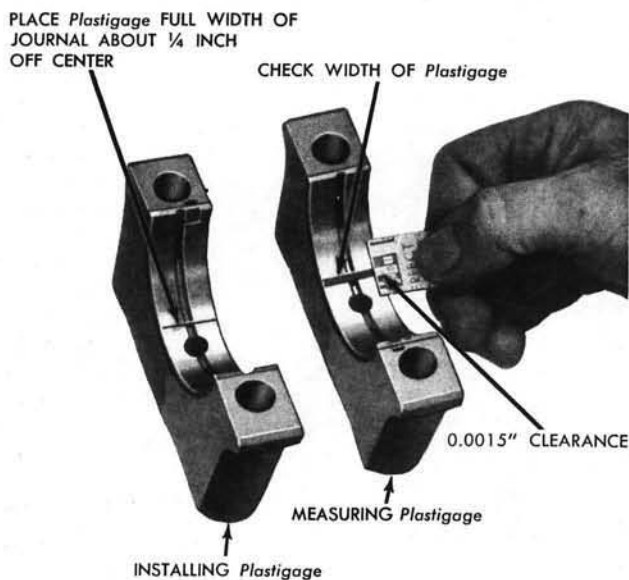
FIG. 50—Installing and Measuring Plastigage—Engine on Work Stand



**BUY IT NOW!**

**Click Here To Order**





1558-B

**FIG. 51—Installing and Measuring Plastigage—  
Engine in Chassis**

ing. Position a small jack so it will bear against the counterweight adjoining the bearing which is being checked. Place a piece of Plastigage on the bearing surface the full width of the bearing cap and about  $\frac{1}{4}$  inch off center (Fig. 51). Install the cap and tighten the bolts to 150-164 foot-pounds torque. **Do not turn the crankshaft while the Plastigage is in place.** Remove the cap, then using the Plastigage scale, check the width of the Plastigage at the widest point in order to get the minimum clearance. Check the Plastigage at the narrowest point in order to get the maximum clearance. The difference between the two readings is the taper.

If the clearance is less than the specified limits, try two red bearing halves or a combination of red and blue depending upon the condition. If the standard bearings do not bring the clearance within the desired limits, refinish the crankshaft journal, then install undersize bearings.

5. After the bearing has been checked and found to be satisfactory, apply a light coat of engine oil to the journal and bearings, then install the bearing cap. Tighten the cap bolts to 150-164 foot-pounds torque.

6. If the rear main bearing is replaced, replace the lower oil seal (in the cap) and the side seals. The upper oil seal (in the block) can not be replaced with the crankshaft installed.

7. Install the intermediate drive shaft, oil pump, and inlet tube and screen assembly. Install the oil pan. Fill the crankcase.

8. Operate the engine at fast idle and check for oil pressure and oil leaks.

### CONNECTING ROD BEARING REPLACEMENT

1. Drain the crankcase. Remove the oil level dip stick, the oil pan, the oil pump and pick-up tube assembly, and the intermediate drive shaft. Re-

move the cap from the connecting rod to which new bearings are to be installed and remove the bearing insert. Push the piston up in the cylinder, then remove the bearing insert from the connecting rod. Clean the crankshaft journals, the cap, and the upper half of the bearing bore.

2. Install the new bearings in the connecting rod and cap. Pull the connecting rod assembly down firmly on the crankshaft journal. Place a piece of Plastigage on the lower bearing surface, the full width of the cap and about  $\frac{1}{4}$  inch off center. Install the cap and tighten the connecting rod nuts to 50-55 foot-pounds torque. **Do not turn the crankshaft while the Plastigage is in place.**

3. Remove the cap, then using the Plastigage scale check the width of the Plastigage at the widest point in order to get the minimum clearance. Check the Plastigage at the narrowest point in order to get the maximum clearance. The difference between the two readings is the taper.

If the clearance is less than the specified limits, try two red bearing halves or a combination of red and blue depending upon the condition. If the standard bearings do not bring the clearance within the desired limits, refinish the crankshaft journal, then install undersize bearings.

After the bearing clearance has been checked and found to be satisfactory, apply a light coat of engine oil to the journal and bearings, then install the connecting rod cap. Tighten the nuts to 50-55 foot-pounds torque.

4. Repeat the procedure for the remaining connecting rods that require new bearings.

5. After all the bearings that required replacement have been replaced, install the intermediate drive shaft, oil pump, and inlet tube and screen assembly. Install the oil pan. Fill the crankcase.

6. Operate the engine at fast idle and check for oil pressure and oil leaks.

**100% SATISFACTION GUARANTEED**

**BUY IT NOW!**

**Click Here To Order**

PayPal   American Express   Discover   MasterCard   VISA

## 9 OIL PAN AND PUMP, OIL FILTER, AND OIL COOLER

### OIL PAN AND PUMP

#### REMOVAL

Drain the oil from the crankcase and remove the oil level dip stick. Remove the oil pan retaining screws and remove the oil pan and discard the gasket.

If the oil pump is to be removed, remove the oil pump and pick-up tube retaining screws and remove the oil pump and pick-up tube assembly. Discard the oil pump gasket. Remove the intermediate drive shaft from the engine.

#### OIL PUMP DISASSEMBLY

1. Remove the oil pick-up tube and screen assembly from the oil pump and discard the gasket. Remove the oil screen retaining wire and remove the screen.

2. Remove the cover retaining screws, then remove the cover. Remove the inner rotor and shaft assembly, then remove the outer race.

3. Insert a self threading sheet metal screw of the proper diameter into the oil pressure relief valve chamber cap and pull the cap out of the chamber. Remove the spring and plunger.

#### OIL PUMP ASSEMBLY

The oil pump assembly is shown in Fig. 52.

1. Remove the old gasket from the oil pump and pick-up tube mounting pads. Clean and oil all parts thoroughly. Install the oil pressure relief valve plunger, spring, gasket, and new cap.

2. Install the outer race, and the inner rotor and shaft assembly. **The inner rotor and shaft, and the outer race are serviced as an assembly. One part should not be replaced without replacing the other.** Install the cover and tighten the cover retaining screws to 10-13 foot-pounds torque. Install the screen and retaining wire in the pick-up tube. Position a new gasket and the oil pick-up tube on the oil pump and install the retaining bolts.

#### INSTALLATION

1. Insert the oil pump drive shaft into the oil pump. Position a new gasket on the pump housing and install the oil pump, shaft, and pick-up tube as an assembly (Fig. 53). **Do not attempt to force the pump into position if it will not seat readily. The drive shaft hex may be misaligned with the distributor shaft. To align,**

**rotate the intermediate shaft into a new position.** Tighten the oil pump retaining screws to 12-15 foot-pounds torque.

2. Remove old gasket sealer from the oil pan and block gasket surfaces. Position a new gasket on the oil pan. Hold the oil pan in place against the cylinder block and install two of the retaining screws on each side of the pan. Install the remaining screws and tighten them from the center outward to 12-15 foot-pounds torque.

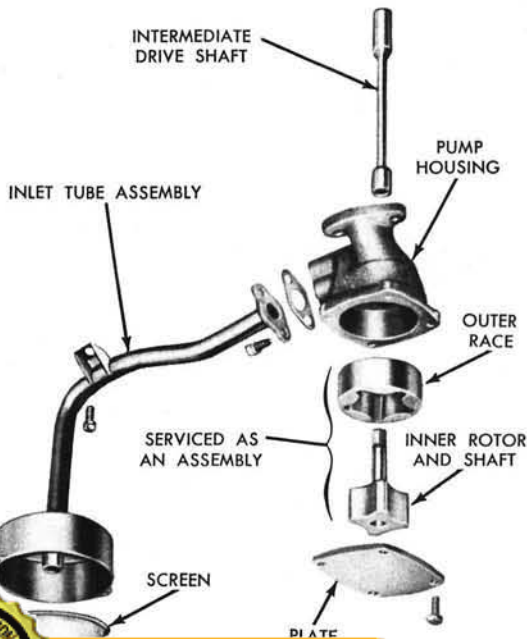
3. Fill the crankcase and install the oil level dip stick. Operate the engine and check for oil leaks.

### OIL FILTER REPLACEMENT

The oil filter assembly is shown in Fig. 54.

1. Place a drip pan under the filter. Remove the filter center bolt, then remove the filter assembly and gasket.

2. Remove the filter element, neoprene gasket, spring and retainer. Remove the center bolt from the container and the fiber gasket from the bolt. Discard the filter element and all gaskets. Wash all parts in solvent. Make sure all the openings in the center bolt are clean.



1714-A

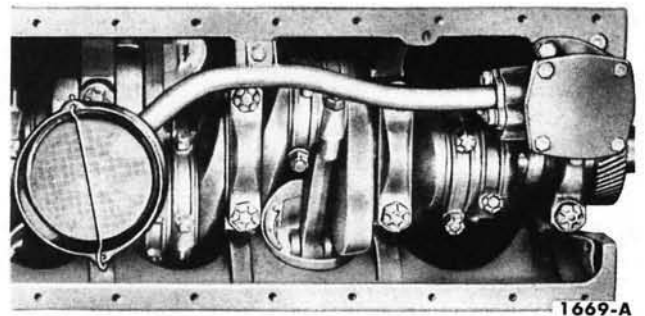
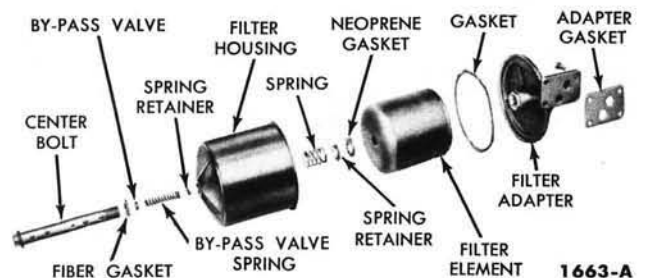


FIG. 53—Oil Pump and Pick-Up Tube Installed



1663-A

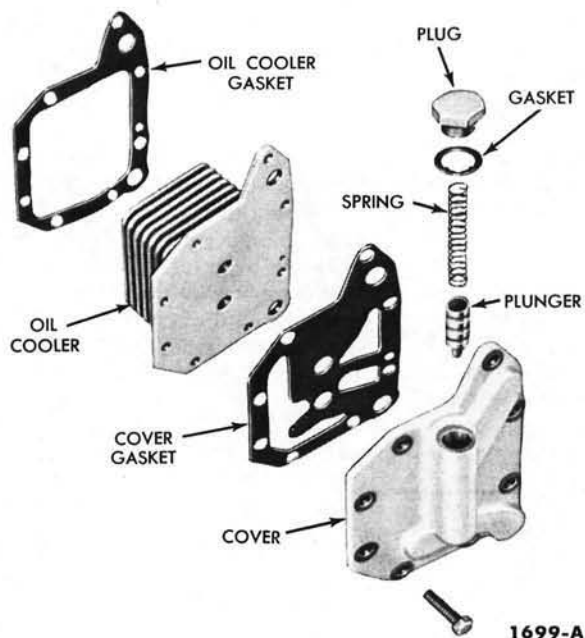
FIG. 54—Oil Filter Assembly

**100% SATISFACTION GUARANTEED**

**BUY IT NOW!**

**Click Here To Order**

PayPal, American Express, Discover, MasterCard, VISA



**FIG. 55—Oil Cooler Assembly**

3. Install a new fiber gasket on the center bolt, then place the bolt through the filter container. Install the spring and retainer assembly on the bolt, making sure the retainer tangs are engaged in the spring. In-

stall a new neoprene gasket and a new filter element over the center bolt.

4. Clean the filter adapter recess, then install a new gasket. Place the filter assembly in position, and thread

the center bolt into the adapter finger tight. Rotate the filter assembly slightly, in each direction, to make sure the gasket is seated evenly. Tighten the center bolt to 45-50 foot-pounds torque. **Do not overtighten the center bolt.**

5. Refill the crankcase with oil as necessary, then operate the engine at fast idle, and check for leaks. If oil leaks are evident, perform the necessary repairs to correct the leakage.

### OIL COOLER REMOVAL

Drain the cooling system. Remove the oil cooler retaining screws, then remove the cover, gasket, oil cooler, and gasket. Remove the relief valve plug and gasket, then remove the spring and plunger. The oil cooler assembly is shown in Fig. 55.

### INSTALLATION

Install the relief valve plunger (with the open chamber up), spring, gasket, and plug in the cover. Place a new oil cooler gasket with sealer on both sides on the block. Position the oil cooler in the block. Place a new cover gasket on the cover with sealer on both sides and install the cover, then tighten the cover bolts to 12-15 foot-pounds torque. Fill and bleed the cooling system.

## 10 EXHAUST SYSTEM

The following procedures apply to either a right or left installation.

### MUFFLER INLET PIPE REPLACEMENT

1. Working from underneath the truck, disconnect the muffler inlet pipe from the exhaust manifold. Loosen the inlet pipe to muffler clamp retaining bolt. Remove the inlet pipe from the muffler and exhaust manifold.

2. Clean all the old gasket material from the exhaust manifold, then install a new gasket over the exhaust manifold studs. Position the new inlet

pipe in the muffler and over the exhaust manifold studs. Install the retaining nuts and lockwashers on the exhaust manifolds and tighten the nuts to 23-28 foot-pounds torque. Tighten the inlet pipe to muffler clamp.

### MUFFLER REPLACEMENT

1. Loosen all muffler outlet pipe clamps, then separate the muffler and outlet pipe by sliding the outlet pipe to the rear. Loosen the muffler inlet pipe to muffler clamp, then separate the muffler from the inlet pipe and remove the muffler.

2. Position the new muffler on the inlet pipe. Slide the outlet pipe forward on the muffler. Align the muffler. Tighten the muffler inlet pipe clamp and all the outlet pipe clamps.

### OUTLET PIPE REPLACEMENT

1. Disconnect the outlet pipe clamps and separate the outlet pipe from the muffler by sliding the outlet pipe to the rear. Remove the outlet pipe.

2. Slide the clamps on the new outlet pipe and slide the outlet pipe on the muffler. Connect all the outlet pipe clamps.

**100% SATISFACTION GUARANTEED**

**BUY IT NOW!**

**Click Here To Order**

PayPal   American Express   Discover   MasterCard   VISA

## PART

## 1-5

## SPECIFICATIONS

NOTE: All specifications are given in inches unless otherwise noted.

## GENERAL

ENGINE MODELS AND PISTON DISPLACEMENT (Cubic Inches)	
223 Six.....	223
V-8 MD (Medium Duty).....	292
HD (Heavy Duty).....	292, 302, and 332
SD (Super Duty).....	401, 477, and 534

BORE AND STROKE	
223.....	3.625 x 3.60
292.....	3.75 x 3.30
302.....	3.625 x 3.66
332.....	3.80 x 3.66
401.....	4.125 x 3.75
477.....	4.50 x 3.75
534.....	4.50 x 4.20

COMPRESSION RATIO	
223 Six.....	8.1:1
292 HD V-8.....	7.6:1
292 MD V-8.....	7.9:1
302, 332 HD V-8; 401, 477, 534 SD V-8.....	7.5:1

COMPRESSION PRESSURE—Sea Level @ Cranking Speed	
223, 292, and 302.....	150 ± 10
332.....	140 ± 10
401, 477, and 534.....	150 ± 20

TAXABLE HORSEPOWER	
223.....	31.50
292.....	44.60
302.....	42.05
332.....	46.20
401.....	54.00
477 and 534.....	65.00

BRAKE HORSEPOWER @ Specified Rpm	
223 Six.....	139 @ 4200
292 MD V-8.....	186 @ 4000
292 HD V-8.....	187 @ 3800
302 HD V-8.....	196 @ 3800
332 HD V-8.....	212 @ 3800
401 SD V-8.....	226 @ 3800
477 SD V-8.....	260 @ 3600
534 SD V-8.....	277 @ 3400

TORQUE—(FOOT-POUNDS) @ Specified RPM	
223 Six.....	208 @ 2000-2600
292 MD V-8.....	269 @ 2200-2700
292 HD V-8.....	270 @ 2300-2900
302 MD V-8.....	299 @ 2500
332 MD V-8.....	328 @ 2500
401 SD V-8.....	380-2300
477 SD V-8.....	300-2300
534 SD V-8.....	300-2300

FIRING ORDER	
223.....	1-3-6-2-4
All other engines.....	1-3-7-2

VALVE ARRANGEMENT (Front to Rear)	
223.....	E-I-I-E-I-E-E-I-E-I-E
292, 302, and 332.....	E-I-I-E-E-I-I-E
401, 477 and 534.....	E-I-E-I-E-I-E

ENGINE IDLE RPM*	
Manual-Shift and Transmatic Transmissions.	
All Engines.....	475-500
Fordomatic Transmission (Drive Range)	
All Engines.....	450

\*Engine idle speed can be varied to suit operating conditions.

ENGINE IDLE MANIFOLD VACUUM—Inches of Mercury @ Specified Engine Neutral Idle rpm (SEA LEVEL)	
223.....	18-19
292.....	19-20
302 and 332.....	18-19
401.....	16-17
477 and 534.....	17-18

INITIAL IGNITION TIMING (B.T.D.C.)	
223 and 292 MD V-8.....	4°
All HD and SD V-8*	
With regular fuel of 85-88 octane.....	4°
With regular fuel of 88-90 octane.....	6°
With regular fuel of 90-92 octane.....	8°
With regular fuel of 92 octane or more or premium fuel.....	10°

\*All octane numbers obtained through the research method.

OIL CAPACITY	
223, 292 MD V-8.....	5 quarts*
292 HD V-8.....	6 quarts*
302 and 332.....	8 quarts*
401, 477, and 534.....	9 quarts**

\*Add one quart when changing oil filter.  
\*\*Add 2 quarts when changing oil filter.

OIL PRESSURE—(Psi) hot @ 2000 rpm	
223 and 292.....	35-50
302 and 332.....	45-55
401, 477, 534.....	35-65

RECOMMENDED OIL VISCOSITY @ specified ambient temperature:	
Above +100°F.....	SAE 40
+32°F to +100°F.....	SAE 30
+10°F to +32°F.....	SAE 20-20W
+10°F to -10°F.....	SAE 10W
Below -10°F.....	SAE 5W

RECOMMENDED MINIMUM A.P.I. CLASSIFICATION OF ENGINE LUBRICATING OILS	
223, 292, 302, and 332.....	MS*
401, 447, and 534.....	MS-S1

\*For extreme heavy duty operation: MS-DG or MS-S1.



**BUY IT NOW!**

Click Here To Order



**CYLINDER HEAD**

**GASKET SURFACE FLATNESS**

.002 inch in any 6 inches or .004 inch overall

**VALVE GUIDE BORE DIAMETER—Standard**

**Intake**

223 and 292.....0.3433-0.3440  
 302 and 332.....0.3728-0.3735  
 401, 477, and 534.....0.4368-0.4375

**Exhaust**

223 and 292 MD.....0.3433-0.3440  
 All HD and SD Engines.....0.4368-0.4375

**VALVE SEAT WIDTH**

**Intake**

223 and 292.....0.060-0.080  
 302 and 332.....0.070-0.085  
 401, 477, and 534.....0.090-0.105

**Exhaust**

223 and 292.....0.070-0.090  
 302 and 332.....0.089-0.112  
 401, 477, and 534.....0.100-0.115

**VALVE SEAT ANGLE**

All Engines (Intake and Exhaust).....45°

**VALVE SEAT RUNOUT**

Maximum.....0.002  
 Wear Limit.....0.0025

**VALVE SEAT INSERT BORE DIAMETER**

**Standard**

**INTAKE**

302 and 332.....2.1215-2.1225  
 401, 477, and 534.....2.2165-2.2175

**EXHAUST**

292, 302, and 332 HD.....1.6245-1.6255  
 401, 477, and 534.....1.7405-1.7415

**0.020 Oversize**

**INTAKE**

302 and 332.....2.1415-2.1425  
 401, 477, and 534.....2.2365-2.2375

**EXHAUST**

292, 302, and 332 HD.....1.6445-1.6455  
 401, 477, and 534.....1.7605-1.7615

**VALVE SEAT INSERT DIAMETER**

**Standard**

**INTAKE**

302 and 332.....2.1245-2.1255  
 401, 477, and 534.....2.2195-2.2205

**EXHAUST**

292, 302, and 332 HD.....1.6275-1.6285  
 401, 477, and 534.....1.7435-1.7445

**0.020 Oversize**

**INTAKE**

302 and 332.....2.1445-2.1455  
 401, 477, and 534.....2.2395-2.2405

**EXHAUST**

292, 302, and 332 HD.....1.6475-1.6485  
 401, 477, and 534.....1.7635-1.7645

**VALVE MECHANISM**

**VALVE LASH**

**Cold**

**INTAKE**

223 Six and 292.....0.019  
 302, 332, 401, 477, and 534.....0.020

**EXHAUST**

223 Six.....0.019  
 292.....0.019  
 302, 332, 401, 477, and 534.....0.022

**Hot**

**INTAKE & EXHAUST**

223.....0.019  
 292.....0.018  
 302, 332, 401, 477 and 534.....0.020

**VALVE STEM DIAMETER**

**Standard**

**INTAKE**

223 and 292.....0.3416-0.3423  
 302 and 332.....0.3711-0.3718  
 401, 477, and 534.....0.4351-0.4358

**EXHAUST**

223 and 292 MD.....0.3403-0.3410  
 All Other Engines.....0.4343-0.4350

**0.003 Oversize**

**INTAKE**

223 and 292.....0.3446-0.3453  
 302 and 332.....0.3741-0.3748  
 401, 477, and 534.....0.4381-0.4388

**EXHAUST**

223 and 292 MD.....0.3433-0.3440  
 292 HD, 302 and 332 HD.....0.4373-0.4380  
 401, 477, and 534.....0.4370-0.4380

**0.015 Oversize**

**INTAKE**

223 and 292.....0.3566-0.3573  
 302 and 332.....0.3861-0.3868  
 401, 477, and 534.....0.4501-0.4508

**EXHAUST**

223 and 292 MD.....0.3553-0.3560  
 292 DH, 302 and 332 HD.....0.4493-0.4500  
 401, 477, and 534.....0.4490-0.4500

**0.030 Oversize**

**INTAKE**

223 and 292.....0.3716-0.3723  
 302 and 332.....0.4011-0.4018  
 401, 477, and 534.....0.4651-0.4658

**EXHAUST**

223 and 292 MD.....0.3703-0.3710  
 292 DH, 302 and 332 HD.....0.4643-0.4650  
 401, 477, and 534.....0.4640-0.4650

**VALVE STEM TO VALVE GUIDE CLEARANCE**

**Intake**

401, 477, and 534...0.026-0.004—Wear Limit 0.0045  
 All Other Engines..0.0010-.0024—Wear Limit 0.0045

**Exhaust**

223 and 292.....0.0023-.0037—Wear Limit 0.0065\*  
 302 and 332.....0.0018-.0032—Wear Limit 0.0055  
 401, 477, and 534...0.026-0.004—Wear Limit 0.0055

\*Wear Limit 0.0055—292 HD.



**BUY IT NOW!**

**Click Here To Order**



**VALVE MECHANISM (Cont.)**

<b>VALVE HEAD DIAMETER</b>	
<b>Intake</b>	
223.....	1.775-1.785
292, 302, and 332.....	1.920-1.930
401, 477, and 534.....	2.015-2.025
<b>Exhaust</b>	
401, 477, and 534.....	1.630-1.640
All Other Engines.....	1.505-1.515

<b>VALVE FACE RUNOUT</b>	
<b>Intake</b>	
401, 477, and 534.....	0.002 —Wear Limit 0.0025
Other Engines.....	0.0015—Wear Limit 0.0020
<b>Exhaust</b>	
All Engines.....	0.0015—Wear Limit 0.0020

<b>INTAKE VALVE (OPENS) TAPPET LIFT @ DEGREES B.T.D.C.</b>	
223.....	0.016 @ 17°
292 MD.....	0.016 @ 12°
292 HD.....	0.015 @ 18°
302 and 332.....	0.017 @ 22°
401, 477, and 534.....	0.0175 @ 18°

<b>INTAKE VALVE (CLOSES) TAPPET LIFT @ DEGREES A.B.D.C.</b>	
223.....	0.019 @ 53°
292 MD.....	0.019 @ 54°
292 HD.....	0.015 @ 58°
302 and 332.....	0.019 @ 62°
401, 477, and 534.....	0.0195 @ 58°

<b>EXHAUST VALVE (OPENS) TAPPET LIFT @ DEGREES B.B.D.C.</b>	
223.....	0.016 @ 61°
292 MD.....	0.015 @ 58°
292 HD.....	0.013 @ 66°
302 and 332.....	0.017 @ 52°
401, 477, and 534.....	0.0175 @ 56°

<b>EXHAUST VALVE (CLOSES) TAPPET LIFT @ DEGREES A.T.D.C.</b>	
223.....	0.019 @ 9°
292 MD.....	0.018 @ 8°
292 HD.....	0.016 @ 10°
302 and 332.....	0.019 @ 24°
401, 477, and 534.....	0.0195 @ 20°

<b>VALVE SPRING FREE LENGTH (approximate)</b>	
401, 477, and 534.....	2.07
Other Engines.....	2.09

<b>VALVE SPRING OUT OF SQUARE (maximum)</b>	
401, 477, and 534.....	0.072
Other Engines.....	0.062

<b>VALVE SPRING PRESSURE (LBS.) @ SPECIFIED LENGTH</b>	
<b>Valve Closed</b>	
401, 477, and 534.....	84-89 @ 1.70— Wear Limit 75 @ 1.70
Other Engines.....	71-79 @ 1.78— Wear Limit 64 @ 1.78
<b>Valve Open</b>	
401, 477, and 534.....	178-192 @ 1.28— Wear Limit 160 @ 1.28
Other Engines.....	161-177 @ 1.39— Wear Limit 145 @ 1.39

100% SATISFACTION GUARANTEED

**BUY IT NOW!**

Click Here To Order

86-0.4992

0.8747

**VALVE MECHANISM (Cont.)**

<b>VALVE TAPPET TO TAPPET BORE CLEARANCE</b>	
223 and 292.....	0.0008-0.0024—Wear Limit 0.0055
302, 332, 401, 477, and 534.....	0.0003-0.0018—Wear Limit 0.0025

<b>ROCKER ARM TO ROCKER SHAFT CLEARANCE</b>	
223 Six.....	0.001-0.003—Wear Limit 0.006
All V-8's.....	0.002-0.004—Wear Limit 0.006

<b>ROCKER ARM SHAFT O.D.</b>	
All Engines.....	0.780-0.781

<b>ROCKER SHAFT BORE DIAMETER</b>	
223 Six.....	0.783-0.787
All V-8's.....	0.783-0.784

**CAMSHAFT, TIMING CHAIN, AND TIMING GEARS**

<b>CAMSHAFT JOURNAL DIAMETER (Standard)</b>	
223 and 292.....	1.9255-1.9265
302 and 332.....	2.1240-2.1247*
401, 477, and 534.....	2.370 -2.371 *

<b>Front Journal</b>	
302, 332, 401, 477, and 534.....	2.474-2.475
*Nos. 2, 3, 4, and 5 journals only.	

<b>CAMSHAFT JOURNAL RUNOUT</b>	
All Engines.....	0.005

<b>CAMSHAFT JOURNAL TO BEARING CLEARANCE</b>	
All Engines.....	0.001-0.003—Wear Limit 0.006

<b>CAMSHAFT JOURNAL OUT-OF-ROUND</b>	
223.....	0.0005—Wear Limit 0.0008
292.....	0.0007—Wear Limit 0.0008
302 and 332.....	0.0005—Wear Limit 0.0008
401, 477, and 534.....	0.0005—Wear Limit 0.0008

<b>CAMSHAFT END PLAY</b>	
All Engines.....	0.003-0.007—Wear Limit 0.012

<b>CAMSHAFT GEAR TO CRANKSHAFT GEAR BACKLASH</b>	
302 and 332.....	0.002-0.004
401, 477, and 534.....	0.001-0.003

<b>TIMING CHAIN DEFLECTION</b>	
223 and 292.....	0.5

<b>CAMSHAFT LOBE LIFT</b>	
<b>Intake</b>	
223.....	0.273
292 MD.....	0.264
292 HD.....	0.272
302 and 332.....	0.244
401, 477, and 534.....	0.275
<b>Exhaust</b>	
223.....	0.273
292 MD.....	0.244
292 HD.....	0.272
302 and 332.....	0.265
401, 477, and 534.....	0.275

<b>MAXIMUM ALLOWABLE LOBE LIFT LOSS</b>	
Intake & Exhaust.....	0.005

**CAMSHAFT BEARINGS**

<b>INSIDE DIAMETER</b>	
223 and 292.....	1.9275-1.9285
302 and 332.....	2.1263-2.1268*
401, 477, and 534.....	2.372 -2.373**



**CAMSHAFT BEARINGS (Cont.)**

<b>LOCATION IN RELATION TO FRONT FACE OF BLOCK CAM BEARING BORE—NO. 1 BEARING ONLY (BELOW)</b>	
223 and 292.....	0.005-0.020
302 and 332.....	0.002-0.020
401, 477, and 534.....	0.037-0.043
*Nos. 2, 3, 4, and 5 bearings only—No. 1 bearing 2.4758-2.4768. **Nos. 2, 3, 4, and 5 bearings only—No. 1 bearing 2.476-2.477.	

**FLYWHEEL**

<b>CONVENTIONAL and OVERDRIVE TRANSMISSION ASSEMBLED FLYWHEEL CLUTCH FACE RUNOUT (MAX.)</b>	
All Engines.....	0.010

**CRANKSHAFT**

<b>MAIN BEARING JOURNAL DIAMETER</b>	
Standard	
223 and 292.....	2.4980-2.4988
302 and 332.....	2.6230-2.6238
401, 477, and 534.....	3.1246-3.1254
<b>MAIN BEARING JOURNAL RUNOUT</b>	
223 Six.....	0.002—Wear Limit 0.004
All V-8's.....	0.001—Wear Limit 0.003
<b>CONNECTING ROD AND MAIN BEARING JOURNALS OUT-OF-ROUND</b>	
All Engines.....	0.00025—Wear Limit 0.0005
<b>CONNECTING ROD AND MAIN BEARING JOURNALS TAPER</b>	
All Engines.....	0.0005—Wear Limit 0.001
<b>THRUST BEARING JOURNAL LENGTH</b>	
223.....	1.359-1.361
292, 302, and 332.....	1.124-1.126
401, 477, and 534.....	1.279-1.281
<b>MAIN BEARING JOURNAL THRUST FACE RUNOUT</b>	
All Engines.....	0.001
<b>CONNECTING ROD JOURNAL DIAMETER</b>	
223.....	2.2980-2.2988
292.....	2.1880-2.1888
302 and 332.....	2.2482-2.2490
401, 477, and 534.....	2.7496-2.7504
<b>CRANKSHAFT FREE END PLAY</b>	
292.....	0.002-0.006—Wear Limit 0.010
All Other Engines.....	0.004-0.008—Wear Limit 0.012
<b>ASSEMBLED FLYWHEEL CLUTCH FACE RUNOUT</b>	
All Engines.....	0.010
<b>ASSEMBLED FLYWHEEL O.D. RUNOUT</b>	
All Engines.....	0.005
<b>ASSEMBLED GEAR FACE RUNOUT</b>	
302, 332, 401, 477, and 534.....	0.005

**CONNECTING ROD**

<b>PISTON PIN BUSHING I.D.</b>	
Standard	
401, 477, and 534.....	1.2201-1.2204
All Other Engines.....	0.9122-0.9125
<b>PISTON PIN BUSHING OUT-OF-ROUND AND TAPER</b>	
401, 477, and 534.....	0.0002
All Other Engines.....	0.0003
<b>BEARING BORE DIAMETER</b>	
223.....	2.4230-2.4238
292.....	2.3120-2.3128
302, 332.....	2.4002-2.4010
401, 477, 534.....	2.9032-2.9040
<b>BEARING BORE OUT-OF-ROUND AND TAPER</b>	
401, 477, and 534.....	0.0002
Other Engines.....	0.0004
<b>CONNECTING ROD LENGTH (Center to center)</b>	
223.....	6.258-6.262
292.....	6.320-6.324
302 and 332.....	7.064-7.066
401, 477, and 534.....	7.739-7.741
<b>CONNECTING ROD</b>	
Twist Total Difference*	
401, 477, and 534.....	0.004
All Other Engines.....	0.012
Bend Total Difference*	
All Engines.....	0.004
*Pin bushing and crankshaft bearing bore must be parallel and in the same vertical plane within the specified total difference at ends of 8-inches-long bar measured 4-inches on each side of rod.	
<b>CONNECTING ROD ASSEMBLY (Assembled to crankshaft)</b>	
Side Clearance	
223.....	0.003-0.009—Wear Limit 0.012
292, 302, and 332....	0.006-0.016—Wear Limit 0.019
401, 477, and 534....	0.006-0.014—Wear Limit 0.019

**CONNECTING ROD BEARINGS**

<b>BEARING TO CRANKSHAFT CLEARANCE</b>	
223.....	0.0004-0.0023—Wear Limit 0.0033
292.....	0.0008-0.0027—Wear Limit 0.0037
302 and 332.....	0.0007-0.0026—Wear Limit 0.0036
401, 477, and 534....	0.0010-0.0029—Wear Limit 0.0039

**PISTON**

<b>PISTON DIAMETER</b>	
Standard (Color Coded Red)	
223 and 302.....	3.6236-3.6242
292.....	3.7486-3.7492
332.....	3.7986-3.7992
401.....	4.1233-4.1239
477 and 534.....	4.4983-4.4989
Standard (Color Coded Blue)	
223 and 302.....	3.6248-3.6254
292.....	3.7498-3.7504
332.....	3.7998-3.8004
401.....	4.1245-4.1251
477 and 534.....	4.4995-4.5001
0.003 Oversize	
223 and 302.....	3.6260-3.6266
292.....	3.7510-3.7516
332.....	3.8010-3.8016
401.....	4.1257-4.1263
477 and 534.....	4.5007-4.5013
<b>PISTON TO BORE CLEARANCE (Bottom of skirt)</b>	
401, 477, and 534....	0.0011-0.0029—Wear Limit 0.005
All Other Engines....	0.0008-0.0026—Wear Limit 0.005



BUY IT NOW!

Click Here To Order







Limit 0.0035  
Limit 0.0042  
Limit 0.0043  
Limit 0.0046

**PISTON PIN**

**PISTON PIN DIAMETER**

<b>Standard (Color Coded Green)</b>	
401, 477, and 534.....	1.2198-1.2201
Other Engines.....	0.9120-0.9123
<b>0.001 Oversize (Color Coded Blue)</b>	
401, 477, and 534.....	1.2208-1.2211
All Other Engines.....	0.9130-0.9133
<b>0.002 Oversize (Color Coded Yellow)</b>	
401, 477, and 534.....	1.2218-1.2221
All Other Engines.....	0.9140-0.9143

**PISTON PIN LENGTH**

223 and 292.....	3.016-3.030
302.....	3.014-3.028
332.....	3.162-3.176
401.....	3.335-3.350
477 and 534.....	3.840-3.855

**PISTON PIN TO PISTON CLEARANCE (LOOSE)**

401, 477, and 534..	0.0003-0.0005—Wear Limit 0.001
Other Engines.....	0.0001-0.0003—Wear Limit 0.0008

**PISTON PIN TO CONNECTING ROD BUSHING CLEARANCE (LOOSE)**

223 and 292.....	0.0001-0.0003
All Other Engines.....	0.0002-0.0004
<b>Wear Limit</b>	
401, 477, and 534.....	0.001
All Other Engines.....	0.0008

**PISTON RINGS**

**RING WIDTH**

<b>Compression Ring</b>	
292.....	0.0775-0.0780
All Other Engines.....	0.0930-0.0935
<b>Oil Ring*</b>	
302 and 332.....	0.1545-0.1550**
401, 477, and 534.....	0.1865-0.1860

\*Two rings used per groove.  
\*\*Width specified is for one ring.

**SIDE CLEARANCE**

<b>Compression Ring</b>	
223 and 292.....	0.0020-0.0035—Wear Limit 0.006
302 and 332.....	0.0025-0.0040—Wear Limit 0.006
401, 477, and 534..	0.0030-0.0045—Wear Limit 0.006
<b>Oil Ring</b>	
223 and 292.....	Snug
302 and 332.....	0.003-0.005—Wear Limit 0.007
401, 477, and 534..	0.0015-0.0030—Wear Limit 0.005

**RING GAP WIDTH**

<b>Compression Ring (Standard Bore)</b>	
401, 477, and 534.....	0.013-0.023
Other Engines.....	0.010-0.027
401, 477, and 534.....	0.062*
Other Engines.....	0.027
401, 477, and 534.....	0.028

\*Standard

**CYLINDER BLOCK**

**CYLINDER BORE DIAMETER (Standard spreads for 8 grades).**

223.....	3.6250-3.6274
292.....	3.7500-3.7524
302.....	3.6250-3.6274
332.....	3.8000-3.8024
401.....	4.1250-4.1274
477 and 534.....	4.5000-4.5024

**CYLINDER BORE OUT-OF-ROUND (Maximum)**

All Engines.....	0.0005—Wear Limit 0.005
------------------	-------------------------

**CYLINDER BORE TAPER**

All Engines.....	0.001—Wear Limit 0.008
------------------	------------------------

**HEAD GASKET SURFACE FLATNESS**

All Engines.....	.002 inch in any 6 inches or .004 inch overall
------------------	--

**OIL PUMP (Gear Type)**

**RELIEF VALVE SPRING TENSION (LBS.) @ SPECIFIED LENGTH**

223.....	9.76-9.84 @ 1.56
----------	------------------

**RELIEF VALVE CLEARANCE**

223.....	0.002-0.004
----------	-------------

**DRIVE SHAFT TO HOUSING BEARING CLEARANCE**

223.....	0.0015-0.0029
----------	---------------

**GEAR END CLEARANCE (PUMP ASSEMBLED)**

223.....	0.003-0.006
----------	-------------

**DRIVEN GEAR TO SHAFT CLEARANCE**

223.....	0.001-0.002
----------	-------------

**GEAR TO HOUSING—RADIAL CLEARANCE**

223.....	0.0015-0.0060
----------	---------------

**OIL PUMP (Rotor Type)**

**RELIEF VALVE SPRING TENSION (LBS.) @ SPECIFIED LENGTH**

292.....	8.7- 9.9 @ 1.71
302 and 332.....	5.7- 6.5 @ 1.33
401, 477, and 534.....	10.7-11.9 @ 1.07

**RELIEF VALVE CLEARANCE**

All Engines.....	0.0015-0.0029
------------------	---------------

**DRIVE SHAFT TO HOUSING BEARING CLEARANCE**

292, 302, and 332.....	0.0015-0.0029
401, 477, and 534.....	0.0019-0.0025

**ROTOR ASSEMBLY END CLEARANCE (PUMP ASSEMBLED)**

All V-8 Engines.....	0.0010-0.0035
----------------------	---------------

**OUTER RACE TO HOUSING (Radial clearance)**

292, 302, and 332.....	0.006-0.009
401, 477, and 534.....	0.006-0.011

**DRIVE SHAFT LENGTH (ROTOR ASSEMBLY FACE TO SHAFT END)**

292, 302 and 332.....	3.36-3.38
401, 477, and 534.....	3.26-3.38

**TORQUE LIMITS (Foot-Pounds)**

<b>MAIN BEARING CAP BOLTS (Oiled threads)</b>	
223 and 292.....	95-105
302 and 332.....	120-130
401, 477, and 534.....	150-164
<b>CYLINDER HEAD BOLTS (Oiled threads)</b>	
223 and 292.....	75
302 and 332.....	110
401, 477, and 534.....	130-150
<b>OIL PAN TO CYLINDER BLOCK</b>	
All Engines.....	12-15
<b>MANIFOLD TO CYLINDER HEAD</b>	
Intake and Exhaust.....	23-38
<b>FLYWHEEL TO CRANKSHAFT</b>	
401, 477 and 534.....	100-110
Other Engines.....	75- 85
<b>OIL PUMP TO CYLINDER BLOCK</b>	
223 Six.....	30-35
All V-8's.....	12-15
<b>OIL PUMP COVER PLATE</b>	
401, 477 and 534.....	10-13
All Other Engines.....	12-15
<b>OIL FILTER ADAPTER TO CYLINDER BLOCK</b>	
302 and 332.....	20-25
401, 477, and 534.....	12-15
<b>OIL FILTER TO ADAPTER OR CYLINDER BLOCK</b>	
302 and 332.....	20-25
401, 477, and 534.....	45-50
<b>OIL COOLER TO CYLINDER BLOCK</b>	
401, 477, and 534.....	12-15
<b>CYLINDER FRONT COVER</b>	
223.....	6-9
292.....	$\frac{3}{8}$ inch bolt—23-28
	$\frac{5}{16}$ inch bolt—12-15
302, 332, 401, 477, and 534.....	23-28
<b>WATER OUTLET HOUSING</b>	
223, 302, and 332.....	23-28
292.....	12-15
401, 477, and 534.....	30-35
<b>VALVE ROCKER ARM COVER</b>	
401, 477, and 534.....	12-15
All Other Engines.....	2.0-2.5
<b>CAMSHAFT SPROCKET OR GEAR TO CAMSHAFT</b>	
401, 477, and 534.....	12-15
All Other Engines.....	35-45
<b>DAMPER OR PULLEY TO CRANKSHAFT</b>	
223 and 292.....	85-95
302, 332, 401, 477, and 534.....	130-145
<b>CONNECTING ROD NUTS</b>	
401, 477, and 534.....	60-65
All Other Engines.....	45-50

**TORQUE LIMITS (Foot-Pounds) (Cont.)**

<b>CAMSHAFT THRUST PLATE TO BLOCK</b>	
All Engines.....	12-15
<b>VALVE ROCKER SHAFT SUPPORT TO CYLINDER HEAD</b>	
223.....	45-55
292.....	12-15
302 and 332.....	22-25
<b>VALVE ROCKER ARM ADJUSTING SCREW (Self Locking) Minimum torque to rotate</b>	
223, 292, 302, and 332.....	3
<b>VALVE ROCKER ARM ADJUSTING NUT</b>	
401, 477, and 534.....	7-15
<b>VALVE PUSH ROD CHAMBER COVER</b>	
223.....	15-20 (Inch-Pounds)
292, 302, and 332.....	2.0-2.5
401, 477, and 534.....	5 and 10*
	*10 on center end bolts; 5 on side bolts
<b>WATER PUMP TO CYLINDER BLOCK OR FRONT COVER</b>	
223, 302 and 332.....	23-28
292.....	12-15
401, 477 and 534.....	35-40
<b>OIL PICK-UP TUBE TO OIL PUMP</b>	
292, 302, and 332.....	10-12
401, 477 and 534.....	15-20
<b>OIL PICK-UP TUBE TO OIL PAN</b>	
292, 302, and 332.....	28-32
<b>CRANKCASE VENTILATION OUTLET FILTER COVER TO HOUSING</b>	
292.....	3-5
<b>CRANKCASE VENTILATION ADAPTER TO CYLINDER BLOCK</b>	
223.....	8-10
292, 302, and 332.....	12-15
<b>FUEL PUMP TO CYLINDER BLOCK OR CYLINDER FRONT COVER</b>	
223.....	12-15
292.....	23-28
<b>ENGINE GOVERNOR TO CYLINDER BLOCK</b>	
401, 477, and 534.....	23-28
<b>ENGINE FRONT SUPPORT</b>	
<b>Insulator Assembly To Engine Front Mount</b>	
223, 292, 302, and 332.....	45-55 ( $\frac{1}{2}$ -20) 35-45 ( $\frac{7}{16}$ -20)
<b>Engine Front Mounting Bracket To Engine Front Support</b>	
401, 477, and 534.....	45-55 ( $\frac{1}{2}$ -20)
<b>ENGINE REAR SUPPORT</b>	
<b>Insulator To Rear Engine Mount</b>	
401, 477, and 534.....	100-150 ( $\frac{3}{8}$ -18)
All Other Engines.....	70-90 ( $\frac{9}{16}$ -18)
<b>Engine Rear Support To Flywheel Housing</b>	
401, 477, 534.....	90-100 ( $\frac{1}{2}$ -13)

**TORQUE LIMITS FOR VARIOUS SIZE BOLTS**

**CAUTION:** In the event that any of the below limits are in disagreement with any of those listed above, the above limits prevail.

1/4-20	1/4-28	5/16-18	5/16-24	3/8-16	3/8-24
6-9	6-9	12-15	15-18	23-28	30-35
7/16-14	7/16-20	1/2-13	1/2-20	9/16-18	5/8-18
50-55	50-60	60-70	70-80	85-95	130-145



**BUY IT NOW!**

**Click Here To Order**

