

1 9 5 9

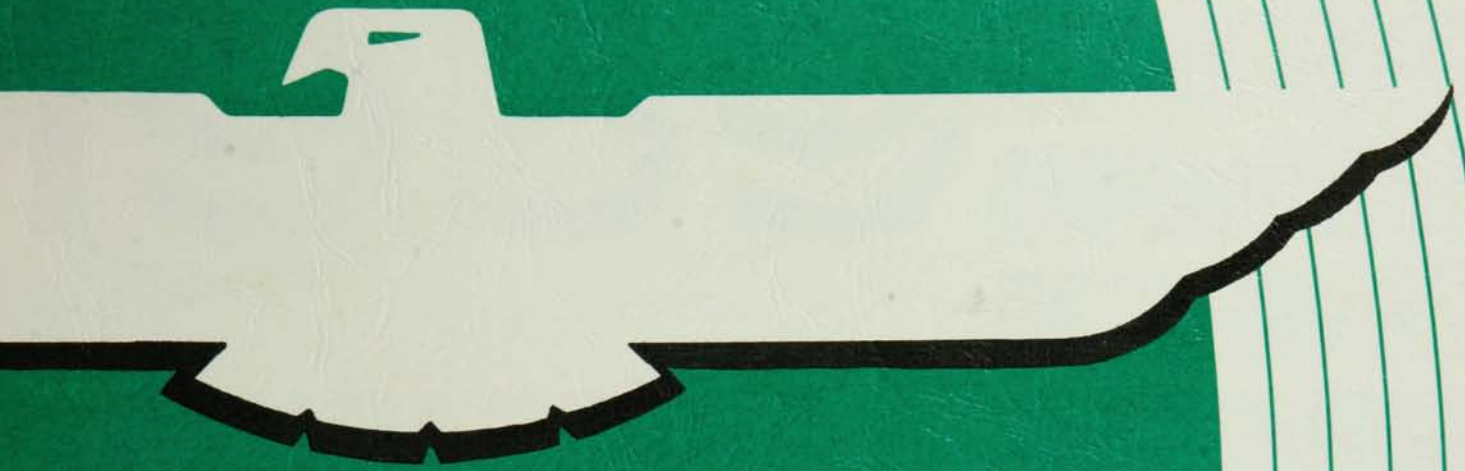

FORD

Thunderbird



**SHOP
MANUAL**

FORD DIVISION COMPANY



BUY IT NOW!

Click Here To Order



PayPal

MasterCard

DISCOVER
NOWUS

MasterCard

VISA

Copyright © 2009, Forel Publishing Company, LLC, Woodbridge, Virginia

All Rights Reserved. No part of this book may be used or reproduced in any manner whatsoever without written permission of Forel Publishing Company, LLC. For information write to Forel Publishing Company, LLC, 3999 Peregrine Ridge Ct., Woodbridge, VA 22192

1959 Ford Thunderbird Shop Manual

EAN: 978-1-60371-009-1

ISBN: 1-60371-009-4

Forel Publishing Company, LLC

3999 Peregrine Ridge Ct.

Woodbridge, VA 22192

Email address: webmaster@ForelPublishing.com

Website: <http://www.ForelPublishing.com>



This publication contains material that is reproduced and distributed under a license from Ford Motor Company. No further reproduction or distribution of the Ford Motor Company material is allowed without the express written permission of Ford Motor Company.

Note from the Editor

This product was created from the original Ford Motor Company's publication. Every effort has been made to use the original scanned images, however, due to the condition of the material; some pages have been modified to remove imperfections.

Disclaimer

Although every effort was made to ensure the accuracy of this book, no representations or warranties of any kind are made concerning the accuracy, completeness or suitability of the information, either expressed or implied. As a result, the information contained within this book should be used as general information only. The author and Forel Publishing Company, LLC shall have neither liability nor responsibility to any person or entity with respect to any loss or damage caused, or alleged to be caused, directly or indirectly by the information contained in this book. Further, the publisher and author are not engaged in rendering legal or other professional services. If legal, mechanical, electrical, or other expert assistance is required, the professional should be sought.



1959

THUNDERBIRD

SHOP MANUAL



SERVICE DEPARTMENT
BUY IT NOW!
SION
MPANY

[Click Here To Order](#)

PayPal

Discover
Cards

Discover
Novus

MasterCard

VISA

NY, DEARBORN, MICHIGAN

Company's Permission

INDEX

GROUP

ENGINES AND EXHAUST SYSTEM

1

IGNITION, FUEL, AND
COOLING SYSTEMS

2

CLUTCH AND MANUAL-SHIFT
TRANSMISSIONS

3

CRUISE-O-MATIC TRANSMISSIONS

4

REAR AXLE AND DRIVE LINE

5

WHEELS, TIRES, CHASSIS
SUSPENSION, AND UNDERBODY

6

STEERING

7

BRAKES

8

GENERATING AND STARTING
SYSTEMS

9

LIGHTS, INSTRUMENTS, AND
ACCESSORIES

10

BODY MAINTENANCE AND REPAIR

11

DOORS, DECK LID, AND FRONT
SHEET METAL

12

INTERIOR TRIM, SEATS, AND
WINDOWS

13

CONVERTIBLE TOP

14

MAINTENANCE, LUBRICATION, AND
SPECIAL TOOLS

15

FOREWORD

This manual provides information for the proper servicing of the 1959 Thunderbird. The descriptions and specifications contained in this manual were in effect at the time the manual was approved for printing.

The Ford Division of Ford Motor Company reserves the right to discontinue models at any time, or change specifications or design, without notice and without incurring obligation.

**SERVICE DEPARTMENT
FORD DIVISION
FORD MOTOR COMPANY**



1959 THUNDERBIRD SHOP MANUAL

GROUP I

ENGINES AND EXHAUST SYSTEM

	PAGE
PART 1-1 GENERAL ENGINE SERVICE.....	1-2
PART 1-2 THUNDERBIRD 352 SPECIAL V-8.....	1-23
PART 1-3 THUNDERBIRD 430 SPECIAL V-8.....	1-48
PART 1-4 EXHAUST SYSTEM.....	1-72
PART 1-5 SPECIFICATIONS.....	1-74



BUY IT NOW!

Click Here To Order

PayPal

Discover
Cards

DISCOVER
NOWUS

MasterCard

VISA

PART

1-1

GENERAL ENGINE SERVICE

The service procedures in this Part apply to both the Thunderbird 352 and 430 Special V-8 engines. The cleaning, inspection, and reconditioning of the various component parts apply after the parts have been removed from the engine, or in the case of a complete overhaul, after the engine has been disassembled.

For removal, disassembly, assembly, and installation procedures, refer to Part 1-2 or 1-3.

Section	Page	Section	Page
1 Engine Trouble Diagnosis.	1-2	Exhaust Manifold	1-11
2 Tune-Up	1-8	Valve Rocker Arm Shaft Assembly	1-12
3 Tests and Adjustments (Engine Installed)	1-9	Push Rods	1-12
Camshaft Lobe Lift	1-9	Cylinder Heads	1-12
Valve Timing	1-9	Valves	1-13
Valve Clearance	1-9	Hydraulic Valve Lifters.	1-15
Manifold Vacuum Test.	1-10	Timing Chain	1-15
Compression Test	1-10	Camshaft and Bearings.	1-15
4 Cleaning, Inspection, and Reconditioning	1-11	Crankshaft	1-15
Intake Manifold	1-11	Connecting Rods	1-16
		Pistons, Pins, and Rings.	1-16

Section	Page
Main and Connecting Rod Bearings	1-18
Flywheel—Manual-Shift Transmissions	1-21
Cylinder Block	1-21
Oil Pan and Oil Pump (and Vacuum Booster—430 Engine)	1-22

1 ENGINE TROUBLE DIAGNOSIS

Poor engine performance can be caused by the need of a general engine tune-up, by gradual wear of engine parts, or by a sudden parts failure. A good trouble diagnosis will indicate the need of a complete engine tune-up, individual adjustments, part(s) replacement or overhaul, or the need of a complete engine overhaul.

Engine performance complaints usually fall under one of the basic headings listed in the "Engine Trouble Diagnosis Guide."

In addition, the "Engine Trouble Diagnosis Guide," lists procedures and checks to be performed to help isolate the cause of the trouble. When a particular trouble can not be traced to a definite cause by a simple check, the possible items that could be at fault are listed in the order of their probable occurrence. Therefore, in most cases, the items should be checked in the order listed. For example, under Poor Acceleration, the ignition system is

listed as a probable cause of the trouble. All the ignition system items that affect acceleration are listed. These items should all be checked before proceeding to the next probable cause listed in the guide.

For the checking procedures and corrections to be made in the various systems, refer to that part of the manual which covers the system in detail. For example, refer to Part 2-1 for ignition system items.

ENGINE TROUBLE DIAGNOSIS GUIDE

<p>ENGINE WILL NOT CRANK</p>	<p>The cause of this trouble is usually in the starting system. If the starting system is not at fault, check for a hydrostatic lock or a seized engine. Remove the spark plugs, then attempt to crank the engine with the starter. If the</p>	<p>engine cranks, it indicates that water is leaking into the cylinders. Remove the cylinder head(s) and inspect the gasket(s) and/or head(s) for cracks. Also examine the cylinder block for cracks.</p>
<p>Check the fuel supply. If there is sufficient fuel in the tank, the cause of the trouble probably lies in either the ignition or the fuel system. To determine which system is at fault, remove the ignition wire from the spark plug. Insert a piece of</p>	<p>proper sized metal rod in the insulator so that it protrudes from the insulator. With the ignition on and the starter cranking the engine, hold the end of the rod approximately 3/16 inch from the cylinder block.</p>	



BUY IT NOW!

Click Here To Order







ENGINE TROUBLE DIAGNOSIS GUIDE (Cont.)

**ENGINE CRANKS
NORMALLY, BUT WILL
NOT START (CONT.)****NO SPARK OR A WEAK
SPARK AT THE
SPARK PLUGS**

The cause of the trouble is in the ignition system.

To determine if the cause of the trouble is in the primary or the secondary circuit, remove the coil high tension lead from the top of the distributor and hold it approximately 3/16 inch from the cylinder head, then with the ignition on and the engine turning over, check for a spark.

If the spark at the coil high tension lead is good, the cause of the trouble is probably in the distributor cap, rotor, or the spark plug wires.

If there is no spark or a weak spark at the coil high tension lead, the cause of the trouble is probably in the primary circuit, coil to distributor high tension lead, or the coil.

**A GOOD SPARK AT
THE SPARK PLUGS**

If the spark is good at the spark plugs, check the spark plugs and the ignition timing. If the spark plugs or the ignition timing are not at fault, check the following items:

FUEL SYSTEM

Check the position of the choke plate. If the engine is warm, the plate should be open. If the plate is not open, the engine will load up due to the excessively rich mixture and will not start. If the engine is cold, the plate should be closed, if the plate is not operating properly, check the following items:

- The choke linkage for binding.
- The fast idle cam for binding.

Thermostatic spring housing adjustment.

Fast idle speed screw for proper adjustment.

Choke plate valve for proper operation (Ford carburetor).

Fuel Supply at Carburetor. Work the throttle by hand several times. Each time the throttle is actuated fuel should spurt from the accelerating pump discharge nozzles.

If fuel is discharged by the accelerating pump, the engine is probably flooded, or there is water in the fuel system, or an engine mechanical item, such as valves, is at fault.

If fuel is not discharged by the accelerating pump, disconnect the carburetor fuel inlet line at the carburetor. Use a suitable container to catch the fuel. Crank the engine to see if fuel is reaching the carburetor.

If fuel is not reaching the carburetor, check:

The fuel pump.

The carburetor fuel inlet line for obstructions.

The flexible fuel pump inlet line for a collapsed condition.

The fuel tank line to flexible fuel line for obstructions.

The fuel tank vent.

If fuel is reaching the carburetor, check:

The fuel inlet system including, the fuel inlet screen, the fuel inlet needle and seat assembly, and the float assembly.

Check for dirt in the carburetor, not allowing fuel to enter or be discharged from the idle system.

ENGINE

Check the valve timing.

**ENGINE STARTS, BUT
FAILS TO KEEP RUNNING****FUEL SYSTEM**

Idle fuel mixture needle(s) not properly adjusted.

Engine idle speed set too low.

The choke not operating properly.

Float setting incorrect.

Fuel inlet system not operating properly.

Dirt or water in fuel lines or carburetor.

Carburetor icing.

Fuel pump defective.

IGNITION SYSTEM

Breaker points not properly adjusted.

Defective spark plugs.

Open circuit at the resistor.

Leakage in the high tension wiring.

100% SATISFACTION GUARANTEED

BUY IT NOW!

Click Here To Order

PayPal American Express Discover MasterCard VISA

ENGINE TROUBLE DIAGNOSIS GUIDE (Cont.)

ENGINE RUNS, BUT MISSES

Determine if the miss is steady or erratic and at what speed the miss occurs by operating the engine at various speeds under load.

MISSES STEADILY AT ALL SPEEDS

Isolate the miss by operating the engine with one cylinder not firing. This is done by operating the engine with the ignition wire removed from one spark plug at a time, until all cylinders have been checked. Ground the spark plug wire removed.

If the engine speed changes when a particular cylinder is shorted out, that cylinder was delivering power before being shorted out. If no change in the engine operation is evident, the miss was caused by that cylinder not delivering power before being shorted out. Check the:

IGNITION SYSTEM

If the miss is isolated in a particular cylinder, perform a spark test on the ignition lead of the cylinder.

If a good spark does not occur, the trouble is in the secondary circuit of the system, check the:

Spark plug wire.

Distributor cap.

If a good spark occurs, check the spark plug. If the spark plug is not at fault, a mechanical component of the engine is probably at fault.

ENGINE

Perform a compression test to determine which mechanical component of the engine is at fault.

MISSES ERRATICALLY AT ALL SPEEDS**EXHAUST SYSTEM**

Exhaust gas control valve inoperative or sticking (352 engine).

Exhaust system restricted.

IGNITION SYSTEM

Breaker points not properly adjusted.

Defective breaker points, condenser, secondary wiring, coil, or spark plugs.

High tension leakage across the coil, rotor, or distributor cap.

FUEL SYSTEM

Choke not operating properly.

Float setting incorrect.

Fuel inlet system not operating properly.

Dirt or water in fuel lines or carburetor.

COOLING SYSTEM

Check the cooling system for internal leakage and/or for a condition that prevents the engine from reaching normal operating temperature.

ENGINE

Perform a compression test to determine which mechanical component of the engine is at fault.

MISSES AT IDLE ONLY**FUEL SYSTEM**

Idle fuel mixture needles not properly adjusted.

IGNITION SYSTEM

Defective coil, condenser, breaker points, rotor, ignition wiring, or spark plugs.

Excessive play in the distributor shaft.

Worn distributor cam.

VACUUM BOOSTER PUMP

Leaking pump, lines, or fittings.

ENGINE

Perform a compression test to determine which mechanical component of the engine is at fault.

MISSES AT HIGH SPEED ONLY**FUEL SYSTEM**

Power valve clogged or damaged (Ford carburetor).

Vacuummeter not operating properly (Carter carburetor).

Low or erratic fuel pump pressure.

Fuel inlet system not operating properly.

COOLING SYSTEM

Engine overheating.

FUEL SYSTEM

Engine idle speed set too low.
Idle fuel mixture needle(s) not properly adjusted.
Float setting incorrect.

Air leaks between the carburetor and the manifold and/or fittings.

Fuel leakage at the carburetor fuel bowl(s).



BUY IT NOW!

Click Here To Order



ENGINE TROUBLE DIAGNOSIS GUIDE (Cont.)

<p>ROUGH ENGINE IDLE (Cont.)</p>	<p>Idle fuel system air bleeds or fuel passages restricted. Fuel bleeding from the accelerating pump discharge nozzle(s). Throttle plates not closing. Improper secondary throttle plate stop adjustment (Ford carburetor).</p> <p>IGNITION SYSTEM</p> <p>Improperly adjusted or defective breaker points. Fouled or improperly adjusted spark plugs. Incorrect ignition timing. Spark plug misfiring.</p>	<p>EXHAUST SYSTEM</p> <p>Exhaust gas control valve inoperative or sticking (352 engine).</p> <p>VACUUM BOOSTER PUMP</p> <p>Leaking pump, lines, or fittings.</p> <p>ENGINE</p> <p>Loose engine mounting bolts or worn insulator. Cylinder head bolts not properly tightened. Intake manifold seals leaking (352 engine).</p>
<p>POOR ACCELERATION</p>	<p>IGNITION SYSTEM</p> <p>Incorrect ignition timing. Fouled or improperly adjusted spark plugs. Improperly adjusted or defective breaker points. Distributor not advancing properly.</p> <p>FUEL SYSTEM</p> <p>Inoperative accelerating pump inlet. Inoperative accelerating pump discharge ball check. Accelerating pump diaphragm or piston defective. Float setting incorrect. Throttle linkage not properly adjusted. Accelerating pump stroke not properly adjusted.</p>	<p>Leaky power valve, gaskets, or accelerating pump diaphragm or accelerating pump piston. Dirt or corrosion in accelerating system. Distributor vacuum passages in the carburetor blocked.</p> <p>EXHAUST SYSTEM</p> <p>Exhaust gas control valve inoperative or sticking (352 engine).</p> <p>BRAKES</p> <p>Improper adjustment.</p> <p>TRANSMISSION</p> <p>Clutch slippage (manual - shift transmissions). Improper band adjustment (automatic transmissions).</p>
<p>ENGINE DOES NOT DEVELOP FULL POWER, OR HAS POOR HIGH SPEED PERFORMANCE</p>	<p>PRELIMINARY</p> <p>Determine if the trouble exists when the engine is cold, at normal operating temperature, or at all engine temperatures.</p> <p>ENGINE COLD</p> <p>EXHAUST SYSTEM</p> <p>Exhaust gas control valve inoperative or sticking (352 engine).</p> <p>FUEL SYSTEM</p> <p>Clogged or undersize main jets and/or low float setting. Clogged or undersize secondary jets. Power valve clogged or damaged.</p>	<p>Secondary throttle plates not opening. Fuel pump pressure incorrect. Distributor vacuum passage in the carburetor blocked.</p> <p>COOLING SYSTEM</p> <p>Thermostat inoperative or incorrect heat range.</p> <p>ENGINE AT NORMAL OPERATING TEMPERATURE</p> <p>EXHAUST SYSTEM</p> <p>Exhaust gas control valve inoperative or sticking (352 engine).</p> <p>FUEL SYSTEM</p> <p>Same items as for engine cold.</p>

100% SATISFACTION GUARANTEED

BUY IT NOW!

Click Here To Order

PayPal American Express Discover MasterCard VISA

ENGINE TROUBLE DIAGNOSIS GUIDE (Cont.)

<p>ENGINE DOES NOT DEVELOP FULL POWER, OR HAS POOR HIGH SPEED PERFORMANCE (Cont.)</p>	<p>ALL ENGINE TEMPERATURES</p> <p>IGNITION SYSTEM</p> <p>Ignition timing not properly adjusted.</p> <p>Defective coil, condenser, or rotor.</p> <p>Distributor not advancing properly.</p> <p>Excessive play in the distributor shaft.</p> <p>Distributor cam worn.</p> <p>Fouled or improperly adjusted spark plugs or spark plugs of improper heat range.</p> <p>Improperly adjusted or defective breaker points.</p> <p>FUEL SYSTEM</p> <p>Restricted air cleaner.</p> <p>Same items as for engine cold.</p>	<p>ENGINE</p> <p>Perform an engine compression test to determine which mechanical component is at fault.</p> <p>One or more camshaft lobes worn beyond wear limit.</p> <p>Improper valve timing.</p> <p>EXHAUST SYSTEM</p> <p>Restriction in system.</p> <p>TRANSMISSION</p> <p>Improper band adjustment (automatic transmissions).</p> <p>BRAKES</p> <p>Improper adjustment.</p> <p>TIRES</p> <p>Improper pressure.</p>
<p>EXCESSIVE FUEL CONSUMPTION</p>	<p>Determine the actual fuel consumption with test equipment installed in the car.</p> <p>If the test indicates that the fuel consumption is not excessive, demonstrate to the owner how improper driving habits will affect fuel consumption.</p> <p>If the test indicates that the fuel consumption is excessive, make a preliminary check of the following items before proceeding to the fuel and ignition systems.</p> <p>PRELIMINARY CHECKS</p> <p>CHASSIS ITEMS</p> <p>Check:</p> <p>Tires for proper pressure.</p> <p>Front wheel alignment.</p> <p>Brake adjustment.</p> <p>EXHAUST SYSTEM</p> <p>Check the exhaust gas control valve operation (352 engine).</p> <p>ODOMETER</p> <p>Check calibration.</p> <p>IGNITION SYSTEM</p> <p>Check ignition timing.</p> <p>FINAL CHECKS</p> <p>FUEL SYSTEM</p> <p>Check:</p> <p>Fuel pump pressure.</p> <p>Engine idle speed.</p>	<p>Idle fuel mixture needle(s) for proper adjustment.</p> <p>Automatic choke for proper operation.</p> <p>Fast idle speed screw for proper adjustment.</p> <p>Accelerating pump stroke adjustment.</p> <p>Anti-stall dashpot for proper adjustment.</p> <p>Air cleaner for restrictions.</p> <p>Float setting or fuel level.</p> <p>Jets for wear and/or damage.</p> <p>Power valve or Vacuometer operation.</p> <p>Air bleeds for obstructions.</p> <p>Accelerating pump discharge nozzles for siphoning.</p> <p>IGNITION SYSTEM</p> <p>Check:</p> <p>Ignition timing.</p> <p>Spark plug condition and adjustment.</p> <p>Distributor spark advance operation.</p> <p>ENGINE</p> <p>Perform an engine compression test to determine which mechanical component of the engine is at fault.</p> <p>COOLING SYSTEM</p> <p>Check thermostat operation and heat range.</p> <p>TRANSMISSION</p> <p>Check band adjustment (automatic transmissions).</p>



BUY IT NOW!

Click Here To Order



ENGINE TROUBLE DIAGNOSIS GUIDE (Cont.)

<p>ENGINE OVERHEATS</p>	<p>TEMPERATURE SENDING UNIT AND GAUGE Unit or gauge defective, not indicating correct temperature.</p> <p>EXHAUST SYSTEM Exhaust gas control valve inoperative or sticking (352 engine). Restriction in system.</p> <p>ENGINE Cylinder head bolts not properly tightened. Low oil level or incorrect viscosity oil used.</p>	<p>COOLING SYSTEM Insufficient coolant. Cooling system leaks. Drive belt tension incorrect. Radiator fins obstructed. Thermostat(s) defective Cooling system passages blocked. Water pump inoperative.</p> <p>IGNITION SYSTEM Incorrect ignition timing.</p> <p>BRAKES Dragging brakes.</p>
<p>ENGINE FAILS TO REACH NORMAL OPERATING TEMPERATURE</p>	<p>TEMPERATURE SENDING UNIT AND GAUGE Unit or gauge defective, not indicating correct temperature.</p>	<p>COOLING SYSTEM Thermostat inoperative, incorrect heat range, or thermostat not installed.</p>
<p>LOSS OF COOLANT</p>	<p>COOLING SYSTEM Leaking radiator. Loose or damaged hose connections. Water pump leaking. Radiator cap defective. Overheating.</p> <p>ENGINE Cylinder head gasket defective.</p>	<p>Intake manifold to cylinder head gasket defective. Improper tightening of cylinder head or intake manifold bolts. Cylinder block core plugs leaking. Temperature sending unit leaking. Cracked cylinder head or block, or warped cylinder head or block gasket surface.</p>
<p>NOISY HYDRAULIC VALVE LIFTER</p>	<p>A noisy valve lifter can be located by operating the engine at idle speed and placing a finger on the face of the valve spring retainer. If the lifter is not functioning properly, a shock will be felt when the valve seats.</p> <p>Another method of identifying a noisy lifter is by the use of a piece of hose. With the engine operating at idle speed, place one end of the hose near the end of the valve stem and the other end to the ear and listen for a metallic noise. Repeat this procedure on each intake and exhaust valve until the noisy lifter(s) has been located.</p> <p>The most common causes of hydraulic valve lifter troubles are dirt, gum, varnish, carbon deposits, and air bubbles.</p> <p>Dirt in the lifter assembly can prevent the disc valve from seating, or it may become lodged between the plunger and body surfaces. In either case, the lifter becomes inoperative due to failure to "pump-up," or because the internal parts are no</p>	<p>longer free to function properly. When dirt is found to be responsible for lifter malfunction, remove the lifter assembly and thoroughly clean it. Recommended engine oil and filter change intervals should be followed to minimize lifter problems caused by dirt.</p> <p>Deposits of gum and varnish cause similar conditions to exist which may result in lifter malfunction. If these conditions are found to be present, the lifter should be disassembled and cleaned in solvent to remove all traces of deposits.</p> <p>Air bubbles in the lubricating oil, caused by an excessively high or low oil level, may likewise cause lifter malfunction. A damaged oil pick up tube may allow air to be drawn into the lubricating system. To check for the presence of air, remove a valve rocker arm shaft cover and note the condition of the oil as it flows from the valve rocker arm shaft assembly. Perform corrective action as required to remove air from the lubricating oil.</p>

100% SATISFACTION GUARANTEED

BUY IT NOW!

Click Here To Order

PayPal American Express Discover MasterCard VISA

2 TUNE-UP

A tune-up is a systematic procedure for testing various engine components, and, if necessary, bringing them within recommended specifications to restore engine efficiency and performance.

The Tune-Up Schedule (Table 1) is applicable for either a minor or major tune-up. A minor tune-up is recommended each 6000 miles and a major tune-up is recommended each 12,000 miles.

The reference after each operation refers to that part of the manual which describes, in detail, the procedure to be followed. Perform the operations in the sequence listed.

TABLE 1—Tune-Up Schedule

Operation	Perform on		Recommended Procedure
	Minor	Major	
SPARK PLUGS Clean, adjust, and test.	X	X	Part 2-1
ENGINE COMPRESSION Take compression reading of each cylinder.		X	Part 1-1
INTAKE MANIFOLD Check and tighten bolts.	X*	X	Part 1-2, 1-3
DRIVE BELTS Check and adjust the tension of all drive belts.	X	X	Part 2-3
BATTERY Clean battery cables and terminals.		X	Part 9-1
Tighten cable clamps.		X	
Grease battery terminals.		X	
Check battery state of charge.	X	X	
ELECTRICAL			Part 9-1
Check generator output.		X	
Check starter motor current draw.		X	
Check coil output.		X	Part 2-1
Perform a primary circuit resistance test.		X	
Perform a secondary circuit continuity test.		X	Part 2-1
DISTRIBUTOR Check the condition of the breaker points.	X		
Replace the breaker points and the condenser.		X	
and adjust breaker			Part 2-1

Operation	Perform on		Recommended Procedure
	Minor	Major	
DISTRIBUTOR (Cont.) Check and adjust point dwell.		X	Part 2-1
Check and adjust centrifugal advance.		X	
Check and adjust vacuum advance.		X	
Clean distributor cap and rotor.	X	X	
FUEL SYSTEM Clean fuel pump filter bowl.	X	X	Part 2-2
Replace fuel pump filter bowl strainer.		X	
Check fuel pump pressure and capacity.		X	
Clean carburetor fuel bowls and adjust float setting.		X	
ADJUSTMENTS Check and adjust ignition timing.	X	X	Part 2-1
Check and adjust engine idle speed.	X	X	Part 2-2
Adjust idle fuel mixture.	X	X	
EXHAUST Free the exhaust gas control valve (352 engine).	X	X	Part 1-4
COOLING SYSTEM Inspect the radiator, hoses, and engine for leaks.		X	Part 2-3
Add rust inhibitor to radiator.		X	

*On 352 engine only.

100% SATISFACTION GUARANTEED
BUY IT NOW!
 Click Here To Order

PayPal American Express Discover MasterCard VISA

3 TESTS AND ADJUSTMENTS (ENGINE INSTALLED)

CAMSHAFT LOBE LIFT

1. Remove the valve rocker arm shaft assembly and install a solid tappet-type push rod in the push rod bore of the camshaft lobe to be checked.

2. Make sure the push rod is in the lifter push rod cup, then install a dial indicator in such a manner as to have the actuating point of the indicator in the push rod socket and in the same plane as the push rod movement (Fig. 1).

3. Rotate the crankshaft slowly in the direction of rotation until the lifter is on the base circle of the camshaft lobe. At this point, the push rod will be in its lowest position. Zero the dial indicator, then continue to rotate the damper slowly until the push rod is in the fully raised position. Compare the total lift recorded on the indicator with specifications.

4. Continue to rotate the crankshaft until the indicator reads zero. This is a check on the accuracy of the original indicator reading.

VALVE TIMING

The valve timing should be checked when poor engine performance is noted and **all other checks**, such as carburetion, ignition timing, etc. fail to locate the cause of the trouble.

Before the valve timing is checked, check for a bent timing pointer. Bring the No. 1 piston to T.D.C. on the compression stroke and see if the timing pointer is aligned with the T.D.C. mark on the damper.

If the valve timing is not within specifications, check the timing chain, camshaft sprocket, crankshaft sprocket, camshaft, and crankshaft in the order of accessibility.

To check the valve timing with the engine installed, proceed as follows:

1. Install a quadrant on the crankshaft damper.

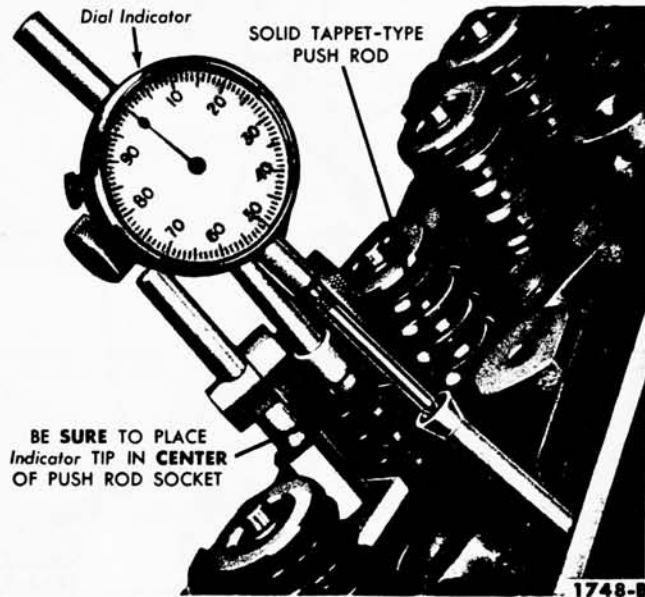

FIG. 1—Camshaft Lobe Lift—Typical

Remove the right valve rocker arm shaft assembly and remove the No. 1 intake valve push rod (the second push rod) and install a solid tappet-type push rod in its place.

2. Make sure the push rod is in the lifter push rod cup, then install a dial indicator in such a manner as to have the actuating point of the indicator in the push rod socket and in the same plane as the push rod movement (Fig. 1).

3. Rotate the crankshaft slowly in the direction of rotation until the lifter is on the base circle of the camshaft lobe. At this point the push rod will be in its lowest position. Zero the dial indicator and continue rotating the crankshaft slowly in the direction of rotation until the dial indicator registers the specified camshaft lobe lift (Table 2).

4. Compare the crankshaft degrees indicated on the quadrant with specifications (Table 2). After the valve opening is checked, continue to rotate the damper to check the valve closing.

VALVE CLEARANCE

A 0.060-inch shorter push rod (color coded white) or a 0.060-inch longer push rod (color coded yellow) is available for service to provide a means of compensating for dimensional changes in the valve mechanism. Valve stem to valve rocker arm clearance should be 0.078-0.218 inch (352 engine) or 0.126-0.226 inch (430 engine) with the hydraulic lifter completely collapsed. Repeated valve reconditioning operations (valve and/or valve seat refacing) will decrease this clear-

TABLE 2—Valve Timing Specifications

Engine	Intake Valve				Exhaust Valve			
	Opens		Closes		Opens		Closes	
	Crankshaft Degrees (ABDC)	Camshaft Lobe Lift (Inch)	Crankshaft Degrees (ABDC)	Camshaft Lobe Lift (Inch)	Crankshaft Degrees (BBDC)	Camshaft Lobe Lift (Inch)	Crankshaft Degrees (ATDC)	Camshaft Lobe Lift (Inch)
002	68°	0.005	68°	0.002	22°	0.005		
?	68°	0.005	63°	0.002	27°	0.005		



BUY IT NOW!

Click Here To Order



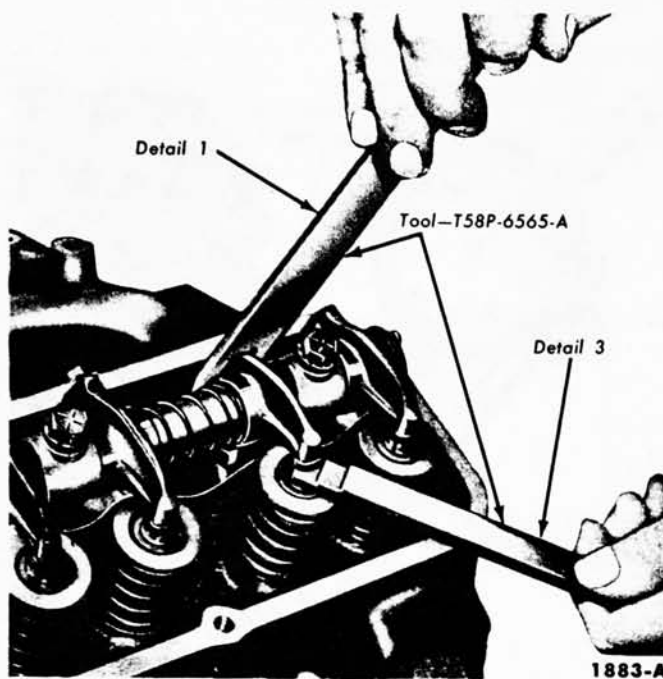

FIG. 2—Valve Clearance—Typical

ance to the point that if not compensated for, the hydraulic valve lifter will cease to function.

The correct operating range of the hydraulic valve lifter plunger must be maintained because:

If the plunger travel is excessive, the lifter pump-up time will be prolonged resulting in excessive valve train noise following engine start-up. If the travel is insufficient to compensate for normal expansion of the valve operating components, the valve would not be permitted to seat properly resulting in a rough engine and/or premature valve failure.

To check the valve clearance:

1. Position the crankshaft as outlined in Steps 2 and 3. Position the hydraulic lifter compressor tool on the rocker arm and slowly apply pressure to bleed down the hydraulic lifter until the plunger is completely bottomed (Fig. 2). Hold the lifter in the fully collapsed position.

On a 352 engine, insert the clearance gauge (Fig. 2) between the valve stem and the rocker arm of the valve to be checked.

enters (430 engine), a standard length push rod may be used.

If the first step of the gauge does not enter (352 engine) or if the feeler gauge does not enter (430 engine) replace the standard push rod with a 0.060-inch shorter push rod.

If the second step of the gauge enters (352 engine) or if a 0.226-inch feeler gauge enters (430 engine), the operating range of the lifter is excessive. This indicates that the incorrect push rod has been installed or severe wear has occurred at the push rod ends, rocker arm, or valve stem. In this case, it will be necessary to determine the area of discrepancy and the incorrect or defective part(s) replaced.

If all the valve train components except the push rod are within limits, install a 0.060-inch longer push rod.

2. Rotate the crankshaft until No. 1 piston is on T.D.C. at the end of the compression stroke. With No. 1 piston on T.D.C., check the following valves:

No. 1 Intake	No. 1 Exhaust
No. 3 Intake	No. 4 Exhaust
No. 7 Intake	No. 5 Exhaust
No. 8 Intake	No. 8 Exhaust

3. Position No. 6 piston on T.D.C. and check the following valves:

No. 2 Intake	No. 2 Exhaust
No. 4 Intake	No. 3 Exhaust
No. 5 Intake	No. 6 Exhaust
No. 6 Intake	No. 7 Exhaust

To replace a push rod, it will be necessary to remove the valve rocker arm shaft assembly.

Upon replacement of a valve push rod and/or valve rocker arm shaft assembly, the engine should not be cranked or rotated until the hydraulic lifters have had an opportunity to leak down to their normal operating position. The leak down rate can be accelerated by using the tool shown in Fig. 2 on the valve rocker arm, apply pressure in a direction to collapse the lifter.

MANIFOLD VACUUM TEST

A manifold vacuum test aids in determining the condition of an engine and also helping to locate the cause of poor engine performance. To test manifold vacuum:

1. Operate the engine for a minimum of 30 minutes at 1200 rpm.
2. Install an accurate, sensitive vacuum gauge on an intake manifold vacuum line.
3. Operate the engine at recommended idle rpm.
4. Check the vacuum reading on the gauge.

TEST CONCLUSIONS

Manifold vacuum is affected by carburetor adjustment, valve timing, the condition of the valves, cylinder compression, and leakage of the manifold, carburetor, or cylinder head gaskets.

Because abnormal gauge readings may indicate that more than one of the above factors is at fault, exercise caution in analyzing an abnormal reading. For example, if the vacuum is low, the correction of one item may increase the vacuum enough to indicate that the trouble has been corrected. It is important, therefore, that each cause of an abnormal reading be investigated and further tests conducted where necessary in order to arrive at the correct diagnosis of the trouble.

Table 3 lists various types of readings and their possible causes.

Allowance should be made for the effect of altitude on the gauge reading. The engine vacuum will decrease with an increase in altitude.

COMPRESSION TEST

1. Be sure the battery is good. Operate the engine for a minimum of 30 minutes at 1200 rpm. Turn the ignition switch off, then remove all the spark plugs.

2. Set the primary throttle plates

in
ste
beir
I
(352

100% SATISFACTION GUARANTEED

BUY IT NOW!

Click Here To Order

PayPal American Express Discover NOVUS MasterCard VISA

and the choke plate in the wide open position.

3. Install a compression gauge in No. 1 cylinder.

4. Crank the engine several times and record the highest reading registered. Note the number of compression strokes required to obtain the highest reading.

5. Repeat the test on each cylinder, cranking the engine the same number of times for each cylinder as was required to obtain the highest reading on No. 1 cylinder.

TEST CONCLUSIONS

A variation of ± 20 pounds from specified pressure is satisfactory. However, the compression of all cylinders should be uniform within 10 pounds.

A reading of more than the allowable tolerance above normal indicates excessive deposits in the cylinder.

A reading of more than the allowable tolerance below normal indicates leakage at the cylinder head gasket, piston rings, or valves.

A low even compression in two adjacent cylinders indicates a cylinder head gasket leak. This should be checked before condemning the rings or valves.

To determine whether the rings or the valves are at fault, squirt the equivalent of a tablespoon of heavy

TABLE 3—Manifold Vacuum Gauge Readings

Gauge Reading	Engine Condition
19-20 inches (352 engine). 17-18 inches (430 engine).	Normal.
Low and steady.	Loss of power in all cylinders caused possibly by late ignition or valve timing, or loss of compression due to leakage around the piston rings.
Very low.	Manifold, carburetor, or cylinder head gasket leak.
Needle fluctuates steadily as speed increases.	A partial or complete loss of power in one or more cylinders caused by a leaking valve, cylinder head or intake manifold gasket leak, a defect in the ignition system, or a weak valve spring.
Gradual drop in reading at engine idle.	Excessive back pressure in the exhaust system.
Intermittent fluctuation.	An occasional loss of power possibly caused by a defect in the ignition system or a sticking valve.
Slow fluctuation or drifting of the needle.	Improper idle mixture adjustment, carburetor or intake manifold gasket leak, or possibly late valve timing.

oil into the combustion chamber, then crank the engine to distribute the oil and repeat the compression test. The oil will temporarily seal leakage past the rings. If approximately the same reading is obtained, the rings are satisfactory, but the valves are leaking. If the compression has increased 10 pounds or more over the original

reading, there is leakage past the rings.

During a compression test, if the pressure fails to climb steadily and remains the same during the first two successive strokes, but climbs higher on the succeeding strokes, or fails to climb during the entire test, it indicates a sticking or stuck valve.

4 CLEANING, INSPECTION, AND RECONDITIONING

INTAKE MANIFOLD

Clean the manifolds in a suitable solvent, then dry them with compressed air.

On the 352 engine, scrape all carbon deposits from the center exhaust passage below the carburetor heat riser. This carbon acts as an insulator restricting the heating action of the hot exhaust gases.

Inspect the manifold for cracks, leaks, or other defects that would make it unfit for further service. Replace all studs that are stripped or otherwise damaged. **Remove all filings and foreign matter that may have entered the manifold as a result of repairs.**

On the 352 engine, check the baffle on the underside of the mani-

leaks, or other defects that would make them unfit for further service.

On the right exhaust manifold of the 352 engine, clean out the auto-

matic choke air heat chamber (Fig. 3). Make sure the air inlet and outlet holes are completely open and the cover does not leak. Blow out the

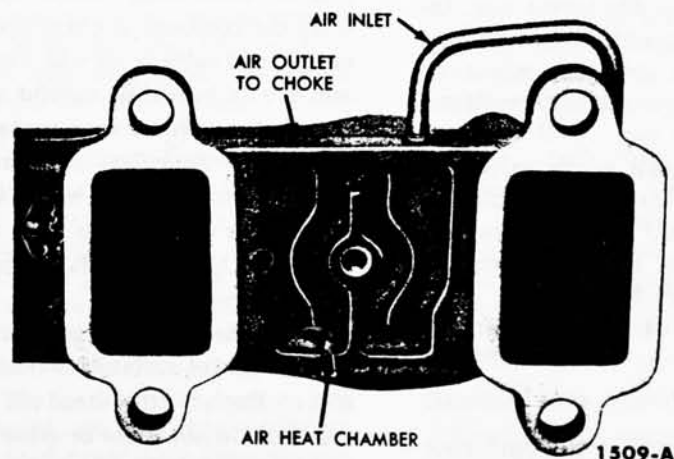

FIG. 3—Automatic Choke Air Heat Chamber—352 Engine



BUY IT NOW!

Click Here To Order



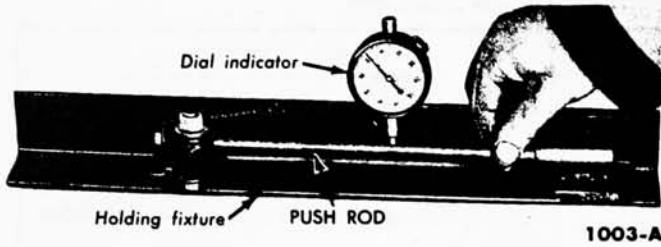

FIG. 4—Push Rod Runout—Typical



FIG. 5—Cylinder Head Flatness—Typical

automatic choke air heat tube with compressed air.

VALVE ROCKER ARM SHAFT ASSEMBLY

Clean all the parts thoroughly. Make sure that all oil passages are open.

Check the clearance between each rocker arm and the shaft by checking the I.D. of the rocker arm bore and the O.D. of the shaft. If the clearance between any rocker arm and the shaft exceeds the wear limit, replace the shaft and/or the rocker arm. Inspect the shaft and the rocker arm bore for nicks, scratches, scores, or scuffs. Dress up minor surface defects with a hone.

Inspect the pad at the valve end of the rocker arms for a grooved radius. If the pad is grooved, replace the rocker arm. **Do not attempt to true this surface by grinding.**

Check for broken locating springs.

checked for straightness while they are installed in the engine by rotating them with the valve closed. They also can be checked with a dial indicator (Fig. 4). If the runout exceeds the maximum limit at any point, discard the rod. **Do not attempt to straighten push rods.**

CYLINDER HEADS

CLEANING AND INSPECTION

With the valves installed to protect the valve seats, remove deposits from the combustion chambers (352 engine) and valve heads with a scraper and a wire brush. **Be careful not to scratch the cylinder head gasket surface.** After the valves are removed, clean the valve guide bores with a valve guide cleaning tool. Use cleaning solvent to remove dirt, grease, and other deposits.

Check the cylinder head for cracks, and the gasket surface for burrs and nicks. Replace the head if it is cracked. **Do not plane or grind more than 0.010 inch from the cylinder head gasket surface.** Remove all burrs and scratches with an oil stone.

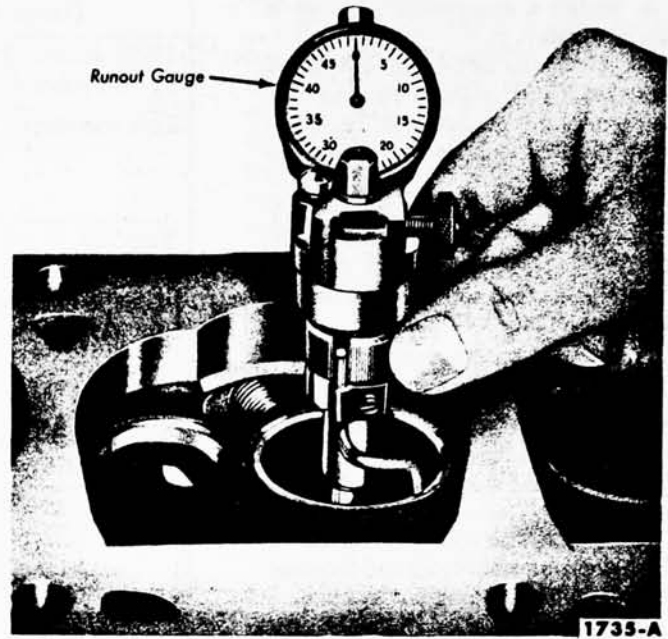

FIG. 6—Valve Seat Runout—Typical

CYLINDER HEAD FLATNESS

Check the flatness of the cylinder head gasket surface (Fig. 5). Specifications for flatness are 0.006 inch maximum overall, or 0.003 inch in any 6 inches.

VALVE SEAT RUNOUT

Check the valve seat runout with an accurate gauge (Fig. 6). Follow the instructions of the gauge manufacturer. The total runout should not exceed the wear limit.

VALVE SEAT WIDTH

Measure the valve seat width (Fig. 7). The intake valve seat width limits are 0.060-0.080 inch and the exhaust valve seat width limits are 0.070-0.090 inch.

REAMING VALVE GUIDES

If it becomes necessary to ream a valve guide (Fig. 8) to install a valve with an oversize stem, a reaming kit is available which contains the following reamer and pilot combinations: a 0.003-inch O.S. reamer with a standard diameter pilot, a 0.015-inch O.S. reamer with a 0.003-inch O.S. pilot, and a 0.030-inch reamer with a 0.015-inch O.S. pilot.

for ce.

100% SATISFACTION GUARANTEED

BUY IT NOW!

Click Here To Order

PayPal American Express Discover Novus MasterCard VISA

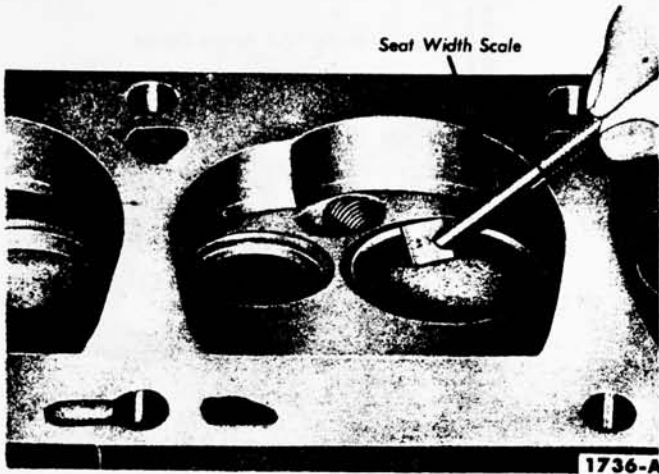

FIG. 7—Valve Seat Width—Typical

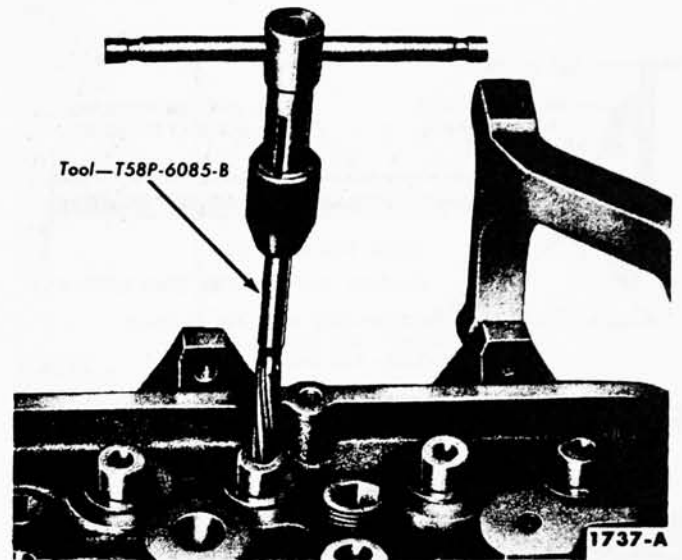

FIG. 8—Reaming Valve Guides—Typical

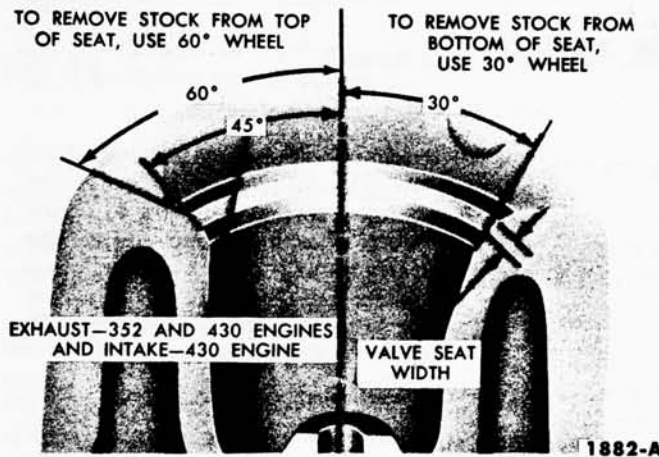

FIG. 9—Valve Seat Refacing—Exhaust 352 and 430 and Intake 430

When going from a standard size valve to an oversize valve, always use the reamers in sequence. Always reface the valve seat after the valve guide has been reamed.

REFACING VALVE SEATS

Refacing of the valve seats should be closely co-ordinated with the refacing of the valve face so the finished seat will match the valve face and be centered. This is important so that the valve and seat will have a good compression tight fit. Be sure that the refacer grinding wheels are properly dressed.

Grind the exhaust valve seats of both engines and the intake valve

the seat has been refaced, measure the seat width (Fig. 7). Narrow the seat, if necessary to bring it within limits.

If the valve seat width exceeds the maximum limits, remove enough stock from the top edge and/or bottom edge of the seat to reduce the width to specifications (Fig. 9 or 10).

On the exhaust valve seats of both engines and the intake valve seats of the 430 engine, use a 30° angle grinding wheel to remove stock from the bottom of the seats (raise the seats) and use a 60° angle wheel to remove stock from the top of the seats (lower the seats).

On the intake valve seats of the 352 engine, use a 15° angle grinding wheel to remove stock from the top of the seats (lower the seats).

The finished valve seat should contact the approximate center of

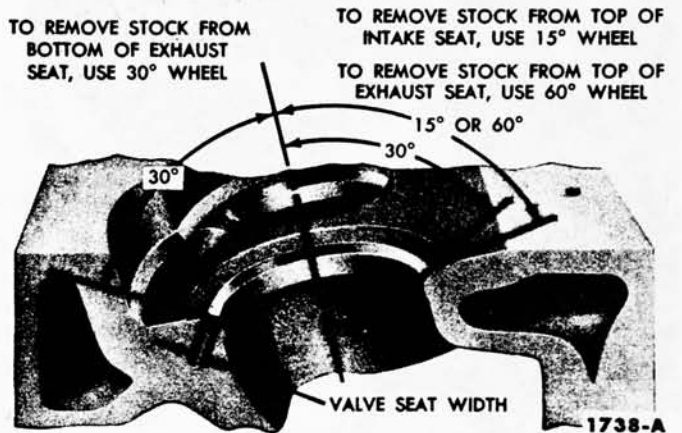

FIG. 10—Intake Valve Seat Refacing—352 Engine

the valve face. To determine where the valve seat contacts the face, coat the seat with Prussian blue, then set the valve in place. Rotate the valve with light pressure. If the blue is transferred to the center of the valve face, the contact is satisfactory. If the blue is transferred to the top edge of the valve face, lower the valve seat. If the blue is transferred to the bottom edge of the valve face, raise the valve seat.

After refacing the valve seat, it is good practice to lightly lap in the valve with a medium grade lapping compound. Remove all the compound from the valve and seat after the lapping operation.

VALVES

CLEANING AND INSPECTION

Remove all deposits from the valve with a fine wire brush or buffing wheel. The critical inspection points and tolerances of the valves are illustrated in Fig. 11.

100% SATISFACTION GUARANTEED

BUY IT NOW!

Click Here To Order

PayPal, American Express, Discover, MasterCard, VISA

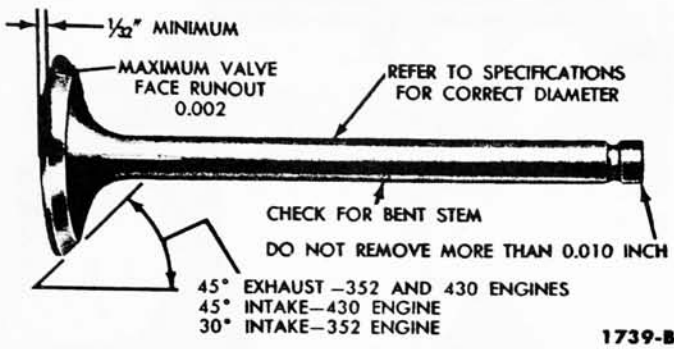

FIG. 11—Critical Valve Tolerances

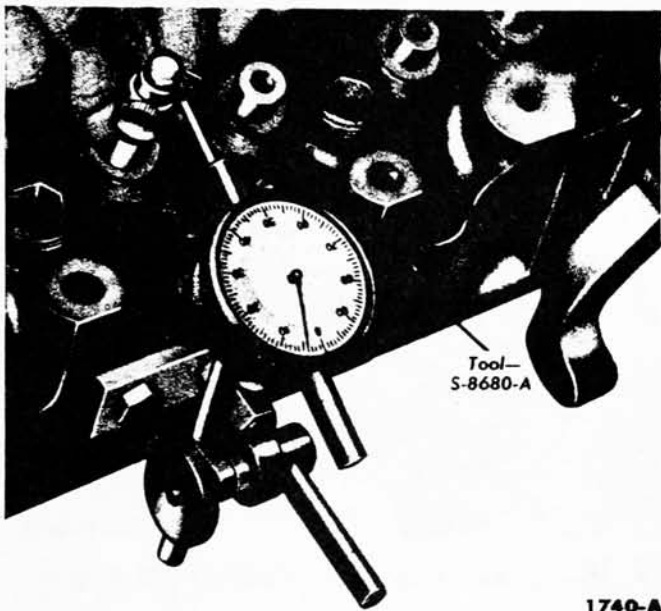

FIG. 13—Typical Valve Stem Clearance

Inspect the valve face and the edge of the valve head for pits, grooves, scores, or other defects. Inspect the stem for a bent condition and the end of the stem for grooves or scores. Check the valve head for signs of burning or erosion, warpage, and cracking. Defects, such as minor pits, grooves, etc. may be removed. Discard valves that are severely damaged.

Inspect the valve springs, valve spring retainers, locks, and sleeves for defects. Discard any defective parts

guide clearance of each valve in its respective valve guide with the tool shown in Fig. 13 or its equivalent.

Install the tool on the valve stem until fully seated and tighten the set screw, then permit the valve to drop away from its seat until the tool contacts the upper surface of the valve guide. Position a dial indicator with a flat tip against the center portion of the spherical section of the tool at approximately 90° to the valve stem. Move the tool back and forth on a plane that parallels normal rocker arm action and take the indicator reading without lifting the tool from the valve guide upper surface. Divide the indicator reading by 2 (division factor of the tool) to obtain the actual stem clearance. If stem clearance exceeds the wear limit, try a new valve.

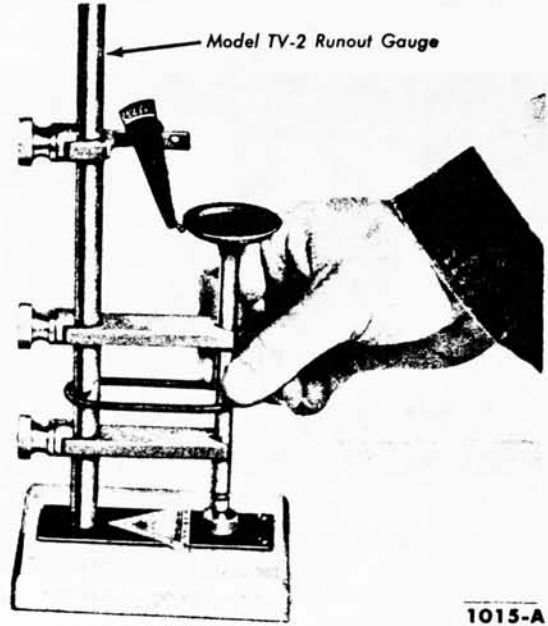

FIG. 12—Valve Face Runout

VALVE SPRING PRESSURE

Check the spring for proper pressure (Fig. 14). Do not remove the damper spring from the 430 engine when checking the pressure. Weak valve springs cause poor engine performance; therefore, if the pressure of any spring approaches the wear limit, replace the spring.

VALVE SPRING SQUARENESS

Check each spring for squareness using a steel square and a surface plate (Fig. 15). Stand the spring and square on end on the surface plate. Slide the spring up to the square. Revolve the spring slowly and observe the space between the top coil of the spring and the square. If the spring is out of square more than 1/16 inch, replace it.

REFACING VALVES

The valve refacing operation should be closely co-ordinated with the valve seat refacing operation so that the finished angle of the valve face will match the valve seat. This is important so that the valve and seat will have a good compression tight fit. Be sure that the refacer grinding wheels are properly dressed.

If the valve face runout is excessive and/or to remove pits and grooves, reface the exhaust valves of both engines and the intake valves of the 430 engine to a true 45° angle. Reface the intake valves of the 352 engine to a true 30° angle. Remove only enough stock to correct

100% SATISFACTION GUARANTEED

BUY IT NOW!

Click Here To Order

Check the valve stem to valve clearance

PayPal American Express Discover Novus MasterCard VISA

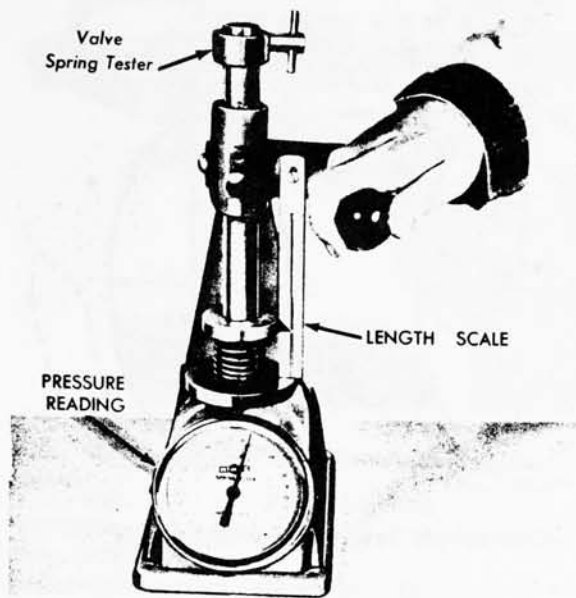

1017-A

FIG. 14—Valve Spring Pressure

the runout or to clean up the pits and grooves. If the edge of the valve head is less than 1/32 inch after grinding, replace the valve as the valve will run too hot in the engine.

Remove all grooves or score marks from the end of the valve stem, then chamfer as necessary. Do not remove more than 0.010 inch from the stem.

After refacing the valves, it is good practice to lightly lap in the valves with a medium grade lapping compound to match the seats. Be sure to remove all the compound from the valve and seat after the lapping operation.

SELECT FITTING VALVES

If the valve stem to valve guide clearance exceeds the wear limit, ream the valve guide for the next oversize valve stem. Valves with oversize stem diameters of 0.003, 0.015, and 0.030 inch are available for service. **Always reface the valve seat after the valve guide has been reamed.**

HYDRAULIC VALVE LIFTERS

The lifter assemblies should be installed in proper sequence so that they

CAMSHAFT AND BEARINGS

Clean the camshaft in solvent and clean solvent and wipe them with a clean, lint free cloth.

Inspect the parts and discard the entire lifter assembly if any part shows signs of pitting, scoring, galling, or evidence of non-rotation. Also, replace the entire assembly if the plunger is not free in the body. The plunger should drop to the bottom of the body by its own weight.

Assemble the lifter assembly and check the assembly for freeness of operation by pressing down on the push rod cup. Also, the lifter assemblies can be tested with a hydraulic valve lifter tester to test the leak down rate. The leak down rate specification is 8-45 seconds. Follow the instructions of the test unit manufacturer.

ROCKER ARM TO VALVE CLEARANCE

If the valve and/or valve seat have been refaced, it will be necessary to check the clearance between the rocker arm pad and the valve stem with the valve train assembly installed in the engine (Page 1-9).

TIMING CHAIN

Clean all parts in solvent and dry them with compressed air. Inspect the chain for broken links and the sprockets for cracks, and worn or damaged teeth. It is recommended

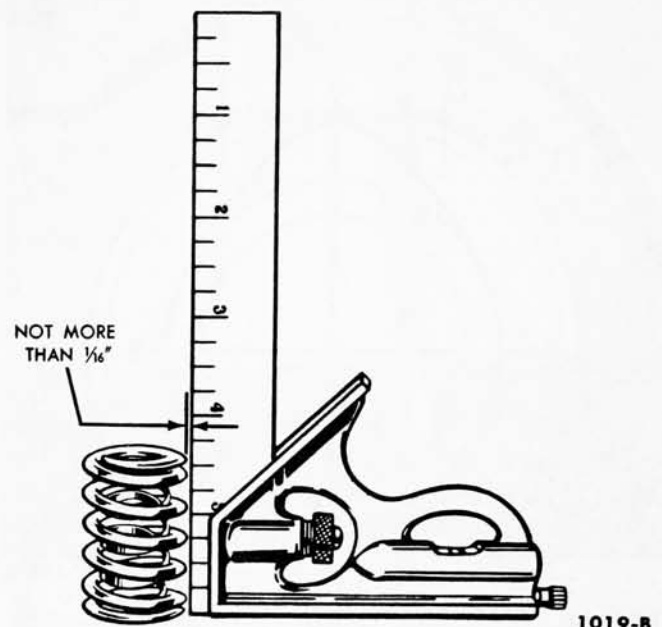

1019-B

FIG. 15—Valve Spring Squareness—Typical

CLEANING AND INSPECTION

Thoroughly clean all the parts in that all the components be replaced if any one item needs replacement. wipe dry. Inspect the camshaft lobes for pitting, scoring, and signs of abnormal wear. Lobe wear characteristics may result in pitting in the general area of the nose portion of the lobe (Fig. 16). This pitting is not detrimental to the operation of the camshaft, therefore, the camshaft should not be replaced until the lobe lift loss has exceeded 0.005 inch.

Check the camshaft journal to bearing clearances by measuring the diameter of the journals and the I.D. of the bearings. If the clearance exceeds the wear limit, the camshaft journals should be refinished for undersized bearings or the camshaft replaced, and/or the bearings should be replaced. Bearings are available prefinished to size for standard and 0.015-inch undersize journal diameters.

Check the distributor drive gear for broken or chipped teeth.

Remove light scuffs, scores, or nicks from the camshaft machined surfaces with a smooth oilstone.

CRANKSHAFT

CLEANING AND INSPECTION

Handle the crankshaft with care to avoid possible fractures or damage to the finished surfaces. Clean

100% SATISFACTION GUARANTEED

BUY IT NOW!

Click Here To Order

PayPal American Express Discover Novus MasterCard VISA

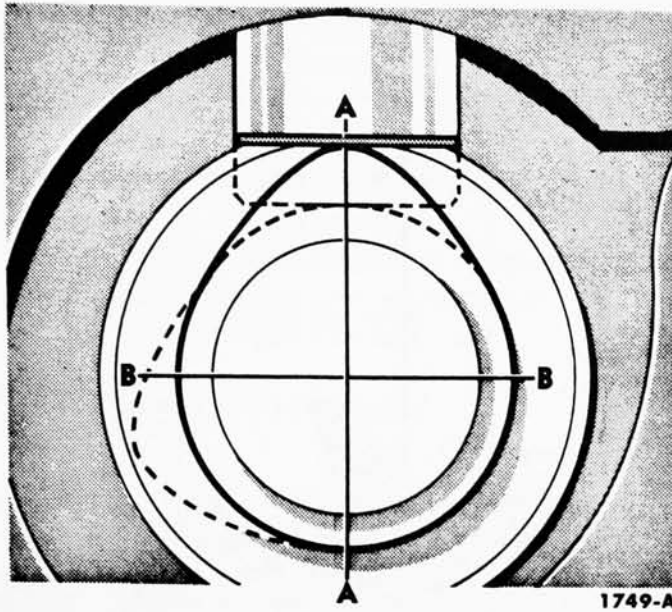

FIG. 16—Camshaft Lobe Lift

the crankshaft with solvent, then blow out all oil passages with compressed air.

Inspect main and connecting rod journals for cracks, scratches, grooves, or scores. Dress minor imperfections with an oilstone. Refinish severely marred journals.

Measure the diameter of each journal in at least four places to determine out-of-round, taper, or undersize condition (Fig. 17).

If the journals exceed the wear limit, they should be refinished to size for the next undersize bearing.

REFINISHING JOURNALS

Refinish the journal to give the proper clearance with the next undersize bearing. If the journal will not "clean up" to give the proper clearance with the maximum undersize bearing available, replace the crankshaft.

Always reproduce the same journal shoulder radius that existed originally. Too small a radius will result in fatigue failure of the crankshaft. Too large a radius will result in bearing failure due to radius ride of the bearing.

After refinishing the journals, chamfer the oil holes, then polish the journals with a No. 320 grit

and checked for conformance to specifications. Various forms of engine wear caused by these parts can be readily identified.

A shiny surface on the pin boss side of the piston usually indicates that a connecting rod is bent or the piston pin hole is not in proper relation to the piston skirt and ring grooves.

Abnormal connecting rod bearing wear can be caused by either a bent connecting rod, an improperly machined crankpin, or a tapered connecting rod bore.

Twisted connecting rods will not create an easily identifiable wear pattern, but badly twisted rods will disturb the action of the entire piston, rings, and connecting rod assembly and may be the cause of excessive oil consumption.

CLEANING AND INSPECTION

Clean the connecting rod in solvent, including the connecting rod bore and the back of the inserts. **Do not use a caustic cleaning solution.** Blow out all passages with compressed air.

Inspect the connecting rods for signs of fractures and the bearing bores for out-of-round and taper. If the bore exceeds the recommended limits and/or if the connecting rod is fractured, it should be replaced.

On a 352 engine, check the piston pin to connecting rod bushing clearance. Replace the connecting rod if the bushing is so worn that it cannot

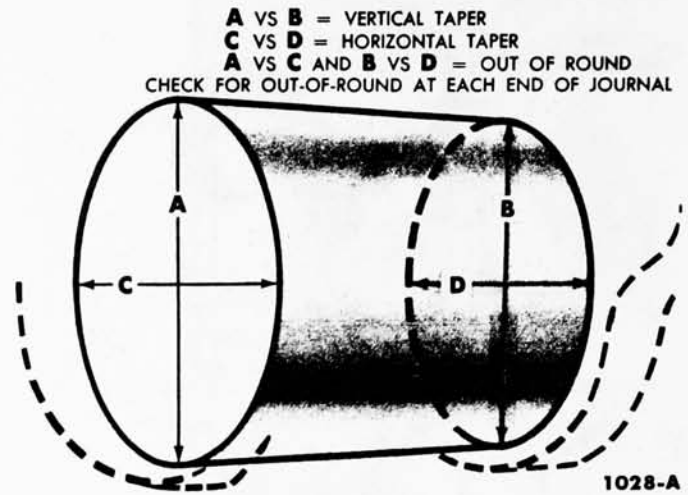

FIG. 17—Crankshaft Journal Measurements

be reamed or honed for an oversize pin.

On a 430 engine, check the I. D. of the connecting rod piston pin bore and the O. D. of the piston pin. Replace the connecting rod if the pin bore is not within specifications. Replace the piston and pin if the pin is not within specifications. To check the interference fit of the pin in the connecting rod, refer to Part 1-3.

Replace defective connecting rod nuts and bolts.

After the connecting rods are assembled to the piston, check them for bend or twist on a suitable alignment fixture. Follow the instructions of the fixture manufacturer. If the bend and/or twist is excessive, the connecting rod should be straightened or replaced.

PISTONS, PINS, AND RINGS

CLEANING AND INSPECTION

Remove deposits from the piston surfaces and from the underside of the piston head. Clean gum or varnish from the piston skirt, piston pins, and rings with solvent. **Do not use a caustic cleaning solution or a wire brush to clean pistons.** Clean the ring grooves with a ring groove cleaner (Fig. 18). Make sure the oil ring slots (or holes) are clean.

Carefully inspect the pistons for fractures at the ring lands, skirts, and pin bosses, and for scuffed, rough, or scored skirts. If the lower inner portion of the ring grooves have high steps, replace the piston.

100% SATISFACTION GUARANTEED

BUY IT NOW!

Click Here To Order

PayPal | American Express | Discover | MasterCard | VISA

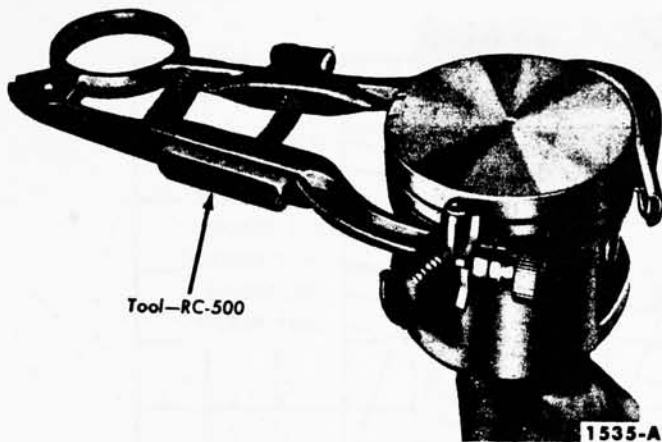

FIG. 18—Cleaning Ring Grooves—Typical

The step will interfere with ring operation and cause excessive ring side clearance.

Spongy, eroded areas near the edge of the top of the piston are usually caused by detonation, or pre-ignition. A shiny surface on the thrust surface of the piston, offset from the centerline between the piston pin holes, can be caused by a bent connecting rod. Replace pistons that show signs of excessive wear, wavy ring lands, fractures, and/or damage from detonation or pre-ignition.

Check the piston to cylinder bore clearance with a tension scale and ribbon and the ring side clearance following the recommended procedures.

Replace piston pins showing signs of fracture or etching and/or wear.

On a 352 engine, check the piston pin fit in the piston and rod bushing.

To check the pin fit in the connecting rod of a 430 engine, refer to Part 1-3.

Replace all rings that are scored, chipped, or cracked. Check the end gap and side clearance. It is good practice to always install new rings when overhauling the engine. **Rings should not be transferred from one piston to another regardless of mileage.**

FITTING PISTONS

Pistons are available for service in standard sizes and 0.003, 0.020, 0.030, 0.040, and 0.060-inch oversize. Standard size pistons are divided into two sizes and are identified by

eration, allow the cylinder bore to cool before the piston fit is checked.

Calculate the size piston to be used by taking a cylinder bore check (Fig. 25), then select the proper size piston to provide the desired clearance.

Make sure the piston and cylinder bore are clean and dry. Attach a tension scale to the end of a feeler gauge ribbon that is free of dents or burrs. The feeler ribbon should be $\frac{1}{2}$ inch wide and of one of the thicknesses listed in Table 4.

Position the ribbon in the cylinder bore so that it extends the entire length of the piston at 90° from the piston pin location. Invert the piston and install it in the bore so that the end of the piston is about $1\frac{1}{2}$ inches below the top of the cylinder block and the piston pin is parallel to the crankshaft axis.

Hold the piston and slowly pull the scale in a straight line with the ribbon, noting the pull required to remove the feeler ribbon (Fig. 19). The piston to cylinder bore clearance should be from 0.0011-0.0029 inch. The wear limit is 0.005 inch.

In Table 4, the diagonal lines represent feeler ribbons of various thicknesses, the horizontal lines represent the pounds pull, and the vertical lines represent the clearances. To determine the clearance, locate the line representing the pounds pull required to remove the feeler ribbon from the cylinder bore. Follow the horizontal

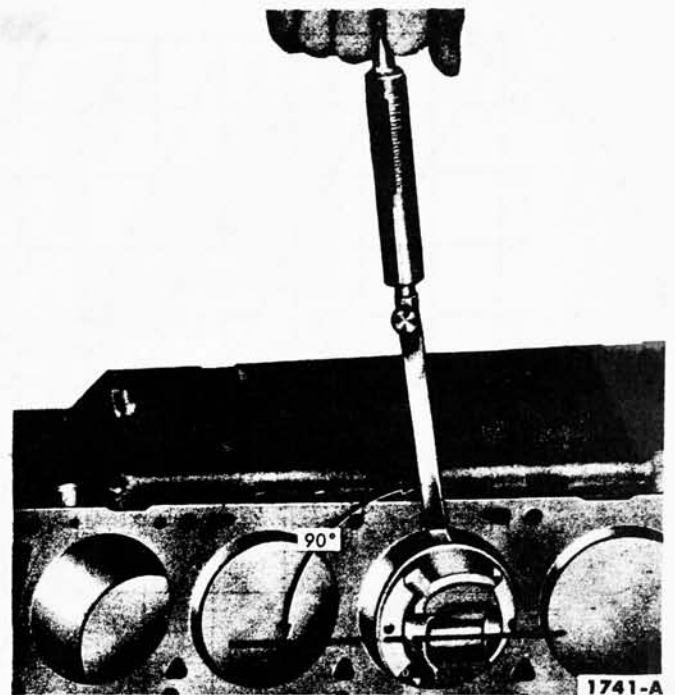

FIG. 19—Checking Piston Fit—Typical

line to the right until it intersects the diagonal line representing the feeler ribbon. Read down the vertical line for the clearance.

Example 1. If a 0.0015-inch feeler ribbon is used and it takes approximately $4\frac{1}{4}$ pounds pull to remove the feeler ribbon, the clearance is approximately 0.0008 inch. This is determined by locating the pounds pull ($4\frac{1}{4}$) in Table 4 and following the line to the right until it intersects with the diagonal line representing the 0.0015-inch feeler ribbon. Read down the vertical line for the clearance (approximately 0.0008 inch).

Example 2. If a 0.003-inch feeler ribbon is used and it takes approximately 9 pounds pull to remove the ribbon, the resultant clearance is approximately 0.0015 inch.

Example 3. If a 0.003-inch feeler ribbon is used and it takes approximately 4 pounds pull to remove the feeler ribbon, the resultant clearance is approximately 0.0026 inch.

If the clearance is greater than the maximum limit, recheck calculations to be sure that the proper size piston has been selected, check for a damaged piston, then try a new piston.

If the clearance is less than the minimum limit, recheck calculations before trying another piston. If none can be fitted, refinish the cylinder for the next size piston.

When a piston has been fitted, mark it for assembly in the cylinder to which it was fitted.

100% SATISFACTION GUARANTEED

BUY IT NOW!

Click Here To Order

PayPal | American Express | Discover | MasterCard | VISA

TABLE 4—Piston Clearance

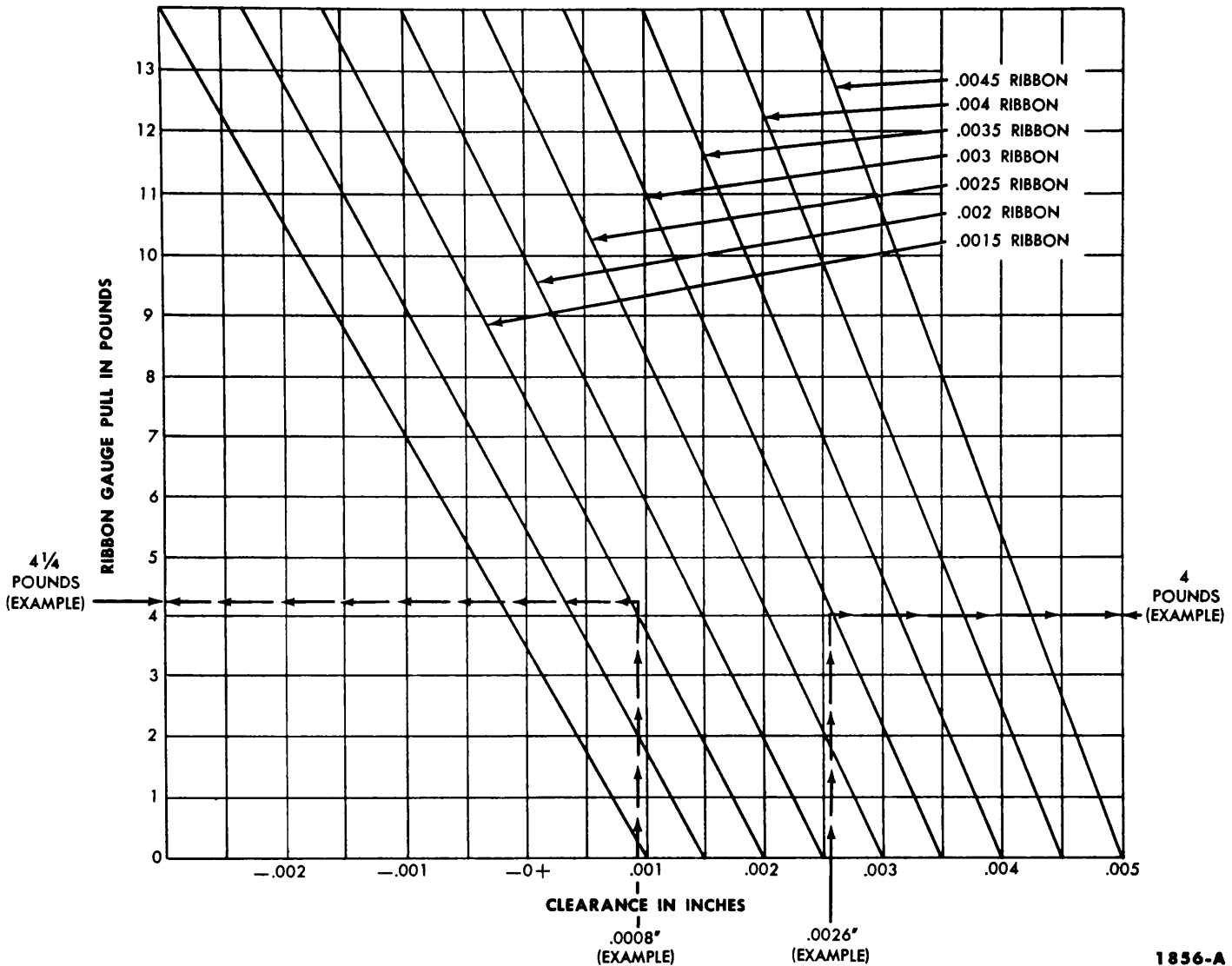

1856-A

If the taper and out-of-round conditions of the cylinder bore are within limits, new piston rings will give satisfactory service provided the piston clearance in the cylinder bore is within limits. If the new rings are to be installed in a used cylinder that has not been refinished, remove the cylinder wall "glaze."

Select the proper ring set for the size piston to be used. The rings must be checked for proper gap in the cylinder bore and for the proper side clearance in the piston grooves. First, check each ring for proper gap as follows:

Position the ring in the cylinder bore and check it is going to be used.

gap between the ends of the ring with a feeler gauge (Fig. 20).

If the gap is less than the recommended lower limit, try another ring set.

FITTING PISTON PINS

The piston pin fit should be a light thumb press fit at normal temperature (70°F). Standard piston pins are coded green.

Pins of 0.001-inch oversize (color coded blue) and 0.002-inch oversize (color coded yellow) are available for the 352 engine.

Oversize piston pins are not available for the 430 engine. Piston and pins are serviced only as an assembly on this engine.

On a 352 engine, if the pin hole in the piston must be reamed, use an expansion-type piloted reamer. Place the reamer in a vise and revolve the piston around the reamer. Set the reamer to the size of the pin bore,

then expand the reamer slightly and trial ream the pin bore. Take a light cut. Use a pilot sleeve of the nearest size to maintain alignment of the bores. Check the hole size, using the new piston pin. If the bore is small, expand the reamer slightly and make another cut. Repeat the procedure until the proper fit is obtained. Check the piston pin for fit in the respective rod bushing. If necessary, ream or hone the bushing to fit the pin.

MAIN AND CONNECTING ROD BEARINGS

CLEANING AND INSPECTION

Clean the bearing inserts and caps thoroughly. Inspect each bearing carefully. Bearings that have a scored, chipped, or worn surface should be replaced. Typical examples of bearing failure and their

100% SATISFACTION GUARANTEED

BUY IT NOW!

Click Here To Order

PayPal, American Express, Discover, MasterCard, VISA



FIG. 20—Piston Ring Gap—Typical

causes are shown in Fig. 21. Check the clearance of bearings that appear to be satisfactory with Plastigage. Fit new bearings following the recommended procedure.

BEARING REPLACEMENT

The main and connecting rod bearing inserts are selective fit and do not require reaming to size upon installation. **Do not file or lap bearing caps or use shims to obtain the proper bearing clearance.**

Selective fit bearings are available for service in standard sizes only. Standard bearings are divided into

two sizes and are identified by a daub of red or blue paint. **Red marked bearings increase the clearance; blue marked bearings decrease the clearance.** Undersized bearings, which are not selective fit, are available for use on journals that have been refinished.

Normally, bearing journals wear evenly and are not out-of-round. However, if a bearing is being fitted to an out-of-round journal, be sure to fit the bearing to the maximum diameter of the journal. If the bearing is fitted to the minimum diameter with minimum clearance, inter-

ference may result, causing an early failure. It is not recommended that bearings be fitted to a crankshaft journal which exceeds the maximum out-of-round specifications. **When replacing standard bearings with new bearings, it is good practice to first try to obtain the proper clearance with two blue bearing halves.**

When checking the width of the Plastigage, check at the widest point in order to get the minimum clearance. Check at the narrowest point in order to get the maximum clearance. The difference between the two readings is the taper.

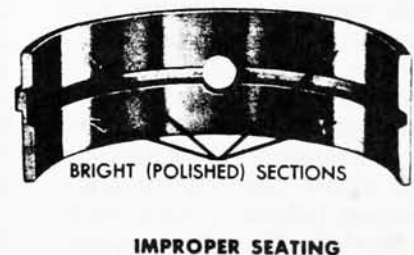

1030-A

100% SATISFACTION GUARANTEED

BUY IT NOW!

Click Here To Order

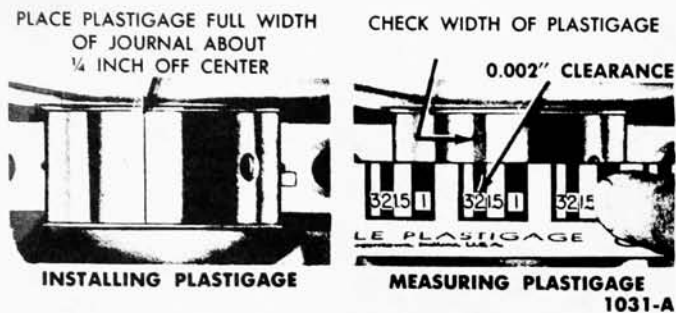

FIG. 22—Installing and Measuring Plastigage—Engine on Work Stand

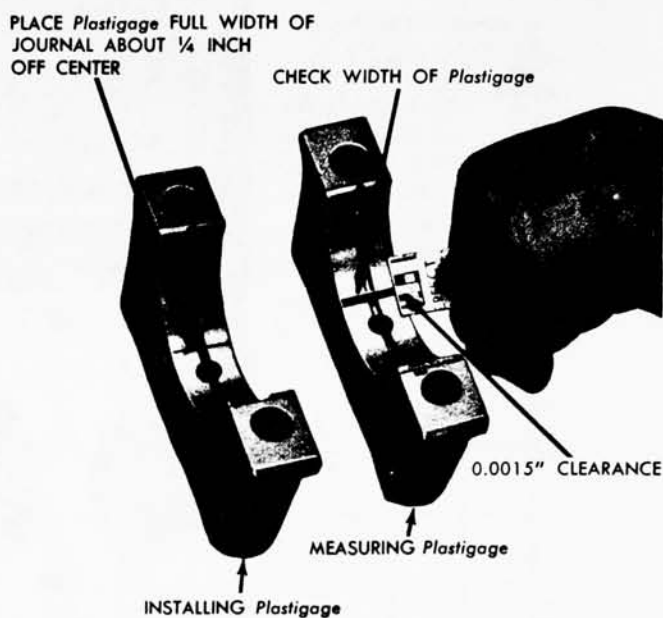

FIG. 23—Installing and Measuring Plastigage—Engine in Chassis

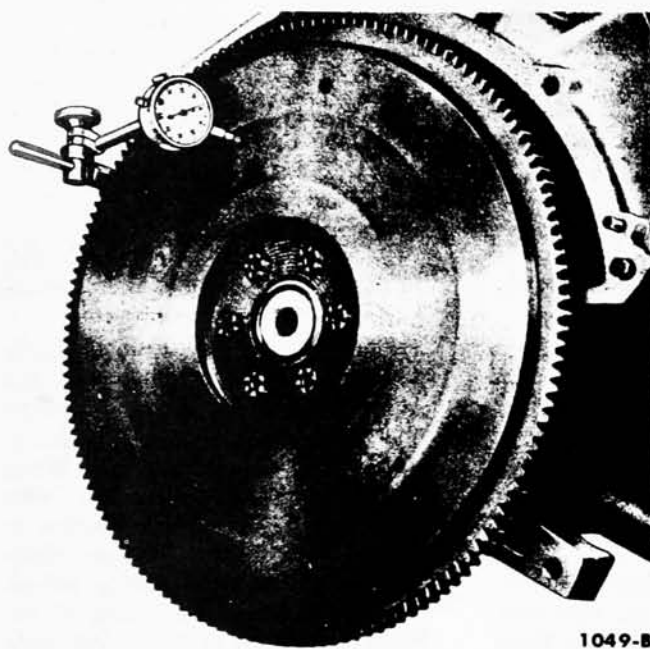

FIG. 24—Typical Flywheel Face Runout

If the clearance is less than the specified limits, try two red bearing halves or a combination of red and blue depending upon the condition. If the standard bearings do not bring the clearance within the desired limits, refinish the crankshaft journal, then install undersize bearings.

Do not get foreign matter under the inserts. In time the foreign matter may distort the bearing and cause bearing failure.

Main Bearings. The following procedure is for the engine installed in the chassis with the crankshaft not re. If the engine is on a work stand, follow steps 1 and follow steps

the bearing surface if the engine is on a work stand.

1. **Replace one bearing at a time, leaving the other bearings securely fastened.** Remove the main bearing cap to which new bearings are to be installed. Insert the upper bearing removal tool (tool 6331) in the oil hole in the crankshaft. Rotate the crankshaft in the direction of engine rotation to force the bearing out of the block.

2. To install the upper main bearing, place the plain end of the bearing over the shaft on the locking tang side of the block. Using tool 6331 in the oil hole in the crankshaft, rotate the crankshaft in the opposite direction of engine rotation until the bearing seats itself. Remove the tool. Replace the cap bearing. Clean the crankshaft journal and bearings.

3. Support the crankshaft so its

weight will not compress the Plastigage and provide an erroneous reading. Position a small jack so it will bear against the counterweight adjoining the bearing which is being checked. Place a piece of Plastigage on the bearing surface the full width of the bearing cap and about 1/4 inch off center (Fig. 23). Install the cap and tighten the bolts to specifications. **Do not turn the crankshaft while the Plastigage is in place.** Remove the cap, then using the Plastigage scale, check the width of the Plastigage.

4. After the bearing has been checked and found to be satisfactory, apply a light coat of engine oil to the journal and bearings, then install the bearing cap. Tighten the cap bolts to specifications.

5. If the rear main bearing is replaced, replace the lower oil seal in the rear main bearing cap and the side seals. The upper oil seal (in the block) cannot be replaced with the crankshaft installed.

Connecting Rod Bearings.

1. Install the new bearings in the connecting rod and cap. Pull the connecting rod assembly down firmly on the crankshaft journal. Place a piece of Plastigage on the lower bearing surface, the full width of the cap and about 1/4 inch off center. Install the cap and tighten

100% SATISFACTION GUARANTEED

BUY IT NOW!

Click Here To Order

PayPal American Express Discover Novus MasterCard VISA

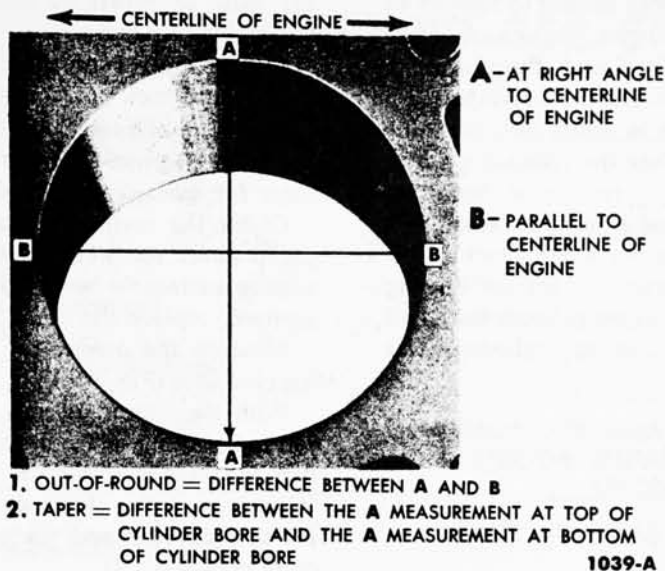

FIG. 25—Cylinder Bore Out-Of-Round and Taper

the connecting rod nuts to specifications. **Do not turn the crankshaft while the Plastigage is in place.**

2. Remove the cap, then using the Plastigage scale check the width of the Plastigage.

After the bearing clearance has been checked and found to be satisfactory, apply a light coat of engine oil to the journal and bearings, then install the connecting rod cap.

3. Repeat the procedure for the remaining connecting rods that require new bearings.

FLYWHEEL—MANUAL-SHIFT TRANSMISSIONS

INSPECTION

Inspect the flywheel for cracks, heat check, or other defects that would make it unfit for further service. Machine the friction surface of the flywheel if it is scored or worn. If it is necessary to remove more than 0.045 inch of stock from the original thickness, replace the flywheel.

Inspect the ring gear for worn, chipped, or cracked teeth. If the teeth are damaged, replace the ring gear.

With the flywheel installed on the crankshaft, check the flywheel face runout.

shaft end play will not be indicated as flywheel runout.

If the runout exceeds the maximum limit, remove the flywheel and check for burrs between the flywheel and the face of the crankshaft mounting flange. If no burrs exist, check the runout of the crankshaft mounting flange. Replace the flywheel or machine the crankshaft flywheel face if the mounting flange runout is excessive.

RING GEAR REPLACEMENT

Heat the defective ring gear with a blow torch on the engine side of the gear, then knock it off the flywheel. **Do not hit the flywheel when removing the ring gear.**

Heat the new ring gear evenly until the gear expands enough to slip onto the flywheel. Make sure the gear is seated properly against the shoulder. **Do not heat any portion of the gear to a temperature higher than 500°F. If this limit is exceeded, the temper will be removed from the ring gear teeth.**

CYLINDER BLOCK

During the disassembly of the cylinder block for engine overhaul, closely inspect the wear pattern on all parts to help diagnose the cause of wear.

CLEANING AND INSPECTION

Thoroughly clean the block in solvent. Remove old gasket material from all machined surfaces. Remove all pipe plugs which seal oil passages, then clean out all the pas-

sages. Blow out all passages, bolt holes, etc. with compressed air. Make sure the threads in the cylinder head bolt holes are clean. Dirt in the threads may cause binding and result in a false torque reading. Use a tap to true-up threads and to remove any deposits.

After the block has been thoroughly cleaned, make a check for cracks. Minute cracks not visible to the naked eye may be detected by coating the suspected area with a mixture of 25% kerosene and 75% light motor oil. Wipe the part dry and immediately apply a coating of zinc oxide dissolved in wood alcohol. If cracks are present, the coating will become discolored at the defective area. Replace the block if it is cracked.

Check all machined gasket surfaces for burrs, nicks, scratches, and scores. Remove minor imperfections with an oil stone. Check the flatness of the cylinder block gasket surface following the procedure and specifications recommended for the cylinder head.

Replace all expansion-type plugs that show evidence of leakage.

Inspect the cylinder walls for scoring, roughness, or other signs of wear. Check the cylinder bore for out-of-round and taper. Measure the bore with an accurate gauge following the instructions of the manufacturer. Measure the diameter of each cylinder bore at the top, middle, and bottom with the gauge placed at right angles and parallel to the centerline of the engine (Fig. 25).

Refinish cylinders that are deeply scored and/or when out-of-round and/or taper exceed the wear limits.

If the cylinder walls have minor surface imperfections, but the out-of-round and taper are within limits, it may be possible to remove the imperfections by honing the cylinder walls and installing new service piston rings providing the piston clearance is within limits. Use the finest grade of honing stone for this operation.

REFINISHING CYLINDER WALLS

Honing is recommended for refinishing cylinder walls only when the walls have minor imperfections, such as light scuffs, scratches, etc. The grade of hone to be used is determined by the amount of metal to be removed. Follow the instructions of the hone manufacturer. If

100% SATISFACTION GUARANTEED

BUY IT NOW!

Click Here To Order

the the the

PayPal American Express Discover Novus MasterCard VISA

coarse stones are used to start the honing operation, leave enough material so that all hone marks can be removed with the finishing hone which is used to obtain the proper piston clearance.

Cylinder walls that are severely marred and/or worn beyond the specified limits should be refinished. Before any cylinder is refinished, all main bearing caps must be in place and tightened to the proper torque so that the crankshaft bearing bores will not become distorted from the refinishing operation.

Refinish only the cylinder or cylinders that require it. **All pistons are the same weight, both standard and oversize; therefore, various sized pistons can be intermixed without upsetting engine balance.**

Refinish the cylinder with the most wear first to determine the maximum oversize. If the cylinder will not clean up when refinished for the maximum oversize piston recommended, replace the block.

Refinish the cylinder to within approximately 0.0015 inch of the required oversize diameter. This will allow enough stock for the final step of honing so the correct surface finish and pattern are obtained. Use clear sharp hones of No. 220-280 grit for this operation.

For the proper use of the refinishing equipment follow the instructions of the manufacturer. Only experienced personnel should be allowed to perform this work.

After the final operation in either of the two refinishing methods described and prior to checking the

piston fit, thoroughly wash the cylinder walls with solvent to remove all abrasive particles, then thoroughly dry the walls. Check the piston fit. Mark the pistons to correspond to the cylinders in which they are to be installed. When the refinishing of all cylinders that require it has been completed and all pistons fitted, thoroughly clean the entire block to remove all particles from the bearing bores, oil passages, cylinder head bolt holes, etc. Coat the cylinder walls with oil.

OIL PAN AND OIL PUMP (AND VACUUM BOOSTER —430 ENGINE)

OIL PAN AND OIL PUMP

OIL PAN

Scrape any dirt or metal particles from the inside of the pan. Scrape all old gasket material from the gasket surface. Wash the pan in a solvent and dry it thoroughly. Be sure all foreign matter is removed from below the baffle plate.

Check the pan for cracks, holes, damaged drain plug threads, a loose baffle, and a nicked or warped gasket surface.

Repair any damage, or replace the pan if repairs can not be made.

OIL PUMP

Cleaning. Wash all parts in a solvent and dry them thoroughly. Use a brush to clean the inside of the

pump housing and the pressure relief valve chamber. Be sure all dirt and chips are removed.

Clean the vacuum pump housing, rotor, and vanes (430 engine).

Inspection. Check the inside of the pump housing and the outer race and rotor for damage or excessive wear.

Check the mating surface of the pump cover for wear. If the cover mating surface is worn, scored, or grooved, replace the cover.

Measure the outer race to housing clearance (Fig. 26).

With the rotor assembly installed in the housing, place a straight edge over the rotor assembly and the housing. Measure the clearance between the straight edge and the rotor and outer race (Fig. 27).

The outer race, shaft and rotor are replaceable only as an assembly.

Check the drive shaft to housing bearing clearance by measuring the O.D. of the shaft and the I.D. of the housing bearing.

Inspect the relief valve spring for a collapsed or worn condition.

Check the relief valve spring tension. If the spring tension is not within specifications and/or the spring is defective, replace the spring.

Check the relief valve piston for scores and free operation in the bore.

On a 430 engine pump, inspect all the vacuum pump parts for damage. Replace the complete vacuum pump if any part is damaged.



1742-A

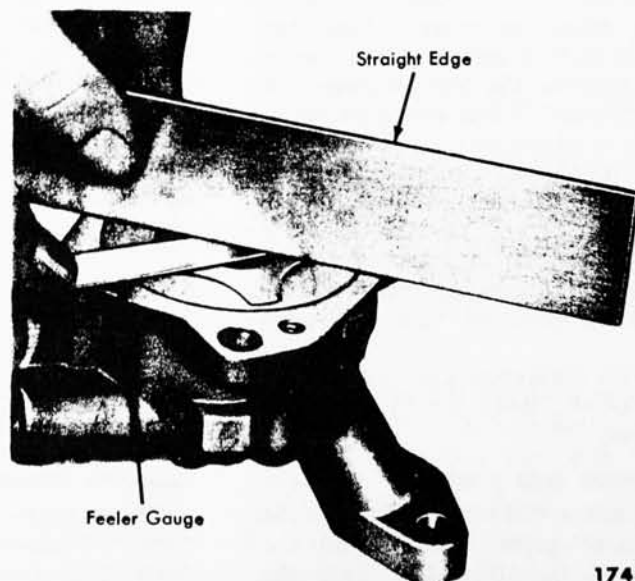

1743-A

FIG. 27—Rotor End Play

PART 1-2

THUNDERBIRD 352 SPECIAL V-8

Section	Page
1 Description.....	1-23
2 Engine Removal and Installation.....	1-28
3 Engine Disassembly (Engine Removed).....	1-30
4 Disassembly and Assembly of Component Parts.....	1-32

Section	Page
Valve Rocker Arm Shaft.....	1-32
Cylinder Heads.....	1-33
Hydraulic Valve Lifters..	1-34
Pistons and Connecting Rods.....	1-35
Oil Pump.....	1-35

Section	Page
5 Engine Assembly (Engine Removed).....	1-36
6 Repair Operations (Engine Installed).....	1-44
Engine Supports.....	1-44
Intake Manifold.....	1-45
Cylinder Heads.....	1-45
Crankshaft Damper.....	1-45
Cylinder Front Cover and Timing Chain.....	1-45
Camshaft.....	1-46
Hydraulic Valve Lifter Replacement.....	1-46
Flywheel.....	1-46
Oil Filter Replacement...	1-47
Oil Pan and Oil Pump...	1-47

1 DESCRIPTION

The Thunderbird 352 Special V-8 engine (Figs. 1 and 2) has a 4.00-inch bore and a 3.50-inch stroke and a total piston displacement of 352 cubic inches. It has a compression ratio of 9.6:1. The patent plate symbol for the engine is "H."

MANIFOLDS

The intake manifold, which also serves as the valve push rod chamber cover, contains a passage through the center section and under the carburetor, through which hot exhaust gases are directed to assist in vaporizing the incoming fuel charge (Fig. 3). The exhaust gases are directed into the intake manifold by a thermostatically controlled exhaust valve (Fig. 4). The valve is located at the outlet of the right exhaust manifold. When the valve is closed or in the "heat on" position, part of the exhaust gases are directed from the right exhaust manifold, through the heat riser passage, to the left exhaust manifold. When the valve opens "heat off," more of the exhaust gases from the right manifold are permitted to flow directly out the exhaust system in the normal manner.

The intake manifold has two sets of fuel passages, each with its own separate inlet connection to the carburetor (Fig. 5). The right side of the carburetor feeds Nos. 1, 4, 6, and 7 cylinders and the left side feeds Nos. 2, 3, 5, and 8 cylinders.

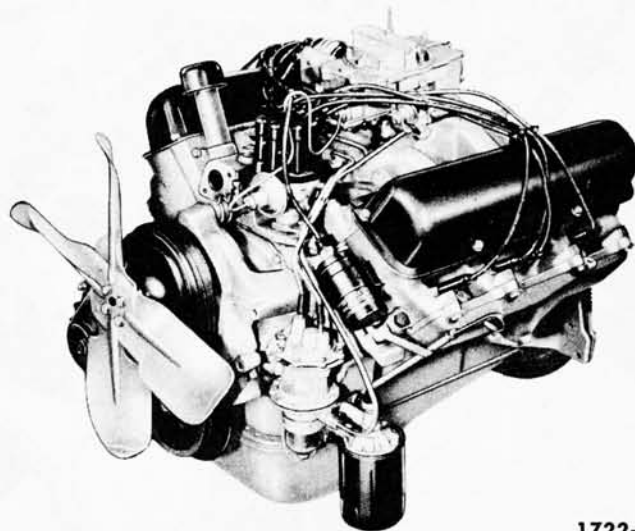

1722-A

FIG. 1—Thunderbird 352 Special V-8 Engine

tain the valves and the valve rocker arm shaft assembly. The combustion chambers are cast in the head. Valve guides are an integral part of the head. The valves are arranged from front to rear on both banks E-I-E-I-I-E-I-E (Fig. 6).

CYLINDER BLOCK

The cylinders are numbered from front to rear on the right bank 1, 2, 3, and 4 and on the left bank 5, 6, 7, and 8. The firing order is 1-5-4-2-6-3-7-8.

The oil pump, mounted inside the

oil pan at the front, is driven by the distributor through an intermediate drive shaft.

The crankshaft is supported by five insert-type main bearings. Crankshaft end thrust is controlled by the flanges of the No. 3 main bearing.

The pistons have two compression rings and one oil control ring. The top compression ring is chrome-plated and the lower compression ring is phosphated-coated. The oil control ring assembly con-

100% SATISFACTION GUARANTEED

BUY IT NOW!

Click Here To Order

PayPal American Express Discover MasterCard VISA

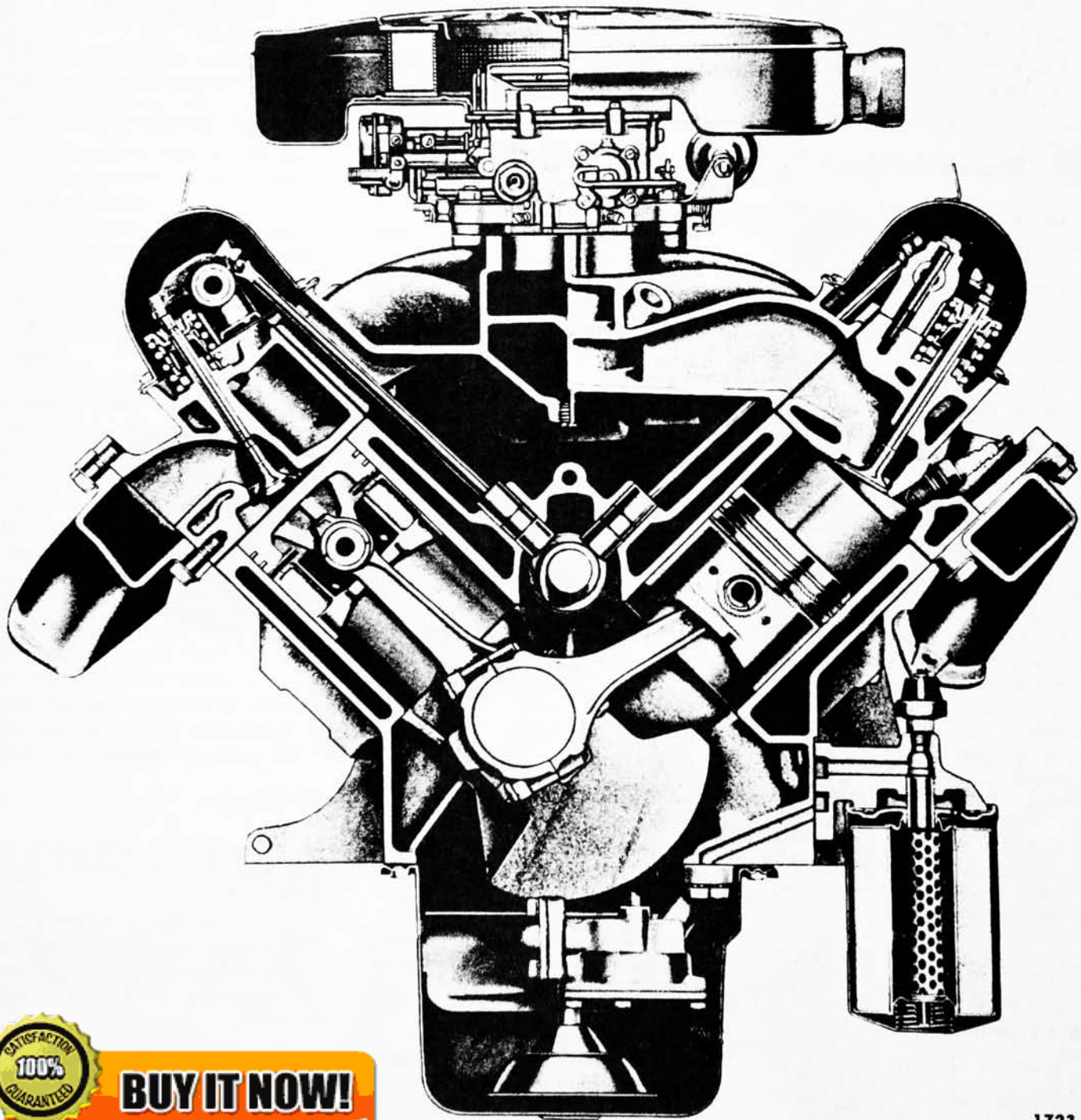

BUY IT NOW!

Click Here To Order

FI 52 Special V-8 Engine

1723-A



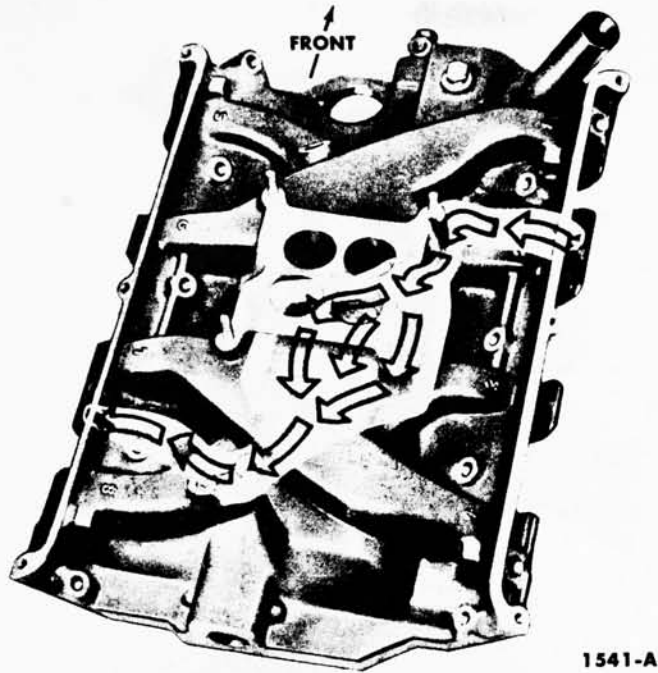

FIG. 3—Intake Manifold Exhaust Gas Passages

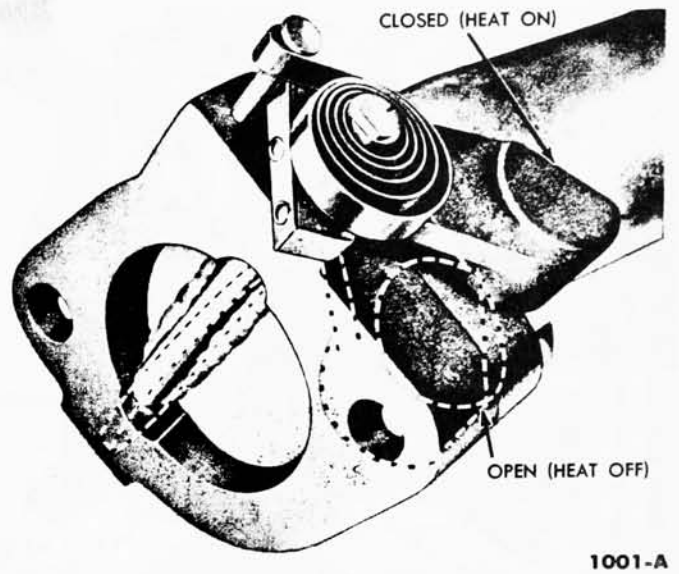

FIG. 4—Exhaust Gas Control Valve

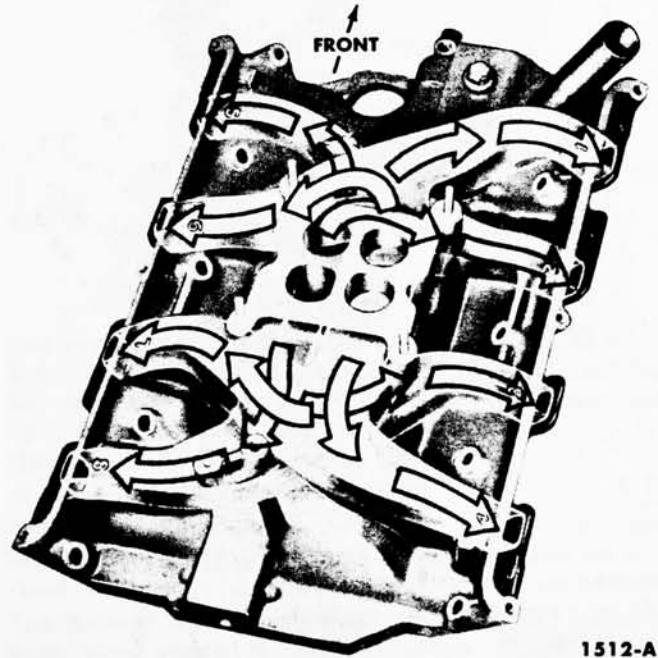

FIG. 5—Intake Manifold Fuel Passages

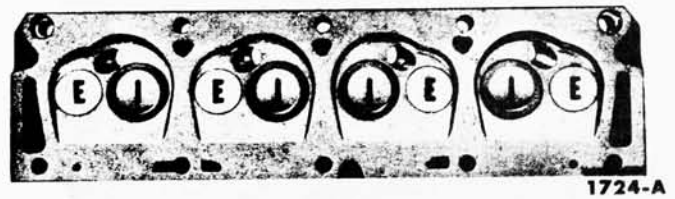

FIG. 6—Valve Port Arrangement

sists of a serrated spring and two chrome-plated steel rails.

VALVE TRAIN

The intake and exhaust valve assembly consists of a valve, valve guide, valve spring, valve retainers, valve lifters, valve push rods, valve rockers, and valve seals. The intake and exhaust valves are driven by a common camshaft. The intake valve is driven by a camshaft lobe that is 180 degrees out of phase with the exhaust valve camshaft lobe. The exhaust valve is driven by a camshaft lobe that is 180 degrees out of phase with the intake valve camshaft lobe. The valve train is lubricated by oil that is forced into the valve lifters and valve rockers by the camshaft.

there is no valve lash adjustment with hydraulic valve lifters, the valve rocker arms do not have adjusting screws.

The camshaft is supported by five insert-type bearings pressed into the block. It is driven by a sprocket and timing chain in mesh with a sprocket on the crankshaft. Camshaft end play is controlled by a

thrust button and spring located between the camshaft sprocket bolt and the cylinder front cover. An eccentric, bolted to the front end of the camshaft, operates the fuel pump.

Hydraulic valve lifters are used which provide zero valve lash and minimize valve train noise. The operation and parts identification of the hydraulic valve lifters are shown in Fig. 7. When the valve is closed, the lifter assembly is on the base circle of the camshaft lobe and the valve push rod is in its lowest position. With the lifter assembly in this position, the plunger spring expands forcing the plunger upward. This action is transmitted to the valve rocker arm via the valve push rod until there is solid contact between the valve and the valve end of the valve rocker arm (zero valve lash). In this position, the oil hole in the lifter and plunger is indexed with the lifter oil gallery and oil is forced under pressure into the plunger. This creates a pressure differential above and below the valve disc. The high pressure above the valve disc

100% SATISFACTION GUARANTEED

BUY IT NOW!

Click Here To Order

PayPal American Express Discover Novus MasterCard VISA

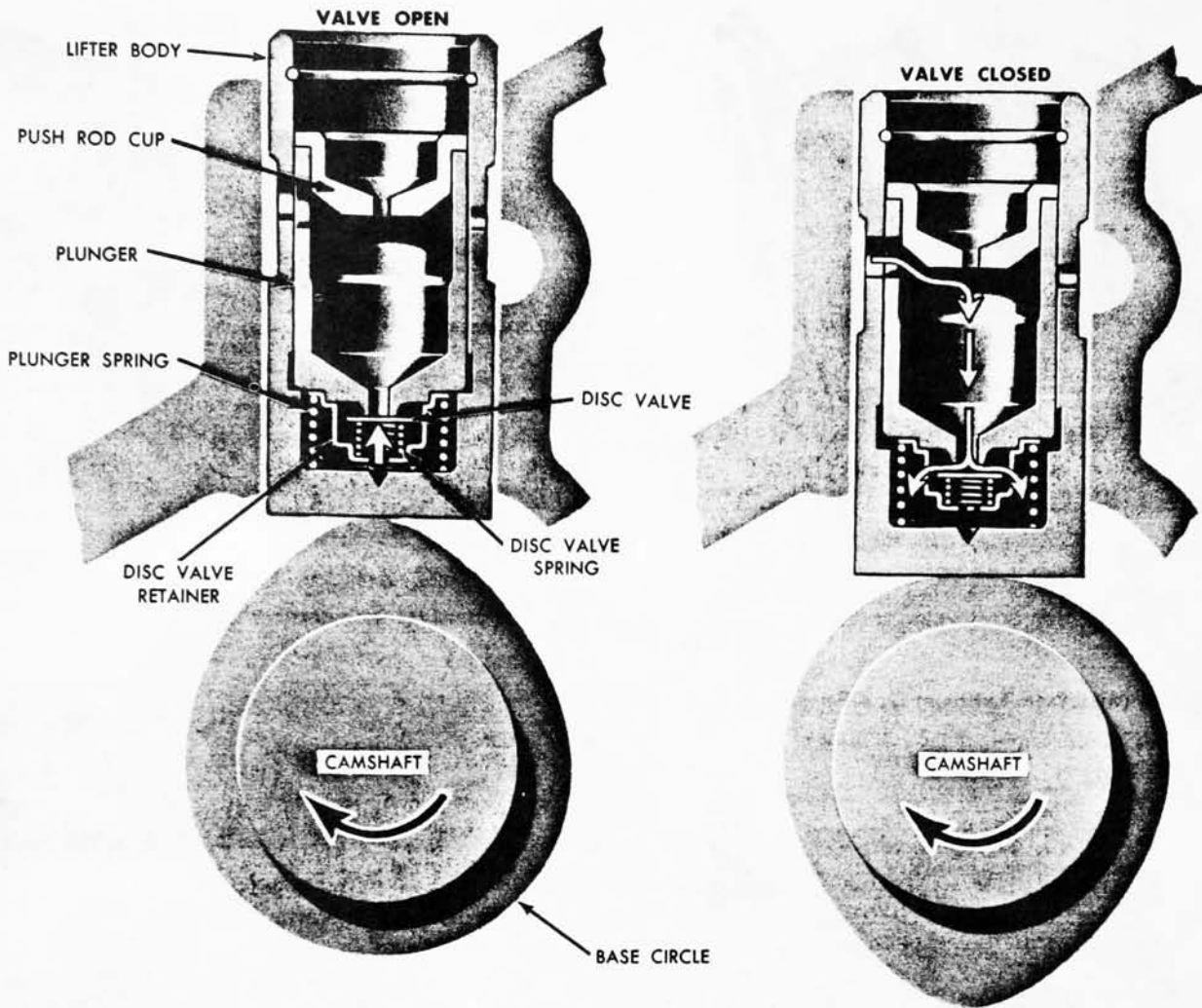

1717-B

FIG. 7—Typical Hydraulic Valve Lifter Operation

forces the valve disc open and the oil fills the area below the plunger equalizing the pressure on each side of the valve disc.

Whenever clearance between the valve and the valve rocker arm tends to be present, the plunger spring expands pushing the plunger until there is solid contact between all parts of the valve train mechanism.

As the camshaft rotates (valve opening) the valve lifter is raised and the sudden increase in oil pressure below the plunger forces the valve disc closed and the lifter becomes a hydraulic ram. During this slight leakage of oil from

the valve disc opens so that the chamber can again be filled. This cycle is repeated for each revolution of the camshaft.

LUBRICATION SYSTEM

Oil from the oil pan sump, located in the front of the oil pan, is forced through the pressure-type lubrication system (Fig. 8) by a rotor-type oil pump. A spring loaded relief valve in the pump limits the maximum pressure of the system. Oil relieved by the valve is directed back to the intake side of the pump.

All the oil discharged by the pump passes through a full flow-type filter before it enters the engine. The filter is mounted in a vertical position at the lower left front of the engine. A relief valve in the filter permits oil to bypass the filter if the element becomes clogged.

From the filter, the oil flows into the main oil gallery which is located in the center of the valve push rod chamber floor. The oil gallery supplies oil to each individual camshaft bearing, through drilled passages in the block. Passages are drilled from each camshaft bearing to each main bearing. Number 1 camshaft bearing feeds No. 1 main bearing, and No. 2 camshaft bearing feeds No. 2 main bearing, etc. The oil then flows through notches or grooves in the main bearings to lubricate the crankshaft journals. A jiggle pin in the main oil gallery front plug allows any air that may be trapped in the oil to escape. The timing chain and sprockets are splash lubricated by oil from the jiggle pin.

The crankshaft is drilled from the main bearings to the connecting rod bearings. The oil flow is as follows:

100% SATISFACTION GUARANTEED

BUY IT NOW!

Click Here To Order

PayPal American Express Discover Novus MasterCard VISA

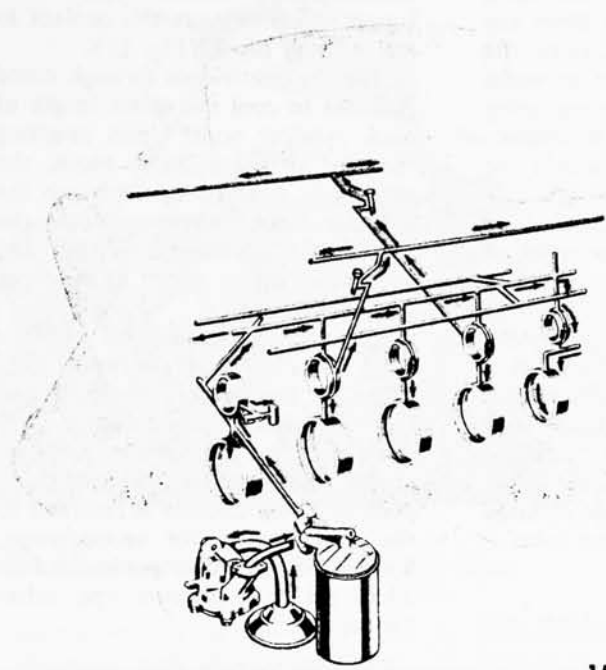

1514-A

FIG. 8—Lubrication System

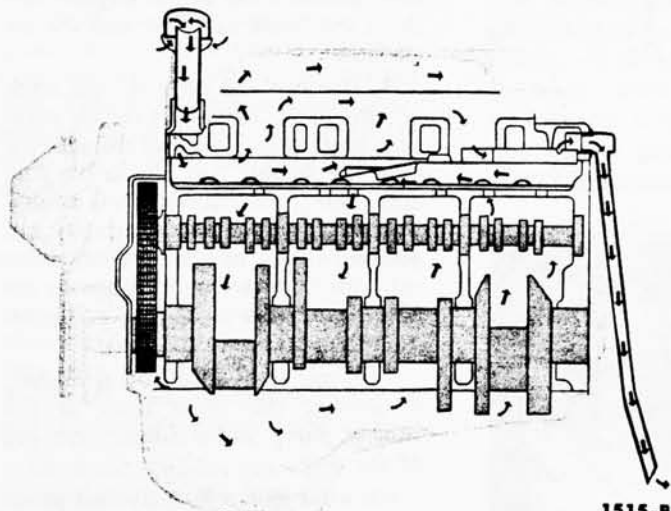

1515-B

FIG. 10—Crankcase Ventilation System

Main Bearing	Serves	Connecting Rod Bearing
No. 1	Serves	No. 1
No. 2	Serves	Nos. 2 and 5
No. 3	Serves	Nos. 3 and 6
No. 4	Serves	Nos. 4 and 7
No. 5	Serves	No. 8

A small groove is located in the connecting rod at the mating face where the cap contacts the connecting rod. This groove allows an oil film to be maintained between the connecting rod and the crankshaft journal. This oil film prevents the connecting rod from scoring the crankshaft journal.

No. 1 connecting rod oils No. 5 cylinder, etc. As the crankshaft turns, the hole in the connecting rod bearing aligns with the hole in the journal causing a direct squirt of oil onto the cylinder wall.

Oil passages are drilled from the main oil gallery to each valve lifter oil gallery. Oil from here feeds the valve lifter assemblies. A reservoir at each valve lifter bore boss traps oil so that oil is available for valve lifter lubrication as soon as the engine starts.

An oil passage is drilled from

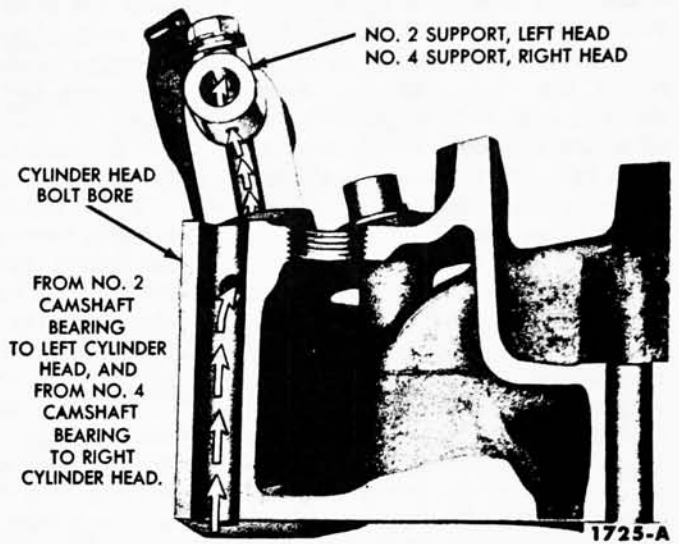

1725-A

FIG. 9—Valve Rocker Arm Shaft Lubrication

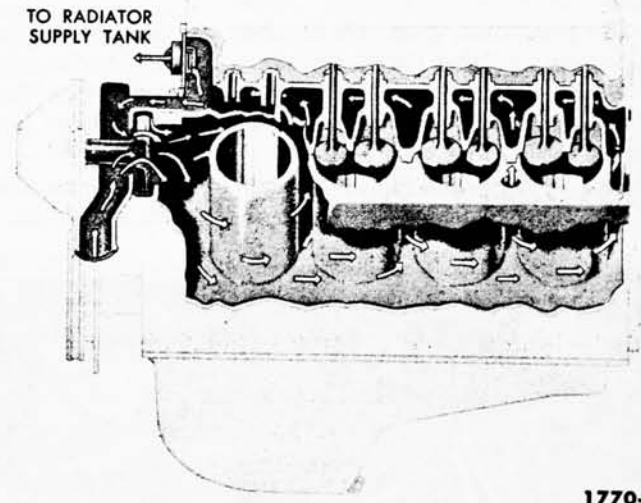

1770-A

FIG. 11—Cooling System

No. 2 camshaft bearing web to the left cylinder head between Nos. 5 and 6 cylinders to lubricate the valve rocker arm shaft assembly (Fig. 9). The oil passage in the cylinder head is drilled from the cylinder head bolt bore to the No. 2 valve rocker arm shaft support.

The oil flows through the valve rocker arm shaft through drilled holes in each valve rocker arm to lubricate the shaft bore and both ends of the valve rocker arm. The excess oil spirals down the rotating push rods and lubricates the push rod seats. The right valve rocker arm shaft assem-



BUY IT NOW!

[Click Here To Order](#)



bly is similarly lubricated from No. 4 camshaft bearing via the No. 4 valve rocker arm shaft support.

A baffle located under the valve rocker arm shaft assembly shields the valve stems from oil splash. Excess oil is returned to the oil pan through drain back holes located at each end of the cylinder head and in the push rod chamber floor.

CRANKCASE VENTILATION

A crankcase ventilation tube is located at the rear of the engine. The forward motion of the car causes a partial vacuum to be formed at the tube outlet. This vacuum action causes air to be drawn through the engine from the oil filler cap located at the front of the intake manifold (Fig. 10). The filler cap contains a filtering element which filters the incoming air.

From the filler cap, the air flows

into the front section of the valve push rod chamber where there are few contaminating vapors. Here, the incoming air has a chance to warm up before contacting contaminating vapors originating in the crankcase. Warm ventilating air minimizes the formation of crankcase sludge.

The ventilating air is directed by a baffle, located on the underside of the intake manifold, upward into the front of both valve rocker arm chambers. The baffle also directs air to the front of the lower crankcase and into the timing chain chamber.

Air from the valve rocker arm chamber and from the crankcase flows into the rear of the valve push rod chamber. All air is then directed out the crankcase ventilation tube.

COOLING SYSTEM

The coolant is drawn from the

bottom of the radiator by the water pump which delivers the coolant to the cylinder block (Fig. 11).

The coolant travels through cored passages to cool the entire length of each cylinder wall. Upon reaching the rear of the cylinder block, the coolant is directed upward into the cylinder heads where it cools the combustion chambers, valves, and valve seats on its return to the front of the engine.

The coolant from each cylinder head flows through the water passages in the intake manifold and past the water thermostat, if it is open, into the top of the radiator. If the thermostat is closed, a small portion of the coolant is returned to the water pump for recirculation. The entire system is pressurized to 13-15 psi by a pressure-type radiator cap.

2 ENGINE REMOVAL AND INSTALLATION

The procedures given are for the engine only without the transmission attached. If the engine and transmission are removed as an assembly, install standard eye bolts with ½-14 threads in the bosses at the top rear of the exhaust manifolds. Then at-

tach the engine lifting bracket and sling to the eye bolts. The engine installation is shown in Fig. 12.

REMOVAL

1. Drain the cooling system and the crankcase. Disconnect the bat-

tery ground cable at the engine. Remove the hood, radiator, and the air cleaner.

2. Remove the oil level dip stick and the coil. Disconnect the oil pressure sending unit wire at the sending unit, the flexible fuel line at the fuel tank line, the flexible windshield wiper line at the vacuum pump and position it out of the way. Remove the wire loom from the clips on the left valve rocker arm cover and position the wires out of the way.

On a car with a windshield washer, disconnect the three lines at the washer pump and position them out of the way.

On a car with a manual-shift transmission, disconnect the accelerator. Remove the accelerator retracting spring.

On a car with an automatic transmission, disconnect the accelerator rod and the transmission rod at the accelerator cross shaft bracket and secure them to the dash panel.

On a car with power steering, disconnect the power steering pump bracket from the water pump, then wire the power steering pump to the hood left hinge in a position that will prevent the oil from draining out.

On a car with power brakes, disconnect the power brake line at the intake manifold and at the flexible line, then release the line from the brackets on the left valve rocker arm



BUY IT NOW!

Click Here To Order



Engine Installation

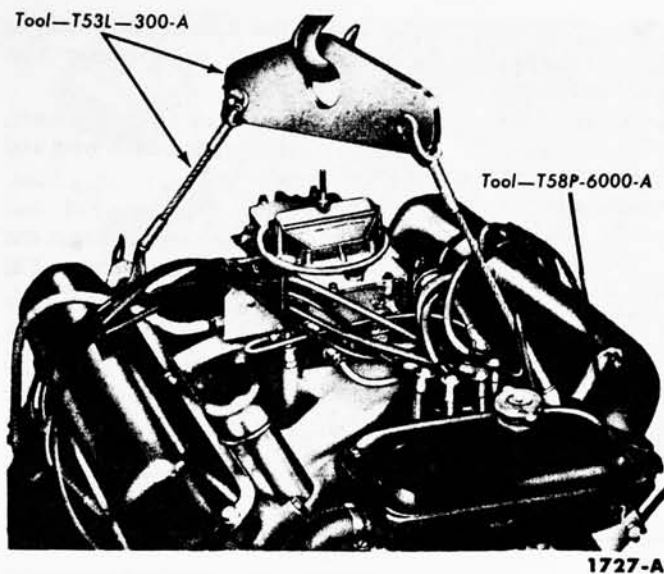

FIG. 13—Engine Lifting Brackets and Sling

cover and remove the line.

On a car with an air conditioner, disconnect the magnetic clutch wire. Isolate the compressor.

3. Disconnect the heater hose at the water pump and at the intake manifold, the generator wires at the generator, and the engine temperature sending unit wire at the sending unit. Remove the engine ground strap and the starter cable retaining bracket from the rear of the right cylinder head.

4. Raise the front of the car. Remove the starter and dust seal (and the automatic transmission fluid filler tube bracket). Remove the crankcase ventilation tube. Disconnect the muffler inlet pipes from the exhaust manifolds, and the engine right and left support insulators at the engine.

On a car with an automatic transmission, remove the converter housing lower access cover and the cover assembly. Remove the flywheel to converter nuts. Secure the converter assembly in the housing. Remove the converter housing to engine lower bolts, and remove the oil cooler lines retaining clamp from the engine block.

On a car with a manual-shift transmission, remove the flywheel housing inspection cover and the clutch pedal retracting spring. Disconnect the clutch release bracket at the equalizer.

Install the engine left lifting bracket on the front of the left cylinder head where the coil mounts. Install the engine right lifting bracket at the rear of the right cylinder head. Attach the engine lifting sling (Fig. 13). Raise the engine slightly and carefully pull it from the transmission. Lift the engine out of the engine compartment and install it on a work stand (Fig. 14).

INSTALLATION

1. Position the exhaust gas control valve, with a new gasket on each side, on the right exhaust manifold studs. Temporarily tie the valve to the manifold. Place a new gasket over the studs of the left exhaust manifold. Loosen the engine right and left support insulators at the chassis. Attach the engine lifting brackets and sling (Fig. 13), then remove the engine from the work stand.

2. Lower the engine carefully into the engine compartment. Make sure the exhaust manifolds are properly aligned with the muffler inlet pipes and the dowels in the block engage the holes in the flywheel housing or converter housing.

On a car with an automatic transmission, start the converter pilot into the crankshaft.

On a car with a manual-shift transmission, start the transmission main drive gear into the clutch disc. It may be necessary to adjust the position of the transmission in relation to the engine if the input shaft will not enter the clutch disc. **If the engine "hangs up" after the shaft enters, turn the**

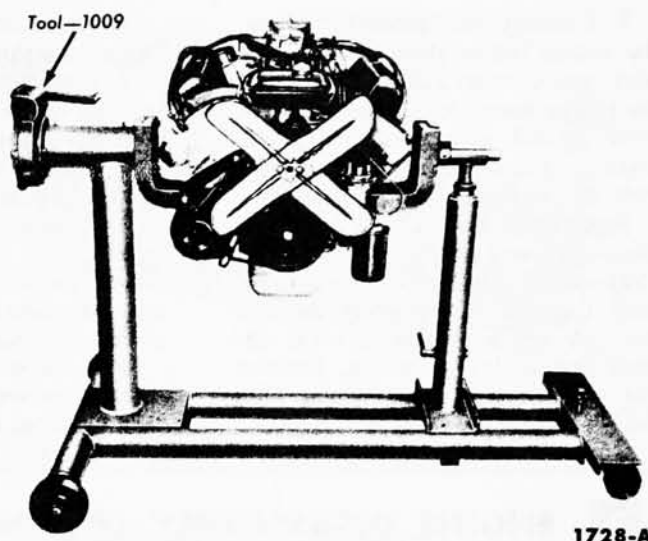

FIG. 14—Engine Work Stand

crankshaft slowly (transmission in gear) until the shaft splines mesh with the clutch disc splines.

3. Install the crankcase ventilation tube and the flywheel housing or converter housing upper bolts, then tighten the bolts to 45-50 foot-pounds torque.

4. Start the engine right and left support insulator to engine bolts. Disconnect the engine lifting sling and remove the lifting brackets.

5. Raise the front of the car. Install the flywheel housing or converter housing lower retaining bolts and tighten them to 45-50 foot-pounds torque.

On a car with an automatic transmission, remove the retainer securing the converter in the housing, then install the flywheel to converter lockwashers and nuts. Tighten the nuts to 25-28 foot-pounds torque. Install the converter lower access plate and the housing cover assembly. Install the oil cooler lines retaining clamp.

On a manual-shift transmission, install the clutch bracket. Connect the clutch release rod and install the clutch retracting spring. Install the flywheel housing lower cover.

6. Tighten all the engine front support insulator bolts and nuts to 45-50 foot-pounds torque. Remove the retainer securing the exhaust gas control valve, then connect both exhaust manifolds to the muffler inlet pipes and tighten the nuts to 23-28 foot-pounds torque. Position the dust seal and install the starter (and the automatic transmission fluid filler tube bracket).

Remove the support from the transmission and lower the car.



BUY IT NOW!

Click Here To Order



7. Connect the generator wires, the engine temperature sending unit wire, and connect the heater hose at the intake manifold. Connect the engine ground strap and install the starter cable retaining clamp to the rear of the right cylinder head.

8. Connect the flexible fuel line, the oil pressure sending unit wire, and the windshield wiper vacuum line. Install the coil and connect the coil primary and high tension wires. Install the oil level dipstick. Position the wire loom in the retaining clips on the left valve rocker arm cover.

On a car with a windshield washer, connect the three washer pump lines.

On a car with an automatic transmission, connect the accelerator rod and the transmission rod.

On a car with manual-shift transmission, install the accelerator retracting spring. Connect the accelerator rod.

On a car with power steering, connect the power steering pump bracket to the water pump.

On a car with power brakes, connect the power brake line to the intake manifold and to the flexible line

and install the line in the retaining clips on the left valve rocker arm cover.

On a car with an air conditioner, connect the magnetic clutch wire and the compressor lines.

9. Install the radiator. Fill and bleed the cooling system. Connect the heater hose at the water pump. Fill the crankcase with the proper grade and quantity of engine oil. Operate the engine at fast idle and check all gaskets and hose connections for leaks. Install the air cleaner.

3 ENGINE DISASSEMBLY (ENGINE REMOVED)

INTAKE MANIFOLD AND DISTRIBUTOR

1. Disconnect the wires at the spark plugs and remove the wires from the ignition harness brackets on the valve rocker arm covers.

2. Remove the distributor cap and spark plug wire assembly.

3. Disconnect the distributor vacuum line at the distributor. Remove the carburetor fuel inlet line, the vacuum pump lines, then remove the fuel pump and discard the gasket. Remove the radiator supply tank.

4. Slide the clamp on the water pump bypass hose toward the water pump. Remove the automatic choke heat tube. Remove the valve rocker arm covers.

5. Crank the engine until the No.

1 piston is at T.D.C. at the end of the compression stroke. Rotate the crankshaft damper an additional 45°. Starting at the No. 4 cylinder, loosen the right valve rocker arm shaft support bolts in sequence, two turns at a time. After the bolts are all loosened, remove the valve rocker arm shaft assembly and the oil baffle plate. Starting at the No. 5 cylinder, follow the same procedure on the left valve rocker arm shaft support bolts. **This procedure must be followed to avoid damage to the valve mechanism.** Remove the valve push rods in sequence.

6. Remove the distributor hold down bolt and clamp and remove the distributor.

7. Remove the 10 intake manifold retaining bolts.

8. Install standard eye bolts with 5/16-18 threads in the left front and right rear rocker arm cover screw holes and attach the engine lifting sling (Fig. 15).

9. Raise the manifold and carefully remove it from the engine. Remove the intake manifold gaskets and seals.

10. Remove the baffle plate from the valve push rod chamber floor by prying up on the baffle with a screwdriver (Fig. 16).

11. Lift the hydraulic valve lifters from the cylinder block and place them in a rack so that they can be installed in their original bore. **The internal parts of each hydraulic valve lifter assembly are matched sets. Do not intermix the parts.** Keep the assemblies intact until they are to be cleaned.

Tool—T53L-300-A

Standard Eye-Bolt
5/16-18 THREAD

1730-A

100% SATISFACTION GUARANTEED

BUY IT NOW!

Click Here To Order

PayPal American Express Discover Novus MasterCard VISA Installation

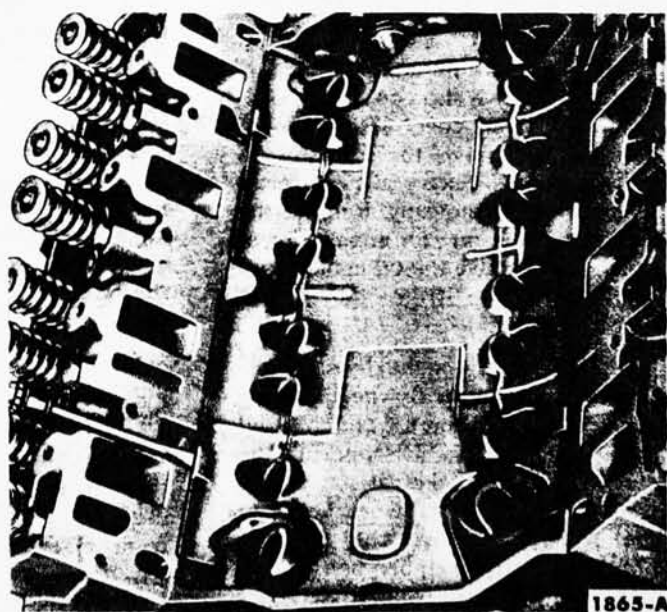

FIG. 16—Baffle Plate Removal

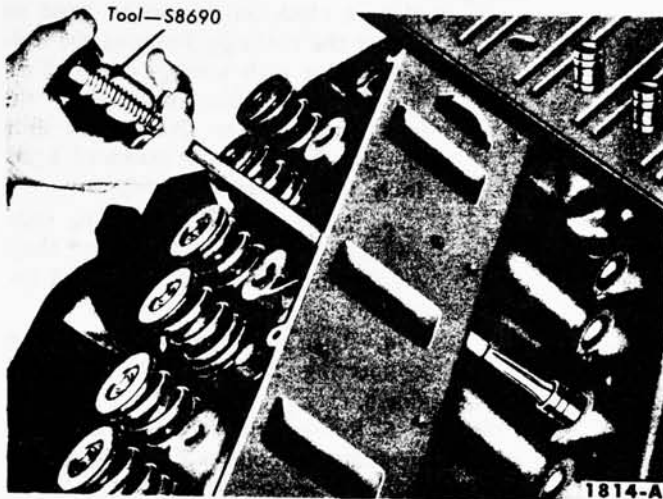

FIG. 17—Hydraulic Valve Lifter Removal

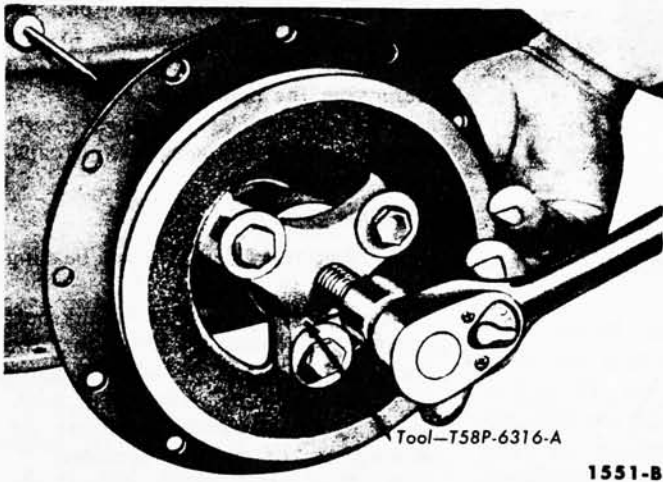

FIG. 19—Crankshaft Damper Removal

12. If the hydraulic valve lifters can not be removed with the fingers, remove them with the tool shown in Fig. 17.

CYLINDER HEADS

1. Remove the exhaust manifold lower retaining bolts and tab washers and remove the exhaust manifolds. Remove the spark plugs.

2. Remove the cylinder head bolts, and then install the cylinder head holding fixtures (Fig. 18).

3. Lift the cylinder head off the block. **Do not pry between the head and the block.** Remove and discard the cylinder head gasket.

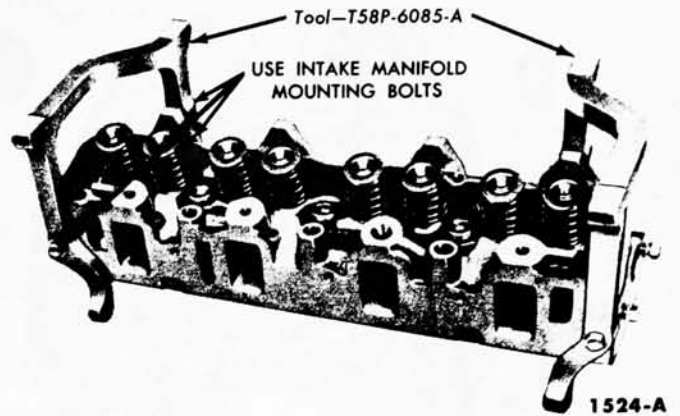

FIG. 18—Cylinder Head Holding Fixtures



FIG. 20—Crankshaft Sleeve Removal

OIL PAN AND OIL PUMP

1. Invert the engine on the work stand.

2. Remove the oil pan retaining screws and remove the oil pan. Discard the gasket.

3. Remove the oil pump attaching bolts and remove the oil pump and inlet tube as an assembly, and remove the oil pump drive shaft. Discard the oil pump gasket.

FLYWHEEL

1. On a flywheel for a manual-shift transmission, mark the pressure plate cover so that it can be replaced in the same position, and remove the clutch pressure plate and cover assembly.

2. Remove the flywheel retaining bolts and remove the flywheel.

CYLINDER FRONT COVER

1. Disconnect the drive belt ad-

justing arm at the generator. Remove the generator support bolt at the water pump and the bracket bolt at the cylinder block. Remove the generator, brackets, and drive belts.

2. Remove the water pump, pulley, and fan as an assembly.

3. On a car with power steering, remove the two cap screws and lockwashers securing the power steering pulley to the crankshaft damper. Then remove the pulley.

4. Remove the large cap screw and washer from the end of the crankshaft. Install the puller on the crankshaft damper (Fig. 19) and remove the damper.

5. If the crankshaft sleeve is not stepped down (the same O.D. on both ends), remove it as shown in Fig. 20. If the crankshaft sleeve is stepped down (different O.D. on each end), remove it with a three-jawed puller (tool 7675-N).

6. Remove the screws fastening the cylinder front cover to the block. Then remove the cylinder

100% SATISFACTION GUARANTEED

FILTER AND ADAPTER

BUY IT NOW!

Click Here To Order

PayPal, American Express, Discover, MasterCard, VISA



FIG. 21—Timing Chain Removal or Installation

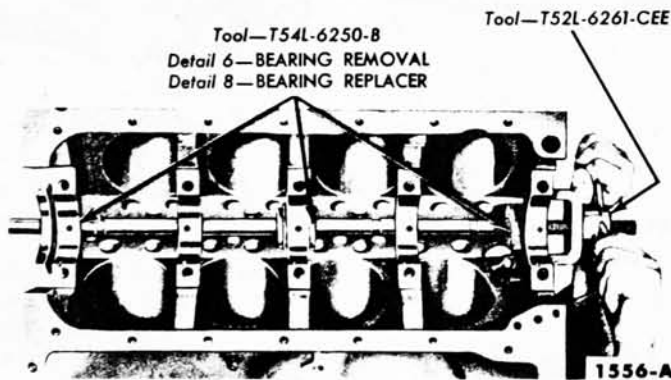

FIG. 22—Camshaft Bearing Removal or Installation

front cover. Discard the cylinder front cover gasket.

TIMING CHAIN AND SPROCKETS

1. Remove the crankshaft front oil slinger.
2. Remove the camshaft thrust button and spring, the sprocket cap screw, the thrust button spring retainer, and the fuel pump eccentric.
3. Slide both sprockets and the

timing chain forward, and remove the sprockets and timing chain as an assembly (Fig. 21).

CONNECTING ROD ASSEMBLIES

1. Turn the engine on the work stand so that the front end is up.
2. Remove any ridge and/or carbon deposits from the upper end of the cylinder bores. Move the piston to the bottom of its travel and

place a cloth on the piston head to collect the cuttings. Remove the cylinder ridge with a ridge cutter. Follow the instructions furnished by the tool manufacturer. **Never cut into the ring travel area in excess of 1/32 inch when removing ridges.**

3. Make sure all connecting rods and caps are marked so that they can be installed in their original locations.

4. Turn the crankshaft until the connecting rod being removed is down.

5. Remove the nuts from the connecting rod bolts, and then pull the cap off the rod.

6. Push the connecting rod and piston assembly out the top of the cylinder with the handle end of a hammer. **Avoid damage to the crankpin or the cylinder wall when removing the piston and rod.**

7. Remove the bearing inserts from the connecting rods and caps.

CRANKSHAFT

1. Remove the main bearing caps.

2. Carefully lift the crankshaft out of the cylinder block so that the thrust bearing surfaces are not damaged. **Handle the crankshaft with care to avoid possible fracture or damage to the finished surfaces.**

3. Remove the rear journal oil seal from the block and rear bearing cap, and remove the cap to block side seals.

4. Remove the main bearing inserts from the block and bearing caps.

CAMSHAFT

Carefully remove the camshaft by pulling it toward the front of the engine. Use caution to avoid damaging the journals and lobes.

CAMSHAFT BEARINGS

Drill a 1/2-inch hole in the camshaft rear bearing bore plug and use tool T-7600-E to remove the plug. Remove the camshaft bearings (Fig. 22).

ASSEMBLY OF COMPONENT PARTS

each end of the valve rocker arm shaft, then remove the flat washers and spring washers.

2. Slide the rocker arms, springs,

and the supports off the shaft. Be sure to identify all the parts.

3. If it is necessary to remove the plugs from each end of the shaft,

100% SATISFACTION GUARANTEED

BUY IT NOW!

Click Here To Order

PayPal, American Express, Discover, MasterCard, VISA

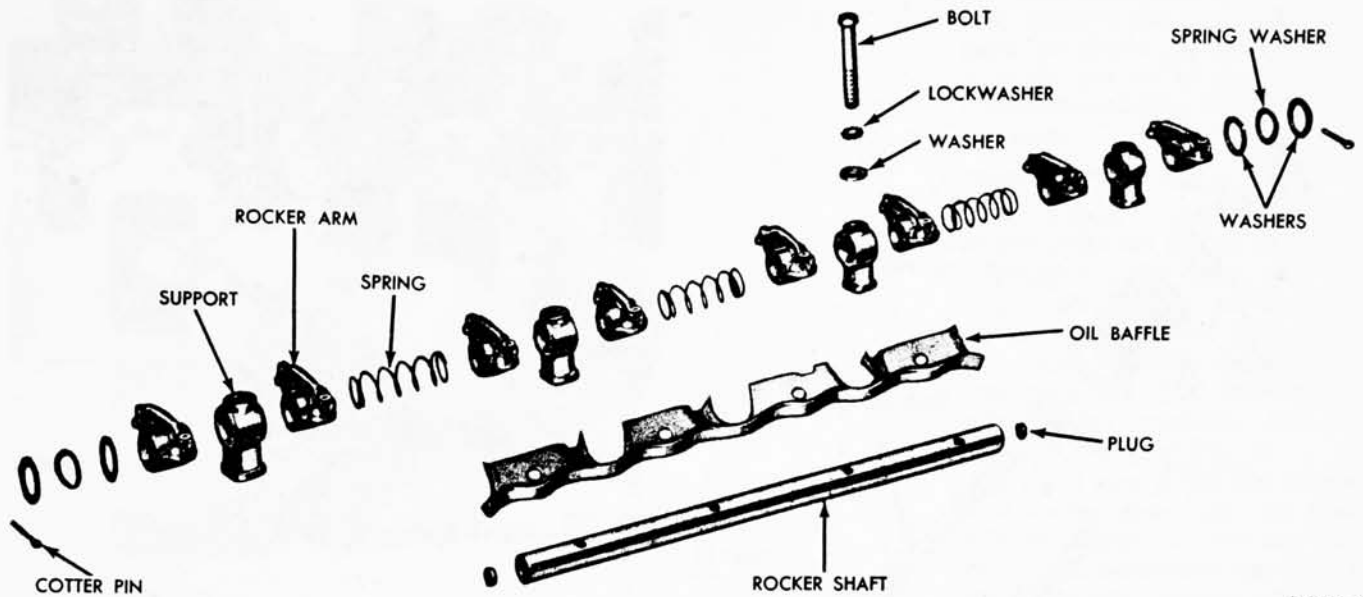

1527-C

FIG. 23—Valve Rocker Arm Shaft Assembly

drill or pierce one plug. Then insert a steel rod through the plug and knock out the plug on the opposite end. Working from the open end, knock out the remaining plug.

ASSEMBLY

1. Oil all the moving parts with engine oil.
2. If the plugs were removed from the ends of the shaft, use a blunt tool or large diameter pin

punch and install a plug, cup side out, in each end of the rocker arm shaft.

3. Install the rocker arms, supports, and springs in the order shown in Fig. 23. **Be sure the oil holes in the shaft are facing downward.** Complete the assembly by installing the remaining two flat washers with the spring washer between them and install the cotter pin.

CYLINDER HEADS

DISASSEMBLY

1. Clean the carbon out of the cylinder head combustion chambers before removing the valves.
2. Compress the valve springs (Fig. 24). Then remove the spring retainer locks, and release the spring.

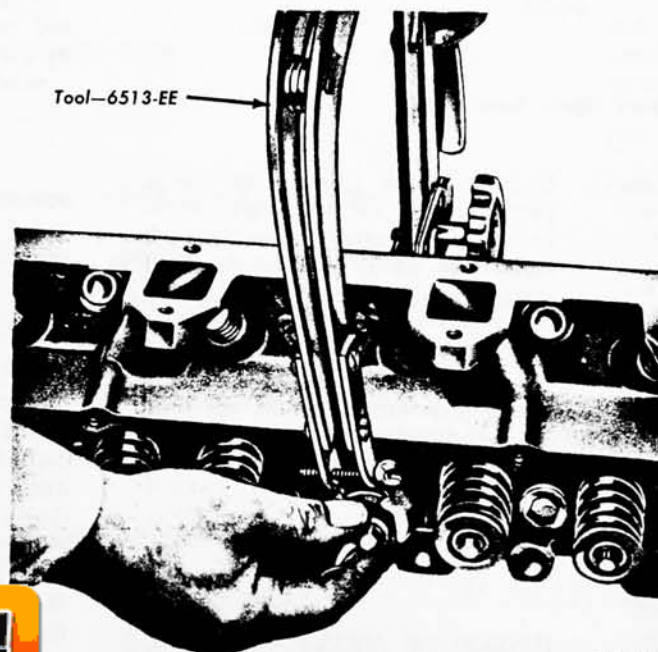

1525-A

24—Valve Spring Retainer Locks—Removal or Installation



BUY IT NOW!

Click Here To Order



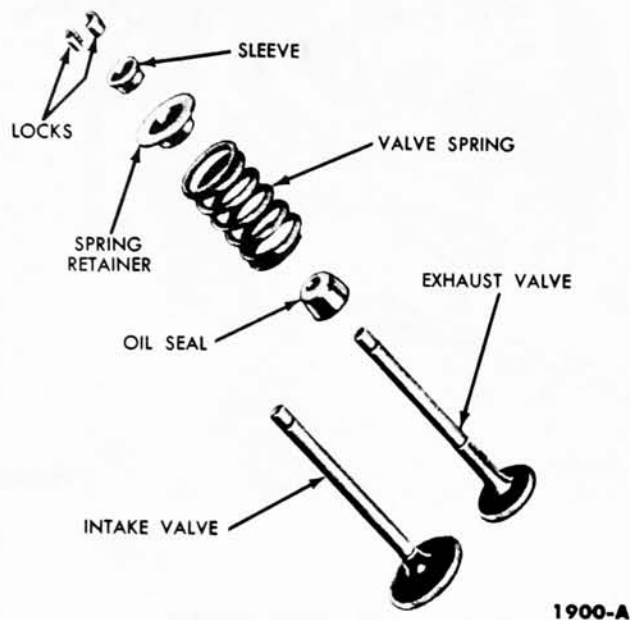

FIG. 25—Valve Assembly

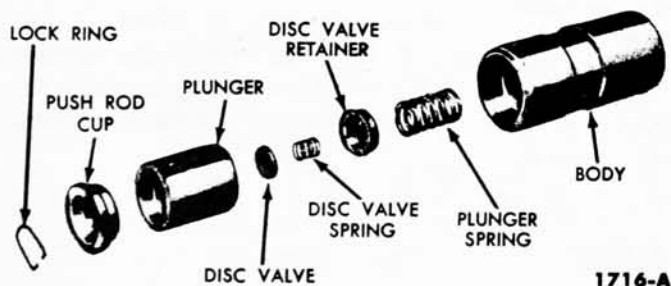

FIG. 27—Typical Hydraulic Valve Lifter Assembly

3. Remove the sleeve, spring retainer, spring, stem seal, and valve. Discard the valve stem seals. Identify all valve parts.

ASSEMBLY

1. Install each valve (Fig. 25) in the guide from which it was removed or to which it was fitted. Install a new stem seal on the valve.

2. Install the valve spring over the valve, and then install the spring retainer and sleeve.

Compress the spring and install the spring retainer locks (Fig. 24).

bled height is greater than $1\frac{27}{32}$ inches, install the necessary 0.030-inch thick spacer(s) between the cylinder head spring pad and the valve spring to bring the assembled height to the recommended height of $1\frac{13}{16}$ - $1\frac{27}{32}$ inches. **Do not install spacers unless necessary. Use of spacers in excess of recommendations will result in overstressing the valve springs which will lead to excessive load loss and spring breakage.**

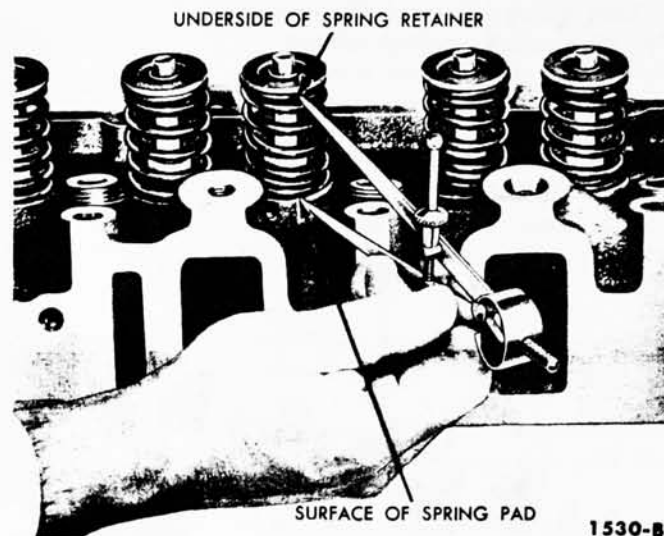

FIG. 26—Valve Spring Assembled Height

improper valve operation may result. Disassemble and assemble each lifter separately. Keep the lifter assemblies in proper sequence so that they can be installed in their original bore.

DISASSEMBLY

1. Grasp the lock ring with needle nose pliers to release it from the groove. It may be necessary to depress the plunger to fully release the lock ring.

2. Remove the push rod cup, plunger, and spring.

3. Invert the plunger assembly and remove the disc valve retainer by carefully prying up on it with a screwdriver. Then remove the disc valve and spring.

ASSEMBLY

A typical hydraulic valve lifter is shown in Fig. 27.

1. Place the plunger upside down on a clean work bench.

2. Place the disc valve in position over the oil hole on the bottom of the plunger. Set the disc valve spring on top of the disc.

3. Position the disc valve retainer over the disc and spring and push the retainer down into place on the plunger.

4. Place the plunger spring, and then the plunger (open end up) into the lifter body.

5. Place the push rod seat in the plunger.

6. Depress the plunger. Then position the closed end of the lock ring



BUY IT NOW!

Click Here To Order

HYDRAULIC VALVE LIFTERS

Each valve lifter is a matched assembly. If the parts of one lifter are inter-mixed with those of another,



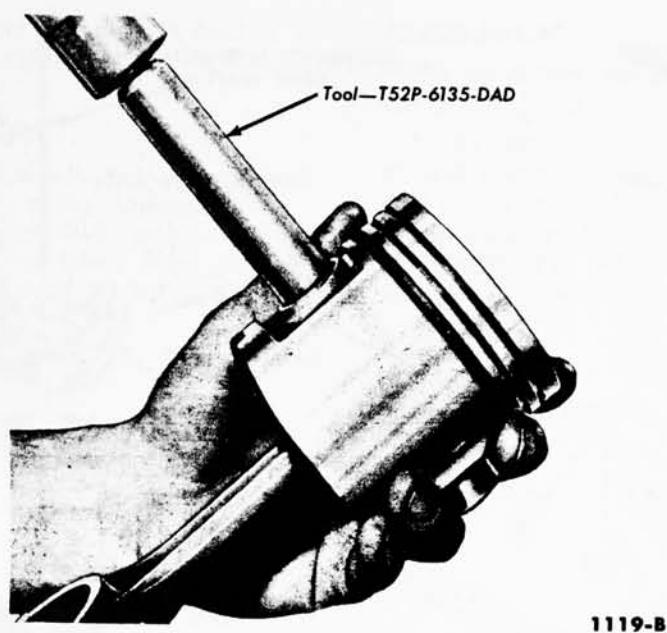

FIG. 28—Piston Pin Removal

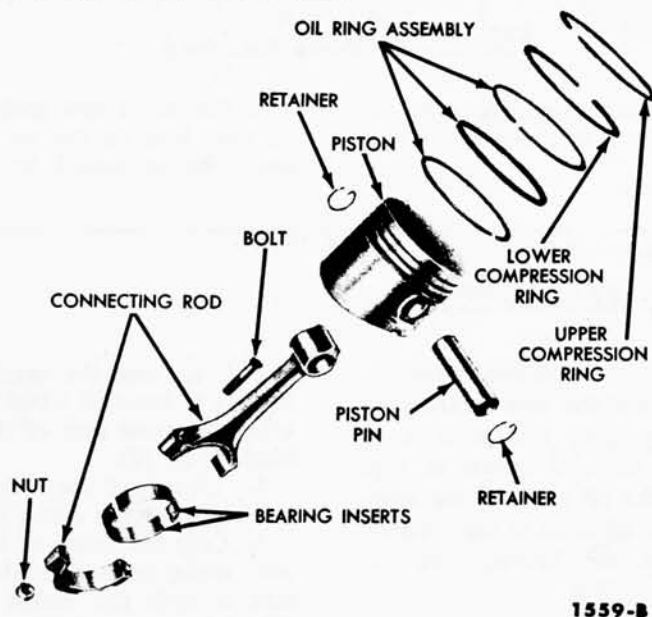

FIG. 29—Piston, Connecting Rod, and Related Parts

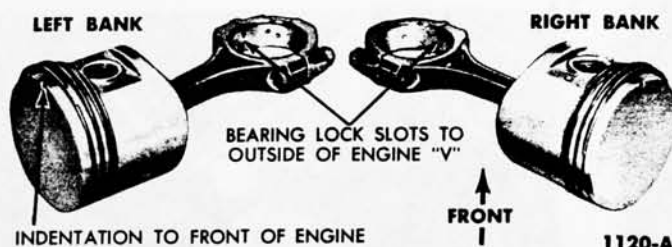

FIG. 30—Connecting Rod and Piston Assembly

and installation in the same cylinder from which they were removed.

2. Remove the piston rings. Remove the piston pin retainers, then drive the pin out of the piston and connecting rod (Fig. 28). Discard the retainers.

ASSEMBLY

The piston, connecting rod and related parts are shown in Fig. 29.

1. Lubricate all parts with light engine oil. Position the connecting rod in the piston and push the pin into place. Assemble the piston and connecting rod with the oil squirt hole in the connecting rod positioned as shown in Fig. 30.

2. Insert new piston pin retainers by spiraling them into the piston with the fingers. Do not use pliers. Follow the instructions contained on the piston ring package and install the piston rings.

3. Check the ring side clearance of the compression rings with a feeler gauge inserted between the ring and its lower land (Fig. 31). The gauge should slide freely around the entire ring circumference without binding. Any wear that occurs will form a step at the inner portion of the lower land. **If the lower lands have high steps, the piston should be replaced.**

4. Be sure the bearing inserts and the bearing bore in the connecting rod and cap are clean. Foreign material under the inserts may distort the bearing and cause a failure. Install the bearing inserts in the connecting rod and cap with the tangs fitting in the slots provided.

OIL PUMP

DISASSEMBLY

1. Remove the oil inlet tube from the oil pump and remove the gasket.

2. Remove the cover retaining screws, then remove the cover. Remove the inner rotor and shaft assembly, then remove the outer race.

3. Insert a self threading sheet metal screw of the proper diameter into the oil pressure relief valve chamber cap and pull the cap out of the chamber. Remove the spring and plunger.

ASSEMBLY

The oil pump assembly is shown in Fig. 32.

1. Oil all parts thoroughly.

2. Install the oil pressure relief valve plunger, spring, and a new cap.

PISTONS AND CONNECTING RODS

DISASSEMBLY

1. Mark the pistons and pins to assure assembly with the same rod



BUY IT NOW!

Click Here To Order



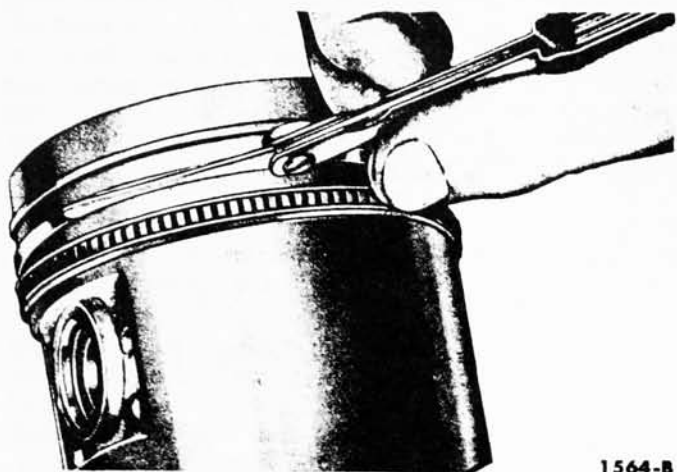

1564-B

FIG. 31—Ring Side Clearance

3. Install the outer race, and the inner rotor and shaft assembly. The inner rotor and shaft, and the outer race are serviced as an assembly. One part should not be replaced without replacing the other. Install

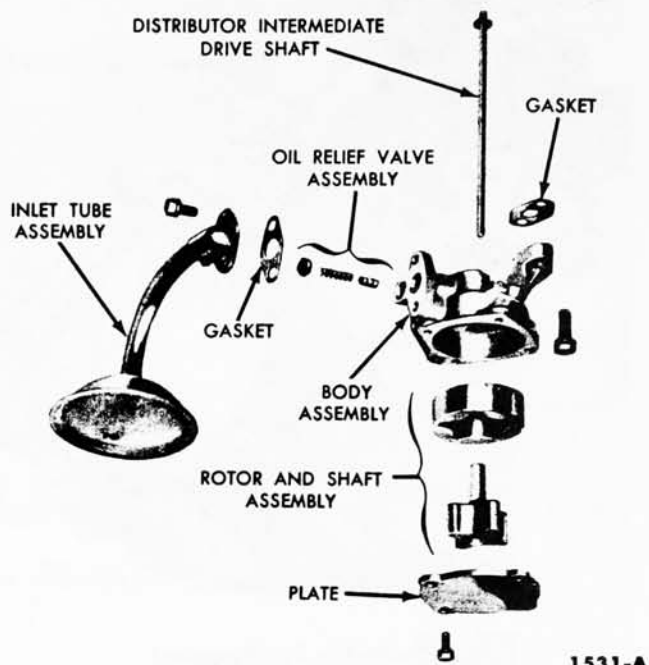

1531-A

FIG. 32—Oil Pump Assembly

the cover and tighten the cover retaining screws to 6-9 foot-pounds torque.

4. Position a new gasket and the oil inlet tube on the oil pump and install the retaining bolts.

5 ENGINE ASSEMBLY (ENGINE REMOVED)

CAMSHAFT BEARINGS

Camshaft bearings are available pre-finished to size for standard and 0.015-inch undersize journal diameters. The bearings are not interchangeable from one bore to another. The bearings must be in-

stalled in their respective bores.

1. Position the new bearing at the bearing bore, and press it in place with the tool shown in Fig. 22. Align the oil holes in the bearing with the oil holes in the cylinder block when the bearings are in-

stalled. Be sure the camshaft front bearing is installed 0.005-0.020 inch below the front face of the cylinder block (Fig. 33).

2. Clean out the camshaft rear bearing bore plug recess thoroughly.

3. Coat the flange of a new plug with water resistant sealer and install it with the flange facing in (Fig. 34).

INSTALL FRONT BEARING 0.005-0.020-INCH BELOW FRONT FACE OF BLOCK



1544-B



Tool—T58P-6266-A

1545-A

FIG. 34—Camshaft Rear Bearing Bore Plug Installation



BUY IT NOW!

[Click Here To Order](#)



4. Drive the plug in until it is flush or slightly below the casting surface.

CAMSHAFT

The camshaft and related parts are shown in Fig. 35.

Oil the camshaft and apply Lubriplate to all lobes, then carefully slide it through the bearings.

CRANKSHAFT

The crankshaft and related parts are shown in Fig. 36.

1. Be sure that the rear journal oil seal grooves are clean, then install a new rear journal oil seal in the block (Fig. 37) and rear main bearing cap (Fig. 38). After installation, cut the ends of the seals flush.

2. If the crankshaft main bearing journals have been refinished to a definite undersize, install the correct undersize bearings. Be sure the bearing inserts and bearing bores are clean. Foreign material under the inserts may distort the bearing and cause a failure.

Place the upper main bearing inserts in position in the bore with the

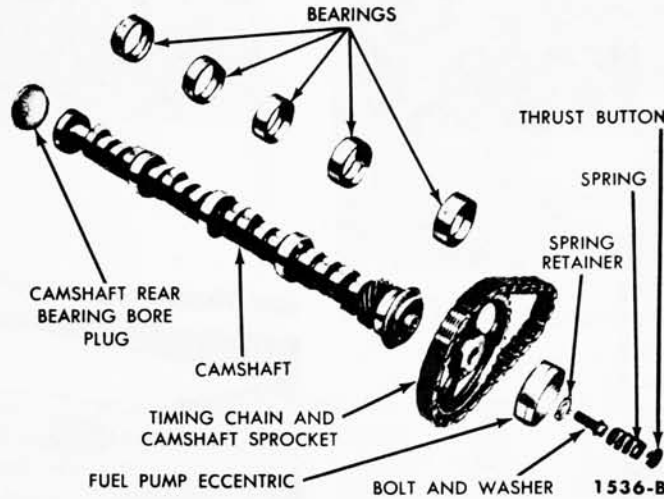
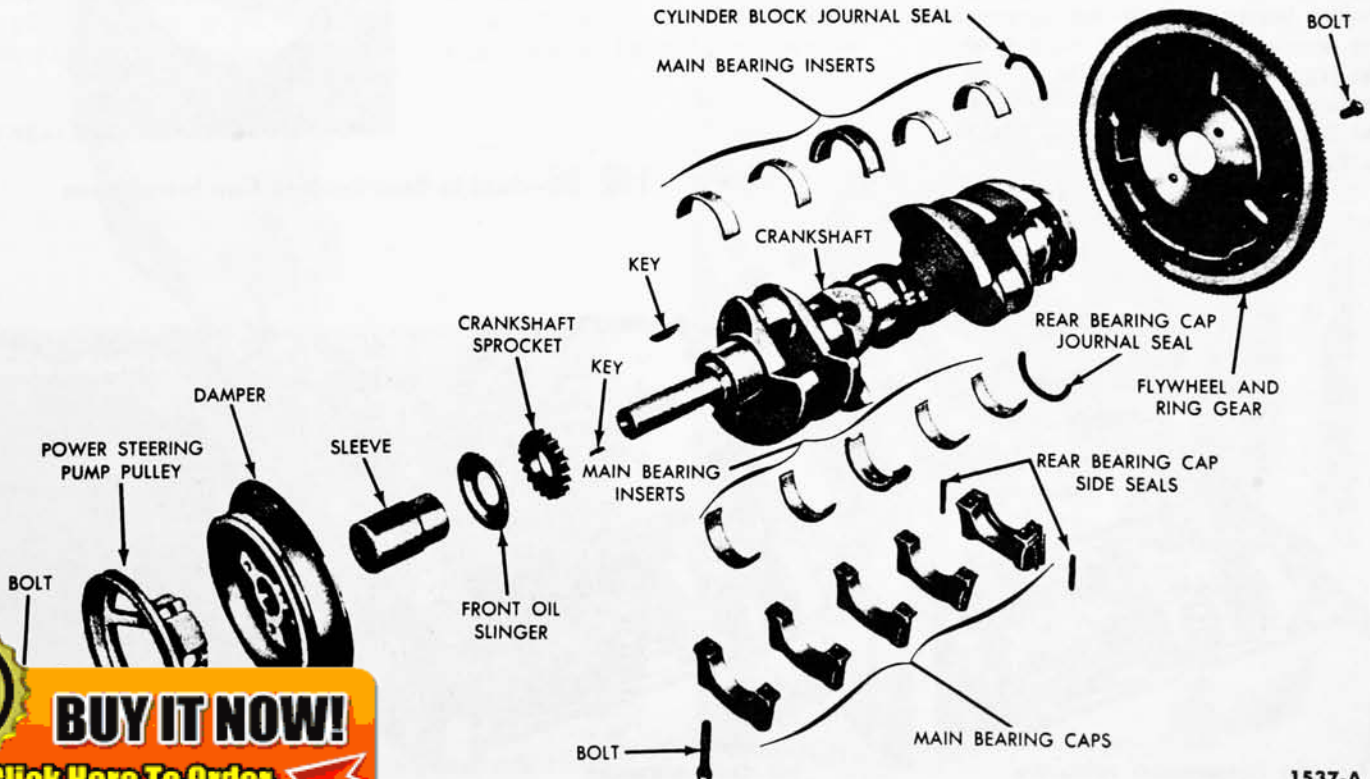

FIG. 35—Camshaft and Related Parts



1537-A



BUY IT NOW!

Click Here To Order



Parts

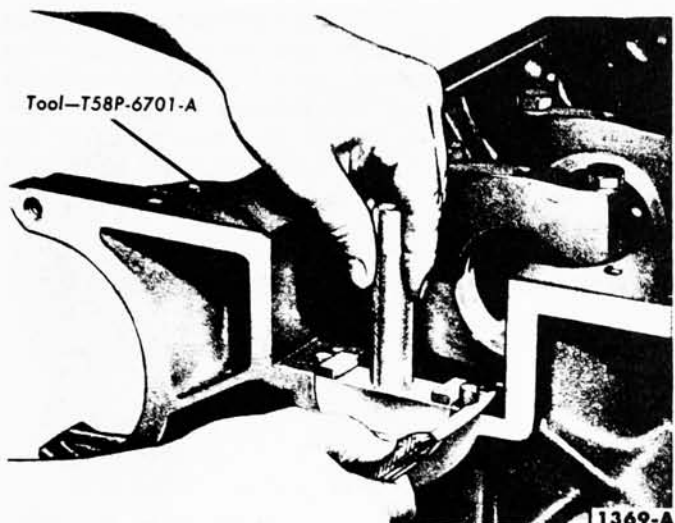

FIG. 37—Seal to Block Installation

tang fitting in the slot provided.

3. Install the lower main bearing inserts in the bearing caps.

4. Carefully lower the crankshaft into place. **Be careful not to damage the bearing surfaces.**

5. Check the clearance of each main bearing following the procedure under "Main Bearing Replacement."

6. If the bearing clearances are satisfactory, apply a light coat of engine oil to the journals and bearings, then install all the bearing caps, except the thrust bearing cap (No. 3 bearing). **Main bearing caps are numbered 1 thru 5 starting at the front of the engine. The arrows on the cap should be pointed toward the front of the engine.** Tighten the bearing cap bolts to specifications.

7. Install the thrust bearing cap with the bolts finger tight. Pry the

crankshaft forward against the thrust surface of the upper half of the bearing (Fig. 39). Hold the crankshaft forward and pry the thrust bearing cap to the rear (Fig. 39). This will align the thrust surfaces of both halves of the bearing. Retain the forward pressure on the crankshaft, and tighten the cap bolts to specifications (Fig. 39).

8. Force the crankshaft toward the rear of the engine. Install a dial indicator so the contact point rests against the crankshaft flange and the indicator axis is parallel to the

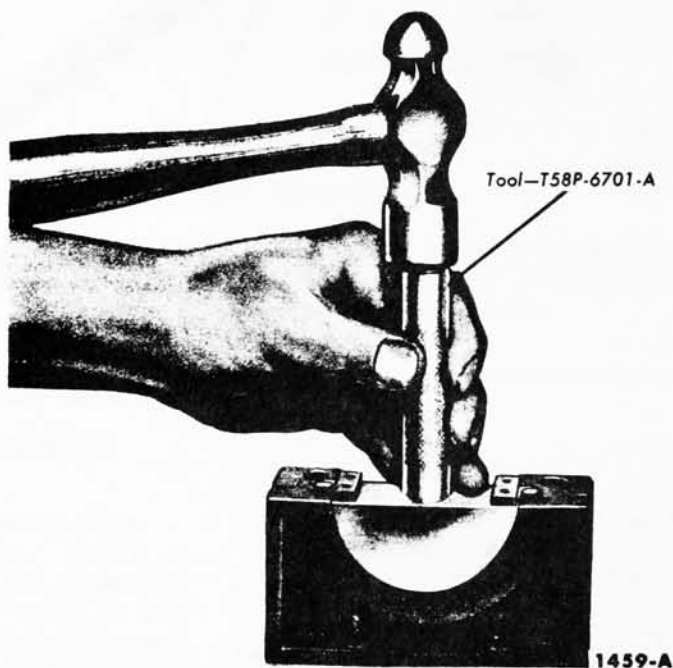
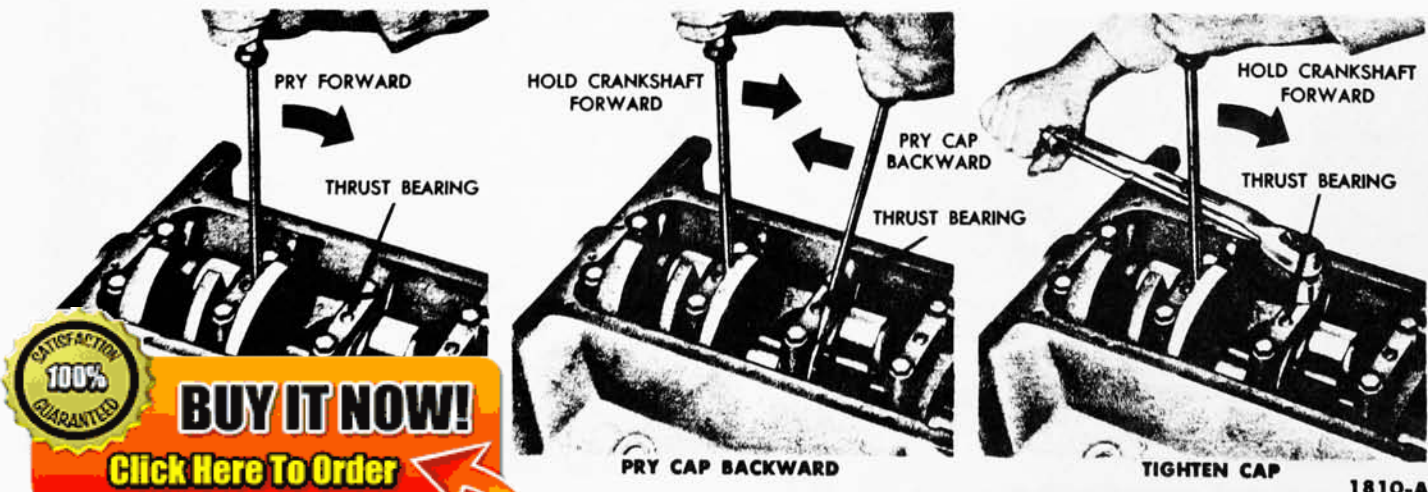

FIG. 38—Seal to Rear Bearing Cap Installation



100% SATISFACTION GUARANTEED

BUY IT NOW!

[Click Here To Order](#)

PayPal | American Express | Discover | MasterCard | VISA

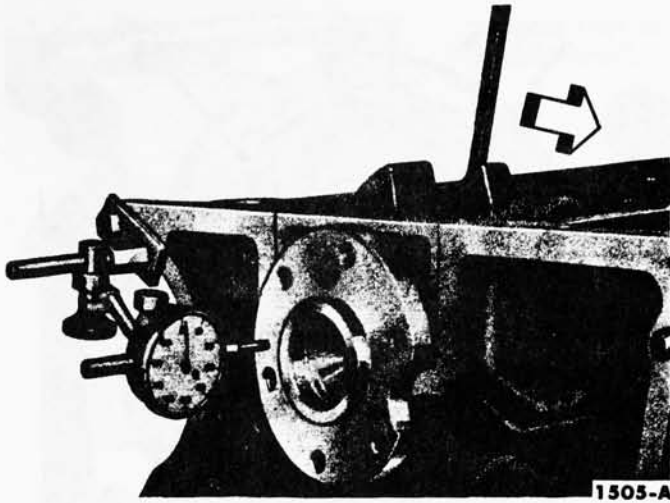

FIG. 40—Crankshaft End Play

crankshaft axis (Fig. 40). Set the dial on zero, then push the crankshaft forward and note the reading on the dial.

9. If the end play exceeds the wear limit, replace the thrust bearing. If the end play is less than the minimum limit, inspect the thrust bearing faces for scratches, burrs, nicks, or dirt. If the thrust faces are not defective or dirty, they probably were not aligned properly. Install the thrust bearing and align the faces following the recommended procedure (step 7), then recheck the end play.

10. Dip the rear bearing cap side

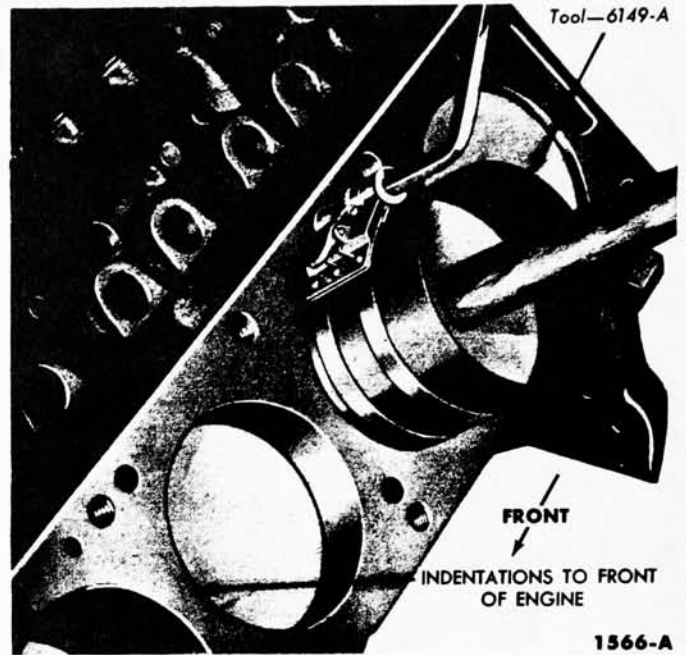

FIG. 41—Piston Installation

seals in light engine oil, then immediately install them in the grooves. It may be necessary to tap the seals into place for the last 1/2 inch of travel. Do not cut the seal projecting ends. Do not use sealer on the side seals, the seals are designed to expand when dipped in oil. Using sealer may retard this expansion.

11. Check the rear main bearing cap side seals for leaks by squirting

a few drops of oil into the parting lines between the bearing cap and the cylinder block from the outside. Blow compressed air against the seals from the inside of the block. If air bubbles appear in the oil, it indicates possible oil leakage. The above test should not be performed on newly installed seals until sufficient time has been allowed for the seals to expand into the seal grooves.

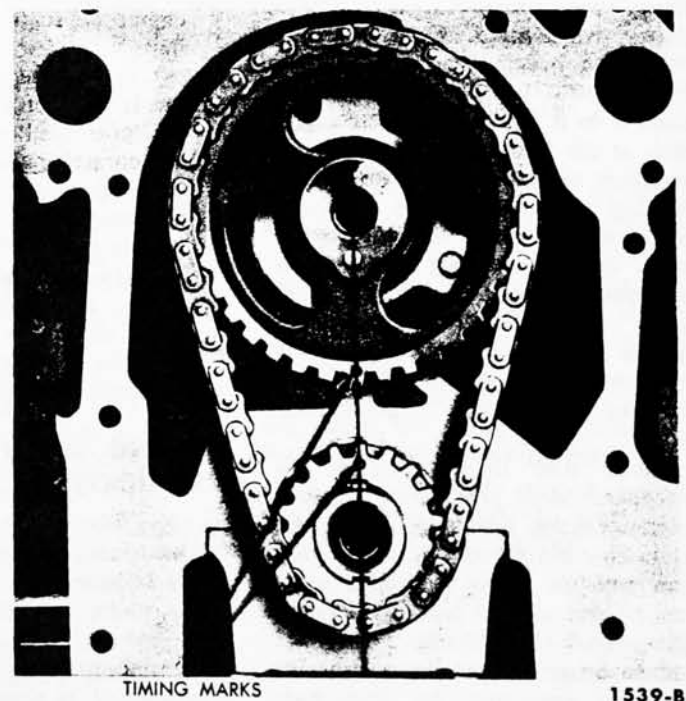

FIG. 43—Aligning Timing Marks



BUY IT NOW!

Click Here To Order



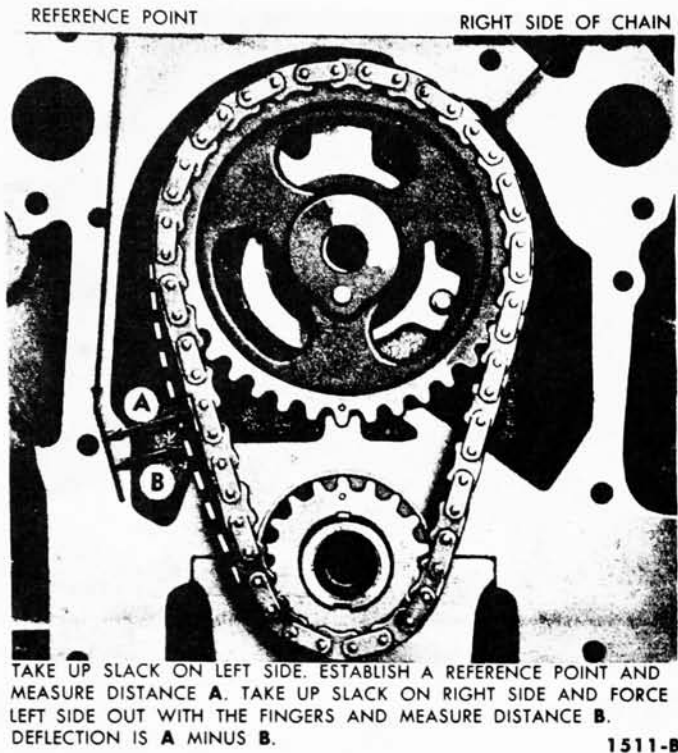

FIG. 44—Timing Chain Deflection

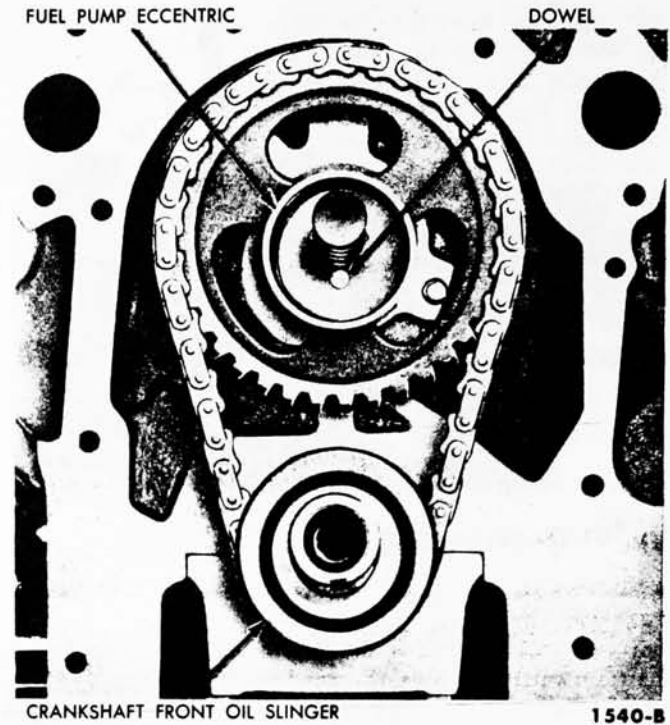

FIG. 45—Fuel Pump Eccentric and Front Oil Slinger Installed

CONNECTING ROD ASSEMBLIES

1. Turn the engine on the work stand so that the front end is up.

2. Oil the piston rings, pistons, and cylinder walls with light engine oil.

3. Be sure to install the pistons in the same cylinders from which they were removed, or to which they were fitted. Each connecting rod and bearing cap are numbered from 1 to 4 in the right bank and from 5 to 8 in the left bank, beginning at the front of the engine. The numbers on the connecting rod and bearing cap must be on the same side when installed in the cylinder bore. If a connecting rod is ever transposed from one block or cylinder to another, new bearings should be fitted and the connecting rod should be numbered to correspond with the new cylinder number.

Make sure the ring gaps are properly spaced around the circumference of the piston. Install a piston compressor on the piston

toward the front of the engine. When installed, the bearing lock slots in the connecting rod should be toward the outside of the engine.

4. Check the clearance of each bearing following the procedure under "Connecting Rod Bearing Replacement."

5. If the bearing clearances are to specifications, apply a light coat of engine oil to the journals and bearings.

6. Turn the crankshaft throw to the bottom of its stroke, then push the piston all the way down until the connecting rod bearing seats on the crankshaft journal. Install the connecting rod cap, then tighten the nuts to specifications.

7. After the piston and connecting rod assemblies have been installed, check the side clearance between the connecting rods on each crankshaft journal (Fig. 42).

TIMING CHAIN AND SPROCKETS

1. Place the key in position in the slot on the crankshaft.

2. Position the sprockets and timing chain on the camshaft and crankshaft (Fig. 21). Be sure the timing marks on the sprockets are positioned as shown in Fig. 43.

3. Rotate the crankshaft in a clockwise direction (as viewed from

the front) to take up the slack on the left side of the chain.

4. Establish a reference point on the block and measure from this point to the chain (Fig. 44). Rotate the crankshaft in the opposite direction to take up the slack on the right side of the chain, then force the left side of the chain out with the fingers and measure the distance between the reference point and the chain. The deflection is the difference between the two measurements.

5. If the deflection exceeds $\frac{1}{2}$ inch, replace the timing chain and/or sprockets.

6. Install the fuel pump eccentric (Fig. 45), and the camshaft sprocket cap screw and thrust button spring retainer. Tighten the sprocket cap screw to specifications. Install the camshaft thrust button spring and thrust button. Install the crankshaft front oil slinger.

CYLINDER FRONT COVER AND FRONT OIL SEAL

FRONT OIL SEAL REPLACEMENT

It is good practice to replace the oil seal each time the cylinder front cover is removed.

1. Drive out the old seal with a pin punch, then clean out the recess in the cover.

2. Coat a new seal with grease,

100% SATISFACTION GUARANTEED

BUY IT NOW!

Click Here To Order

INSTALL THE BEST WITH THE BEST

PayPal | American Express | Discover | MasterCard | VISA

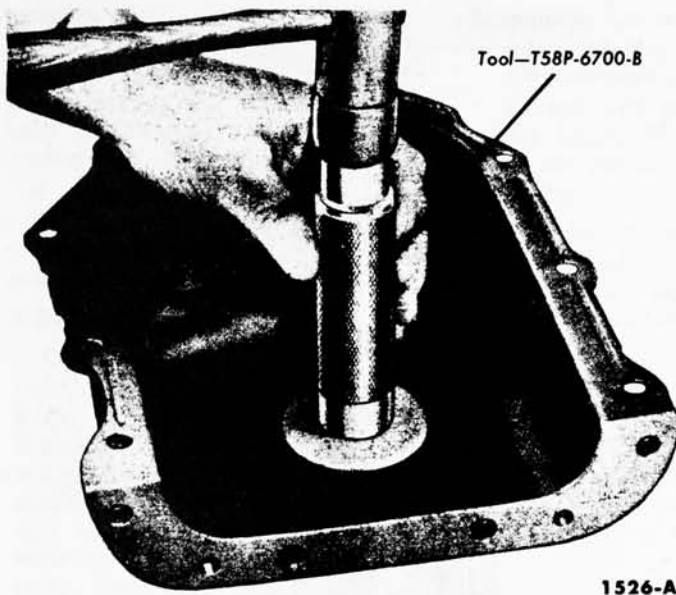

FIG. 46—Oil Seal Installation

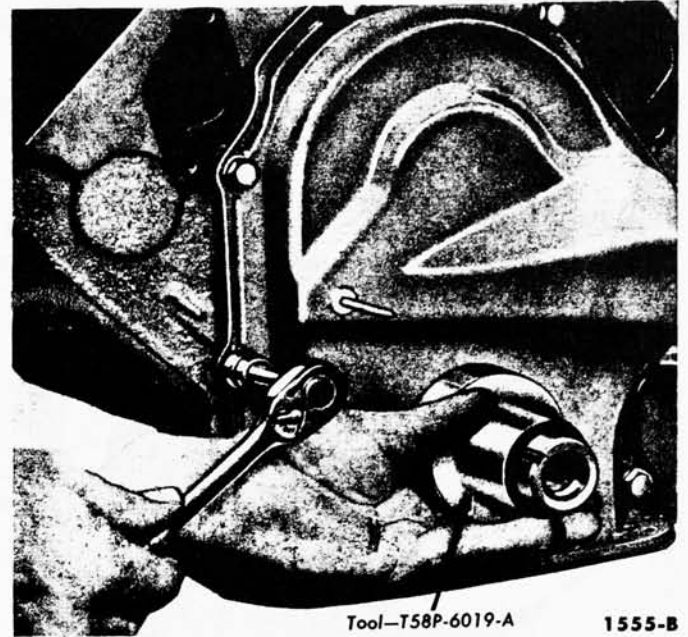

FIG. 47—Cylinder Front Cover Alignment



FIG. 48—Crankshaft Sleeve Installation

then install the seal (Fig. 46). Drive the seal in until it is fully seated in the recess. Check the seal after installation to be sure the spring is properly positioned in the seal.

CYLINDER FRONT COVER INSTALLATION

1. Clean the cylinder front cover and the cylinder block gasket surfaces.

2. Coat the gasket surface of the block and cover and the cover bolt threads with sealer. Position a new gasket on the block.

3. Install the alignment pilot tool on the cylinder front cover so the keyway in the pilot aligns with the key in the crankshaft. Position the cover and pilot over the end of the crankshaft and against the block (Fig. 47).

tighten the cover bolts to specifications. Remove the pilot.

5. Lubricate the crankshaft with a white lead and oil mixture and lubricate the oil seal rubbing surface with grease.

6. Install the crankshaft sleeve (Fig. 48) with the smallest O.D. end into the cylinder front cover bore if the sleeve is stepped down (different O.D. on each end).

7. Line up the damper keyway with the key on the crankshaft, then install the damper on the crankshaft (Fig. 49).

8. Install the damper cap screw and washer, and tighten the screw to specifications.

On an engine with a separate power steering pulley, install the

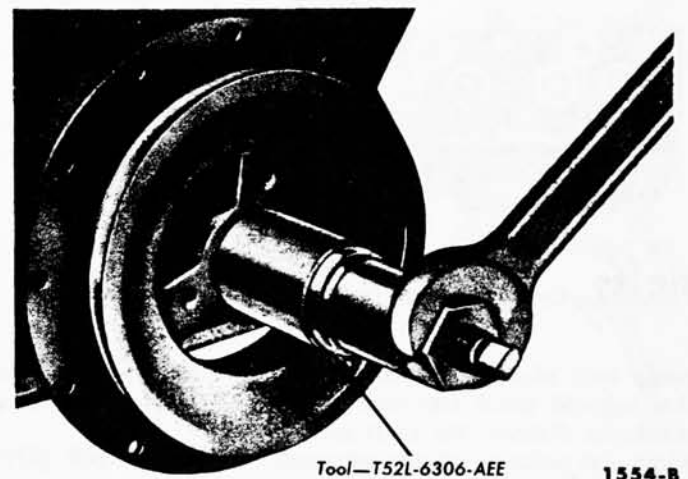

FIG. 49—Crankshaft Damper Installation

pulley on the crankshaft damper. Tighten the screws to specifications.

9. Clean the water pump gasket surfaces and apply sealer. Position new gaskets on the pump and install the water pump, pulley, and fan as an assembly.

On an engine with a power steering pump, the pump is retained by the water pump retaining bolts.

10. Using a new gasket, install the fuel pump. Install the generator, brackets, and drive belts.

OIL PUMP AND OIL PAN

1. Invert the engine on the work stand. Position the oil pump drive shaft into the oil pump socket. With the shaft firmly seated in the distributor socket, position the oil

100% SATISFACTION GUARANTEED

BUY IT NOW!

Click Here To Order

PayPal American Express Discover Novus MasterCard VISA

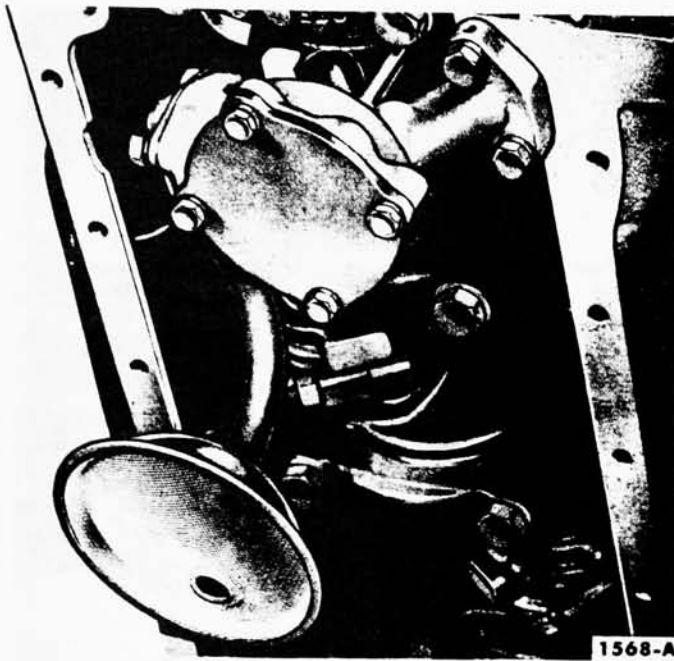

FIG. 50—Oil Pump and Inlet Tube Installed

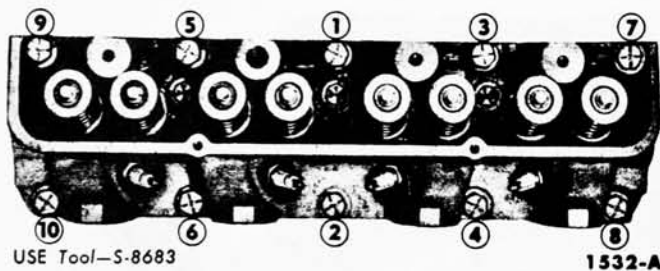

FIG. 52—Cylinder Head Bolt Tightening Sequence

pump into place. The stop on the shaft should touch the roof of the crankcase. Remove the shaft and oil pump and position the stop as necessary.

2. With the stop properly positioned, insert the oil pump drive shaft into the oil pump.

3. Position a new gasket on the pump housing and install the pump and shaft as an assembly (Fig. 50).

4. Position a new gasket on the oil pan and place the oil pan assembly on the block. Install the retaining screws and tighten them, from the center outward, to specifications.

FLYWHEEL

Position the flywheel on the

100% SATISFACTION GUARANTEED
BUY IT NOW!
 Click Here To Order



the pressure plate. Tighten the retaining bolts to specifications.

OIL FILTER AND ADAPTER

The oil filter assembly is shown in Fig. 51.

1. Clean the oil filter adapter gasket surfaces.

2. Apply sealer to a new adapter gasket, and install the adapter assembly and gasket.

3. Clean the adapter filter recess. Coat the gasket on a new filter with oil. Then place the filter in position on the adapter. Hand tighten the filter until the gasket contacts the adapter face, and then advance it ½-turn.

CYLINDER HEADS

1. Clean the cylinder head and block gasket surfaces. Guided by the word "Front" on the gasket, install the head gasket over the cylinder head dowels. Do not apply sealer to the gasket or gasket surface of the head or block.

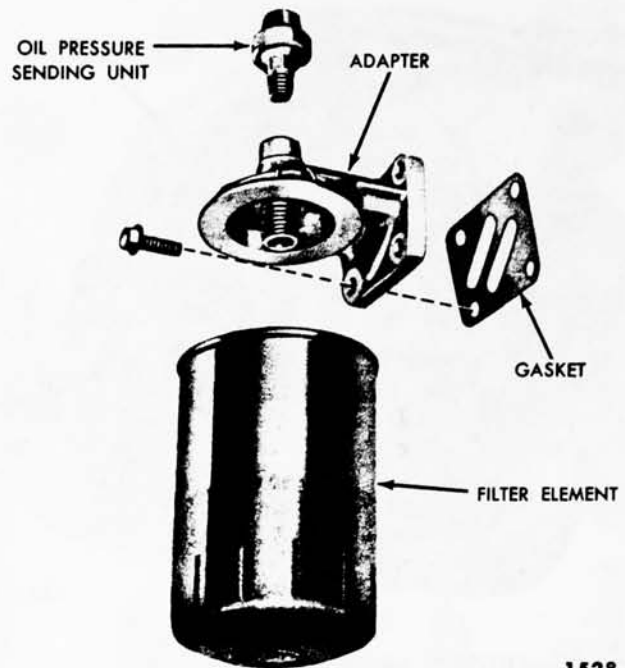

FIG. 51—Oil Filter Assembly

2. Place the cylinder head on the engine, then remove the holding fixtures. Coat the head bolt threads with water resistant sealer, and then install the bolts.

3. The cylinder head bolt tightening procedure is performed in three progressive steps. Tighten the bolts to 60-70 foot-pounds torque in the proper sequence (Fig. 52), then tighten them to 70-80 foot-pounds torque in the same sequence. Finally, tighten the bolts to 80-90 foot-pounds torque in the same sequence. **After the cylinder head bolts have been tightened to specifications, the bolts should not be disturbed.**

4. Coat the mating surfaces of the exhaust manifold with a light film of graphite grease.

5. On the right exhaust manifold, using a new gasket, install the automatic choke air chamber cover on the manifold. **Be sure the cover is securely fastened.** Position the exhaust gas control valve over the muffler inlet pipe studs of the manifold, using a new gasket on each side of the valve. Temporarily tie the valve to the exhaust manifold.

6. Position a new gasket over the muffler inlet pipe studs of the left exhaust manifold.

7. Position the exhaust manifold on the cylinder head and install the

retaining bolts and tab washers. Tighten the retaining bolts to 23-28 foot-pounds torque, working from the center to the ends. Lock the bolts by bending one tab of the washer over a flat on the bolt.

8. Install the spark plugs.

9. Position the baffle plate in the valve push rod chamber. Press it into place with the hands (Fig. 53).

VALVE LIFTERS

Coat the outside of each valve lifter with engine oil to provide initial lubrication. Do not fill the lifters with oil. The lifters will fill much faster after the engine is started, if they are free of any oil film which may cause an oil seal between the plunger and the lifter body. Place each lifter in the bore from which it was removed.

INTAKE MANIFOLD AND DISTRIBUTOR

The intake manifold assembly is shown in Fig. 54.

1. Clean the mating surfaces of the intake manifold, cylinder heads, and cylinder block.

2. Coat the intake manifold and cylinder block cork seal surfaces with oil resistant sealer.

3. Position new seals on the cylinder block and new gaskets on the

cylinder heads with the gasket resting on the cylinder head gasket tabs. Be sure the holes in the gaskets are aligned with the holes in the cylinder heads. The correct installation of the gaskets and seals are shown in Fig. 55.

4. Install the eye bolts in the intake manifold and attach the engine lifting sling and carefully lower the intake manifold on the engine (Fig. 15).

5. Position the intake manifold by inserting the distributor in place. After the intake manifold is in place, run a finger around the cork seal area to make sure the seals are

in place. If the seals are not in place, remove the intake manifold and reposition the seals.

6. Start the water pump by-pass hose on the intake manifold.

7. Be sure the holes in the manifold gaskets and manifold are in alignment. Install the manifold retaining bolts and tighten them to specifications, working from the center to the ends.

8. Remove the distributor and the engine lifting sling and eye bolts. Install the radiator supply tank.

9. Install the valve push rods in their proper sequence, making sure the lower ends of the rods are posi-

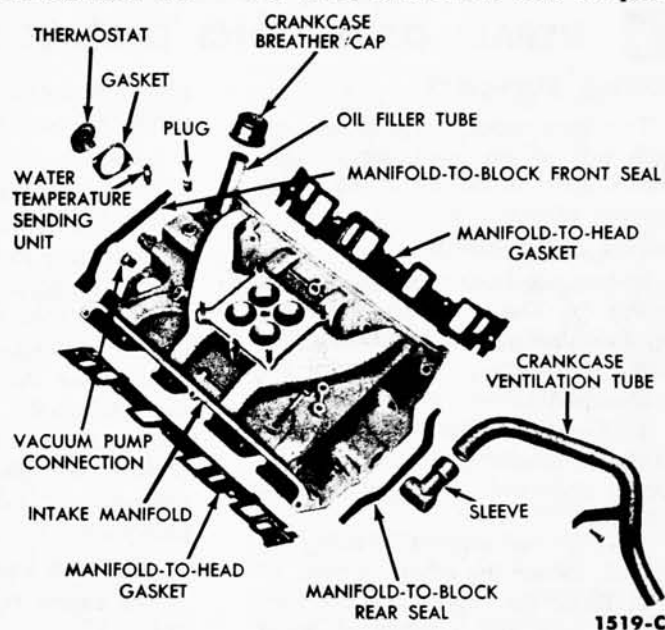

FIG. 54—Intake Manifold Assembly

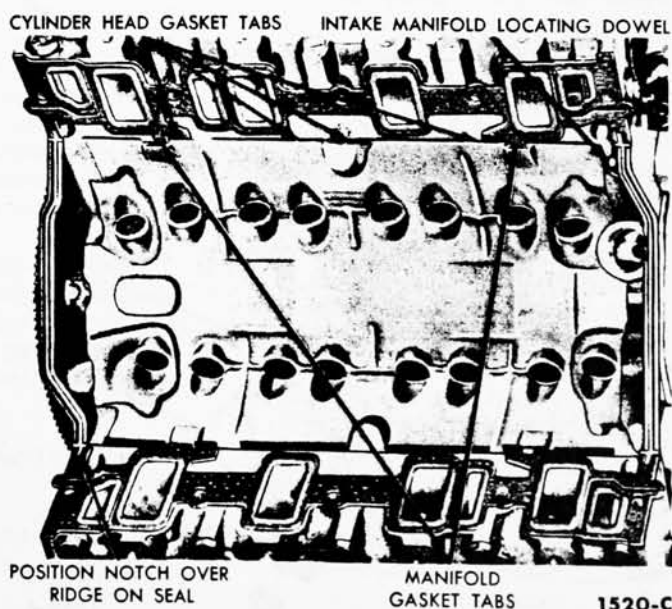

FIG. 55—Intake Manifold Gaskets and Seals Installation



BUY IT NOW!

Click Here To Order



tioned in the lifter push rod cup.

10. Crank the engine until the No. 1 piston is on T.D.C. at the end of the compression stroke.

11. Rotate the crankshaft damper an additional 45°.

12. Install the right valve rocker arm shaft assembly and the baffle plate on the cylinder head with the valve push rods in place and the rocker shaft support bolts finger tight. **Be sure the shaft is turned so that the oil holes are to the bottom.**

13. Starting at the No. 4 cylinder, tighten the bolts in sequence, two turns at a time, until the supports fully contact the cylinder head.

Tighten the bolts in sequence to specifications.

14. Starting at the No. 5 cylinder, follow the same procedure for the left valve rocker arm shaft support bolts. The additional time consumed in this procedure will permit the hydraulic lifters to leak down. This will minimize the possibility of bending the push rods, valves, or the rocker arms. **Be sure that the hydraulic lifters have leaked down to their normal operating position before cranking the engine. This is necessary in order to avoid possible damage to the valves, push rods, or valve rocker arms.**

15. Install the automatic choke heat tube.

16. Rotate the crankshaft damper until the No. 1 piston is on T.D.C., then position the distributor in the block with the rotor at the No. 1 firing position and the breaker points open. Install the hold down clamp.

17. Connect the distributor vacuum line. Install the distributor cap. Install the valve rocker arm covers. Connect the spark plug wires. Be sure the spark plug wires for No. 7 and 8 cylinders are properly positioned. See Fig. 8—Part 2-1. Install the vacuum booster pump line and the carburetor fuel inlet line.

6 REPAIR OPERATIONS (ENGINE INSTALLED)

ENGINE SUPPORTS

The front supports are located on each side of the crankcase and the rear support is located at the transmission extension housing.

ENGINE FRONT SUPPORT

The engine front support is shown in Fig. 56. The procedures given apply to either a right or left installation.

Removal

1. Remove the insulator assembly to engine retaining bolts, and insulator to underbody retaining nut and washer.

If only one support is being removed, loosen the other support.

2. Raise the engine about 1 inch with a jack and a block of wood

placed under the oil pan, then remove the insulator assembly.

Installation

1. Position the insulator assembly. Install, but do not tighten, the insulator to engine lockwashers and bolts. If both supports have been removed, install the bolts on the opposite side before proceeding with step 2.

2. Lower the engine, then install the underbody to insulator lockwasher and nut and tighten the nut to 40-45 foot-pounds torque. Tighten the insulator to engine bolts to 35-40 foot-pounds torque.

ENGINE REAR SUPPORT

The engine rear support is shown in Fig. 57.

Removal

1. Remove the support retainer bolts and washers, and remove the support assembly to underbody bolts.

2. Raise the extension housing slightly to relieve the pressure on the support assembly. Remove the support assembly and retainer.

Installation

1. Raise the extension housing enough to position the support assembly and retainer. Install the support retainer to extension housing flat washers, lockwashers, and bolts, the support assembly to underbody bolts, lockwashers and nuts.

2. Remove the jack from the extension housing, then tighten the support retainer bolts to 25-30 foot-

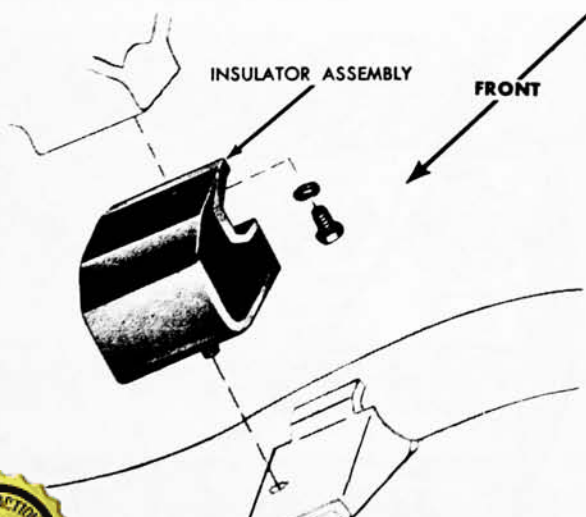

SPACER

1745-A

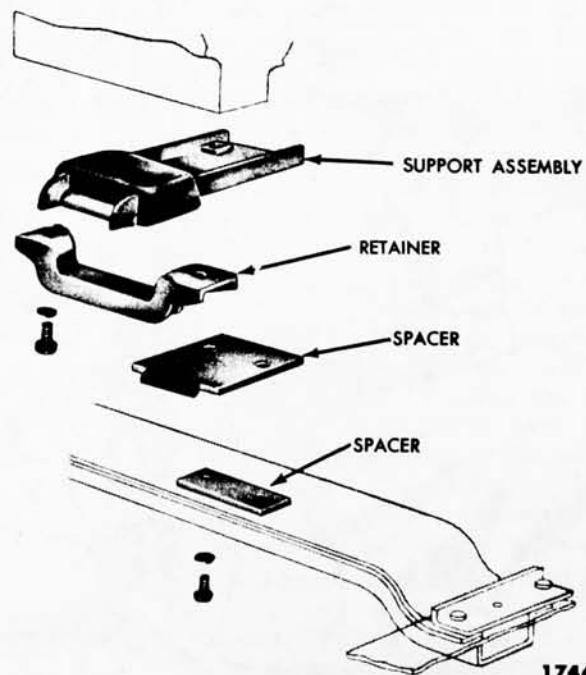

1746-A

FIG. 57—Engine Rear Support

100% SATISFACTION GUARANTEED

BUY IT NOW!

Click Here To Order

PayPal American Express Discover Novus MasterCard VISA

pounds torque, and the support assembly nuts to 40-45 foot-pounds torque.

INTAKE MANIFOLD

REMOVAL

1. Drain the cooling system. Remove the air cleaner.

2. On a car with a manual-shift transmission, disconnect the accelerator rod at the carburetor. Remove the accelerator retracting spring.

3. On a car with an automatic transmission, disconnect the accelerator rod at the carburetor. Remove the accelerator cross shaft bracket from the intake manifold and position it out of the way.

4. Remove the carburetor fuel inlet line, the windshield wiper vacuum line, and the vacuum booster pump line.

5. Disconnect the coil high tension lead, and the coil wires at the coil. Disconnect the oil pressure sending unit wire at the sending unit. Remove the wire loom from the retaining clips on the left valve rocker arm cover and position it out of the way.

6. Disconnect the spark plug wires at the spark plugs and remove the wires from the ignition harness brackets on the valve rocker arm covers. Remove the distributor cap and spark plug wire assembly. Disconnect the distributor vacuum line at the distributor.

7. Disconnect the radiator upper hose at the radiator supply tank, then remove the supply tank. Remove the heater hose at the intake manifold, and the water temperature sending unit wire at the sending unit.

8. Remove the battery ground strap retaining screw from the thermostat housing. Slide the clamp on the water pump by-pass hose toward the water pump. Remove the automatic choke heat tube. Disconnect the crankcase ventilation tube from the intake manifold.

9. Clean the outside of the valve rocker arm covers and remove the covers.

10. Complete the removal procedure by following steps 5 thru 9 under "Intake Manifold and Distributor" on page 1-30.

INSTALLATION

1. Follow steps 1 thru 17 under "Crankshaft Damper"

3. Install the wire loom in the retaining clips on the left valve rocker arm cover. Connect the oil pressure sending unit wire, the coil high tension leads, and the coil wires.

4. On a car with an automatic transmission, install the accelerator cross shaft bracket. Then connect the accelerator rod.

5. On a car with a manual-shift transmission, install the accelerator retracting spring and connect the accelerator rod.

6. Fill and bleed the cooling system. Install the air cleaner.

CYLINDER HEADS

REMOVAL

1. Remove the intake manifold and distributor following the procedure in this section.

2. Remove the exhaust manifolds. If the left cylinder head is to be removed, remove the ignition coil.

3. Remove the cylinder head bolts, and then install the cylinder head holding fixtures (Fig. 18).

4. Lift the cylinder heads off the block. **Do not pry between the head and the block.** Remove and discard the cylinder head gasket.

INSTALLATION

1. Clean the cylinder head and cylinder block gasket surfaces. Guided by the word "FRONT" on the gasket, install the gasket over the cylinder head dowels. Do not apply sealer to the gasket or gasket surface of the head or block.

2. Place the cylinder head on the engine, then remove the holding fixture. Coat the head bolt threads with water resistant sealer, then install the bolts.

3. Tighten the bolts to 60-70 foot-pounds torque in the sequence shown in Fig. 52, and then tighten them to 70-80 foot-pounds torque in the same sequence. Finally, tighten the bolts to 80-90 foot-pounds torque in the same sequence.

4. Install the exhaust manifolds.

5. Install the intake manifold, valve rocker arm shaft assembly, and distributor following steps 1 thru 17 under "Intake Manifold and Distributor" on page 1-43.

CRANKSHAFT DAMPER

REMOVAL

1. Drain the cooling system. Remove the hood, radiator supply tank, and the radiator.

2. Remove the drive belts.

On a car with power steering, re-

move the power steering pump pulley from the crankshaft damper.

3. Remove the large cap screw and washer from the end of the crankshaft. Install the puller on the crankshaft damper (Fig. 19) and remove the damper.

INSTALLATION

1. Line up the damper keyway with the key on the crankshaft. Then install the damper on the crankshaft (Fig. 49).

2. Install the damper cap screw and washer, and tighten the screw to specifications.

On a car with power steering, install the power steering pump pulley on the damper. Tighten the screws to specifications.

3. Install the drive belts, the radiator, radiator supply tank, and hood. Fill and bleed the cooling system.

CYLINDER FRONT COVER AND TIMING CHAIN

REMOVAL

1. Drain the cooling system and the crankcase. Remove the hood, air cleaner, radiator, and radiator supply tank.

2. Disconnect the carburetor fuel inlet line, manifold vacuum line, the windshield wiper vacuum line, and the flexible line at the fuel pump.

3. Remove the fuel pump and gasket.

4. On a car equipped with power steering, disconnect the power steering pump bracket from the water pump, then wire the pump to the hood left hinge in a position that will prevent the oil from draining out.

5. Disconnect the heater hose at the water pump. Slide the water pump by-pass hose tube clamp toward the engine. Disconnect the drive belt adjusting arm at the water pump.

6. Loosen the generator mounting bolts at the generator. Remove the drive belt. Remove the generator support bolt at the water pump. Remove the water pump, drive belt adjusting arm, pulley, and fan as an assembly.

7. Remove the crankshaft damper and crankshaft sleeve. Remove the screws fastening the cylinder front cover to the block and oil pan, then remove the cylinder front cover. On a car equipped with an air conditioner, the compressor brackets are retained by cylinder front cover screws.

8. Discard the cylinder front cover gasket. Remove the oil pan.

9. Remove the crankshaft front oil slinger. Crank the engine until the timing marks on the sprockets are positioned as shown in Fig. 43. Re-

1. Follow steps 1 thru 17 under "Crankshaft Damper"

BUY IT NOW!

Click Here To Order

PayPal American Express Discover MasterCard VISA

move the camshaft thrust button and spring, the sprocket cap screw, the thrust button spring retainer, and the fuel pump eccentric.

10. Slide both sprockets and the timing chain forward, and remove the sprockets and timing chain as an assembly (Fig. 21).

INSTALLATION

1. Place the key in position in the slot on the crankshaft.

2. Position the sprockets and timing chain on the camshaft and crankshaft (Fig. 21). Be sure the timing marks on the sprockets are positioned as shown in Fig. 43.

3. Install the fuel pump eccentric, and the camshaft sprocket cap screw and thrust button spring retainer. Tighten the sprocket cap screw to specifications. Install the camshaft thrust button spring and thrust button. Install the crankshaft front oil slinger.

4. Clean the cylinder front cover, oil pan, and the block gasket surfaces.

5. Working from the front of the engine, position the oil pan on the engine block. Install, but do not tighten, the oil pan to engine block retaining bolts.

6. Replace the crankshaft front oil seal.

7. Coat the gasket surface of the block and cover and the cover bolt threads with sealer. Position a new gasket on the block.

8. Install the alignment pilot tool on the cylinder front cover so the keyway in the pilot aligns with the key in the crankshaft. Position the cover and pilot over the end of the crankshaft and against the block (Fig. 47).

9. Install the cylinder front cover bolts finger tight. Position the generator support bracket and the generator adjusting arm bracket, then install the bolts.

While pushing in on the pilot, tighten the cover bolts to specifications. Remove the pilot.

10. Install the oil pan to cylinder front cover bolts, then tighten all the oil pan bolts to specifications working from the center of the pan outward.

11. Install the fuel pump using a new gasket.

Remove the crankshaft sleeve,

inlet line, the flexible fuel line, the manifold vacuum line, and the windshield wiper vacuum line. Connect the heater hoses. Slide the water pump by-pass tube clamp forward on the tube.

15. Install the radiator, radiator supply tank, and the hood. Fill and bleed the cooling system. Connect the heater hose to the water pump. Operate the engine at fast idle and check all hose connections and gaskets for leaks.

CAMSHAFT

REMOVAL

1. Drain the cooling system and the crankcase. Remove the radiator, radiator supply tank, and the hood.

2. Remove the crankshaft damper, cylinder front cover, timing chain and sprockets, and the intake manifold following the procedures in this section.

3. Lift the hydraulic valve lifters from the cylinder block and place them in a rack so that they may be installed in their original bore. It is not necessary to remove the baffle plate from the valve push rod chamber floor to remove the valve lifters. **The internal part of each hydraulic valve lifter assembly are matched sets. Do not intermix the parts.** Keep the assemblies intact until they are to be cleaned.

4. Carefully remove the camshaft by pulling it toward the front of the engine.

INSTALLATION

1. Oil the camshaft and apply Lubriplate to the lobes, then carefully slide it through the bearings.

2. Install the hydraulic valve lifters in the bores from which they were removed. Install the baffle plate if it was removed.

3. Install the intake manifold, timing chain and sprockets, cylinder front cover, and the crankshaft damper following the procedures in this section.

4. Install the radiator, the radiator supply tank, and the hood. Fill and bleed the cooling system. Fill the crankcase with the proper grade and quantity of engine oil.

5. Start the engine and adjust the ignition timing. Operate the engine at fast idle and check all hose connections and gaskets for leaks.

HYDRAULIC VALVE LIFTER REPLACEMENT

To remove one or all of the hydraulic valve lifters:

1. Remove the air cleaner.

If all the lifters are to be removed, or if a lifter on the right bank of the engine is to be removed, remove the choke heat tube.

2. Disconnect the spark plug wires at the plugs, and remove the rocker arm cover(s) and gasket(s).

3. Remove the valve rocker arm shaft assembly by following step 5 under "Intake Manifold and Distributor" on page 1-30.

4. Remove the valve lifters through the push rod openings with a magnet.

5. Install the new valve lifter(s) through the push rod opening with a magnet.

6. Install the push rods in their original bores.

7. Install the valve rocker arm shaft assembly by following steps 10 thru 14 under "Intake Manifold and Distributor" on page 1-43.

8. Install the valve rocker arm cover(s) and gasket(s). Install the choke heat tube if it was removed. Connect the spark plug wires and install the air cleaner.

The preceding procedure can not be used if the hydraulic valve lifters are stuck in their bore by excessive varnish, etc. In this case it will be necessary to remove the intake manifold following the procedure in this section. After the intake manifold has been removed, remove the hydraulic valve lifter with the tool shown in Fig. 17.

FLYWHEEL

REMOVAL

1. Disconnect the transmission from the engine and slide it to the rear as outlined in Group 3 (manual-shift transmissions) or Group 4 (automatic transmission).

2. On a manual-shift transmission, mark the pressure plate cover and flywheel to facilitate assembly, then loosen the cover to flywheel bolts evenly to release the pressure plate spring tension. Remove the pressure plate and cover assembly.

3. Remove the flywheel retaining bolts and remove the flywheel.

INSTALLATION

1. Install the flywheel on the crankshaft flange and install the retaining bolts. Tighten the bolts in sequence across from each other to specifications.

2. On a manual-shift transmission, install the pressure plate and cover assembly on the flywheel, and start the cover bolts. Use tool 7563

bel
an

Click Here To Order

PayPal American Express Discover MasterCard VISA

COAT GASKET WITH ENGINE OIL



FIG. 58—Oil Filter Replacement

to align the clutch disc, and then evenly tighten the cover bolts to specifications.

3. Connect the transmission to the engine as outlined in Group 3 (manual-shift transmissions) or Group 4 (automatic transmission).

OIL FILTER REPLACEMENT

1. Place a drip pan under the filter. Unscrew the filter from the adapter fitting. Clean the adapter filter recess.

2. Coat the gasket on the new filter with oil, then place the filter in position on the adapter (Fig. 58). Hand tighten the filter until the gasket contacts the adapter face, then advance it ½ turn.

3. Operate the engine at fast idle and check for leaks. If oil leaks are evident, perform the necessary repairs to correct the leakage. Check the oil level and fill the crankcase if necessary.

OIL PAN AND OIL PUMP

REMOVAL

1. Drain the cooling system and the crankcase. Disconnect the radiator upper hose at the radiator supply tank. Remove the oil pan retaining screws and lower the oil pan to the underbody cross member. Position the crankshaft so the counterweight will clear the oil pan and move the pan forward.

2. Remove the coil retaining bolts

and position the coil out of the way. Install the engine lifting brackets and sling. Raise the engine high enough to place tension on the engine mounts. Remove the engine front insulator to engine retaining bolts. Raise the engine high enough to permit removal of the oil pump retaining bolts, then remove the bolts. Remove the oil pan and the oil pump.

INSTALLATION

1. Raise the engine enough to allow installation of the oil pump and the oil pan. Position a new gasket on the oil pump housing and on the oil pan. Place the oil pump in the oil pan and position the oil pan on the underbody cross member. Insert the oil pump drive shaft into the oil pump housing and install the oil pump and shaft as an assembly. **Do not attempt to force the pump into position if it will not seat readily. The drive shaft hex may be misaligned with the distributor shaft. To align, rotate the intermediate shaft into a new position.** Tighten the oil pump retaining screws to 23-28 foot-pounds torque.

2. Hold the oil pan in place against the cylinder block and install a retaining screw on each side of the oil pan. Install the remaining screws and tighten them from the center outward to 12-15 foot-pounds torque.

3. Lower the engine, then install the engine right and left front support retaining bolts. Tighten the bolts to 40-45 foot-pounds torque. Remove the engine lifting bracket and sling. Install the coil and connect the radiator upper hose. Fill the cooling system. Fill the crankcase with the proper grade and quantity of engine oil. Operate the engine and check for leaks.

100% SATISFACTION GUARANTEED

BUY IT NOW!

Click Here To Order

PayPal American Express Discover MasterCard VISA

PART 1-3

THUNDERBIRD 430 SPECIAL V-8

Section	Page
1 Description.....	1-48
2 Engine Removal and Installation.....	1-52
3 Engine Disassembly (Engine Removed).....	1-54
4 Disassembly and Assembly of Component Parts.....	1-56

Section	Page
Valve Rocker Arm Shaft.....	1-56
Cylinder Heads.....	1-56
Hydraulic Valve Lifters..	1-57
Pistons and Connecting Rods.....	1-58
Oil-Vacuum Pump.....	1-59

Section	Page
5 Engine Assembly (Engine Removed).....	1-61
6 Repair Operations (Engine Installed).....	1-68
Engine Supports.....	1-68
Intake Manifold.....	1-68
Cylinder Heads.....	1-69
Crankshaft Damper.....	1-70
Cylinder Front Cover and Timing Chain.....	1-70
Camshaft.....	1-70
Hydraulic Valve Lifter Replacement.....	1-71
Flywheel.....	1-71
Oil Filter Replacement...	1-71
Oil Pan and Oil-Vacuum Pump.....	1-71

1 DESCRIPTION

The Thunderbird 430 Special V-8 engine (Fig. 1) has a 4.30-inch bore and a 3.70-inch stroke and a total piston displacement of 430 cubic inches. It has a compression ratio of 10.0:1. The patent plate symbol for the engine is "J."

MANIFOLDS

The intake manifold is water heated to assist in vaporizing the incoming fuel charge. The water passages are located beneath the fuel passages. Refer to "Cooling System" in this section for a description of the water circulation through the manifold.

The intake manifold has two sets of fuel passages, each with its own separate inlet connection to the carburetor (Fig. 2). The right side of the carburetor feeds Nos. 1, 4, 6 and 7 cylinders and the left side feeds Nos. 2, 3, 5, and 8 cylinders.

CYLINDER HEADS

The cylinder head assemblies contain the valves and the valve rocker arm shaft assembly. Valve guides are an integral part of the head. The intake and exhaust valve assemblies are the rotating-type which rotate each time the valve opens and closes. The

valve ports (Fig. 3) are water jacketed and are arranged so that no two exhaust valves are adjacent. The valves are arranged from front to rear on the right bank I-E-I-E-I-E-I-E, and on the left bank E-I-E-I-E-I-E-I.

CYLINDER BLOCK

The combination oil and vacuum pump is mounted to the engine block at the front. The distributor is located at the front of the engine and drives the oil pump through an intermediate drive shaft.

The combustion chambers are located in the cylinder block. The chambers are formed by casting the top of each bank at a 10° angle with

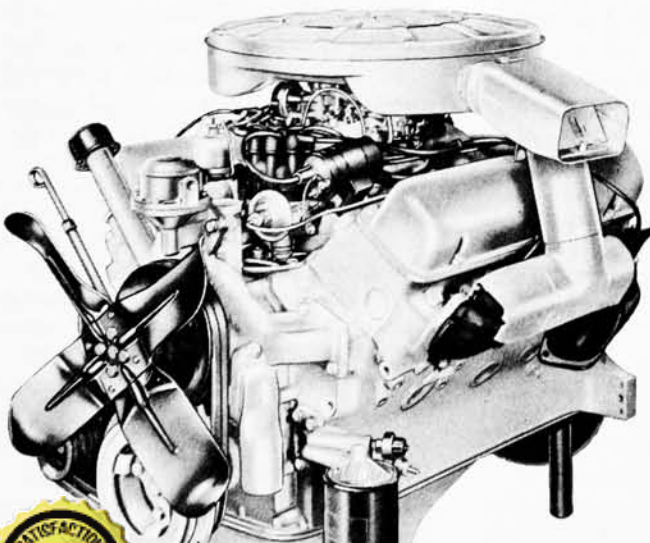

100% SATISFACTION GUARANTEED

BUY IT NOW!

Click Here To Order

PayPal American Express Discover Novus MasterCard VISA

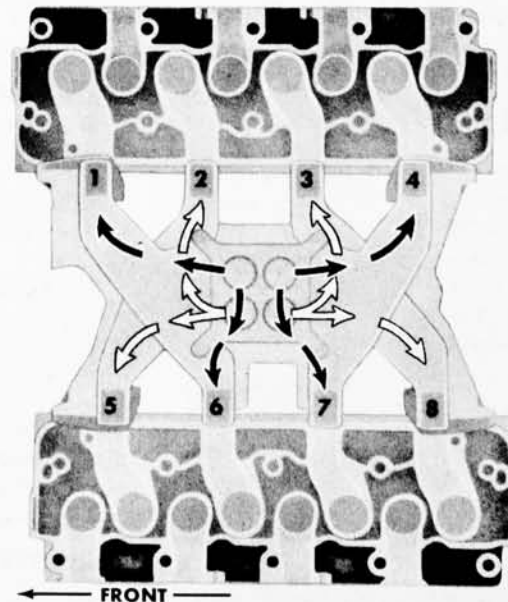

1869-A

1887-A

FIG. 2—Intake Manifold Fuel Passages