

1958

FORD TRUCK

SHOP MANUAL



BUY IT NOW!

Click Here To Order



PayPal

MasterCard

DISCOVER
NEWUS

MasterCard

VISA



License 2011747

• FORD MOTOR COMPANY

Copyright © 2011, Forel Publishing Company, LLC, Woodbridge, Virginia

All Rights Reserved. No part of this book may be used or reproduced in any manner whatsoever without written permission of Forel Publishing Company, LLC. For information write to Forel Publishing Company, LLC, 3999 Peregrine Ridge Ct., Woodbridge, VA 22192

1958 Ford Truck Shop Manual

EAN: 978-1-60371-067-1

ISBN: 1-60371-067-1

Forel Publishing Company, LLC

3999 Peregrine Ridge Ct.

Woodbridge, VA 22192

Email address: sales@ForelPublishing.com

Website: <http://www.ForelPublishing.com>



This publication contains material that is reproduced and distributed under a license from Ford Motor Company. No further reproduction or distribution of the Ford Motor Company material is allowed without the express written permission of Ford Motor Company.

Note from the Publisher

This product was created from the original Ford Motor Company's publication. Every effort has been made to use the original scanned images, however, due to the condition of the material; some pages have been modified to remove imperfections.

Disclaimer

Although every effort was made to ensure the accuracy of this book, no representations or warranties of any kind are made concerning the accuracy, completeness or suitability of the information, either expressed or implied. As a result, the information contained within this book should be used as general information only. The author and Forel Publishing Company, LLC shall have neither liability nor responsibility to any person or entity with respect to any loss or damage caused, or alleged to be caused, directly or indirectly by the information contained in this book. Further, the publisher and author are not engaged in rendering legal or other

advice, mechanical, electrical, or other expert assistance is required, the professional should be sought.



.....

CONTENTS



1958 FORD TRUCK SHOP MANUAL

.....

SERVICE DEPARTMENT
DIVISION



BUY IT NOW!

Click Here To Order



ILLINOIS

GROUP

ENGINES

1

IGNITION, FUEL, AND COOLING SYSTEMS

2

CLUTCHES AND TRANSMISSIONS

3

FORDOMATIC TRANSMISSION

4

REAR AXLES

5

CHASSIS SUSPENSION AND FRAMES

6

STEERING

7

BRAKES

8

GENERATING AND STARTING SYSTEMS

9

LIGHTS, INSTRUMENTS, AND ACCESSORIES

10

BODY MAINTENANCE AND REPAIR

11

DOORS, CABS, AND FRONT SHEET METAL

12

INTERIOR TRIM, SEATS, AND WINDOWS

13

MAINTENANCE, LUBRICATION, AND TOOLS

14

FOREWORD

This manual provides information for the proper servicing of 1958 Ford Trucks. Service procedures for the Courier and Ranchero are covered in 1958 Ford Car Shop Manual. The descriptions and specifications contained in this manual were in effect at the time the manual was approved for printing. The Ford Division of Ford Motor Company reserves the right to discontinue models at any time, or change specifications or design, without notice and without incurring obligation.

SERVICE DEPARTMENT
FORD DIVISION
FORD MOTOR COMPANY



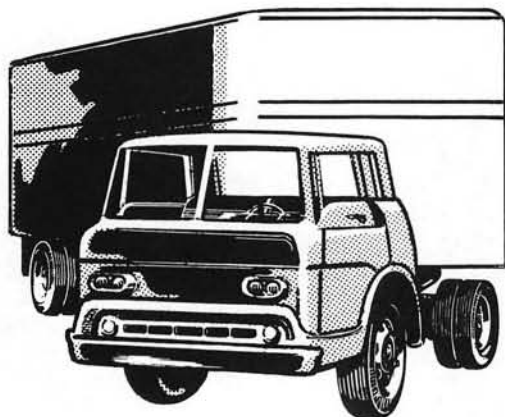

1958 FORD TRUCK SHOP MANUAL



GROUP 1 ENGINES

PART	Page
PART 1 GENERAL ENGINE SERVICE.....	1-2
PART 2 223 SIX ENGINE.....	1-20
PART 3 MEDIUM AND HEAVY DUTY V-8 ENGINES.....	1-43
PART 4 SUPER DUTY V-8 ENGINES.....	1-75
PART 5 SPECIFICATIONS.....	1-103



BUY IT NOW!

Click Here To Order

PayPal

Discover
Cards

DISCOVER
NOW!

MasterCard

VISA

PART 1 GENERAL ENGINE SERVICE

Section	Page
1 General Engine Trouble Shooting	1-2
2 Tune-Up	1-5
3 Manifolds, Cylinder Heads, and Valves.....	1-7
4 Timing Chain, Timing Gears, Camshaft, and Bearings	1-12
5 Flywheel, Crankshaft, Connecting Rods, Piston Assemblies, and Bearings	1-14
6 Cylinder Block	1-17
7 Oil Pan, Oil Pump, and Oil Cooler	1-18

The V-8 engines will be referred to as follows: medium duty engines

(272 and 292 cubic inch displacement) as MD V-8; heavy duty engines (272, 292, 302, and 332 cubic inch displacement) as HD V-8; and super duty engines (401, 477, and 534 cubic inch displacement) as SD V-8.

The following service procedures apply to all engines. The cleaning, inspection, repair, and overhaul procedures of the component engine parts apply after the parts have been removed from the engine, or in the case of a complete engine overhaul, after the engine has been disassembled.

For removal, disassembly, and installation procedures, refer to Part 2, 3, or 4.

The specifications for all engines are listed in Part 5.

1 GENERAL ENGINE TROUBLE SHOOTING

Poor engine performance can be caused by the need for a general engine tune-up, by gradual wear of engine parts or by a sudden parts failure. A good trouble diagnosis will indicate the need of a complete engine tune-up, individual adjustments, part(s) replacement or overhaul, or the need of a complete engine overhaul.

Engine performance complaints usually fall under one of the following basic headings: **engine will not crank; engine cranks normally, but will not start; engine starts, but fails to keep running; engine runs, but rough engine idle, poor accel-**

perature.

Table 1 is a general trouble shooting chart which lists basic engine troubles with procedures and checks to be performed to help isolate the cause of the trouble in a particular system. The reference after each check refers to that part of the manual which covers, in detail, checking procedures as well as corrections to be made in the various systems. When a particular trouble can not be traced to a definite system by a simple check, the possible systems that could be at fault are listed in the order of their probable occurrence; therefore, in most cases, the checks should be made in the order listed. Some consideration, however, should be given to logical order. For example, if the spark plugs are removed for testing and they are not the cause of the

trouble, and several checks later calls for a compression test, to save time, check the compression while the spark plugs are out.

Separate trouble shooting charts are included in the ignition, fuel, and cooling system sections of the manual. These charts list the basic troubles listed in Table 1, but cover only the items relating to the particular system under consideration. For example, in Table 1 under Poor Acceleration, the ignition system is listed as a probable cause of the trouble. In the Ignition System Trouble Shooting Chart under Poor Acceleration, all the ignition system items that affect acceleration are listed. These items should all be checked before proceeding to the next item listed in Table 1.

100% SATISFACTION GUARANTEED

BUY IT NOW!

Click Here To Order

TABLE 1—General Engine Trouble Shooting

<p>ENGINE WILL NOT CRANK</p>	<p>The cause of this trouble is usually in the starting system (Group 9—Part 2). If the starting system is not at fault, check for a hydrostatic lock or a seized engine. Remove the spark plugs, then attempt to crank the</p>	<p>engine with the starter. If the engine cranks, it indicates that water is leaking into the cylinders. Remove the cylinder head(s) and inspect the gasket(s) and/or head(s) for cracks. Also examine the cylinder block for cracks.</p>
<p>ENGINE CRANKS NORMALLY, BUT WILL NOT START</p>	<p>Check the fuel supply. If there is sufficient fuel in the tank, the cause of the trouble probably lies in either the ignition or the fuel system. To isolate the cause: Remove the ignition wire from a spark plug, and insert a piece of proper sized metal rod in the insulator so that it protrudes from the insulator. With the ignition on and the starter cranking the engine, hold the end of the rod approximately $\frac{3}{16}$</p>	<p>inch from the cylinder block. If there is no spark or a weak spark, the cause of the trouble is in the ignition system (Group 2—Part 1). If the spark is good, check the spark plugs (Group 2—Part 1). If the spark plugs are not at fault, check the fuel system (Group 2—Part 2). If the fuel system is not at fault, check the valve timing (Group 1—Part 2, 3, or 4).</p>
<p>ENGINE STARTS, BUT FAILS TO KEEP RUNNING</p>	<p>If the engine starts and runs for a few seconds, then stops, check the: Fuel system (Group 2—Part 2). Ignition system (Group 2—Part 1).</p>	<p>No oil pressure (on trucks with an electric fuel pump the safety switch would automatically shut off the electric fuel pump).</p>
<p>ENGINE RUNS, BUT MISSES</p>	<p>First, determine if the miss is steady or erratic and at what speed the miss occurs by operating the engine at various speeds under load. MISSES STEADILY AT ALL SPEEDS Isolate the miss by operating the engine with one cylinder not firing. This is done by operating the engine with the ignition wire removed from one spark plug at a time, until all cylinders have been checked. Ground the spark plug wire removed. If the engine speed changes when a particular cylinder is shorted out, that cylinder was delivering power before being shorted out. If no change in the engine operation is evident, the miss was caused by that cylinder not delivering power before being shorted out, check the: Ignition system Engine compression</p>	<p>MISSES ERRATICALLY AT ALL SPEEDS Check the: Exhaust gas control valve (page 1-8). Ignition system (Group 2—Part 1). Fuel system (Group 2—Part 2). Engine compression to determine which mechanical component of the engine is at fault (page 1-7). Exhaust system for excessive back pressure. Cooling system for internal leaks and/or for a condition that prevents the engine from reaching normal operating temperature (Group 2—Part 3).</p>

100% SATISFACTION GUARANTEED

BUY IT NOW!

Click Here To Order

PayPal American Express Cards DISCOVER NOVUS MasterCard VISA

TABLE 1—General Engine Trouble Shooting (cont'd)

<p>ENGINE RUNS, BUT MISSES (cont'd)</p>	<p>MISSES AT IDLE ONLY</p> <p>Check the:</p> <ul style="list-style-type: none"> Fuel system (Group 2—Part 2). Ignition system (Group 2—Part 1). Vacuum booster pump, lines, and fittings for leaks (223 Six only). Valve lash (Group 1—Part 2, 3, or 4). Engine compression for low compression (page 1-7). 	<p>MISSES AT HIGH SPEED ONLY</p> <p>Check the:</p> <ul style="list-style-type: none"> Ignition system (Group 2—Part 1). Fuel System (Group 2—Part 2). Cooling system for overheating or internal leakage (Group 2—Part 3).
<p>ROUGH ENGINE IDLE</p>	<p>Check the:</p> <ul style="list-style-type: none"> Fuel system (Group 2—Part 2). Ignition system (Group 2—Part 1). Exhaust gas control valve (page 1-8). Valve lash (Group 1—Part 2, 3, or 4). Vacuum booster pump, lines, 	<ul style="list-style-type: none"> and fittings for leaks (223 Six only). Loose engine mounts (Group 1—Part 2, 3, or 4). Improper cylinder head bolt torque (Group 1—Part 2, 3, or 4). Leaking power brake vacuum booster (Group 8—Part 2).
<p>POOR ACCELERATION</p>	<p>Check the:</p> <ul style="list-style-type: none"> Ignition system (Group 2—Part 1). Fuel system (Group 2—Part 2). Exhaust gas control valve (page 1-8). Valve lash (Group 2—Part 2, 3, or 4). 	<ul style="list-style-type: none"> Brakes for proper adjustment (Group 8). Clutch slippage (Conventional Drive and Overdrive Transmission) (Group 3). Automatic transmission for proper adjustment.
<p>ENGINE DOES NOT DEVELOP FULL POWER, OR HAS POOR HIGH SPEED PERFORMANCE</p>	<p>Determine if the trouble exists when the engine is cold, at normal operating temperature, or at all engine temperatures.</p> <p>ENGINE COLD</p> <p>Check the:</p> <ul style="list-style-type: none"> Exhaust gas control valve (page 1-8). Fuel system (Group 2—Part 2). Cooling system if the engine reaches operating temperature slowly (Group 2—Part 3). <p>ENGINE AT NORMAL OPERATING TEMPERATURE</p> <p>Check the:</p> <ul style="list-style-type: none"> Exhaust gas control valve (page 1-8). Fuel system (Group 2—Part 2). 	<p>ALL ENGINE TEMPERATURES</p> <p>Check the:</p> <ul style="list-style-type: none"> Engine compression (page 1-7). Ignition system (Group 2—Part 1). Fuel system (Group 2—Part 2). Governor (Group 2—Part 3). Valve lash (Group 1—Part 2, 3, or 4). Camshaft lobe lift (page 1-13). Valve timing (Group 1—Part 2, 3, or 4). Cooling system if the engine overheats (Group 2—Part 3). Exhaust system for excessive back pressure. Torque converter (Automatic Transmission). Brake adjustment (Group 8). Tire pressure (Group 6—Part 3).



BUY IT NOW!

Click Here To Order



TABLE 1—General Engine Trouble Shooting (cont'd)

<p>EXCESSIVE FUEL CONSUMPTION</p>	<p>Determine the actual fuel consumption with test equipment installed in the truck.</p> <p>If the test indicates that the fuel consumption is not excessive, demonstrate to the owner how improper driving habits will affect fuel consumption.</p> <p>If the test indicates that the fuel consumption is excessive, make the preliminary checks listed below before proceeding to the fuel and ignition systems.</p> <p>PRELIMINARY CHECKS</p> <p>Tires (Group 6—Part 3). Wheel alignment (Group 6—Part 3). Brakes (Group 8).</p>	<p>Exhaust gas control valve (Group 1—Part 2, 3, or 4). Odometer calibration (Group 10—Part 1). Ignition timing (Group 2—Part 1). Valve lash (Group 1—Part 2, 3, or 4).</p> <p>FUEL SYSTEM (Group 2—Part 2).</p> <p>IGNITION SYSTEM (Group 2—Part 1).</p> <p>ENGINE COMPRESSION (Page 1-7).</p> <p>COOLING SYSTEM (Group 2—Part 3).</p> <p>TORQUE CONVERTER</p>
<p>ENGINE OVERHEATS</p>	<p>Temperature sending unit (Group 10—Part 1). Temperature gauge (Group 10—Part 1). Exhaust gas control valve (page 1-8). Cylinder head bolt torque (Group 1—Part 2, 3, or 4).</p>	<p>Cooling system (Group 2—Part 4). Ignition timing (Group 2—Part 1). Valves (page 1-10). Exhaust system. Brakes (Group 8).</p>
<p>ENGINE FAILS TO REACH NORMAL OPERATING TEMPERATURE</p>	<p>Temperature sending unit (Group 10—Part 1). Temperature gauge (Group 10—Part 1).</p>	<p>Engine thermostat(s) (Group 2—Part 4).</p>

2 TUNE-UP

tune-up is a systematic procedure for testing various engine components.

100% SATISFACTION GUARANTEED

BUY IT NOW!

Click Here To Order



The Tune-Up Schedule (Table 2) is applicable for either a minor or major tune-up. A minor tune-up is recommended each 8000 miles and a major tune-up is recommended each 24,000 miles. The reference after

each operation refers to that part of the manual which describes, in detail, the procedure to be followed. Perform the operations in the sequence listed.

TABLE 2—Tune-Up Schedule

Operation	Perform on		Recommended Procedure
	Minor	Major	
SPARK PLUGS Clean, adjust, and test.	X	X	Group 2 Part 1
ENGINE COMPRESSION Take compression reading of each cylinder.		X	Page 1-7
INTAKE MANIFOLD Check and adjust bolt torque.		X	Group 1 Part 2, 3, or 4
DRIVE BELTS Check and adjust the tension of all drive belts.	X	X	Group 2 Part 4
BATTERY Clean battery cables and terminals.		X	Group 9 Part 1
Tighten cable clamps.		X	
Grease battery terminals.		X	
Check battery state of charge.	X	X	
ELECTRICAL Oil generator rear bearing through cup (223 Six).		X	Group 9 Part 1
Check generator output.		X	
Check starter motor current draw.		X	
Check coil output.		X	Group 2 Part 1
Perform a primary circuit resistance test.		X	
Perform a secondary circuit continuity test.		X	
DISTRIBUTOR Check the condition of the breaker points.	X		Group 2 Part 1
Replace the breaker points and the condenser.		X	
Check and adjust the breaker arm spring tension.		X	
Lubricate the distributor cam. Oil the lubricating wick (Centrifugal Advance and Dual Advance Distributors). Lubricate the distributor			

Operation	Perform on		Recommended Procedure
	Minor	Major	
DISTRIBUTOR (Cont'd) Check and adjust centrifugal advance (Centrifugal Advance and Dual Advance Distributors).		X	Group 2 Part 1
Check and adjust vacuum advance (Loadomatic and Dual Advance Distributors).		X	
Clean distributor cap and rotor.	X	X	
FUEL SYSTEM Clean fuel pump filter bowl.	X	X	Group 2 Part 2
Replace fuel pump filter bowl strainer.		X	
Check fuel pump pressure and capacity.		X	
Drain fuel system filter.	X		
Replace fuel system filter element.		X	
Clean carburetor fuel bowl(s) and adjust float setting.		X	
ADJUSTMENTS Check and adjust ignition timing.	X	X	Group 2 Part 1
Check and adjust engine idle speed.	X	X	Group 2 Part 2
Adjust idle fuel mixture.	X	X	
Check and adjust valve lash.		X	Group 1 Part 2, 3, or 4
Check and adjust governor speed.	X	X	Group 2 Part 3
VACUUM Check manifold vacuum.	X	X	Page 1-7
EXHAUST Free the exhaust gas control valve.	X	X	Group 1 Part 1
COOLING SYSTEM Inspect the radiator, hoses, and engine for water leaks.		X	Group 2 Part 4
Add rust inhibitor to radiator.		X	



MANIFOLD VACUUM TEST

A manifold vacuum test aids in determining the condition of an engine and also in helping to locate the cause of poor engine performance. To test manifold vacuum:

1. Operate the engine for a minimum of ½-hour at 1200 rpm.
2. Install an accurate, sensitive vacuum gauge on the manifold vacuum line or on the fitting in the intake manifold.
3. Operate the engine at recommended idle rpm.
4. Check the vacuum reading on the gauge.

TEST CONCLUSIONS

Manifold vacuum is affected by carburetor adjustment, valve timing, the condition of the valves, cylinder compression, and leakage of the intake manifold, carburetor, or cylinder head gaskets.

Because abnormal gauge readings may indicate that more than one of the above factors is at fault, exercise caution in analyzing an abnormal reading. For example, if the vacuum is low, the correction of one item may increase the vacuum enough to indicate that the trouble has been corrected. It is important, therefore, that each cause of an abnormal reading be investigated and further tests conducted where necessary in order to arrive at the correct diagnosis of the trouble.

Table 3 lists various types of readings and their possible causes. This table is merely a guide, however, and not a firm standard.

Allowance should be made for the effect of altitude on the gauge reading. The engine vacuum will decrease with an increase in altitude.

ENGINE COMPRESSION TEST

1. Be sure the battery is good. Operate the engine for a minimum of ½ hour at 1200 rpm. Turn the ignition switch off, then remove all the spark plugs.

2. Set the throttle plates (primary throttle plates only on the 4-barrel carburetor) and choke plate in the wide open position.

TABLE 3—Manifold Vacuum Gauge Readings

Gauge Reading (Inches Hg.)	Engine Condition
16-17 (401 SD V-8) 17-18 (447, 534 SD V-8) 18-19 (223 Six and 302, 332 HD V-8) 19-20 (272, 292 MD and HD V-8)	Normal.
Low and steady.	Loss of power in all cylinders caused possibly by late ignition or valve timing, or loss of compression due to leakage around the piston rings.
Very low.	Manifold, carburetor, or cylinder head gasket leak.
Needle fluctuates steadily as speed increases.	A partial or complete loss of power in one or more cylinders caused by: a leaking valve; cylinder head or intake manifold gasket leak; a defect in the ignition system; or a weak valve spring.
Gradual drop in reading at engine idle.	Excessive back pressure in the exhaust system.
Intermittent fluctuation.	An occasional loss of power possibly caused by a defect in the ignition system or a sticking valve.
Slow fluctuation or drifting of the needle.	Improper idle mixture adjustment, carburetor or intake manifold gasket leak, or possibly late valve timing.

3. Install a compression gauge in No. 1 cylinder.

4. Crank the engine until the gauge registers a maximum reading and record the reading. Note the number of compression strokes required to obtain the maximum reading.

5. Repeat the test on each cylinder, cranking the engine the same number of strokes for each cylinder as was required to obtain a maximum reading on No. 1 cylinder.

TEST CONCLUSIONS

A variation of ± 20 pounds from specified pressure is satisfactory. However, the compression of all cylinders should be uniform within 10 pounds.

A reading of more than 20 pounds above normal indicates excessive deposits in the cylinder.

A reading of more than 20 pounds below normal indicates leakage at the cylinder head gasket, piston rings, or valves.

A low even compression in two adjacent cylinders indicates a cylinder head gasket leak. This should be checked before condemning the rings or valves.

To determine whether the rings or the valves are at fault, squirt the equivalent of a tablespoon of heavy oil into the combustion chamber, then crank the engine to distribute the oil and repeat the compression test. The oil will temporarily seal leakage past the rings. If approximately the same reading is obtained, the rings are satisfactory, but the valves are leaking. If the compression has increased 10 pounds or more over the original reading, there is leakage past the rings.

During a compression test, if the pressure fails to climb steadily and remains the same during the first two successive strokes, but climbs higher on the succeeding strokes, or fails to climb during the entire test, it indicates a sticking valve.

**MANIFOLDS, CYLINDER HEADS, AND VALVES****BUY IT NOW!****Click Here To Order**

On the intake manifolds for all engines except the SD V-8 engines, scrape all carbon deposits from the center exhaust passage below the car-

buretor heat riser of the intake manifold. This carbon acts as an insulator restricting the heating action of the hot exhaust gases.

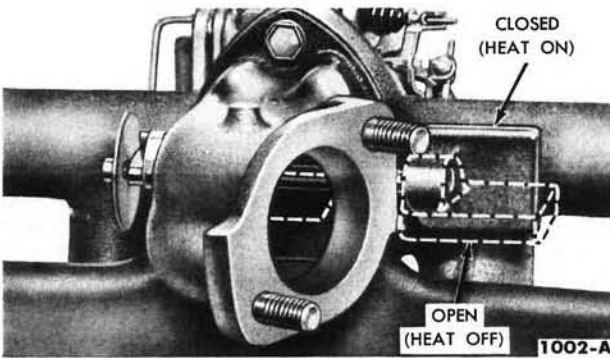
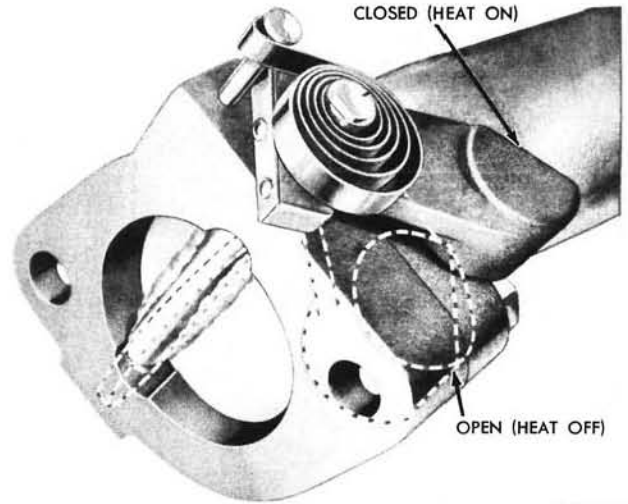
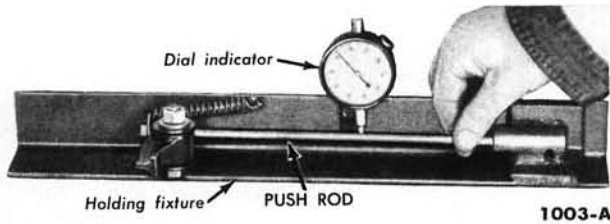

FIG. 1—Exhaust Gas Control Valve—223 Six



1001-A

FIG. 2—Exhaust Gas Control Valve—272, 292 MD V-8



1003-A

FIG. 3—Push Rod Runout—Typical

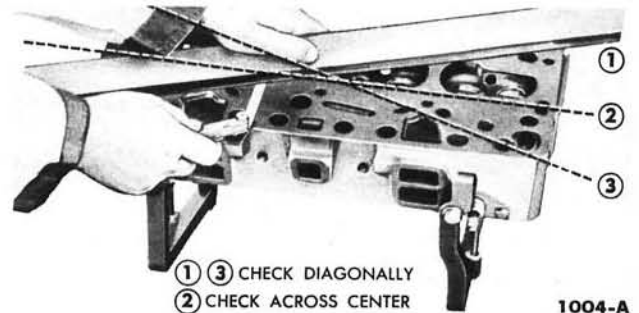

1004-A

FIG. 4—Cylinder Head Flatness—Typical

Inspect the manifolds for cracks, leaks, or other defects that would make them unfit for further service. Replace all studs that are stripped or otherwise damaged. **Remove all filings and foreign matter that may have entered the manifolds as a result of repairs.**

EXHAUST GAS CONTROL VALVE (223 SIX AND 272, 292 MD V-8)

Check the thermostatic spring to make sure it is hooked on the stop pin. The spring stop is at the top of the valve housing when the valve is properly installed. The action of the valve is illustrated in Fig. 1 or 2.

Check to make sure the spring holds the valve closed when the engine is cold. Actuate the counterweight by hand to make sure it moves freely through approximately 90° of rotation without binding.

The valve is closed when the engine is at normal operating temperature and running at idle speed. However, a properly operating valve will close at very light finger pressure

temperature and is operated at high rpm. Free stuck valves with a penetrating oil and graphite mixture.

VALVE ROCKER ARM SHAFT ASSEMBLY

Clean all the parts thoroughly. Make sure that all oil passages are open.

Check the clearance between each rocker arm and the shaft by checking the I.D. of the rocker arm bore and the O.D. of the shaft. If the clearance between any rocker arm and the shaft exceeds the wear limit, replace the shaft and/or the rocker arm. Inspect the shaft and the rocker arm bore for nicks, scratches, scores, or scuffs. Dress up minor surface defects with a hone.

Inspect the pad at the valve end of the rocker arms for a grooved radius. If the pad is grooved, replace the rocker arm. **Do not attempt to true the surface by grinding.**

Check the rocker arm adjusting screws and the push rod end of the rocker arms for stripped or broken threads, and the ball end of the adjusting screw for nicks, scratches, or excessive wear.

Check for broken locating springs. Inspect the oil tubes (except SD V-8 engines) for cracks or sharp bends.

PUSH RODS

Check the ball end and the socket end of the push rods for nicks, grooves, roughness, or excessive wear.

The push rods can be visually checked for straightness while they are installed in the engine by rotating them with the valve closed. They also can be checked between ball and cup centers with a dial indicator (Fig. 3). If the runout exceeds the maximum limit at any point, discard the rod. **Do not attempt to straighten push rods.**

100% SATISFACTION GUARANTEED

BUY IT NOW!

Click Here To Order

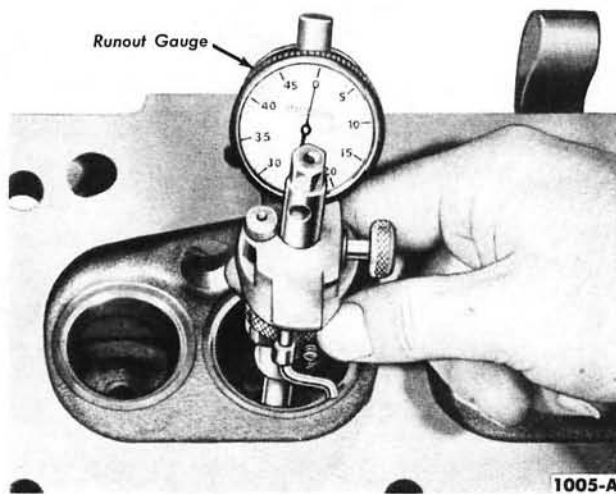

FIG. 5—Valve Seat Runout—Typical

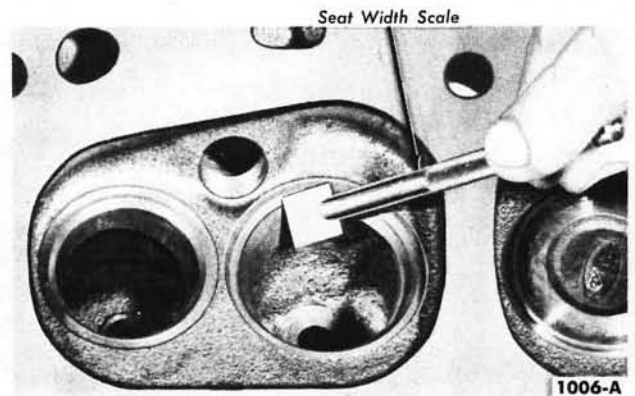

FIG. 6—Valve Seat Width—Typical

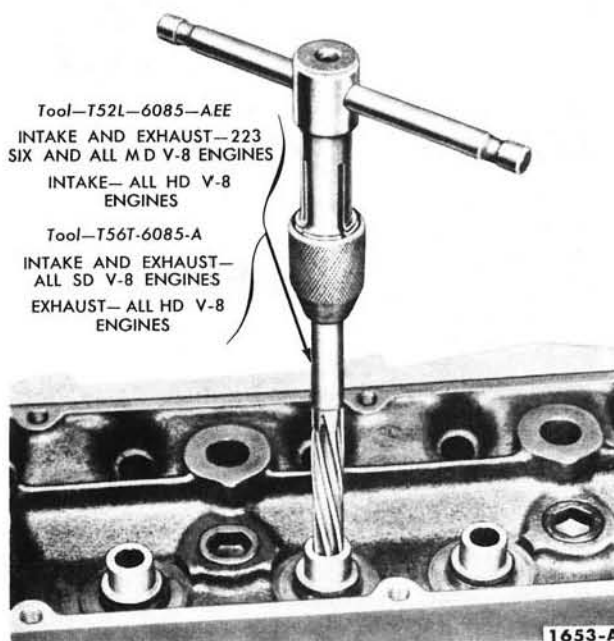

FIG. 7—Reaming Valve Guides—Typical

CYLINDER HEADS

To protect the machined surfaces of the cylinder head, use holding fixtures while the head is off the engine.

CLEANING AND INSPECTION

With the valves installed to protect valve seats, remove carbon de-

the valve guide bores with a valve guide cleaning tool. Use cleaning solvent to remove old gasket sealer, dirt, and grease.

Check the head for cracks, and the gasket surface for burrs and nicks. Replace the head if it is cracked. **Do not plane or grind more than 0.010 inch from the cylinder head gasket surface.** Remove all burrs or scratches with an oil stone.

Check the valve seat insert for signs of excessive wear, cracks, or

looseness (intake and exhaust 302 and 332 HD V-8 and all SD V-8 engines, exhaust only 272 and 292 HD V-8 engines).

Cylinder Head Flatness. Check the flatness of the cylinder head gasket surface (Fig. 4). Specifications for flatness are 0.006 inch maximum over all, or 0.003 inch in any 6 inches.

Valve Seat Runout. Check the valve seat runout with an accurate gauge (Fig. 5). Follow the instructions of the gauge manufacturer. The total runout should not exceed the wear limit.

Valve Seat Width. Measure the valve seat width (Fig. 6). It should be within specified limits.

REAMING VALVE GUIDES

If it becomes necessary to ream a valve guide (Fig. 7) to install a valve with an oversize stem, a reaming kit is available which contains the following reamer and pilot combinations; a 0.003-inch O.S. reamer with a standard diameter pilot, a 0.015-inch O.S. reamer with a 0.003-inch O.S. pilot, and a 0.030-inch reamer with a 0.015-inch O.S. pilot.

When going from a standard size valve to an oversize valve, always use the reamers in sequence. **Always reface the valve seat after the valve guide has been reamed.**

REFACING VALVE SEATS

Refacing of the valve seats should be closely coordinated with the refacing of the valve face so the finished seat will match the valve face and be centered. This is important so that the valve and seat will have a good compression and vacuum tight fit. Be sure that the refacer grinding wheels are properly dressed.

100% SATISFACTION GUARANTEED

BUY IT NOW!

Click Here To Order

PayPal American Express Cards DISCOVER NOVUS MasterCard VISA

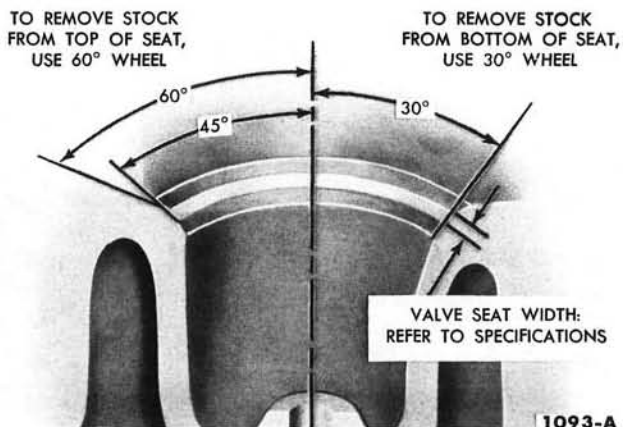

FIG. 8—Valve Seat Refacing—Typical

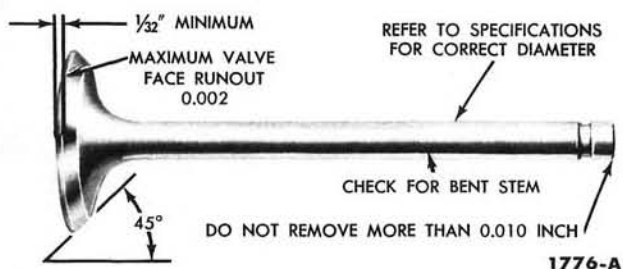

FIG. 10—Critical Valve Tolerances—Typical

Grind the valve seat to a true 45° angle (Fig. 8). Remove only enough stock to clean up pits, grooves, or to correct the valve seat runout. After the seat is ground, measure the seat width (Fig. 6). Narrow the seat, if necessary to bring it within limits.

If the valve seat width exceeds the maximum limit, remove enough stock from the top edge and/or bottom edge of the seat to reduce the width to specifications (Fig. 8). Use a 30° angle grinding wheel to remove stock from the bottom of the seat (raise the seat). Use a 60° angle wheel to remove stock from the top of the seat (lower the seat).

The finished valve seat should contact the approximate center of the valve face. To determine where the valve seat contacts the face, coat the seat with Prussian blue, then set the valve in place. Rotate the valve with light pressure. If the blue is transferred to the center of the valve face, the contact is satisfactory. If the blue is transferred to the top edge of the

valve with a medium grade lapping compound. Remove all the compound from the valve and seat after the lapping operation.

VALVE SEAT INSERT REPLACEMENT—HD AND SD V-8 ENGINES

The exhaust valve seats of the 272 and 292 HD V-8 are the insert-type and the intake and exhaust valve seats of the 302 and 332 HD V-8 and all SD V-8 engines are the insert type.

To remove the valve seat insert, invert the head and position a drift in the valve port, then drive the insert out.

Counterbore the insert recess to specifications (Fig. 9). Cut slightly below the old counterbore depth to clean up this face (approximately 0.001-0.002 inch). Clean out chips and oil from the recess.

Chill the oversize insert and the installation tool in dry ice for 1/2

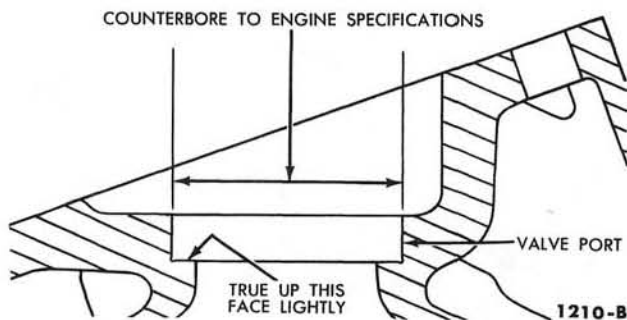

FIG. 9—Counterbore For Oversize Insert—HD and SD V-8 Engines

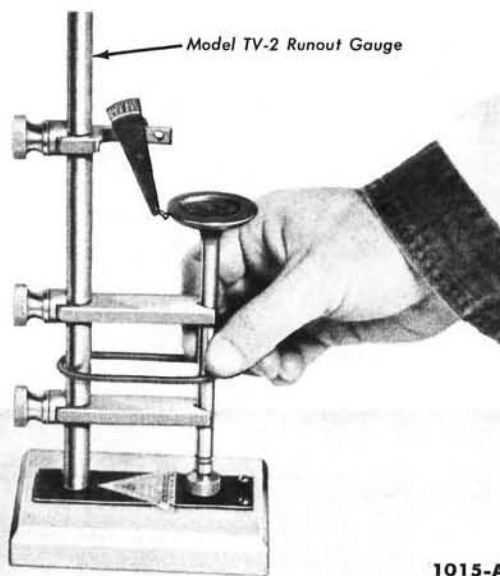

FIG. 11—Valve Face Runout—Typical

hour. The insert must be installed immediately upon removal from the dry ice. Protect the hands when handling the chilled insert and tool. Position the insert on the tool with the small radius on the outer edge facing outward. Pilot the driving tool in the valve guide, then drive the insert into the counterbore until it is fully seated. Do not peen the area around the insert. Reface the new insert.

VALVES

CLEANING AND INSPECTION

Remove all carbon and varnish from the valve with a fine wire brush or buffing wheel. The critical inspection points and tolerances of the valve are illustrated in Fig. 10.

Inspect the valve head and the edge of the valve face for pits, grooves, scores, or other defects. Inspect the stem for a bent condition

100% SATISFACTION GUARANTEED

BUY IT NOW!

Click Here To Order

PayPal American Express Discover Novus MasterCard VISA

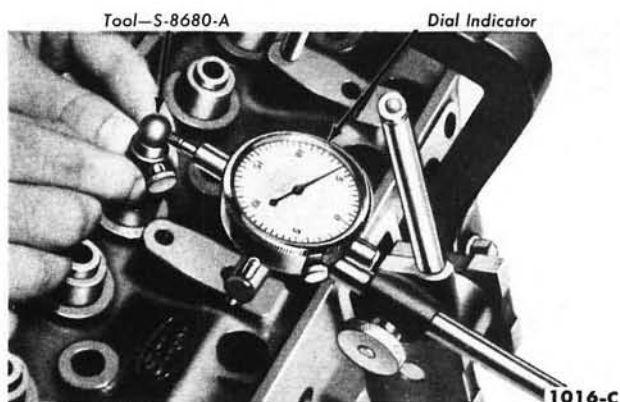

FIG. 12—Valve Stem Clearance—Typical

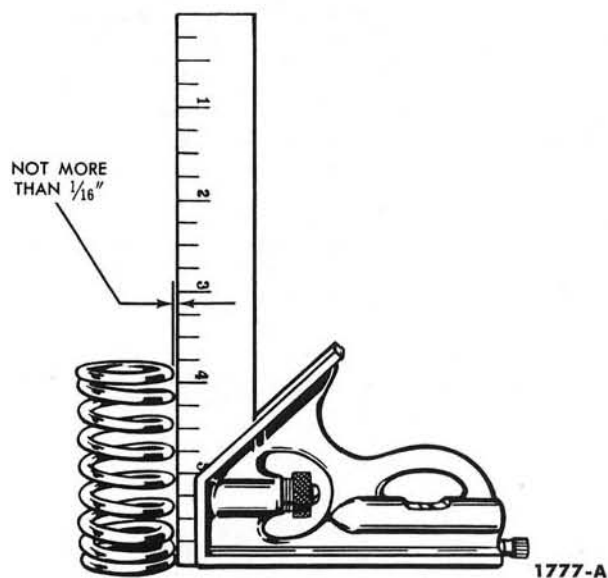

FIG. 14—Valve Spring Squareness

and the end of the stem for grooves or scores. Check the valve head for signs of burning or erosion, warpage, and cracking. Defects, such as minor pits, grooves, etc., may be removed. Discard valves that are severely damaged. **Do not discard sodium cooled valves (exhaust valves of all HD and SD V-8 engines) with other scrap metal in scrap bins. If a sodium cooled valve is accidentally broken and the sodium exposed, it will react violently upon contact with water resulting in fire and explosion due to chemical action. Therefore, these**

jected to dredging.

Inspect the valve springs, valve spring retainers, locks, and sleeves for defects. Discard any defective parts.

Valve Face Runout. Check the valve face runout (Fig. 11). It should not exceed the wear limit.

Valve Stem Clearance. Check the valve stem to valve guide clearance of each valve in its respective valve guide with the tool shown in Fig. 12 or its equivalent.

Install the tool on the valve stem until fully seated and tighten the set screw, then permit the valve to drop away from its seat until the tool contacts the upper surface of the valve guide. Position a dial indicator with a flat tip against the center portion of

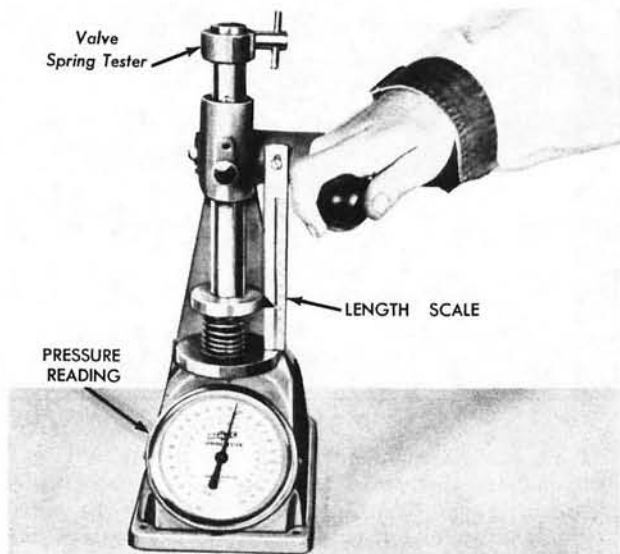

FIG. 13—Valve Spring Pressure

the spherical section of the tool at approximately 90° to the valve stem. Move the tool back and forth on a plane that parallels normal rocker arm action and take the indicator reading without lifting the tool from the valve guide upper surface. Divide the indicator reading by 2 (division factor of the tool) to obtain the actual stem clearance. If the clearance exceeds the wear limit, try a new valve.

Valve Spring Pressure. Check the valve spring for proper pressure (Fig. 13). Weak valve springs cause poor performance; therefore, if the pressure of any spring exceeds the wear limit, replace the spring.

Valve Spring Squareness. Check each spring for squareness using a steel square and a surface plate (Fig. 14). Stand the spring and square on end on the surface plate. Slide the spring up to the square. Revolve the spring slowly and observe the space between the top coil of the spring and the square. If the spring is out of square more than $\frac{1}{16}$ inch, replace it.

REFACING VALVES

The valve refacing operation should be closely coordinated with the valve seat refacing operation so that the finished angle of the valve face will match the valve seat. This is important so that the valve and seat will have a good compression tight fit. Be sure that the refacer grinding wheels are properly dressed.

100% SATISFACTION GUARANTEED

BUY IT NOW!

Click Here To Order

PayPal American Express DISCOVER NOVUS MasterCard VISA

TABLE 4—Valve Timing Specifications

Engine	Intake Valve				Exhaust Valve			
	Opens		Closes		Opens		Closes	
	Crankshaft Degrees	Camshaft Lobe Lift	Crankshaft Degrees	Camshaft Lobe Lift	Crankshaft Degrees	Camshaft Lobe Lift	Crankshaft Degrees	Camshaft Lobe Lift
223 Six	17° B.T.C.	0.016	53° A.B.C.	0.019	61° B.B.C.	0.016	9° A.T.C.	0.019
272, 292 MD, HD V-8	18° B.T.C.	0.015	58° A.B.C.	0.015	66° B.B.C.	0.013	10° A.T.C.	0.016
302, 332 HD V-8	22° B.T.C.	0.017	62° A.B.C.	0.019	56° B.B.C.	0.017	20° A.T.C.	0.019
SD V-8	18° B.T.C.	0.0175	58° A.B.C.	0.0195	56° B.B.C.	0.0175	20° A.T.C.	0.0195

If the valve face runout is excessive and/or to remove pits and grooves, grind the valve to a true 45° angle. Remove only enough stock to correct the runout or to clean up the pits and grooves. If the edge of the valve head is less than 1/32 inch after refacing, replace the valve as the valve will run too hot in the engine.

Grind off all grooves or score marks from the end of the valve stem, then chamfer as necessary. Do not remove more than 0.010 inch from the stem.

After refacing the valves, it is good practice to lightly lap in the valves with a medium grade lapping compound to match the seats. Be sure to remove all of the compound from the valve and seat after the lapping operation.

SELECT FITTING VALVES

If the valve stem to the valve guide clearance exceeds the wear limit, it is recommended that the valve guide be reamed for the next oversized valve stem. Valves with oversize stem diam-

eters of 0.003, 0.015, and 0.030 inch are available for service. **Always reface the valve seat when the valve guide is reamed.**

VALVE TIMING

The valve timing should be checked when poor engine performance is noted and all other checks, such as carburetion, ignition timing, etc. fail to locate the cause of the trouble.

Before the valve timing is checked, check for a bent timing pointer. Bring the No. 1 piston to T.D.C. on the compression stroke and see if the timing pointer is aligned with the T.D.C. mark on the damper.

If the valve timing is not within specifications, check the timing chain, camshaft sprocket or gear, crankshaft sprocket or gear, camshaft, and crankshaft in the order of accessibility.

To check the valve timing with the engine installed in the truck, proceed as follows:

Install a quadrant on the crankshaft damper. Back off the No. 1 intake valve adjusting screw, then slide the rocker arm to one side and secure it in this position. Make sure the push rod is in the tappet socket, then install a dial indicator in such a manner as to have the actuating point of the indicator in the push rod socket and in the same plane as the push rod movement (Fig. 18). Turn the crankshaft damper slowly in the direction of rotation until the tappet is on the base circle of the camshaft lobe. At this point the push rod will be in its lowest position. Zero the dial indicator and continue turning the crankshaft slowly in the direction of rotation until the dial indicator registers the specified camshaft lobe lift (Table 4).

Compare the crankshaft degrees indicated on the quadrant with specifications (Table 4). After the valve opening is checked, continue to rotate the engine to check the valve closing.

4 TIMING CHAIN, TIMING GEARS, CAMSHAFT, AND BEARINGS

TIMING CHAIN—223 SIX AND 272, 292 MD AND HD V-8 CLEANING AND INSPECTION

Clean all parts in solvent and dry them with compressed air. Inspect the chain for broken links and the sprockets for cracks, worn or damaged teeth. It is recommended that all links be replaced if any

condition of the gear teeth. If the teeth are scored or the contact pattern on the teeth is uneven, replace the gear(s). It is good practice to replace both gears if either gear needs replacing.

BACKLASH

Check the backlash between the camshaft gear and the crankshaft gear with a dial indicator (Fig. 15). Hold the gear firmly against the block while making the check. Refer to the specifications for the backlash limits.

RUNOUT

Check the camshaft and crankshaft gear runout with a dial indicator (Fig. 16). If the gear runout is excessive, remove the gear and clean any burrs from the shaft, or replace the gear and/or gears.

CAMSHAFT AND BEARINGS

CLEANING AND INSPECTION

Clean the camshaft in solvent and wipe dry. Inspect the camshaft lobes for pitting, scoring, and signs of ab-

100% SATISFACTION GUARANTEED

BUY IT NOW!

Click Here To Order

PayPal American Express Discover MasterCard VISA

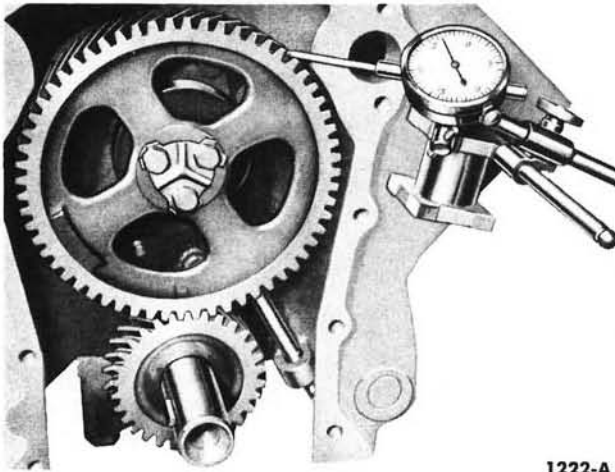

1222-A

FIG. 15—Camshaft Gear Backlash—Typical

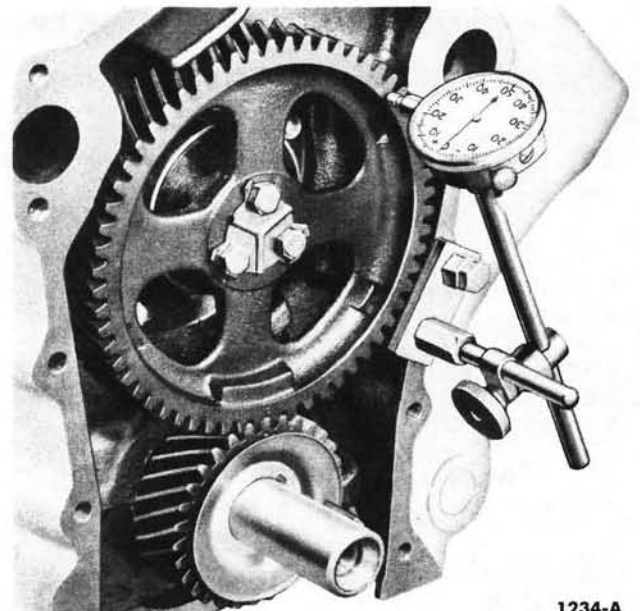

1234-A

FIG. 16—Camshaft Gear Runout—Typical

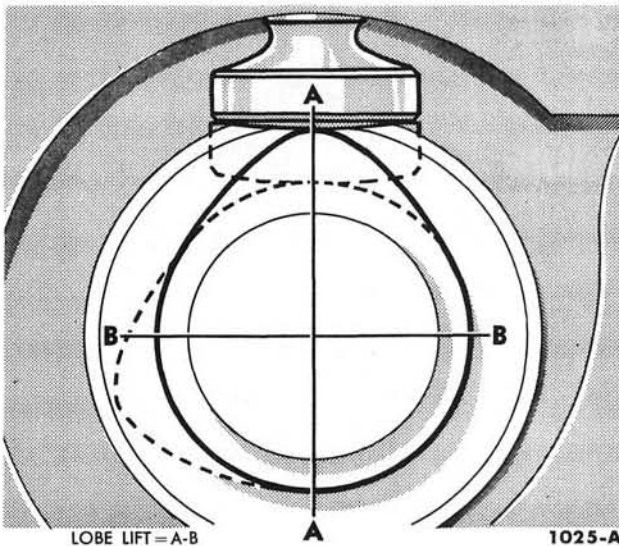

1025-A

FIG. 17—Camshaft Lobe Lift Measurement

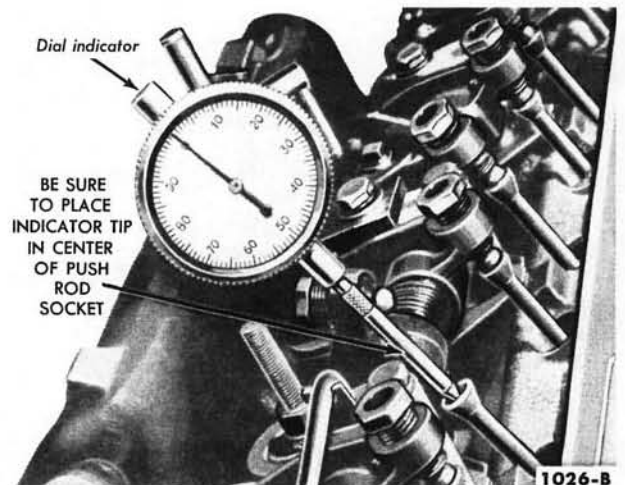

1026-B

FIG. 18—Camshaft Lobe Lift—Typical

normal wear. Lobe wear characteristics may result in pitting in the general area of the nose portion of the lobe. This pitting is not detrimental to the operation of the camshaft, therefore, the camshaft should not be replaced until the camshaft lobe lift loss has exceeded 0.005 inch. The lift of suspected worn lobes should be checked by measuring over the top of the lobe with a micrometer and sub-

of the bearings. If the clearance exceeds the wear limit, the camshaft journals should be ground for undersize bearings or the camshaft replaced, and/or the bearings should be replaced. Bearings are available pre-finished to size for standard and undersize journal diameters. Check the parts catalog for the undersizes available.

Check the distributor drive gear (and governor drive gear on SD V-8 engines) for broken or chipped teeth.

Remove light scuffs, scores, or nicks from the camshaft machined surfaces with a smooth oilstone.

CAMSHAFT LOBE LIFT (CAMSHAFT INSTALLED)

This procedure is similar to the procedure for checking valve timing. Loosen the valve rocker arm adjusting screw, then slide the rocker arm assembly to one side and secure it in this position. Make sure the push rod is in the tappet socket, then install a dial indicator in such a manner as to have the actuating point of the indicator in the push rod socket and in the same plane as the push rod movement (Fig. 18). Turn the crankshaft damper slowly in the direction of rotation until the tappet is on the

100% SATISFACTION GUARANTEED

BUY IT NOW!

Click Here To Order

PayPal, American Express, Discover, MasterCard, VISA

base circle of the camshaft lobe. At this point, the push rod will be in its lowest position. Set the dial indicator on zero, then continue to rotate the

damper slowly until the push rod is in the fully raised position. Compare the total lift recorded on the indicator with specifications. Continue to ro-

tate the damper until the indicator reads zero. This later step is a check on the accuracy of the original indicator reading.

5 FLYWHEEL, CRANKSHAFT, CONNECTING RODS, PISTON ASSEMBLIES, AND BEARINGS

CONVENTIONAL DRIVE FLYWHEEL

INSPECTION

Inspect the flywheel for cracks, heat check, or other defects that would make it unfit for further service. Machine the friction surface of the flywheel if it is scored or worn. If it is necessary to remove more than 0.045 inch of stock from the original thickness, replace the flywheel.

Inspect the ring gear for worn, chipped, or cracked teeth. If the teeth are damaged, replace the ring gear.

With the flywheel installed on the crankshaft, check the flywheel face runout.

FLYWHEEL FACE RUNOUT

Install a dial indicator so that the tip bears against the flywheel face (Fig. 19). Turn the flywheel, making sure that the crankshaft is full forward or rearward so that crankshaft end play will not be indicated as flywheel runout.

If the runout exceeds the maximum limit, remove the flywheel and check for burrs between the flywheel

and the face of the crankshaft mounting flange. If no burrs exist, check the runout of the crankshaft mounting flange. Replace the flywheel or machine the crankshaft flywheel face if the mounting flange runout is excessive.

AUTOMATIC DRIVE FLYWHEEL

The procedure for checking the flywheel on trucks with an automatic transmission is covered in Group 4.

CRANKSHAFT

Handle the crankshaft with care to avoid possible fractures or damage to the finished surfaces.

CLEANING AND INSPECTION

Clean the crankshaft with solvent, then blow out all oil passages with compressed air.

Inspect main and connecting rod journals for cracks, scratches, grooves, or scores. Dress minor imperfections with an oilstone. Reface severely marred journals.

Measure the diameter of each journal in at least four places to determine out-of-round, taper, or under-

size condition (Fig. 20).

If the journals exceed the wear limit, they should be refinished to size for the next undersize bearing.

REFINISHING JOURNALS

Refinish the journal to give the proper clearance with the next undersize bearing. If the journal will not "clean up" to give the proper clearance with the maximum undersize bearing available, replace the crankshaft.

Always reproduce the same journal shoulder radius that existed originally. Too small a radius will result in fatigue failure of the crankshaft. Too large a radius will result in bearing failure due to radius ride of the bearing.

After refinishing the journals, chamfer the oil hole, then polish the journal with a No. 320 grit polishing cloth and engine oil. Crocus cloth may also be used as a polishing agent.

CONNECTING RODS

The connecting rods and related parts should be carefully inspected and checked for conformance to specifications. Various forms of engine wear caused by these parts can be readily identified.

A shiny surface on the pin boss side of the piston usually indicates that a connecting rod is bent or the piston pin hole is not in proper rela-



1049-B

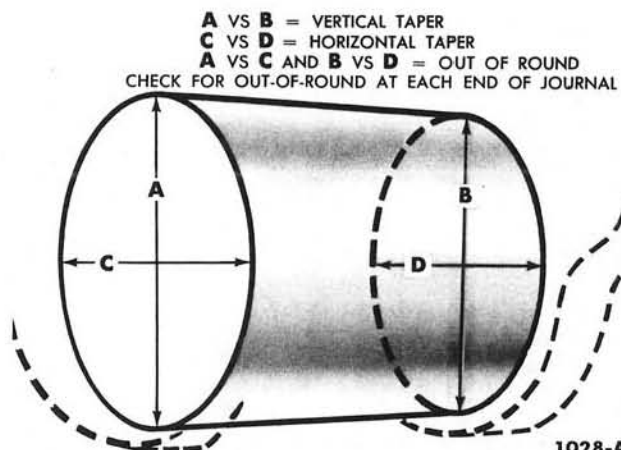

1028-A

FIG. 20—Crankshaft Journal Measurements

100% SATISFACTION GUARANTEED

BUY IT NOW!

Click Here To Order

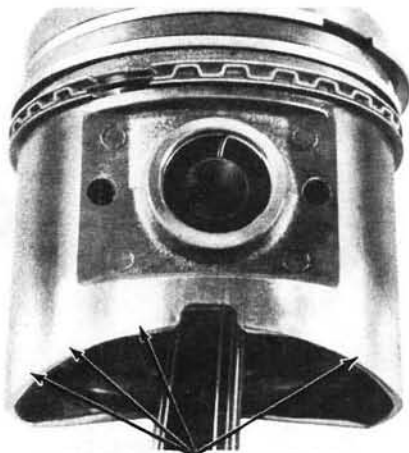

PISTON WEAR CAUSED BY BENT ROD OR MISALIGNED PISTON PIN HOLE

1045-A

FIG. 21—Wear Pattern on Piston Pin Boss Surface—Typical

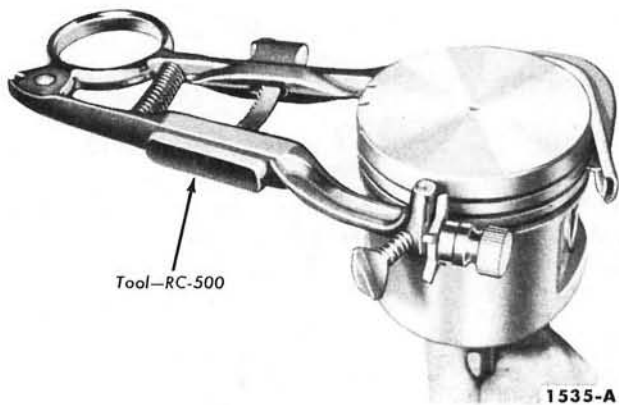

Tool—RC-500

1535-A

FIG. 23—Cleaning Ring Grooves—Typical

tion to the piston skirt and ring grooves (Fig. 21).

Abnormal connecting rod bearing wear can be caused by either a bent connecting rod, an improperly machined journal, or a tapered connecting rod bore (Fig. 22).

Twisted connecting rods will not create an easily identifiable wear pattern, but badly twisted rods will disturb the action of the entire piston, rings, and connecting rod assembly and may be the cause of excessive oil consumption.

CLEANING AND INSPECTION

Remove the bearings from the rod and cap (identify them if they are to be reused again). Clean the connecting

tures and the bearing bores for out-of-round and taper. If the bore exceeds the maximum limit and/or if the rod is fractured, it should be replaced.

Check the piston pin to connecting rod bushing clearance. Replace the connecting rod if the bushing is so worn that it cannot be reamed or honed for an oversize pin.

Replace defective connecting rod nuts and bolts.

After the connecting rods are assembled to the piston, check the rods for bend or twist on a suitable alignment fixture. Follow the instructions of the fixture manufacturer. If the bend and/or twist is excessive, the rod should be straightened or replaced.

PISTONS, PINS, AND RINGS

CLEANING AND INSPECTION

Remove carbon deposits from the

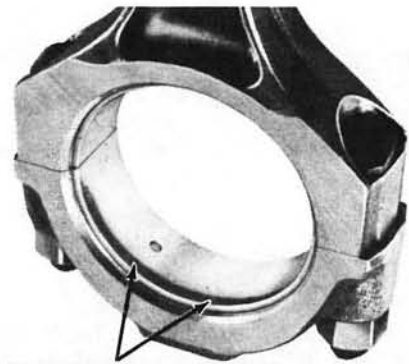

BEARING WEAR CAUSED BY BENT ROD OR IMPROPER GRINDING OF CRANKSHAFT JOURNAL

1046-A

FIG. 22—Wear Pattern on Connecting Rod Bearing—Typical

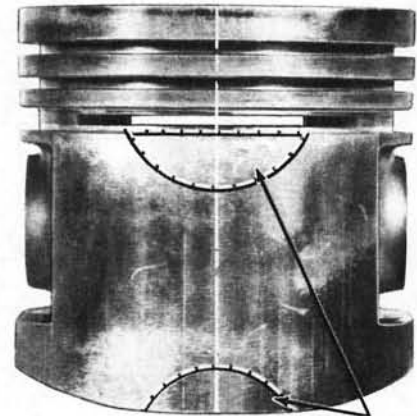

NORMAL WEAR AREAS 1041-A

FIG. 24—Piston Normal Wear Pattern—Typical

piston surfaces and from the underside of the piston head. Clean gum or varnish from the piston skirt, piston pins, and rings with solvent. **Do not use a caustic cleaning solution or a wire brush to clean pistons.** Clean the ring grooves with a ring groove cleaner (Fig. 23). Make sure the oil ring slots (or holes) are clean.

Carefully inspect the pistons for fractures at the ring lands, skirt, and pin bosses, and for scuffed, rough, or scored skirts. If the lower inner portion of the ring grooves have high steps, replace the piston. The step will interfere with ring operation and cause excessive ring side clearance.

Spongy, eroded areas near the edge of the piston top are usually caused by detonation, or pre-ignition. A shiny surface on the thrust surface of the piston, offset from the centerline between the piston pin holes, can be caused by a bent connecting rod. The normal wear pattern of a piston is shown in Fig. 24. Replace pistons

100% SATISFACTORY GUARANTEED

BUY IT NOW!

Click Here To Order

PayPal, American Express, Discover, MasterCard, VISA

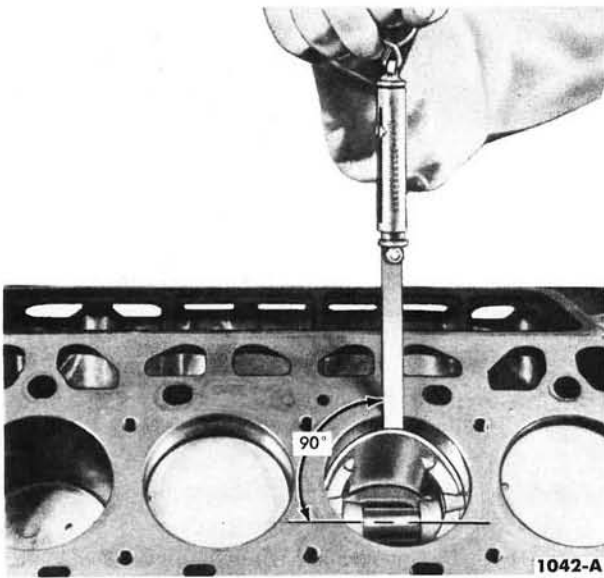

FIG. 25—Checking Piston Fit—Typical

that show signs of excessive wear, wavy ring lands, fractures, and/or damage from detonation or pre-ignition.

Check the piston to cylinder bore clearance with a tension scale and ribbon and the ring side clearance following the recommended procedures.

Replace piston pins showing signs of fracture or etching and/or wear. Check the piston pin fit in the piston and rod bushing.

Replace all rings that are scored, chipped, or cracked. Check the end gap and side clearance. It is good practice to always install new rings when overhauling the engine. **Rings should not be transferred from one piston to another regardless of mileage.**

FITTING PISTONS

Pistons are available for service in standard sizes and oversizes for use in cylinders that have been refinished. Pistons of 0.020, 0.030, 0.040, and 0.060-inch oversize are available for most engines. Check the parts catalog for sizes available.

The piston and cylinder block should be at room temperature (70°F) when piston fit is checked. After

by taking a bore check (Fig. 28), then select the proper size piston to provide the desired clearance.

Make sure the piston and cylinder bore are clean and dry. Attach a tension scale to the end of a feeler gauge ribbon that is free of dents or burrs. The feeler ribbon should be 1/2-inch wide and of the recommended thickness for the existing condition.

Position the ribbon in the bore so that it extends the entire length of the piston at 90° from the piston pin location. Invert the piston and install it in the bore so that the end of the piston is about 1 1/2 inches below the top of the cylinder block and the piston pin is parallel to the crankshaft axis.

Hold the piston and slowly pull the scale in a straight line with the ribbon, noting the pull required to remove the feeler ribbon (Fig. 25).

If the pull is within limits for the existing condition, the piston fit is satisfactory.

If the scale reading is greater than the maximum allowable pull, recheck calculations to be sure that the proper size piston has been selected, check for a damaged piston, then try a new piston.

If the scale reading is less than the minimum allowable pull, recheck calculations before trying another pis-

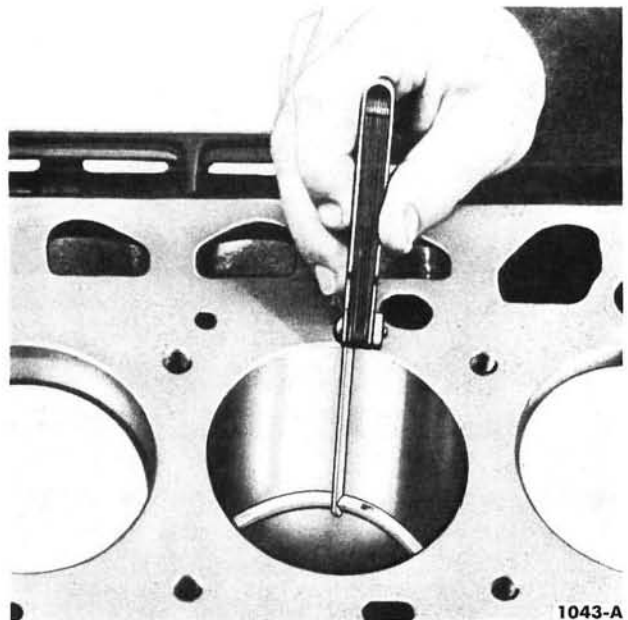

FIG. 26—Piston Ring Gap—Typical

ton. If none can be fitted, refinish the cylinder for the next size piston.

When a piston has been fitted, mark it for assembly in the cylinder to which it was fitted.

If the taper and out-of-round conditions of the cylinder bore are within limits, new piston rings will give satisfactory service provided the piston clearance in the cylinder bore is within limits. If the new rings are to be installed in a used cylinder that has not been refinished, remove the cylinder wall "glaze."

Select the proper ring set for the size piston to be used. The rings must be checked for proper gap in the cylinder bore and for the proper side clearance in the piston grooves. First, check each ring for proper gap as follows:

Position the ring in the cylinder bore in which it is going to be used. Push the ring down into the bore area where normal ring wear is not encountered. Use the head of a piston to position the ring in the bore so the ring is square with the cylinder wall. **Use caution to avoid damage to the ring or cylinder bore.** Measure the gap between the ends of the ring with a feeler gauge (Fig. 26).

If the ring gap is less than the recommended lower limit, try another ring set.



BUY IT NOW!

Click Here To Order



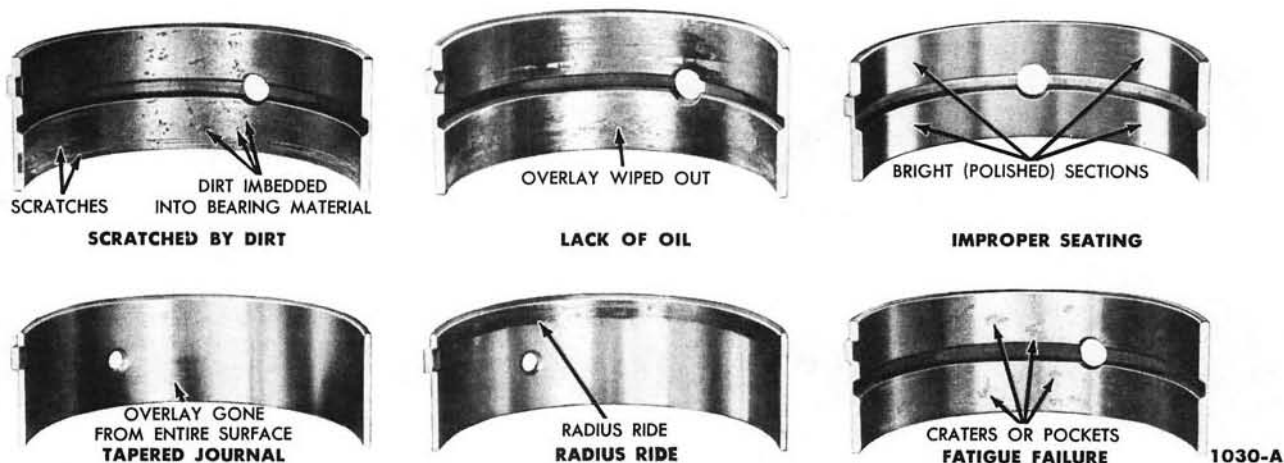

FIG. 27—Bearing Failures—Typical

FITTING PISTON PINS

The piston pin fit should be a light thumb press fit at normal temperature (70° F). Standard piston pins are color coded green. Pins of 0.001-inch oversize (color coded blue) and 0.002-inch oversize (color coded yellow) are available.

If the pin hole in the piston must be reamed, use an expansion-type, piloted reamer. Place the reamer in a vise and revolve the piston around the reamer. Set the reamer to the size of the pin bore, then expand the reamer slightly and trial ream the pin bore. Take a light cut. Use a pilot

sleeve of the nearest size to maintain alignment of the bores.

Check the hole size, using the new piston pin. If the bore is small, expand the reamer slightly and make another cut. Repeat the procedure until the proper fit is obtained. Check the fitted piston pin for fit in the respective rod bushing. If necessary, ream or hone the bushing to fit the pin.

Install the piston pin in the piston and rod. Install a new retainer at each end of the pin to hold it in place. When the retainers are installed, make sure they are properly

seated in the grooves provided in the piston pin bore.

MAIN AND CONNECTING ROD BEARINGS

Clean the bearing inserts and cap thoroughly. Inspect each bearing carefully. Bearings that have a scored, chipped, or worn surface should be replaced. Typical examples of bearing failures and their causes are shown in Fig. 27. Check the clearance of bearings that appear to be satisfactory with Plastigage. Fit new bearings following the recommended procedure (Group 1—Part 2, 3, or 4).

6 CYLINDER BLOCK

During the disassembly of the cylinder block for engine overhaul, closely inspect the wear pattern on all parts to help diagnose the cause of wear.

CLEANING AND INSPECTION

Thoroughly clean the block in solvent. Remove old gasket material from all machined surfaces. Remove all pipe plugs which seal oil passages, and clean out all the passages. Blow out all passages, bolt holes, etc.

reading. Use a tap to true-up threads and to remove any deposits.

After the block has been thoroughly cleaned, make a check for cracks. Minute cracks not visible to the naked eye may be detected by coating the suspected area with a mixture of 25% kerosene and 75% light motor oil. Wipe the part dry and immediately apply a coating of zinc oxide dissolved in wood alcohol. If cracks are present, the coating will become discolored at the defective area. Replace the block if it is cracked.

Check all machined gasket surfaces for burrs, nicks, scratches, and scores.

Remove minor imperfections with an oil stone. Check the flatness of the cylinder block gasket surface following the procedure and specifications recommended for the cylinder head (page 1-9).

Replace all expansion-type plugs that show evidence of leakage.

Inspect the cylinder walls for scoring, roughness, or other signs of wear. Check the cylinder bore for out-of-round and taper. Measure the bore with an accurate gauge following the instructions of the manufacturer. Measure the diameter of each cylinder bore at the top, middle, and bottom with the gauge placed at right

100% SATISFACTION GUARANTEED

BUY IT NOW!

Click Here To Order

PayPal American Express Cards DISCOVER NOW! MasterCard VISA

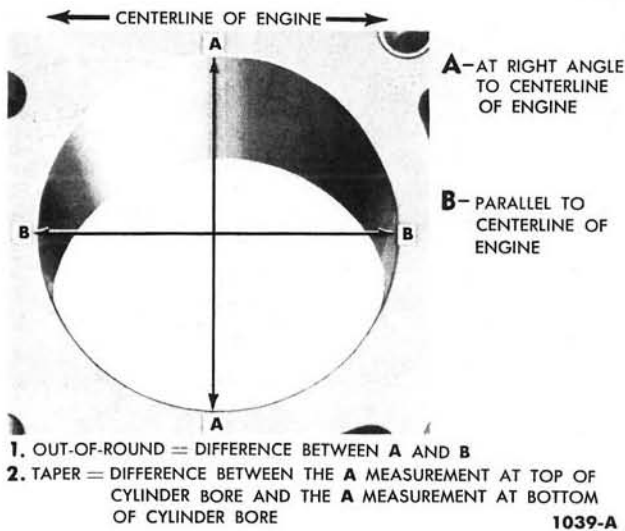

FIG. 28—Cylinder Bore Out-of-Round And Taper—Typical

angles and parallel to the centerline of the engine (Fig. 28).

Refinish cylinders that are deeply scored and/or when out-of-round and/or taper exceed the wear limits.

If the cylinder walls have minor surface imperfections, but the out-of-round and taper are within limits, it may be possible to remove the imperfections by honing the cylinder wall and installing new service piston rings providing the piston clearance is within limits. Use the finest grade of honing stone for this operation.

REFINISHING CYLINDER WALLS

Honing is recommended for refin-

ishing cylinder walls only when the walls have minor imperfections, such as light scuffs, scratches, etc. The grade of hone to be used is determined by the amount of metal to be removed. Follow the instructions of the hone manufacturer. If coarse stones are used to start the honing operation, leave enough material so that all hone marks can be removed with the finishing hone which is used to obtain the proper piston clearance.

Cylinder walls that are severely marred and/or worn beyond the specified limits should be refinished. Before any cylinder is refinished, all main bearing caps must be in place and tightened to the proper torque

so that the crankshaft bearing bores will not become distorted from the boring operation.

Refinish only the cylinder or cylinders that require it. **All pistons are the same weight, both standard and oversize; therefore, various sized pistons can be intermixed without upsetting engine balance.**

Refinish the cylinder with the most wear first to determine the maximum oversize. If the cylinder will not clean up when bored for the maximum oversize piston recommended, replace the block.

Refinish the cylinder to within approximately 0.0015 inch of the required oversize diameter. This will allow enough stock for the final step of honing so the correct surface finish and pattern are obtained. Use clean sharp hones of No. 220-280 grit for this operation.

For the proper use of the boring equipment, follow the instructions of the manufacturer. Only experienced personnel should be allowed to perform this work.

After the final operation in either of the two preceding refinishing methods and prior to checking the piston fit, thoroughly wash the cylinder walls with a suitable cleaner to remove all abrasive particles, then thoroughly dry. Check the piston fit. Mark the pistons to correspond to the cylinders in which they are to be installed. When the refinishing of all cylinders that require it has been completed and all pistons are fitted, thoroughly clean the entire block to remove all particles from the bearing bores, oil passages, head bolt holes, etc. Coat the cylinder walls with oil.

7 OIL PAN, OIL PUMP, AND OIL COOLER

OIL PAN

Scrape any dirt or metal particles from the inside of the pan. Scrape all old gasket material from the gasket surface. Wash the pan in a solvent and dry it thoroughly. Be sure all foreign matter is removed from the baffle plate.

OIL PUMP V-8 ENGINES

Wash all parts in a solvent and dry them thoroughly. Use a brush to clean the inside of the pump housing and the pressure relief valve chamber. Be sure all dirt and chips are removed.

Check the inside of the pump housing and the outer race and rotor for damage or excessive wear.

Check the mating surface of the pump cover for wear. If the covering surface is worn, scored, or pitted, replace the cover.

Measure the outer race to housing clearance (Fig. 29).

With the rotor assembly installed in the housing, place a straight edge over the rotor assembly and the housing. Measure the clearance between the straight edge and the rotor and outer race (Fig. 30).

The outer race, shaft and rotor are replaceable only as an assembly.

Check the drive shaft to housing bearing clearance by measuring the O.D. of the shaft and the I.D. of the housing bearing.

100% SATISFACTION GUARANTEED

BUY IT NOW!

Click Here To Order

PayPal American Express Discover MasterCard VISA

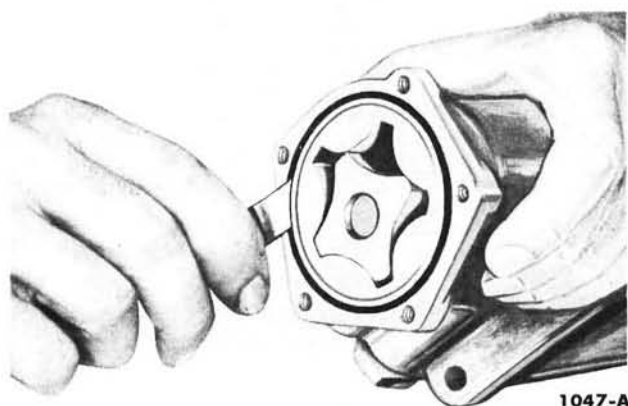

FIG. 29—Outer Race to Housing Clearance—V-8 Engines

Inspect the relief valve spring for a collapsed or worn condition.

Check the relief valve spring tension. If the spring tension is not within specifications and/or the spring is defective, replace the spring.

Check the relief valve piston for scores and free operation in the bore.

OIL PUMP—223 SIX ENGINE

Wash all parts in a solvent and dry them thoroughly. Use a brush to clean the inside of the pump housing and the pressure relief valve chamber. Be sure all dirt and chips are removed. Remove old gasket material from the pump body and cover.

Inspect the pump body and the gear teeth for damage or wear. Check the gear end clearance with a dial

indicator or Plastigage. The Plastigage method is as follows:

Position the gasket on the housing, then place Plastigage on the gears and install the cover. Remove the cover and check the Plastigage reading.

Check the gears for freedom of rotation. Check the compression of the oil pressure relief valve spring and check the clearance of the relief valve in the valve chamber.

OIL COOLER—SD V-8 ENGINES

Clean the oil cooler as soon as possible after removing it from the engine, or soak it in cleaning solvent until ready to clean. This will prevent hardening and drying of accumulated foreign material.

Immerse the oil cooler in a com-

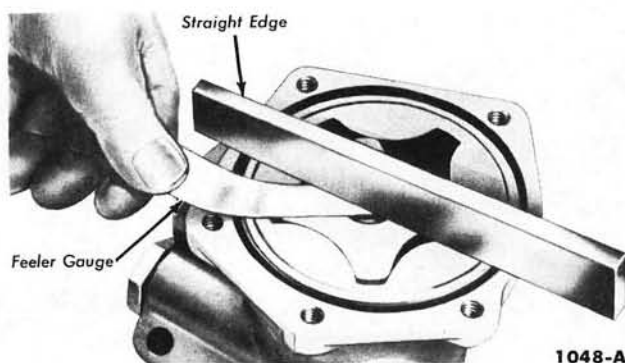

FIG. 30—Rotor End Play—V-8 Engines

mercial cleaning solvent and clean the outside of the plates with a stiff bristle brush.

Pressure circulate a standard commercial solvent (at a pressure of approximately 20 psi) through the oil passages of the cooler in the reverse direction of normal flow. Normal flow is from the bottom hole (inlet) to the top hole (outlet). If a circulating pump is not available, soak the cooler in solvent for a few minutes and force the solvent through the oil passages with a plunger or piston-type hand pump. If the oil passages are severely clogged, use an oakite or alkaline solution. After cleaning, pressure flush the cooler with clean hot water.

Thoroughly clean the passages in the cover and clean the relief valve assembly. Remove all old gasket sealer from the cover, oil cooler, and block.



BUY IT NOW!

Click Here To Order



PART 2
223 SIX ENGINE

Section	Page	Section	Page
1 Description	1-20	8 Main and Connecting Rod Bearing Replacement	1-39
2 Engine Removal and Installation	1-22	9 Oil Pan, Oil Pump, and Oil Filter	1-41
3 Engine Supports	1-24	10 Exhaust System	1-42
4 Manifolds, Cylinder Heads, and Valves	1-25		
5 Crankshaft Damper, Cylinder Front Cover, and Timing Chain.....	1-30		
6 Camshaft, Bearings, and Tappets	1-32		
7 Flywheel, Crankshaft, Connecting Rods, and Piston Assemblies	1-33		

The service procedures given are for the engine installed in the chassis unless otherwise noted. Cleaning, inspection, repair, and overhaul procedures are covered in Part 1, "General Engine Service."

1 DESCRIPTION

The 223 Six (Figs. 1 and 2) is a 6-cylinder engine with a piston displacement of 223 cubic inches and a compression ratio of 8.3:1. The letter "J" at the beginning of the serial number on the patent plate designates a 223 Six engine.

MANIFOLDS

A chamber (heat riser) is cast into the intake manifold center section between the carburetor and exhaust manifold. A thermostatically controlled valve, located in the exhaust manifold, directs exhaust gases into this area to provide the heat necessary to assist in vaporizing the incoming fuel mixture.

CYLINDER HEAD AND BLOCK

The cylinder head carries the valves, valve rocker arm shaft assembly, manifold assembly, ignition coil, the water outlet and thermostat. Valve

guides are cast integral in the head.

Both the intake and exhaust valve assemblies are the rotating-type which rotate each time the valve opens and closes. Lubrication of the valve stems is controlled by umbrella-type valve stem seals which fit over the top of the valve stems. The valve springs have equal coil spacing which provides more positive valve action at high engine speed. Easy maintenance of valve lash is afforded by self locking adjusting screws.

The camshaft is supported by four insert-type bearings pressed into the block. It is driven by a sprocket and timing chain in mesh with a sprocket on the crankshaft. Camshaft thrust is controlled by a thrust plate located between the camshaft sprocket and the front journal of the camshaft. An eccentric, made integral with the camshaft, operates the fuel pump.

The tappets are the solid steel, mushroom-type. The push rods are one-piece tubular steel with oil cushioned sockets.

The crankshaft is supported by four insert-type main bearings. Crankshaft end thrust is controlled by the flanges of the No. 3 main bearing.

The forged steel, "I" section connecting rods contain a bronze piston pin bushing. The connecting rod bearings are the insert-type.

The aluminum alloy, three ring, flat head-type pistons are of the auto-thermic design. This design provides controlled piston expansion which allows closer initial piston fits without binding or excessive friction. The top compression ring is chrome-plated and the lower compression ring is phosphate-coated for extra protection against wear and scuffing. The oil con-

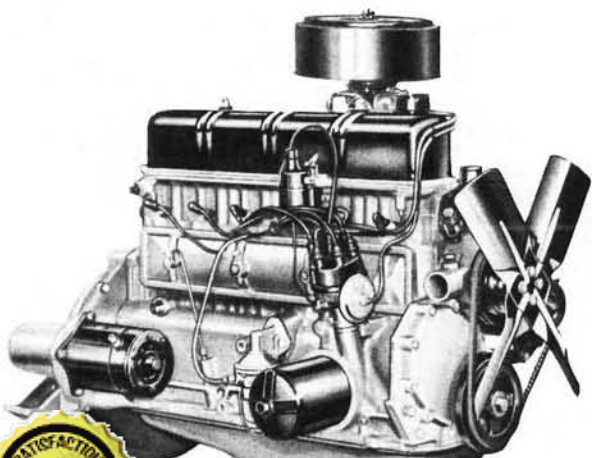

1302-B

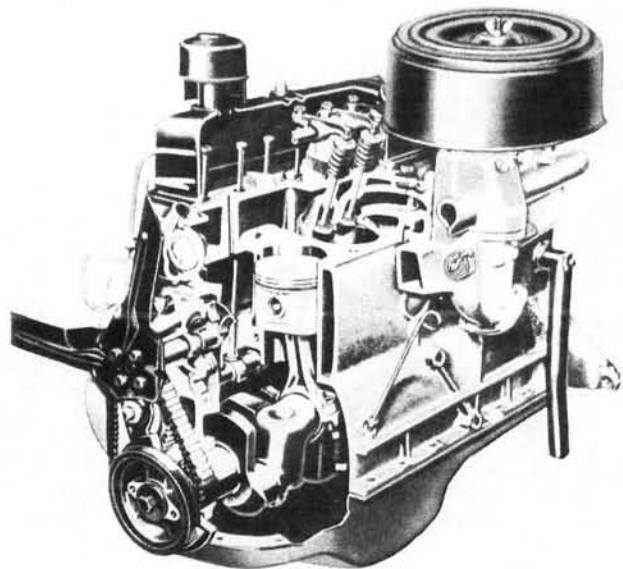

1294-B

FIG. 2—223 Six Engine—Left Sectional View

100% SATISFACTION GUARANTEED

BUY IT NOW!

Click Here To Order

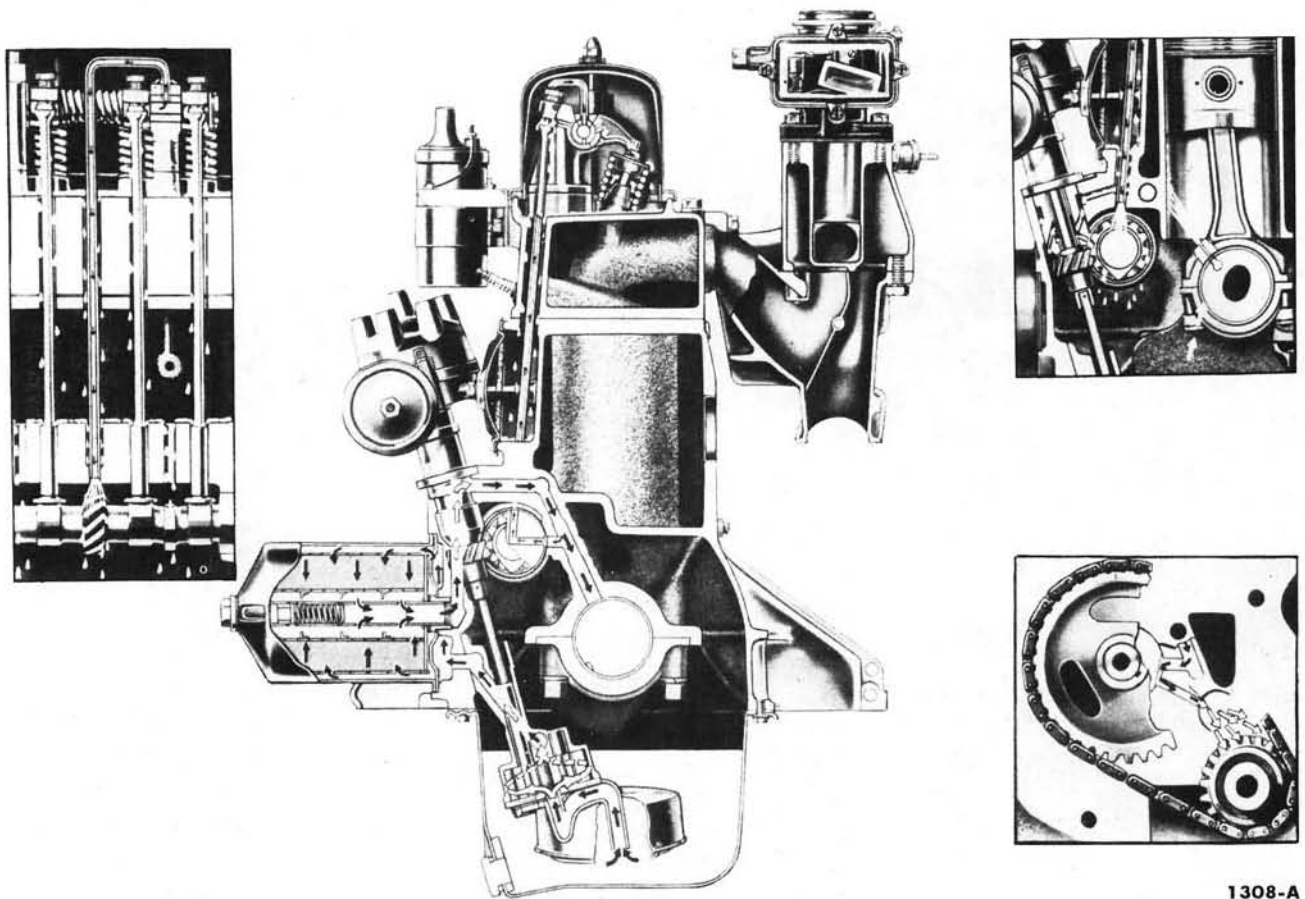

1308-A

FIG. 3—Lubrication System

trol ring assembly consists of a serrated spring and two chrome-plated steel rails.

ENGINE LUBRICATION SYSTEM

Oil from the oil pan sump is forced through the pressure-feed lubrication system (Fig. 3) by a gear-type pump mounted inside the crankcase. The pump is driven by the distributor through an intermediate drive shaft. A spring loaded relief valve in the pump limits the maximum pressure of the system. The oil relieved by the valve is directed back to the intake side of the pump.

The engine is equipped with a full flow filter which filters the entire output of the pump before the oil enters the engine. A built in by-pass provides oil to the engine in case the filter element becomes clogged. The by-pass is

faces of the valve is not great enough to overcome the spring pressure behind the valve. Therefore, no oil flows through the by-pass. When the element is dirty and will not permit a sufficient flow of oil, the pressure acting on the inner face of the valve drops. If the pressure difference between the valve faces is great enough to overcome spring pressure, the valve will open. Oil then bypasses the element, maintaining an emergency supply of oil to the engine. An anti-drain back diaphragm, mounted on the block, prevents a reverse flow of oil when the engine is stopped.

The main oil gallery supplies oil to all the camshaft and main bearings through a drilled passage in each main bearing web.

The timing chain and sprockets are lubricated through a flat on the No. 1 camshaft bearing.

Oil slingers are provided to prevent leakage by directing oil away from the crankshaft front and rear oil seals. The front slinger is located between the crankshaft damper and the

crankshaft sprocket and throws the oil onto the timing chain. The oil then drips into the oil pan. The rear slinger is part of the crankshaft and deflects oil into the slinger trough which empties the oil back into the oil pan.

Cylinder walls, pistons, and piston pins are lubricated through a drilled hole in each connecting rod which indexes with a drilled hole in the connecting rod journal of the crankshaft.

Oil under reduced pressure is fed to the valve rocker arm shaft assembly through a drilled passage in the cylinder block at the No. 3 camshaft bearing which indexes with a hole in the cylinder head. An oil inlet tube directs the oil into the hollow valve rocker arm shaft through the No. 6 valve rocker arm support. The oil from the shaft flows through drilled holes in each rocker arm to lubricate the rocker arm bushing and the valve and ball end of the rocker arm. The excess oil spirals down the rotating push rod and assists in lubricating the tappet and push rod seat. An oil outlet tube exhausts excess oil from the

100% SATISFACTION GUARANTEED

BUY IT NOW!

Click Here To Order

PayPal American Express Cards DISCOVER NOVUS MasterCard VISA

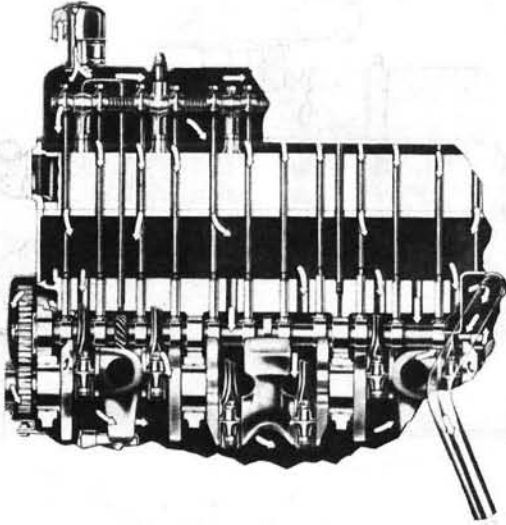

1309-B

FIG. 4—Crankcase Ventilation

valve rocker arm shaft to lubricate the distributor lower bushing and distributor drive gears. The oil outlet tube is located at the No. 1 rocker arm support. The oil from each rocker arm drains into the push rod chamber through holes provided in the cylinder head.

The oil in the push rod chamber drains back into the oil pan through an opening at the back of the block.

CRANKCASE VENTILATION

Ventilating air (Fig. 4) is provided by the combination oil filler and breather cap located on the front of the valve rocker arm cover. The oil filler cap contains a maze filtering element.

From the filler cap, the filtered air flows into the front section of the

valve rocker arm chamber. There are relatively few contaminating vapors at this point and the air has a chance to normalize its temperature before contacting contaminating vapors originating in the crankcase. This warm ventilating air minimizes the formation of crankcase sludge. The ventilating air moves down past the push rods into the crankcase. Air is diverted from the front section of the crankcase through holes in the front of the cylinder block wall to ventilate the timing chain chamber. The air from the crankcase is then directed into the crankcase ventilation tube by the rotating action of the crankcase.

COOLING SYSTEM

The coolant is drawn from the lower tank of the radiator by the

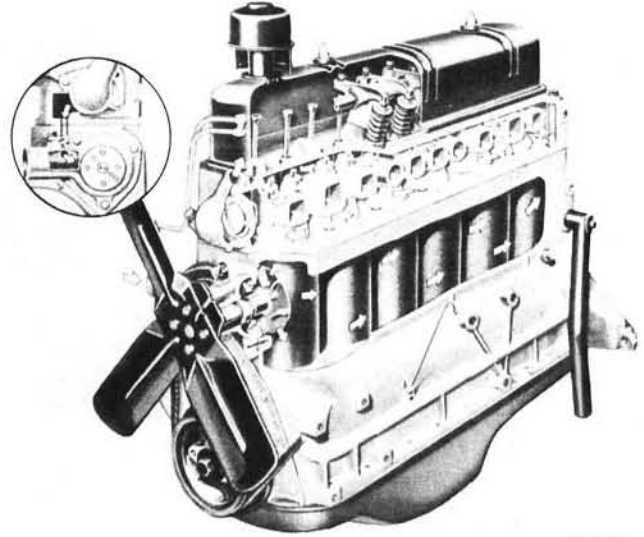

1435-B

FIG. 5—Cooling System

water pump which delivers the coolant to the cylinder block (Fig. 5).

As the coolant enters the block, it travels through cored passages to cool the entire length of each cylinder wall. Upon reaching the rear of the cylinder block, the coolant is directed upward into the cylinder head where it cools the combustion chambers, valves, and valve seats on its return to the front of the engine.

At this point, the coolant flows into the water outlet connection, past the water thermostat if it is open, into the upper tank of the radiator. If the thermostat is closed, a small portion of the coolant is bypassed through a pipe which returns the coolant to the water pump for recirculation. The entire system is pressurized to 7 psi with the use of a pressure-type radiator cap.

2 ENGINE REMOVAL AND INSTALLATION

Engine removal and installation procedures are separated according to truck body styles. The procedures for the Courier and Ranchero are the same as for the car; therefore, refer to the 1958 Ford Car Shop Manual.

2. Remove the air cleaner, then tape the carburetor air horn closed. Disconnect the choke control cable at the carburetor, the accelerator shaft to accelerator bellcrank rod at the bellcrank, and the transmission throttle control rod at the bellcrank (automatic transmission). Remove the accelerator retracting spring. Disconnect the exhaust manifold at the muffler inlet pipe and remove the inlet pipe to engine bracket bolt. Disconnect the flexible fuel line at the fuel

tank line, then install a cap on the fuel tank line. Disconnect the generator wires at the generator. Remove the engine ground strap at the flywheel or converter housing, and remove the flywheel or converter housing to engine block and engine rear plate retaining bolts.

3. Remove the drive belt(s), then remove the fan, spacer, and pulley.

4. Disconnect the heater hoses at the engine. Disconnect the water temperature and oil pressure sending unit

F-SERIES

100% SATISFACTION GUARANTEED

BUY IT NOW!

Click Here To Order

PayPal American Express Cards Discover Novus MasterCard VISA

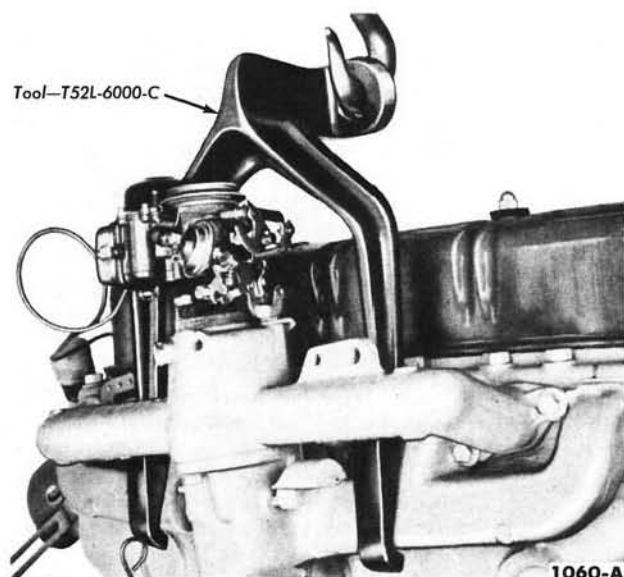

FIG. 6—Engine Lifting Hook

wires at the sending units. Disconnect the coil primary wires. Remove the starter.

On conventional drive and overdrive equipped trucks, remove the flywheel housing inspection cover and support the transmission with a jack.

On trucks with an automatic transmission, support the transmission with a jack, then remove the converter housing lower access cover and the flywheel to converter bolts. Secure the converter assembly in the housing. Disconnect the transmission oil cooler inlet and outlet lines at the engine.

5. Attach the engine lifting hook (Fig. 6). Remove the engine right and left front support to frame bracket bolts. Lift the engine out of the engine compartment and install it on a work stand (Fig. 7).

INSTALLATION

1. Place a new gasket over the exhaust manifold to muffler inlet pipe studs. Lower the engine carefully into the chassis. Make sure the studs on the exhaust manifold are aligned with the holes in the muffler inlet pipe and the dowels in the block engage the holes in the flywheel or converter housing.

On trucks with an automatic transmission, start the converter pilot into crankshaft. Install the converter

converter bolts. Tighten the bolts to specifications. Install the converter housing inspection cover. Connect the oil cooler inlet and outlet lines.

On conventional drive or overdrive equipped trucks, start the transmission main drive gear into the clutch disc. It may be necessary to adjust the position of the transmission in relation to the engine if the input shaft will not enter the clutch disc. **If the engine "hangs up" after the shaft enters, turn the crankshaft slowly (transmission in gear) until the shaft splines mesh with the clutch disc splines.** Install the flywheel housing to engine block and engine rear plate retaining bolts. Remove the support from the transmission. Install the flywheel housing cover.

2. Position the engine ground strap and install the remaining engine rear plate retaining bolts. Install the engine right and left front support bolt and nut, and tighten the nut to 35-45 foot-pounds torque.

3. Install the exhaust manifold to muffler inlet pipe retaining lockwashers and nuts, then tighten the nuts to 23-28 foot-pounds torque. Install the inlet pipe to engine bracket bolt. Connect the generator wires. Remove the cap from the fuel tank line and connect the flexible fuel line. Install the accelerator retracting spring. Connect the transmission throttle control rod at the accelerator bellcrank (automatic transmission). Connect the accelerator shaft to bellcrank rod at the

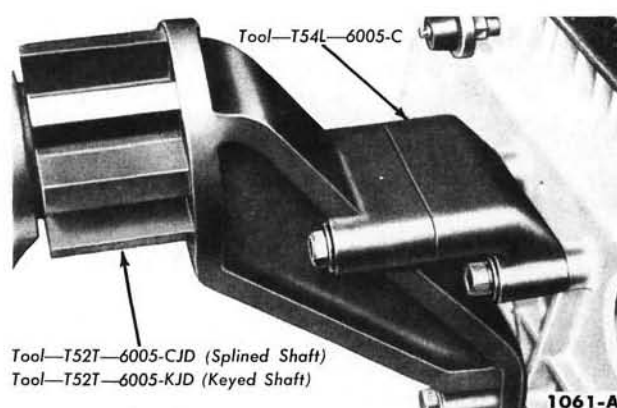

FIG. 7—Engine Mount

bellcrank and the choke control cable at the carburetor. Remove the tape from the carburetor air horn, then install the air cleaner.

4. Install the pulley, spacer, and fan, then install and adjust the drive belt(s). Install the radiator.

5. Install the starter. Connect the ignition coil primary wires, the oil pressure and water temperature sending unit wires, and the heater hoses.

6. Fill and bleed the cooling system. Fill the crankcase with the proper grade and quantity of engine oil. Install the hood. Run the engine at fast idle and check all gaskets and hose connections for leaks.

7. On trucks with an automatic transmission, adjust the throttle linkage.

P-SERIES

REMOVAL

1. Drain the cooling system and the crankcase. Remove the driver's seat assembly, the master cylinder inspection cover, and the steering column cover plates. Disconnect the accelerator pedal at the accelerator assembly, and the wires from the headlight beam selector switch.

2. Remove the left wheel house panel and the center floor plate. Remove the screws fastening the right side of the engine rear cover panel to the right wheel house panel. Remove the bolts and nuts retaining the rear flange of the engine rear cover to the removable frame cross member and the center floor plate front bracket. Wedge the right and left frame gussets open so the rear flange of the engine rear cover plate will clear the slots. Remove the cover plate. Remove the air cleaner.

100% SATISFACTION GUARANTEED

BUY IT NOW!

Click Here To Order

PayPal American Express Discover MasterCard VISA

3. Remove the accelerator bracket assembly, the accelerator retracting spring, and the carburetor. Disconnect the exhaust manifold at the muffler inlet pipe and remove the inlet pipe to engine bracket bolt. Disconnect the generator wires at the generator. Disconnect the flexible fuel line at the fuel tank line, then install a cap on the fuel tank line.

4. Disconnect the engine temperature and oil pressure sending unit wires at the sending units. Disconnect the coil primary wires. Disconnect the battery ground cable at the battery. Remove the starter.

5. Remove the fan blade and bracket as an assembly, and remove the radiator.

6. Remove the engine right and left front support to frame bracket bolts. Remove the flywheel or converter housing cover. Remove the flywheel housing or converter housing to engine block and engine rear plate retaining bolts. Remove the engine right and left rear support capscrews. Remove the engine crankcase ventilation tube. Support the transmission with a jack.

7. On trucks with an automatic transmission, disconnect the transmission oil cooler inlet and outlet hoses at the engine. Drain the transmission and remove the filler tube. Install the drain plugs in the torque converter.

8. Remove the engine from the truck and install it on a work stand.

INSTALLATION

1. Place a new gasket over the exhaust manifold to muffler inlet pipe studs. Lower the engine carefully into the chassis. Make sure the studs on

the exhaust manifold are aligned with the holes in the muffler inlet pipe and the dowels in the block engage the holes in the converter or flywheel housing.

On trucks with an automatic transmission, start the converter pilot into the crankshaft. Remove the retainer securing the converter, then install the converter to flywheel retaining bolts. Install the converter housing to engine block and engine rear plate retaining bolts. Install the converter housing cover plate. Install the automatic transmission filler tube. Connect the transmission oil cooler hoses. Fill the transmission with Automatic Transmission Fluid—Type A.

On conventional drive or overdrive equipped trucks, start the transmission main drive gear into the clutch disc. It may be necessary to adjust the position of the transmission in relation to the engine if the input shaft will not enter the clutch disc. **If the engine "hangs up" after the shaft enters, turn the crankshaft slowly (transmission in gear) until the shaft splines mesh with the clutch disc splines.** Install the flywheel housing to engine block and engine rear plate retaining bolts. Remove the transmission support. Install the flywheel housing cover.

2. Install the engine rear support capscrews, then install safety wire on the capscrews. Install the engine front support to the frame bracket, then tighten the nuts to specifications.

3. Install the fan and bracket and adjust the tension of the drive belts. Install the radiator.

4. Remove the cap from the fuel tank line and connect the flexible fuel

line. Install the exhaust manifold to muffler inlet pipe retaining lockwashers and nuts, then tighten the nuts to 23-28 foot-pounds torque. Connect the inlet pipe to engine bracket. Install the carburetor, the accelerator bracket assembly, and the accelerator retracting spring. Connect all the carburetor linkage and lines.

5. Install the starter, connect the coil primary wires, the engine temperature and oil pressure sending unit wires, the generator wires, and the battery cable. Install the crankcase ventilation tube.

6. Install the frame cross member. Position the engine cover assembly and the engine rear panel assembly and install the flange of the engine cover rear panel between the frame gussets and the cross member. Remove the wedges.

7. Install the right side of the engine rear cover panel to the right wheel house panels. Install the bolts and nuts retaining the rear flange of the engine rear cover to the frame cross member and the center floor plate front bracket.

8. Connect the headlight beam selector switch wires and the accelerator pedal.

9. Install the engine left cover to wheel house panel, the steering column cover plates, and the master cylinder inspection cover. Install the driver's seat assembly.

10. Fill and bleed the cooling system. Fill the crankcase with the proper grade and quantity of engine oil. Operate the engine at fast idle and check for coolant and oil leaks.

On trucks with an automatic transmission, adjust the throttle linkage.

3 ENGINE SUPPORTS

The engine is supported on each side at the front (Fig. 8) and rear (Fig. 9) of the crankcase.

ENGINE FRONT SUPPORT REPLACEMENT

(ENGINE IN CHASSIS)

1. Remove the nut, washer, bolt

2. Place the upper insulator in position on each frame bracket, then lower the engine.

3. Install the lower insulator, bolt, washer, and nut on each side of the engine. Tighten the bolts to specifications.

ENGINE REAR SUPPORT REPLACEMENT

1. Remove the nut, bolt, lower in-

ulator, and spacer from each rear support. Raise the rear of the engine, then remove the insulators.

2. Place a new upper insulator in position on each side of the engine, then lower the engine.

3. Install the spacer, the lower insulator, bolt, and nut on each side of the engine. Tighten the bolts to specifications.

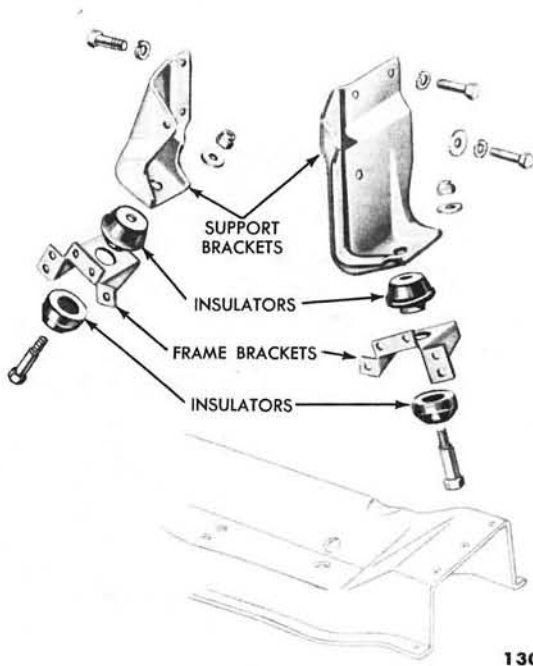

1305-A

FIG. 8—Engine Front Support

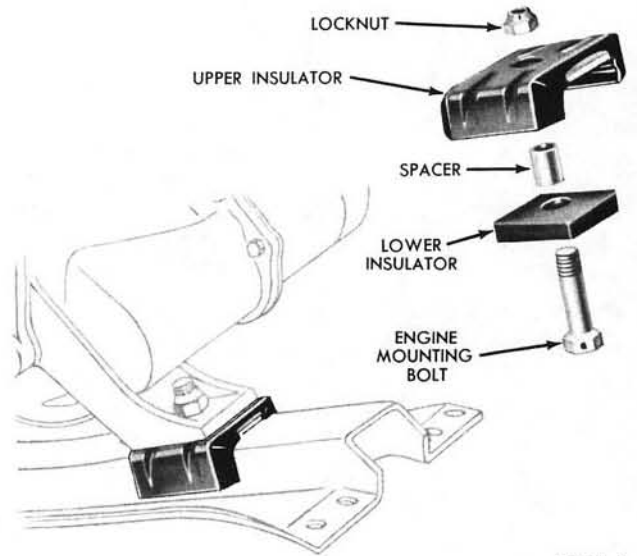

1304-A

FIG. 9—Engine Rear Support

4 MANIFOLDS, CYLINDER HEADS, AND VALVES

MANIFOLDS

The manifold assembly is shown in Fig. 10.

REMOVAL

1. Remove the air cleaner, then tape the carburetor air horn closed.

On trucks with an automatic transmission, disconnect the throttle control rod and the accelerator assembly connecting link at the accelerator bracket. Disconnect the accelerator

retracting spring at the block mounted bracket, then remove the bracket.

On conventional drive and overdrive units, disconnect the accelerator retracting spring and the accelerator rod assembly at the bellcrank.

2. Disconnect the vacuum line at the intake manifold. Disconnect the choke control cable, the fuel inlet line, and the distributor vacuum line at the carburetor, then remove the carburetor and gasket.

3. Disconnect the muffler inlet pipe from the exhaust manifold. Remove the bolts fastening the manifold to the head, and lift the manifold assembly from the head. Remove the gaskets and sleeves.

4. Remove the nuts and bolt joining the intake and exhaust manifolds, then separate the manifolds.

INSTALLATION

1. Place the intake manifold over the studs on the exhaust manifold. Install the lockwashers, nuts and bolt, then tighten them finger tight.

2. Install new intake manifold gaskets using new sleeves, if necessary, in the cylinder head ports. Place a

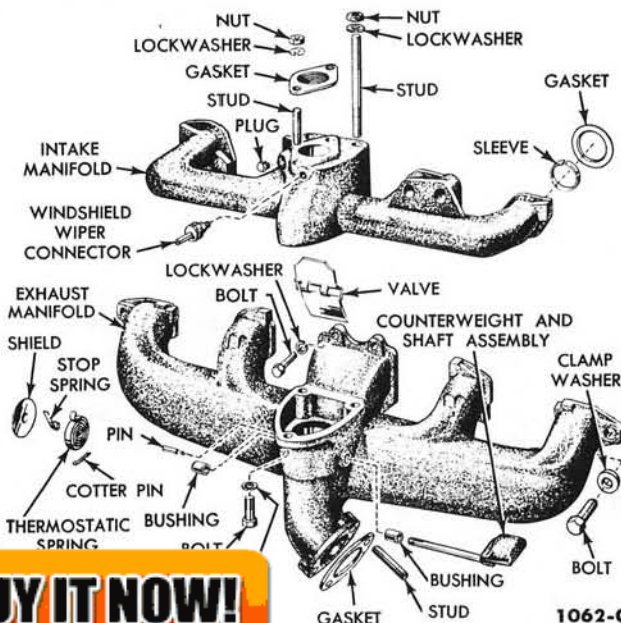

1062-C

100% SATISFACTORY GUARANTEED

BUY IT NOW!

Click Here To Order

assembly

PayPal American Express Cards DISCOVER NOVUS MasterCard VISA

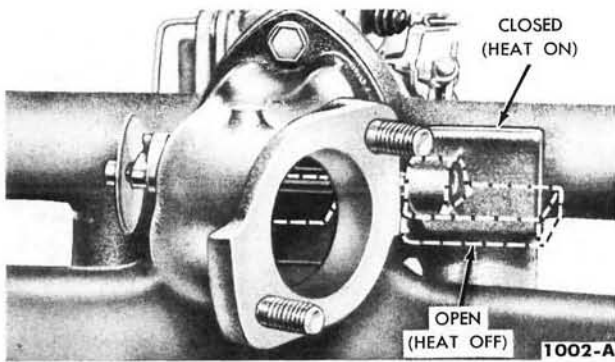

FIG. 11—Exhaust Gas Control Valve

new exhaust manifold to muffler inlet pipe gasket over the studs on the exhaust manifold. Coat the mating surfaces lightly with graphite grease, then place the manifold assembly in position against the head. **Make sure the port openings in the manifold assembly are aligned with the port openings in the cylinder head and that none of the steel gaskets have become dislodged.**

3. Install the attaching washers and bolts, then tighten the bolts to 23-28 foot-pounds torque, tightening from the center to the ends. Tighten the bolt and nuts joining the intake and exhaust manifolds to 23-28 foot-pounds torque. Install the exhaust manifold to muffler inlet pipe lockwashers and

nuts, then tighten the nuts to 23-28 foot-pounds torque.

4. Position the carburetor gasket on the intake manifold, then install the carburetor. Tighten the carburetor retaining nuts to 12-15 foot-pounds torque. Connect the vacuum line to the intake manifold. Connect the choke control cable, the fuel inlet line, and the distributor vacuum line to the carburetor.

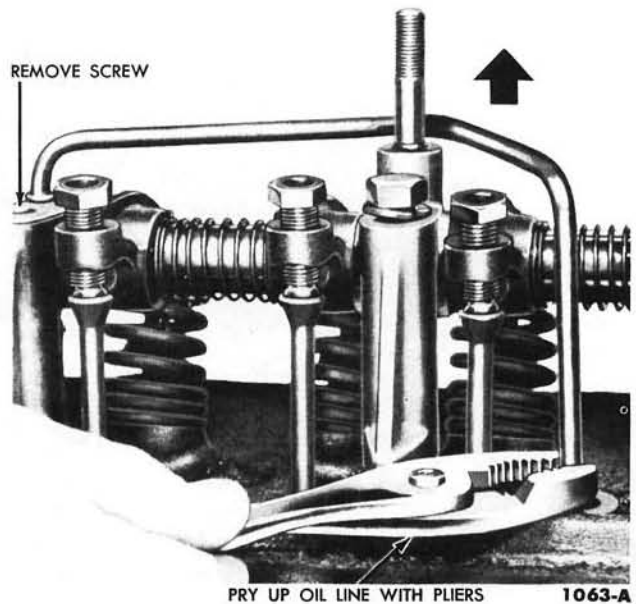

FIG. 12—Oil Line Removal

On trucks with an automatic transmission, install the accelerator retracting spring bracket, then connect the spring. Connect the accelerator assembly connecting link and the throttle control rod.

On conventional drive and over-drive units, connect the accelerator retracting spring and the accelerator rod assembly.

5. Remove the tape from the carburetor air horn, then install the air cleaner.

EXHAUST GAS CONTROL VALVE REPLACEMENT

The exhaust gas control valve is located in the outlet of the exhaust manifold. Normally, it does not require replacement unless it becomes inoperative due to excessive corrosion or damage.

1. Remove the manifold assembly and separate the intake and exhaust manifolds. Before removing the control valve assembly, note the position of the counterweight in relation to the valve plate. Remove the cotter pin, shield, stop spring and thermostatic spring from the front end of the shaft.

2. Using an acetylene torch in the inside of the manifold, cut the shaft



removal



BUY IT NOW!

Click Here To Order



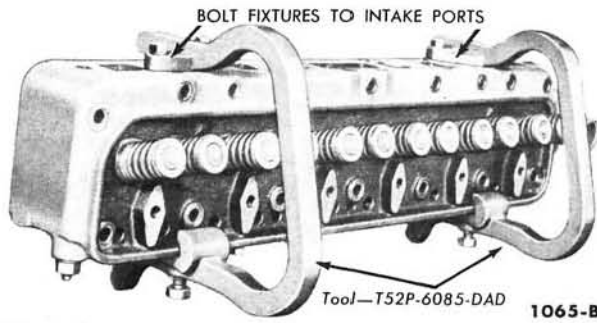

FIG. 14—Cylinder Head Holding Fixture

on both sides of the valve plate. **Use caution to avoid damage to the shaft bearing bores.** Remove the valve and shaft pieces.

3. Clean the bushings of corrosion and repair any damage that may have occurred. Replace the bushings if necessary. When new bushings are installed, there should be a distance of $2\frac{3}{8}$ inches from the inside edge of one bushing to the inside edge of the other bushing. The bushing should be equally spaced within the counterbores. After installation, ream the bushings with a $\frac{1}{16}$ -inch reamer. Lubricate the new shaft and bushings with a penetrating oil and graphite mixture.

4. Insert the shaft through the bushings and valve plate. Rotate the shaft in the valve plate until the counterweight is in the normal "up" (heat on) position (Fig. 11).

5. Tack weld the valve to the shaft, then move the assembly back and forth to check for a binding condition. If there is no binding, weld the valve to the shaft in the original manner. The shaft and valve are stainless steel to minimize corrosion and/or damage by excessive heat.

6. Install the thermostatic spring in the shaft slot. Wind the spring $\frac{3}{4}$ turn and hook the open end of the spring over the stop pin. The thermostatic spring should hold the valve in the closed or "heat on" position (i.e. in the proper position to direct the flow of gases into the heat riser).

7. Install the stop spring, shield, and cotter pin. Lubricate the shaft bushings while operating the valve manually to replace the original lubrication lost by the welding operation.

carburetor air horn closed. Disconnect the radiator upper hose at the radiator, the heater hose at the water outlet housing, the oil pressure and water temperature sending unit wires at the sending units, and the battery ground cable at the cylinder head. Disconnect the carburetor fuel inlet line and the vacuum line at the fuel pump, and the distributor vacuum line at the distributor. Disconnect the high tension lead at the coil, then remove the coil from the head and move it to one side. Remove the distributor cap. Disconnect the spark plug wires, then remove the spark plugs.

On trucks with an automatic transmission, disconnect the throttle control rod and the accelerator assembly connecting link at the accelerator bracket. Disconnect the accelerator retracting spring at the block mounted bracket, then remove the bracket.

On conventional drive and over-drive units, disconnect the accelerator retracting spring and the accelerator rod assembly at the bellcrank.

2. Disconnect the fuel inlet line and the distributor vacuum line at the carburetor, and the vacuum line at the intake manifold, then remove the three lines as an assembly. Disconnect the choke control cable at the carburetor.

3. Remove the valve rocker arm cover. Remove the cap screw and bracket from the No. 6 valve rocker arm support. Pull the oil inlet line out of the support, then pull it out of the block with pliers (Fig. 12). Be careful not to damage the line. Remove the cap screws from the No. 1 valve rocker arm support, then remove the oil outlet line and bracket. Loosen all rocker arm adjusting screws to remove the valve spring

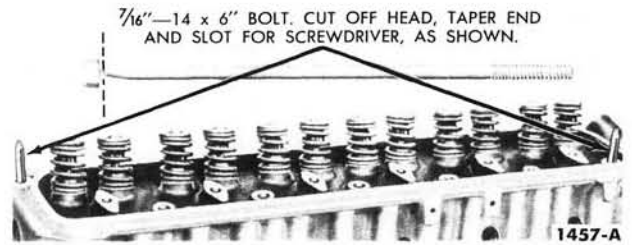

FIG. 15—Cylinder Head Guide Studs

load from the rocker arms, then remove the valve rocker arm shaft assembly. Remove the valve push rods in sequence and identify them so they can be installed in their original positions (Fig. 13).

4. Remove the manifold to cylinder head bolts, and pull the manifold assembly away from the cylinder head. Brace the assembly so the inlet pipe will not be damaged. Install the cylinder head holding fixtures for convenience in lifting the head and to protect the gasket surfaces (Fig. 14). Remove all cylinder head bolts. Install the cylinder head guide studs (Fig. 15). Lift the cylinder head assembly off the engine. **Do not pry between the head and block as the gasket surfaces may become damaged.**

VALVE ROCKER ARM SHAFT DISASSEMBLY

1. Remove the cotter pins from each end of the rocker arm shaft, and remove the flat washers and spring washers. Slide the rocker arms, springs, and supports off the shaft. Be sure to identify the parts.

2. If it is necessary to remove the plugs from each end of the shaft, drill or pierce the plug on one end, then use a steel rod to knock out the plug on the opposite end. Working from the open end, knock out the remaining plug.

VALVE ROCKER ARM SHAFT ASSEMBLY

1. Oil all moving parts with engine oil.

2. If the plugs were removed from the end of the shaft, use a blunt tool or large diameter pipe punch and install a plug, cup side out, in each end of the rocker arm shaft.

3. Install a flat washer, spring washer, another flat washer, and a cotter pin on one end of the shaft.

100% SATISFACTION GUARANTEED

BUY IT NOW!

Click Here To Order

PayPal American Express Discover MasterCard VISA

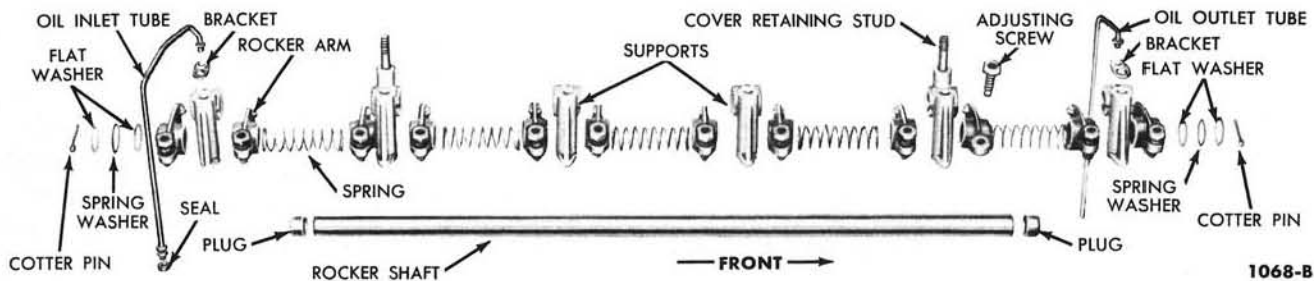

FIG. 16—Valve Rocker Arm Shaft Assembly

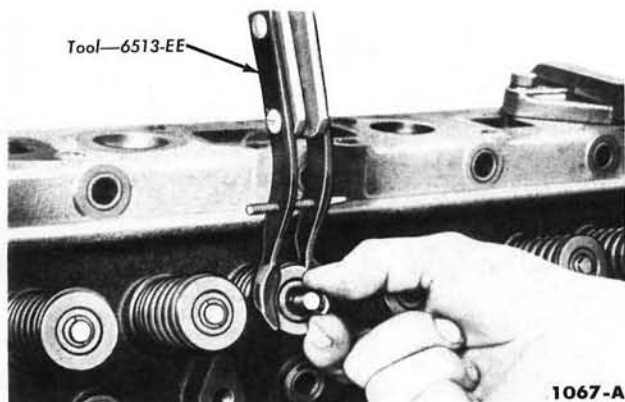

FIG. 17—Valve Stem Lock Removal or Installation

4. Install the rocker arms, supports, and springs (Fig. 16). Install the remaining flat washers with the spring washer between them, and install the cotter pin.

CYLINDER HEAD DISASSEMBLY

1. Remove deposits from the combustion chambers and valve heads with a scraper and a wire brush before removing the valves. **Be careful not to scratch the cylinder head gasket surface.**

2. Compress the valve spring (Fig. 17), then remove the valve retainer locks and release the spring. Remove the sleeve, spring retainer, spring, stem seal, and valve. Discard all valve stem seals. Identify all valve parts.

CYLINDER HEAD ASSEMBLY

1. Install each valve in the port from which it was removed or to which it was fitted. Install a new stem seal on each valve.

3. Measure the assembled height of the valve springs from the surface of the cylinder head spring pad to the underside of the spring retainer with dividers (Fig. 18). Check the dividers against a scale. If the assembled height is greater than $1\frac{13}{16}$ inches, install the necessary 0.030-inch thick spacer(s) between the cylinder head spring pad and the valve spring to bring the assembled height to the recommended dimension of $1\frac{25}{32}$ – $1\frac{13}{16}$ inches. **Do not install spacers unless necessary. Use of spacers in excess of recommendations will result in overstressing the valve springs which will lead to excessive load loss and spring breakage.**

CYLINDER HEAD INSTALLATION

1. Clean deposits and gasket sealer residue from the head and block gasket surfaces. Inspect the head for any damage and repair as necessary. Apply a coating of cylinder head gasket sealer to both sides of a new gasket. Use the brush furnished to spread the sealer evenly over the entire gasket surface. Position the gasket over the guide studs on the cylinder block.

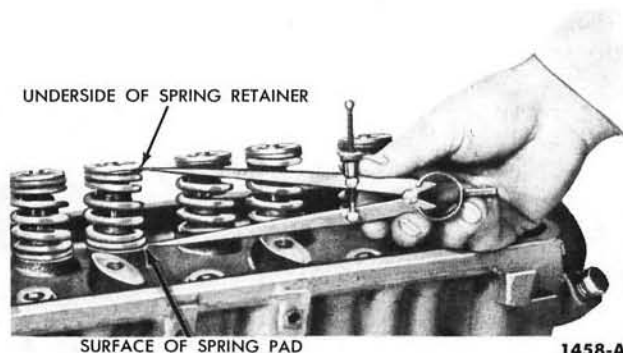

FIG. 18—Valve Spring Assembled Height

2. Lift the cylinder head over the guides and slide the head down carefully. Before installing the cylinder head bolts, coat the threads of each bolt with a small amount of water resistant sealer. Install, but do not tighten, two bolts at opposite ends of the head to hold the head and gasket in position. Remove the guides, then install the remaining bolts. Remove the cylinder head holding fixtures.

3. The cylinder head bolt tightening procedure is performed in three progressive steps. Tighten the bolts to 55 foot-pounds torque in the proper sequence (Fig. 19), then tighten them to 65 foot-pounds torque in the same sequence. Finally, tighten the bolts to 75 foot-pounds torque in the same sequence. **After the cylinder head bolts have been tightened to specifications, the bolts should not be disturbed.**

4. Install the push rods in their proper sequence, positioning the lower end of the rods in the tappet sockets. Position the valve rocker arm shaft assembly on the head, then install the oil outlet line, bracket, and retaining screw on the No. 1 support. Make sure the oil line enters the shaft locating hole. Install a new "O" ring seal on the lower end of the oil inlet

100% SATISFACTION GUARANTEED

BUY IT NOW!

Click Here To Order

PayPal American Express Discover Novus MasterCard VISA

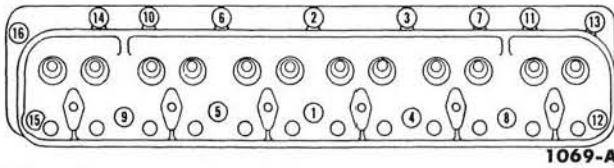

FIG. 19—Cylinder Head Bolt Tightening Sequence

line, then position the line in the No. 6 support. Make sure the lower end of the oil line "O" ring seal is in the oil supply counterbore, then install the bracket and support bolt. Tighten all the retaining bolts to 45-55 foot-pounds torque. Perform a preliminary (cold) valve lash adjustment.

5. Install the manifold to cylinder head bolts and tighten them to 23-28 foot-pounds torque. Position the two vacuum lines and the carburetor fuel inlet line on the engine. Connect the distributor vacuum line and the carburetor fuel inlet line at the carburetor, and the manifold vacuum line at the manifold. Connect the choke control cable. Remove the tape from the carburetor air horn.

On trucks with an automatic transmission, install the accelerator retracting spring bracket on the block, then connect the spring. Connect the throttle control rod and the accelerator assembly connecting link.

On conventional drive and over-drive units, connect the accelerator rod assembly and the accelerator retracting spring.

6. Install the ignition coil, spark plugs, and the distributor cap. Connect the spark plug wires and the coil high tension lead. Connect the carburetor fuel inlet line and the vacuum line at the fuel pump, and the distributor vacuum line at the distributor. Connect the battery ground cable, the oil pressure and water temperature sending unit wires, the heater hose, and the radiator upper hose. Fill and bleed the cooling system.

7. Start the engine and operate it for a minimum of 30 minutes at approximately 1200 rpm to stabilize engine temperatures. Check the valve lash with the engine idling and adjust the lash if necessary.

8. Coat one side of the valve rocker arm cover gasket with oil re-

- STEP 1—** SET NO. 1 PISTON ON T.D.C. AT END OF COMPRESSION STROKE, ADJUST NO. 1 INTAKE AND EXHAUST
STEP 4— ADJUST NO. 6 INTAKE AND EXHAUST

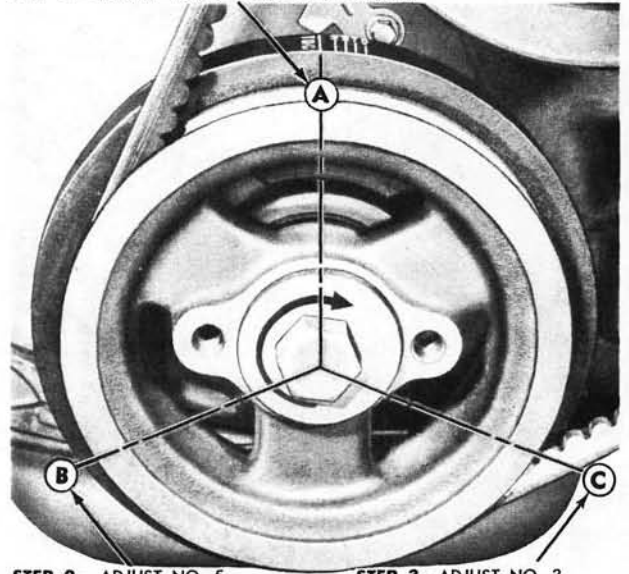

- STEP 2—** ADJUST NO. 5 INTAKE AND EXHAUST
STEP 3— ADJUST NO. 3 INTAKE AND EXHAUST
STEP 5— ADJUST NO. 2 INTAKE AND EXHAUST
STEP 6— ADJUST NO. 4 INTAKE AND EXHAUST
 1421-A

FIG. 20—Preliminary Valve Lash Adjustment

the studs making sure they are centered in the cover openings. Tighten the nuts to 2.0-2.5 foot-pounds torque. Install the air cleaner.

VALVE LASH ADJUSTMENT

It is very important that the valve lash be held as close as possible to the correct specifications. If the lash is set too close, the valve will open too early and close too late, resulting in rough engine idle. Burning and warping of the valves will occur also because the valves cannot make firm contact with the seats long enough to cool properly. If the lash is excessive, it will cause the valves to open too late and close too early causing valve bounce. In addition, damage to the camshaft lobe is likely because the tappet foot will not follow the pattern of the camshaft lobe, causing a shock contact between these two parts.

If the cylinder head or the valve rocker arm shaft assembly has been removed and installed, it will be necessary to make a preliminary (cold) valve lash adjustment before starting the engine. If the adjustment is made for an engine tune-up, follow the final adjustment procedure.

The cylinders are numbered from front to rear, 1-2-3-4-5-6. The valves are arranged from front to rear, E-I-I-E-I-E-E-I-E-I-E.

PRELIMINARY ADJUSTMENT

1. Turn all the valve adjusting screws until interference is noted between the screw and the rocker arm, then check the torque required to turn the screw further. If the torque required to turn a screw is less than 3 foot-pounds (36 inch pounds), try a new self locking adjusting screw. If this is still unsatisfactory, replace the rocker arm and adjusting screw.

2. Make two chalk marks on the crankshaft damper (Fig. 20). Space the marks approximately 120° apart so that with the timing mark, the damper is divided into three equal parts (120° represents 1/3 of the distance around the damper circumference).

3. Rotate the crankshaft until No. 1 piston is near T.D.C. at the end of the compression stroke. Number 1 piston is on T.D.C. at the end of the compression stroke when both valves are closed and the timing mark on the crankshaft damper is in line with the timing pointer.

100% SATISFACTION GUARANTEED

BUY IT NOW!

Click Here To Order

PayPal American Express Discover MasterCard VISA

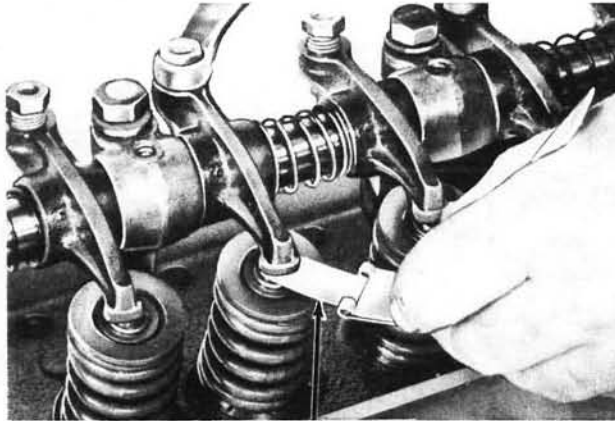

Step-Type Feeler Gauge

1397-A

FIG. 21—Valve Lash Adjustment

4. Using a step-type feeler gauge (“go” and “no go”), adjust the intake and exhaust valve lash for No. 1 cylinder (Fig. 21). The preliminary (cold) intake and exhaust valve lash should be set at 0.019 inch.

5. Repeat this procedure for the remaining set of valves, turning the crankshaft $\frac{1}{3}$ turn at a time, in the direction of rotation, while adjusting the valves in the firing order sequence (1-5-3-6-2-4).

FINAL ADJUSTMENT

Operate the engine for a minimum of 30 minutes at approximately 1200 rpm to stabilize engine temperatures. With the engine idling, check the valve lash. Adjust the lash if necessary (Fig. 21). The final (hot) intake and exhaust valve lash should be 0.019 inch.

5 CRANKSHAFT DAMPER, CYLINDER FRONT COVER, AND TIMING CHAIN

CRANKSHAFT DAMPER

REMOVAL

1. On P-series trucks, remove the hood, and remove the grille, headlamps, parking lamps, wind deflector, and hood lower weatherstrip as an assembly.

2. On all models, remove the radiator, fan, spacer, drive belt(s), and pulley.

3. On B- and F-series trucks, remove the grille to hood lock support bracket retaining bolt.

4. On all models, remove the cap screw and washer from the end of the crankshaft, then remove the damper (Fig. 22).

INSTALLATION

1. Lubricate the crankshaft with an oil and white lead mixture and lubricate the oil seal rubbing surface with grease.

2. Align the damper keyway with the key on the crankshaft, and start the damper on the shaft. Press the damper on the shaft (Fig. 23). Install the lockwasher and capscrew, then tighten the capscrew to 85-95 foot-pounds torque. Install the pulley, spacer and fan. Install and adjust the drive belts. Install the radiator and fill and bleed the cooling system.

3. On B- and F-series trucks, install the grille to hood lock support bracket retaining bolt.

4. On P-series trucks, install the grille, headlamps, parking lamps, wind deflector, and hood lower weatherstrip. Install the hood.

CYLINDER FRONT COVER AND TIMING CHAIN

REMOVAL

1. Drain the cooling system and the crankcase. Remove the radiator, the crankshaft damper, and the oil pan. Remove the cylinder front cover retaining screws, then remove the cover and gasket.

2. Remove the crankshaft front oil slinger. Crank the engine until the timing marks are positioned as shown in Fig. 24. Remove the camshaft sprocket retaining bolt and washer.

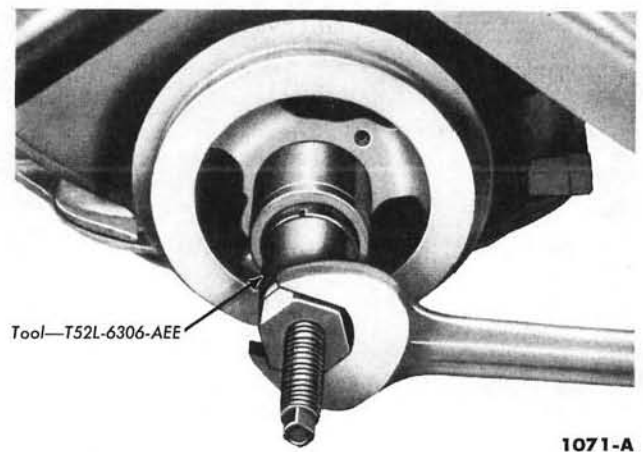

FIG. 23—Damper Installation

100% SATISFACTION GUARANTEED

BUY IT NOW!

Click Here To Order

PayPal American Express Discover MasterCard VISA

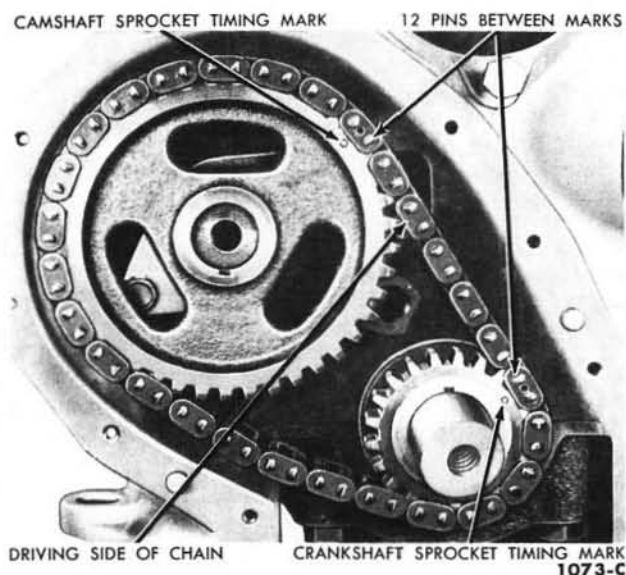

FIG. 24—Aligning Timing Marks

Slide both sprockets and the timing chain forward and remove them as an assembly.

Oil Seal Replacement. It is good practice to replace the oil seal each time the cylinder front cover is removed.

1. Drive out the old seal with a pin punch, then clean out the recess in the cover.

2. Coat a new seal with grease, then install the seal (Fig. 25). Drive the seal in until it is fully seated in the recess. Check the seal after installation to be sure the spring is properly positioned in the seal.

INSTALLATION

1. Place the keys in position in the slots on the crankshaft and camshaft.

2. Position the sprockets and timing chain on the camshaft and crankshaft. Be sure the timing marks on the sprockets and chain are positioned as shown in Fig. 24. There are 12 timing chain link pins between the timing marks on the sprockets.

3. Install the camshaft sprocket washer and retaining bolt. Tighten the bolt to 35-45 foot-pounds torque.

4. Rotate the crankshaft in a clockwise direction (as viewed from the front) to take up the slack on the left side of the chain. Establish a refer-

ence point on the left side of the chain out with the fingers and measure the distance between the reference point and the chain. The deflection is the difference between the two measurements. The deflection should not exceed $\frac{1}{2}$ inch.

5. Clean the cylinder front cover and the gasket surface of the cylinder block. Coat the gasket surface of the block and the cover with sealer, then position a new gasket on the block.

6. Place the cover on the block and install the retaining screws. Tighten the screws to 6-9 foot-pounds torque.

7. Install the oil pan, the crankshaft damper, and drive belt(s). Install the radiator. Fill and bleed the cooling system. Fill the crankcase with the proper grade and quantity of engine oil. Operate the engine at fast idle and check all hose connections and gaskets for leaks.

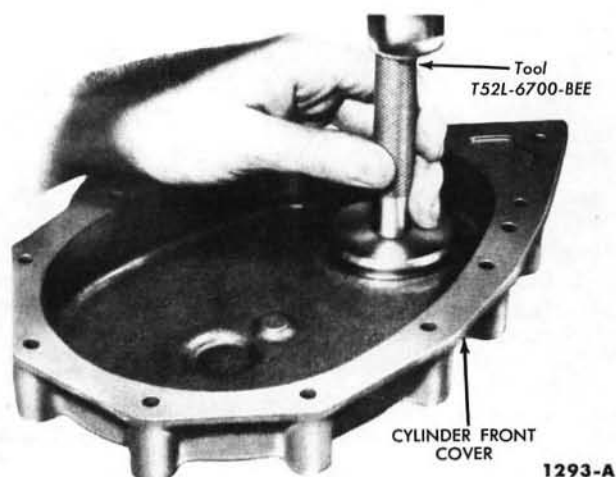
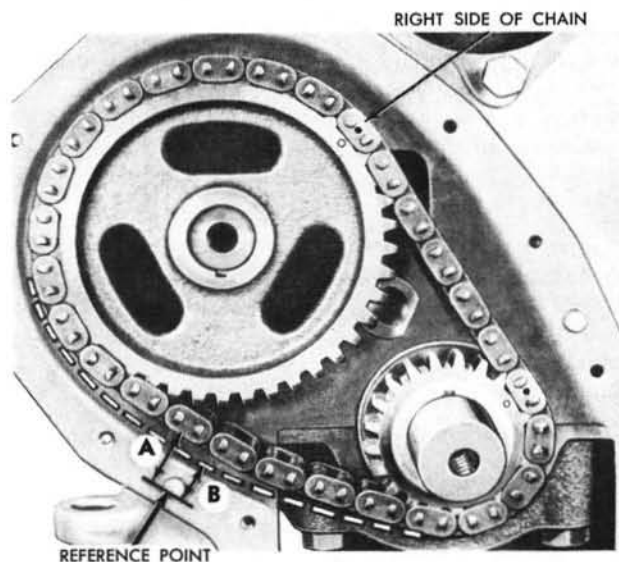

FIG. 25—Oil Seal Installation



TAKE UP SLACK ON LEFT SIDE. ESTABLISH A REFERENCE POINT AND MEASURE DISTANCE A. TAKE UP SLACK ON RIGHT SIDE AND FORCE LEFT SIDE OUT WITH THE FINGERS AND MEASURE DISTANCE B. DEFLECTION IS A MINUS B.

1398-A

FIG. 26—Timing Chain Deflection



BUY IT NOW!

Click Here To Order



6 CAMSHAFT, BEARINGS, AND TAPPETS

CAMSHAFT

The camshaft and related parts are shown in Fig. 27.

REMOVAL

1. Drain the cooling system and the crankcase. Remove the air cleaner and tape the carburetor air horn closed. Remove the radiator.

2. Disconnect the high tension wire from the coil and disconnect the spark plug wires, then remove the distributor cap and wiring as an assembly. Disconnect the distributor vacuum line and the primary wire at the distributor. Remove the oil level dip stick and the fuel pump. Disconnect the water temperature sending unit wire at the sending unit and remove the wire from the retaining clips, then remove the push rod chamber cover.

3. Remove the valve rocker arm cover, the valve rocker arm shaft assembly, and the valve push rods in sequence. Remove the fan, spacer, and pulley. Remove the crankshaft damper, cylinder front cover, and crankshaft oil slinger.

4. Crank the engine until the timing marks on the sprocket and chains are positioned as shown in Fig. 24. Scribe a line on the distributor housing and cylinder block to mark the position of the rotor and distributor housing for installation, then remove the distributor.

5. Remove the camshaft sprocket bolt and washer, the sprockets and timing chain, the camshaft thrust plate, the woodruff key, and spacer.

6. Turn the camshaft until the tappets can be lifted with either a magnet (Fig. 28) or the fingers. Raise the tappets clear of the camshaft lobes and secure them with spring-type clothes pins or window regulator spring clips (Figs. 28 and 29).

7. Remove the oil pan. Install the engine lifting hook and raise the engine enough to relieve the tension on the engine support brackets, then remove the engine right and left front support bracket to cylinder block retaining bolts. Lower the engine enough to facilitate camshaft removal and remove the camshaft by pulling it toward the front of the engine. Exercise caution to avoid damaging the camshaft bearings.

INSTALLATION

1. Oil the camshaft and carefully slide it through the bearings. Install the thrust plate and spacer. **Be sure the chamfer on the inside of the spacer is to the rear or faces the camshaft journal.** Install the woodruff key in the camshaft.

2. Raise the engine enough to align it with the engine front support brackets. Install the right and left support bracket retaining bolts. Remove the engine lifting hook.

3. Install the sprockets and timing chain. Be sure the timing marks are properly aligned. Install the sprocket washer and bolt, then tighten the bolt to 35-45 foot-pounds torque.

4. Install the crankshaft oil slinger, the cylinder front cover, crankshaft damper, pulley, spacer, and fan. Install and adjust the drive belt(s). Install the oil pan.

5. Release the tappets and install the push rods, then install the valve rocker arm shaft assembly. Perform a preliminary valve lash adjustment. Cement a new gasket to the valve push rod chamber and install

the cover. Connect the water temperature sending unit wire to the sending unit and install the wire in the retaining clip.

6. If the crankshaft was rotated, crank the engine until the No. 1 piston is on T.D.C., then position the distributor in the block with the rotor at the No. 1 firing position and the breaker points open. Connect the distributor vacuum line and primary wire. Install the distributor cap and connect the spark plug wires and the coil high tension wires. Install the fuel pump and the oil level dip stick.

7. Remove the tape from the air horn and install the air cleaner. Install the radiator.

BEARING REPLACEMENT

It will be necessary to remove the engine from the truck to replace camshaft bearings. The bearings are available pre-finished to size and require no reaming for standard and 0.015-inch undersize journal diameters. Number 3 bearing is not interchangeable with the other bearings.

1. Remove the engine from the chassis, then remove the camshaft. Drill a 1/2-inch hole in the center of the camshaft rear bearing bore plug and remove it as shown in Fig. 30. Remove the camshaft bearings (Fig. 31).

2. Position the bearing at the bearing bore and press it in place (Fig. 31). **Number 1 camshaft bearing must be pressed in 0.005-0.020 inch below the front face of the bearing bore. Press the remaining bearings in sufficiently to align the oil supply holes.**

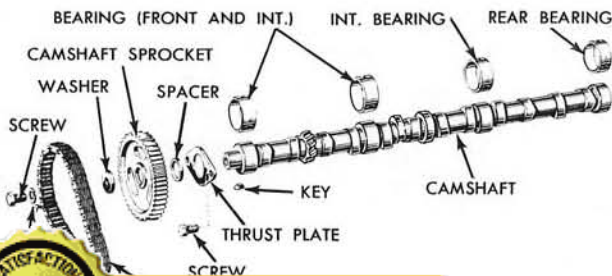

1074-C

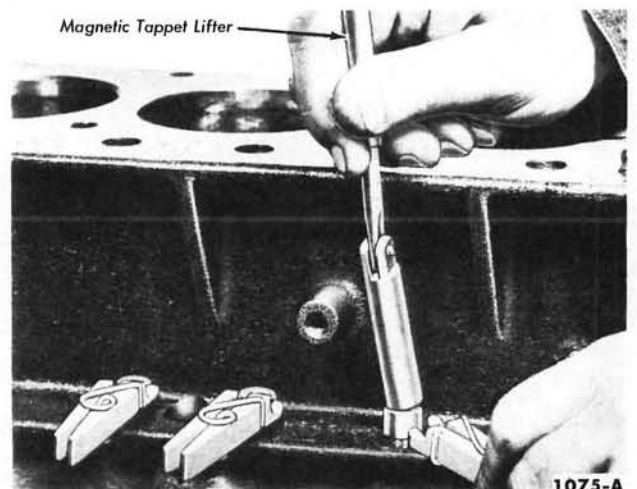

1075-A

FIG. 28—Lifting and Securing Valve Tappets

100% SATISFACTION GUARANTEED

BUY IT NOW!

Click Here To Order

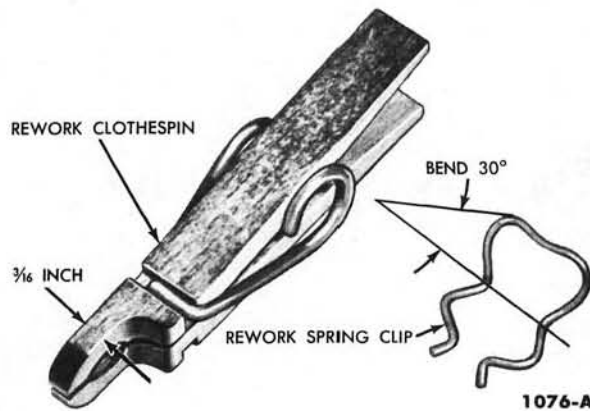

FIG. 29—Tappet Retainers

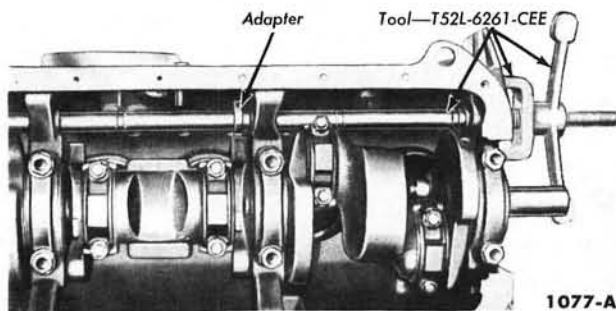

FIG. 31—Camshaft Bearing Replacement

3. Clean the camshaft rear bearing bore recess thoroughly. Coat the flange of a new plug with water resistant sealer and install it with the flange facing out (Fig. 32). Drive the plug in until the flange is flush or slightly below the casting surface. Install the camshaft and related parts. Install the engine in the chassis.

TAPPET REPLACEMENT

1. Remove the camshaft.

2. Remove and install one tappet at a time through the bottom of the block. A flexible-type holding tool can be used if desired. As each tap-

pet is installed, secure it in the up position.

3. After the tappets are installed, install the camshaft and related parts.

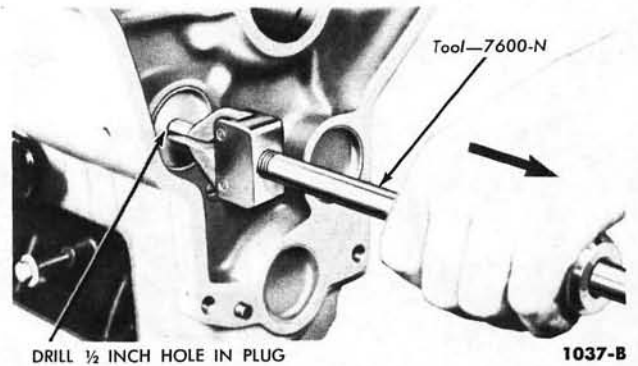

FIG. 30—Camshaft Rear Bearing Bore Plug Removal

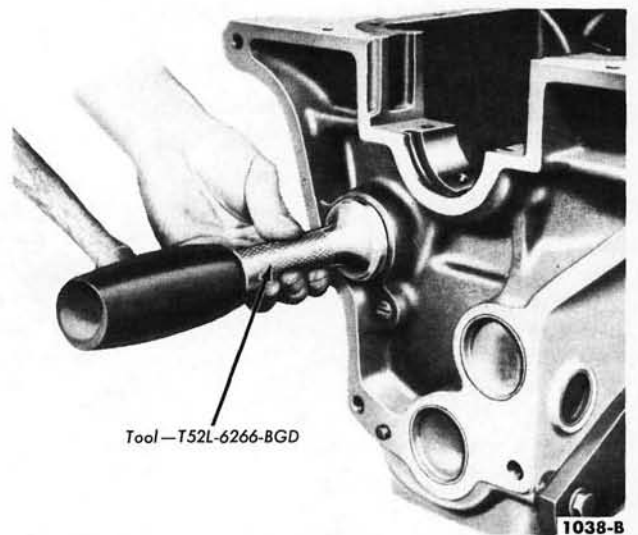

FIG. 32—Camshaft Rear Bearing Bore Plug Installation

7 FLYWHEEL, CRANKSHAFT, CONNECTING RODS, AND PISTON ASSEMBLIES

FLYWHEEL

The procedure for replacing the clutch pilot bushing is covered in Group 3—Part 1.

output shaft and install Tool 7657 in the transmission extension housing. Remove the speedometer cable from the transmission extension housing and secure it on the frame. Disconnect the gear shift rods from the transmission levers.

On overdrive transmissions, disconnect the governor and solenoid wires at the bullet connectors. Remove the wiring harness clip from the transmission. Disconnect the over-

drive manual control cable assembly.

2. Support the engine near the end of the oil pan, using a jack and a block of wood. Remove the transmission to flywheel housing retaining bolts and install pilots in the lower holes. Remove the flywheel housing cover. Slide the transmission far enough to the rear to clear the flywheel housing.

3. Remove the starter. Disconnect the clutch release lever retracting

CONVENTIONAL DRIVE OR OVERDRIVE
EQUIPPED TRUCKS

100% SATISFACTION GUARANTEED

BUY IT NOW!

Click Here To Order

PayPal American Express Cards Discover NOVUS MasterCard VISA

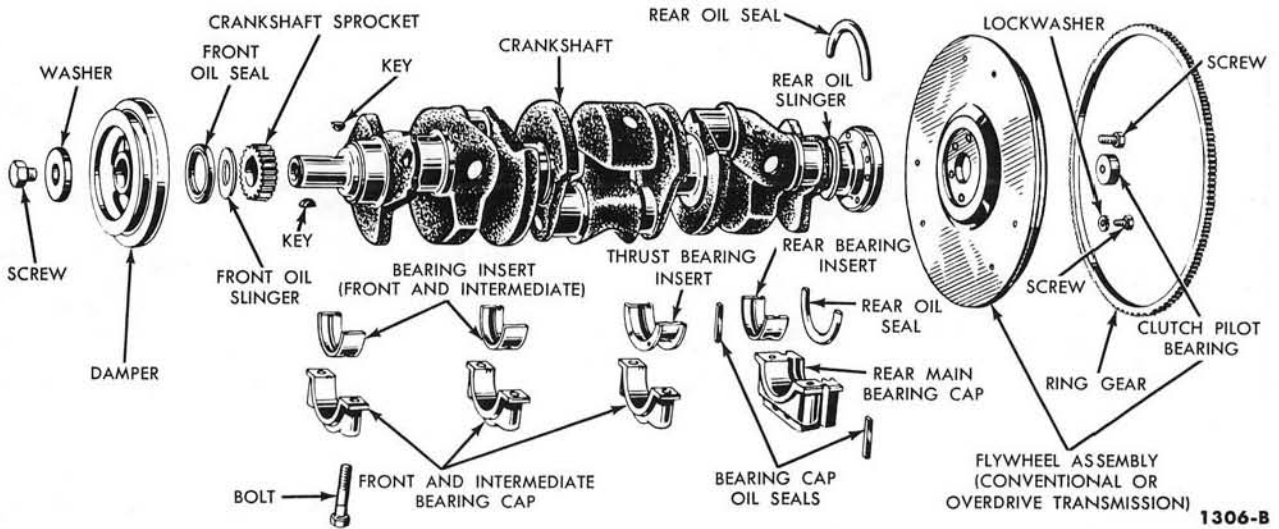

1306-B

FIG. 33—Crankshaft and Related Parts

spring, then slide the release bearing and hub off the release lever. Remove the clutch bracket to cylinder block bolts and disconnect the engine ground strap. Remove the flywheel housing retaining bolts and engine rear support bolts, then remove the flywheel housing.

4. Mark the pressure plate cover and flywheel to facilitate assembly, then loosen the cover to flywheel bolts evenly to release the pressure plate spring tension. Remove the cover, pressure plate, and disc. Remove the flywheel retaining bolts and remove the flywheel.

Ring Gear Replacement. Heat the defective ring gear with a blow torch on the engine side of the gear, then knock it off the flywheel. **Do not hit the flywheel when removing the ring gear.**

Heat the new ring gear evenly until the gear expands enough to slip onto the flywheel. Make sure the gear is seated properly against the shoulder. **Do not heat any portion of the gear to a temperature higher than 500° F. If this limit is exceeded, the temper will be removed from the ring gear teeth.**

75-85 foot-pounds torque. Position the clutch disc, pressure plate, and cover on the flywheel and start the cover bolts. Use Tool 7563-A or -N to align the clutch disc, then tighten the cover bolts to specifications.

2. Align the engine rear plate on the dowels and position the flywheel housing. Position the clutch release lever through the slot in the housing. Install the flywheel housing bolts and tighten them to specifications.

3. Connect the engine ground strap and the clutch bracket. Install the release bearing and hub. Connect the clutch retracting spring. Install the starter and connect the starter cable.

4. Slide the transmission forward on the pilots and install the transmission to flywheel housing upper bolts. Remove the pilot studs and install the lower retaining bolts. Remove the jack supporting the engine. Connect the gear shift rods and install the speedometer cable. Adjust the clutch pedal free travel (Group 3—Part 1). Install the flywheel housing cover.

5. Remove the tool from the transmission extension housing and install the drive shaft.

On overdrive transmissions, connect the governor and solenoid wires at the bullet connectors. Install the wiring harness clip on the transmission. Connect the overdrive manual control cable assembly.

TRUCKS WITH AN AUTOMATIC TRANSMISSION

Removal

1. Disconnect the automatic transmission fluid filler tube and drain the transmission. Remove the converter housing cover assembly. Disconnect the drive shaft at the rear universal joint flange. Slide the drive shaft off the transmission output shaft and install Tool 7657 in the transmission extension housing. Remove the converter drain plugs and allow the fluid to drain from the converter, then install the drain plugs. Disconnect the parking brake rear cable at the equalizer yoke. Support the engine near the end of the oil pan, using a jack and a block of wood. Remove the converter to flywheel housing bolts.

2. Remove the starter and the transmission filler tube bracket.

3. Disconnect the speedometer cable and transmission gear shift rods. Support the transmission, then remove the converter housing bolts and engine rear support bolts, then slide the transmission and converter housing to the rear. Remove the flywheel retaining bolts and remove the flywheel.

Installation

1. Position the flywheel on the crankshaft and install the retaining bolts. Tighten the bolts to 75-85 foot-

Installation

Position the flywheel on the

100% SATISFACTION GUARANTEED

BUY IT NOW!

Click Here To Order

PayPal

Discover Cards

Discover Novus

MasterCard

VISA

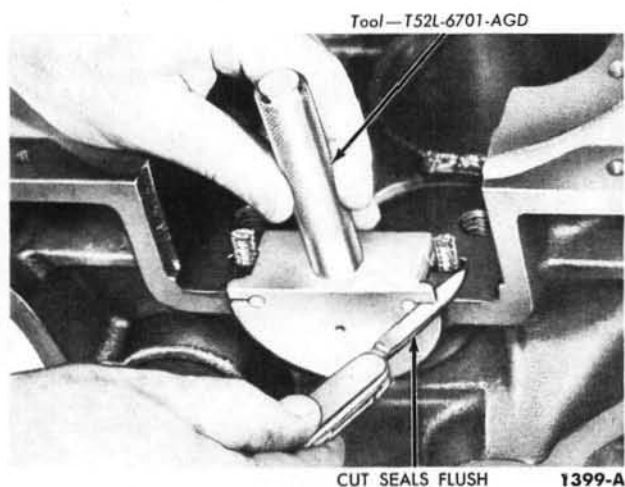

FIG. 34—Rear Oil Seal To Block Installation

pounds torque. Position the converter housing and transmission and install the converter nuts and bolts. Install the converter housing bolts. Remove the transmission jack.

2. Install the starter and the automatic transmission fluid filler tube bracket. Connect the starter cable.

3. Connect the speedometer cable and the transmission gear shift rods. Install the engine rear support bolts and nuts and tighten them to specifications. Connect the automatic transmission fluid filler tube and the parking brake rear cable. Remove the tool from the transmission extension housing and install the drive shaft. Install the converter housing cover assembly.

4. Fill the transmission with Automatic Transmission Fluid—Type A. Adjust the automatic transmission throttle linkage.

CRANKSHAFT

The crankshaft and related parts are shown in Fig. 33.

REMOVAL

1. Drain the cooling system and the crankcase. Remove the engine from the chassis and install it on a work stand. Remove the distributor, level dip stick, water pump, generator, crankshaft damper, cylinder

and the oil pump.

2. Make sure all bearing caps (main and connecting rod) are marked so they can be installed in their original locations. Remove the connecting rod bearing caps, using care not to intermix the caps, then push the pistons to the top of the cylinders. Remove the main bearing caps.

3. Carefully lift the crankshaft out of the block so the thrust bearing surfaces are not damaged. Remove the rear journal oil seal from the block and rear bearing cap, and remove the cap to block side seals.

4. If new main and/or connecting rod bearings are to be installed, remove the main bearing inserts from the block and the bearing caps, and/or the connecting rod bearing inserts from the connecting rod and cap. Install new bearings following the procedure in Section 8—"Main and Connecting Rod Bearing Replacement."

INSTALLATION

1. Be sure the bearings, crankshaft journals, and the rear journal oil seal grooves are clean. Install a new rear oil seal in the cylinder block (Fig. 34), and in the rear main bearing cap (Fig. 35). After installation, cut the ends of the seals flush.

2. Carefully lower the crankshaft

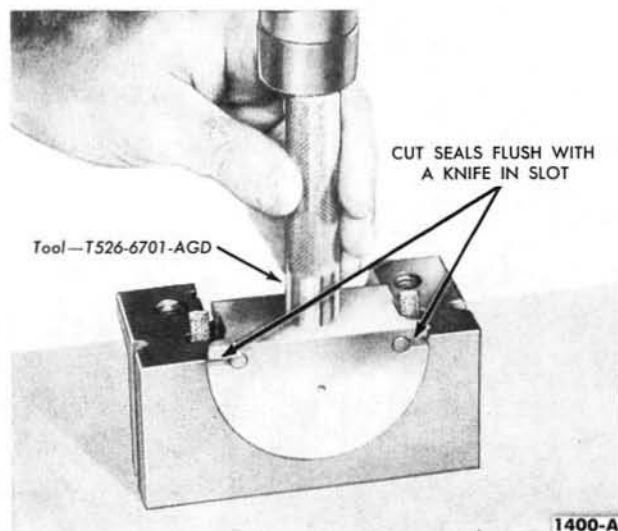

FIG. 35—Rear Oil Seal To Rear Bearing Cap Installation

into place. **Be careful not to damage the bearing surfaces.**

3. Check the clearance of each main bearing following the procedure under "Main Bearing Replacement" in Section 8. If the bearing clearances are satisfactory, apply a light coat of engine oil to the journals and bearings, then install all the bearing caps except the thrust bearing cap (No. 3 bearing). Tighten the bearing cap bolts to 95-105 foot-pounds torque. Dip the rear bearing cap side seals in light engine oil, then immediately install them in the grooves. **Do not use sealer on the side seals. The seals are designed to expand when dipped in oil. Using sealer may retard this expansion.** It may be necessary to tap the seals into place for the last 1/2 inch of travel. Do not cut the seal projecting ends. Check the side seals for leaks by squirting a few drops of oil into the parting lines between the rear bearing cap and the cylinder block from the outside. Blow compressed air against the seals from the inside of the block. If air bubbles appear in the oil, it indicates possible oil leakage. **The above test should not be performed on newly installed seals until sufficient time has been allowed for the seals to expand into the seal grooves.**

4. Install the thrust bearing cap with the bolts finger tight, then pry the crankshaft forward against the



BUY IT NOW!

Click Here To Order



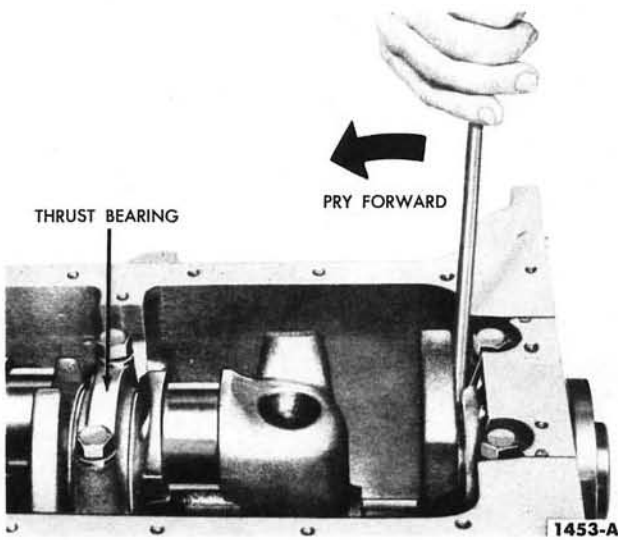

FIG. 36—Thrust Bearing Alignment—Pry Crankshaft Forward

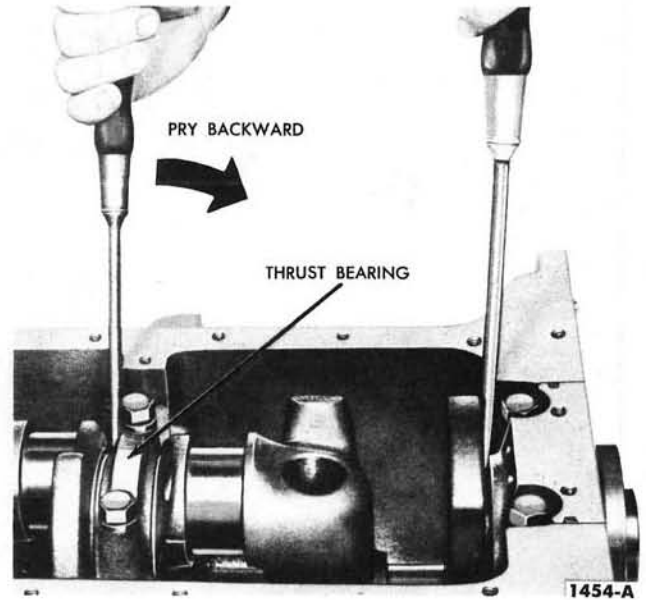

FIG. 37—Thrust Bearing Alignment—Pry Cap Backward

thrust surface of the upper half of the bearing (Fig. 36). Hold the crankshaft forward and pry the thrust bearing cap to the rear (Fig. 37). This will align the thrust surfaces of both halves of the bearing. Retain the forward pressure on the crankshaft and tighten the cap bolts to 95-105 foot-pounds torque (Fig. 38).

5. Force the crankshaft toward the rear of the engine. Install a dial indicator so the contact point rests against the crankshaft flange and the indicator axis is parallel to the crankshaft axis (Fig. 39). Set the dial on zero, then push the crankshaft forward and note the reading on the dial.

If the end play exceeds the wear limit, replace the thrust bearing. If the end play is less than the minimum limit, inspect the thrust bearing faces for scratches, burrs, nicks, or dirt. If the thrust faces are not defective or dirty, they probably were not aligned properly. Install the thrust bearing and align the faces following the recommended procedure, then recheck the end play.

6. Check the clearance of each connecting rod bearing following the procedure under "Connecting Rod Bearing Replacement" in Section 8. Bearing clearances are satisfac-

Install the pal nuts and tighten them to 3-4 foot-pounds torque. Check the side clearance between the connecting rods on each crankpin following the procedure under "Piston and Connecting Rod Installation."

7. Install the flywheel, oil pump, oil pump screen and inlet tube assembly, crankshaft damper key, and the oil pan.

8. Install the sprockets and timing chain with the timing marks aligned (Fig. 24). Install the crankshaft front oil slinger, cylinder front cover, and the crankshaft damper. Install the water pump, distributor, crankcase ventilation tube, oil level dip stick, pulley, and fan. Install the generator, then install and adjust the drive belt.

9. Install the engine in the chassis. Fill and bleed the cooling system. Fill the crankcase with the proper grade and quantity of engine oil. Start the engine and check and adjust the ignition timing. Operate the engine at fast idle and check for oil pressure and check all hose connections and gaskets for leaks.

PISTON AND CONNECTING ROD REMOVAL

The piston and connecting rod assembly is shown in Fig. 40.

1. Drain the cooling system and the crankcase. Remove the air cleaner, then tape the air horn closed. Remove the cylinder head, oil level dip stick, crankcase ventilation tube, flywheel housing inspection cover, oil pan, and the oil pump screen and inlet tube.

2. Before removing the piston assemblies, remove any ridge and/or deposits from the upper end of the cylinder bores. Move the piston to the bottom of its travel and place a cloth on the piston head to collect the cuttings. Remove the cylinder ridge with a ridge cutter. **Never cut into the ring travel area in excess of 1/32 inch when removing ridges.** After the ridge has been removed, remove the cutter from the cylinder bore, then turn the crankshaft until the piston is at the top of its stroke and carefully remove the cloth with the cuttings.

3. Turn the crankshaft until the connecting rod being removed is down. Remove the pal nuts and the hex head nuts from the connecting rod bolts. Pull the cap off the rod, then push the rod and piston assembly out the top of the cylinder with the handle end of a hammer. **Avoid damage to the crankpin or the cylinder wall when removing the piston.**

100% SATISFACTION GUARANTEED

BUY IT NOW!

Click Here To Order

PayPal American Express DISCOVER NOVUS MasterCard VISA

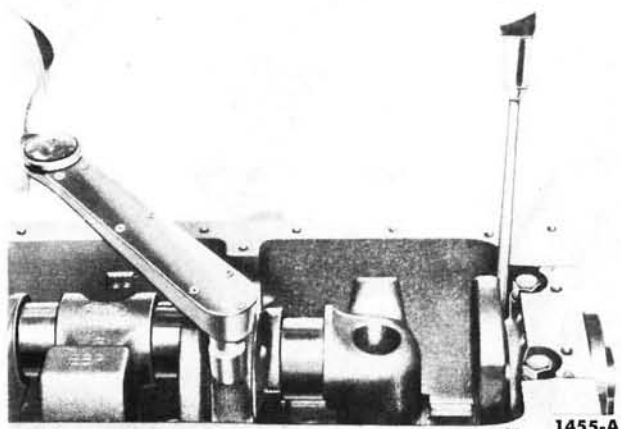

FIG. 38—Thrust Bearing Alignment—Tighten Cap

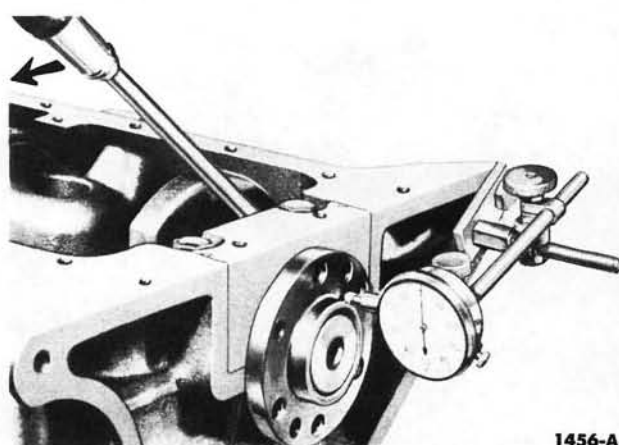

FIG. 39—Crankshaft End Play

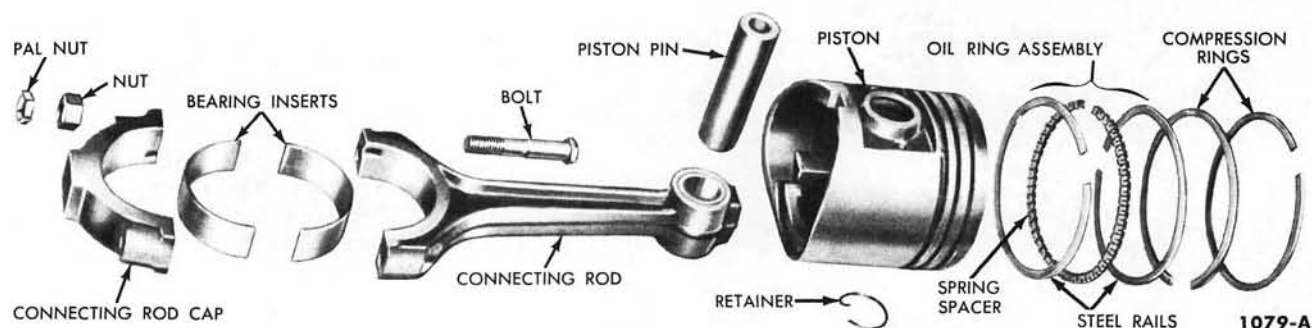

FIG. 40—Piston and Connecting Rod Assembly



1080-B

4. If new piston rings are to be installed and the cylinder has not been refinished, remove the glaze from the cylinder wall by passing a fine grit hone or glaze removal tool through the bore a few times. **Take all the necessary precautions to catch the grit.** Do not hone more than enough to rough up the finish. Thoroughly clean the cylinder walls and the block after the glaze is removed, then oil the walls.

5. Repeat the above procedure on each assembly.

PISTON AND CONNECTING ROD DISASSEMBLY

Mark the pistons and pins to assure assembly with the same rod and installation in the same cylinder from which they were removed. Remove the piston rings. Remove the piston pin retainers, then drive the pin out of the piston and rod (Fig. 41). Discard the retainers.



BUY IT NOW!

Click Here To Order



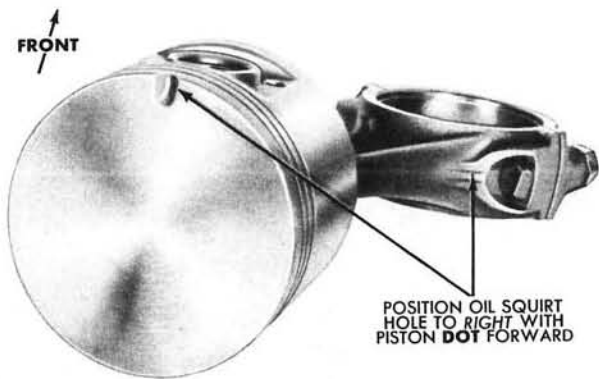

1081-A

FIG. 42—Correct Position of Oil Squirt Hole



FIG. 43—Piston Ring Side Clearance

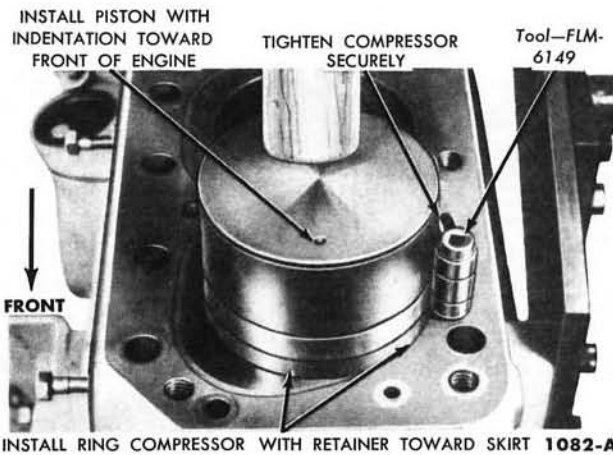

FIG. 44—Piston Installation

PISTON AND CONNECTING ROD ASSEMBLY

1. Lubricate all parts with light engine oil. Position the connecting rod in the piston and push the pin into place. Assemble the piston and connecting rod with the oil squirt hole in the rod positioned as shown in Fig. 42.

2. Insert new piston pin retainers by spiraling them into position with the fingers. Do not use pliers. Follow the instructions contained on the piston ring package and install the piston rings.

3. Check the ring side clearance of the compression rings with a feeler gauge inserted between the ring and the cylinder wall (Fig. 43). The gauge

at the inner portion of the lower land. If the lower lands have high steps, the piston should be replaced.

4. Be sure the bearings and journals are clean. If it is necessary to replace the connecting rod bearings, replace them at this time following the procedure under "Connecting Rod Bearing Replacement" in Section 8.

PISTON AND CONNECTING ROD INSTALLATION

Be sure to install the pistons in the same cylinder from which they were removed, or to which they were fitted. Each connecting rod and bearing cap is numbered from 1 to 6 beginning at the front of the engine. The numbers on the connecting rod and bearing cap must be on the same side when installed in the cylinder bore.

If a connecting rod is ever transposed from one block or cylinder to another, new bearings should be fitted, and the rod should be numbered to correspond with the new cylinder number.

1. Oil the piston rings, pistons, and cylinder walls with light engine oil.

2. Make sure the ring gaps are properly spaced around the circumference of the piston. Install a piston ring compressor on the piston and push the piston in with the handle end of a hammer until it is slightly below the top of the cylinder (Fig. 44). Be sure to guide the connecting rods to avoid damaging the crankshaft journals. Install the piston with the indentation in the piston head toward the front of the engine.

3. Check the clearance of each bearing following the procedure under "Connecting Rod Bearing Replacement" in Section 8. If the bearing clearances are to specifications, apply a light coat of engine oil to the journals and bearings.

4. Turn the crankshaft throw to the bottom of its stroke, then push the piston all the way down until the connecting rod bearing seats on the crankshaft journal. Install the connecting rod cap, then tighten the nuts to 45-50 foot-pounds torque. Install the pal nuts and tighten them to 3-4 foot-pounds torque.

100% SATISFACTION GUARANTEED

BUY IT NOW!

Click Here To Order

PayPal American Express Discover MasterCard VISA

5. After all the piston and connecting rod assemblies have been installed, check the side clearance between the connecting rods on each crankshaft journal (Fig. 45).

6. Install the oil pump screen and inlet tube, oil pan, flywheel housing inspection cover, crankcase ventilation tube, oil level dip stick, and the cylinder head and related parts. Make a preliminary valve lash adjustment. Fill and bleed the cooling system and fill the crankcase.

7. Start the engine and operate it for a minimum of 30 minutes at approximately 1200 rpm. Check the valve lash with the engine idling and adjust it if necessary. Make sure there is sufficient oil pressure and the engine does not overheat. Check for oil and coolant leaks. Install the valve rocker arm cover and the air cleaner.

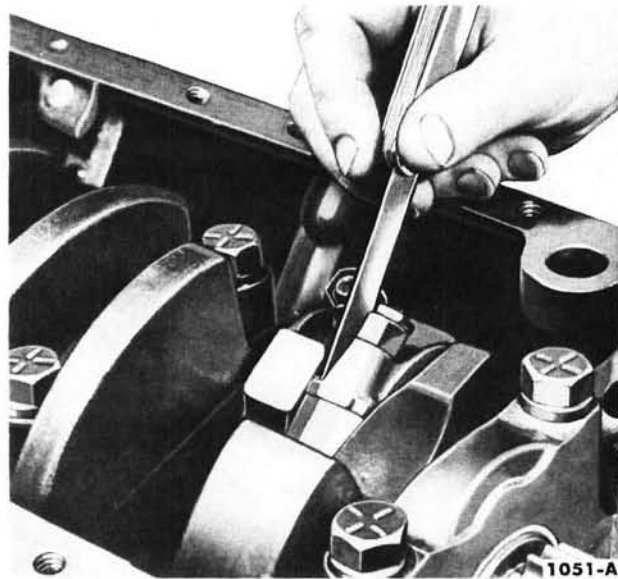

FIG. 45—Connecting Rod Side Clearance

8 MAIN AND CONNECTING ROD BEARING REPLACEMENT

The main and connecting rod bearing inserts are selective fit and do not require reaming to size upon installation. **Do not file or lap bearing caps or use shims to obtain the proper bearing clearance.**

Selective fit bearings are available for service in standard sizes only. Standard bearings are divided into two sizes and are identified by a daub of red or blue paint. **Red marked bearings increase the clearance; blue marked bearings decrease the clearance.** Undersize bearings, which are not selective fit, are available for use on journals that have been refinished.

Normally, main bearing journals wear evenly and are not out-of-round. However, if a bearing is being fitted to an out-of-round journal, be sure to fit the bearing to the maximum diameter of the journal. If the bearing is fitted to the minimum diameter with minimum clearance, interference may result, causing an early failure. It is not recommended that bearings be fitted to a crankshaft journal which exceeds the maximum out-of-round specification. **When re-**

dirt may distort the bearing and cause bearing failure.

MAIN BEARING REPLACEMENT

The following procedure is for the engine installed in the chassis. If the engine is on a work stand follow steps 2-5. In step 4 it is not necessary to support the crankshaft because the engine will be inverted. Also place the Plastigage on the crankshaft journal instead of on the bearing surface (Fig. 46) if the engine is on a work stand.

1. Drain the crankcase. Remove the distributor, oil level dip stick, crankcase ventilation tube, flywheel housing inspection cover, oil pan, and the oil pump.

2. **Replace one bearing at a time, leaving the other bearings securely fastened.** Remove the main bearing cap to which new bearings are to be fitted. Insert the upper bearing removal tool (Tool 6331) in the oil hole in the crankshaft. Rotate the crankshaft in the direction of engine rotation to force the bearing out of the block.

3. To install the upper main bearing, place the plain end of the bearing over the shaft on the locking tang side of the block. Insert Tool 6331 in the oil hole in the crankshaft and rotate the crankshaft in the opposite direction of engine rotation until the bearing seats itself. Remove the tool. Replace the cap bearing. Clean the crankshaft journal and bearings.

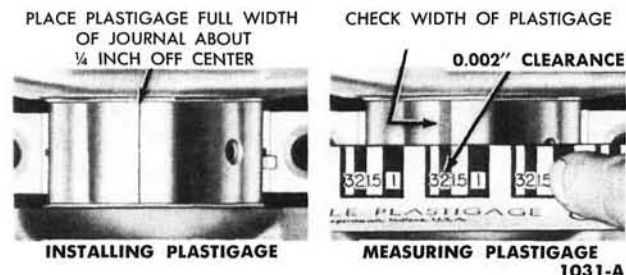

FIG. 46—Installing and Measuring Plastigage—Engine on Work Stand

100% SATISFACTION GUARANTEED

BUY IT NOW!

Click Here To Order

PayPal American Express Discover MasterCard VISA

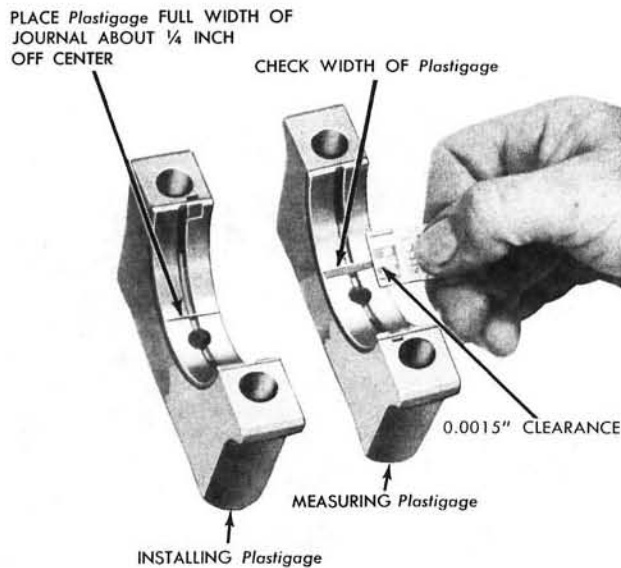

1558-B

FIG. 47—Installing and Measuring Plastigage—Engine in Chassis

4. Support the crankshaft so its weight will not compress the Plastigage and provide an erroneous reading. Position a small jack so it will bear against the counterweight adjoining the bearing which is being checked. Place a piece of Plastigage on the bearing surface (Fig. 47) the full width of the bearing cap and tighten the bolts to 95-105 foot-pounds torque. **Do not turn the crankshaft while the Plastigage is in place.** Remove the cap, then using the Plastigage scale, check the width of the Plastigage (Fig. 47) at the widest point in order to get the minimum clearance. Check the Plastigage at the narrowest point in order to get the maximum clearance. The difference between the two readings is the taper.

If the clearance is less than the specified limits, try two red bearing halves or a combination of red and blue depending upon the condition. If the standard bearings do not bring the clearance within the desired limits, refinish the crankshaft journal. If the clearance has been

95-105 foot-pounds torque.

6. If the rear main bearing is replaced, replace the lower oil seal (in the cap) and the side seals. The upper oil seal can not be replaced unless the crankshaft is removed from the engine.

7. Install the oil pump, oil pump screen and inlet tube assembly, oil pan, flywheel housing inspection cover, crankcase ventilation tube, and oil level dip stick. Crank the engine until the No. 1 piston is on T.D.C., then position the distributor in the block with the rotor at the No. 1 firing position and the breaker points open. Install the distributor hold down clamp. Fill the crankcase.

8. Start the engine and check and adjust the ignition timing. Operate the engine at fast idle and check for oil pressure and oil leaks.

CONNECTING ROD BEARING REPLACEMENT

1. Drain the crankcase. Remove the oil level dip stick, distributor, crankcase ventilation tube, flywheel housing inspection cover, oil pan, and oil pump screen and inlet tube. Remove the cap from the connecting rod to which new bearings are to be installed and remove the bearing in-

sert. Push the piston up in the cylinder, then remove the bearing insert from the connecting rod. Clean the crankshaft journal, the cap, and the upper half of the bearing bore.

2. Install the new bearings in the connecting rod and cap.

Pull the connecting rod assembly down firmly on the crankshaft journal. Place a piece of Plastigage on the lower bearing surface, the full width of the cap and about 1/4 inch off center. Install the cap and tighten the connecting rod nuts to 45-50 foot-pounds torque. **Do not turn the crankshaft while the Plastigage is in place.**

3. Remove the cap, then using the Plastigage scale check the width of the Plastigage at the widest point in order to get the minimum clearance. Check the Plastigage at the narrowest point in order to get the maximum clearance. The difference between the two readings is the taper.

If the clearance is less than the specified limits, try two red bearing halves or a combination of red and blue depending upon the condition. If the standard bearings do not bring the clearance within the desired limits, refinish the crankshaft journal, then install undersize bearings.

After the bearing clearance has been checked and found to be satisfactory, apply a light coat of engine oil to the crankshaft journal and bearings, then install the connecting rod cap. Tighten the nuts to 45-50 foot-pounds torque, then install the pal nuts and tighten them to 3-4 foot-pounds torque.

4. Repeat the procedure for the remaining connecting rods that require new bearings.

5. After all the bearings that required replacement have been replaced, install the oil pump screen and inlet tube, oil pan, flywheel housing inspection cover, crankcase ventilation tube, and oil level dip stick. Crank the engine until the No. 1 piston is on T.D.C., then position the distributor in the block with the rotor at the No. 1 firing position and the breaker points open. Install the distributor hold down clamp. Fill the crankcase, then operate the engine and check for oil pressure and oil leaks.

100% SATISFACTION GUARANTEED

BUY IT NOW!

Click Here To Order

PayPal American Express Discover Novus MasterCard VISA

9 OIL PAN, OIL PUMP, AND OIL FILTER

OIL PAN

REMOVAL

Drain the crankcase. Remove the oil level dip stick and the flywheel housing cover. Remove the oil pan retaining screws and remove the pan and gasket.

INSTALLATION

1. Make sure the gasket surfaces of the block and oil pan are clean and free from burrs. Coat the block surface and oil pan gasket surface with sealer and position the gasket on the oil pan.

2. Hold the oil pan in place against the block and install a screw, finger tight, on each side of the oil pan near the center. Install the remaining screws, then tighten the screws from the center outward in each direction to 12-15 foot-pounds torque.

3. Install the flywheel housing cover and the oil level dip stick.

4. Fill the crankcase with the proper grade and quantity of engine oil. Operate the engine and check for oil leaks.

OIL PUMP

The oil pump is shown in Fig. 48.

REMOVAL

1. Remove the distributor, oil level dip stick, and the oil pan.

2. Remove the two nuts and lockwashers retaining the oil pump to the cylinder block, then remove the pump and gasket.

3. Thoroughly clean the old gasket material from the mounting pad on the block and pump.

DISASSEMBLY

1. Remove the oil pump cover, inlet tube assembly and gaskets from the oil pump. Remove the snap wire retaining the screen in the inlet tube assembly and remove the screen.

2. Push the oil pump drive shaft and drive gear assembly from the pump housing. Remove the driven gear.

3. Remove the oil pressure relief valve chamber plug, spring, and plunger.

ASSEMBLY

1. Apply a light coat of engine oil to all moving parts.

2. Install the pressure relief valve plunger, spring, and plug. Tighten the plug to 33-38 foot-pounds torque.

3. Slide the drive gear and shaft assembly into the housing. Install the driven gear. Check the end play of the gears (Group 1—Part 1).

4. Apply sealer to both sides of the oil pump cover gasket, then position the gasket on the oil pump. In-

stall the oil pump cover.

5. Install the screen in the inlet tube assembly and secure it with the snap wire.

6. Install the inlet tube gasket, and the inlet tube assembly on the oil pump cover. Tighten the retaining screws to 12-15 foot-pounds torque. Rotate the pump shaft by hand to make sure it turns freely.

INSTALLATION

1. Place a new gasket on the retaining bolts, slide the pump mounting flange over the retaining bolts, and install the lockwashers and nuts. Tighten the nuts to 30-35 foot-pounds torque. Install the distributor and the oil pan and related parts.

2. Fill the crankcase and operate the engine at fast idle and check for oil pressure and oil leaks.

OIL FILTER REPLACEMENT

REMOVAL

Place a drip pan under the filter. Remove the filter center bolt, then remove the filter assembly and gasket.

DISASSEMBLY

1. Remove the filter element, neoprene gasket, spring and seat, then remove the center bolt from the container and the fiber gasket from the bolt (Fig. 49).

2. Discard the filter element and all gaskets. Wash all parts in solvent. Make sure all openings in the center bolt are clean.

ASSEMBLY

1. Install a new fiber gasket on the center bolt, then place the bolt through the filter container.

2. Install the spring and spring seat assembly on the bolt, making sure the seat tangs are engaged in the spring.

3. Install a new neoprene gasket and new filter element over the center bolt.

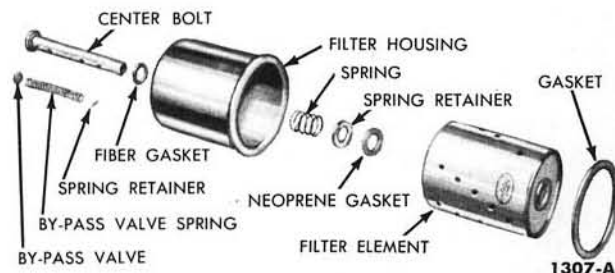
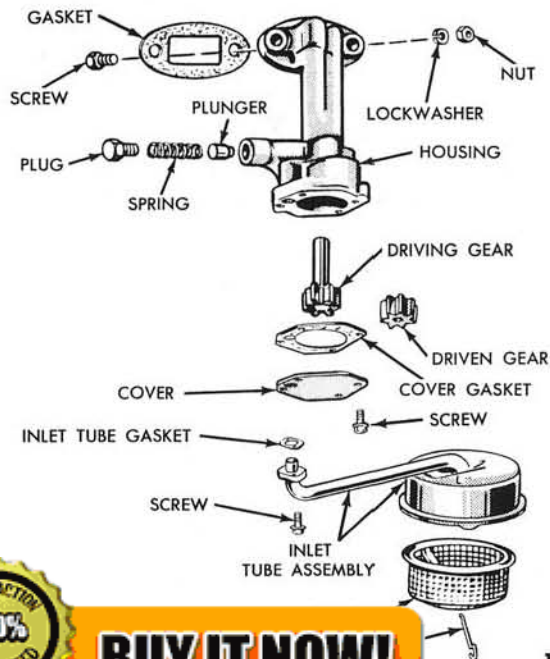

FIG. 49—Oil Filter Disassembled

100% SATISFACTION GUARANTEED

BUY IT NOW!

Click Here To Order

PayPal American Express Discover MasterCard VISA

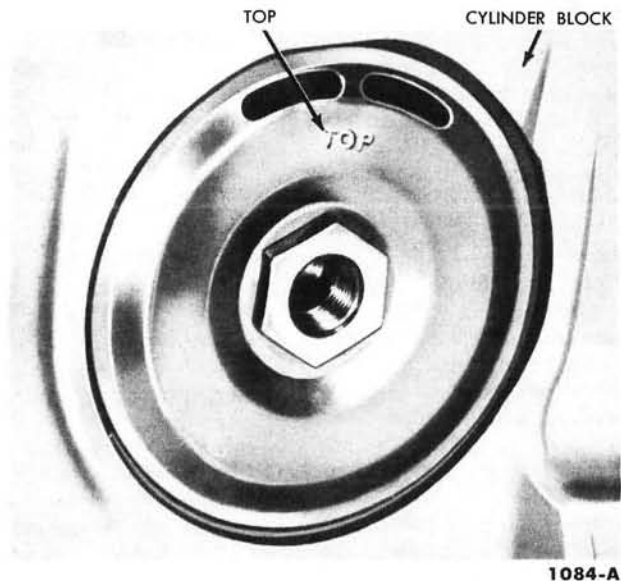

FIG. 50—Anti-Drain Back Diaphragm Position

INSTALLATION

1. Make sure the two elongated holes in the oil filter anti-drain back diaphragm are in the up position (Fig. 50).

2. Clean the cylinder block filter recess, then install a new gasket.

3. Place the filter assembly in position, and thread the center bolt into the adapter finger-tight. Rotate the filter assembly slightly, in each direction, to make sure the gasket is seated evenly. Tighten the center bolt to 20-25 foot-pounds torque. **Do not over tighten the center bolt.**

4. Refill the crankcase with oil if necessary, then operate the engine at fast idle and check for oil leaks. If oil leaks are evident, perform the necessary repairs to correct the leakage.

10 EXHAUST SYSTEM

The exhaust system consists of a muffler and inlet pipe assembly, and a muffler outlet pipe. The muffler and inlet pipe assembly are used in production only. A separate muffler and inlet pipe are used for service replacement. **When replacing any part of the exhaust system, loosen all the frame attaching bracket clamps to relieve twists in the system, then tighten the clamps.**

INLET PIPE AND MUFFLER REPLACEMENT

1. Loosen all outlet pipe clamps,

then slide the outlet pipe to the rear.

2. Remove the inlet pipe to manifold retaining nuts, then remove the inlet pipe and muffler assembly. Remove the gasket from the exhaust manifold.

3. Position a new service inlet pipe on the exhaust manifold using a new gasket. Install the retaining nuts, then tighten the nuts to 23-28 foot-pounds torque.

4. Place the muffler clamp on the inlet pipe, then position a new muffler on the inlet pipe. Install and tighten the clamp. Slide the outlet pipe into

the muffler and tighten the outlet pipe to muffler clamp. Tighten the outlet pipe support clamps.

OUTLET PIPE REPLACEMENT

1. Loosen the outlet pipe clamp at the muffler. Remove the outlet pipe support clamps, then pull the outlet pipe off the muffler.

2. Position the muffler clamp on the new outlet pipe, then slide the pipe on the muffler. Install, but do not tighten the support clamps. Tighten the outlet pipe to muffler clamp, then tighten the support clamps.

100% SATISFACTION GUARANTEED

BUY IT NOW!

Click Here To Order

**PART 3
MEDIUM AND HEAVY
DUTY V-8 ENGINES**

Section	Page
1 Description	1-43
2 Engine Removal and Installation	1-47
3 Engine Supports	1-50
4 Manifolds, Cylinder Heads, and Valves	1-51
5 Crankshaft Damper, Cylinder Front Cover, and Timing Chain and Gears.....	1-57
6 Camshaft, Bearings, and Tappets	1-60
7 Flywheel, Crankshaft, Connecting Rods, and Piston Assemblies	1-64
8 Main and Connecting Rod Bearing Replacement	1-70

9 Oil Pan, Oil Pump, and Oil Filter	1-72
10 Exhaust System	1-73

The medium duty V-8 engines (272 and 292 cubic inch displacement) will be referred to as MD V-8 engines and the heavy duty V-8 engines (272, 292, 302, and 332 cubic inch displacement) will be referred to as HD V-8 engines.

The service procedures given here are for the engine installed in the chassis unless otherwise noted. Cleaning, inspection, repair, and overhaul procedures are covered in Part 1, "General Engine Service."

1 DESCRIPTION

The MD and HD V-8 engines (Figs. 1, 2, and 3) have the same basic design. The differences between the engine models and their application are listed in Table 1.

MANIFOLDS

The intake manifold contains a passage through the center section and under the carburetor, through which hot exhaust gases are directed to assist in vaporizing the incoming fuel charge.

On the MD V-8 engines, the exhaust gases are directed into the intake manifold by a thermostatically controlled exhaust valve. The valve is located between the crossover pipe and the inlet of the right exhaust

manifold. When the valve is closed or in the "heat on" position part of the exhaust gases are directed from the left exhaust manifold, through the heat riser passage, to the right exhaust manifold (Fig. 4). When the valve opens "heat off," more of the exhaust gases from the left manifold are permitted to flow directly out the exhaust system in the normal manner.

An exhaust gas control valve is not used on the HD V-8 engines.

The intake manifold has two sets of fuel passages, each with its own separate inlet connection to the carburetor (Fig. 5). The right barrel(s) of the carburetor feeds Nos. 2, 3, 5, and 8 cylinders, and the left barrel(s) feeds Nos. 1, 4, 6, and 7 cylinders.

Some 272 and 292 HD V-8 engines and all 302 and 332 HD V-8 engines have ram's horn-type exhaust manifolds. The exhaust manifolds are interchangeable between engines and between either side of the engine.

The 272 and 292 MD and HD V-8 engines use the conventional-type exhaust manifold (ram's horn exhaust manifolds are used on the HD V-8 engines used in C-Series trucks).

CYLINDER HEADS AND BLOCK

The cylinders are numbered from front to rear on the right bank 1, 2, 3, and 4 and on the left bank 5, 6, 7, and 8. The firing order is 1-5-4-8-6-3-7-2. The valves are arranged from

TABLE 1—Engine Model Application

Patent Plate Code	Engine	Cubic Inch Displ.	Comp. Ratio	Carb.	Gov.	Dist.	Truck Model Application
L	Medium Duty V-8	272	8.3:1	2-Barrel	Velocity*	Dual Advance	C-550, 600; B-C-F-T-700; P series; F-100 thru 600; B-500, 600*
C	Medium Duty V-8	292	7.9:1	2-Barrel	Velocity*	Dual Advance	C-550, 600; B-C-F-T-700; P series; F-100 thru 600; B-500, 600*
U	Heavy Duty V-8	272	7.6:1	4-Barrel	Vacuum	Loadomatic	F-B-C-T-700, C-550, 600*
D	Heavy Duty V-8	292	7.6:1	4-Barrel	Vacuum	Centrifugal Advance	F-B-C-T-700; C-550, 600*
N	Heavy Duty V-8	302	7.5:1	4-Barrel	Vacuum	Centrifugal Advance	B-C-F-750; T-700*
		332	7.5:1	4-Barrel	Vacuum	Centrifugal Advance	T-750; C-F-T-800; C-F-900

100% SATISFACTION GUARANTEED

BUY IT NOW!

Click Here To Order

PayPal American Express Discover MasterCard VISA

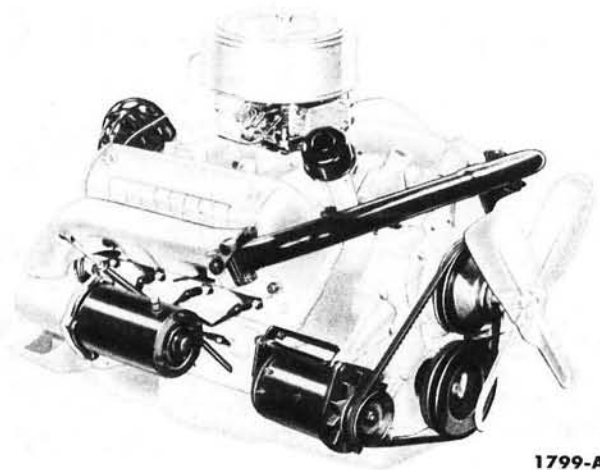

1799-A

FIG. 1—MD V-8 Engine—Typical

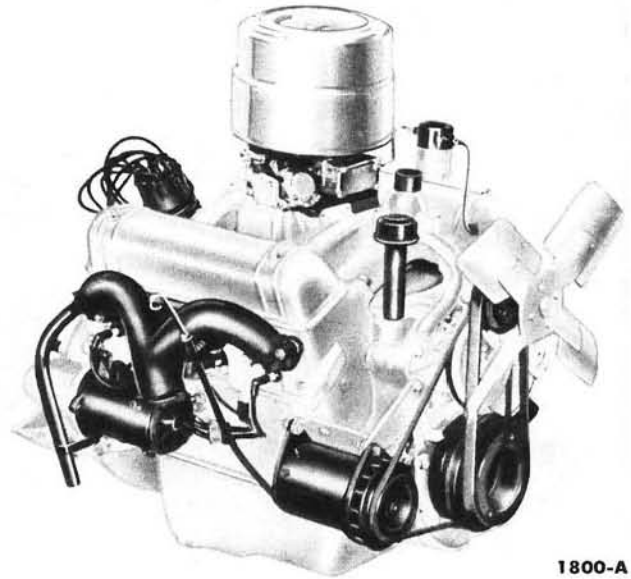

1800-A

FIG. 2—HD V-8 Engine—Typical

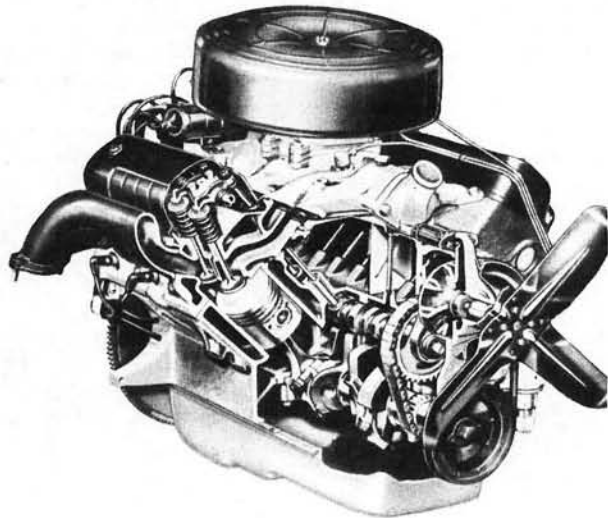

1415-B

FIG. 3—MD or HD V-8 Engine Sectional View—Typical

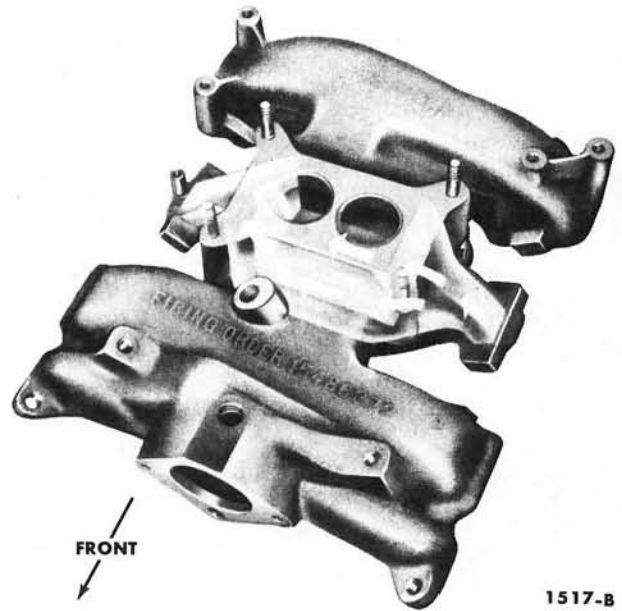

1517-B

FIG. 4—Intake Manifold Exhaust Gas Passage—Typical

front to rear on both banks E-I-I-E-E-I-I-E.

The cylinder head assemblies contain the valves and the valve rocker arm shaft assembly. Valve guides are an integral part of the head. Both the intake and exhaust valve assemblies used in the MD V-8 engines and the intake valves of the HD V-8 engines are the rotating-type which rotate each time the valve opens and closes. This rotation permits self cleaning of the seating, minimizing valve

seats of the 302 and 332 HD V-8 engines and the exhaust valve seats of the 272 and 292 HD V-8 engines are the insert type.

The valve springs have equal coil spacing which provides more positive valve action at high engine speed. Easy maintenance of valve lash is afforded by self locking adjusting screws.

The camshaft is supported by five insert-type bearings pressed into the

block.

The camshaft in the 272 and 292 engines is driven by a sprocket and timing chain in mesh with a sprocket on the crankshaft. A single strand chain is used on the MD V-8 engines and a double strand chain is used on the HD V-8 engines.

The camshaft in the 302 and 332 engines is driven by a gear in mesh with a gear on the crankshaft.

The crankshaft used in the 272 and

100% SATISFACTION GUARANTEED

BUY IT NOW!

Click Here To Order

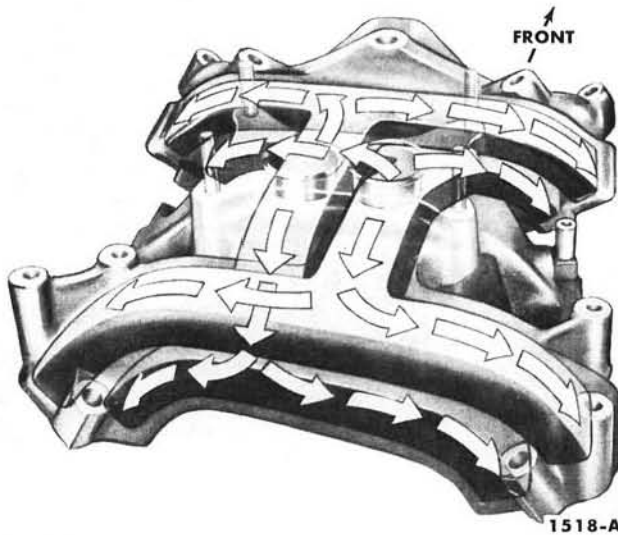

FIG. 5—Intake Manifold Fuel Passages—Typical

292 engines is made from a cast iron alloy, while the 302 and 332 engines have a forged steel crankshaft. Both types have integral counterweights and are statically and dynamically balanced. The crankshaft is supported by five insert-type bearings. Crankshaft end thrust is controlled by the flanges of the No. 3 main bearing.

The forged steel, “I” section connecting rods contain a bronze piston pin bushing. The connecting rod bearings are the insert-type.

The aluminum alloy, three ring, flat head-type pistons are of the auto-thermic design. This design provides controlled piston expansion which allows closer initial piston fits with-

out binding or excessive friction. The top compression ring is chrome-plated and the lower compression ring is phosphate-coated for extra protection against wear and scuffing. The oil control ring assembly of the 302 and 332 engines consists of 2 oil rings and a spring spacer. The oil control ring assembly of the 272 and 292 engines consists of a serrated spring and two chrome-plated steel rails.

ENGINE LUBRICATION SYSTEM

Oil from the oil pan sump is forced through the pressure-feed lubrication system (Fig. 6) by an externally mounted rotor-type pump which is driven by the distributor through an intermediate drive shaft. A spring loaded relief valve in the pump limits the maximum pressure of the system. Oil relieved by the valve is directed back to the intake side of the pump.

The engine is equipped with a full-flow-type filter which filters the entire output of the pump before the oil enters the engine. A built in by-pass provides oil to the engine in case the filter element becomes clogged. The by-pass is located in the hollow center bolt and consists of a spring loaded valve. When the element is clean and

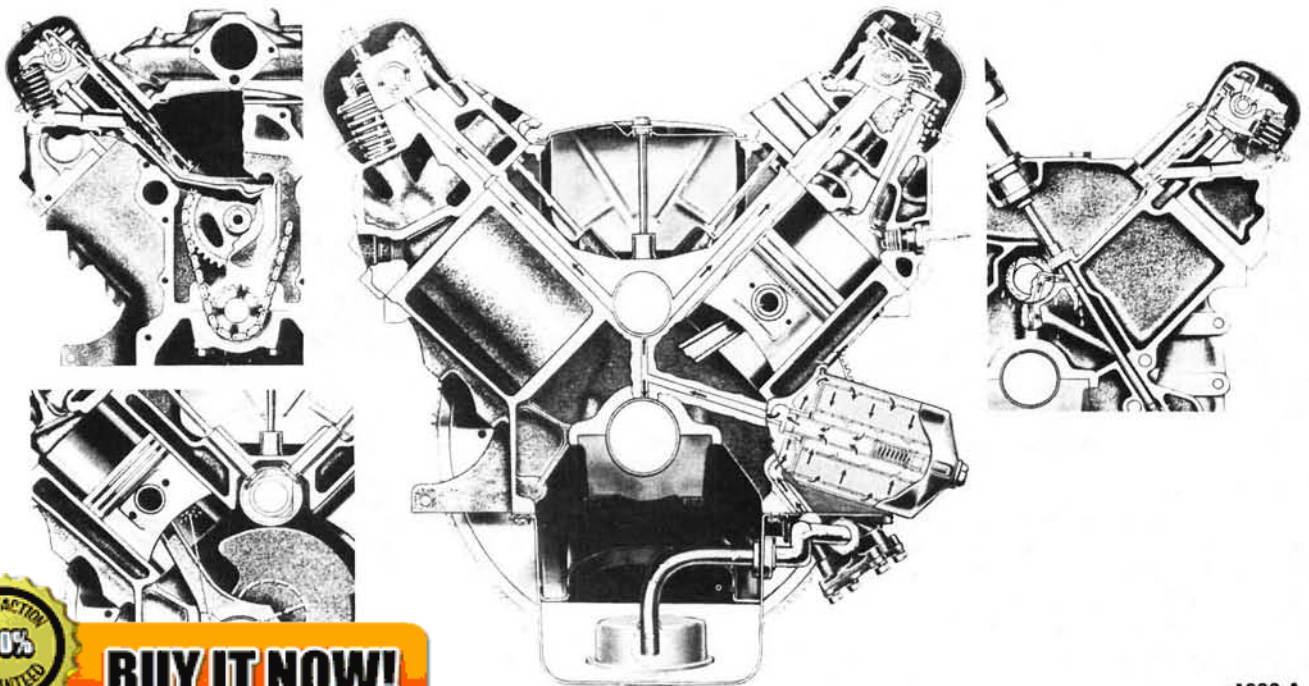

100% SATISFACTION GUARANTEED

BUY IT NOW!

Click Here To Order

PayPal American Express DISCOVER NOW! MasterCard VISA

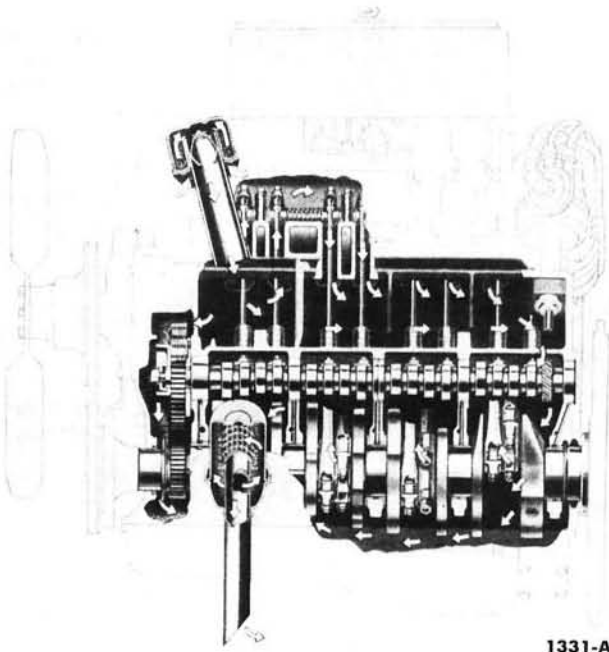

1331-A

FIG. 7—Crankcase Ventilation—Typical

oil will flow through it, the pressure difference between the inner and outer faces of the valve is not great enough to overcome the spring pressure behind the valve. Therefore, no oil flows through the by-pass. When the element is dirty and will not permit a sufficient flow of oil, the pressure acting on the inner face of the valve drops. If the pressure difference between the valve faces is great enough to overcome spring pressure, the valve will open. Oil then by-passes the element, maintaining an emergency supply of oil to the engine.

The oil from the filter flows into the main oil gallery which supplies oil to all the camshaft and main bearings through a drilled passage in each main bearing web.

The right valve rocker arm shaft assembly receives oil from a drilled passage at the No. 3 camshaft bearing. The oil is directed into the No. 2 valve rocker arm support. The oil from the support flows into the rocker shaft. Metered holes in the shaft permit lubrication of each rocker arm bushing and the valve and ball joint ends of the rocker arms. The excess oil flows down the rotating push rod

the push rod chamber through holes in the cylinder heads. In addition, each rocker arm shaft has an overflow pipe which exhausts excess oil into the push rod chamber. The overflow pipes are located at the front of the right cylinder head and at the rear of the left cylinder head.

The oil from the left valve rocker arm shaft assembly drains back into the oil pan through a hole at the rear of the block. This oil lubricates the distributor drive gears. The distributor shaft bushing is lubricated by oil from the No. 5 camshaft bearing.

The oil from the right valve rocker arm shaft assembly overflow tube lubricates the timing chain and sprockets or timing gears.

Oil slingers are provided to prevent leakage by directing oil away from the crankshaft front and rear oil seals. The front slinger is located between the cylinder front cover and the crankshaft sprocket or gear and throws oil onto the timing chain or timing gears. The oil then drips into the oil pan. The rear slinger, which is part of the crankshaft, deflects oil into the slinger trough which empties back into the oil pan.

Connecting rod bearings are lubricated by passages drilled from the crankshaft main journals to the connecting rod journals of the crankshaft. Cylinder walls are lubricated

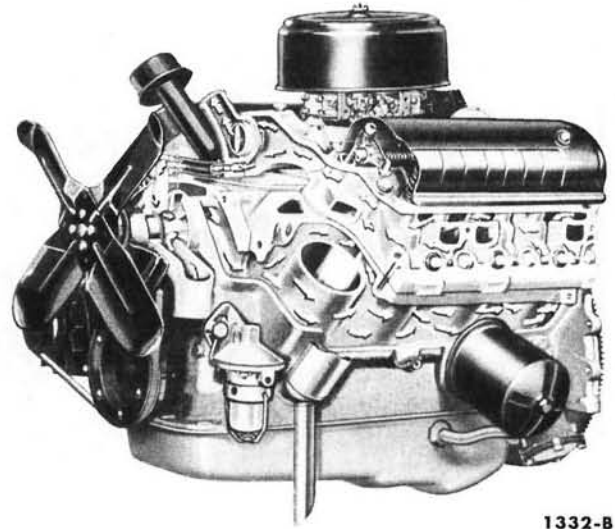

1332-B

FIG. 8—Cooling System—Typical

by oil sprayed from a hole drilled in each connecting rod.

CRANKCASE VENTILATION

Clean air flows into the front section of the push rod chamber where there are few contaminating vapors (Fig. 7). Here, the incoming air has a chance to warm up before contacting contaminating vapors originating in the crankcase. Warm ventilating air minimizes the formation of crankcase sludge.

The ventilating air is directed by a baffle, located on the push rod chamber cover, upward into the front of both valve rocker arm shaft chambers. The air is forced to the rear of the chambers and down into the rear section of the push rod chamber and through an opening in the block into the crankcase. Air is also diverted from the front section of the push rod chambers through holes in the front wall of the cylinder block to ventilate the timing chain or gear chamber.

The air from the crankcase is directed into the road draft outlet tube or crankcase ventilation tube by the forward motion of the truck which creates a partial vacuum at the road draft tube outlet or crankcase ventilation tube outlet.

COOLING SYSTEM

The coolant is drawn from the lower tank of the radiator by the water pump which delivers the coolant to the cylinder block (Fig. 8).

The coolant travels through cored passages to cool the entire length of

100% SATISFACTION GUARANTEED

BUY IT NOW!

Click Here To Order

PayPal American Express Cards Discover Novus MasterCard VISA

each cylinder wall. Upon reaching the rear of the cylinder block, the coolant is directed upward into the cylinder heads where it cools the combustion chambers, valves, and valve seats on its return to the front of the

engine.

The coolant from each cylinder head flows through the water passages in the intake manifold, into the water outlet connection and past the water thermostat, if it is open, into

the upper tank of the radiator. If the thermostat is closed, a small portion of the coolant is returned to the water pump for recirculation. The entire system is pressurized to 7 psi by a pressure-type radiator cap.

2 ENGINE REMOVAL AND INSTALLATION

Engine removal and installation procedures are separated according to truck body styles.

B-F-AND T-SERIES

REMOVAL

1. Remove the hood. Drain the cooling system and the crankcase. Remove the air cleaner, the fan, spacer, and belt, and the radiator and shroud as an assembly.

On trucks equipped with an air compressor, open the air reservoir drain cock. Disconnect the compressor air lines.

2. Disconnect the heater hoses at the engine and disconnect the generator wires. Remove the starter and dust seal. Disconnect the muffler inlet pipe(s) from the exhaust manifold(s), the primary wires at the ignition coil, and the choke control cable at the carburetor.

3. Remove the engine front support insulator bolts, accelerator return spring, water temperature and oil pressure sending unit wires at the sending units, and the engine ground strap. Disconnect the fuel line. Disconnect the vacuum brake booster hose at the intake manifold (if applicable).

On trucks with power steering, disconnect the power steering return line and the pump pressure line at the bracket on the frame left side member and drain the oil into a suitable container. Disconnect the power steering return line at the pump reservoir and the pressure line at the pump housing.

On engines with an electric fuel pump, disconnect the oil pressure safety switch wires at the switch.

On conventional drive or overdrive equipped trucks, disconnect the accelerator rod assembly at the accelerator

housing inspection cover, and the flywheel housing retaining bolts.

On trucks with an automatic transmission, disconnect the accelerator rod at the engine mounted bracket assembly. Remove the transmission cover plate with the accelerator assembly. Disconnect the oil cooler inlet and outlet hoses.

4. Support the transmission and attach the engine lifting hooks (Tool T53L-6000-B) and sling (Tool T53L-300-A). Raise the engine slightly, then carefully pull the engine from the transmission. Lift the engine out of the engine compartment. Install the engine on a work stand (Fig. 9 or 10). **On engines equipped with a ram's horn exhaust manifold, lower the engine on blocks and remove the right exhaust manifold and gasket. Remove the mount from the work stand and install it on the engine, then install the engine on the work stand.**

INSTALLATION

1. Attach the engine lifting hooks and sling, then remove the engine from the work stand. **On engines equipped with ram's horn exhaust manifolds, disconnect the mount from the work stand, then lower the engine on blocks. Remove the mount, then install the right exhaust manifold and gasket.** Place a new gasket over the muffler inlet pipe studs on the exhaust manifold(s).

2. Lower the engine carefully into the engine compartment. Make sure the exhaust manifold(s) are properly aligned with the muffler inlet pipe(s) and the dowels in the block engage the holes in the flywheel or converter housing.

On trucks with an automatic transmission, start the converter pilot into the crankshaft. Install the converter housing retaining bolts, the converter to flywheel nuts, and the converter housing front and lower covers. Connect the throttle rod at the engine mounted accelerator shaft and bracket assembly. Connect the accelerator

rod assembly to the accelerator assembly, and install the accelerator return spring. Connect the accelerator pedal. Connect the oil cooler inlet and outlet hoses.

On conventional drive or overdrive equipped trucks, start the transmission main drive gear into the clutch disc. It may be necessary to adjust the position of the transmission in relation to the engine if the input shaft will not enter the clutch disc. **If the engine "hangs up" after the shaft enters, turn the crankshaft slowly (transmission in gear) until the shaft splines mesh with the clutch disc splines.** Install the flywheel housing bolts, the flywheel housing inspection cover, the clutch lever retracting spring (all HD V-8 engines), the throttle control cable, the throttle control cable clamp (4-barrel carburetors), and the accelerator spring.

3. Remove the support from the transmission. Install the engine front support insulator bolts and tighten the bolts to specifications. Connect the muffler inlet pipes and tighten the nuts to specifications. Install the starter seal and starter.

4. Connect the coil primary wires, the choke control cable, the generator wires, the engine ground strap, the oil pressure and water temperature sending unit wires, and the fuel line.

On engines with an electric fuel pump, connect the oil pressure safety switch wires.

5. Connect the heater hoses. Install the radiator and shroud assembly, install the drive belts, spacer, and fan.

On trucks equipped with an air compressor, connect the reservoir to compressor line, and close the reservoir drain cock.

On trucks with power steering, connect the power steering return line to the pump reservoir and the pressure line at the pump housing. Connect the return line to the bracket on the frame left side member. Fill the power steering pump reservoir.

6. Fill the crankcase with the proper grade and quantity of engine oil and fill and bleed the cooling system. Install the hood. Run the engine at fast idle and check all gaskets and hose connections for leaks. Install the air cleaner.

On trucks with an automatic transmission, adjust the throttle linkage.

C-SERIES

REMOVAL

1. Release the cab lock and tilt the cab forward. Drain the cooling system and the crankcase.

2. Remove the clamps holding the throttle, choke, and accelerator cables, and the heater hoses to the radiator. Remove the fan assembly and the drive belts and remove the radiator and shroud as an assembly.

3. Remove the air cleaner and disconnect the heater hoses from the engine.

On trucks equipped with an air compressor, open the air reservoir drain cock. Disconnect the air line at the front of the engine and place the line against the frame side rail.

4. Disconnect the fuel line, then install a cap on the fuel line.

5. Disconnect the oil pressure and water temperature sending unit wires at the sending units. Disconnect the throttle control, choke control, and the accelerator cables at the carburetor, and the vacuum brake hose (if so equipped).

6. Remove the clutch release lever retracting spring (all HD V-8 engines).

7. Disconnect the primary wires at the ignition coil, and disconnect the generator wires.

On engines with an electric fuel pump, disconnect the oil pressure safety switch wires at the switch.

8. Remove the starter. Disconnect the radiator supply tank hose at the tank. Remove the oil filler pipe assembly clamp at the coolant supply tank bracket. Disconnect the muffler inlet pipes at the exhaust manifolds.

9. Support the transmission and remove the flywheel housing inspection cover and the flywheel housing to engine retaining bolts.

10. Remove the engine front support insulator bolts. Attach the engine lifting hooks (Tool T53L-6000-B) and sling (Tool T53L-300-A). Remove the engine and lower the engine on blocks and remove the right exhaust manifold and gasket. Remove the mount from the work stand and install it on the engine, then install the engine on the work stand (Fig. 9 or 10).

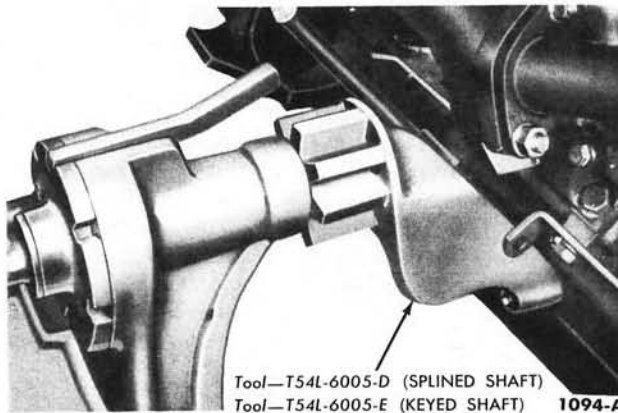
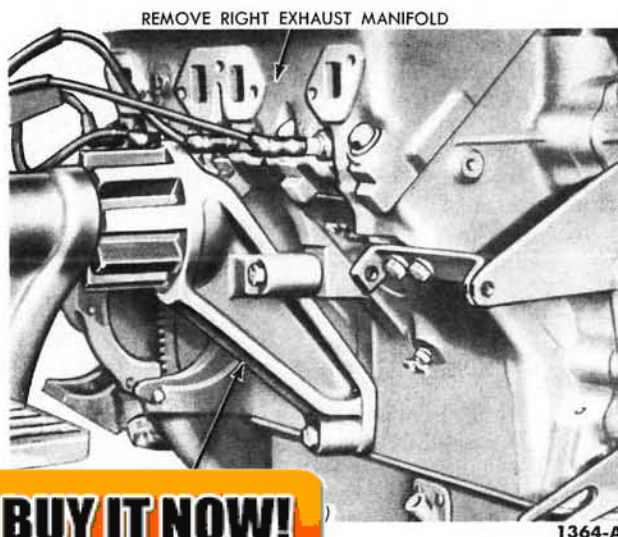

FIG. 9—Engine Mount—272 and 292 Engines



272 and 332 Engines

INSTALLATION

1. Place a new gasket over the exhaust manifold studs. Attach the engine lifting hooks and sling. Disconnect the mount from the work stand and lower the engine on blocks, then remove the mount from the engine and install the right exhaust manifold and gasket.

2. Lower the engine carefully into the engine compartment. Make sure the exhaust manifolds are properly aligned with the muffler inlet pipes and the dowels in the block engage the holes in the flywheel housing.

3. Install the flywheel housing to engine retaining bolts and install the engine front support insulator bolts. Remove the transmission support.

4. Install the flywheel housing inspection cover and the starter. Connect the muffler inlet pipes.

5. Connect the radiator supply tank hose, the coil and primary wires, and the vacuum brake hose (if so equipped). Connect the generator wires.

On engines with an electric fuel pump, connect the oil pressure safety switch wires.



BUY IT NOW!

Click Here To Order



6. Install and adjust the drive belts. Install the oil filler pipe assembly clamp to the radiator supply tank bracket.

7. Connect the accelerator cable, choke control cable, the throttle control cable, and the oil pressure and the temperature sending unit wires.

8. Remove the fuel line plug and connect the fuel line. Install the clutch release lever retracting spring (all HD V-8 engines).

9. Install the radiator and shroud as an assembly.

10. Connect the accelerator, choke and throttle control cables, and the heater hose to the radiator clamps. Install the fan assembly and the heater hoses.

On trucks equipped with an air compressor, connect the reservoir to compressor line, and close the reservoir drain cock.

11. Fill the crankcase with the proper grade and quantity of engine oil and fill the cooling system. Run the engine at fast idle and check all gaskets and hose connections for leaks. Install the air cleaner.

P-SERIES

The engine and transmission are removed as an assembly.

REMOVAL

1. Drain the cooling system and the crankcase. Remove the driver's seat assembly, the master cylinder inspection cover, and the steering column cover plates. Disconnect the accelerator pedal at the accelerator assembly, and the wires from the head light beam selector switch.

2. Remove the left wheel house panel and the center floor plate. Remove the screws fastening the right side of the engine rear cover panel to the right wheel house panel. Remove the bolts and nuts retaining the rear of the engine rear cover to the

engine rear cover plate will clear the slots. Remove the removable cross member.

3. Remove the air cleaner. Disconnect the battery ground cable, the water temperature and oil pressure sending unit wires at the sending units, coil primary wires, relay to starter cable at the starter, starter to frame cable at the starter, and the radiator upper and lower hoses.

4. Remove the engine front support insulator bolts. Disconnect the speedometer cable at the drive gear, the generator wires, and the brake vacuum hose at the intake manifold line. Disconnect the flexible fuel line at the fuel tank line and install a cap on the tank line. Disconnect the choke control cable at the carburetor. Remove the right exhaust manifold to muffler inlet pipe retaining nuts.

5. Remove the carburetor air cleaner stud and the engine rear support retaining capscrews. Remove the hand brake cable bracket and cable.

6. Disconnect the universal joint to transmission output shaft flange. Disconnect the manual control rods at the transmission lever (automatic transmission). Disconnect the clutch hydraulic slave cylinder hose (conventional drive or overdrive).

7. Using a floor crane, and engine lifting hooks (Tool T53L-6000-B) and sling (Tool T53L-300-A), remove the engine and transmission as an assembly.

INSTALLATION

1. Place a new gasket over the exhaust manifold studs. Using a floor crane, and the engine lifting hooks and sling, position the engine and transmission (as an assembly) in the chassis. Install the engine rear support capscrews, then install safety wire on the capscrews. Install the engine front support to frame cross member bolts and nuts, then tighten the nuts to specifications.

2. Install the hand brake cable. Connect the generator wires and the brake vacuum hose. Remove the cap from the fuel tank line and connect the flexible fuel line. Connect the choke control cable, the speedometer cable, and the right exhaust manifold to the muffler inlet pipe. Tighten the muffler inlet pipe nuts to 23-28 foot-pounds torque.

3. Connect the radiator upper and lower hoses, the starter to frame cable, the relay to starter cable, the coil primary wires, the water temperature and oil pressure sending unit wires, and the battery cable.

4. Install the frame cross member and connect the universal joint to transmission output shaft flange. Connect the clutch hydraulic slave cylinder hose and bleed the cylinder (conventional drive or overdrive). Position the engine cover assembly and the engine cover rear panel assembly and install the flange of the engine cover rear panel between the frame gussets and frame removable cross member. Remove the wedges.

5. Install the right side of the engine rear cover panel to the right wheel house panels.

6. Connect the head light beam selector switch wires and the accelerator pedal.

7. Install the engine left cover to wheel house panel, the steering column cover plates, and the master cylinder inspection cover. Install the driver's seat assembly.

8. Fill the crankcase with the proper grade and quantity of engine oil. Fill and bleed the cooling system.

9. Operate the engine at fast idle and check all gaskets and hose connections for leaks. Install the air cleaner anchor screw and the air cleaner.

10. On trucks with an automatic transmission, adjust the throttle linkage.



3 ENGINE SUPPORTS

ENGINE FRONT SUPPORT

The engine front support is shown in Figs. 11 and 12.

REMOVAL

Remove the nuts, washers, bolts, and lower insulator(s) from the front support. Raise the front of the engine, then remove the upper insulator(s).

INSTALLATION

Place the upper insulator(s) in position on the frame bracket, then lower the engine. Install the lower insulator(s), bolts, washers, and nuts. Tighten the bolts to specifications.

ENGINE REAR SUPPORT

The engine rear support is shown in Fig. 13.

REMOVAL

Remove the nut, bolt, lower insulator, and spacer from each rear support. Raise the rear of the engine, then remove the insulators.

INSTALLATION

Place the upper insulator in position on each side of the engine, then lower the engine. Install the spacer, the lower insulator, bolt and nut on each side of the engine. Tighten the bolts to specifications.

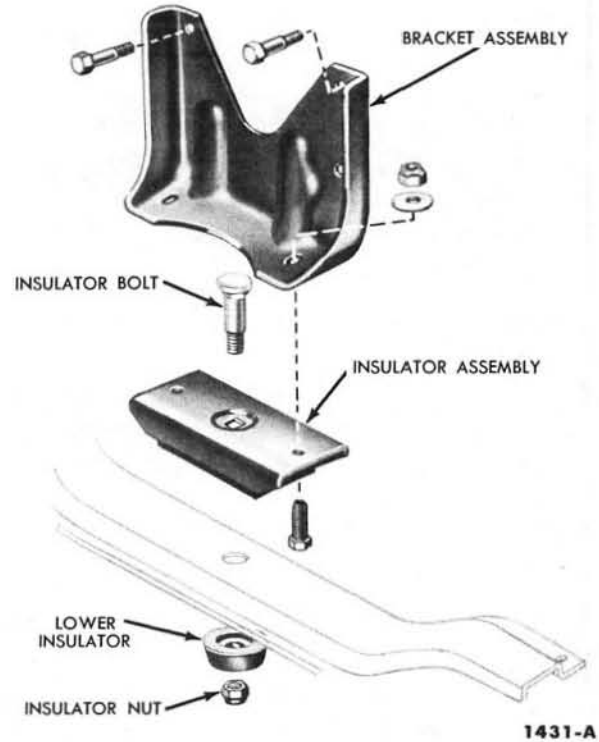
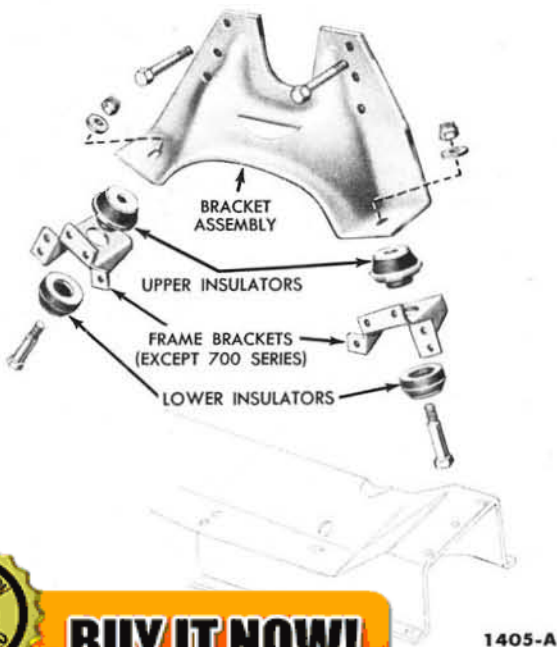

FIG. 12—Engine Front Support—302 and 332 Engines



1405-A
d 292 Engines

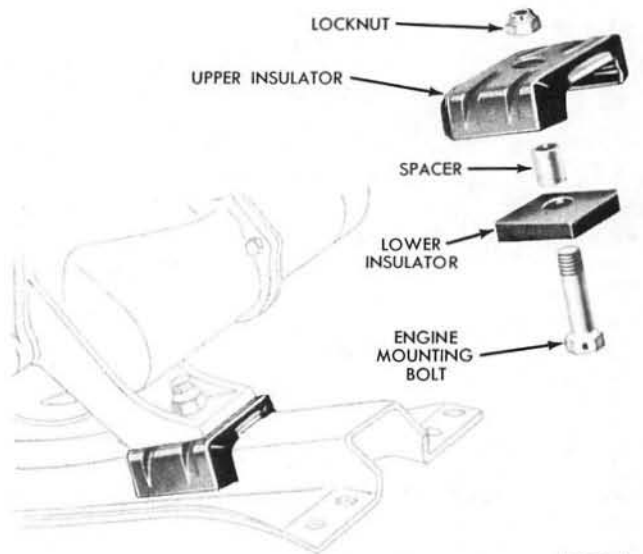

FIG. 13—Engine Rear Support



BUY IT NOW!

Click Here To Order

