



1958 FORD THUNDERBIRD

SHOP MANUAL



**BUY IT NOW!**

**Click Here To Order**



PayPal

AMERICAN EXPRESS  
Cards

DISCOVER  
NEWUS

MasterCard

VISA

FORD DIVISION FORD MOTOR COMPANY

Copyright © 2009, Forel Publishing Company, LLC, Woodbridge, Virginia

All Rights Reserved. No part of this book may be used or reproduced in any manner whatsoever without written permission of Forel Publishing Company, LLC. For information write to Forel Publishing Company, LLC, 3999 Peregrine Ridge Ct., Woodbridge, VA 22192

## **1958 Ford Thunderbird Shop Manual**

**EAN: 978-1-60371-008-4**

**ISBN: 1-60371-008-6**

Forel Publishing Company, LLC

3999 Peregrine Ridge Ct.

Woodbridge, VA 22192

Email address: [webmaster@ForelPublishing.com](mailto:webmaster@ForelPublishing.com)

Website: <http://www.ForelPublishing.com>



This publication contains material that is reproduced and distributed under a license from Ford Motor Company. No further reproduction or distribution of the Ford Motor Company material is allowed without the express written permission of Ford Motor Company.

---

## **Note from the Editor**

This product was created from the original Ford Motor Company's publication. Every effort has been made to use the original scanned images, however, due to the condition of the material; some pages have been modified to remove imperfections.

---

## **Disclaimer**

Although every effort was made to ensure the accuracy of this book, no representations or warranties of any kind are made concerning the accuracy, completeness or suitability of the information, either expressed or implied. As a result, the information contained within this book should be used as general information only. The author and Forel Publishing Company, LLC shall have neither liability nor responsibility to any person or entity with respect to any loss or damage caused, or alleged to be caused, directly or indirectly by the information contained in this book. Further, the publisher and author are not engaged in rendering legal or other professional services. If legal, mechanical, electrical, or other expert assistance is required, the professional should be sought.



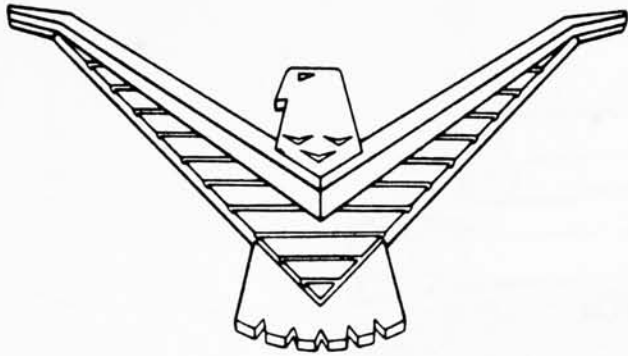

# CONTENTS

## 1958 THUNDERBIRD SHOP MANUAL

SERVICE DEPARTMENT  
FORD DIVISION  
MOTOR COMPANY



**BUY IT NOW!**

**Click Here To Order**



GROUP

POWER PLANT

1

CLUTCH, CONVENTIONAL TRANSMISSIONS,  
AND REAR AXLE

2

CRUISE-O-MATIC TRANSMISSION

3

CHASSIS SUSPENSION AND UNDERBODY

4

STEERING

5

BRAKES

6

GENERATING AND STARTING SYSTEMS

7

LIGHTS, INSTRUMENTS, AND ACCESSORIES

8

BODY MAINTENANCE AND REPAIR

9

DOORS, DECK LID, AND  
FRONT SHEET METAL

10

INTERIOR TRIM, SEATS,  
AND WINDOWS

11

MAINTENANCE, LUBRICATION,  
AND SPECIAL TOOLS

12

SPECIFICATIONS

13

## FOREWORD

*This manual provides information for the proper servicing of the 1958 Thunderbird. Service information on air conditioning is covered in a separate manual. The descriptions and specifications contained in this manual were in effect at the time the manual was approved for printing. The Ford Division of Ford Motor Company, whose policy is one of continuous improvement, reserves the right to discontinue models at any time, or change specifications or design, without notice and without incurring obligation.*

SERVICE DEPARTMENT  
**FORD DIVISION**  
FORD MOTOR COMPANY



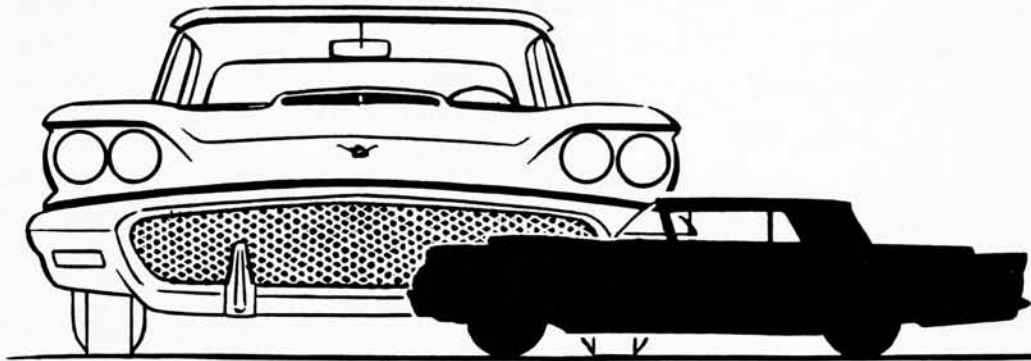

# 1958 THUNDERBIRD SHOP MANUAL

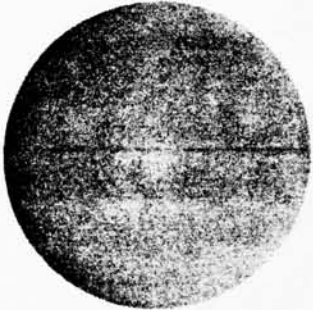

## GROUP 1 POWER PLANT

	Page
<b>PART 1</b> ENGINE .....	1-2
<b>PART 2</b> IGNITION SYSTEM .....	1-44
<b>PART 3</b> FUEL SYSTEM .....	1-58
<b>PART 4</b> COOLING SYSTEM .....	1-77



**BUY IT NOW!**

**Click Here To Order**



## PART 1 ENGINE

Section	Page	Section	Page	Section	Page
1 Description	1-2	Valve Rocker Arm Shaft Assembly	1-27	Camshaft and Bearings	1-34
2 General Engine Trouble Shooting	1-7	Cylinder Heads	1-27	Crankshaft	1-35
3 Tune-Up	1-10	Hydraulic Valve Lifters	1-28	Connecting Rods	1-35
4 Tests and Adjustments (Engine In Chassis)	1-11	Piston and Connecting Rod	1-28	Piston, Pins, and Rings	1-35
Camshaft Lobe Lift	1-11	Oil Pump	1-30	Main and Connecting Rod Bearings	1-37
Valve Timing	1-12	8 Cleaning, Inspection, and Reconditioning	1-30	Conventional Flywheel	1-38
Valve Clearance	1-12	Intake Manifold	1-30	Cylinder Block	1-39
Manifold Vacuum Test	1-13	Exhaust Manifold and Exhaust Gas Control Valve	1-30	Oil Pan and Oil Pump	1-40
Engine Compression Test	1-13	Valve Rocker Arm Shaft Assembly	1-30	9 Repair Operations (Engine In Chassis)	1-40
5 Engine Removal and Installation	1-14	Push Rods	1-30	Engine Supports	1-40
6 Engine Disassembly and Assembly (Engine Removed from Chassis)	1-16	Cylinder Heads	1-30	Intake Manifold	1-41
7 Disassembly and Assembly of Component Parts	1-27	Valves	1-32	Cylinder Heads	1-42
		Hydraulic Valve Lifters	1-34	Cylinder Front Cover and Timing Chain	1-42
		Timing Chain	1-34	Camshaft	1-42
				Oil Pan and Oil Pump	1-42
				Oil Filter	1-43
				Exhaust System	1-43

## 1 DESCRIPTION

The Interceptor V-8 "Thunderbird Special" engine (Figs. 1 and 2) has a 4.00-inch bore and a 3.50-inch stroke and a total piston displacement of 352 cubic inches. It has a compression ratio of 10.2:1. The engine is identified by a decal on the air cleaner bearing the name of the engine. It can be identified also by the letter "H" at the beginning of the serial number on the patent plate.

1722-A

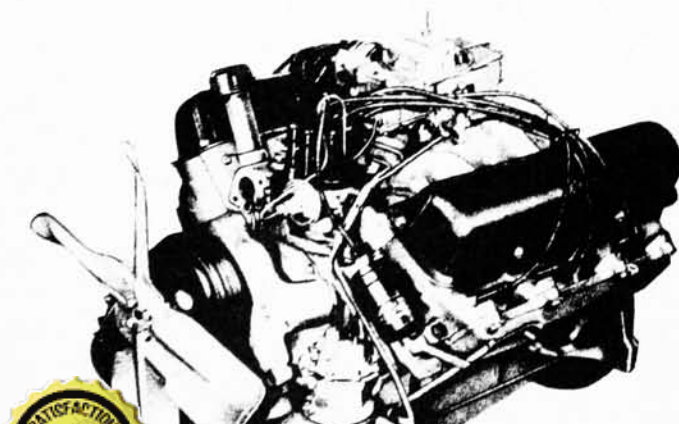

**100% SATISFACTION GUARANTEED**

**BUY IT NOW!**

**Click Here To Order**







"Special" Engine

# PLANT

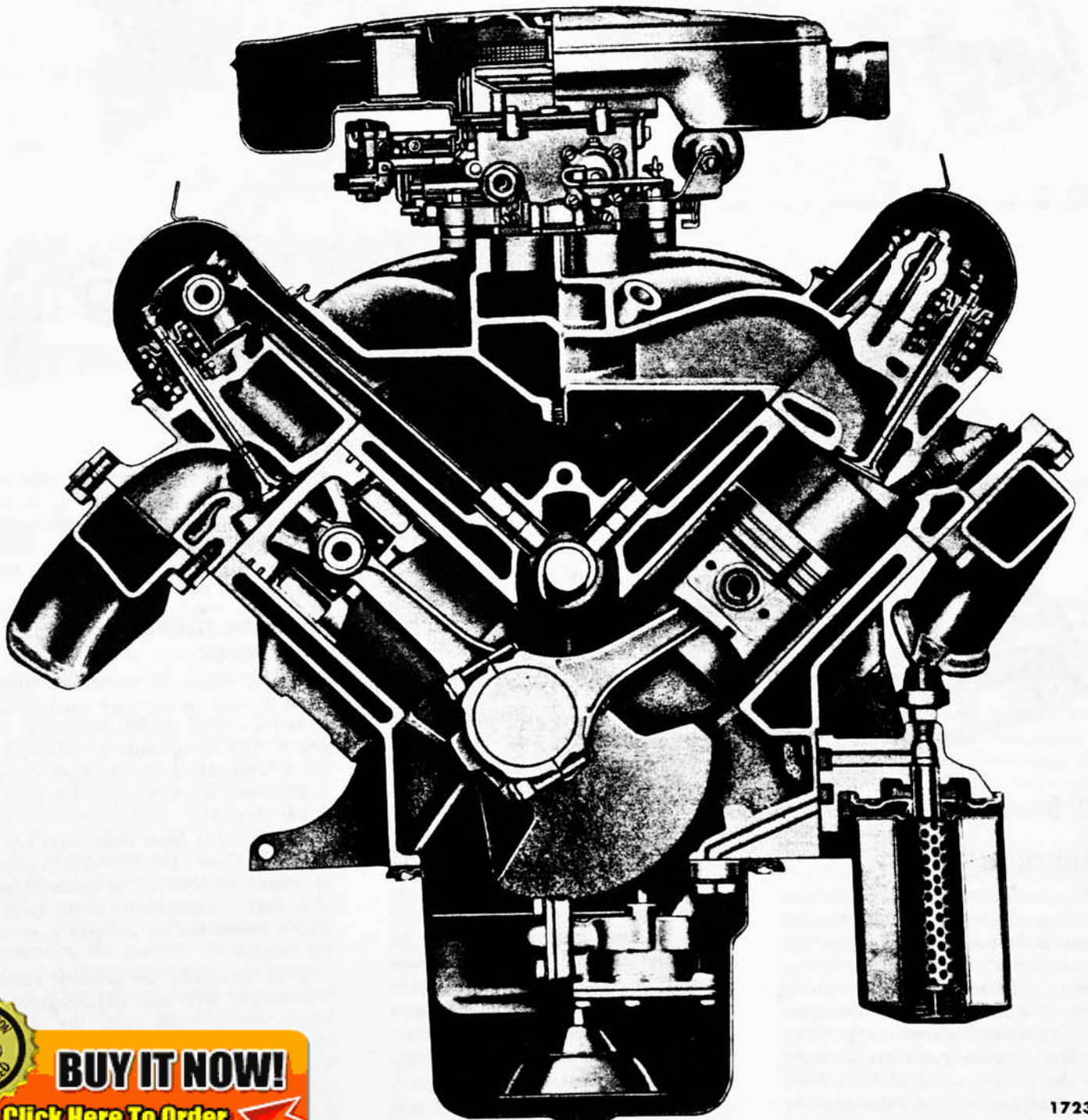

**BUY IT NOW!**

**Click Here To Order**



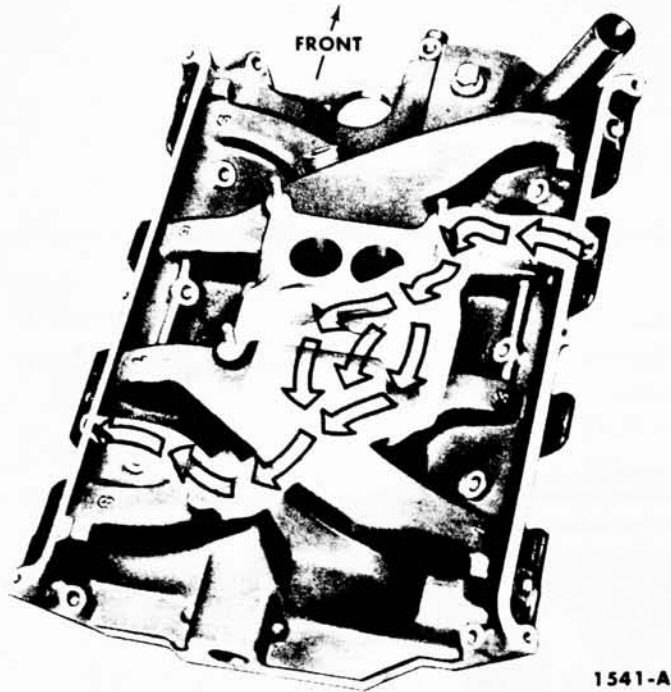

FIG. 3—Intake Manifold Exhaust Gas Passages

1541-A

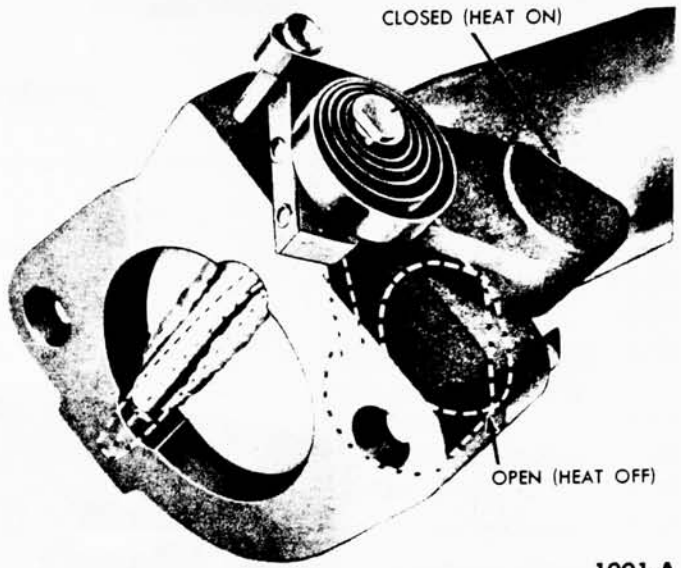

FIG. 4—Exhaust Gas Control Valve

1001-A

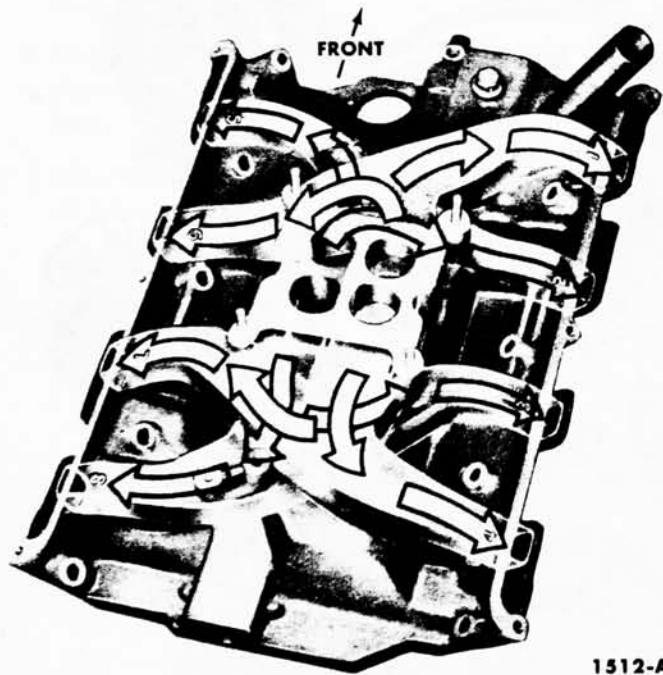

FIG. 5—Intake Manifold Fuel Passages

1512-A

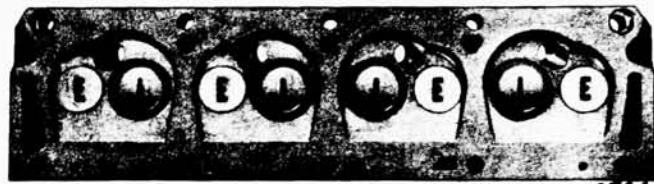

FIG. 6—Valve Port Arrangement

1724-A

**MANIFOLDS**

The intake manifold, which also serves as the valve tappet chamber cover, contains a passage through the center section and under the carburetor through which hot exhaust gases are directed to assist in vapor-

When the valve is closed or in the "heat on" position, part of the exhaust gases are directed from the right exhaust manifold, through the heat riser passage, to the left exhaust manifold. When the valve opens "heat off," more of the exhaust gases from the left manifold are permitted to flow directly out the exhaust system in the normal manner.

The intake manifold has two sets of fuel passages, each with its own separate inlet connection to the car-

buretor (Fig. 5). The right side of the carburetor feeds Nos. 1, 4, 6, and 7 cylinders and the left side feeds Nos. 2, 3, 5, and 8 cylinders.

The distributor is mounted at the left front of the intake manifold.

**CYLINDER HEADS AND BLOCK**

The cylinders are numbered from front to rear on the right bank 1, 2, 3, and 4 and on the left bank 5, 6, 7, and 8. The firing order is 1-5-4-2-6-3-7-8. The valves are arranged from front to rear on both banks E-I-E-I-E-I-E (Fig. 6).

The cylinder head assemblies contain the valves and the valve rocker arm shaft assembly. The combustion chambers are machined in the head. Valve guides are an integral part of the head.

Both the intake and exhaust valve assemblies are the rotating-type which rotate each time the valve opens and closes. Lubrication of the valve stems is controlled by umbrella-type valve stem seals which fit over the top of the valve stems. The valve springs have equal coil spacings which provide more positive valve

**100% SATISFACTION GUARANTEED**

**BUY IT NOW!**

**Click Here To Order**

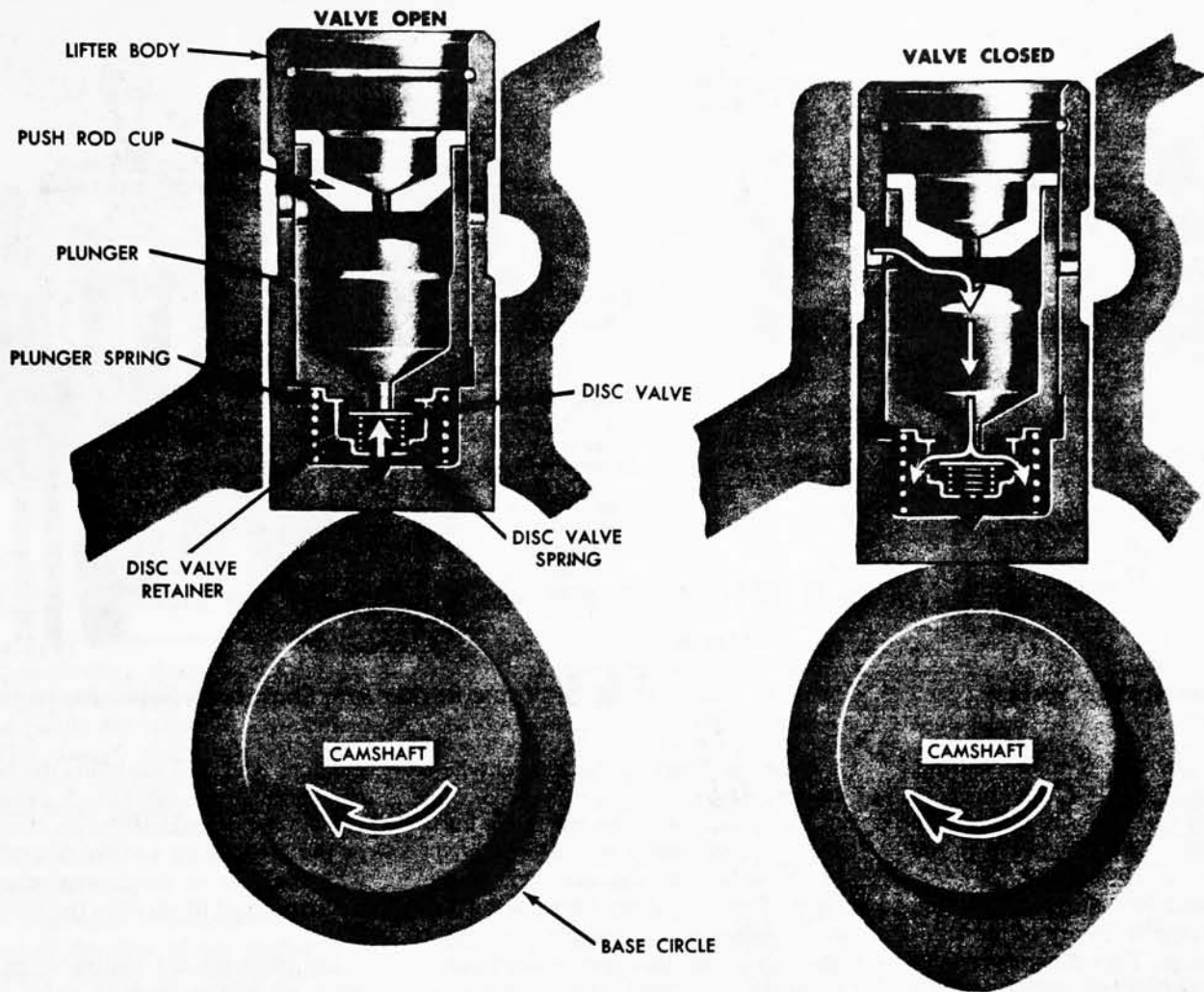

1717-A

**FIG. 7—Hydraulic Valve Lifter Operation—Typical**

action at high engine speed. A damper spring is installed inside the valve spring to assist in preventing valve bounce and floating at high rpm.

Hydraulic valve lifters are used which provide zero valve lash and minimizes valve train noise. The operation and parts identification of the hydraulic valve lifters are shown in Fig. 7. When the valve is closed, the lifter assembly is on the base circle of the camshaft lobe and the valve push rod is in its lowest position. With the lifter assembly in this position, the plunger spring expands forcing the plunger upward. This action is transmitted to the valve rocker via the valve push rod until

sure into the plunger. This creates a pressure differential above and below the valve disc. The high pressure above the valve disc forces the valve disc open and the oil fills the area below the plunger equalizing the pressure on each side of the valve disc.

Whenever clearance between the valve and the valve rocker arm tends to be present, the plunger spring expands pushing the plunger until there is solid contact between all parts of the valve train mechanism.

As the camshaft rotates (valve opening) the valve lifter is raised and the sudden increase in oil pressure below the plunger forces the valve disc closed and the lifter becomes a hydraulic ram. During this period a slight leakage of oil from below the plunger occurs. As the high point on the camshaft lobe rotates past the lifter, the push rod forces the valve lifter down and reseats the valve. The

pressure on the oil below the plunger is relieved and the valve disc opens so the chamber can again be filled. This cycle is repeated at each revolution of the camshaft.

The push rods are solid steel with oil cushioned sockets. Inasmuch as there is no valve lash adjustment with hydraulic valve lifters, the valve rocker arms do not have adjusting screws.

The camshaft is supported by five insert-type bearings pressed into the block. It is driven by a sprocket and timing chain in mesh with a sprocket on the crankshaft. Camshaft end play is controlled by a thrust button and spring located between the camshaft sprocket bolt and the cylinder front cover. An eccentric, bolted to the front end of the camshaft, operates the fuel pump.

The crankshaft is supported by five insert-type main bearings. Crankshaft end thrust is controlled by the

**100% SATISFACTION GUARANTEED**

**BUY IT NOW!**

**Click Here To Order**

PayPal, American Express, Discover, MasterCard, VISA

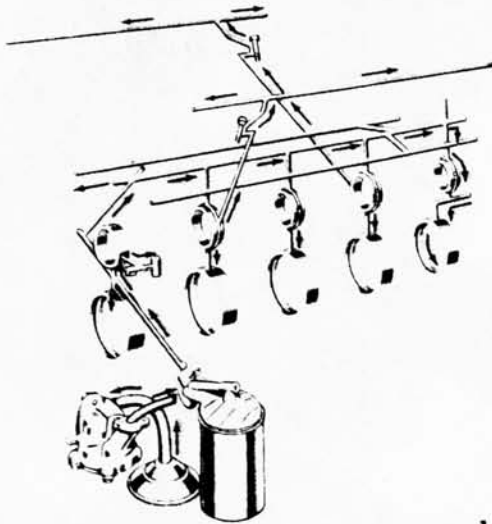

1514-A

FIG. 8—Lubrication System

flanges of the No. 3 main bearing.

The forged steel, "I" section connecting rods contain a bronze piston pin bushing. The connecting rod bearings are the insert-type.

The aluminum alloy, three ring, flat head-type pistons are of the auto-thermic design. This design provides controlled piston expansion which allows closer initial piston fits without binding or excessive friction. The top compression ring is chrome-plated and the lower compression ring is phosphate-coated for extra protection against wear and scuffing. The oil control ring assembly consists of a serrated spring and two chrome-plated steel rails.

#### LUBRICATION SYSTEM

Oil from the oil pan sump, located in the front of the oil pan, is forced through the pressure-type lubrication system (Fig. 8) by a rotor-type oil pump. The oil pump, mounted in the front of the crankcase, is driven by the distributor through an intermediate drive shaft. A spring loaded relief valve in the pump limits the maximum pressure of the system. Oil from the pump is directed back to the oil pan.

bypass the filter, if the element becomes clogged.

From the filter, the oil flows into the main oil gallery which is located in the center of the valve chamber floor. The oil gallery supplies oil to each individual camshaft bearing, through drilled passages in the block. Passages are drilled from each camshaft bearing to each main bearing. Number 1 camshaft bearing feeds No. 1 main bearing, and No. 2 camshaft bearing feeds No. 2 main bearing, etc. The oil then flows through notches or grooves in the main bearings to lubricate the crankshaft journals. A metering plug at the front of the main oil gallery allows any air that may be trapped in the oil to escape.

The crankshaft is drilled from the main bearings to the connecting rod bearings. The oil flow is as follows:

Main Bearing	Serves	Connecting Rod Bearing
No. 1	Serves	No. 1
No. 2	Serves	Nos. 2 and 5
No. 3	Serves	Nos. 3 and 6
No. 4	Serves	Nos. 4 and 7
No. 5	Serves	No. 8

A small groove is located in the connecting rod at the mating face where the cap contacts the connecting rod. This groove is used as an oil squirt hole for cylinder wall lubrication. Oil from the connecting rod squirt hole lubricates the opposite

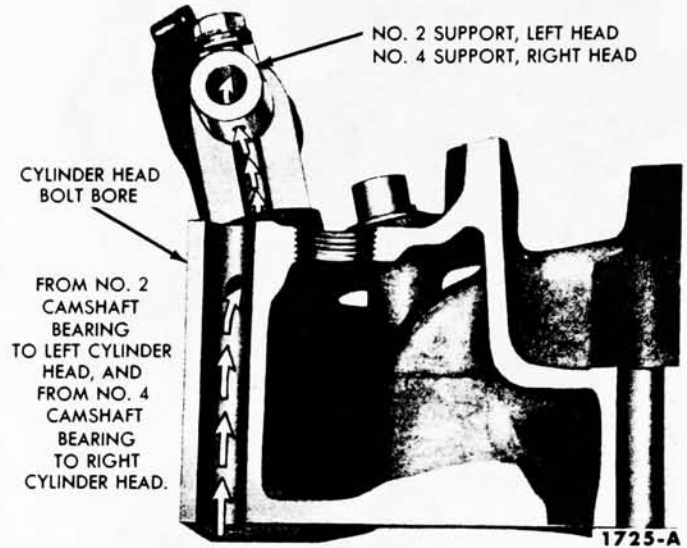

1725-A

FIG. 9—Valve Rocker Arm Shaft Lubrication Passages

cylinder-wall. For example, the No. 1 connecting rod oils No. 5 cylinder, etc. As the crankshaft turns, the hole in the connecting rod bearing aligns with the hole in the journal causing a direct squirt of oil onto the cylinder wall.

Oil passages are drilled from the main oil gallery to each valve lifter oil gallery. Oil from here feeds the valve lifter assemblies. A reservoir at each valve lifter bore boss traps oil so that oil is available for valve lifter lubrication as soon as the engine starts.

An oil passage is drilled from No. 2 camshaft bearing web to the left cylinder head between Nos. 5 and 6 cylinders to lubricate the valve rocker arm shaft assembly (Fig. 9). The oil passage in the cylinder head is drilled from the cylinder head bolt bore to the No. 2 valve rocker arm shaft support. The oil flows through the valve rocker arm shaft through drilled holes in each valve rocker arm to lubricate the bushing and both ends of the valve rocker arm. The excess oil spirals down the rotating push rods and lubricates the push rod seats. The right valve rocker arm shaft assembly is similarly lubricated from No. 4 camshaft bearing via the No. 4 valve rocker arm shaft support. A baffle located under the valve rocker arm shaft assembly shields the valve stems from oil splash. Excess oil is returned to the

**100% SATISFACTION GUARANTEED**

**BUY IT NOW!**

**Click Here To Order**

PayPal | American Express | Discover | MasterCard | VISA

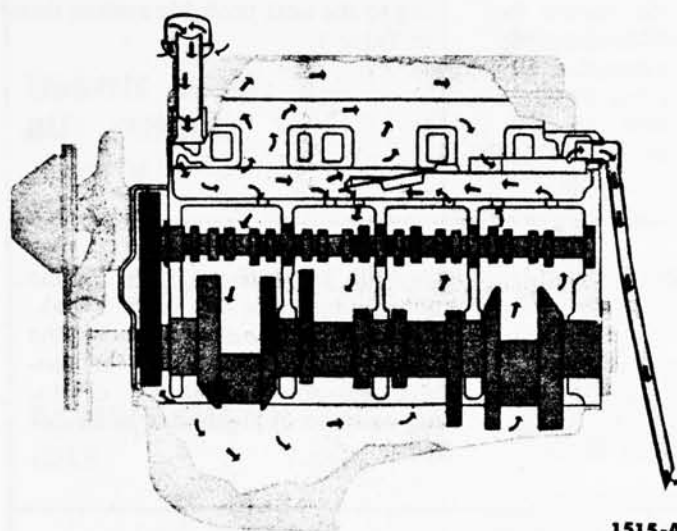

1515-A

FIG. 10—Crankcase Ventilation System

oil pan through drain back holes located at each end of the cylinder head and in the tappet chamber floor.

The timing chain and sprockets are splash lubricated by a jiggle pin in the main gallery front plug.

#### CRANKCASE VENTILATION

A crankcase ventilation tube is located at the rear of the engine. The forward motion of the car causes a partial vacuum to be formed at the tube. This vacuum action causes air to be drawn through the engine from the oil filler cap located at the front of the intake manifold (Fig. 10). The filler cap contains a filtering element which filters the incoming air.

From the filler cap, the air flows into the front section of the valve push rod chamber where there are

few contaminating vapors. Here, the incoming air has a chance to warm up before contacting contaminating vapors originating in the crankcase. Warm ventilating air minimizes the formation of crankcase sludge.

The ventilating air is directed by a baffle, located on the underside of the intake manifold, upward into the front of both valve rocker arm chambers. The baffle also directs air to the front of the lower crankcase and into the timing chain chamber.

Air from the valve rocker arm chamber and from the crankcase flows into the rear of the valve push rod chamber. All air is then directed out the crankcase ventilation tube.

#### COOLING SYSTEM

The coolant is drawn from the lower tank of the radiator by the

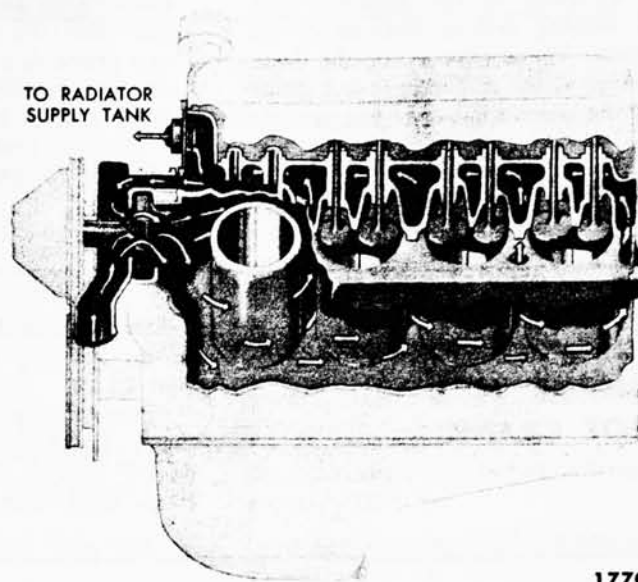

1770-A

FIG. 11—Cooling System

water pump which delivers the coolant to the cylinder block (Fig. 11).

The coolant travels through cored passages to cool the entire length of each cylinder wall. Upon reaching the rear of the cylinder block, the coolant is directed upward into the cylinder heads where it cools the combustion chambers, valves, and valve seats on its return to the front of the engine.

The coolant from each cylinder head flows through the water passages in the intake manifold and past the water thermostat, if it is open, into the radiator supply tank. If the thermostat is closed, a small portion of the coolant is returned to the water pump for recirculation. The entire system is pressurized to 13-15 psi by a pressure-type radiator cap.

## 2 GENERAL ENGINE TROUBLE SHOOTING

Poor engine performance can be caused by the need of a general engine tune-up, by gradual wear of engine parts, or by a sudden parts failure. A good trouble diagnosis will indicate the need of a complete engine tune-up, individual adjustments, part(s) replacement or overhaul, or the need of a complete engine over-

misses; rough engine idle; poor acceleration; engine does not develop full power, or has poor high speed performance; excessive fuel consumption; engine overheats; or the engine fails to reach normal operation temperature.

Table 1 is a general trouble shooting chart which lists basic engine troubles with procedures and checks to be performed to help isolate the cause of the trouble in a particular system. The reference after each check refers to that part of the manual which covers, in detail, checking procedures as well as cor-

rections to be made in the various systems. When a particular trouble can not be traced to a definite system by a simple check, the possible systems that could be at fault are listed in the order of their probable occurrence; therefore, in most cases, the checks should be made in the order listed. Some consideration, however, should be given to logical order. For example, if the spark plugs are removed for testing and they are not the cause of the trouble, and several checks later calls for a compression test, to save time, check the compression while the spark plugs are out.

**100% SATISFACTION GUARANTEED**

**BUY IT NOW!**

**Click Here To Order**

Keep running engine parts

PayPal

Discover Cards

AMERICAN EXPRESS

MasterCard

VISA

Separate trouble shooting charts are included in the ignition, fuel, and cooling system sections of the manual. These charts list the basic troubles listed in Table 1, but cover only the items relating to the particu-

lar system under consideration. For example, in Table 1 under Poor Acceleration, the ignition system is listed as a probable cause of the trouble. In the Ignition System Trouble Shooting Chart under Poor Acceleration, all

the ignition system items that affect acceleration are listed. These items should all be checked before proceeding to the next probable system listed in Table 1.

**TABLE 1—General Engine Trouble Shooting**

<p><b>ENGINE WILL NOT CRANK</b></p>	<p>The cause of this trouble is usually in the starting system (Group 7—Part 2). If the starting system is not at fault, check for a hydrostatic lock or a seized engine. Remove the spark plugs, then attempt to crank the en-</p>	<p>gine with the starter. If the engine cranks, it indicates that water is leaking into the cylinders. Remove the cylinder head(s) and inspect the gasket(s) and/or head(s) for cracks. Also examine the cylinder block for cracks.</p>
<p><b>ENGINE CRANKS NORMALLY, BUT WILL NOT START</b></p>	<p>Check the fuel supply. If there is sufficient fuel in the tank, the cause of the trouble probably lies in either the ignition or the fuel system. To isolate the cause: Remove the ignition wire from one spark plug, and insert a piece of proper sized metal rod in the insulator so that it protrudes from the insulator. With the ignition on and the</p>	<p>starter cranking the engine, hold the end of the rod approximately 3/16 inch from the cylinder block. If there is no spark or a weak spark, the cause of the trouble is in the ignition system (Group 1—Part 2). If the spark is good, check the spark plugs (Group 1—Part 2). If the spark plugs are not at fault, check the fuel system (Group 1—Part 3). If the fuel system is not at fault, check the valve timing (Group 1—Part 1).</p>
<p><b>ENGINE STARTS, BUT FAILS TO KEEP RUNNING</b></p>	<p>If the engine starts and runs for a few seconds, then stops, check the:</p>	<p>Fuel system (Group 1—Part 3). Ignition system (Group 1—Part 2).</p>
<p><b>ENGINE RUNS, BUT MISSES</b></p>	<p>First, determine if the miss is steady or erratic and at what speed the miss occurs by operating the engine at various speeds under load. <b>Misses steady at all speeds.</b> Isolate the miss by operating the engine with one cylinder not firing. This is done by operating the engine with the ignition wire removed from one spark plug at a time, until all cylinders have been checked. Ground the spark plug wire removed. If the engine speed changes when a particular cylinder is shorted out, that cylinder was delivering power before being shorted out. If no change in the engine operation is evident, the miss was caused by that cylinder not delivering power before being shorted out, check the:</p>	<p>Ignition system (Group 1—Part 2). Engine compression to determine which mechanical component of the engine is at fault (page 1-13). <b>Misses erratically at all speeds.</b> If the miss cannot be isolated in a particular cylinder, check the: Exhaust gas control valve (page 1-30). Ignition system (Group 1—Part 2). Fuel system (Group 1—Part 3). Engine compression to determine which mechanical component of the engine is at fault (page 1-13). Exhaust system for excessive back pressure. Cooling system for internal leaks and/or for a condition that prevents the engine from reaching normal operating temperature (Group 1—Part 4).</p>

**100% SATISFACTION GUARANTEED**  
**BUY IT NOW!**  
**Click Here To Order**

PayPal American Express Discover MasterCard VISA

TABLE 1—General Engine Trouble Shooting (cont'd)

<p><b>ENGINE RUNS, BUT MISSES (cont'd)</b></p>	<p><b>Misses at idle only.</b> Check the:                  Fuel system (Group 1—Part 3).                  Ignition system (Group 1—Part 2).                  Vacuum booster pump, lines and fittings for leaks.                  Engine compression for low compression (page 1-13).</p>	<p><b>Misses at high speed only.</b> Check the:                  Ignition system (Group 1—Part 2).                  Fuel system (Group 1—Part 3).                  Cooling system for overheating or internal leakage (Group 1—Part 4).</p>
<p><b>ROUGH ENGINE IDLE</b></p>	<p>Check the:                  Fuel system (Group 1—Part 3).                  Ignition system (Group 1—Part 2).                  Exhaust gas control valve (page 1-30)                  Vacuum booster pump, lines and fittings for leaks.</p>	<p>Power brake vacuum booster for leaks (Group 6—Part 2).                  Engine supports for looseness (Group 1—Part 1).                  Improper cylinder head bolt torque (Group 1—Part 1).</p>
<p><b>POOR ACCELERATION</b></p>	<p>Check the:                  Ignition system (Group 1—Part 2).                  Fuel system (Group 1—Part 3).                  Exhaust gas control valve (page 1-30).                  Brakes for proper adjustment (Group 6).</p>	<p>Clutch for slippage—Conventional Drive and Overdrive Transmission (Group 2—Part 1).                  Cruise-O-Matic transmission for proper adjustment (Group 3—Part 2).</p>
<p><b>ENGINE DOES NOT DEVELOP FULL POWER, OR HAS POOR HIGH SPEED PERFORMANCE</b></p>	<p>Determine if the trouble exists when the engine is cold, at normal operating temperature, or at all engine temperatures.  <b>Engine cold.</b> Check the:                  Exhaust gas control valve (page 1-30).                  Fuel system (Group 1—Part 3).                  Cooling system if engine reaches operating temperature slowly (Group 1—Part 4).  <b>Engine at normal operating temperature.</b> Check the:                  Exhaust gas control valve (page 1-30).                  Fuel system (Group 1—Part 3).</p>	<p><b>All engine temperatures.</b> Check the:                  Engine compression (page 1-13).                  Ignition system (Group 1—Part 2).                  Fuel system (Group 1—Part 3).                  Camshaft lobe lift (page 1-11).                  Valve timing (page 1-12).                  Cooling system if the engine overheats (Group 1—Part 4).                  Exhaust system for excessive back pressure.                  Torque converter (Group 3—Part 3).                  Brake adjustment (Group 6).                  Tire pressure (Group 4—Part 3).</p>
<p><b>EXCESSIVE FUEL</b></p>	<p>Determine the actual fuel consumption with test equipment installed in the car.                  If the test indicates that the fuel consumption is not excessive, demonstrate to the owner how improper driving habits will affect fuel consumption.</p>	<p>If the test indicates that the fuel consumption is excessive, make a preliminary check of the following items before proceeding to the fuel and ignition systems.  <b>Preliminary checks</b>                  Tires (Group 4—Part 3).</p>

**100% SATISFACTION GUARANTEED**  
**BUY IT NOW!**  
 Click Here To Order

PayPal American Express Discover MasterCard VISA

TABLE 1—General Engine Trouble Shooting (cont'd)

<b>EXCESSIVE FUEL CONSUMPTION (cont'd)</b>	Wheel alignment (Group 4—Part 1). Brakes (Group 6). Exhaust gas control valve (page 1-30). Odometer calibration (Group 8—Part 1).	Ignition timing (Group 1—Part 2). <b>Fuel system</b> (Group 1—Part 3). <b>Ignition system</b> (Group 1—Part 2). <b>Engine compression</b> (page 1-13). <b>Cooling system</b> (Group 1—Part 4). <b>Torque converter</b> (Group 3—Part 6).
<b>ENGINE OVERHEATS</b>	Temperature sending unit (Group 8—Part 1). Temperature gauge (Group 8—Part 1). Exhaust gas control valve (page 1-30).	Cylinder head bolt torque (Group 1—Part 1). Cooling system (Group 1—Part 4). Ignition timing (Group 1—Part 2). Valves (page 1-32). Exhaust system. Brakes (Group 6).
<b>ENGINE FAILS TO REACH NORMAL OPERATING TEMPERATURE</b>	Temperature sending unit (Group 8—Part 1). Temperature gauge (Group 8—Part 1).	Engine thermostat (Group 1—Part 4).

### 3 TUNE-UP

A tune-up is a systematic procedure for testing various engine components, and, if necessary, bringing them within recommended specifications to restore engine efficiency and performance.

The Tune-Up Schedule (Table 2) is applicable for either a minor or major tune-up. A minor tune-up is recommended each 6000 miles and a major tune-up is recommended each 12,000 miles.

The reference after each operation refers to that part of the manual which describes, in detail, the procedure to be followed. Perform the operations in the sequence listed.

TABLE 2—Tune-Up Schedule

Operation	Perform on		Recommended Procedure
	Minor	Major	
<b>SPARK PLUGS</b> Clean, adjust, and test.	X	X	Group 1 Part 2
<b>ENGINE COMPRESSION</b> Take compression reading of each cylinder.		X	Page 1-13
<b>MANIFOLD</b>			Group 1 Part 1
			Group 1 Part 4

Operation	Perform on		Recommended Procedure
	Minor	Major	
<b>BATTERY</b> Clean battery cables and terminals.		X	Group 7 Part 1
Tighten cable clamps.		X	
Grease battery terminals.		X	
Check battery state of charge.	X	X	
<b>ELECTRICAL</b> Check generator output.		X	Group 7 Part 1
Check starter motor current draw.		X	
Check coil output.		X	Group 1 Part 2
Perform a primary circuit resistance test.		X	



TABLE 2—Tune-Up Schedule (cont'd)

Operation	Perform on		Recommended Procedure
	Minor	Major	
<b>ELECTRICAL (Cont'd)</b> Perform a secondary circuit continuity test.		X	Group 1 Part 2
<b>DISTRIBUTOR</b> Check the condition of the breaker points.	X		Group 1 Part 2
Replace the breaker points and the condenser.		X	
Check and adjust breaker arm spring tension.		X	
Lubricate the distributor cam. Oil the lubricating wick. Lubricate the distributor bushing through the oil cup.		X	
Check and adjust point dwell.	X	X	
Check and adjust centrifugal advance.		X	
Check and adjust vacuum advance.		X	
Clean distributor cap and rotor.	X	X	

Operation	Perform on		Recommended Procedure
	Minor	Major	
<b>FUEL SYSTEM</b> Clean fuel pump filter bowl.	X	X	Group 1 Part 3
Replace fuel pump filter bowl strainer.		X	
Check fuel pump pressure and capacity.		X	
Clean carburetor fuel bowls and adjust float setting.		X	
<b>ADJUSTMENTS</b> Check and adjust ignition timing.	X	X	Group 1 Part 2
Check and adjust engine idle speed.	X	X	Group 1 Part 3
Adjust idle fuel mixture.	X	X	
<b>VACUUM</b> Check manifold vacuum.	X	X	Page 1-13
<b>EXHAUST</b> Free the exhaust gas control valve.	X	X	Group 1 Part 1
<b>COOLING SYSTEM</b> Inspect the radiator, hoses, and engine for leaks.		X	Group 1 Part 4
Add rust inhibitor to radiator.		X	

## 4 TESTS AND ADJUSTMENTS (ENGINE IN CHASSIS)

### CAMSHAFT LOBE LIFT

Remove the valve rocker arm shaft assembly and install a solid tappet-type push rod in the push rod bore of the valve to be checked. Make sure the push rod is in the lifter push rod cup, then install a dial indicator in such a manner as to have the actuating point of the indicator in the push rod socket and in the same plane as the push rod movement (Fig. 12). Rotate the crankshaft slowly in the direction of rotation until the lifter is on the base circle of the camshaft lobe. At this point, the push rod will be in its lowest position. Set the dial indicator on zero, then continue to rotate the damper slowly until the push rod is in the fully raised position. Compare the total lift recorded on the indicator with specifications. Continue to rotate the crankshaft until the indicator reads zero. This later step is a check on the accuracy of the original indicator reading.



**BUY IT NOW!**

[Click Here To Order](#)



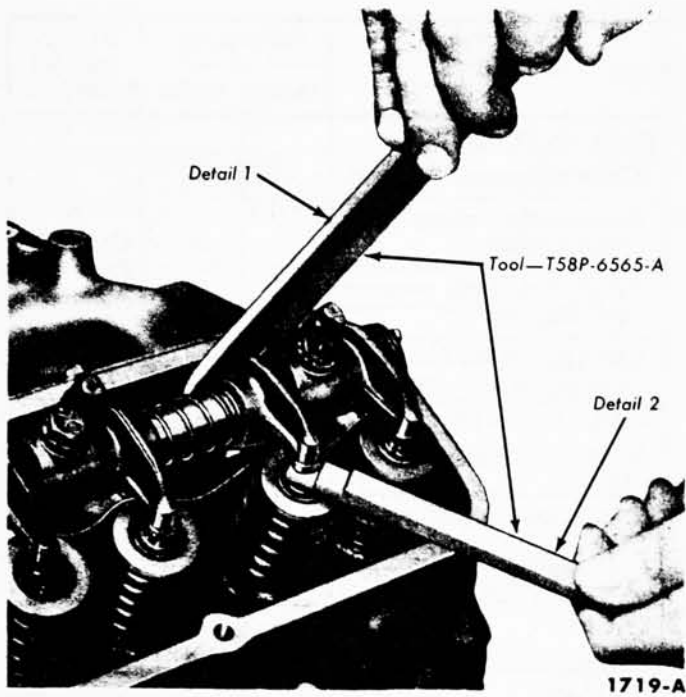

FIG. 13—Valve Clearance

### VALVE TIMING

The valve timing should be checked when poor engine performance is noted and all other checks, such as carburetion, ignition timing, etc. fail to locate the cause of the trouble.

Before the valve timing is checked, check for a bent timing pointer. Bring the No. 1 piston to T.D.C. on the compression stroke and see if the timing pointer is aligned with the T.D.C. mark on the damper.

If the valve timing is not within specifications, check the timing chain, camshaft sprocket, crankshaft sprocket, camshaft, and crankshaft in the order of accessibility.

To check the valve timing with the engine installed, proceed as follows:

Install a quadrant on the crankshaft damper. Remove the right valve rocker arm shaft assembly and remove the No. 1 intake valve push rod (the second push rod) and install a solid tappet-type push rod in its place. Make sure the push rod is in the lifter push rod cup, then install a dial indicator in such a manner as to have the actuating point of the indicator in the push rod socket and the plunger in the push rod cup.

tor and continue turning the crankshaft slowly in the direction of rotation until the dial indicator registers the specified camshaft lobe lift (Table 3).

Compare the crankshaft degrees indicated on the quadrant with specifications (Table 3). After the valve opening is checked, continue to rotate the damper to check the valve closing.

### VALVE CLEARANCE

A 0.060 inch shorter push rod is available for service to provide a means of compensating for dimensional changes in the valve mechanism. Valve stem to rocker arm clearance should be 0.062-0.1875 inch with the hydraulic lifter completely collapsed. Repeated valve reconditioning operations (valve and/or valve seat refacing) will decrease this clearance to the point that if not compensated for, the hydraulic valve lifter would cease to function. To determine whether a shorter push rod is necessary, make the following check:

1. Position the hydraulic lifter compressor tool on the rocker arm and slowly apply pressure to bleed down the hydraulic lifter until the plunger is completely bottomed (Fig. 13). Hold the lifter in the fully collapsed position and insert the clearance gauge (Fig. 13) between the valve

TABLE 3—Valve Timing Specifications

Intake Valve			
Opens		Closes	
Crankshaft Degrees	Camshaft Lobe Lift	Crankshaft Degrees	Camshaft Lobe Lift
21° B.T.C.	0.017	51° A.B.C.	0.019
Exhaust Valve			
Opens		Closes	
Crankshaft Degrees	Camshaft Lobe Lift	Crankshaft Degrees	Camshaft Lobe Lift
67° B.B.C.	0.017	9° A.T.C.	0.019

stem and the rocker arm of the valve being checked. If the first step of the gauge enters, the old push rod may be used. If the first step will not enter, replace the standard push rod with a shorter service push rod. If the second step of the gauge enters, the operating range of the lifter is excessive which indicates that the incorrect push rod has been installed or severe wear has occurred at the push rod ends, rocker arm, or valve stem. In this case, it will be necessary to determine the area of discrepancy and the incorrect or defective part(s) should be replaced. **Before the clearance is checked position the crankshaft as outlined in step 2 and 3.**

2. Rotate the crankshaft until No. 1 piston is on T.D.C. at the end of the compression stroke. With No. 1 piston on T.D.C., check the following valves:

No. 1 Intake	No. 1 Exhaust
No. 3 Intake	No. 4 Exhaust
No. 7 Intake	No. 5 Exhaust
No. 8 Intake	No. 8 Exhaust

3. After these valves have been checked, position No. 6 piston on T.D.C. and check the following valves:

No. 2 Intake	No. 2 Exhaust
No. 4 Intake	No. 3 Exhaust
No. 5 Intake	No. 6 Exhaust
No. 6 Intake	No. 7 Exhaust

**100% SATISFACTION GUARANTEED**

**BUY IT NOW!**

**Click Here To Order**

PayPal | American Express | Discover | MasterCard | VISA

When compressing the valve spring to remove push rods, be sure the piston in the individual cylinder is below T.D.C. to avoid contact between the valve and the piston or serious damage could result.

To replace a push rod, it will be necessary to remove the valve rocker arm shaft assembly as outlined on page 1-16, step 2.

Upon replacement of a valve push rod and/or valve rocker arm shaft assembly, the engine should not be cranked or rotated until the hydraulic lifters have had an opportunity to leak down to their normal operating position. The leak down rate can be accelerated by using the tool shown in Fig. 13 on the valve rocker arm applying pressure in a direction to collapse the lifter.

### MANIFOLD VACUUM TEST

A manifold vacuum test aids in determining the condition of an engine and also in helping to locate the cause of poor engine performance. To test manifold vacuum:

1. Operate the engine for a minimum of ½-hour at 1200 rpm.
2. Install an accurate, sensitive vacuum gauge on the fuel pump end of the fuel pump vacuum line.
3. Operate the engine at recommended idle rpm.
4. Check the vacuum reading on the gauge.

### TEST CONCLUSIONS

Manifold vacuum is affected by carburetor adjustment, valve timing, the condition of the valves, cylinder compression, and leakage of the manifold, carburetor, or cylinder head gaskets.

Because abnormal gauge readings may indicate that more than one of the above factors is at fault, exercise caution in analyzing an abnormal reading. For example, if the vacuum is low, the correction of one item may increase the vacuum enough so as to indicate that the trouble has been corrected. It is important, therefore, that each cause of an abnormal reading be investigated and further tests conducted where necessary in order to arrive at the correct diagnosis of the trouble.

Table 4 lists various types of readings and their possible causes. This

**TABLE 4—Manifold Vacuum Gauge Readings**

Gauge Reading	Engine Condition
19-20 inches.	Normal.
Low and steady.	Loss of power in all cylinders caused possibly by late ignition or valve timing, or loss of compression due to leakage around the piston rings.
Very low.	Manifold, carburetor, or cylinder head gasket leak.
Needle fluctuates steadily as speed increases.	A partial or complete loss of power in one or more cylinders caused by a leaking valve, cylinder head or intake manifold gasket leak, a defect in the ignition system, or a weak valve spring.
Gradual drop in reading at engine idle.	Excessive back pressure in the exhaust system.
Intermittent fluctuation.	An occasional loss of power possibly caused by a defect in the ignition system or a sticking valve.
Slow fluctuation or drifting of the needle.	Improper idle mixture adjustment, carburetor or intake manifold gasket leak, or possibly late valve timing.

### ENGINE COMPRESSION TEST

1. Be sure the battery is good. Operate the engine for a minimum of ½ hour at 1200 rpm. Turn the ignition switch off, then remove all the spark plugs.

2. Set the primary throttle plates and the choke plate in the wide open position.

3. Install a compression gauge in No. 1 cylinder.

4. Crank the engine until the gauge registers a maximum reading and record the reading. Note the number of compression strokes required to obtain the maximum reading.

5. Repeat the test on each cylinder, cranking the engine the same number of strokes for each cylinder as was required to obtain a maximum reading on No. 1 cylinder.

### TEST CONCLUSIONS

A variation of  $\pm 20$  pounds from specified pressure is satisfactory. However, the compression of all cylinders should be uniform within 10 pounds.

A reading of more than 20 pounds

above normal indicates excessive deposits in the cylinder.

A reading of more than 20 pounds below normal indicates leakage at the cylinder head gasket, piston rings, or valves.

A low even compression in two adjacent cylinders indicates a cylinder head gasket leak. This should be checked before condemning the rings or valves.

To determine whether the rings or the valves are at fault, squirt the equivalent of a tablespoon of heavy oil in the combustion chamber, then crank the engine to distribute the oil and repeat the compression test. The oil will temporarily seal leakage past the rings. If approximately the same reading is obtained, the rings are satisfactory, but the valves are leaking. If the compression has increased 10 pounds or more over the original reading, there is leakage past the rings.

During a compression test, if the pressure fails to climb steadily and remains the same during the first two successive strokes, but climbs higher on the succeeding strokes, or fails to climb during the entire test, it indicates a sticking or stuck valve.



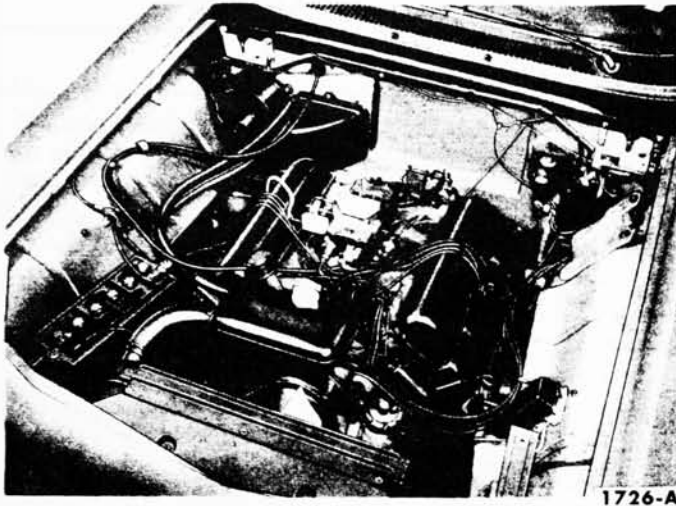

FIG. 14—Engine Installation

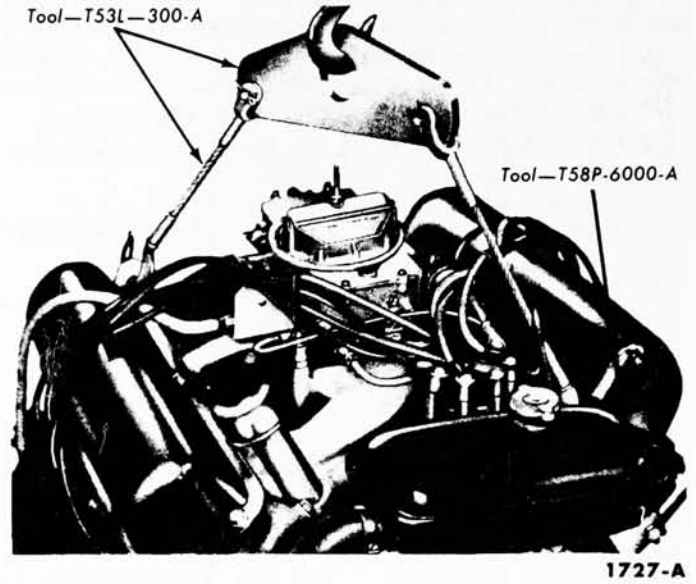

FIG. 15—Engine Lifting Brackets and Sling

## 5 ENGINE REMOVAL AND INSTALLATION

The procedures given are for the engine only without the transmission attached. If the engine and transmission are removed as an assembly, install standard eye bolts with ½-14 threads in the bosses at the top rear of the exhaust manifolds. Then attach the engine lifting bracket and sling to the eye bolts. The engine installation is shown in Fig. 14.

### REMOVAL

1. Drain the cooling system and the crankcase. Disconnect the battery ground cable at the engine. Remove the hood, radiator, and the air cleaner.

2. Remove the oil level dip stick and the coil. Disconnect the oil pressure sending unit wire at the sending unit, the flexible fuel line at the fuel tank line, the flexible windshield wiper line at the vacuum pump and position it out of the way. Remove the wire loom from the clips on the left valve rocker arm cover and position the wires out of the way.

On cars with a windshield washer,

On cars with Cruise-O-Matic disconnect the accelerator rod and the transmission rod at the accelerator cross shaft bracket and secure them to the dash panel.

On cars with power steering, disconnect the power steering pump bracket from the water pump, then wire the power steering pump to the hood left hinge in a position that will prevent the oil from draining out.

On cars with power brakes, disconnect the power brake line at the intake manifold and at the flexible line, then release the line from the brackets on the left valve rocker arm cover and remove the line.

On cars with an air conditioner, disconnect the magnetic clutch wire. Isolate the compressor as outlined in the "1958 Air Conditioner Shop Manual."

3. Disconnect the heater hose at the water pump and at the intake manifold, the generator wires at the generator, and the engine temperature sending unit wire at the sending unit. Remove the engine ground strap and the starter cable retaining bracket from the rear of the right cylinder head.

4. Raise the front of the car. Remove the starter and dust seal (and the Cruise-O-Matic fluid filler tube

bracket). Remove the crankcase ventilation tube. Disconnect the muffler inlet pipes from the exhaust manifolds, the engine right and left support insulators at the engine.

On cars with Cruise-O-Matic, remove the converter housing lower access cover and the cover assembly. Remove the flywheel to converter nuts. Secure the converter assembly in the housing. Remove the converter housing to engine lower bolts, and remove the oil cooler lines retaining clamp from the engine block.

On conventional drive or overdrive units, remove the flywheel housing inspection cover and the clutch pedal retracting spring. Disconnect the clutch release bracket at the equalizer rod and remove the bracket from the engine. Remove the flywheel housing to engine upper bolts.

5. Lower the car, then support the transmission. Remove the converter or flywheel housing upper retaining bolts. Install the engine left lifting bracket on the front of the left cylinder head where the coil mounts, and install the engine right lifting bracket at the rear of the right cylinder head, then attach the engine lifting sling (Fig. 15). Raise the engine slightly and carefully pull it from the transmission. Lift the engine out of the engine compartment

**100% SATISFACTION GUARANTEED**

**BUY IT NOW!**

**Click Here To Order**

dr  
at  
in

PayPal

MasterCard

VISA

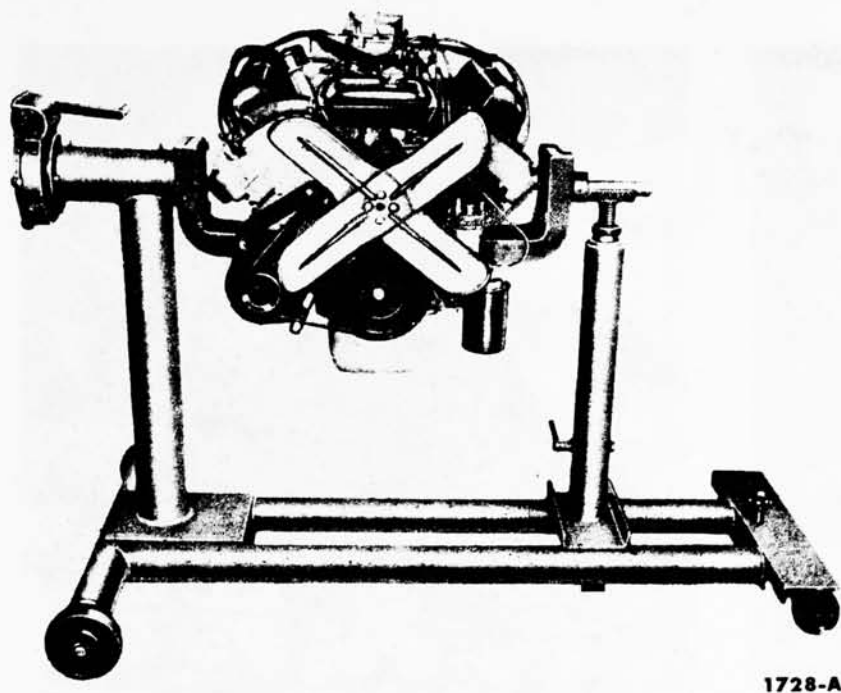

**FIG. 16—Engine Work Stand**

and install it on a work stand (Fig. 16).

### INSTALLATION

1. Position the exhaust gas control valve, with a new gasket on each side, on the right exhaust manifold studs. Temporarily tie the valve to the manifold. Place a new gasket over the studs of the left exhaust manifold. Loosen the engine right and left support insulators at the chassis. Attach the engine lifting brackets and sling (Fig. 15), then remove the engine from the work stand.

2. Lower the engine carefully into the engine compartment. Make sure the exhaust manifolds are properly aligned with the muffler inlet pipes and the dowels in the block engage the holes in the flywheel housing or converter housing.

On cars with Cruise-O-Matic, start the converter pilot into the crankshaft.

On conventional drive or overdrive units, start the transmission main gear into the clutch disc. It may

**gear) until the shaft splines mesh with the clutch disc splines.**

3. Install the crankcase ventilation tube and the flywheel housing or converter housing upper bolts, then tighten the bolts to 45-50 foot-pounds torque.

4. Start the engine right and left support insulator to engine bolts. Disconnect the engine lifting sling and remove the lifting brackets.

5. Raise the front of the car. Install the flywheel housing or converter housing lower retaining bolts and tighten them to 45-50 foot-pounds torque.

On cars with Cruise-O-Matic remove the retainer securing the converter in the housing, then install the flywheel to converter lockwashers and nuts. Tighten the nuts to 25-28 foot-pounds torque. Install the converter lower access plate and the housing cover assembly. Install the oil cooler lines retaining clamp.

On conventional drive or overdrive units, install the clutch bracket. Connect the clutch release rod and install the clutch retracting spring. Install the flywheel housing lower cover.

6. Tighten all the engine front support insulator bolts and nuts to 45-50 foot-pounds torque. Remove the re-

tainer securing the exhaust gas control valve, then connect both exhaust manifolds to the muffler inlet pipes and tighten the nuts to 23-28 foot-pounds torque. Position the dust seal and install the starter (and the automatic transmission fluid filler tube bracket).

Remove the support from the transmission and lower the car.

7. Connect the generator wires, the engine temperature sending unit wire, and connect the heater hose at the intake manifold. Connect the engine ground strap and install the starter cable retaining clamp to the rear of the right cylinder head.

8. Connect the flexible fuel line, the oil pressure sending unit wire, and the windshield wiper vacuum line. Install the coil and connect the coil primary and high tension wires. Install the oil level dipstick. Position the wire loom in the retaining clips on the left valve rocker arm cover.

On cars with a windshield washer, connect the three washer pump lines.

On cars with Cruise-O-Matic, connect the accelerator rod and the transmission rod.

On conventional drive and overdrive units, install the accelerator retracting spring. Connect the accelerator rod.

On cars with power steering, connect the power steering pump bracket to the water pump.

On cars with power brakes, connect the power brake line to the intake manifold and to the flexible line and install the line in the retaining clips on the left valve rocker arm cover.

On cars with an air conditioner, connect the magnetic clutch wire and the compressor lines.

9. Install the radiator. Fill and bleed the cooling system. Connect the heater hose at the water pump. Fill the crankcase with the proper grade and quantity of engine oil. Operate the engine at fast idle and check all gaskets and hose connections for leaks. Install the air cleaner.

**100% SATISFACTION GUARANTEED**

**BUY IT NOW!**

**Click Here To Order**

PayPal    American Express    Discover    MasterCard    VISA

## 6 ENGINE DISASSEMBLY AND ASSEMBLY (ENGINE REMOVED FROM CHASSIS)

### ENGINE DISASSEMBLY

#### INTAKE MANIFOLD

1. Disconnect the wires at the spark plugs and remove the wires from the ignition harness brackets on the valve rocker arm covers. Remove the distributor cap assembly. Disconnect the distributor vacuum line at the distributor. Remove the carburetor fuel inlet line, the vacuum pump lines, then remove the fuel pump and discard the gasket. Remove the radiator supply tank. Slide the clamp on the water pump bypass hose toward the water pump. Remove the automatic choke heat tube. Remove the valve rocker arm covers.

2. Crank the engine until the No. 1 piston is at T.D.C. at the end of the compression stroke. Rotate the crankshaft damper an additional 45° (indicated on the damper by the symbol XX). Starting at the No. 4 cylinder, loosen the right valve rocker arm shaft support bolts in sequence, two turns at a time. After the bolts are all loosened, remove the valve rocker arm shaft assembly and the oil baffle plate. Starting at the No. 5 cylinder, follow the same procedure on the left valve rocker arm shaft support bolts. **This procedure must be followed to avoid damage to the valve mechanism.** Remove the valve push rods in sequence.

3. Remove the distributor hold down bolt and clamp and remove the distributor. Remove the 10 intake manifold retaining bolts. Install standard eye bolts with 3/16-18 threads in the left front and right rear rocker arm cover screw holes and attach the engine lifting sling (Fig. 17). Raise the manifold and carefully remove it from the engine. Remove the intake manifold gaskets and seals.

4. Remove the hydraulic valve lifters from the cylinder block and place

If the hydraulic lifters can not be removed with the fingers, remove the lock ring (Fig. 18), and the push rod cup (Fig. 19), and remove the lifter and plunger assembly with the tool shown in Fig. 20. After the lifter is removed, keep all the parts together so as not to intermix the parts.

#### EXHAUST MANIFOLD AND EXHAUST GAS CONTROL VALVE

Remove the exhaust manifold lower retaining bolts and tab washers and remove the exhaust manifolds.

Remove the exhaust gas control valve from the right exhaust manifold.

#### CYLINDER HEADS

Remove the cylinder head bolts, then install the cylinder head holding fixture (Fig. 21). Lift the cylinder head off the block. **Do not pry between the head and the block.** Remove and discard the cylinder head gasket.

#### OIL FILTER AND ADAPTER

Unscrew the oil filter from the adapter. Remove the oil filter adapter assembly and oil pressure sending unit as an assembly. Discard the gasket.

#### OIL PAN AND OIL PUMP

1. Remove the oil pan retaining screws and remove the oil pan. Discard the gasket.

2. Remove the oil pump attaching

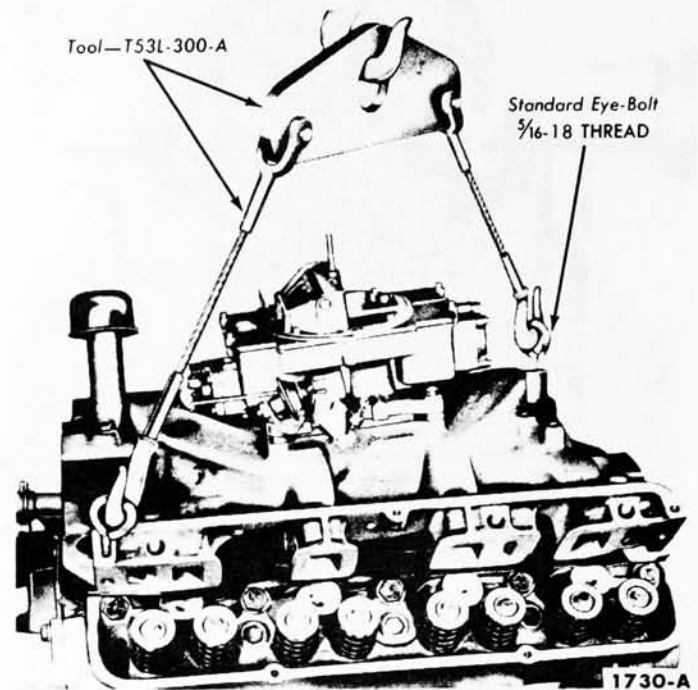

FIG. 17—Intake Manifold Removal or Installation

bolts and remove the oil pump and inlet tube as an assembly, and remove the oil pump drive shaft. Discard the oil pump gasket.

#### CYLINDER FRONT COVER

1. Remove the fuel pump and discard the gasket. Disconnect the drive belt adjusting arm at the generator. Remove the generator support bolt at the water pump and the bracket bolt at the cylinder block. Remove the generator, brackets, and drive belts. Remove the water pump, pulley, and fan as an assembly.

2. On cars with power steering, remove the two cap screws and lock-washers securing the power steering pulley to the crankshaft damper, then remove the pulley.

Remove the large cap screw and washer from the end of the crankshaft. Install the puller on the crankshaft damper (Fig. 22) and remove the damper.

3. If the crankshaft sleeve is not stepped down (the same O.D. on both ends), remove it as shown in Fig. 23. If the crankshaft sleeve is stepped down (different O.D. on each end), remove it with a three-jawed puller (Tool 7675-N).

4. Remove the screws fastening the cylinder front cover to the block, then remove the cylinder front cover.

5. Discard the cylinder front cover gasket.

**100% SATISFACTION GUARANTEED**

**BUY IT NOW!**

**Click Here To Order**

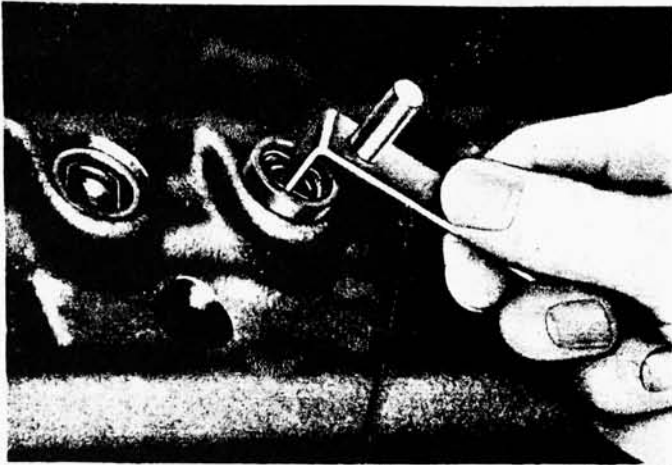

Tool—HL1 1731-A

FIG. 18—Lock Ring Removal



Tool—HL1 1732-A

FIG. 19—Push Rod Cup Removal



Tool—HL1 VALVE LIFTER RACK 1733-A

FIG. 20—Hydraulic Valve Lifter Removal

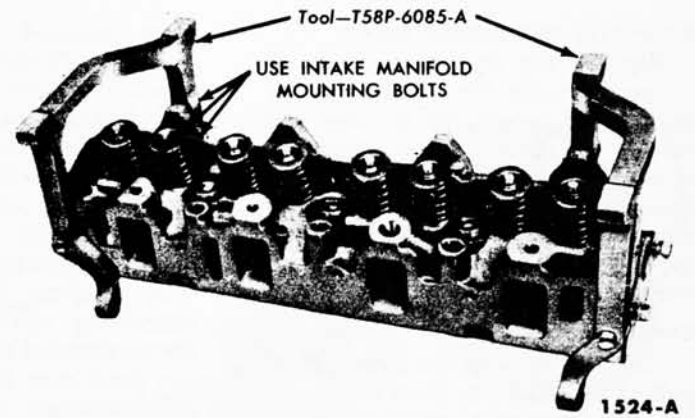

1524-A

FIG. 21—Cylinder Head Holding Fixture



Tool—T58P-6316-A 1551-B



Crankshaft Sleeve Tool—T56P-6362-A 1552-B

FIG. 23—Crankshaft Sleeve Removal

**100% SATISFACTION GUARANTEED**

**BUY IT NOW!**

**Click Here To Order**

PayPal American Express Discover Novus MasterCard VISA



**FIG. 24—Timing Chain and Sprockets Removal or Installation**

#### SPROCKETS AND TIMING CHAIN

Remove the crankshaft front oil slinger. Remove the camshaft thrust button and spring, the sprocket cap screw, the thrust button spring retainer, and the fuel pump eccentric. Slide both sprockets and the timing chain forward, and remove the sprockets and timing chain as an assembly (Fig. 24).

#### CAMSHAFT

Carefully remove the camshaft by pulling it toward the front of the engine. Use caution to avoid damaging the journals and lobes.

#### FLYWHEEL

1. On conventional flywheels, mark the pressure plate cover so that it can be replaced in the same position, and remove the clutch pressure plate and disc.

2. Remove the flywheel retaining bolts and remove the flywheel.

#### CRANKSHAFT AND CONNECTING ROD ASSEMBLIES

1. Remove any ridge and/or carbon deposits from the upper end of the cylinder bores. Move the piston to the bottom of its travel and place

been removed, remove the cutter from the cylinder bore, then turn the crankshaft until the piston is at the top of its stroke and carefully remove the cloth with the cuttings.

2. Make sure all bearing caps (main and connecting rod) are marked so they can be installed in their original locations.

3. Turn the crankshaft until the connecting rod being removed is down. Remove the pal nuts and the hex head nuts from the connecting rod bolts, then pull the cap off the rod. Push the connecting rod and piston assembly out the top of the cylinder with the handle end of a hammer. **Avoid damage to the crankpin or the cylinder wall when removing the piston and rod.** Remove the bearing inserts from the connecting rods and caps.

4. Remove the main bearing caps. Carefully lift the crankshaft out of the cylinder block so that the thrust bearing surfaces are not damaged. **Handle the crankshaft with care to avoid possible fracture or damage to the finished surfaces.** Remove the rear journal oil seal from the block and rear bearing cap, and remove the cap to block side seals. Remove the main bearing inserts from the block and bearing caps.

#### CAMSHAFT BEARINGS

Drill a 1/2-inch hole in the camshaft rear bearing bore plug and use

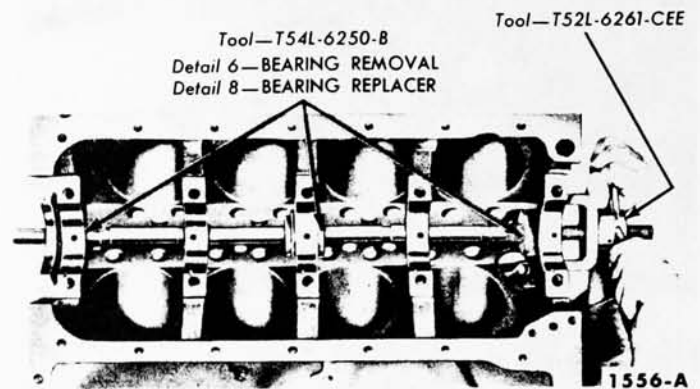

**FIG. 25—Camshaft Bearing Replacement**

Tool T-7600-E to remove the plug. Remove the camshaft bearings (Fig. 25).

#### ENGINE ASSEMBLY CAMSHAFT BEARINGS

Camshaft bearings are available pre-finished to size for standard and 0.015-inch undersize journal diameters. The bearings are not interchangeable from one bore to another. The bearings must be installed in their respective bores.

1. Position the new bearing at the bearing bore, and press it in place with the tool shown in Fig. 25. Align the oil holes in the bearings with the oil holes in the cylinder block when the bearings are installed. **Be sure the camshaft front bearing is installed 0.005-0.020 inch below the front face of the cylinder block (Fig. 26).**

2. Clean out the camshaft rear bearing bore plug recess thoroughly. Coat the flange of a new plug with water resistant sealer and install it with the flange facing in (Fig. 27). Drive the plug in until it is flush or slightly below the casting surface.

#### MAIN BEARINGS, REAR JOURNAL OIL SEALS, AND CRANKSHAFT

The crankshaft and related parts are shown in Fig. 28.

1. Be sure that all bearings, crankshaft journals, and the rear journal oil seal grooves are clean. Install a new rear journal oil seal in the block

**100% SATISFACTION GUARANTEED**

**BUY IT NOW!**

**Click Here To Order**

PayPal, American Express, Discover, MasterCard, VISA

INSTALL FRONT BEARING 0.005-0.020-INCH  
BELOW FRONT FACE OF BLOCK

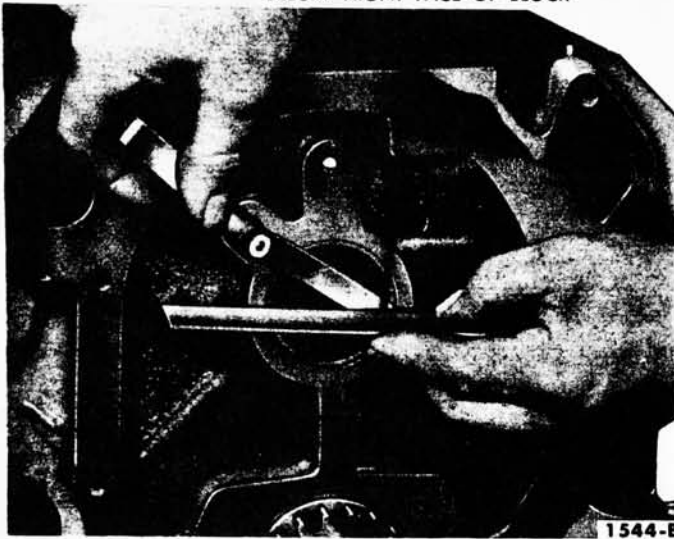

1544-B

FIG. 26—Camshaft Front Bearing Measurement



Tool—T58P-6266-A

1545-A

FIG. 27—Camshaft Rear Bearing Bore Plug Installation

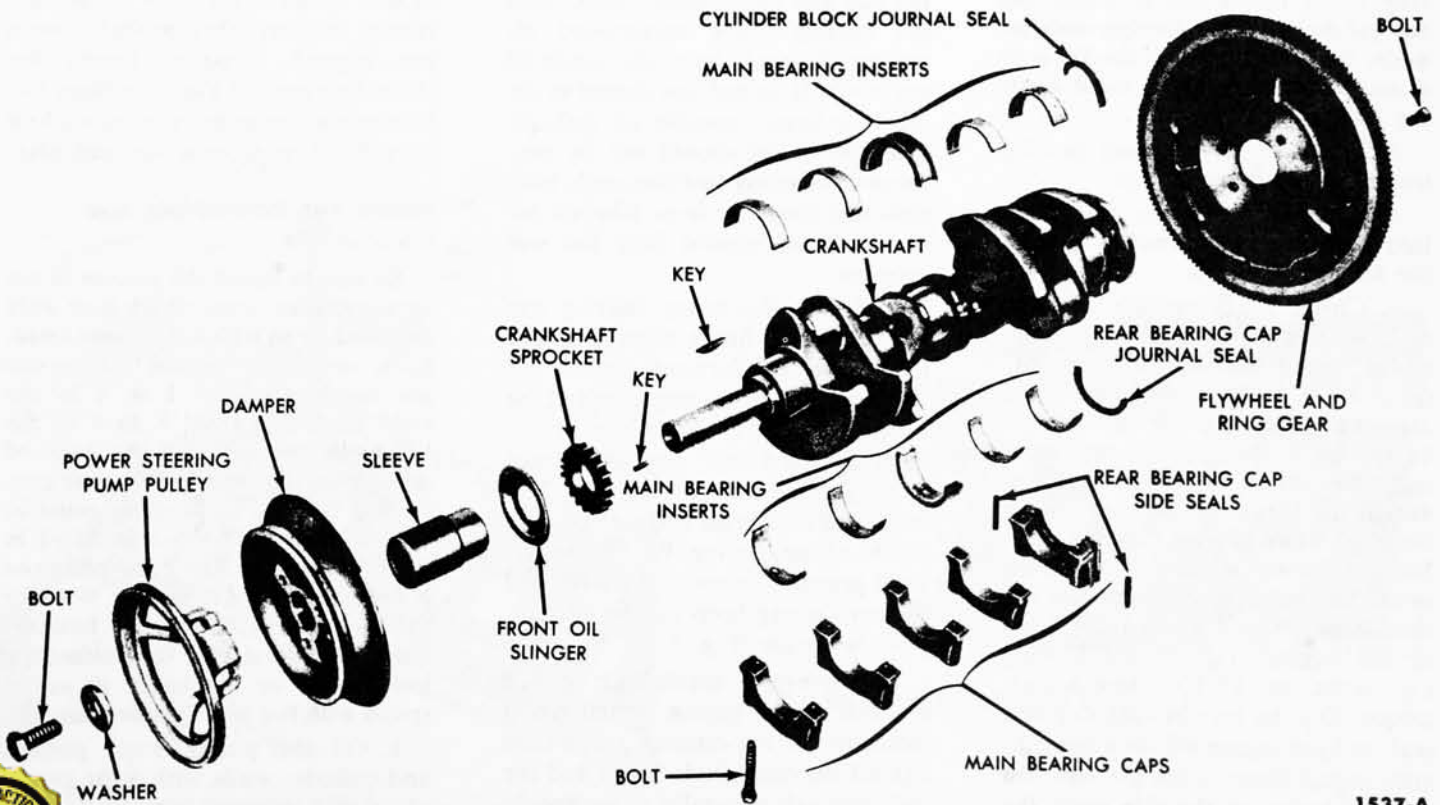

1537-A



**BUY IT NOW!**

**Click Here To Order**



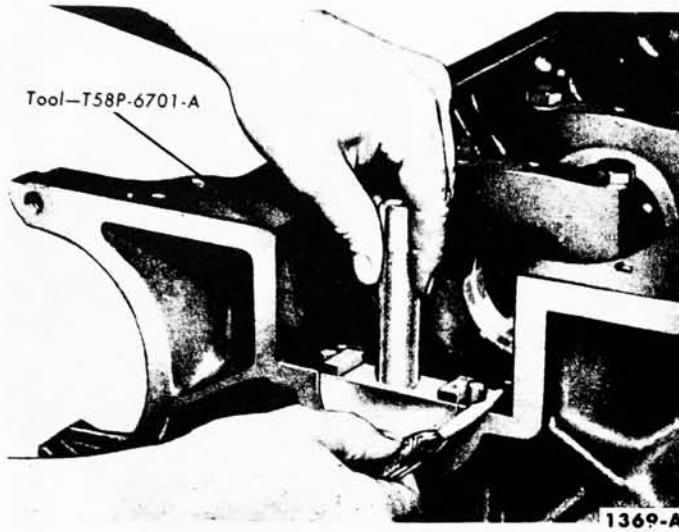

**FIG. 29—Seal to Block Installation**

(Fig. 29) and rear main bearing cap (Fig. 30). After installation, cut the ends of the seals flush.

2. If the crankshaft main bearing journals have been ground to a definite undersize, install the correct undersize bearings.

Place the upper main bearing inserts in position in the bore with the tang fitting in the slot provided. **Do not get dirt or other foreign material under the inserts. In time the dirt may distort the bearing and cause bearing failure.**

3. Install the lower main bearing inserts in the bearing caps.

4. Carefully lower the crankshaft into place. **Be careful not to damage the bearing surfaces.**

5. Check the clearance of each main bearing following the procedure under "Main Bearing Replacement" (page 1-37). If the bearing clearances are satisfactory, apply a light coat of engine oil to the journals and bearings, then install all the bearing caps, except the thrust bearing cap (No. 3 bearing). **Main bearing caps are numbered 1 thru 5 starting at the front of the engine. The arrows on the cap should be pointed toward the front of the engine.** Tighten the bearing cap bolts to 95-105 foot-pounds torque. Dip the rear bearing cap side seals in light engine oil, then immediately install them in the grooves. **Do not oil the side seals the**

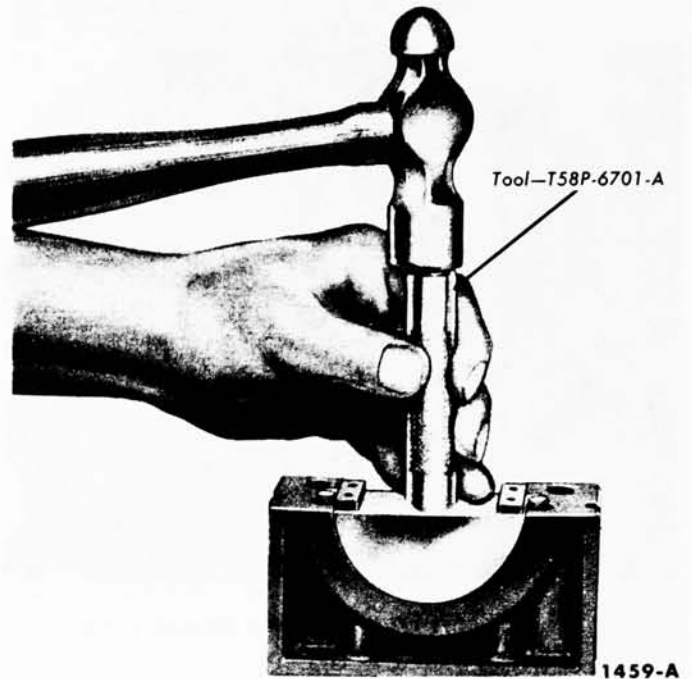

**FIG. 30—Seal to Rear Bearing Cap Installation**

main bearing cap side seals for leaks by squirting a few drops of oil into the parting lines between the bearing cap and the cylinder block from the outside. Blow compressed air against the seals from the inside of the block. If air bubbles appear in the oil, it indicates possible oil leakage. **The above test should not be performed on newly installed seals until sufficient time has been allowed for the seals to expand into the seal grooves.**

6. Install the thrust bearing cap with the bolts finger tight, then pry the crankshaft forward against the thrust surface of the upper half of the bearing (Fig. 31). Hold the crankshaft forward and pry the thrust bearing cap to the rear (Fig. 32). This will align the thrust surfaces of both halves of the bearing. Retain the forward pressure on the crankshaft, and tighten the cap bolts to 95-105 foot-pounds torque (Fig. 33).

7. Force the crankshaft toward the rear of the engine. Install a dial indicator so the contact point rests against the crankshaft flange and the indicator axis is parallel to the crankshaft axis (Fig. 34). Set the dial on zero, then push the crankshaft forward and note the reading on the dial.

If the end play exceeds the wear limit, replace the thrust bearing. If

the end play is less than the minimum limit, inspect the thrust bearing faces for scratches, burrs, nicks, or dirt. If the thrust faces are not defective or dirty, they probably were not aligned properly. Install the thrust bearing and align the faces following the recommended procedure (step 6), then recheck the end play.

#### PISTON AND CONNECTING ROD INSTALLATION

**Be sure to install the pistons in the same cylinders from which they were removed, or to which they were fitted. Each connecting rod and bearing cap are numbered from 1 to 4 in the right bank and from 5 to 8 in the left bank, beginning at the front of the engine. The numbers on the connecting rod and bearing cap must be on the same side when installed in the cylinder bore. If a connecting rod is ever transposed from one block or cylinder to another, new bearings should be fitted and the connecting rod should be numbered to correspond with the new cylinder number.**

1. Oil the piston rings, pistons, and cylinder walls with light engine oil.

2. Make sure the ring gaps are properly spaced around the circumference of the piston. Install a piston ring compressor on the piston and push the piston in with a hammer handle until it is slightly below the

**100% SATISFACTION GUARANTEED**

**BUY IT NOW!**

**Click Here To Order**

PayPal | American Express | Discover | MasterCard | VISA

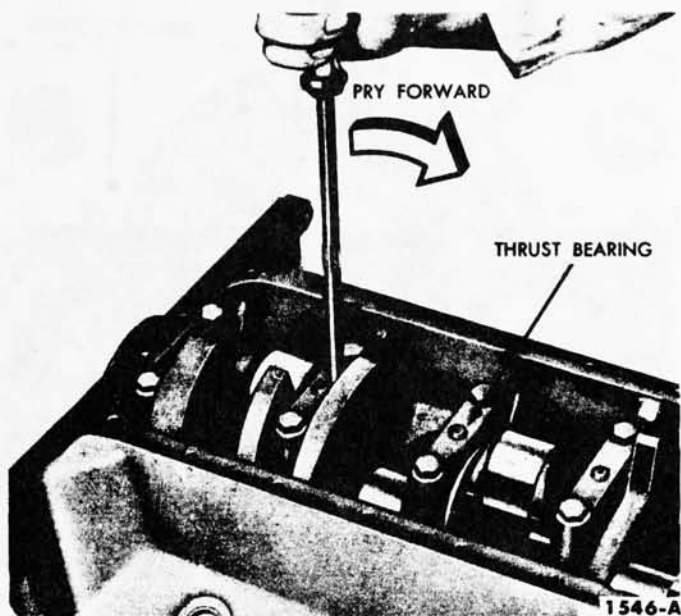

FIG. 31—Thrust Bearing Alignment—Pry Crankshaft Forward

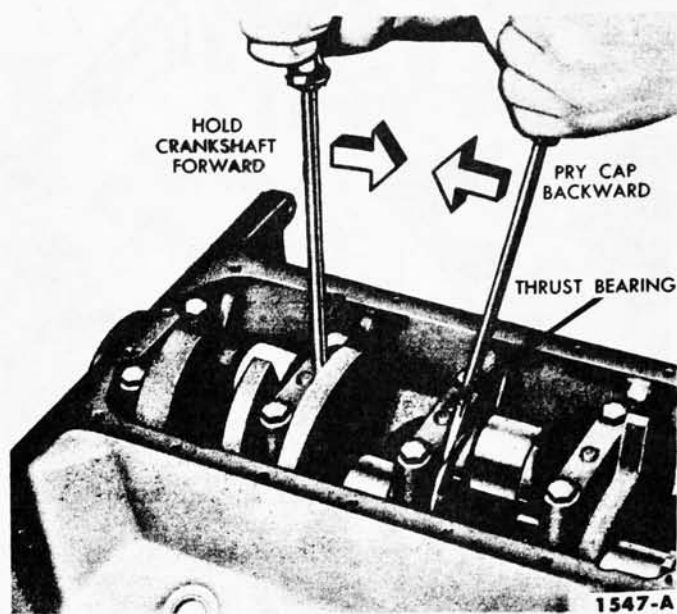

FIG. 32—Thrust Bearing Alignment—Pry Cap Backward

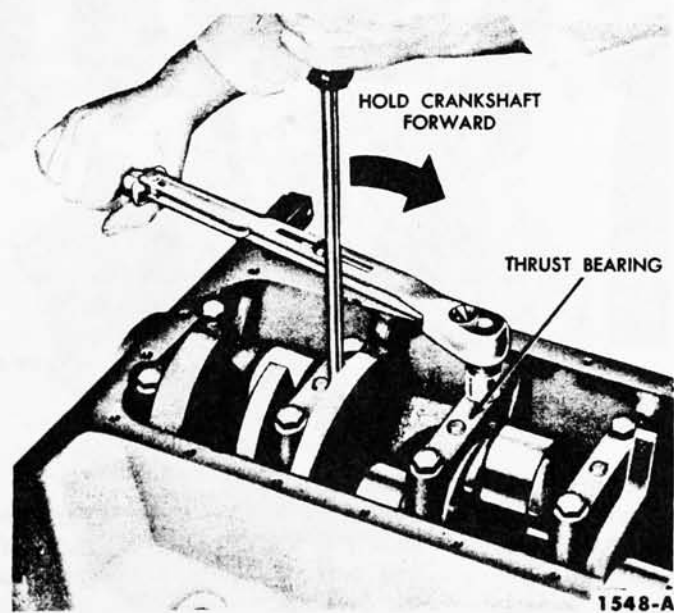

FIG. 33—Thrust Bearing Alignment—Tighten Cap

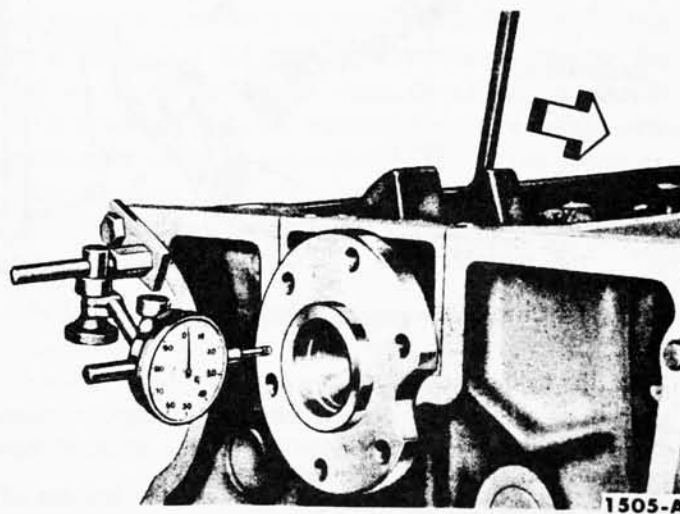

FIG. 34—Crankshaft End Play

**100% SATISFACTION GUARANTEED**

**BUY IT NOW!**

**Click Here To Order**

PayPal   American Express   Discover   MasterCard   VISA



FIG. 35—Piston Installation

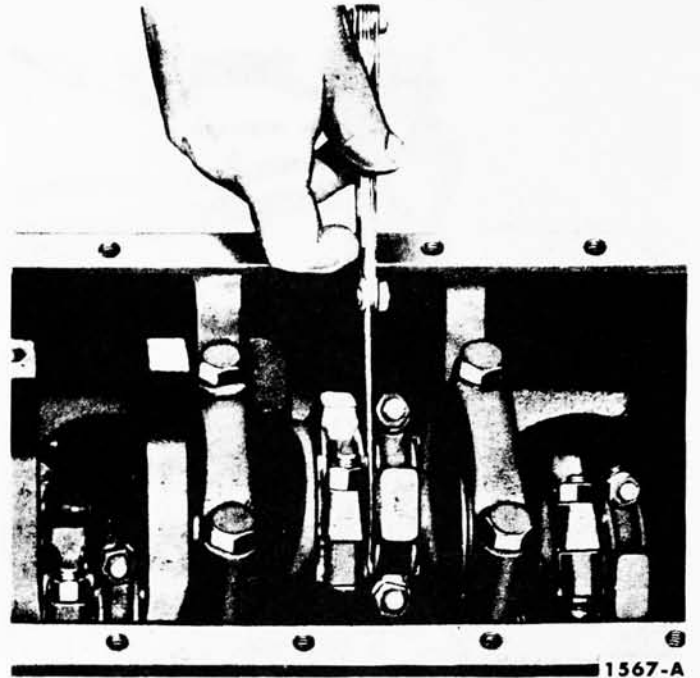

FIG. 36—Connecting Rod Side Clearance

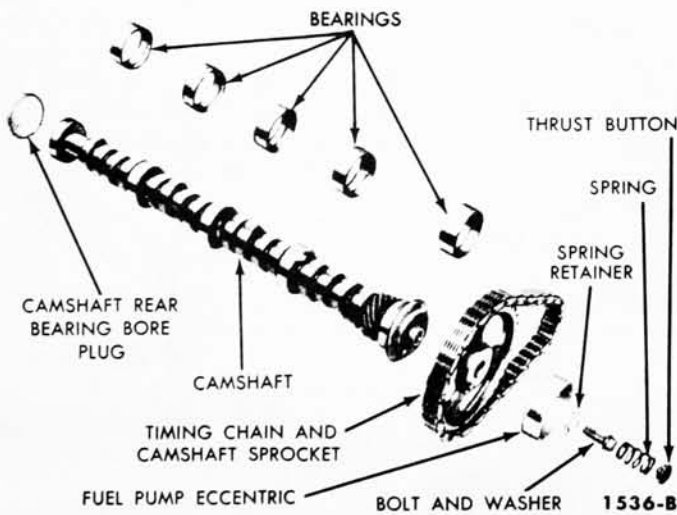

FIG. 37—Camshaft and Related Parts



FIG. 38—Aligning Timing Marks

top of the cylinder (Fig. 35). Be sure to guide the connecting rods to avoid damaging the crankshaft journals. Install the piston with the indentation in the piston head toward the front of the engine. When installed, the bearing lock slots in the connecting rod should be toward the outside of the engine.

the bottom of its stroke, then push the piston all the way down until the connecting rod bearing seats on the crankshaft journal. Install the connecting rod cap, then tighten the nuts to 45-50 foot-pounds torque. Install the pal nuts and tighten them to 3-4 foot-pounds torque.

**CAMSHAFT**

The camshaft and related parts are shown in Fig. 37. Oil the camshaft and carefully slide it through the bearings.

**TIMING CHAIN AND SPROCKETS**

1. Place the keys in position in the slots on the crankshaft and camshaft.
2. Position the sprockets and timing chain on the camshaft and crankshaft (Fig. 24). Be sure the timing marks on the sprockets and chain are positioned as shown in Fig. 38.

5. After the piston and connecting rod assemblies have been installed, check the side clearance between the connecting rods on each crankshaft journal (Fig. 36).

**100% SATISFACTION GUARANTEED**

**BUY IT NOW!**

**Click Here To Order**

PayPal, American Express, Discover, MasterCard, VISA



TAKE UP SLACK ON LEFT SIDE. ESTABLISH A REFERENCE POINT AND MEASURE DISTANCE A. TAKE UP SLACK ON RIGHT SIDE AND FORCE LEFT SIDE OUT WITH THE FINGERS AND MEASURE DISTANCE B. DEFLECTION IS A MINUS B.

1511-B

FIG. 39—Timing Chain Deflection



CRANKSHAFT FRONT OIL SLINGER

1540-B

FIG. 40—Fuel Pump Eccentric and Front Oil Slinger Installed

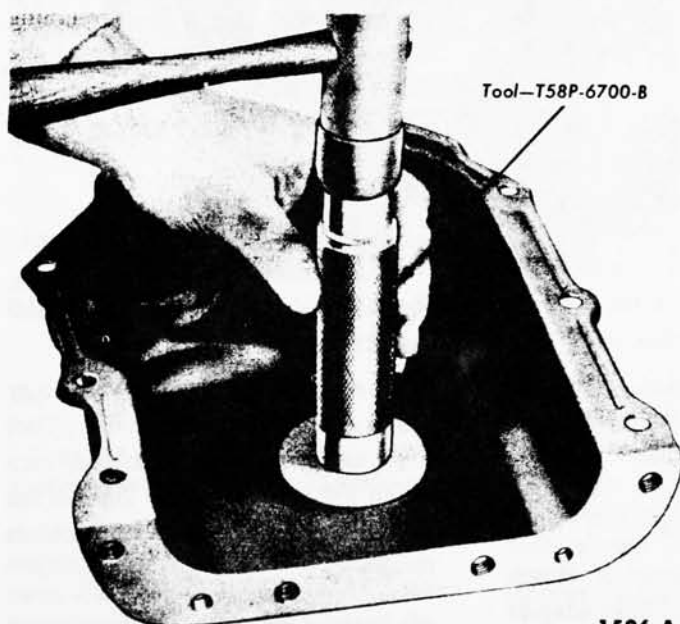

1526-A

3. Rotate the crankshaft in a clockwise direction (as viewed from the front) to take up the slack on the left side of the chain. Establish a reference point on the block and measure from this point to the chain (Fig. 39). Rotate the crankshaft in the opposite direction to take up the slack on the right side of the chain, then force the left side of the chain out with the fingers and measure the distance between the reference point and the chain. The deflection is the difference between the two measurements. If the deflection exceeds  $\frac{1}{2}$  inch, replace the timing chain and/or sprockets.

4. Install the fuel pump eccentric (Fig. 40), and the camshaft sprocket cap screw and thrust button spring retainer. Tighten the sprocket cap screw to 35-45 foot-pounds torque. Install the camshaft thrust button spring and thrust button. Install the crankshaft front oil slinger.

#### CYLINDER FRONT COVER AND FRONT OIL SEAL

**Oil Seal Replacement.** It is good practice to replace the oil seal each time the cylinder front cover is removed.

1. Drive out the old seal with a pin punch, then clean out the recess in the cover.

2. Coat a new seal with grease, then install the seal (Fig. 41). Drive the seal in until it is fully seated in the recess. Check the seal after installation to be sure the spring is properly positioned in the seal.

100% SATISFACTION GUARANTEED

**BUY IT NOW!**

Click Here To Order

PayPal

MasterCard

DISCOVER

MasterCard

VISA

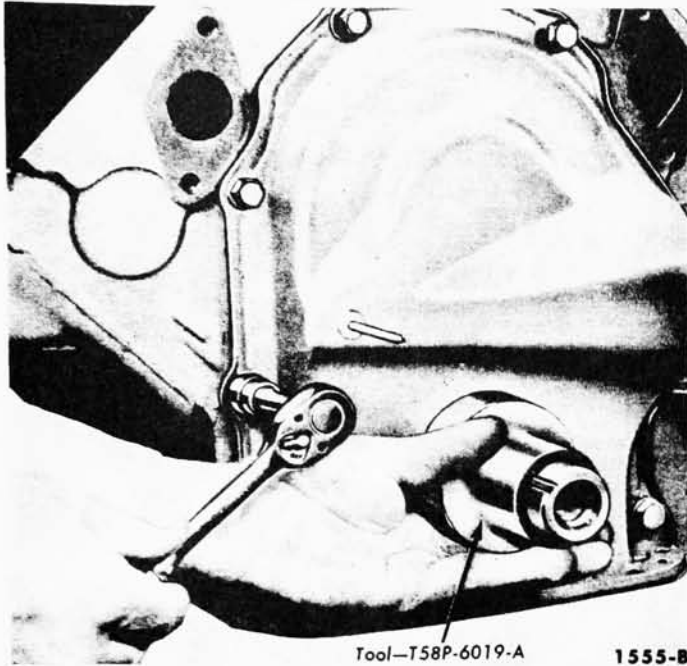

**FIG. 42—Cylinder Front Cover Alignment**

#### Cylinder Front Cover Installation

1. Clean the cylinder front cover and the cylinder block gasket surfaces. Coat the gasket surface of the block and cover and the cover bolt threads with sealer. Position a new gasket on the block.

2. Install the cylinder front cover alignment pilot tool on the cylinder front cover so the keyway in the pilot aligns with the key in the crankshaft. Position the cover and pilot over the end of the crankshaft and against the block (Fig. 42).

3. Install the cylinder front cover bolts finger tight. Position the generator support bracket and the generator adjusting arm bracket, then install the bolts.

While pushing in on the pilot, tighten the cover bolts to 12-15 foot-pounds torque. Remove the pilot.

4. Lubricate the crankshaft with a white lead and oil mixture and lubricate the oil seal rubbing surface

crankshaft, then install the damper on the crankshaft (Fig. 44).

5. Install the damper cap screw and washer, and tighten it to 130-145 foot-pounds torque.

On cars with a separate power steering pulley, install the pulley on the crankshaft damper. Tighten the screws to 23-28 foot-pounds torque.

6. Clean the water pump gasket surfaces and apply sealer. Position new gaskets on the pump and install the water pump, pulley, and fan as an assembly.

On cars with power steering, the power steering pump is retained by the water pump retaining bolts.

7. Using a new gasket, install the fuel pump. Install the generator, brackets, and drive belts.

#### OIL FILTER AND ADAPTER

The oil filter assembly is shown in Fig. 45. Clean the oil filter adapter gasket surfaces. Apply sealer to a new adapter gasket, and install the adapter assembly and gasket. Clean the adapter filter recess. Coat the gasket on a new filter with oil, then place the filter in position on the adapter. Hand tighten the filter until

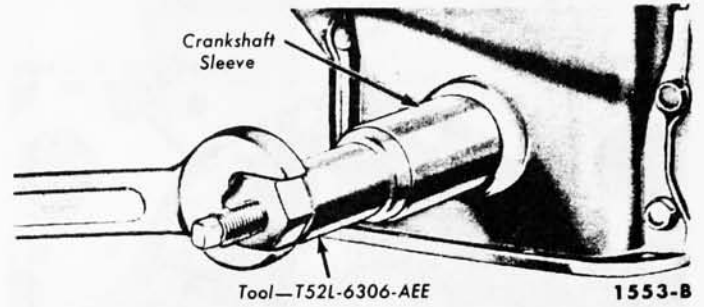

**FIG. 43—Crankshaft Sleeve Installation**

the gasket contacts the adapter face, then advance it  $\frac{1}{2}$ -turn.

#### OIL PUMP AND OIL PAN

1. Insert the oil pump drive shaft into the oil pump. Position a new gasket on the pump housing and install the pump and shaft as an assembly (Fig. 46). **Do not attempt to force the pump into position if it will not seat readily. The drive shaft hex may be misaligned with the distributor shaft. To align, rotate the intermediate shaft into a new position.** Tighten the oil pump retaining screws to 23-28 foot-pounds torque.

2. Position a new gasket on the oil pan and place the oil pan assembly on the block. Install the retaining screws and tighten them from the center outward to 12-15 foot-pounds torque.

#### FLYWHEEL

Position the flywheel on the crankshaft and install the retaining bolts. Tighten the bolts to 75-85 foot-pounds torque.

On cars with conventional drive or overdrive transmissions, use Tool 7563 to locate the clutch disc, then install the pressure plate. Tighten the retaining bolts to 23-28 foot-pounds torque.

#### CYLINDER HEAD

1. Clean carbon deposits and gasket sealer residue from the cylinder head and block gasket surfaces. Apply a coating of head gasket sealer to both sides of a new head gasket. Use the brush furnished to spread

**100% SATISFACTION GUARANTEED**

**BUY IT NOW!**

**Click Here To Order**

PayPal | American Express | Discover | MasterCard | VISA

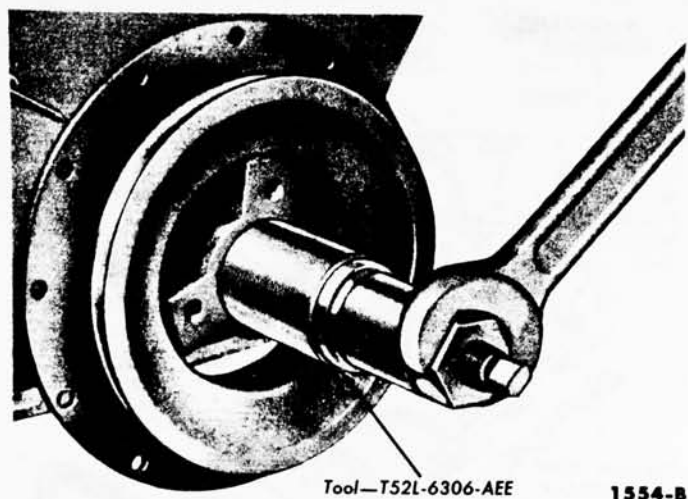

FIG. 44—Crankshaft Damper Installation

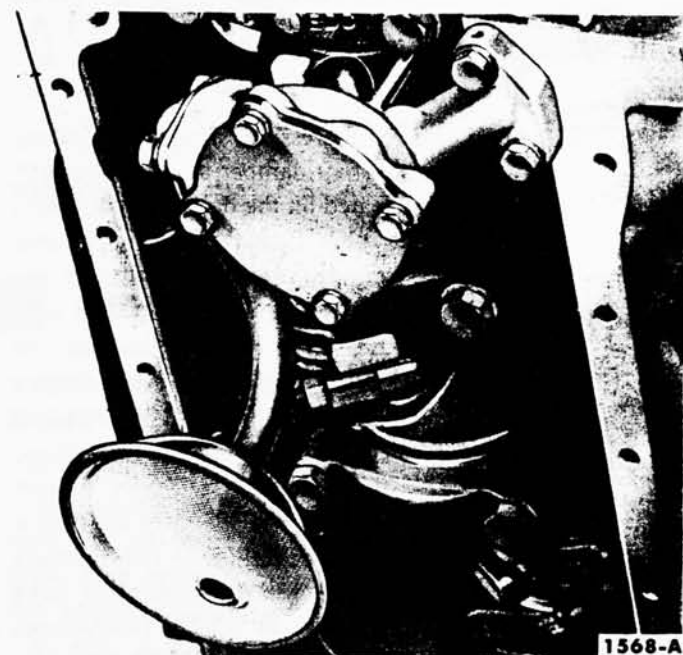

FIG. 46—Oil Pump and Inlet Tube Installed

the sealer evenly over the entire gasket surface. Guided by the word "front" on the gasket, install the head gasket over the cylinder head dowels.

2. Place the cylinder head on the engine, then remove the holding fixtures. Coat the head bolt threads with water resistant sealer, then install the

torque in the same sequence. Finally, tighten the bolts to 80-90 foot-pounds torque in the same sequence. **After the cylinder head bolts have been tightened to specifications, the bolts should not be disturbed.**

#### EXHAUST MANIFOLDS

1. Coat the mating surfaces of the exhaust manifold with a light film of graphite grease.

On the right exhaust manifold, using a new gasket install the automatic choke air chamber cover on the manifold. **Be sure the cover is securely fastened.** Position the ex-

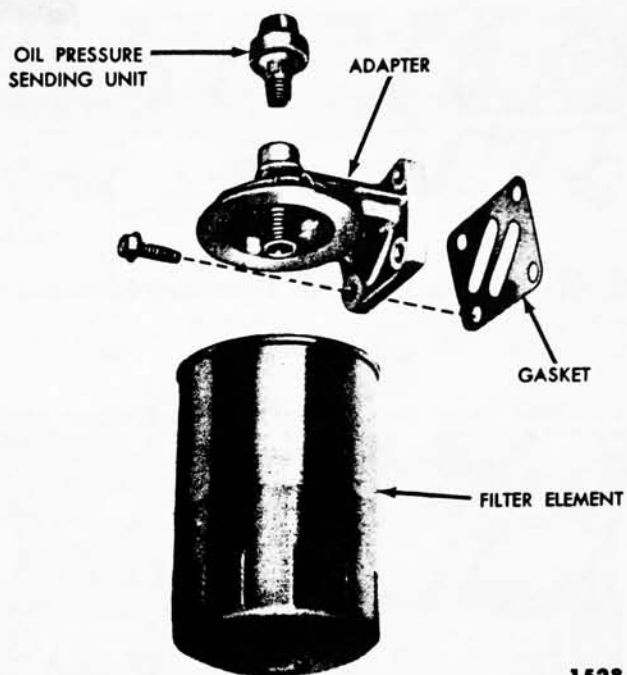

FIG. 45—Oil Filter Assembly

haust gas control valve over the muffler inlet pipe studs of the manifold, using a new gasket on each side of the valve. Temporarily tie the valve to the exhaust manifold.

Position a new gasket over the muffler inlet pipe studs of the left exhaust manifold.

2. Position the exhaust manifold on the cylinder head and install the retaining bolts and tab washers. Tighten the retaining bolts to 23-28 foot-pounds torque, working from the center to the ends. Lock the bolts by bending one tab of the washer over a flat on the bolt.

#### INTAKE MANIFOLD

The intake manifold assembly is shown in Fig. 48.

1. Coat the outside of each hydraulic valve lifter with engine oil to provide initial lubrication. **Do not fill the lifters with oil. The lifters will fill much faster after the engine is started, if they are free of any oil film which may cause an oil seal between the plunger and lifter body.** Place each lifter in the bore from which it was removed.

2. Clean the mating surfaces of the intake manifold, cylinder heads,



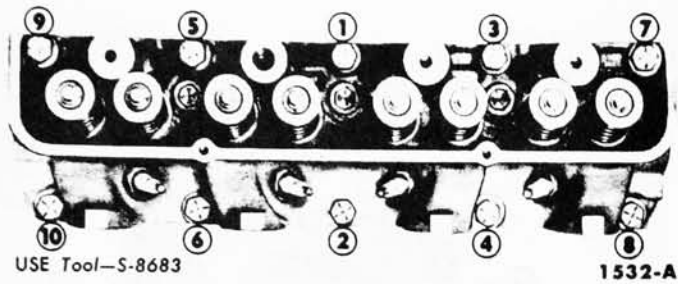

FIG. 47—Cylinder Head Bolt Tightening Sequence

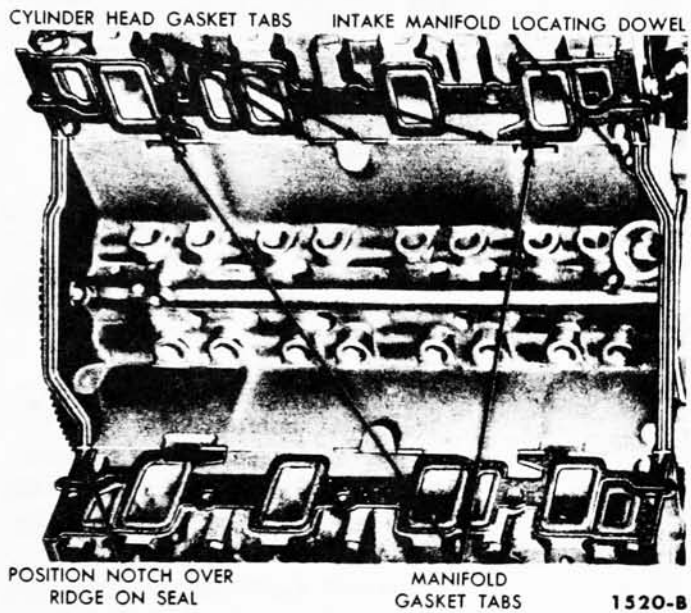

FIG. 49—Intake Manifold Gasket Installation

and cylinder block. Coat the intake manifold and cylinder block neoprene seal surfaces with oil resistant sealer. Position new seals on the cylinder block and new gaskets on the cylinder heads with the gasket resting on the cylinder head gasket tabs. Be sure the holes in the gaskets are aligned with the holes in the cylinder heads. To keep the neoprene seals in place while the intake manifold is being positioned, secure the seals with tape placed in each corner of the outside edge of the seal surface. The correct installation of the gasket seals is shown in Fig. 49.

After the intake manifold is in place, run a finger around the neoprene seal area to make sure the seals are in place. If the seals are not in place, remove the intake manifold and reposition the seals. Start the water pump by-pass hose on the intake manifold. Be sure the holes in the manifold gaskets and manifold are in alignment. Install the manifold retaining bolts and tighten them to 23-28 foot-pounds torque, working from the center to the ends. Remove the distributor and the engine lifting sling and eye bolts. Install the radiator supply tank.

4. Install the valve push rods in their proper sequence, making sure the lower ends of the rods are positioned in the lifter push rod cup.

5. Crank the engine until the No. 1 piston is on T.D.C. at the end of

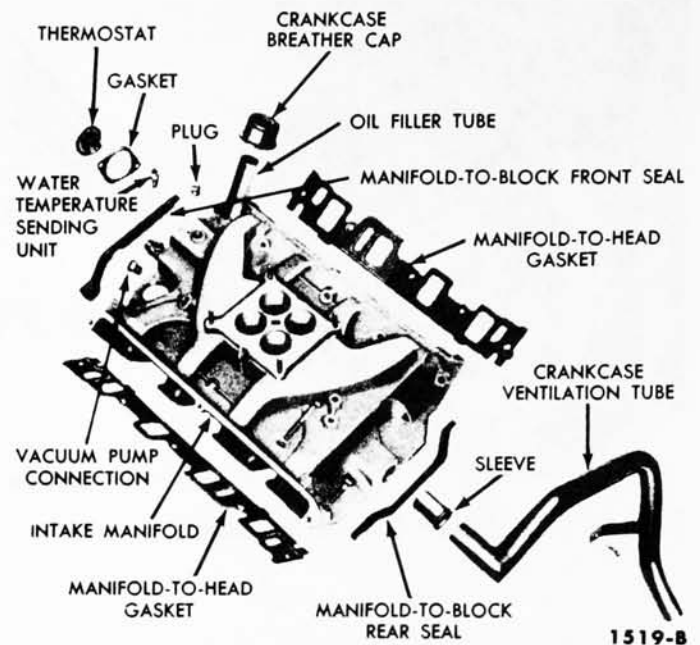

FIG. 48—Intake Manifold Assembly

the compression stroke. Rotate the crankshaft damper an additional 45° (indicated on the damper by the symbol XX). Install the right valve rocker arm shaft assembly and the baffle plate on the cylinder head with the valve push rods in place and the rocker shaft support bolts finger-tight. Be sure the shaft is turned so that the oil holes are to the bottom. Starting at the No. 4 cylinder, tighten the bolts in sequence, two turns at a time, until the supports fully contact the cylinder head. Tighten the bolts in sequence to 45-50 foot-pounds torque. Starting at the No. 5 cylinder, follow the same procedure for the left valve rocker arm shaft support bolts. The additional time consumed in this procedure will permit the hydraulic lifters to leak down. This will minimize the possibility of bending the push rods, valves, or the rocker arms. **Be sure that the hydraulic lifters have leaked down to their normal operating position before cranking the engine. This is necessary in order to avoid possible damage to the valves, push rods, or valve rocker arms.**

6. Install the automatic choke heat tube. Rotate the crankshaft damper until the No. 1 piston is on

17) ins

**100% SATISFACTION GUARANTEED**

**BUY IT NOW!**

**Click Here To Order**

PayPal American Express Discover Novus MasterCard VISA

T.D.C., then position the distributor in the block with the rotor at the No. 1 firing position and the points open. Install the hold down clamp.

Connect the distributor vacuum line. Install the distributor cap. Connect the spark plug wires. Be sure the spark plug wires for No. 7 and 8

cylinders are properly positioned. See Fig. 9 on page 1-48. Install the vacuum booster pump line and the carburetor fuel inlet line.

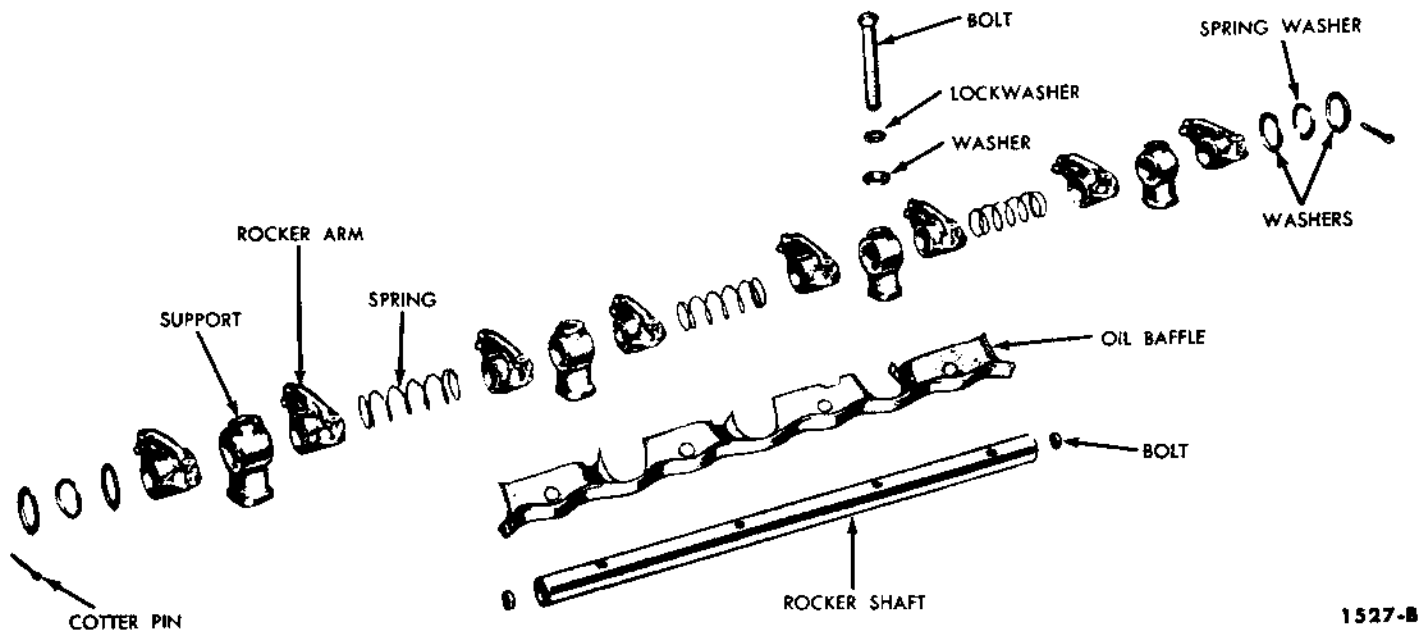

FIG. 50—Valve Rocker Arm Shaft Assembly

## 7 DISASSEMBLY AND ASSEMBLY OF COMPONENT PARTS

### VALVE ROCKER ARM SHAFT ASSEMBLY

#### DISASSEMBLY

1. Remove the cotter pins from each end of the valve rocker arm shaft, then remove the flat washers and spring washers.
2. Slide the rocker arms, springs, and the supports off the shaft. Be sure to identify all parts.
3. If it is necessary to remove the plugs from each end of the shaft, drill or pierce one plug, then insert a steel rod through the plug and knock out the plug on the opposite end. Working from the open end, knock out the remaining plug.

stall a plug, cup side out, in each end of the rocker arm shaft.

3. Install the rocker arms, supports, and springs in the order shown in Fig. 50. Be sure the oil holes in the shaft are facing downward. Complete the assembly by installing the remaining two flat washers with the spring washer between them and install the cotter pin.

### CYLINDER HEADS

#### DISASSEMBLY

1. Clean the carbon out of the cylinder head combustion chambers before removing the valves.
2. Compress the valve springs (Fig. 51), then remove the spring retainer locks, and release the spring.
3. Remove the sleeve, spring retainer, spring assembly stem seal, and valve. Discard the valve stem seals. Identify all valve parts.

#### ASSEMBLY

1. Install each valve (Fig. 52) in the port from which it was removed or to which it was fitted. Install a new stem seal on the valve.
2. Install the valve spring assembly over the valve, then install the spring retainer and sleeve.
3. Compress the spring and install the retainer locks (Fig. 51).
4. Measure the assembled height of the valve spring from the surface of the cylinder head spring pad to the underside of the spring retainer with dividers (Fig. 53). Check the dividers against a scale. If the assembled height is  $1\frac{5}{64}$  inches or greater, install the necessary 0.030-inch thick spacer(s) between the cylinder head spring pad and the valve spring to bring the assembled height to the recommended dimension of  $1\frac{5}{64}$ - $1\frac{5}{64}$  inches. Do not install spacers unless necessary. Use of spac-

100% SATISFACTION GUARANTEED

**BUY IT NOW!**

Click Here To Order

PayPal American Express Discover Novus MasterCard VISA

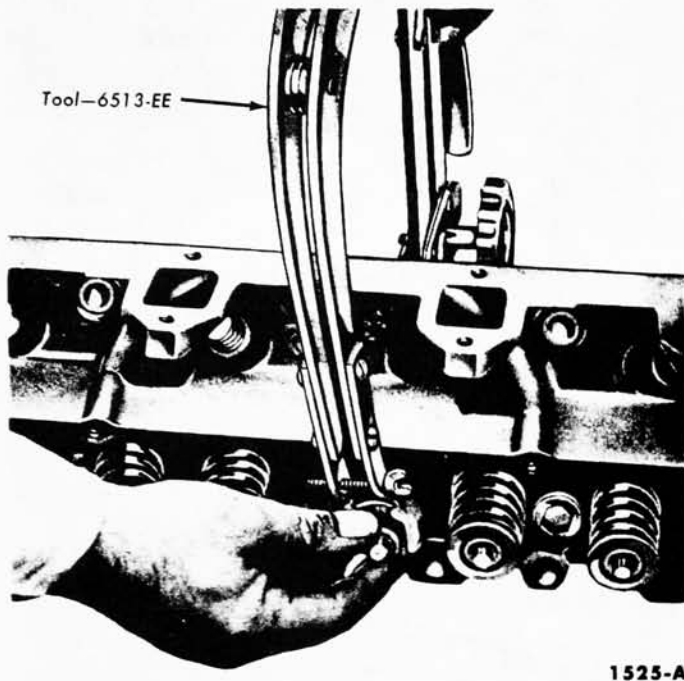

**FIG. 51—Removing or Installing Valve Spring Retainer Locks**

ers in excess of recommendations will result in overstressing the valve springs which will lead to excessive load loss and spring breakage.

#### HYDRAULIC VALVE LIFTERS

Each valve lifter is a matched assembly. If the parts of one lifter are inter-mixed with those of another, improper valve operation may result. Disassemble and assemble each lifter separately. Keep the lifter assemblies in proper sequence so that they can be installed in their original bore.

#### DISASSEMBLY

Remove the lock ring from the lifter assembly with the tool shown in Fig. 18 on page 1-17. Remove the push rod seat plunger and plunger spring. Invert the plunger assembly and remove the disc valve retainer by carefully prying up on it with a screwdriver, then remove the disc valve spring.

valve in position over the oil hole on the bottom of the plunger. Set the disc valve spring on top of the disc. Position the disc valve retainer over the disc and spring and push the retainer down into place on the plunger. Place the plunger spring, then the plunger (open end up) into the lifter body. Place the push rod seat in the plunger. Position the lock ring in the tool shown in Fig. 18 on page 1-17, then install the lock ring in the lifter body. Be sure the lock ring is seated in the groove.

#### PISTON AND CONNECTING ROD

##### DISASSEMBLY

Mark the pistons and pins to assure assembly with the same rod and installation in the same cylinder from which they were removed. Remove the piston rings. Remove the piston pin retainers, then drive the pin out of the piston and connecting rod (Fig. 55). Discard the retainers.

##### ASSEMBLY

The piston, connecting rod and related parts are shown in Fig. 56.

1. Lubricate all parts with light

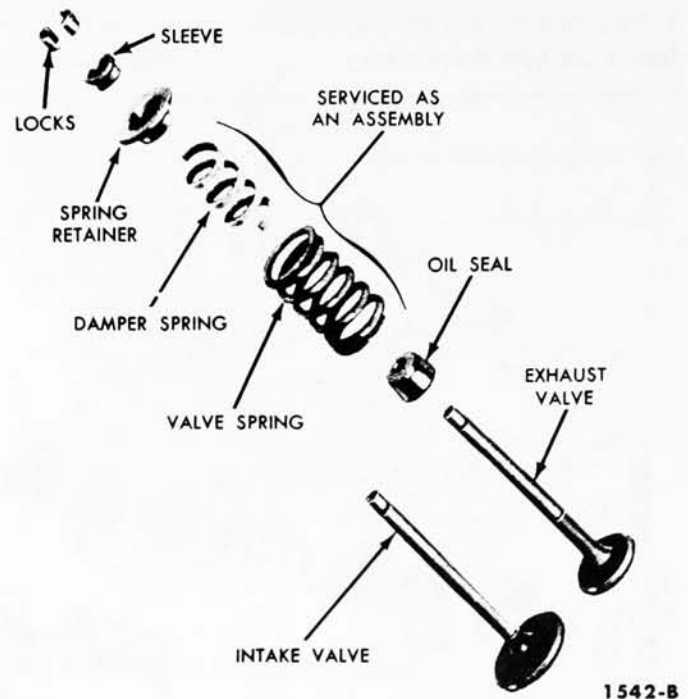

**FIG. 52—Valve Assembly**

engine oil. Position the connecting rod in the piston and push the pin into place. Assemble the piston and connecting rod with the oil squirt hole in the connecting rod positioned as shown in Fig. 57.

2. Insert new piston pin retainers by spiraling them into the piston with the fingers. Do not use pliers. Follow the instructions contained on the piston ring package and install the piston rings.

3. Check the ring side clearance of the compression rings with a feeler gauge inserted between the ring and its lower land (Fig. 58). The gauge should slide freely around the entire ring circumference without binding. Any wear that occurs will form a step at the inner portion of the lower land. **If the lower lands have high steps, the piston should be replaced.**

4. Install the bearing inserts in the connecting rod and cap with the tangs fitting in the slots provided. **Do not get dirt or other foreign matter under the inserts. In time the dirt may distort the bearing and cause bearing failure.**

**100% SATISFACTION GUARANTEED**

**BUY IT NOW!**

**Click Here To Order**

PayPal American Express Discover Novus MasterCard VISA

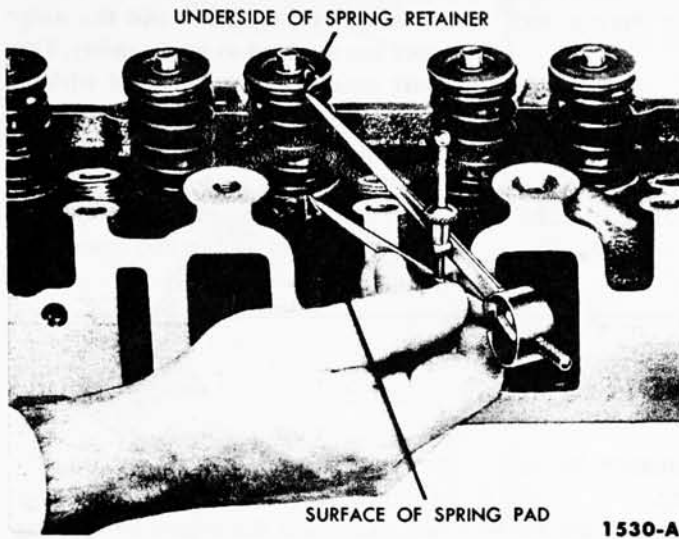

FIG. 53—Valve Spring Assembled Height

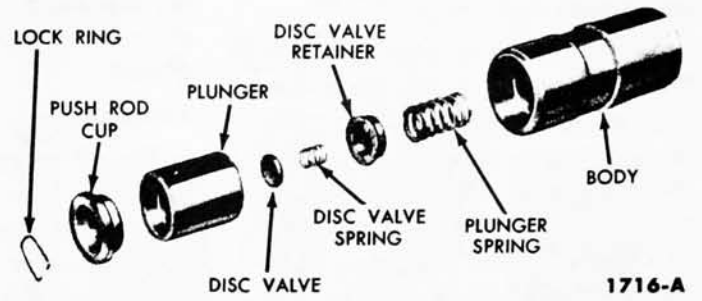

FIG. 54—Hydraulic Valve Lifter Assembly—Typical

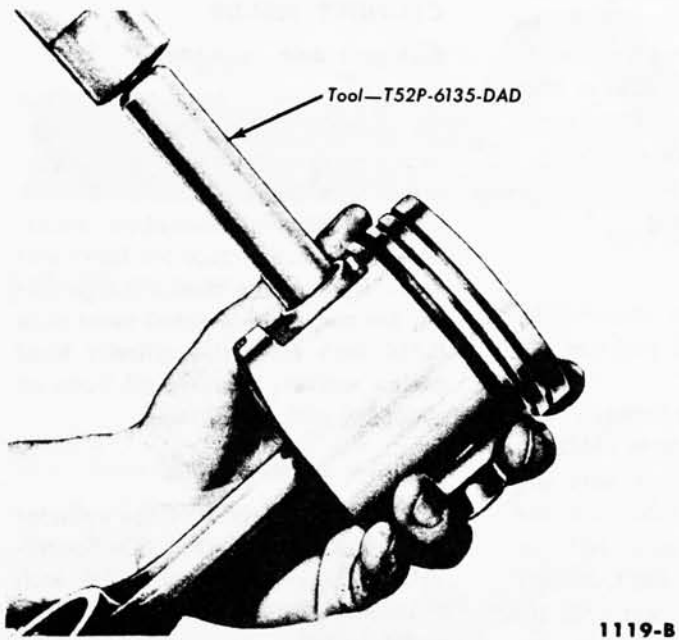

FIG. 55—Piston Pin Removal

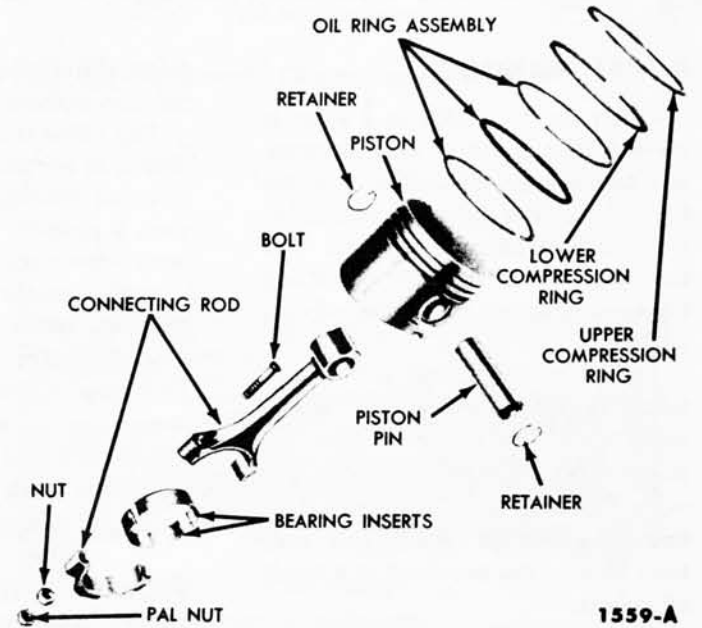

FIG. 56—Piston, Connecting Rod, and Related Parts



FIG. 58—Ring Side Clearance

LEFT BANK      RIGHT BANK

FRONT

TO

1120-A

**100% SATISFACTION GUARANTEED**

**BUY IT NOW!**

**Click Here To Order**

PayPal    American Express    Discover    MasterCard    VISA

Assembly

**OIL PUMP****DISASSEMBLY**

1. Remove the oil inlet tube from the oil pump and remove the gasket.
2. Remove the cover retaining screws, then remove the cover. Remove the inner rotor and shaft assembly, then remove the outer race.
3. Insert a self threading sheet metal screw of the proper diameter

into the oil pressure relief valve chamber cap and pull the cap out of the chamber. Remove the spring and plunger.

**ASSEMBLY**

The oil pump assembly is shown in Fig. 59.

1. Oil all parts thoroughly. Install the oil pressure relief valve plunger, spring, and new cap.

2. Install the outer race, and the inner rotor and shaft assembly. **The inner rotor and shaft, and the outer race are serviced as an assembly. One part should not be replaced without replacing the other.** Install the cover and tighten the cover retaining screws to 6-9 foot-pounds torque. Position a new gasket and the oil inlet tube on the oil pump and install the retaining bolts.

**8 CLEANING, INSPECTION, AND RECONDITIONING****INTAKE MANIFOLD**

Clean the manifolds in a suitable solvent, then dry them with compressed air. Scrape all carbon deposits from the center exhaust passage below the carburetor heat riser. This carbon acts as an insulator restricting the heating action of the hot exhaust gases.

Inspect the manifold for cracks, leaks, or other defects that would make it unfit for further service. Replace all studs that are stripped or otherwise damaged. **Remove all filings and foreign matter that may have entered the manifold as a result of repairs.**

Check the baffle plate on the underside of the manifold for looseness.

**EXHAUST MANIFOLD AND EXHAUST GAS CONTROL VALVE**

Clean out the automatic choke air heat chamber of the right exhaust manifold (Fig. 60). Make sure the air inlet and outlet holes are completely open. Blow out the automatic choke air heat tube with compressed air.

Check the thermostatic spring of the exhaust gas control valve to make sure it is hooked on the stop pin. The spring stop is at the top of the valve housing when the valve is properly installed. The action of the valve is

freely through approximately 90° of rotation without binding.

The valve is closed when the engine is at normal operating temperature and running at idle speed. However, a properly operating valve will open when very light finger pressure is applied to the counterweight. Rapidly accelerate the engine to make sure the valve momentarily opens. The valve is designed to open when the engine is at normal operating temperature and is operated at high rpm. Free stuck valves with a penetrating oil and graphite mixture.

**VALVE ROCKER ARM SHAFT ASSEMBLY**

Clean all the parts thoroughly. Make sure that all oil passages are open.

Check the clearance between each rocker arm and the shaft by checking the I.D. of the rocker arm bore and the O.D. of the shaft. If the clearance between any rocker arm and the shaft exceeds the wear limit, replace the shaft and/or the rocker arm. Inspect the shaft and the rocker arm bore for nicks, scratches, scores, or scuffs. Dress up minor surface defects with a hone.

Inspect the pad at the valve end of the rocker arms for a grooved radius. If the pad is grooved, replace the rocker arm. **Do not attempt to true this surface by grinding.**

**PUSH RODS**

Check the ends of the push rods for nicks, grooves, roughness, or excessive wear.

The push rods can be visually checked for straightness while they are installed in the engine by rotating them with the valve closed. They also can be checked with a dial indicator. (Fig. 61). If the runout exceeds the maximum limit at any point, discard the rod. **Do not attempt to straighten push rods.**

**CYLINDER HEADS****CLEANING AND INSPECTION**

Clean the valve guide bores with a valve guide cleaning tool. Use cleaning solvent to remove old gasket sealer, dirt, and grease.

Check the cylinder head for cracks, and the gasket surface for burrs and nicks. Replace the head if it is cracked. **Do not plane or grind more than 0.010 inch from the cylinder head gasket surface.** Remove all burrs or scratches with an oil stone.

**CYLINDER HEAD FLATNESS**

Check the flatness of the cylinder head gasket surface (Fig. 62). Specifications for flatness are 0.006 inch maximum overall, or 0.003 inch in any 6 inches.

**VALVE SEAT RUNOUT**

Check the valve seat runout with an accurate gauge (Fig. 63). Follow the instructions of the gauge manufacturer. The total runout should not exceed the wear limit.

**VALVE SEAT WIDTH**

Measure the valve seat width (Fig. 64). The intake valve seat width limits are 0.060-0.080 inch and the exhaust valve seat width limits are 0.070-0.090 inch.

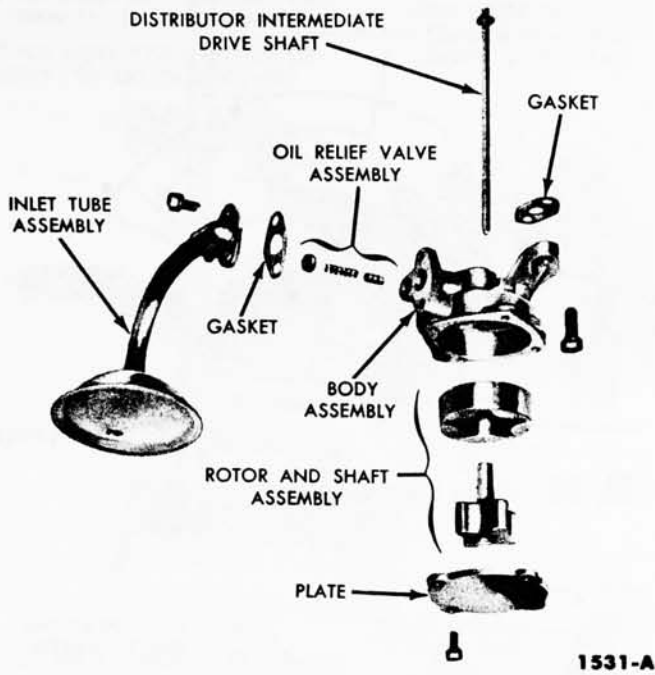

FIG. 59—Oil Pump Assembly

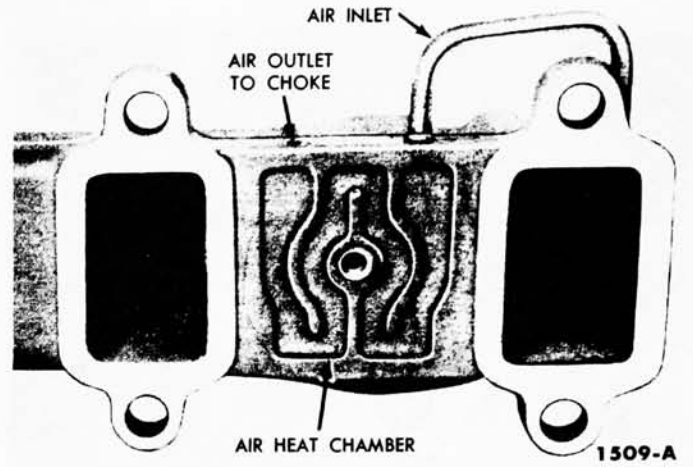

FIG. 60—Automatic Choke Heat Chamber

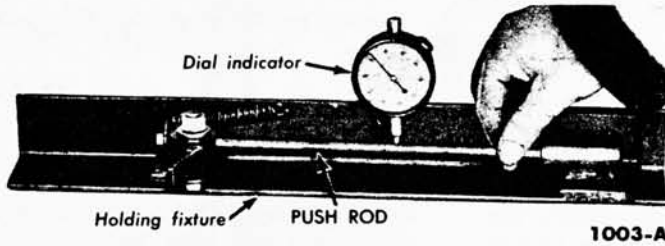

FIG. 61—Push Rod Runout



FIG. 62—Cylinder Head Flatness

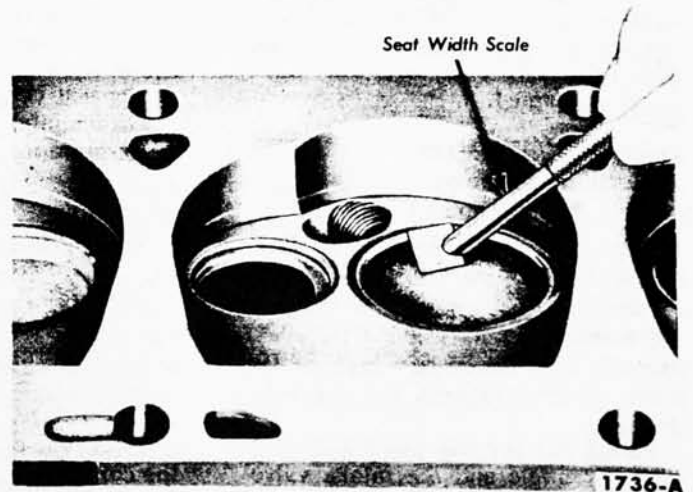

FIG. 64—Valve Seat Width

**100% SATISFACTION GUARANTEED**

**BUY IT NOW!**

**Click Here To Order**

PayPal | American Express | Discover | MasterCard | VISA

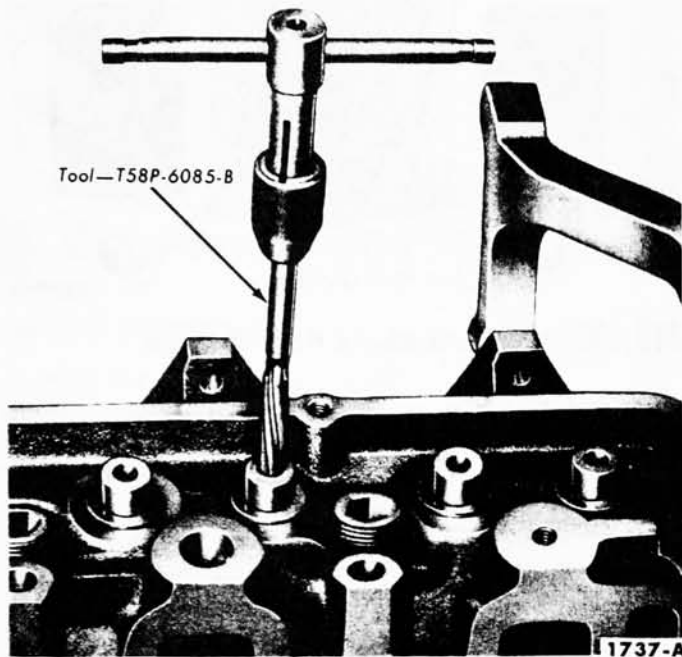

FIG. 65—Reaming Valve Guides

#### REAMING VALVE GUIDES

If it becomes necessary to ream a valve guide (Fig. 65) to install a valve with an oversize stem, a reaming kit is available which contains the following reamer and pilot combinations; a 0.003-inch O.S. reamer with a standard diameter pilot, a 0.015-inch O.S. reamer with a 0.003-inch O.S. pilot, and a 0.030-inch reamer with a 0.015-inch O.S. pilot.

When going from a standard size valve to an oversize valve, always use the reamers in sequence. **Always reface the valve seat after the valve guide is reamed.**

#### REFACING VALVE SEATS

Refacing of the valve seats should be closely coordinated with the refacing of the valve face so the finished seat will match the valve face and be centered. This is important so that the seat will have a good com-

up pits, grooves, or to correct the valve seat runout. After the seat is ground, measure the seat width (Fig. 64). Narrow the seat, if necessary to bring it within limits.

If the valve seat width exceeds the maximum limits, remove enough stock from the top edge and/or bottom edge of the seat to reduce the width to specifications (Fig. 66).

On the exhaust valve seat, use a 30° angle grinding wheel to remove stock from the bottom of the seat (raise the seat) and use a 60° angle wheel to remove stock from the top of the seat (lower the seat).

On the intake valve seat, use a 15° angle grinding wheel to remove stock from the top of the seat (lower the seat).

The finished valve seat should contact the approximate center of the valve face. To determine where the valve seat contacts the face, coat the seat with Prussian blue, then set the valve in place. Rotate the valve with light pressure. If the blue is transferred to the center of the valve face, the contact is satisfactory. If the blue is transferred to the top edge of the valve face, lower the valve seat. If the

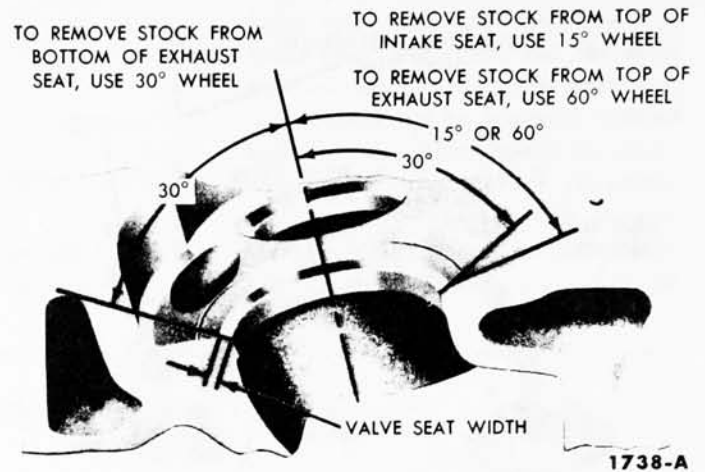

FIG. 66—Valve Seat Refacing

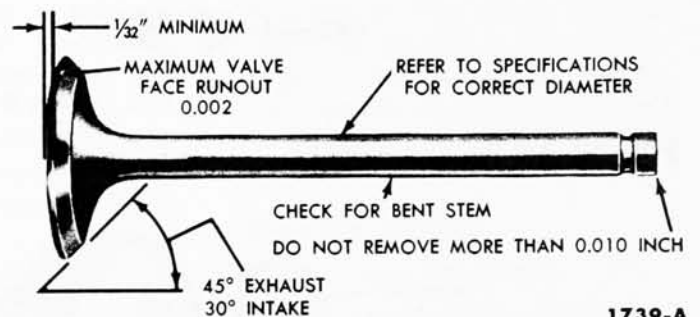

FIG. 67—Critical Valve Tolerances

blue is transferred to the bottom edge of the valve face, raise the valve seat.

After refacing the valve seat, it is good practice to lightly lap in the valve with a medium grade lapping compound. Remove all the compound from the valve and seat after the lapping operation.

#### VALVES

##### CLEANING AND INSPECTION

Remove all carbon and varnish from the valve with a fine wire brush or buffing wheel. The critical inspection points and tolerances of the valve are illustrated in Fig. 67.

Inspect the valve face and the edge of the valve head for pits, grooves, scores, or other defects. Inspect the stem for a bent condition and the end of the stem for grooves or scores. Check the valve head for signs of burning or erosion, warpage, and cracking. Defects, such as minor pits, grooves, etc. may be removed. Discard valves that are severely damaged.

Inspect the valve springs and valve damper springs, valve spring retainers, locks, and sleeves for defects. Discard any defective parts.

**100% SATISFACTION GUARANTEED**

**BUY IT NOW!**

**Click Here To Order**

PayPal, American Express, Discover, MasterCard, VISA

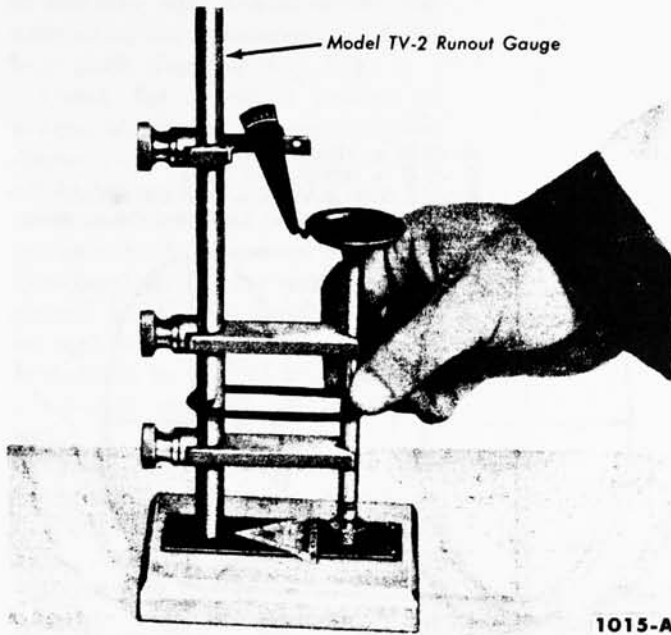

1015-A

FIG. 68—Valve Face Runout

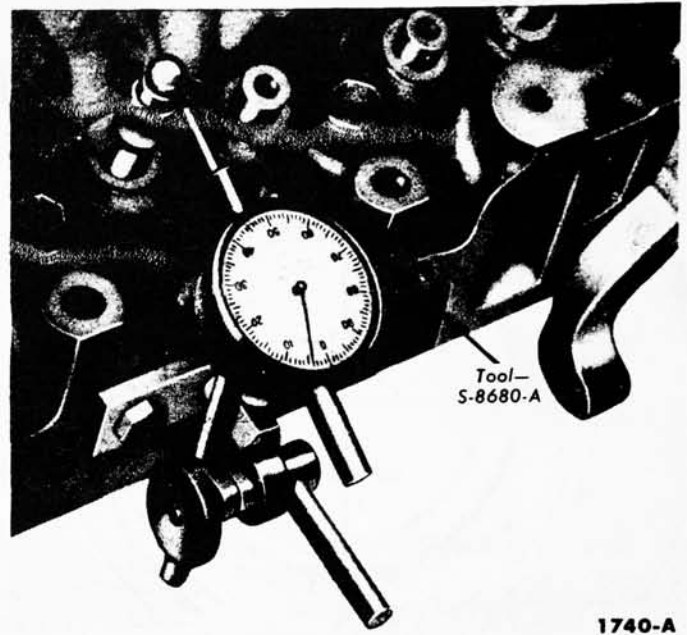

1740-A

FIG. 69—Valve Stem Clearance

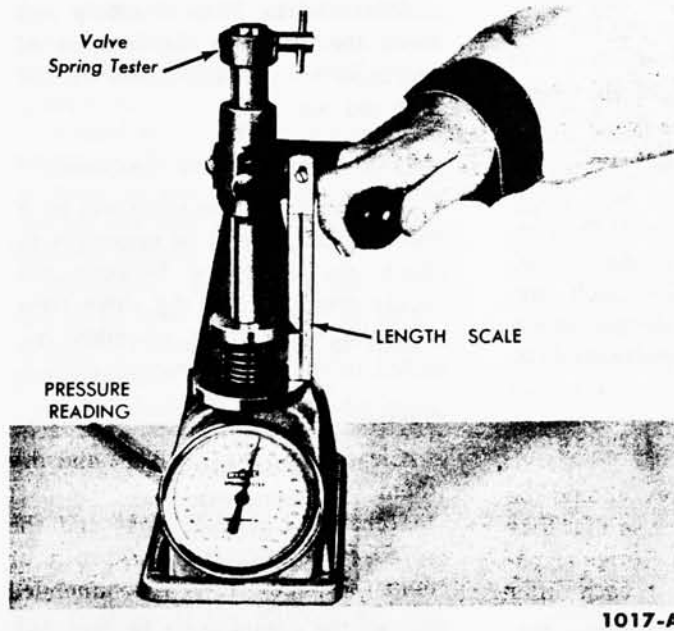

1017-A

FIG. 70—Valve Spring Pressure

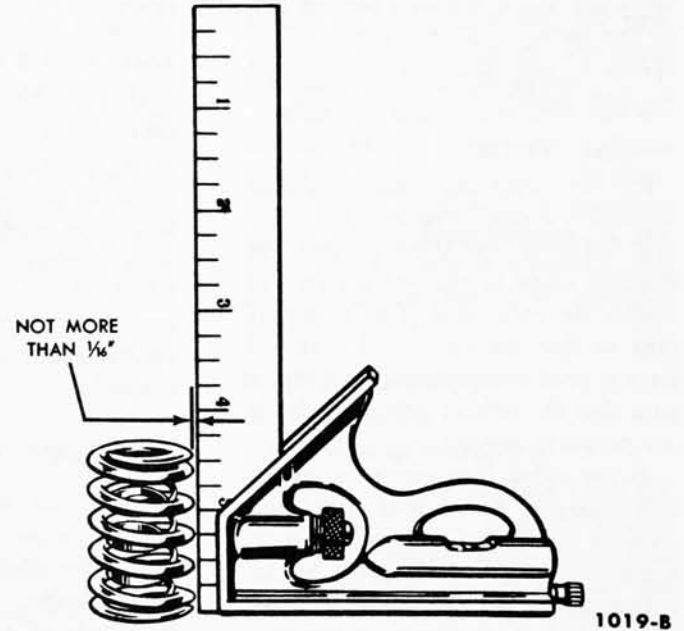

1019-B

FIG. 71—Valve Spring Squareness

**VALVE FACE RUNOUT**

Check the valve face runout (Fig. 68). The wear limit is 0.002 inch total indicator reading.

**VALVE STEM CLEARANCE**

Check the valve stem to valve clearance of each valve in its

tacts the upper surface of the valve guide. Position a dial indicator with a flat tip against the center portion of the spherical section of the tool at approximately 90° to the valve stem. Move the tool back and forth on a plane that parallels normal rocker arm action and take the indicator reading without lifting the tool from the valve guide upper surface. Divide the indicator reading by 2 (division factor of the tool) to obtain the actual stem clearance. If the clearance exceeds the wear limit, try a new valve.

**VALVE SPRING PRESSURE**

Check the valve spring assembly for proper pressure (Fig. 70). Weak valve springs cause poor engine performance; therefore, if the pressure of any spring approaches the wear limit, replace the spring.

**VALVE SPRING SQUARENESS**

Check each spring for squareness using a steel square and a surface plate (Fig. 71). Stand the spring and square on end on the surface plate. Slide the spring up to the square.

**100% SATISFACTION GUARANTEED**

**BUY IT NOW!**

**Click Here To Order**

PayPal, American Express, Discover, MasterCard, VISA

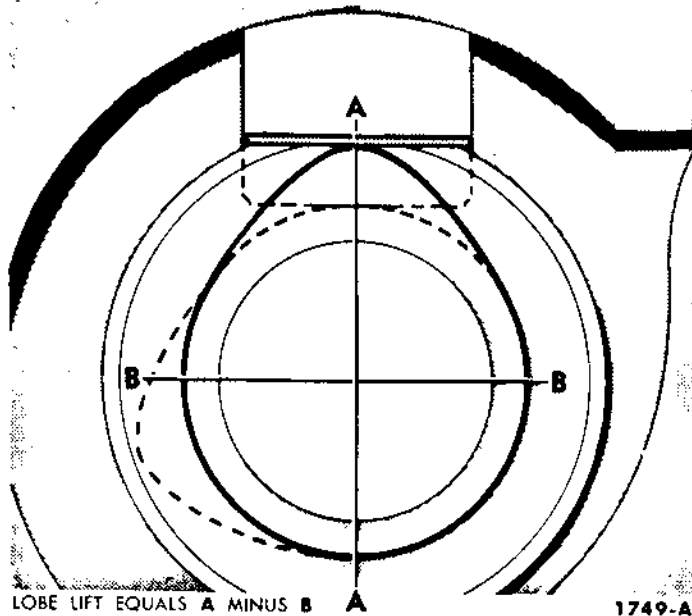

FIG. 72—Camshaft Lobe Lift Measurement

Revolve the spring slowly and observe the space between the top coil of the spring and the square. If the spring is out of square more than  $\frac{1}{16}$  inch, replace it.

#### REFACING VALVES

The valve refacing operation should be closely coordinated with the valve seat refacing operation so that the finished angle of the valve face will match the valve seat. This is important so that the valve and seat will have a good compression tight fit. Be sure that the refacer grinding wheels are properly dressed.

If the valve face runout is excessive and/or to remove pits and grooves, reface the exhaust valves to a true  $45^\circ$  angle. Reface the intake valves to a true  $30^\circ$  angle. Remove only enough stock to correct the runout or to clean up the pits and grooves. If the edge of the valve head is less than  $\frac{1}{32}$  inch after grinding, replace the valve as the valve will run too hot in the engine.

Grind off all grooves or score marks from the end of the valve stem, then transfer as necessary. Do not remove more than 0.010 inch from

valve and seat after the lapping operation.

#### SELECT FITTING VALVES

If the valve stem to valve guide clearance exceeds the wear limit, it is recommended that the valve guide be reamed for the next oversize valve stem (page 1-32). Valves with oversize stem diameters of 0.003, 0.015, and 0.030 inch are available for service. **Always reface the valve seat when the valve guide is reamed.**

#### HYDRAULIC VALVE LIFTERS

The lifter assemblies should be kept in proper sequence so that they can be installed in their original position. Inspect and test each lifter separately so as not to intermix the internal parts. **If any part of the lifter assembly needs replacing, replace the entire lifter assembly.**

#### CLEANING AND INSPECTION

Thoroughly clean all the parts in clean solvent and wipe them with a clean, lint free cloth.

Inspect the parts and discard the entire lifter assembly if any part shows signs of pitting, scoring, galling, or evidence of non-rotation. Also, replace the entire assembly if the plunger is not free in the body. The plunger should drop to the bot-

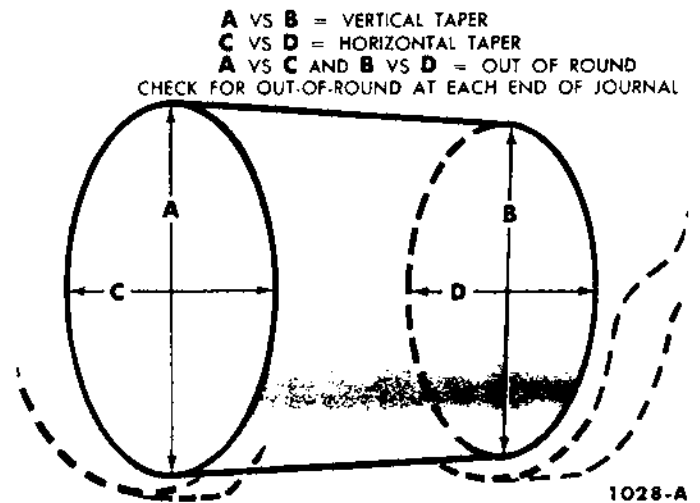

FIG. 73—Crankshaft Journal Measurements

tom of the body by its own weight.

Assemble the lifter assembly and check the assembly for freeness of operation by pressing down on the push rod cup.

#### ROCKER ARM TO VALVE CLEARANCE

If the valve and/or valve seat have been refaced, it will be necessary to check the clearance between the rocker arm pad and the valve stem with the valve train assembly installed in the engine (page 1-12).

#### TIMING CHAIN

Clean all parts in solvent and dry them with compressed air. Inspect the chain for broken links and the sprockets for cracks, and worn or damaged teeth. It is recommended that all the components be replaced if any one item needs replacement.

#### CAMSHAFT AND BEARINGS

Clean the camshaft in solvent and wipe dry. Inspect the camshaft lobes for pitting, scoring, and signs of abnormal wear. Lobe wear characteristics may result in pitting in the general area of the nose portion of the lobe. This pitting is not detrimental to the operation of the camshaft, therefore, the cam should not be replaced until the camshaft lobe lift loss has exceeded 0.005 inch. The lift of suspected worn lobes should be

**100% SATISFACTION GUARANTEED**

**BUY IT NOW!**

**Click Here To Order**

PayPal American Express Discover Novus MasterCard VISA

checked by measuring over the top of the lobe with a micrometer and subtracting the measurement of the base circle diameter (Fig. 72).

Check the camshaft journal to bearing clearances by measuring the diameter of the journals and the I.D. of the bearings. If the clearance exceeds the wear limit, the camshaft journals should be ground for undersize bearings or the camshaft replaced, and/or the bearings should be replaced. Bearings are available prefinished to size for standard and 0.015-inch undersize journal diameters.

Check the distributor drive gear for broken or chipped teeth.

Remove light scuffs, scores, or nicks from the camshaft machined surfaces with a smooth oilstone.

## CRANKSHAFT

### CLEANING AND INSPECTION

Handle the crankshaft with care to avoid possible fractures or damage to the finished surfaces. Clean the crankshaft with solvent, then blow out all oil passages with compressed air.

Inspect main and connecting rod journals for cracks, scratches, grooves, or scores. Dress minor imperfections with an oilstone. Regrind severely marred journals.

Measure the diameter of each journal in at least four places to determine out-of-round, taper, or undersize condition (Fig. 73).

If the journals exceed the wear limit, they should be reground to size for the next undersize bearing.

### REFINISHING JOURNALS

Regrind the journal to give the proper clearance with the next undersize bearing. If the journal will not "clean up" to give the proper clearance with the maximum undersize bearing available, replace the crankshaft.

Always reproduce the same journal shoulder radius that existed originally. Too small a radius will result in fatigue failure of the crankshaft. Too large a radius will result in bearing failure due to radius ride of the

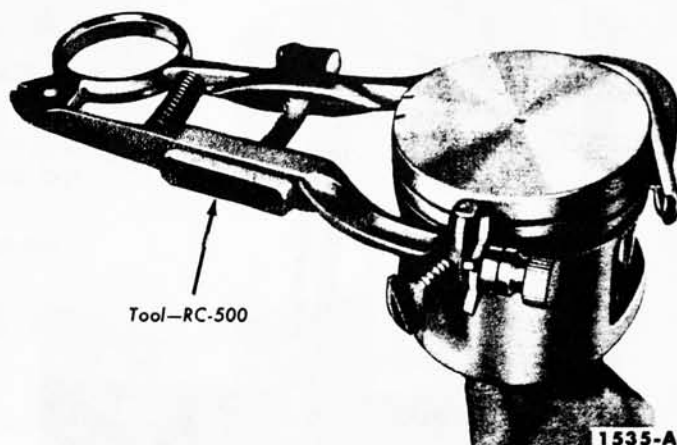

FIG. 74—Cleaning Ring Grooves

## CONNECTING RODS

The connecting rods and related parts should be carefully inspected and checked for conformance to specifications. Various forms of engine wear caused by these parts can be readily identified.

A shiny surface on the pin boss side of the piston usually indicates that a connecting rod is bent or the piston pin hole is not in proper relation to the piston skirt and ring grooves.

Abnormal connecting rod bearing wear can be caused by either a bent connecting rod, an improperly machined crankpin, or a tapered connecting rod bore.

Twisted connecting rods will not create an easily identifiable wear pattern, but badly twisted rods will disturb the action of the entire piston, rings, and connecting rod assembly and may be the cause of excessive oil consumption.

### CLEANING AND INSPECTION

Clean the connecting rod in solvent, including the connecting rod bore and the back of the inserts. **Do not use a caustic cleaning solution.** Blow out all passages with compressed air.

Inspect the connecting rods for signs of fractures and the bearing bores for out-of-round and taper. If the bore exceeds the recommended limits and/or if the rod is fractured, it should be replaced.

Check the piston pin to connecting rod bushing clearance. Replace the connecting rod if the bushing is so worn that it cannot be reamed or honed for an oversize pin.

Replace defective connecting rod nuts and bolts.

Inspect each bearing carefully. Replace bearings that have a scored, chipped, or worn surface. For the different types of bearing failures and their causes refer to Fig. 77. Check the clearance of bearings that appear to be satisfactory. Fit new bearings where necessary, following the recommended procedure.

After the connecting rods are assembled to the piston, check them for bend or twist on a suitable alignment fixture. Follow the instructions of the fixture manufacturer. If the bend and/or twist is excessive, the connecting rod should be straightened or replaced.

## PISTONS, PINS, AND RINGS

### CLEANING AND INSPECTION

Remove carbon deposits from the piston surfaces and from the underside of the piston head. Clean gum or varnish from the piston skirt, piston pins, and rings with solvent. **Do not use a caustic cleaning solution or a wire brush to clean pistons.** Clean the ring grooves with a ring groove cleaner (Fig. 74). Make sure the oil ring slots (or holes) are clean.

Carefully inspect the pistons for fractures at the ring lands, skirt, and pin bosses, and for scuffed, rough, or scored skirts. If the lower inner portion of the ring grooves have high steps, replace the piston. The step will interfere with ring operation and cause excessive ring side clearance.

Spongy, eroded areas near the edge of the top of the piston are usually caused by detonation, or pre-ignition.

**100% SATISFACTION GUARANTEED**

**BUY IT NOW!**

**Click Here To Order**

PayPal   American Express   Discover   MasterCard   VISA

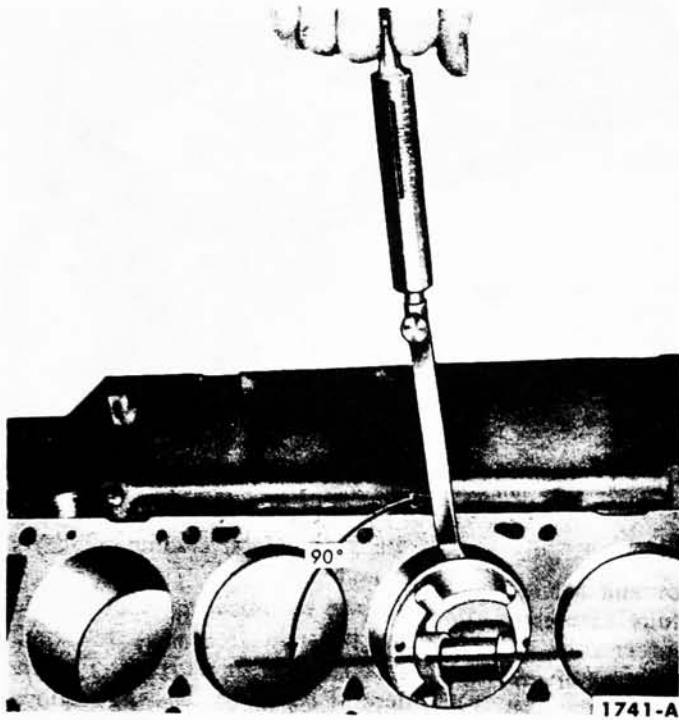

FIG. 75—Checking Piston Fit

A shiny surface on the thrust surface of the piston, offset from the centerline between the piston pin holes, can be caused by a bent connecting rod. Replace pistons that show signs of excessive wear, wavy ring lands, fractures, and/or damage from detonation or pre-ignition.

Check the piston to cylinder bore clearance with a tension scale and ribbon and the ring side clearance following the recommended procedures.

Replace piston pins showing signs of fracture or etching and/or wear. Check the piston pin fit in the piston and rod bushing.

Replace all rings that are scored, chipped, or cracked. Check the end gap and side clearance. It is good practice to always install new rings when overhauling the engine. **Rings should not be transferred from one piston to another regardless of mileage.**

#### FITTING PISTONS

Pistons are available for service in standard sizes and oversizes for use in cylinders that have been rebored.

**100% SATISFACTION GUARANTEED**

**BUY IT NOW!**

**Click Here To Order**

PayPal | American Express | Discover | MasterCard | VISA



FIG. 76—Piston Ring Gap

**low the cylinder bore to cool before the piston fit is checked.**

Calculate the size piston to be used by taking a cylinder bore check (Fig. 81), then select the proper size piston to provide the desired clearance.

Make sure the piston and cylinder bore are clean and dry. Attach a tension scale to the end of a feeler gauge ribbon that is free of dents or burrs. The feeler ribbon should be 1/2-inch wide and of the recommended thickness for the existing condition.

Position the ribbon in the cylinder bore so that it extends the entire length of the piston at 90° from the piston pin location. Invert the piston and install it in the bore so that the end of the piston is about 1 1/2 inches below the top of the cylinder block and the piston pin is parallel to the crankshaft axis.

Hold the piston and slowly pull the scale in a straight line with the ribbon, noting the pull required to remove the feeler ribbon (Fig. 75).

If the pull is within limits for the existing condition, the piston fit is satisfactory.

If the scale reading is greater than the maximum allowable pull, recheck calculations to be sure that the proper size piston has been selected, check for a damaged piston, then try a new piston.

If the scale reading is less than the minimum allowable pull, recheck calculations before trying another piston. If none can be fitted, refinish the cylinder for the next size piston.

**When a piston has been fitted, mark it for assembly in the cylinder to which it was fitted.**

If the taper and out-of-round conditions of the cylinder bore are within limits, new piston rings will give satisfactory service provided the piston clearance in the cylinder bore is within limits. If the new rings are to be installed in a used cylinder that has not been refinished, remove the cylinder wall "glaze."

Select the proper ring set for the size piston to be used. The rings must be checked for proper gap in the cylinder bore and for the proper side clearance in the piston grooves. First, check each ring for proper gap as follows:

Position the ring in the cylinder bore in which it is going to be used. Push the ring down into the cylinder bore area where normal ring wear is not encountered. Use the head of a piston to position the ring so that the ring is square with the cylinder wall. **Use caution to avoid damage to the ring or cylinder bore.** Measure the gap between the ends of the ring with a feeler gauge (Fig. 76).

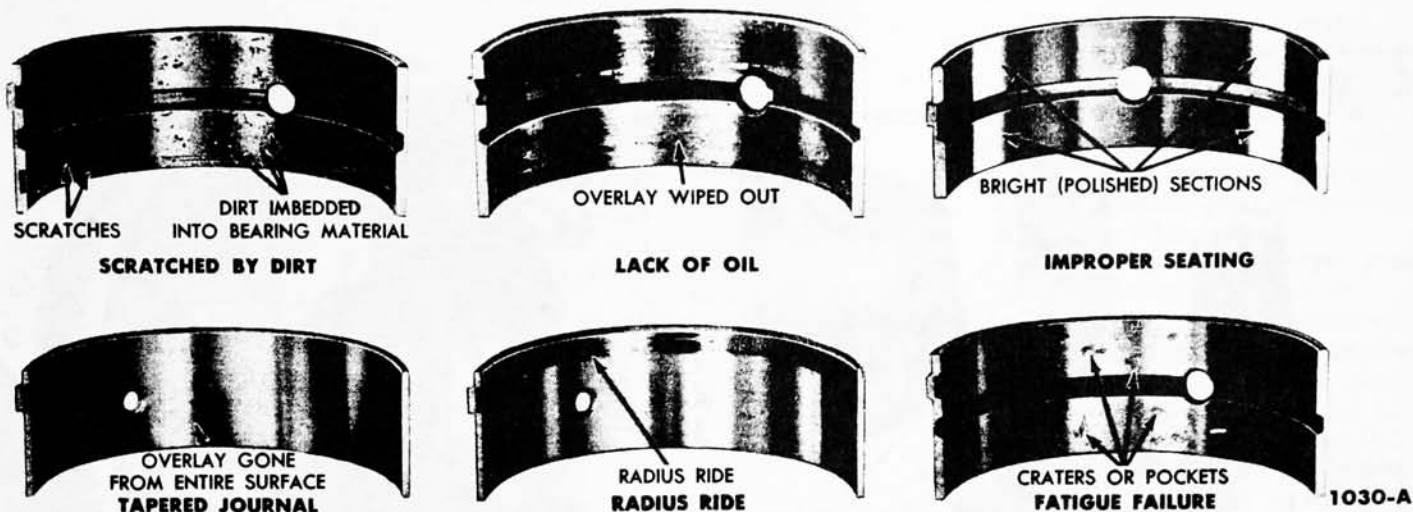

FIG. 77—Bearing Failures

If the gap is less than the recommended lower limit, try another ring set.

**FITTING PISTON PINS**

The piston pin fit should be a light thumb press fit at normal temperature (70° F). Standard piston pins are color coded green. Pins of 0.001-inch oversize (color coded blue) and 0.002-inch oversize (color coded yellow) are available.

If the pin hole in the piston must be reamed, use an expansion-type, piloted reamer. Place the reamer in a vise and revolve the piston around the reamer. Set the reamer to the size of the pin bore, then expand the reamer slightly and trial ream the pin bore. Take a light cut. Use a pilot sleeve of the nearest size to maintain alignment of the bores.

Check the hole size, using the new piston pin. If the bore is small, expand the reamer slightly and make another cut. Repeat the procedure until the proper fit is obtained. Check the piston pin for fit in the respective rod bushing. If necessary, ream or hone the bushing to fit the pin.

Install the piston pin in the piston and rod. Install a new retainer at each end of the pin to hold it in place. Spiral the retainers into position with the fingers. Do not use pliers. Make sure the retainers are properly seated in their groove.

chipped, or worn surface should be replaced. Typical examples of bearing failures and their causes are shown in Fig. 77. Check the clearance of bearings that appear to be satisfactory with Plastigage. Fit new bearings following the recommended procedure.

**BEARING REPLACEMENT**

The main bearing inserts are selective fit and do not require reaming to size upon installation. **Do not file or lap bearing caps or use shims to obtain the proper bearing clearance.**

Selective fit bearings are available for service in standard sizes only. Standard bearings are divided into two sizes and are identified by a daub of red or blue paint. **Red marked bearings increase the clearance; blue marked bearings decrease the clearance.** Undersize bearings, which are not selective fit, are available for use on journals that have been reground.

Normally, bearing journals wear evenly and are not out-of-round. However, if a bearing is being fitted to an out-of-round journal, be sure to fit the bearing to the maximum

diameter of the journal. If the bearing is fitted to the minimum diameter with minimum clearance, interference may result, causing an early failure. It is not recommended that bearings be fitted to a crankshaft journal which exceeds the maximum out-of-round specifications. **When replacing standard bearings with new bearings, it is good practice to first try to obtain the proper clearance with two blue bearing halves.**

Do not get dirt or other foreign matter under the inserts. In time the dirt may distort the bearing and cause bearing failure.

**Main Bearings.** The following procedure is for the engine installed in the chassis with the crankshaft not removed. If the engine is on a work stand, follow steps 2-5. In step 4, it is not necessary to support the crankshaft because the engine will be inverted. Place the Plastigage on the crankshaft journal (Fig. 78) instead of on the bearing surface if the engine is on a work stand.

**1. Replace one bearing at a time, leaving the other bearings securely fastened. Remove the main bearing**

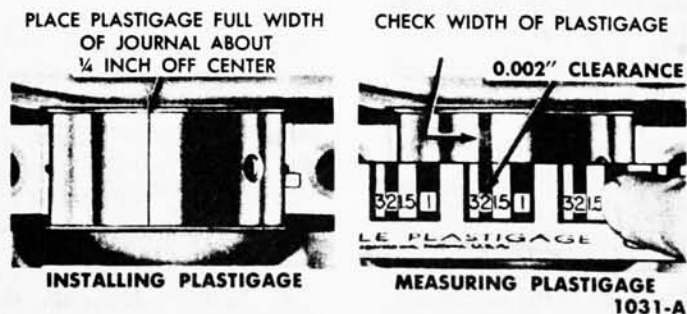

FIG. 78—Installing and Measuring Plastigage—Engine On Work Stand

**100% SATISFACTION GUARANTEED**

**BUY IT NOW!**

**Click Here To Order**

PayPal, American Express, Discover, MasterCard, VISA

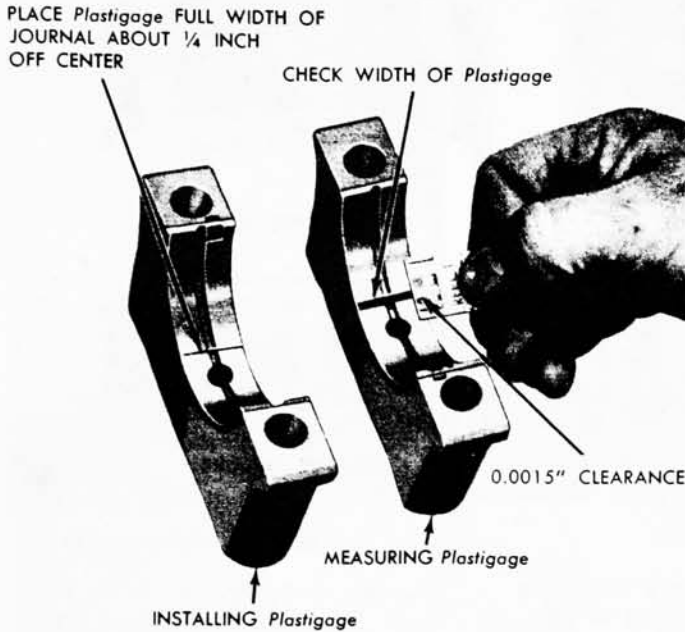

1558-B

**FIG. 79—Installing and Measuring Plastigage—Engine in Chassis**

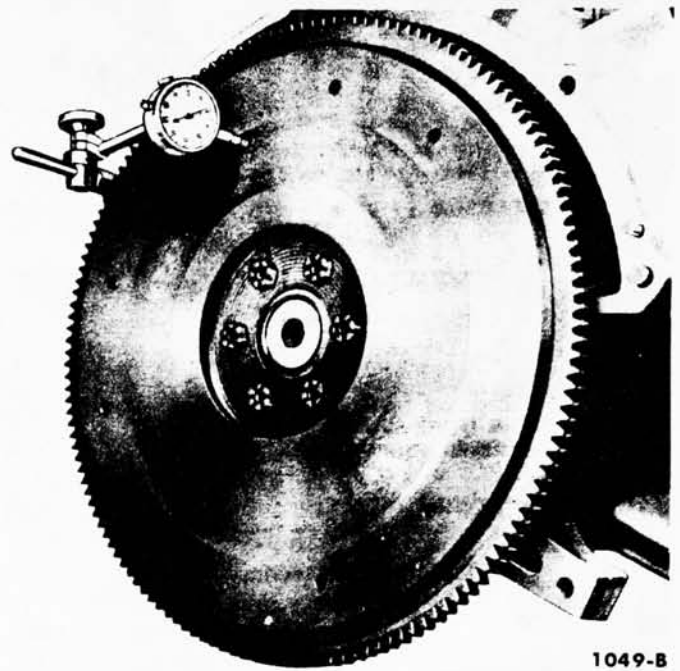

1049-B

**FIG. 80—Flywheel Face Runout**

cap to which new bearings are to be installed. Insert the upper bearing removal tool (Tool 6331) in the oil hole in the crankshaft. Rotate the crankshaft in the direction of engine rotation to force the bearing out of the block.

2. To install the upper main bearing, place the plain end of the bearing over the shaft on the locking tang side of the block. Using Tool 6331, rotate the crankshaft in the opposite direction of engine rotation until the bearing seats itself. Remove the tool. Replace the cap bearing. Clean the crankshaft journal and bearings.

3. Support the crankshaft so its weight will not compress the Plastigage and provide an erroneous reading. Position a small jack so it will bear against the counterweight adjoining the bearing which is being checked. Place a piece of Plastigage on the bearing surface the full width of the bearing cap and about 1/4 inch off center (Fig. 79). Install the cap and tighten the bolts to 95-105 foot-pounds torque. **Do not turn the crankshaft while the Plastigage is in place.** Remove the cap, then using the

If the clearance is less than the specified limits, try two red bearing halves or a combination of red and blue depending upon the condition. If the standard bearings do not bring the clearance within the desired limits, grind the crankshaft journal, then install undersize bearings.

4. After the bearing has been checked and found to be satisfactory, apply a light coat of engine oil to the journal and bearings, then install the bearing cap. Tighten the cap bolts to 95-105 foot-pounds torque.

5. If the rear main bearing is replaced, replace the lower oil seal (in the cap) and the side seals. The upper oil seal (in the block) can not be replaced with the crankshaft installed.

#### Connecting Rod Bearings.

1. Install the new bearings in the connecting rod and cap. Pull the connecting rod assembly down firmly on the crankshaft journal. Place a piece of Plastigage on the lower bearing surface, the full width of the cap and about 1/4 inch off center. Install the cap and tighten the connecting rod nuts to 45-50 foot-pounds torque. **Do not turn the crankshaft while the Plastigage is in place.**

2. Remove the cap, then using the Plastigage scale check the width of the Plastigage at the widest point in order to get the minimum clear-

ance. Check the Plastigage at the narrowest point in order to get the maximum clearance. The difference between the two readings is the taper.

If the clearance is less than the specified limits, try two red bearing halves or a combination of red and blue depending upon the condition. If the standard bearings do not bring the clearance within the desired limits, grind the crankshaft journal, then install undersize bearings.

After the bearing clearance has been checked and found to be satisfactory, apply a light coat of engine oil to the journal and bearings, then install the connecting rod cap. Tighten the nuts to 45-50 foot-pounds torque, then install the pal nuts, and tighten them to 3-4 foot-pounds torque.

3. Repeat the procedure for the remaining connecting rods that require new bearings.

#### CONVENTIONAL FLYWHEEL

##### INSPECTION

Inspect the flywheel for cracks, heat check, or other defects that would make it unfit for further service. Machine the friction surface of the flywheel if it is scored or worn. If it is necessary to remove more than 0.045 inch of stock from the original thickness, replace the flywheel.

Inspect the ring gear for worn,

**100% SATISFACTION GUARANTEED**

**BUY IT NOW!**

**Click Here To Order**

PayPal | American Express | Discover | MasterCard | VISA

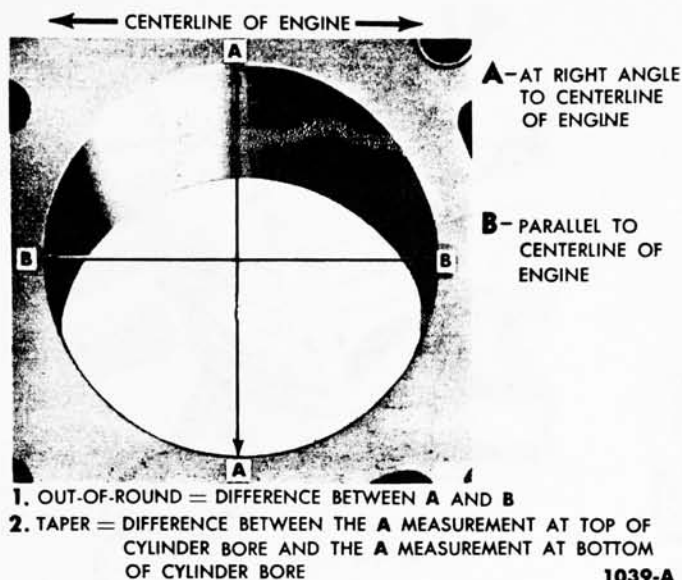

**FIG. 81—Cylinder Bore Out-of-Round And Taper**

chipped, or cracked teeth. If the teeth are damaged, replace the ring gear.

With the flywheel installed on the crankshaft, check the flywheel face runout.

#### FLYWHEEL FACE RUNOUT

Install a dial indicator so that the indicator point bears against the flywheel face (Fig. 80). Turn the flywheel making sure that it is full forward or rearward so that crankshaft end play will not be indicated as flywheel runout.

If the runout exceeds the maximum limit, remove the flywheel and check for burrs between the flywheel and the face of the crankshaft mounting flange. If no burrs exist, check the runout of the crankshaft mounting flange. Replace the flywheel or machine the crankshaft flywheel face if the mounting flange runout is excessive.

#### RING GEAR REPLACEMENT

Heat the defective ring gear with a blow torch on the engine side of the gear, then knock it off the flywheel. **Do not hit the flywheel when removing the ring gear.**

Heat the new ring gear evenly until the gear expands enough to slip off the flywheel. Make sure the

#### CONVERTER DRIVE PLATE

The procedure for checking the converter drive plate for cars with Cruise-O-Matic is covered in Group 3.

#### CYLINDER BLOCK

During the disassembly of the cylinder block for engine overhaul, closely inspect the wear pattern on all parts to help diagnose the cause of wear.

#### CLEANING AND INSPECTION

Thoroughly clean the block in solvent. Remove old gasket material from all machined surfaces. Remove all pipe plugs which seal oil passages, then clean out all the passages. Blow out all passages, bolt holes, etc. with compressed air. Make sure the threads in the cylinder head bolt holes are clean. Dirt in the threads may cause binding and result in a false torque reading. Use a tap to true-up threads and to remove any deposits.

After the block has been thoroughly cleaned, make a check for cracks. Minute cracks not visible to the naked eye may be detected by coating the suspected area with a mixture of 25% kerosene and 75% light motor oil. Wipe the part dry and immediately apply a coating of zinc oxide dissolved in wood alcohol. If cracks are present, the coating will become discolored at the defective area. Replace the block if it is cracked.

Check all machined gasket surfaces for burrs, nicks, scratches, and scores. Remove minor imperfections with an oil stone. Check the flatness of the cylinder block gasket surface following the procedure and specifications recommended for the cylinder head (page 1-30).

Replace all expansion-type plugs that show evidence of leakage.

Inspect the cylinder walls for scoring, roughness, or other signs of wear. Check the cylinder bore for out-of-round and taper. Measure the bore with an accurate gauge following the instructions of the manufacturer. Measure the diameter of each cylinder bore at the top, middle, and bottom with the gauge placed at right angles and parallel to the centerlines of the engine (Fig. 81).

Rebore cylinders that are deeply scored and/or when out-of-round and/or taper exceed the wear limits.

If the cylinder walls have minor surface imperfections, but the out-of-round and taper are within limits, it may be possible to remove the imperfections by honing the cylinder wall and installing new service piston rings providing the piston clearance is within limits. Use the finest grade of honing stone for this operation.

#### REFINISHING CYLINDER WALLS

Honing is recommended for refinishing cylinder walls only when the walls have minor imperfections, such as light scuffs, scratches, etc. The grade of hone to be used is determined by the amount of metal to be removed. Follow the instructions of the hone manufacturer. If coarse stones are used to start the honing operation, leave enough material so that all hone marks can be removed with the finishing hone which is used to obtain the proper piston clearance.

Cylinder walls that are severely marred and/or worn beyond the specified limits should be rebored. Before any cylinder is rebored, all main bearing caps must be in place and tightened to the proper torque so that the crankshaft bearing bores will not become distorted from the boring operation.

Rebore only the cylinder or cylinders that require it. **All pistons are the same weight, both standard and oversize; therefore, various sized pistons can be intermixed without upsetting engine balance.**

Rebore the cylinder with the most wear first to determine the maximum oversize. If the cylinder will not clean

**100% SATISFACTION GUARANTEED**

**BUY IT NOW!**

**Click Here To Order**

PayPal | American Express | Discover | MasterCard | VISA

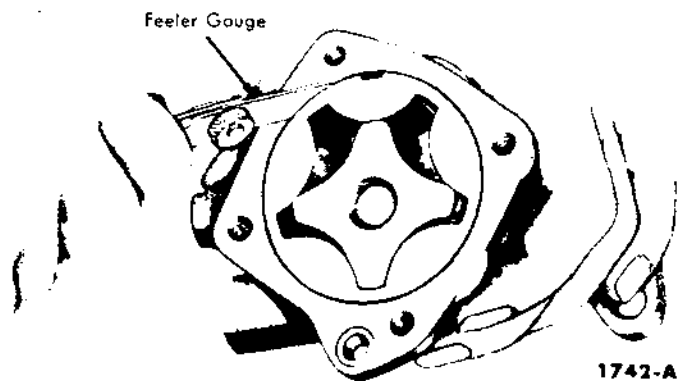

FIG. 82—Outer Race to Housing Clearance

up when bored for the maximum oversize piston recommended, replace the block.

Rebore the cylinder to within approximately 0.0015 inch of the required oversize diameter. This will allow enough stock for the final step of honing so the correct surface finish and pattern are obtained. Use clean sharp hones of No. 220-280 grit for this operation.

For the proper use of the boring equipment follow the instructions of the manufacturer. Only experienced personnel should be allowed to perform this work.

After the final operation in either of the two refinishing methods described and prior to checking the piston fit, thoroughly wash the cylinder walls with solvent to remove all abrasive particles, then thoroughly dry the walls. Check the piston fit (page 1-36). Mark the pistons to correspond to the cylinders in which they are to be installed. When the refinishing of all cylinders that require it has been completed and all pistons fitted, thoroughly clean the entire block to remove all particles from the bearing bores, oil passages, cylinder head bolt holes, etc. Coat the cylinder walls with oil.

foreign matter is removed from below the baffle plate.

Check the pan for cracks, holes, damaged drain plug threads, a loose baffle, and a nicked or warped gasket surface.

Repair any damage, or replace the pan if repairs can not be made.

#### OIL PUMP

Wash all parts in a solvent and dry them thoroughly. Use a brush to clean the inside of the pump housing and the pressure relief valve chamber. Be sure all dirt and chips are removed.

Check the inside of the pump housing and the outer race and rotor for damage or excessive wear.

Check the mating surface of the pump cover for wear. If the cover mating surface is worn, scored, or grooved, replace the cover.

Measure the outer race to housing clearance (Fig. 82).

With the rotor assembly installed in the housing, place a straight edge over the rotor assembly and the housing. Measure the clearance between the straight edge and the rotor and outer race (Fig. 83).

**The outer race, shaft and rotor are replaceable only as an assembly.**

Check the drive shaft to housing bearing clearance by measuring the O.D. of the shaft and the I.D. of the housing bearing.

Inspect the relief valve spring for a collapsed or worn condition.

Check the relief valve spring tension. If the spring tension is not within specifications and/or the spring is defective, replace the spring.

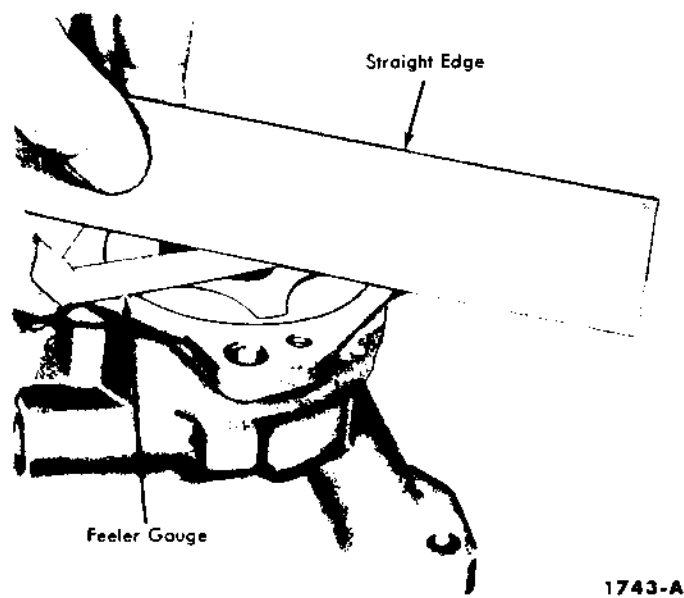

FIG. 83—Rotor End Play

Check the relief valve piston for scores and free operation in the bore.

## 9 REPAIR OPERATIONS (ENGINE IN CHASSIS)

### ENGINE SUPPORTS

The front supports are located on each side of the crankcase and the rear support is located at the transmission extension housing.

#### ENGINE FRONT SUPPORT

The engine front support is shown in Fig. 84. The procedures given apply to either a right or left installation.

#### Removal

1. Remove the insulator assembly to engine retaining bolts, and insulator to underbody retaining nut and washer.

If only one support is being removed, loosen the other support.

2. Raise the engine about 1-inch with a jack and a block of wood placed under the oil pan, then remove the insulator assembly.

#### Installation

1. Position the insulator assembly. Install, but do not tighten, the insulator to engine lockwashers and bolts. If both supports have been removed, install the bolts on the opposite side before proceeding with step 2.

2. Lower the engine, then install the underbody to insulator lockwasher and nut and tighten the nut to 40-45 foot-pounds torque. Tighten

**AND OIL PUMP**

**100% SATISFACTION GUARANTEED**

**BUY IT NOW!**

**Click Here To Order**

fr  
ol  
SUI  
ar

PayPal

MasterCard

VISA

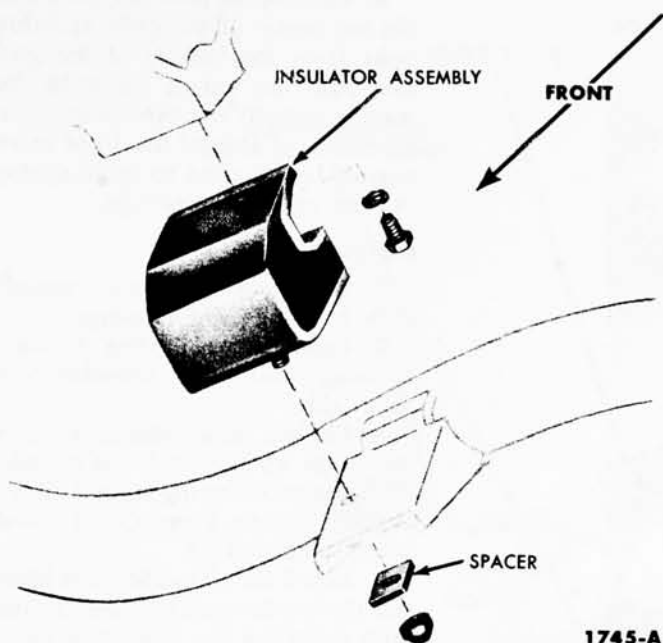

**FIG. 84—Engine Front Support**

the insulator to engine bolts to 35-40 foot-pounds torque.

#### ENGINE REAR SUPPORT

The engine rear support is shown in Fig. 85.

#### Removal

1. Remove the support retainer to extension housing bolts and washers, and remove the support assembly to underbody nuts, lockwashers, and bolts.

2. Raise the extension housing slightly to relieve the pressure on the support assembly to underbody bolts, retainer and support assembly.

#### Installation

1. Raise the extension housing enough to position the support assembly and retainer. Install the support retainer to extension housing flat washers, lockwashers, and bolts, the support assembly to underbody bolts, lockwashers and nuts.

2. Remove the jack from the extension housing, then tighten the support retainer bolts to 25-30 foot-pounds torque, and the support assembly nuts to 40-45 foot-pounds torque.

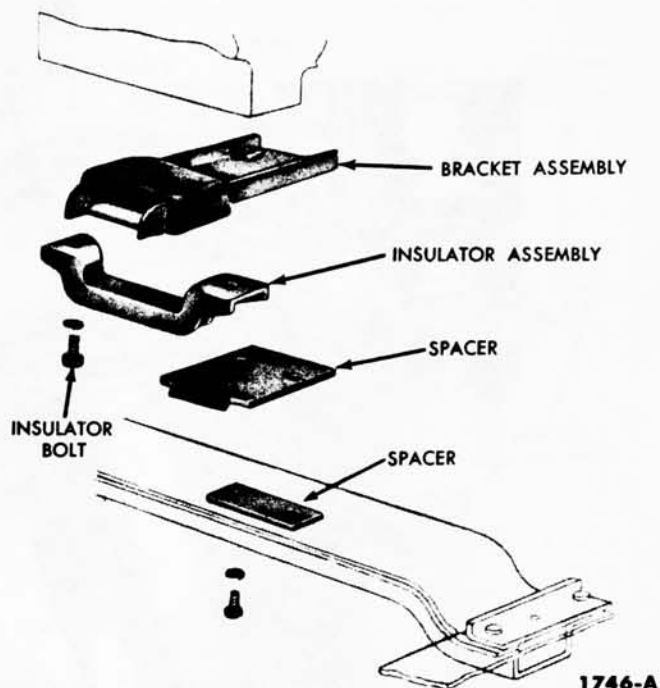

**FIG. 85—Engine Rear Support**

fold. Remove the automatic choke heat tube.

3. Disconnect the accelerator linkage at the carburetor, the windshield wiper flexible line at the vacuum booster, and the booster pump vacuum line at the intake manifold "Tee" fitting. Remove the carburetor fuel inlet line. Disconnect the primary wire at the distributor and the engine temperature sending unit wire at the sending unit.

On cars with power brakes, disconnect the power brake line at the intake manifold and at the flexible line, then release the line from the brackets on the left valve rocker arm cover and remove the line.

Remove the distributor cap and spark plug wire assembly. Disconnect the distributor vacuum line at the distributor. Scribe a line on the distributor housing and manifold to mark the position of the rotor and distributor housing for installation. Remove the distributor hold down bolt and clamp, then remove the distributor. Remove the radiator supply tank. Loosen the by-pass clamp and slide the clamp back. Remove the valve rocker arm covers.

4. Complete the removal procedure by following steps 2 and 3 under Intake Manifold (page 1-16).

#### INSTALLATION

1. Follow steps 2, 3, 4, and 5 under Intake Manifold (page 1-25).

2. Install the distributor, using the scribed lines as guides to properly position the rotor and housing.

3. Install the radiator supply tank.

4. Connect the heater hose and the radiator upper hose and install the automatic choke heat tube.

5. Connect the windshield wiper flexible line at the vacuum booster. Connect the booster pump vacuum line at the intake manifold. Connect the accelerator linkage. Install the fuel line. Connect the distributor primary wire, and the engine temperature sending unit wire. Install the distributor cap and spark plug wire assembly.

On cars with power brakes, connect the power brake line at the intake manifold and to the flexible line.

6. Fill and bleed the cooling system. Connect the heater hose. Start the engine. Adjust the ignition timing and check all hose connections and gaskets for leaks. Connect the distributor vacuum line. Install the valve rocker arm covers and install the spark plug wires in the brackets on the covers. Be sure the spark plug wires for No. 7 and 8 cylinders are properly positioned in the brackets. See Fig. 9 on page 1-48. Position the wire loom in the retaining clips on the left valve rocker arm cover. Install the air cleaner.

On cars with power brakes, install the power brake line in the retaining clips on the left valve rocker arm cover.

**INTAKE MANIFOLD**

**100% SATISFACTION GUARANTEED**

**BUY IT NOW!**

**Click Here To Order**

PayPal, American Express, Discover, MasterCard, VISA



FIG. 86—Oil Filter Replacement

## CYLINDER HEADS

### REMOVAL

1. Drain the cooling system. Remove the air cleaner. Remove the intake manifold and carburetor as an assembly. Remove the exhaust manifolds and the spark plugs.

If the left cylinder head is to be removed, remove the ignition coil.

2. Remove the cylinder head bolts, then install the cylinder head holding fixture (Fig. 21). Lift the cylinder head off the block. **Do not pry between the head and the block.** Remove the cylinder head gasket.

### INSTALLATION

1. Follow steps 1, 2, 3 under Cylinder Head on page 1-24.

2. Install the intake manifold, the exhaust manifolds, and the spark plugs. Connect the spark plug wires.

## CYLINDER FRONT COVER AND TIMING CHAIN

### REMOVAL

1. Drain the cooling system and the crankcase. Remove the hood, air cleaner, radiator, fuel pump, radiator

shaft sprockets (Fig. 38). Remove the camshaft thrust button and spring, the sprocket cap screw, the thrust button spring retainer, and the fuel pump eccentric. Remove the sprockets and timing chain as an assembly (Fig. 24).

### INSTALLATION

1. Follow steps 1 thru 4 under "Timing Chain and Sprockets" on page 1-22.

2. Replace the crankshaft front oil seal (page 1-23).

3. Install the cylinder front cover following steps 1 thru 4 under "Cylinder Front Cover Installation" (page 1-24).

4. Install the crankshaft damper. Install the water pump, pulley, and fan as an assembly. Install the oil pan. Install and adjust the drive belt(s). Install the fuel pump, the radiator supply tank, and the hood. Fill and bleed the cooling system. Fill the crankcase. Start the engine and adjust the ignition timing. Operate the engine at fast idle and check all hose connections and gaskets for leaks.

## CAMSHAFT

### REMOVAL

1. Follow steps 1 and 2 under "Cylinder Front Cover and Timing Chain Removal" in this section.

2. Follow steps 3 and 4 under "In-

take Manifold" on page 1-41.

3. Remove the retaining bolts from the top center of the grille and three bolts from the bottom of the grille and push the top of the grille forward. Carefully remove the camshaft by pulling it toward the front of the engine. Use caution to avoid damaging the camshaft bearings.

### INSTALLATION

1. Oil the camshaft and carefully slide it through the bearings.

2. Follow steps 1 thru 3, under "Timing Chain and Sprockets" on page 1-22.

3. Replace the crankshaft front oil seal (page 1-23). Install the cylinder front cover, following steps 1 thru 7 under "Cylinder Front Cover Installation" on page 1-24.

4. Install the hydraulic valve lifters and the intake manifold and related parts following the procedure under "Intake Manifold" on page 1-25.

5. Install the oil pan, the radiator, the radiator supply tank, the hood, and the air cleaner. Fill and bleed the cooling system. Fill the crankcase. Start the engine and adjust the ignition timing.

## OIL PAN AND OIL PUMP

### REMOVAL

1. Drain the cooling system and the crankcase. Disconnect the radiator upper hose at the radiator supply tank. Remove the oil pan retaining screws and lower the oil pan to the underbody cross member. Position the crankshaft so the counterweight will clear the oil pan and move the pan forward.

2. Remove the coil retaining bolts and position the coil out of the way. Install the engine lifting brackets and sling. Raise the engine high enough to place tension on the engine mounts. Remove the engine front insulator to engine retaining bolts. Raise the engine high enough to permit removal of the oil pump retaining bolts, then remove the bolts. Remove the oil pan and the oil pump.

### INSTALLATION

1. Raise the engine enough to allow installation of the oil pump and the oil pan. Position a new gasket on the oil pump housing and on the oil pan. Place the oil pump in the oil pan and position the oil pan on the underbody cross member. Insert the oil pump drive shaft into the oil pump housing and install the oil pump and shaft as an assembly. **Do not attempt**

ret  
ind  
sha  
ing

**100% SATISFACTION GUARANTEED**

**BUY IT NOW!**

**Click Here To Order**

PayPal   American Express   Discover   MasterCard   VISA

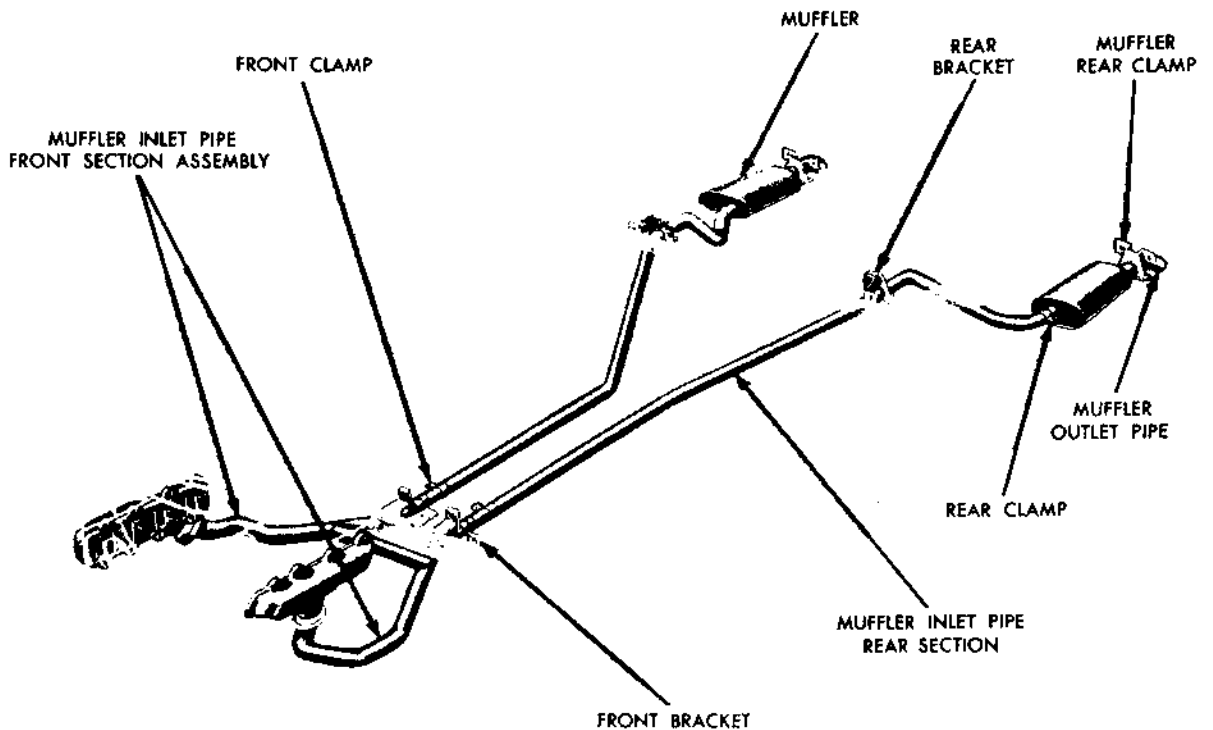

1747-A

FIG. 87--Exhaust System

to force the pump into position if it will not seat readily. The drive shaft hex may be misaligned with the distributor shaft. To align, rotate the intermediate shaft into a new position. Tighten the oil pump retaining screws to 23-28 foot-pounds torque.

2. Hold the oil pan in place against the cylinder block and install a retaining screw on each side of the oil pan. Install the remaining screws and tighten them from the center outward to 12-15 foot-pounds torque.

3. Lower the engine, then install the engine right and left front support retaining bolts. Tighten the bolts to 40-45 foot-pounds torque. Remove the engine lifting bracket and sling. Install the coil and connect the radiator upper hose. Fill the cooling system. Fill the crankcase with the proper grade and quantity of engine oil. Operate the engine and check for leaks.

tion on the adapter (Fig. 86). Hand tighten the filter until the gasket contacts the adapter face, then advance it  $\frac{1}{2}$ -turn.

3. Operate the engine at fast idle and check for leaks. If oil leaks are evident, perform the necessary repairs to correct the leakage. Check the oil level and fill the crankcase if necessary.

### EXHAUST SYSTEM

The exhaust system is shown in Fig. 87.

#### MUFFLER INLET PIPE REPLACEMENT

The right and left muffler inlet pipe front sections are serviced as one piece.

1. Loosen the muffler inlet pipe front support clamp bolt and slide the clamp off the support. Disconnect the inlet pipes at the exhaust manifolds. Remove the muffler inlet pipe assembly. Remove the exhaust gas control valve from the right exhaust manifold and discard the gaskets.

2. Position the clamp on the front section of the new inlet pipe. Connect the front and rear sections. Place a new gasket on the exhaust manifolds, then position the exhaust gas control

valve on the right exhaust manifold. Position a new gasket on the exhaust gas control valve. Position the inlet pipe assembly on the exhaust manifold studs and on the extension of the mufflers. Slip the front clamp into place. Connect the inlet pipe to the exhaust manifolds and tighten the nuts to 23-28 foot-pounds torque. Align the inlet pipe assembly and tighten the clamps.

#### MUFFLER AND OUTLET PIPES

The procedure applies to either a right or left assembly.

1. Loosen the muffler inlet pipe rear clamp, then spread the clamp and slide it off the muffler. Remove the lower half of the muffler rear clamp. Remove the muffler from the inlet pipe.

2. Position the new muffler and outlet pipe assembly on the inlet pipe. Slide the muffler forward into the inlet pipe until the slots in the muffler extension are blocked. The overlap must not be greater than  $1\frac{3}{4}$  inches. Align the muffler and outlet pipe assembly. Position the muffler inlet pipe clamp and install the retaining bolts. Install the muffler rear clamp.

**FILTER**

**100% SATISFACTION GUARANTEED**

**BUY IT NOW!**

**Click Here To Order**

PayPal, American Express, Discover, MasterCard, VISA

**PART 2 IGNITION SYSTEM**

Section	Page
1 Trouble Shooting .....	1-44
2 Ignition System Testing .....	1-45
3 Distributor Tests, Adjustments, and Minor Repairs .....	1-49
4 Distributor Overhaul .....	1-52

The purpose of the ignition system is to transform low voltage electricity from the electrical supply system to surges of high voltage electricity and to distribute this high voltage to the proper spark plug at the right time.

The ignition system consists of a primary (low voltage) and a secondary (high voltage) circuit (Fig. 1). The battery, ignition switch, primary circuit resistor, primary windings of the ignition coil, breaker points, and the condenser are in the primary circuit. The secondary circuit is composed of the secondary windings of the ignition coil, distributor rotor, distributor cap, high tension wires, and the spark plugs.

When the breaker points are closed, the primary or low voltage current flows from the battery through the ignition switch to the primary windings in the coil, then to ground through the closed breaker points. When the breaker points open, the magnetic field built up in the primary windings of the coil moves through the secondary windings of the coil producing high voltage current. **High voltage current is produced each time the breaker points open.** The high voltage flows through the coil high tension lead to the distributor cap where the rotor distributes it to one of the spark plug terminals in the distributor cap. This process is repeated for every power stroke of the engine.

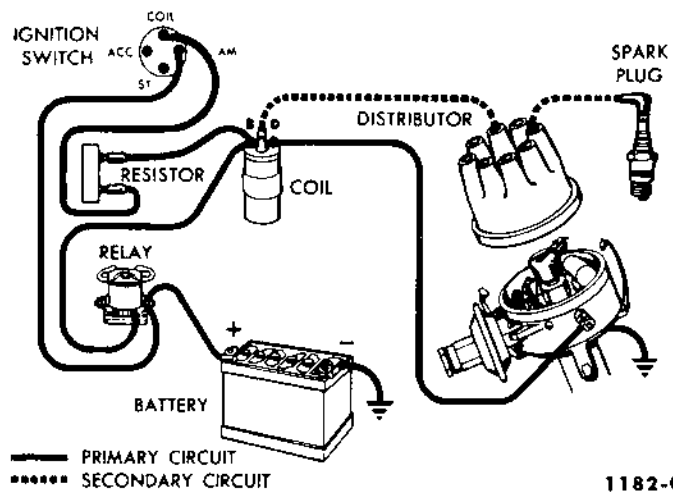

**FIG. 1—Ignition Circuit**

1182-C

**1 TROUBLE SHOOTING**

Ignition system troubles are caused by a failure in the primary and/or the secondary circuit, or incorrect ignition timing.

**PRIMARY CIRCUIT**

A break down or energy loss in the primary circuit can be caused by:

1. Defective primary wiring.
2. Burned breaker points or improperly adjusted breaker points.
3. A defective coil, resistor, or condenser.

**SECONDARY CIRCUIT**

A break down or energy loss in the secondary circuit can be caused by:

1. Fouled or broken spark plugs, or plugs incorrectly adjusted.
2. Defective high tension wiring.
3. High-tension leakage across the coil, distributor cap, or rotor.

**IGNITION TIMING**

Incorrect ignition timing can be caused by:

1. Timing incorrectly adjusted.
2. Distributor bushing and/or shaft worn, or a bent distributor shaft.
3. Defective vacuum advance system.
4. Defective centrifugal advance.
5. Preignition (caused by spark plugs of the wrong heat range), improperly adjusted plugs, etc.

If the cause of engine trouble has been traced to the ignition system (page 1-7), refer to the trouble in Table 1 and check the items listed under the trouble. The causes of the troubles are listed in the order of their probable occurrence; therefore, the items should be checked in the order listed.

**TABLE 1—Ignition System Trouble Shooting**

<p><b>ENGINE CRANKS BUT WON'T START</b></p> <p><b>BUY IT NOW!</b></p> <p><b>Click Here To Order</b></p>	<p>To determine if the cause of the trouble is in the primary or the secondary circuit, pull the coil wire from the top of the distributor and hold it approximately 3/16 inch from the cylinder head, then with the ignition on and the engine turning over, check for a spark. If the spark is good, check the ignition timing.</p> <p>If the spark is good and the ignition timing is not at fault, the cause of the trouble is probably in the:</p> <ul style="list-style-type: none"> <li>Distributor cap.</li> <li>Rotor.</li> <li>Spark plug wires.</li> </ul> <p>If there is no spark or a weak spark, the cause of the trouble is probably in the:</p> <ul style="list-style-type: none"> <li>Primary circuit.</li> <li>Coil to distributor high tension lead.</li> <li>Coil.</li> </ul>
---	---

TABLE 1—Ignition System Trouble Shooting (Cont'd.)

<b>ENGINE STARTS, BUT FAILS TO KEEP RUNNING</b>	Check the: Breaker points. Spark plugs.	Resistor for an open circuit.  Check for leaks in the high tension wiring.
<b>ENGINE RUNS, BUT MISSES</b>	<b>MISSES STEADY AT ALL SPEEDS.</b> If the miss is isolated in a particular cylinder, perform a spark test on the ignition lead of that cylinder. If a good spark does not occur, the trouble is in the secondary circuit of the system, check the: Spark plug wire. Distributor cap. If a good spark occurs, check the spark plug. If the spark is not at fault, a mechanical component of the engine is probably at fault. <b>MISSES ERRATICALLY AT ALL SPEEDS.</b> Check the: Breaker points. Condenser.	Secondary wiring. Coil. Spark plugs.  Check for high tension leakage across the coil, rotor, or distributor cap.  <b>MISSES AT IDLE ONLY.</b> Check the: Coil. Condenser. Breaker points. Rotor. Ignition wiring for leakage. Distributor shaft for excessive play. Spark plugs. Distributor cam for wear.
<b>POOR ACCELERATION</b>	Check the: Ignition timing. Spark plugs.	Breaker points. Distributor advance.
<b>ENGINE DOES NOT DEVELOP FULL POWER, OR HAS POOR HIGH SPEED PERFORMANCE</b>	The cause of this trouble usually lies in the ignition system only when the trouble exists at all engine temperatures. Check the: Ignition timing. Coil. Condenser.	Rotor. Distributor advance. Distributor shaft for excessive play. Distributor cam. Spark plugs. Breaker points.
<b>EXCESSIVE FUEL CONSUMPTION</b>	Check the: Ignition timing.	Spark plugs. Distributor advance.
<b>ENGINE OVERHEATING</b>	Check the ignition timing.	

## 2 IGNITION SYSTEM TESTING

A complete check of the ignition system includes the battery and cables, coil, distributor, primary and secondary wiring, and the spark plugs. This section describes the tests for all these units except the battery and the distributor. The battery, because it is part of the electrical supply system, is covered in Group 7, Part 1. Distributor testing is covered in Sec-

and the contacting surfaces on the battery, engine, and relay are clean. Tighten the cables securely upon installation. Test the battery (Group 7, Part 1).

Inspect all the primary wiring for worn insulation, broken strands, and loose or corroded terminals. Replace any defective wiring. Make sure all connections are tight. Remove the coil to distributor high tension lead and the spark plug wires one at a time from the distributor cap and from the spark plugs. Inspect the terminals for looseness and corrosion. Inspect the wires for breaks and cracked insulation. Replace all defective wiring.

Clean the inside of the distributor cap, and inspect it for cracks, burned contacts, or permanent carbon tracks. Remove dirt or corrosion from the sockets. Inspect the rotor for cracks or a burned tip. Replace the cap and/or rotor if they are defective.

### PRIMARY CIRCUIT RESISTANCE TEST

A complete test of the primary circuit consists of checking for excessive voltage drop from the battery to the coil and from the coil to ground. Excessive voltage drop in the primary circuit will lessen the secondary output of the ignition coil, resulting in hard starting and poor performance.



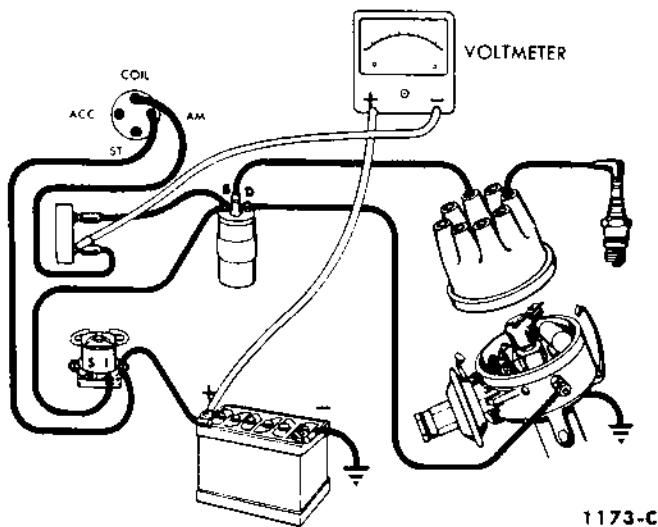

1173-C

FIG. 2—Battery to Resistor Test

The following tests are made with the ignition switch on and the breaker points closed.

#### BATTERY TO COIL TEST

Check the voltage at the battery terminal of the coil. If the voltage is below 8.5 volts, it will be necessary to make the following checks to determine the point of high resistance in the battery to coil circuit.

Connect the negative lead of a voltmeter to the battery terminal of the resistor and the positive lead to the positive terminal of the battery (Fig. 2).

If the voltage drop is 0.2 volts or less, the primary circuit from the battery to the resistor is satisfactory. If the voltage drop exceeds this limit, leave the positive lead of the voltmeter connected to the positive terminal of the battery and touch the voltmeter negative lead to the coil terminal of the ignition switch (Fig. 3). If there is no change in the reading, the circuit is satisfactory. Next, touch the voltmeter negative lead to the battery terminal of the ignition switch (Fig. 3). If the reading drops, there is excessive resistance in the switch.

Check the primary resistor by connecting an ohmmeter across its terminals (Fig. 4). **Disconnect the battery wire at the resistor to prevent damage to the ohmmeter.** The specified resistance is 1.3-1.4 ohms. If the reading is under this limit replace the

tension lead at the coil and crank the engine while observing the voltage drop. It should not exceed 0.1 volt. If the voltage drop is excessive, clean and tighten the terminals or replace wiring as necessary.

#### BATTERY TO GROUND TEST

Connect the positive lead of the voltmeter to the distributor terminal of the coil, and the negative lead to ground. The voltage drop should not exceed 0.1 volt. If the voltage drop is excessive, test the voltage drop of each of the following:

1. Coil to distributor wire.
2. Distributor primary terminal and the movable breaker point.
3. The movable breaker point and the breaker plate.
4. The breaker plate and the distributor housing.
5. The distributor housing and engine ground.

#### SPARK INTENSITY

Disconnect one spark plug wire at a time and install a terminal adapter in the wire terminal. Hold the adapter approximately  $\frac{3}{16}$  inch from the exhaust manifold and crank the engine. The spark should jump the gap regularly.

If the spark intensity of all leads is satisfactory, the coil, condenser, rotor, distributor cap, and the high tension cables are probably satisfactory.

If the spark is good at only some leads, perform a high resistance test of the faulty leads.

If the spark is equal at all leads, but weak or intermittent, make a high resistance check of the coil, distributor cap, and the coil to distributor

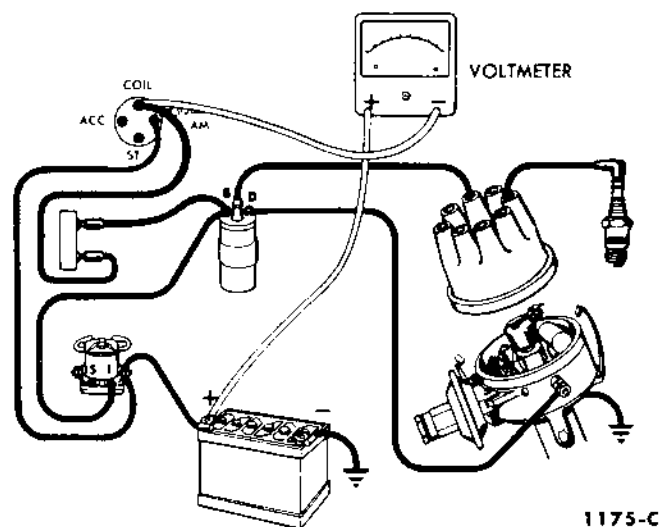

1175-C

FIG. 3—Battery to Switch Test

high tension lead. Follow the instructions of the test set manufacturer when making the test.

#### COIL

Coil tests can be made with the coil installed on the engine or on a test set. The coil tests include coil heat, secondary continuity, and coil capacity.

A coil may break down after it has reached operating temperature; therefore, a coil heat test is made to test the coil at operating temperature. The coil secondary continuity test is performed to test the coil secondary windings for high resistance. The coil capacity test is made to determine the condition of the windings of the coil.

Perform all tests following the instructions of the test set manufacturer.

#### REMOVAL

Disconnect the high tension lead and the primary leads from the coil. Remove the coil mounting screws and remove the coil.

#### INSTALLATION

Place the coil in position and install the mounting screws. Insert the high tension lead into the coil socket. Push the weather seal tight against the socket. Connect the primary wires to the coil. Be sure the wires are properly installed.

#### RESISTOR

The resistor (Fig. 6) is checked for excessive resistance as previously explained under "Battery To Coil Test."

#### SPARK PLUGS

An 18-millimeter spark plug (Fig. 7) is used. This plug does not require a gasket.

100% SATISFACTION GUARANTEED

**BUY IT NOW!**

Click Here To Order

PayPal American Express Discover.com Visa MasterCard

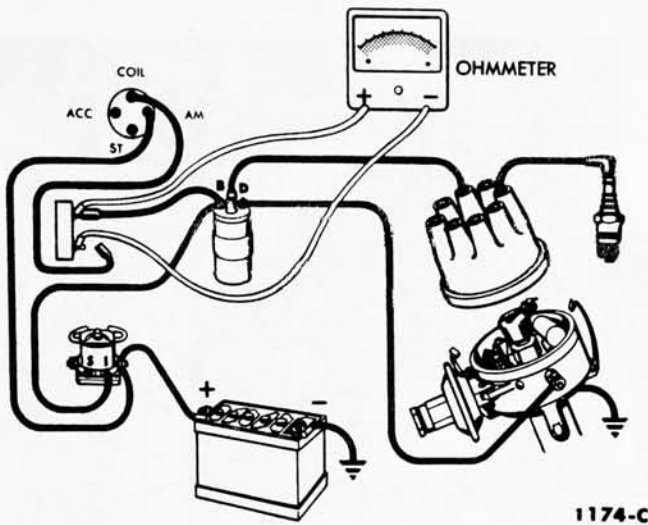

FIG. 4—Resistor Test

1174-C

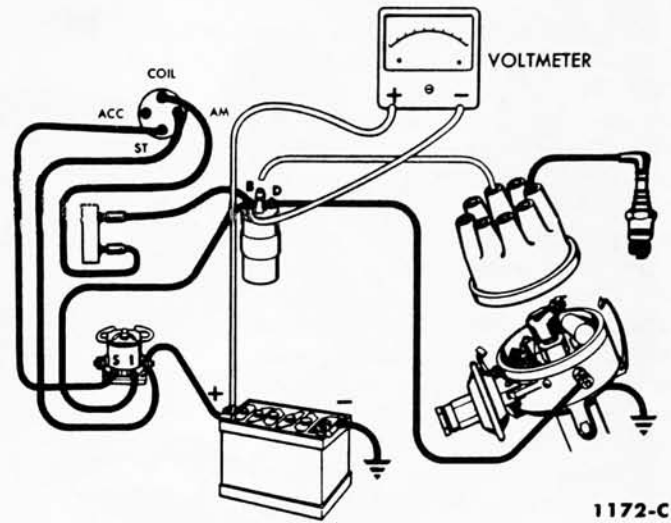

FIG. 5—Starting Ignition Circuit Test

1172-C

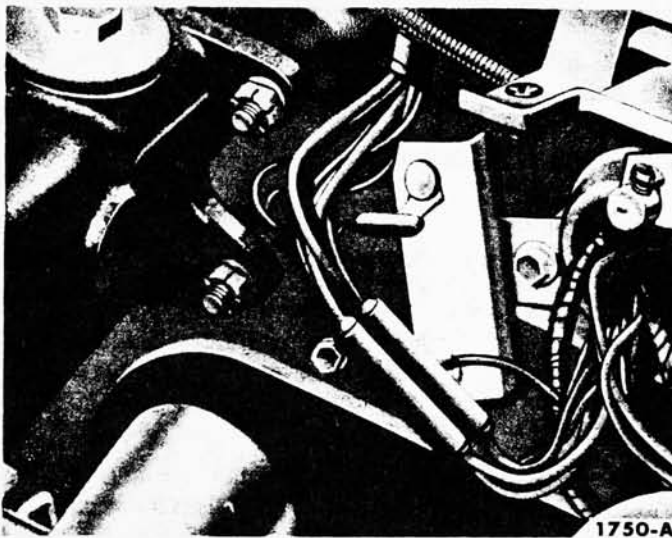

FIG. 6—Resistor

1750-A

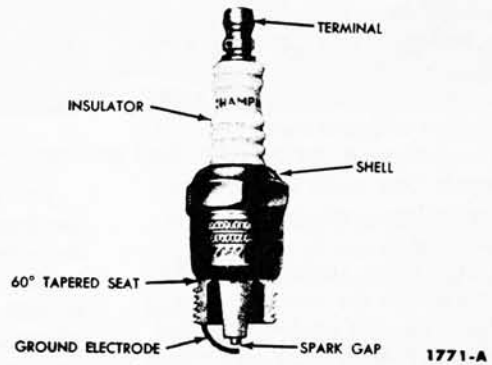

FIG. 7—18-Millimeter Spark Plug

1771-A

**REMOVAL**

Pull the wire off each spark plug, and clean the area around each spark plug with compressed air, then remove the spark plugs.

**CLEANING AND INSPECTION**

Examine the firing ends of the spark plugs, noting the type of deposits and the degree of electrode erosion. The various types of spark plug fouling and the normal condition of the spark plug after usage are shown in Fig. 8.

Oil fouling (Fig. 8) is usually identified by wet, sludgy deposits. These are traceable to excessive oil entering the combustion chamber through worn rings and pistons, excessive clearance between the valve guides and stems, or worn or loose bearings.

Gas fouling (Fig. 8) is usually identified by dry, black, fluffy deposits which result from incomplete combustion. Too rich a fuel-air mixture can cause incomplete burning. In addition, a defective coil, defective breaker points, or a defective ignition cable can reduce the voltage sup-



NORMAL CONDITIONS  
1179-B

**100% SATISFACTION GUARANTEED**

**BUY IT NOW!**

**Click Here To Order**

plied to the spark plug and cause misfiring.

Burned or overheated spark plugs (Fig. 8) are usually identified by a white, burned, or blistered insulator nose and badly eroded electrodes. Inefficient engine cooling, improper ignition timing, the wrong type of fuel, or loose spark plugs can cause general overheating.

Normal conditions (Fig. 8 left) where regular or unleaded gasolines have been used are usually identified by a rusty-brown to grayish-tan, powdery deposit and minor electrode erosion, indicating proper ignition and combustion conditions.

Normal conditions (Fig. 8 right) where highly leaded gasolines have been used are usually identified by white, powdery deposits. If the spark plugs are cleaned at recommended intervals and normal service conditions are encountered, these deposits have little effect on plug performance. However, prolonged high-speed, high load operation will fuse these deposits to form a yellowish glaze. At high temperatures, this glaze may be conductive, resulting in spark plug "missing" or fouling.

Clean the plugs on a sand blast cleaner, following the manufacturer's instructions. **Do not prolong the use of the abrasive blast as it will wear the insulator.** Remove carbon and other deposits from the threads with a stiff wire brush. These threads are the means of carrying the heat away from the spark plug. Any deposits will retard the heat flow from the spark plug to the cylinder head, causing spark plug overheating and pre-ignition.

Clean the electrode surface with a small file. Dress the electrodes to secure flat parallel surfaces on both the center and side electrode. **Do not file the ground electrode too thin as pre-ignition may result.**

After cleaning, examine the plug carefully for cracked or broken insulators, badly pitted electrodes, or other signs of failure. Replace as required.

#### ADJUSTMENT

Set the spark plug gap (0.032-0.036 inch) by bending the ground

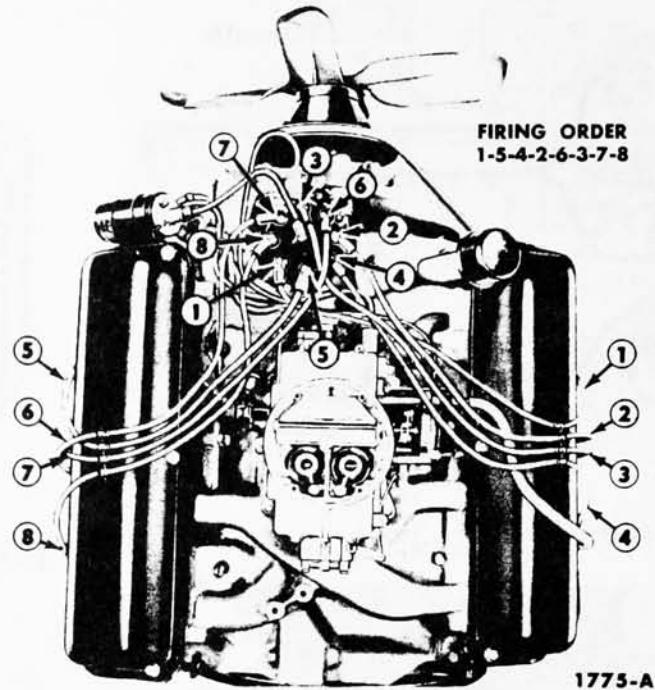

FIG. 9—Ignition Wiring Installation

Test for compression leakage at the insulator seal. Apply a coating of oil to the shoulder of the plug where the insulator projects through the shell, and to the top of the spark plug, where the center electrode and terminal project from the insulator. Place the spark plug under pressure. Leakage is indicated by air bubbling through the oil. If the test indicates compression leakage, replace the spark plug. If the spark plug is satisfactory, wipe it clean.

#### INSTALLATION

Clean the area around the spark plug port to insure proper seating. Install the spark plugs, then tighten them to 15-20 foot-pounds torque.

#### HIGH TENSION (SECONDARY) WIRES

The high tension wires include the wires connecting the distributor cap to the spark plugs and the wire connecting the center terminal of the distributor cap to the center terminal of the ignition coil.

The high tension wires are the radio resistance-type which filter out the high frequency electrical impulses that are the source of ignition noise interference. The wires can be identified by the words "Radio Resistance" stamped on each cable. The resistance of each wire should not exceed 24,500 Ohms. **When checking the resistance of the wires or when setting ignition timing, do not puncture the wires**

**with a probe. The probe may cause a separation in the conductor. A spark plug wire set is available for service.**

At regular intervals, clean and inspect the wires for cracked insulation and loose terminals. Repair or replace the wires as required.

#### REMOVAL

Disconnect the wires from the spark plugs and distributor cap. **To remove the wires from the spark plugs, grasp the molded cap only. Do not pull on the wire as this may separate the wire connection inside the cap or damage the weather seal.** Pull the wires from the brackets on the valve rocker arm covers and remove the wires.

#### INSTALLATION

1. Insert each wire in the proper distributor cap socket. Be sure the wires are forced all the way down into their sockets. The No. 1 socket is identified on the cap. Install the wires in a counterclockwise direction in the firing order (1-5-4-2-6-3-7-8) starting at the No. 1 socket. Cylinders are numbered from front to rear-right bank, 1-2-3-4; left bank, 5-6-7-8.

2. Remove the brackets from the old spark plug wire set and install them on the new set in the same relative position. Install the wires in the brackets on the valve rocker arm covers (Fig. 9), then connect the wires to the proper spark plugs. Install the coil high tension lead. **Be sure No. 7**

**100% SATISFACTION GUARANTEED**

**BUY IT NOW!**

**Click Here To Order**

PayPal | American Express | Discover | MasterCard | VISA

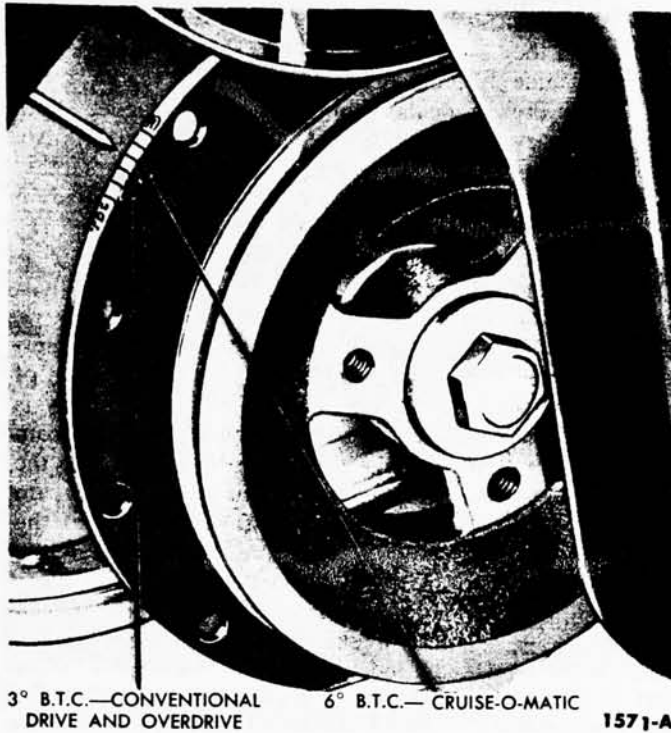

FIG. 10—Timing Marks

spark plug wire is positioned in the brackets as indicated in Fig. 9.

#### IGNITION TIMING

The engine has a crankshaft damper having five timing marks (Fig. 10). The first long mark represents top dead center (T.D.C.) and each succeeding mark represents 2°, 4°, 6°, 8°, 10°, respectively, before top center (B.T.C.). The initial timing should be set at 3° B.T.C. on conventional drive or overdrive units and 6° B.T.C. on cars with Cruise-O-Matic.

#### CHECKING TIMING WITH A TIMING LIGHT

1. Disconnect the distributor vacuum line, then connect the timing light high tension lead to the No. 1

spark plug and the other two leads of the timing light to the battery terminals.

2. Clean the dirt from the timing marks, and if necessary, chalk the proper mark and the pointer to improve legibility.

3. Operate the engine at idle speed. Be sure the engine is idling below 550 rpm so that there will be no centrifugal advance. The timing light should flash just as the proper mark lines up with the timing pointer, indicating correct timing. The operator's eye should be in line with the center of the damper and the timing pointer.

4. If the proper timing mark and the timing pointer do not line up, rotate the distributor until the correct mark and the pointer are in line (Fig.



FIG. 11—Checking Ignition Timing

11). The timing is advanced by clockwise rotation of the distributor body, and retarded by counterclockwise rotation.

5. After the ignition timing has been properly set, connect the distributor vacuum line, then check the distributor to determine if the advance mechanism is operating. To do this, hold the timing light so that the timing marks and pointer can be seen, and accelerate the engine. If no advance is evident, one of the following is the probable cause; no vacuum available at the distributor, vacuum advance diaphragm leaking or disconnected from the breaker plate, centrifugal advance not functioning properly, breaker plate binding in the housing or on the bushing.

### 3 DISTRIBUTOR TESTS, ADJUSTMENTS, AND MINOR REPAIRS

This section covers the tests, adjustments, and minor repairs for the distributor.

indicated.

#### DIAPHRAGM LEAKAGE AND FREENESS OF OPERATION

These tests can be made with the distributor installed on the engine or on a distributor test set. The tests are sufficient for an engine tune-up. However, if there are indications that the spark advance is not functioning properly, remove the distributor from

the engine and check it on a distributor test set following the instructions under "Spark Advance Tests and Adjustments."

Check the vacuum advance mechanism for freeness of operation by manually rotating the breaker plate in the direction of rotation. Do not rotate the plate by pushing on the condenser or the points, use a hook or other suitable instrument in the

**SPARK ADVANCE CONTROL SYSTEM**

**100% SATISFACTION GUARANTEED**

**BUY IT NOW!**

**Click Here To Order**

PayPal, American Express, Discover, MasterCard, VISA

**breaker point and adjustment slot.**

The breaker plate should turn without binding and return to its original position when released. If the breaker plate binds, remove the plate. Clean, inspect, and lubricate the distributor.

To check the diaphragm for leakage:

Adjust the vacuum gauge to read the highest vacuum possible following the instructions of the test set manufacturer. Install the vacuum hose on the diaphragm vacuum line fitting. The vacuum gauge reading should not fall off when the vacuum is applied to the diaphragm assembly if no leak exists. If a leak is indicated by the test, replace the diaphragm assembly.

**BREAKER PLATE WEAR TEST**

A worn breaker plate will cause the breaker point gap and dwell angle to change as engine speed and load conditions are varied.

Install the distributor on a test set following the instructions of the test set manufacturer. Attempt to "rock" the breaker plate by applying light thumb pressure, alternately, to each side of the breaker plate (movable section or inner race). The test should be repeated with the breaker plate in various positions of its normal travel. If the dwell angle reading changes more than 4 degrees while "rocking" the breaker plate, the bushing should be replaced.

**SPARK ADVANCE TESTS AND ADJUSTMENTS**

The spark advance is checked to determine if the ignition timing advances in proper relation to engine speed and load.

Mount the distributor on a test set and calibrate the test set following the instructions of the manufacturer. Check the dwell angle. If the dwell is not between  $26^{\circ}$ - $28\frac{1}{2}^{\circ}$  or the point gap is not within 0.014-0.016 inch, adjust the points. Check the breaker arm spring tension (17-20 ounces), and adjust it if necessary.

The distributor has two independently operated spark advance systems. Each system is adjusted separately. **Adjust the centrifugal advance before adjusting the vacuum**

speed to where there is no advance and zero the advance scale. Increase the speed to the value specified for the first advance reading listed in the specifications. If the correct advance is not indicated at this rpm, stop the distributor and bend the primary spring bracket to change tension (Fig. 12). Bend the bracket away from the distributor shaft to decrease advance and toward the shaft to increase advance. **The primary spring is the spring that is under tension when the distributor shaft is not rotating. To determine which spring is under tension, insert a hook into the adjusting slot and move each spring. The secondary spring will be under less tension than the primary spring.**

2. Check the minimum advance point again, then operate the distributor at the specified rpm to give an advance just below the maximum. If this advance is not to specifications, stop the distributor and bend the secondary spring bracket to give the correct advance. **The secondary spring is the spring that is not under tension (is slack) when the distributor shaft is not rotating.**

3. Recheck the zero point and the other two points and make adjustments as required. Next, check the advance at all points listed in the specifications. Operate the distributor both up and down the speed range.

**VACUUM ADVANCE**

1. Operate the distributor at 1000 rpm and zero the advance scale. Check the advance at the first vacuum setting given in the specifications. If the advance is incorrect, change the spacing washers between the vacuum chamber spring and nut. After installing or removing the washers, position the gasket in place and tighten the nut. **The addition of a washer will decrease advance and the removal of a washer will increase advance.**

When one point of the curve is adjusted, the others should be checked. **Do not change the original rpm setting when going to a different vacuum setting.** If they are not within limits, it indicates incorrect spring tension or leakage in the vacuum chamber and/or line.

**BREAKER POINTS**

The breaker point assembly consists of the stationary point bracket assembly, breaker arm, and primary wire terminal. The assembly is mounted on the breaker plate as a

unit, and can be replaced without removing the distributor from the engine.

Breaker points should be inspected, cleaned, and adjusted at regular intervals. Points can be cleaned with chloroform and a stiff bristle brush. Replace the breaker point assembly if the contacts are badly burned or excessive metal transfer between the points is evident. Metal transfer is considered excessive when it equals or exceeds the gap setting.

Burned breaker points are generally the result of an accumulation of oil and dirt on the points. This is usually caused by oil bleeding from the distributor base bushing onto the points, by excessive or improper cam lubricant being thrown off onto the points, and/or neglect to clean the points periodically.

Excessive metal transfer between the breaker points is generally caused by incorrect point alignment, voltage regulator setting that is incorrect, a radio condenser installed to the distributor side of the coil, an ignition condenser of improper capacity or extended operation at speeds other than normal.

**REMOVAL**

Disconnect the primary and condenser leads. Remove the screws that secure the breaker point assembly to the breaker plate, then remove the breaker point assembly.

**INSTALLATION**

1. Place the primary and condenser leads on the breaker point assembly primary terminal. Install the lockwasher and nut, then tighten the nut securely.

2. Position the breaker point assembly on the breaker plate, then install the hold down screws. Make sure the ground wire terminal is on the screw furthest from the adjustment slot. Adjust the breaker point gap.

**Breaker Point Gap.** The breaker points can be adjusted with the distributor installed on the engine or on a distributor test set.

**New Breaker Points.** When new breaker points are installed, check the gap with a feeler gauge. Rotate the distributor cam until the rubbing block rests on the peak of a cam lobe. Insert the correct blade of a feeler gauge between the breaker points (Fig. 13). The correct gap should be 0.014-0.016 inch. If the fit is loose or



FIG. 12—Centrifugal Advance Adjustment

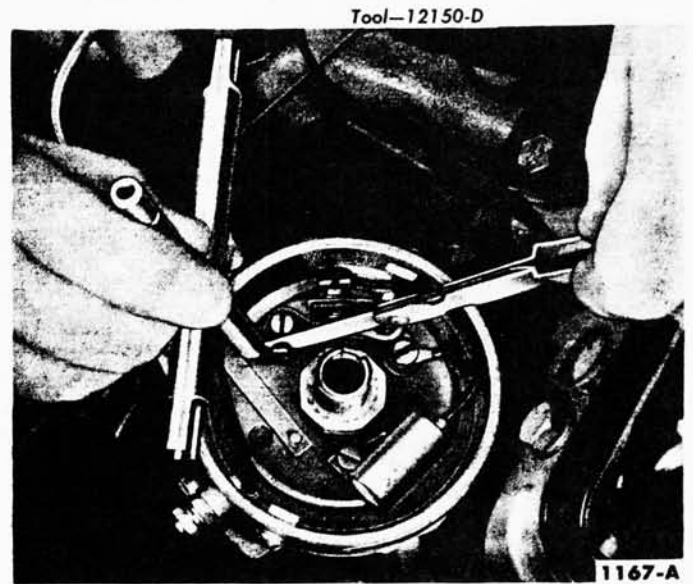

FIG. 13—New Breaker Point Gap Adjustment

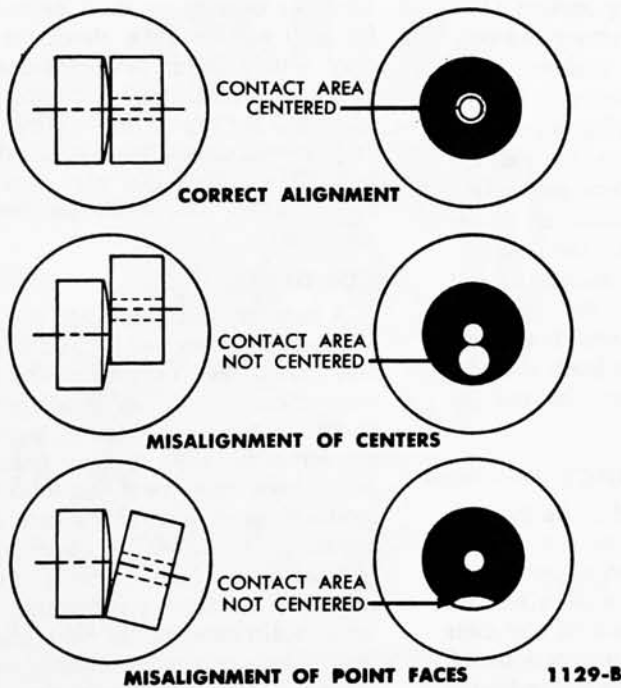

FIG. 14—Breaker Point Alignment



FIG. 15—Aligning Breaker Points

if there is binding, loosen the stationary point lock screw and adjust the breaker point gap (see Fig. 13).

**Used Breaker Points.** If the gap of used breaker points is being checked, use a dwell meter to test the dwell angle. It is not advisable to use a feeler gauge to adjust or to check the gap of used breaker points because the roughness of the breaker points make a gap reading or setting impossible. Check the dwell angle following the instructions of the dwell meter

manufacturer. The dwell angle should be  $26^{\circ}$ - $28\frac{1}{2}^{\circ}$ . Check the point alignment, then set the ignition timing.

**BREAKER POINT ALIGNMENT**

The vented-type breaker points must be accurately aligned and strike squarely in order to realize the full advantages provided by this design, and assure normal point life. Any

**100% SATISFACTION GUARANTEED**

**BUY IT NOW!**

**Click Here To Order**

PayPal, American Express, Discover, MasterCard, VISA

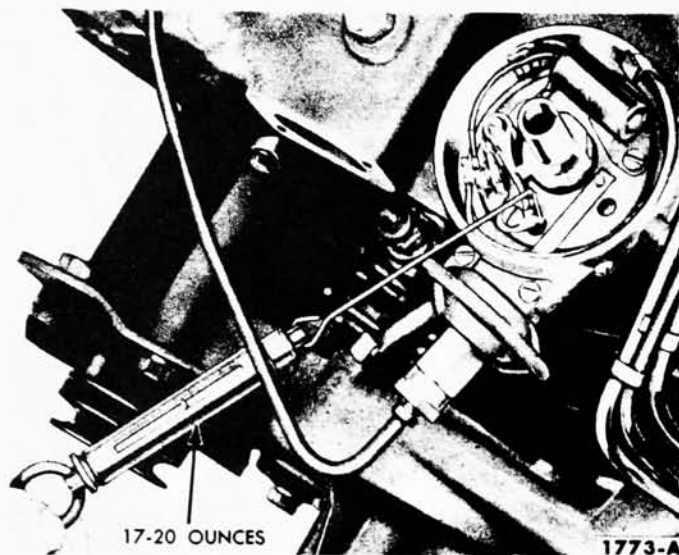

**FIG. 16—Spring Tension**

misalignment of the point surfaces will cause premature wear, overheating and pitting.

Turn the cam so that the breaker points are closed and check the alignment. (Fig. 14). Align the breaker points to make full face contact by bending the stationary breaker point bracket (Fig. 15). **Do not bend the breaker arm.** After the breaker points have been properly aligned, adjust the gap or dwell.

#### BREAKER POINT SPRING TENSION

Correct breaker point spring tension is essential to proper engine operation and normal breaker point life. If the spring tension is too great, rapid wear of the breaker arm rubbing block will result, causing the breaker point gap to close up and retard the spark timing. If the spring tension is too weak, the breaker arm will flutter at high speed, resulting in an engine miss at high rpm.

To check the spring tension, place the hooked end of the spring tension gauge over the movable breaker point, then pull the gauge at a right angle (90°) to the movable arm

until the breaker points just start to open (Fig. 16). If the tension is not within specifications (17-20 ounces), adjust the spring tension.

To adjust the spring tension (Fig. 17), disconnect the primary and condenser leads at the breaker point assembly primary terminal. Loosen the nut holding the spring in position, then move the spring toward the breaker arm pivot to decrease tension and in the opposite direction to increase tension. Tighten the locknut, then check the spring tension. Repeat the adjustment until the specified spring tension is obtained. Install the primary and condenser leads with the lockwasher and tighten the nut securely.

#### CAM LOBE ACCURACY

Worn cam lobes will cause the corresponding cylinders to fire out of time and result in a loss of power.

Install the distributor on a test set and check the accuracy of the cam lobes following the instructions of the manufacturer. If the test indicates that any lobe is worn, replace the cam.

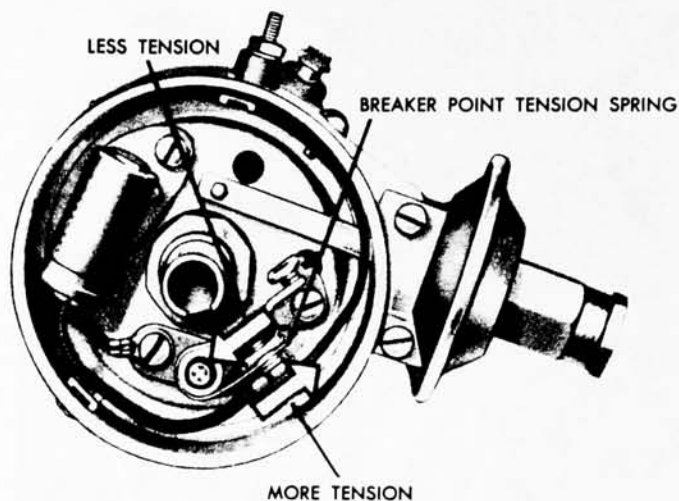

**FIG. 17—Spring Tension Adjustment**

#### DISTRIBUTOR SHAFT END PLAY

Remove the distributor from the engine. Place the distributor in the holding tool and clamp it in a vise. Push the distributor shaft upward as far as it will go, then check the end play with a feeler gauge placed between the centrifugal advance stop plate and the top of the bushing. The end play should be from 0.022-0.030 inch. If the shaft end play is not to specifications, check the location of the collar.

#### CONDENSER

A capacity test, a leakage test, and a series resistance test should be performed on the condenser. The tests can be made with the condenser installed in the distributor or with the condenser installed on a test unit. Use reliable test equipment and follow the instructions of the manufacturer. The capacity is 0.21-0.25 microfarads, leakage should not be greater than 5 megohms at room temperature, and series resistance should be 1 ohm or less. The condenser should be replaced if it does not meet the above specifications.

## 4 DISTRIBUTOR OVERHAUL

ual advance distributor is

**100% SATISFACTION GUARANTEED**

**BUY IT NOW!**

**Click Here To Order**

Dependably operated spark advance

PayPal American Express Cards Discover Novus MasterCard VISA

systems. A governor-type centrifugal advance mechanism is located below the movable breaker plate (Fig. 19), and a vacuum operated spark control diaphragm is located on the side of the distributor base (Fig. 20).

The centrifugal weights cause the

cam to advance or move ahead with respect to the distributor drive shaft. This action causes the cam to open and close the breaker points earlier. The weights turn the cam by means of a stop plate that has two slots which fit over pins in the weights. The

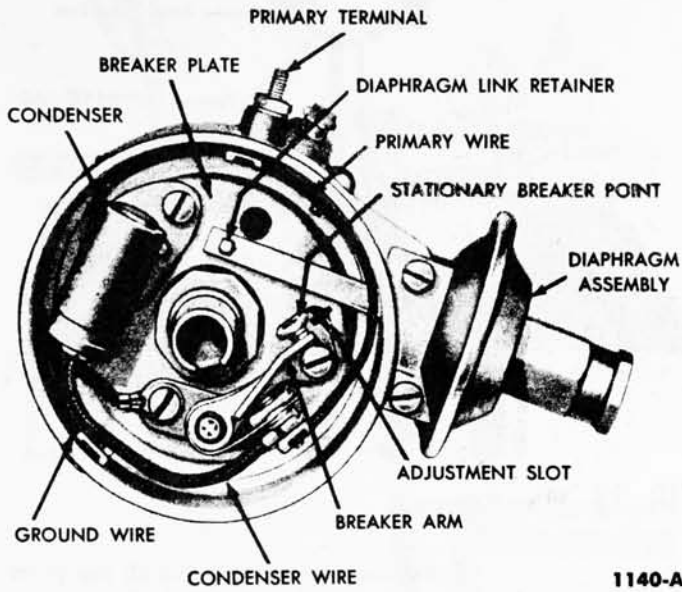

1140-A

FIG. 18—Dual Advance Distributor

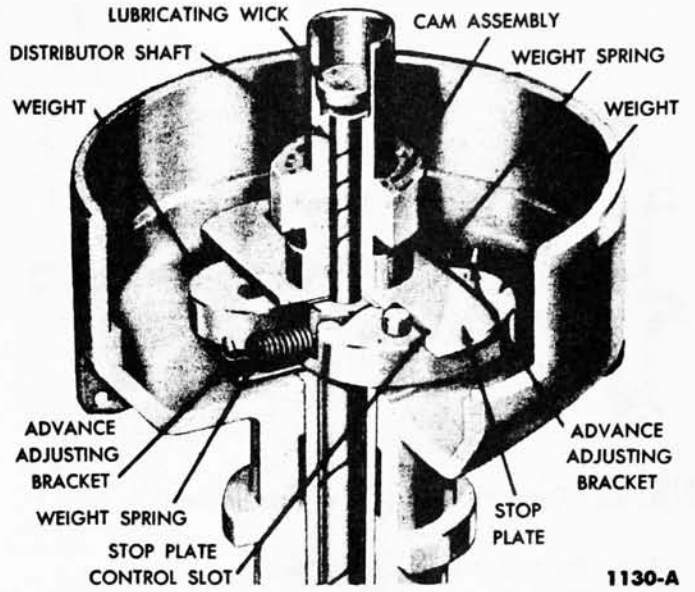

1130-A

FIG. 19—Centrifugal Advance Mechanism

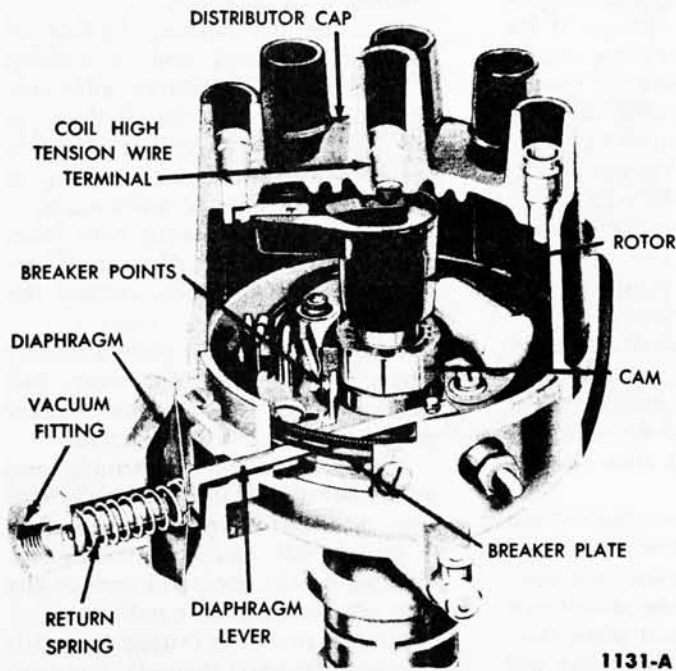

1131-A

FIG. 20—Vacuum Advance Mechanism

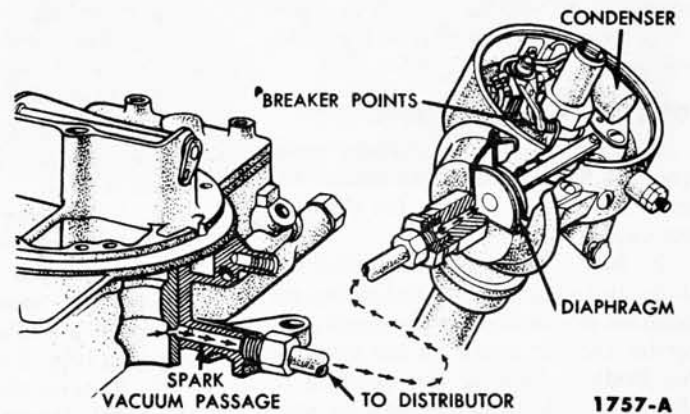

1757-A

FIG. 21—Vacuum Advance Controls

slots determine the maximum amount of advance and the rate of advance in controlled by calibrated springs.

The vacuum advance mechanism has a spring-loaded diaphragm (Fig. 20) which is connected to the breaker points. The spring-loaded side of the

diaphragm to move against the tension of the spring. This action causes the breaker plate to advance and the points open and close earlier.

When the engine is operated under a light load, additional advance is required for maximum part throttle power and economy. Under this condition, engine manifold vacuum is high enough to actuate the diaphragm and advance the spark. At low engine speeds or at idle, a retarded spark is necessary. Because the vacuum pas-

sage opening, in the carburetor, is above the closed throttle plate, there is no vacuum to the diaphragm. The breaker plate is held in a retarded position by the calibrated return spring which bears against the diaphragm.

During acceleration or when there is a heavy load on the engine, there is not enough vacuum to actuate the diaphragm, and the breaker plate once again is held in a retarded position.

**100% SATISFACTION GUARANTEED**

**BUY IT NOW!**

**Click Here To Order**

PayPal, American Express, Discover, MasterCard, VISA

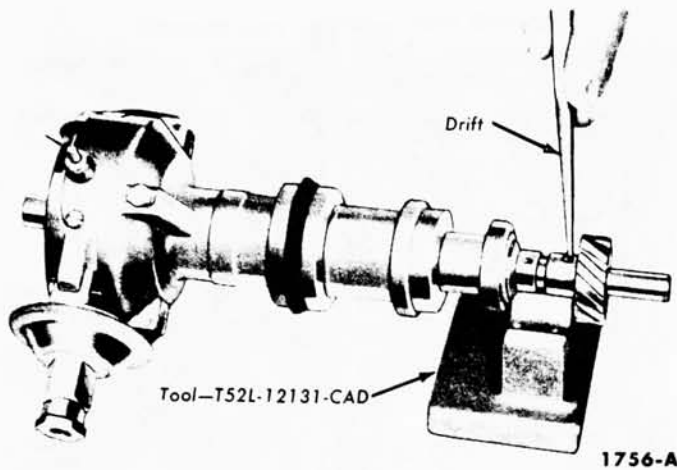

FIG. 22—Gear Pin Removal or Installation

When the engine is being operated under a light load, such as on a level road at 40 mph, and the throttle is suddenly opened further, the manifold vacuum will decrease and the diaphragm spring will quickly force the breaker plate to a retard position. However, the advance provided by the centrifugal mechanism remains unchanged until the engine speed changes. At any particular engine speed, there will be a certain amount of centrifugal advance plus a possible vacuum advance.

### DISTRIBUTOR REMOVAL

1. Disconnect the primary wire and the vacuum advance line at the distributor, and remove the distributor cap.

2. Scribe a mark on the distributor body and engine block indicating the position of the body in the block, and scribe another mark on the distributor body indicating the position of the rotor. These marks can be used as guides when installing the distributor in a correctly timed engine.

3. Remove the distributor hold down cap screw and clamp, then lift the distributor out of the block.

### DISTRIBUTOR DISASSEMBLY

1. Remove the spring clip securing the diaphragm link to the breaker plate, then disconnect the diaphragm assembly from the distributor base and remove the diaphragm assembly.

2. Remove the nut, flat washer, and spring from the primary terminal

assembly.

4. Remove the lubricating wick from the cam assembly, then remove the cam assembly retainer. Remove the cam assembly and the upper thrust washer.

5. Carefully unhook and remove the distributor weight springs. If the two springs are not the same size or are different colors, mark the springs and the brackets to which they are attached. This will eliminate bending the brackets to obtain the correct advance. The weight springs are designated primary (low speed) and secondary (high speed). The secondary spring is the spring which is not under tension.

6. **If the gear and shaft are to be used again, mark the gear and shaft so that the pin holes can be easily aligned for assembly.** Remove the gear roll pin (Fig. 22), then remove the gear (Fig. 23).

7. Remove the shaft collar roll pin (Fig. 24). Invert the distributor and place it on a support plate in a position that will allow the distributor shaft to clear the support plate, then press the shaft out of the collar and the distributor housing (Fig. 25). Remove the distributor shaft bushing (Fig. 26).

### DISTRIBUTOR CLEANING AND INSPECTION

Soak all parts of the distributor assembly (except the condenser, breaker point assembly, lubricating wick, vacuum diaphragm, primary terminal bushing and insulator, and electrical wiring) in a mild cleaning solvent or mineral spirits. **Do not use a harsh cleaning solution.** Wipe all parts that cannot be immersed in a solvent with clean dry rag.

After foreign deposits have been

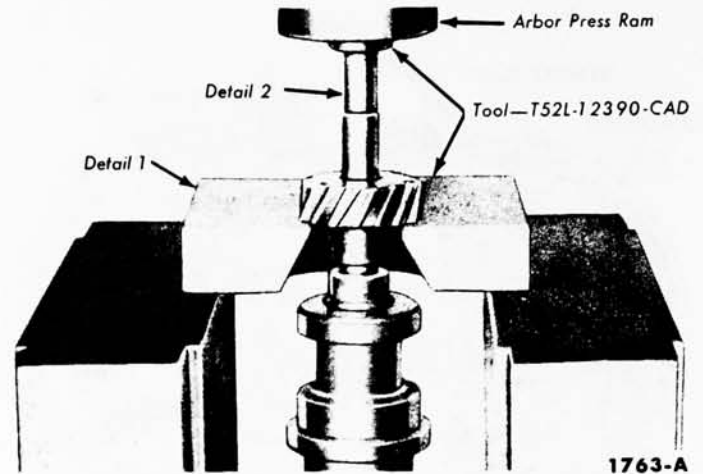

FIG. 23—Gear Removal

loosened by soaking, scrub the parts with a soft bristle brush. **Do not use a wire brush, file or other abrasive object.** Dry the parts with compressed air. Be sure all foreign matter is removed from the ball bearings on the breaker plate assembly.

Examine the bushing surface of the distributor shaft and the bushing for wear. The minimum allowable shaft diameter at the bushing is 0.4675 inch. The maximum allowable inside diameter of the bushing is 0.4690 inch. Replace worn parts.

Inspect the distributor cam lobes for scoring and signs of wear. If any lobe is scored or worn, replace the cam assembly.

Inspect the breaker plate assembly for signs of distortion, worn ball bearings, etc. Replace the breaker plate assembly if it is defective.

The breaker point assembly and condenser should be replaced whenever the distributor is overhauled.

Inspect all electrical wiring for fraying, breaks, etc., and replace any that are not in good condition.

Check the distributor base for cracks, stripped threads, or other damage. Check the diaphragm housing, bracket, and rod for damage. Check the mounting hole and vacuum line fitting threads for stripping or other damage. Test the vacuum fittings, case, and diaphragm for leakage as explained under "Distributor Tests, Adjustments, and Minor Repair." Replace all defective parts.

### DISTRIBUTOR ASSEMBLY

Refer to Fig. 27 for the correct location of parts.

1. Oil the new bushing, and install it on the bushing replacer tool, then install the bushing (Fig. 28). When the tool bottoms against the distribu-

**100% SATISFACTION GUARANTEED**

**BUY IT NOW!**

**Click Here To Order**

PayPal | American Express | Discover | MasterCard | VISA

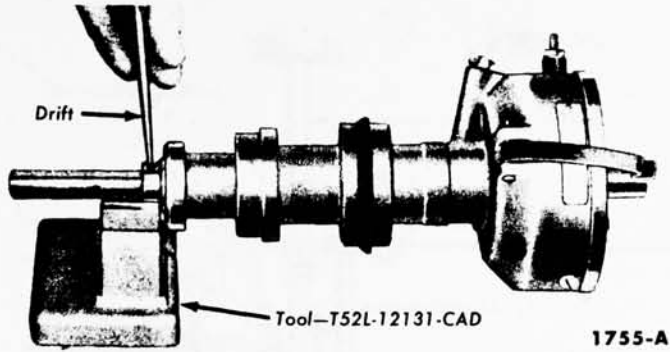

FIG. 24—Shaft Collar Roll Pin Removal or Installation

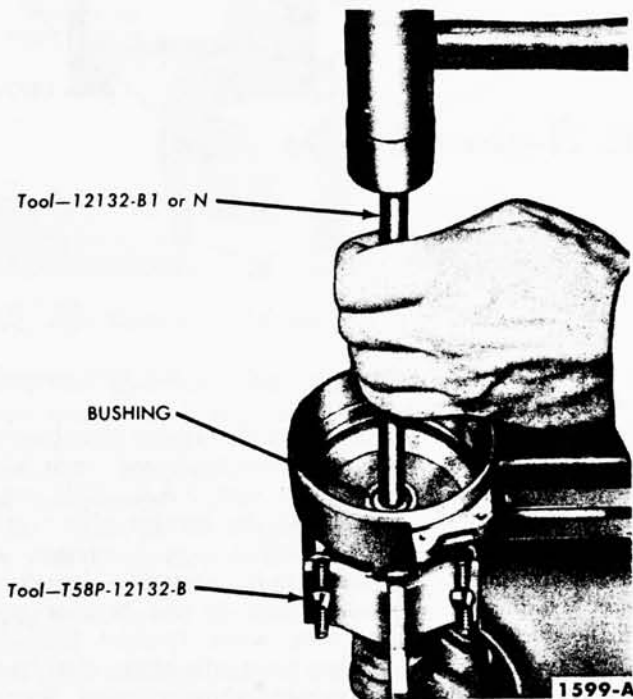

FIG. 26—Bushing Removal

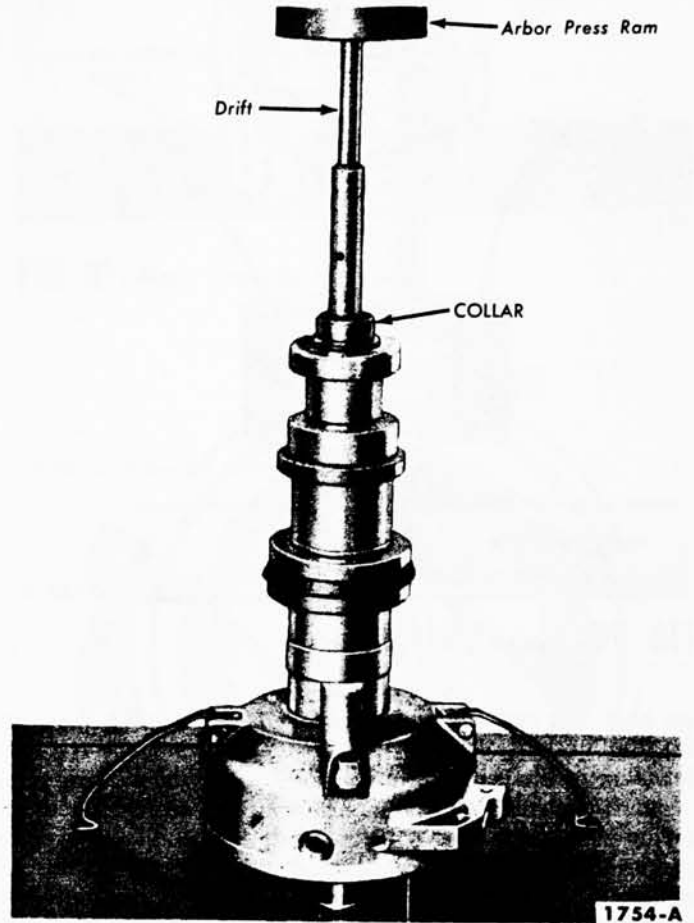
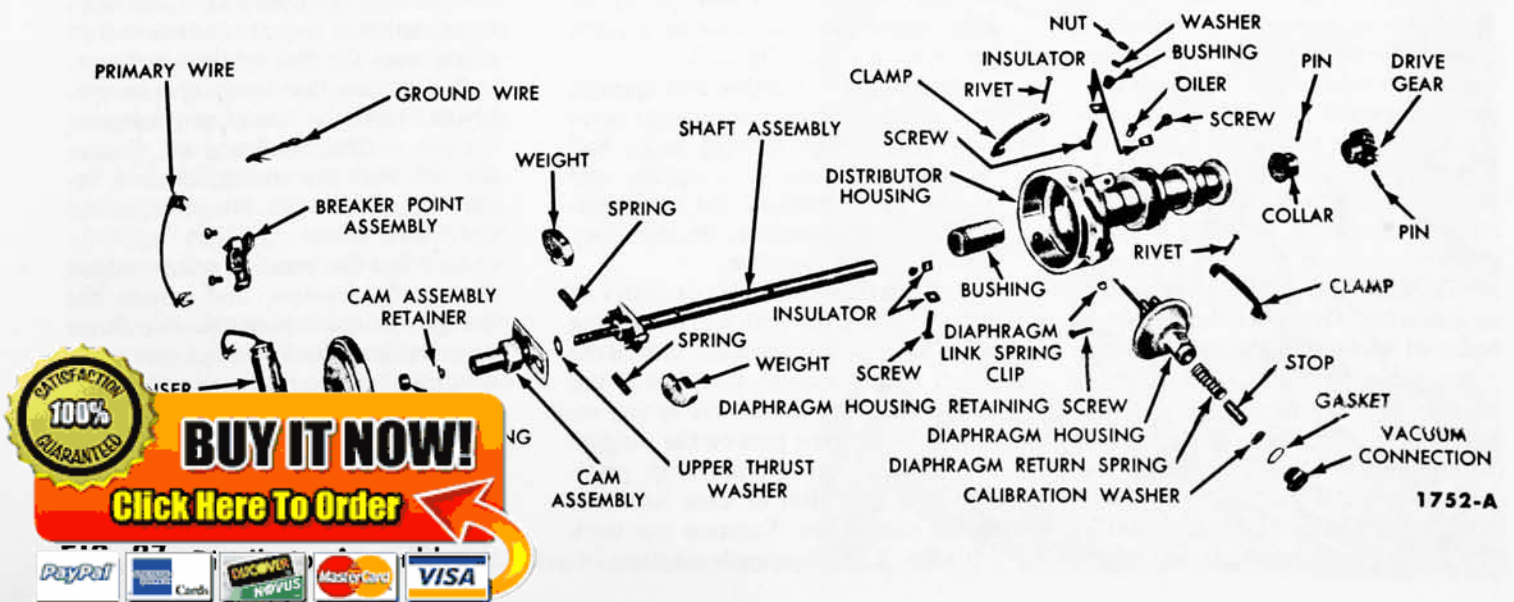

FIG. 25—Shaft Removal



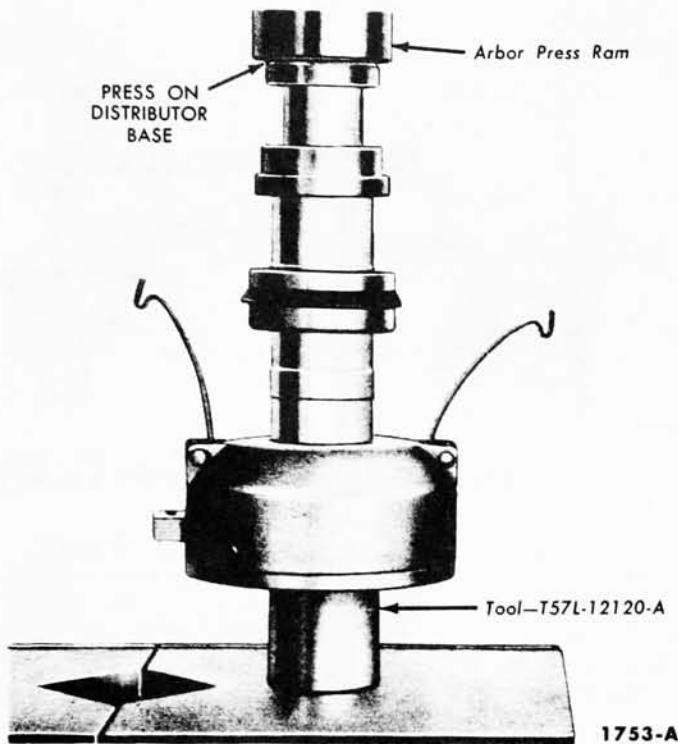

FIG. 28—Bushing Installation

tor base, the bushing will be installed to the correct depth. Burnish the bushing to the proper size (Fig. 29).

2. If the old shaft and gear are being installed, oil the shaft and slide it into the distributor body. Place the collar in position on the shaft and align the holes in the collar and shaft, then install a new pin (Fig. 24). Check the shaft end play with a feeler gauge placed between the centrifugal advance adjusting bracket plate and the top of the bushing. If the end play is not within limits (0.022-0.030 inch), replace the shaft.

Press the gear on the shaft (Fig. 30), using the marks made on the gear and shaft as guides to align the pin holes. Check the gear location dimension. With all end play removed (gear pushed toward the distributor base), this dimension should be 5.111-5.116 inches from the bottom face of the gear to the bottom face of the distributor mounting pad (Fig. 30). Install the retaining pin (Fig. 22)

The shaft and gear are replaced as an assembly. One part should not be replaced without replacing the other.

ugal advance adjusting bracket plate and the top of the bushing. Tighten the backing screw on the tool enough to remove all shaft end play.

Place the collar in position and support the shaft. While holding the collar in position against the distributor housing drill a  $\frac{1}{8}$ -inch hole through the shaft using the access hole in the collar as a pilot. Install the pin (Fig. 24). With the supporting tool and the 0.022-inch feeler gauge still installed, install the drive gear (Fig. 30). Remove the assembly from the press and remove the supporting tool and feeler gauge. Drill a  $\frac{1}{8}$ -inch hole through the gear and shaft, using the hole in the gear shoulder as a pilot. Install a new pin (Fig. 22).

3. Install the weights and springs, then fill the groove in the weight pivot pin with a high melting point ball bearing lubricant. If a spring and bracket were marked for identification upon disassembly, be sure they are assembled together.

4. Lubricate the inside diameter of the cam assembly with a high melting point ball bearing lubricant. Install the upper thrust washer, then install the cam and secure it with the spring retainer. Be sure the pins on the weights are in the slots on the stop plate. Apply a light film of cam lubricant to the cam lobes. Saturate the wick with S.A.E. 10W engine oil, then in-

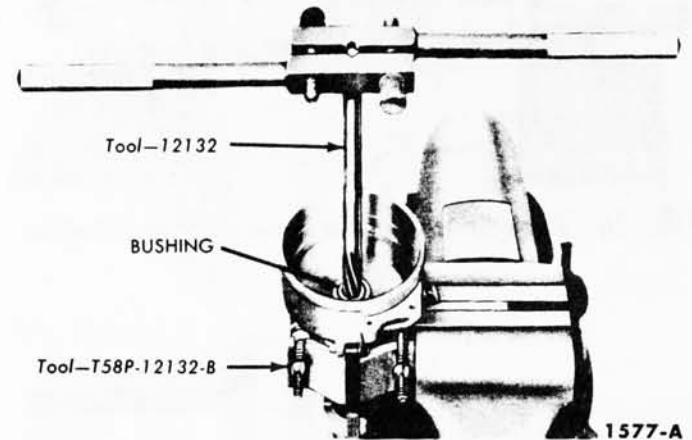

FIG. 29—Burnishing Bushing

stall the wick in the cam assembly (Fig. 32).

5. Clean the breaker plate bearings as previously explained, then lubricate them with S.A.E. 10W engine oil. Install the breaker plate.

6. Install a new condenser and breaker point assembly. Install the ground wire on the breaker point attaching screw furthest from the breaker point adjustment slot. Install the breaker plate retainers. Be sure the ground wire lug is attached to the breaker plate retainer attaching screw. Install the primary wire and the insulator on the terminal screw. Install the bushing and terminal screw in the distributor base, then secure it in place with the flat washer and nut.

7. Position the diaphragm assembly and hook the diaphragm link over the pin on the breaker plate. Secure the link with the spring retainer. Secure the diaphragm assembly to the distributor base.

8. Align the breaker points, adjust the spring tension, and adjust the breaker points. Install the distributor on a test set, check the breaker point dwell and resistance, and adjust the centrifugal and vacuum advance.

#### DISTRIBUTOR INSTALLATION

The distributor installation is shown in Fig. 33.

1. If the crankshaft was rotated

**100% SATISFACTION GUARANTEED**

**BUY IT NOW!**

**Click Here To Order**

PayPal | American Express | Discover | MasterCard | VISA

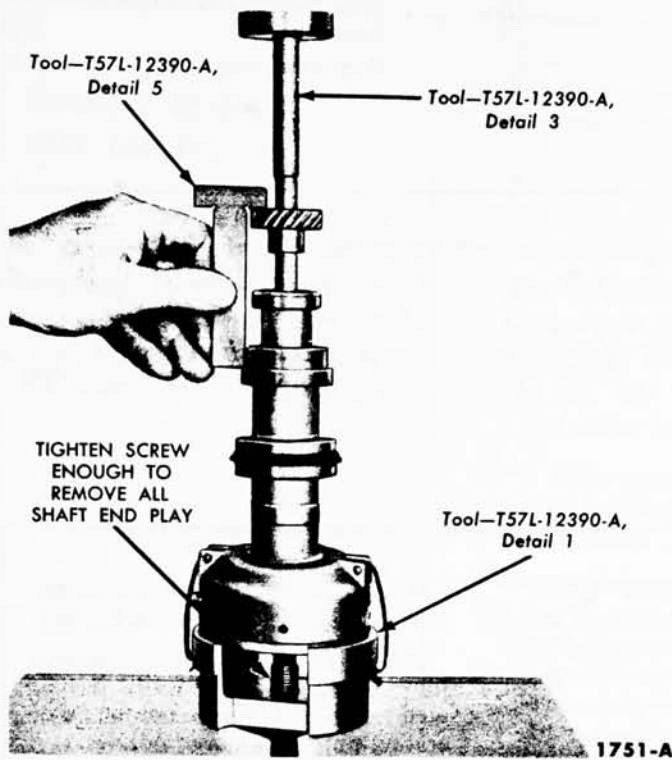

FIG. 30—Gear Installation

while the distributor was removed from the engine, it will be necessary to retime the engine. Turn the engine until No. 1 piston is on T.D.C. after the compression stroke. Align the T.D.C. mark on the crankshaft damper with the timing pointer. Install the distributor with the rotor at the No. 1 firing position and the breaker points open.

If the crankshaft has not been disturbed, install the distributor using the marks previously scribed on the distributor body and engine block as guides.

**Make sure the oil pump intermediate shaft properly engages the distributor shaft. It may be necessary to crank the engine with the starter, after the distributor drive gear is partially engaged, in order to engage the oil pump intermediate shaft.**

2. Install the rotor and the distributor cap. Connect the coil to distributor cap high tension lead, and connect the primary wire at the distributor.

3. Check the ignition timing with timing light and adjust it if necessary. Connect the vacuum line, and

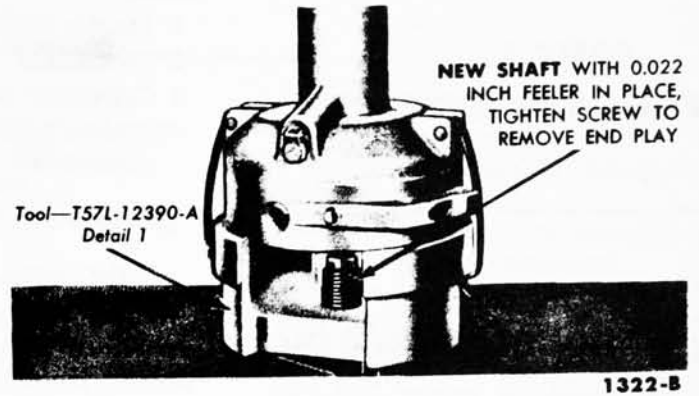

FIG. 31—New Shaft Installation

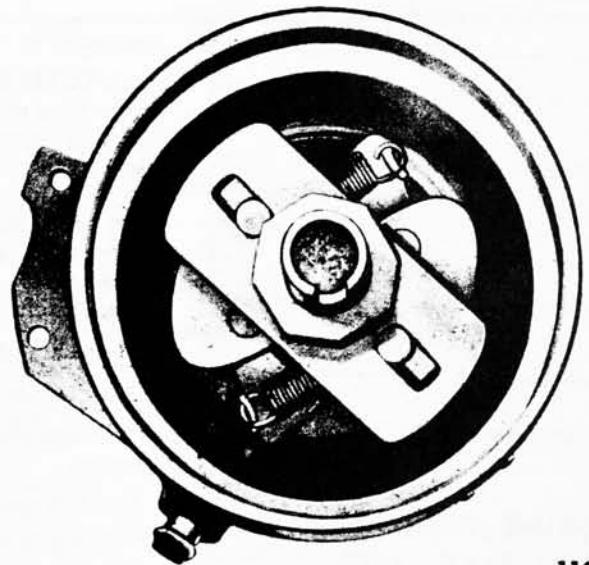

FIG. 32—Weights, Springs, and Cam Installed



**100% SATISFACTION GUARANTEED**

**BUY IT NOW!**

**Click Here To Order**

PayPal   American Express   Discover   MasterCard   VISA

Distributor Installation

**PART 3  
FUEL SYSTEM**



Section	Page	Section	Page
1 Trouble Shooting	1-58	5 Fuel Pumps and Vacuum Booster	1-72
2 Air Cleaner	1-59	6 Fuel Tank and Lines	1-75
3 Carburetor	1-60		
4 Throttle Linkage Adjustments	1-72		

**1 TROUBLE SHOOTING**

*If the cause of engine trouble has been traced to the fuel system (page 1-7), refer to the trouble in Table 1 and check the items listed under the trouble.*

*The causes of the trouble are listed in the order of their probable occurrence; therefore the items should be checked in the order listed.*

**TABLE 1—Fuel System Trouble Shooting**

<p><b>ENGINE CRANKS NORMALLY, BUT WILL NOT START</b></p>	<p><b>AUTOMATIC CHOKE.</b> Check the position of the choke plate. If the engine is warm, the plate should be open. If the plate is not open, the engine will load up due to the excessively rich mixture and will not start. If the engine is cold, the plate should be closed. If the plate is not operating properly, check the following items:</p> <ul style="list-style-type: none"> <li>The choke linkage for binding.</li> <li>The fast idle cam for binding.</li> <li>Thermostatic spring housing adjustment.</li> <li>Fast idle speed screw for proper adjustment and operation.</li> <li>Choke plate valve for proper operation.</li> <li>Choke air heat chamber, air line, and choke housing for air leaks.</li> </ul> <p><b>FUEL SUPPLY AT CARBURETOR.</b> Disconnect the carburetor fuel inlet line at the carburetor. Use a suitable container to catch the fuel. Crank the engine to see if fuel is reaching the carburetor.</p> <p>If fuel is not reaching the carburetor, check:</p> <ul style="list-style-type: none"> <li>The fuel pump.</li> <li>The fuel pump flexible inlet line for a collapsed condition.</li> </ul>	<p>If the fuel is reaching the carburetor, the trouble is in the carburetor.</p> <p>Work the throttle by hand several times. Each time the throttle is actuated fuel should spurt from the accelerating pump discharge nozzles.</p> <p>If fuel is discharged by the accelerating pump, the engine is probably flooded, or there is water in the fuel system, or an engine mechanical item, such as valves is at fault.</p> <p>If fuel is not discharged by the accelerating pump, check:</p> <ul style="list-style-type: none"> <li>The accelerating pump discharge ball check for sticking.</li> <li>The accelerating pump discharge screw and discharge holes for clogged passages.</li> <li>The accelerating pump diaphragm for defects.</li> <li>The accelerating pump inlet ball check for freeness and inlet passages for dirt, corrosion, etc.</li> <li>The fuel inlet system including, the fuel inlet screen, the fuel inlet needle and seat assembly, and the float assembly.</li> </ul> <p>Check for dirt in the carburetor, not allowing fuel to enter or be discharged from the idle system.</p>
 <p><b>BUY IT NOW!</b> Click Here To Order</p> 	<ul style="list-style-type: none"> <li>Idle fuel mixture needles not properly adjusted.</li> <li>Engine idle speed set too low.</li> <li>The choke not operating properly.</li> <li>Choke adjustment setting incorrect.</li> </ul>	<ul style="list-style-type: none"> <li>Fuel inlet system not operating properly.</li> <li>Dirt or water in fuel lines or carburetor.</li> <li>Carburetor icing.</li> <li>Fuel pump defective.</li> </ul>



**BUY IT NOW!**

**Click Here To Order**



PayPal

Discover  
Cards

Discover  
Novus

MasterCard

VISA

LIT...

FORM 7750-58