

1 9 5 7

# FORD TRUCK



## SHOP MANUAL



License #2011747



**BUY IT NOW!**

**Click Here To Order**



• FORD MOTOR COMPANY

Copyright © 2011, Forel Publishing Company, LLC, Woodbridge, Virginia

All Rights Reserved. No part of this book may be used or reproduced in any manner whatsoever without written permission of Forel Publishing Company, LLC. For information write to Forel Publishing Company, LLC, 3999 Peregrine Ridge Ct., Woodbridge, VA 22192

## **1957 Ford Truck Shop Manual**

**EAN: 978-1-60371-066-4**

**ISBN: 1-60371-066-3**

Forel Publishing Company, LLC

3999 Peregrine Ridge Ct.

Woodbridge, VA 22192

Email address: [sales@ForelPublishing.com](mailto:sales@ForelPublishing.com)

Website: <http://www.ForelPublishing.com>



This publication contains material that is reproduced and distributed under a license from Ford Motor Company. No further reproduction or distribution of the Ford Motor Company material is allowed without the express written permission of Ford Motor Company.

---

## **Note from the Publisher**

This product was created from the original Ford Motor Company's publication. Every effort has been made to use the original scanned images, however, due to the condition of the material; some pages have been modified to remove imperfections.

---

## **Disclaimer**

Although every effort was made to ensure the accuracy of this book, no representations or warranties of any kind are made concerning the accuracy, completeness or suitability of the information, either expressed or implied. As a result, the information contained within this book should be used as general information only. The author and Forel Publishing Company, LLC shall have neither liability nor responsibility to any person or entity with respect to any loss or damage caused, or alleged to be caused, directly or indirectly by the information contained in this book. Further, the publisher and author are not engaged in rendering legal or other professional services. If legal, mechanical, electrical, or other expert assistance is required, the professional should be sought.



1957

# FORD TRUCK

## Shop Manual

Copyright 1957  
FORD MOTOR COMPANY  
DEARBORN, MICHIGAN  
All rights reserved



**BUY IT NOW!**

Click Here To Order



## INDEX

ENGINES

IGNITION, FUEL, AND  
COOLING SYSTEMS

CLUTCH AND  
TRANSMISSIONS

REAR AXLES

CHASSIS SUSPENSION  
AND FRAMES

STEERING

BRAKES

GENERATING AND  
STARTING SYSTEMS

LIGHTS, INSTRUMENTS,  
AND ACCESSORIES

BODY MAINTENANCE

DOORS, CABS, AND  
FRONT SHEET METAL

INTERIOR TRIM, SEATS,  
AND WINDOWS

MAINTENANCE, LUBRICATION,  
AND TOOLS

PART

1

2

3

4

5

6

7

8

9

10

11

12

13

DECEMBER, 1956

## FOREWORD

This manual has been prepared to provide information for the proper servicing of 1957 Ford Trucks. Body information on the Ranchero has also been included. Other information for servicing the Ranchero is the same as for the 1957 Ford Car and can be found in the 1957 Ford Car and Thunderbird Shop Manual. Service information on the Fordomatic transmission may be found in the 1956-57 Fordomatic Shop Manual.

The manual is divided into 13 parts as designated on the title page. At the beginning of each part is a title page which lists the chapters and the sections included. The heading on each left-hand or even-numbered page indicates the name of the chapter, and the heading on each right-hand or odd-numbered page indicates the section covered.

The descriptions and specifications contained in this manual were in effect at the time the book was approved for printing. Ford Division of Ford Motor Company reserves the right to discontinue models at any time, or change specifications or design, without notice and without incurring obligation.

SERVICE DEPARTMENT  
**FORD DIVISION**  
FORD MOTOR COMPANY



**Chapter 1** GENERAL ENGINE SERVICE

Section	Page
1. General Engine Trouble Shooting . . . . .	1-2
2. Tune-up . . . . .	1-6
3. Manifolds and Exhaust Gas Control Valve . . . . .	1-8
4. Rocker Arm Assembly, Push Rods, and Cylinder Heads . . . . .	1-9
5. Valve Mechanism . . . . .	1-12
6. Timing Chain, Timing Gears, Camshaft, and Bearings . . . . .	1-17
7. Crankshaft and Main Bearings . . . . .	1-19
8. Flywheel . . . . .	1-23
9. Connecting Rods and Bearings . . . . .	1-23
10. Pistons, Pins, and Rings . . . . .	1-25
11. Cylinder Block . . . . .	1-27
12. Oil Pan and Oil Pump . . . . .	1-29
13. Exhaust System . . . . .	1-30
14. Engine Dimensions, and Clearance and Adjustment Specifications . . . . .	1-30

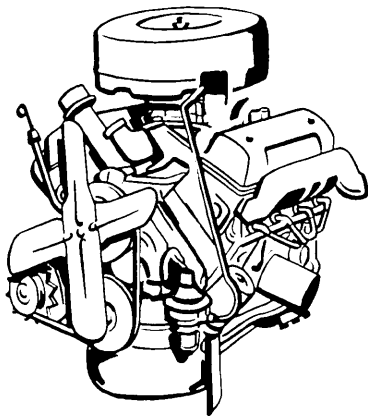

**Chapter 2** 6-CYLINDER ENGINES

Section	Page
1. Description . . . . .	1-37
2. Engine Removal and Installation . . . . .	1-40
3. Engine Supports . . . . .	1-42
4. Manifolds and Exhaust Gas Control Valve . . . . .	1-43
5. Cylinder Head and Valves . . . . .	1-44
6. Crankshaft Damper, Cylinder Front Cover, and Crankshaft Oil Seal . . . . .	1-47
7. Sprockets and Timing Chain, Camshaft, Bearings, and Tappets . . . . .	1-48
8. Flywheel, Crankshaft, and Main Bearings . . . . .	1-50
9. Connecting Rods and Bearings, Pistons, Pins, and Rings . . . . .	1-53
10. Oil Pan, Oil Filter, and Oil Pump . . . . .	1-55
11. Exhaust System . . . . .	1-56
12. General Specifications—6-Cylinder Engines . . . . .	1-57

**Chapter 3** 8-CYLINDER ENGINES

Section	Page
1. Description . . . . .	1-59
2. Engine Removal and Installation . . . . .	1-63
3. Engine Supports . . . . .	1-66
4. Manifolds and Exhaust Gas Control Valve . . . . .	1-67
5. Cylinder Heads and Valves . . . . .	1-68
6. Crankshaft Damper, Cylinder Front Cover, and Crankshaft Oil Seal . . . . .	1-71
7. Sprockets and Timing Chain, Timing Gears, Camshaft, Bearings, and Tappets . . . . .	1-73
8. Flywheel, Crankshaft, and Main Bearings . . . . .	1-78
9. Connecting Rods and Bearings, Pistons, Pins, and Rings . . . . .	1-81
10. Oil Pan, Oil Filter, and Oil Pump . . . . .	1-83
11. Exhaust System . . . . .	1-84
12. General Specifications—8-Cylinder Engines . . . . .	1-85

# Part 1—ENGINES

## Chapter 1

### GENERAL ENGINE SERVICE

Section	Page
1 General Engine Trouble Shooting .....	1-2
2 Tune-Up .....	1-6
3 Manifolds and Exhaust Gas Control Valve .....	1-8
4 Rocker Arm Assembly, Push Rods, and Cylinder Heads .....	1-9
5 Valve Mechanism .....	1-12
6 Timing Chain, Timing Gears, Camshaft, and Bearings .....	1-17
7 Crankshaft and Main Bearings .....	1-19
8 Flywheel .....	1-23
9 Connecting Rods and Bearings .....	1-23
10 Pistons, Pins, and Rings .....	1-25
11 Cylinder Block .....	1-27
12 Oil Pan and Oil Pump .....	1-29
13 Exhaust System .....	1-30
14 Engine Dimensions, and Clearance and Adjustment Specifications .....	1-30

The service procedures contained in this chapter apply to all engines. The cleaning, inspection, repair, and overhaul procedures of the component engine parts apply after the parts have been removed from the engine, or in the case of a complete engine overhaul, after the engine has been disassembled.

To completely disassemble or assemble an engine, follow all the removal or installation procedures in the applicable engine chapter. To remove or install an individual part, refer to the section covering the part in the applicable engine chapter.

## 1. GENERAL ENGINE TROUBLE SHOOTING

Poor engine performance can be caused by the need for a general engine tune-up, by gradual wear of engine parts, or by a sudden parts failure. Good diagnosis will indicate the need of a complete engine tune-up, individual adjustments, part(s) replacement or overhaul, or the need of a complete engine overhaul.

The five major steps in restoring good engine performance are:

1. **ESTABLISH THE TROUBLE.** Make sure that the trouble as stated by the owner actually exists. Determine, if possible, if any work has been performed recently which could be the cause of the present trouble.

2. **ISOLATE THE CAUSE IN THE PROPER SYSTEM.** Trace the cause of the trouble to the point where it has been isolated in one of the following systems: *ignition, fuel, engine, cooling, or exhaust.*

**LOCATE THE CAUSE IN THE SYSTEM.**

Engine performance complaints usually fall under one of the following basic headings: *engine will not crank; engine cranks normally, but will not start; engine starts, but fails to keep running; engine runs, but misses; rough engine idle; poor acceleration; engine does not develop full power, or has poor high speed performance; excessive fuel consumption; engine overheats; or the engine fails to reach normal operating temperature.*

Table 1 is a general trouble shooting chart which lists basic engine troubles with procedures and checks to be performed to help isolate the cause of the trouble in a particular system. The reference after each check refers to that part of the manual which covers checking procedures as well as corrections to be made in the various systems. When a particular trouble can not be traced to a definite system by a simple check, the possible systems that could be at fault are listed in the order of their probable occurrence; therefore, in most cases, the checks should be made in the order listed. Some consideration, however, should be given to logical order. For example, if the spark plugs are removed for testing

g that the trouble  
ck as a final check



and they are not the cause of the trouble, and several checks later calls for a compression test, to save time, check the compression while the spark plugs are out.

A separate trouble shooting chart is included in the ignition, fuel, and cooling system chapters. These charts list the basic troubles listed in Table 1, but cover only the items relating to the particular system under con-

sideration. For example, in Table 1 under Poor Acceleration, the ignition system is listed as a probable cause of the trouble. In the Ignition System Trouble Shooting Chart under Poor Acceleration, all the ignition system items that affect acceleration are listed. These items should all be checked before proceeding to the next probable system listed in Table 1.

**Table 1—General Engine Trouble Shooting**

#### **Engine Will Not Crank**

The cause of this trouble is usually in the starting system (Part 8—Chapter 2).

If the starting system is not at fault, check for a hydrostatic lock or a seized engine. Remove the spark plugs, then attempt to crank the engine with the starter. If the engine cranks, it indicates that water is leaking into the cylinders. Remove the cylinder head (s) and inspect gasket and/or head for cracks. Also examine the cylinder block for cracks.

#### **Engine Cranks Normally, But Will Not Start**

Check the fuel supply.

If there is sufficient fuel in the tank, the cause of the trouble probably lies in either the ignition or the fuel system.

To isolate the cause:

Remove the ignition wire from a spark plug, and insert a piece of proper sized metal rod in the insulator so that it protrudes from the insulator. With the ignition on and the starter cranking the engine, hold the end of the rod approximately  $\frac{3}{16}$  inch from the cylinder block.

If there is no spark or a weak spark, the cause of the trouble is in the ignition system (Part 2—Chapter 1).

If the spark is good, check the spark plugs (Part 2—Chapter 1).

If the spark plugs are not at fault, check the fuel system (Part 2—Chapter 2).

If the fuel system is not at fault, check the valve timing (page 1-16).

#### **Engine Starts, But Fails To Keep Running**

If the engine starts and runs for a few seconds, then stops, check the:

Fuel system (Part 2—Chapter 2).

Ignition system (Part 2—Chapter 1).

#### **Engine Runs, But Misses**

First, determine if the miss is steady or erratic and at what speed the miss occurs by running the engine at various speeds under load.

**MISSES STEADILY AT ALL SPEEDS.** Isolate the miss by running the engine with one cylinder not firing. This is done by running the engine with the ignition wire removed from one spark plug at a time, until all cylinders have been checked. Ground the spark plug wire removed.

If the engine speed changes when a particular cylinder is shorted out, that cylinder was delivering power before being shorted out. If no change in the engine operation is evident, the miss was caused by that cylinder not delivering power before being shorted out, check the:

Ignition system (Part 2—Chapter 1).

Engine compression to determine which mechanical component of the engine is at fault (page 1-7).

**MISSES ERRATICALLY AT ALL SPEEDS.** If the miss cannot be isolated in a particular cylinder, check the:

Exhaust gas control valve (page 1-9).

Ignition system (Part 2—Chapter 1).

Fuel system (Part 2—Chapter 2).

Engine compression to determine which mechanical component of the engine is at fault (page 1-7).

Valve timing (page 1-30).



**BUY IT NOW!**

**Click Here To Order**



Table 1—General Engine Trouble Shooting (cont'd)

**Engine Runs, But Misses (cont'd)****MISSES ERRATICALLY AT ALL SPEEDS (cont'd)**

Cooling system for internal leaks and/or for a condition that prevents the engine from reaching normal operating temperature (Part 2—Chapter 3).

**MISSES AT IDLE ONLY. Check the:**

- Fuel system (Part 2—Chapter 2).
- Ignition system (Part 2—Chapter 1).
- Valve lash adjustment (page 1-15).
- Engine compression for low compression (page 1-7).

**MISSES AT HIGH SPEED ONLY. Check the:**

- Ignition system (Part 2—Chapter 1).
- Fuel system (Part 2—Chapter 2).
- Cooling system for overheating or internal leakage (Part 2—Chapter 3).

**Rough Engine Idle**

- Valve lash (page 1-15).
- Exhaust gas control valve (page 1-9).
- Intake manifold leakage.
- Ignition system (Part 2—Chapter 1).
- Leaking power brake vacuum booster (Part 7—Chapter 2).
- Fuel system (Part 2—Chapter 2).
- Loose engine mounts (Part 1—Chapter 2 or 3).
- Improper cylinder head bolt torque.
- Camshaft lobe lift (page 1-19).

**Poor Acceleration**

- Ignition system (Part 2—Chapter 1).
- Fuel system (Part 2—Chapter 2).
- Exhaust gas control valve (page 1-9).
- Valve lash adjustment (page 1-15).
- Dragging brakes (Part 7).
- Slipping clutch (Conventional and Overdrive Transmission) (Part 3—Chapter 1).
- Improper adjustment of the Fordomatic transmission.

**Engine Does Not Develop Full Power, Or Has Poor High Speed Performance**

Determine if the trouble exists when the engine is cold, at normal operating temperature, or at all engine temperatures.

**ENGINE COLD**

- Exhaust gas control valve (page 1-9).
- Fuel system (Part 2—Chapter 2).
- Cooling system if the engine reaches operating temperature slowly (Part 2—Chapter 3).

**ENGINE AT NORMAL OPERATING TEMPERATURE**

- Exhaust gas control valve (page 1-9).
- Fuel system (Part 2—Chapter 2).

**ALL ENGINE TEMPERATURES**

- Engine compression (page 1-7).
- Ignition system (Part 2—Chapter 1).
- Fuel system (Part 2—Chapter 2).
- Cooling system (Part 2—Chapter 1).



**BUY IT NOW!**

**Click Here To Order**



Table 1—General Engine Trouble Shooting (cont'd)

**Engine Does Not Develop Full Power, Or Has Poor High Speed Performance (cont'd)****ALL ENGINE TEMPERATURES (cont'd)**

- Valve lash adjustment (page 1-15).
- Camshaft lobe lift (page 1-19).
- Valve timing (page 1-16).
- Cooling system if the engine overheats (Part 2—Chapter 3).
- Excessive back pressure in the exhaust system.
- Torque converter stall speed (Fordomatic).
- Torque converter fails to lock up at high speeds (Fordomatic).
- Brake adjustment (Part 7).
- Tire pressure (Part 5—Chapter 3).
- Excessive carbon in engine.

**Excessive Fuel Consumption**

Determine the actual fuel consumption with test equipment installed in the truck.

If the test indicates that the fuel consumption is not excessive, demonstrate to the owner how improper driving habits will affect fuel consumption.

If the test indicates that the fuel consumption is excessive, make the preliminary checks listed below before proceeding to the fuel and ignition systems.

**PRELIMINARY CHECKS**

- Tires (Part 5—Chapter 3).
- Wheel alignment (Part 5—Chapter 1).
- Brakes (Part 7).
- Exhaust gas control valve (page 1-9).
- Odometer calibration (Part 9—Chapter 1).
- Ignition timing (Part 2—Chapter 1).
- Valve lash (page 1-15).

**FUEL SYSTEM** (Part 2—Chapter 2).

**IGNITION SYSTEM** (Part 2—Chapter 1).

**ENGINE COMPRESSION** (page 1-7).

**COOLING SYSTEM** (Part 2—Chapter 3).

**TORQUE CONVERTER STALL SPEED** (Fordomatic).

**TORQUE CONVERTER CONTINUES TO CONVERT AT LOCKUP SPEED** (Fordomatic).

**Engine Overheats**

- Temperature sending unit (Part 9—Chapter 1).
- Temperature gauge (Part 9—Chapter 1).
- Cylinder head bolt torque (Part 1—Chapter 2 or 3).
- Cooling system (Part 2—Chapter 3).
- Ignition timing (Part 2—Chapter 1).
- Valve timing (page 1-16).
- Valves (page 1-12).
- Exhaust system (page 1-30).
- Brake adjustment (Part 7).

**Operating Temperature**

- Part 9—Chapter 1).
- Chapter 1).
- apter 3).



**BUY IT NOW!**

**Click Here To Order**



## 2. TUNE-UP

The Tune-up Schedule (Table 2) is applicable for either a minor or major tune-up as governed by the condition of the engine. The reference after each operation

refers to that part of the manual which describes the procedure to be followed. Perform the operations in the sequence listed.

Table 2—Tune-Up Schedule

Operation	Perform on		Recommended Procedure
	Minor	Major	
<b>BATTERY AND CABLES</b> Clean cables, connectors, and terminals.		x	Part 8 Chapter 1
Inspect cables for worn insulation.		x	
Inspect battery for cracks and leaks.		x	
Check battery state of charge.	x	x	
Grease battery cables.		x	
<b>GENERATOR</b> Check generator output.		x	Part 8 Chapter 1
<b>REGULATOR</b> Visually inspect wiring.	x	x	Part 8 Chapter 1
Check current and voltage.		x	
<b>ENGINE COMPRESSION</b> Take compression reading of each cylinder.		x	Page 1-7
<b>SPARK PLUGS</b> Clean, adjust, and test.	x	x	Part 2 Chapter 1
<b>INTAKE MANIFOLD</b> Check and adjust manifold bolt torque.		x	Part 1 Chapter 2 or 3
<b>VALVE LASH</b> Check and adjust intake and exhaust valve lash.	x	x	Page 1-15
<b>DISTRIBUTOR</b> Check and adjust breaker arm spring tension.		x	Part 2 Chapter 1
Check condition of contact points.	x	x	
Check and adjust point dwell.	x	x	
Check and adjust vacuum advance.		x	
Check and adjust centrifugal advance (Centrifugal Advance Distributor).		x	
Test distributor circuit and point resistance.		x	
		x	
	x		Part 2 Chapter 1

Operation	Perform on		Recommended Procedure
	Minor	Major	
<b>CONDENSER</b> Check for leakage, series resistance, and capacity.		x	Part 2 Chapter 1
<b>COIL AND RESISTOR</b> Check coil output.		x	Part 2 Chapter 1
Check the voltage drop at the resistor.		x	
<b>TIMING</b> Check and adjust ignition timing.	x	x	Part 2 Chapter 1
<b>VACUUM</b> Check manifold vacuum.	x	x	Page 1-7
<b>FUEL PUMP</b> Clean fuel pump bowl on the mechanical pump, or the bottom cover and filter screen on the electric pump.	x	x	Part 2 Chapter 2
Test fuel pump pressure.		x	
Test fuel pump capacity.		x	
<b>CARBURETOR</b> Clean carburetor air cleaner filter.	x	x	Part 2 Chapter 2
Clean carburetor fuel bowl.		x	
Adjust float setting.		x	
Check fuel level.		x	
Adjust engine idle speed.	x	x	
Adjust idle fuel mixture.	x	x	
<b>FUEL FILTER</b> Clean fuel filter.		x	Part 2 Chapter 2
<b>EXHAUST ANALYSIS</b> Perform an exhaust gas analysis.		x	Page 1-8
<b>IGNITION SYSTEM RESISTANCE TEST</b> Perform a primary circuit and secondary circuit resistance test.		x	Part 2 Chapter 1
<b>COOLING SYSTEM</b> Check and adjust the tension of the drive belts.	x	x	Part 2 Chapter 3
Check condition of hoses and radiator cap.	x	x	

**100% SATISFACTION GUARANTEED**

**BUY IT NOW!**

**Click Here To Order**

PayPal American Express Discover MasterCard VISA

### Manifold Vacuum Test

A test of manifold vacuum is a valuable aid in determining the condition of an engine and also in helping to locate the cause of poor engine performance. To test manifold vacuum:

1. Operate the engine for a minimum of ½-hour at 1200 rpm.
2. Install an accurate, sensitive vacuum gauge on the fuel pump end of the vacuum line or on the fitting in the intake manifold.
3. Run the engine at recommended idle rpm.
4. Check the vacuum reading on the gauge.

**TEST CONCLUSIONS.** Manifold vacuum is affected by carburetor adjustment, valve timing, the condition of the valves, valve lash, cylinder compression, and gasket leakage at the intake manifold, carburetor, or cylinder head(s).

Because abnormal gauge readings may indicate that more than one of the above factors are at fault, exercise caution in analyzing an abnormal reading. For example, if the vacuum is low, the correction of one item may increase the vacuum enough to indicate that the trouble has been corrected. It is important, therefore, that each cause of an abnormal reading be investigated and further tests conducted where necessary in order to arrive at the correct diagnosis of the trouble.

Table 3 lists various types of readings and their possible causes.

Allowance should be made for the effect of altitude on the gauge reading. The engine vacuum will decrease with an increase in altitude.

### Engine Compression Test

1. Be sure the battery is good. Operate the engine for a minimum of ½ hour at 1200 rpm. Turn the ignition switch off, then remove all the spark plugs.

2. Set the throttle plates (primary throttle plates only on the 4-barrel carburetor) and choke plate in the wide open position.

3. Install a compression gauge in No. 1 cylinder.

4. Crank the engine until the gauge registers a maximum reading and record the reading. Note the number of compression strokes required to obtain the maximum reading.

5. Repeat the test on each cylinder, cranking the engine the same number of strokes for each cylinder as was required to obtain a maximum reading on No. 1 cylinder.

**TEST CONCLUSIONS.** A variation of ± 10 pounds from specified pressure is satisfactory. However, the compression of all cylinders should be uniform within 10 pounds.

A reading of more than 10 pounds above normal indicates excessive deposits in the cylinder.

A reading of more than 10 pounds below normal indicates leakage at the head gasket, rings, or valves.

A low even compression in two adjacent cylinders indicates a head gasket leak. This should be checked before condemning the rings or valves.

To determine whether the rings or the valves are at fault, squirt the equivalent of a tablespoon of heavy oil in the combustion chamber, then crank the engine to distribute the oil and repeat the compression test. The

Table 3—Manifold Vacuum Gauge Readings

Gauge Reading	Engine Condition
18-19 inches (223, 302 and 332 cubic inch engines). 19-20 inches (272 cubic inch engines)	Normal
Low and steady	Loss of power in all cylinders possibly caused by late ignition or valve timing, or loss of compression due to leakage around the piston rings.
Very low	Intake manifold, carburetor, or cylinder head gasket leakage.
Needle fluctuates steadily as speed increases.	A partial or complete loss of power in one or more cylinders caused by a leaking valve, leaking head or manifold gasket, a defect in the ignition system, or a weak valve spring.
Gradual drop in reading at engine idle.	Restriction in the exhaust system.
Intermittent fluctuation	An occasional loss of power possibly caused by a defect in the ignition system or a sticking valve.
Intermittent fluctuation needle.	Improper idle mixture adjustment, carburetor or manifold gasket leak, or possibly late valve timing.

**100% SATISFACTION GUARANTEED**

**BUY IT NOW!**

**Click Here To Order**

PayPal American Express Discover MasterCard VISA

oil will temporarily seal leakage past the rings. If approximately the same reading is obtained, the rings are satisfactory, but the valves are leaking. If the compression has increased 10 pounds or more over the original reading, there is leakage past the rings.

During a compression test, if the pressure fails to climb steadily and remains the same during the first two successive strokes, but climbs higher on the succeeding strokes, or fails to climb during the entire test, it indicates a sticking valve.

### 3. MANIFOLDS AND EXHAUST GAS CONTROL VALVE

Hot exhaust gases are diverted into the intake manifold heat riser to provide the heat necessary to vaporize the incoming fuel-air mixture and to minimize engine stalling and carburetor icing during cold engine operation.

On the 223 cubic inch engines, a chamber (heat riser) is cast into the intake manifold center section between the carburetor and exhaust manifold mounting flanges. A thermostatically controlled valve, located in the exhaust manifold, directs the exhaust gases into this area.

All 8-cylinder intake manifolds contain a passage through the center section and under the carburetor, through which the hot exhaust gases are directed.

On the ECW-Y 272 cubic inch engines, the exhaust gases are diverted into the intake manifold by a thermostatically controlled exhaust valve. The valve is located between the cross-over pipe and the inlet of the

### Exhaust Gas Analysis

An exhaust gas analysis is a method of testing the ratio of fuel and air entering the cylinders, and the adjustment and performance of the carburetor. **However, it cannot be used to calibrate a carburetor.**

As there are various types of analyzers, follow the instructions of the manufacturer. On a dual exhaust system, install the analyzer in the outlet pipe opposite the side of the system that contains the exhaust gas control valve. For example, if the valve is on the right side, install the analyzer in the left muffler outlet pipe.

right exhaust manifold. When the valve is closed (heat on), part of the exhaust gases are diverted from the left exhaust manifold, through the heat riser passage, to the right exhaust manifold. When the valve opens (heat off), more of the exhaust gases from the left manifold are permitted to flow directly out the exhaust system in the normal manner.

An exhaust gas control valve is not used on the heavy duty engines (ECR 272, 302, or 332 cubic inch engines).

### Manifolds

Clean the manifolds in a suitable solvent, then dry them with compressed air. Scrape all carbon deposits from the center exhaust passage below the carburetor heat riser of the intake manifold. This carbon acts as an insulator restricting the heating action of the hot exhaust gases.

Inspect the manifolds for cracks or other defects that would make them unfit for further service. Replace all studs that are stripped or otherwise damaged.

**Remove all filings and foreign matter that may have entered the manifolds as a result of repairs.**

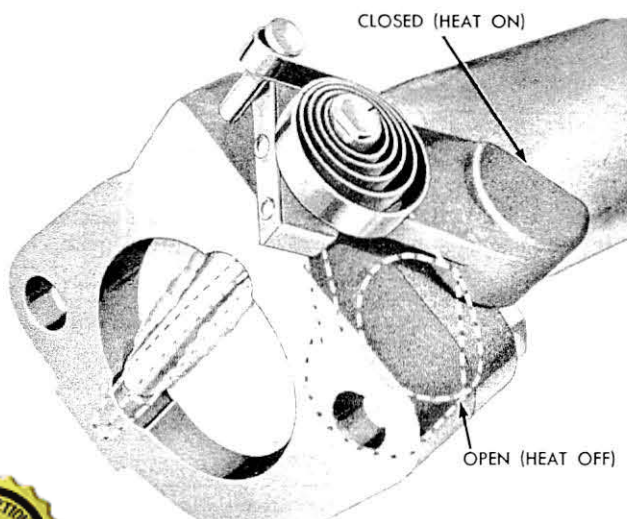

1001-A

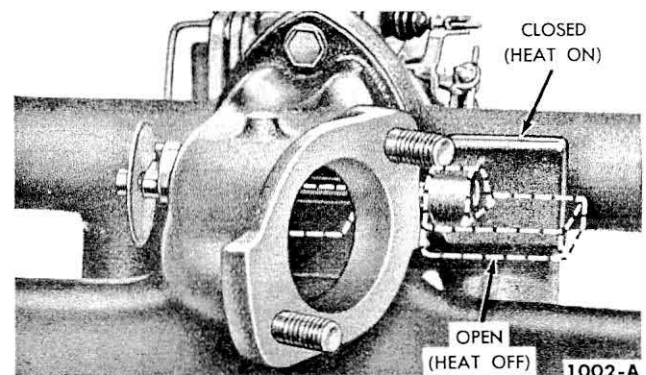

1002-A

Fig. 2—Exhaust Gas Control Valve—223 Cubic Inch Engines

**100% SATISFACTION GUARANTEED**

**BUY IT NOW!**

**Click Here To Order**

Price—ECY-W 272 \$15

PayPal American Express Cards Discover NOVUS MasterCard VISA

## Exhaust Gas Control Valve—223 and ECW-Y 272 Cubic Inch Engines

Check the thermostatic spring (Figs. 1 or 2) to make sure it is hooked on the stop pin. The spring stop is at the top of the valve housing when the valve is properly installed.

Check to make sure the spring holds the valve closed when the engine is cold. Actuate the counterweight by hand to make sure it moves freely through approximately 90° of rotation without binding.

## 4. ROCKER ARM ASSEMBLY, PUSH RODS, AND CYLINDER HEADS

### Rocker Arm Assembly

Clean all the parts thoroughly. Make sure that all oil passages are open.

Check the clearance between each rocker arm and the shaft by checking the I. D. of the rocker arm bore and the O. D. of the shaft. If the clearance between any rocker arm and the shaft approaches 0.006 inch (wear limit), replace the shaft and/or the rocker arm. Inspect the shaft and the rocker arm bore for nicks, scratches, scores, or scuffs. Dress up minor surface defects with a hone.

Inspect the pad at the valve end of the rocker arms for a grooved radius. If the pad is grooved, replace the rocker arm. *Do not attempt to true this surface by grinding.*

Check the rocker adjusting screws and the push rod end of the rocker arms for stripped or broken threads, and the ball end of the adjusting screw for nicks, scratches, or excessive wear.

Check for broken locating springs and inspect the oil drain tube for cracks, sharp bends, or restrictions.

### Push Rods

Check the ball end and the socket end of the push rods for nicks, grooves, roughness, or excessive wear.

The push rods can be visually checked for straightness while they are installed in the engine by rotating them with the valve closed. They also can be checked

The valve is closed when the engine is at normal operating temperature and running at idle speed. However, a properly operating valve will open when very light finger pressure is applied to the counterweight. Rapidly accelerate the engine to make sure the valve momentarily opens. The valve is designed to open when the engine is at normal operating temperature and is operated at high rpm. Free a stuck valve with a penetrating oil or graphite mixture or replace the assembly if necessary.

between ball and cup centers with a dial indicator (Fig. 3). If the runout exceeds 0.020 inch at any point, discard the rod. *Do not attempt to straighten push rods.*

### Cylinder Heads

To protect the machined surfaces of the cylinder head, do not remove the holding fixtures while the head is off the engine.

**CLEANING AND INSPECTION.** With the valves installed to protect the valve seats, remove carbon deposits from the combustion chambers and valve heads with a scraper and a wire brush. *Be careful not to scratch the cylinder head gasket surface.* After the valves are removed, clean the valve guide bores with a valve guide cleaning tool. Use cleaning solvent to remove old gasket sealer, dirt, and grease.

Check the head for cracks, and the gasket surface for burrs and nicks. Replace the head if it is cracked. *Do not plane or grind more than 0.010 inch from the cylinder head gasket surface.* Remove all burrs or scratches with an oil stone.

Check the exhaust valve seat insert for signs of excessive wear, cracks, or looseness (ECR 272, 302, and 332 cubic inch engines).

**Cylinder Head Flatness.** Check the flatness of the cylinder head gasket surface (Fig. 4). Specifications for

Dial indicator

1003-A

Typical

**BUY IT NOW!**

Click Here To Order

PayPal American Express Discover MasterCard VISA

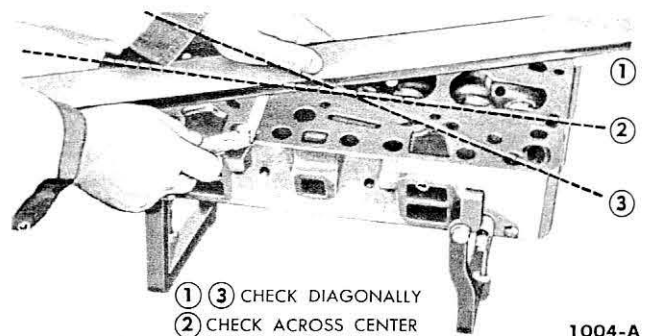

Fig. 4—Cylinder Head Flatness—Typical

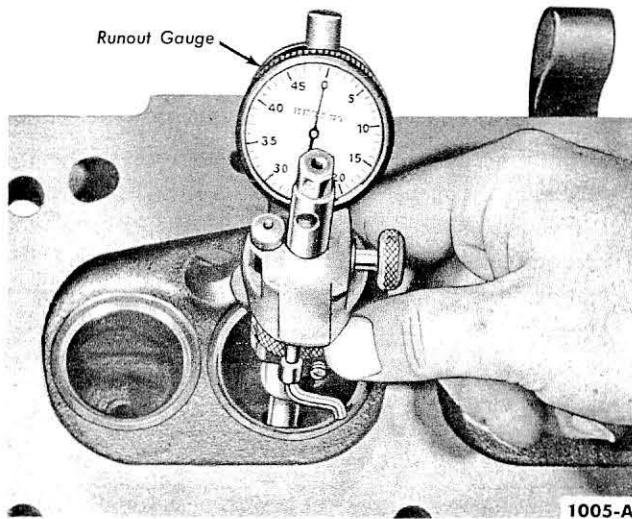

Fig. 5—Valve Seat Runout—Typical

flatness are 0.006 inch maximum over all, or 0.003 inch in any 6 inches.

**Valve Seat Runout.** Check the valve seat runout with an accurate gauge (Fig. 5). Follow the instructions of the gauge manufacturer. The total runout should not exceed 0.0025 inch (wear limit).

**Valve Seat Width.** Measure the valve seat width (Fig. 6). Refer to the specification section for the correct limits.

**REAMING VALVE GUIDES.** If it becomes necessary to ream a valve guide (Fig. 7) to install a valve with an oversize stem, a reaming kit is available which contains a 0.003-inch O.S. reamer with a standard diameter pilot, a 0.015-inch O.S. reamer with a 0.003-inch O.S. pilot, and a 0.030-inch reamer with a 0.015-inch O.S. pilot.

When going from a standard size valve to an oversize valve, always use the reamers in sequence. *Always reface the valve seat after the valve guide is reamed.*

**REFACING VALVE SEATS.** Refacing of the valve



—Typical

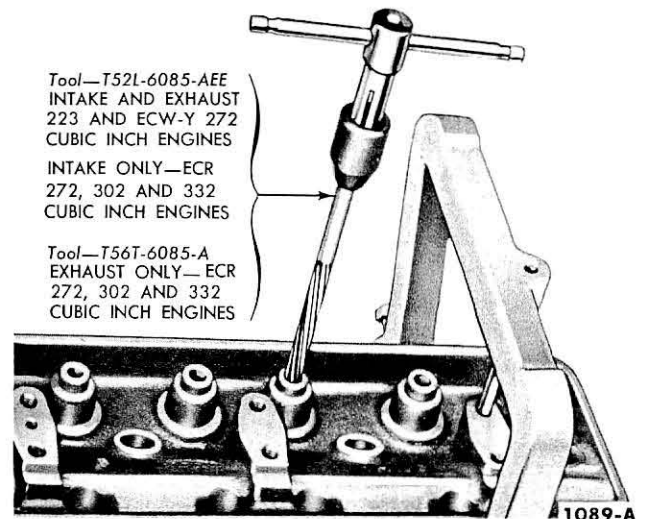

Fig. 7—Reaming Valve Guides—Typical

seats should be closely coordinated with the refacing of the valve face so the finished seat will match the valve face and be centered. This is important so that the valve and seat will have a good compression and vacuum tight fit. Be sure that the refacer grinding wheels are properly dressed.

Grind the valve seat to a true 45° angle (Fig. 8). Remove only enough stock to clean up pits, grooves, or to correct the valve seat runout. After the seat is ground, measure the seat width (Fig. 6). Narrow the seat, if necessary to bring it within limits.

If the valve seat width exceeds the maximum limit, remove enough stock from the top edge and/or bottom edge of the seat to reduce the width to specifications (Fig. 8). Use a 30° angle grinding wheel to remove stock from the bottom of the seat (raise the seat). Use a 60° angle wheel to remove stock from the top of the seat (lower the seat).

The finished valve seat should contact the approxi-

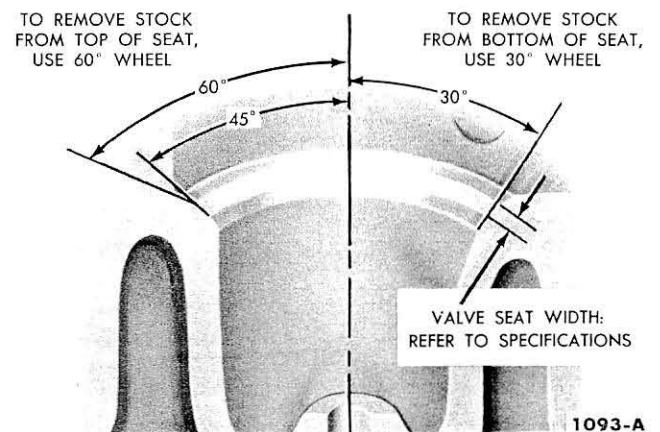

Fig. 8—Valve Seat Refacing—Typical

**100% SATISFACTION GUARANTEED**

**BUY IT NOW!**

**Click Here To Order**

PayPal   American Express   DISCOVER   MasterCard   VISA

mate center of the valve face. To determine where the valve seat contacts the face, coat the seat with Prussian blue, then set the valve in place. Rotate the valve with light pressure. If the blue is transferred to the center of the valve face, the contact is satisfactory. If the blue is transferred to the top edge of the valve face, lower the valve seat. If the blue is transferred to the bottom edge of the valve face, raise the valve seat.

After refacing the valve seat, it is good practice to lightly lap in the valve with a medium grade lapping compound. Remove all the compound from the valve and seat after the lapping operation.

**EXHAUST VALVE SEAT INSERT REPLACEMENT—ECR 272, 302, AND 332 CUBIC INCH ENGINES.** To remove the valve seat insert, invert the head and position a drift in the exhaust valve port, then drive the insert out.

Counterbore the insert recess to specifications (Fig. 9). Cut slightly below the old counterbore depth to clean up this face (approximately 0.001-0.002 inch). Clean out chips and oil from the recess.

Chill the oversize insert and the installation tool in dry ice for 1/2 hour. *The insert must be installed immediately upon removal from the dry ice. Protect the hands when handling the chilled insert and tool.* Position the insert on the tool with the small radius on the outer edge facing outward. Pilot the driving tool in the valve guide, then drive the insert into the counterbore until it is fully seated. Do notpeen the area around the insert. Reface the new insert.

**WATER OUTLET CONNECTION — 8-CYLINDER ENGINES.** The cylinder heads on each particular engine are interchangeable.

To change the heads from one bank to another on a 272 cubic inch engine, it is necessary that a plug be installed in the water outlet at the rear of the right head and a water temperature sending unit adapter is installed in the water opening at the rear of the left head.

To change the heads from one bank to another on a 302 or 332 cubic inch engine, it is necessary to remove

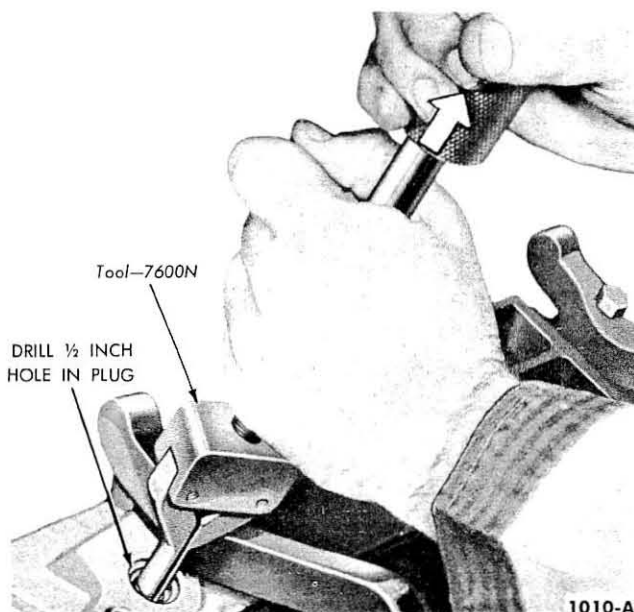

Fig. 10—Water Outlet Plug Removal—Typical

the water outlet core plug from the rear of the head, and install a new plug in the water inlet opening at the front end, thereby reversing the water inlet connection, and permitting the head to be installed on the opposite bank.

The temperature sending unit is installed in a threaded boss located in the intake manifold of the 302 and 332 cubic inch engines.

Replacement cylinder heads do not have either the plug or adapter installed; therefore, they can be readily adapted for either right or left installations.

**Water Outlet Plug.** To remove the plug, drill a 1/2-inch hole in the center of the plug and remove it as shown in Fig. 10.

Clean the plug recess thoroughly. Coat the flange of the plug with water resistant sealer and install it with

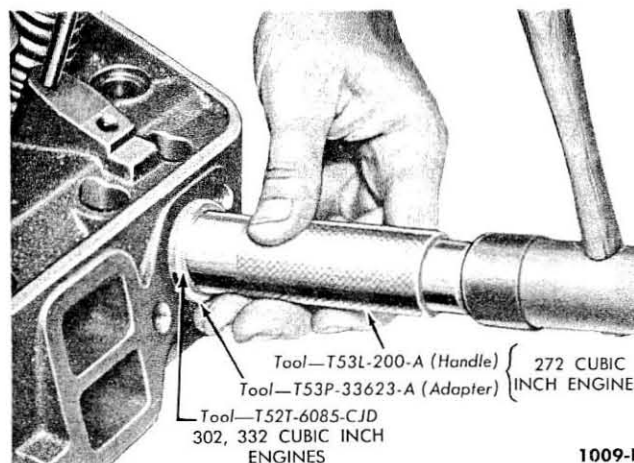

Fig. 11—Water Outlet Plug Installation—Typical

COUNTERBORE TO ENGINE SPECIFICATIONS

EXHAUST VALVE PORT

1210-A

100% SATISFACTION GUARANTEED

**BUY IT NOW!**

Click Here To Order

PayPal

MasterCard

VISA

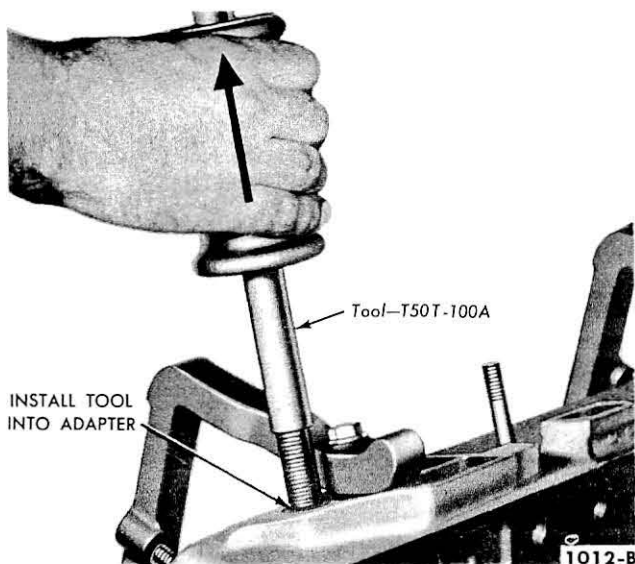

Fig. 12—Temperature Sending Unit Adapter Removal—272 Cubic Inch Engines

the flange facing out (Fig. 11). Drive the plug in until the flange is flush or slightly below the casting surface.

**Temperature Sending Unit Adapter—272 Cubic Inch Engines.** To remove the adapter, thread the impact hammer handle into the adapter, then tighten the lock nut against the adapter (Fig. 12). Remove the adapter by using the slide hammer.

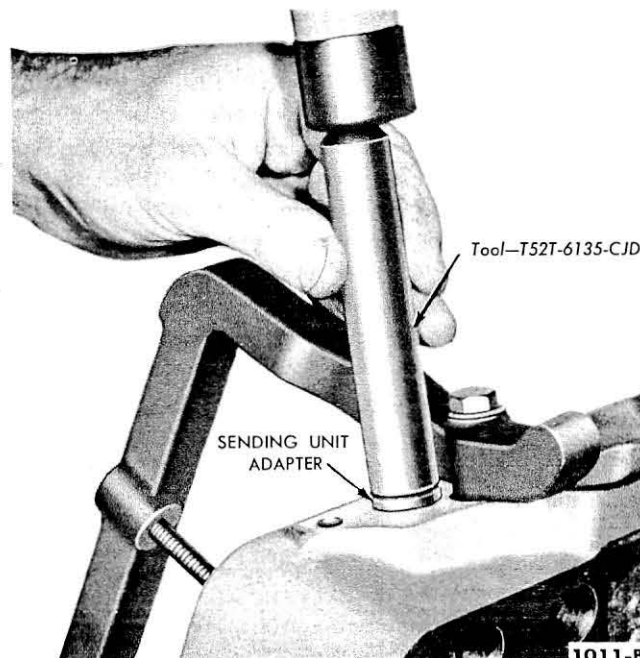

Fig. 13—Temperature Sending Unit Adapter Installation—272 Cubic Inch Engines

Clean the adapter recess thoroughly. Coat the adapter with water resistant sealer and install it with the undercut toward the inside of the cylinder head. Drive the adapter in until it is flush with the casting surface (Fig. 13).

## 5. VALVE MECHANISM

The critical inspection points and tolerances of the valve are illustrated in Fig. 14. Rotating-type intake and exhaust valves are used in the 223 and the ECW-Y 272 cubic inch engines. The intake valves of the ECR 272, 302, and 332 cubic inch engines are the rotating-type, while the exhaust valves are the sodium cooled, free turning-type.

### Cleaning and Inspection

Remove all carbon and varnish from the valve with

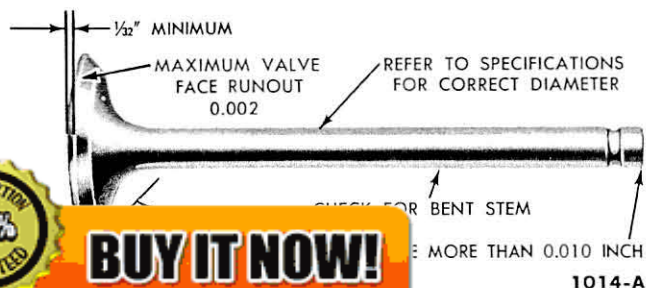

a fine wire brush or buffing wheel.

Inspect the valve face and the edge of the valve head for pits, grooves, scores, or other defects. Inspect the stem for a bent condition and the end of the stem for grooves or scores. Check the valve head for signs of burning or erosion, warpage, and cracking. Defects, such as minor pits, grooves, etc., may be removed. Discard valves that are severely damaged. **Do not discard sodium cooled valves with other scrap metal in scrap bins. If a sodium cooled valve is accidentally broken and the sodium exposed, it will react violently upon contact with water resulting in fire and explosion due to chemical action. Therefore, these valves should be handled with care and disposed of by being buried in the ground in an area not subjected to excavation, or dropped into deep natural water in a section not subjected to dredging.**

Inspect the valve springs, valve spring retainers, locks, and sleeves for defects. Discard any defective parts.

**VALVE FACE RUNOUT.** Check the valve face runout

**100% SATISFACTION GUARANTEED**

**BUY IT NOW!**

**Click Here To Order**

PayPal, American Express, Discover, MasterCard, VISA

(Fig. 15). The wear limit for runout is 0.002 inch total indicator reading.

**VALVE STEM CLEARANCE.** Check the valve stem to valve guide clearance of each valve in its respective valve guide with the tool shown in Fig. 16 or its equivalent.

Install the tool on the valve stem until fully seated and tighten the set screw, then permit the valve to drop away from its seat until the tool contacts the upper surface of the valve guide. Position a dial indicator with a flat tip against the center portion of the spherical section of the tool at approximately 90° to the valve stem. Move the tool back and forth on a plane that parallels normal rocker action and take the indicator reading without lifting the tool from the valve guide upper surface. Divide the indicator reading by 2 (division factor of the tool) to obtain the actual stem clearance.

The wear limit for intake valve stem clearance is 0.0045 inch. The wear limit for the exhaust valve stem clearance is 0.0065 inch (223 and ECW-Y 272 cubic inch engines) or 0.0055 inch (ECR 272, 302, and 332 cubic inch engines). If the clearance approaches the wear limit, try a new valve.

**VALVE SPRING PRESSURE.** Check the spring for proper pressure (Fig. 17). The springs should exert a pressure of 64 pounds when compressed to 1.780 inches (wear limit) or a pressure of 145 pounds when compressed to 1.390 inches (wear limit). Weak valve springs cause poor engine performance; therefore, if the pressure of any spring approaches the wear limit, replace the spring.

**VALVE SPRING ASSEMBLED HEIGHT.** Correct valve

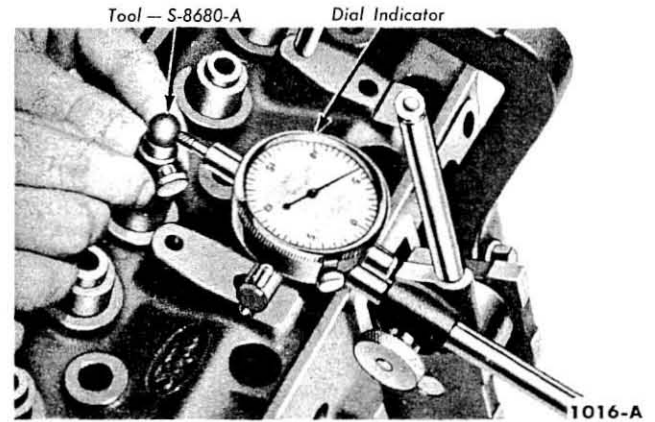
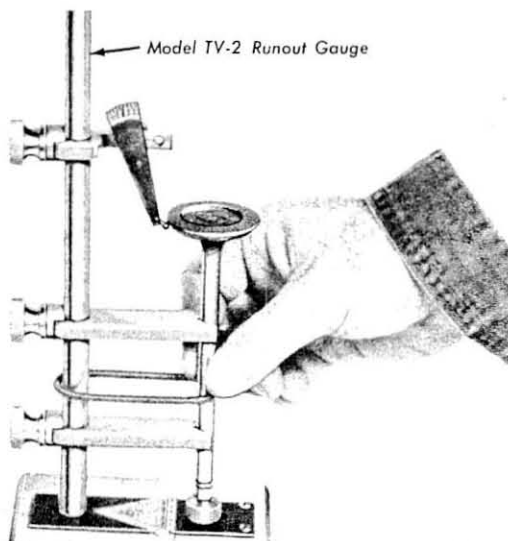

Fig. 16—Valve Stem Clearance—Typical

spring load is necessary for efficient high speed engine operation; therefore, the assembled height of the spring installed in the engine should be measured (Fig. 18).

Use dividers to measure the assembled height from the surface of the cylinder head spring pad to the underside of the spring retainer. Check the dividers against a scale. If the assembled height is  $1\frac{3}{16}$  inches or greater, install the necessary 0.030-inch thick spacer(s) between the cylinder head spring pad and the valve spring to bring the assembled height to the recommended dimension of  $1\frac{25}{32}$ - $1\frac{13}{16}$  inches. **Do not install spacers unless necessary. Use of spacers in excess of recommendations will result in overstressing the valve springs which will lead to excessive load loss and spring breakage.**

**VALVE SPRING SQUARENESS.** Check each spring



1015-A

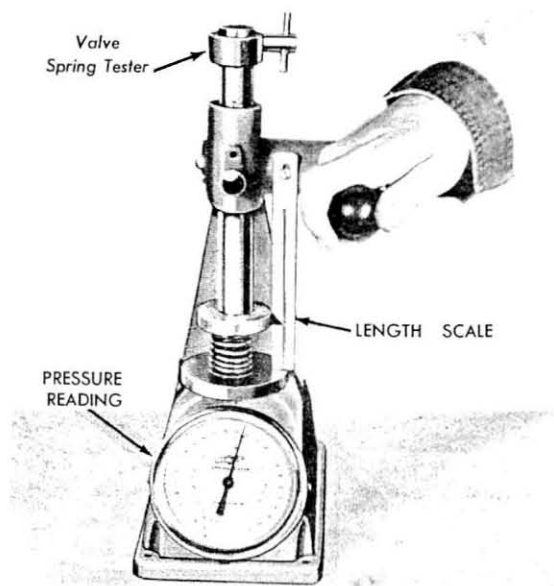

1017-A

Fig. 17—Valve Spring Pressure

**100% SATISFACTION GUARANTEED**

**BUY IT NOW!**

**Click Here To Order**

PayPal   American Express   Discover   MasterCard   VISA

t—Typical

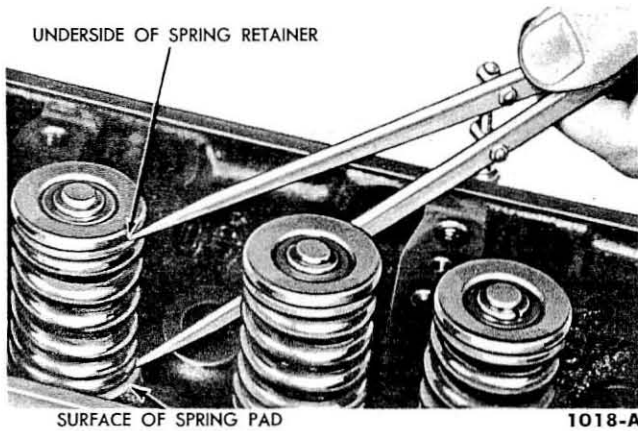

Fig. 18—Valve Spring Assembled Height—Typical

for squareness using a steel square and a surface plate (Fig. 19). Stand the spring and square on end on the surface plate. Slide the spring up to the square. Revolve the spring slowly and observe the space between the top coil of the spring and the square. If the spring is out of square more than  $\frac{1}{16}$  inch, replace it.

**FREE TURNING VALVE TO CAP CLEARANCE.** The free turning-type exhaust valve (ECR 272, 302, and 332 cubic inch engines) requires a clearance of 0.0002-0.004-inch between the end of the valve stem and the inside of the cap (Fig. 20). This is necessary so that the cap can carry the valve spring pressure permitting the valve to rotate. The clearance can be measured before the valve is installed with a micro gage (Fig. 21). If the clearance is greater than 0.004 inch, reduce the clearance by lapping the open end of the cap on a smooth surface.

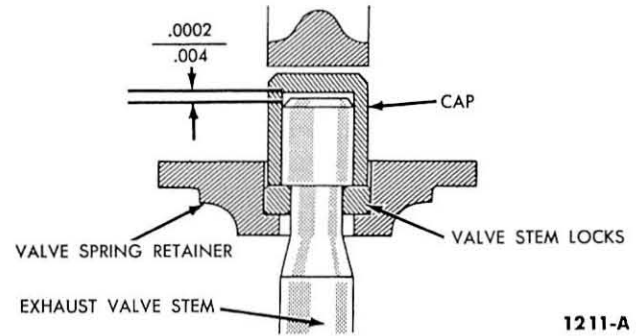

Fig. 20—Valve Clearance—Free Turning Valve

### Refacing Valves

The valve refacing operation should be closely coordinated with the valve seat refacing operation so that the finished angle of the valve face will match the valve seat. This is important so that the valve and seat will have a good compression and vacuum tight fit. Be sure that the refacer grinding wheels are properly dressed.

If the valve face runout is excessive and/or to remove pits and grooves, grind the valve to a true 45° angle. Remove only enough stock to correct the runout or to clean up the pits and grooves. If the edge of the valve head is less than  $\frac{1}{32}$  inch after refacing, replace the valve as the valve will run too hot in the engine.

Grind off all grooves or score marks from the end of the valve stem, then chamfer as necessary. Do not remove more than 0.010 inch from the stem.

After refacing the valves, it is good practice to lightly lap in the valves with a medium grade lapping compound to match the seats. Be sure to remove all the compound from the valve and seat after the lapping operation.

### Select Fitting Valves

If the valve stem to valve guide clearance approaches the wear limit, it is recommended that the valve guide be reamed for the next oversized valve stem. Valves with oversize stem diameters of 0.003, 0.015, and 0.030 inch are available for service. *Always grind the valve seat when the valve guide is reamed.*

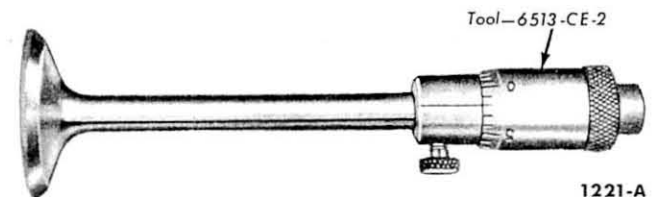

Fig. 21—Measuring Valve To Cap Clearance—Free Turning Valve

**100% SATISFACTION GUARANTEED**

**BUY IT NOW!**

[Click Here To Order](#)

PayPal   American Express   Discover   MasterCard   VISA

### Valve Lash Adjustment

Reference is made in the procedure for a preliminary (cold) valve lash adjustment to placing No. 1 piston on top dead center (T.D.C.) at the end of the compression stroke. Number 1 piston is on T.D.C. at the end of the compression stroke when both valves are closed and the timing mark on the crankshaft damper is in line with the timing pointer.

Step-type feeler gauges (“go” and “no go”) can be used to obtain the proper clearance (Fig. 22).

Valve lash is adjusted by means of the self locking adjusting screw located on the push rod end of the rocker arm. The adjusting screw has an integral hex head and special threads which provide an interference fit in the rocker arm. The first three threads are lead threads. Interference is not reached until the center portion of the adjusting screw threads are in full contact with the threads in the rocker arm. When the interference area is reached, it should take a minimum of 3 foot-pounds (36 inch-pounds) to turn the screw further.

It is very important that the valve lash be held as close as possible to the correct specifications. If the lash is set too close, the valves will open too early and close too late resulting in rough engine idle. Also, burning and warping of the valves will occur because they cannot make firm contact with the seats long enough to cool properly. If the lash is excessive, it will cause the valves to open too late and close too early causing valve bounce. In addition, damage to the cam lobe is likely because the tappet foot will not follow the pattern of the cam lobe causing a shock contact between these two parts. Valve lash specifications are given in Table 4.

If the cylinder head or the rocker mechanism has been removed and installed, it will be necessary to make a preliminary (cold) valve lash adjustment before starting the engine. If the adjustment is made for an engine tune-up, follow the final adjustment procedure.

**6-CYLINDER ENGINE.** The cylinders are numbered from front to rear, 1-2-3-4-5-6. The valves are arranged from front to rear, E-I-I-E-I-E-E-I-E-I-E-E.

**Preliminary Adjustment.** Turn all the adjusting screws until interference is noted, then check the torque

required to turn the screw further. If the torque required to turn a screw is less than 3 foot-pounds (36 inch-pounds), try a new self locking adjusting screw. If this is still unsatisfactory, replace the rocker arm and adjusting screw.

Make two chalk marks on the crankshaft damper (Fig. 23). Space the marks approximately 120° apart so that with the timing mark, the damper is divided into three equal parts (120° represents 1/3 of the distance around the damper circumference).

Rotate the crankshaft until No. 1 piston is near T.D.C. at the end of the compression stroke. Adjust the intake and exhaust valve lash for No. 1 cylinder.

Repeat this procedure for the remaining set of valves, turning the crankshaft 1/3 turn at a time, in the direction of rotation, while adjusting the valves in the firing order sequence (1-5-3-6-2-4).

**Final Adjustment.** Run the engine for a minimum of 30 minutes at approximately 1200 rpm to stabilize engine temperatures. With the engine idling, check the valve lash. Adjust the lash if necessary (Fig. 22).

**8-CYLINDER ENGINE.** The cylinders are numbered from front to rear—right bank, 1-2-3-4; left bank, 5-6-7-8. The valves are arranged from front to rear on both banks, E-I-I-E-E-I-I-E.

**Preliminary Adjustment.** Turn all the adjusting screws until interference is noted, then check the torque required to turn the screw further.

If the torque required to turn the screw is less than 3 foot-pounds (36 inch-pounds), try a new self locking

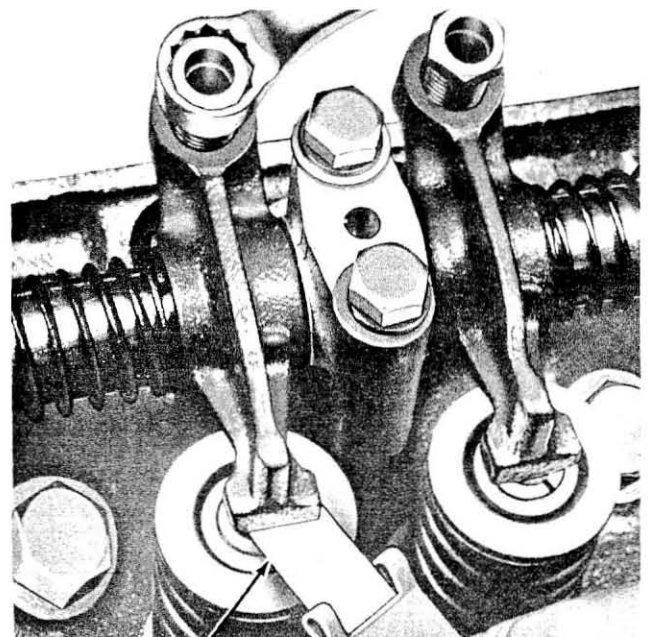

Step-Type Feeler Gauge

1020-A

Fig. 22—Valve Lash Adjustment—Typical

Table 4—Valve Lash Specifications

Engine (Cubic Inch Displacement)	Preliminary (Cold)		Final (Hot)	
	Intake	Exhaust	Intake	Exhaust
1-2	0.010	0.010	0.019	0.019
3-4	0.010	0.010	0.019	0.019
5-6	0.009	0.021	0.009	0.021



**BUY IT NOW!**

**Click Here To Order**



**STEP 1**—SET NO. 1 PISTON ON T.D.C. AT END OF COMPRESSION STROKE ADJUST NO. 1 INTAKE & EXHAUST  
**STEP 4**—ADJUST NO. 6 INTAKE & EXHAUST

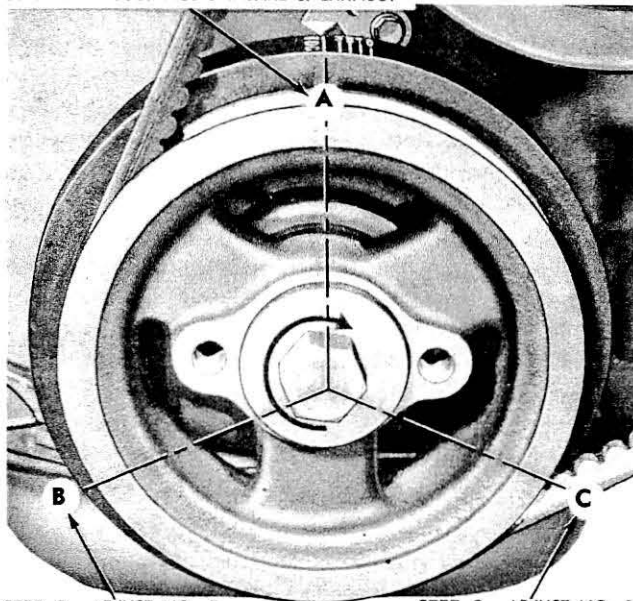

**STEP 2**—ADJUST NO. 5 INTAKE & EXHAUST  
**STEP 5**—ADJUST NO. 2 INTAKE & EXHAUST  
**STEP 3**—ADJUST NO. 3 INTAKE & EXHAUST  
**STEP 6**—ADJUST NO. 4 INTAKE & EXHAUST  
**1421-A**

**Fig. 23—Preliminary Valve Lash Adjustment—6-Cylinder Engine**

adjusting screw. If this is still unsatisfactory, replace the rocker arm and adjusting screw.

Make three chalk marks on the crankshaft damper (Fig. 24). Space the marks approximately 90° apart so that with the timing mark, the damper is divided into four equal parts (90° represents ¼ of the distance around the damper circumference).

Rotate the crankshaft until No. 1 piston is near T.D.C. at the end of the compression stroke, then adjust the following valves:

- |               |              |
|---------------|--------------|
| No. 1—Exhaust | No. 1—Intake |
| No. 4—Exhaust | No. 2—Intake |
| No. 5—Exhaust | No. 7—Intake |

Rotate the crankshaft 180° or ½ turn (this puts No. 4 piston on T.D.C.), then adjust the following valves:

- |               |              |
|---------------|--------------|
| No. 6—Exhaust | No. 4—Intake |
| No. 8—Exhaust | No. 5—Intake |

**STEP 1**—SET NO. 1 PISTON ON T.D.C. AT END OF COMPRESSION STROKE—ADJUST NO. 1, 4, 5, EXHAUST & NO. 1, 2, 7 INTAKE

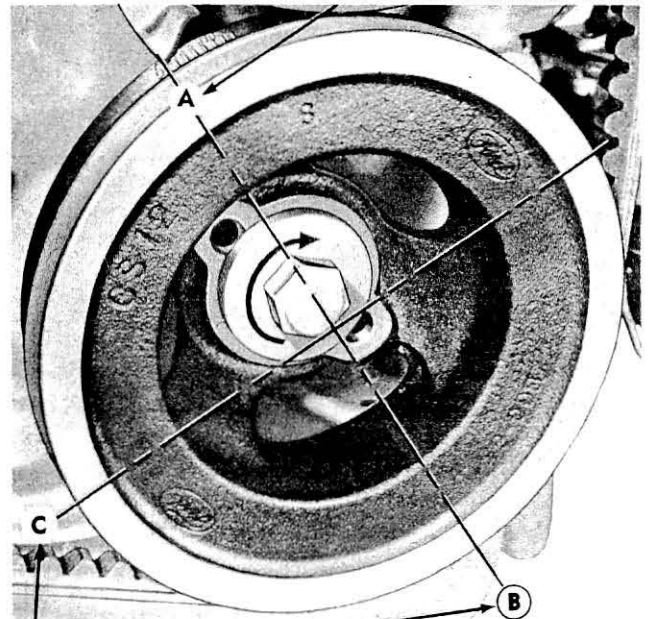

**STEP 2**—ADJUST NO. 6 & 8 EXHAUST & NO. 4 & 5 INTAKE  
**STEP 3**—ADJUST NO. 2, 3, 7 EXHAUST & NO. 3, 6, 8 INTAKE  
**1022-A**

**Fig. 24—Preliminary Valve Lash Adjustment—8-Cylinder Engine**

Rotate the crankshaft 270°, or ¾ turn from 180° (this puts No. 3 piston on T.D.C.), then adjust the following valves:

- |               |              |
|---------------|--------------|
| No. 2—Exhaust | No. 3—Intake |
| No. 3—Exhaust | No. 6—Intake |
| No. 7—Exhaust | No. 8—Intake |

**Final Adjustment.** Run the engine for a minimum of 30 minutes at approximately 1200 rpm to stabilize engine temperatures. With the engine idling, check the valve lash. Adjust the lash if necessary (Fig. 22).

### Valve Timing

The valve timing should be checked when poor engine performance is noted and all other checks, such as carburetion, ignition timing, etc. fail to locate the cause of the trouble.

**Table 5—Valve Timing Specifications**

Engine (Cubic Inch)	Intake Valve				Exhaust Valve			
	Opens		Closes		Opens		Closes	
	Crankshaft Degrees	Cam Lift	Crankshaft Degrees	Cam Lift	Crankshaft Degrees	Cam Lift	Crankshaft Degrees	Cam Lift
	16		53° A.B.D.C.	0.019	61° B.B.D.C.	0.016	9° A.T.D.C.	0.019
	5		58° A.B.D.C.	0.018	66° B.B.D.C.	0.014	10° A.T.D.C.	0.017
	0		62° A.B.D.C.	0.012	56° B.B.D.C.	0.017	20° A.T.D.C.	0.019



**BUY IT NOW!**

**Click Here To Order**



Before the valve timing is checked, check for a bent timing pointer. Bring the No. 1 piston to T.D.C. on the compression stroke and see if the timing pointer is aligned with the T.D.C. mark on the damper.

If the valve timing is not within specifications, check the timing chain, camshaft sprocket or gear, crankshaft sprocket or gear, camshaft, and crankshaft in the order of accessibility.

To check the valve timing with the engine installed in the truck, proceed as follows:

Install a quadrant on the crankshaft damper. Back off the No. 1 intake valve adjusting screw, then slide the rocker arm assembly to one side and secure it in this position. Make sure the push rod is in the tappet

socket, then install a dial indicator in such a manner as to have the actuating point of the indicator in the push rod socket and in the same plane as the push rod movement (Fig. 29). Turn the crankshaft damper slowly in the direction of rotation until the tappet is on the heel of the cam lobe. At this point the push rod will be in its lowest position. Zero the dial indicator and continue turning the crankshaft slowly in the direction of rotation until the dial indicator registers the specified camshaft lobe lift (Table 5).

Compare the crankshaft degrees indicated on the quadrant with specifications (Table 5). After the valve opening is checked, continue to rotate the engine to check the valve closing.

## 6. TIMING CHAIN, TIMING GEARS, CAMSHAFT, AND BEARINGS

### Timing Chain—223 and 272 Cubic Inch Engines

**CLEANING AND INSPECTION.** Clean all parts in solvent and dry them with compressed air. Inspect the chain for broken links and the sprockets for cracks, worn or damaged teeth. It is recommended that all the components be replaced if any one item needs replacement.

**DEFLECTION CHECK.** Rotate the crankshaft in a

clockwise direction (as viewed from the front) to take up the slack on the left side of the chain. Establish a reference point on the block and measure from this point to the chain (Fig. 25). Rotate the crankshaft in the opposite direction to take up the slack on the right side of the chain, then force the left side of the chain out with the fingers and measure the distance between the reference point and the chain. The deflection is the difference between the two measurements. If the deflection exceeds  $\frac{1}{2}$  inch, replace the timing chain and/or sprockets.

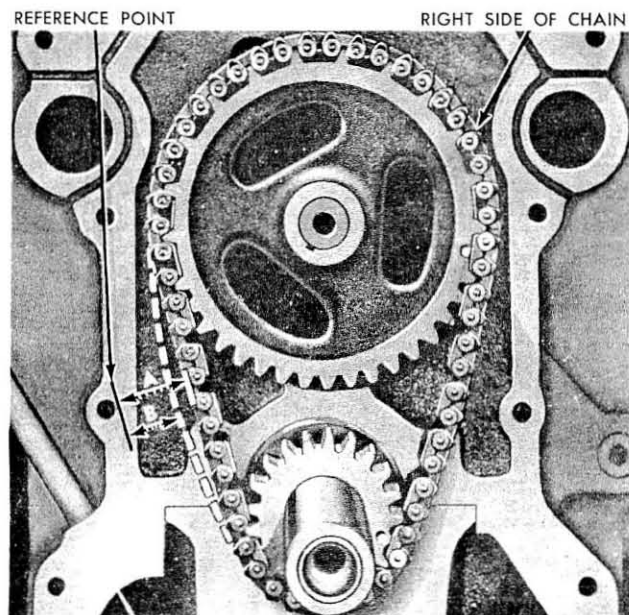

TAKE UP SLACK ON LEFT SIDE. ESTABLISH A REFERENCE POINT  
MEASURE DISTANCE A. TAKE UP SLACK ON RIGHT SIDE  
DEFLECT CHAIN AND MEASURE

1024-A

### Timing Gears—302 and 332 Cubic Inch Engines

**CLEANING AND INSPECTION.** Clean the gears in solvent. Note the condition of the gear teeth. If the

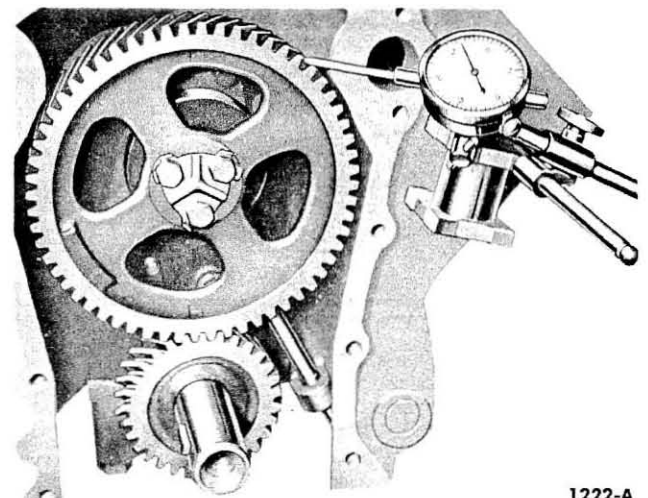

1222-A

Fig. 26—Camshaft Gear Backlash—302 and 332 Cubic Inch Engines

1024-A

223 and 272 Cubic Inch Engines

**BUY IT NOW!**

Click Here To Order

PayPal

MasterCard

VISA

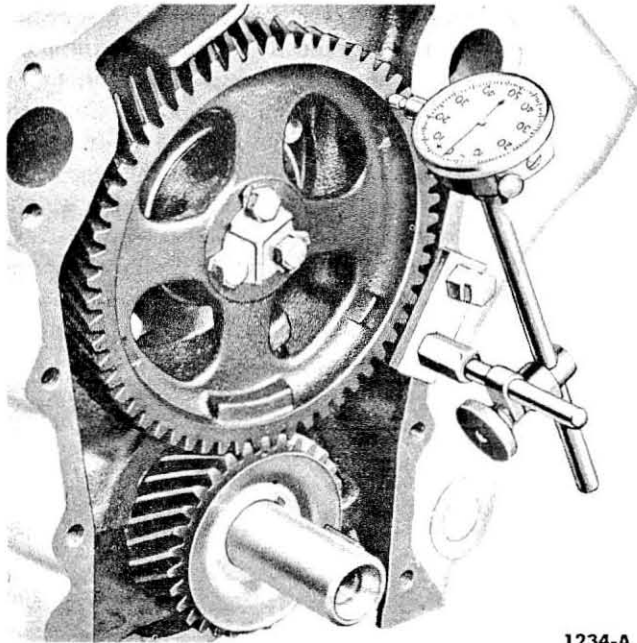

1234-A

**Fig. 27—Camshaft Gear Runout—302 and 332 Cubic Inch Engines**

teeth are scored or the contact pattern on the teeth is uneven, replace the gear(s). It is good practice to replace both gears if either gear needs replacing.

**BACKLASH.** Check the backlash between the camshaft gear and the crankshaft gear with a dial indicator (Fig. 26). Hold the gear firmly against the block while making the check. The backlash limits are 0.002-0.004 inch.

**RUNOUT.** Check the camshaft and crankshaft gear

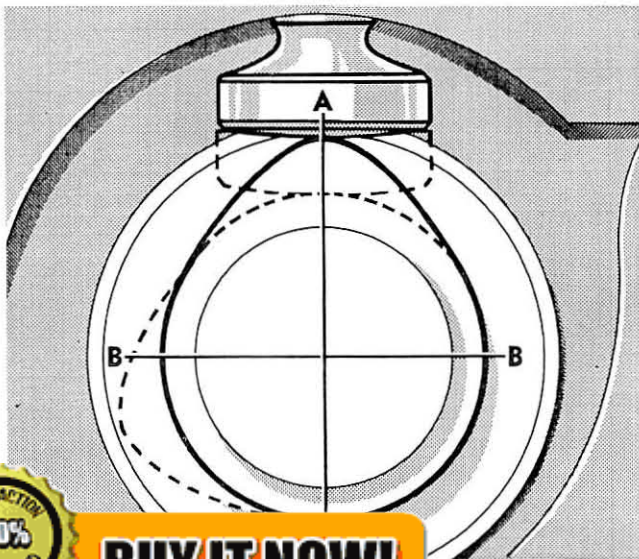

1025-A

Measurement

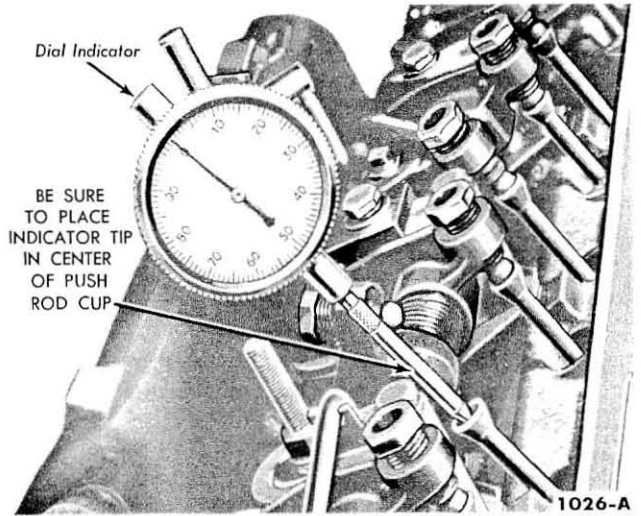

1026-A

**Fig. 29—Camshaft Lobe Lift**

runout with a dial indicator (Fig. 27). The camshaft gear runout should not exceed 0.006 inch and the crankshaft gear runout should not exceed 0.007 inch. If the gear runout is excessive, remove the gear and clean any burrs from the shaft, or replace the gear and/or gears.

## Camshaft and Bearings

**CLEANING AND INSPECTION.** Clean the camshaft

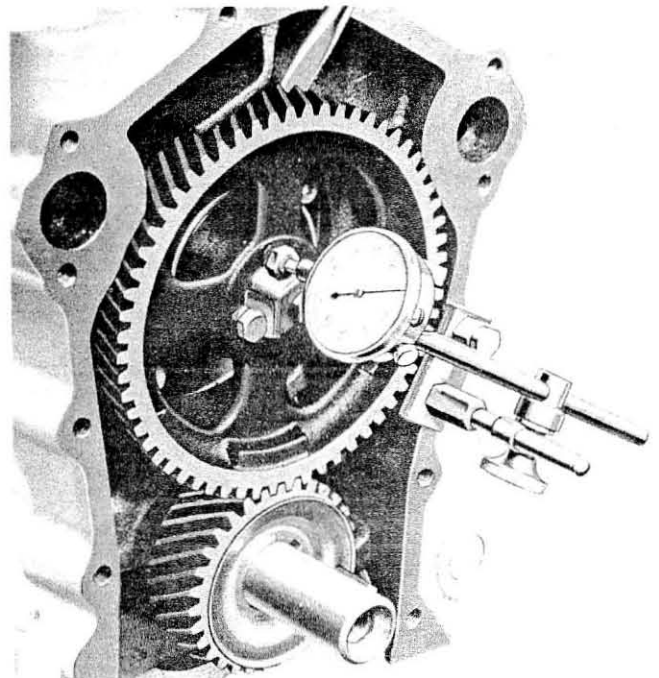

1236-A

**Fig. 30—Camshaft End Play—302 and 332 Cubic Inch Engines**

**100% SATISFACTION GUARANTEED**

**BUY IT NOW!**

**Click Here To Order**

PayPal   American Express   Discover   MasterCard   VISA

in solvent and wipe dry. Inspect the camshaft lobes for pitting, scoring, and signs of abnormal wear. Lobe wear characteristics may result in pitting in the general area of the nose portion of the lobe. This pitting is not detrimental to the operation of the camshaft, therefore, it should not be replaced until the lobe lift loss has exceeded 0.005 inch. The lift of suspected worn lobes should be checked by measuring over the top of the lobe with a micrometer and subtracting the measurement of the base circle diameter (Fig. 28).

Check the camshaft journal to bearing clearances by measuring the diameter of the journals and the I.D. of the bearings. The bearing clearance wear limit is 0.006 inch. If the clearance approaches the wear limit, the camshaft journals should be ground for undersize bearings or the camshaft replaced, and/or the bearings should be replaced. Bearings are available pre-finished to size for standard and undersize journal diameters. Check the parts catalog for the undersizes available.

Check the distributor drive gear for broken or chipped teeth.

Remove light scuffs, scores, or nicks from the camshaft machined surfaces with a smooth oilstone.

**CAMSHAFT LOBE LIFT (CAMSHAFT INSTALLED).** This procedure is similar to the procedure for checking valve timing. Loosen the valve rocker arm adjusting screw,

then slide the rocker arm assembly to one side and secure it in this position. Make sure the push rod is in the tappet socket, then install a dial indicator in such a manner as to have the actuating point of the indicator in the push rod socket and in the same plane as the push rod movement (Fig. 29). Turn the crankshaft damper slowly in the direction of rotation until the tappet is on the heel of the cam lobe. At this point the push rod will be in its lowest position. Set the dial indicator on zero, then continue to rotate the damper slowly until the push rod is in the fully raised position. Compare the total lift recorded on the indicator with specifications. Continue to rotate the engine until the indicator reads zero. This later step is a check on the accuracy of the original indicator reading.

**CAMSHAFT END PLAY—302 AND 332 CUBIC INCH ENGINES.** Push the camshaft toward the rear of the engine. Place a dial indicator point against a suitable surface on the front end of the camshaft assembly (Fig. 30). Set the dial on zero, then pull the camshaft forward and release it. Compare the dial reading with specifications. The end play wear limit is 0.012 inch.

If the end play is excessive, check the spacer for correct installation. Replace the thrust plate and/or spacer if necessary.

## 7. CRANKSHAFT AND MAIN BEARINGS

The crankshaft is supported by five main bearings in 8-cylinder engines and by four main bearings in 6-cylinder engines. Crankshaft end play in all engines is controlled by the No. 3 main bearing flanges.

### Crankshaft

*Handle the crankshaft with care to avoid possible fractures or damage to the finished surfaces.*

**CLEANING AND INSPECTION.** Clean the crankshaft with solvent, then blow out all oil passages with compressed air.

Inspect main and connecting rod journals for cracks, scratches, grooves, or scores. Dress minor imperfections with an oilstone. Regrind severely marred journals.

Measure the diameter of each journal in at least four places to determine out-of-round, taper, or undersize condition (Fig. 31).

The wear limits for main and connecting rod journals are 0.0005-inch out-of-round and 0.001-inch taper. If the journals approach the wear limits, they should be re-ground or replaced with a new bearing.

Force the crankshaft through a dial indicator so

the tip rests against the crankshaft flange and the indicator axis is parallel to the crankshaft axis (Fig. 32). Set the dial on zero, then push the crankshaft forward and note the reading on the dial. The end play wear limit is 0.012 inch for the 223, 302, and 332 cubic inch engines and 0.010 inch for the 272 cubic inch engines.

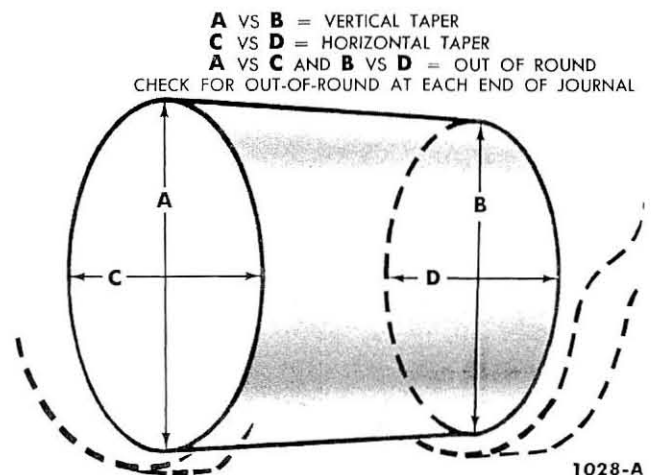

Fig. 31—Crankshaft Journal Measurements



**BUY IT NOW!**

**Click Here To Order**



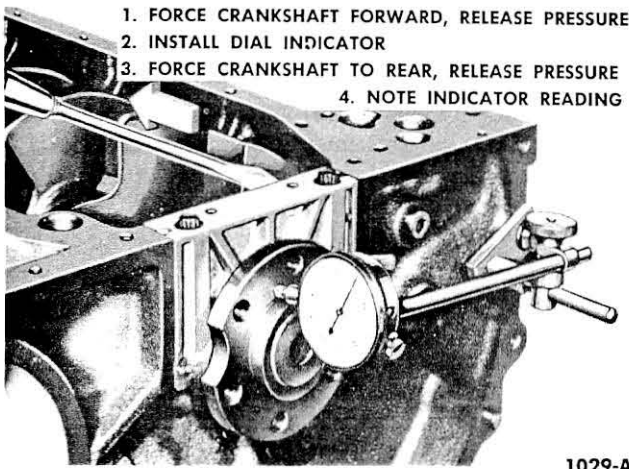

1. FORCE CRANKSHAFT FORWARD, RELEASE PRESSURE
2. INSTALL DIAL INDICATOR
3. FORCE CRANKSHAFT TO REAR, RELEASE PRESSURE
4. NOTE INDICATOR READING

1029-A

Fig. 32—Crankshaft End Play—Typical

If the end play approaches the wear limit, replace the thrust bearing. If the end play is less than the recommended minimum limit (see specifications) inspect the thrust bearing faces for scratches, burrs, nicks, or dirt. If the thrust faces are not defective or dirty, they probably were not aligned properly. Install the thrust bearing and align the faces following the recommended procedure, then recheck the end play.

**REFINISHING JOURNALS.** Grind the journal to give the proper clearance with the next undersize bearing. If the journal will not “clean up” to give the proper clearance with the maximum undersize bearing available, replace the crankshaft.

Always reproduce the same journal shoulder radius that existed originally. Too small a radius will result in fatigue failure of the shaft. Too large a radius will result in bearing failure due to radius ride of the bearing.

After grinding, chamfer the oil holes, then polish the journal with a No. 320 grit polishing cloth and engine

oil. Crocus cloth may also be used as a polishing agent.

## Main Bearings

The main bearing inserts are selective fit and do not require reaming to size upon installation. *Do not file or lap bearing caps or use shims to obtain the proper bearing clearance.*

Selective fit bearings are available for service in standard sizes only. Standard bearings are divided into two sizes and are identified by a daub of “red” or “blue” paint. *Red marked bearings increase the clearance; blue marked bearings decrease the clearance.* Undersize bearings, which are not selective fit, are available for use on journals that have been ground.

**CLEANING AND INSPECTION.** Clean the bearing inserts and cap thoroughly.

Inspect each bearing carefully. Bearings that have a scored, chipped, or worn surface should be replaced. Typical examples of bearing failures and their causes are shown in Fig. 33. Check the clearance of bearings that appear to be satisfactory with Plastigage. Fit new bearings following the recommended procedure.

### CHECKING MAIN BEARING CLEARANCE

**Engine on Workstand.** If the crankshaft has not been removed from the engine, check the clearance of one bearing at a time leaving the other bearings securely fastened.

1. Invert the engine, remove one bearing cap, then wipe all oil from the journal and bearing.

2. Place a piece of Plastigage on the crankshaft journal the full width of the bearing cap and about ¼ inch off center (Fig. 34).

3. Install the cap and tighten the bolts to specifications. *Do not turn the crankshaft while the Plastigage is in place.*

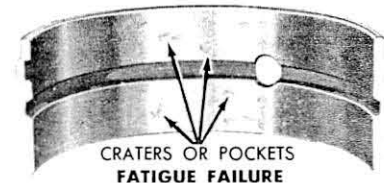
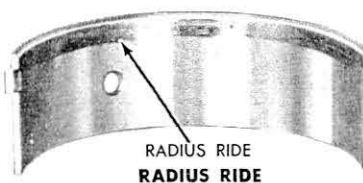
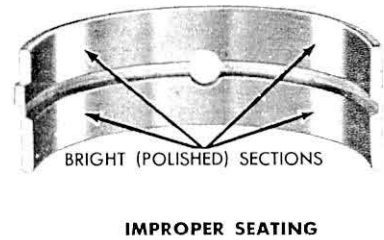
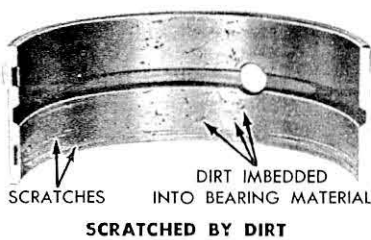

1030-A

Fig. 33—Bearing Failures—Typical

**100% SATISFACTORY GUARANTEED**

**BUY IT NOW!**

**Click Here To Order**

4. Remove the cap, then using the Plastigage scale (Fig. 34) check the width of the Plastigage at the widest point in order to get the minimum clearance. Check the Plastigage at the narrowest point in order to get the maximum clearance. The difference between the two readings is the taper. If the clearance is not within limits, select fit a new bearing.

**Engine in Chassis.** Check the clearance of one bearing at a time, leaving the other bearings securely fastened.

1. Support the crankshaft so its weight will not compress the Plastigage and provide an erroneous reading. Position a small jack so it will bear against the counterweight adjoining the bearing which is being checked.

2. Follow steps 2-4 under "Checking Main Bearing Clearance—Engine on Workstand." In step 2, place the Plastigage on the bearing surface instead of on the journal. Wipe all oil from the bearing and journal.

**FITTING NEW BEARINGS.** *Normally, main bearing journals wear evenly and are not out-of-round. However, if a bearing is being fitted to an out-of-round journal, be sure to fit the bearing to the maximum diameter of the journal. If the bearing is fitted to the minimum diameter with minimum clearance, interference may result, causing an early failure. It is not recommended that bearings be fitted to a crankshaft journal which is more than 0.0005 inch out-of-round.*

**Engine on Workstand.** If the crankshaft has not been removed from the engine, replace one bearing at a time leaving the other bearings securely fastened. When replacing standard bearings, it is good practice to first try to obtain the proper clearance with two blue bearing halves.

1. Invert the engine, remove the bearing cap and the upper half of the bearing to which new bearings are to be fitted.

2. Install the new bearing inserts and check the clearance. *When installing bearings, do not get dirt or other foreign matter under the inserts. In time, the dirt may distort the bearing and cause bearing failures.*

3. If the clearance is *less* than the specified limits, try two red bearing halves or a combination of red and blue.

4. If the standard bearings do not bring the clearance within the desired limits, *grind the crankshaft journals.*

Replace the bearing at a time leaving the other bearings securely fastened. Follow

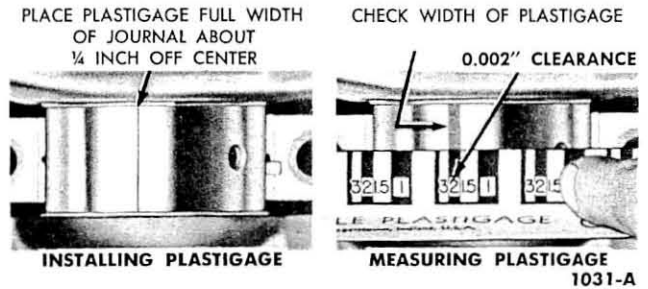

Fig. 34—Installing and Measuring Plastigage

steps 2-4 under "Fitting New Bearings—Engine On Workstand." Remember to support the crankshaft when checking the clearance of the new bearings.

## Rear Main Bearing Oil Seal Replacement

1. Remove the oil seals from the cylinder block and seal retainer or bearing cap. Clean the seal grooves.

2. Install the new seal, firmly packing it, in the cylinder block (Fig. 35). After installation, cut the seals flush without any frayed edges overlapping, if necessary.

3. Firmly pack the new journal seal in the retainer or bearing cap (Fig. 36). After installation cut the seals flush, if necessary.

4. Coat the rear oil seal retainer to block mating face with sealer, install the retainer and tighten the bolts to 23-28 foot-pounds torque.

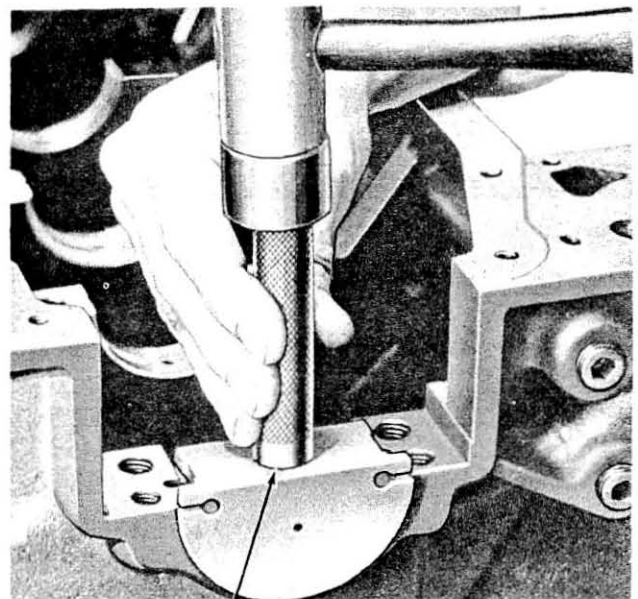

Tool— T52L-6701-AGD (223 OR 272 CUBIC INCH ENGINE)

Tool— T52T-6701-AJD (302 OR 332 CUBIC INCH ENGINE)

1254-A

Fig. 35—Seal To Block Installation—Typical

**100% SATISFACTION GUARANTEED**

**BUY IT NOW!**

**Click Here To Order**

PayPal   American Express   Discover   MasterCard   VISA

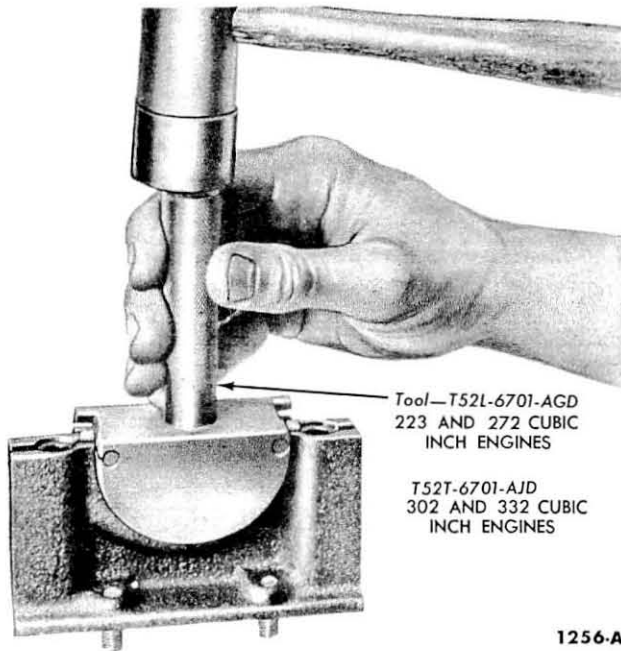

Fig. 36—Seal To Retainer Installation—Typical

5. Dip the retainer side seals in light engine oil, then immediately install them in the grooves. It may be necessary to tap the seals into place for the last 1/2 inch of travel. Do not cut the projecting end of the seals. *Do not use sealer on the side seals. The seals are designed to expand when dipped in oil. Using sealer may retard this expansion.*

6. Check the retainer or bearing cap side seals for leaks by squirting a few drops of oil into the parting lines between the cap or retainer and the cylinder block from the outside. Blow compressed air against the seals from the inside of the block. If air bubbles appear in

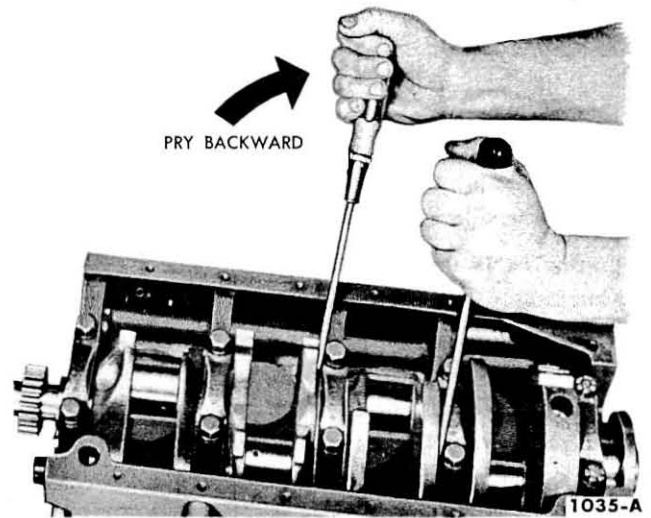

Fig. 38—Pry Cap Backward

the oil, it indicates possible oil leakage. *The above test should not be performed on newly installed seals until sufficient time has been allowed for the seals to expand into the seal grooves.*

### Thrust Bearing Alignment

1. Install all the main bearing caps, except the thrust bearing cap, and tighten the bolts to specifications.
2. Install the thrust bearing cap with the bolts finger tight, then pry the crankshaft forward against the thrust surface of the upper half of the bearing (Fig. 37).
3. Hold the crankshaft forward and pry the thrust bearing cap to the rear (Fig. 38). This will align the thrust surfaces of both halves of the bearing.
4. Retain the forward pressure on the crankshaft, and tighten the cap bolts to specifications (Fig. 39).
5. Check the crankshaft end play.

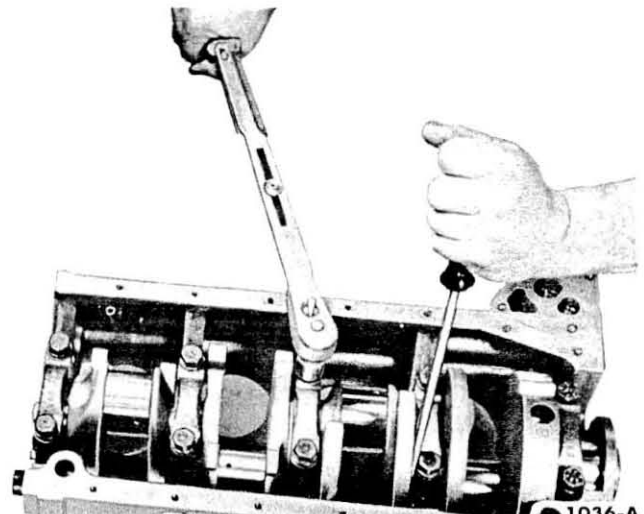

Fig. 39—Tighten Cap

**100% SATISFACTION GUARANTEED**

**BUY IT NOW!**

**Click Here To Order**

ard

## 8. FLYWHEEL

### Conventional Flywheel

The flywheel and ring gear are a shrink fit and are replaceable as separate parts.

**INSPECTION.** Inspect the flywheel for cracks, heat check, or other defects that would make it unfit for further service. Machine the friction surface of the flywheel if it is scored or worn. If it is necessary to remove more than 0.045 inch of stock from the original thickness, replace the flywheel.

Inspect the ring gear for worn, chipped, or cracked teeth. If the teeth are damaged, replace the ring gear.

With the flywheel installed on the crankshaft, check the flywheel face runout.

**FLYWHEEL FACE RUNOUT.** Install a dial indicator so that the tip bears against the flywheel face (Fig. 40). Turn the flywheel, making sure that it is full forward or rearward so that crankshaft end play will not be indicated as flywheel runout.

If the runout exceeds 0.010 inch, remove the flywheel and check for burrs between the flywheel and the face of the crankshaft mounting flange. If no burrs exist, check the runout of the crankshaft mounting flange. Replace the flywheel or machine the crankshaft flywheel face if the mounting flange runout is excessive.

**RING GEAR REPLACEMENT.** Heat the defective ring gear with a blow torch on the engine side of the gear, then knock it off the flywheel. *Do not hit the flywheel when removing the ring gear.*

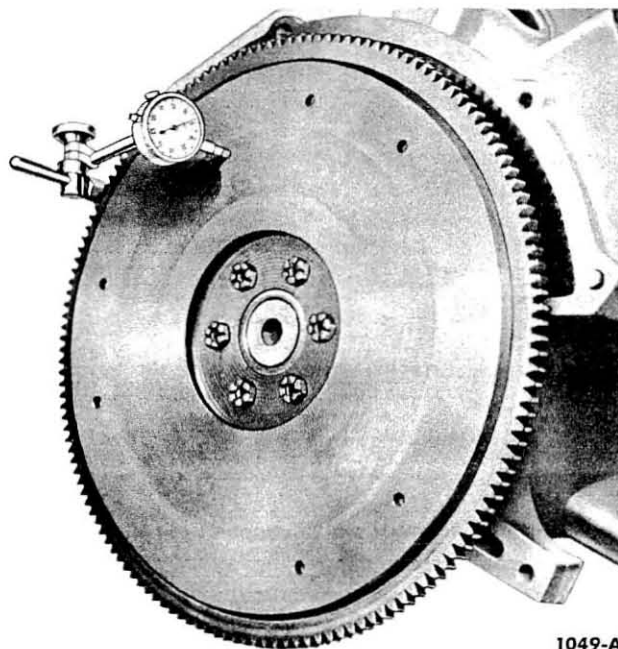

Fig. 40—Flywheel Face Runout—Typical

Heat the new ring gear evenly until the gear expands enough to slip onto the flywheel. Make sure the gear is seated properly against the shoulder. *Do not heat any portion of the gear to a temperature higher than 500° F. If this limit is exceeded, the temper will be removed from the ring gear teeth.*

## 9. CONNECTING RODS AND BEARINGS

The connecting rods and related parts should be carefully inspected and checked for conformance to specifications. Various forms of engine wear caused by these parts can be readily identified.

A shiny surface on the pin boss side of the piston usually indicates that a connecting rod is bent or the piston pin hole is not in proper relation to the piston skirt and ring grooves (Fig. 41).

Abnormal connecting rod bearing wear can be caused by either a bent connecting rod, an improperly machined pin, or a tapered connecting rod bore (Fig. 42).

Twisted rods will not create an easily identifiable wear pattern. Twisted rods will cause uneven wear on the piston, rings, and rod

assembly and may be the cause of excessive oil consumption.

### Cleaning and Inspection

Remove the bearings from the rod and cap (identify them if they are to be used again). Clean the connecting rod in solvent, including the rod bore and the back of the inserts. *Do not use a caustic cleaning solution.* Blow out all passages with compressed air.

Inspect the rods for signs of fractures and the bearing bores for out-of-round and taper. The recommended maximum limit for out-of-round and taper is 0.0004 inch. If the bore exceeds these limits and/or if the rod is fractured, it should be replaced.

**SATISFACTION  
100%  
GUARANTEED**

**BUY IT NOW!**

**Click Here To Order**

PayPal   American Express   Discover   MasterCard   VISA

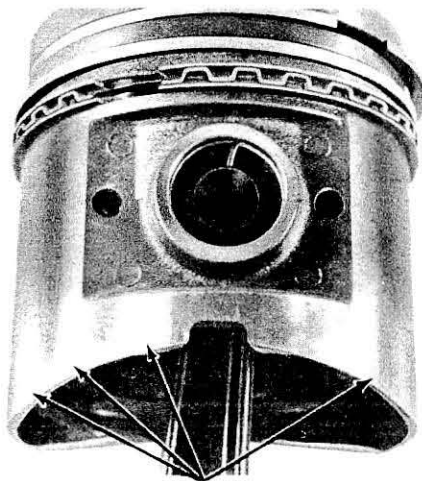

PISTON WEAR CAUSED BY BENT ROD  
OR MISALIGNED PISTON PIN HOLE

1045-A

**Fig. 41—Wear Pattern on Piston Pin Boss Surface—  
Typical**

Check the piston pin to connecting rod bushing clearance. Replace the connecting rod if the bushing is so worn that it cannot be reamed or honed for an oversize pin.

Replace defective connecting rod nuts and bolts.

Inspect each connecting rod crankshaft journal for cracks, scratches, grooves, or scores. Dress minor imperfections with a smooth oilstone. Check each journal for out-of-round, taper, or undersize. If the journals exceed the maximum limits and/or if they are severely marred, they should be ground to size for the next undersize bearing.

Inspect each bearing carefully. Replace bearings that have a scored, chipped, or worn surface. For the different types of bearing failures and their causes refer to Fig. 33. Check the clearance of bearings that appear to be satisfactory. Fit new bearings where necessary, following the recommended procedure.



1046-A

Connecting Rod Bearing

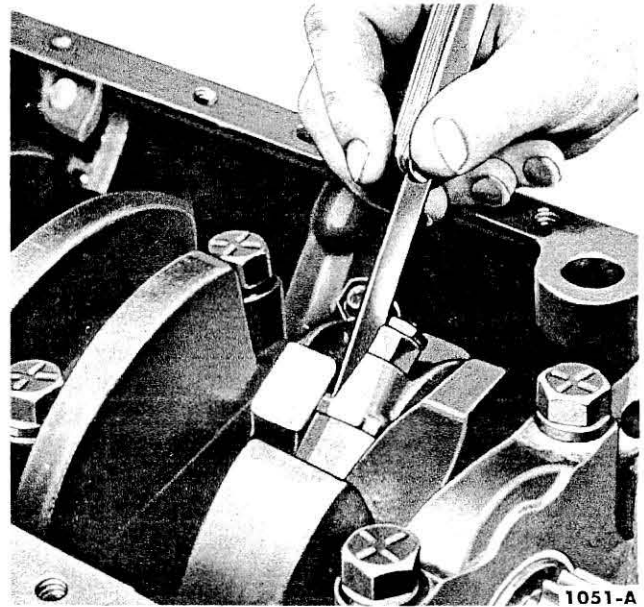

1051-A

**Fig. 43—Connecting Rod Side Clearance**

After the connecting rods are assembled to the piston, check the rods for bend or twist on a suitable alignment fixture. Follow the instructions of the fixture manufacturer. The recommended maximum limit for twist total difference is 0.012 inch and 0.004 inch for bend total difference using an 8-inch arbor and measured on each side. If the bend and/or twist is excessive, the rod should be straightened or replaced.

### Checking Connecting Rod Bearing Clearance

1. Wipe all oil from the journal and bearing.
2. Place a piece of Plastigage on the lower bearing surface the full width of the cap and about  $\frac{1}{4}$  inch off center.
3. Install the cap and tighten the rod bolts to 45-50 foot-pounds torque. **Do not turn the crankshaft while the Plastigage is in place.**
4. Remove the cap, then using the Plastigage scale check the width of the Plastigage at the widest point in order to get the minimum clearance. Check the Plastigage at the narrowest point in order to get the maximum clearance. The difference between the two readings is the taper. If the clearance is not within limits, select fit a new bearing.

### Fitting New Bearings

The connecting rod bearings are available for service in standard sizes and undersizes for use on journals that have been ground. Standard bearings are color coded red or blue. **Red marked bearings increase clearance; blue marked bearings decrease clearance.**



**BUY IT NOW!**

**Click Here To Order**



If the crankpin is out-of-round, be sure to fit the bearing to the maximum diameter of the crankpin. It is not recommended to use bearing shims of any type, or to file or lap the bearing caps in order to adjust the bearing clearance. When replacing standard bearings, it is good practice to first try to obtain the bearing clearance with two blue bearing halves.

1. Remove the rod cap, then remove the bearings from the cap and rod.

2. Clean the oil from the crankshaft journal, and the connecting rod bearing bores.

3. Install the upper bearing into the rod, then pull the rod assembly down firmly on the crankshaft journal. Install the lower bearing in the rod cap. *When installing bearings, do not get dirt or other foreign matter under the inserts. In time, the dirt may distort the*

*bearing and cause bearing failure.*

4. Check the bearing clearance.

5. If the clearance with two blue bearing halves is less than the specified limit try two red bearing halves or a combination of red and blue.

6. If the standard bearings do not bring the clearance within the desired limits, grind the crankpin, then install undersize bearings.

## Checking Connecting Rod Side Clearance

After the connecting rods are installed, check the side clearance between the connecting rods on each crankpin (Fig. 43). The side clearance wear limit is 0.012 inch (6-cylinder engines) or 0.019 inch (8-cylinder engines).

## 10. PISTONS, PINS, AND RINGS

### Cleaning and Inspection

Remove carbon deposits from the piston surfaces and from the underside of the piston head. Clean gum or varnish from the piston skirt, piston pins, and rings with solvent. *Do not use a caustic cleaning solution or a wire brush to clean pistons.* Clean the ring grooves with a ring groove cleaner (Fig. 44). Make sure the oil ring slots (or holes) are clean.

Carefully inspect the pistons for fractures at the ring lands, skirt, and pin bosses, and for scuffed, rough, or scored skirts. If the lower inner portion of the ring grooves have high steps, replace the piston. The step will interfere with ring operation and cause excessive ring side clearance.

Spongy, eroded areas near the edge of the piston top are usually caused by detonation, or pre-ignition. A shiny surface on the thrust surface of the piston, offset from the centerline between the piston pin holes, can be

caused by a bent connecting rod. The normal wear pattern of a piston is shown in Fig. 45. Replace pistons that show signs of excessive wear, wavy ring lands, fractures, and/or damage from detonation or pre-ignition.

Check the piston to cylinder bore clearance with a tension scale and ribbon and the ring side clearance following the recommended procedures.

Replace piston pins showing signs of fracture or etching and/or wear. Check the piston pin fit in the piston and rod bushing.

Replace all rings that are scored, chipped, or cracked. Check the end gap and side clearance. It is good practice to always install new rings when overhauling the engine. *Rings should not be transferred from one piston to another regardless of mileage.*

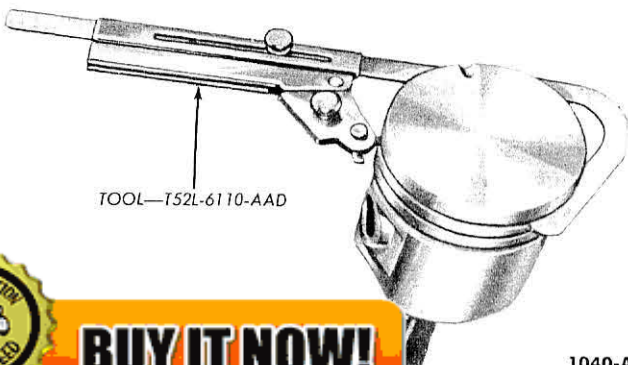

TOOL—T52L-6110-AA0

1040-A

oves—Typical

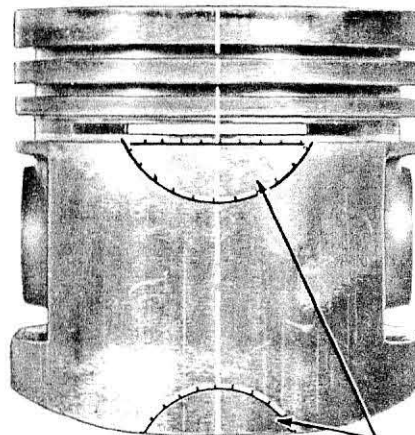

NORMAL WEAR AREAS 1041-A

Fig. 45—Normal Wear Pattern—Typical



**BUY IT NOW!**

**Click Here To Order**



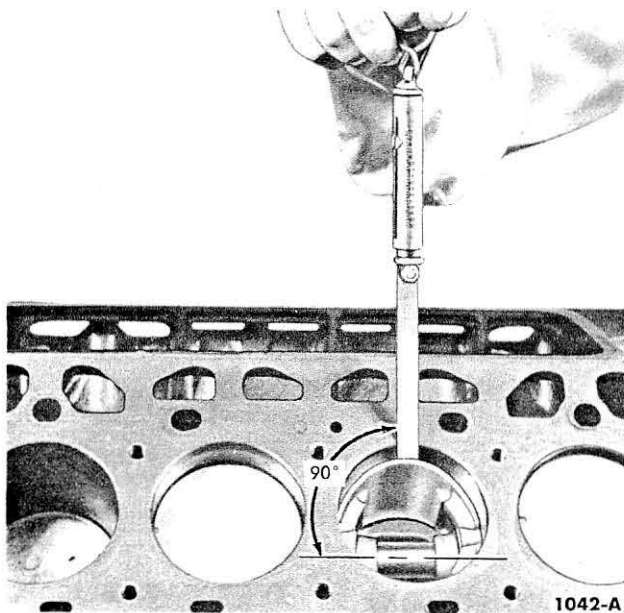

Fig. 46—Checking Piston Fit—Typical

## Fitting Pistons

Pistons are available for service in standard sizes and oversizes for use in cylinders that have been re-bored. Pistons of 0.020, 0.030, 0.040, and 0.060-inch oversize are available for most engines. Check the parts catalog for sizes available.

The piston and cylinder block should be at room temperature (70°F) when the piston fit is checked.



Typical

*After any refinishing operation, allow the cylinder bore to cool before the piston fit is checked.*

Calculate the size piston to be used by taking a bore check (Fig. 51), then select the proper size piston to provide the desired clearance.

Make sure the piston and cylinder bore are clean and dry. Attach a tension scale to the end of a feeler gauge ribbon that is free of dents or burrs. The feeler ribbon should be 1/2-inch wide and of the recommended thickness for the existing condition.

Position the ribbon in the bore so that it extends the entire length of the piston at 90° from the piston pin location. Invert the piston and install it in the bore so that the end of the piston is about 1 1/2 inches below the top of the block and the piston pin is parallel to the crankshaft axis.

Hold the piston and slowly pull the scale in a straight line with the ribbon, noting the pull required to remove the feeler ribbon (Fig. 46).

If the pull is within limits for the existing condition, the piston fit is satisfactory.

If the scale reading is greater than the maximum allowable pull, recheck calculations to be sure that the proper size piston has been selected, check for a damaged piston, then try a new piston.

If the scale reading is less than the minimum allowable pull, recheck calculations before trying another piston. If none can be fitted, refinish the cylinder for the next size piston.

*When a piston has been fitted, mark it for assembly in the cylinder to which it was fitted.*

If the taper and out-of-round conditions of the cylinder bore are within limits, new piston rings will give satisfactory service provided the piston clearance in the cylinder bore is within limits. If the new rings are to be installed in a used cylinder that has not been refinished, remove the cylinder wall "glaze."

Select the proper ring set for the size piston to be used. The rings must be checked for proper gap in the cylinder bore and for the proper side clearance in the piston grooves. First, check each ring for proper gap as follows:

Position the ring in the cylinder bore in which it is going to be used. Push the ring down into the bore area where normal ring wear is not encountered. Use the head of a piston to position the ring in the bore so the ring is square with the cylinder wall. **Use caution to avoid damage to the ring or cylinder bore.** Measure the gap between the ends of the ring with a feeler gauge (Fig. 47).

If the gap is less than the lower limit (see specifications), try another ring set.

After the gap has been checked, install the rings on the piston according to the instructions on the piston ring package using the approved tool. Check the ring



**BUY IT NOW!**

**Click Here To Order**

