

1 9 5 6

# FORD

# truck

# Shop Manual



License #2011747



**BUY IT NOW!**

**Click Here To Order**



D I V I S I O N  
F O R D M O T O R C O M P A N Y

Copyright © 2011, Forel Publishing Company, LLC, Woodbridge, Virginia

All Rights Reserved. No part of this book may be used or reproduced in any manner whatsoever without written permission of Forel Publishing Company, LLC. For information write to Forel Publishing Company, LLC, 3999 Peregrine Ridge Ct., Woodbridge, VA 22192

## **1956 Ford Truck Shop Manual**

**EAN: 978-1-60371-065-7**

**ISBN: 1-60371-065-5**

Forel Publishing Company, LLC

3999 Peregrine Ridge Ct.

Woodbridge, VA 22192

Email address: [sales@ForelPublishing.com](mailto:sales@ForelPublishing.com)

Website: <http://www.ForelPublishing.com>



This publication contains material that is reproduced and distributed under a license from Ford Motor Company. No further reproduction or distribution of the Ford Motor Company material is allowed without the express written permission of Ford Motor Company.

---

## **Note from the Publisher**

This product was created from the original Ford Motor Company's publication. Every effort has been made to use the original scanned images, however, due to the condition of the material; some pages have been modified to remove imperfections.

---

## **Disclaimer**

Although every effort was made to ensure the accuracy of this book, no representations or warranties of any kind are made concerning the accuracy, completeness or suitability of the information, either expressed or implied. As a result, the information contained within this book should be used as general information only. The author and Forel Publishing Company, LLC shall have neither liability nor responsibility to any person or entity with respect to any loss or damage caused, or alleged to be caused, directly or indirectly by the information contained in this book. Further, the publisher and author are not engaged in rendering legal or other professional advice. If legal, mechanical, electrical, or other expert assistance is required, the assistance of a professional should be sought.



1 9 5 6

# FORD

# truck

*Shop  
Manual*



**SATISFACTION  
100%  
GUARANTEED**

**BUY IT NOW!**  
**Click Here To Order**

PayPal American Express Discover MasterCard VISA

September, 1955

**D I V I S I O N**  
**F O R D M O T O R C O M P A N Y**

# FOREWORD

This manual has been prepared to provide information for the proper servicing of 1956 Ford Trucks. The manual should be kept where it will be readily available for reference at all times. The service procedures are accompanied by illustrations of many of the service operations. Disassembled views of some of the truck units are also given.

The manual is divided into five main parts as listed in the Table of Contents on the following pages.

Part ONE—POWER PLANT—is composed of the various truck engines and their related systems, which are, the ignition, fuel, and cooling system.

Part TWO—CHASSIS—includes information on the entire power train (clutch, conventional transmission, Overdrive, drive lines, rear axles, etc.) and the running gear (frames, springs, suspension, brakes, wheels, tires, steering gear, steering linkages, etc.). Service procedures for the Fordomatic transmission are published in a separate manual.

Part THREE—ELECTRICAL AND ACCESSORIES—covers all of the electrical systems and units (except the ignition system) and all of the accessories (except the Overdrive and Fordomatic).

Part FOUR—BODIES—contains information on the maintenance and repair of all body components, including adjustment and alignment of doors, hoods, and fenders. Window glass adjustments are also included in this part.

Part FIVE—MAINTENANCE AND SPECIFICATIONS—includes complete maintenance and lubrication information, and contains all the specifications necessary for properly servicing Ford trucks.

The page headings, throughout the manual, designate the subject matter covered. The heading on each left-hand or even-numbered page indicates the name of the chapter and the heading on each right-hand or odd-numbered page indicates the section covered.

The descriptions and specifications contained in this manual were in effect at the time the book was approved for printing. The Ford Division of Ford Motor Company reserves the right to discontinue models at any time, or change specifications or design, without notice and without incurring obligation.

SERVICE DEPARTMENT  
**FORD DIVISION**  
FORD MOTOR COMPANY



# TABLE OF CONTENTS

Foreword.....	Page	2.
---------------	------	----

## Part ONE—POWER PLANT

### CHAPTER I—GENERAL ENGINE OVERHAUL, INSPECTION, AND REPAIR

Section	Page	Section	Page
1 Trouble Shooting.....	5	6 Timing Chain and Sprockets, Timing Gears and Camshaft.....	21
2 Tune-Up.....	8	7 Flywheel, Crankshaft, and Main Bearings.....	23
3 Engine Removal and Installation.....	10	8 Cylinder Block, Pistons, Piston Rings, and Connecting Rods and Bearings.....	27
4 Intake and Exhaust Manifolds.....	15	9 Oil Pan and Oil Pump.....	31
5 Rocker Mechanisms, Cylinder Heads, Valves, Valve Lash Adjustment and Valve Timing.....	15	10 Exhaust System.....	32

### CHAPTER II—6-CYLINDER ENGINE

1 Manifolds.....	33	6 Flywheel, Crankshaft, and Main Bearings.....	41
2 Cylinder Head and Valves.....	34	7 Connecting Rods and Bearings, Pistons, Pins, and Rings.....	43
3 Crankshaft Damper.....	37	8 Oil Pan, Oil Filter, and Oil Pump.....	45
4 Cylinder Front Cover and Crankshaft Oil Seal.....	38	9 Exhaust System.....	47
5 Sprockets and Timing Chain, Camshaft and Bearings and Tappets.....	38		

### CHAPTER III—8-CYLINDER ENGINES

1 General Information.....	49	7 Sprockets and Timing Chain, Timing Gear, Camshaft and Bearings, and Tappets.....	57
2 Engine Front Support.....	50	8 Flywheel, Crankshaft, and Main Bearings.....	62
3 Manifolds.....	50	9 Connecting Rods and Bearings, Pistons, Pins, and Rings.....	66
4 Cylinder Head and Valves.....	52	10 Oil Pan, Oil Filter, and Oil Pump.....	68
5 Crankshaft Damper.....	55	11 Exhaust System.....	70
6 Cylinder Front Cover and Crankshaft Oil Seal.....	56		

### CHAPTER IV—IGNITION, FUEL, AND COOLING SYSTEMS

1 Ignition System.....	73	8 Four Barrel Carburetor Operation, Adjustments, and Overhaul.....	102
2 Distributor Minor Repair and Adjustments.....	78	9 Fuel Tanks and Lines.....	111
3 Distributor Overhaul.....	80	10 Fuel Pump, Vacuum Boosters, and Fuel Filter.....	112
4 Carburetor Operation and Adjustments—Single, Dual, and Dual Concentric Carburetors.....	86	11 Governors.....	116
5 Single Barrel Carburetor Overhaul.....	92	12 Fans and Belts.....	118
6 Dual Carburetor Overhaul.....	95	13 Water Pumps.....	119
7 Dual Concentric Carburetor Overhaul.....	97	14 Cooling System—Radiator, Hose, and Thermostat.....	122

## Part TWO—CHASSIS

### CHAPTER I—CLUTCH, TRANSMISSION, AND GEAR SHIFT LINKAGE

1 Trouble Shooting.....	126	7 4-Speed Transmission.....	148
2 Clutch.....	127	8 Light-Duty 5-Speed Transmissions.....	152
3 Flywheel Housing Alignment.....	131	9 Medium-Duty and Heavy-Duty 5-Speed Transmissions.....	157
4 Transmission Cleaning and Inspection.....	133	10 3-Speed Auxiliary Transmission.....	164
5 3-Speed Transmissions.....	134	11 Gear Shift Linkage.....	168
6 Overdrive Transmission.....	139		

### CHAPTER II—REAR AXLES AND DRIVE LINES

Trouble Shooting.....	169	5 Banjo Housing Spiral Bevel Rear Axles.....	187
	170	6 Two-Speed Planetary Rear Axles.....	191
	172	7 Drive Lines.....	203
	180		

### CHAPTER III—TANDEM REAR AXLES

	207	3 Replacement.....	211
	210	4 Overhaul.....	218



## CHAPTER IV—RUNNING GEAR

Section	Page	Section	Page
1 Trouble Shooting	233	6 Shock Absorbers	243
2 Wheel Alignment	235	7 Steering Gear	244
3 Frames	237	8 Steering Linkage	246
4 Front Axles	239	9 Wheels and Tires	248
5 Springs	242	10 Hubs and Bearings	250

## CHAPTER V—POWER STEERING

1 Construction and Operation	255	3 Overhaul	264
2 Inspection and Trouble Shooting	261		

## CHAPTER VI—BRAKES

1 Trouble Shooting	273	5 Air Brakes	307
2 Hydraulic Brakes	276	6 Brake Drums	314
3 Vacuum Boosters	287	7 Parking Brakes	315
4 Air-Hydraulic Unit	302		

# Part THREE—ELECTRICAL AND ACCESSORIES

## CHAPTER I—GENERATING SYSTEM AND BATTERY

1 Trouble Shooting	317	3 Generator Regulator	326
2 Generator	321	4 Battery	332

## CHAPTER II—STARTING SYSTEM

1 Trouble Shooting	335	3 Starter Drive	344
2 Starter and Circuit	338		

## CHAPTER III—LIGHTING SYSTEM, HORNS, AND INSTRUMENTS

1 Trouble Shooting	345	3 Horns	352
2 Lighting System	348	4 Instruments	354

## CHAPTER IV—ACCESSORIES

1 Trouble Shooting	359	3 Heater	366
2 Radio	362	4 Miscellaneous Accessories	368

# Part FOUR—BODIES AND CABS

## CHAPTER I—BODY CONSTRUCTION AND MAINTENANCE

1 Construction Details and Sealer Application	371	2 General Body Maintenance	376
---	-----	----------------------------	-----

## CHAPTER II—INTERIOR TRIM, HARDWARE, AND GLASS

1 Seats and Interior Trim	377	4 Door Locking Mechanism	385
2 Window Regulator and Glass Replacement	381	5 Windshield and Back Window	390
3 Glass Adjustments	385		

## CHAPTER III—REMOVABLE SHEET METAL ASSEMBLIES

1 Front End Sheet Metal	393	4 Hood	396
2 Fenders	394	5 Doors	398
3 Cowl Ventilator	396	6 Running Boards	400

# Part FIVE—MAINTENANCE AND SPECIFICATIONS

## CHAPTER I—MAINTENANCE

1 Preventive Maintenance	403	2 Lubrication	404
--------------------------	-----	---------------	-----

## CHAPTER II—SPECIFICATIONS

and Tires	409	9 Fuel System	421
	410	10 Generating System	421
	411	11 Starting System	422
	413	12 Ignition	422
	415	13 Wiring Diagram	424
	416	14 Paint	425
	419	15 Bulb Chart	425
	421	16 Tools and Equipment	426



# Part ONE

# POWER PLANT

## Chapter

### I

# General Engine Overhaul, Inspection, and Repair

Section		Page
1	Trouble Shooting .....	5
2	Tune-Up .....	8
3	Engine Removal and Installation .....	10
4	Intake and Exhaust Manifolds .....	15
5	Rocker Mechanism, Cylinder Heads, Valves, Valve Lash Adjustment, and Valve Timing .....	15
6	Timing Chain and Sprockets, Timing Gears, and Camshaft .....	21
7	Flywheel, Crankshaft, and Main Bearings .....	23
8	Cylinder Block, Pistons, Piston Rings, and Connecting Rods and Bearings .....	27
9	Oil Pan and Oil Pump .....	31
10	Exhaust System .....	32

Trouble shooting; tune-up; the cleaning, inspection, and repair of component parts; and overhaul instructions are covered in this chapter.

The cleaning, inspection, repair, and overhaul instructions apply only after the parts have been removed from the engine, or in the case of a complete overhaul

after the engine has been disassembled.

To completely disassemble or assemble an engine, follow all the removal or installation procedures contained in the applicable engine chapter. If it is only desired to remove and install an individual part, refer to the applicable section.

## 1. TROUBLE SHOOTING

Trouble shooting is the application of a definite procedure, in a logical sequence, to locate and eliminate the cause of trouble in a particular system or unit. When trouble shooting, first look for the obvious causes of trouble, such as; an empty gas tank, a wet or cold engine, loose or disconnected wiring, or any other item that may cause a temporary defect.

The various factors that affect power plant operation are outlined in this section.

### a. Engine.

Poor engine performance can be attributed to the engine or to forces on the truck that tend to retard its motion. For example, dragging brakes can cause the engine to work harder which will result in poor performance.

Engine performance depends on proper fuel distribution, correctly timed ignition, normal and uniform compression, and an unobstructed flow of exhaust gases.

Engine troubles, their causes, and remedies are discussed under appropriate headings.

to start, the most probable causes are a defective battery or starter. Perform the following checks in the order listed, until the trouble is located.

(a) **CHECK THE BATTERY.** Try the horn or lights. If they do not operate properly, test the battery. Recharge or replace the battery as necessary.

(b) **CHECK THE BATTERY CABLES.** Check for loose or corroded connections at the starter, starter relay, battery, and ground. Clean, tighten, or replace them as necessary.

(c) **CHECK THE STARTER RELAY CIRCUIT.** The starter relay contact surfaces seldom become so badly burned that they will prevent the starter from cranking the engine. However, other wiring may be at fault. Repair as necessary. Refer to Part Three "Electrical and Accessories."

(d) **CHECK THE STARTER OR STARTER DRIVE.** If the above components are not at fault, the trouble is probably in the starter or starter drive. If the starter is running, but not engaging the flywheel, remove the starter and make the necessary repairs to the starter drive. In rare cases, the starter drive may lock up with the flywheel. This can be corrected by loosening the starter and releasing the starter drive. If the starter does not

K. If the starter  
it over too slowly

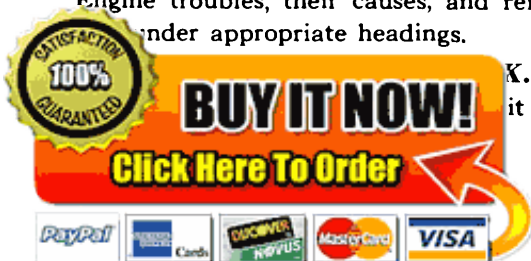

operate, remove it and make the necessary repairs.

**(2) ENGINE CRANKS, BUT WILL NOT START.**

The trouble probably lies in either the ignition system or the fuel system. The following test will determine which system is at fault.

Remove the ignition wire from one spark plug, and insert a piece of proper sized drill rod so it protrudes from the insulator. With the ignition on and the starter turning the engine over, hold the end of the rod approximately  $\frac{3}{16}$  inch from the block.

**CAUTION: On Fordomatic equipped trucks, make sure the selector lever is in “N.”**

If there is no spark or if there is a weak spark, follow steps “a” or “b” whichever is applicable. If there is a good spark, proceed with step “c.”

(a) **NO SPARK.** Follow the steps below to determine the cause and make the necessary repairs or replacements.

(1) Pull the coil wire from the top of the distributor. Hold the wire  $\frac{3}{16}$  inch from the cylinder head, and with the ignition on and the engine turning over, check for a spark.

**CAUTION: On Fordomatic equipped trucks, make sure the selector lever is in “N.”**

If a good spark is obtained, the trouble lies in either the distributor cap, rotor, or spark plug wires. Make sure these components are clean, dry, and not defective. Make repairs or replacements as necessary.

(2) If there was no spark in (1) clean the coil tower socket and replace the high tension wire between the coil and the distributor, then repeat the check. If a weak spark exists, the points are probably arcing. Test the condenser and replace it if necessary. Adjust the points. If a weak spark persists, test the coil and replace it if necessary.

(3) If there was no spark in (2), remove the distributor cap and see if the points are “breaking” and if an electrical spark occurs at the points. Adjust or replace the points as necessary. If there is a spark at the points, and they open properly, the secondary circuit of the coil is defective. If there is no spark at the points, install a “jumper” between the “Dist” terminal of the coil and the distributor, then check for a spark at the points. If there is a spark, replace the coil to distributor primary wire. If there is no spark, crank the engine until the points are closed, then install a “jumper” on one of the primary coil terminals and check for a spark at the other

terminal. Replace the coil if there is now a spark. If there is no spark, install a “jumper” between the battery and the distributor, then check for a spark at the ignition switch. If there is no spark, the ignition switch and distributor must be repaired

(b) **WEAK SPARK.** Perform the following checks in the order listed:

(1) Test the battery, then charge, or replace it as necessary.

(2) Remove the distributor cap, and check the condition of the points. Adjust, clean, or replace them as necessary. Severely pitted points usually indicate that the voltage regulator is improperly set or the condenser is faulty.

(3) Check the condition of the rotor, distributor cap, and plug wires. The wires must be clean, dry, and fully seated in the terminals. Replace any damaged or corroded wire.

(4) If the weak spark persists, test the coil and replace it if necessary.

(c) **GOOD SPARK.** If there is a good spark, perform the following fuel system checks in the order given.

(1) Check the fuel supply at the tank.

(2) Check to see if fuel is reaching the carburetor. Remove the air cleaner, and look down the carburetor throat while working the throttle by hand several times. Each time the throttle is actuated fuel should spurt from the accelerator pump discharge nozzle. If there is fuel at this point, the engine is probably flooded or there is water in the fuel system. If no fuel is observed at this point, disconnect the carburetor inlet line at the carburetor. Using a suitable container to catch the fuel, crank the engine to see if fuel is reaching the inlet fitting. If fuel is reaching the inlet fitting, the trouble is in the fuel pump or the fuel inlet line is clogged.

**NOTE: Check the flexible gas line for a collapsed condition.**

Remove the fuel tank filler cap, then disconnect the fuel pump inlet line at the pump. Blow air into the line to remove any obstructions. Connect the line and try to start the engine. If the engine does not start, check the fuel pump pressure, then repair or replace the pump as necessary.

(3) **ENGINE STARTS, BUT FAILS TO KEEP RUNNING.** Check the fuel system first. The ignition system sometimes can cause trouble, but it is usually after the engine has run for some time and is at operating temperature.

(a) Check the fuel supply at the tank.

(b) Try to start the engine. If the engine will operate with constant foot throttle, adjust the idle speed and check the choke adjustment.

If it will not operate with constant foot throttle, check the fuel system as outlined in (2) (c).

(c) If the fuel system is operating correctly and the engine still stalls, it may be due to the coil or condenser breaking down under operating temperature. Check these components and replace them as necessary.



**(4) ENGINE CONTINUALLY MISSES AT IDLE.** When the engine continually misses on the same cylinders, the fault generally lies in the ignition system.

(a) Isolate the miss by pulling one spark plug cable at a time from the plugs. Remove the plugs, then clean, inspect, and adjust them. Replace those that are badly fouled or burned.

(b) Check the spark plug wires for signs of deterioration and corrosion and replace them as necessary.

(c) Remove the distributor cap and rotor, then clean, inspect, and replace them as necessary.

(d) If the above steps do not correct the condition, check the compression to determine if it is satisfactory, and check the intake manifold for obstructions.

**(5) ENGINE MISSES ERRATICALLY AT IDLE.** A miss of this type may be caused by a combination of things. Check the following in sequence:

(a) Carburetor, including choke operation, idle mixture setting, and fuel level.

(b) The ignition system starting with the spark plugs.

(c) The vacuum lines and fittings for leaks.

(d) Valve operation. Perform a compression test if the miss persists. Repair the engine as necessary.

**(6) ENGINE MISFIRES OR HESITATES ON ACCELERATION.** This malfunction is usually a combination of faults in the ignition and fuel system, but also can be caused by the exhaust system. Perform the following checks in the sequence given:

(a) Check the operation of the exhaust gas control valve. If it is sticking, free it up or replace it as necessary.

(b) Check the paint on the intake manifold heat riser passage. If the paint is not burned off, the passage may be obstructed preventing the carburetor from properly vaporizing the fuel.

(c) Remove the spark plugs. Inspect, clean, and adjust the gap. Replace any plugs that are defective or lead fouled.

(d) Remove the distributor cap and check the point gap, distributor shaft clearance, condition of the cam lobes, and the points. Make the necessary repairs or replacements. Check the high tension wiring for signs of deterioration, and make repairs or replacements as necessary.

(e) Check the coil and condenser. Replace them if they are defective.

(f) Check the fuel pump pressure and adjust the carburetor fuel level. Check the accelerator pump action and linkage.

(g) If the problem still persists, perform a compression test and check the valve lash. Check the valve timing and assembled height. Make repairs or re-

be made. Make sure the throttle opens all the way, that the choke remains open, and that the governor cut-off operates properly. After preliminary checks are made, perform the following operations if the trouble has not been located.

(a) Check the compression. This will indicate whether the internal components are operating properly.

(b) If the compression checks within limits, check the ignition system, including initial timing and distributor operation.

(c) If the compression and the ignition system are satisfactory, check the fuel system, including carburetion and fuel pump pressure.

(d) If the problem still exists, a check of mechanical components must be made. Check the valve lash, cam lobe, lift, and valve timing. Make the necessary repairs.

## b. Fuel System.

The fuel system consists of the fuel tank, fuel pump, carburetor, and connecting lines. Dirt and other foreign material are a major source of fuel system problems. Keep all components as clean as possible.

**(1) EXCESSIVE FUEL CONSUMPTION.** Faulty carburetion is usually responsible for excessive fuel consumption. However, the following preliminary checks should be made.

Check for fuel leaks in the system. Check choke operation and adjustment, and make certain the accelerator linkage is free. Check to see if the brakes are dragging. Adjust the carburetor.

(a) Verify the complaint with test equipment installed in the truck. Show the customer how improper operation of the truck will affect fuel consumption.

(b) If the test shows fuel consumption to be excessive, rebuild the carburetor. Since poor carburetion is usually a combination of internal malfunctions, it is usually not advisable to try to repair only one system in the carburetor. Time will be saved by a complete carburetor overhaul.

**(2) CARBURETOR FLOODS.** Make a visual inspection of the carburetor for leaking gaskets or casting defects. Tap the carburetor bowl. If the flooding stops, the inlet needle was held open by foreign material. If the flooding persists, follow the steps below:

(a) Remove the air cleaner and check the choke operation.

(b) Check the fuel level, the condition of the carburetor float, and the fuel inlet needle and seat. Replace any defective parts.

(c) Check fuel pump pressure. If the pressure is excessive, the pump was forcing fuel past the float needle. Rebuild or replace the pump.

## c. Cooling System.

The cooling system is thermostatically controlled to

**BUY IT NOW!**  
Click Here To Order

DEVELOP FULL  
caused by poor  
y checks should

PayPal American Express Discover NOWUS MasterCard VISA

regulate engine operating temperature and provide for a short engine warm-up period.

(1) **ENGINE OVERHEATS.** Usually, engine overheating is the result of insufficient coolant supply. Check the coolant first. Make certain that the cause of trouble is not anti-freeze evaporation.

(a) If the supply is low, check for leaks in the cooling system, then make the necessary repairs.

(b) Check the water pump belt for proper tension and adjust it if it is loose.

(c) Inspect the radiator fins for obstructions (bugs, dirt, etc.). Clean it if it is clogged.

(d) Using a thermometer in the radiator, check the gauge reading for accuracy.

**NOTE:** *Inaccurate readings are sometimes caused by insufficient clearance between the head casting and the temperature sending unit element. Make repairs or replacements as necessary.*

(e) Check the thermostat for proper operation and heat range. If it is defective or of the wrong heat range,

replace it. Make sure the thermostat is correctly installed.

(f) Check the ignition timing and adjust it if necessary.

(g) Check the radiator for proper flow. Flush it if necessary.

(h) Remove the water pump and check for a defective impeller or a water passage obstruction. Make repairs or replacements as necessary.

(i) Check the cylinder head(s) for water passage obstructions. Clean out the passages or replace the head(s) if necessary.

(j) Check the cylinder block for water passage obstructions. Clean out the passages or replace the block if necessary.

(2) **ENGINE FAILS TO REACH NORMAL OPERATING TEMPERATURE.** Generally, this is caused by the thermostat sticking or being of the wrong heat range. Check the thermostat first. If the engine still does not reach operating temperature, check the gauge and sending unit with a thermometer installed in the radiator. Replace any defective parts.

## 2. TUNE-UP

Regular maintenance and inspection services are necessary for proper truck operation. In addition, to maintain satisfactory performance, a periodic engine tune-up should be made.

A reliable type of engine test equipment should be used to perform the tests outlined in the checking procedures. As the checks and tests are made, make a visual inspection of the wiring, vacuum hoses, cooling system hoses, heater hoses, etc.

### a. Minor Tune-Up.

Perform the following operations in the order given.

(1) **INSPECT IGNITION WIRES, BATTERY CABLES, AND CHECK THE CONDITION OF THE BATTERY.** Inspect all ignition wires for worn or damaged insulation. Make sure the wires are firmly seated in the distributor cap and that the terminals and the terminal sockets are free from corrosion.

Inspect the battery case for cracks and leaks. Make a battery capacity test. If unsatisfactory, make a battery charge test. If the charge is low, recharge the battery. Inspect the battery cable connections for corrosion, and clean them if necessary. Brush the cable connectors with wire brush to retard further corrosion, then tighten the con-

off. Remove all spark plugs.

Set the throttle in the wide open position and be sure the choke is wide open. Install a compression gauge in number 1 cylinder. Crank the engine until the gauge registers a maximum reading and record the reading. Note the number of compression strokes required to obtain this reading. Repeat the test on each cylinder, cranking the engine the same number of strokes as was required to obtain a maximum reading on number 1 cylinder.

A variation of  $\pm 10$  pounds from specified pressure is satisfactory. However, the compression of all cylinders should be uniform within 10 pounds.

A reading of more than 10 pounds above normal indicates carbon or lead deposits in the cylinder.

A reading of more than 10 pounds below normal indicates leakage at the head gasket, rings, or valves.

A low even compression in two adjacent cylinders indicates a head gasket leak. This should be checked before condemning the rings or valves.

To determine whether the rings or the valves are at fault, put a tablespoon of heavy oil on the piston, and repeat the compression test. The oil will temporarily seal leakage past the rings. If the same reading is obtained, the rings are satisfactory, but the valves are leaking. If the compression has increased 10 pounds or more over the original reading, it indicates there is leakage past the rings.



**BUY IT NOW!**

**Click Here To Order**



During a compression test, if the pressure fails to climb steadily and remains the same during the first two successive strokes, but climbs higher on the succeeding strokes, or fails to climb during the entire test, it indicates a sticky, or stuck valve.

(3) **CLEAN, ADJUST, AND INSTALL SPARK PLUGS.** Sandblast the spark plugs, wipe the porcelain clean, file the electrode tips flat, and adjust the spark gap. Test the plugs in an approved spark plug tester. Inspect the plugs for broken or chipped porcelain and badly burned electrodes. Replace all defective plugs. Install the spark plugs and tighten them to the specified torque.

(4) **CHECK THE DISTRIBUTOR.** Remove the distributor cap and rotor. Inspect the breaker points for pitting and burning. Replace defective points. Clean and install the distributor cap and rotor.

(5) **CHECK IGNITION TIMING.** Disconnect the distributor vacuum line. Operate the engine at idle speed. Check the timing with a timing light and make the necessary adjustments. Connect the distributor vacuum line.

(6) **CHECK MANIFOLD VACUUM AND ADJUST CARBURETOR IDLE.** Check the manifold vacuum at the specified idle speed.

If the vacuum is lower than specified, check for leakage at the vacuum lines and intake manifold. Check the carburetor idle adjustment.

If the vacuum is still below normal or is erratic, it is an indication of bad rings, sticky valves, weak valve springs, or a head gasket leak.

Set the engine idle speed and the carburetor idle fuel adjustment as outlined in Chapter IV.

(7) **CHECK GOVERNOR OPERATION—8-CYLINDER ENGINES.** Connect a tachometer to the engine. Start the engine and gradually increase the throttle opening, observing the tachometer reading, until the no-load cut-off speed is reached. If the cut-off is not within the specified range, stop the engine and make the necessary adjustments. Repeat the test until the correct cut-off speed is obtained.

(8) **CLEAN THE AIR CLEANER AND THE FUEL FILTER.** Clean the air cleaner, and oil the element. If the air cleaner is the oil bath-type, fill to the indicated level with engine oil of the specified viscosity.

Remove and clean the fuel pump bowl. Install a new filter element.

In addition, on the ECR 272, 302 and 332 cubic inch engines clean the fuel line filter container and replace element.

## b. Major Tune-Up.

Perform the following operations in the order given.

(1) **BATTERY.** Remove the cables from the battery. Clean the battery terminals and cable connectors. Inspect the battery case for cracks and leaks. Make a battery capacity test. If unsatisfactory, make a battery charge test. If the charge is low, recharge the battery. Replace deteriorated connectors and cables that have worn insulation. Brush the cable connectors with grease to retard further corrosion. Connect the cables to the battery.

(2) **CHECK THE GENERATOR AND REGULATOR.** Follow the procedures outlined in Part Three, "Electrical and Accessories."

(3) **TEST SPARK INTENSITY.** Determine if the spark from each spark plug wire will jump a  $\frac{3}{16}$ -inch gap, as follows:

Remove one spark plug wire, and install a terminal adapter in the wire terminal. Hold the end of the adapter approximately  $\frac{3}{16}$  inch from the cylinder head. Run the engine at idle speed. The spark should jump the gap regularly. Repeat the test on each lead.

If the spark is unsatisfactory at all spark plugs, trouble exists in the coil, condenser, rotor or cap, internally in the distributor, or in the external primary circuit.

If the spark is unsatisfactory at some, but not all of the spark plug wires, the trouble is in the wire itself, the wire is not seated in the housing socket, or the distributor cap is corroded.

(4) **TEST CYLINDER COMPRESSION.** Follow the procedure under "a. Minor Tune-Up."

(5) **CLEAN, ADJUST, AND INSTALL THE SPARK PLUGS.** Sandblast the spark plugs, wipe the porcelain clean, file the electrode tips flat, and adjust the gap. Test the plugs in an approved tester. Inspect the plugs for broken or chipped porcelain and badly burned electrodes. Replace all defective plugs. Install the plugs and tighten them to the specified torque.

(6) **CHECK MANIFOLD BOLT TORQUE.** Tighten the intake and exhaust manifold bolts and nuts to 23-38 foot-pounds torque.

(7) **TEST COIL AND CONDENSER.** If the spark intensity (3) is satisfactory, it will not be necessary to test the coil and condenser. However, if the spark is not satisfactory, test these parts on a test unit to determine which one is defective. Follow the instructions of the test unit manufacturer.

(8) **INSPECT BREAKER POINTS AND TEST THE DISTRIBUTOR.** Inspect the distributor points for pits, excessive metal transfer, and burned spots.

Test the vacuum advance and make adjustments, repairs, or replacements as required. Set the point gap to specifications. After setting the gap, check the point dwell. If the dwell angle is not to specifications, the dis-



**BUY IT NOW!**

**Click Here To Order**

**OF THE DRIVE**  
drive belts (fan, steering). Make



tributor cam is worn or the point assembly is defective. Replace all defective parts. Lubricate the distributor cam lightly with distributor cam lubricant.

(9) **CLEAN AND INSPECT THE DISTRIBUTOR CAP.** Inspect the cap for cracks or other damage. Remove all corrosion from the terminal housing sockets.

(10) **CHECK IGNITION TIMING.** Disconnect the vacuum line between the distributor and carburetor, and operate the engine at idle speed. Check the timing with a timing light and make the necessary adjustments. Connect the distributor vacuum line after completing the adjustment and check ignition advance as the engine is accelerated.

(11) **CHECK AND ADJUST VALVE LASH.** Check and adjust the valve lash after the engine is thoroughly warmed up.

(12) **TEST MANIFOLD VACUUM.** Check the manifold vacuum at the specified idle speed.

If the vacuum is lower than specified, check for leakage at the vacuum lines and intake manifold. Check the carburetor idle adjustment.

If the vacuum is still below normal or is erratic, it is an indication of bad rings, sticky valves, weak valve springs, or a leaking head gasket. If this condition exists it should be reported to the customer.

(13) **TEST FUEL PUMP PRESSURE AND CAPACITY.** The static pressure should be 3.5 - 5.5 p.s.i. at 500 r.p.m. (223 or 272 cubic inch engine) and 4.0 - 6.0 p.s.i. at 500 r.p.m. (302 or 332 cubic inch engine). The fuel pump capacity on the 223 or 272 cubic inch engine should be 1 pint in 30 seconds or less. The fuel pump capacity on the 302 or 332 cubic inch engine should be 1 pint in 20 seconds or less.

(14) **TEST BOOSTER PUMP VACUUM.** The booster pump vacuum should be 10.0 inches of mercury at 500 r.p.m. The vacuum should not drop rapidly when

the engine is stopped.

(15) **INSPECT AND CLEAN FUEL FILTER.** Remove and clean the fuel pump bowl. Install a new filter element.

In addition, on the ECR 272, 302, and 332 cubic inch engines, clean the fuel line filter container and replace the filter element.

(16) **CLEAN CARBURETOR.** Disassemble and clean the carburetor. Set the fuel level, and check the accelerator pump operation.

(17) **CLEAN AIR CLEANER.** Clean the air cleaner. Oil the element. If the air cleaner is the oil bath-type, fill to the indicated level with engine oil of the specified viscosity.

(18) **ADJUST CARBURETOR IDLE.** Set the engine idle speed and carburetor fuel adjustment as outlined in Chapter IV.

(19) **CHECK DEPOPPER OPERATION.** If the carburetor is equipped with a depopper valve, check the operation of the valve.

(20) **CHECK GOVERNOR OPERATION 272, 302, AND 332 CUBIC INCH ENGINES.** Follow the procedure under "a. Minor Tune-up."

(21) **EXHAUST ANALYSIS.** Make an exhaust gas analysis, following the instructions of the analyzer manufacturer.

(22) **CHECK THE DEFLECTION OF THE DRIVE BELTS.** Check the deflection of all drive belts (fan, generator, air compressor, and power steering). Make the necessary adjustments.

(23) **ROAD TEST.** Road test the truck as a final check on the work performed. Also, notice the performance of the transmission, axle, brakes, and any optional accessories. Recommend any additional service required when the truck is delivered to the owner.

### 3. ENGINE REMOVAL AND INSTALLATION

Engine removal and installation procedures are separated according to truck body styles. A separate procedure is given for Conventional and Cab Forward Trucks equipped with Fordomatic.

#### a. Conventional Truck and School Bus.

(1) **REMOVAL.** Remove the hood. Drain the cooling system and the crankcase. Remove the fan assembly and the fan belt. Disconnect the heater hoses at the engine. Remove the radiator and shroud assembly.

Remove the air cleaner, then tape the carburetor air horn closed.

Disconnect the windshield wiper vacuum hose at the manifold.

Disconnect the hand throttle control, choke cable, accelerator rod, and the accelerator retracting spring at the carburetor.

Disconnect the engine temperature sending unit wire, the oil pressure sending unit wire, the ignition coil primary wire, and the generator wires.

Disconnect the flexible fuel line at the fuel pump.

Disconnect the muffler inlet pipe at the exhaust manifold.

Disconnect the clutch release lever retracting spring. Disconnect the starter cable at the starter, then discon-

100% SATISFACTION GUARANTEED

**BUY IT NOW!**

Click Here To Order

PayPal American Express Discover MasterCard VISA

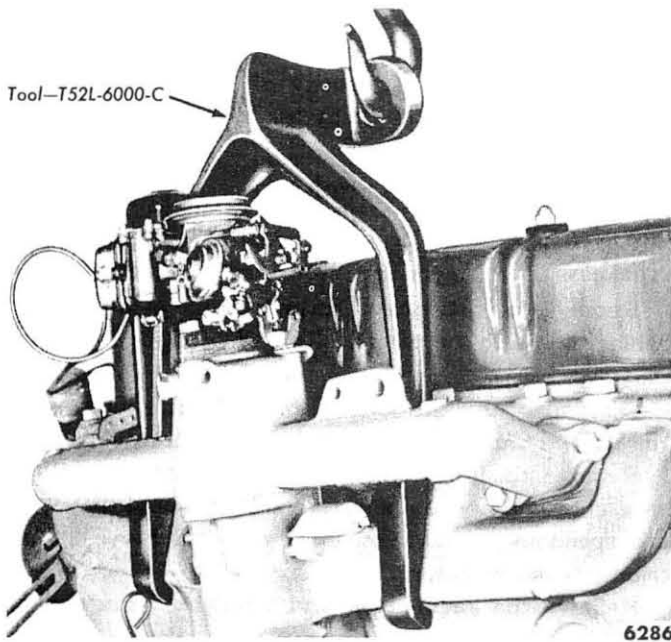

Fig. 1—6-Cylinder Engine Lifting Hook—Typical

nect the battery ground strap at the engine. Remove the starter assembly. Install the engine lifting hook (s) as shown in figs. 1 or 2.

Remove the clutch housing to engine bolts, then remove the housing lower cover.

Remove the engine front support bolts.

Take up the weight of the engine with a hoist. Support the transmission with a jack, then move the engine forward to separate the clutch from the transmission input shaft. Lift the engine carefully from the chassis.



6-Cylinder Engine

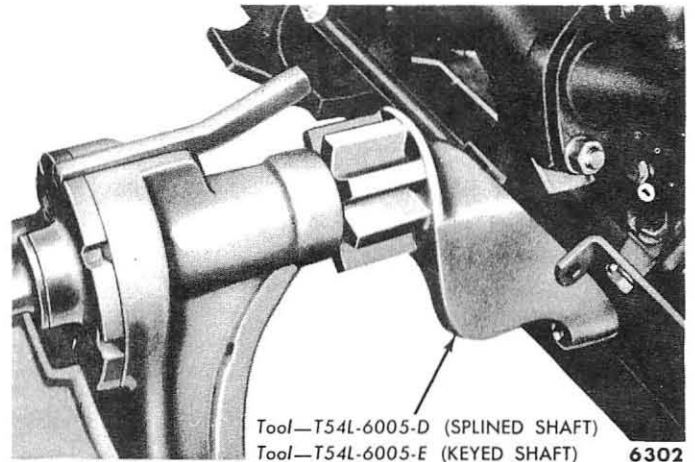

Fig. 3—Engine Mount—272 Cubic Inch Engine

Do not allow the engine to damage the front end sheet metal.

Install the engine on a work stand using the appropriate mount (figs. 3, 4, and 5).

**NOTE:** *On trucks equipped with a 302 or 332 cubic inch engine, lower the engine on blocks, then remove the right manifold. Install the engine lifting hooks, then raise the engine and install it on the work stand.*

(2) **INSTALLATION.** Install the engine lifting hook(s), take up the weight of the engine with a hoist, then remove the engine from the work stand.

**NOTE:** *On trucks equipped with a 302 or 332 cubic inch engine, remove the engine from the work stand and lower it on blocks. Install the right manifold. Install the engine lifting hooks.*

Install the engine in the chassis, aligning the transmission input shaft with the clutch disc and pilot bearing.

**NOTE:** *After the transmission input shaft enters the*

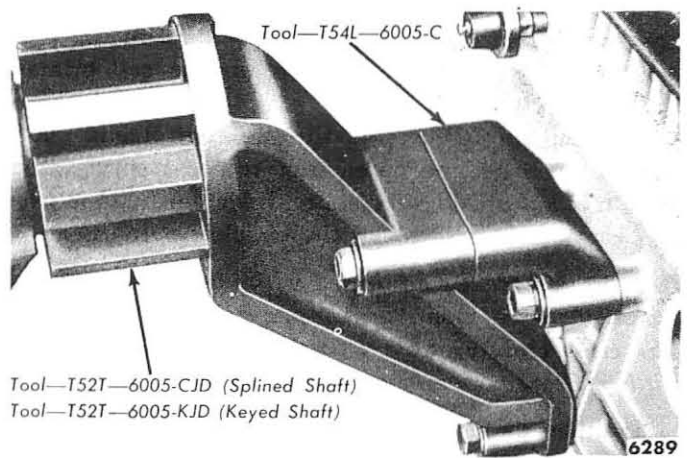

Fig. 4—Engine Mount Adapter—223 Cubic Inch Engine

**100% SATISFACTION GUARANTEED**

**BUY IT NOW!**

**Click Here To Order**

PayPal   American Express   Discover   MasterCard   VISA

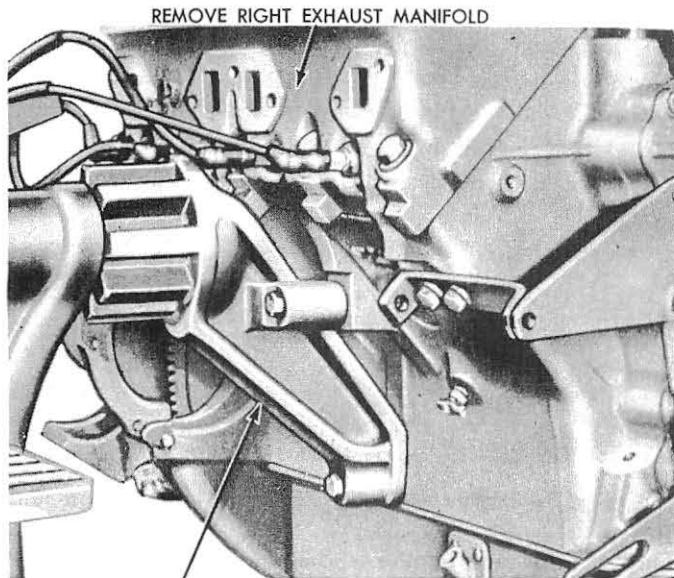

Fig. 5—Engine Mount—302 or 332 Cubic Inch Engine

clutch disc, it may be necessary to place the transmission in gear and rotate the crankshaft to align the clutch disc splines with the main drive gear splines.

Oil all mounting bolts before installation. Install the clutch housing to engine bolts, then tighten them to 45-50 foot-pounds torque. Install the housing lower cover, then tighten the bolts to 12-15 foot-pounds torque. Install the engine front support bolts. Tighten the  $\frac{7}{16}$  inch bolts to 45-50 foot-pounds torque and the  $\frac{9}{16}$  inch bolts to 85-95 foot-pounds torque. Remove the engine lifting hook(s).

Install the starter assembly and tighten the retaining bolts to 15-20 foot-pounds torque. Connect the starter cable and the ground strap. Connect the clutch release lever retracting spring.

Position the muffler inlet pipe on the manifold flange, install the lockwashers and nuts, then tighten the nuts to 23-28 foot-pounds torque.

Connect the fuel line. Connect the generator wires, the engine temperature sending unit wire, the oil pressure sending unit wire, and the ignition coil primary wire.

Connect and adjust the throttle control and choke control. Connect the accelerator rod and spring. Connect the windshield wiper hose. Remove the tape from the carburetor, and install the air cleaner.

**NOTE:** *On trucks equipped with an air compressor, vent the reservoir to compressor line, then install the retaining screw. Tighten the reservoir inlet*

belts, then adjust the tension of the belts. Install the hood. Fill the cooling system. Fill the crankcase with the proper grade and quantity of engine oil. Run the engine at fast idle and check for oil and coolant leaks.

## b. Cab Forward Truck.

(1) **REMOVAL.** Drain the cooling system and the crankcase. Disconnect the throttle return spring.

Remove the floor mat. Disconnect one of the battery cables to break the electrical circuit. Remove the floor pan.

Disconnect the ignition coil primary wire. Disconnect the ground wire at the coil mounting bracket.

Remove the screws securing the loom clip, taillight wire clip, and speedometer cable, then move the wires and speedometer cable out of the way. Remove the distributor cap and rotor.

Remove the air cleaner, and tape the carburetor air horn closed.

Remove the radiator and front end sheet metal assembly as outlined in *Part Four, Chapter III*.

Disconnect the hand throttle control and the choke control. Disconnect the accelerator linkage. Remove the windshield wiper hose from the intake manifold (or vacuum pump inlet). Remove the fan assembly and drive belts.

**NOTE:** *On trucks equipped with an air compressor, vent the air compressor drain cock. Remove the air compressor. Remove the clip retaining the air line to the front end of the right cylinder bank, loosen the fitting at the reservoir end of the line, then lay the line back against the engine side compartment.*

Remove the temperature sending unit wire, and the generator wires. Remove the oil level indicator tube. Remove the engine front support nuts and washers. Disconnect the flexible fuel line at the fuel pump. Close off the main fuel line to prevent loss of fuel.

Disconnect the muffler inlet pipe, and pull it away from the manifold flange. Remove the clutch housing lower cover. Remove the clutch housing to engine retaining bolts. Disconnect the starter cable and the battery ground strap. Remove the starter.

Install the engine lifting hooks as shown in fig. 2. Position a floor jack under the engine, and place a wood block between the jack and the oil pan. Raise the engine slightly, and remove the front support bolts and rubber pad. Raise the engine carefully with a hoist, move it forward to clear the transmission input shaft, and remove it from the chassis. Mount the engine on a work stand using the appropriate adapter.

**NOTE:** *On trucks equipped with a 302 or 332 cubic inch engine, lower the engine on blocks, then remove the right manifold. Install the engine mount adapter.*

**100% SATISFACTION GUARANTEED**

**BUY IT NOW!**

**Click Here To Order**

PayPal   American Express   Discover   MasterCard   VISA

*Install the engine lifting hooks, then raise the engine and install it on the work stand.*

(2) **INSTALLATION.** Install the engine lifting hooks, take up the weight of the engine with a hoist, then remove the engine from the work stand.

**NOTE:** *On trucks equipped with a 302 or 332 cubic inch engine, remove the engine from the work stand and lower it on blocks. Install the right manifold. Install the engine lifting hooks.*

Lower the engine carefully into the engine compartment until it rests on the floor jack. Align the clutch disc and pilot bearing with the transmission input shaft, then slide the engine in until it contacts the clutch housing.

**NOTE:** *After the transmission input shaft enters the clutch disc, it may be necessary to place the transmission in gear and rotate the crankshaft to align the clutch disc splines with the main drive gear splines.*

Lower the engine on the front support and install the washers and bolts. Tighten the  $\frac{7}{16}$  inch bolts to 45-50 foot-pounds torque and the  $\frac{9}{16}$  inch bolts to 85-95 foot-pounds torque. Remove the engine lifting hooks.

Install the clutch housing to engine bolts, then tighten them to 45-50 foot-pounds torque. Install the housing lower cover, then tighten the bolts to 12-15 foot-pounds torque. Install the starter assembly and tighten the retaining bolts to 15-20 foot-pounds torque. Connect the starter cable and the battery cable.

Position a new gasket and the muffler inlet pipe on the manifold. Install the lockwashers and nuts, then tighten the nuts to 23-28 foot-pounds torque.

Connect the engine temperature sending unit wire, the oil pressure sending unit wire, and the generator wire. Install the oil level indicator tube.

Connect the accelerator linkage. Connect and adjust the choke and throttle controls, then connect the windshield wiper vacuum hose. Connect the flexible fuel line.

**NOTE:** *On trucks equipped with an air compressor, install the compressor, connect the compressor lines, and install the air line clip retaining screw. Tighten the reservoir inlet fitting. Close the reservoir drain cock.*

Install the drive belts and fan assembly. Install the radiator and front end sheet metal assembly as outlined in Part Four, Chapter III.

Remove the tape from the carburetor, and install the

and the ground wire clip, and retaining screws. In-

Install the floor pan. Connect the battery cable, install the cover, then install the floor mat. Connect the throttle return spring.

Fill the cooling system. Fill the crankcase with the proper grade and quantity of engine oil. Run the engine at fast idle and check for oil or coolant leaks.

### c. Fordomatic—Conventional and Cab Forward Trucks.

The following procedure covers trucks equipped with Fordomatic (except Parcel Delivery).

(1) **REMOVAL.** To remove the engine from Fordomatic equipped trucks, perform the steps outlined for the appropriate truck in the preceding paragraphs, in addition to the following steps:

Disconnect the transmission oil to water cooler inlet and outlet tubes (if so equipped).

Remove the upper bolts retaining the converter housing to the engine. Remove the converter housing to engine lower bolts. Remove the converter housing lower access cover, then turn the flywheel till the flywheel drive plate is in position so that the three bolts can be removed. Turn the flywheel 180°, and remove the other three bolts.

Install the engine lifting hook(s), then remove the engine in the usual manner.

(2) **INSTALLATION.** Install the engine in the chassis in the usual manner, aligning the converter pilot with the crankshaft. Lower the engine on the front supports. Install the converter housing to engine upper bolts. Tighten the bolts finger tight. Install the front support washers and nuts. Remove the engine lifting hook(s).

Install the converter housing to engine lower bolts, then tighten the bolts to 40-45 foot-pounds torque. Install the six converter to flywheel drive plate bolts. Install the converter housing lower access cover.

Tighten the converter housing to engine upper bolts to 40-45 foot-pounds torque. Install the floor pan and the floor mat.

Connect the transmission oil to water cooler inlet and outlet tubes (if so equipped).

Proceed with the remainder of the engine installation in the manner prescribed for the individual truck.

### d. Parcel Delivery Trucks.

The following procedure applies to all parcel delivery trucks. The engine and transmission are removed as an assembly.

(1) **REMOVAL.** Remove the driver's seat and support. Drain the crankcase. Disconnect the air cleaner tube and elbow from the engine cover bracket. Tape the carburetor air horn closed. Drain the cooling system. Remove the clutch pedal plate. Remove the brake pedal pad, then remove the pedal opening plate and slide it



over the brake pedal rod. Remove the rubber mat from the pedal opening. Remove the two screws retaining the dimmer switch, and drop the switch through the floor board. Disconnect the accelerator rod from the pedal. Remove the left floor plate (the accelerator pedal and engine front cover hood lock are removed with the floor plate). Remove the master brake cylinder inspection cover. Remove the ten screws from the engine cover base plate. Remove the nuts and bolts retaining the center floor plate to the engine cover base plate. Loosen the three bolts securing the cross member reinforcing plate to the left and right wheel housings.

**NOTE:** *Drive a wedge between the reinforcing plate and the left and right wheel housing.*

Remove the center floor plate, then remove one reinforcing plate to cross member bolt from each end of the body cross member. Remove the engine cover and base plate assembly.

Disconnect the windshield wiper vacuum line at the fuel pump, and the fuel flex line at the tank fuel line.

**NOTE:** *On Fordomatic equipped trucks disconnect the transmission selector rods at the transmission.*

Disconnect the radiator lower and upper hoses at the radiator. Disconnect the radiator to cylinder outlet tube and hose at the water pump. Disconnect the primary wire from the coil and the ground wire at the coil bracket. Disconnect the heat indicator and oil pressure indicator wires. Disconnect the starter cable at the solenoid and the starter ground strap at the starter. Disconnect the exhaust inlet pipe at the exhaust manifold. Remove the emergency brake cable clevis pin, then remove the emergency brake holding bracket. Push the emergency brake cable assembly out of the way. Remove the speedometer cable holding bracket, then remove the speedometer cable from the transmission speedometer gear and move the assembly out of the way.

Remove the fan assembly and belt. Disconnect the generator wires. Remove the body cross member. Disconnect the choke cable at the carburetor.

Remove the engine front support bolts. Remove the rear support mount bolts and the lower right and left pads.

Remove the universal joint "U" bolts and drop the rear of the drive shaft. Disconnect the universal joint knuckle dust cap. Remove the drive shaft spline from the universal joint knuckle and plug assembly.

Remove the carburetor inlet fitting and fuel line from the carburetor.

Remove the rocker arm cover, then install the engine front cover. Position the engine in the truck through the right door. Connect the exhaust outlet pipe as the engine is lowered into position.

(2) **INSTALLATION.** Attach the engine lifting hook. Install the bolts in the engine block mounting holes. Position the engine in the truck through the right door.

**NOTE:** *Position the engine through the door transmission first. Connect the exhaust outlet pipe as the engine is lowered into position.*

Install the rear mount pads and bolts.

**NOTE:** *Keep the engine hoist attached to the engine so the transmission will rest lightly on the cross member. Line up the holes and install the bolts.*

Install the engine front support bolts, then lower the engine on the mounts and tighten the support bolts. Remove the engine lifting hook. Install the rocker arm cover. Install the carburetor inlet line and fitting.

Install the drive shaft spline in the universal joint knuckle and plug assembly. Connect and tighten the universal joint knuckle dust cap and seal. Connect the drive shaft and "U" bolts to the rear universal joint.

Connect the choke cable and generator wires. Install the fan assembly and belt. Install the speedometer cable and emergency brake cable and bracket. Connect the exhaust inlet pipe, the starter cable, heat indicator wires, oil pressure indicator wires, engine ground wires, and coil primary wire. Connect the radiator to cylinder outlet tube and hose, and the radiator lower and upper hoses. Connect the fuel flexible line and windshield wiper vacuum line.

**NOTE:** *On Fordomatic equipped trucks, connect the transmission selector rods.*

Fill the crankcase with the proper grade and quantity of engine oil. Position the body cross member, then install the cross member bolts. Position the engine cover and base plate. Install the cross member to reinforcing plate lower bolts. Position the floor panel, then install the bolts securing the floor panel to engine cover base plate. Install the floor panel screws. Install the bolts securing the cross member support to the right and left wheel housing. Install the engine cover base plate screws. Install the sheet metal cover between the engine cover and dash panel. Install the master brake cylinder inspection plate.

Install the left floor plate. Connect the accelerator rod and dimmer switch. Position the rubber mat over the brake pedal opening, then install the pedal opening plate and pad.

Install the air cleaner to engine cover bracket, then install the air cleaner and tube. Install the operator's seat and bracket.

Fill the radiator. Run the engine at fast idle and check for oil and coolant leaks.



## 4. INTAKE AND EXHAUST MANIFOLDS

### a. Cleaning and Inspection.

Wash grease, oil, and dirt from the outside of the manifold. Clean the mating surfaces and check them for damage. Repair or replace the manifolds as necessary.

On the intake manifolds, check the fuel-air passages and the heat riser passages for foreign material. Inspect the surfaces for cracks or other visible defects. Repair or replace the manifolds as necessary.

**CAUTION:** Remove all filings and foreign matter that may have entered the manifolds as a result of repair work.

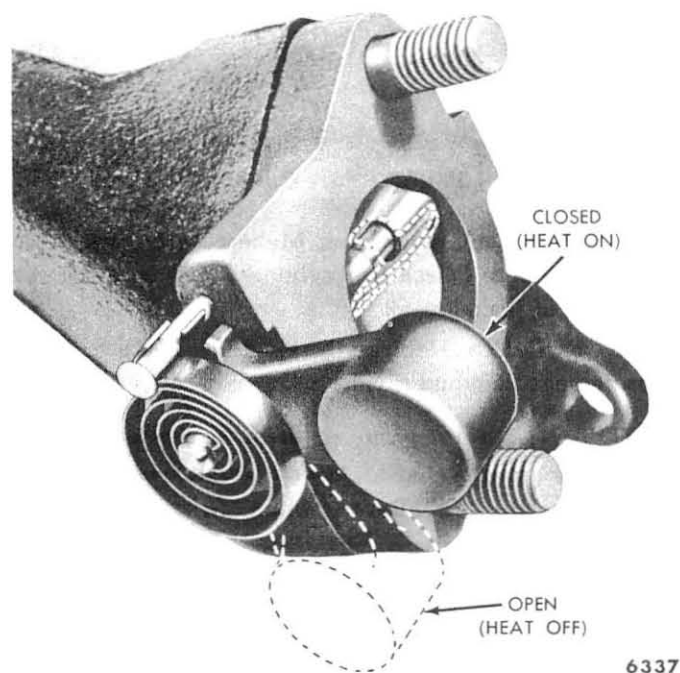

Fig. 6—Exhaust Control Valve—ECW-Y 272 Cubic Inch Engine

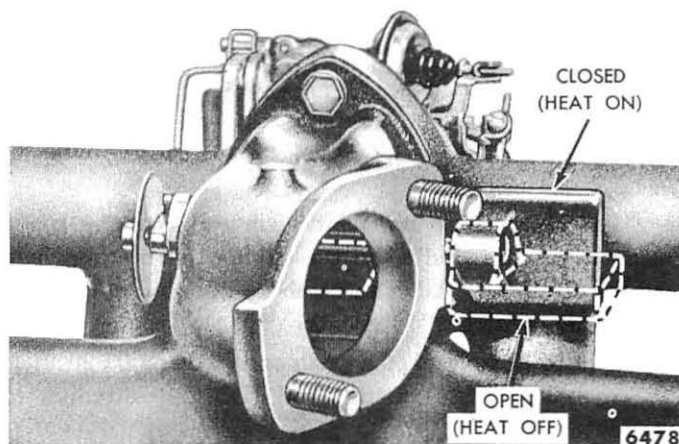

Fig. 7—Exhaust Control Valve—6-Cylinder Engine

### b. Exhaust Gas Control Valve—223 and ECW-Y 272 Cubic Inch Engines.

Check the valve spring to make sure it is hooked on the stop pin. The spring stop is at the top of the valve housing when the valve is properly installed. The action of the valve is illustrated in figs. 6 and 7.

Check to make sure the spring holds the valve closed when the engine is cold. Actuate the counterweight by hand to make sure it moves freely through approximately 90° of rotation without binding.

The valve is closed when the engine is at normal operating temperature and running at idle speed. However, a properly operating valve will open when very light finger pressure is applied to the counterweight. Rapidly accelerate the engine to make sure the valve momentarily opens. The valve is designed to open when the engine is at normal operating temperature and is operated at high r.p.m. Free stuck valves with a penetrating oil, or kerosene and graphite mixture.

## 5. ROCKER MECHANISM, CYLINDER HEADS, VALVES, VALVE LASH ADJUSTMENT, AND VALVE TIMING

The section covers the inspection and repair procedures applicable to the rocker mechanism, cylinder head, and valves. In addition, the methods used to adjust the valve lash and to check valve timing are given.

of the rocker arm bore and the O. D. of the rocker arm shaft, at the location of the rocker arms. Inspect the rocker arms for grooved pads. Check the rocker adjusting screws and lock nuts for stripped or broken threads, and the ball end of the screw for nicks, scratches, or excessive wear.

Inspect the locating springs for cracks or other signs of failure.

Inspect the oil drain tube for cracks or sharp bends. Check the ball and socket ends of the push rods for nicks, grooves, roughness, or excessive wear.

**100% SATISFACTION GUARANTEED**

**BUY IT NOW!**

**Click Here To Order**

individually re-  
v. Check the I.D.

PayPal American Express Discover NOWUS MasterCard VISA

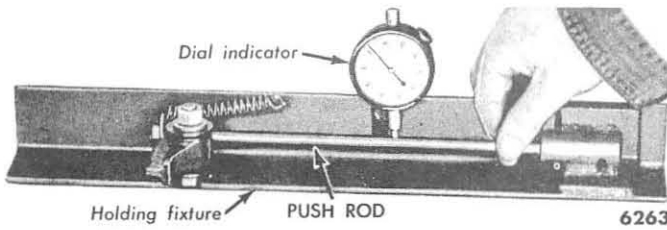

Fig. 8—Push Rod Runout Check

A suitable check for bent push rods can be made while they are installed in the engine by rotating them (valve closed) or they can be checked between ball and cup centers with a dial indicator (fig. 8).

If the total runout of a push rod exceeds 0.020 inch, at any point, discard the rod. Do not attempt to straighten.

(2) **REPAIRS.** If the clearance between the shaft and rocker arms is excessive, replace the shaft and/or the rocker arms. Replace all rocker arms that have severely scored or scuffed bores and/or grooved pads. Replace all severely scored or scuffed rocker shafts. Dress up minor nicks or scratches. Replace all damaged adjusting screws, lock nuts, and springs.

Replace the oil drain tube if it is cracked or has a sharp bend.

### b. Cylinder Heads.

To protect the machined surfaces of the cylinder heads, do not remove the holding fixture while the heads are off the engine.

(1) **CLEANING AND INSPECTION.** With the valves installed to protect the valve seats, remove carbon deposits from the combustion chamber and valve heads with a scraper and a wire brush. Be careful not to scratch the gasket surface. Clean the heads with solvent to remove old gasket sealer, dirt, and grease.

Check the head for cracks. Check the gasket surface for burrs, nicks, and for flatness (fig. 9). Service specifications for flatness are 0.006 inch maximum overall, or



face Flatness

**100% SATISFACTION GUARANTEED**

**BUY IT NOW!**

**Click Here To Order**

PayPal | American Express | Discover | MasterCard | VISA

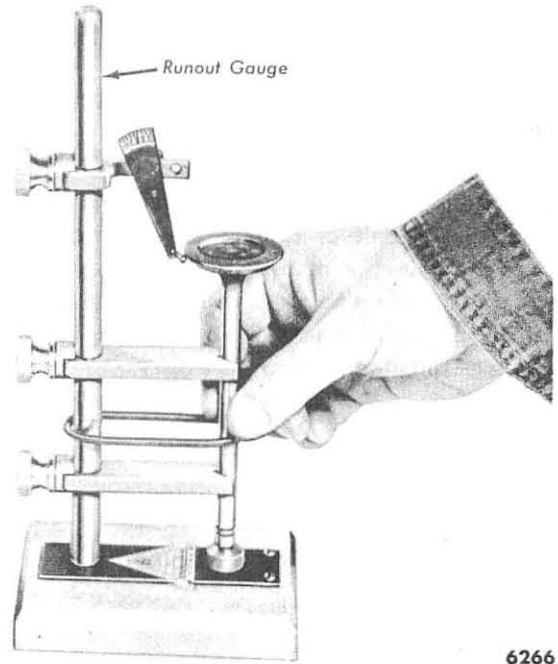

Fig. 10—Valve Face Runout Check

0.003 inch in any six inches. Make sure all water passages are open. Check the cylinder head core plug for evidence of leakage.

(2) **REPAIRS.** Replace the head if it is cracked, or if it is damaged beyond repair.

**CAUTION: Do not plane or grind excessive material from the cylinder head gasket surface as the compression ratio is altered when this operation is performed.**

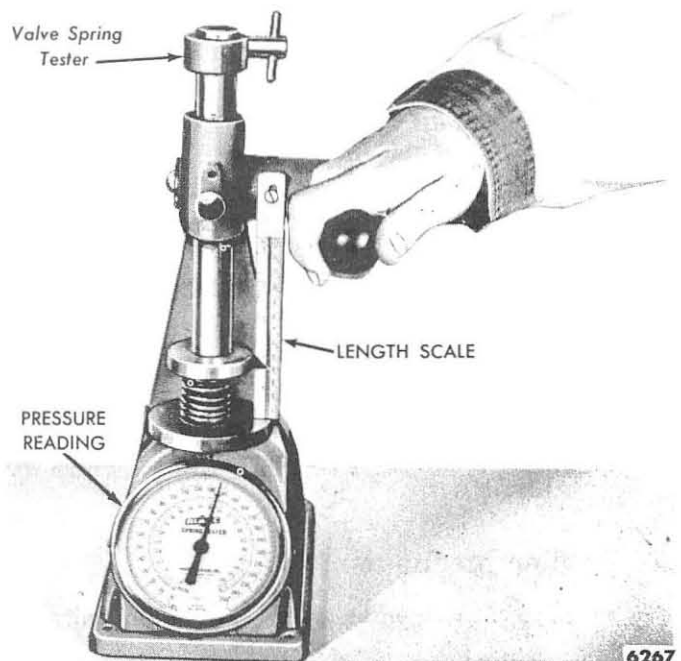

Fig. 11—Valve Spring Pressure Check

Table 1—Valve Types

Engine (Cubic Inch)	Umbrella Seals		Rotating Valves		Free Turning Valves Exh.	Sodium Cooled Exhaust Valves
	Int.	Exh.	Int.	Exh.		
EBR-S, -T 223	Yes	Yes	Yes	Yes	No	No
ECW-Y 272	Yes	Yes	Yes	Yes	No	No
ECR 272	Yes	No	Yes	No	Yes	Yes
ECS 302	Yes	No	Yes	No	Yes	Yes
ECT 332	Yes	No	Yes	No	Yes	Yes

Remove all burrs or scratches with an oil stone.

Replace the core plug if it shows signs of leakage.

(3) **SPARK PLUG HOLE ADAPTERS.** If it is desired to use standard 14 millimeter spark plugs, an adapter is available which reduces the 18 millimeter hole to 14 millimeters. The adapter installation procedure is as follows:

Position a spark plug gasket on a standard 14 millimeter plug and install the plug in an adapter. Insert the spark plug and adapter assembly into the 18 millimeter hole and tighten the plug to 25-30 foot-pounds torque. This torque is sufficient to seal the adapter in place and it will not back out when the spark plug is removed. Once the adapters are installed, standard 14 millimeter spark plug gap and torque specifications apply.

### c. Valve Mechanism.



The two types of valve assemblies used in the truck engines are the rotating-type and the free-turning-type. Table 1 lists the valve types peculiar to each engine.

Valve guides are made integral with the cylinder heads. Valves with oversized stems are available as replacements if it is necessary to ream the valve guides.

The ECR 272, 302, and 332 cubic inch engines have sodium cooled exhaust valves.

(1) **CLEANING AND INSPECTION.** Discard umbrella-type valve stem seals, and replace with new seals. Scrape and/or wire brush carbon from the head and stem of the valves and from the inside of the guides. Remove varnish from the valve stems. Carefully clean all carbon from the valve seat with a fine wire brush.

Check the valve for evidence of imperfect seating, heavy discoloration, burning or erosion, or evidence of warpage. Check the valve face runout (fig. 10), and also check the face for pits and grooves. Inspect the ends of the valve stem and cap for grooves or scores.

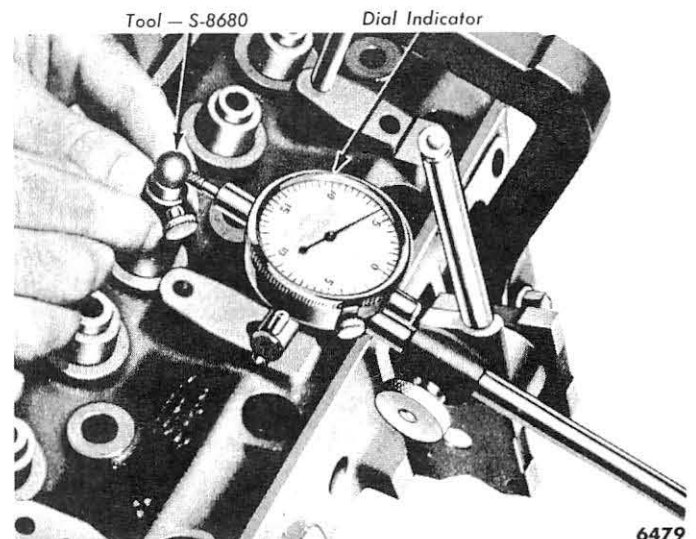

Fig. 13—Valve Stem Clearance Check—Typical

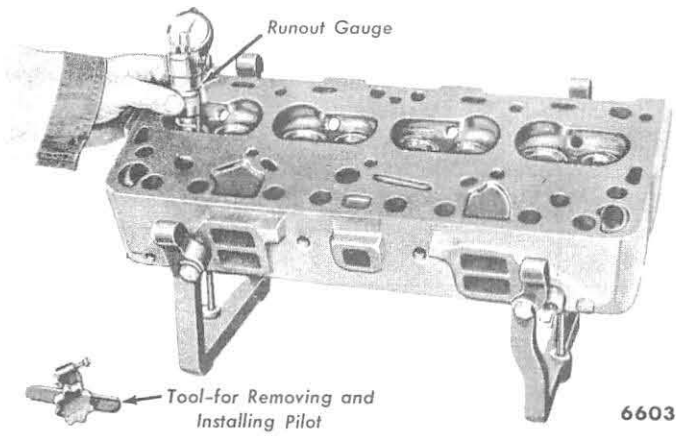

Fig. 14—Valve Seat Runout Check—Typical

Inspect the valve springs for signs of failure. Check the valve spring for proper pressure (fig. 11) and squareness (fig. 12).

Check the valve spring retainers, locks, and sleeves for wear or signs of failure.

Check the exhaust valve seat insert for signs of excessive wear (ECR 272, 302, and 332 cubic inch engines).

Check the valve stem clearance of each valve in its respective valve guide as shown in fig. 13. Install the tool on the valve stem until fully seated and tighten the set screw, then permit the valve to drop away from its seat until the tool contacts the upper surface of the valve guide. Position a dial indicator with a flat tip against the center portion of the spherical section of the tool at approximately 90° to the valve stem. Move the tool back and forth on a plane that parallels normal rocker action and take the indicator reading without lifting the tool from the valve guide upper surfaces. Divide the indicator reading by 2 (division factor of the tool) to obtain the actual stem clearance.

Check the valve seat runout and the valve seat width as shown in figs. 14 and 15.

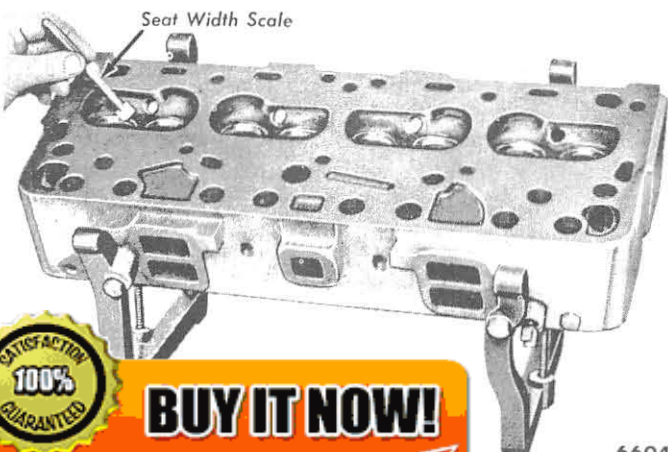

Fig. 15—Valve Seat Width Check—Typical

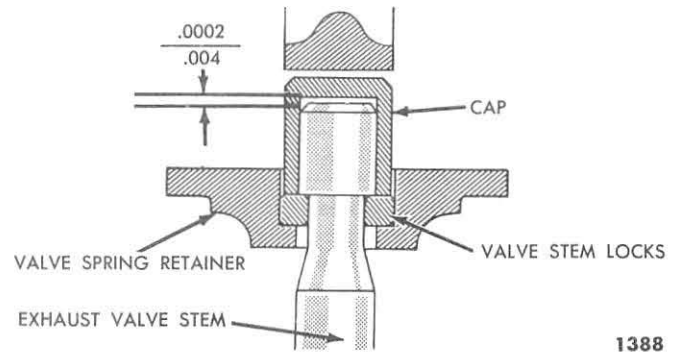

Fig. 16—Valve Clearance—Free Turning Valve

(2) **REPAIRS.** Discard any defective valves, springs, locks, retainers, or sleeves.

**CAUTION:** Do not discard sodium cooled valves with other scrap metal in scrap bins.

If a sodium cooled valve is accidentally broken and the sodium exposed, it will react violently upon contact with water resulting in fire and explosion due to chemical action. Therefore, these valves should be handled with care and disposed of by being buried in the ground in an area not subjected to excavation, or dropped into deep natural water in a section not subjected to dredging.

(a) **REFACING VALVES.** If the valve face runout is excessive, grind the valve face at a 45° angle on a precision valve grinder. Follow the instructions of the equipment manufacturer. Grind off only enough stock to remove pits and grooves. If the edge of the valve head is less than 1/32 inch thick after grinding, replace the valve. If the runout still exceeds specifications after grinding, check the equipment used in the grinding operation.

Grind all grooves or score marks from the end of the valve stem. On the rotating-type valve assembly, do not remove more than 0.010 inch from the stem.

The free turning-type valve design requires a clearance of 0.0002-0.004 inch between the end of the valve stem and the inside of the cap (fig. 16), so the cap can carry the valve spring pressure permitting the valve to rotate. The clearance can be measured before the valve is installed with a micro gage (Tool—SE1726), as shown in fig. 17. If the clearance is less than 0.0002 inch, grind off the end of the valve stem to provide the proper clearance. If the clearance is greater than 0.004 inch, reduce the clearance by lapping the open end of the

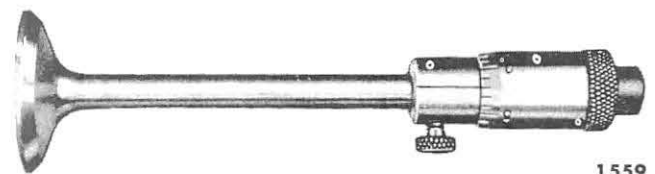

Fig. 17—Measuring Valve to Cap Clearance—Free Turning Valve

**100% SATISFACTION GUARANTEED**

**BUY IT NOW!**

**Click Here To Order**

PayPal, American Express, Discover, MasterCard, VISA

6604

1559

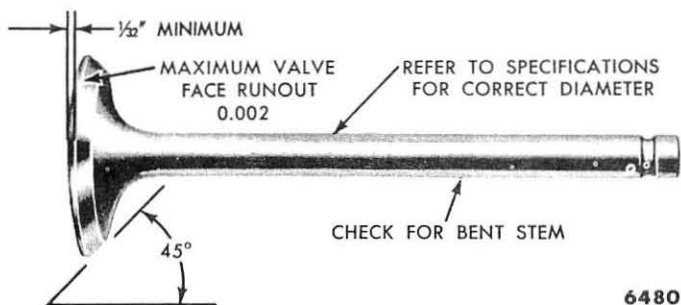

Fig. 18—Critical Valve Tolerances—Typical

cap on a smooth surface.

The critical tolerances of the valve are illustrated in fig. 18.

(b) **REFACING VALVE SEATS.** Grind the valve seat (fig. 19) to a true 45° angle. Remove only enough stock to clean up pits or grooves. If the valve seat width exceeds specifications, remove just enough stock from the top and/or bottom edge of the seat to reduce the width to specifications. Use a 30° angle wheel to remove stock from the bottom of the seat and a 60° angle wheel to remove stock from the top (fig. 20 or 21). Keep the seat as near to the center of the valve face as possible. Place Prussian Blue on the valve seat and install the valve to check the point of contact.

After refacing valves and seats, it is good practice to lightly lap in the valves with a medium grade lapping compound to match the seats.

(c) **VALVE SEAT INSERT REPLACEMENT.** To remove the exhaust valve insert from the ECR 272, 302 or the 332 cubic inch engine, invert the head and insert a drift through the exhaust valve port, then drive the

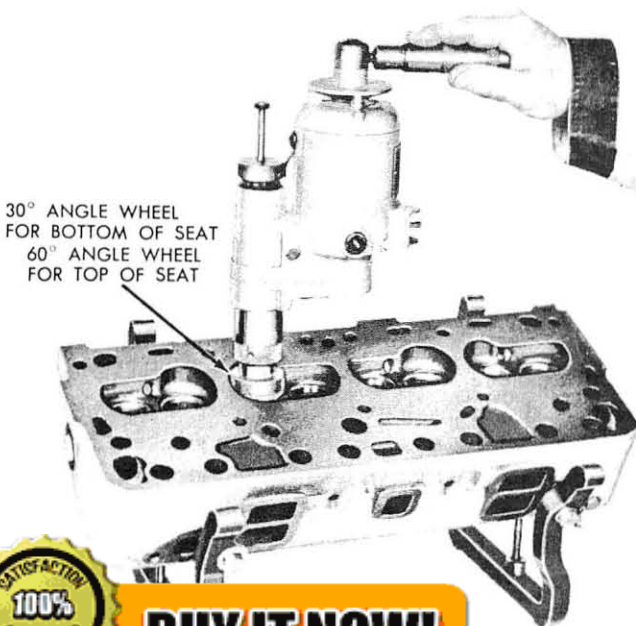

30° ANGLE WHEEL FOR BOTTOM OF SEAT  
60° ANGLE WHEEL FOR TOP OF SEAT

6605

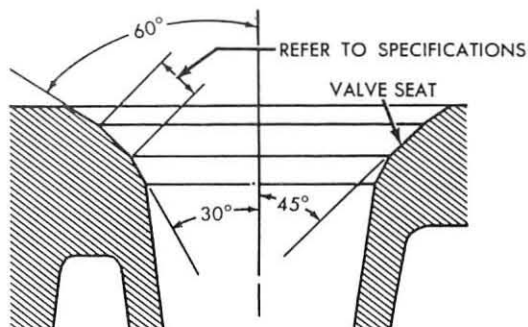

Fig. 20—Valve Seat Width—Typical

6292

seat out.

Counterbore the insert recess to specifications in the manner shown in fig. 22. Cut slightly (0.001-0.002 inch) below the old counterbore depth to clean up this face. Clean out chips and all oil from the recess.

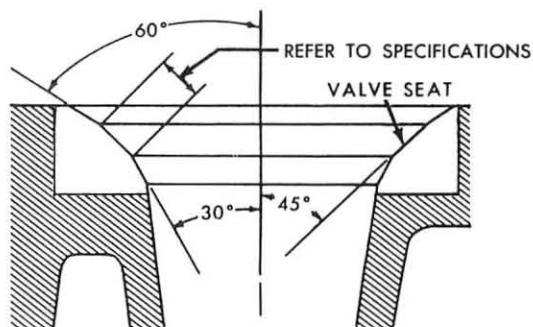

Fig. 21—Exhaust Valve Seat Width—Insert-Type Seat Shown

6293

Chill the oversize insert and the installation tool in dry ice for 1/2 hour. Position the insert on the tool with the small radius on the outer edge facing outward. Pilot the driving tool in the valve guide, then drive the insert into the counterbore until it is fully seated. Do not peen the area around the insert. Reface the new valve seat insert.

**CAUTION:** The installation of the insert must be performed immediately upon removal of the tool and insert from the dry ice. Protect the hands with gloves when handling the chilled insert and tool.

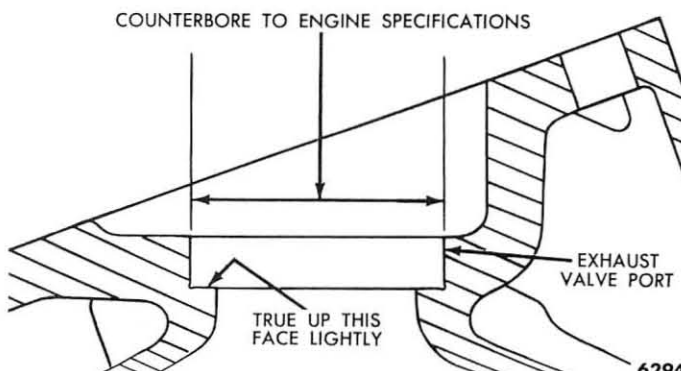

Fig. 22—Counterbore for Oversize Insert

6294

**100% SATISFACTION GUARANTEED**

**BUY IT NOW!**

**Click Here To Order**

PayPal, American Express, Discover, MasterCard, VISA

Typical

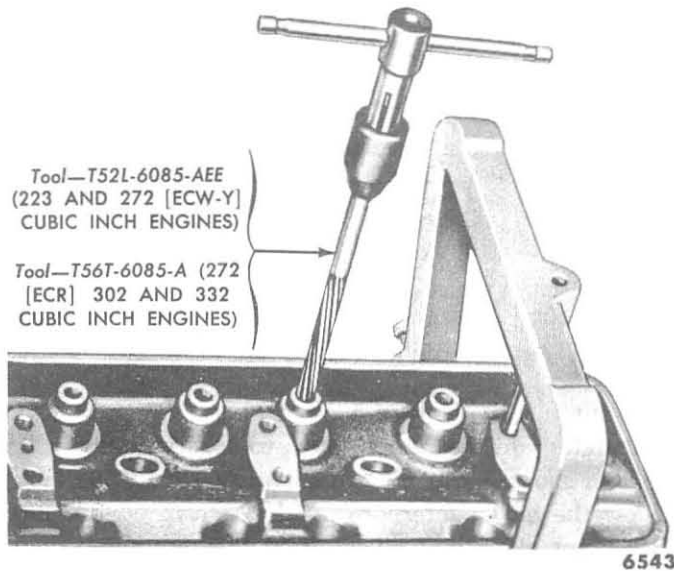
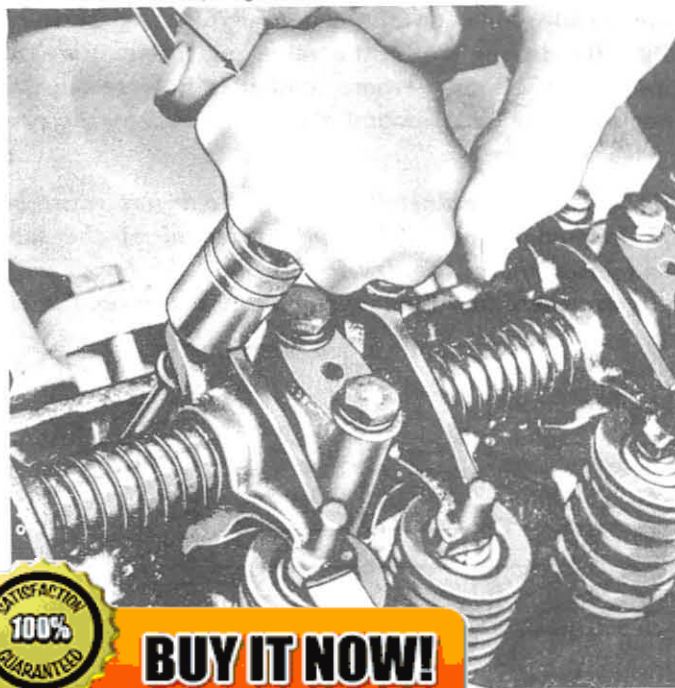

Fig. 23—Reaming Valve Guides—Typical

(d) **SELECT FITTING VALVES.** Oversize valves with a stem diameter of 0.003, 0.015, and 0.030 inch are available for service. Occasionally the 0.003 inch oversize valve is used in production in one or more positions.

If the valve stem clearance is excessive and the diameter of the valve stem is on the lower limit (as determined by measuring the valve stem with a micrometer), select a new valve with a stem diameter on the upper limit. If in the use of standard valves the clearance cannot be reduced to a satisfactory limit, ream the valve guide (fig. 23) for the next oversize valve stem.

Combination Adjusting Tool



—Typical

Table 2—Valve Lash Specifications

Engine (Cu. In.)	Preliminary (Cold)		Final (Hot)	
	INT.	EXH.	INT.	EXH.
223	0.019	0.019	0.019	0.019
272	0.018	0.018	0.018	0.018
302	0.007	0.023	0.009	0.021
332	0.007	0.023	0.009	0.021

#### d. Valve Lash Adjustment.

Reference is made in the procedures for a preliminary (cold) valve lash adjustment to placing number 1 piston on top dead center (T.D.C.) at the end of the compression stroke. Number 1 piston is on T.D.C. at the end of the compression stroke when both valves are closed and the timing mark on the crankshaft damper is in line with the timing pointer.

Step-type feeler gauges (“go” and “no go”) can be used to obtain the proper clearance (fig. 24).

Valve lash is adjusted by means of the set screw and lock nut located on the push rod end of the rocker arm.

It is very important that the valve lash of all valves be held as close as possible to the correct specifications (Table 2). If the valve lash is set too low, rough engine idle and poor engine performance can result. If the valve lash is excessive, valve action noise will result, and engine performance will be affected.

If the cylinder head or the rocker mechanism has been removed and installed, it will be necessary to make a preliminary adjustment before starting the engine. If the valve lash adjustment is made for the purpose of engine tune-up, omit step (a) and proceed with step (b) under the procedure for the applicable engine.

(1) **6-CYLINDER ENGINE.** Remove the rocker arm cover.

(a) **PRELIMINARY ADJUSTMENT.** Make two chalk marks on the crankshaft damper. Space the marks approximately 120° apart so that with the timing mark, the damper is divided into three equal parts (120° represents 1/3 of the distance around the damper circumference).

Rotate the crankshaft until number 1 piston is near T.D.C. at the end of the compression stroke. Adjust the intake and exhaust valve lash for number 1 cylinder.

Repeat this procedure for the remaining sets of valves, turning the crankshaft 1/3 turn at a time, in the direction of rotation, while adjusting the valves in the firing order sequence (1-5-3-6-2-4).

(b) **FINAL ADJUSTMENT.** Run the engine for a minimum of 30 minutes at approximately 1200 r.p.m. in order to stabilize engine temperatures. With the engine

**100% SATISFACTION GUARANTEED**

**BUY IT NOW!**

**Click Here To Order**

PayPal   American Express   Discover   MasterCard   VISA

idling, check the valve lash. Adjust the lash, if necessary (fig. 24). Install the rocker arm cover.

(2) **8-CYLINDER ENGINES.** Remove the rocker arm covers.

(a) **PRELIMINARY ADJUSTMENT.** Make three chalk marks on the crankshaft damper. Space the marks 90° apart so that with the timing mark, the damper is divided into four equal parts (90° represents ¼ turn of the crankshaft, or ¼ of the distance around the damper circumference).

Rotate the crankshaft until number 1 piston is near T.D.C. at the end of the compression stroke.

Adjust the lash on the following valves:

- No. 1—Exhaust                      No. 1—Intake
- No. 4—Exhaust                      No. 2—Intake
- No. 5—Exhaust                      No. 7—Intake

Rotate the crankshaft 180° or ½ turn (this puts number 4 piston on T.D.C.). Adjust the following valves:

- No. 6—Exhaust                      No. 4—Intake
- No. 8—Exhaust                      No. 5—Intake

Rotate the engine 270° or ¾ turn from 180° (this puts number 3 piston on T.D.C.) and adjust the following valves:

- No. 2—Exhaust                      No. 3—Intake
- No. 3—Exhaust                      No. 6—Intake
- No. 7—Exhaust                      No. 8—Intake

(b) **FINAL ADJUSTMENT.** Run the engine for a minimum of 30 minutes at approximately 1200 r.p.m. in order to stabilize engine temperatures. With the engine idling, check the valve lash. Adjust the lash, if necessary (fig. 24). Install the rocker arm covers.

### e. Valve Timing.

Valve timing checks should be made when poor engine performance is noted, and all other checks, such as carburetion, ignition timing, etc. fail to correct the trouble. The following procedure can be used to determine if the valve timing is correct with the engine installed in the car.

The procedure checks the cam timing by using the opening side of number 1 intake cam lobe. At this point 1° of crankshaft rotation is equal to approximately 0.004 inch change in cam lift.

Remove the rocker arm cover on the 6-cylinder engine. On 8-cylinder engines, remove the right rocker arm cover.

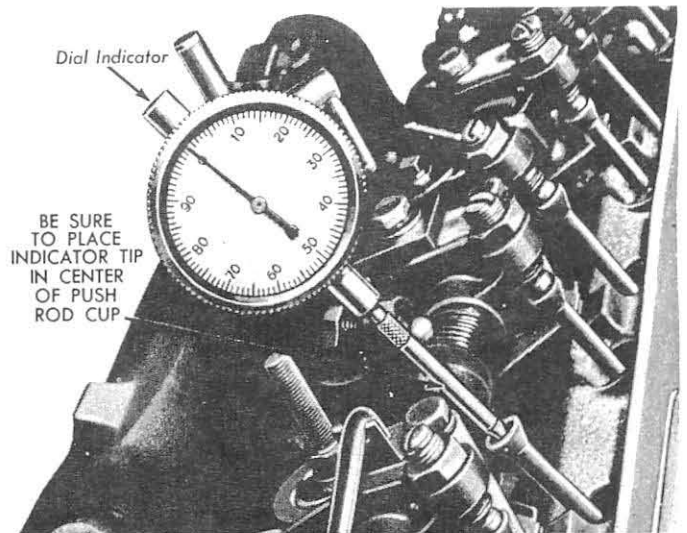

Fig. 25—Camshaft Lobe Lift Check—Typical

Back off the number 1 intake valve adjusting screw, then slide the rocker arm assembly to one side and secure it in this position. Make sure the push rod is in the tappet socket, then install a dial indicator in such a manner as to have the actuating arm of the indicator in the push rod socket and in the same plane as the push rod movement (fig. 25). Turn the engine slowly (at either the crankshaft damper bolt or flywheel) until the tappet is on the heel of the cam lobe. Zero the dial indicator, and continue turning the engine slowly until the desired lift is obtained (Table 3). Compare the degrees on the pulley with specifications.

If the valve timing is not within specifications, check for a bent timing pointer. Bring the number 1 piston to T.D.C. and see if the timing pointer is aligned with the T.D.C. mark on the crankshaft pulley or damper. If the pointer is not at fault, check the timing chain (or timing gears), camshaft sprocket, crankshaft sprocket, camshaft, and crankshaft damper, in the order of accessibility.

Table 3—Valve Timing Specifications

Engine	Intake Tappet Lift (Opens) At Crankshaft Degrees (B.T.D.C.)
223	24° BTDC @ 0.016 Cam Lift
272	12° BTDC @ 0.016 Cam Lift
302	18° BTDC @ 0.010 Cam Lift
332	18° BTDC @ 0.010 Cam Lift

**100% SATISFACTION GUARANTEED**

**BUY IT NOW!**

**Click Here To Order**

PayPal    American Express    Discover    MasterCard    VISA

## TIMING CHAIN AND SPROCKETS, TIMING GEARS, AND CAMSHAFT

ets. (fig. 26), take from the front)

of the chain by rotating the crankshaft in a clockwise direction. Establish a reference point on the block and measure from this point to the chain. Rotate the crank-

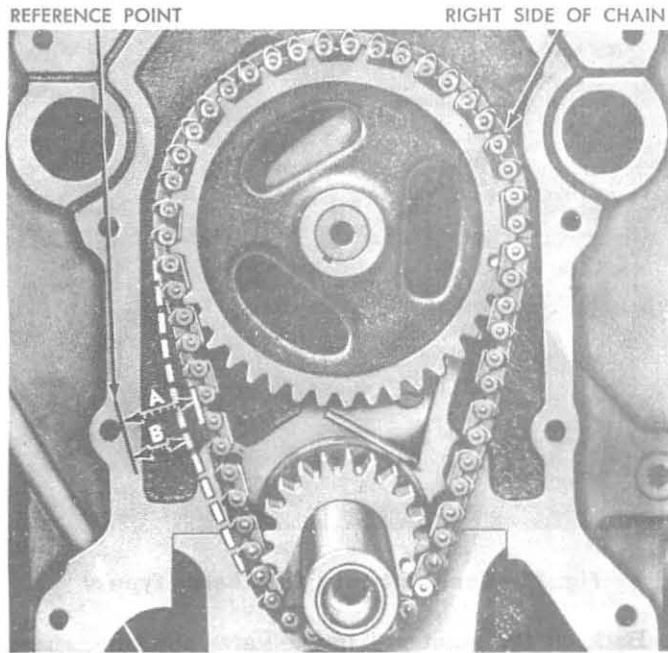

TAKE UP SLACK ON LEFT SIDE OF CHAIN. ESTABLISH A REFERENCE POINT AND MEASURE DISTANCE A. THEN, TAKE UP SLACK ON RIGHT SIDE OF CHAIN AND FORCE LEFT SIDE OF CHAIN OUT WITH THE FINGERS AND MEASURE DISTANCE B. DEFLECTION IS A. MINUS B. 6608

Fig. 26—Timing Chain Deflection—Typical

shaft to move all the slack to the left side. With the fingers, move the chain toward the original reference point and measure the distance between the reference point and the chain. If the difference between the two measurements (which is the slack) exceeds 1/2 inch, replace the timing chain and/or sprockets.

Inspect the sprockets for worn or damaged teeth and the chain for broken links. Replace the sprockets or the timing chain as deemed necessary by inspection. However, it is recommended that all the components be replaced if any one item needs replacement.

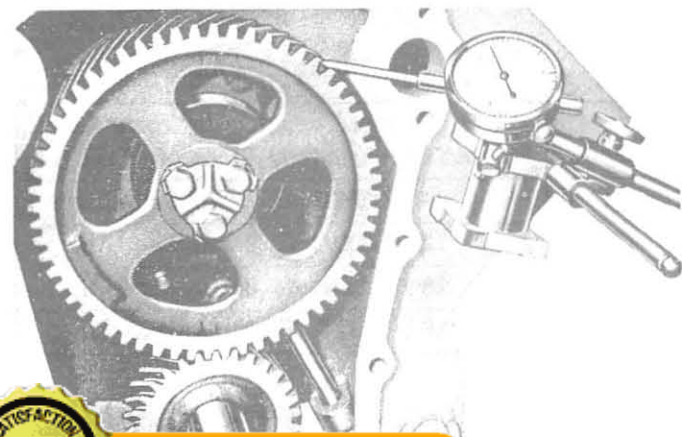

6492

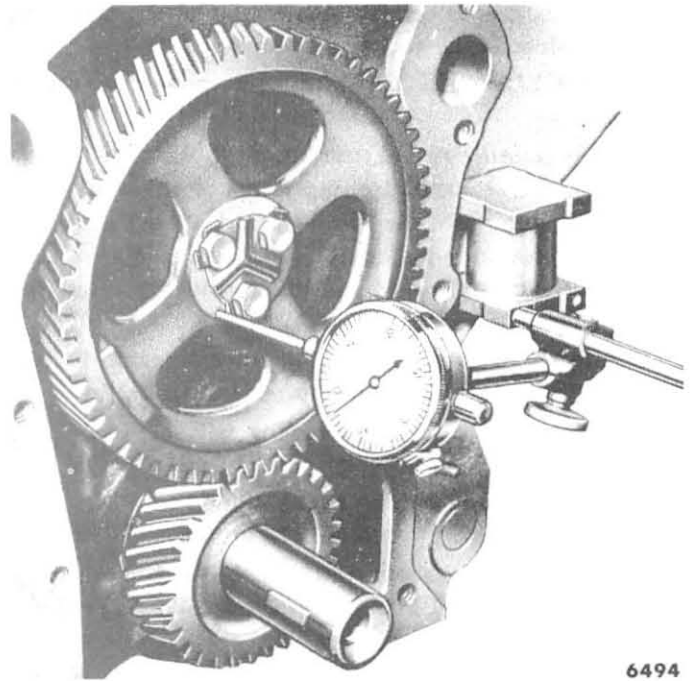

6494

Fig. 28—Camshaft Gear Runout

### b. Timing Gears.

The following checks apply to the 302 and 332 cubic inch engines.

(1) **BACKLASH.** Check the backlash between the camshaft gear and the crankshaft gear with a dial indicator (fig. 27). Hold the gear firmly against the block while making the check. The backlash limits are listed in the Specification Section.

(2) **RUNOUT CHECK.** Check the camshaft and crankshaft gear runout with a dial indicator (fig. 28). The camshaft gear runout should not exceed 0.008 inch and the crankshaft gear runout should not exceed 0.007 inch. If the gear runout is excessive, remove the gear and clean any burrs from the shaft, or replace the gear and/or gears. It is good practice to replace both gears when either gear needs replacing.

(3) **INSPECTION.** Clean the gears in solvent. Note the condition of the gear teeth. If the teeth are scored or the contact pattern on the teeth is uneven, replace the gear and/or gears.

### c. Camshaft.

The camshaft should be replaced when any lobe (intake or exhaust) is worn to such an extent that the lift loss exceeds 0.005 inch. The tappet which mates with the worn lobe must also be replaced.

(1) **CAM LOBE LIFT CHECK.** This procedure is similar to the procedure for checking valve timing. Loosen the valve rocker arm adjusting screw, then slide the rocker arm assembly to one side and secure it in

**100% SATISFACTION GUARANTEED**

**BUY IT NOW!**

**Click Here To Order**

PayPal    American Express    Discover    MasterCard    VISA

ish Check

this position. Make sure the push rod is in the tappet socket, then install a dial indicator in such a manner as to have the actuating point of the indicator in the push rod socket and in the same plane as the push rod movement (fig. 25). Rotate the engine slowly until the tappet is on the heel of the cam lobe. Zero the dial indicator, then continue to rotate the engine slowly until the push rod is in the fully raised position. Compare the total lift recorded on the indicator to specifications. Continue to rotate the engine until the indicator reads zero. This later step is a check on the accuracy of the original indicator reading.

(2) **INSPECTION.** Thoroughly check the camshaft for cracks. Examine the lobes for pitting, scoring, and signs of abnormal wear. Check the lobes with a micrometer. Suspected worn lobes should be compared with a good lobe to be sure diagnosis is correct. Measure the journal diameter for wear and out-of-roundness. Measure the I.D. of the camshaft bearings. If the clearances are excessive the cam and/or cam bearings should be replaced. Check the fuel pump eccentric for wear.

(3) **REPAIRS.** Replace all camshafts that are damaged beyond repair. Remove light scuffs, scores, or nicks with a hard Arkansas stone, then polish with crocus cloth.

The lobe wear characteristics may result in pitting in the general area of the nose portion of the lobe. This pitting is not detrimental to the operation of the cam if the initial cam lobe lift loss has not exceeded 0.005 inch. The camshaft will continue to operate satisfactorily for the normal life expectancy of the engine without noticeably affecting engine performance. Therefore, camshafts should not be replaced unless the lobe lift loss exceeds the above specification or the tappet contact face shows evidence of failure.

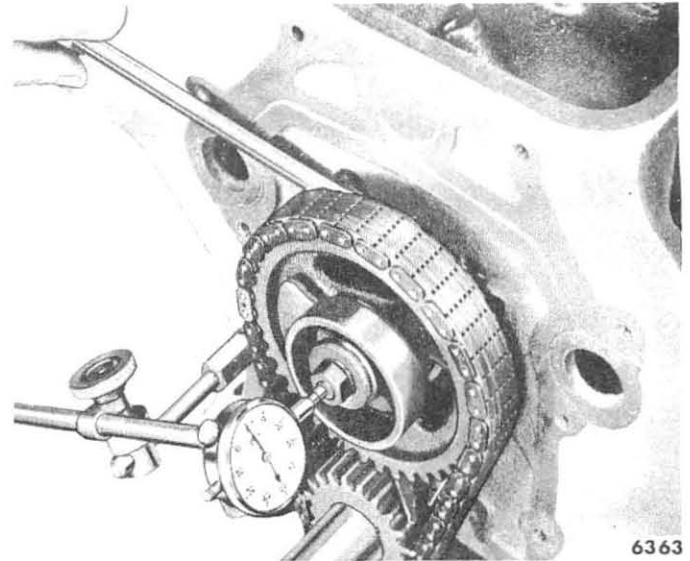

Fig. 29—Camshaft End Play Check—Typical

Normally, if the front journal to bearing clearance is excessive, it can be assumed that all bearings are worn and need replacement.

If any of the teeth on the distributor drive gear are broken or worn, it will be necessary to replace the camshaft.

(4) **CAMSHAFT END PLAY CHECK.** Push the camshaft toward the rear of the engine. Place a dial indicator point against a suitable surface on the front end of the camshaft assembly (fig. 29). Set the dial to zero, then pull the camshaft forward and release it. Compare the dial reading with specifications.

If the end play is excessive, check the spacer for correct installation. Replace the thrust plate and/or spacer if necessary.

## 7. FLYWHEEL, CRANKSHAFT, AND MAIN BEARINGS

Procedures for the inspection and repair of these components are given here. In addition, procedures for fitting main bearings, thrust bearing alignment, and replacing the rear main bearing crankshaft oil seal are given.

### a. Flywheel.

The flywheel and ring gear are a shrink fit and are replaceable as separate parts.

**INSPECTION.** Check the flywheel face runout with a dial indicator (fig. 30). Be sure to hold the flywheel against the crankshaft flange. Check the flywheel runout. If the flywheel runout is excessive, replace the flywheel, and check the crankshaft flange. It will be

necessary to remove the crankshaft if the flange requires machining.

Inspect the ring gear for worn, chipped or cracked teeth. Check the ring gear runout as indicated in fig. 31.

(2) **REPAIRS.** If the flywheel runout is excessive and the flange is not at fault, replace or machine the flywheel. Machine the friction surface of the flywheel if it is scored or worn. If it is necessary to remove more than 0.045 inch of stock from the original thickness, replace the flywheel.

If the ring gear teeth are damaged and unfit for further use, or if the runout is excessive, replace the ring gear as follows:

Heat the defective ring gear with a blow torch on the engine side of the gear, then knock it off the flywheel.



**BUY IT NOW!**

**Click Here To Order**



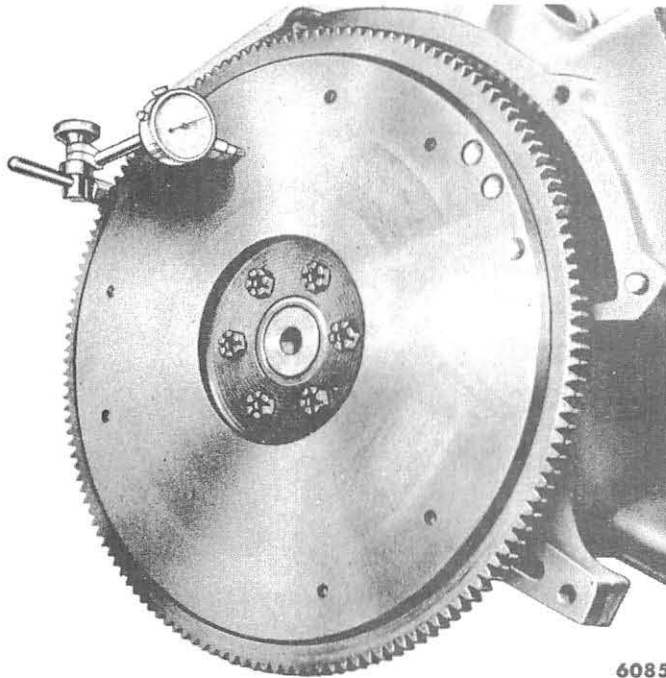

Fig. 30—Flywheel Runout Check

**CAUTION:** Do not hit the flywheel when removing the ring gear.

Heat the new ring gear evenly until the gear expands enough to slip onto the flywheel. Make sure the gear is seated properly against the shoulder.

**CAUTION:** Do not heat any portion of the gear to a temperature higher than 500° F. If this limit is exceeded, the temper will be removed from the ring



6084

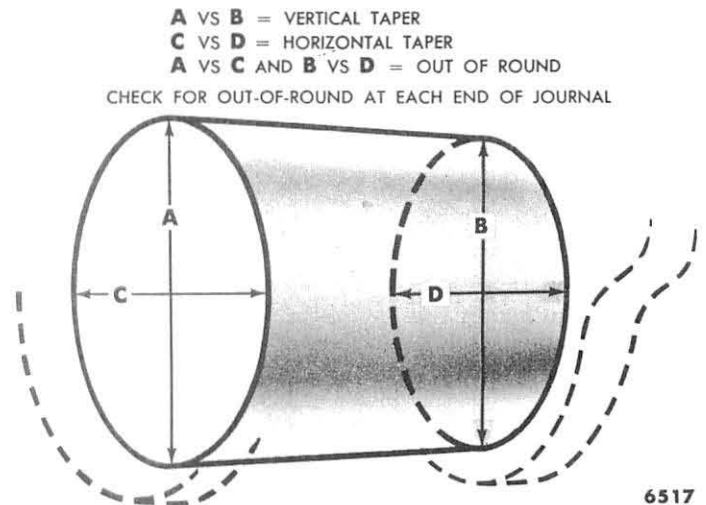

Fig. 32—Crankshaft Journal Check

gear teeth. When the new ring gear is installed, perform a runout check on the ring gear and flywheel.

## b. Crankshaft.

Check the end play for conformance to specification in the following manner:

Push the crankshaft toward the rear of the engine. Place a dial indicator point against the rear or front end of the crankshaft flange. Set the dial on zero then push the crankshaft forward. Compare the reading on the dial indicator with specifications.

(1) **CLEANING AND INSPECTION.** Remove the crankshaft, wash it in a solvent, and blow out the oil passages with compressed air. Examine the shaft for damage.

Measure the diameter of each journal in at least four places to determine out-of-roundness, taper, or undersize condition (fig. 32).

(2) **REPAIRS.** If the end play is excessive, replace the thrust bearing.

Replace the crankshaft if it shows signs of failure. Dress minor nicks or scratches.

If the pins or journals are out-of-round beyond further use, the shaft should be ground for the next undersize bearing. Calculate the correct undersize bearing to be used as follows:

**EXAMPLE:** If the main bearing journal will “clean-up” before it is ground to  $2.499 - 0.010 = 2.489$  inches diameter, finish it to that diameter, and install 0.010 undersize bearings.

Always reproduce the same radii in the corners of the journals that existed originally. Too small a radius may

**100% SATISFACTION GUARANTEED**

**BUY IT NOW!**

**Click Here To Order**

Check

PayPal

MasterCard

DISCOVER

AMERICAN EXPRESS

VISA

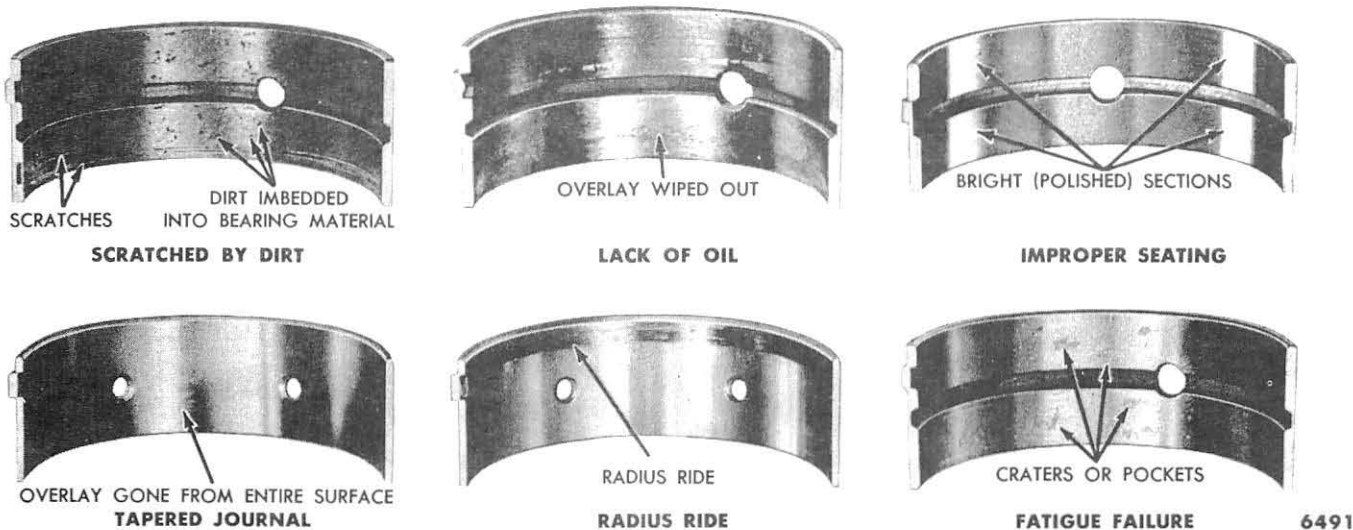

Fig. 33—Bearing Failures—Typical

result in crankshaft failure, while too large a radius will result in bearing failure.

**CAUTION:** *Never grind journals or crankpins in excess of 0.030-inch undersize.*

After grinding, chamfer the oil holes, then polish the pin or journal with No. 320 grit polishing cloth and engine oil. Crocus cloth may also be used as a polishing agent.

**c. Main Bearings.**

The insert-type main bearings are select fit. They are available for service in standard and undersizes for use on journals that have been reground. The installation of new bearings must be closely checked to maintain the proper clearance between the journals and bearing surfaces.

(1) **INSPECTION.** Check the bearings for any damage or excessive clearance. Examples of bearing failures and their causes are illustrated in fig. 33.

(2) **FITTING MAIN BEARINGS — PLASTIGAGE METHOD.** The following procedure applies to fitting main bearings with the engine either installed on a workstand or in the truck.

If the bearing fits are to be checked with the engine in the truck, support the weight of the crankshaft with a small jack positioned to hold the crankshaft upward against the block half of the main bearings. Place the jack to bear against the crankshaft counterweight adjacent bearing which is being checked for clearance. It can also be supported by a thin rubber pad between two bearings. These bearing cap bolts are tightened up against the

**NOTE:** *It is necessary to support the weight of the crankshaft when checking main bearing clearances to prevent the weight of the crankshaft from compressing the Plastigage, thereby providing an erroneous reading.*

Place a piece of Plastigage, the full width of the bearing, on the bearing surface (or on the crankshaft journal if the engine is inverted) about 1/4-inch off center. Install the cap and tighten the bolts to specifications.

**CAUTION:** *Do not turn the crankshaft while the Plastigage is in place.*

Remove the cap, then check the width of the Plastigage at the widest point with the Plastigage scale (fig. 34).

If the clearance is excessive, try another selective fit bearing to bring the clearance within the desired limit.

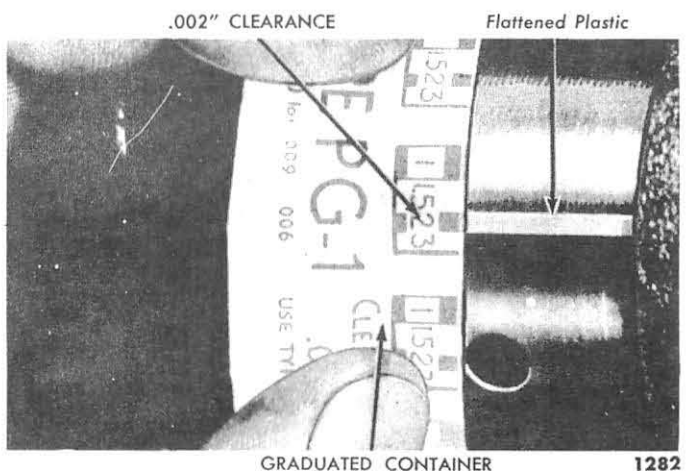

Fig. 34—Measuring Plastigage—Typical

**100% SATISFACTION GUARANTEED**

**BUY IT NOW!**

**Click Here To Order**

PayPal, American Express, Discover, MasterCard, VISA

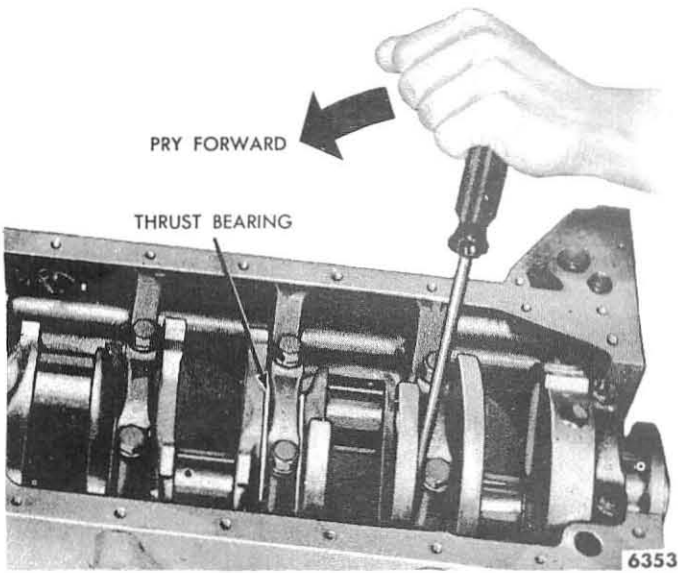

Fig. 35—Pry Crankshaft Forward—Typical

**NOTE:** Red marked bearings increase clearance, blue marked bearings decrease clearance.

If the various selective fit bearings do not bring the clearance within desired limits, grind the crankshaft journal and/or journals and install undersize bearings.

**NOTE:** Normally, main bearing journals wear evenly and are not out-of-round. However, if a bearing is being fitted to an out-of-round journal, be sure to fit the bearing to the maximum diameter of the journal. If the bearing is fitted to the minimum diameter with minimum clearance, interference may result, causing an early failure. It is not recommended that bearings

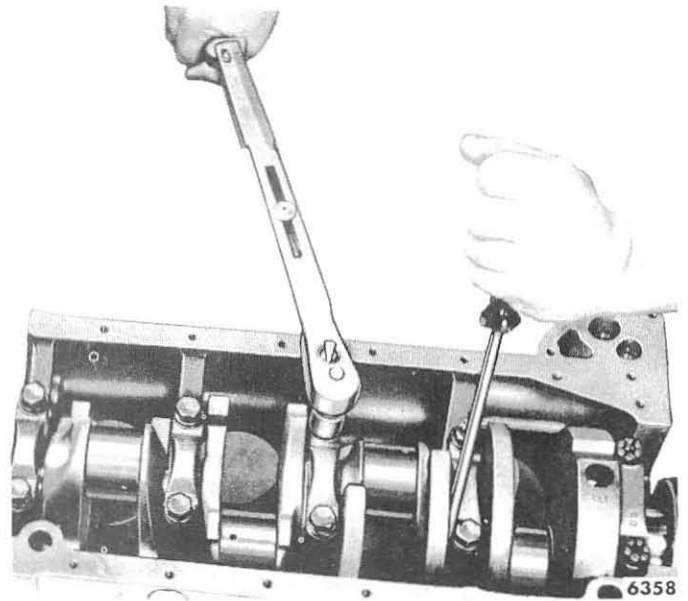
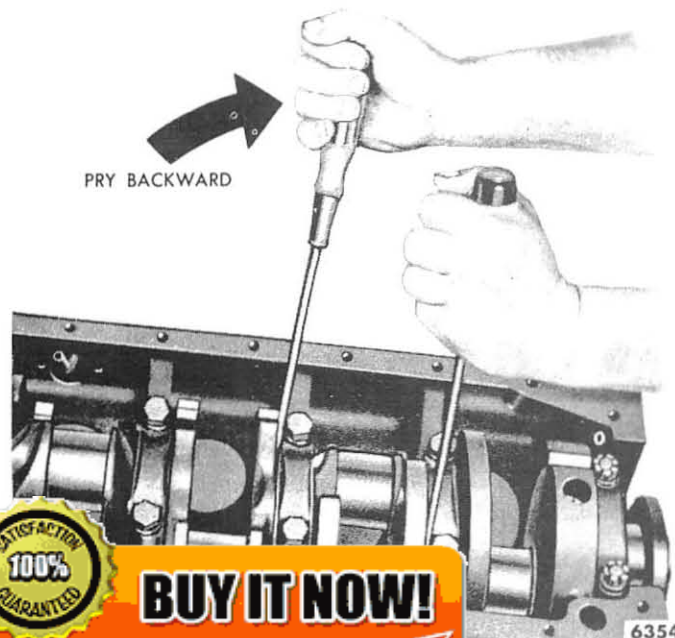

Fig. 37—Tighten Cap—Typical

be fitted to a crankshaft journal which is more than 0.001-inch out-of-round.

(3) **THRUST BEARING ALIGNMENT.** Install the main bearing caps, except the thrust bearing cap, and tighten the cap bolts to specifications. Install the thrust bearing cap with the bolts finger-tight, then pry the crankshaft forward to properly position the thrust surface of the upper half of the bearing (fig. 35). While holding the crankshaft forward, pry the thrust bearing cap to the rear (fig. 36). This will align the thrust sur-



Typical

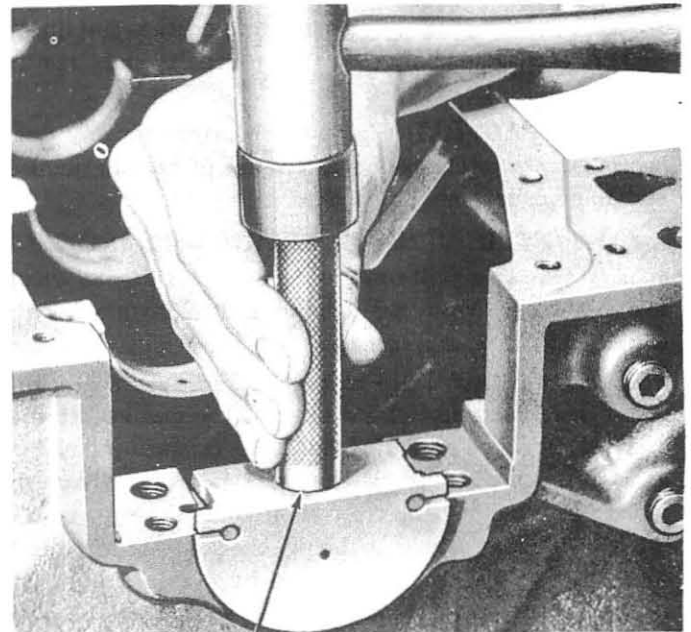

Tool— T52L-6701-AGD (223 OR 272 CUBIC INCH ENGINE)  
Tool— T52T-6701-AJD (302 OR 332 CUBIC INCH ENGINE)

6638

Fig. 38—Oil Seal to Block Installation—Typical

**100% SATISFACTION GUARANTEED**

**BUY IT NOW!**

**Click Here To Order**

faces of both halves of the bearing. Retain the forward pressure on the crankshaft, and tighten the cap bolts to specifications (fig. 37). Check the crankshaft end play.

(4) **REPLACING REAR MAIN BEARING CRANKSHAFT OIL SEALS.** Remove the crankshaft journal oil seals from the cylinder block and seal retainer, or bearing cap. Clean the seal grooves.

Install a new seal in the cylinder block as shown in fig. 38. After installation, cut the seal flush without any frayed edges overlapping. Install the new journal seal in its retainer or bearing cap as shown in fig. 39. After installation cut the seals flush.

Coat the rear oil seal retainer to block mating face with sealer, install the retainer and tighten the bolts to 23-28 foot-pounds torque. Dip the side seals in light engine oil, then immediately install them in the grooves. It may be necessary to tap the seals into place for the last ½ inch of travel. Do not cut the seal projecting ends.

**CAUTION:** Do not use sealer on the side seals. The seals are designed to expand when dipped in oil. Using sealer may retard this expansion.

To check retainer or bearing cap side seals for leaks, squirt a few drops of oil into the parting lines between the cap or retainer and the cylinder block from the outside. Blow compressed air against the seals from the inside of the block. If air bubbles appear in the oil, it

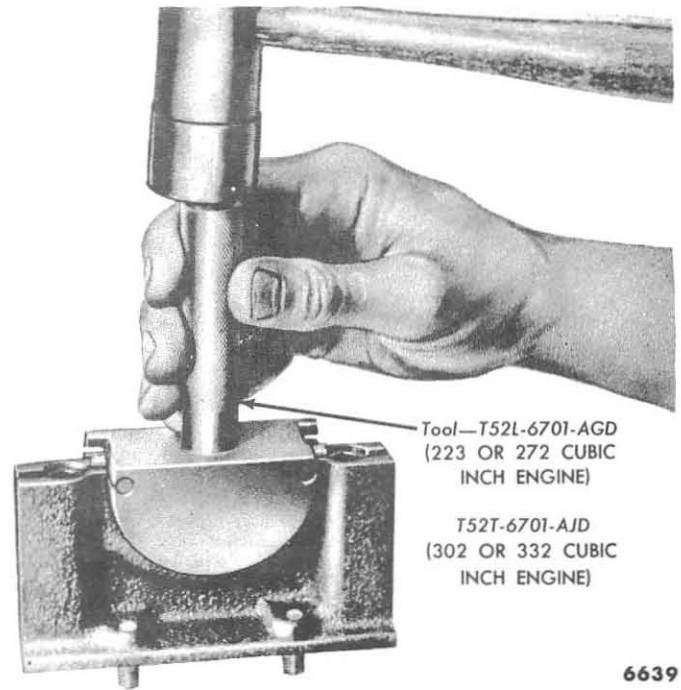

6639

Fig. 39—Oil Seal to Retainer Installation—Typical

indicates possible oil leakage.

**NOTE:** The above test should not be performed on newly installed seals until sufficient time has been allowed for the seals to expand into the seal grooves.

## 8. CYLINDER BLOCK, PISTONS, PISTON RINGS, AND CONNECTING RODS AND BEARINGS

During the disassembly of the cylinder block for engine overhaul, closely inspect the wear pattern on all parts to help diagnose the cause of wear.

### a. Cylinder Block.

Clean old gasket material from all machined surfaces. Remove the pipe plugs which seal oil passages and clean all passages thoroughly.

(1) **INSPECTION.** Make a thorough check for cracks. Minute cracks not visible to the naked eye may be detected by coating the suspected area with a mixture of 25% kerosene and 75% light motor oil. Wipe the part dry and immediately apply a coating of zinc oxide dissolved in wood alcohol. If cracks are present, the coating will become discolored at the defective area.

Make sure the threads in the head bolt holes are true in the threads can cause binding and result in true up threads

the measurements (fig. 40). Follow the instructions of the tool manufacturer. Only experienced personnel should be permitted to take these measurements.

Inspect all expansion-type plugs for evidence of leakage.

(2) **REPAIRS.** To remove an expansion-type plug, drill a ½ inch hole in the center of the plug and remove the plug as shown in fig. 41. Clean the plug recess thoroughly. Coat the flange of the new plug with sealer and install it with the flange facing out. Drive the plug in until the flange is flush or slightly below the casting surface (fig. 42).

**NOTE:** A 0.030 inch oversize plug is available.

Rebore cylinders that are deeply scored and when taper and/or when out-of-roundness are excessive. If the cylinder bore and piston wear are not excessive, new service piston rings will give satisfactory performance.

(3) **BORING CYLINDER BLOCK.** Follow the boring equipment manufacturer's instructions. This work should be performed by experienced personnel only.

Bore the cylinder with the most wear first to deter-

100% SATISFACTION GUARANTEED

**BUY IT NOW!**

Click Here To Order

PayPal American Express Discover Novus MasterCard VISA

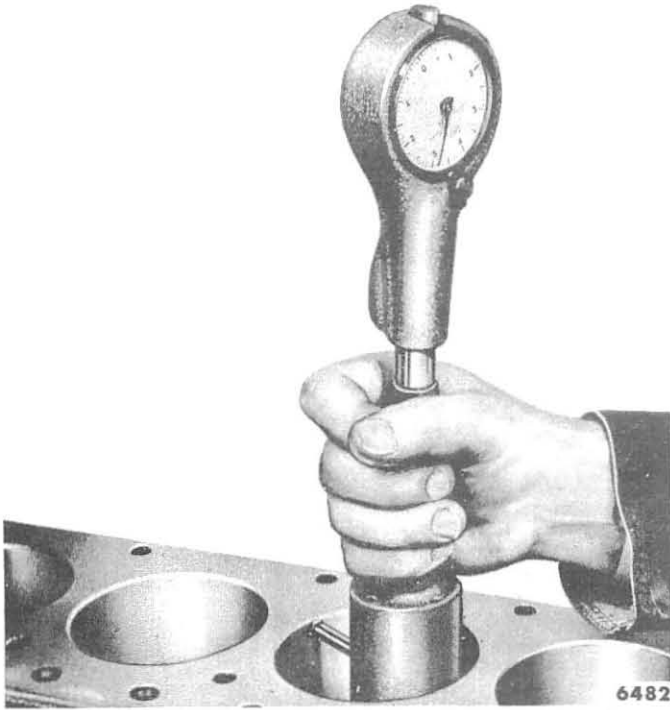
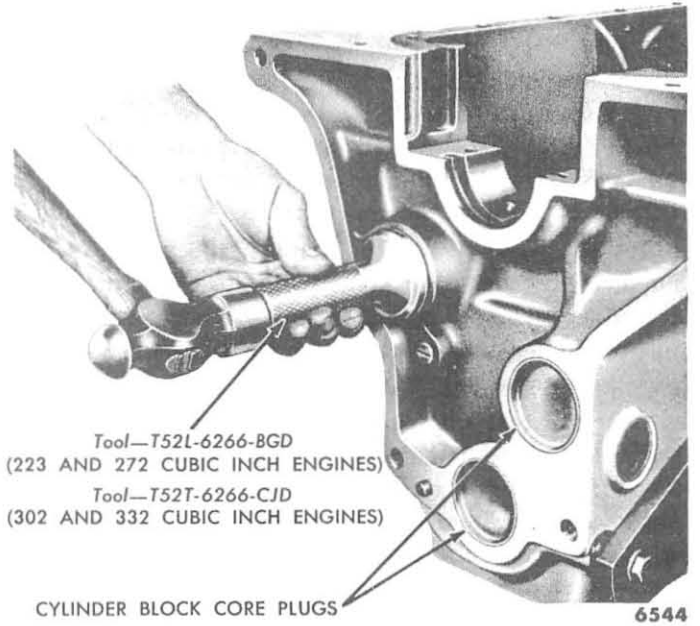

Fig. 40—Cylinder Bore Measurement—Typical

mine the proper oversize. If this cylinder will not clean up when bored for the maximum oversize piston recommended, the block should be replaced. Bore the cylinder to within approximately 0.0015 inch of the required oversize diameter. This will allow enough stock for the final step of honing the bores so the correct surface finish and pattern are obtained. Use a number 220-280 grit hone for this operation.

**CAUTION:** *Thoroughly clean the block to remove all particles after the boring and honing operations, then coat the bores with oil.*

(4) **CYLINDER BORE “GLAZE” REMOVAL.** Whenever piston rings are installed in a used cylinder remove the “glaze” on the bore to aid in ring seating. Take all necessary precautions to catch the grit. Pass



Tool—T52L-6266-BGD  
(223 AND 272 CUBIC INCH ENGINES)  
Tool—T52T-6266-CJD  
(302 AND 332 CUBIC INCH ENGINES)  
CYLINDER BLOCK CORE PLUGS

Fig. 42—Expansion-Type Plug Installation—Typical

a hone or glaze removing tool through the cylinder bore a few times. Do not hone more than enough to rough up the finish. Thoroughly clean the cylinder bore and block after glaze removal, then oil the bores.

**b. Pistons, Pins, and Rings.**

(1) **CLEANING AND INSPECTION.** Remove the carbon deposits from the piston. Clean the piston ring grooves with a ring groove cleaner (fig. 43). Make sure the oil ring slots (or holes) are clean.

**CAUTION:** *Do not use a caustic cleaning solution or a wire brush.*

Inspect pistons for fractures at the ring lands, skirt, and pin bosses, and for scuffed or scored skirts. Spongy, eroded areas near the edge of the piston top are usually caused by detonation, or pre-ignition. A shiny surface on the thrust surface of the piston, offset from the centerline between the piston pin holes, can be caused by



Tool—7600-N

6600  
Removal—Typical

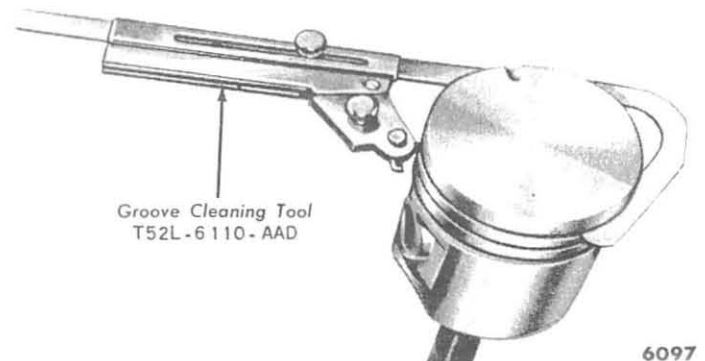

Groove Cleaning Tool  
T52L-6110-AAD

Fig. 43—Cleaning Ring Grooves

**SATISFACTION 100% GUARANTEED**

**BUY IT NOW!**

**Click Here To Order**

PayPal, American Express, Discover, MasterCard, VISA

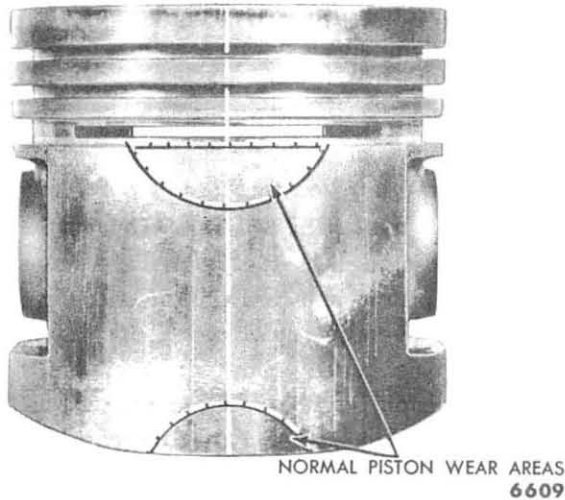

Fig. 44—Normal Wear Pattern

a bent connecting rod. The normal wear pattern of a piston is shown in fig. 44.

Inspect the piston pins for signs of fracture or etching. Check the pin for proper fit in the piston and rod bushing. Check for wear in the pin retainer grooves.

(2) **REPAIRS.** Replace pistons showing signs of excessive skirt clearance, or ring side clearance, wavy ring lands, fractures or damage from detonation or pre-ignition.

Replace piston pins showing signs of fracture or etching. Piston pins that show wear or fit loosely in the piston or rod bushing should be replaced. Replace all piston pin retainers.

(3) **FITTING PISTONS.** Pistons of 0.020, 0.030, 0.040, 0.060 inch oversize are available for most engines. Check the parts catalogue for sizes available.

To fit a piston in a cylinder bore, calculate the size piston desired by taking a bore check (fig. 40) and select the proper size piston to provide the desired clearance. Check the piston being fitted by attaching a tension scale to the end of a feeler gauge ribbon ( $\frac{1}{2}$  inch wide) of the proper thickness. Position the feeler on the side of the piston  $90^\circ$  from the piston pin hole. Invert the piston, then push the piston and feeler into the bore parallel to the crankshaft axis. Hold the piston and pull out the feeler ribbon, noting the reading on the pull scale (fig. 45).

If the scale reading is greater than the maximum allowable pull, recheck calculations to be sure the proper piston has been selected, check for a damaged piston, or try another piston to obtain the

minimum allowable pull. If necessary, try another

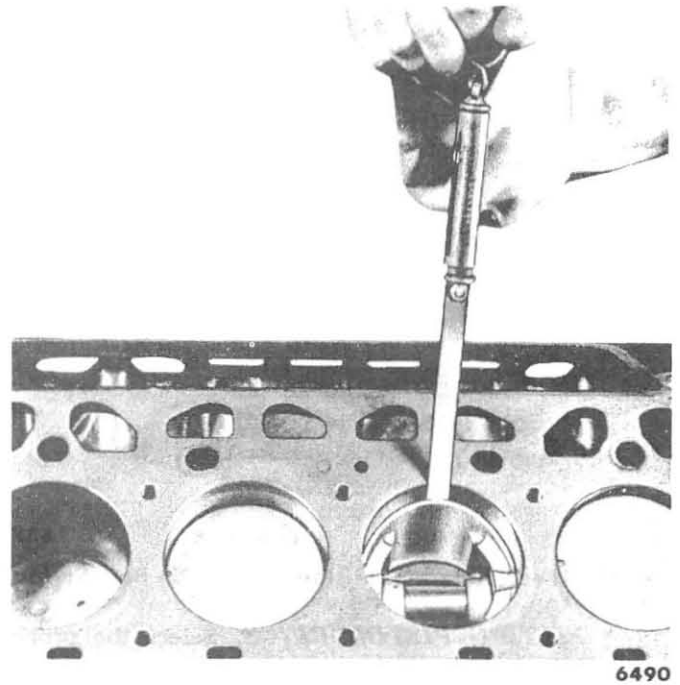

Fig. 45—Fitting Piston—Typical

piston. If none can be fitted, bore the cylinder to the next size piston. When a piston has been fitted, mark it for assembly in the cylinder to which it was fitted.

**NOTE:** All pistons are the same weight, both standard and oversize; therefore, pistons of various sizes can be intermixed without upsetting engine balance. Re-bore only the cylinder or cylinders which require it.

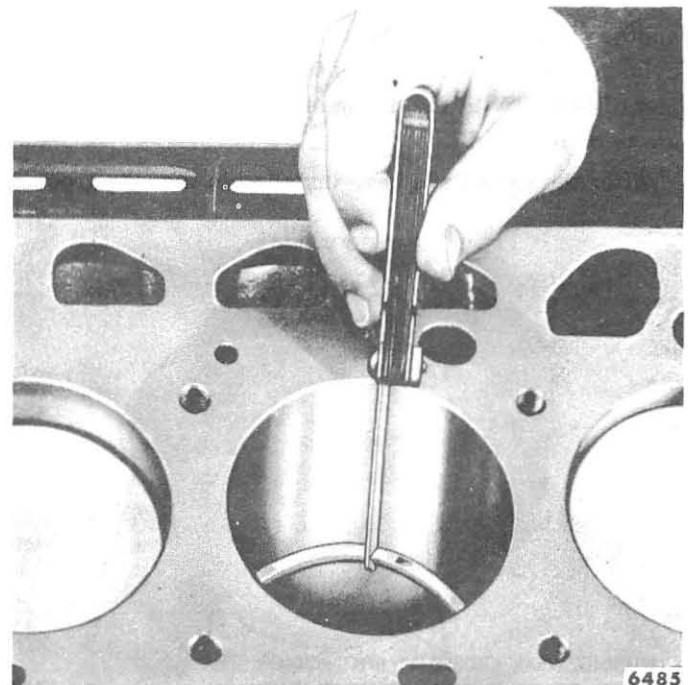

Fig. 46—Measuring Piston Ring Gap—Typical

**100% SATISFACTION GUARANTEED**

**BUY IT NOW!**

**Click Here To Order**

PayPal    American Express    Discover    MasterCard    VISA

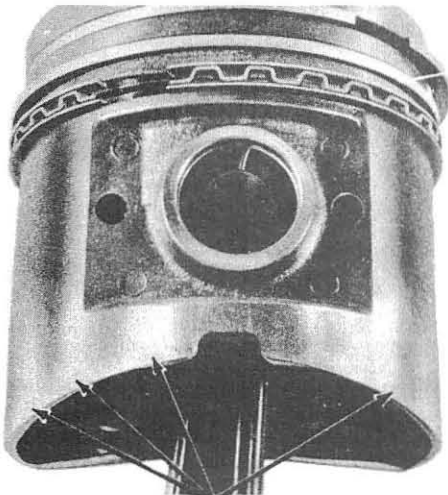

PISTON WEAR CAUSED BY BENT ROD  
OR MISALIGNED PISTON PIN HOLE

6371

**Fig. 47—Wear Pattern on Piston—Piston Pin Boss Surface**

(4) **FITTING PISTON RINGS.** Select the proper ring set for the size piston to be used. Before the rings are installed on the piston, check each ring for proper gap as follows:

Position the ring in the cylinder bore in which it is going to be used. Push the ring down into the bore area where normal ring wear is not encountered. Use the head of a piston to position the ring in the bore so the ring is square with the cylinder wall. Use caution during this operation to avoid damage to the ring or cylinder bore. Measure the gap between the ends of the ring with a feeler gauge (fig. 46). The gap should be from 0.010–0.027 inch. If the gap is less than the lower limit, try another ring set. After the rings have been fitted in the cylinder bore, immediately install them on the piston or identify them with the piston and cylinder in which they are to be installed.

After the rings have been installed in the ring grooves



6372

Connecting Rod Bearing

according to the instructions on the piston ring package, check the ring side clearance with a feeler gauge. The gauge should slide freely around the entire piston ring circumference without binding.

If the rings are to be installed in a used cylinder, remove the “glaze” on the bore as previously explained.

(5) **FITTING PISTON PIN.** The piston pin should be a light thumb press fit at normal temperature (70°F). Standard piston pins are color coded green. Pins of 0.001 inch oversize (color coded blue) and 0.002 inch oversize (color coded yellow) are available.

If the piston pin hole must be reamed, use an expansion-type piloted reamer. Place the reamer in a vise and revolve the piston around the reamer. Set the reamer to the size of the pin bore, then expand the reamer slightly and trial ream the pin bore. Take a light cut. Use a pilot sleeve of the nearest size to maintain alignment of the bores.

Check the reamed hole size, using the new piston pin. If the bore is small, expand the reamer slightly and make another cut. Repeat the procedure until the proper fit is obtained. Check the fitted piston pin for fit in the respective rod bushing. Ream the bushing if necessary to fit the pin.

Install a retainer at each end of the pin to hold it in place. When the retainers are installed, make sure they are properly seated in the grooves provided in the piston pin bore. Always use new retainers.

### c. Connecting Rod.

The connecting rods and related parts should be carefully inspected and checked for conformance to specifications. Various forms of engine wear which are caused by these parts can be readily identified as follows:

A shiny surface on the pin boss side of the piston usually indicates that a connecting rod is bent or the piston pin hole is not in proper relation to the piston skirt and ring grooves (fig. 47).

Abnormal connecting rod bearing wear can be caused by either a bent connecting rod, a crankshaft journal improperly machined, or a tapered connecting rod bore (fig. 48).

Twisted connecting rods will not create an easily identifiable wear pattern, but badly twisted rods will disturb the normal actions of the entire piston, ring, and rod assembly that may result in excessive oil consumption.

(1) **CLEANING AND INSPECTION.** Clean all parts and passages in solvent. Never use a caustic cleaning solution. Remove the bearings (identify them if they are to be used again), then thoroughly clean the rod bore



**BUY IT NOW!**

**Click Here To Order**

