

1956

FORD

car



Shop Manual



BUY IT NOW!

Click Here To Order

PayPal

Discover
Cards

DISCOVER
NOW!

MasterCard

VISA

DIVISION

FORD MOTOR COMPANY

Copyright © 2009, Forel Publishing Company, LLC, Woodbridge, Virginia

All Rights Reserved. No part of this book may be used or reproduced in any manner whatsoever without written permission of Forel Publishing Company, LLC. For information write to Forel Publishing Company, LLC, 3999 Peregrine Ridge Ct., Woodbridge, VA 22192

1956 Ford Car Shop Manual

EAN: 978-1-60371-006-0

ISBN: 1-60371-006-X

Forel Publishing Company, LLC

3999 Peregrine Ridge Ct.

Woodbridge, VA 22192

Email address: webmaster@ForelPublishing.com

Website: <http://www.ForelPublishing.com>



This publication contains material that is reproduced and distributed under a license from Ford Motor Company. No further reproduction or distribution of the Ford Motor Company material is allowed without the express written permission of Ford Motor Company.

Note from the Editor

This product was created from the original Ford Motor Company's publication. Every effort has been made to use the original scanned images, however, due to the condition of the material; some pages have been modified to remove imperfections.

Disclaimer

Although every effort was made to ensure the accuracy of this book, no representations or warranties of any kind are made concerning the accuracy, completeness or suitability of the information, either expressed or implied. As a result, the information contained within this book should be used as general information only. The author and Forel Publishing Company, LLC shall have neither liability nor responsibility to any person or entity with respect to any loss or damage caused, or alleged to be caused, directly or indirectly by the information contained in this book. Further, the publisher and author are not engaged in rendering legal or other professional services. If legal, mechanical, electrical, or other expert assistance is required, the professional should be sought.



1 9 5 6

FORD

car

Shop Manual



Copyright 1955
FORD MOTOR COMPANY

BUY IT NOW!

Click Here To Order

Motor Company - February 2002.

September, 1955



F O R D

D I V I S I O N

M O T O R C O M P A N Y

FOREWORD

This manual has been prepared to provide information for the proper servicing of 1956 Ford Cars and the 1956 Ford Thunderbird. The manual should be kept where it will be readily available for reference at all times. The service procedures are accompanied by illustrations of many of the service operations. Disassembled views of some of the car units are also given.

The manual is divided into five main parts as listed in the Table of Contents on the following pages.

Part ONE—POWER PLANT—is composed of the various engines and their related systems, which are ignition, fuel, and cooling.

Part TWO—CHASSIS—includes information on the entire power train (clutch, conventional transmission, Overdrive, drive line, rear axle, etc.) and the running gear (frames, springs, suspension, brakes, wheels, tires, steering gear, steering linkages, etc.). Service procedures for the Fordomatic transmission are published in a separate manual.

Part THREE—ELECTRICAL AND ACCESSORIES—covers all of the electrical systems and units (except the ignition system) and all of the accessories (except the Overdrive and Fordomatic).

Part FOUR—BODIES—contains information on the maintenance and repair of all body components, including adjustment and alignment of doors, hoods, and fenders. Window glass adjustments are also included in this part.

Part FIVE—MAINTENANCE AND SPECIFICATIONS—includes complete maintenance and lubrication information, and contains all the specifications necessary for properly servicing Ford cars.

The page headings, throughout the manual, designate the subject matter covered. The heading on each left-hand or even-numbered page indicates the name of the chapter and the heading on each right-hand or odd-numbered page indicates the section covered.

The descriptions and specifications contained in this manual were in effect at the time the book was approved for printing. The Ford Division of Ford Motor Company reserves the right to discontinue models at any time, or change specifications or design, without notice and without incurring obligation.

SERVICE DEPARTMENT
FORD DIVISION
FORD MOTOR COMPANY



TABLE OF CONTENTS

Foreword	Page	2
----------	------	---

Part ONE—POWER PLANT

CHAPTER I—GENERAL ENGINE OVERHAUL, INSPECTION, AND REPAIR

	Page		Page		
Section 1	Trouble Shooting	5	Section 6	Timing Chain, Sprockets and Camshaft	20
2	Tune-Up	8	7	Flywheel, Crankshaft and Main Bearings	22
3	Engine Removal and Installation	10	8	Cylinder Block, Pistons, Piston Rings, and Connecting Rods and Bearings	25
4	Intake and Exhaust Manifolds	14	9	Oil Pan and Oil Pump	29
5	Rocker Mechanism, Cylinder Head, Valves, Valve Lash Adjustment, and Valve Timing	15	10	Exhaust System	30

CHAPTER II—6-CYLINDER ENGINE

Section 1	Engine Steady Rest	31	Section 7	Flywheel, Crankshaft, and Main Bearings	39
2	Manifolds	32	8	Connecting Rods and Bearings, Pistons, Pins, and Rings	42
3	Cylinder Head and Valves	33	9	Oil Pan, Oil Filter and Oil Pump	44
4	Crankshaft Damper	36	10	Exhaust System	45
5	Cylinder Front Cover and Crankshaft Oil Seal	36			
6	Sprocket and Timing Chain, Camshaft and Bearings, and Tappets	37			

CHAPTER III—8-CYLINDER ENGINES

Section 1	General Information	47	Section 7	Sprockets and Timing Chain, Camshaft and Bearings, and Tappets	56
2	Engine Steady Rest	49	8	Flywheel, Crankshaft, and Main Bearings	60
3	Manifolds	49	9	Connecting Rods and Bearings, Pistons, Pins, and Rings	62
4	Cylinder Heads and Valves	51	10	Oil Pan, Oil Filter, and Oil Pump	64
5	Crankshaft Damper	54	11	Exhaust System	66
6	Cylinder Front Cover and Crankshaft Oil Seal	55			

CHAPTER IV—IGNITION, FUEL, AND COOLING SYSTEMS

Section 1	Ignition System	69	Section 7	Four-Barrel Carburetor Operation, Adjustments, and Overhaul	95
2	Distributor Minor Repair and Adjustments	74	8	Fuel Pumps, Vacuum Booster, and Fuel Filter	108
3	Distributor Overhaul	78	9	Fuel Tanks and Lines	110
4	Carburetor Operation and Adjustments—Single and Dual Carburetors	84	10	Fans and Belts	111
5	Single Barrel Carburetor Overhaul	89	11	Water Pumps	112
6	Dual Carburetor Overhaul	92	12	Radiator, Hose, and Thermostat	115

Part TWO—CHASSIS

CHAPTER I—CLUTCH, TRANSMISSION, AND GEAR SHIFT LINKAGE

Section 1	Trouble Shooting	117	Section 5	Conventional 3-Speed Transmission	125
2	Clutch	119	6	Overdrive Transmission	129
3	Flywheel Housing Alignment	123	7	Gear Shift Linkage	138
4	Transmission Cleaning and Inspection	124			

CHAPTER II—REAR AXLES AND DRIVE LINES

Section 1	Trouble Shooting	141	Section 4	Integral Housing Hypoid Rear Axle	152
2	Cleaning and Inspection	142	5	Drive Lines	158
3	Banjo Housing Hypoid Rear Axle	143			

CHAPTER III—RUNNING GEAR

Section 1	Trouble Shooting	159	Section 6	Shock Absorbers	169
2	Wheel Alignment	161	7	Steering Gear	170
3	Frames	163	8	Steering Linkage	175
4	Front Suspension	164	9	Wheels and Tires	178
5	Rear Suspension	168	10	Hubs and Bearings	181

CHAPTER IV—POWER STEERING

Section 1	Trouble Shooting	183	Section 4	Pump and Fluid Reservoir Assembly	190
2	Inspection and Maintenance	186	5	Control Valve Assembly	194
3	Power Steering System Operation	187	6	Power Cylinder Assembly	200
			7	Steering Linkage	202

CHAPTER V—BRAKES

206	Section 5	Brake Drums	213
207	6	Vacuum Booster	214
208	7	Parking Brakes	216
212			



Part THREE—ELECTRICAL AND ACCESSORIES

CHAPTER I—GENERATING SYSTEM AND BATTERY

	Page		Page		
Section 1	Trouble Shooting	217	Section 3	Generator Regulator	226
2	Generator	221	4	Battery	232

CHAPTER II—STARTING SYSTEM

Section 1	Trouble Shooting	235	Section 3	Starter Drive	244
2	Starter and Circuit	238			

CHAPTER III—LIGHTING SYSTEM, HORNS, AND INSTRUMENTS

Section 1	Trouble Shooting	245	Section 3	Horns	252
2	Lighting System	247	4	Instruments	253

CHAPTER IV—ACCESSORIES

Section 1	Trouble Shooting	257	Section 4	Windshield Wiper	268
2	Radio	260	5	Miscellaneous Accessories	269
3	Heater	265			

Part FOUR—BODIES

CHAPTER I—BODY CONSTRUCTION AND MAINTENANCE

Section 1	Construction Details and Sealer Application	271	Section 4	Fibre Glass Repair—Thunderbird Hardtop	281
2	Body Alignment	278	5	General Body Maintenance	282
3	Quarter Panel Repair	279	6	Paint Refinishing	284

CHAPTER II—TRIM, UPHOLSTERY, AND WINDOW GLASS

Section 1	Door and Quarter Trim Panels	289	Section 4	Door Glass and Regulator Replacement	296
2	Headlining Replacement	292	5	Door Glass Adjustments	299
3	Ventilator and Division Bar	294	6	Quarter Glass	303
			7	Windshield and Rear Window	307

CHAPTER III—REMOVABLE SHEET METAL ASSEMBLIES

Section 1	Door Replacement and Alignment	313	Section 5	Grille and Hood	324
2	Door Locking Mechanism	317	6	Hood Alignment and Lock Adjustment	326
3	Luggage Compartment Door Replacement and Alignment	320	7	Thunderbird Grille and Hood	328
4	Luggage Compartment Door Locking Mechanism	323	8	Front Fenders	329

CHAPTER IV—POWER INSTALLATIONS AND SPECIAL ITEMS

Section 1	Power Windows	331	Section 4	Thunderbird Top Adjustments	347
2	Power Seats	337	5	Care of Country Squire Paneling	349
3	Convertible Top	342	6	Crown Victoria Transparent Top	350

Part FIVE—MAINTENANCE AND SPECIFICATIONS

CHAPTER I—MAINTENANCE

Section 1	Preventive Maintenance	353	Section 2	Lubrication	355
-----------	------------------------	-----	-----------	-------------	-----

CHAPTER II—SPECIFICATIONS

Section 1	Wheels and Tires	357	Section 8	Cooling	363
		357	9	Fuel System	363
		358	10	Generating System	364
		358	11	Starting System	364
		359	12	Ignition	364
		360	13	Fuse and Bulb Chart	365
		362	14	Paint	365
			15	Tools and Equipment	366



Part ONE

POWER PLANT

Chapter

I

General Engine Overhaul, Inspection, and Repair

Section	Page
1 Trouble Shooting	5
2 Tune-Up	8
3 Engine Removal and Installation	10
4 Intake and Exhaust Manifolds	14
5 Rocker Mechanism, Cylinder Head, Valves, Valve Lash Adjustment, and Valve Timing	15
6 Timing Chain, Sprockets, and Camshaft	20
7 Flywheel, Crankshaft, and Main Bearings	22
8 Cylinder Block, Pistons, Piston Rings, and Connecting Rods and Bearings	25
9 Oil Pan and Oil Pump	29
10 Exhaust System	30

Trouble shooting; tune-up; the cleaning, inspection, and repair of component parts; and overhaul instructions are covered in this chapter.

The cleaning, inspection, repair, and overhaul instructions apply only after the parts have been removed from the engine, or in the case of a complete overhaul

after the engine has been disassembled.

To completely disassemble or assemble an engine, follow all the removal or installation instructions contained in the applicable engine chapter. If it is only desired to remove or install an individual part, refer to the applicable section.

I. TROUBLE SHOOTING

Trouble shooting is the application of a definite procedure, in a logical sequence, to locate and eliminate the cause of trouble in a particular system or unit. When trouble shooting, first look for the obvious causes of trouble, such as; an empty gas tank, a wet or cold engine, loose or disconnected wiring, or any other item that may cause a temporary defect.

The various factors that affect power plant operation are outlined in this section.

a. Engine.

Poor engine performance can be attributed to the engine or to forces on the car that tend to retard its motion.

For example, dragging brakes can cause the engine to work harder which will result in poor performance.

Engine performance depends on proper fuel distribution, correctly timed ignition, normal and uniform compression, and an unobstructed flow of exhaust gases.

Engine troubles, their causes, and remedies are discussed under appropriate headings.

(1) **ENGINE WILL NOT CRANK.** If the starter does not turn the engine over, or turns it over too slowly, there are a defective battery or a defective starter. After making the following checks in the order indicated:

(a) **CHECK THE BATTERY.** Try the horn or lights. If they do not operate properly, test the battery. Recharge or replace the battery as necessary.

(b) **CHECK THE BATTERY CABLES.** Check for loose or corroded connections at the starter, relay, battery, and ground. Clean, tighten or replace them as necessary.

(c) **CHECK THE STARTER RELAY CIRCUIT.** The relay contact surfaces seldom become so badly burned that they will prevent the starter from cranking the engine. However, other wiring may be at fault. Repair as necessary. Refer to Part THREE, "Electrical and Accessories."

(d) **CHECK THE STARTER OR STARTER DRIVE.** If the above components are not at fault, the trouble is probably in the starter or starter drive. If the starter is running, but not engaging the flywheel, remove the starter and make the necessary repairs to the starter drive. In rare cases, the starter drive may lock up with the flywheel. This can be corrected by loosening the starter and releasing the starter drive. If the starter does not operate, remove it and make the necessary repairs.

(2) **ENGINE CRANKS, BUT WILL NOT START.** The trouble probably lies in either the ignition system or the fuel system. The following test will determine which system is at fault:

Remove the ignition wire from one spark plug, and

insert a piece of proper sized metal rod so it protrudes from the insulator. With the ignition on and the starter turning the engine over, hold the end of the rod approximately 3/16 inch from the block.

CAUTION: On Fordomatic equipped cars, make sure the selector lever is in "N."

If there is no spark, or if there is a weak spark, follow steps "a" or "b" whichever is applicable. If there is a good spark, proceed with step "c."

(a) **NO SPARK.** Follow the steps below to determine the cause, and make the necessary repairs or replacements.

(1) Pull the coil wire from the top of the distributor. Hold the wire 3/16 inch from the cylinder head, and with the ignition on and the engine turning over, check for a spark.

CAUTION: On Fordomatic equipped cars, make sure the selector lever is in "N."

If a good spark is obtained, the trouble lies in either the distributor cap, rotor, or spark plug wires. Make sure these components are clean, dry, and not defective. Make repairs or replacements as necessary.

(2) If there was no spark in (1), clean the coil tower socket, or replace the high tension wire between the coil and distributor, then repeat the check. If a weak spark exists, the points are probably arcing. Test the condenser and replace it if necessary. Adjust the points. If a weak spark persists, test the coil, and replace it if necessary.

(3) If there was no spark in (2), remove the distributor cap, and see if the points are "breaking" and if an electrical spark occurs at the points. Adjust or replace the points as necessary. If there is a spark at the points; install a "jumper" between the "DIST" terminal of the coil and the distributor, then check for a spark at the points. If there is a spark, replace the coil to distributor primary wire. If there is no spark, crank the engine until the points are closed, then install a "jumper" on one of the primary coil terminals and check for a spark at the other terminal. Replace the coil if there is now a spark. If there is no spark, install a "jumper" between the battery and the battery terminal of the coil, then check for a spark at the points. If a spark exists, the ignition switch or switch to coil wiring is defective and must be repaired or replaced.

(b) **WEAK SPARK.** Perform the following checks in the order listed:

(1) The battery may be weak. Test the battery, then charge or replace it if necessary.

(2) Remove the distributor cap, and adjust, clean, or replace the points. Check for pitted points. If the points are pitted, they should be replaced. If the points are improperly adjusted, they should be properly adjusted.

(3) Remove the distributor cap, and check the points, rotor, and fully

seated in the terminals. Replace any damaged or corroded wires.

(4) If the weak spark persists, test the coil, and replace it if necessary.

(c) **GOOD SPARK.** If there is a good spark, perform the following fuel system checks in the order given.

(1) Check the fuel supply at the fuel tank.

(2) Check to see if fuel is reaching the carburetor. Remove the air cleaner, and look down the carburetor throat while working the throttle by hand several times. Each time the throttle is actuated, fuel should spurt from the accelerator pump discharge nozzle. If there is fuel at this point, the engine is probably flooded or there is water in the fuel system. If no fuel is observed at this point, disconnect the carburetor inlet line at the carburetor. Using a suitable container to catch the fuel, crank the engine to see if fuel is reaching the inlet fitting. If fuel is reaching the inlet fitting, the trouble is in the carburetor. Repair the carburetor as necessary. If no fuel is reaching the inlet fitting, the trouble is in the fuel pump or the fuel pump inlet line is clogged.

NOTE: Check the flexible fuel pump inlet line for a collapsed condition.

Remove the fuel tank filler cap, then disconnect the fuel pump inlet line at the pump. Blow air into the line to remove any obstructions. Connect the line and try to start the engine. If the engine does not start, check the fuel pump pressure, then repair or replace the pump as necessary.

(3) **ENGINE STARTS BUT FAILS TO KEEP RUNNING.** Check the fuel system first. The ignition system sometimes can cause trouble, but it is usually after the engine has run for some time and is at operating temperature.

(a) Check the fuel supply at the tank.

(b) Try to start the engine. If the engine will operate with constant foot throttle, adjust the idle speed and check the choke adjustment.

If it will not operate with constant foot throttle, check the fuel system as outlined in (2) (c).

(c) If the fuel system is operating correctly and the engine still stalls, it may be due to the coil or condenser breaking down under operating temperature. Check these components, and replace them as necessary.

(4) **ENGINE CONTINUALLY MISSES AT IDLE.** When the engine continually misses on the same cylinders, the fault generally lies in the ignition system.

(a) Isolate the miss by pulling one spark plug cable at a time from the plugs. Remove the plugs, then clean, inspect, and adjust them. Replace those that are badly fouled or burned.

(b) Check the spark plug wires for signs of deterioration and corrosion and replace them as necessary.

(c) Remove the distributor cap and rotor, then clean, inspect, and replace them as necessary.

(d) If the above steps do not correct the condition, check the compression to determine if it is satisfactory and check the intake manifold passages for obstructions.

(5) **ENGINE MISSES ERRATICALLY AT IDLE.** A miss of this type may be caused by a combination of things. Check the following in sequence:

(a) Carburetor, including choke operation, idle mixture setting, and fuel level.

(b) The ignition system, starting with the spark plugs. Make the necessary repairs.

(c) The vacuum lines and fittings for leaks. Make any necessary repairs.

(d) Valve operation. Perform a compression test if the miss persists. Repair the engine as necessary.

(6) **ENGINE MISFIRES OR HESITATES ON ACCELERATION.** This malfunction is usually a combination of faults in the ignition and fuel system, but also can be caused by the exhaust system. Check the following in sequence.

(a) Check the operation of the exhaust gas control valve. If it is sticking, free it up or replace it as necessary.

(b) Check the paint on the intake manifold heat riser passage. If the paint is not burned off, the passage may be obstructed preventing the carburetor from properly vaporizing the fuel.

(c) Remove the spark plugs. Inspect, clean, and adjust the gap. Replace any plugs that are defective or lead-fouled.

(d) Remove the distributor cap, and check the point gap, distributor shaft clearance, condition of the cam lobes, and the points. Make the necessary repairs or replacements. Check the high tension wiring for signs of deterioration, and make replacements or repairs as necessary.

(e) Check the coil and condenser. Replace them if they are defective.

(f) Check the fuel pump pressure and adjust the carburetor fuel level. Check the accelerator pump action and linkage.

(g) If the problem still persists, perform a compression test, and check the valve lash. Check the valve spring rates and assembled height. Make repairs or replacements as necessary.

(7) **ENGINE DOES NOT DEVELOP FULL POWER.** Lack of power is usually caused by poor compression. However, some preliminary checks should be made. Make sure the throttle opens all the way, and the choke remains open. After preliminary checks are made, perform the following operations if the trouble has not been located:

(a) Check the compression. This will indicate whether the engine is compressing properly.

(b) If the compression is within limits, check the valve lash, valve timing and distri-

(c) If the compression and the ignition system are satisfactory, check the fuel system, including carburetion and fuel pump pressure.

(d) If the problem still exists, a check of mechanical components must be made. Check the valve lash, cam lobe lift, and valve timing. Make the necessary repairs.

b. Fuel System.

The fuel system consists of the fuel tank, fuel pump, carburetor, and connecting lines. Dirt and other foreign material are a major source of fuel system problems. Keep all components as clean as possible.

(1) **EXCESSIVE FUEL CONSUMPTION.** Faulty carburetion is usually responsible for excessive fuel consumption. However, the following preliminary checks should be made:

Check for fuel leaks in the system. Check choke operation and adjustment, and make certain the accelerator linkage is free. Check to see if the brakes are dragging. Adjust the carburetor.

(a) Verify the complaint with test equipment installed in the car. Show the customer how improper operation of the car will affect fuel consumption.

(b) If the test shows fuel consumption to be excessive, rebuild the carburetor. Since poor carburetion is usually a combination of internal malfunctions, it is usually not advisable to try to repair only one system in the carburetor. Time will be saved by a complete carburetor overhaul.

(2) **CARBURETOR FLOODS.** Make a visual inspection of the carburetor for leaking gaskets or casting defects. Tap the carburetor bowl. If the flooding stops, the inlet needle was held open by foreign material. If the flooding persists, follow the steps below:

(a) Remove the air cleaner and check the choke operation.

(b) Check the fuel level, the condition of the carburetor float, and the fuel inlet needle and seat. Replace any defective parts.

(c) Check fuel pump pressure. If the pressure is excessive, the pump was forcing fuel past the inlet needle and the pump should be rebuilt or replaced.

c. Cooling System.

The cooling system is thermostatically controlled to regulate engine operating temperature and provide for a short engine warm-up period.

(1) **ENGINE OVERHEATS.** Usually, engine overheating is the result of insufficient coolant supply. Check the coolant level first. Make certain that the cause of trouble is not anti-freeze evaporation.

(a) If the supply is low, check for leaks in the cooling system, then make the necessary repairs.

(b) Check the water pump belt for proper tension and adjust it if it is loose.



(c) Inspect the radiator fins for obstructions (bugs, dirt, etc.). Clean it if it is clogged.

(d) Using a thermometer in the radiator, check the gauge reading for accuracy.

NOTE: *Inaccurate readings are sometimes caused by insufficient clearance between the head casting and the temperature sending unit element. Make repairs or replacements as necessary.*

(e) Check the thermostat for proper operation and heat range. If it is defective or of the wrong heat range, replace it. Make sure the thermostat is correctly installed.

(f) Check the ignition timing and adjust it if necessary.

(g) Check the radiator for proper flow. Flush it if necessary.

(h) Remove the water pump and check for a defective impeller or a water passage obstruction. Make repairs or replacements as necessary.

(i) Check the cylinder head(s) for water passage obstructions. Clean out the passages or replace the head(s) if necessary.

(j) Check the cylinder block for water passage obstructions. Clean out the passages or replace the block if necessary.

(2) ENGINE FAILS TO REACH NORMAL OPERATING TEMPERATURE. Generally this is caused by the thermostat sticking or being of the wrong heat range. Check the thermostat first. If the engine still does not reach operating temperature, check the gauge and sending unit with a thermometer installed in the radiator. Replace any defective parts.

2. TUNE-UP

Regular maintenance and inspection services are necessary for proper car operation. In addition, to maintain satisfactory performance, a periodic engine tune-up should be made.

A reliable type of engine test equipment should be used to perform the tests. As the checks and tests are made, make a visual inspection of the wiring, vacuum hoses, cooling system hoses, heater hoses, etc.

a. Minor Tune-Up.

Perform the following operations in the order given.

(1) INSPECT IGNITION WIRES, BATTERY CABLES, AND CHECK THE CONDITION OF THE BATTERY. Inspect all ignition wires for worn or damaged insulation. Make sure the wires are firmly seated in the distributor cap and that the terminals and terminal sockets are free from corrosion.

Inspect the battery case for cracks and leaks. Make a battery capacity test. If unsatisfactory, make a battery charge test. If the charge is low, recharge the battery. Inspect the battery cable connections for corrosion, and clean them if necessary. Brush the cable connectors with grease to retard further corrosion, then tighten the connectors securely.

(2) TEST CYLINDER COMPRESSION. Be sure the battery is good. Operate the engine until normal operating temperature is reached. Turn the ignition switch off. Remove all spark plugs.

Set the throttle in the wide open position and be sure the choke is wide open. Install a compression gauge in number 1 cylinder. Crank the engine until the gauge reaches its maximum reading and record the reading. Note the number of strokes required to reach maximum on each cylinder, and the number of strokes as was recorded on number 1 cylinder.

A variation of ± 10 pounds from specified pressure is satisfactory. However, the compression of all cylinders should be uniform within 10 pounds.

A reading of more than 10 pounds above normal indicates carbon or lead deposits in the cylinder.

A reading of more than 10 pounds below normal indicates leakage at the head gasket, rings, or valves.

A low even compression in two adjacent cylinders indicates a head gasket leak. This should be checked before condemning the rings or valves.

To determine whether the rings or the valves are at fault, put a tablespoon of heavy oil on the piston, and repeat the compression test. The oil will temporarily seal leakage past the rings. If the same reading is obtained, the rings are satisfactory, but the valves are leaking. If the compression has increased 10 pounds or more over the original reading, it indicates there is leakage past the rings.

During a compression test, if the pressure fails to climb steadily and remains the same during the first two successive strokes, but climbs higher on the succeeding strokes, or fails to climb during the entire test, it indicates a sticky or stuck valve.

(3) CLEAN, ADJUST, AND INSTALL THE SPARK PLUGS. Sandblast the spark plugs, wipe the porcelain clean, file the electrode tips flat, and adjust the spark gap. Test the plugs in an approved spark plug tester. Inspect the plugs for broken or chipped porcelain and badly burned electrodes. Replace all defective plugs. Install the spark plugs and tighten them to the specified torque.

(4) CHECK THE DISTRIBUTOR. Remove the distributor cap and rotor. Inspect the breaker points for pitting and burning. Replace defective points. Clean and install the distributor cap and rotor.

(5) CHECK IGNITION TIMING. Disconnect the dis-



tributor vacuum line. Operate the engine at idle speed. Check the timing with a timing light and make the necessary adjustments. Connect the distributor vacuum line.

(6) **CHECK MANIFOLD VACUUM AND ADJUST CARBURETOR IDLE.** Check the manifold vacuum at the specified idle speed.

If the vacuum is lower than specified, check for leakage at the vacuum lines and intake manifold. Check the carburetor idle adjustment.

If the vacuum is still below normal or is erratic, it is an indication of bad rings, sticky valves, weak valve springs, or a head gasket leak.

Set the engine idle speed and the carburetor idle fuel adjustment as outlined in Chapter IV.

(7) **CLEAN THE AIR CLEANER AND THE FUEL FILTER.** Clean the air cleaner, and oil the element. If the air cleaner is the oil bath-type, fill to the indicated level with engine oil of the specified viscosity.

On passenger cars, remove and clean the fuel pump bowl. Install a new filter element.

On Thunderbirds, clean the fuel line filter. Install a new filter element.

(8) **CHECK THE DEFLECTION OF THE DRIVE BELTS.** Check the deflection of all drive belts (fan, air conditioning, and power steering). Make the necessary adjustments.

b. Major Tune-Up.

Perform the following operations in the order given.

(1) **BATTERY.** Remove the cables from the battery. Clean the battery terminals and cable connectors. Inspect the battery case for cracks and leaks. Make a battery capacity test. If unsatisfactory, make a battery charge test. If the charge is low, recharge the battery. Replace deteriorated connectors and cables that have worn insulation. Brush the cable connectors with grease to retard further corrosion. Connect the cables to the battery.

(2) **CHECK THE GENERATOR AND REGULATOR.** Follow the procedures outlined in Part THREE, "Electrical and Accessories."

(3) **TEST SPARK INTENSITY.** Determine if the spark from each plug wire will jump a $\frac{3}{16}$ inch gap, as follows:

Remove one spark plug wire, and install a terminal adapter in the wire terminal. Hold the end of the adapter approximately $\frac{3}{16}$ inch from the cylinder head. Run the engine at idle speed. The spark should jump regularly. Repeat the test on each lead.

at all spark plugs, rotor or cap, inter-
e external primary

If the spark is unsatisfactory at some, but not all of the spark plug wires, the trouble is in the wire itself, the wire is not seated in the housing socket, or the distributor cap is corroded.

(4) **TEST CYLINDER COMPRESSION.** Follow the procedure under "a. Minor Tune-Up."

(5) **CLEAN, ADJUST, AND INSTALL SPARK PLUGS.** Sandblast the spark plugs, wipe the porcelain clean, file the electrode tips flat, and adjust the gap. Test the plugs in an approved tester. Inspect the plugs for broken or chipped porcelain and badly burned electrodes. Replace all defective plugs. Install the plugs and tighten them to the specified torque.

(6) **CHECK MANIFOLD BOLT TORQUE.** Tighten the intake and exhaust manifold bolts and nuts to 23-28 foot-pounds torque.

(7) **TEST COIL AND CONDENSER.** If the spark intensity (3) is satisfactory, it will not be necessary to test the coil and condenser. However, if the spark is not satisfactory, test these parts on a test unit to determine which one is defective. Follow the instructions of the test unit manufacturer.

(8) **INSPECT BREAKER POINTS AND TEST THE DISTRIBUTOR.** Inspect the distributor points for pits, excessive metal transfer, and burned spots.

Test the vacuum advance and make adjustments, repairs, or replacements as required. Set the point gap to specifications. After setting the gap, check the point dwell. If the dwell angle is not to specifications, the distributor cam is worn or the point assembly is defective. Replace all defective parts. Lubricate the distributor cam lightly with distributor cam lubricant.

(9) **CLEAN AND INSPECT THE DISTRIBUTOR CAP.** Inspect the cap for cracks or other damage. Remove all corrosion from the terminal housing sockets.

(10) **CHECK IGNITION TIMING.** Disconnect the vacuum line between the distributor and carburetor. and operate the engine at idle speed. Check the timing with a timing light and make the necessary adjustments. Connect the distributor vacuum line after completing the adjustment and check ignition advance as the engine is accelerated.

(11) **CHECK AND ADJUST VALVE LASH.** Check and adjust the valve lash after the engine is thoroughly warmed up.

(12) **TEST MANIFOLD VACUUM.** Check the manifold vacuum at the specified idle speed.

If the vacuum is lower than specified, check for leakage at the vacuum lines and intake manifold. Check the carburetor idle adjustment.

If the vacuum is still below normal or is erratic, it is an indication of bad rings, sticky valves, weak valve springs, or a leaking head gasket. If this condition exists, it should be reported to the customer.



(13) **TEST FUEL PUMP PRESSURE AND CAPACITY.** The static pressure should be 3.5-5.5 p.s.i. at 500 r.p.m. The capacity should be 1 pint in 30 seconds at 500 r.p.m.

(14) **TEST BOOSTER PUMP VACUUM.** The booster pump vacuum should be 10.0 inches of mercury at 500 r.p.m. The vacuum should not drop rapidly when the engine is stopped.

(15) **INSPECT AND CLEAN THE FUEL FILTER.** On passenger cars, remove and clean the fuel pump bowl. Install a new filter element.

On Thunderbirds, clean the fuel line filter. Install a new filter element.

(16) **CLEAN THE CARBURETOR.** Disassemble and clean the carburetor. Set the fuel level, and check the accelerator pump operation.

(17) **CLEAN THE AIR CLEANER.** Clean the air cleaner and the element. If the air cleaner is the oil bath-type, fill to the indicated level with engine oil of

the specified viscosity.

(18) **ADJUST CARBURETOR IDLE.** Set the engine idle speed and the carburetor idle fuel adjustment as outlined in Chapter IV.

(19) **EXHAUST ANALYSIS.** On dual exhaust equipped cars, connect the analyzer tube to the left muffler outlet pipe.

Inasmuch as there are several types of analyzers, follow the instructions of the manufacturer.

(20) **CHECK THE DEFLECTION OF THE DRIVE BELTS.** Check the deflection of all drive belts (fan, air conditioning, and power steering). Make the necessary adjustments.

(21) **ROAD TEST.** Road test the car as a final check on the work performed. Also, notice the performance of the transmission, axle, brakes, and any optional accessories. Recommend any additional service required when the car is delivered to the owner.

3. ENGINE REMOVAL AND INSTALLATION

Separate procedures are given for the conventional passenger car and the Thunderbird.

a. Conventional Passenger Car.

The following procedures apply to all conventional passenger cars. Differences in the procedures peculiar to cars equipped with an 8 or 6-cylinder engine are noted when they exist.

The procedures given are for the engine only, without the transmission attached. Engine compartment tolerances make it impractical to remove or install the engine with the transmission attached.

(1) **REMOVAL.** If the car is equipped with a standard or overdrive transmission, follow steps (a) and (c). If the car is equipped with Fordomatic, follow steps (b) and (c).

(a) **STEPS PECULIAR TO A STANDARD OR OVERDRIVE TRANSMISSION.** Disconnect the clutch release spring. Remove the screws retaining the equalizer bar support to the flywheel housing, then remove the support and bushing. Disconnect the accelerator linkage at the manifold bell crank. Remove the two flywheel housing upper bolts. Remove the flywheel housing cover, support the transmission with a jack, then remove the remaining flywheel housing bolts.

(b) **STEPS PECULIAR TO FORDOMATIC.** Disconnect the transmission throttle linkage at the cross shaft, and tie the linkage to the dash panel. Remove the idler arm. Fold back the floor mat, remove the two rubber housing to engine car and position with a jack, then ng to engine bolts.

Remove the converter housing lower access cover, then turn the flywheel till the flywheel drive plate is in position to remove the three bolts. Turn the flywheel 180°, then remove the other three bolts.

CAUTION: *After the bolts are removed from the converter drive plate, turn the drive plate 90° so the flex plates will not catch on the converter housing when the engine is removed.*

Drain the transmission. Remove the bracket that secures the transmission oil level indicator tube to the engine. Disconnect the tube at the transmission oil pan, then remove the tube assembly. Remove the transmission control linkage splash shield from the cylinder block, then remove the oil filter.

(c) **ENGINE REMOVAL.** Remove the hood. Drain the cooling system and the crankcase. Remove the heater hoses. Remove the heater inlet duct and the heater blower motor.

Remove the radiator upper and lower hoses, then remove the radiator. Remove the fan. Disconnect the battery ground cable at the cylinder block, and the flex fuel line at the fuel pump.

Disconnect the windshield wiper vacuum hose, temperature sending unit wire, and the oil pressure sending unit wire. Disconnect the primary wire at the coil. Remove the starter cable at the starter, then remove the starter. Disconnect the ground cable from the rear of the engine. Remove the air cleaner, then tape the air horn closed. Disconnect the choke cable at the carburetor. Disconnect the accelerator linkage.

Disconnect the muffler inlet pipes at the exhaust manifold.



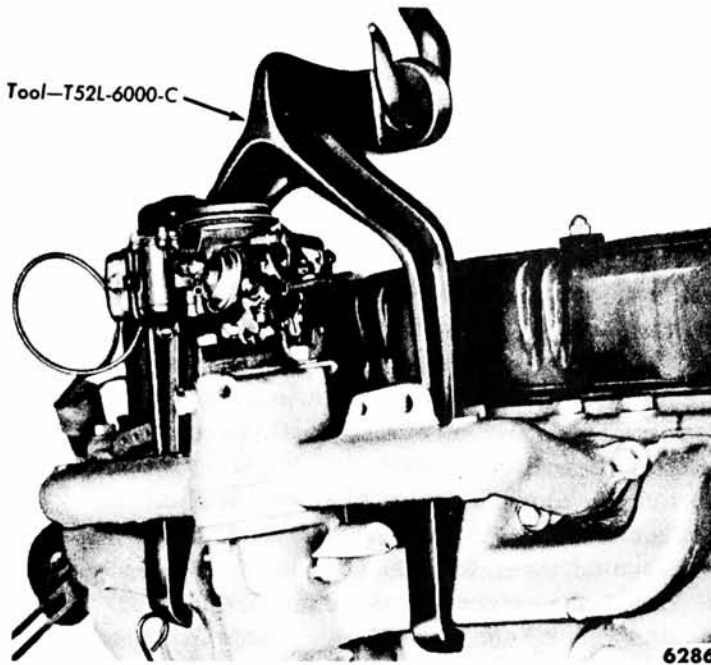

Fig. 1—Lifting Hook—6-Cylinder Engine

Attach the engine lifting hook(s) (fig. 1 or 2). Remove the right and left front splash aprons.

On 8-cylinder engines, remove the retainer and lower insulator from the engine front steady rest.

On 6-cylinder engines, loosen the two engine front steady rest to spacer bolts. Raise the car and position safety stands.

On 8-cylinder engines, remove the engine left insulator. Remove the cap screws from the engine right insulator at the engine.

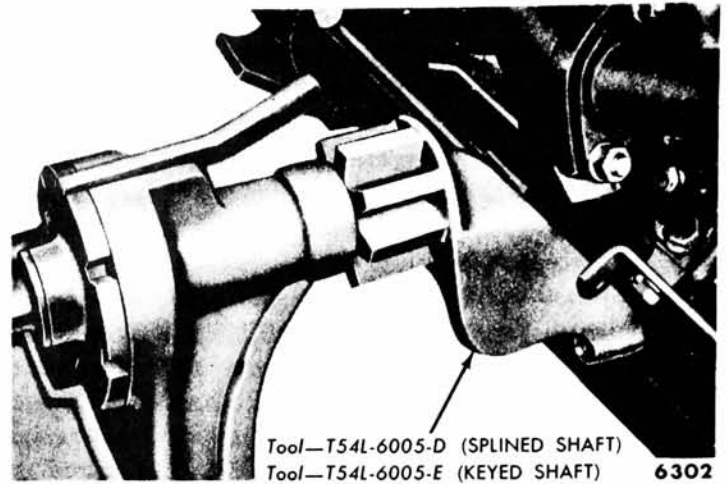

Fig. 3—Engine Mount—8-Cylinder Engine

On 6-cylinder engines, remove the left insulator to bracket bolts at the insulator, and the right bracket bolts at the engine.

Raise the engine slightly, then carefully pull it from the transmission. Carefully lift the engine out of the engine compartment. Do not let the engine swing against the grille.

Install the engine on a work stand (fig. 3 or 4).

(2) **INSTALLATION.** If the car is equipped with a standard or overdrive transmission, follow steps (a), (b), and (d). If the car is equipped with Fordomatic, follow steps (a), (c), and (d).

(a) **ENGINE INSTALLATION.** Install the appropriate engine lifting hook, then remove the engine from the work stand.

CAUTION: On Fordomatic equipped cars, make sure the flywheel drive plate is turned so the flex plate will not catch on the converter housing.

Lower the engine carefully into the engine compartment.

On 8-cylinder engines, lower the engine until the oil pump to oil pan line clears the engine left support.

Start the transmission main drive gear into the clutch

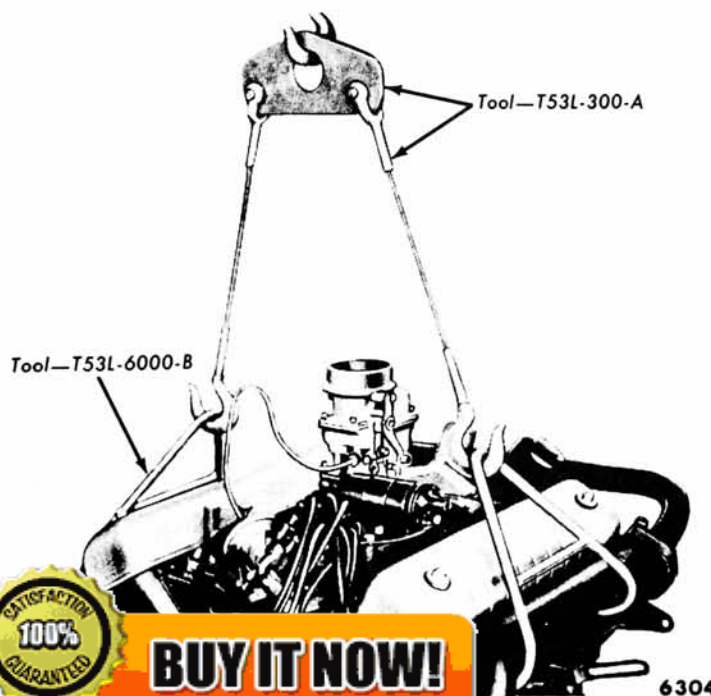

Fig. 2—Lifting Hook—8-Cylinder Engine

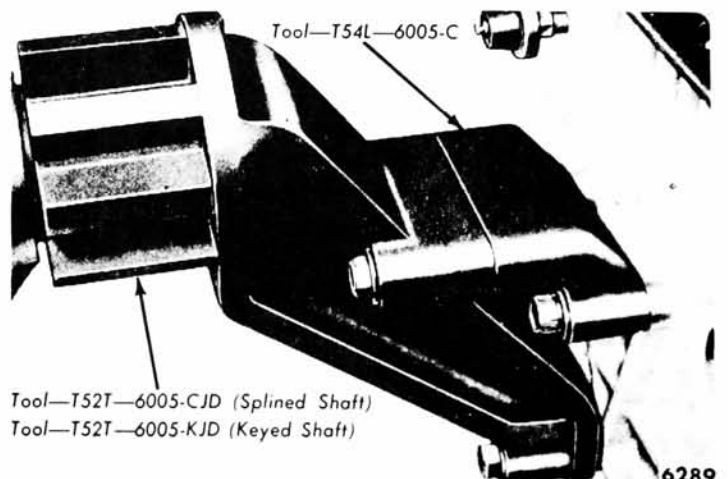

Fig. 4—Engine Mount Adapter—6-Cylinder Engine

100% SATISFACTION GUARANTEED

BUY IT NOW!

Click Here To Order

PayPal | American Express | Discover | MasterCard | VISA

disc. On Fordomatic units, start the converter pilot into the crankshaft.

NOTE: *On standard or overdrive units, it may be necessary to adjust the position of the transmission with relation to the engine if the transmission input shaft will not enter the clutch disc. If the engine "hangs up" after the shaft enters, turn the crankshaft slowly (with the transmission in gear) until the shaft splines mesh with the clutch disc splines.*

Make sure the studs on the manifolds of both the 6 and 8-cylinder engines are aligned with the holes in the muffler inlet pipe(s) and the dowels in the block engage the holes in the clutch housing (on Fordomatic units the block dowels must engage the holes on the converter housing).

NOTE: *Level the engine crosswise in relation to the frame before installing the mounting bolts or the steady rest.*

On the 6-cylinder engine, install the left insulator to bracket lockwashers and bolts and the right bracket to engine lockwashers and bolts. Tighten the insulator to bracket bolts to 45-50 foot-pounds torque. Tighten the engine front steady rest to spacer bolts to 30-35 foot-pounds torque.

On the 8-cylinder engine, align the holes in the engine left support insulator with the mounting holes in the block, then install the insulator to engine bolts and the frame to insulator lockwashers and nuts. Install the right insulator to engine lockwashers and bolts. Tighten the insulator to engine bolts to 45-50 foot-pounds torque and the frame to insulator nuts to 50-60 foot-pounds torque. Install the engine front steady rest lower insulator and retainer. Tighten the retainer bolt to 23-28 foot-pounds torque. Install the right and left front splash aprons.

Connect the manifold(s) to the muffler inlet pipe(s). Install the starter, then connect the starter cable (except Fordomatic). Connect the ground cable to the rear of the engine, the temperature sending unit and oil pressure sending unit wires, the generator wires, and the ignition switch wire to the coil. Connect the ignition switch wire to the engine clips. Connect the accelerator linkage and the choke wire (6-cylinder engine).

Connect the windshield wiper line and the fuel pump vacuum line. Connect the fuel pump flexible line. Install the fan assembly, then adjust the fan belt.

Install the radiator and connect the radiator hoses. Connect the battery ground cable to the engine. Remove the tape from the carburetor air horn and install the air cleaner. Install the heater blower motor and the

let duct, then connect the heater hoses.

system and the

DRIVE TRANSMIS-
lizer bar support,

then install the support on the flywheel housing. Install the transmission to flywheel housing bolts, and tighten them to 40-50 foot-pounds torque. Install the flywheel housing cover. Connect the clutch release spring.

Remove the jack supporting the transmission. Check the clutch pedal free travel ($1\frac{1}{8}$ - $1\frac{3}{8}$ inches) and adjust it if necessary.

(c) **CONNECT FORDOMATIC TRANSMISSION.** Install the two converter housing to engine lower bolts, and tighten them to 40-45 foot-pounds torque.

NOTE: *Tighten the bolts slowly and evenly to avoid binding on the dowel pins.*

Install the two converter housing to engine upper bolts, and tighten them to 40-45 foot-pounds torque. Install the floor pan plugs. Align the flywheel and drive plate holes with the converter, then install the six bolts, and tighten them to 25-28 foot-pounds torque.

Install the starter, and tighten the bolts to 15-20 foot-pounds torque. Install the transmission oil level indicator tube assembly. Install the idler arm and bracket. Tighten the idler arm bracket nuts to 28-43 foot-pounds torque. Install the converter housing lower access covers.

Install and connect the throttle linkage and make the necessary linkage adjustments. Remove the jack supporting the transmission. Fill the transmission with Automatic Transmission Fluid—Type A, following the recommended procedure.

(d) **CHECK ENGINE FOR OIL OR COOLANT LEAKS.** Run the engine at fast idle and check all gaskets and hose connections for leaks.

b. Thunderbird.

On Fordomatic equipped Thunderbirds, the engine may be removed with or without the transmission attached.

(1) **REMOVAL.** To remove the engine from a Thunderbird equipped with a standard or overdrive transmission, follow steps (a) and (c). To remove the engine from a Thunderbird equipped with Fordomatic, follow steps (b) and (c). To remove the engine and Fordomatic as an assembly, follow steps (c) and (d).

(a) **STEPS PECULIAR TO A STANDARD OR OVERDRIVE TRANSMISSION.** Disconnect the clutch release spring. Remove the screws retaining the equalizer bar support to the flywheel housing, then remove the support and bushing. Remove the two flywheel housing upper bolts. Remove the flywheel housing cover, support the transmission with a jack, then remove the remaining flywheel housing bolts.

(b) **STEPS PECULIAR TO FORDOMATIC.** Disconnect the transmission throttle linkage at the cross shaft, and tie the linkage to the dash panel. Remove the idler arm bracket.

Jack up the front of the car and position safety stands.

Support the transmission with a jack, then remove the converter housing to engine bolts. Remove the converter housing lower access cover, then turn the flywheel till the flywheel drive plate is in position so the three bolts can be removed. Turn the flywheel 180°, then remove the other three bolts.

CAUTION: *After the bolts are removed from the converter drive plate, turn the drive plate 90° so the flex plates will not catch on the converter housing when the engine is removed.*

Drain the transmission. Remove the bracket that secures the transmission oil level indicator tube to the engine. Disconnect the tube at the transmission oil pan and remove the tube assembly. Remove the transmission control linkage splash shield.

(c) **ENGINE REMOVAL.** Remove the hood. Drain the cooling system and the crankcase. Remove the fan, then remove the radiator and shroud as an assembly. Remove the air cleaner. Disconnect the engine ground wire at the dash panel. Disconnect the battery ground cable at the engine and the battery to starter relay cable at the battery. Disconnect the vacuum pump line, and the fuel inlet at the fuel pump. Disconnect the starter cable at the starter solenoid, then remove the cable clamp at the dash panel. Disconnect the ignition switch to coil wire at the coil. Disconnect the two heater hoses. Remove the generator wires. Remove the wires from the oil pressure sending unit and the temperature sending unit. Remove the heater blower assembly. Disconnect the tachometer cable. Disconnect the accelerator rod, then disconnect the link bracket at the block (this bracket also serves as the ignition cable bracket).

Raise the car and position safety stands. Disconnect the exhaust pipes at the exhaust manifolds. Remove the engine front mount bolt, nut, and lower insulator. Remove the engine right and left steady rest bracket bolts at the engine, then turn the brackets to one side so the engine will clear them upon removal.

Remove the safety stands and lower the car. Install the engine lifting hooks (fig. 2). Raise the engine slightly, then carefully pull the engine from the transmission. Carefully lift the engine out of the engine compartment.

Install the engine on a work stand (fig. 3).

(d) **STEPS PECULIAR TO REMOVING THE ENGINE AND FORDOMATIC AS AN ASSEMBLY.** While the car is raised in step (c), perform the following additional operations:

Drain the transmission. Disconnect the shift control linkage at the transmission and the throttle control rod. Disconnect the speedometer cable. Remove the drive shaft with an extension housing and the drive shaft and extension housing assembly. Remove the transmission oil level indicator tube at the

transmission oil pan, then remove the tube assembly. Remove the engine rear mount bolt, raise the transmission, then remove the cross member that serves as the engine rear mount.

Remove the transmission jack and lower the car. Install the engine lifting hooks. Raise the engine slightly, then carefully pull the engine and transmission forward. Carefully lift the engine and transmission from the engine compartment.

(2) **INSTALLATION.** To install the engine in a Thunderbird equipped with a standard or overdrive transmission, follow steps (a), (b), (e), and (f). To install the engine only in a Fordomatic equipped Thunderbird, follow steps (a), (c), (e), and (f). To install the engine and Fordomatic as an assembly, follow steps (a), (d), (e), and (f).

(a) **ENGINE INSTALLATION.** Install the engine lifting hooks, then remove the engine from the work stand.

CAUTION: *On Fordomatic equipped cars, make sure the flywheel drive plate is turned so the flex plates will not catch on the converter housing.*

Lower the engine carefully into the engine compartment.

Start the transmission main drive gear into the clutch disc. On Fordomatic units, start the converter pilot into the crankshaft.

NOTE: *On standard or overdrive units, it may be necessary to adjust the position of the transmission with relation to the engine, if the input shaft will not enter the clutch disc. If the engine "hangs up" after the shaft enters, turn the crankshaft slowly (with the transmission in gear) until the shaft splines mesh with the clutch disc splines.*

Make sure the studs on the manifolds are aligned with the holes in the muffler inlet pipes, and the dowels in the block engage the holes in the clutch housing (on Fordomatic units the block dowels must engage the holes on the converter housing).

Raise the car and position safety stands. Install the engine front support lower insulator, bolt, lockwasher, and nut. Tighten the insulator mounting nut to 85-95 foot-pounds torque. Install the engine right and left steady rest bracket bolts, and tighten the bolts to 45-50 foot-pounds torque.

NOTE: *If the rod assembly adjustment of either steady rest was disturbed during engine removal, adjust the rod as outlined in step (e).*

Connect the exhaust pipes to the exhaust manifolds. Remove the safety stands and lower the car.

Connect the accelerator rod, then connect the accelerator link bracket to the block. Connect the tachometer cable. Install the heater blower assembly. Install the oil pressure sending unit and the temperature sending unit wires. Connect the generator wires. Connect the two heater hoses. Connect the ignition switch to coil

SATISFACTION 100% GUARANTEED

BUY IT NOW!

Click Here To Order

PayPal American Express Discover MasterCard VISA

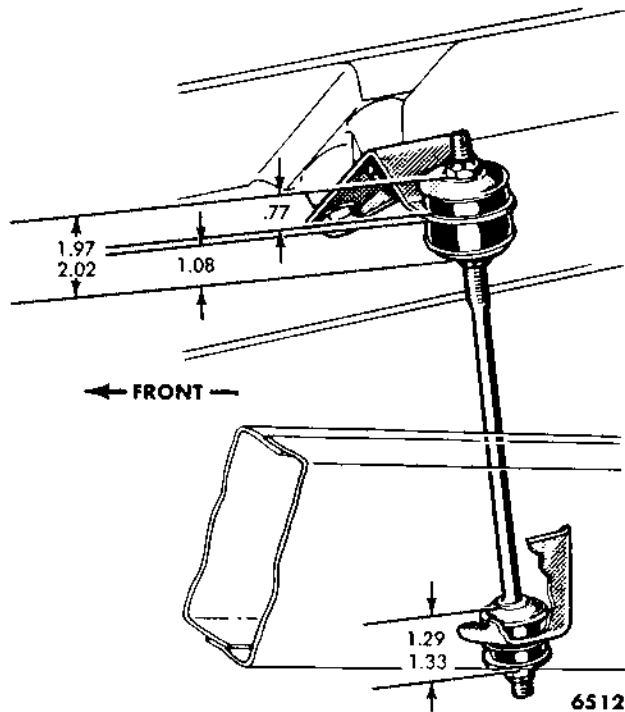

Fig. 5—Steady Rest Adjustment—Thunderbird

wire. Install the starter cable clamp on the dash panel, and connect the starter cable to the starter. Connect the windshield wiper line and the flexible fuel line. Connect the battery ground cable and the starter solenoid cable. Connect the engine ground wire. Install the air cleaner. Install the radiator and shroud, then install the fan. Install the hood. Fill the cooling system. Fill the crankcase with the correct quantity and grade of engine oil.

(b) **CONNECT STANDARD OR OVERDRIVE TRANSMISSION.** Install the bushings in the equalizer bar support, then install the support on the flywheel housing. Install the transmission to flywheel housing bolts, and tighten them to 40-50 foot-pounds torque. Install the flywheel housing cover. Connect the clutch release spring.

Remove the jack supporting the transmission. Check the clutch pedal free travel ($1\frac{1}{8}$ - $1\frac{3}{8}$ inches). Adjust the free play, if necessary.

(c) **CONNECT FORDOMATIC TRANSMISSION.** Install the two converter housing to engine lower bolts, and tighten them to 40-45 foot-pounds torque.

NOTE: *Tighten the bolts slowly and evenly to avoid binding on the dowel pins.*

Install the converter housing to engine bolts and tighten them to 40-45 foot-pounds torque. Align the flywheel and drive plate holes with the converter, install the six bolts, and tighten them to 25-28 foot-pounds torque.

Install the starter and tighten the bolts to 15-20 foot-pounds torque. Install the transmission oil filler tube assembly. Install the idler arm and bracket. Tighten the idler arm bracket nuts to 28-43 foot-pounds torque. Install the converter housing lower access covers.

Install and connect the throttle linkage, and make the necessary linkage adjustments. Remove the jack supporting the transmission. Fill the transmission with Automatic Transmission Fluid-Type A, following the recommended procedure.

(d) **INSTALL THE ENGINE AND FORDOMATIC AS AN ASSEMBLY.** While the car is raised in step (a), perform the following additional operations:

Jack up the transmission. Install the engine rear mount. Lower the transmission, then install the engine rear mount bolt. Install the converter air duct assembly. Install the transmission oil level indicator tube assembly. Remove the extension housing cap from the transmission, and install the drive shaft. Connect the speedometer cable. Connect the shift control linkage and the throttle control rod. Fill the transmission with Automatic Transmission Fluid-Type A, following the recommended procedure.

(e) **ENGINE STEADY REST ADJUSTMENT.** If the engine steady rests are not properly adjusted, the engine will be tilted and excessive engine vibration may result. It is good practice, therefore, to check the adjustment of the rod assemblies, at each engine installation. The dimensions are illustrated in fig. 5. If the rods are out of adjustment follow the procedure below:

With the engine steady rest support brackets in place and properly tightened (at the engine and chassis), loosen the rod lower and upper nuts on both steady rests. Let the engine seek its own level position. Turn the rod assembly lower nut, washer, and insulator of each steady rest up against the lower (chassis) support bracket. Tighten the lower nut to the dimension shown in fig. 5.

Turn the lower nut, washer, and insulator at the top of each rod assembly up against the engine support bracket. Tighten the nut to the dimension shown in fig. 5. Turn the upper nut, washer, and insulator at the top of the rod assembly down against the engine support bracket. Tighten the nut to the dimension shown in fig. 5. Check the adjustment of the top portion of the rod assembly by measuring the over-all dimension as indicated in fig. 5.

(f) **CHECK THE ENGINE FOR OIL OR COOLANT LEAKS.** Run the engine at fast idle and check all gaskets and hose connections for leaks.

100% SATISFACTION GUARANTEED

BUY IT NOW!

Click Here To Order

PayPal

MasterCard

DISCOVER

MasterCard

VISA

AKE AND EXHAUST MANIFOLDS

the outside of the

exhaust manifolds. Clean the mating surfaces and check

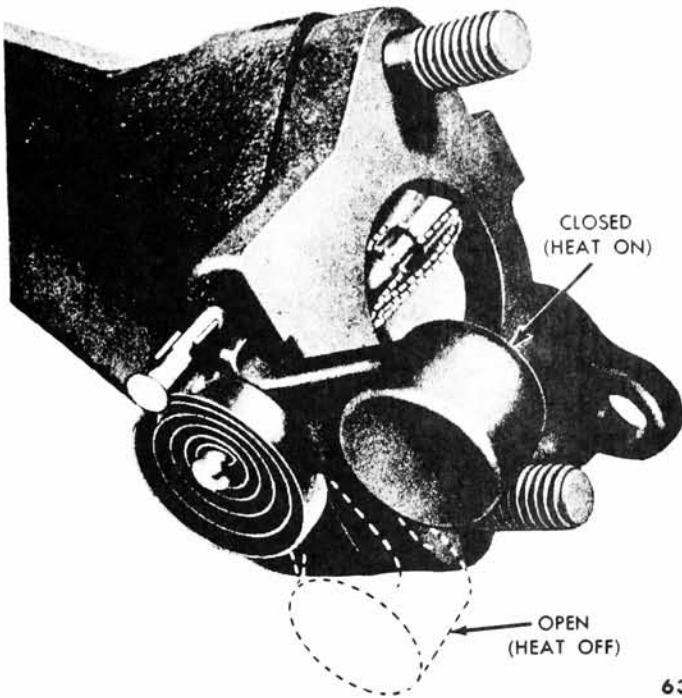

Fig. 6—Exhaust Control Valve—Single Exhaust System

them for damage. Repair or replace the manifolds as necessary.

On the intake manifold, check the fuel-air and the heat riser passages for foreign material. Inspect the surfaces for cracks or other visible defects. Repair or replace the manifolds as necessary.

CAUTION: Remove all filings and foreign matter that may have entered the manifolds as a result of repair work.

b. Exhaust Gas Control Valve.

Check the valve spring to make sure it is hooked on the stop pin. The spring stop is at the top of the valve housing when the valve is properly installed. The action of the valves is illustrated in figs. 6, 7, and 8.

Check to make sure the spring holds the valve closed when the engine is cold. Actuate the counterweight by hand to make sure it moves freely through approximately 90° of rotation without binding.

The valve is closed when the engine is at normal operating temperature and running at idle speed. How-

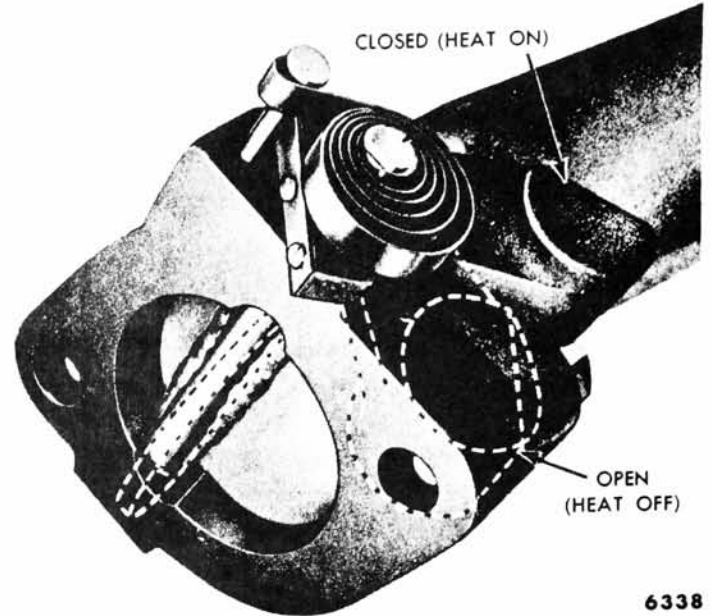

Fig. 7—Exhaust Control Valve—Dual Exhaust System

ever, a properly operating valve will open when very light finger pressure is applied to the counterweight. Rapidly accelerate the engine to make sure the valve momentarily opens. The valve is designed to open when the engine is at normal operating temperature and is operated at high r.p.m. Free stuck valves with a penetrating oil or kerosene and graphite mixture.

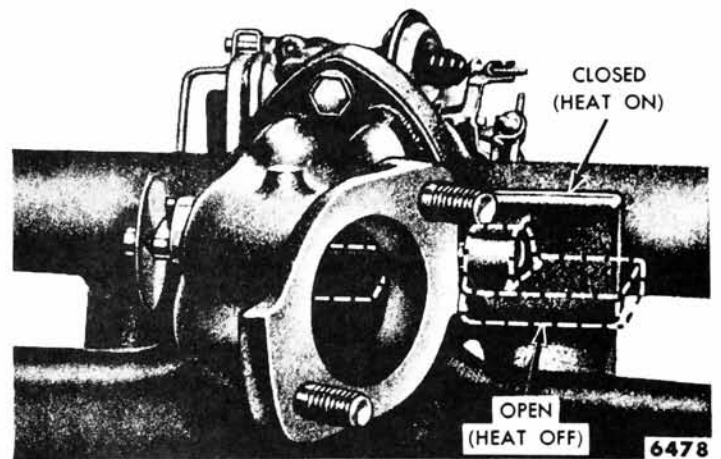

Fig. 8—Exhaust Control Valve—6-Cylinder Engine

5. ROCKER MECHANISM, CYLINDER HEAD, VALVES, VALVE LASH ADJUSTMENT, AND VALVE TIMING

This section covers the inspection and repair procedure applicable to the rocker mechanism, cylinder head, and valves. The following steps are used to adjust the valve lash. The following instructions are given.

The rocker mechanism parts are individually replaceable.

(1) **CLEANING AND INSPECTION.** Check the I. D. of the rocker arm bore and the O. D. of the rocker arm shaft at the location of the rocker arms. Inspect the rocker arms for grooved pads. Check the rocker adjust-

100% SATISFACTION GUARANTEED

BUY IT NOW!

Click Here To Order

PayPal, American Express, Discover, MasterCard, VISA

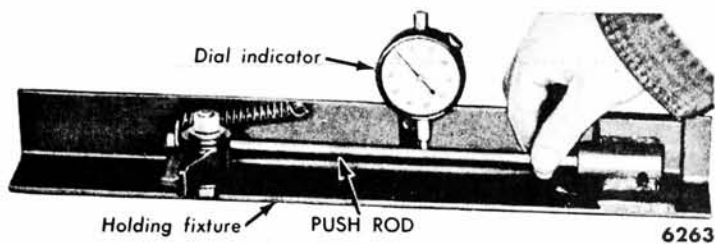

Fig. 9—Push Rod Runout Check

ing screws and lock nuts for stripped or broken threads, and the ball end of the screw for nicks and scratches or excessive wear.

Inspect the locating springs for cracks or other signs of failure.

Inspect the oil drain tube for cracks or sharp bends. Check the ball end and socket end of the push rods for nicks, grooves, roughness, or excessive wear.

A suitable check for bent push rods can be made while they are installed in the engine by rotating them (valve closed) or they can be checked between ball and cup centers with a dial indicator (fig. 9).

If the total runout of a push rod exceeds 0.020 inch, at any point, discard the rod. Do not attempt to straighten it.

(2) **REPAIRS.** If the clearance between the shaft and rocker arms is excessive, replace the shaft and/or the rocker arms. Replace all rocker arms that have severely scored or scuffed bores and/or grooved pads. Replace all scored or scuffed rocker shafts. Dress up minor nicks or scratches. Replace all damaged adjusting screws, lock nuts, and springs.

Replace the oil drain tube if it is cracked or has a sharp bend.

b. Cylinder Heads.

To protect the machined surfaces of the cylinder heads, do not remove the holding fixtures while the heads are off the engine.



Fig. 10—Cylinder Head Gasket

(1) **CLEANING AND INSPECTION.** With the valves installed to protect the valve seats, remove carbon deposits from the combustion chamber and valve heads with a scraper and a wire brush. Be careful not to scratch the gasket surface. Clean the heads with solvent to remove old gasket sealer, dirt, and grease.

Check the head for cracks. Check the gasket surface for burrs, nicks, and for flatness (fig. 10). Service specifications for flatness are 0.006 inch maximum over all, or 0.003 in any six inches. Make sure all water passages are open. Check the cylinder head core plug for evidence of leakage.

(2) **REPAIRS.** Replace the head if it cracked, or if it is damaged beyond repair.

NOTE: Do not plane or grind excessive material from the cylinder head gasket surface as the compression ratio is altered when this operation is performed.

Remove all burrs or scratches with an oil stone.

Replace any core plugs that show signs of leakage.

(3) **SPARK PLUG HOLE ADAPTERS.** If it is desired to use standard 14 millimeter spark plugs, an adapter is available which reduces the 18 millimeter hole to 14 millimeters. The adapter installation procedure is as follows:

Position a spark plug gasket on a standard 14 millimeter plug and install the plug in an adapter. Insert the spark plug and adapter assembly into the 18 millimeter hole and tighten the plug to 25-30 foot-pounds torque. This torque is sufficient to seal the adapter in place and it will not back out when the spark plug is removed. Once the adapters are installed, standard 14 millimeter spark plug gap and torque specifications apply.

c. Valve Mechanism.

Valve guides are made integral with the cylinder heads. Valves with oversized stems are available as replacements if it becomes necessary to ream the valve guides.

(1) **CLEANING AND INSPECTION.** Discard umbrella-type valve stem seals, and replace with new seals. Scrape and/or wire brush carbon from the head and stem of the valves and from the inside of the guides. Remove varnish from the valve stems. Carefully clean all carbon from the valve seat with a fine wire brush.

Check the valve for evidence of imperfect seating, heavy discoloration, burning or erosion, or warpage. Check the valve face runout (fig. 11), and also check the face for pits and grooves. Inspect the ends of the valve stem for grooves or scores.

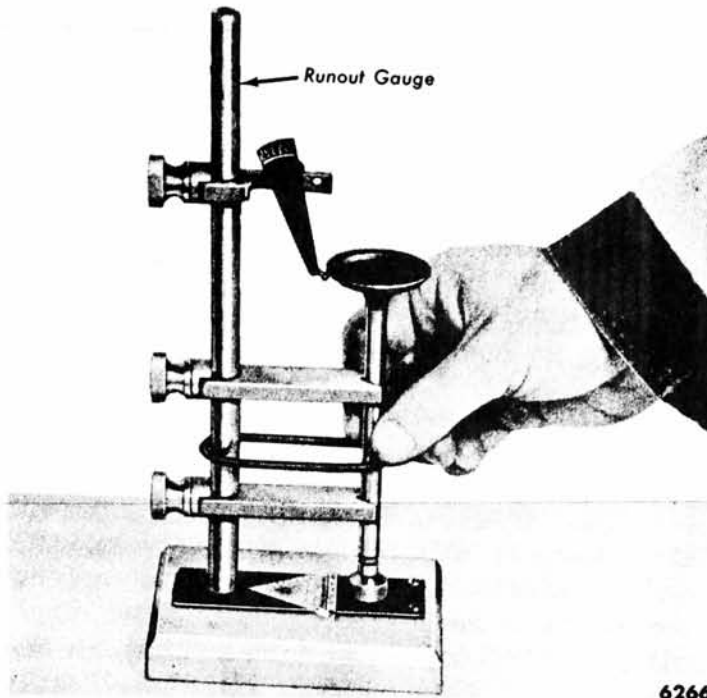

Fig. 11—Valve Face Runout Check

Inspect the valve springs for signs of failure. Check the valve spring for proper pressure (fig. 12) and squareness (fig. 13).

Check the valve spring retainers, locks, and sleeves for wear or signs of failure.

Check the valve stem clearance of each valve in its respective valve guide as shown in fig. 14. Install the tool on the valve stem until fully seated and tighten the set screw, then permit the valve to drop away from its seat until the tool contacts the upper surface of the



100% SATISFACTION GUARANTEED

BUY IT NOW!

Click Here To Order

PayPal, American Express, Discover, MasterCard, VISA

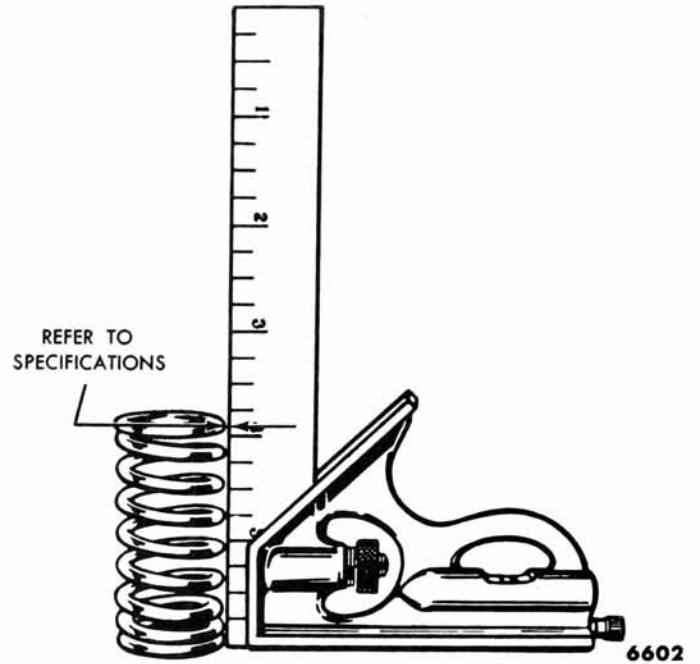

Fig. 13—Valve Spring Squareness Check

valve guide. Position a dial indicator with a flat tip against the center portion of the spherical section of the tool at approximately 90° to the valve stem. Move the tool back and forth on a plane that parallels normal rocker action and take the indicator reading without lifting the tool from the valve guide upper surface. Divide the indicator reading by 2 (division factor of the tool) to obtain the actual stem clearance.

Check the valve seat runout and the valve seat width as shown in figs. 15 and 16.

(2) **REPAIRS.** Discard any defective valves, springs, locks, retainers, or sleeves.

(a) **REFACING VALVES.** If the valve face runout is excessive, grind the valve face at a 45° angle on a

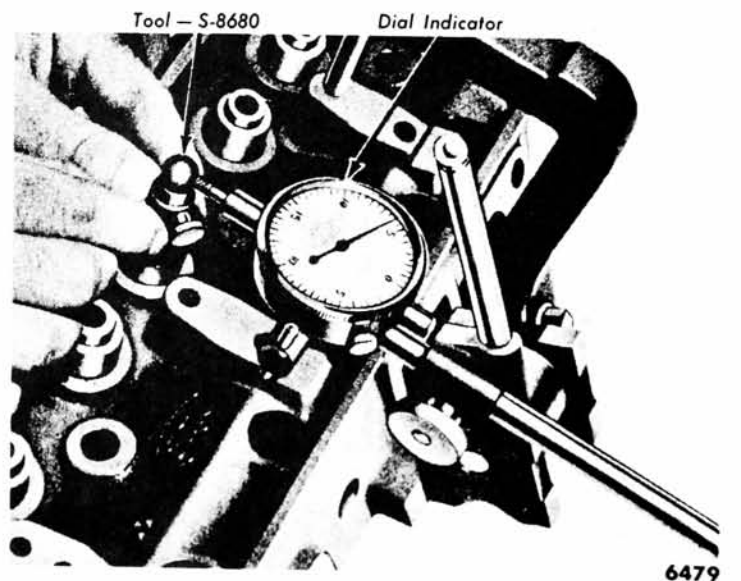

Fig. 14—Valve Stem Clearance Check—Typical

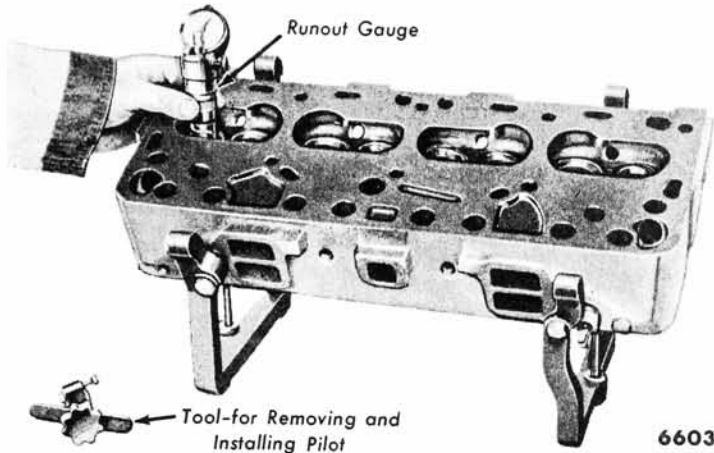

Fig. 15—Valve Seat Runout Check—Typical

6603

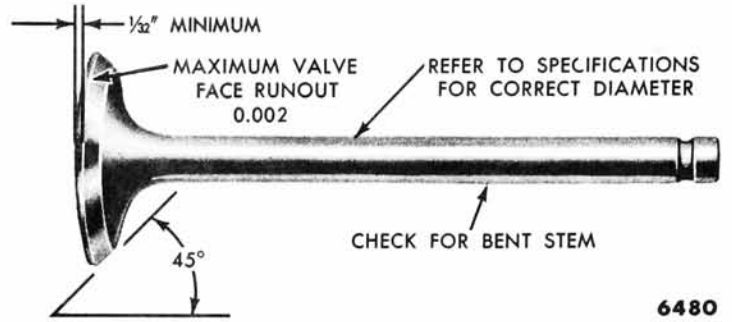

Fig. 17—Critical Valve Tolerances—Typical

6480

precision valve grinder. Follow the instructions of the equipment manufacturer. Grind off only enough stock to remove pits and grooves. If the edge of the valve head is less than $\frac{1}{32}$ inch thick after grinding, replace the valve. If the runout still exceeds specifications after grinding, check the equipment used in the grinding operation.

Grind all grooves or score marks from the end of the valve stem. Do not remove more than 0.010 inch from the stem.

The critical tolerances of the valve are illustrated in fig. 17.

(b) **REFACING VALVE SEATS.** Grind the valve seat (fig. 18) to a true 45° angle. Remove only enough stock to clean up pits or grooves. If the valve seat width exceeds specifications, remove just enough stock from the top and/or bottom edge of the seat to reduce the width to specifications. Use a 30° angle wheel to remove stock from the bottom of the seat and a 60° angle wheel to remove stock from the top (fig. 19). Keep the seat as near to the center of the valve face as possible. Place Prussian Blue on the valve seat and install the valve to check the point of contact.

After refacing valves and seats, it is good practice to lightly lap in the valves with a medium grade lapping compound to match the seats.

(c) **SELECT FITTING VALVES.** Oversize valves with a stem diameter of 0.003, 0.015, and 0.030 inch are available. Occasionally the 0.003 inch oversize valve is used in production in one or more positions.

If the valve to guide stem clearance is excessive and the diameter of the valve stem is on the lower limit (as determined by measuring the valve stem with a micrometer), select a new valve with a stem diameter on the upper limit. If in the use of standard valves the clearance cannot be reduced to a satisfactory limit, ream the valve guide (fig. 20) for the next oversize valve stem.

d. Valve Lash Adjustment.

Reference is made in the procedures for a preliminary (cold) valve lash adjustment to placing number 1 piston on top dead center (T.D.C.) at the end of the compression stroke. Number 1 piston is on T.D.C. at



Fig. 18—Refacing Valve Seat—Typical

6604

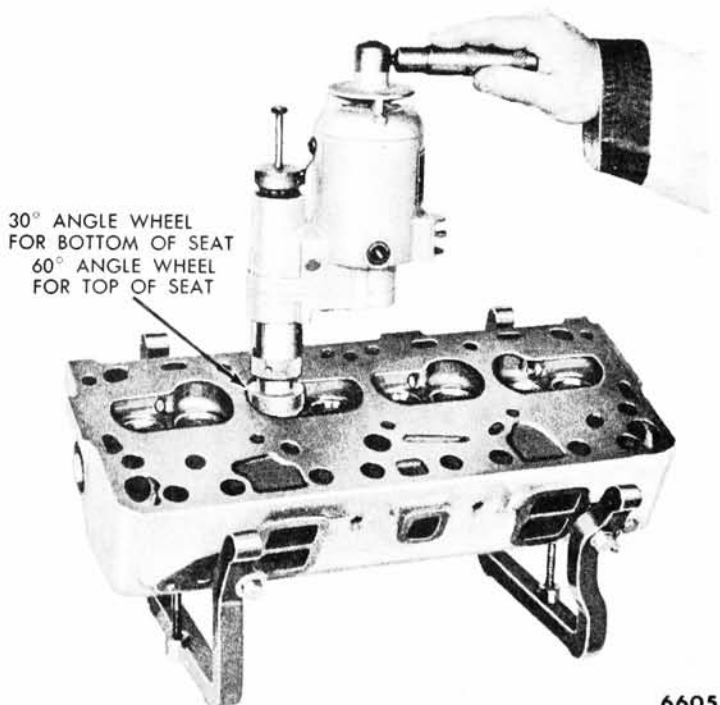

Fig. 19—Refacing Valve Seat—Typical

6605

100% SATISFACTION GUARANTEED

BUY IT NOW!

Click Here To Order

PayPal, American Express, Discover, MasterCard, VISA

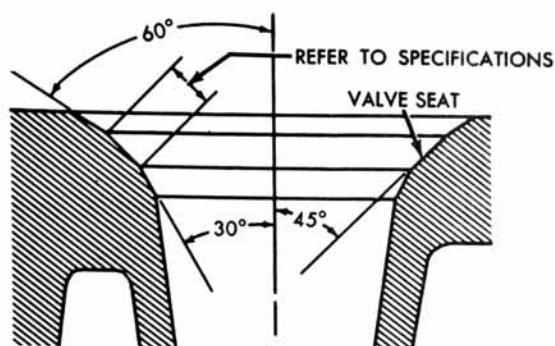

Fig. 19—Valve Seat Width

6292

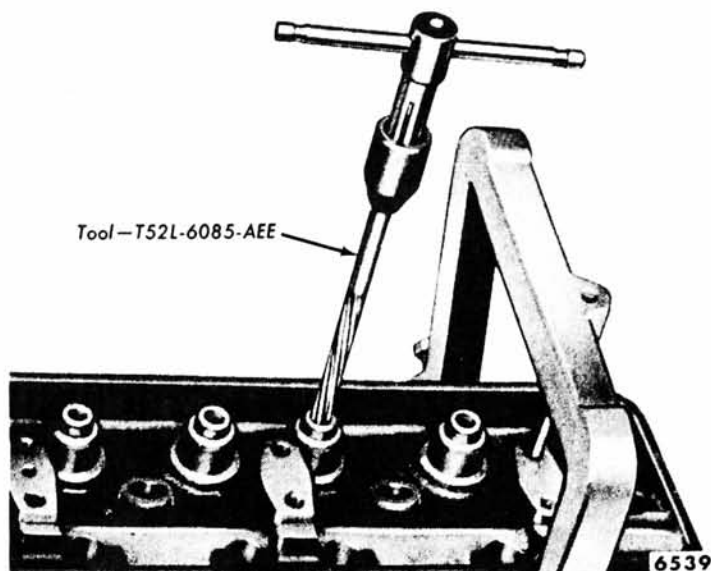

Fig. 20—Reaming Valve Guides—Typical

the end of the compression stroke when both valves are closed and the timing mark on the crankshaft damper is in line with the timing pointer.

Step-type feeler gauges (“go” and “no go”) can be used to obtain the proper clearance (fig. 21).

Valve lash is adjusted by means of the set screw and lock nut located on the push rod end of the rocker arm.

It is very important that the lash of all valves be held as close as possible to the correct specifications. If the lash is set too close, rough engine idle and poor engine performance can result. If the valve lash is excessive, valve action noise will result, and engine performance will be affected.

NOTE: *The preliminary and final valve lash adjustment specification (intake and exhaust) for all engines is 0.019*

If the cylinder head or the rocker mechanism has been removed and installed, it will be necessary to make a preliminary (cold) valve lash adjustment before starting the engine. If the adjustment is made for the purpose of engine tune-up, omit step (a) and proceed with step (b) under the procedure for the applicable engine.

(1) **6-CYLINDER ENGINE.** Remove the rocker arm cover.

(a) **PRELIMINARY ADJUSTMENT.** Make two chalk marks on the crankshaft damper. Space the marks approximately 120° apart so that with the timing mark, the damper is divided into three equal parts (120° represents 1/3 of the distance around the damper circumference).

Rotate the crankshaft until number 1 piston is near T.D.C. at the end of the compression stroke. Adjust the intake and exhaust valve lash for number 1 cylinder.

Repeat this procedure for the remaining set of valves, turning the crankshaft 1/3 turn at a time, in the direction of rotation, while adjusting the valves in the firing order sequence (1-5-3-6-2-4).

FINAL ADJUSTMENT. Run the engine for a minimum of 20 minutes at approximately 1200 r.p.m. in the firing order sequence. With the engine running, adjust the valve lash, if necessary.

(2) **8-CYLINDER ENGINES.** Remove the rocker arm covers.

(a) **PRELIMINARY ADJUSTMENT.** Make three chalk marks on the crankshaft damper. Space the marks approximately 90° apart so that with the timing mark, the damper is divided into four equal parts (90° represents 1/4 turn of the crankshaft or 1/4 of the distance around the damper circumference).

Rotate the crankshaft until number 1 piston is near T.D.C. at the end of the compression stroke and the timing mark on the damper is aligned with the timing pointer.



Fig. 21—Valve Lash Adjustment—Typical

100% SATISFACTION GUARANTEED

BUY IT NOW!

Click Here To Order

PayPal, American Express, Discover, MasterCard, VISA

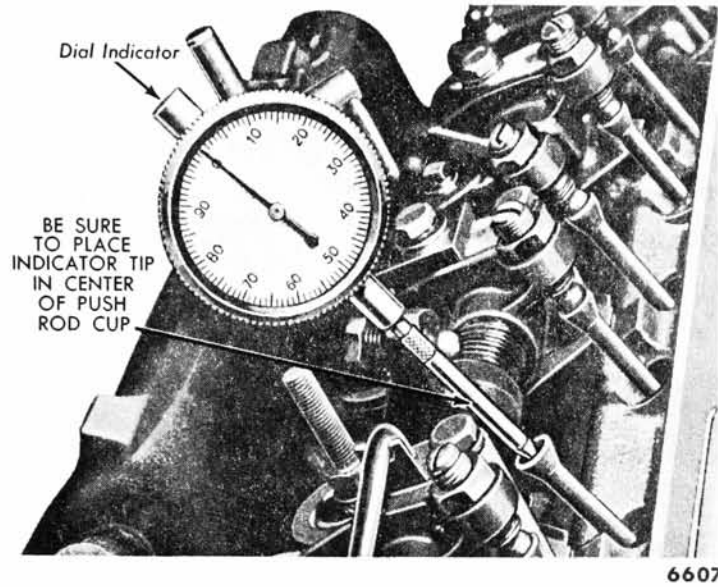

Fig. 22—Camshaft Lobe Lift Check—Typical

Adjust the lash on the following valves:

No. 1—Exhaust	No. 1—Intake
No. 4—Exhaust	No. 2—Intake
No. 5—Exhaust	No. 7—Intake

Rotate the engine 180° or ½ turn (this puts number 4 piston on T.D.C.) and adjust the following valves:

No. 6—Exhaust	No. 4—Intake
No. 8—Exhaust	No. 5—Intake

Rotate the engine 270°, or ¾ turn from 180° (this puts number 3 piston on T.D.C.) and adjust the following valves:

No. 2—Exhaust	No. 3—Intake
No. 3—Exhaust	No. 6—Intake
No. 7—Exhaust	No. 8—Intake

(b) **FINAL ADJUSTMENT.** Run the engine for a minimum of 30 minutes at approximately 1200 r.p.m. in order to stabilize engine temperatures. With the engine idling, check the valve lash. Adjust the lash, if necessary (fig. 21). Install the rocker arm covers.

e. Valve Timing.

Valve timing checks should be made when poor

engine performance is noted and all other checks, such as carburetion, ignition timing, etc., fail to correct the trouble. The following procedure can be used to determine if the valve timing is correct with the engine installed in the car.

The procedure checks the cam timing by using the opening side of number 1 intake cam lobe. At this point 1° of crankshaft rotation is equal to approximately 0.0004 inch change in cam lift.

Remove the rocker arm cover on the 6-cylinder engine. On 8-cylinder engines, remove the right rocker arm cover.

Back off the number 1 intake valve adjusting screw, then slide the rocker arm assembly to one side and secure it in this position. Make sure the push rod is in the tappet socket, then install a dial indicator in such a manner as to have the actuating point of the indicator in the push rod socket and in the same plane as the push rod movement (fig. 22). Turn the engine slowly (at either the crankshaft damper bolt or flywheel) until the tappet is on the heel of the cam lobe. Zero the dial indicator and continue turning the engine slowly until the desired lift is obtained (Table 1). Compare the degrees on the pulley with specifications.

Table 1—Valve Timing Specifications

Engine (Cubic Inch Displacement)	Intake Valve Opens—Crankshaft Degrees at Cam Lift
223	24° BTDC@ .016 Cam Lift
272, 292 and 312	12° BTDC@ .016 Cam Lift

If the valve timing is not within specifications, check for a bent timing pointer. Bring the number 1 piston to T.D.C. and see if the timing pointer is aligned with the T.D.C. mark on the crankshaft pulley or damper. If the pointer is not at fault, check the timing chain, camshaft sprocket, crankshaft sprocket, camshaft, and crankshaft pulley, in the order of accessibility.

6. TIMING CHAIN, SPROCKETS, AND CAMSHAFT

a. Timing Chain and Sprockets.

To measure timing chain deflection (fig. 23), take up the slack on the left side (as viewed from the front) in a clockwise direction. Push the block and chain against the crankshaft sprocket. With the

fingers, move the chain toward the original reference point and measure the distance between the reference point and the chain. If the difference between the two measurements (which is the slack) exceeds ½ inch, replace the timing chain and/or sprockets.

(1) **INSPECTION.** Inspect the sprockets for worn or damaged teeth. Inspect the chain for broken links.

(2) **REPAIRS.** Replace the sprockets or the timing chain as deemed necessary by inspection. However, it is recommended that all the components be replaced if any one item needs replacement.

b. Camshaft.

The camshaft should be replaced when any lobe (intake or exhaust) is worn to such an extent that the lift loss exceeds 0.005 inch. The tappet which mates with the worn lobe must also be replaced.

(1) **CAM LOBE LIFT CHECK.** This procedure is similar to the procedure for checking valve timing. Loosen the valve rocker arm adjusting screw, then slide the rocker arm assembly to one side and secure it in this position. Make sure the push rod is in the tappet socket, then install a dial indicator in such a manner as to have the actuating point of the indicator in the push rod socket and in the same plane as the push rod movement (fig. 22). Rotate the engine slowly until the tappet is on the heel of the cam lobe. Zero the dial indicator, then continue to rotate the engine slowly until the push rod is in the fully raised position. Compare the total lift recorded on the indicator with specifications. Continue to rotate the engine until the indicator reads zero. This later step is a check on the accuracy of the original indicator reading.

(2) **INSPECTION.** Thoroughly check the camshaft for damage. Examine the lobes for pitting, scoring, and signs of abnormal wear. Check the lobes with a micrometer. Suspected worn lobes should be compared with a good lobe to be sure diagnosis is correct. Measure the journal diameter for wear and out-of-roundness. Measure the I. D. of the camshaft bearings. If the clearances are excessive the cam and/or cam bearings should be replaced. Check the fuel pump eccentric for wear.

(3) **REPAIRS.** Replace all camshafts that are damaged beyond repair. Remove light scuffs, scores, or nicks with a hard Arkansas stone, then polish with crocus cloth.

The lobe wear characteristics may result in pitting in the general area of the nose portion of the lobe. This pitting is not detrimental to the operation of the cam if the initial cam lobe lift loss has not exceeded 0.005 inch. The camshaft will continue to operate satisfactorily for the normal life expectancy of the engine without noticeably affecting engine performance. Therefore, camshafts should not be replaced unless the lobe lift loss exceeds the above specification or the tappet contact face shows signs of failure.

If the front journal to bearing clearance is excessive and all bearings are worn

the distributor drive gear are

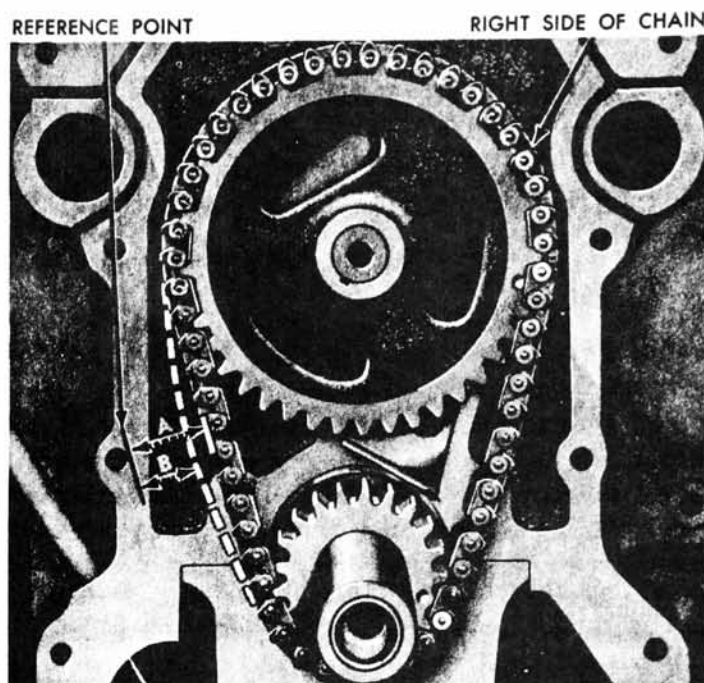

TAKE UP SLACK ON LEFT SIDE OF CHAIN. ESTABLISH A REFERENCE POINT AND MEASURE DISTANCE A. THEN, TAKE UP SLACK ON RIGHT SIDE OF CHAIN AND FORCE LEFT SIDE OF CHAIN OUT WITH THE FINGERS AND MEASURE DISTANCE B. DEFLECTION IS A. MINUS B. 6608

Fig. 23—Timing Chain Deflection—Typical

broken, worn, or scored it will be necessary to replace the camshaft.

(4) **CAMSHAFT END PLAY CHECK.** Push the camshaft toward the rear of the engine. Place a dial indicator point against a suitable surface on the front end of the camshaft assembly (fig. 24). Set the dial to zero, then pull the camshaft forward and release it. Compare the dial reading with specifications.

If the end play is excessive, check the spacer for correct installation. Replace the thrust plate and/or spacer if necessary.

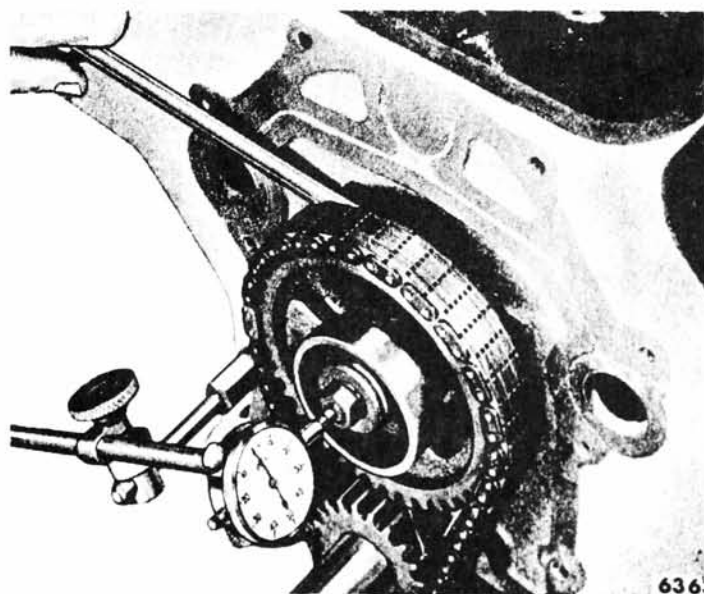

Fig. 24—Camshaft End Play Check—Typical

100% SATISFACTION GUARANTEED

BUY IT NOW!

Click Here To Order

PayPal American Express Discover Novus MasterCard VISA

7. FLYWHEEL, CRANKSHAFT, AND MAIN BEARINGS

Procedures for the inspection and repair of these components are given here. In addition, procedures for fitting main bearings, aligning the thrust bearing, and replacing the rear main bearing crankshaft oil seal are given.

a. Flywheel.

The flywheel and ring gear are a shrink fit and are replaceable as separate parts.

(1) **INSPECTION.** Check the flywheel face runout with a dial indicator (fig. 25). Be sure to hold the flywheel full forward or rearward so that crankshaft end play will not be indicated as flywheel runout. If the runout is excessive, remove the flywheel, and check the runout of the crankshaft mounting flange. It will be necessary to remove the crankshaft if the flange requires machining.

Inspect the ring gear for worn, chipped, or cracked teeth. Check the ring gear runout as indicated in fig. 26.

(2) **REPAIRS.** If the flywheel runout is excessive and the flange is not at fault, replace or machine the flywheel. Machine the friction surface of the flywheel if it is scored or worn. If it is necessary to remove more than 0.045 inch of stock from the original thickness, replace the flywheel.

If the ring gear teeth are damaged and unfit for further use, or if the runout is excessive, replace the ring gear as follows:

Heat the defective ring gear with a blow torch on the engine side of the gear, then knock it off the flywheel.

CAUTION: *Do not hit the flywheel when removing the ring gear.*

Heat the new ring gear evenly until the gear expands enough to slip onto the flywheel. Make sure the gear is seated properly against the shoulder.

CAUTION: *Do not heat any portion of the gear to a temperature higher than 500°F. If this limit is exceeded, the temper will be removed from the ring gear teeth. When the new ring gear is installed, perform a runout check on the ring gear and flywheel.*

b. Crankshaft.

Check the end play in the following manner:

Push the crankshaft toward the rear of the engine. Place a dial indicator point against the rear or front end of the crankshaft. Set the dial on zero, then push the crankshaft forward. Compare the reading on the dial indicator with specifications.

(1) **CLEANING AND INSPECTION.** Remove the crankshaft, wash it in a solvent, and blow out the oil passages with compressed air. Examine the shaft for damage.

Measure the diameter of each journal in at least four places to determine out-of-round, taper, or undersize condition (fig. 27).



6513

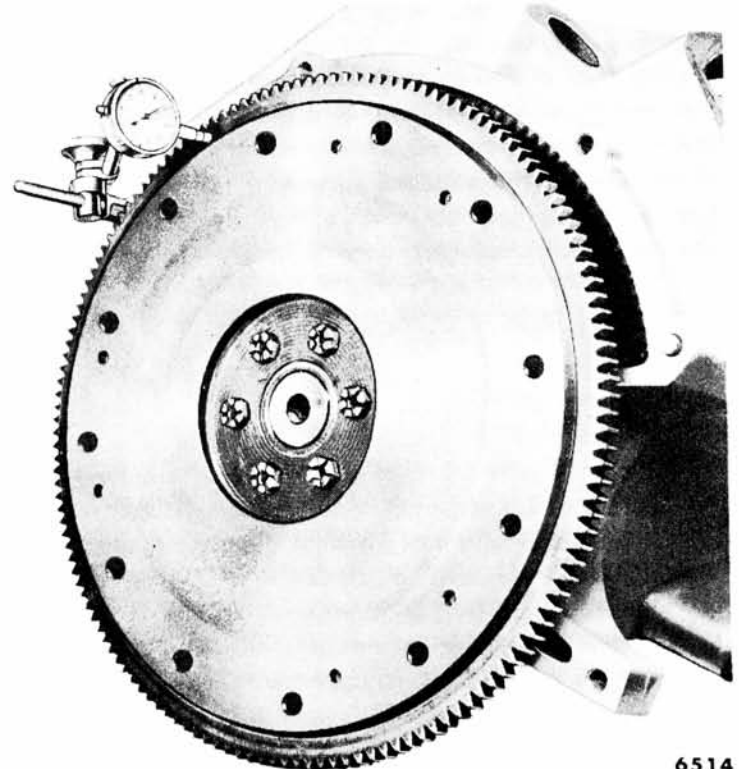

6514

Fig. 26—Ring Gear Runout Check—Typical

100% SATISFACTION GUARANTEED

BUY IT NOW!

Click Here To Order

PayPal | American Express | Discover | MasterCard | VISA

typical

(2) **REPAIRS.** If the end play is excessive, replace the thrust bearing.

Replace the crankshaft if it shows signs of failure. Dress minor nicks or scratches.

If the pins or journals are out-of-round beyond further use, the shaft should be ground for the next undersize bearing. Calculate the correct undersize bearing to be used as follows:

EXAMPLE: If the main bearing journal will “clean-up” before it is ground to $2.499 - 0.010 = 2.489$ inches diameter, finish it to that diameter, and install 0.010 inch undersize bearings.

Always reproduce the same radii in the corners of the journals that existed originally. Too small a radius will result in bearing failure.

CAUTION: Never grind journals or crankpins in excess of 0.030 inch undersize.

After grinding, chamfer the oil holes, then polish the pin or journal with number 320 grit polishing cloth and engine oil. Crocus cloth may also be used as a polishing agent.

c. Main Bearings.

The insert-type main bearings are select fit. They are available for service in standard and undersizes for use on journals that have been reground. The installation of new bearings must be closely checked to maintain the proper clearance between the journals and bearing surfaces.

(1) **INSPECTION.** Check the bearings for any damage or excessive clearance. Examples of bearing failures and their causes are illustrated in fig. 28.

(2) **FITTING MAIN BEARINGS — PLASTIGAGE METHOD.** The following procedure applies to fitting main bearings with the engine either installed on a

A VS B = VERTICAL TAPER
 C VS D = HORIZONTAL TAPER
 A VS C AND B VS D = OUT OF ROUND
 CHECK FOR OUT-OF-ROUND AT EACH END OF JOURNAL

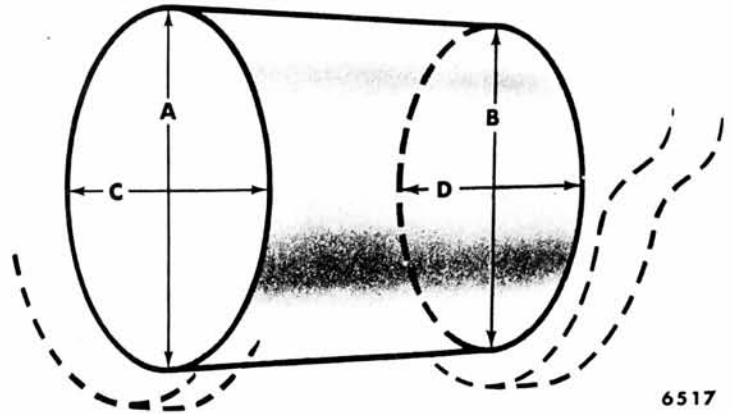

6517

Fig. 27—Checking Crankshaft Journal

workstand or in the car.

If the bearing fits are to be checked with the engine in the car, support the weight of the crankshaft with a small jack positioned to hold the crankshaft upward against the block half of the main bearings. Place the jack to bear against the crankshaft counterweight adjoining the bearing which is being checked for clearance. The shaft can also be supported by a thin rubber pad between the cap insert and the journal of two bearings that are not being checked. Tighten the bearing cap bolts just enough to hold the crankshaft up against the upper bearings.

NOTE: It is necessary to support the weight of the crankshaft when checking main bearing clearances to prevent the weight of the crankshaft from compressing the Plastigage, thereby providing an erroneous reading.

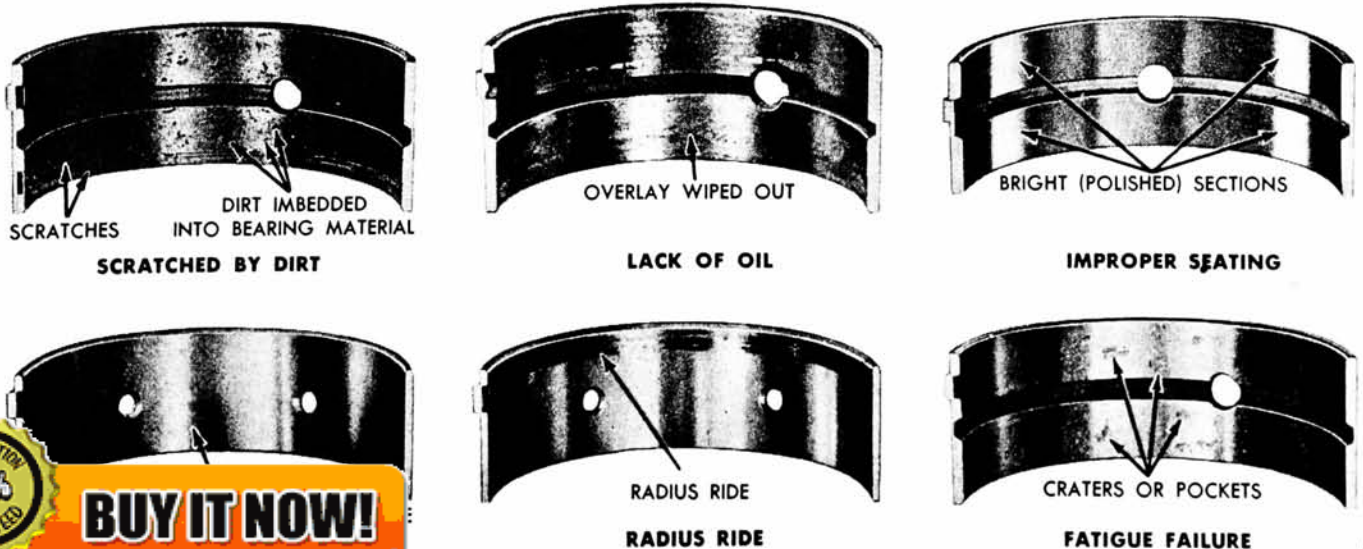

Fig. 28—Bearing Failures—Typical

6491

100% SATISFACTION GUARANTEED

BUY IT NOW!

Click Here To Order

PayPal, American Express, Discover, MasterCard, VISA

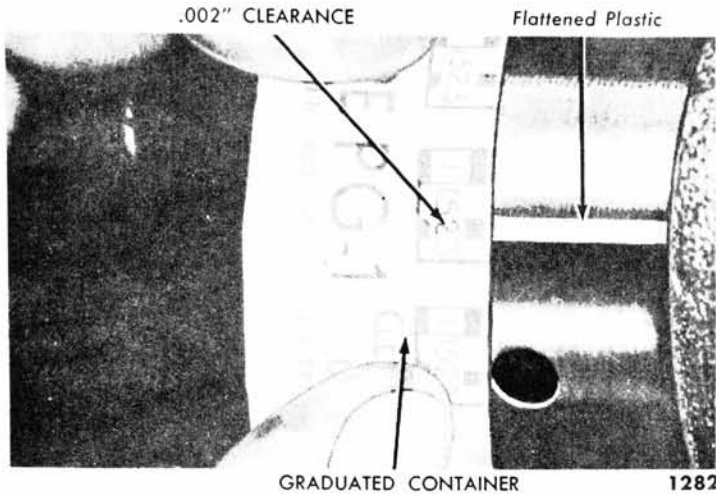

Fig. 29—Measuring Plastigage—Typical

Place a piece of Plastigage, the full width of the bearing cap, on the bearing surface (or on the crankshaft journal if the engine is inverted) about 1/4 inch off center. Install the cap and tighten the bolts to specifications.

CAUTION: Do not turn the crankshaft while the Plastigage is in place.

Remove the cap, then check the width of the Plastigage at the widest point with the Plastigage scale (fig. 29).

If the clearance is excessive, try another selective fit bearing to bring the clearance within the desired limit.

NOTE: Red marked bearings increase clearance; blue marked bearings decrease clearance.

If the various selective fit bearings do not bring the clearance within the desired limits, grind the crankshaft journal and/or journals and install undersize bearings.

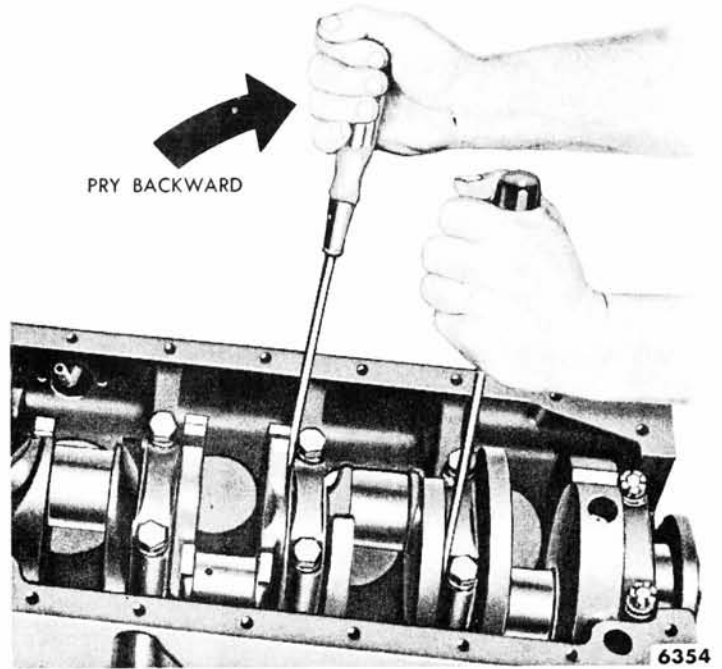

Fig. 31—Pry Cap Backward—Typical

NOTE: Normally, main bearing journals wear evenly and are not out-of-round. However, if a bearing is being fitted to an out-of-round journal, be sure to fit the bearing to the maximum diameter of the journal. If the bearing is fitted to the minimum diameter with minimum clearance, interference may result, causing an early failure. It is not recommended that bearings be fitted to a crankshaft journal which is more than 0.001 inch out-of-round.

(3) **THRUST BEARING ALIGNMENT.** Install the main bearing caps, except the thrust bearing cap, and tighten the bolts to specifications. Install the thrust



Fig. 32—Tighten Cap—Typical

100% SATISFACTION GUARANTEED

BUY IT NOW!

Click Here To Order

PayPal, American Express, Discover, MasterCard, VISA

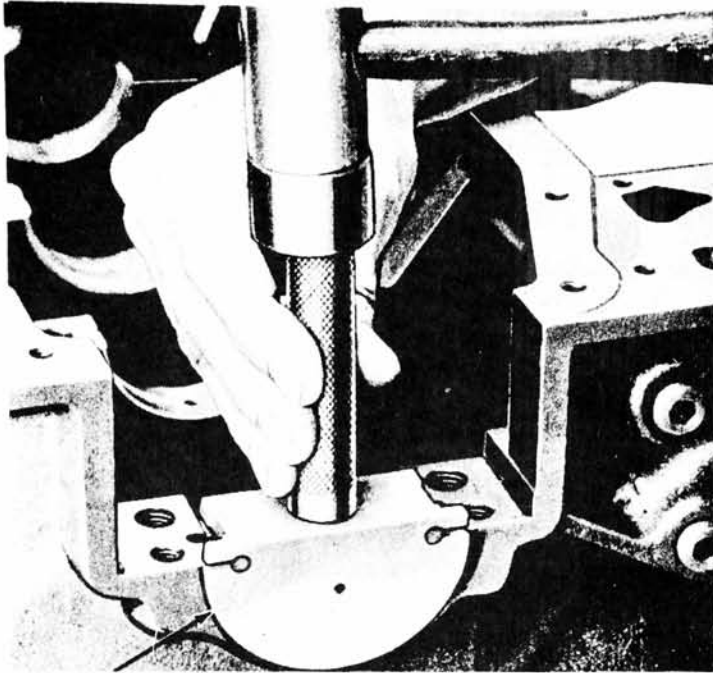

Tool—T52L-6701-AGD

6373

Fig. 33—Oil Seal to Block Installation—Typical

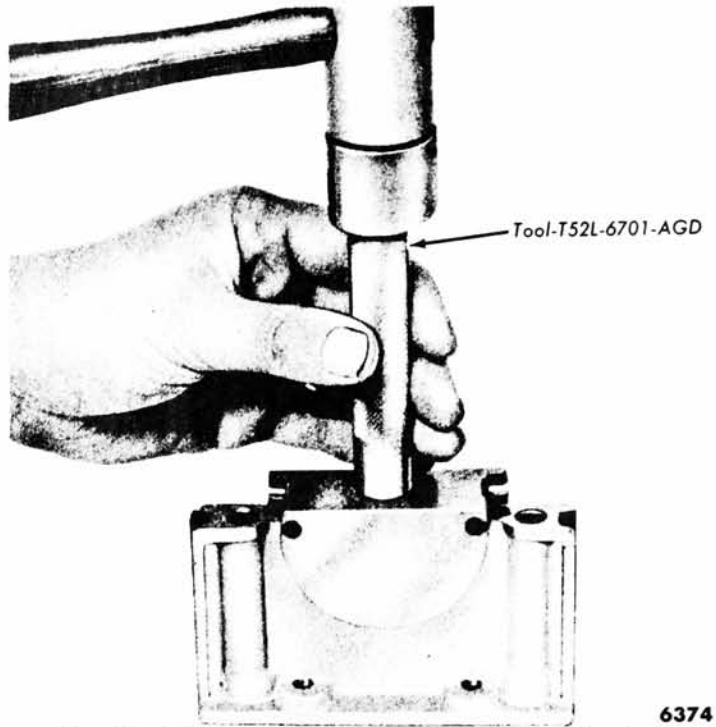

Tool-T52L-6701-AGD

6374

Fig. 34—Oil Seal to Retainer Installation—Typical

bearing cap with the bolts finger-tight, then pry the crankshaft forward against the thrust surface of the upper half of the bearing (fig. 30). While holding the crankshaft forward, pry the thrust bearing cap to the rear (fig. 31). This will align the thrust surfaces of both halves of the bearing. Retain the forward pressure on the crankshaft, and tighten the cap bolts to specifications (fig. 32). Check the crankshaft end play.

(4) **REPLACING REAR MAIN BEARING CRANKSHAFT OIL SEALS.** Remove the crankshaft journal oil seals from the cylinder block and seal retainer or bearing cap. Clean the seal grooves.

Install the new seal in the cylinder block as shown in fig. 33. After installation, cut the seals flush without any frayed edges overlapping. Install the new journal seal in the retainer or bearing cap as shown in fig. 34. After installation cut the seals flush.

Coat the rear oil seal retainer to block mating face with sealer, install the retainer and tighten the bolts to

23-28 foot-pounds torque. Dip the retainer side seals in light engine oil, then immediately install them in the grooves. It may be necessary to tap the seals into place for the last $\frac{1}{2}$ inch of travel. Do not cut the seal projecting ends.

CAUTION: Do not use sealer on the side seals. The seals are designed to expand when dipped in oil. Using sealer may retard this expansion.

To check retainer or bearing cap side seals for leaks, squirt a few drops of oil into the parting lines between the cap or retainer and the cylinder block from the outside. Blow compressed air against the seals from the inside of the block. If air bubbles appear in the oil, it indicates possible oil leakage.

NOTE: The above test should not be performed on newly installed seals until sufficient time has been allowed for the seals to expand into the seal grooves.

8. CYLINDER BLOCK, PISTONS, PISTON RINGS, AND CONNECTING RODS AND BEARINGS

During the disassembly of the cylinder block for engine overhaul, closely inspect the wear pattern on all to help diagnose the cause of wear.



BUY IT NOW!

Click Here To Order

machined surfaces. passages and clean

(1) **INSPECTION.** Make a thorough check for cracks. Minute cracks not visible to the naked eye may be detected by coating the suspected area with a mixture of 25% kerosene and 75% light motor oil. Wipe the part dry and immediately apply a coating of zinc oxide dissolved in wood alcohol. If cracks are present, the coating will become discolored at the defective area.

Make sure the threads in the head bolt holes are





Fig. 35—Cylinder Bore Measurement—Typical

clean. Dirt in the threads can cause binding and result in a false torque reading. Use a tap to true up threads and to remove deposits if necessary.

Inspect the cylinder bores for scoring, taper, out of roundness, and wear. Use a cylinder bore gauge to make the measurements (fig. 35). Follow the instructions of the tool manufacturer. Only experienced personnel should be permitted to take these measurements.

Inspect all expansion-type plugs for evidence of leakage.

(2) **REPAIRS.** To remove an expansion-type plug, drill a $\frac{1}{2}$ inch hole in the center of the plug and remove the plug as shown in fig. 36. Clean the plug recess thoroughly. Coat the flange of the new plug with sealer and install it with the flange facing out. Drive the plug in until the flange is flush or slightly below the casting surface (fig. 37).



Fig. 37—Expansion-Type Plug Installation—Typical

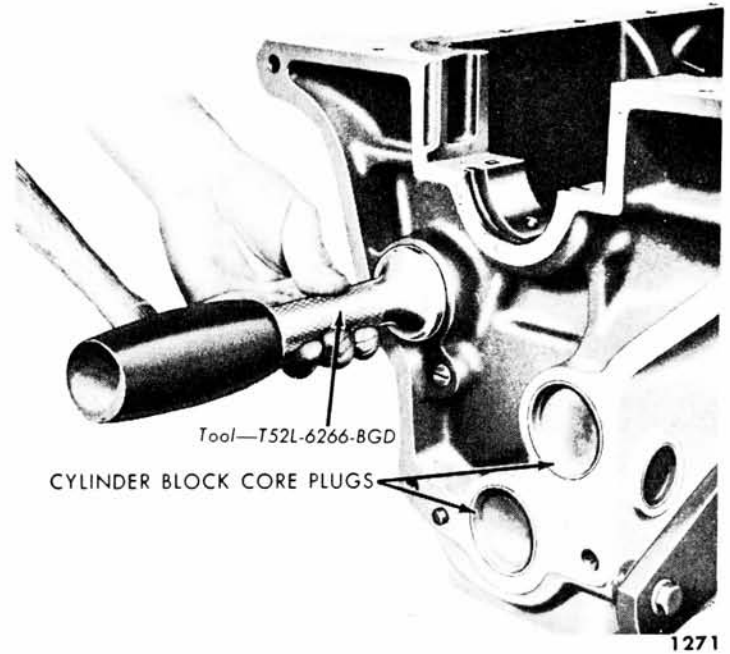

Fig. 37—Expansion-Type Plug Installation—Typical

NOTE: A 0.030 inch oversize plug is available.

Rebore cylinders that are deeply scored and when taper and/or out-of-roundness are excessive. If the cylinder bore and piston wear are not excessive, new service piston rings will give satisfactory performance.

(3) **BORING CYLINDER BLOCK.** Follow the boring equipment manufacturer's instructions. This work should be performed by experienced personnel only.

Bore the cylinder with the most wear first to determine the proper oversize. If the cylinder will not clean up when bored for the maximum oversize piston recommended, the block should be replaced. Bore the cylinder to within approximately 0.0015 inch of the required oversize diameter. This will allow enough stock for the final step of honing the bores so the correct surface finish and pattern are obtained. Use a number 220-280 grit hone for this operation.

CAUTION: Thoroughly clean the block to remove all particles after the boring and honing operations, then coat the bores with oil.

(4) **CYLINDER BORE "GLAZE" REMOVAL.** Whenever piston rings are installed in a used cylinder, remove the "glaze" on the bore to aid in ring seating.

Take all necessary precautions to catch the grit. Pass a hone or glaze removing tool through the cylinder bore a few times. Do not hone more than enough to rough-up the finish. Thoroughly clean the cylinder bore and block after glaze removal, then oil the bores.

b. Pistons, Pins, and Rings.

(1) **CLEANING AND INSPECTION.** Remove the carbon deposits from the pistons. Clean the piston ring grooves with a ring groove cleaner (fig. 38). Make sure the oil ring slots (or holes) are clean.



BUY IT NOW!

[Click Here To Order](#)



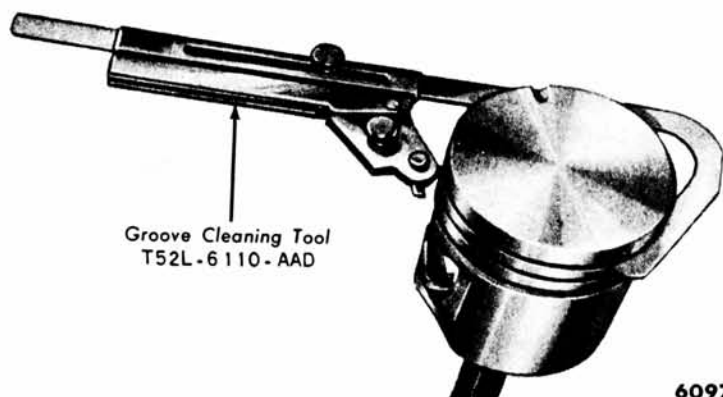

Groove Cleaning Tool
T52L-6110-AAD

6097

Fig. 38—Cleaning Ring Grooves

CAUTION: Do not use a caustic cleaning solution or a wire brush.

Inspect pistons for fractures at the ring lands, skirt, and pin bosses, and for scuffed or scored skirts. Spongy, eroded areas near the edge of the piston top are usually caused by detonation, or pre-ignition. A shiny surface on the thrust surface of the piston, offset from the centerline between the piston pin holes, can be caused by a bent connecting rod. The normal wear pattern of a piston is shown in fig. 39.

Inspect the piston pins for signs of fracture or etching. Check the pin for proper fit in the piston and rod bushing. Check for wear in the pin retainer grooves.

(2) **REPAIRS.** Replace pistons showing signs of excessive skirt clearance or ring side clearance, wavy ring lands, fractures or damage from detonation or pre-ignition.

Replace piston pins showing signs of fracture or etching. Piston pins that show wear or fit loosely in the piston or rod bushing should be replaced. Always replace all piston pin retainers.

(3) **FITTING PISTONS.** Pistons of 0.020, 0.030, 0.040 and 0.060 inch oversize are available for most engines. Check the parts catalogue for sizes available.

To fit a piston in a cylinder bore, calculate the size piston desired by taking a bore check (fig. 35) and select the proper size piston to provide the desired clearance. Check the piston being fitted by attaching a tension scale to the end of a feeler gauge ribbon ($\frac{1}{2}$ inch wide) of the proper thickness. Position the feeler on the side of the piston 90° from the piston pin hole. Invert the piston, then push the piston and feeler into the bore parallel to the crankshaft axis. Hold the piston and pull out the feeler ribbon, noting the reading on the pull scale (fig. 40).

If the scale reading is greater than the maximum allowed, pull, recheck calculations to be sure that the piston is the correct size. Check for a damaged piston or a damaged cylinder bore to

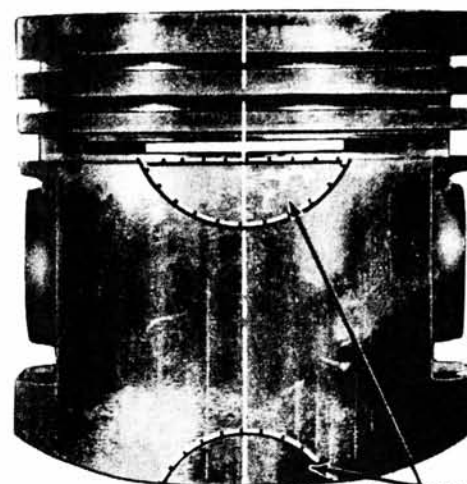

NORMAL PISTON WEAR AREAS
6609

Fig. 39—Normal Wear Pattern

able pull, recheck calculations before trying another piston. If none can be fitted, hone the cylinder to the next size piston. When a piston has been fitted, mark it for assembly in the cylinder to which it was fitted.

NOTE: All pistons are the same weight, both standard and oversize; therefore, pistons of various sizes can be intermixed without upsetting engine balance. Rebore only the cylinder or cylinders which require it.

(4) **FITTING PISTON RINGS.** Select the proper ring set for the size piston to be used. Before the rings are installed on the piston, check each ring for proper gap as follows:

Position the ring in the cylinder bore in which it is

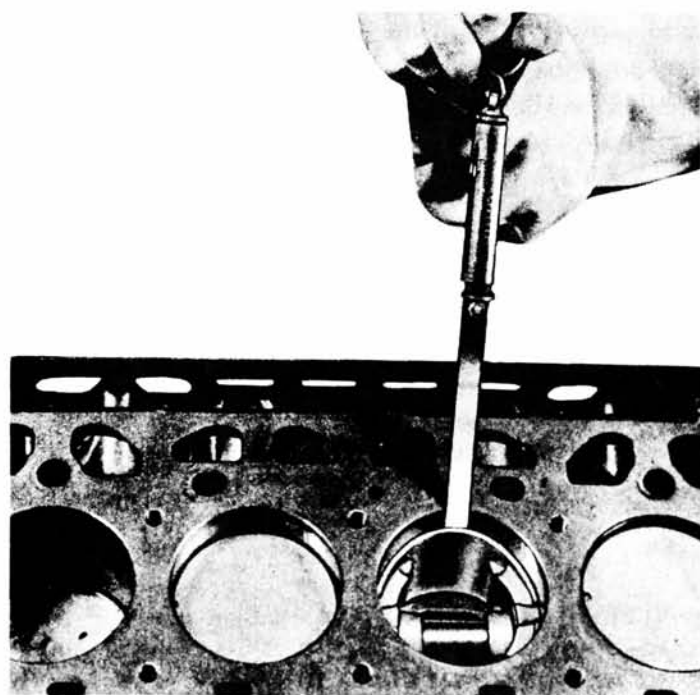

6490

Fig. 40—Fitting Piston—Typical



BUY IT NOW!

[Click Here To Order](#)



the minimum allow-

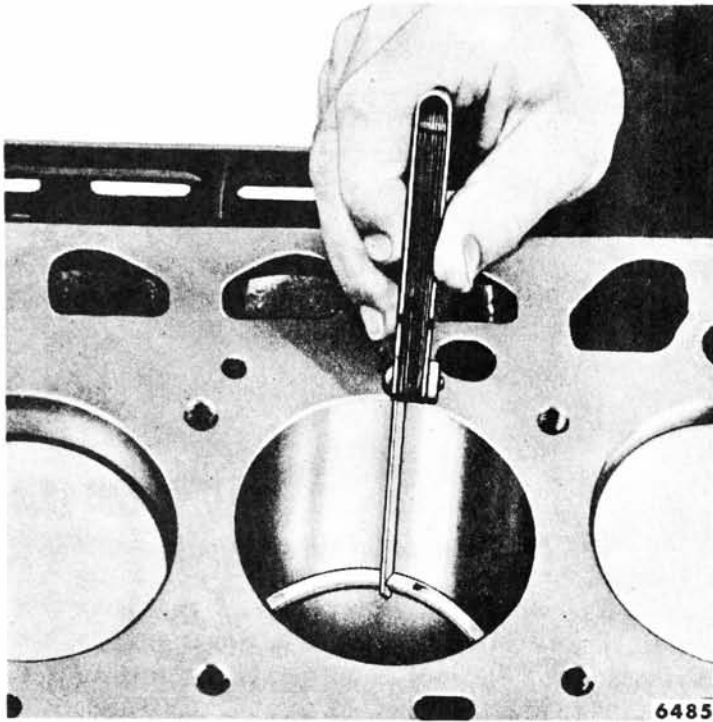

Fig. 41—Measuring Piston Ring Gap—Typical

going to be used. Push the ring down into the bore area where normal ring wear is not encountered. Use the head of a piston to position the ring in the bore so the ring is square with the cylinder wall. Use caution during this operation to avoid damage to the ring or cylinder bore. Measure the gap between the ends of the ring with a feeler gauge (fig. 41). The gap should be from 0.010-0.027 inch. If the gap is less than the lower limit, try another ring set. After the rings have been fitted in the cylinder bore, immediately install them on the piston, or identify them with the piston and cylinder in which they are to be installed.

After the rings have been installed in the ring grooves

according to the instructions on the piston ring package, check the ring side clearance with a feeler gauge. The gauge should slide freely around the entire piston ring circumference without binding.

If the rings are to be installed in a used cylinder, remove the “glaze” on the bore as previously explained.

(5) **FITTING PISTON PIN.** The piston pin fit should be a light thumb press fit at normal temperature (70° F). Standard piston pins are color coded green. Pins of 0.001 inch oversize (color coded blue) and 0.002 inch oversize (color coded yellow) are available.

If the piston pin hole must be reamed, use an expansion-type, piloted reamer. Place the reamer in a vise and revolve the piston around the reamer. Set the reamer to the size of the pin bore, then expand the reamer slightly and trial ream the pin bore. Take a light cut. Use a pilot sleeve of the nearest size to maintain alignment of the bores.

Check the reamed hole size, using the new piston pin. If the bore is small, expand the reamer slightly and make another cut. Repeat the procedure until the proper fit is obtained. Check the fitted piston pin for fit in the respective rod bushing. Ream the bushing if necessary to fit the pin.

Install the piston pin in the piston and rod. Install a retainer at each end of the pin to hold it in place. When the retainers are installed, make sure they are properly seated in the grooves provided in the piston pin bore. Always use new retainers.

c. Connecting Rod.

The connecting rods and related parts should be carefully inspected and checked for conformance to specifications. Various forms of engine wear which are caused by these parts can be readily identified as follows:

A shiny surface on the pin boss side of the piston usually indicates that a connecting rod is bent or the piston pin hole is not in proper relation to the piston skirt and ring grooves (fig. 42).

Abnormal connecting rod bearing wear can be caused by either a bent connecting rod, a crankshaft journal improperly machined, or a tapered connecting rod bore (fig. 43).

Twisted connecting rods will not create an easily identifiable wear pattern, but badly twisted rods will disturb the action of the entire piston, rings, and rod assembly that may result in excessive oil consumption.

(1) **CLEANING AND INSPECTION.** Clean all parts and passages in solvent. Never use a caustic cleaning solution. Remove the bearings (identify them if they are to be used again), then thoroughly clean the rod bore and the back of the bearings. For the different types of bearing failures and their causes, refer to Section 7. Make sure the oil squirt holes are open.



6371

100% SATISFACTION GUARANTEED

BUY IT NOW!

Click Here To Order

Fig. Boss Surface



BEARING WEAR CAUSED BY BENT ROD OR
IMPROPER GRINDING OF CRANKSHAFT JOURNAL

6372

Fig. 43—Wear Pattern on Connecting Rod Bearing

Inspect the rods for deep nicks, signs of fractures, and check the bore for out-of-roundness.

Check the connecting rod bolts and nuts for damage.

After the connecting rods are assembled to the pistons, check the rods for bend or twist on a suitable alignment fixture. Follow the instructions of the fixture manufacturer.

(2) **REPAIRS.** If the piston pin to rod bushing clearance is excessive, ream the rod bushing and piston for the next oversize pin.

If the rod is twisted or bent more than specified, it should be straightened or replaced.

Replace defective connecting rod nuts and/or bolts.

Rods with deep nicks, signs of fractures, or with the bore out-of-round more than 0.0004 inch should be replaced.

d. Fitting Connecting Rod Bearings— Plastigage Method.

Place a piece of Plastigage on the bearing surface, the full width of the bearing, about 1/4 inch off center. Install the cap and tighten the rod bolts to 45-50 foot-pounds torque.

NOTE: Do not turn the crankshaft with the Plastigage in place.

Remove the bearing cap, and use the Plastigage scale to measure the width of the flattened piece of plastic at the widest point.

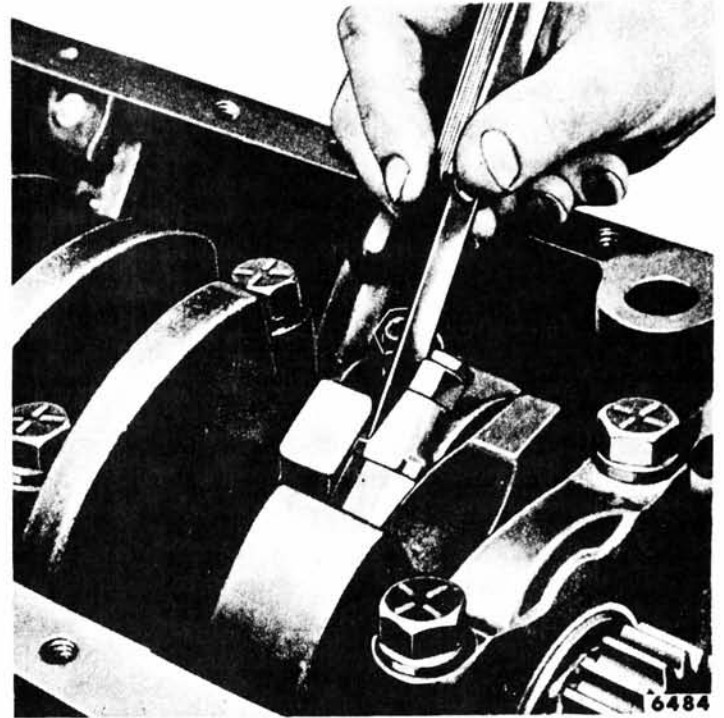

Fig. 44—Connecting Rod Side Clearance Check—Typical

NOTE: If the crankpin is out-of-round, be sure to fit the bearing to the maximum diameter of the crankpin. It is not recommended to use bearing shims of any type, or to file or lap the bearing caps in order to adjust the bearing clearance.

If the clearance is not satisfactory, try another selective fit bearing to bring to clearance within the desired limit.

NOTE: Red marked bearings increase the clearance, blue marked bearings decrease the clearance.

If the various selective fit bearings do not bring the clearance within the desired limit, it will be necessary to regrind the crankshaft journals and install undersize bearings.

Rotate the crankshaft after the bearing is installed to be sure the bearing is not too tight.

e. Connecting Rod Side Clearance.

After the connecting rods are installed, measure the side clearance with feeler stock (fig. 44).

9. OIL PAN AND OIL PUMP

Oil Pan.



BUY IT NOW!

Click Here To Order



from the inside of
material from the gasket
and dry it thoroughly.
ed from below the

baffle plate.

Check the pan for cracks, holes, damaged drain plug threads, a loose baffle, and a nicked or warped gasket surface.

Repair any damage, or replace the pan if repairs cannot be made.

Part ONE POWER PLANT

Chapter II

6-Cylinder Engine

Section	Page
1 Engine Steady Rest	31
2 Manifolds	32
3 Cylinder Head and Valves	33
4 Crankshaft Damper	36
5 Cylinder Front Cover and Crankshaft Oil Seal	36
6 Sprockets and Timing Chain, Camshaft and Bearings, and Tappets	37
7 Flywheel, Crankshaft, and Main Bearings	39
8 Connecting Rods and Bearings, Pistons, Pins, and Rings	42
9 Oil Pan, Oil Filter, and Oil Pump	44
10 Exhaust System	45

This chapter contains the removal, disassembly, assembly, and installation procedures for the component parts of the 6-cylinder engine.

The cleaning, inspection, and repair procedures for the component parts and engine overhaul instructions are covered in Chapter I, "General Engine Overhaul,

Inspection, and Repair." In addition, engine trouble shooting and tune-up are covered in Chapter I.

The 6-cylinder, EBP engine (fig. 1) has a bore of 3.62 inches, a stroke of 3.6 inches, and an 8.0:1 compression ratio.

This engine is available in all car models (except the Thunderbird).

1. ENGINE STEADY REST

The engine steady rest (fig. 2) does not support any engine weight and, as its name implies, it functions as a stabilizer only.

a. Removal.

Remove the two clamp bolts at the front of the steady

rest. Remove the spacer bolt that retains the insulators in the bracket. Remove the insulators. Remove the two bolts from the left side and the one bolt from the right side of the engine block, then remove the bracket assembly.

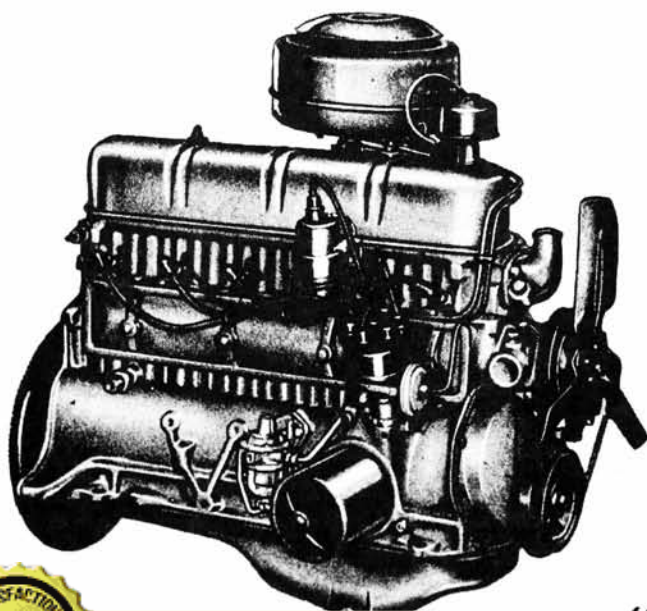

6615
Right Front View

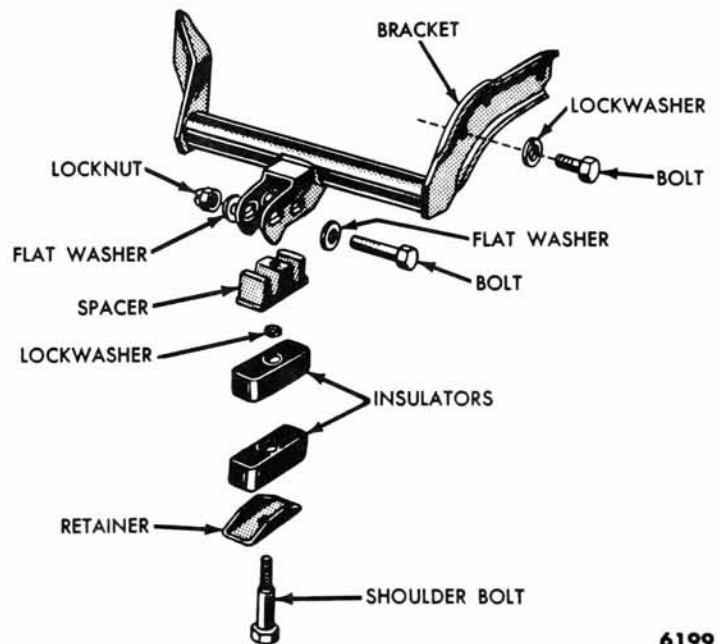

6199
Fig. 2—Steady Rest Disassembled

100% SATISFACTION GUARANTEED

BUY IT NOW!

Click Here To Order

PayPal American Express Discover MasterCard VISA

b. Installation.

Before installing the steady rest, inspect all the components for defects. Replace defective parts. Install the bracket on the cylinder block. Tighten the bolts to 23-28 foot-pounds torque. Install, but do not tighten, the insulators, spacer bolts, and clamp bolts. If necessary, cen-

ter the spacer bolt in the frame bracket by shifting the engine front mounts in their frame brackets. Then, tighten the spacer bolt to 20-25 foot-pounds torque. Make sure engine weight is not being transferred to the steady rest insulators, then tighten the clamp bolts to 25-30 foot-pounds torque.

2. MANIFOLDS

A chamber (heat riser) is cast into the intake manifold center section where the carburetor and exhaust manifold are attached. A thermostatically controlled valve, located in the exhaust manifold, directs exhaust gases into this area to provide the necessary heat required by the intake manifold to assist in vaporizing the incoming fuel mixture.

a. Removal.

Disconnect the throttle linkage at the manifold bell crank. Remove the air cleaner and the carburetor.

Disconnect the muffler inlet pipe. Remove the bolts fastening the manifold to the head, and lift the manifold assembly from the head. Remove the gaskets and sleeves. Remove the nuts and bolt joining the manifolds, then separate the manifolds. A disassembled view of the manifolds is shown in fig. 3.

b. Exhaust Gas Control Valve

The exhaust control valve is located in the outlet of

the exhaust manifold. Normally, it does not require replacement unless it becomes inoperative due to excessive corrosion or damage.

Before removing the valve assembly, note the position of the counterweight in relation to the valve plate. Remove the cotter pin, shield, washer, stop spring and thermostat spring from the front end of the shaft. Using an acetylene torch in the inside of the manifold, cut the shaft on both sides of the valve plate. Use caution to avoid damage to the shaft bearing bores. Remove the valve and shaft pieces. Clean the bearing bores of corrosion and repair any damage that may have occurred. Replace the bearings if necessary. Lubricate the new shaft and bearing bores with a penetrating oil or kerosene and graphite mixture. Insert the shaft through the bearings and valve plate. Rotate the shaft in the valve plate until the counterweight is in the normal "up" (heat on) position (fig. 4). Weld the valve to the shaft in the original manner. The shaft and valve are stainless steel to minimize corrosion and/or damage by excessive heat.

Install the thermostat spring in the shaft slot. Tighten the spring $\frac{3}{4}$ turn and hook the open end of the spring over the stop pin. The thermostat spring should hold the valve in the closed or "heat on" position (i.e. in the proper position to direct the flow of gases into the heat riser). Install the stop spring, shield, washer and cotter pin. Lubricate the shaft bearings while operating the valve manually to replace original lubricant lost through performing the welding operation.

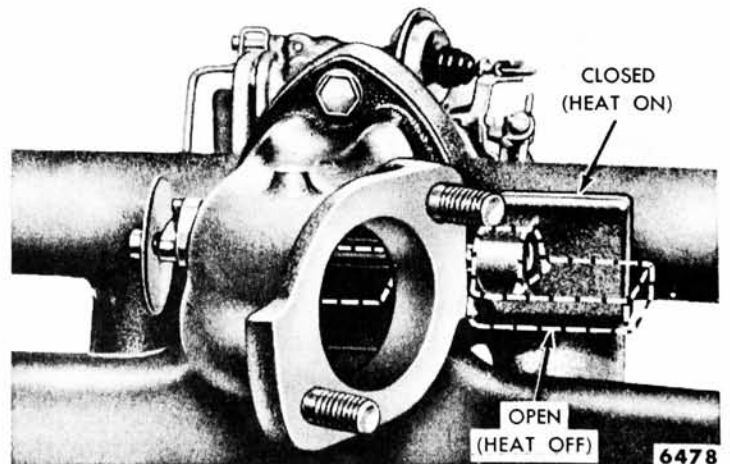

Fig. 4—Exhaust Control Valve

c. Installation.

Place the intake manifold over the studs on the exhaust manifold. Install the lock washers, nuts and bolt, then tighten them finger tight. Clean the mating surface of the cylinder heads. Inspect and repair any damage at the mating surfaces. Install new gaskets using new sleeves, if necessary, in the port of the cylinder head. Coat the mating surfaces lightly with graphite grease, then place the manifold assembly in position against the head.

NOTE: *Make sure the port openings in the manifold assembly are aligned with the port openings in the*

cylinder head and that none of the steel gaskets have become dislodged.

Tighten the bolts to 23-28 foot-pounds torque, tightening from the center to the ends. Tighten the bolt and nuts joining the intake and exhaust manifolds to 23-28 foot-pounds torque. Install a new exhaust outlet flange gasket, and position the muffler inlet pipe over the studs. Install the nuts and lockwashers, then tighten the nuts to 23-28 foot-pounds torque.

Connect the throttle linkage. Install the carburetor and connect the carburetor linkage. Install the air cleaner.

3. CYLINDER HEAD AND VALVES

The cylinder head carries the valves and valve rocker arm mechanism, the manifold assembly, ignition coil, and the water outlet.

Valve guides are an integral part of the cylinder head. Both the intake and exhaust valve assemblies are the rotating-type which incorporate umbrella-type valve stem seals.

a. Cylinder Head Removal.

Drain the cooling system. Remove the radiator upper hose and heater hose. Remove the air cleaner, then tape the carburetor air horn closed. Disconnect the battery cable at the cylinder head. Disconnect the windshield wiper vacuum line, accelerator rod, choke cable, temperature sending unit wire, and oil pressure sending unit wire.

Disconnect the coil from the head and move it to one side. Remove the spark plug wires and remove the spark plugs.

Disconnect the fuel line at the carburetor and the fuel pump. Disconnect the distributor vacuum line at the carburetor and the distributor. Disconnect the manifold vacuum line at the manifold and at the booster pump, then remove the three lines as an assembly.

Remove the rocker arm cover. Remove the cap screw and clip from the number 6 rocker arm support bracket. Pull the oil feed line out of the bracket, then pull it out of the block with pliers (fig. 5). Be careful not to damage the line.

Loosen all rocker arm adjusting screws to remove the valve spring load from the rocker arms, then remove the rocker arm shaft assembly.

Remove the valve push rods in sequence. Identify them so they can be installed in their original positions (fig. 6).

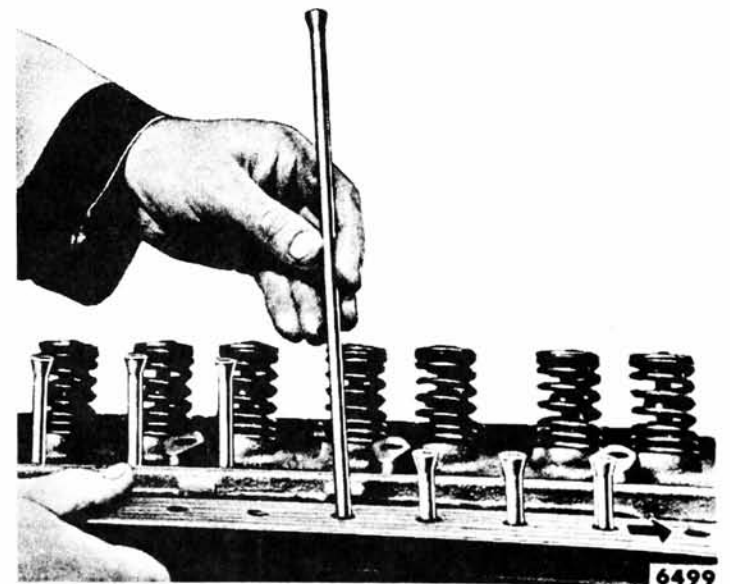

Fig. 6—Valve Push Rod Removal

100% SATISFACTION GUARANTEED

BUY IT NOW!

[Click Here To Order](#)

PayPal American Express Discover MasterCard VISA

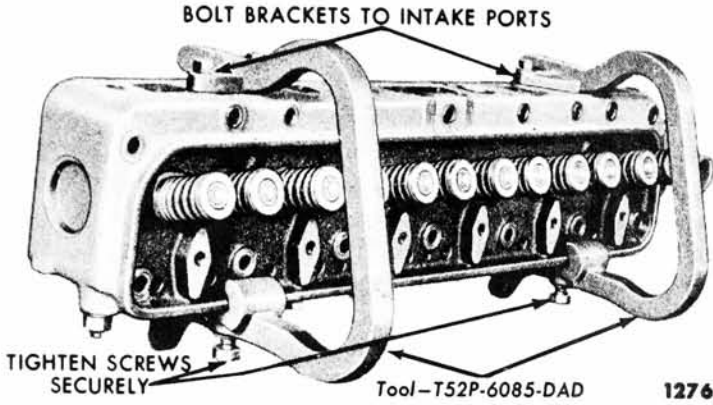

Fig. 7—Cylinder Head Holding Fixture

Remove the manifold to head bolts, and pull the manifold assembly away from the head. Brace the assembly so the inlet pipe will not be damaged.

Install the cylinder head holding fixtures for convenience in lifting the head and to protect the gasket surfaces (fig. 7).

Remove all cylinder head bolts. Install the cylinder head guide studs (fig. 8). Lift the cylinder head assembly off the engine.

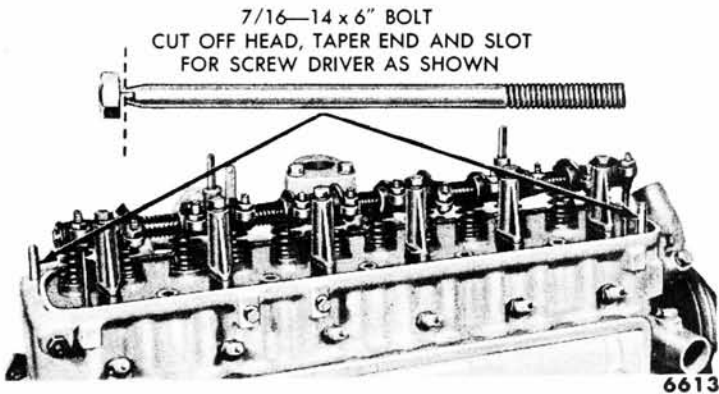

Fig. 8—Cylinder Head Guide Studs

CAUTION: Do not pry between the head and block as the gasket surfaces may become damaged.

b. Rocker Shaft Disassembly.

Pull the oil drain line and clip out of the number 1

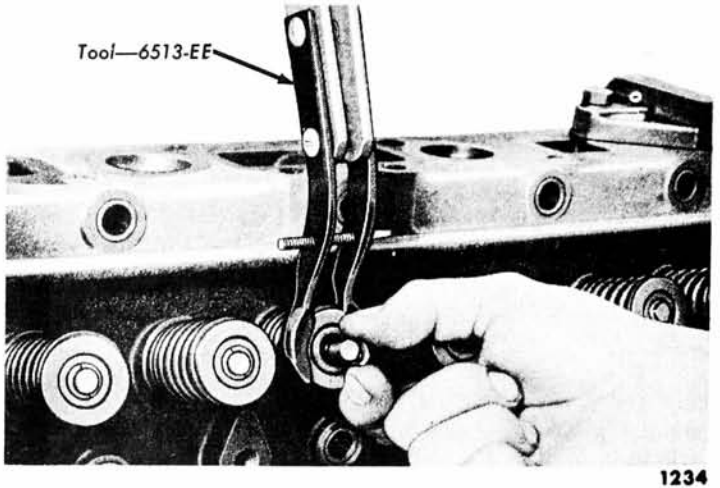

Fig. 9—Valve Stem Lock Removal or Installation

support bracket. Remove the cotter pins at each end of the rocker arm shaft, and remove the flat washers and spring washers. Remove the plugs at each end of the shaft.

NOTE: The plugs are an interference fit. To remove the plugs, drill or pierce the plug on one end, then use a steel rod to knock out the plug on the opposite end. Working from the open end, knock out the remaining plug.

Slide the rocker arms, springs, and brackets off the shaft. Be sure to identify the parts.

c. Cylinder Head Disassembly.

Clean the carbon out of the combustion chambers before removing the valves. Compress the valve springs (fig. 9), then remove the valve retainer locks and release the spring. Remove the sleeve, spring retainer, spring, stem seal, and valve.

Discard the valve stem seals. Identify all valve parts.

d. Rocker Shaft Assembly.

Oil all moving parts with engine oil. Using a blunt tool or large diameter pin punch, install a plug, cup side out, in each end of the rocker shaft. Install a flat

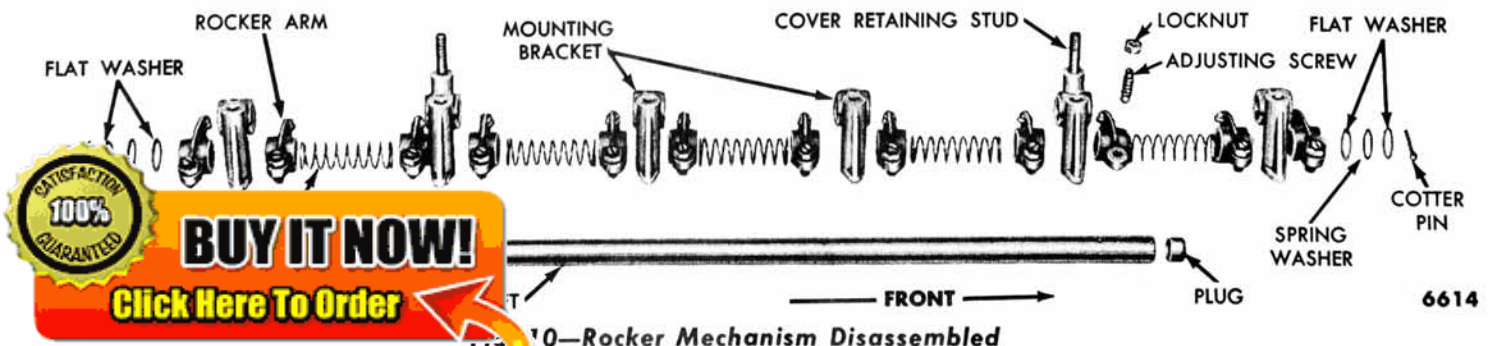

100% SATISFACTION GUARANTEED

BUY IT NOW!

Click Here To Order

PayPal, American Express, Discover, MasterCard, VISA

Fig. 10—Rocker Mechanism Disassembled

washer, spring washer, another flat washer, and a cotter pin on one end of the shaft. Install the rocker arms, support brackets, and springs in the order shown in fig. 10. Complete the assembly by installing the remaining flat washers with the spring washer between them, and install the cotter key.

e. Cylinder Head Assembly.

Install each valve in the port from which it was removed or to which it was fitted. Install a new stem seal on the valve. Install the valve spring with the closed coil against the head surface, then install the valve spring retainer, and sleeve. Compress the spring, and install the retainer locks (fig. 9).

Measure the valve spring assembled height from the machined surface of the cylinder head spring pad to the spring retainer contact surface as shown in fig. 11. If the assembled height is $1\frac{13}{16}$ inches or greater, install the necessary 0.030 inch thick spacer and/or spacers between the cylinder head valve spring pad and the valve spring to bring the assembled height to the recommended dimension of $1\frac{25}{32}$ - $1\frac{13}{16}$ inches.

CAUTION: Do not install spacers unless necessary. Use of spacers in excess of recommendations will result in overstressing the valve springs which will lead to excessive load loss and spring breakage.

f. Cylinder Head Installation.

Clean carbon deposits and gasket sealer residue from the head and block gasket surfaces. Inspect the head for any damage and repair as necessary. Apply a coating of cylinder head gasket sealer to both sides of a new gasket. Use the brush furnished to spread the sealer evenly over the entire gasket surface. Position the gasket over the guide studs on the cylinder block. Lift the cylinder head over the guides and slide the head down carefully. Before installing the cylinder head bolts, coat the threads of each bolt with a small amount of water resistant sealer. Install two bolts at opposite ends of the head to hold the head and gasket in position. Remove the guides, then install the remaining bolts. Remove the cylinder head holding fixtures. The cylinder head bolt tightening procedure is performed in three progressive steps. First, tighten the bolts to 55 foot-pounds torque (cold) in the sequence shown in fig. 12, then tighten them to 65 foot-pounds torque (cold) in the same sequence. Install the push rods in their proper sequence. Position the lower end of the rods in the tappet sockets. Install the push rod assembly on the head, and retaining screw. Position the oil line enters the oil feed line on the

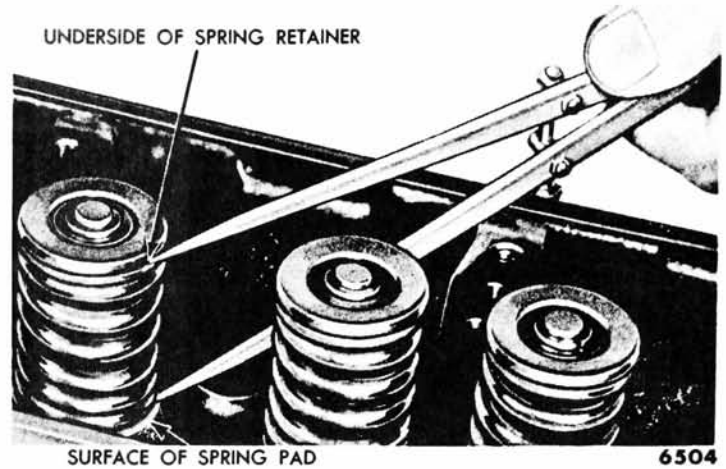

Fig. 11—Checking Valve Spring Assembled Height—Typical

number 6 bracket. Make sure the lower end of the oil line "O" ring seal is in the oil supply counterbore, then install the bolt. Tighten all the retaining bolts to 45-55 foot-pounds torque. Perform a preliminary (cold) valve lash adjustment.

Install the manifold assembly, the ignition coil, and spark plugs. Connect the spark plug wires and the temperature sending unit wire. Connect the radiator upper hose and the heater hoses. Install the accelerator pedal rod. Position the two vacuum lines and the fuel line on the engine, then connect the lines. Connect the windshield wiper hose. Connect the battery cable to the head. Fill the cooling system. Remove the tape from the carburetor air horn, then connect the choke wire. Start the engine and run it for a minimum of 30 minutes at approximately 1200 r.p.m. With the engine warmed up, tighten the cylinder head bolts, in proper sequence, to 75 foot-pounds torque (hot), then check the valve lash with the engine idling and adjust it if necessary.

NOTE: After the cylinder head bolts have been tightened to specifications, the bolts should not be disturbed.

Coat one side of the rocker arm cover gasket with oil resistant sealer, and lay the cemented side of the gasket in place in the cover. Install the rocker arm cover, making sure that the gasket seats evenly all around the head. Install the rubber seals on the studs making sure they are centered in the cover openings. Tighten the retaining nuts to 2.0-2.5 foot-pounds torque.

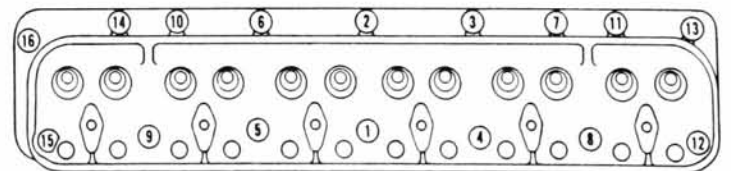

Fig. 12—Cylinder Head Bolt Tightening Sequence



BUY IT NOW!

Click Here To Order



4. CRANKSHAFT DAMPER

A single sheave crankshaft damper and pulley assembly is standard. The assembly is keyed to the crankshaft and retained with a cap screw and washer. Two threaded holes are provided in the damper to facilitate removal.

On cars equipped with power steering, an additional single sheave pulley is bolted to the crankshaft damper to drive the power steering pump.

a. Removal.

Remove the radiator. Remove the drive belts.

On cars equipped with power steering, remove the two bolts and lockwashers that fasten the power steering pump pulley to the crankshaft damper and remove the pulley.

Remove the cap screw and washer from the end of

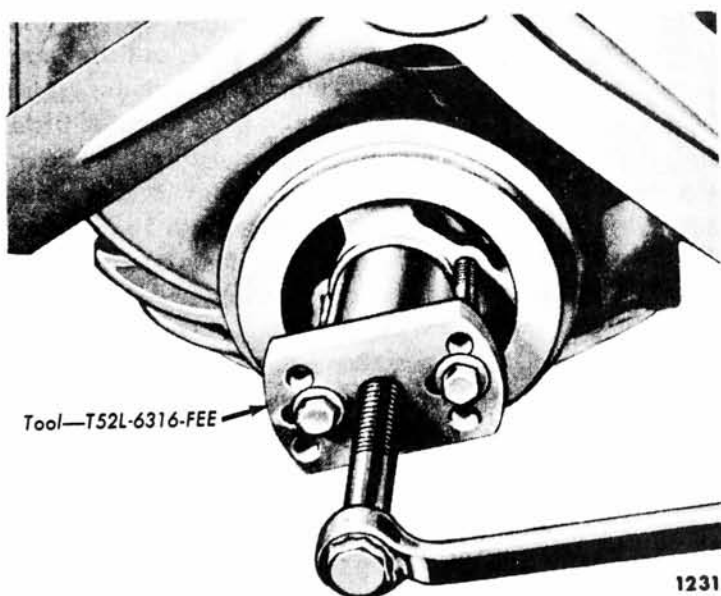

Fig. 13—Damper Removal

the crankshaft. Install the tool shown in fig. 13 and remove the damper.

b. Installation.

Lubricate the crankshaft with an oil and white lead mixture and lubricate the oil seal rubbing surface with grease. Align the damper keyway with the key on the crankshaft, and start the damper on the shaft. Press the damper on the shaft (fig. 14). Install the lockwasher and capscrew, then tighten the bolt to 85-95 foot-pounds torque. Install and adjust the generator belt.

On cars equipped with power steering, install the power steering pump pulley on the crankshaft damper. Tighten the retaining bolts to 23-28 foot-pounds torque. Install and adjust the power steering pump belt.

Install the radiator.

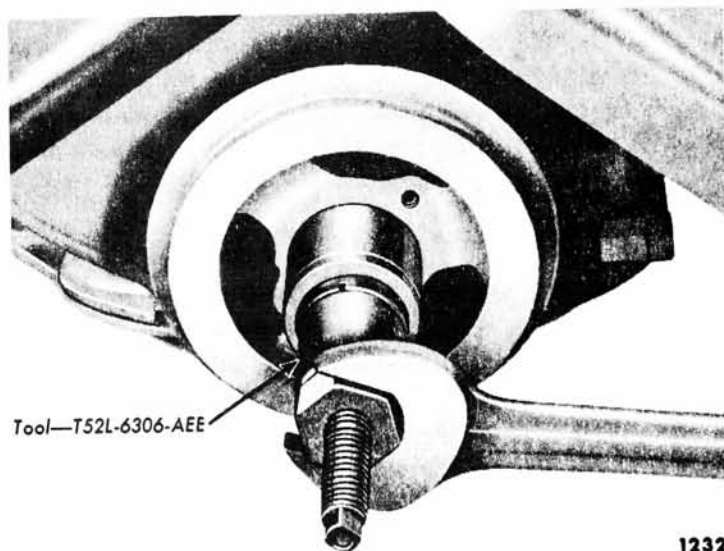

Fig. 14—Damper Installation

5. CYLINDER FRONT COVER AND CRANKSHAFT OIL SEAL

The cylinder front cover is fastened to the cylinder block by ten pan head screws and to the oil pan by two bolts. Two dowels are used to locate the cover and the timing pointer is welded to

a. Cylinder Front Cover Removal.

Remove the radiator, the crankshaft damper, and the oil pan. Remove the cover retaining screws, the cover, and the gasket.

b. Oil Seal Replacement.

Drive out the old seal with a pin punch, then clean out the recess in the cover. Coat a new seal with grease,

100% SATISFACTION GUARANTEED

BUY IT NOW!

Click Here To Order

Use the front oil seal when the front oil seal cover is removed.

then install the seal (fig. 15). Drive the seal in until it is fully seated in the recess. Check the seal after installation to be sure the spring is properly positioned in the seal.

c. Cylinder Front Cover Installation.

Clean the cylinder front cover and the gasket surface of the cylinder block. Coat the gasket surface of the block and the cover with sealer, then position a new gasket on the block. Place the cover on the block and install the retaining screws. Tighten the screws to 6-9 foot-pounds torque. Install the oil pan. Install the crankshaft damper and belt.

On cars equipped with power steering, install the power steering pump pulley and belt.

Install the radiator.

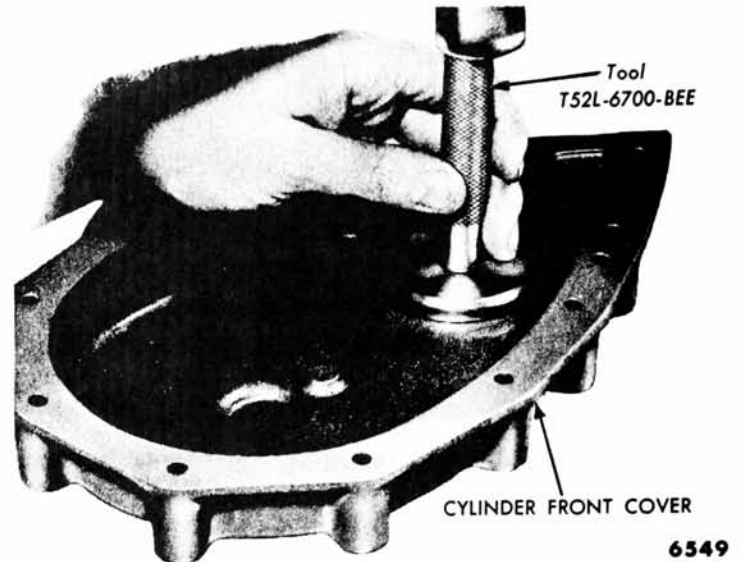

Fig. 15—Oil Seal Installation—Typical

6. SPROCKETS AND TIMING CHAIN, CAMSHAFT AND BEARINGS, AND TAPPETS

The camshaft is supported by four steel-backed babbitt insert-type bearings pressed into the block. It is driven by a sprocket and timing chain in mesh with a sprocket on the crankshaft. Camshaft thrust is controlled by a spacer and a thrust plate located between the camshaft sprocket and the shoulder on the camshaft. The plate is bolted to the front of the block. An eccentric, made integral with the camshaft, operates the fuel pump.

The removal and installation procedures given below are applicable when the engine is stalled in the car. If the engine is removed, eliminate any steps not applicable.

a. Sprockets and Timing Chain.

The camshaft sprocket is a slip fit on, and is keyed to, the end of the camshaft.

(1) **REMOVAL.** Remove the radiator and the cylinder front cover. Crank the engine until the timing marks on the sprockets and chain are positioned as shown in fig. 16.

Remove the camshaft sprocket retaining bolt and washer. Slide both sprockets and the timing chain forward and remove them as an assembly.

(2) **INSTALLATION.** Place the keys in position in the slots on the crankshaft and camshaft. Position the sprockets and timing chain on the camshaft and crankshaft. Be sure the timing marks on the sprockets and chain are positioned as shown in fig. 16. There are 12 timing marks on the

bolt. Tighten the bolt to 45-50 foot-pounds torque.

Install the cylinder front cover, crankshaft damper, belt, and radiator.

On cars equipped with power steering, install the power steering pump pulley and belt.

b. Camshaft.

The camshaft and related parts are shown in fig. 17.

(1) **REMOVAL.** Remove the radiator support bar, radiator, and the radiator grille assembly, cylinder front cover, and oil pan.

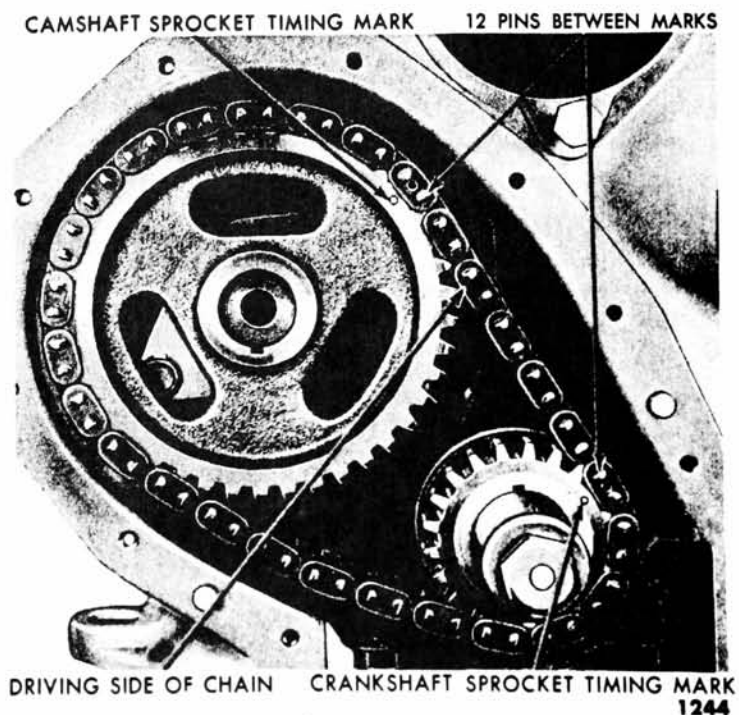

Fig. 16—Aligning Timing Marks

100% SATISFACTION GUARANTEED

BUY IT NOW!

Click Here To Order

PayPal, American Express, Discover, MasterCard, VISA

er and retaining

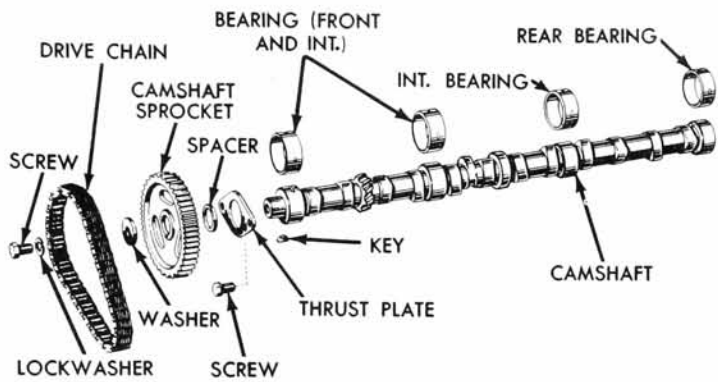

Fig. 17—Camshaft and Related Parts

Remove the rocker arm cover. Disconnect the ignition switch to coil wire from the engine clips, then remove the push rod chamber cover. Remove the rocker arm assembly, then remove the valve push rods in sequence.

Remove the camshaft sprocket bolt. Crank the engine until the timing marks on the sprocket and chain are positioned as shown in fig. 16. Remove the distributor cap, and scribe a line on the distributor housing and cylinder block to mark the position of the rotor and distributor housing for installation, then remove the distributor.

Remove the sprockets and timing chain. Remove the camshaft thrust plate, woodruff key, and spacer.

Turn the camshaft until the tappets can be lifted with either a magnet (fig. 18), or the fingers. Raise the tappets clear of the camshaft lobes, and secure them with spring-type clothes pins or window regulator spring clips (figs. 18 and 19).

Carefully remove the camshaft by pulling it toward the front of the engine.

CAUTION: Exercise the necessary caution to avoid damaging the camshaft bearings.



6503

100% SATISFACTION GUARANTEED

BUY IT NOW!

Click Here To Order

PayPal | American Express | Discover | MasterCard | VISA

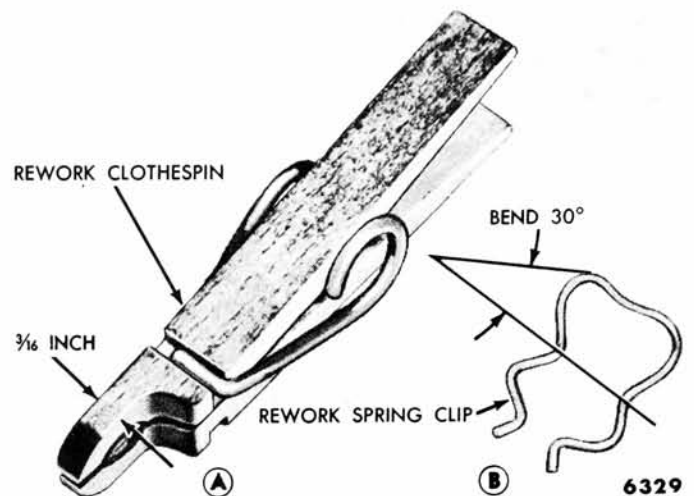

Fig. 19—Tappet Retainers

(2) **INSTALLATION.** Oil the camshaft and carefully slide it through the bearings. Install the thrust plate and spacer.

NOTE: Be sure the chamfer on the inside of the spacer is to the rear or faces the camshaft journal when the spacer is installed.

Tighten the retaining bolts to 12-15 foot-pounds torque. Install the woodruff key in the camshaft.

Check the camshaft end play. If the end play is excessive, inspect the spacer for correct installation. Replace the thrust plate and/or spacer if necessary. Install the sprockets and timing chain, camshaft sprocket washers and bolt, cylinder front cover, crankshaft damper, drive belts, and oil pan.

Install the hub and fan blades, fuel pump, radiator, radiator support bar, and radiator grille.

Release the tappets and install the push rods, then install the rocker arm assembly.

Install the distributor, using the scribed lines as guides to properly position the rotor and housing; make a preliminary valve lash adjustment. Install the distributor cap and carburetor air cleaner. Cement the gasket to the push rod chamber cover and install the cover. Tighten the retaining screws to 15-20 inch-pounds torque.

Run the engine at fast idle and check for oil and coolant leaks. Make a final (hot) valve lash adjustment with the engine idling. Install the rocker arm cover. Check the ignition timing and adjust the timing if necessary.

c. Tappet Replacement.

Remove the camshaft as outlined in "b." Remove and install one tappet at a time through the bottom of the block. A flexible-type holding tool can be used if desired.

As each tappet is installed, it should be secured in the up position.

After the tappets are installed, install the camshaft as outlined in "b."

d. Bearing Replacement.

It will be necessary to remove the engine from the car to replace camshaft bearings. The bearings are available pre-finished to size and require no reaming for standard and 0.015 inch undersize journal diameters. Number 3 bearing is not interchangeable with the other bearings.

Remove the camshaft as outlined in "b." Remove the flywheel and crankshaft. Push the pistons to the top of the cylinders to move the connecting rods out of the way. Knock out the camshaft rear bearing bore plug working from the front bearing bore, or drill a ½ inch hole in the plug and use the tool shown in fig. 20 to remove the plug. Remove the camshaft bearings with the tool shown in fig. 21.

Position the bearing at the bearing bore, and press it in place with the tool shown in fig. 21. Number 1 cam bearing must be pressed in 0.005-0.025 inch below the front face of the bearing bore. Press the remaining bearings in sufficiently to align the oil supply holes.

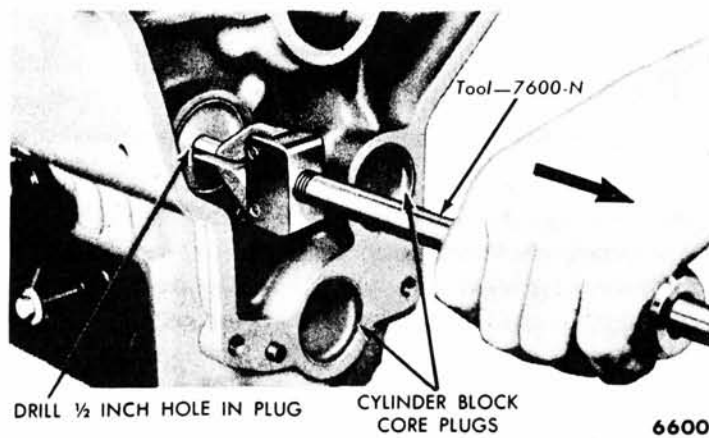

Fig. 20—Camshaft Bore Plug Removal

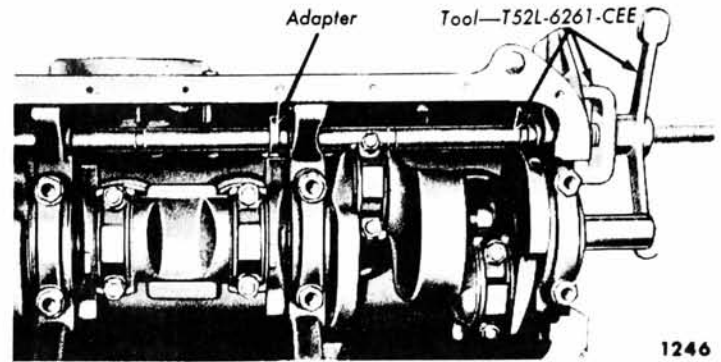

Fig. 21—Camshaft Bearings—Removal or Installation

Clean out the plug recess in the camshaft rear bore. Lightly coat the outer rim of a new plug with sealer. Install the plug with the tool shown in fig. 22.

Install the camshaft as outlined in "b." Install the crankshaft and flywheel, then install the engine in the car.

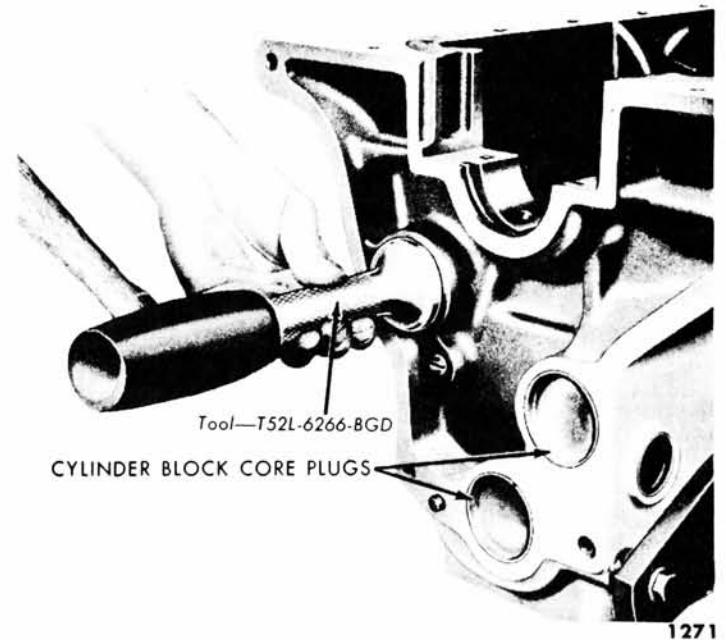

Fig. 22—Camshaft Bore Plug Installation

7. FLYWHEEL, CRANKSHAFT, AND MAIN BEARINGS

The crankshaft and related parts are shown in fig. 23. The procedure for replacing the clutch pilot bushing is covered in Part TWO.

a. Flywheel.

The flywheel is piloted on a shoulder and is retained in one position as the ring gear is

On cars equipped with a standard or overdrive transmission, the rear face of the flywheel is used as a friction surface which is engaged by the clutch disc. The flywheel can be removed and installed with the engine mounted in the car.

The flywheel used on Fordomatic equipped cars has two laminated spring-steel drive plates riveted to the outer edge 180° apart, to which the converter cover is attached.

(1) REMOVAL — STANDARD OR OVERDRIVE

100% SATISFACTION GUARANTEED

BUY IT NOW!

Click Here To Order

PayPal American Express Discover MasterCard VISA

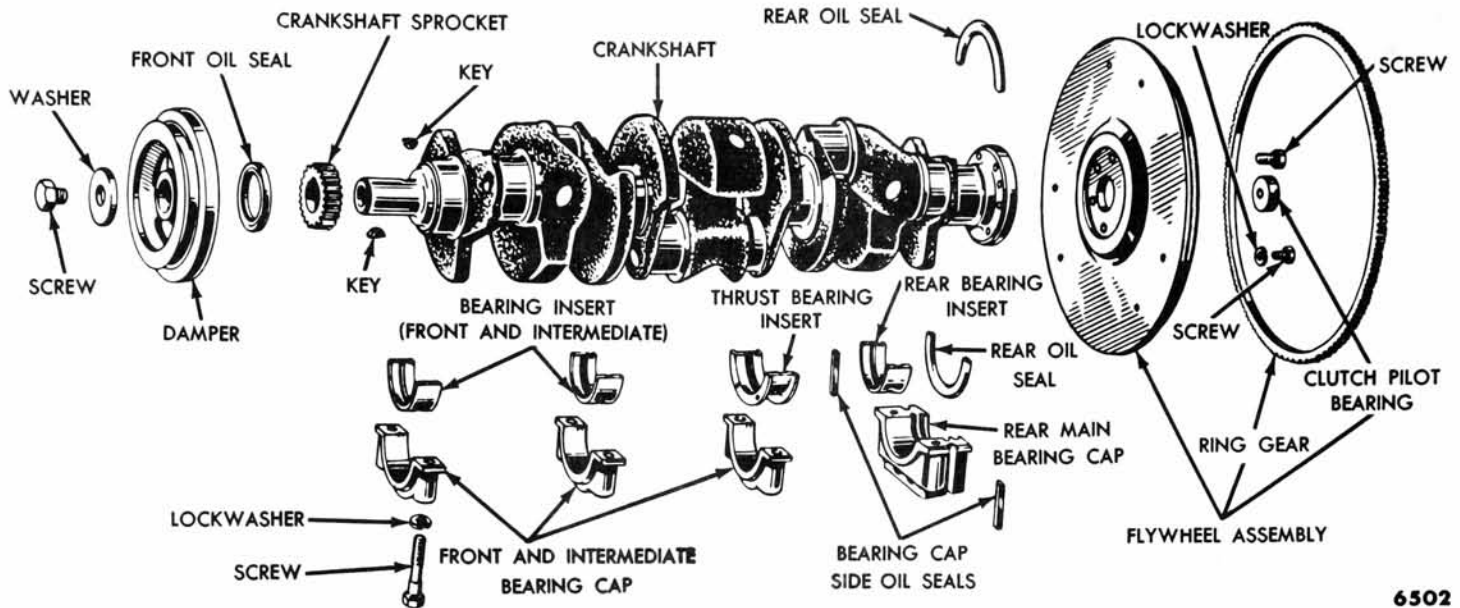

Fig. 23—Crankshaft and Related Parts

6502

TRANSMISSION. Remove the transmission. Remove the flywheel housing dust cover. Mark the clutch assembly so it can be replaced in the same position. Remove the clutch release rod, spring, and bearing. Remove the clutch pressure plate and disc (Tool-7563). Remove the flywheel retaining bolts and pry the flywheel off the crankshaft. Remove the flywheel through the housing lower access opening.

CAUTION: Do not get grease or oil on the clutch components.

(2) **INSTALLATION — STANDARD OR OVER-DRIVE TRANSMISSION.** Position the flywheel on the crankshaft flange and align the bolt holes, then install the mounting bolts. Tighten the bolts in sequence across from each other to 75-85 foot-pounds torque. Using a pilot shaft (Tool-6392-N) to locate the clutch disc, install the pressure plate and disc. Install the clutch release rod, bearing, spring, and hub. Install the flywheel housing dust cover. Install the transmission.

(3) **REMOVAL—FORDOMATIC.** Remove the two rubber plugs from the floor pan, then remove the converter housing to engine block upper bolts. Raise the front of the car and position safety stands. Remove the transmission control linkage shield, the torque converter lower access plate, the torque converter air inlet shield, and the torque converter front access plate. Turn the torque converter until the drain plug is at the lower edge. Drain the transmission and torque converter.

Remove the drive shaft. Disconnect the speedometer cable from the transmission control rod at the transmission. Remove the floor pan, then remove the torque converter oil level indicator tube. Position the torque converter. Posi-

tion a jack under the transmission. Remove the transmission support bolts. Remove the frame cross member at the rear of the transmission. Remove the two lower bolts securing the torque converter housing to the engine block. Move the transmission back far enough to clear the flex drive plate. Secure the torque converter to the housing.

CAUTION: If the torque converter is not secured, it will slide off the splines.

Remove the flex drive plate from the crankshaft.

(4) **INSTALLATION—FORDOMATIC.** Position the flex drive plate on the crankshaft and align the bolt holes, then install the mounting bolts. Tighten the bolts to 75-85 foot-pounds torque. Align the converter pilot and the housing dowel holes, then install the torque converter housing to engine block lower bolts. Install the flex plate to converter bolts. Install the frame cross member. Remove the jack. Install the transmission rear support bolts.

Connect the transmission throttle control linkage, the manual control linkage, and the speedometer cable. Install the torque converter air inlet shield, control linkage shield, torque converter housing front access cover, the torque converter lower access cover, and the transmission oil level indicator tube.

Install the starter, then connect the battery cable to the starter. Install the drive shaft. Remove the safety stands and lower the car. Install the converter housing to engine block bolts. Install the rubber plugs and position the floor mat.

Fill the transmission with fluid. Start the engine to fill the torque converter, then add fluid until the proper level is reached on the oil level indicator. Check for

100% SATISFACTION GUARANTEED

BUY IT NOW!

Click Here To Order

PayPal American Express Discover Novus MasterCard VISA

leaks. Check and adjust the manual control, the neutral switch, and the throttle linkage.

b. Crankshaft.

The crankshaft is precision-molded, alloy iron with integral counterweights and is statically and dynamically balanced. Oil distribution holes are drilled through the shaft to pressure lubricate the main and connecting rod bearings.

NOTE: *Handle the crankshaft with care to avoid possible fractures or damage to the finished surfaces.*

(1) **REMOVAL.** Remove the engine and install it on a work stand. Remove the flywheel housing, clutch assembly, flywheel or flex drive plate, and the engine rear plate. Mark the clutch pressure plate assembly so it can be installed in the same position on the flywheel. Remove the crankshaft damper, cylinder front cover, sprockets and timing chain. Remove the oil pan and the oil pump screen housing assembly.

Make sure all bearing caps (main and connecting rod) are marked so they can be installed in their original locations. Remove the connecting rod bearing caps, using care not to intermix the caps, then push the pistons to the top of the cylinders.

Remove the main bearing caps, and mark them for installation on the same journals. Carefully lift the crankshaft out of the block so the thrust bearing surfaces are not damaged. Remove the rear journal oil seal from the block and rear bearing cap, and remove the cap to block side seals.

(2) **INSTALLATION.** Be sure the bearings and the crankshaft journals are clean. Install a new rear journal oil seal in the block and rear main bearing cap. Carefully lower the crankshaft into place.

CAUTION: *Be careful not to damage the bearing surfaces.*

Check the clearance of each main bearing using Plastigage (Chapter I). After the clearance has been checked and found to be satisfactory, apply a light coat of engine oil to the journals and bearings, then install all the bearing caps except the thrust bearing cap. Install new side seals when the rear main bearing cap is installed. Install the thrust bearing cap and draw the cap bolts up lightly, then align the thrust bearing (Chapter I). Tighten the cap bolts to specifications. Check the crankshaft end play (Chapter I).

Install the connecting rod caps in their original position using Plastigage. After the clearance has been checked and found to be satisfactory, apply a light coat of engine oil to the journals and bearings, then install the rod

caps. Tighten the nuts to 45-50 foot-pounds torque. Install the pal nuts and tighten them to 3-4 foot-pounds torque. Check the end play of each connecting rod (Chapter I).

Install the engine rear plate. Install the flywheel or flex drive plate. Align the clutch disc (Tool-6392-N), compress the clutch pressure plate springs, and install the pressure plate assembly. Install the flywheel housing. Install the sprockets and timing chain. Install the cylinder front cover, oil pump screen assembly and oil pan, the crankshaft damper, and belt.

On cars equipped with power steering, install the power steering pump pulley and belt.

Install the engine in the car. Fill the crankcase, then start the engine and check for oil pressure and oil leaks.

c. Main Bearings.

The main bearings are the steel-backed, copper-lead, or lead-babbitt insert-type.

Crankshaft end play is controlled by the number 3 main bearing flanges.

If the crankshaft has been removed, new bearings can be readily fitted. However, the bearings can be fitted with the engine in the chassis as follows:

Remove the oil pan, then remove the oil pump.

NOTE: *Replace one bearing at a time, leaving the other bearings securely fastened.*

Remove the main bearing cap to which new bearings are to be fitted. Insert the upper bearing removal tool (Tool 6-331) in the oil hole in the crankshaft. Rotate the crankshaft in the opposite direction to engine rotation to force the bearing out of the block.

NOTE: *When replacing standard bearings with new bearings, it is good practice to first try to obtain the proper clearance with two blue bearing halves.*

To install the upper main bearing, place the plain end of the bearing over the shaft on the locking tang side of the block. Using the same tool, rotate the crankshaft in the direction of engine rotation until the bearing seats itself. Remove the tool. Replace the bearing cap.

Clean the crankshaft journal and bearings. Check the bearing clearance using Plastigage (Chapter I). After the clearance has been checked and found to be satisfactory, apply a light coat of engine oil to the journals and bearings, then install the bearing cap. Tighten the bolts to 95-105 foot-pounds torque.

If the rear main bearing is replaced, replace the journal oil seals and the side seals.

Install the oil pump and oil pan. Fill the crankcase, then start the engine and check for oil pressure and oil leaks.

100% SATISFACTION GUARANTEED

BUY IT NOW!

Click Here To Order

PayPal American Express Discover MasterCard VISA

8. CONNECTING RODS AND BEARINGS, PISTONS, PINS, AND RINGS

The piston and connecting rod are shown disassembled in fig. 24.

a. Piston and Connecting Rod Removal.

Remove the oil pan and cylinder head. Before removing the piston assemblies, remove any ridge and/or carbon deposits from the upper end of the cylinder bores. Move the piston to the bottom of its travel and place a cloth on the piston head to collect the cuttings. Remove the cylinder ridge with a ridge cutter. Follow the instructions furnished by the tool manufacturer.

CAUTION: *Never cut into the ring travel area in excess of 1/32 inch when removing ridges.*

After the ridge has been removed, remove the cutter from the cylinder bore, then turn the crankshaft until the position is at the top of its stroke and carefully remove the cloth with the cuttings.

Turn the crankshaft until the connecting rod being removed is down. Remove the pal nuts and the hex head nuts from the connecting rod bolts. Pull the cap off the rod, then push the rod and piston assembly out the top of the cylinder with the handle end of a hammer.

CAUTION: *Avoid damage to the crankpin or the cylinder wall when removing the piston and rod.*

Remove the glaze from the cylinder wall (Chapter I). Repeat this procedure for each assembly.

NOTE: *Each rod and bearing cap is numbered from 1 to 6 from the front to the rear of the engine. The numbers on the rod and bearing cap must be on the same side when installed in the cylinder bore. If a connecting rod is ever transposed from one block or cylinder to another, new bearings should be fitted, and the rod should be numbered to correspond with the new cylinder number.*

b. Piston and Connecting Rod Disassembly.

Mark the pistons and pins to assure assembly with the same rod and installation in the same cylinder from which they were removed. Remove the piston rings.

Remove the piston pin retainers, then drive the pin out of the piston and rod (fig. 25). Discard the retainers.

c. Piston and Connecting Rod Assembly.

Lubricate all parts with light engine oil.

NOTE: *Assemble the piston and connecting rod with the oil squirt hole in the rod positioned as shown in fig. 26.*

Position the connecting rod in the piston and push the pin into place.

Insert new piston pin retainers by spiraling them into the piston with the fingers. Do not use pliers.

Follow the instructions contained in the piston ring package and install the piston rings.

Be sure the bearings and journals are clean. If it is necessary to replace the connecting rod bearings, replace them at this time.

d. Piston and Connecting Rod Installation.

Oil the piston rings, pistons, and cylinder walls with light engine oil.

NOTE: *Be sure to install the pistons in the same cylinder from which they were removed, or to which they were fitted.*

Make sure the ring gaps are properly spaced around the circumference of the piston. Install a piston ring compressor on the piston and push the piston in with a hammer (fig. 27) until it is slightly below the top of

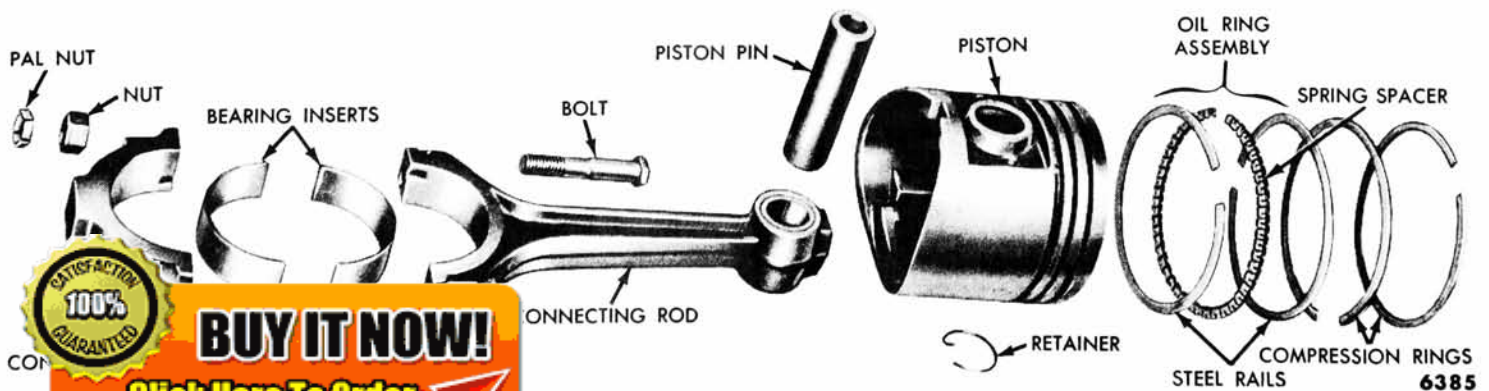

Piston and Connecting Rod Disassembled

CON

100% GUARANTEED

BUY IT NOW!

Click Here To Order

PayPal

MasterCard

VISA

the cylinder. Be sure to guide the connecting rods to avoid damaging the crankshaft journals.

NOTE: *Install the piston with the indentation in the piston head toward the front of the engine.*

Check the bearing clearance using Plastigage (Chapter I). After the clearance has been checked, and found satisfactory, apply a light coat of engine oil to the journals and bearings. Turn the crankshaft throw to the bottom of its stroke, then push the piston all the way down until the rod bearing seats on the crankpin. Install the rod cap, then tighten the bolts to 45-50 foot-pounds torque. Install the pal nuts and tighten them to 3-4 foot-pounds torque.

After all the piston and rod assemblies have been installed, check the end play of the connecting rods (Chapter I).

Install the oil pan and cylinder head. Fill the crankcase with the proper grade and amount of lubricant. Fill the cooling system. Run the engine at fast idle. Make sure there is sufficient oil pressure and the engine does not overheat. Check for oil and coolant leaks.

e. Connecting Rod Bearing Replacement.

If the engine is removed and mounted on a stand, the bearings can be readily fitted. However, the bearings can be fitted without removing the engine as follows:

Remove the oil pan, then remove the oil pump.

Remove the connecting rod bearing caps to which new bearings are to be fitted. Push the piston up in the cylinder, then remove the upper and lower bearings.

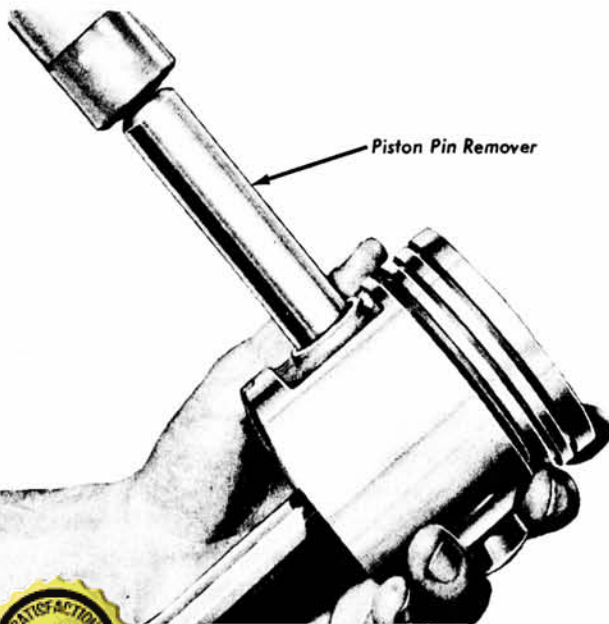

6386

100% SATISFACTION GUARANTEED

BUY IT NOW!

Click Here To Order

PayPal, American Express, Discover, MasterCard, VISA

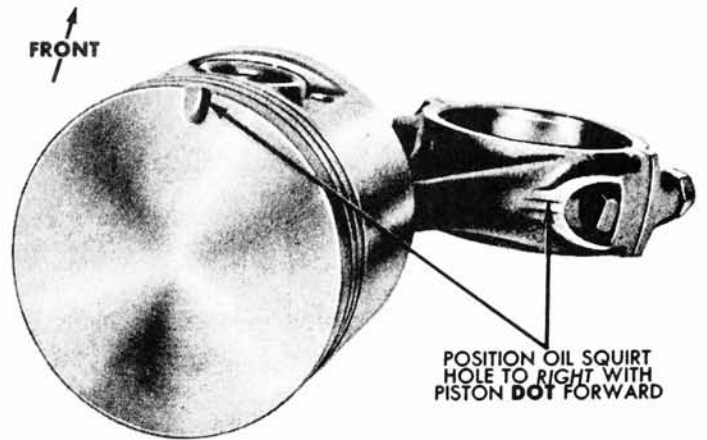

6387

Fig. 26—Correct Position of Oil Squirt Hole

Clean the crankshaft journal, the cap, and the upper half of the bearing bore.

NOTE: *When replacing standard bearings with new bearings, it is good practice to first try to obtain the proper clearance with two blue bearing halves.*

Install the new bearings in the rod and cap. Check the fit using Plastigage (Chapter I). After the bearing fit has been checked and found to be satisfactory, apply a light coat of engine oil to the journals and bearings, then install the rod cap. Tighten the bolts to 45-50 foot-pounds torque. Install the pal nuts, and tighten them to 3-4 foot-pounds torque. Repeat the procedure for the remaining bearings that need replacing.

After all the bearings have been replaced, install the oil pump and oil pan. Fill the crankcase, then operate the engine and check for oil pressure and oil leaks.

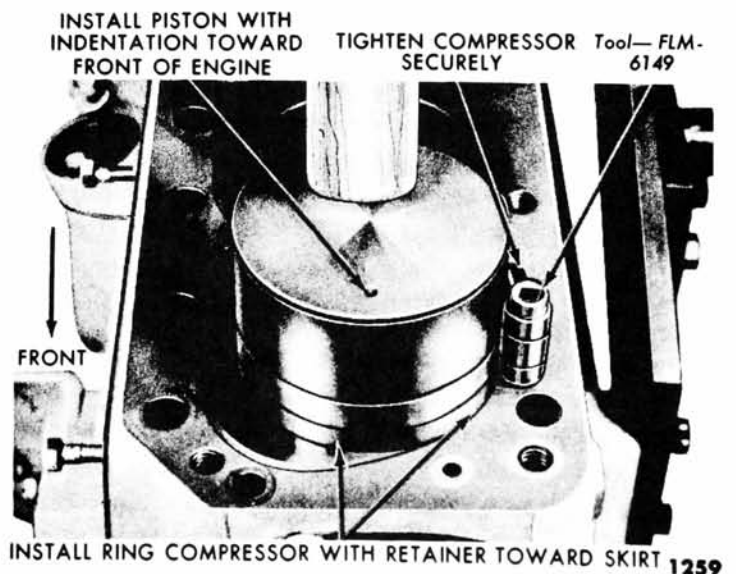

Fig. 27—Piston Installation

1259

9. OIL PAN, OIL FILTER, AND OIL PUMP

Procedures for the removal and installation of the above components are presented below.

a. Oil Pan.

(1) **REMOVAL.** Drain the crankcase. Remove the oil level indicator. Remove the engine left and right front splash aprons.

Remove the flywheel housing inspection cover. Remove the oil pan retaining screws and remove the pan and gasket.

(2) **INSTALLATION.** Make sure the gasket surfaces of the block and pan are clean and free from burrs. Coat the block surface and oil pan gasket surface with sealer and position the gasket on the oil pan. Hold the pan in place against the block and install a screw, finger tight, at each end of the pan. Install the remaining screws, then tighten the screws from the center outward in each direction to 12-15 foot-pounds torque.

Install the flywheel housing inspection cover. Install the engine right and left front splash aprons.

Install the oil level indicator. Fill the crankcase with the proper grade and quantity of engine oil. Run the engine and check for oil leaks.

b. Oil Filter.

The full flow-type oil filter (fig. 28) filters the entire output of the pump before the oil enters the engine lubrication system.

A built in by-pass provides oil to the system in case the filter element becomes clogged. The by-pass is located in the hollow center bolt and consists of a spring loaded valve. When the element is clean and oil will flow through it, the pressure difference between the inner and outer faces of the valve is not great enough to overcome the spring pressure behind the valve. Therefore, no oil flows through the by-pass. When the element is dirty and will not permit a sufficient flow of oil, the oil pressure acting on the inner face of the valve drops. If the pressure difference between the valve faces is great enough to overcome the spring pressure, the valve will open. Oil then by-passes the element, thereby maintaining an emergency supply of oil to the

engine lubrication system until the source of restriction to the normal oil flow is corrected.

(1) **REMOVAL.** Remove the filter from the bottom of the car. Place a drip pan under the filter. Remove the filter center bolt, then remove the filter assembly and gasket.

(2) **DISASSEMBLY.** Remove the filter element, neoprene gasket, spring, and seat, then remove the center bolt from the container and the fiber gasket from the bolt. Discard the filter element and all gaskets. Wash all parts in solvent. Make sure all the openings in the center bolt are clean.

(3) **ASSEMBLY.** Install a new fiber gasket on the center bolt, then place the bolt through the filter container. Install the spring and spring seat assembly on the bolt, making sure the seat tangs are engaged in the spring. Install a new neoprene gasket and a new filter element over the center bolt.

(4) **INSTALLATION.** Check to see if the two elongated holes in the oil filter anti-drain back diaphragm are in the up position as shown in fig. 29. Clean the cylinder block filter recess, then install a new gasket. Place the filter assembly in position, and thread the center bolt into the adapter finger-tight. Rotate the filter assembly slightly, in each direction, to make sure the gasket is seated evenly. Tighten the center bolt to 20-25 foot-pounds torque.

CAUTION: Do not over tighten the center bolt.

Refill the crankcase with oil if necessary, then operate the engine at fast idle, and check for leaks. If oil leaks are evident, perform the necessary repairs to correct the leakage.

c. Oil Pump.

A gear-type oil pump is mounted inside the crankcase in line with the distributor.

The pump is driven by means of an intermediate hex shaped drive shaft. The shaft is pinned into the end of the distributor drive shaft.

(1) **REMOVAL.** Remove the distributor, oil level indicator, and the oil pan. Remove the two nuts and lockwashers retaining the pump to the cylinder block. Remove the pump and gasket. Thoroughly clean the old gasket material from the mounting pad on the block and pump.

(2) **DISASSEMBLY.** Remove the screen assembly retaining screws, the screen assembly, and gasket. Remove the cover retaining screws, cover, and gasket. Push the pump drive shaft and drive gear assembly from the pump housing. Remove the driven gear. Remove the oil pressure relief valve chamber plug, spring, and plunger.

The diagram shows the components of an oil filter assembly. Labels include: CENTER TUBE BOLT, FILTER HOUSING, SPRING, SPRING RETAINER, FIBER GASKET, NEOPRENE GASKET, GASKET, ADAPTER FITTING, and OIL BACK. A yellow banner at the bottom left says '100% SATISFACTION GUARANTEED' and 'BUY IT NOW! Click Here To Order'. Below the banner are logos for PayPal, American Express, Discover, MasterCard, and VISA.

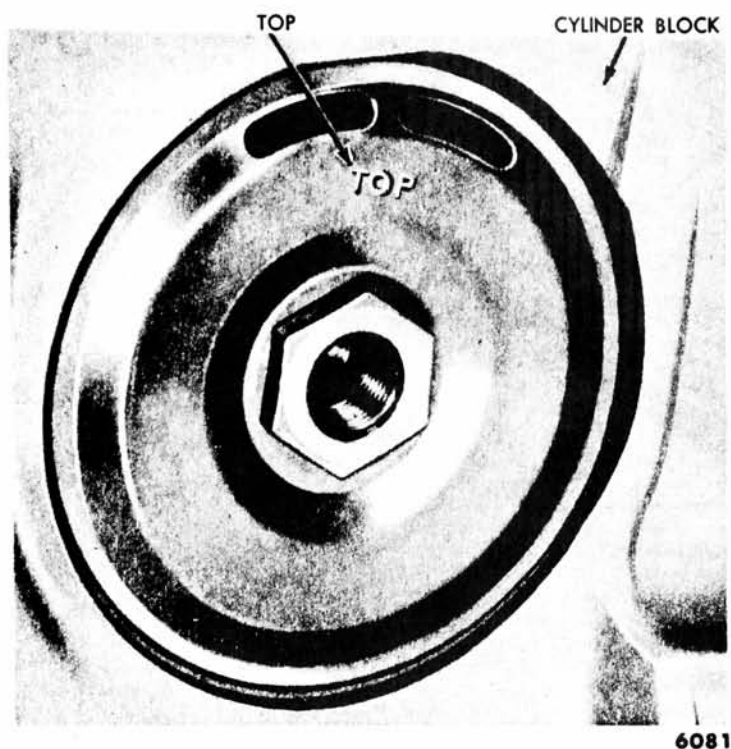

Fig. 29—Oil Filter Anti-Drain Back Diaphragm Position

Remove the snap wire retaining the pump screen, and remove the screen from the housing. The oil pump and screen are shown disassembled in fig. 30.

(3) **ASSEMBLY.** Apply a light coat of engine oil to all moving parts.

Install the pressure relief valve plunger, spring, and plug. Tighten the plug to 33-38 foot-pounds torque.

Slide the drive gear and shaft assembly into the housing. Install the driven gear. Check the end play of the gears using Plastigage or a dial indicator (Chapter I). Apply sealer to both sides of the pump cover gasket, then position the gasket on the pump. Install the pump cover, but do not tighten the retaining screws. Install

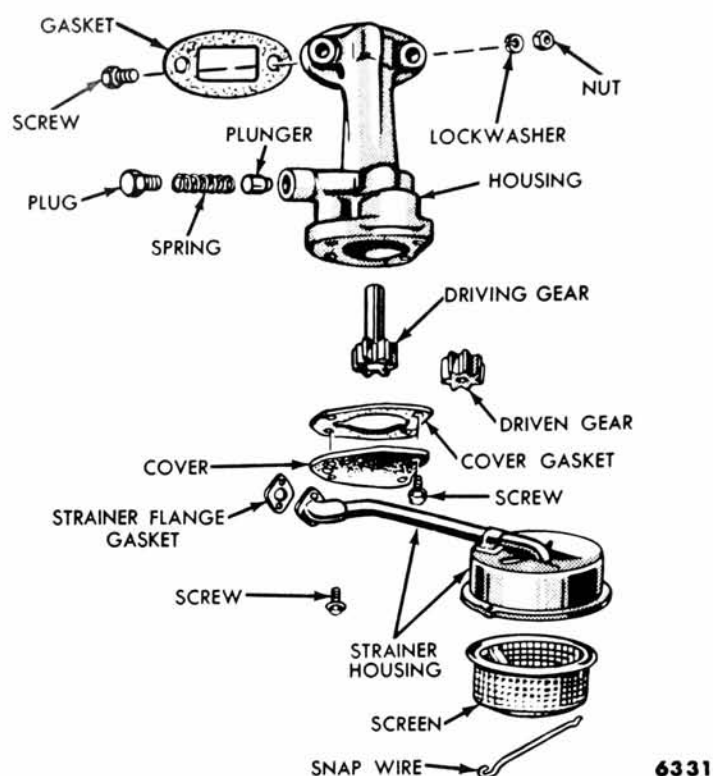

Fig. 30—Oil Pump Disassembled

the screen in the screen cover and secure it with the retainer. Install the inlet tube gasket, and the screen and inlet tube assembly on the pump cover. Tighten the retaining screws to 12-15 foot-pounds torque. Rotate the pump shaft by hand to make sure it turns freely.

(4) **INSTALLATION.** Place a new gasket on the retaining bolts, slide the pump mounting flange over the retaining bolts, and install the lock washers and nuts. Tighten the nuts to 30-35 foot-pounds torque. Install the distributor.

Install the oil pan. Fill the crankcase with the proper grade and quantity of oil.

Run the engine at fast idle and check for oil pressure and oil leaks.

10. EXHAUST SYSTEM

The exhaust system consists of a muffler, a muffler outlet pipe, and a muffler inlet pipe (fig. 31). These parts are provided as individual service parts.

NOTE: When replacing any part of the exhaust system, loosen all the frame attaching bracket clamps to relieve twists in the system, then tighten the clamps.

Muffler Replacement.

...ected mufflers are
let pipe to frame
half of the clamp

at the rear of the muffler. Separate the outlet pipe and muffler, by sliding the outlet pipe to the rear. Loosen the muffler inlet pipe clamp and slide the clamp away from the muffler. Separate the muffler from the inlet pipe, then remove the muffler.

(2) **INSTALLATION.** Position the new muffler and clamp on the inlet pipe. Slide the muffler forward on the inlet pipe until the slots in the muffler extension are blocked. However, do not slide the muffler on the inlet pipe more than 1¾ inches. Align the muffler. Rotate the inlet pipe clamp downward approximately 45° so the clamp opening is not positioned directly opposite the slots in the muffler extension.

100% SATISFACTION GUARANTEED

BUY IT NOW!

Click Here To Order

PayPal American Express Discover MasterCard VISA

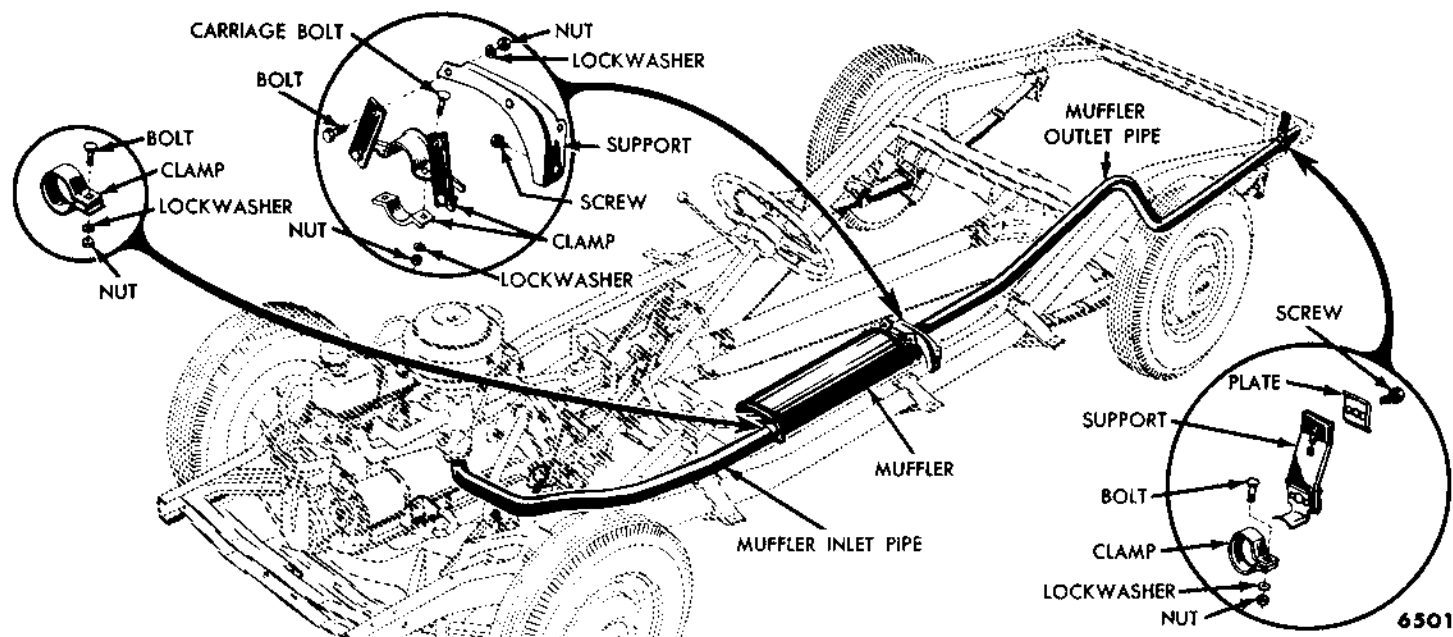

Fig. 31—Exhaust System

Slide the outlet pipe forward into the muffer extension until the slots in the muffer extension are blocked. However, do not slide the pipe into the muffer more than $1\frac{3}{4}$ inches. Connect, but do not tighten, the lower half of the clamp at the rear of the muffer. Check for possible interference between the outlet pipe "kick-up" and the floor pan. Reposition the outlet pipe if necessary. Tighten the outlet pipe clamps.

b. Outlet Pipe Replacement.

The outlet pipe is attached to the frame by flexible sound deadening materials which not only prevent the exhaust noises from being conducted through the chassis frame, but also relieve the exhaust system from twisting or bending stresses.

(1) **REMOVAL.** Remove the lower half of the clamp at the rear of the muffer, then remove the rear clamp from its support. Separate the muffer and outlet pipe.

(2) **INSTALLATION.** Slide the outlet pipe into the muffer extension until the slots in the muffer extension are blocked. However, do not slide the pipe into the muffer more than $1\frac{3}{4}$ inches. Slide the rear clamp on the outlet pipe and connect, but do not tighten it to its support. Connect, but do not tighten, the lower half of the clamp at the rear of the muffer. Check for possible interference between the outlet pipe "kick-up" and the

floor pan. Reposition the outlet pipe if necessary. Tighten the outlet pipe clamps.

c. Inlet Pipe Replacement.

The muffer inlet pipe is designed to give the exhaust gases leaving the exhaust manifolds a direct through passage to the muffer, thereby increasing the over-all efficiency of the exhaust system.

(1) **REMOVAL.** Loosen the outlet pipe clamps and the muffer inlet pipe clamp. Remove the two nuts fastening the inlet pipe to the exhaust manifold. Slide the muffer to the rear, then separate the muffer and inlet pipe. Remove the inlet pipe and gasket.

(2) **INSTALLATION.** Slide the clamp on the new inlet pipe, then slide the inlet pipe into the muffer extension until the slots in the extension are blocked. However, do not slide the pipe into the muffer more than $1\frac{3}{4}$ inches. Install a new gasket on the exhaust manifold outlet flange studs, then connect the inlet pipe to the exhaust manifold. Tighten the bolts to 23-28 foot-pounds torque. Position the muffer, then tighten the outlet pipe clamps. Rotate the inlet pipe clamp downward approximately 45 degrees so the clamp opening is not positioned directly opposite the slots in the muffer extension, then tighten the clamp.

100% SATISFACTION GUARANTEED

BUY IT NOW!

Click Here To Order

PayPal American Express Discover MasterCard VISA



BUY IT NOW!

Click Here To Order



PayPal

AMERICAN EXPRESS
Cards

DISCOVER
NOWUS

MasterCard

VISA

FORM 7098-56