

1 9 5 5

FORD CAR SHOP MANUAL

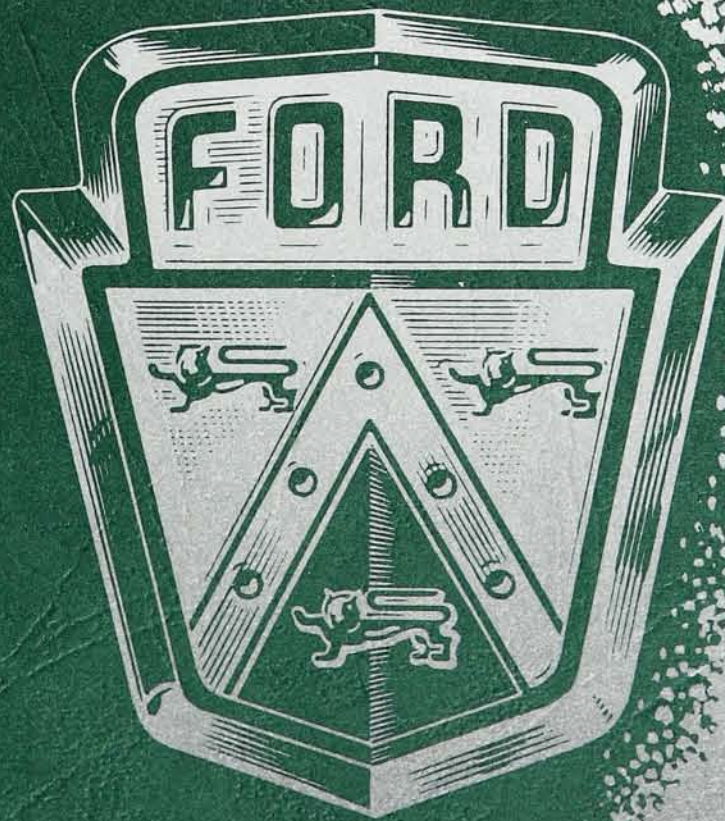

100% SATISFACTORY GUARANTEED
BUY IT NOW!
Click Here To Order

SION • FORD MOTOR COMPANY

Copyright © 2009, Forel Publishing Company, LLC, Woodbridge, Virginia

All Rights Reserved. No part of this book may be used or reproduced in any manner whatsoever without written permission of Forel Publishing Company, LLC. For information write to Forel Publishing Company, LLC, 3999 Peregrine Ridge Ct., Woodbridge, VA 22192

1955 Ford Car Shop Manual

EAN: 978-1-60371-004-6

ISBN: 1-60371-004-3

Forel Publishing Company, LLC

3999 Peregrine Ridge Ct.

Woodbridge, VA 22192

Email address: webmaster@ForelPublishing.com

Website: <http://www.ForelPublishing.com>



This publication contains material that is reproduced and distributed under a license from Ford Motor Company. No further reproduction or distribution of the Ford Motor Company material is allowed without the express written permission of Ford Motor Company.

Note from the Editor

This product was created from the original Ford Motor Company's publication. Every effort has been made to use the original scanned images, however, due to the condition of the material; some pages have been modified to remove imperfections.

Disclaimer

Although every effort was made to ensure the accuracy of this book, no representations or warranties of any kind are made concerning the accuracy, completeness or suitability of the information, either expressed or implied. As a result, the information contained within this book should be used as general information only. The author and Forel Publishing Company, LLC shall have neither liability nor responsibility to any person or entity with respect to any loss or damage caused, or alleged to be caused, directly or indirectly by the information contained in this book. Further, the publisher and author are not engaged in rendering legal or other professional services. If legal, mechanical, electrical, or other expert assistance is required, the professional should be sought.



1 9 5 5

FORD CAR SHOP MANUAL



Copyright 1954
FORD MOTOR COMPANY
DEARBORN, MICHIGAN
All rights reserved



BUY IT NOW!

Click Here To Order



ON • FORD MOTOR COMPANY

November, 1955

FOREWORD

This manual contains complete service information for all 1955 Ford Passenger Cars and the new Ford Thunderbird. Step-by-step procedures for trouble shooting, cleaning and inspecting, repairing, and replacing the various parts, assemblies, and systems on these vehicles are presented here. This manual also contains maintenance and lubrication data as well as a tabulation of service specifications. Detailed illustrations of many of the service operations are given here. Disassembled views of the principal units show the various parts in the order of their disassembly or assembly. In many cases, a glance at these illustrations will tell you all you need to know about how the parts go together.

The material presented in this manual is arranged in five main parts as listed in the Table of Contents on the following pages. Under each part, chapter headings covering the major subjects in each part are given. The section headings under each chapter title indicate the subjects covered in the chapter.

Part ONE—POWER PLANT—has to do with the 6 and 8-cylinder engines and the various systems that are necessary to their operation. These include the fuel, ignition, and cooling systems.

Part TWO—ELECTRICAL AND ACCESSORIES—covers all of the electrical systems and units (except the ignition system) and all of the accessories (except the Overdrive and Fordomatic).

Part THREE—BODIES—contains information on the maintenance and repair of

all body components, including adjustment and alignment of doors, hoods, and fenders. In addition, window glass adjustments are given in this part.

Part FOUR—CHASSIS—contains information on the entire power train (clutch, conventional transmissions, Overdrive, drive lines, rear axles, etc.) and the running gear (frames, springs, suspension, brakes, wheels, tires, steering gear, steering linkages, etc.). Service procedures for the Fordomatic transmission are published in a separate manual.

Part FIVE—MAINTENANCE AND SPECIFICATIONS—gives complete maintenance and lubrication information, and contains all the specifications necessary for the proper servicing of Ford Cars.

Throughout this manual, the top of each left-hand, even-numbered page gives the name of the chapter, and the top of each right-hand, odd-numbered page gives the name of the section involved on the page. Thus, wherever you open the manual, a glance at the top of the two pages will tell you exactly what subject matter is discussed at that point.

This manual has been prepared to help you in doing a good servicing job on Ford Cars. Keep your manual where it will be readily available for reference at all times.

FORD DIVISION
FORD MOTOR COMPANY
SERVICE DEPARTMENT



TABLE OF CONTENTS

| | | |
|---------------|------|---|
| Foreword..... | Page | 2 |
|---------------|------|---|

Part ONE—POWER PLANT

CHAPTER I—GENERAL ENGINE REPAIR

| | Page | | Page | | |
|-----------|---|----|-----------|--|----|
| Section 1 | Trouble Shooting..... | 5 | Section 7 | Flywheel, Crankshaft, Main Bearings, and Connecting Rod Bearings..... | 19 |
| 2 | Engine Tune-Up..... | 8 | 8 | Oil Pan, Oil Filter, and Oil Pump and Pressure Relief Valve..... | 23 |
| 3 | Engine Removal and Installation..... | 10 | 9 | Cylinder Block, Pistons, Piston Rings, and Connecting Rods..... | 24 |
| 4 | Intake and Exhaust Manifolds..... | 13 | 10 | Exhaust System..... | 27 |
| 5 | Rocker Mechanism, Cylinder Head, Valves, Valve Lash Adjustment, and Valve Timing.. | 14 | | | |
| 6 | Camshaft Sprocket, Camshaft and Camshaft Bearings..... | 18 | | | |

CHAPTER II—6-CYLINDER 223 CUBIC INCH (EBP) ENGINES

| | | | | | |
|-----------|--|----|-----------|---|----|
| Section 1 | Engine Front Steady Rest..... | 28 | Section 5 | Crankshaft Damper, Cylinder Front Cover, and Oil Seal..... | 33 |
| 2 | Manifolds..... | 29 | 6 | Camshaft Sprocket, Camshaft and Bearings... | 34 |
| 3 | Cylinder Heads and Valves..... | 30 | 7 | Flywheel, Crankshaft, and Bearings..... | 36 |
| 4 | Oil Pan and Oil Pump and Pressure Relief Valve..... | 32 | 8 | Connecting Rods, Pistons, Pins, and Rings..... | 37 |
| | | | 9 | Exhaust System..... | 39 |

CHAPTER III—8-CYLINDER 272 (ECG and ECH) AND 292 (ECJ and INTERCEPTOR) CUBIC INCH ENGINES

| | | | | | |
|-----------|--|----|-----------|---|----|
| Section 1 | Manifolds..... | 42 | Section 5 | Timing Chain, Sprockets, Camshaft, Tappets and Bearings..... | 48 |
| 2 | Cylinder Heads and Valves..... | 44 | 6 | Flywheel, Crankshaft and Bearings..... | 51 |
| 3 | Oil Pan and Oil Pump and Pressure Relief Valve..... | 46 | 7 | Connecting Rods, Pistons, Pins, and Rings..... | 53 |
| 4 | Crankshaft Damper, Pulley and Cylinder Front Cover..... | 47 | 8 | Exhaust System..... | 55 |

CHAPTER IV—IGNITION, FUEL, AND COOLING SYSTEMS

| | | | | | |
|-----------|---|----|-----------|---|----|
| Section 1 | Ignition System..... | 57 | Section 7 | Carburetor Operation, Adjustment and Overhaul—Four-Barrel..... | 81 |
| 2 | Distributor Minor Repair and Adjustments.... | 61 | 8 | Fuel Pumps and Vacuum Booster..... | 92 |
| 3 | Distributor Overhaul..... | 64 | 9 | Fuel Tanks and Lines..... | 94 |
| 4 | Carburetor Operation and Adjustments— Single and Two-Barrel Carburetors..... | 70 | 10 | Fans and Belts..... | 95 |
| 5 | Carburetor Overhaul—6-Cylinder Engine..... | 75 | 11 | Water Pumps..... | 96 |
| 6 | Carburetor Overhaul and Adjustment— Two-Barrel Carburetors..... | 78 | 12 | Radiator, Hoses, and Thermostats..... | 98 |

Part TWO—ELECTRICAL AND ACCESSORIES

CHAPTER I—GENERATING SYSTEM AND BATTERY

| | | | | | |
|-----------|-----------------------|-----|-----------|--------------------------|-----|
| Section 1 | Trouble Shooting..... | 101 | Section 3 | Generator Regulator..... | 111 |
| 2 | Generator..... | 105 | 4 | Battery..... | 116 |

CHAPTER II—STARTING SYSTEM

| | | | | | |
|-----------|--------------------------|-----|-----------|--------------------|-----|
| Section 1 | Trouble Shooting..... | 120 | Section 3 | Starter Drive..... | 128 |
| 2 | Starter and Circuit..... | 123 | | | |

CHAPTER III—LIGHTING SYSTEM, HORNS AND INSTRUMENTS

| | | | | | |
|-----------|-----------------------|-----|-----------|------------------|-----|
| Section 1 | Trouble Shooting..... | 130 | Section 3 | Horns..... | 138 |
| 2 | Lighting System..... | 133 | 4 | Instruments..... | 139 |

CHAPTER IV—ACCESSORIES

| | | | | | |
|--|--|-----|-----------|--------------------------------|-----|
| | | 143 | Section 4 | Windshield Wiper..... | 154 |
| | | 146 | 5 | Miscellaneous Accessories..... | 155 |
| | | 151 | | | |



Part THREE—BODIES

CHAPTER I—BODY CONSTRUCTION AND MAINTENANCE

| | | Page | | | Page |
|-----------|---|------|-----------|------------------------------------|------|
| Section 1 | Construction Details and Sealer Application . . . | 157 | Section 4 | Quarter Panel Repair | 167 |
| 2 | Undercoating the Body | 163 | 5 | General Body Maintenance | 169 |
| 3 | Body Alignment | 166 | | | |

CHAPTER II—TRIM, UPHOLSTERY, AND WINDOW GLASS

| | | | | | |
|-----------|--|-----|-----------|--------------------------------------|-----|
| Section 1 | Door and Quarter Trim Panels | 171 | Section 5 | Door Glass | 179 |
| 2 | Headlining Replacement | 174 | 6 | Quarter Glass | 183 |
| 3 | Window Regulators | 176 | 7 | Windshield and Rear Window | 188 |
| 4 | Door Ventilator Assembly | 178 | | | |

CHAPTER III—REMOVABLE SHEET METAL ASSEMBLIES

| | | | | | |
|-----------|---|-----|-----------|--|-----|
| Section 1 | Door Replacement and Alignment | 193 | Section 5 | Grille and Hood | 203 |
| 2 | Door Locking Mechanism | 196 | 6 | Hood Alignment and Lock Adjustment | 205 |
| 3 | Luggage Compartment Door Replacement and Alignment | 199 | 7 | Thunderbird Grille and Hood | 207 |
| 4 | Luggage Compartment Door Locking Mechanism | 201 | 8 | Front Fenders | 208 |

CHAPTER IV—POWER INSTALLATIONS AND SPECIAL ITEMS

| | | | | | |
|-----------|---------------------------|-----|-----------|---|-----|
| Section 1 | Power Windows | 211 | Section 4 | Care of Country Squire Paneling | 224 |
| 2 | Power Seats | 215 | 5 | Crown Victoria Transparent Top | 225 |
| 3 | Convertible Top | 219 | | | |

Part FOUR—CHASSIS

CHAPTER I—CLUTCH, 3-SPEED STANDARD TRANSMISSION, AND GEAR SHIFT LINKAGE

| | | | | | |
|-----------|----------------------------|-----|-----------|---|-----|
| Section 1 | Trouble Shooting | 229 | Section 3 | 3-Speed Standard Transmission | 233 |
| 2 | Clutch | 230 | 4 | Gear Shift Linkage | 238 |

CHAPTER II—OVERDRIVE TRANSMISSION

| | | | | | |
|-----------|---|-----|-----------|----------------------------|-----|
| Section 1 | Overdrive Operating Principles—Mechanical | 240 | Section 3 | Trouble Shooting | 243 |
| 2 | Overdrive Operating Principles—Electrical | 242 | 4 | Overhaul | 245 |

CHAPTER III—REAR AXLES AND DRIVE LINES

| | | | | | |
|-----------|--|-----|-----------|---|-----|
| Section 1 | Trouble Shooting | 252 | Section 3 | Integral Housing Hypoid Rear Axle | 260 |
| 2 | Banjo Housing Hypoid Rear Axle | 252 | 4 | Drive Lines | 265 |

CHAPTER IV—RUNNING GEAR

| | | | | | |
|-----------|----------------------------|-----|-----------|-----------------------------|-----|
| Section 1 | Trouble Shooting | 267 | Section 6 | Shock Absorbers | 278 |
| 2 | Wheel Alignment | 269 | 7 | Steering Gear | 279 |
| 3 | Frames | 271 | 8 | Steering Linkage | 284 |
| 4 | Front Suspension | 273 | 9 | Wheels and Tires | 286 |
| 5 | Rear Springs | 277 | 10 | Hubs and Bearings | 289 |

CHAPTER V—POWER STEERING

| | | | | | |
|-----------|---|-----|-----------|--------------------|-----|
| Section 1 | Construction and Operation | 292 | Section 3 | Overhaul | 302 |
| 2 | Inspection and Trouble Shooting | 299 | | | |

CHAPTER VI—BRAKES

| | | | | | |
|-----------|----------------------------|-----|-----------|----------------------------|-----|
| Section 1 | Trouble Shooting | 316 | Section 5 | Brake Assemblies | 325 |
| 2 | Adjustments | 317 | 6 | Brake Drums | 326 |
| 3 | Hydraulic System | 319 | 7 | Parking Brakes | 326 |
| 4 | Power Brakes | 322 | | | |

Part FIVE—MAINTENANCE AND SPECIFICATIONS

CHAPTER I—MAINTENANCE

| | | | | | |
|-----------|----------------------------------|-----|-----------|-----------------------|-----|
| Section 1 | Preventive Maintenance | 329 | Section 2 | Lubrication | 331 |
|-----------|----------------------------------|-----|-----------|-----------------------|-----|

CHAPTER II—SPECIFICATIONS

| | | | | | |
|-----------|--|-----|-----------|-------------------------------|-----|
| Section 1 | Wheels and Tires | 334 | Section 8 | Cooling | 338 |
| 2 | Brakes | 334 | 9 | Fuel System | 339 |
| 3 | Wheel Alignment and Steering | 335 | 10 | Generating System | 339 |
| | Rear Axle | 335 | 11 | Starting System | 339 |
| | | 336 | 12 | Ignition | 340 |
| | | 336 | 13 | Lights and Horns | 340 |
| | | 338 | 14 | Tools and Equipment | 340 |



Part ONE

POWER PLANT

Chapter I

General Engine Repair

| Section | Page |
|---|------|
| 1. Trouble Shooting | 5 |
| 2. Engine Tune Up | 8 |
| 3. Engine Removal and Installation | 10 |
| 4. Intake and Exhaust Manifolds | 13 |
| 5. Rocker Mechanism, Cylinder Head, Valves, Valve Lash Adjustment, and Valve Timing | 14 |
| 6. Camshaft Sprocket, Camshaft, and Camshaft Bearings | 18 |
| 7. Flywheel, Crankshaft, Main Bearings, and Connecting Rod Bearings | 19 |
| 8. Oil Pan, Oil Filter, and Oil Pump and Pressure Relief Valve | 23 |
| 9. Cylinder Block, Pistons, Piston Rings, and Connecting Rods | 24 |
| 10. Exhaust System | 27 |

Trouble shooting, tune-up, inspection, and repair procedures, applicable to all engines, are given in this chapter. For the removal and installation of engine components, refer to the chapter covering the specific engine.

Inasmuch as a determination of the basic cause of engine trouble should precede any repair work, the trouble

shooting section is presented first. Many defects in engine performance can be attributed directly to a maladjustment of one part, or a combination of parts; therefore, general engine tune-up logically follows the trouble shooting section, and precedes the actual repair work.

1. TROUBLE SHOOTING

Trouble shooting is the application of a definite procedure, in a logical sequence, to locate and eliminate the cause of trouble in a particular system or unit. It should be borne in mind, when trouble shooting, to first look for the obvious causes of trouble such as: an empty gas tank, a wet or cold engine, loose or disconnected wiring, or any other such item that may cause a temporary defect.

The various factors affecting power plant operation are outlined in this section.

a. Engine.

Poor engine performance can be attributed to the engine or to forces on the vehicle that tend to retard its motion. An example of a retarding force is dragging brakes which cause the engine to work harder and results in poor engine performance.

Engine performance depends on proper fuel distribution, correctly timed ignition, normal and uniform compression, properly regulated flow of the fuel-air mixture to the cylinders, and unobstructed flow of exhaust gases.

Engine trouble symptoms are discussed under the headings below with instructions on what to do to correct the above conditions and regain good engine performance.

(1) **ENGINE WILL NOT CRANK.** If the starter does not operate or turns it over too slowly to

start, the fault is likely to be in the battery or the starter. Perform the following checks in the order listed, until the cause of the trouble is determined:

(a) **CHECK THE BATTERY.** Try the horn or lights. If they do not operate properly, test the battery. Recharge it, replace it, or check further, as necessary.

(b) **CHECK THE BATTERY CABLES.** Check for loose or corroded connections at the starter, relay, battery, and ground. Clean, tighten, or replace them as necessary.

(c) **CHECK THE RELAY CIRCUIT.** The relay contact surfaces seldom become so badly burned that they will prevent the starter from cranking the engine. However, other wiring may be at fault. Repair as necessary. (Refer to Electrical System Section.)

(d) **CHECK THE STARTER OR STARTER DRIVE.** If the above components are not at fault, the trouble is probably in the starter or starter drive. If the starter is running, but not engaging the flywheel, remove the starter and make the necessary repairs to the starter drive. In rare cases, the starter drive may lock up with the flywheel. This can be corrected by loosening the starter and releasing the starter drive. If the starter does not operate, remove it and make the necessary repairs.

(2) **ENGINE CRANKS, BUT WILL NOT START.** The most probable cause of this trouble is a defect in the



ignition system. The next most likely cause is a malfunction of the fuel system. A simple check will determine which system is at fault. Remove one wire from a spark plug, and insert a piece of proper sized metal rod so it will protrude from the insulator. With the ignition on and the starter turning the engine over, hold the end of the rod approximately $\frac{3}{16}$ -inch from the block. If no spark is obtained, check the ignition system. If a good spark is obtained, check the fuel system.

(a) **NO SPARK.** If no spark was obtained, follow the steps below to determine the cause and make necessary repairs or replacements.

(1) Pull the coil wire from the top of the distributor, and with the ignition on and the engine turning over, see if there is a spark at this point. If there is a good spark, the trouble lies in the distributor cap, rotor, or spark plug wires. See that they are clean, dry, and not defective. Repair or replace as necessary.

(2) If there was no spark in (1) clean the coil tower socket or replace the high tension wire between the coil and distributor and check again. If a weak spark exists, the points are probably arcing. Test the condenser, replace if necessary and adjust the points. If a weak spark persists, test the coil and replace if necessary.

(3) If there was no spark in (2), remove the distributor cap and see if the points are "breaking" and there is an electrical charge to the points. Adjust or replace as necessary. If there is spark at the points, and they break properly, the secondary circuit of the coil is defective. If there is no spark at the points; install a "jumper" between the distributor post of the coil and the distributor, then check for spark at the points. If there is a spark, replace the coil to distributor primary wire. If there is no spark, install a "jumper" between the two primary coil terminals and recheck. Replace the coil if a spark now exists at the points. If not, install a "jumper" between the battery and the battery post of the coil, then check the spark at the points. If a spark exists, the ignition switch or wiring from the switch to the coil is defective and must be repaired or replaced.

(b) **WEAK SPARK.** If the spark test at the spark plug showed a weak spark, perform the following checks in the order listed:

(1) Battery may be weak. Test, recharge, or replace, the battery.

(2) Remove the distributor cap, and check the condition of the points. Adjust, clean, or replace them as necessary. Severely pitted points are usually an indication that the voltage regulator is improperly set or the condenser is faulty.

Check the condition of the rotor, distributor cap, and spark plug wires. They should be clean, dry, and must be replaced if necessary. Always replace any wire with new wire. Check the terminals.

(4) If the weak spark persists, the coil should be tested and replaced if necessary.

(c) **GOOD SPARK.** If a good spark was observed, check the fuel system as follows:

(1) Check the fuel supply at the fuel tank. Do not attempt any other fuel system checks before doing this.

(2) If there is fuel in the tank, check to see if it is reaching the carburetor. Remove the air cleaner, and look down the carburetor throat while working the throttle by hand. Each time the throttle is worked, a spurt of gasoline should be emitted from the accelerator pump discharge nozzle. If there is fuel at this point, the engine is probably flooded or there is water in the fuel system.

(3) If no accelerator pump discharge is observed in the carburetor throat, loosen the fuel pump to fuel tank line at the fuel pump. Remove the fuel tank filler cap. If fuel runs out freely, the line is clean. If not, blow the line out by air pressure from the fuel pump end.

NOTE: Check the flexible gas line for a collapsed condition.

(4) If the fault has not been found, check the fuel pump pressure, then repair or replace the fuel pump or carburetor.

(3) **ENGINE STARTS BUT FAILS TO KEEP RUNNING.** The most probable cause of this malfunction is the fuel system. The ignition system sometimes can cause trouble, but it is usually after the engine has run for some time and is at operating temperature. In either case, check the fuel system first.

(a) Check the fuel supply at the gas tank.

(b) Try to start the vehicle. If it will operate with constant foot throttle, adjust the idle speed and check the choke adjustment.

(c) If it will not operate with constant foot throttle, remove the air cleaner, and check to see if fuel is getting to the carburetor. This is done by looking down the carburetor while operating the throttle. If gasoline is observed spurting from the accelerator pump discharge nozzle, the engine was either flooded or the fuel system has water in it.

(d) If no accelerator pump discharge is observed in the carburetor throat, loosen the fuel pump to fuel tank line at the fuel pump. Remove the fuel tank filler cap. If fuel runs out freely, the line is clear. If not, blow the line out with air pressure from the fuel pump end.

NOTE: Check the flexible gas line for a collapsed condition.

(e) If the cause of the trouble has not been found, check the fuel pump pressure, and repair or replace the fuel pump or carburetor.

(f) If the fuel system is operating correctly and the engine still stalls, it may be due to the coil or condenser breaking down under operating temperature. Check and replace as necessary.

Check the condition of the rotor, distributor cap, and spark plug wires. They should be clean, dry, and must be replaced if necessary. Always replace any wire with new wire. Check the terminals.

100% SATISFACTION GUARANTEED
BUY IT NOW!
Click Here To Order



(4) ENGINE CONTINUALLY MISSES AT IDLE.

When the engine continually misses on the same cylinders, the fault generally lies in the ignition system.

(a) Isolate the miss by pulling one spark plug cable at a time from the plugs. Remove the plugs, then clean, inspect, and adjust them. Replace those that are badly fouled.

(b) Check the spark plug wires for signs of deterioration and corrosion. Replace as necessary.

(c) Remove the distributor cap and rotor, then clean and inspect them. Replace if necessary.

(d) If none of the above corrects the condition, check the compression to determine if compression and intake manifold passages are satisfactory.

(5) ENGINE MISSES ERRATICALLY AT IDLE.

This may be caused by a combination of things. Check the following in sequence:

(a) Carburetor, including choke operation, idle mixture setting, and float level.

(b) The ignition system, starting with the spark plugs, if the carburetor adjustment does not eliminate the trouble. Make necessary repairs.

(c) The vacuum lines for leaks at all lines and fittings if the miss is still present. Make any necessary repairs.

(d) Valve operation and make a compression test if miss persists.

(6) ENGINE MISFIRES OR HESITATES ON ACCELERATION. This malfunction is usually a combination of faults in the ignition and fuel system, but also can be caused by the exhaust system. Perform the following checks in the sequence given:

(a) Check the operation of the accelerator pump.

(b) Check the operation of the exhaust thermostat valve. If sticking, free up or replace as necessary.

(c) Check the paint on the intake manifold heat riser passage. If the paint is not burned off, the passage may be obstructed and the carburetor may not be vaporizing the gasoline properly.

(d) Remove the spark plugs, inspect, clean and re-gap. Replace any plugs that are defective or lead fouled.

(e) Remove the distributor cap and check the point gap, distributor shaft clearance, condition of cam lobes, and points. Make necessary repairs or replacements. Check the high tension wiring for signs of deterioration, and replace if necessary.

(f) Make a coil and condenser check. Replace faulty units.

(g) Check fuel pump pressure and adjust carburetor float level.

(h) If the problem still persists, take compression readings and check the valve action. Check the valve opening rates and assembled height. Repair or replace as

compression. However, some preliminary checks should be made. Make certain that the throttle opens all the way and that the choke remains open.

(a) After preliminary checks are made, check the compression. This should quickly indicate whether the internal components are operating properly.

(b) If the compression checks within limits, check the ignition system, including initial timing and distributor operation.

(c) If the compression and the ignition system are satisfactory, check the fuel system, including carburetion and fuel pump pressure.

(d) If the problem still exists, a check of mechanical components must be made. Check the valve lash, lift, and timing. Repair or replace as necessary.

b. Fuel System.

The fuel system consists of the fuel tank, fuel pump, carburetor, and connecting lines. Dirt and other foreign material are a major source of fuel system problems, and all components should be kept as clean as possible.

(1) EXCESSIVE FUEL CONSUMPTION. Faulty carburetion is usually responsible for excessive fuel consumption. However, the following preliminary checks should be made. Check for fuel leaks in the system, check choke operation and adjustment, and make certain the accelerator linkage is free. Check to see if the brakes are dragging. Then adjust the carburetor.

(a) Verify the complaint with test equipment installed in the vehicle. Show the customer how improper operation of the vehicle will affect fuel consumption.

(b) If test shows fuel consumption to be excessive, remove the carburetor and rebuild. Since poor carburetion is usually a combination of internal malfunctions, it is usually not advisable to try to repair only one system in the carburetor. Time will be saved by a complete carburetor overhaul.

(2) CARBURETOR FLOODS. Make a visual inspection of the carburetor for leaking gaskets or casting defects. Tap the carburetor bowl. If the flooding stops, the needle was held open by foreign material. If the flooding persists, follow the steps below:

(a) Remove the air cleaner and check choke operation.

(b) Check the float level and the condition of the carburetor float. Check the condition of the needle and seat. Replace if necessary.

(c) Check fuel pump pressure. If the pressure is excessive, the pump was forcing fuel past the float needle and should be rebuilt or replaced.

c. Cooling System.

The cooling system is thermostatically controlled to regulate engine operating temperature and provide for a short engine warm-up period.



is usually caused by poor

(1) **ENGINE OVERHEATS.** Usually, engine overheating is the result of insufficient coolant supply. Check the coolant level first. Make certain that the cause of trouble is not anti-freeze evaporation.

(a) If the supply is low, check for leaks in the cooling system, make repairs as necessary.

(b) Check the water pump belt for proper tension and adjust if loose.

(c) Inspect the radiator fins for obstructions (bugs, dirt, etc.) Clean if clogged.

(d) Using a thermometer in the radiator, check the gauge reading for accuracy.

NOTE: *Inaccurate readings are sometimes caused by insufficient clearance between the head casting and the temperature sending unit element. Repair or replace as necessary.*

(e) Check the thermostat for proper operation and heat range. If defective or of the wrong heat range, replace the thermostat.

(f) Check the ignition timing and adjust if necessary.

(g) Check the radiator for proper flow. Flush if necessary.

(h) Remove the water pump and check for a defective impeller or water passage obstruction. Repair or replace as necessary.

(2) **ENGINE FAILS TO REACH NORMAL OPERATING TEMPERATURE.** Generally, this is caused by the thermostat sticking or being of the wrong heat range. Check the thermostat first. If the engine still does not reach operating temperature, check the gauge and sending unit, with a thermometer in radiator, for accuracy. Replace the defective unit.

2. ENGINE TUNE-UP

During the life of an automotive vehicle, it should receive regular maintenance and inspection services. However, to maintain satisfactory performance, an engine tune-up should be performed periodically.

Any type of engine test equipment may be used to make the tests outlined in the checking procedures. As the checks are performed, make a visual inspection of the wiring, vacuum hose, cooling system hose, heater hoses, etc.

a. Minor Tune-Up.

A minor tune-up consists of the following operations:

(1) **INSPECT IGNITION WIRES, BATTERY CABLES, AND CHECK CONDITION OF THE BATTERY.** Inspect all ignition cables for worn or damaged insulation. Make sure that the spark plug wires are firmly seated in the distributor cap and that the terminals and terminal sockets are free from corrosion.

Inspect the battery case for cracks and leaks. Check the water level in the battery. Inspect battery cable connections for corrosion, and clean if necessary. Brush the cable connectors with grease to retard further corrosion, then tighten the connectors securely.

(2) **TEST CYLINDER COMPRESSION.** Operate the engine until normal operating temperature is reached. Turn the ignition switch off. Remove all spark plugs. Set the throttle to wide open position and leave it open for the test. Using a compression tester, test the compression of each cylinder. Crank the engine for at least four compression strokes. All cylinders should be tested the same number of strokes to assure accurate readings.

Compression of all cylinders should be uniform. Compression of each cyl-

A reading of more than 10 pounds above normal indicates carbon or lead deposits in the cylinder.

A reading below normal indicates leakage at the rings, valves, or head gasket.

(3) **CLEAN, ADJUST, AND INSTALL SPARK PLUGS.** Sandblast the spark plugs, wipe the porcelain clean, file the electrode tips flat, and adjust the spark gap. Test the plugs in an approved spark plug tester. Replace any plugs that have broken or chipped porcelain, badly burned electrodes, or that do not check satisfactorily on the tester. Install the spark plugs and tighten to specifications.

(4) **CHECK AND ADJUST TIMING AND INSPECT BREAKER POINTS.** Disconnect the vacuum line between the distributor and carburetor. Start the engine and operate it at idle speed. Check the timing with a timing light and make the necessary adjustments. Connect the distributor vacuum line after completing the adjustments. Inspect the distributor points for pits, excessive metal transfer, and burns. Replace points which cannot be cleaned up by light application of a point file.

(5) **CHECK ENGINE VACUUM AND ADJUST CARBURETOR IDLE.** Check the engine manifold vacuum at idle speed.

If the vacuum is lower than specified, check for leakage at the vacuum lines and intake manifold. Check the carburetor idle adjustment.

If the vacuum is still below normal or is erratic, it is an indication of bad rings, sticky valves, weak valve springs, or leaky gaskets. If this condition exists, it should be reported to the customer.

Set the carburetor idle speed to specifications. Set the idle fuel adjustment to obtain the smoothest engine idle at the highest manifold vacuum and/or engine r.p.m. Reset the idle speed if required.



(6) **CLEAN AIR CLEANER AND FUEL PUMP BOWL.** Clean the air cleaner, and re-oil the element (dry-type). If the air cleaner is the oil bath-type, refill to the indicated level with engine oil of the specified viscosity.

Remove and clean the fuel pump bowl. Install a new filter. Install the sediment bowl and a new gasket.

b. Major Tune-Up.

A major tune-up consists of checking the cylinder compression, the ignition system, the fuel system, the engine vacuum, and adjusting the valves.

(1) **CLEAN AND INSPECT BATTERY CABLES.** Remove the cables from the battery. Clean the battery terminals and cable connectors. Inspect the battery case for cracks and leaks. Fill to the proper water level. Replace deteriorated connectors, and cables that are shorted or have worn insulation. Brush the cable connectors with grease to retard corrosion. Connect the cables to the battery.

(2) **TEST CHARGING SYSTEM.** Test the battery, and recharge or replace it, if necessary, to insure dependable service. Check the charging circuit, the generator output, and the regulator. Repair or replace a faulty generator. Adjust or replace the regulator if necessary.

(3) **TEST CYLINDER COMPRESSION.** Follow the procedure given under, "a. Minor Tune-Up."

(4) **CHECK MANIFOLD BOLT TORQUE.** Tighten the intake and exhaust manifold bolts and nuts to 23-28 foot-pounds torque.

(5) **CLEAN, ADJUST, AND INSTALL SPARK PLUGS.** Sandblast the spark plugs, wipe the porcelain clean, file the electrode tips flat, and adjust the spark gap. Test the plugs in an approved spark plug tester. Replace any plugs that have broken or chipped porcelain, badly burned electrodes, or that do not check satisfactorily on the tester. Install the spark plugs, and tighten them to the specified torque.

(6) **TEST DISTRIBUTOR.** Test the distributor vacuum advance on a suitable distributor test stand, and make adjustments, repairs, or replacements as required. Set the distributor point gap at 0.014-0.016 inch (8-cylinder engine) or 0.024-0.026 inch (6-cylinder engine). After setting the gap, check the point dwell. The point dwell should be 35-38 degrees (6-cylinder engine), and 26-28½ degrees (8-cylinder engine). If the dwell angle is not correct at the specified point gap, the distributor cam is worn or the point assembly is damaged. Replace the necessary parts. Lubricate the distributor cam lightly with distributor cam lubricant.

(7) **CLEAN AND INSPECT THE DISTRIBUTOR**

cap for cracks or other
sockets should be free from

(8) **TIME IGNITION.** Before connecting the vacuum line between the distributor and carburetor, start the engine and operate it at idle speed. Check the timing with a timing light and make the necessary adjustments. Connect the distributor vacuum line after completing the adjustment, and check for ignition advance.

(9) **CHECK IGNITION PRIMARY CIRCUIT.** Check the primary circuit amperage with a suitable test machine. The amperage draw with the engine stopped should be 5-5.5 amps. With the engine operating at idle speed, the amperage draw should be 2.75-3.0 amps. Visually inspect the wires for faulty insulation and poor connections.

(10) **TEST SPARK INTENSITY.** Determine if the spark from each spark plug wire will jump a ⅜" inch gap.

If the spark is unsatisfactory at all spark plugs, trouble exists in the coil, condenser, rotor or cap, internally in the distributor, or in the external primary circuit.

If the spark is unsatisfactory at some but not all of the spark plug wires, the trouble is in the wire itself, the wire is not seated in the housing socket, or the distributor cap is shorted.

(11) **CHECK AND ADJUST VALVE LASH.** Check and adjust the valve lash after the engine is thoroughly warmed up.

(12) **TEST FUEL PUMP PRESSURE.** Check the fuel pump pressure. The pressure should be within 4.0-5.0 p.s.i. at 900 r.p.m.

(13) **TEST FUEL PUMP VACUUM.** Check the fuel pump vacuum. If the vacuum is below 10.5 inches of mercury, or if the vacuum drops rapidly when the engine is stopped, repair or replace the pump.

(14) **INSPECT AND CLEAN THE FUEL PUMP.** Remove and clean the fuel pump bowl. Install a new filter. Install the sediment bowl and a new gasket.

(15) **CLEAN CARBURETOR.** Clean the carburetor fuel bowl. Set the float level, and check the accelerator pump operation.

(16) **CLEAN AIR CLEANER.** Clean the air cleaner, oil the element (dry-type), and install. If the air cleaner is the oil bath-type, fill to the indicated level with engine oil.

(17) **TEST ENGINE VACUUM.** Check the engine manifold vacuum at idle speed.

If the vacuum is lower than specified, check for leakage at the vacuum lines and intake manifold. Check the carburetor idle adjustment.

If the vacuum is still below normal or is erratic, it is an indication of bad rings, sticky valves, weak valve springs, or leaking gaskets. If this condition exists, it should be reported to the customer.

(18) **ADJUST CARBURETOR IDLE.** Connect a vacuum gauge, and set the idle speed to specifications with a tachometer installed on the engine. Set the idle



fuel adjustment to obtain the smoothest engine idle at the highest manifold vacuum and/or engine r.p.m. Reset the idle speed if required.

(19) **ROAD TEST.** Road test the vehicle as a final

check on the work performed. Also, notice the performance of the transmission, axle, brakes, and any optional accessories. Recommend any additional service required when the vehicle is delivered to the owner.

3. ENGINE REMOVAL AND INSTALLATION

Separate procedures are given for the conventional passenger car and the Thunderbird.

a. Conventional Passenger Car.

The following procedures apply to all conventional passenger cars. Differences in the procedures peculiar to vehicles equipped with an 8 or 6-cylinder engine are noted when they exist.

The procedures given are for the engine only, without the transmission attached. Engine compartment tolerances make it impractical to remove or install the engine with the transmission attached.

(1) **REMOVAL.** If the vehicle is equipped with a standard or overdrive transmission, follow steps (a) and (c). If the vehicle is equipped with Fordomatic, follow steps (b) and (c).

(a) **STEPS PECULIAR TO STANDARD OR OVERDRIVE TRANSMISSION.** Disconnect the clutch release spring. Remove the screws retaining the equalizer bar support to the flywheel housing, then remove the support and bushing. Disconnect the accelerator linkage at the manifold bellcrank. Remove the two upper flywheel housing bolts. Remove the flywheel housing cover, support the transmission with a jack, then remove the remaining flywheel housing bolts.

(b) **STEPS PECULIAR TO FORDOMATIC.** Disconnect the transmission throttle linkage at the cross shaft, and tie the linkage to the dash panel. Remove the idler arm bracket. Fold back the floor mat, remove the two rubber plugs, then remove the two top converter housing to engine bolts. Jack up the front of the vehicle and position safety stands. Support the transmission with a jack, then remove the remaining converter housing to engine bolts. Remove the converter housing lower access cover, then remove the six converter to flywheel assembly bolts. Remove the dip stick tube assembly.

Remove the transmission control linkage splash shield from the cylinder block, then remove the oil filter.

(c) **ENGINE REMOVAL.** Remove the hood. Drain the cooling system and the crankcase. Remove the heater hoses.

On vehicles equipped with an 8-cylinder engine, remove the heater inlet duct.

On vehicles equipped with a 6-cylinder engine, remove the heater hoses, then remove the battery ground cable

at the cylinder block, and the flex fuel line at the fuel pump. Remove the fan.

Disconnect the windshield wiper vacuum hose, temperature sending unit wire, and the oil pressure sending unit wire. Disconnect the primary wire at the coil. Remove the starter cable at the starter then remove the starter. Disconnect the ground cable from the rear of the engine. Remove the air cleaner, then tape the air horn closed. Disconnect the choke cable at the carburetor. Disconnect the accelerator linkage.

Disconnect the muffler inlet pipes at the exhaust manifold.

Attach the engine lift bracket or sling (fig. 1 or 2). Remove the right and left front splash aprons.

Loosen the two engine front steady rest to frame bolts. Raise the vehicle and position safety stands.

On 8-cylinder engines, remove the left-hand engine support. Remove the cap screws from the right-hand engine support at the engine.

On 6-cylinder engines, remove the left-hand mounting bolts at the insulator, and the right-hand mounting nuts at the engine.

Raise the engine slightly, then carefully pull the engine from the transmission. Carefully lift the engine out of the engine compartment. Do not let the engine swing against the grille.

Install the engine on a work stand using the appropriate engine mount (fig. 3 or 4). Remove the engine lifting bracket or sling.

(2) **INSTALLATION.** If the vehicle is equipped with a standard or overdrive transmission, follow steps (a), (b), and (d). If the vehicle is equipped with Fordomatic, follow steps (a), (c), and (d).

(a) **ENGINE INSTALLATION.** Install the appropriate engine lift bracket or sling, then remove the engine from the work stand. Lower the engine carefully into the engine compartment.

On 8-cylinder engines, lower the engine until the oil pump to oil pan line clears the left-hand engine support.

Start the transmission main drive gear into the clutch disc. On Fordomatic units, start the converter pilot into the crankshaft.

NOTE: *On standard or overdrive units, it may be necessary to adjust the position of the transmission with relation to the engine if the transmission input shaft will not enter the clutch disc. If the engine "hangs up" after the shaft enters, turn the crank-*

100% SATISFACTION GUARANTEED

BUY IT NOW!

Click Here To Order

PayPal American Express Discover MasterCard VISA

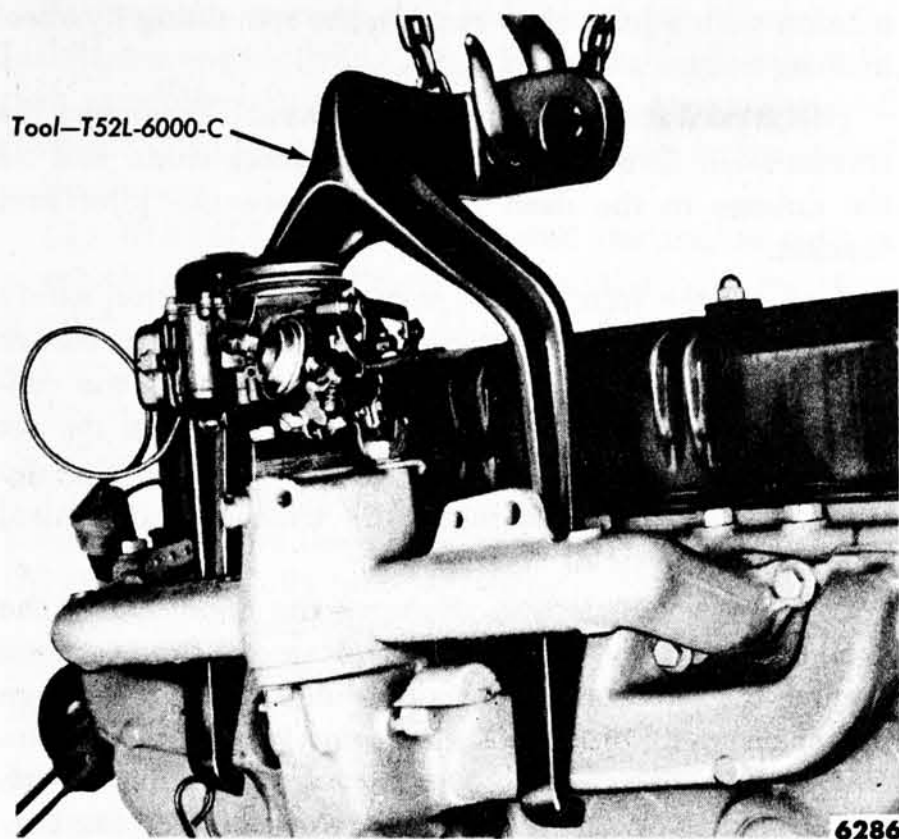
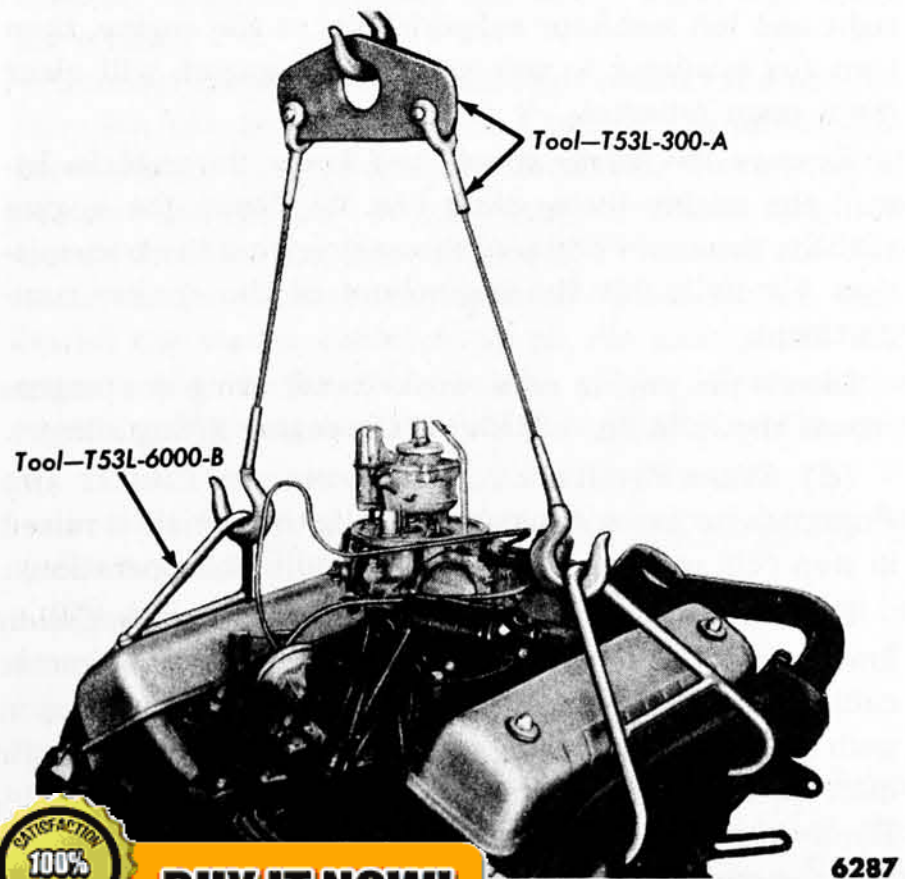

Fig. 1—Lift Bracket—6-Cylinder Engine

shaft slowly (with the transmission in gear) until the shaft splines mesh with the clutch disc splines.

Make sure the studs on the manifolds of both the 6 and 8-cylinder engines are aligned with the holes in the muffler inlet pipes, and the dowels in the block engage the holes in the clutch housing (on Fordomatic units the block dowels must engage the holes on the converter housing).

On the 6-cylinder engine, install the right-hand mounting nuts. Install the left-hand mounting bolts. Tighten all



8-Cylinder Engine

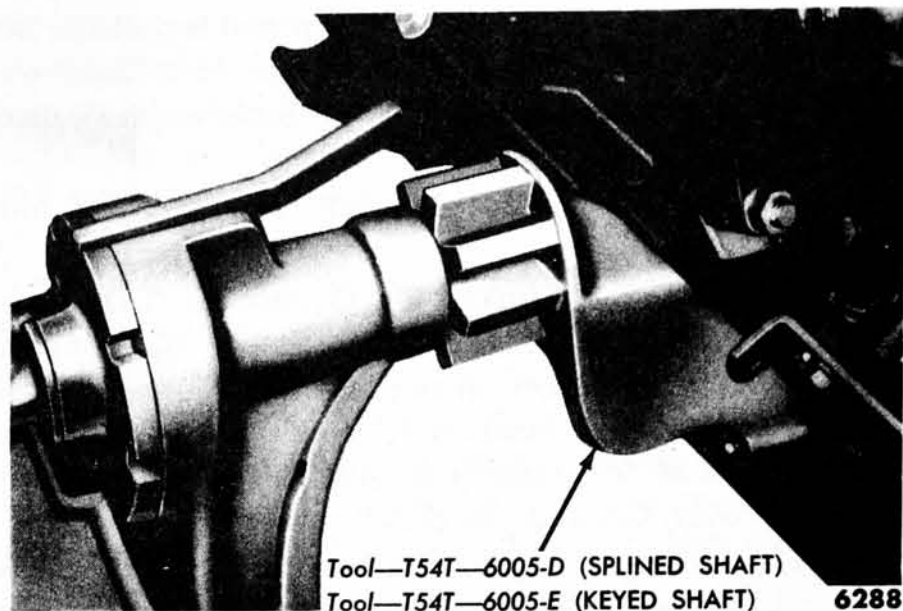

Fig. 3—Engine Mount—8-Cylinder Engine

mounting nuts and bolts to specifications. Tighten the two engine front steady rest to frame bolts to specifications.

On the 8-cylinder engine, align the holes in the engine left support insulator with the mounting holes in the block. Install the two cap screws on the right side of the engine. Tighten the two engine front steady rest to frame bolts to specifications. Install the right and left front splash aprons.

Connect the manifold to the muffler inlet pipe. Install the starter, then connect the starter cable (except Fordomatic). Connect the ground cable to the rear of the engine, the temperature sending unit and oil pressure sending unit wires, the generator wires, and the ignition switch wire to the coil. Connect the ignition switch wire to the engine clips. Connect the accelerator linkage and the choke wire.

Connect the windshield wiper line and the fuel pump vacuum line. Connect the fuel pump flexible line. Install the fan assembly, then adjust the fan belt.

Install the radiator and connect the radiator hoses. Connect the battery ground cable to the engine. Remove

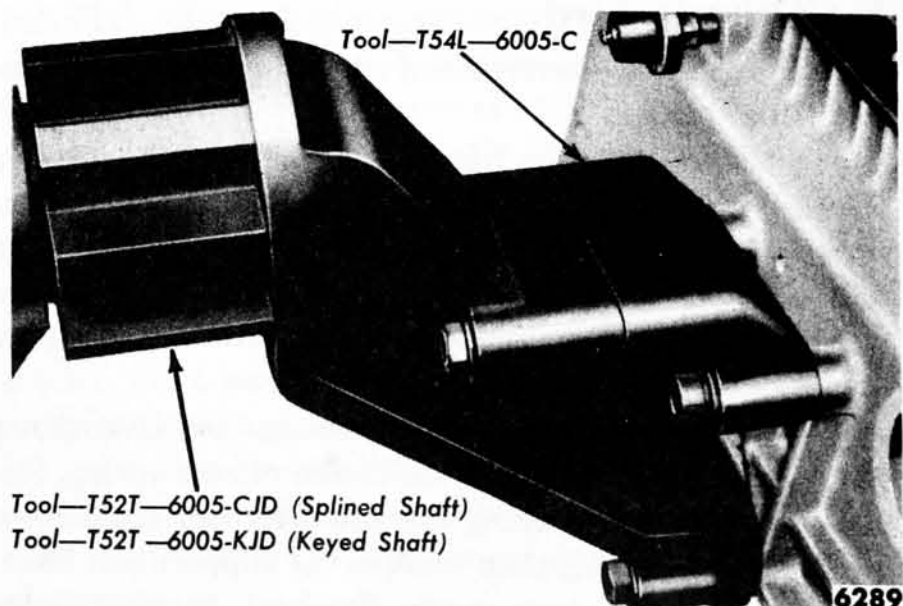

Fig. 4—Engine Mount Adapter—6-Cylinder Engine

100% SATISFACTION GUARANTEED

BUY IT NOW!

Click Here To Order

PayPal American Express Discover MasterCard VISA

the tape from the carburetor air horn and install the air cleaner. Install the heater blower motor (6-cylinder engine) and the heater inlet duct (8-cylinder engine), then connect the heater hoses.

Install the hood. Fill the cooling system and the crankcase.

(b) **CONNECT STANDARD OR OVERDRIVE TRANSMISSION.** Install the bushings in the equalizer bar support, then install the support on the flywheel housing. Install the transmission to flywheel housing bolts, and tighten them to 40-50 foot-pounds torque. Install the flywheel housing cover. Connect the clutch release spring.

Remove the jack supporting the transmission. Check the clutch pedal free play ($1\frac{1}{8}$ - $1\frac{3}{8}$ inch). Adjust the free play if necessary.

(c) **CONNECT FORDOMATIC TRANSMISSION.** Install the two converter housing to engine lower bolts, and tighten them to 40-45 foot-pounds torque.

NOTE: *Tighten the bolts slowly and evenly to avoid binding on the dowel pins.*

Install the two converter housing to engine upper engine bolts, and tighten them to 40-45 foot-pounds torque. Install the floor pan plugs, and position the floor mats. Align the flywheel and drive plate holes with the converter, install the six bolts, and tighten them to 25-28 foot-pounds torque.

Install the starter, and tighten the bolts to 15-20 foot-pounds torque. Install the dipstick tube assembly. Install the idler arm and bracket. Tighten the idler arm bracket nuts to 28-43 foot-pounds torque. Install the converter housing lower access covers.

Install and connect the throttle linkage and make the necessary linkage adjustments. Remove the jack supporting the transmission.

(d) **CHECK ENGINE FOR OIL OR COOLANT LEAKS.** Warm the engine to normal operating temperature, then check all gaskets and hose connections for leaks.

b. Thunderbird.

The engine may be removed with or without the transmission attached.

(1) **REMOVAL.** To remove the engine only, from a vehicle equipped with a standard or overdrive transmission, follow steps (a) and (c). To remove the engine only, from a vehicle equipped with Fordomatic, follow steps (b) and (c). To remove the engine and Fordomatic as an assembly, follow steps (c) and (d).

(a) **STEPS PECULIAR TO STANDARD OR OVERDRIVE TRANSMISSION.** Disconnect the clutch release spring. Remove the screws retaining the equalizer bar support to flywheel housing, then remove the support and bushings. Remove the flywheel housing bolts. Remove the flywheel housing cover, support the trans-

mission with a jack, then remove the remaining flywheel housing bolts.

(b) **STEPS PECULIAR TO FORDOMATIC.** Disconnect the transmission throttle linkage at the cross shaft, and tie the linkage to the dash panel. Remove the idler arm bracket.

Jack up the front of the vehicle, and position safety stands. Support the transmission with a jack, then remove the converter housing to engine bolts. Remove the converter housing lower access cover, then remove the six converter to flywheel assembly bolts. Remove the dip stick tube assembly. Remove the transmission control linkage splash shield.

(c) **ENGINE REMOVAL.** Remove the hood. Drain the cooling system and the crankcase. Remove the fan, then remove the radiator and shroud as an assembly. Remove the air cleaner. Disconnect the engine ground wire at the dash panel. Disconnect the battery ground cable at the engine and the battery to starter relay cable at the battery. Disconnect the vacuum pump line, and the fuel inlet line at the fuel pump. Disconnect the starter cable at the starter solenoid, then remove the cable clamp at the dash panel. Disconnect the ignition switch to coil wire at the coil. Disconnect the two heater hoses. Remove the generator wires. Remove the wires from the oil pressure sending unit and the temperature sending unit. Remove the heater blower assembly. Disconnect the tachometer cable. Disconnect the accelerator rod, then disconnect the link bracket at the block (this bracket also serves as the ignition cable bracket).

Raise the vehicle and position safety stands. Disconnect the exhaust pipes at the exhaust manifold. Remove the engine front mount bolt and insulator. Remove the engine right and left insulator support bolts at the engine, then turn the insulator to one side so the engine will clear them upon removal.

Remove the safety stands and lower the vehicle. Install the engine lifting sling (fig. 2). Raise the engine slightly, then carefully pull the engine from the transmission. Carefully lift the engine out of the engine compartment.

Install the engine on a work stand, using the engine mount shown in fig. 3. Remove the engine lifting sling.

(d) **STEPS PECULIAR TO REMOVING THE ENGINE AND FORDOMATIC AS AN ASSEMBLY.** While the vehicle is raised in step (c), perform the following additional operations:

Disconnect the shift control linkage at the transmission and the throttle control rod. Disconnect the speedometer cable. Remove the drive shaft, and plug the transmission with an extension housing cap. Remove the converter air duct assembly. Remove the dip stick tube assembly. Remove engine rear mount bolt, raise the transmission, and remove the cross member that serves as the engine rear mount.



Remove the transmission jack and lower the vehicle. Install the engine lifting sling. Raise the engine slightly, then carefully pull the engine and transmission forward. Carefully lift the engine and transmission from the engine compartment.

(2) **INSTALLATION.** To install the engine only in a vehicle equipped with a standard or overdrive transmission, follow steps (a), (b), and (e). To install the engine only in a Fordomatic equipped vehicle, follow steps (a), (c), and (e). To install the engine and Fordomatic as an assembly, follow steps (a), (d), and (e).

(a) **ENGINE INSTALLATION.** Install the engine lifting sling, then remove the engine from the work stand. Lower the engine carefully into the engine compartment.

Start the transmission main drive gear into the clutch disc. On Fordomatic units, start the converter pilot into the crankshaft.

NOTE: *On standard or overdrive units, it may be necessary to adjust the position of the transmission with relation to the engine, if the input shaft will not enter the clutch disc. If the engine "hangs up" after the shaft enters, turn the crankshaft slowly (with the transmission in gear) until the shaft splines mesh with the clutch disc splines.*

Make sure the studs on the manifold are aligned with the holes in the muffler inlet pipe, and the dowels in the block engage the holes in the clutch housing (on Fordomatic units the block dowels must engage the holes on the converter housing).

Raise the vehicle and position safety stands. Install the engine front insulator and bolt. Install the right and left insulator support bolts. Connect the exhaust pipe to the exhaust manifold. Remove the safety stand and lower the vehicle.

Connect the accelerator rod, then connect the accelerator link bracket to the block. Connect the tachometer cable. Install the heater blower assembly. Install the oil pressure sending unit and the temperature sending unit wires. Connect the generator wires. Connect the two heater hoses. Connect the ignition switch to coil wire. Install the starter cable clamp on the dash panel, and connect the starter cable to the starter. Connect the vacuum pump line and the fuel pump inlet line. Connect

the battery ground cable to the engine and the starter solenoid cable. Connect the engine ground wire. Install the air cleaner. Install the radiator and shroud, then install the fan. Install the hood. Fill the cooling system. Fill the crankcase with the correct quantity and grade of engine oil.

(b) **CONNECT STANDARD OR OVERDRIVE TRANSMISSION.** Install the bushings in the equalizer bar support, then install the support on the flywheel housing. Install the transmission to flywheel housing bolts, and tighten them to 40-50 foot-pounds torque. Install the flywheel housing cover. Connect the clutch release spring.

Remove the jack supporting the transmission. Check the clutch pedal free play (1 $\frac{1}{8}$ -1 $\frac{3}{8}$ inches). Adjust the free play, if necessary.

(c) **CONNECT FORDOMATIC TRANSMISSION.** Install the two lower converter housing to engine bolts, and tighten them to 40-45 foot-pounds torque.

NOTE: *Tighten the bolts slowly and evenly to avoid binding on the dowel pins.*

Install the converter housing to engine bolts, and tighten them to 40-45 foot-pounds torque. Align the flywheel and drive plate holes with the converter, install the six bolts, and tighten them to 25-28 foot-pounds torque.

Install the starter, and tighten the bolts to 15-20 foot-pounds torque. Install the dipstick tube assembly. Install the idler arm and bracket. Tighten the idler arm bracket nuts to 28-43 foot-pounds torque. Install the converter housing lower access covers.

Install and connect the throttle linkage, and make the necessary linkage adjustments. Remove the jack supporting the transmission.

(d) **INSTALL ENGINE AND FORDOMATIC AS AN ASSEMBLY.** While the vehicle is raised in step (a), perform the following additional operations:

Jack up the transmission. Install the engine rear mount. Lower the transmission, then install the engine rear mount bolt. Install the converter air duct assembly. Install the dip stick tube assembly. Remove the extension housing cap from the transmission, and install the drive shaft. Connect the speedometer cable. Connect the shift control linkage and the throttle control rod.

4. INTAKE AND EXHAUST MANIFOLDS

The following inspection procedures are applicable to new and used manifolds.

a. Cleaning and Inspection.

Remove the manifolds. Wash grease, oil, and dirt from the manifolds. Clean the inside of the manifolds with a brush attached to a flexible hose. Clean the air filter. Clean the air filter housing. Clean the air filter. Clean the air filter housing. Clean the air filter. Clean the air filter housing.

Inspect the mating flanges of the intake manifold for cracks, nicks, burrs, or scratches.

On the intake manifold, check the fuel-air passages and the heat riser for restrictions. Check the manifold openings for proper alignment with their respective cylinder head ports. Improper alignment may result in a loss of power.

Inspect the entire intake manifold for cracks or visible



casting defects which would make the manifold unfit for further service.

Inspect the exhaust manifold for burned out spots, cracks, deep nicks, and scratches.

b. Repairs.

Dress nicked or warped mating surfaces on a surface plate. Minor nicks, burrs, or scratches may be removed with a file.

5. ROCKER MECHANISM, CYLINDER HEAD, VALVES, VALVE LASH ADJUSTMENT, AND VALVE TIMING

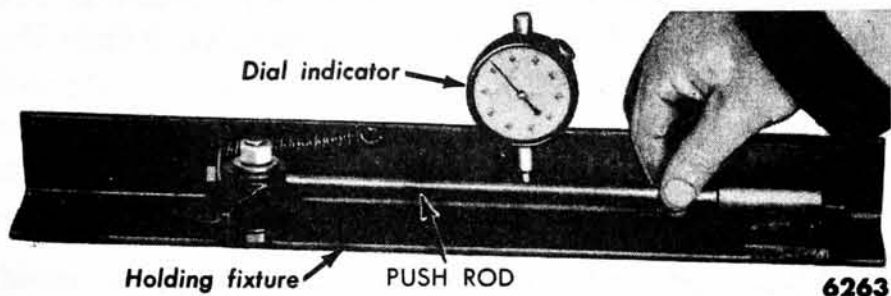

Fig. 5—Push Rod Runout Check

This section covers the inspection and repair procedures applicable to the rocker mechanism, cylinder head, and valves. In addition, the methods used to check valve timing are given.

a. Rocker Mechanism.

Remove and disassemble the rocker mechanism.

(1) **CLEANING AND INSPECTION.** Check the I. D. of the rocker arm bore and the O. D. of the rocker arm shaft, at the location of the rocker arms, against specifications. Make sure these surfaces are free of scuffs, scores, nicks, or scratches. Inspect the rocker arms for grooved pads. Check the rocker adjusting screws and lock nuts for stripped or broken threads and the ball end of the screw for nicks and scratches. Make sure the adjusting screws turn freely in the rocker arms.

Inspect the locating springs for cracks or other signs of failure.

Inspect the oil drain tube for cracks or sharp bends.



①, ③ CHECK DIAGONALLY
② CHECK ACROSS CENTER

6262

Remove all obstructions from the intake manifold passages. Replace cracked or severely warped manifolds and those manifolds which contain unremovable obstructions. Replace defective exhaust manifolds.

CAUTION: Remove all filings and foreign matter that may have entered the manifold as a result of repair work.

Check the push rods for bend between ball and cup centers with a dial indicator (fig. 5). Check the ball end and socket end of the push rods for nicks, grooves, or roughness.

NOTE: A rough check for bent push rods can be made while they are installed in the engine by rotating them (valve closed) and observing the runout. If any runout is observed, be sure to check the rod between centers as described above.

(2) **REPAIRS.** If the clearance between the shaft and rocker arms exceeds .004 inch, replace the shaft and/or the rocker arms. Replace all rocker arms that have severely scored or scuffed bores and/or grooved pads. Replace all severely scored or scuffed rocker shafts. Dress up minor nicks or scratches. Replace all damaged rocker arm lock nuts, adjusting screws, and springs.

Replace the oil drain tube if it is cracked or has a sharp bend.

If the total runout of a push rod exceeds 0.020 inch, at any point, discard the rod. Do not attempt to straighten push rods.

b. Cylinder Head.

Remove the cylinder head.

(1) **CLEANING AND INSPECTION.** Remove carbon deposits from the combustion chamber and valve heads with a scraper and a wire brush. Be careful not to scratch the gasket surface. Clean the gasket surface with solvent to remove any gasket sealer.

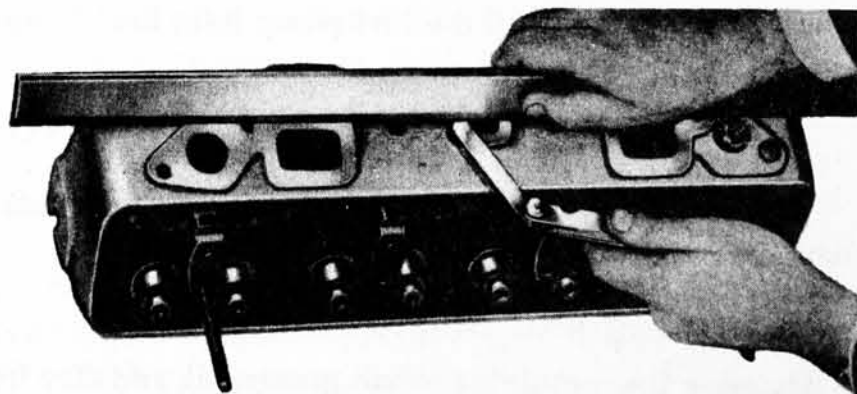

Fig. 7—Checking Flatness of the Intake Port Mating Surfaces

6264



BUY IT NOW!

Click Here To Order

of the Cylinder Head
Face



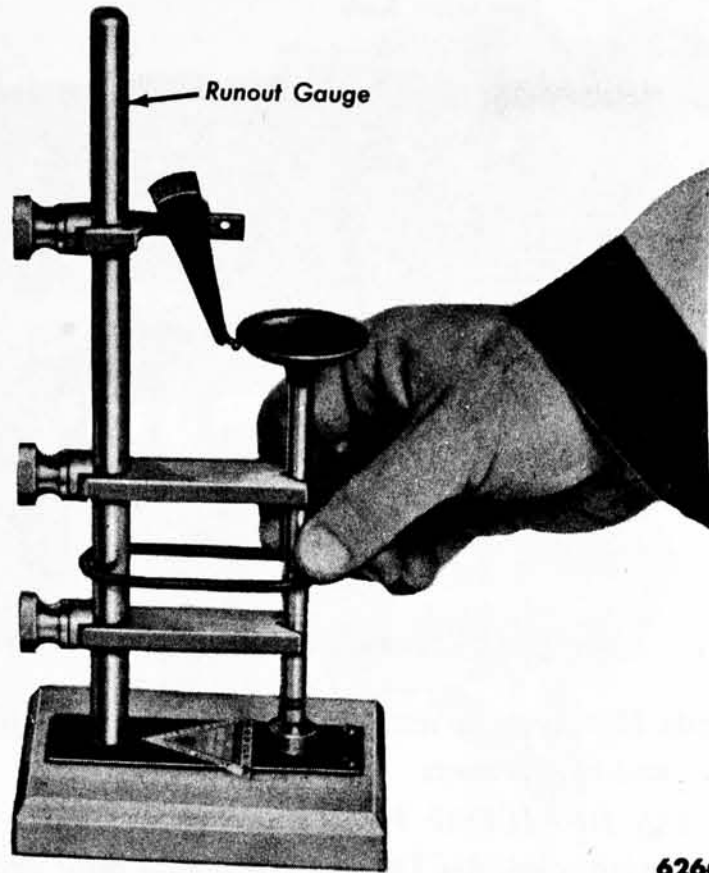

Fig. 8—Valve Face Runout Check

6266

Check the head for cracks. Check the gasket surfaces for flatness (fig. 6). Check to see that all water passages are open. Make sure the gasket surfaces of both head and block are free from burrs or scratches. Check the intake port mating surfaces for flatness as shown in fig. 7.

Check the cylinder head core plug for evidence of leakage.

(2) **REPAIRS.** Remove all burrs or scratches with an oil stone. Replace the head if it is cracked.

If the cylinder head core plug leaks, replace it.



6267

100% GUARANTEED
BUY IT NOW!
 Click Here To Order

Pressure Check

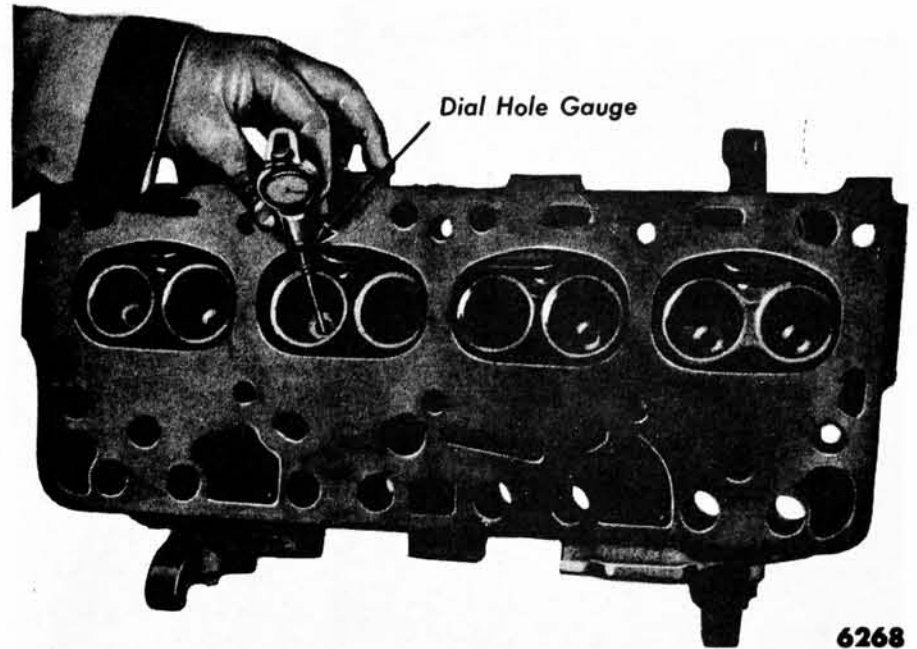

6268

Fig. 10—Measuring I. D. of the Valve Guide

c. Valve Mechanism.

Valve guides are made integral with the cylinder heads. Valves with oversized stems are available as replacements if it becomes necessary to ream the valve guides.

(1) **CLEANING AND INSPECTION.** Disassemble the cylinder head. Discard umbrella-type valve stem seals, and replace with new seals. Scrape and/or wire brush carbon from the head and stem of the valves. Remove varnish from the valve stems. Carefully clean all carbon from the valve seat with a wire brush.

Check the valve for evidence of imperfect seating, heavy discoloration, burning or erosion, or evidence of warpage. Check the valve face runout (fig. 8), and also check the face for pits and grooves. Inspect the ends of the valve stem for grooves or scores.

Inspect the valve springs for cracks or other signs of failure. Check the valve spring pressure (fig. 9), free length, and squareness.

Check the valve spring retainers for wear or signs of failure. Check the tapered seat where the valve locks in the retainer. These locks are split, and wear may be noted by ridges left between the halves of the locks.



6269

Fig. 11—Measuring O. D. of Valve Stem

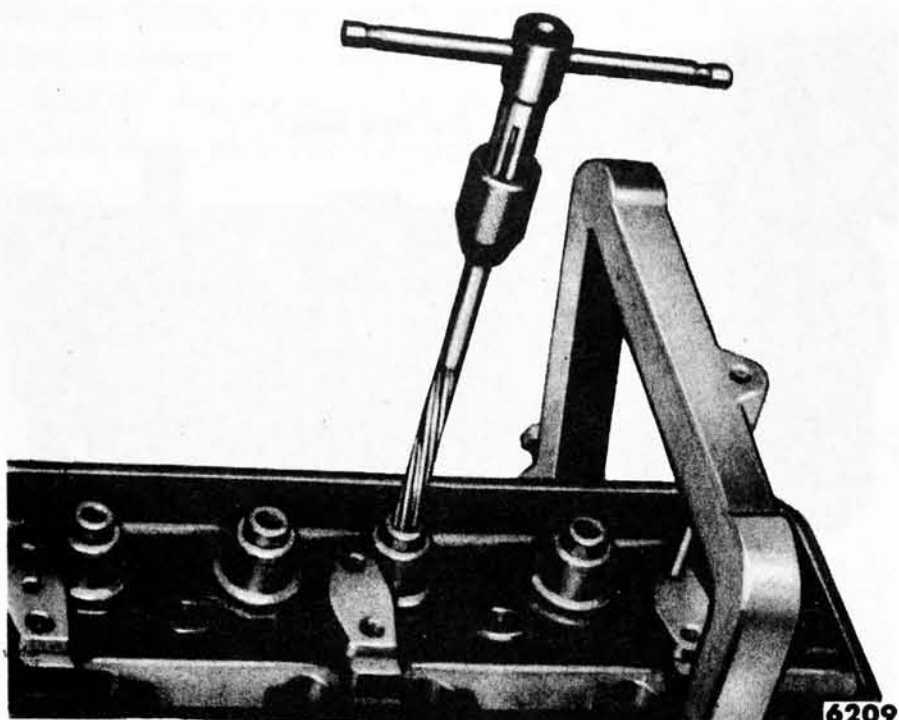

Fig. 12—Reaming Valve Guides

Check the I. D. of the valve guides (fig. 10) and the O. D. of the intake and exhaust valve stems (fig. 11) against specifications. If the clearance is not within limits, and the diameter of the valve stem is on the lower limit, select a new valve with a stem diameter on the upper limit. If the clearance is still not within limits, ream the valve guide (fig. 12) for the next oversize valve stem.

Check the valve seat runout and the valve seat width as shown in figs. 13 and 14.

Discard any defective valves, springs, locks, or retainers.

(2) **REFACING VALVES.** Grind the valve face at a 45° angle on a valve grinder (fig. 15). Grind off only enough stock to remove pits and grooves from the valve face. If the edge of the valve head is less than $\frac{1}{32}$ inch wide after grinding, replace the valve.

If the valve face runout exceeds specifications, grind the valve face. If the runout still exceeds specifications after grinding, discard the valve.

Grind all grooves or score marks from the valve stem

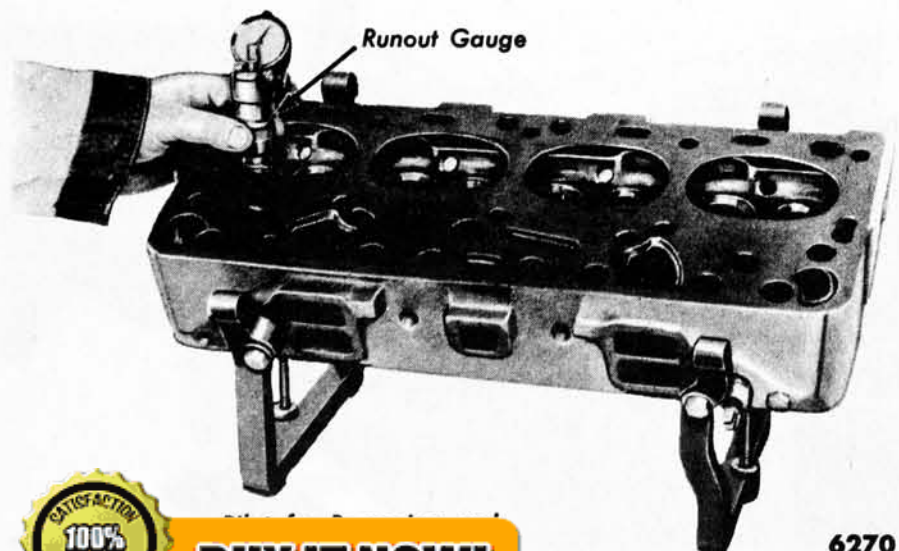

6270

Runout Check

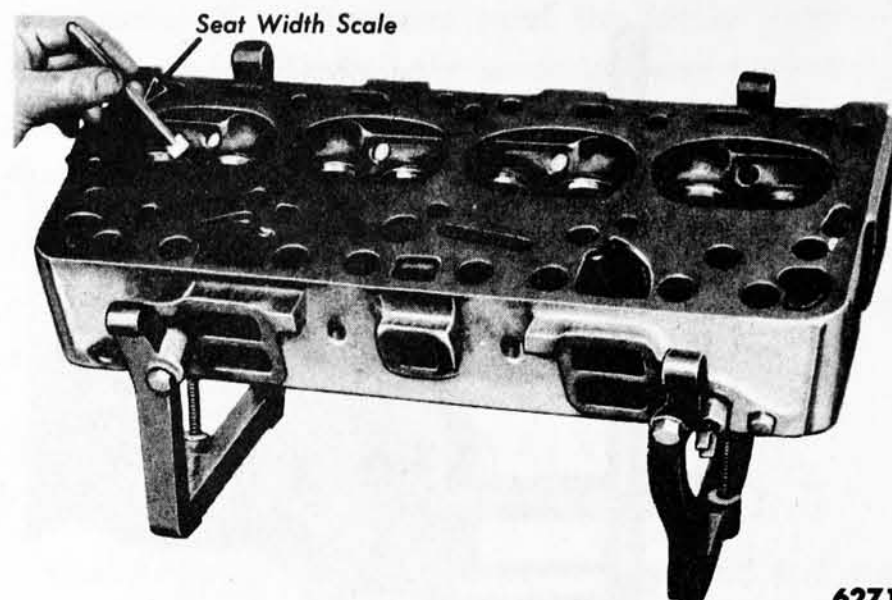

6271

Fig. 14—Measuring Valve Seat Width

ends. However, do not remove more than 0.010 inch from the end of the stem.

(3) **REFACING VALVE SEATS.** Grind the valve seat with a grinder (fig. 16). Remove only enough stock to clean up pits or grooves in the seat. If the valve seat width exceeds specifications (fig. 17), remove just enough stock from the top and bottom edge of the seat to reduce the width. Use a 30° angle wheel to remove stock from the bottom of the seat and a 60° angle wheel to remove stock from the top. Keep the seat as near to the center of the valve face as possible.

After refacing valves and seats, it is good practice to lightly lap in the valves with a medium grade lapping compound to match the seat and the valve. Check the mating of the seat and valve with Prussian Blue or soft lead pencil.

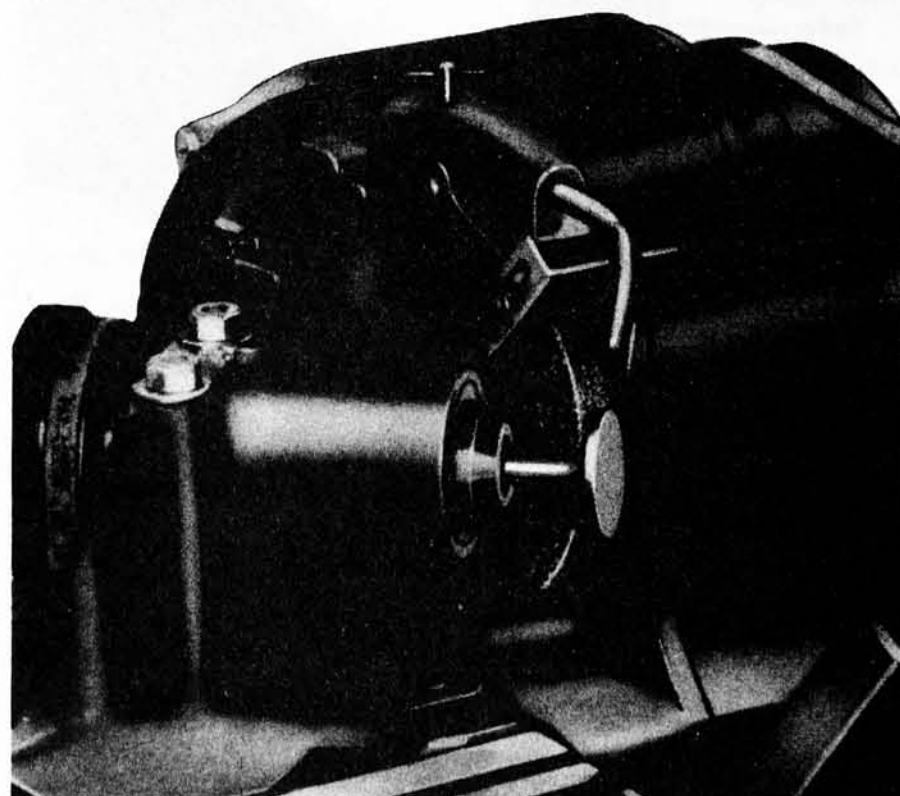

6341

Fig. 15—Refacing Valves

100% SATISFACTION GUARANTEED

BUY IT NOW!

Click Here To Order

PayPal American Express Discover MasterCard VISA

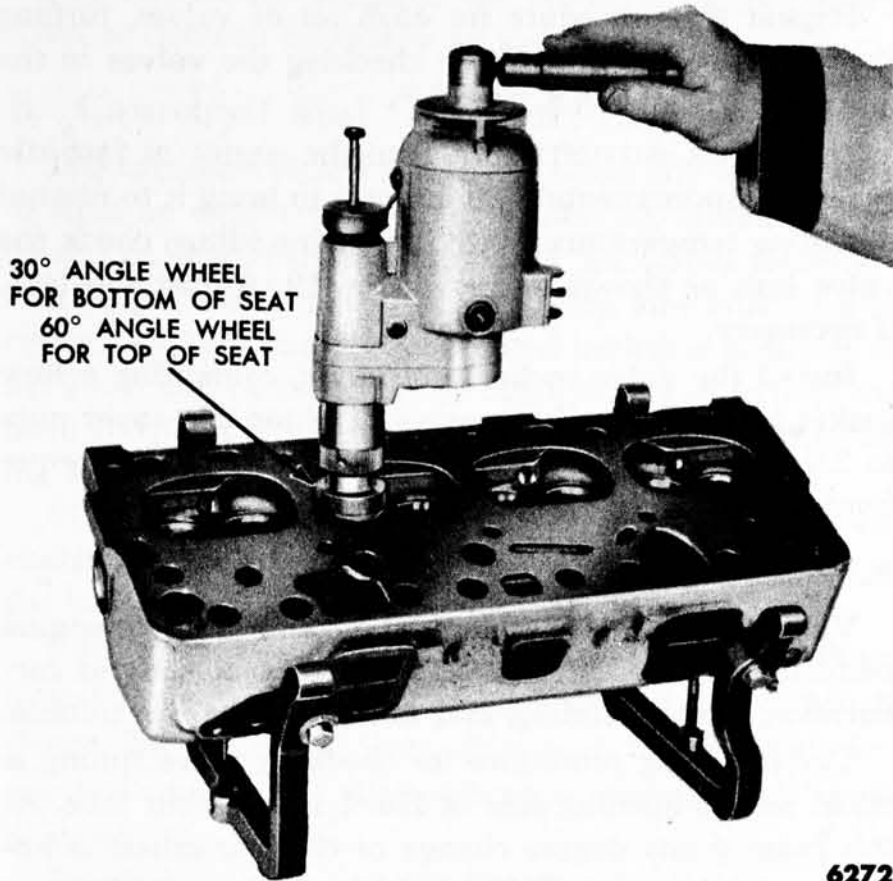

Fig. 16—Refacing Valve Seat

6272

d. Valve Lash Adjustment.

Valve lash is adjusted by means of the set screw and lock nut located on the push rod end of the rocker arm. If the cylinder head or the rocker mechanism has been removed and installed, it will be necessary to make a preliminary adjustment before starting the engine. If the valve lash adjustment is made for the purpose of engine tune-up, omit step (a) and proceed with step (b) under the procedure for the applicable engine.

(1) 6-CYLINDER ENGINE.

(a) PRELIMINARY ADJUSTMENT. Remove the rocker arm cover. Rotate the crankshaft until No. 1 piston is near top dead center (T.D.C.) at the end of the compression stroke.

NOTE: No. 1 piston is near T.D.C. at the end of the compression stroke when both valves are closed and the timing mark on the crankshaft damper is in line with the pointer.

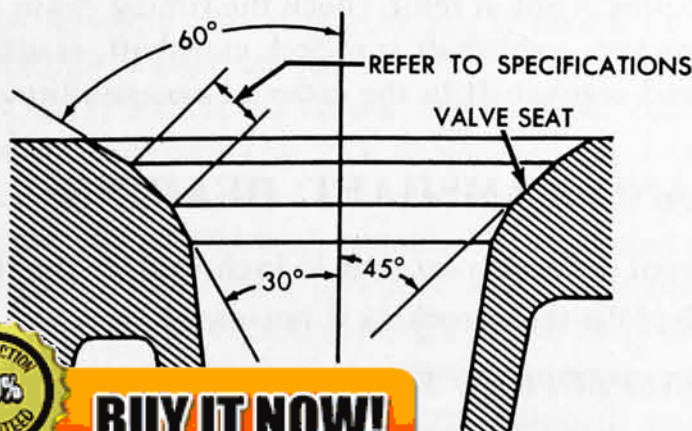

6292

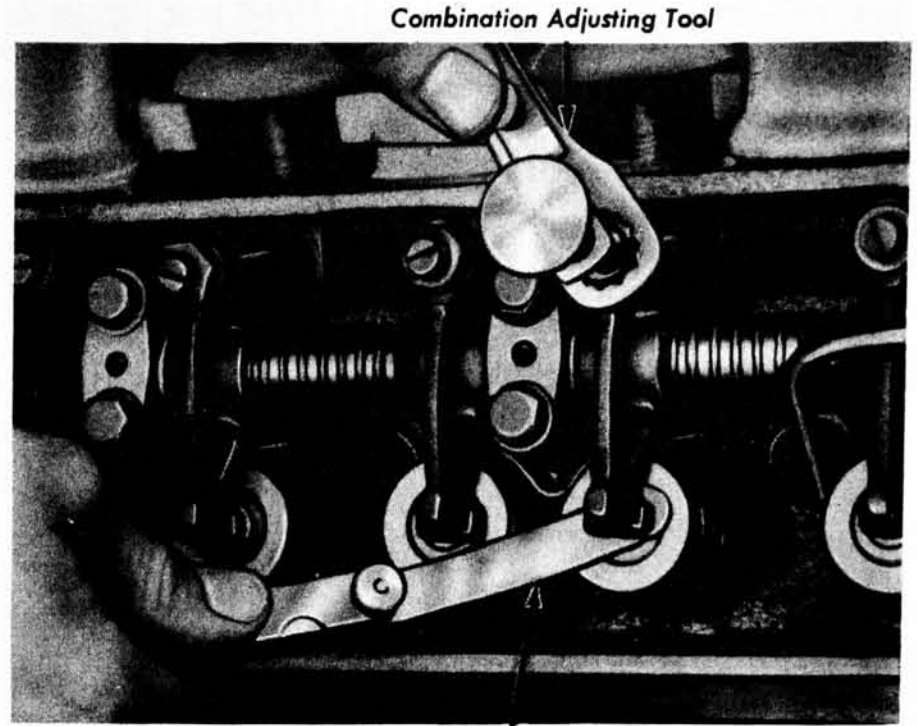

Feeler Gauge

6210

Fig. 18—Valve Lash Check

Check the intake and exhaust valve lash for No. 1 cylinder with a feeler gauge (fig. 18). If the lash is not to specifications, loosen the adjusting screw until this clearance is obtained. Tighten the lock nut without moving the adjusting screw.

Make two chalk marks on the crankshaft damper 120° away from the timing mark (120° represents 1/3 turn of the crankshaft or 1/3 of the way around the damper circumference).

Turn the crankshaft 1/3 turn in the direction of rotation, and check the valve lash of No. 5 cylinder. Repeat this operation for No. 3, No. 6, No. 2, and No. 4 cylinders.

(b) FINAL ADJUSTMENT. Run the engine at fast idle speed for approximately 30 minutes to bring it to normal operating temperature. Check the valve lash for conformance to specifications (fig. 19) with the engine idling.

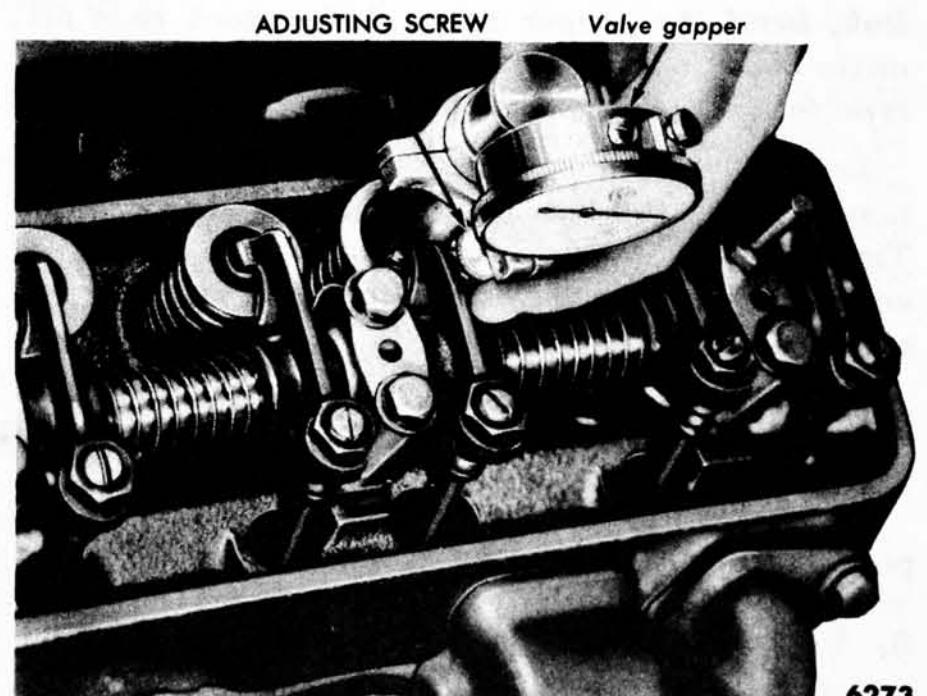

6273

Fig. 19—Valve Lash Check

100% SATISFACTION GUARANTEED

BUY IT NOW!

Click Here To Order

PayPal, American Express, Discover, MasterCard, VISA

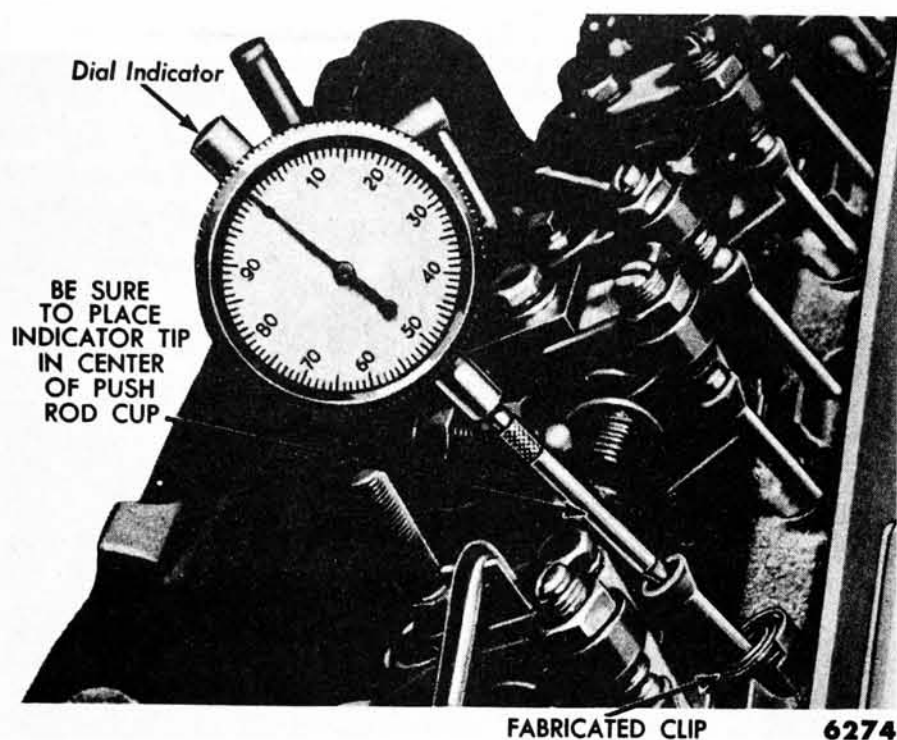

Fig. 20—Camshaft Lobe Lift Check

Adjust the lash, if necessary. Install the valve rocker arm cover, cementing a new gasket to the cover if necessary. Do not tighten the cover nuts to more than 2.0-2.5 foot-pounds torque, or the cover will be distorted.

(2) 8-CYLINDER ENGINES.

(a) **PRELIMINARY ADJUSTMENT.** Remove the rocker arm cover. Rotate the crankshaft until No. 1 piston is near top dead center (T.D.C.) at the end of the compression stroke.

NOTE: No. 1 piston is near T.D.C. at the end of the compression stroke when both valves are closed and the timing mark on the crankshaft pulley or damper is in line with the pointer.

Check the intake valve lash for conformance to specifications (fig. 18).

NOTE: To eliminate the possibility of interference with the exhaust manifolds while adjusting the valve lash, bend the proper gauge feeler stock to a 60° angle about one inch from the end or use an angle type feeler blade holder.

Loosen the lock nut, and adjust the screw to specifications. Tighten the lock nut without moving the screw. Tighten the nut to 30-35 foot-pounds torque. Check and adjust the exhaust valve lash to specifications in the same manner.

6. CAMSHAFT SPROCKET, CAMSHAFT, AND CAMSHAFT BEARINGS

Procedures for the inspection and repair of these components are contained in the following paragraphs.

Timing Chain. removed, measure the out- of the chain (fig. 21). If

Repeat the procedure for each set of valves, turning the crankshaft $\frac{1}{4}$ turn while checking the valves in the firing order (1-5-4-8-6-3-7-2).

(b) **FINAL ADJUSTMENT.** Run the engine at fast idle speed for approximately 30 minutes to bring it to normal operating temperature. With the engine idling, check the valve lash as shown in figs. 18 or 19. Adjust the lash, if necessary.

Install the valve rocker arm cover, cementing a new gasket to the cover if necessary. Tighten the cover nuts to 2.0-2.5 foot-pounds torque. Do not exceed the torque limit or the cover will be distorted.

e. Valve Timing.

Valve timing checks should be made when poor engine performance is noted and all other checks, such as carburetion, ignition timing, etc., fail to correct the trouble.

The following procedure for checking valve timing is taken on the opening side of No. 1 intake cam lobe. At this point a one degree change of the crankshaft is approximately equal to 0.0004 inch change in cam lift.

Remove the rocker chamber cover on the 6-cylinder engine. On 8-cylinder engines, remove the right-hand rocker chamber cover.

Turn the engine over until No. 1 intake tappet is on the heel of No. 1 intake cam lobe.

Back off the No. 1 intake valve adjusting screw, push the rocker arm to one side, then install a dial indicator as shown in fig. 20. Zero the dial indicator, then rotate the engine slowly until the desired lift is obtained (Table 1). Compare the degrees on the pulley with the specifications.

Table 1—Valve Timing Specifications

| Engine | Camshaft | Intake Valve Opens—Crankshaft Degrees at Cam Lift |
|--------|------------|---|
| 223 | EBP-6250-C | 13° BTDC @ .013 Cam Lift |
| 272 | B5A-6250-A | 12° BTDC @ .016 Cam Lift |
| 292 | B5A-6250-A | 12° BTDC @ .016 Cam Lift |

If the valve timing is not within specifications, check for a bent timing pointer as follows: Bring the No. 1 piston to T.D.C. and see if the timing pointer is aligned with the T.D.C. mark on the crankshaft pulley or damper. If the pointer is not at fault, check the timing chain, camshaft sprocket, crankshaft sprocket, camshaft, crankshaft pulley, and crankshaft in the order of accessibility.

the outward deflection exceeds $\frac{1}{2}$ inch, replace the timing chain. Replace the sprockets if necessary.

(1) **INSPECTION.** Remove the camshaft sprocket and timing chain. Inspect the sprocket for worn or damaged teeth. Inspect the chain for broken links.

100% SATISFACTION GUARANTEED

BUY IT NOW!

Click Here To Order

PayPal, American Express, Discover, MasterCard, VISA

(2) **REPAIRS.** Replace the sprocket or the timing chain as deemed necessary by inspection.

b. Camshaft and Camshaft Bearings.

The camshaft must be replaced when any lobe is worn to such an extent that the cam lobe lift (intake or exhaust) is less than the minimum allowable tolerance. The tappet which mates with the worn lobe must also be replaced. Check cam lift with a dial indicator as shown in fig. 20. It will be necessary to fabricate a clip to hold the push rod. The clip shown in fig. 20 is made from banding iron.

(1) **INSPECTION.** Before the camshaft is removed, check the end play for conformance to specifications in the following manner:

Push the camshaft toward the rear of the engine. Place a dial indicator against the rear side of the camshaft flange. Set the dial to zero, then push the camshaft forward. Compare the dial indicator reading with specifications.

Remove the camshaft. Thoroughly check the camshaft for cracks. Examine the lobes for pitting, scoring, and signs of abnormal wear. Check the lobes with a micrometer. Suspected worn lobes should be compared with a good lobe to be sure diagnosis is correct. Measure the journal for wear and out-of-roundness. Measure the camshaft front bearing. The amount of clearance between the bearing surface and the journal should not exceed 0.003 inch. Check the distributor drive gear for broken or worn teeth. Check the fuel pump eccentric for wear.

(2) **REPAIRS.** Replace all camshafts that have cracks or severely scuffed or scored lobes. Remove light scuffs or scores with a hard Arkansas stone, then polish the lobes with crocus cloth. Remove raised metal from small nicks and abrasions elsewhere on the camshaft in the

SLACK SIDE OF CHAIN

DRIVING SIDE OF CHAIN

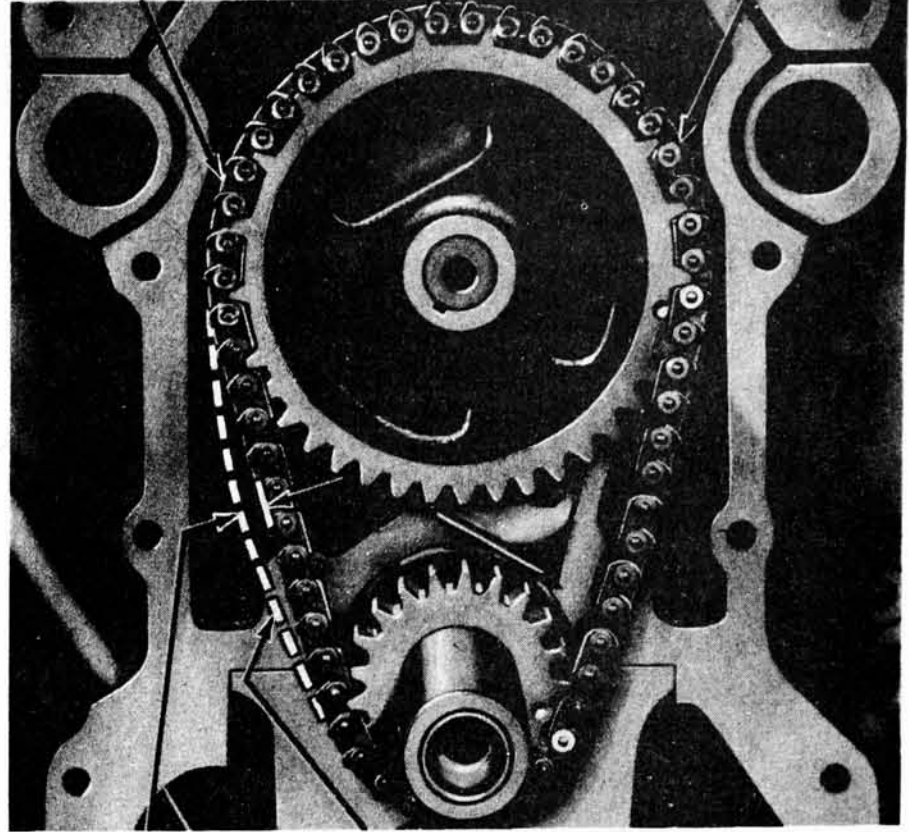

$\frac{1}{2}$ " MAXIMUM LATERAL MOVEMENT OF CHAIN.

FIRST, TAKE UP SLACK ON THIS SIDE OF CHAIN TO ESTABLISH STRAIGHT POSITION OF CHAIN, THEN, TAKE UP SLACK ON DRIVING SIDE OF CHAIN AND MEASURE SLACK SIDE.

6366

Fig. 21—Timing Chain Deflection Check

same manner.

If the front journal to bearing clearance is excessive, it can be assumed that all bearings are worn and need replacement.

If any of the teeth on the distributor drive gear are broken or worn, it will be necessary to replace the camshaft.

If the end play is excessive, replace the thrust plate and/or spacer.

7. FLYWHEEL, CRANKSHAFT, MAIN BEARINGS, AND CONNECTING ROD BEARINGS

Procedures for the inspection and repair of these components are contained in the following paragraphs.

a. Flywheel.

The flywheel and ring gear are a shrink fit and are replaceable as separate parts.

(1) **INSPECTION.** Check the flywheel face runout with a dial indicator (fig. 22). Be sure to hold the flywheel full forward or rearward so that crankshaft end play will not show up as flywheel runout. If the runout exceeds 0.010 inch, remove the flywheel, and check the runout of crankshaft mounting flange. It will be necessary to machine the flange if it is worn, chipped, or cracked. If the runout as indicated in fig. 23.

(2) **REPAIRS.** If the flywheel runout exceeds 0.010 inch and the flange is not at fault, the flywheel should be replaced or machined. Machine the friction surface of the flywheel if it is scored. If it is necessary to remove more than 0.045 inch of stock from the original thickness, the flywheel should be replaced.

If the ring gear teeth are chipped, broken, cracked, or worn, or if the runout exceeds 0.010 inch, replace the ring gear as follows:

Heat the defective ring gear with a blow torch on the engine side of the gear, then knock it off the flywheel.

CAUTION: Do not hit the flywheel when removing the ring gear.

Heat the new ring gear evenly until the gear expands



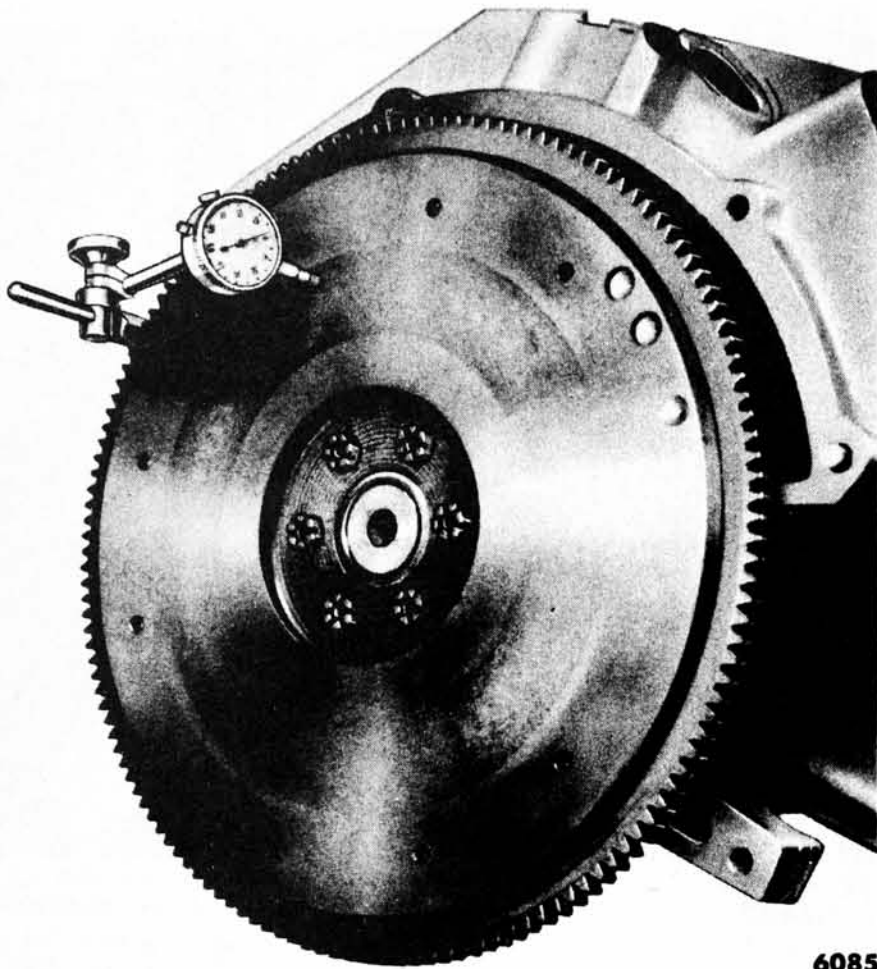

6085

Fig. 22—Flywheel Runout Check

enough to slip onto the flywheel. Make sure the gear is seated properly against the shoulder.

CAUTION: Do not heat any portion of the gear to a temperature higher than 500° F. If this limit is exceeded, the temper will be removed from the ring

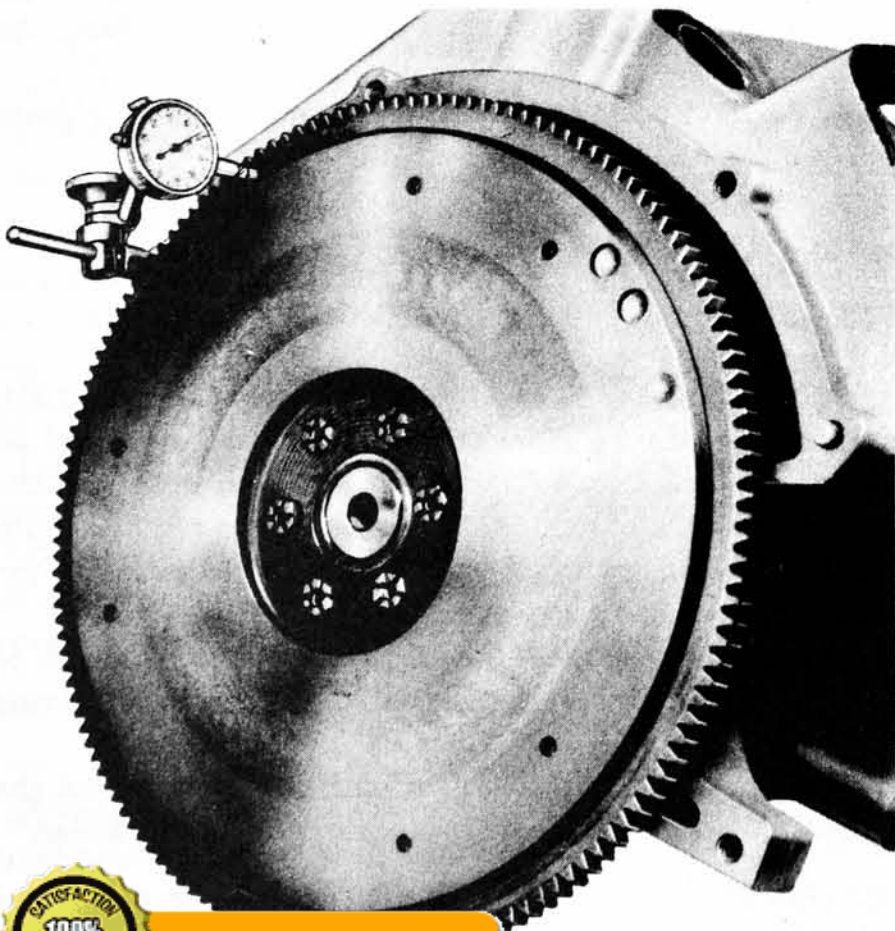

6084

1158

gear teeth. When the new ring gear is installed, perform a runout check on the ring gear and flywheel.

b. Crankshaft.

(1) **CLEANING AND INSPECTION.** Before the crankshaft is removed, the end play should be checked for conformance to specifications in the following manner:

Push the crankshaft toward the rear of the engine. Place a dial indicator against the rear side of the crankshaft flange. Set the dial on zero then push the crankshaft forward. Compare the reading on the dial indicator with specifications.

After removing the crankshaft, wash it in a solvent, and blow out the oil passages with compressed air. Examine the shaft for cracks or other signs of failure.

Measure each crankpin and journal diameter for conformance to specifications. Check the shaft journals for taper and out-of-roundness at several places around the circumference.

(2) **REPAIRS.** If the end play is not within specifications, replace the number three main bearing.

Replace the crankshaft if it shows signs of failure. Dress minor nicks or scratches.

If the pins or journals are out-of-round beyond the specified limits, the shaft should be ground for the next undersize bearing. Calculate the correct undersize bearing to be used as follows:

EXAMPLE: If the main bearing journal will “clean-up” before it is ground to 2.499—0.010=2.489 inches diameter, finish it to that diameter, and install 0.010 inch undersize bearings.

CAUTION: Never grind journals or crankpins in excess of 0.030 inch undersize.

100% SATISFACTION GUARANTEED

BUY IT NOW!

Click Here To Order

Runout Check

PayPal American Express Cards DISCOVER NOVUS MasterCard VISA

Fig. 24—Bearing Failure—Lack of Oil

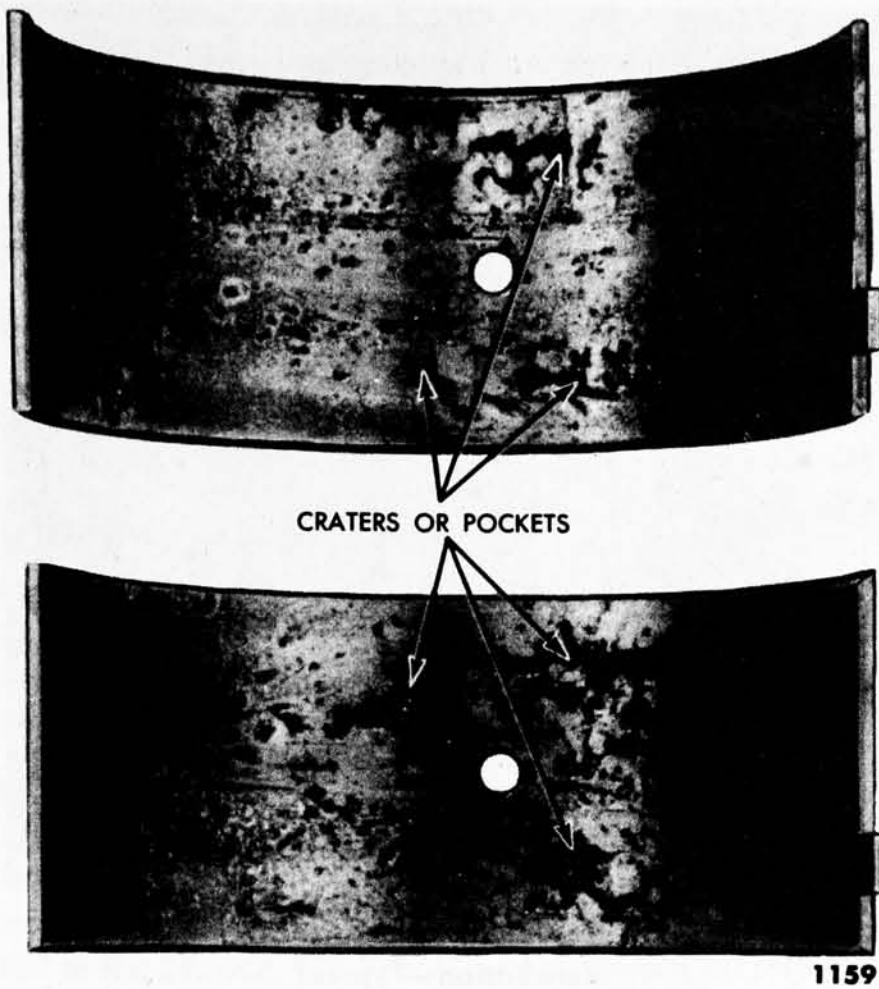
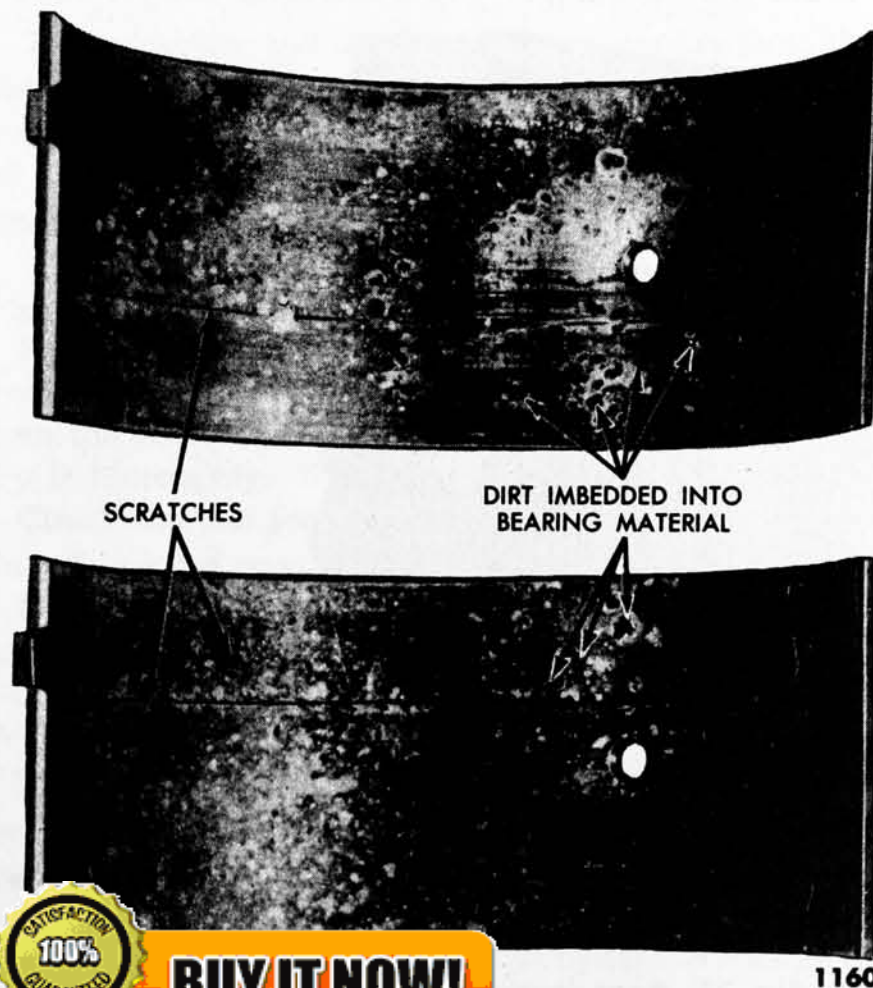

Fig. 25—Fatigue Failure of Bearing

Always reproduce the same radii in the corners of the pin or journal that existed originally. Too small a radius may result in crankshaft failure, while too large a radius will result in bearing failure.

After grinding, chamfer the oil holes, then polish the



100% SATISFACTION GUARANTEED
BUY IT NOW!
 Click Here To Order

atched by Dirt

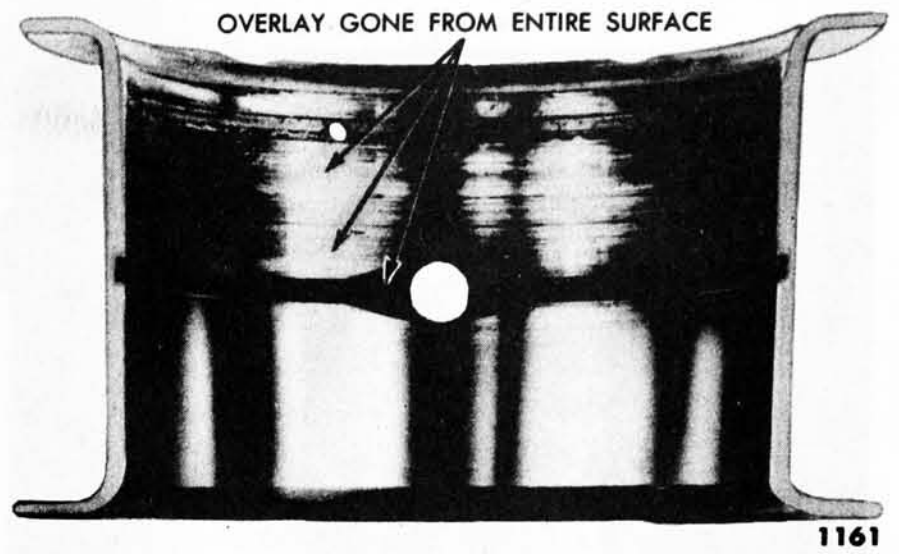

Fig. 27—Bearing Failure—Tapered Journal

pin or journal with No. 320 grit polishing cloth and engine oil. Crocus cloth may also be used as a polishing agent.

c. Main and Connecting Rod Bearings.

Steel-backed, copper-lead, or lead babbitt bearings inserts are used for both main and connecting rod bearings. Check the bearings for scratches, improper seating, evidence of radius ride, and worn overlay. Examples of bearing failures are illustrated in figs. 24, 25, 26, 27, 28, and 29. Replace all defective bearings.

(1) **FITTING MAIN AND CONNECTING ROD BEARINGS—PLASTIGAGE METHOD.** The following procedure applies to fitting main bearings with the engine either installed on a workstand or in the vehicle.

If the bearing fits are to be checked with the engine

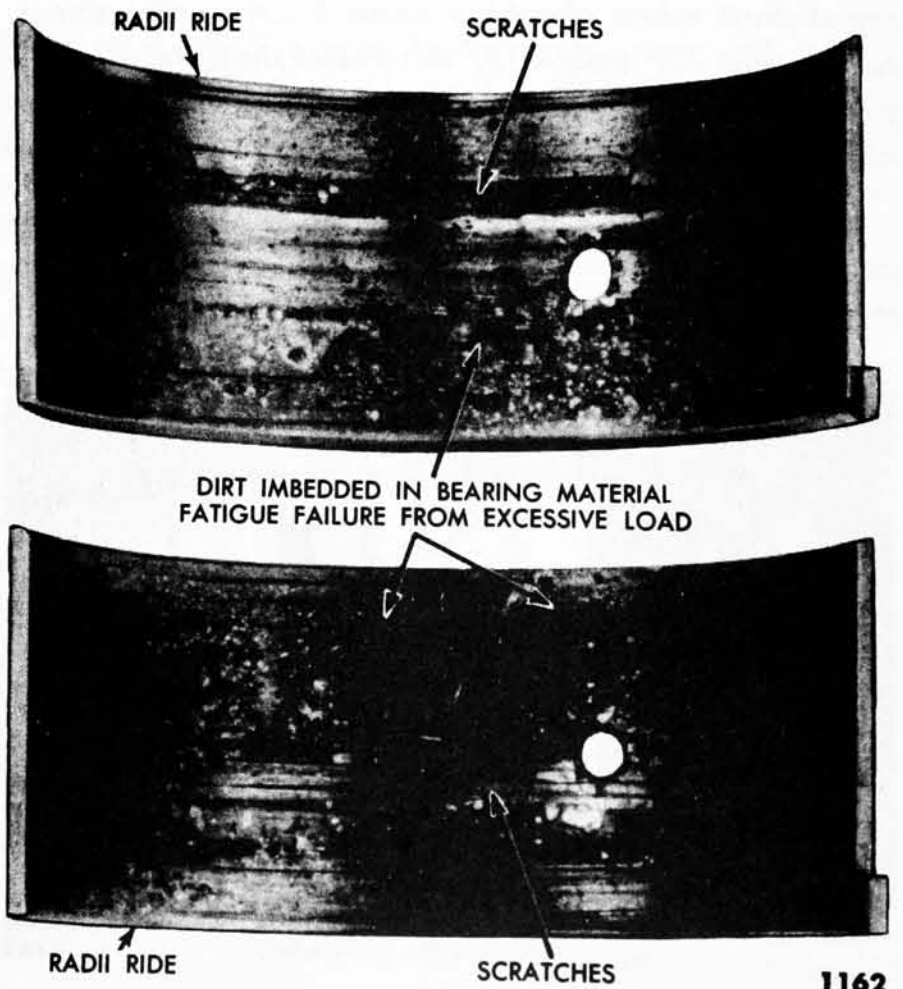

Fig. 28—Bearing Showing Radius Ride

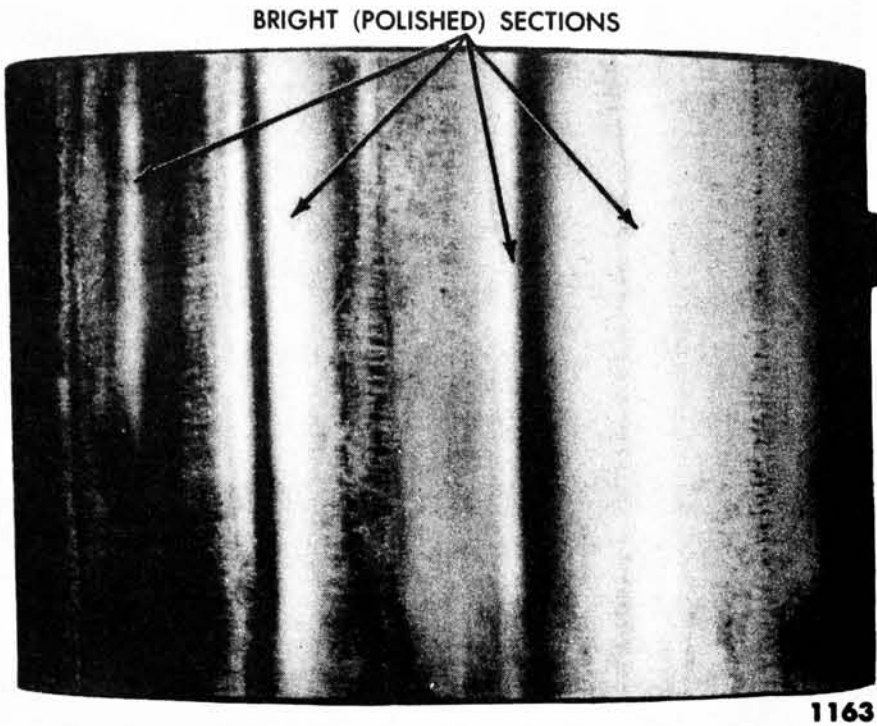
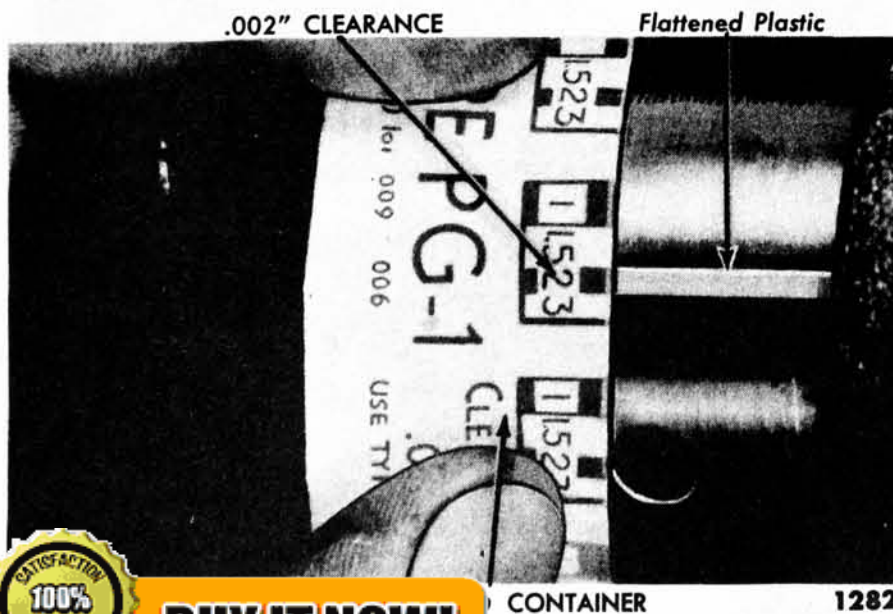

Fig. 29—Bearing Bright Spots—Improper Seating

in the vehicle, support the weight of the crankshaft with a small jack positioned to hold the crankshaft upward against the block half of the main bearing inserts. The jack should bear against the crankshaft counterweight adjoining the bearing which is being checked for clearance. The shaft can also be supported by a thin rubber pad between the cap insert and the journal of two bearings that are not being checked. Tighten the bearing cap bolts just enough to hold the crankshaft up against the upper bearing inserts.

NOTE: *It is necessary to support the weight of the crankshaft when checking main bearing clearances, to prevent the weight of the crankshaft from compressing the Plastigage, thereby providing an erroneous reading.*

Place a piece of Plastigage, the full width of the bearing cap insert, on the bearing surface (or on the crankshaft journal if the engine is inverted) about 1/4 inch off



100% SATISFACTION GUARANTEED

BUY IT NOW!

Click Here To Order

CONTAINER

Plastigage

PayPal, American Express, Discover, MasterCard, VISA

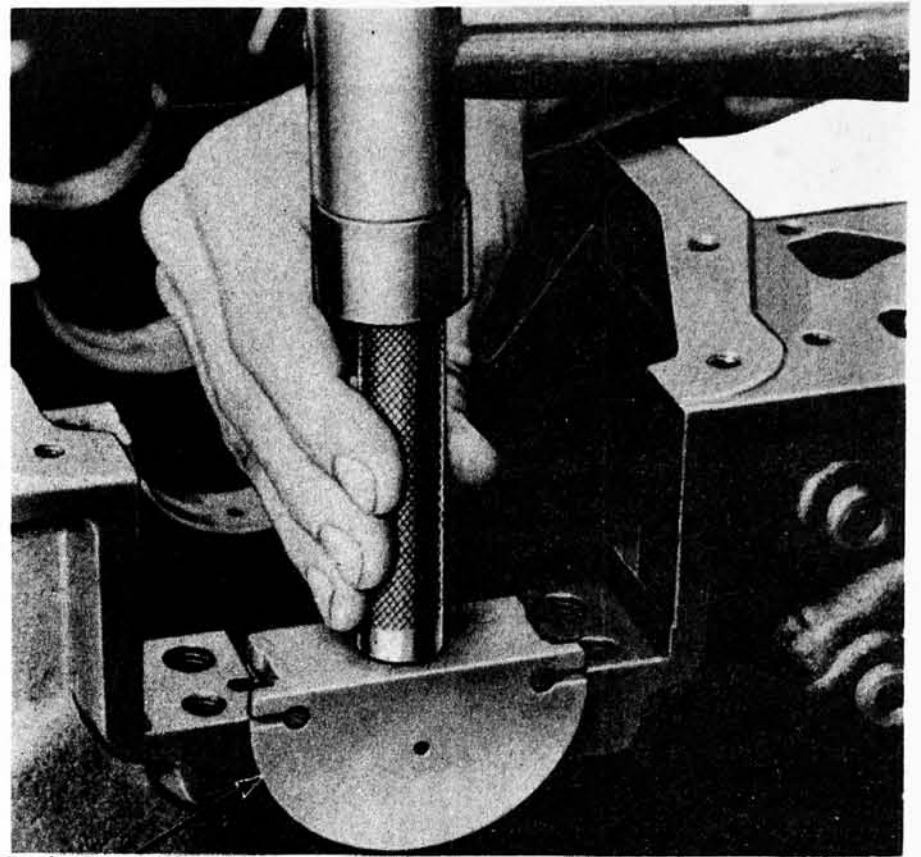

Tool—T52L-6701-AGD

Fig. 31—Rear Journal Oil Seal to Cylinder Block Installation—Typical

center. Install the cap and tighten the bolts to specifications.

CAUTION: *Do not turn the crankshaft while the Plastigage is in place.*

Remove the cap, check the width of the Plastigage, at the widest point, with the Plastigage scale (fig. 30).

If the clearance is not within limits, try another selec-

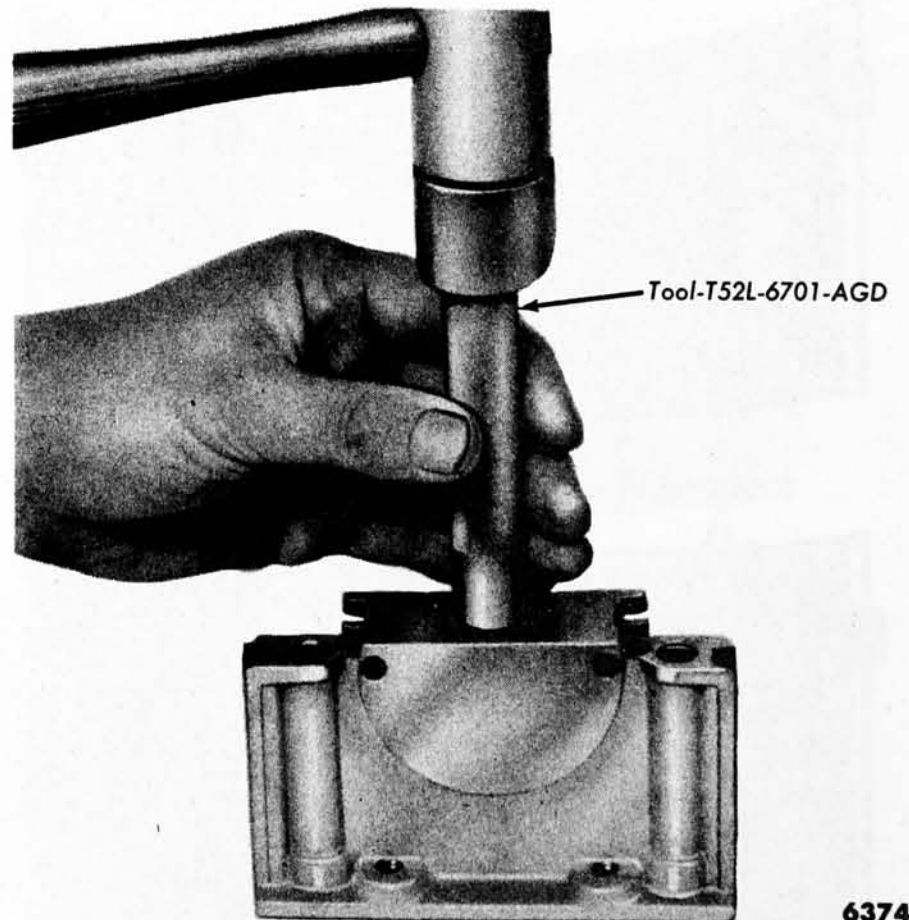

Fig. 32—Rear Journal Oil Seal to Seal Retainer Installation—Typical

tive fit bearing to bring the clearance within the desired limit. Red marked bearings increase clearance; blue marked bearings decrease clearance. If the various selective fit bearings do not bring the clearance within specifications, it will be necessary to regrind the crankshaft journals and install undersize bearing inserts.

NOTE: *Normally, main bearing journals wear evenly and are not out-of-round. However, if a bearing is being fitted to an out-of-round journal, be sure to fit the bearing to the maximum diameter of the journal. If the bearing is fitted to the minimum diameter with minimum clearance, interference may result, causing an early failure. It is not recommended that bearings be fitted to a crankshaft journal which is more than 0.001 inch out-of-round.*

(2) **ALIGNING THRUST BEARING.** Install the main bearing caps, except the thrust bearing cap, and tighten the cap bolts to specifications. Install the thrust bearing cap with the bolts finger-tight, then pry the crankshaft forward against the thrust surface of the upper half of the bearing. While holding the crankshaft forward, pry the thrust bearing cap to the rear. This will align the thrust surfaces of both halves of the bearing. Retain the forward pressure on the crankshaft, and tighten the cap bolts to specifications. Check the crankshaft end play.

(3) **REPLACING REAR MAIN BEARING OIL**

8. OIL PAN, OIL FILTER, AND OIL PUMP AND PRESSURE RELIEF VALVE

The inspection and repair procedures applicable to the above components are presented below. In addition, the removal, disassembly, assembly, and installation of the oil filter is also given, inasmuch as these procedures are applicable to all engines.

a. Oil Pan.

Remove the oil pan. Scrape any dirt or metal particles from the inside of the pan. Scrape all old gasket material from the gasket surface. Wash the pan in a solvent and dry it thoroughly.

Check the pan for cracks, holes, damaged drain plug threads, a loose, or warped gasket surface.

Repair any damage, or replace the pan if repairs cannot be made.

b. Oil Filter.

The full flow-type oil filter, used on all engines, filters the entire output of the pump before the oil enters the engine lubrication system.

The by-pass provides oil to the system in case the filter element is dirty and will not permit a sufficient flow of oil, the pressure on the inner face of the valve drops, and the pressure difference between the valve faces is enough to cause the valve to open. Oil then by-passes the element, thereby maintaining a supply of oil to the engine lubrication system.

SEALS. Remove the journal oil seal from the cylinder block. Remove the old sealing material, and clean the seal groove in the cylinder block. Repeat this procedure for the oil seal retainer cap. Remove the oil seal retainer cap to block seals.

Install a new journal oil seal in the cylinder block as shown in fig. 31. The cylinder block journal seal and the retaining cap journal seal must be cut flush without any frayed edges overlapping. Install a new journal oil seal in the oil seal retainer cap as shown in fig. 32. On 6-cylinder engines, install new retainer cap to cylinder block seals. Install the main bearing caps and inserts. Lubricate the seals with grease to reduce friction, then install the retainer in the cylinder block.

On 8-cylinder engines, install the main bearing caps and inserts, then install the rear main bearing oil seal retainer. Dip the retainer to cylinder block oil seals in light engine oil, then immediately install them in the grooves. It may be necessary to tap the seals into place for the last 1/2 inch of travel.

Check the retainer to cylinder block seal for leaks. Squirt a few drops of oil into the corners of the seals on the outside of the cylinder block. Blow compressed air into the seal corners from the inside of the block. If air bubbles appear in the oil, remove the seal retainer. Be sure all mating surfaces are clean. Install new seals and repeat the air test.

it, the pressure difference between the inner and outer faces of the valve is not great enough to overcome the spring pressure behind the valve. When the element is dirty and will not permit a sufficient flow of oil, the pressure on the inner face of the valve drops, and the pressure difference between the valve faces is enough to cause the valve to open. Oil then by-passes the element, thereby maintaining a supply of oil to the engine lubrication system.

(1) **REMOVAL.** Remove the filter from the bottom of the vehicle. Place a pan on the floor directly under the

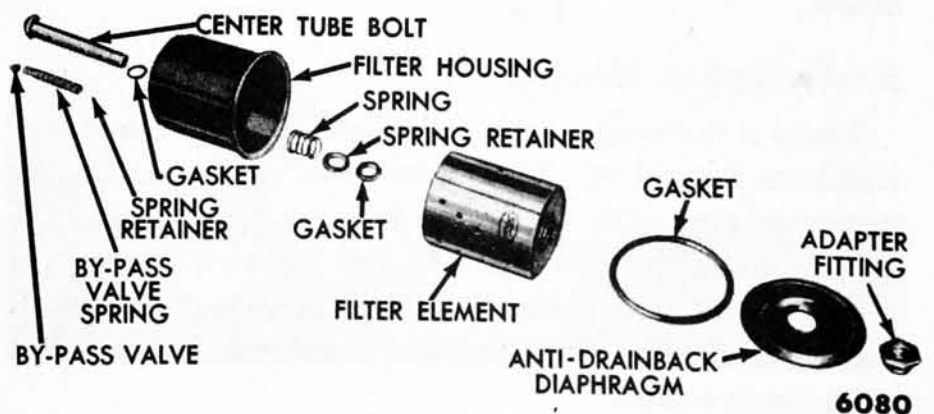

Fig. 33—Oil Filter—Disassembled—Metal Type Element Shown

100% SATISFACTORY GUARANTEED

BUY IT NOW!

Click Here To Order

PayPal, American Express, Discover, MasterCard, VISA

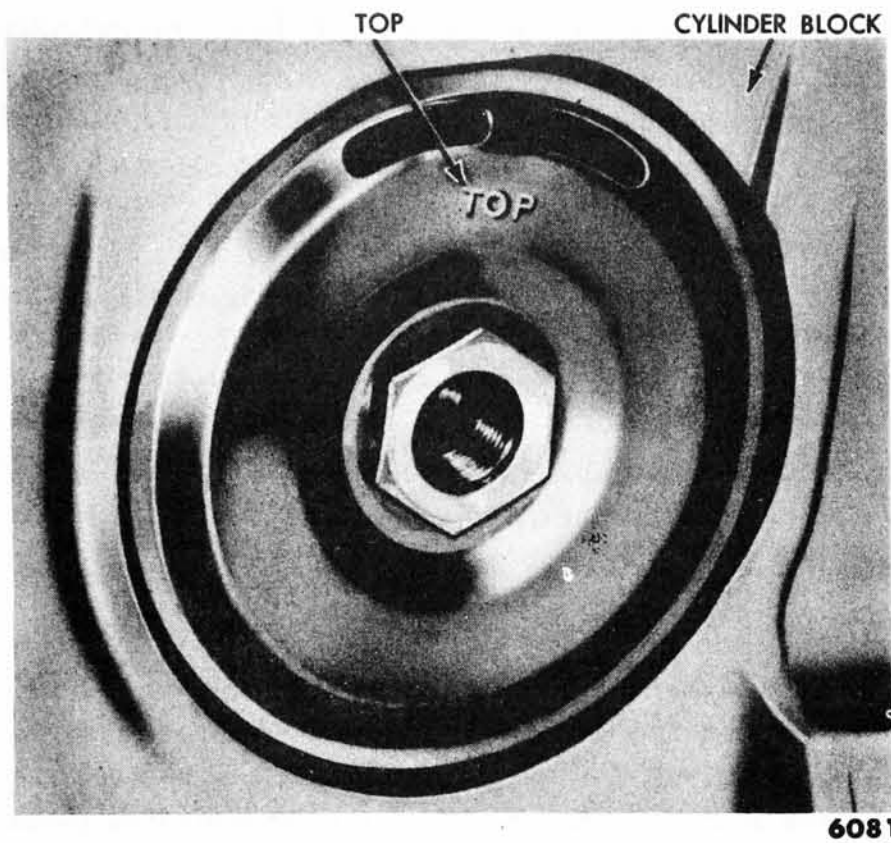

Fig. 34—Oil Filter Diaphragm Position

filter. Remove the filter center bolt, then remove the filter assembly and gasket.

NOTE: *On vehicles equipped with power steering, it will be necessary to turn the front wheels to the full right position to facilitate removal of the oil filter.*

(2) **DISASSEMBLY.** Remove the filter element, neoprene gasket (with metal type element only), spring, and seat, then remove the center bolt and fibre gasket from the cover. Discard the filter element and all gaskets. The oil filter is shown disassembled in fig. 33.

(3) **CLEANING.** Wash all parts in a solvent and dry them thoroughly. Make sure all the openings in the center bolt are clean.

(4) **ASSEMBLY.** Install a new fibre gasket on the center bolt, then place the bolt through the filter housing. Install the spring and spring seat assembly on the bolt, making sure the seat tangs are engaged in the spring. Install a new neoprene gasket and a new filter element over the center bolt. The pressed paper type element does not use the neoprene gasket.

(5) **INSTALLATION.** Be sure the two elongated holes in the oil filter diaphragm are at the top, when positioned on the block, as shown in fig. 34. Install a new neoprene gasket in the filter housing recess. Place the filter assembly in position, and thread the center bolt into the adapter finger-tight. Rotate the filter assembly slightly, in each direction, to make sure the gasket is seated evenly. Tighten the center bolt $\frac{3}{4}$ -1 complete turn (20-25 foot-pounds torque).

With the engine at normal operating temperature and operating at fast idle, check for oil leaks past the housing gasket or around the center bolt gasket. If oil leaks past the housing gasket, check the housing for proper seating. If oil leaks past the center bolt gasket, check the center bolt for proper torque or replace the gasket.

c. Oil Pump and Pressure Relief Valve.

Remove and disassemble the oil pump and pressure relief valve. Wash all parts in a solvent and dry them thoroughly. Use a brush to clean the inside of the pump housing and the pressure relief valve bore. Be sure all dirt and chips are removed. Remove all old gasket material from the pump body and cover.

Check the pump housing for damage or excessive wear. Check the pump gear teeth for damage or wear. Check the compression of the relief valve spring. Check the relief valve clearance in the relief valve bore. Check the driven shaft clearance.

Replace any worn or defective parts.

9. CYLINDER BLOCK, PISTONS, PISTON RINGS, AND CONNECTING RODS

Procedures for checking the cylinder block; for cleaning, inspecting, and fitting pistons; for fitting piston rings; and for checking connecting rod alignment are given below.

a. Cylinder Block.

Make a thorough check for cracks. Minute cracks not visible to the naked eye may be detected by coating the suspected area with a mixture of 25% kerosene and 75% light motor oil. Wipe the part dry and immediately apply a coating of zinc oxide dissolved in wood alcohol. If cracks are present, the coating will become discolored at

bore gauge. Only experienced personnel should be permitted to take these measurements.

Rebore the cylinder when the taper and/or out-of-roundness exceed the maximum allowable tolerances.

b. Pistons, Piston Pins, and Rings.

To facilitate piston removal and to avoid damage to the piston rings and ring bands, remove any ridges that may be present along with the upper part of each cylinder as follows:

Move the piston to the bottom of its travel, and place a cloth on the piston head to collect the cuttings. Remove the cylinder ridge as shown in fig. 35, according to the instructions furnished by the manufacturer of the ridge remover being used.

100% SATISFACTION GUARANTEED

BUY IT NOW!

Click Here To Order

PayPal Discover MasterCard VISA

or scores. Check the cylinder, and wear, with a cylinder

CAUTION: *Never cut into the ring travel area in excess of 1/32 inch when removing ridges.*

Remove the ridge remover from the cylinder bore. Turn the crankshaft until the piston is at the top of its stroke and carefully remove the cloth with the cuttings from the piston head. Remove the pistons.

(1) **CLEANING AND INSPECTION.** Clean the piston ring grooves with a ring groove cleaner (fig. 36). Clean the piston in solvent. Do not use a caustic cleaning solution. Make sure the oil ring slots (or holes) are clean.

Inspect pistons for fractures at the ring lands, skirt, and pin bosses. Spongy, eroded areas near the edge of the piston top, usually on the side opposite the valves, are caused by detonation, or pre-ignition.

Inspect the piston pins for signs of fracture or etching. Check the pin for proper fit in the piston and rod bushing.

(2) **REPAIRS.** Replace pistons showing signs of excessive skirt clearance, wavy ring lands, fractures or damage from detonation.

Replace piston pins showing signs of fracture or etching. Piston pins that show wear or fit loosely in the piston or rod bushing should be replaced. Replace all piston pin retainers.

(3) **FITTING PISTONS.** To fit a piston in the cylinder bore, attach a tension scale to the end of a feeler gauge ribbon (1/2 inch wide) of the proper thickness. Position the feeler on the side of the piston 90° from the piston pin hole. Invert the piston, then push the piston and feeler into the bore so the end of the piston is approximately 1 1/2 inches below the top of the block. Keep the piston pin bore parallel to the crankshaft axis. Hold the piston and pull out the feeler ribbon, noting the reading on the pull scale (fig. 37).

If the scale reading is greater than the maximum allowable pull, check for a damaged piston, try a new piston, or hone the cylinder bore to obtain the proper fit.

If the scale reading is less than the minimum allowable pull, try another piston. If none can be fitted, rebore the cylinder to the next oversize piston.

NOTE: *All pistons are the same weight, both standard and oversize; therefore, pistons of various sizes*

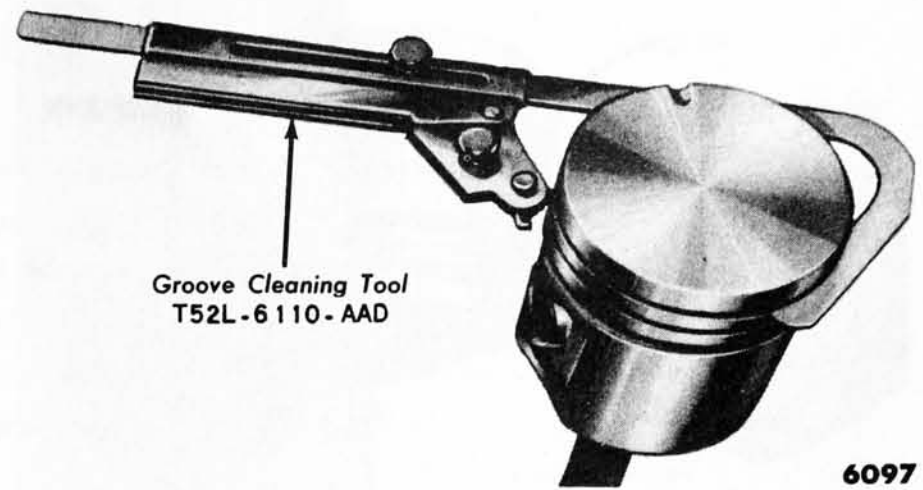

Fig. 36—Cleaning Ring Grooves

can be intermixed without upsetting engine balance. Rebore only the cylinder or cylinders which require it.

(4) **FITTING PISTON PINS.** The piston pin should have 0.0001-0.0003 inch clearance in both the connecting rod and the piston.

If the piston pin hole must be reamed, use an expansion-type, piloted reamer. Place the reamer in a vise and revolve the piston around the reamer. Set the reamer to the size of the pin bore, then expand the reamer slightly and trial ream the pin bore, using a pilot sleeve of the nearest size to maintain alignment of the bores.

CAUTION: *Take a very light cut.*

Check the reamed hole size, using the piston pin for the piston being reamed. If the bore is small, expand the



100% GUARANTEED
BUY IT NOW!
Click Here To Order

Ridge Removal

6213

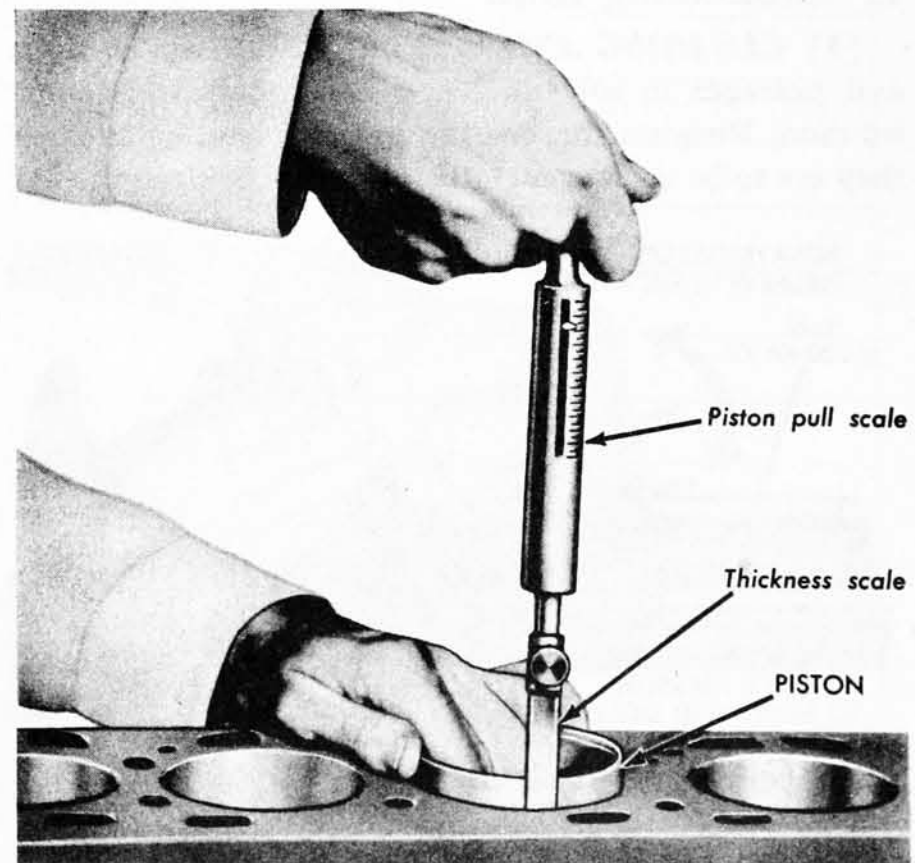

Fig. 37—Piston Fit Check

6215

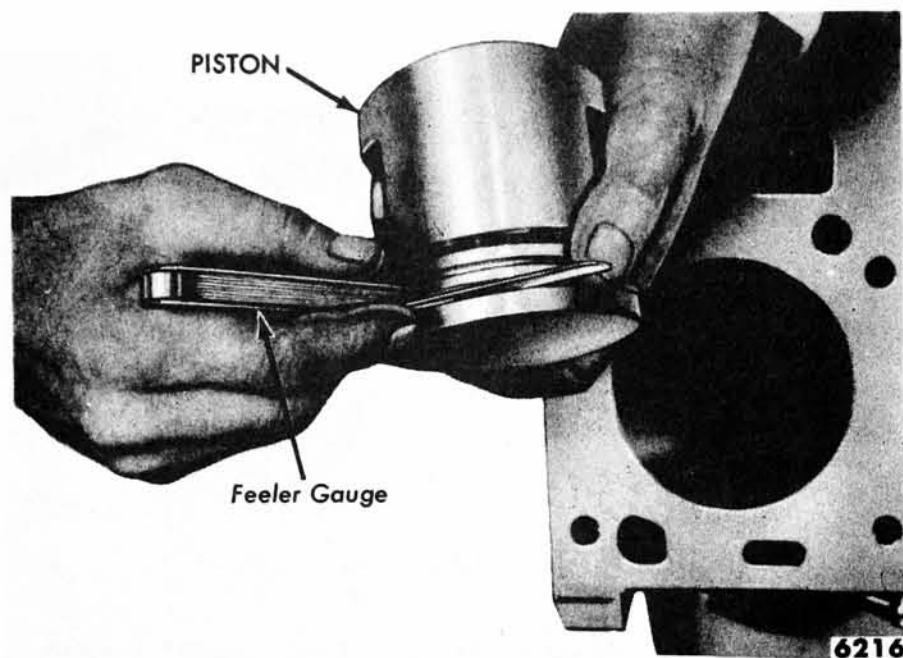

Fig. 38—Ring Clearance Check

reamer slightly and make another trial cut. Repeat the procedure until the proper fit is obtained.

(5) **FITTING PISTON RINGS.** Install the ring in the cylinder bore. Invert the piston, and use the top to push the ring about halfway down the bore to square the ring. Measure the ring gap with a feeler gauge.

Be sure to identify the rings with the piston and bore in which they are to be used.

Check the ring to groove side clearance with the ring installed on the proper piston (fig. 38). Side sealing type oil rings have no side clearance.

Whenever piston rings are installed in a used cylinder, the "glaze" on the bore should be removed to aid in ring seating.

c. Connecting Rod.

(1) **CLEANING AND INSPECTION.** Clean all parts and passages in solvent. Never use a caustic cleaning solution. Remove the bearing inserts (identify them if they are to be used again), then thoroughly clean the rod

bore and the back of the inserts. Make sure the squirt holes are clean.

Check the piston pin to bushing fit. The pin should have a 0.0001-0.0003 inch clearance in the rod bushing.

Check each connecting rod for alignment on a fixture after fitting the piston pins (fig. 39).

Inspect the rods for deep nicks, signs of fractures, and check the bore for out-of-roundness.

Check the connecting rod bolts and nuts for damaged threads, signs of nicking, or damaged corners.

(2) **REPAIRS.** If the piston pin to rod bushing clearance is excessive, ream the bushing for the next oversize pin, or replace the bushing.

If the rod is twisted or bent more than specified, it should be straightened or replaced.

Replace defective connecting rod nuts and/or bolts.

Rods with deep nicks, signs of fractures, or with the bore out-of-round more than 0.0004 inch should be replaced.

d. Fitting Connecting Rod Bearings—Plastigage Method.

Place a piece of Plastigage on the bearing surface, the full width of the bearing, about 1/4 inch off center. Install the cap and tighten the rod bolts to 45-50 foot-pounds torque.

NOTE: *Do not turn the crankshaft with Plastigage in place.*

Remove the bearing cap, and use the Plastigage scale to measure the width of the flattened piece of plastic at the widest point. Select fit bearings to obtain the proper clearance.

NOTE: *If the crankpin is out-of-round, be sure to fit the bearing to the maximum diameter of the crankpin. It is not recommended to use bearing shims of any type, or to file or lap the bearing caps in order to adjust the bearing clearance.*

If the reading is within limits, 0.0004-0.0023 (6-cylinder engine) or 0.0008-0.0027 inch (8-cylinder engine), the fit is satisfactory.

If the clearance is not within limits, try another selective fit bearing to bring the clearance within the limit. Red marked bearings increase the clearance, blue marked bearings decrease the clearance. If the various selective fit bearings do not bring the clearance within specifications, it will be necessary to regrind the crankshaft journals and install undersize bearing inserts.

Rotate the crankshaft after the bearing is installed to be sure the bearing is not too tight.

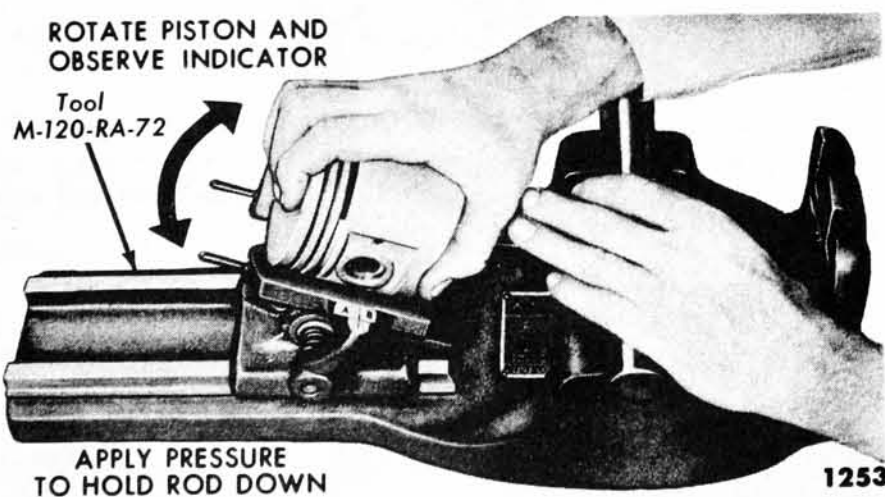

Fig. 39—Connecting Rod Alignment Check

100% SATISFACTION GUARANTEED

BUY IT NOW!

Click Here To Order

PayPal American Express Discover MasterCard VISA

Part ONE POWER PLANT

Chapter II

6-Cylinder 223 Cubic Inch (EBP) Engines

| Section | Page |
|---|------|
| 1 Engine Front Steady Rest | 28 |
| 2 Manifolds | 29 |
| 3 Cylinder Heads and Valves | 30 |
| 4 Oil Pan and Oil Pump and Pressure Relief Valve | 32 |
| 5 Crankshaft Damper, Cylinder Front Cover, and Oil Seal | 33 |
| 6 Camshaft Sprocket, Camshaft, and Bearings | 34 |
| 7 Flywheel, Crankshaft, and Bearings | 36 |
| 8 Connecting Rods, Pistons, Pins, and Rings | 37 |
| 9 Exhaust System | 39 |

The 6-cylinder 223 cubic inch car engine (figs. 1 and 2) has a bore of 3.62 inches and a stroke of 3.6 inches.

It has a compression ratio of 7.5 to 1.

1. ENGINE FRONT STEADY REST

The engine front steady rest (figs. 3 and 4) does not support any engine weight and, as its name implies, acts as a stabilizer only.

(1) **REMOVAL.** Remove the two clamp bolts at the front of the steady rest. Remove the spacer bolt that retains the insulators in the steady rest bracket. Remove the insulators. Remove two bolts from the left side and

one bolt from the right side of the engine block, then remove the bracket assembly.

(2) **INSTALLATION.** Before installing the steady rest, check the steady rest bracket for cracks or broken welds. Check the insulators for damage and loss of compressibility. Replace defective parts. Install the steady rest bracket on the cylinder block. Tighten the bolts to

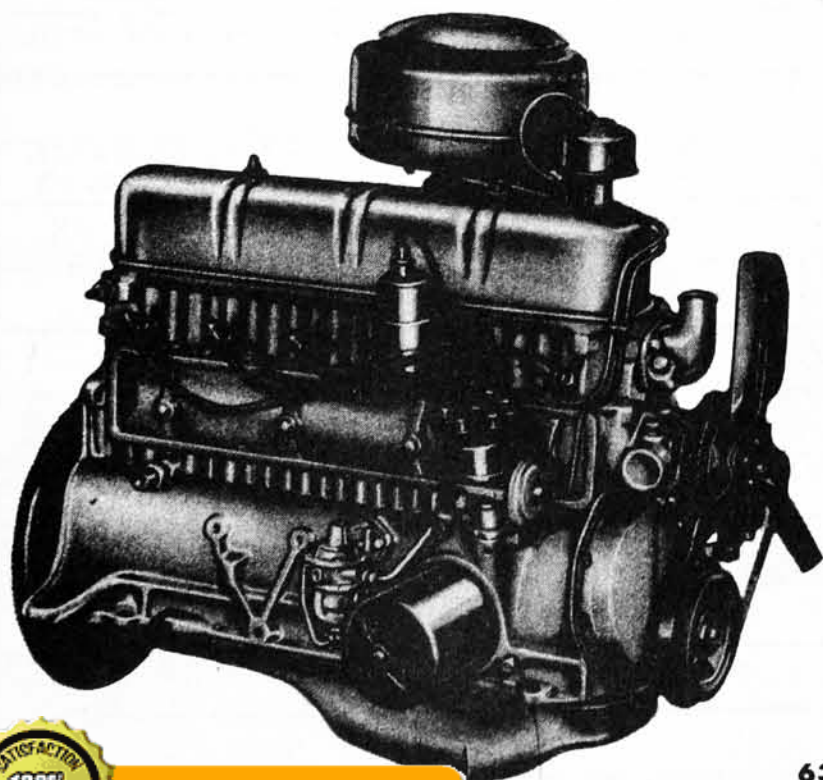

6377

Engine—Right Side

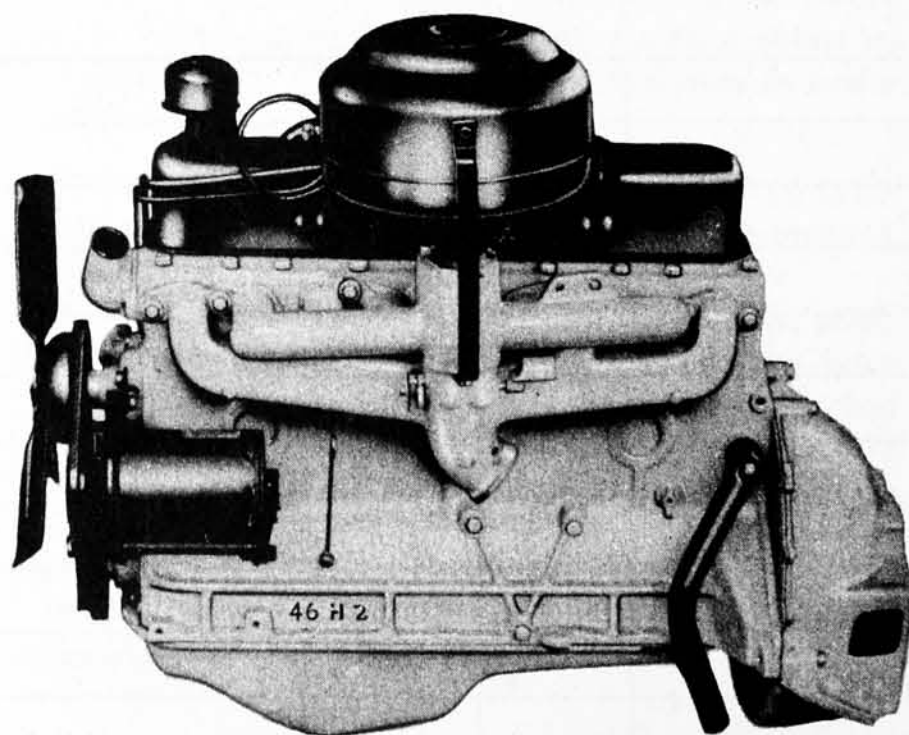

6219

Fig. 2—223 Cubic Inch Engine—Left Side View

100% SATISFACTORY GUARANTEED

BUY IT NOW!

Click Here To Order

PayPal American Express Discover MasterCard VISA

23-28 foot-pounds torque. Install the insulators, spacer bolts, and clamp bolts. Do not tighten the spacer bolt or clamp bolts. If necessary, center the spacer bolt in the frame bracket by shifting the engine front mounts in their

frame brackets. Then tighten the spacer bolt to 20-25 foot-pounds torque. Make sure engine weight is not being transferred to the steady rest insulators, then tighten the clamp bolts to 25-30 foot-pounds torque.

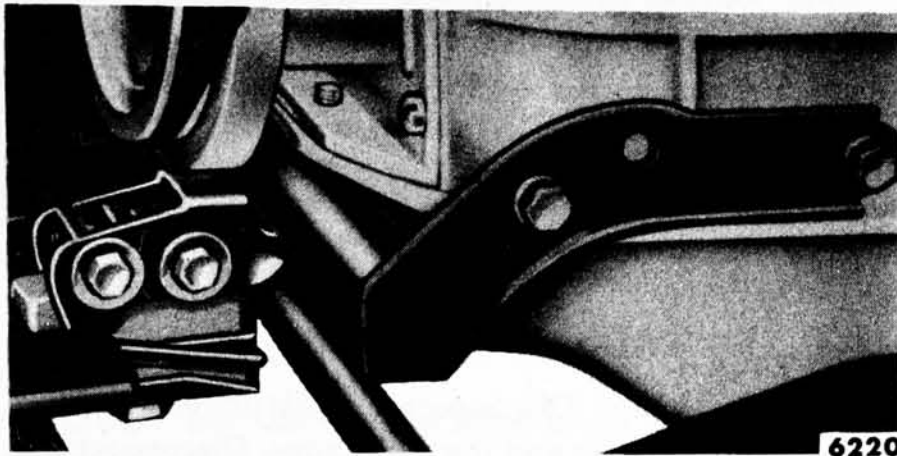

Fig. 3—Steady Rest—Left Side View

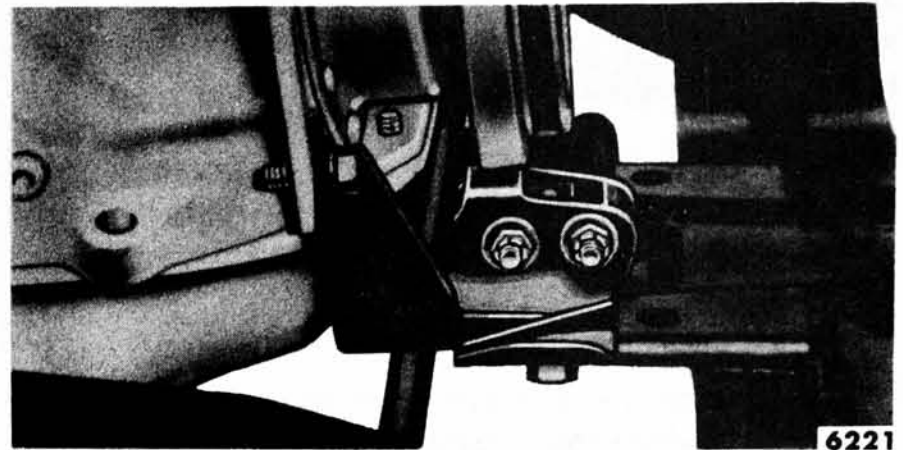

Fig. 4—Steady Rest—Right Side View

2. MANIFOLDS

A chamber is built into the intake manifold center section where the carburetor and exhaust manifold are attached. An exhaust thermostat control valve, located in the exhaust manifold, directs exhaust gases into this chamber when the engine is cold to provide for faster intake manifold warm-up.

NOTE: Do not remove manifolds when they are hot. They may warp and make reassembly difficult.

a. Removal.

Disconnect the throttle linkage at the manifold bell crank. Remove the air cleaner and the carburetor.

Disconnect the muffler inlet pipe. Remove the bolts fastening the manifold to the head, and lift the manifold assembly from the head. Remove the gaskets and inserts. Remove the nuts and bolts joining the manifolds, then separate the manifolds. A disassembled view of the manifolds is shown in fig. 5.

b. Exhaust Thermostat Valve Replacement.

The exhaust thermostat valve does not require replacement unless it becomes inoperative.

(1) **REMOVAL.** Before removing the valve assembly, note the position of the counterweight and of the thermostat spring slot with relation to the valve plate. Drive out the retaining pin and remove the counterweight from the shaft. Remove the cotter pin, washer, stop spring, and thermostat spring from the other end of the shaft. Cut shaft on both sides of the valve. Remove the valve

graphite and insert it through the valve. Rotate the shaft in the valve until the slot is positioned the same as it was originally. Weld the valve to the shaft.

Install the thermostat spring in the shaft slot, tighten the spring $\frac{3}{4}$ turn, and hook the open end of the spring over the stop pin. The spring should hold the thermostat open when the manifold is cold. Install the stop spring, washer, and cotter pin. Install the counterweight on the shaft in its original position. Drill through the shaft and install the retaining pin.

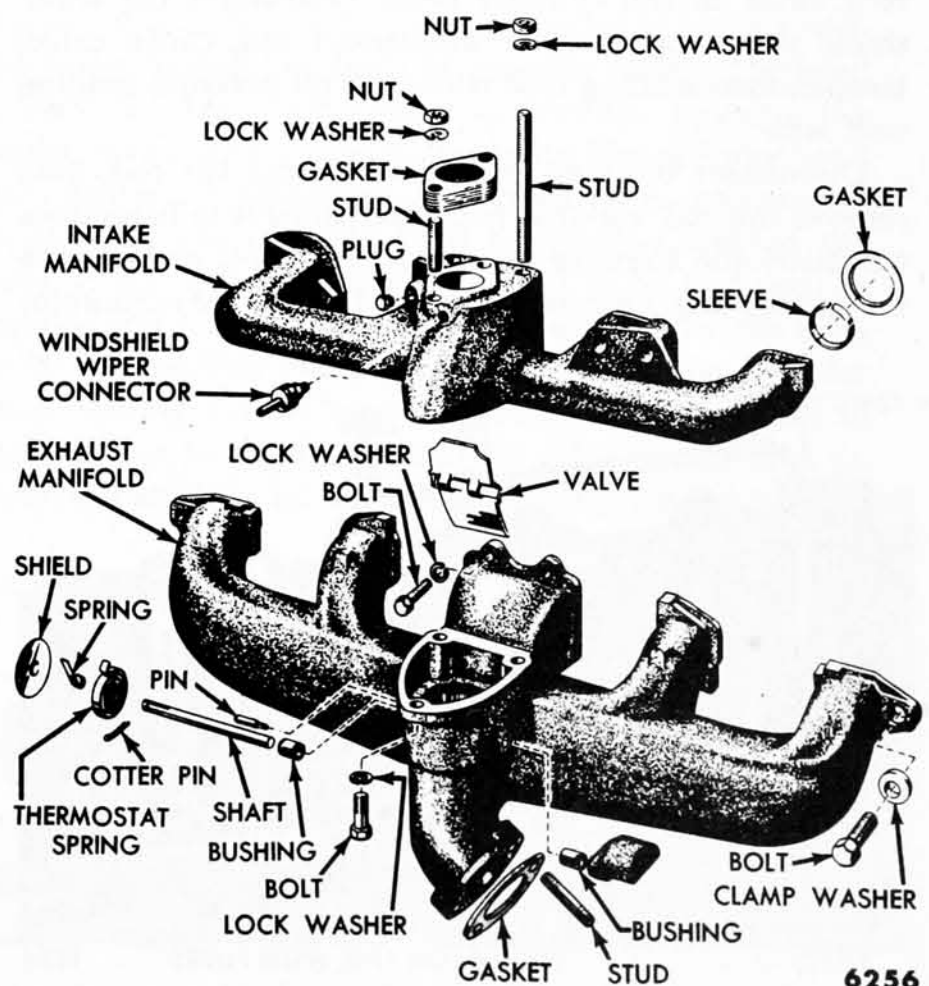

Fig. 5—Manifold—Disassembled

100% SATISFACTION GUARANTEED

BUY IT NOW!

Click Here To Order

PayPal, American Express, Discover, MasterCard, VISA

ition a new valve inside the
aft with penetrating oil and

c. Installation.

Place the intake manifold over the studs on the exhaust manifold. Install the lockwashers, nuts, and bolts, then tighten the nuts and bolts finger tight. Install new inserts and gaskets on the intake manifold parts, coat the mating surfaces lightly with graphite grease, and place the manifold assembly in position against the cylinder head.

NOTE: *Make certain the openings in the manifold assembly are in proper alignment with the openings in the cylinder head.*

3. CYLINDER HEADS AND VALVES

The cylinder head is cast from the same high grade iron as is used for the cylinder block. Cylinder head distortion is kept to a minimum because the expansion and contraction due to temperature change is the same for both head and block. The head carries the valves and valve rocker arm mechanism, the manifold assembly, and the water outlet.

Valve guides are an integral part of the cylinder head. Valves with oversize stems are available for service when the valve guides become worn or scored. Both the intake and exhaust valve assemblies are the rotating-type, and both valve assemblies incorporate umbrella-type valve stem seals.

a. Cylinder Head Removal.

Drain the cooling system. Remove the air cleaner, then tape the carburetor air horn closed. Disconnect the battery cable at the cylinder head. Disconnect the windshield wiper vacuum line accelerator rod, choke cable, temperature sending unit wire, and oil pressure sending unit wire.

Disconnect the high tension wire from the coil, then remove the coil from the head and allow it to hang from the distributor. Remove the spark plug wires and remove the spark plugs. Disconnect the fuel line at the carburetor

Install the manifold hold-down bolts and lockwashers. Tighten the bolts to 23-28 foot-pounds torque, tightening from the center to the ends. Tighten the bolts and nuts joining the intake and exhaust manifolds to 23-28 foot-pounds torque. Install a new exhaust outlet flange gasket, and position the muffler inlet pipe over the studs. Install the nuts and lockwashers, and tighten the nuts to 23-28 foot-pounds torque.

Connect the throttle linkage. Install the carburetor and connect the carburetor linkage. Install the air cleaner.

and the fuel pump. Disconnect the distributor vacuum line at the carburetor and the distributor. Disconnect the manifold line at the manifold and booster pump, then remove all three lines. Remove the valve rocker arm cover.

Remove the cap screw and clip from the Number 6 rocker arm support bracket. Pull the oil feed line out of the bracket, then pull it out of the block with pliers (fig. 6). Be careful not to damage the line.

Loosen all rocker arm adjusting screws to remove the valve spring load from the rocker arms, then remove the rocker arm assembly.

Remove the valve push rods in sequence. Identify them so they can be installed in their original position.

Disconnect the upper radiator hose at the radiator. Remove the distributor cap. Remove the manifold hold down bolts, and pull the manifold assembly away from the head allowing it to be supported by the muffler inlet pipe.

NOTE: *Brace the intake manifold assembly so the inlet pipe will not be damaged.*

Install the cylinder head holding fixtures (which are shown installed on the head in fig. 7) for convenience in lifting the head and to protect the gasket surfaces.

Remove all cylinder head bolts. Install the cylinder head guide studs shown in fig. 8. Lift the cylinder head assembly off the engine.

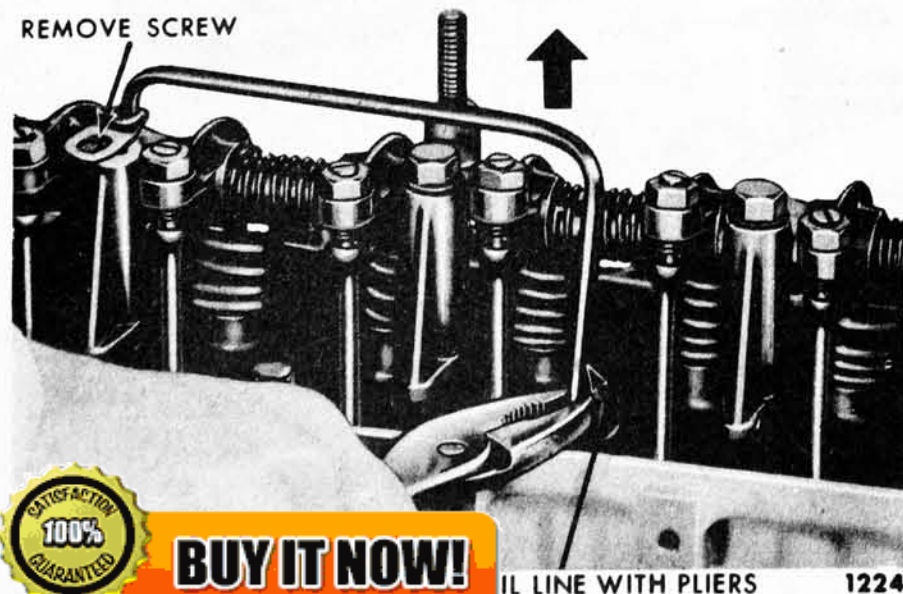

Removal

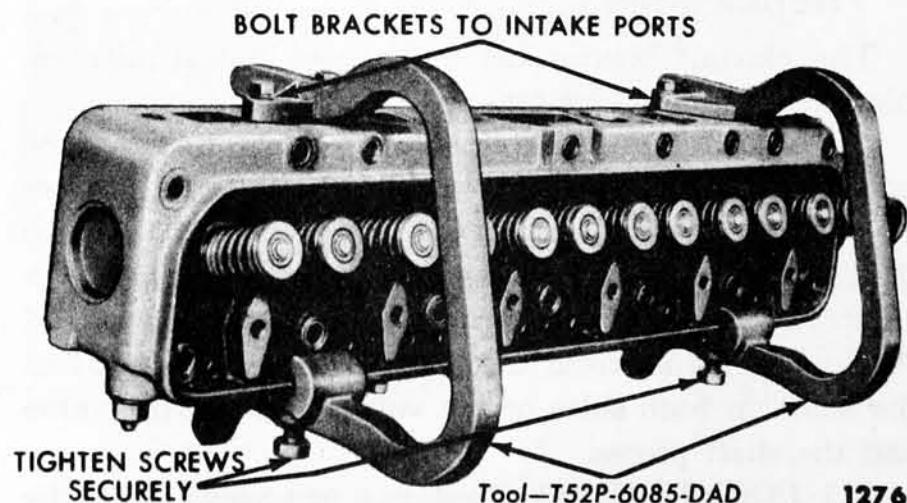

Fig. 7—Cylinder Head Holding Fixture

100% SATISFACTION GUARANTEED

BUY IT NOW!

[Click Here To Order](#)

PayPal American Express Discover MasterCard VISA

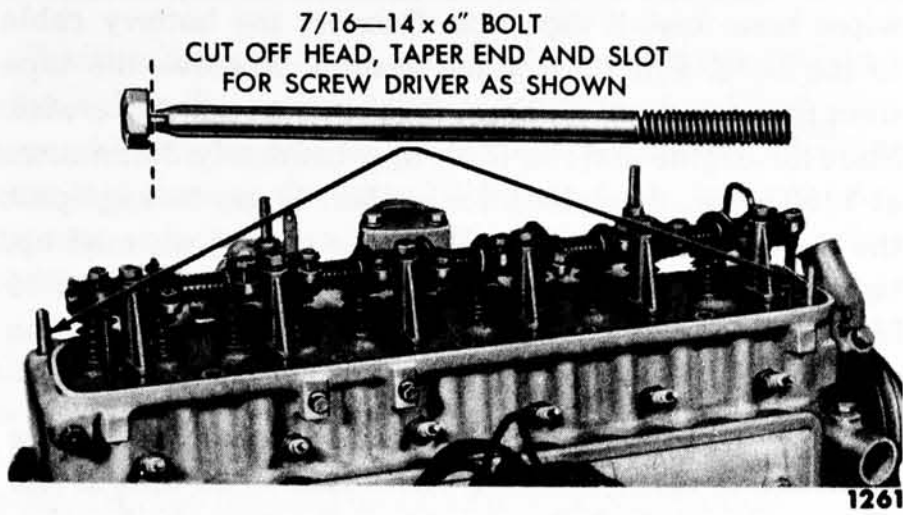

Fig. 8—Cylinder Head Guide Studs

CAUTION: Do not pry the head loose with a screwdriver or wedge. The gasket surfaces of the head and block must not be scratched or gouged.

b. Cylinder Head Disassembly.

Pull the oil drain line and clip out of the Number 1 bracket. Remove the cotter pins at each end of the rocker arm shaft, and remove the flat washers and spring washers. Remove the plugs at each end of the shaft. Slide the rocker arms, springs, and brackets off the shaft. Be sure to identify the parts.

Clean the carbon out of the combustion chambers before removing the valves. Compress the valve springs with the tool shown in fig. 9, remove the valve stem locks, and release the springs. Remove the sleeve, valve spring retainer, spring, and valve. Discard the umbrella-type valve stem seals. Identify all valve parts.

c. Cylinder Head Assembly.

Oil all moving parts with engine oil. Lay out the shaft and rocker mechanism parts as shown in fig. 10. Install a flat washer, spring washer, another flat washer, plug (cup side out), and a cotter pin in one end of the shaft. The plug is an interference fit in the shaft; however, do not peen the plug. Install the parts in the order shown in fig. 10.

Install each valve in the port from which it was re-

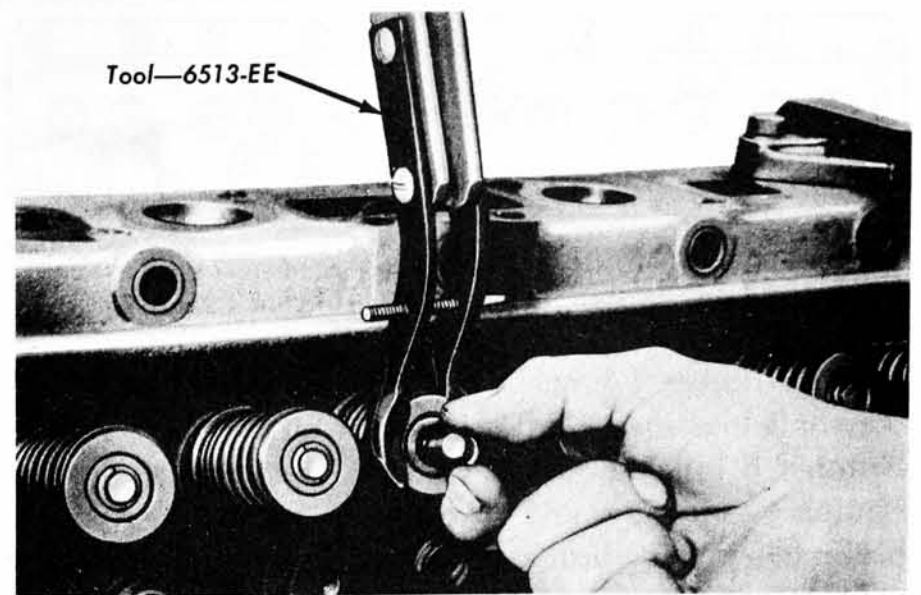

Fig. 9—Valve Stem Lock Removal

moved or to which it was fitted. Install a new umbrella-type seal on the valve. Install the valve spring with the closed coil near the head, then install the valve spring retainer, and sleeve. Compress the spring, and install the locks as shown in fig. 9.

d. Cylinder Head Installation.

Apply a coating of cylinder head gasket sealer (8A-19554-B) to both sides of the new gasket. Use the brush furnished to spread the sealer evenly over the entire gasket surface. Position the gasket over the guide studs on the cylinder block. Lift the cylinder head over the guides and slide the head down carefully.

Before installing the cylinder head bolts, coat the threads of each bolt with a small amount of water resistant sealer. Install two bolts at opposite ends of the head to hold the head and gasket in position. Remove the guides, then install the remaining bolts. The cylinder head bolt tightening procedure is performed in progressive steps. After the cylinder head is installed, tighten the bolts, in the sequence shown in fig. 11, to 55 foot-pounds torque (cold). Repeat the operation, and tighten the bolts to 65 foot-pounds torque (cold). Remove the cylinder head holding fixture brackets. Install the push rods in their proper location. Position the valve rocker arm assembly, install the oil drain line, clip, and retaining screw

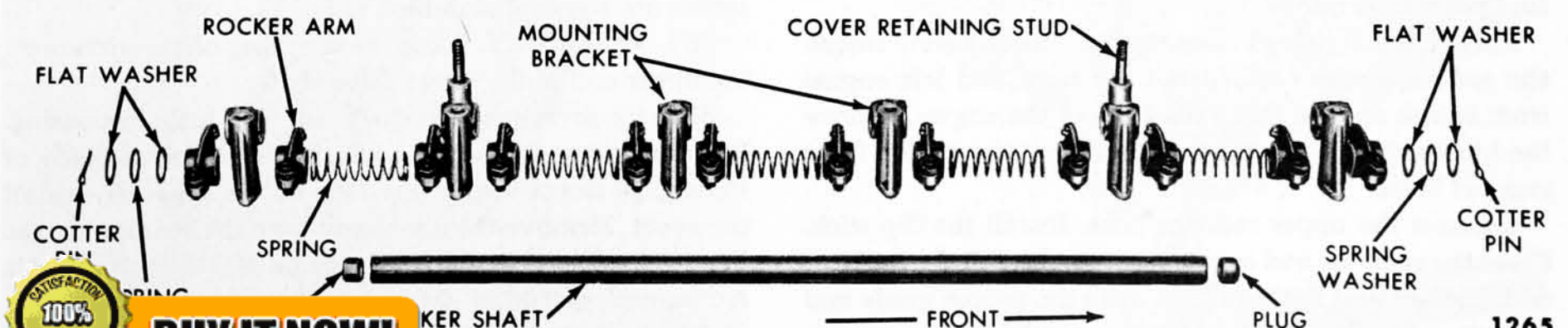

Fig. 10—Rocker Mechanism—Disassembled

100% SATISFACTION GUARANTEED

BUY IT NOW!

Click Here To Order

PayPal, American Express, Discover, MasterCard, VISA

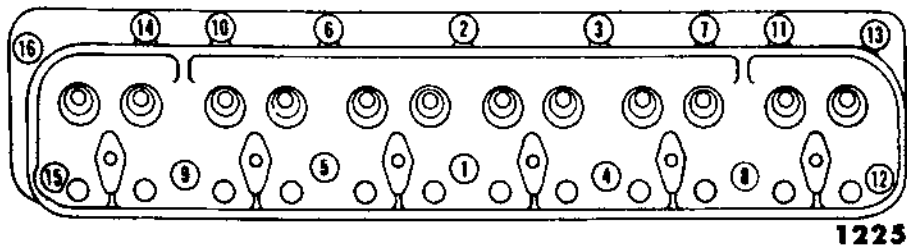

Fig. 11—Cylinder Head Bolt Tightening Sequence

on the Number 1 bracket, make sure the oil line enters the shaft locating hole. Position the oil feed line on the Number 6 bracket, install the bolt, then tighten all the retaining bolts to 45-55 foot-pounds torque. Perform a preliminary valve lash setting.

Install the manifold assembly, the ignition coil, and spark plugs. Connect the spark plug wires, temperature sending unit wire, and oil pressure sending unit wire. Connect the upper radiator hose. Install the accelerator rod. Position the two vacuum lines and fuel line on the engine, then connect the lines. Install the distributor cap. Connect the high tension lead to the coil. Connect the windshield

4. OIL PAN, OIL PUMP, AND PRESSURE RELIEF VALVE

Procedures for the removal and installation of the above components are presented below.

a. Oil Pan.

(1) **REMOVAL.** Drain the crankcase. Remove the oil dip stick. Drain the coolant from the engine and radiator. Disconnect the upper radiator hose at the engine. Remove the engine front support bolts. Remove the engine steady rest. Raise the front of the engine about two inches. Remove the left and right engine front splash aprons. Block the engine and lower the engine on the block.

Remove the flywheel housing inspection cover. Remove the oil pan retaining screws and remove the pan and gasket.

(2) **INSTALLATION.** Make sure the gasket surface of the block is clean and free from burrs. Coat the block surface and oil pan gasket surface with sealer and position the gasket on the oil pan, hold the pan in place against the block, and install a screw, finger tight, at each end of the pan. Install the remaining screws, then tighten the screws from the center outward in each direction to 12-15 foot-pounds torque.

Install the flywheel housing inspection cover. Install the engine steady rest. Install the right and left engine front splash aprons. Raise the front of the engine, remove the blocks then lower the engine. Install the engine front support bolts.

Connect the upper radiator hose. Install the dip stick. Close the radiator and engine drain cocks. Fill the radiator with coolant and the crankcase with the proper grade and weight of oil. Run the engine until normal operating temperature is reached and check for oil and

wiper hose. Install dip stick. Connect the battery cable to the head. Fill the cooling system. Remove the tape from the carburetor air horn, then connect the choke wire. Start the engine and run it for approximately 30 minutes at 1200 r.p.m., then check for coolant or gas leakage past the cylinder head gaskets. With the engine warmed up, tighten the cylinder head bolts, in proper sequence, to 75 foot-pounds torque (hot). Check the valve lash with the engine idling after the engine is thoroughly warmed.

NOTE: After the cylinder head bolts have been tightened to specifications, additional tightening is not necessary and the bolts should not be disturbed.

Coat one side of the valve chamber cover gasket with oil resistant rubber cement, and lay the cemented side of the gasket in place in the cover. Install the valve chamber cover, making sure that the gasket seats evenly all around the head. Install and tighten the retaining nuts to 2-5 foot-pounds torque. Be sure the rubber washers are in place in the cover.

coolant leaks.

b. Oil Pump and Pressure Relief Valve.

A gear-type oil pump is mounted inside the crankcase in line with the distributor.

The pump is driven by means of a hex drive shaft. The shaft is pinned in the end of the distributor drive shaft by a roll pin, and the other end seats in the end of the oil pump drive shaft. The pressure relief valve is incorporated in the oil pump housing.

(1) **REMOVAL.** Drain the oil and remove the oil pan. Remove the two nuts and lockwashers retaining the pump to the cylinder block. Remove the pump and gasket.

(2) **DISASSEMBLY.** Remove the screen assembly retaining screws, the screen assembly, and gasket. Remove the cover retaining screws, cover, and gasket. Push the pump drive shaft and drive gear assembly from the pump housing. Remove the driven gear. Remove the oil pressure relief valve plug, spring, and plunger.

Remove the snap wire retaining the pump screen, and remove the screen from the housing. The oil pump and screen are shown disassembled in fig. 12.

(3) **ASSEMBLY.** Place the snap ring on the groove on the upper end of the lower drive shaft.

Slide the drive gear and shaft assembly into the housing. Position the gasket on the housing, then lay a piece of Plastigage directly over the face of the gear and install the cover. Remove the cover and note the reading on the Plastigage. The gear end play may be 0.0015 - 0.0055 inch. A clearance of 0.0015 - 0.003 inch, however, is preferred.

An alternate method of checking gear end play is as follows:

BUY IT NOW!
 Click Here To Order





Position the gasket on the housing, and lay a straight-edge across the gasket directly over the gear. Check the gear end play by placing the tip of a dial indicator on the gear and moving the gear back and forth, between the housing and straightedge. Subtract 0.0005 inch from the reading to allow for the compression of the gasket.

Install the pump driven gear, the cover plate gasket, the cover plate, and the retaining screws. Tighten the screws to 12-15 foot-pounds torque.

Install the pressure relief valve plunger, spring, and plug. Tighten the plug to 33-38 foot-pounds torque.

Install the screen in the screen cover and secure it with the snap wire. Install the gasket, screen and cover assembly, and retaining screws. Tighten the screws to 10-12 foot-pounds torque. Rotate the pump shaft by hand to make sure it turns freely.

(4) **INSTALLATION.** Place a new gasket on the retaining bolts, slide the pump mounting flange over the retaining bolts, and install the lockwashers and nuts. Tighten the nuts to 30-35 foot-pounds torque.

Install the oil pan. Fill the crankcase with the proper grade and quantity of oil.

Run the engine, and check oil pressure to determine whether or not the pump is operating properly.

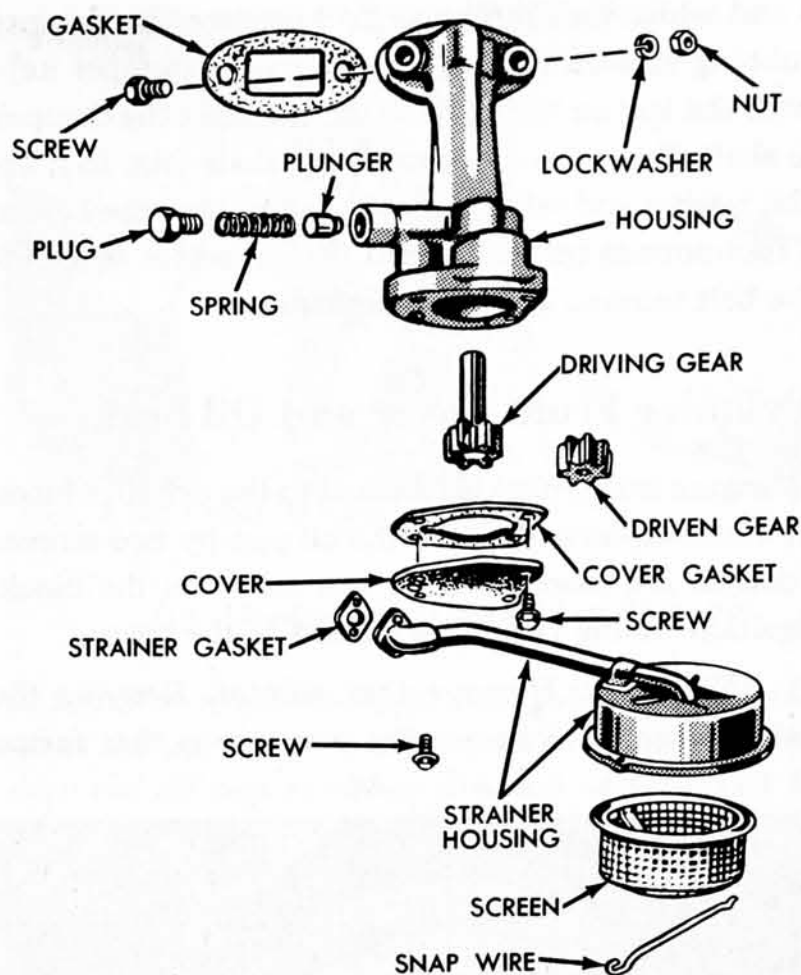

6331

Fig. 12—Oil Pump—Disassembled

5. CRANKSHAFT DAMPER, CYLINDER FRONT COVER, AND OIL SEAL

The removal and installation procedures applicable to the above components are presented below.

a. Crankshaft Damper.

The damper (fig. 13) is keyed to the crankshaft and

VIBRATION DAMPER TIMING POINTER TIMING MARKS

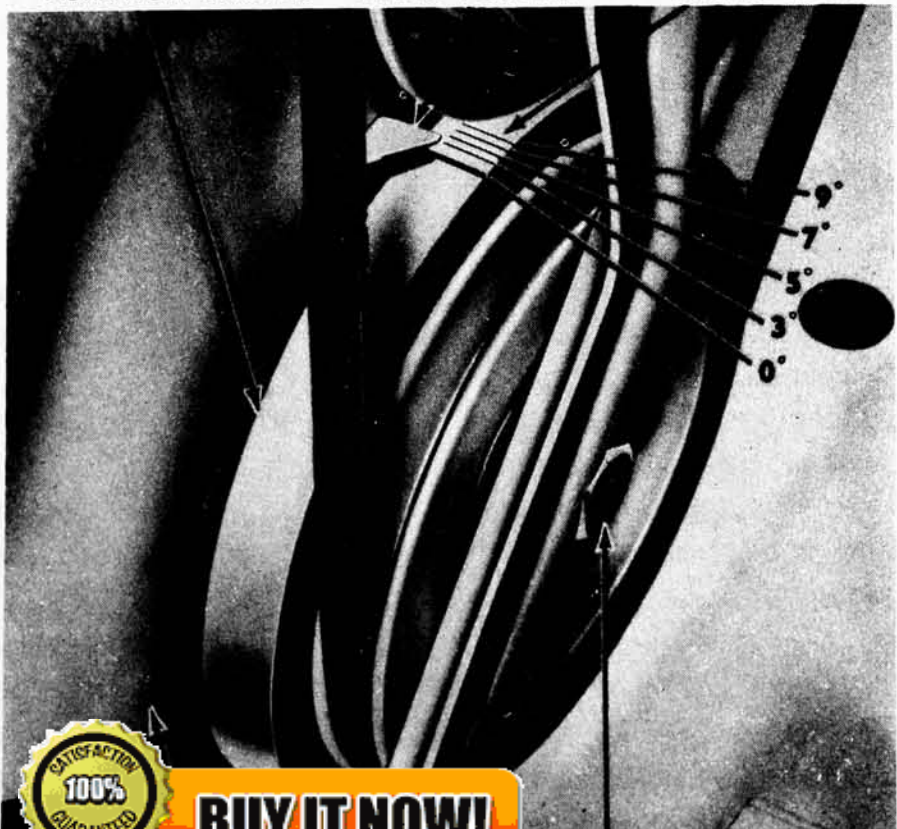

RETAINING SCREW 6122

Damper

retained with a capscrew and washer. Two threaded holes are provided in the damper to facilitate its removal.

(1) **REMOVAL.** Remove the radiator. Remove the generator belt. Remove the retaining bolt and washer from the end of the crankshaft. Install the tool shown in fig. 14, and pull the damper from the crankshaft.

(2) **INSTALLATION.** Lubricate the crankshaft with

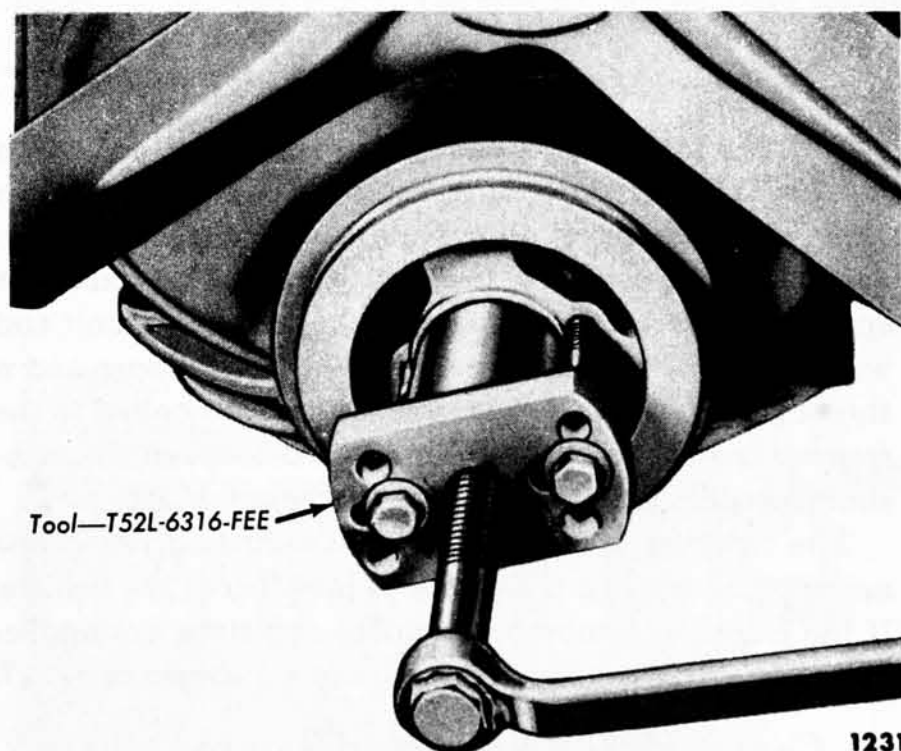

1231

Fig. 14—Damper Removing Tool

100% SATISFACTION GUARANTEED

BUY IT NOW!

[Click Here To Order](#)

PayPal American Express Discover MasterCard VISA

an oil and white lead mixture and lubricate the damper seal rubbing surface with grease. Align the damper keyway with the key on the crankshaft, and start the damper on the shaft. Press the damper on the shaft (fig. 15). Install the washer and retaining bolt, and tighten the bolt to 85-95 foot-pounds torque. Install the generator belt. Adjust the belt tension. Install the radiator.

b. Cylinder Front Cover and Oil Seal.

The engine front cover is fastened to the cylinder block by ten hex-head screws and to the oil pan by two screws. Two dowels are used to locate the cover on the block. The ignition timing pointer is welded to the cover.

(1) **REMOVAL.** Remove the radiator. Remove the crankshaft damper. Remove the two screws that fasten

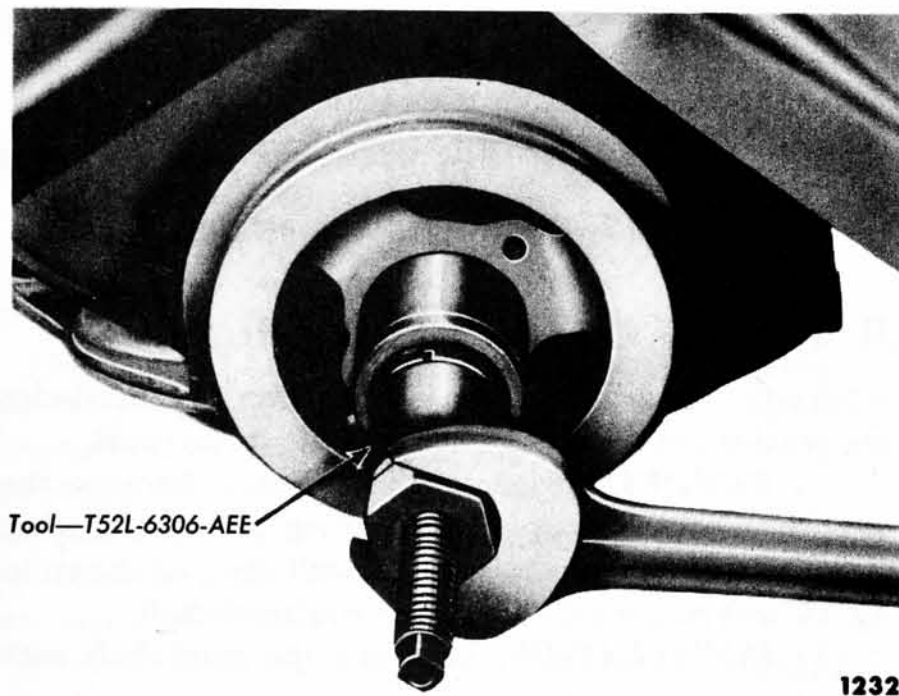

Fig. 15—Damper Installation

the front end of the oil pan to the cover and loosen the remaining screws slightly. Remove the cover retaining screws, the cover, and the gasket.

(2) **OIL SEAL REPLACEMENT.** Drive out the old seal with a pin punch, then clean out the recess in the cover. Coat a new seal with grease, then install the seal with the tool shown in fig. 16. Drive the seal in until it is fully seated in the recess. Check the seal to be sure the spring did not come out during the installation.

(3) **INSTALLATION.** Coat the block surface and cover with sealer, then position a new gasket on the block, place the cover on the cylinder block, and install the retaining screws. Tighten the screws to 6-9 foot-pounds torque. Install the damper. Install the radiator. Install the two screws that fasten the oil pan to the front cover and tighten all cover screws evenly working from the center outward in each direction.

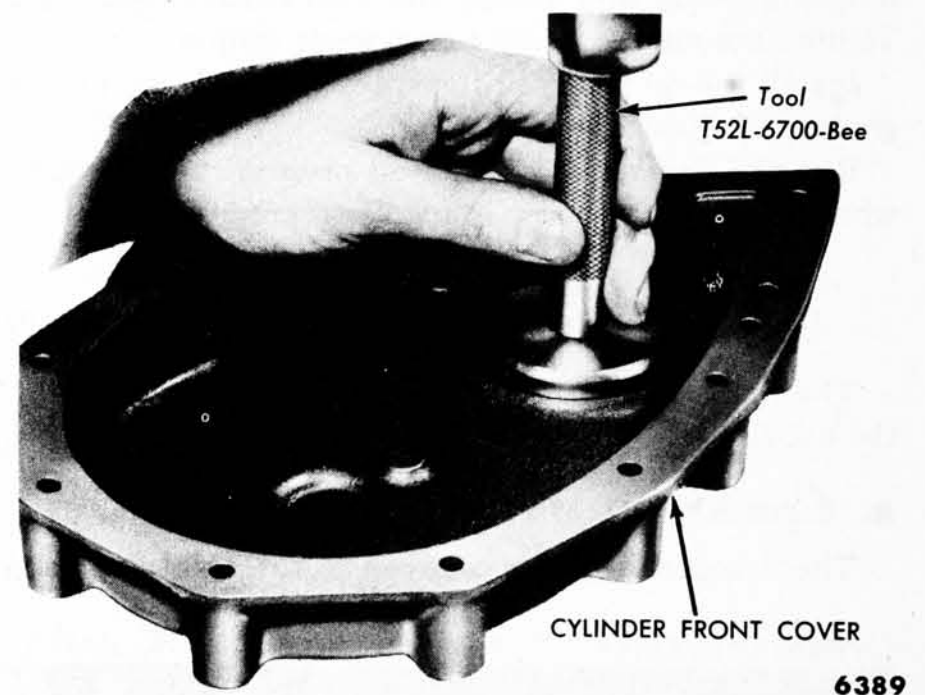

Fig. 16—Oil Seal Installation

6. CAMSHAFT SPROCKET, CAMSHAFT, AND BEARINGS

The camshaft, supported by four bearings pressed into the block, is driven by a sprocket and timing chain in mesh with a sprocket on the crankshaft. An eccentric on the camshaft operates the fuel pump. The camshaft sprocket, keyed to the camshaft, is retained by a bolt and washer. Camshaft thrust is controlled by a spacer and a thrust plate behind the sprocket, the plate is bolted to the front of the block. The plate is located between the camshaft sprocket and the shoulder on the camshaft.

The removal and installation procedures given below are applicable when the engine is installed in the vehicle. If the engine is removed, eliminate any steps not applicable. The camshaft and related parts are shown in fig. 17.

radiator, crankshaft damper, and cylinder front cover.

(1) **REMOVAL.** Before removing the camshaft sprocket, it is advisable to align the timing marks as shown in fig. 18.

Remove the camshaft sprocket retaining bolt and washer. Slide the camshaft sprocket, timing chain, and crankshaft sprocket forward until the camshaft sprocket comes off the camshaft. Do not lose the key from the camshaft.

(2) **INSTALLATION.** Place the timing chain over the crankshaft sprocket, and insert the camshaft sprocket in the timing chain so the timing marks of both sprockets are properly positioned (fig. 18). Align the key in the camshaft with the camshaft sprocket keyway, and slide the assembly into position. Recheck the timing. Install the washer and retaining bolt. Tighten the bolt to 45-50 foot-

100% SATISFACTION GUARANTEED

BUY IT NOW! and Timing Chain.

Click Here To Order

chain accessible, remove the

PayPal American Express Cards Discover NOVUS MasterCard VISA

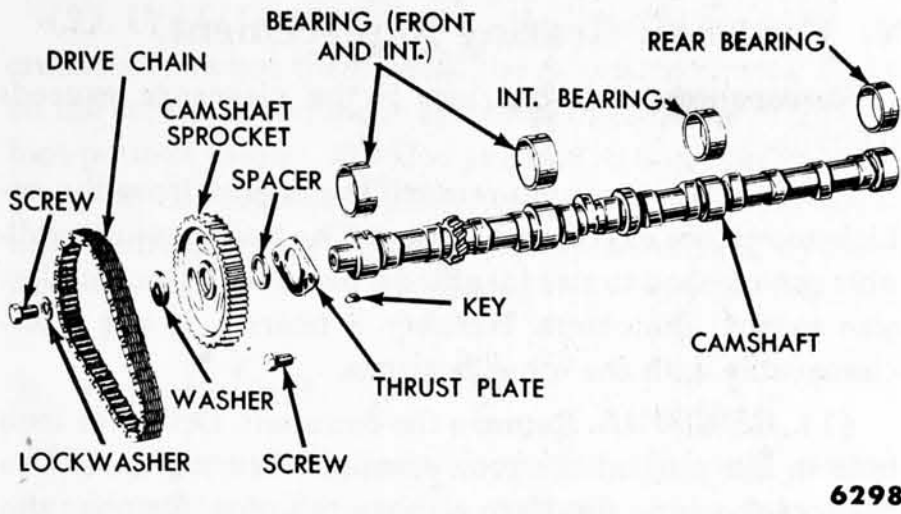

6298

Fig. 17—Camshaft and Related Parts

pounds torque.

Install the cylinder front cover, crankshaft damper, and radiator.

b. Camshaft.

Camshaft replacement is necessary when the lobes are worn to such an extent that cam lift intake and exhaust is less than 0.242 inch. If lobe wear is encountered, mating tappet or tappets must be replaced. Check push rods for straightness before replacing camshaft for lobe wear.

(1) **REMOVAL.** Remove the radiator. Remove the crankshaft damper and the cylinder front cover. Remove the rocker arm cover and the valve push rod cover. Remove the rocker arm assembly and all push rods. Lift the tappets and hold them with window regulator spring retainers (bend the closed end approximately 30 degrees) or spring clothes pins.

NOTE: *If the engine is mounted on a work stand,*

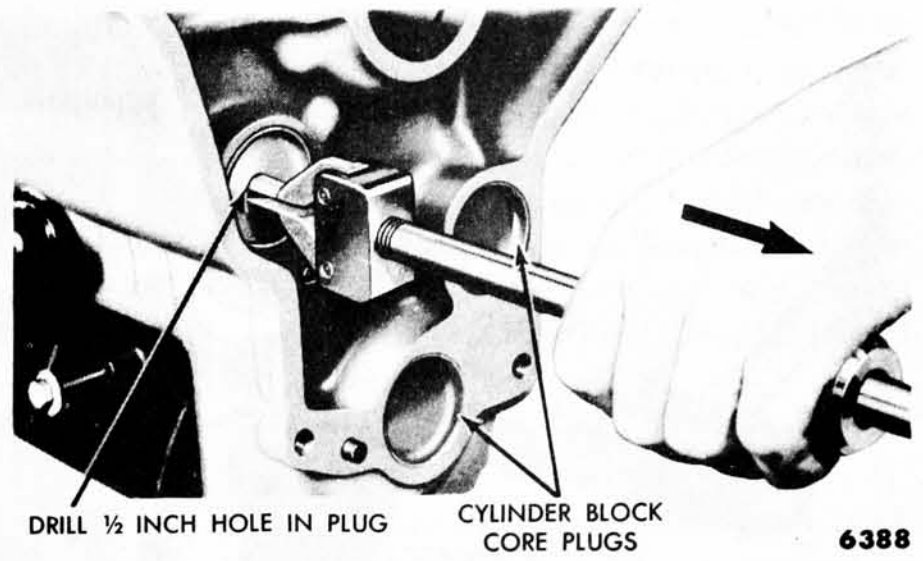

6388

Fig. 19—Camshaft Bore Plug Removal

position it front end up, and pull the tappets away from the camshaft to facilitate camshaft removal. Be sure the oil pan is either drained or removed before inverting engine.

Remove the distributor. Remove the fuel pump. Remove the camshaft sprocket and timing chain. Remove the screws retaining the thrust plate and remove the thrust plate and spacer.

Remove the camshaft carefully to avoid damaging the camshaft bearings with the cam lobes.

(2) **INSTALLATION.** Slide the camshaft carefully into the bearings. Install the thrust plate and spacer. Secure the thrust plate with the retaining screws. Tighten the screws to 12-15 foot-pounds torque. Check the camshaft end play. If the end play is excessive, replace the thrust plate if it is worn. Check the thickness of the spacer if the thrust plate is not at fault. Install the camshaft sprocket, timing chain, front cover, and crankshaft damper. Install the generator belt and adjust belt tension. Release the tappets and install the push rods, then install the rocker arm assembly.

Install the distributor and adjust the initial timing. Install the fuel pump. Install the tappet chamber cover with a new gasket cemented to the cover, and tighten the retaining screws to 15-20 inch-pounds torque. Check the

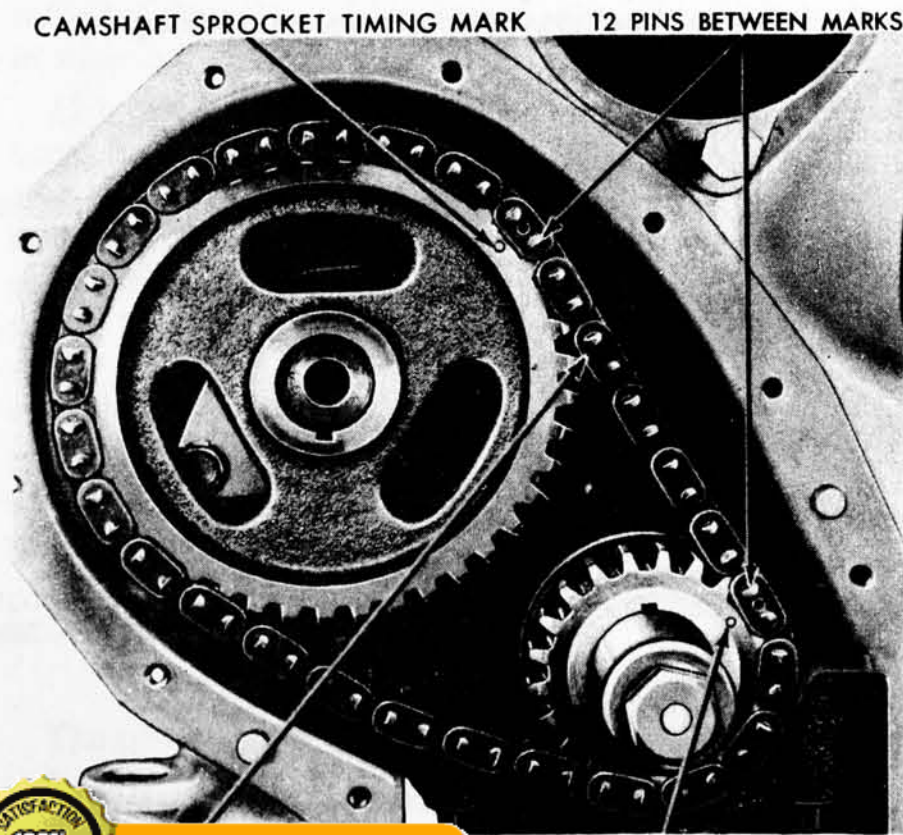

100% SATISFACTION GUARANTEED
BUY IT NOW!
 Click Here To Order

CAMSHAFT SPROCKET TIMING MARK 1244

Timing Marks

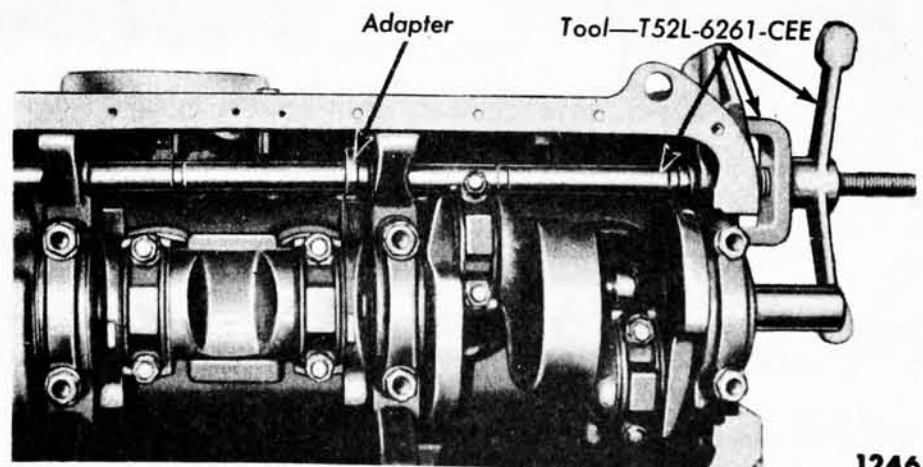

1246

Fig. 20—Camshaft Bearings—Removal or Installation

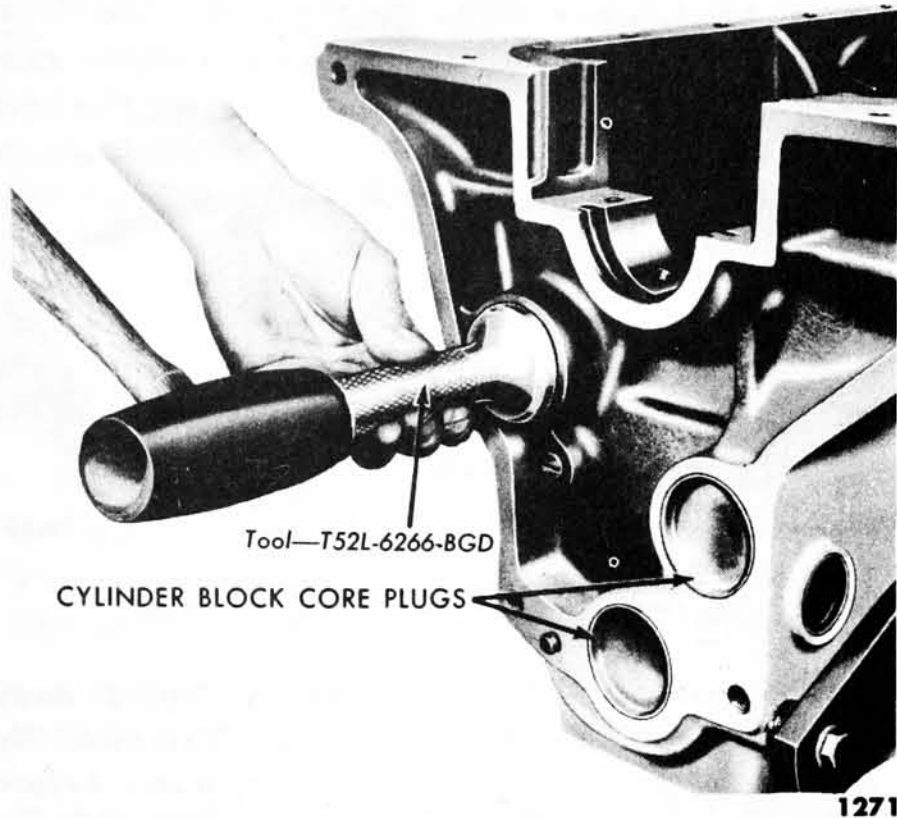

Fig. 21—Camshaft Bore Plug Installation

valve lash (hot). Install the rocker arm cover with a new gasket if necessary, and tighten the nuts to 2.0-2.5 foot-pounds torque. Install the radiator.

c. Camshaft Bearing Replacement.

Replace camshaft bearings if the clearance exceeds 0.005 inch.

It will be necessary to remove the engine from the vehicle to replace camshaft bearings. The bearings are available pre-finished to size for standard and 0.015 inch under-size journal diameters. Number 3 bearing is not interchangeable with the other bearings.

(1) **REMOVAL.** Remove the camshaft. Drill a 1/2 inch hole in the plug at the rear camshaft bearing bore. Use the tool shown in fig. 19 to remove the plug. Remove the camshaft bearings with the tool shown in fig. 20.

(2) **INSTALLATION.** Position the bearing at the bearing bore, and press it in place with the tool shown in fig. 20. No. 1 cam bearing must be pressed in 0.005 - 0.025 inch below the front face of the bearing bore. Press the remaining bearings in sufficiently to align the oil supply holes.

Clean out the plug recess in the camshaft rear bore. Coat the outer rim of a new plug lightly with sealer (8A-19554-A). Install the plug with the tool shown in fig. 21.

Install the camshaft.

7. FLYWHEEL, CRANKSHAFT, AND BEARINGS

The crankshaft and related parts are shown in fig. 22.

a. Flywheel.

Flywheels having a burned or scored surface should be replaced.

(1) **REMOVAL.** Remove the transmission. Remove

the flywheel housing. Mark the clutch assembly so it can be replaced in the same position, and remove the retaining screws. Remove the clutch assembly through the flywheel housing lower opening. Remove the flywheel bolts and pull the flywheel off the crankshaft. Remove the flywheel through the housing lower access opening.

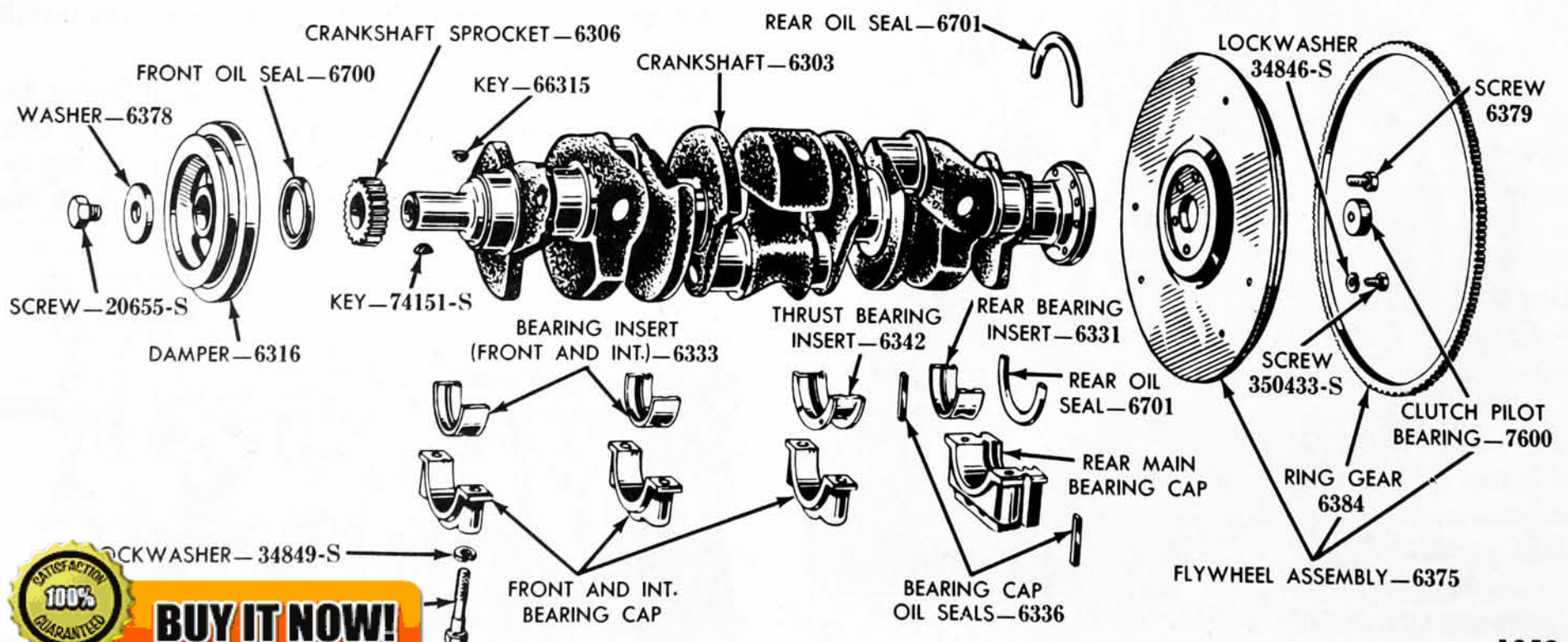

Fig. 22—Crankshaft and Related Parts

BUY IT NOW!
Click Here To Order

PayPal, Discover, MasterCard, VISA

(2) **INSTALLATION.** Position the flywheel on the crankshaft flange, then install the mounting screws. Tighten the screws in sequence across from each other to 75-85 foot-pounds torque. Position the clutch disc and pressure plate on the flywheel, align the clutch disc and install the clutch assembly retaining screws. Install the flywheel housing. Install the transmission.

b. Crankshaft.

The crankshaft is precision-molded, alloy iron with integral counterweights and is statically and dynamically balanced. Oil distribution holes are drilled through the shaft to pressure lubricate the main and connecting rod bearings.

NOTE: *Do not drop the crankshaft when handling. The precision-molded iron shaft, when not supported in bearings, does not have sufficient strength to resist shock loads and may crack when dropped only a short distance.*

(1) **REMOVAL.** Remove the engine and install it on a work stand. Remove the flywheel housing, clutch assembly, starter, and engine rear plate. Mark the clutch pressure plate assembly so it can be reinstalled in the same position on the flywheel. Remove the flywheel. Remove the damper, front cover, camshaft sprocket, and timing chain. Remove the oil pan and the oil pump screen housing assembly.

Make sure all bearing caps are marked so they can be installed in their original locations. Remove all connecting rod bearing caps and bearings. Remove the main bearing caps and bearings. If the same bearings are to be installed, identify all bearings so they can be installed in their original locations. Remove the crankshaft.

(2) **INSTALLATION.** Be sure that all bearing inserts, bores, and the crankshaft journals are clean. Apply a light coat of engine oil to the journals and bearing inserts. Install the inserts in the block. Carefully lower the crankshaft into the bearings. Be careful not to damage the thrust bearing surfaces. Use the Plastigage method to check main bearings. Install the main bearing cap inserts in the caps, and install all the caps in the block except the thrust bearing cap. Tighten the cap bolts to 95-105 foot-pounds torque. Install the thrust bearing cap, then align the thrust bearing using the specified procedure.

Use the Plastigage method to check connecting rod bearings. Install the connecting rods and bearing caps.

Install the engine rear plate. Install the flywheel. Align the clutch disc, compress the clutch pressure plate springs, and install the pressure plate assembly. Install the flywheel housing. Install the starter motor. Install the crankshaft sprocket, the camshaft sprocket, and the timing chain. Install the front cover. Install the damper. Install the engine in the vehicle.

c. Main Bearings.

Steel-backed, copper-lead-insert type bearings are used to support the crankshaft. Use the Plastigage method to check bearing fit.

Crankshaft end play is controlled by the No. 3 main bearing flanges.

If the crankshaft has been removed, the bearing inserts can be easily replaced. However, the inserts can be removed and replaced with the engine in the chassis and without removing the crankshaft, as follows:

Remove the bearing cap, then insert the upper bearing insert removal tool in the oil hole in the crankshaft (fig. 23). When the crankshaft is rotated in the direction opposite to engine rotation, the tool will force out the bearing insert. This tool should be used with caution to avoid damaging the bearing.

To install the upper main bearing insert, place the plain end of the bearing over the shaft on the locking tang side of the shaft. Using the same tool, rotate the crankshaft in the direction of engine rotation until the bearing seats itself.

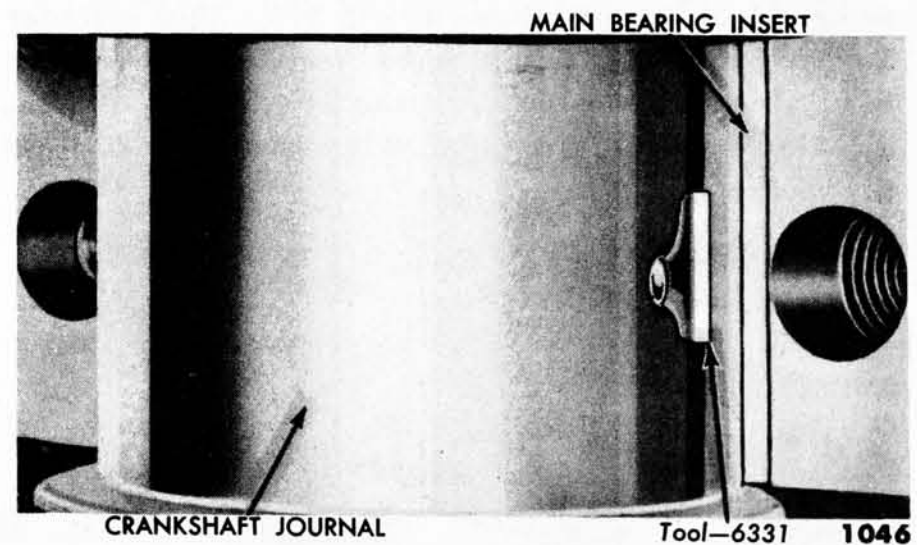

Fig. 23—Main Bearing Insert Removal

8. CONNECTING RODS, PISTONS, PINS, AND RINGS

The piston and connecting rod are shown disassembled 24.



ing Rod Removal.

nder head. Before removing

a piston, remove any ridge at the top of the cylinder bore caused by piston ring wear.

Remove the connecting rod lock nuts and nuts. Pull the cap off the rod, then push the connecting rod and piston out the top of the cylinder.

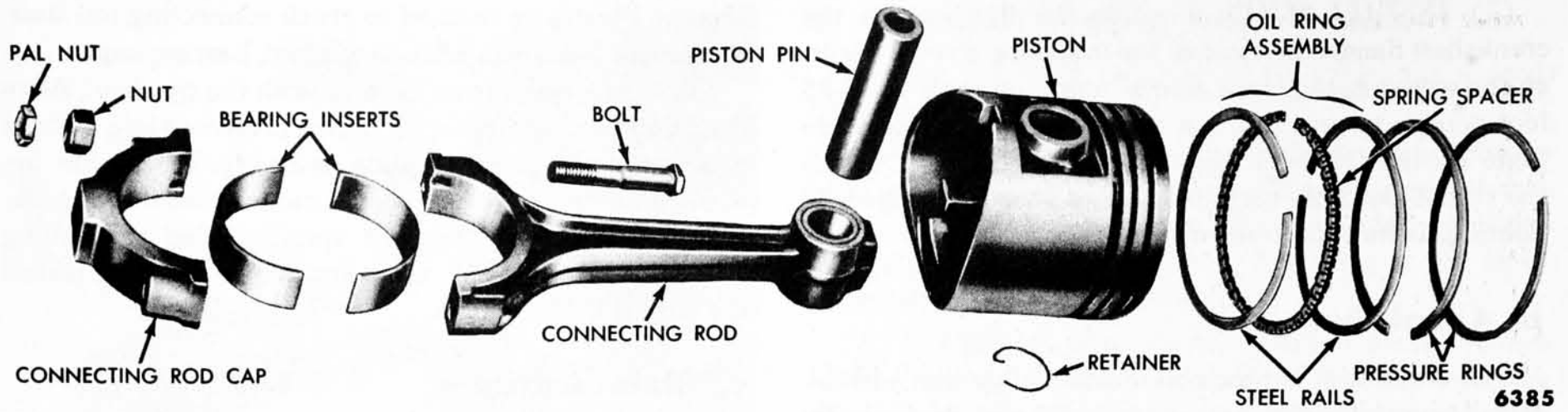

Fig. 24—Piston and Connecting Rod—Disassembled

CAUTION: Do not scratch the crankpin or the cylinder wall when removing the piston and rod.

b. Disassembly.

Mark the pistons for identification of the piston with the bore and rod for assembling purposes.

Remove the piston rings with the tool shown in fig. 25. Remove the piston pin retaining clips, and drive the pin out of the piston and rod (fig. 26).

Remove the bearing inserts after identifying the inserts for reassembly with the same rod and cap if the inserts are to be used again.

NOTE: Each rod and bearing cap is numbered from 1 to 6 from the front to the rear end of the engine. The numbers on the rod and bearing cap must be on the same side when installed in their respective cylinder bores. If a connecting rod is ever transposed from one block or cylinder to another, the bearings must fitted, and the rod must be numbered to correspond with the new cylinder number.



100% SATISFACTION GUARANTEED

BUY IT NOW!

Click Here To Order

ring Rings

PayPal Discover MasterCard VISA

1272

c. Assembly.

Lubricate all parts with light engine oil.

NOTE: Assemble the piston and connecting rod with the oil squirt hole in the rod positioned as shown in fig. 27.

Position the connecting rod in the piston and push the pin into place.

Insert new piston pin retainers by spiraling them into the piston with the fingers. Do not use pliers to install retainers.

Install the oil ring spring spacer in the oil ring groove, position the gap in line with either piston pin boss. Spiral the steel rail ring segment into the upper side of the oil ring groove, position the gap approximately 1 inch to the right side of the spring spacer gap.

NOTE: Firmly support the spring spacer during installation of the steel rails, being sure that the spring

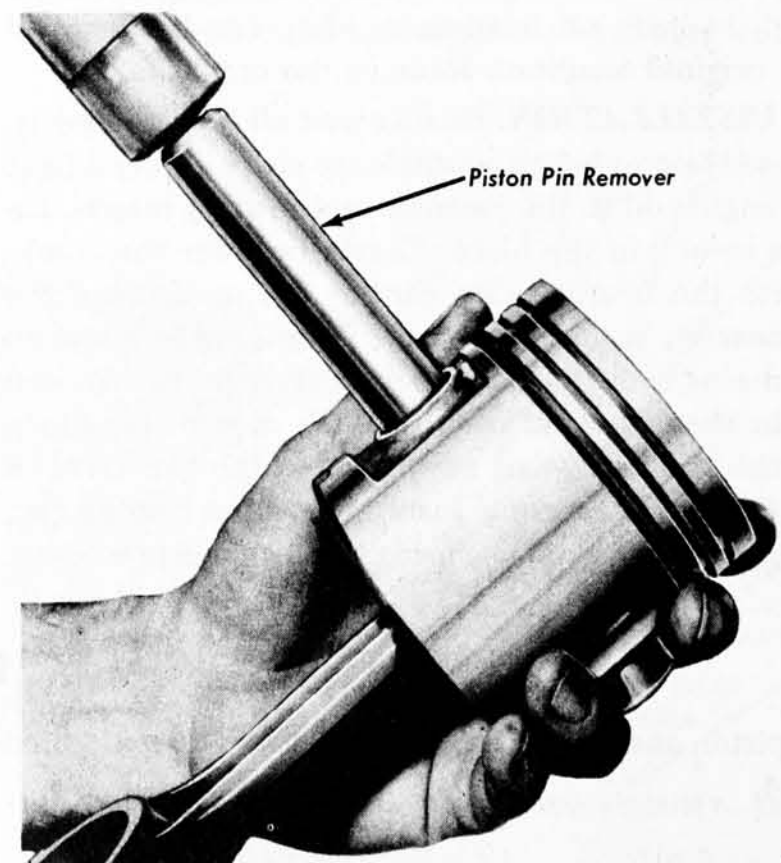

6386

Fig. 26—Piston Pin Removal

spacer ring ends are not overlapped. These ends must be butted together as this permits the spacer to be compressed during installation of the steel rails.

Spiral the remaining steel oil ring segment into position at the lower side of the oil ring groove. Position the gap approximately 1 inch to the left side of the spring spacer gap.

NOTE: *Flex the oil ring assembly in its groove by compressing the ring with the fingers to be sure that the ring segments are free prior to installation in the cylinder bores.*

Install the lower compression ring into its groove with the inside counterbore toward the top of the piston. Position the gap to the spark plug side of the cylinder bore. Install the upper compression ring with the word "TOP" toward the top of the piston. Position the gap to the side or opposite the spark plug side of the cylinder bore.

Install the bearing halves in the rod and cap.

d. Installation.

Check the connecting rod bearing fit using the Plas-

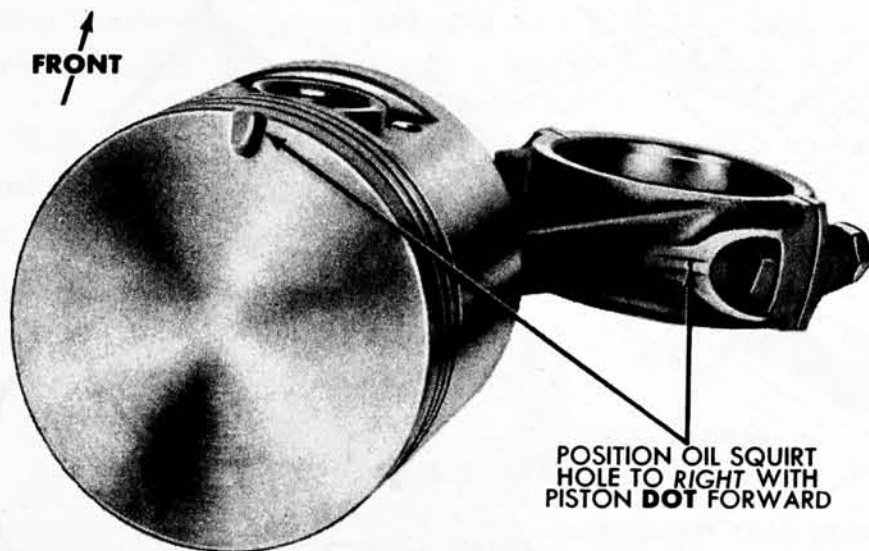

6387

Fig. 27—Correct Position of Oil Squirt Hole

tigage method. Oil the cylinder wall with light engine oil. Make sure the ring gaps are properly spaced around the circumference of the piston. Compress the rings with a compressing tool, and push the piston in with a hammer handle (fig. 28) until it is slightly below the top of the cylinder.

NOTE: *Install the piston with the indentation in the piston head toward the front of the engine.*

Turn the crankshaft throw to the bottom of its stroke. Oil the crankpin and push the piston all the way down until the rod bearing seats on the crankpin. Install the bearing cap (line up the stamped numbers), and tighten the retaining nuts to 45-50 foot-pounds torque. Install new pal nuts, and tighten them to 3-3½ foot-pounds torque (or finger tight plus 1/3 turn).

Install the oil pan and cylinder head. Fill the crankcase with the proper grade and amount of lubricant. Fill the cooling system. Start the engine and run it at idle speed. Make sure there is sufficient oil pressure. Check the temperature to make sure the engine does not overheat.

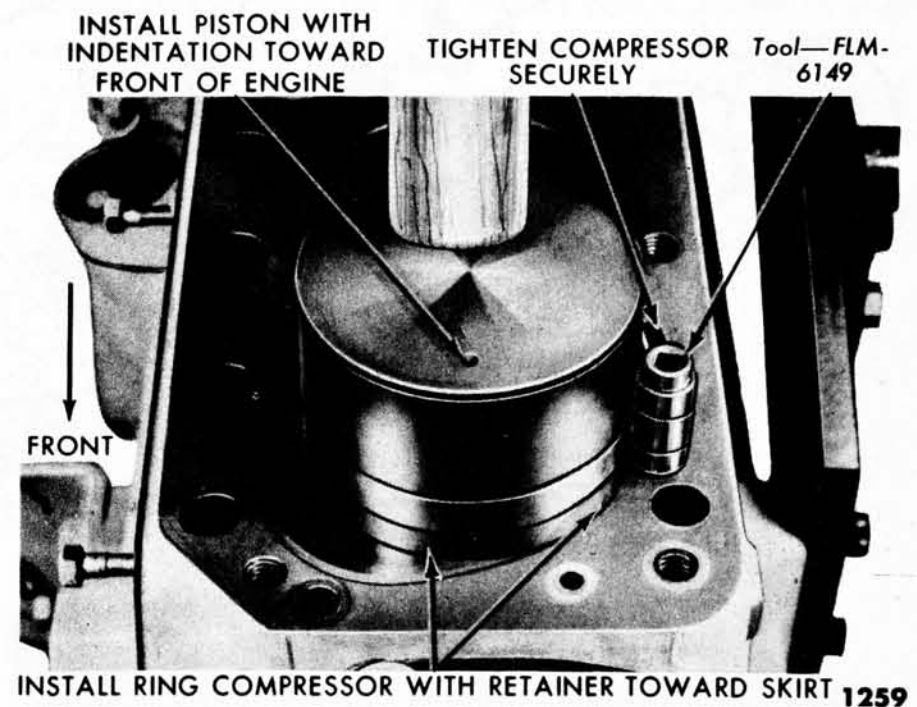

1259

Fig. 28—Piston Installation

9. EXHAUST SYSTEM

The exhaust system on the 6-cylinder car consists of a muffler, an exhaust outlet pipe, and a muffler inlet pipe (fig. 29).

The following procedures cover the replacement of the exhaust system components.

a. Muffler Replacement.

Extra heavy, double-wall construction mufflers are available for service.

(1) **REMOVAL.** Loosen the muffler inlet and outlet pipe clamps. Slide the clamps away from the muffler, on the inlet pipe, and the outlet pipe. Loosen front and rear outlet pipe hangers and disengage the outlet pipe from the muffler by sliding the outlet pipe to the rear. Remove the muffler from the inlet pipe.

(2) **INSTALLATION.** Place the muffler clamps on the



After replacing any part of the exhaust system, always check the frame attaching points in the system and then

inlet and outlet pipes, respectively. Position the muffler on the inlet pipe and slide the outlet pipe into the muffler. Place the inlet pipe and outlet pipe clamps in position on the muffler and tighten the clamps. Tighten the front and rear outlet pipe hangers.

b. Outlet Pipe Replacement.

The outlet pipe is attached to the frame by flexible sound deadening materials which not only prevent the exhaust noises from being conducted through the chassis frame but also relieve the exhaust system from twisting or bending stresses.

(1) **REMOVAL.** Loosen the muffler outlet pipe clamp, leaving the clamp on the muffler. Remove the outlet pipe front and rear support clamps and disengage the outlet pipe from the muffler.

(2) **INSTALLATION.** Position the outlet pipe in the muffler and tighten the clamp. Place the outlet pipe rear support bracket clamp on the outlet pipe. Install the

front support bracket clamp and tighten the nut. Position the rear outlet pipe clamp on the rear bracket and tighten the nut.

c. Inlet Pipe Replacement.

The muffler inlet pipe is designed to give the exhaust gases leaving the exhaust manifolds a direct through passage to the muffler, thereby increasing the over-all efficiency of the exhaust system.

(1) **REMOVAL.** Loosen the muffler inlet pipe clamp. Remove the two nuts holding the inlet pipe to the exhaust manifold, then remove the gasket. Disengage the inlet pipe from the muffler by sliding the inlet pipe forward.

(2) **INSTALLATION.** Place the inlet pipe in the muffler. Install a new gasket on the exhaust outlet flange studs. Slide the inlet pipe flange over the studs and secure the pipe to the exhaust manifold with the two nuts and lockwashers. Tighten the nuts to 23-28 foot-pounds torque. Tighten the muffler inlet pipe clamp.

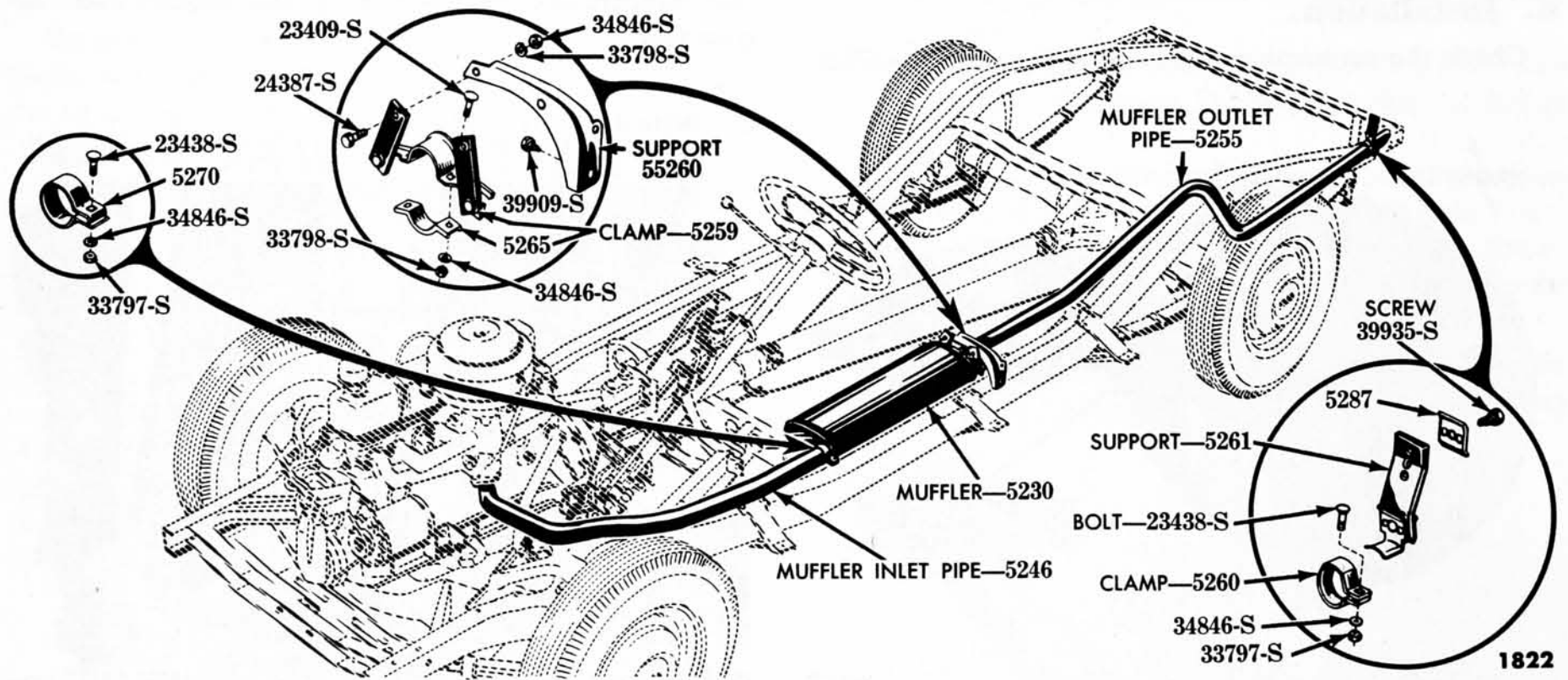

Fig. 29—Exhaust System—6-Cylinder Engine

SERVICE LETTER REFERENCE

| Letter No. | Date | Subject | Changes Information on Page No. |
|------------|------|---------|---------------------------------|
| | | | |
| | | | |
| | | | |
| | | | |
| | | | |
| | | | |

100% SATISFACTION GUARANTEED
BUY IT NOW!
 Click Here To Order

PayPal, American Express, Discover, MasterCard, VISA

Part ONE

POWER PLANT

Chapter III

8-Cylinder 272 (ECG and ECH) and 292 (ECJ and Interceptor) Cubic Inch Engines

| Section | | Page |
|---------|--|------|
| 1 | Manifolds | 42 |
| 2 | Cylinder Heads and Valves | 44 |
| 3 | Oil Pan and Oil Pump and Pressure Relief Valve | 46 |
| 4 | Crankshaft Damper, Pulley, and Cylinder Front Cover | 47 |
| 5 | Timing Chain, Sprockets, Camshaft, Tappets, and Bearings | 48 |
| 6 | Flywheel, Crankshaft, and Bearings | 51 |
| 7 | Connecting Rods, Pistons, Pins, and Rings | 53 |
| 8 | Exhaust System | 55 |

The 8-cylinder, 272 cubic inch engine (fig. 1 and 2) used in the passenger car, has a bore of 3.62 inches and a stroke of 3.30 inches. It has a 7.6:1 compression ratio.

The 8-cylinder, 292 cubic inch engine is used in the police interceptor unit and the ECJ version of the engine is used in the Thunderbird (figs. 3 and 4). Both engine

models have a bore of 3.75 inches and a stroke of 3.30 inches. The police interceptor engine has a 7.6:1 compression ratio. The ECJ engine has an 8.1:1 (Standard or Overdrive) or 8.5:1 (Fordomatic) compression ratio.

Repair and maintenance procedures for these engines are the same unless otherwise noted.



6324

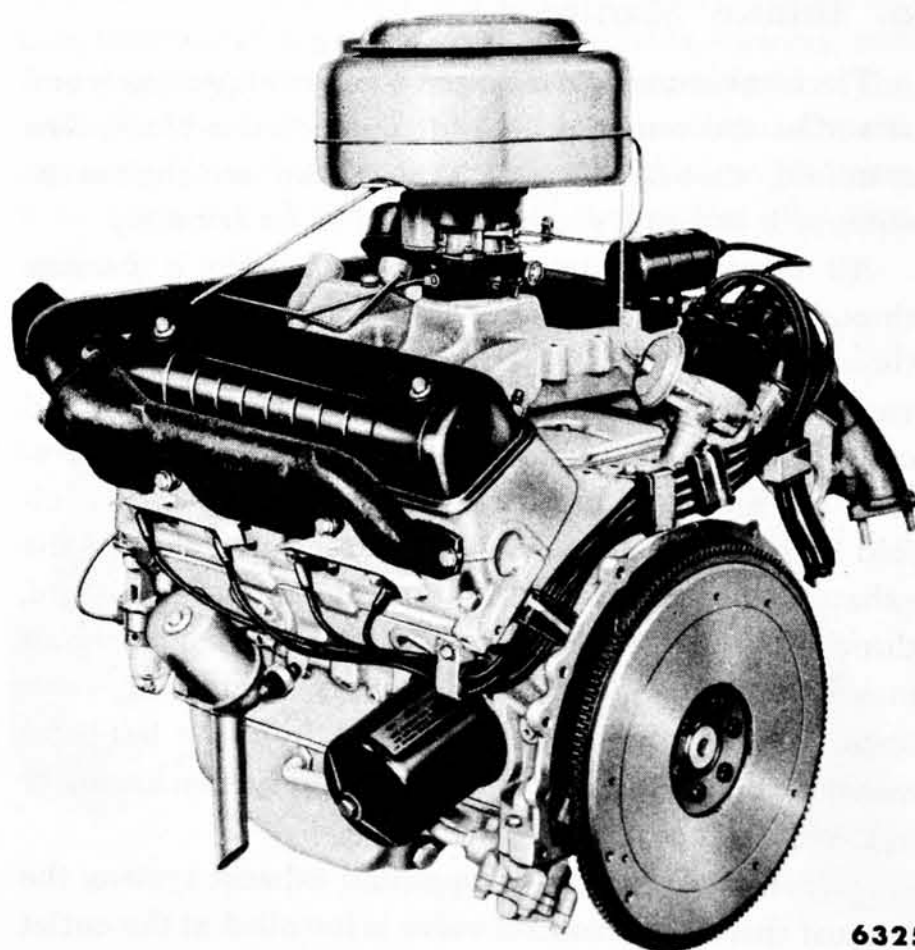

6325

272 Cubic Inch Engine

Fig. 2—³/₄ Rear View—272 Cubic Inch Engine

100% GUARANTEED

BUY IT NOW!

Click Here To Order

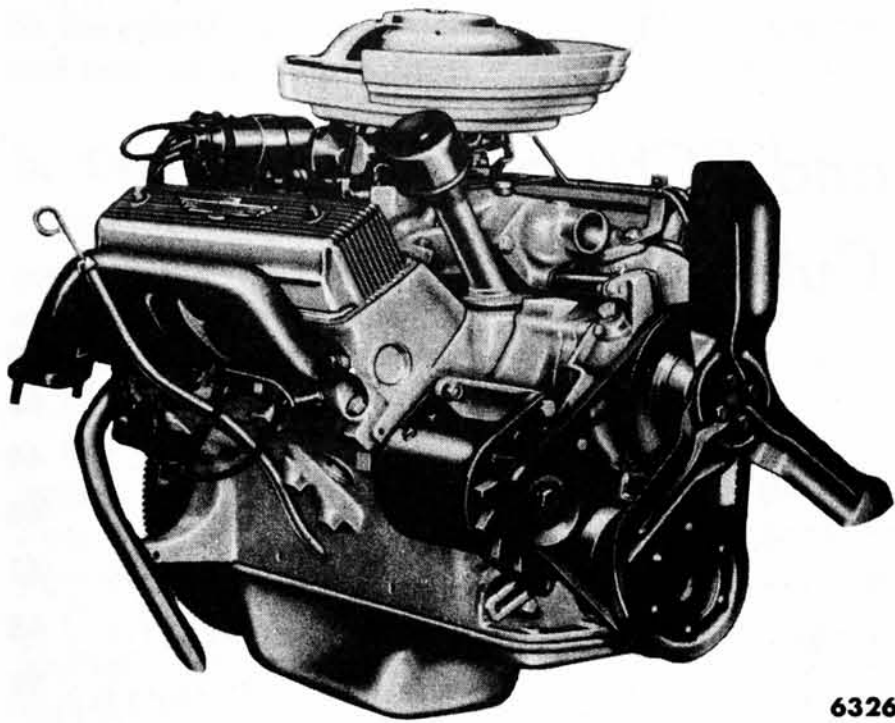

Fig. 3— $\frac{3}{4}$ Front View—292 Cubic Inch (ECJ) Engine

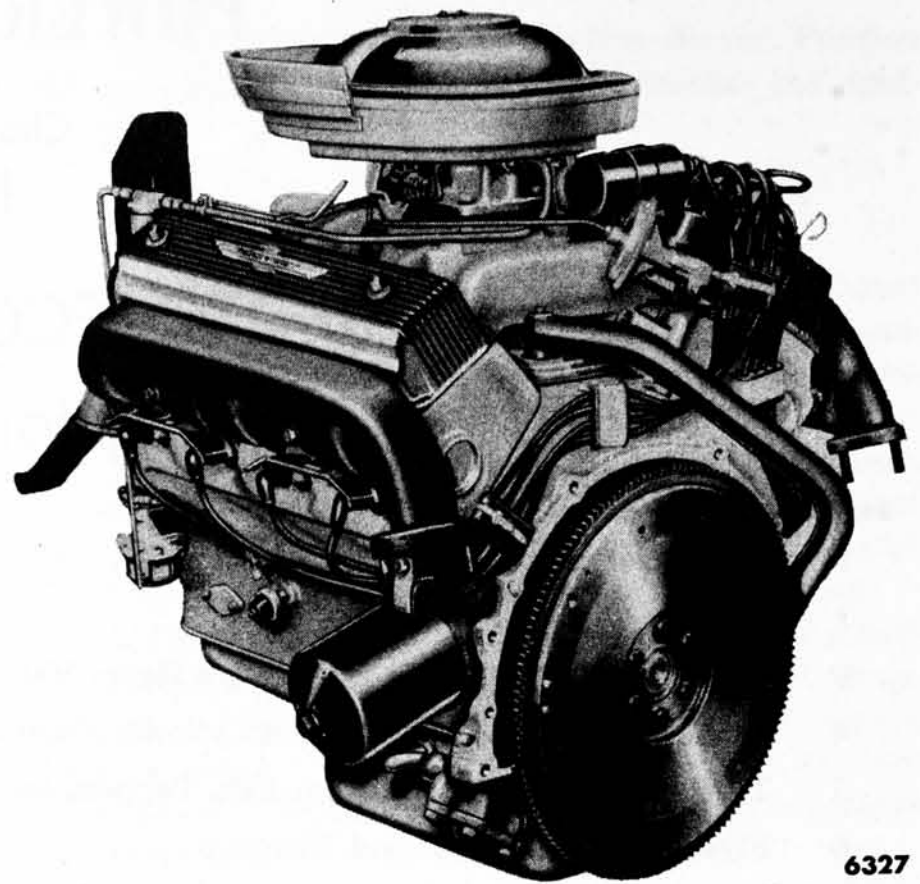

Fig. 4— $\frac{3}{4}$ Rear View—292 Cubic Inch (ECJ) Engine

1. MANIFOLDS

The following replacement procedures may be used for all 272 and 292 cubic inch engines. Follow the procedures carefully as some differences exist between the various engines.

a. Intake Manifold.

The intake manifold is bolted to the cylinder heads and straddles the center portion of the cylinder block. The manifold, carburetor, automatic choke on engines so equipped, and coil, can be removed as an assembly.

All 8-cylinder intake manifolds contain a passage through the center section and under the carburetor, through which hot exhaust gases are directed to assist in vaporizing the incoming fuel charge, thus, stalling and carburetor icing is minimized during cold engine operation. The exhaust gases are diverted into the intake manifold by an exhaust thermostat control valve. Part of the exhaust gases flow from the left-hand exhaust manifold, through the heat riser passage, to the right-hand exhaust manifold, until the thermostatically controlled valve opens, allowing more of the exhaust from the left-hand manifold to flow directly out the exhaust system assembly in the normal manner.

On vehicles equipped with a dual exhaust system, the thermostat control valve is installed at the outlet of the left-hand exhaust manifold. Therefore, the exhaust gases flow through the heat riser pas-

sage, rather than from left to right as in the single exhaust system.

(1) **REMOVAL.** Drain the radiator. Remove the air cleaner (on the two-barrel carburetor, tape the air horn closed).

Disconnect the choke control cable if so equipped.

Disconnect the windshield wiper hose, the vacuum line at the intake manifold, and the fuel line at the fuel pump and at the carburetor. Remove the vacuum lines from the fuel pump, and remove the three lines as an assembly.

Disconnect the distributor vacuum line at the distributor. Disconnect the throttle linkage. Remove the throttle linkage bracket from the intake manifold.

NOTE: *On the Thunderbird, disconnect the throttle pull back spring.*

Disconnect the primary and secondary wires at the coil. Disconnect the heater inlet hose and the heater vacuum control line at the water control valve. Disconnect the upper radiator hose and the water pump by-pass hose.

Remove the manifold retaining bolts, nuts, and four clamps, then remove the manifold (and gaskets), carburetor, and coil as an assembly.

The standard manifold used on the 272 cubic inch engine is shown in fig. 5.

(2) **INSTALLATION.** Using new gaskets, install the

BUY IT NOW!
 Click Here To Order





manifold, coil, and carburetor as an assembly. Align the holes in the manifold gaskets and manifold with the cylinder head tapped holes. Position the manifold clamps, install the manifold retaining bolts and nuts, and tighten them to 23-28 foot-pounds torque, working from the center to the ends.

Connect the upper radiator hose and the water pump by-pass hose. Connect the heater vacuum control line and the heater inlet hose. Connect the primary and secondary coil wires.

NOTE: *On the Thunderbird, connect the throttle pull back spring.*

Install the throttle linkage bracket on the intake manifold. Connect the throttle linkage. Connect the distributor vacuum line.

Install the windshield wiper line, intake vacuum line, and the fuel pump to carburetor line as an assembly. Connect the three lines at the fuel pump. Connect the windshield wiper hose, then connect the vacuum line to the intake manifold and the fuel line at the carburetor.

Connect the choke control cable and remove the tape from the air horn on two-barrel carburetors. Install the air cleaner. Fill the radiator.

b. Exhaust Manifolds.

The exhaust manifolds and crossover pipe for the single exhaust system are shown in fig. 6.

The right-hand exhaust manifold, of the dual exhaust equipped vehicles, is of standard design with a cap over the front opening where the crossover pipe is attached on single exhaust equipped vehicles. The left-hand manifold is of special design to provide an outlet to the separate left-hand exhaust system. The heat control valve is located at the rear of the right-hand exhaust manifold.

NOTE: *Do not remove manifolds when they are hot. They may warp, making assembly difficult, and resulting in leaks.*

(1) **REMOVAL—SINGLE EXHAUST SYSTEM.** Disconnect the crossover pipe from both manifolds. Remove the crossover pipe and the manifold heat control valve. Disconnect the muffler inlet pipe from the right-hand manifold. Remove the bolts, flat washers, spark plug heat shields and manifolds.

(2) **INSTALLATION—SINGLE EXHAUST SYSTEM.** Coat the mating surface of the manifold with a light film of graphite grease. Start the manifold rear bolt into the cylinder head. Hook the manifold on the rear bolt, then install the spark plug heat shields and remaining washers and retaining bolts. Tighten the bolts, working from the center to the ends, to 23-28 foot-pounds torque. Install the heat control valve on the right-hand manifold. Install one on both sides. Install one on the left manifold. Place the cross-

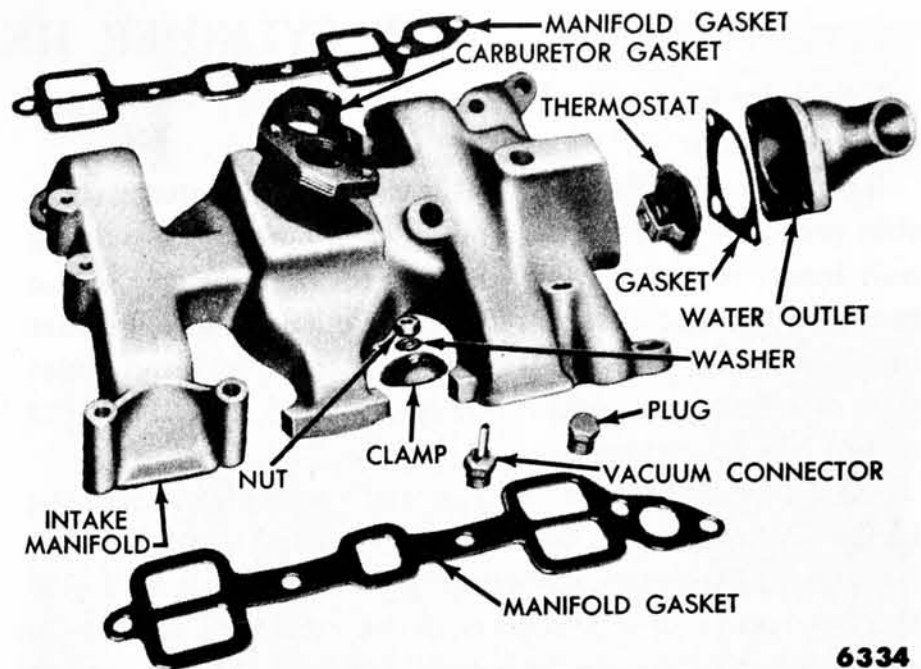

Fig. 5—Standard Intake Manifold—272 Cubic Inch Engine

over pipe on the manifold studs, and install the retaining nuts. Tighten the nuts to 23-28 foot-pounds torque. Install the muffler inlet pipe with a new gasket.

(3) **REMOVAL—DUAL EXHAUST SYSTEM.** The removal procedure for both exhaust manifolds is the same. Disconnect the muffler inlet pipe from the manifold. Remove the bolts, flat washers, spark plug heat shields, and the manifold (and heat control valve on the right-hand manifold).

(4) **INSTALLATION — DUAL EXHAUST SYSTEMS.** Coat the mating surfaces of the manifolds with a light film of graphite grease. Start the manifold rear bolt into the cylinder head. Hook the manifold on the rear bolt, then install the spark plug heat shields, washers, and the remaining bolts. Tighten the bolts, working from the center to the ends, to 23-28 foot-pounds torque. On the right-hand manifold, install the heat control valve, using a new gasket on both sides. Install the muffler inlet pipe with a new gasket.

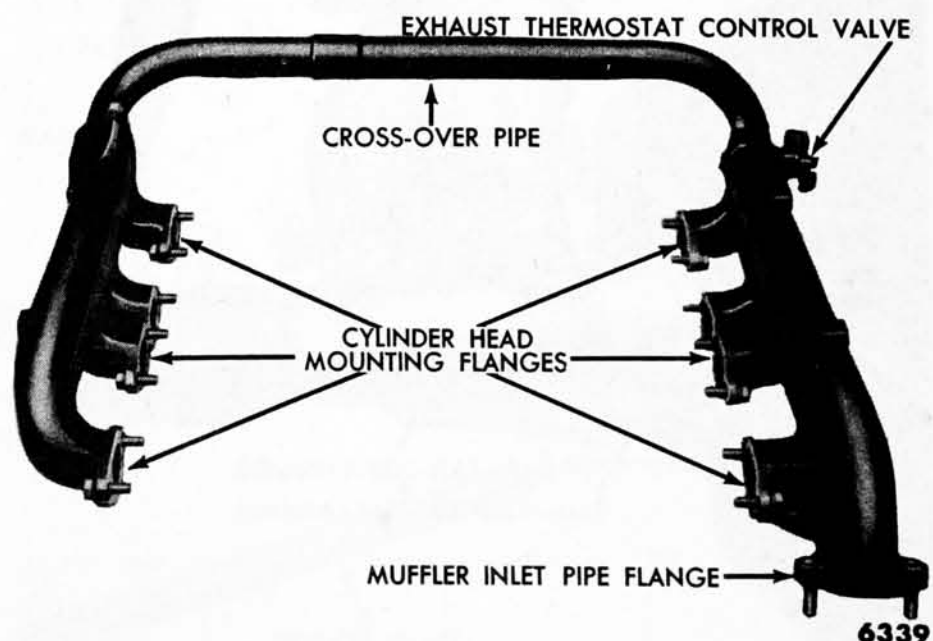

Fig. 6—Exhaust Manifolds and Crossover Pipe—Single Exhaust System

100% SATISFACTION GUARANTEED

BUY IT NOW!

Click Here To Order

PayPal, American Express, Discover, MasterCard, VISA

2. CYLINDER HEADS AND VALVES

The cylinder head contains the valves and the rocker arm mechanism.

The left and right-hand cylinder heads are interchangeable provided a water outlet plug or temperature sending unit insert is removed from one end of the head and a new plug or insert is installed in the other end. Cylinder heads serviced to the field will not have the water outlet plug or insert installed so they can be used for either right or left-hand installations.

The plug is installed in the rear water outlet opening of the right-hand cylinder head by using the tool shown in fig. 7. The temperature sending unit insert is installed in the left-hand cylinder head with the same tool. Be sure to apply a light coat of water resistant sealer to the sealing surface of the plug or insert before installation.

The intake and exhaust valves are the rotating type and incorporate umbrella-type valve stem seals (fig. 8).

a. Cylinder Head Removal.

Drain the cooling system. Clean the outside of the valve chamber cover. Remove the cover. Remove the exhaust manifold. Remove the spark plugs. Remove the intake manifold. Remove the ignition harness bracket from the right-hand cylinder head.

Remove the distributor cap when removing the right-hand head from the Thunderbird.

When removing the right-hand head from all other vehicles, disconnect the battery ground cable, and the oil dipstick tube bracket from the cylinder head. Remove the generator bracket to cylinder head bolt, remove the generator front mounting bolt, and move the generator out of the way.

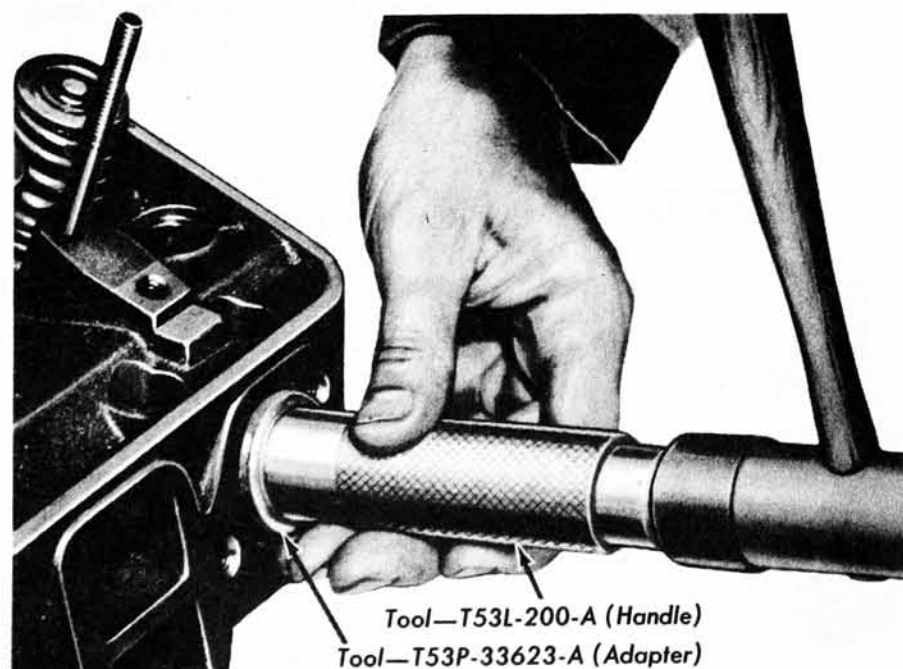

6065

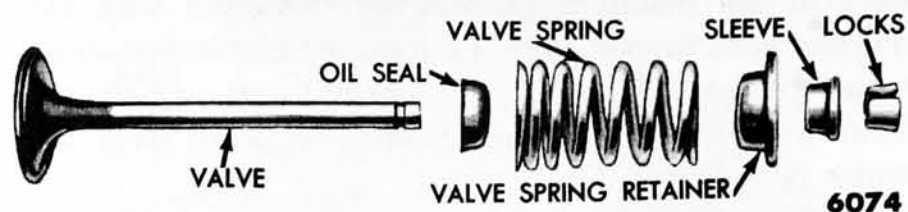

6074

Fig. 8—Valve Assembly

Release the spring tension on the rocker arms by loosening the adjusting screws, then remove the rocker arm assembly and oil baffle plates. Remove the valve push rods in sequence. Identify the push rods so they can be replaced in their original positions. Disconnect the wire from the temperature sending unit (left-hand head).

Remove the cylinder head bolts. Install the cylinder head holding fixtures.

NOTE: *The distributor location on the Thunderbird will not permit the installation of the rear holding fixture on the right-hand head in its normal position. Install the fixture one hole forward.*

Lift the cylinder head off the block. Do not pry between the head and block. Remove the head gasket. The head is shown mounted in the holding fixtures in fig. 9.

b. Cylinder Head Disassembly.

Remove the cotter pins at each end of the rocker arm shaft, then remove the flat washers, spring washers, and plugs. Slide the rocker arms, springs, and brackets off the shaft. Be sure to identify the parts so they can be installed in their original positions. The rocker arm mechanism is shown disassembled in fig. 10.

Clean the carbon out of the cylinder head combustion chamber. Compress the valve springs with the tool shown in fig. 11, then remove the valve stem locks, and sleeve.

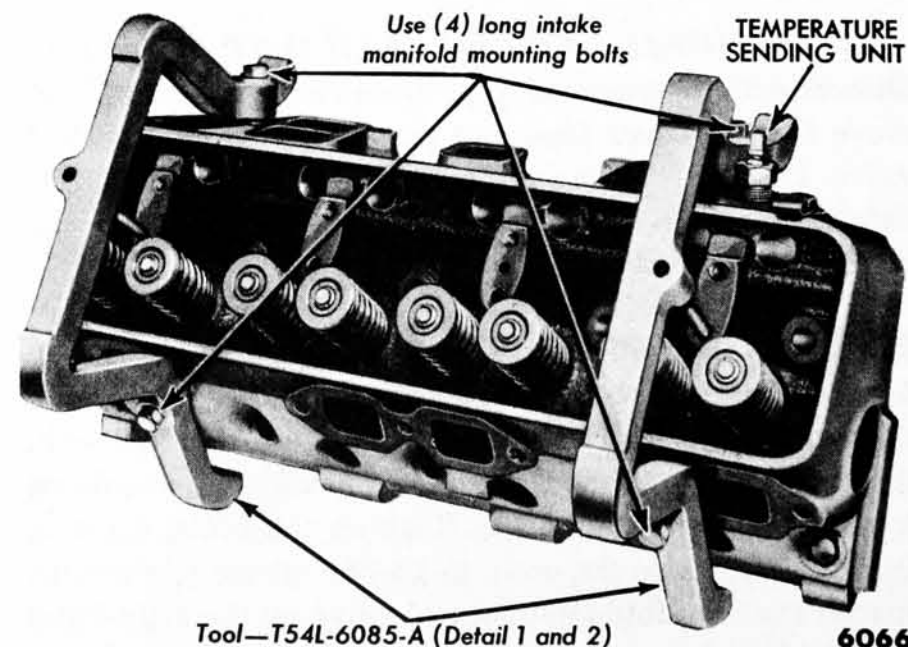

6066

Fig. 9—Cylinder Head Holding Fixture—Typical

100% SATISFACTION GUARANTEED

BUY IT NOW!

[Click Here To Order](#)

Outlet Plug Installation

PayPal, American Express, Discover, MasterCard, VISA

Release the spring compression and remove the tool. Remove the valve spring retainer, valve spring, and the valve stem seal. Remove the valve.

c. Cylinder Head Assembly.

Oil all moving parts with engine oil. Be sure the oil plugs are installed in each end of the rocker shaft. The plug should be installed cup side out. The plug is an interference fit in the shaft; however, do not peen the plug. Install a flat washer, spring washer, another flat washer, and a cotter pin in one end of the rocker shaft. Install the parts in the order shown in fig. 10.

After grinding valves or installing new valves and grinding seats it is good practice to lightly lap in the valves with a medium grade lapping compound to match the seat.

Install each valve in the port from which it was removed or to which it was fitted. Install a new valve stem seal. Install the valve spring with the tightly wound coil against the head. Install the spring retainer. Using the tool illustrated in fig. 11, compress the spring and spring retainer, then install the sleeve and the locks.

d. Cylinder Head Installation.

Using a new gasket with sealer applied to both sides, position the cylinder head on the engine. Remove the holding fixture brackets. Install the cylinder head bolts, and tighten them to 55 foot-pounds torque (cold) in the proper sequence (fig. 12). Repeat the operation, tightening the bolts to 65 foot-pounds torque (cold).

NOTE: *The proper wrench to use for each bolt is indicated in fig. 12. When using the socket and extension on a Fordomatic equipped vehicle, work from the top of the manifold, and force the socket extension past the Fordomatic oil level indicator tube in order to get the socket on the bolt head.*

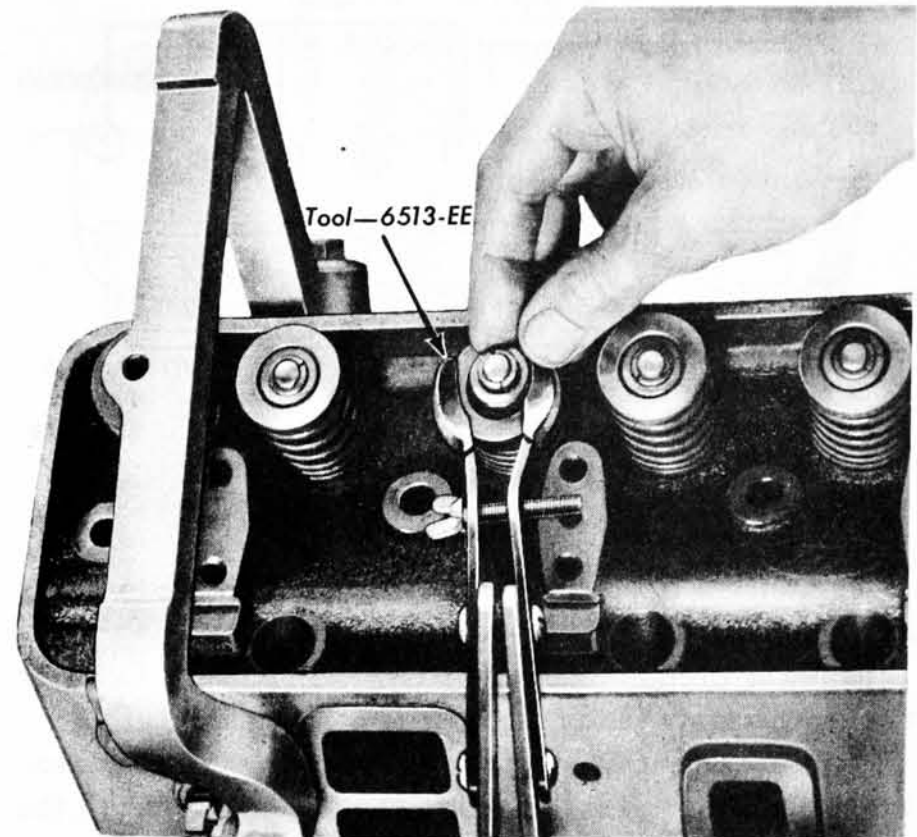

6370

Fig. 11—Removing or Installing Valve Locks

Install the push rods in their proper locations. Position the oil baffle plates on the head. Place the rocker assembly on the plates, then install the bracket retaining screws and nuts. Be sure to install the oil drain tube on the same end bracket from which it was removed. The bracket end of the tube must enter the locating hole in the rocker shaft.

CAUTION: *Be sure the rocker shaft support brackets are not upside down when the assembly is installed. There is a 0.020 inch difference in bracket height when reversed. Tightening the screws with the brackets reversed can result in a broken rocker shaft.*

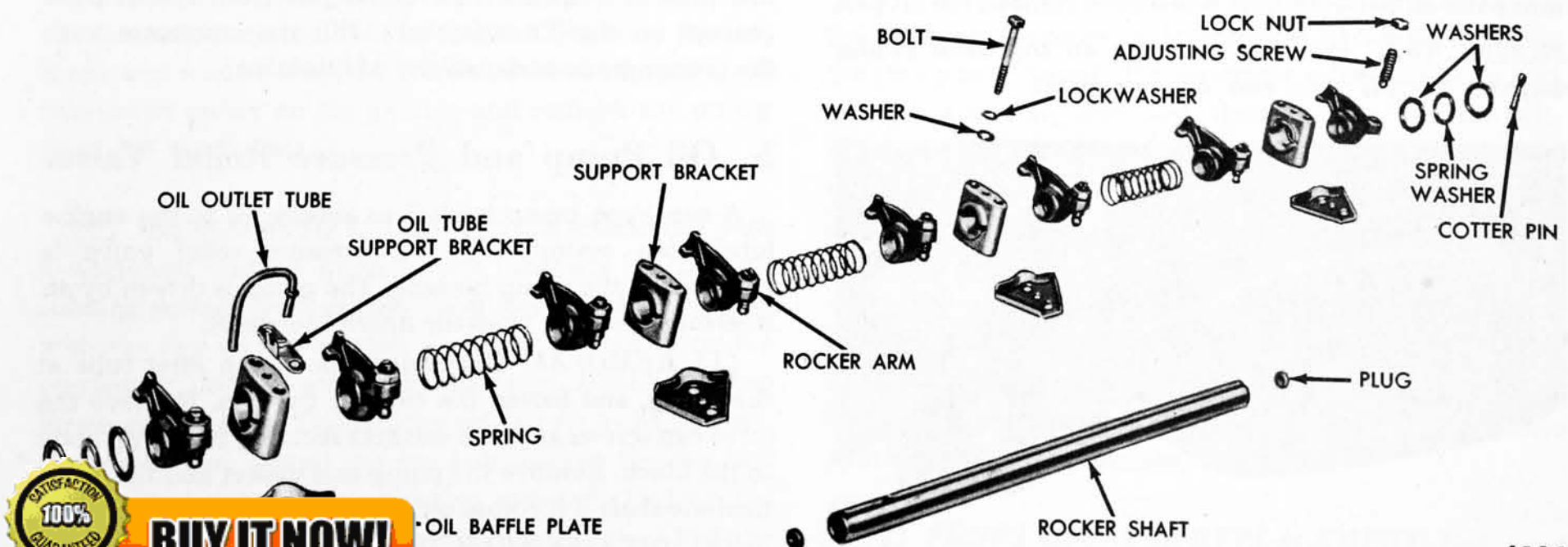

6184

Fig. 10—Rocker Arm Mechanism—Disassembled

100% SATISFACTION GUARANTEED

BUY IT NOW!

[Click Here To Order](#)

PayPal American Express Discover MasterCard VISA

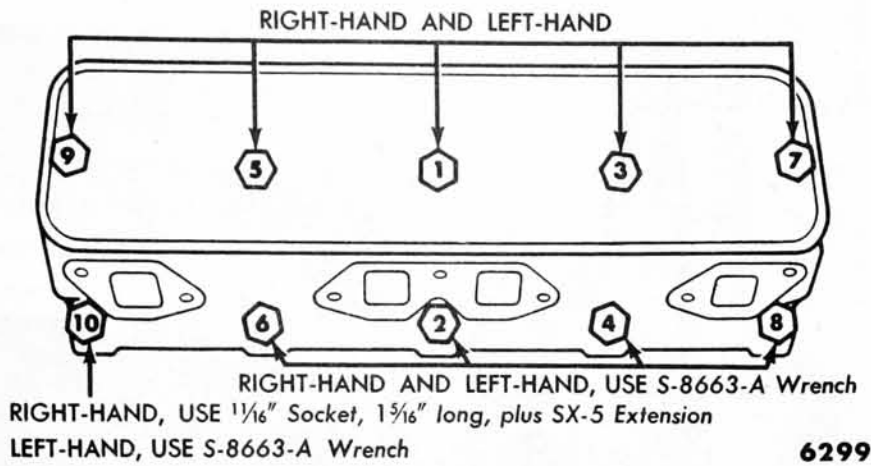

Fig. 12—Cylinder Head Bolt Tightening Sequence

Tighten the bracket retaining screws and nuts to 12-15 foot-pounds torque.

Make a preliminary valve lash adjustment. Connect the temperature sending unit wire (left-hand head).

After installing the right-hand head on all vehicles except the Thunderbird, position the generator, install the

generator front mounting bolt, then fasten the generator bracket to the cylinder head. Connect the battery ground cable and the dipstick bracket.

After installing the right-hand head on the Thunderbird, install the distributor cap.

Install the ignition harness bracket on the right-hand cylinder head. Install the intake manifold. Install the spark plugs, then install the heat shields and the exhaust manifold.

Fill the cooling system and run the engine until it has reached normal operating temperature. Tighten the head bolts to 75 foot-pounds torque (hot). Check the valve lash and adjust the lash if necessary. Cement a new gasket on the rocker arm cover if necessary, then install the cover. Tighten the cover nuts to 2.0-2.5 foot-pounds torque.

NOTE: *After the cylinder head bolts have been tightened to specifications, no additional tightening is necessary and the bolts should not be disturbed.*

3. OIL PAN AND OIL PUMP AND PRESSURE RELIEF VALVE

The oil pump is externally mounted on the lower left-hand corner of the engine, and is driven by an intermediate shaft which fits in the distributor drive shaft. The pump uses a one piece tube to pick up the oil from the oil pan (fig. 13). The oil inlet screen and cover assembly is attached to the oil pan by a nut.

a. Oil Pan.

The oil pan is sealed to the cylinder block and front cylinder cover by a one-piece cork gasket, and the pan is retained by 18 cap screws, 2 nuts on studs at the rear, and 2 nuts and bolts at the front.

(1) **REMOVAL.** Drain the crankcase. Remove the engine front splash pans (except on the Thunderbird). Disconnect the oil pump inlet tube at the oil pump. Remove the oil pan retaining screws and remove the oil pan.

NOTE: *No. 1 cylinder must be on top dead center before the oil pan can be removed.*

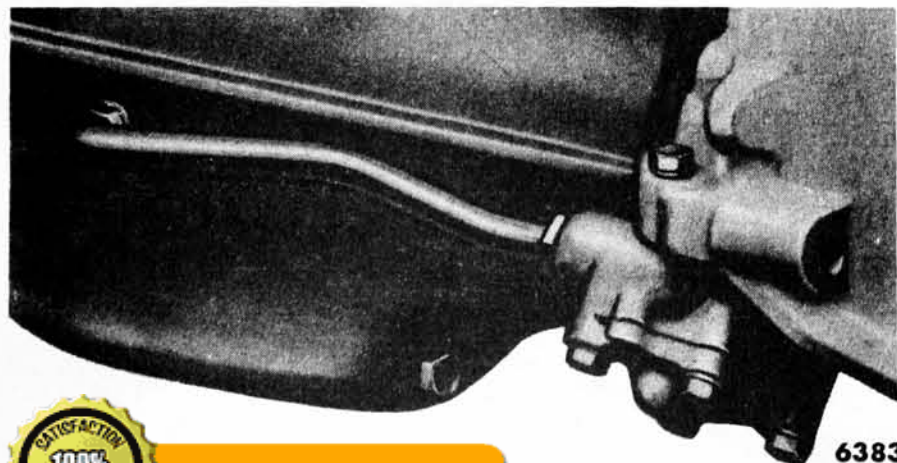

Remove the nut securing the oil pump inlet tube to the oil pan, then remove the oil pump screen and inlet tube assembly from the oil pan.

(2) **INSTALLATION.** Coat the screen assembly retaining nut with oil resistant sealer, install the copper washer on the tube, then install the oil pump screen and inlet tube assembly in the oil pan. Tighten the retaining nut to 10-12 foot-pounds torque. Coat both sides of a new pan gasket with sealer. Position the gasket on the oil pan, hold the pan in place against the block, and install two of the retaining screws on each side of the pan. Install the remaining screws, and tighten the screws, from the center to the ends, to 12-15 foot-pounds torque.

Using a new seal, connect the oil pump inlet tube to the pump. Tighten the oil tube to oil pump nut to 10-12 foot-pounds torque. Install the engine front splash pans (except on the Thunderbird). Fill the crankcase with the proper grade and quantity of lubricant.

b. Oil Pump and Pressure Relief Valve.

A gear-type pump is used to supply oil to the engine lubrication system. The oil pressure relief valve is mounted in the pump housing. The pump is driven by an intermediate shaft from the distributor shaft.

(1) **REMOVAL.** Disconnect the pump inlet tube at the pump, and loosen the tube at the pan. Remove the three cap screws and lock washers securing the pump body to the block. Remove the pump and gasket and the intermediate shaft if it comes out with the pump.

(2) **DISASSEMBLY.** Remove the four cap screws retaining the pump cover to the pump body. Remove the



BUY IT NOW!

Click Here To Order

Oil Pump and Inlet Tube—
for Engine



cover plate and gasket. Do not tap the pump drive shaft to drive the cover off the pump body. Remove the oil pump gear and shaft assembly and oil pump idler gear. Remove the oil pressure relief plug, gasket, spring, and plunger. A disassembled view of the oil pump is shown in fig. 14.

(3) **ASSEMBLY.** Oil all parts thoroughly. Install the oil pressure relief valve plunger, spring and cover plug, and gasket. Install the idler gear and the oil pump gear and shaft assembly. Install the cover plate with a new gasket, and tighten the cover plate screws to 12-15 foot-pounds torque. Check the oil pump shaft end play with a dial indicator or Plastigage (0.0015-0.0055 inch).

(4) **INSTALLATION.** Insert the oil pump intermediate shaft in the oil pump shaft. Note the position of the distributor shaft, and set the oil pump shaft so the intermediate shaft will engage the distributor shaft. Coat both sides of a new gasket with sealer, position the pump housing and gasket on the block, install the three retaining screws, and tighten them to 12-15 foot-pounds torque.

CAUTION: *Do not attempt to force the pump in position if it will not seat against the block. The intermedi-*

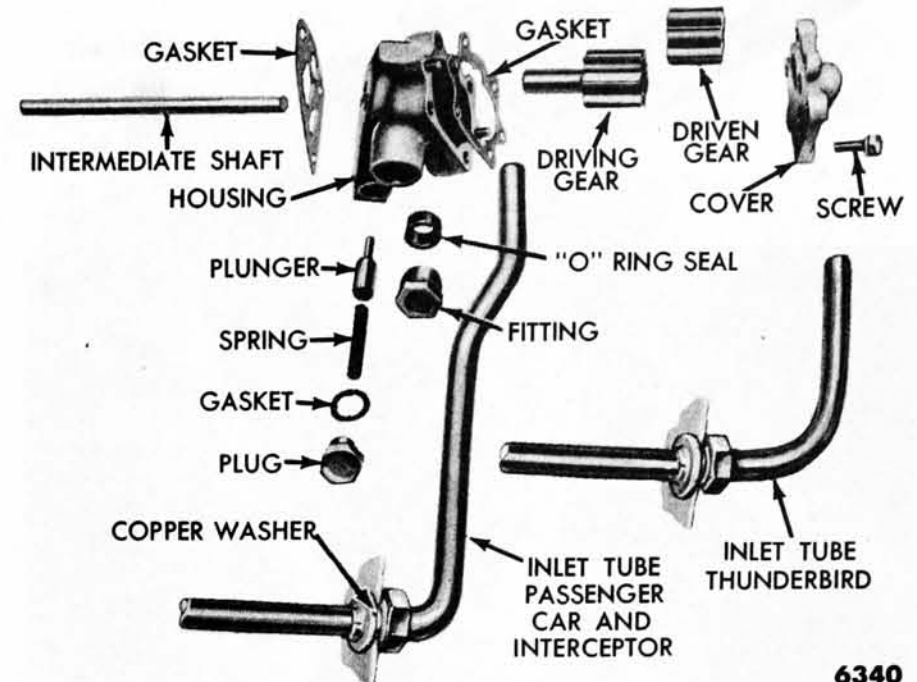

Fig. 14—Oil Pump

ate shaft may be out of alignment with the seat in the distributor shaft. Align the seat and shaft if necessary.

Install the oil pump inlet tube and a new seal in the pump. Tighten the oil tube to oil pump nut and the oil tube to oil pan nut to 10-12 foot-pounds torque.

4. CRANKSHAFT DAMPER, PULLEY, AND CYLINDER FRONT COVER

a. Crankshaft Damper and Pulley.

The damper and pulley assembly is pressed on, and keyed to, the front of the crankshaft and is retained by a cap screw and washer.

(1) **REMOVAL.** Drain the cooling system. Remove the radiator. Loosen the generator mounting bolts and fan belt adjusting arm bolt. Pivot the generator to loosen the fan belt, then remove the fan belt. Remove the cap screw and washer from the crankshaft. Install a standard two-jawed puller on the pulley, and remove the pulley from the crankshaft.

(2) **INSTALLATION.** Lubricate the crankshaft with a whitelead and oil mixture and lubricate the oil seal rubbing surface with grease. Line up the pulley keyway with the key on the crankshaft. Drive the pulley on the crankshaft using a soft metal hammer. Install the cap screw and washer. Tighten the cap screw to 85-95 foot-pounds torque. Install the fan belt. Adjust the fan belt

b. Cylinder Front Cover.

The cylinder front cover is a one piece casting which contains the crankshaft front oil seal. The water pump and fuel pump are mounted on the front cover. The front cover retaining screws also retain the engine front steady rest (front support on Thunderbirds).

(1) **REMOVAL.** Drain the cooling system. Remove the radiator. Remove the fan blades and hub. Remove the fuel pump. Loosen the generator mounting bolts and fan belt adjusting arm bolt, then remove the fan belt. Remove the generator mounting bracket bolts at the engine front cover, and move the bracket out of the way. Loosen the generator adjusting bracket and move it out of the way. Remove the crankshaft pulley. Remove the engine front steady rest. Remove the four bolts that fasten the oil pan to the cylinder front cover. Disconnect the water bypass tube. Remove the seven remaining front cover bolts, then remove the water pump and cylinder front cover as an assembly.

(2) **FRONT OIL SEAL REPLACEMENT.** Drive out the old seal with a pin punch. Clean the seal recess thor-



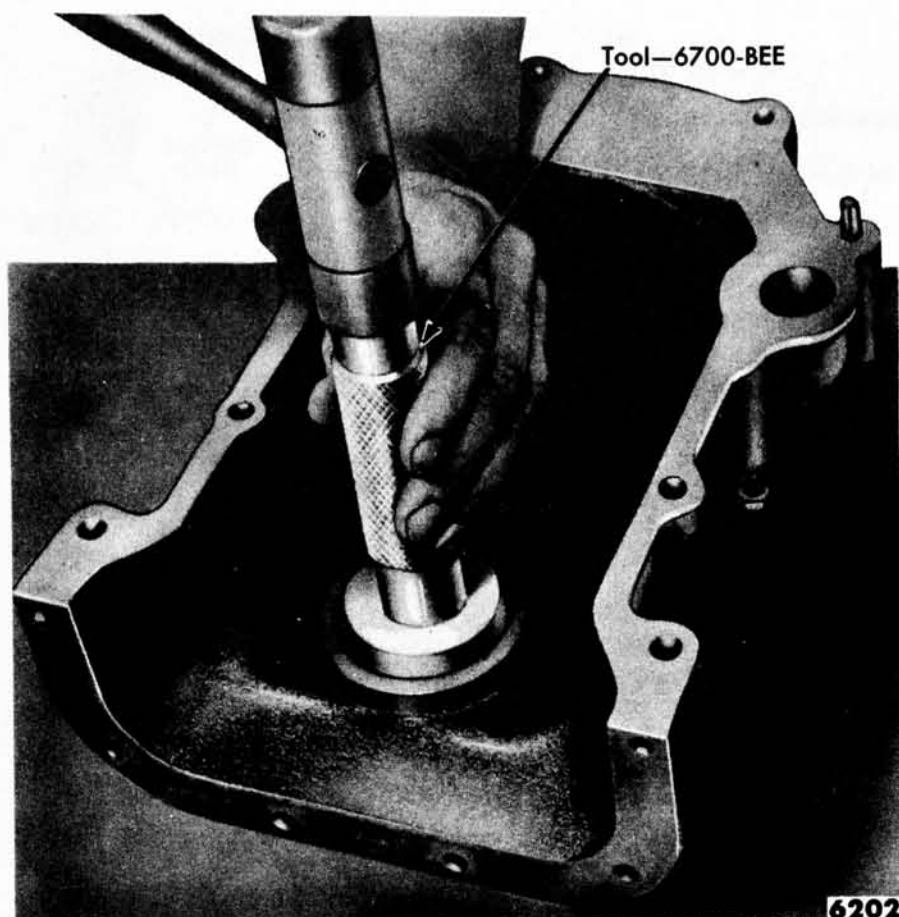

Fig. 15—Oil Seal Installation—Typical

oughly. Coat the recess with sealer, and install a new seal with the tool shown in fig. 15. Drive the seal into the recess until it bottoms. Check the seal spring after the seal has been installed to be sure it is properly positioned in the seal.

(3) **INSTALLATION.** Clean the cylinder front cover. Apply a light film of grease to the rubbing surface of the crankshaft oil seal. Coat both sides of the cover gasket with sealer and position it on the block. Position the front cover assembly on the block, and align it with the tool shown in fig. 16 to make sure the oil seal will be in proper

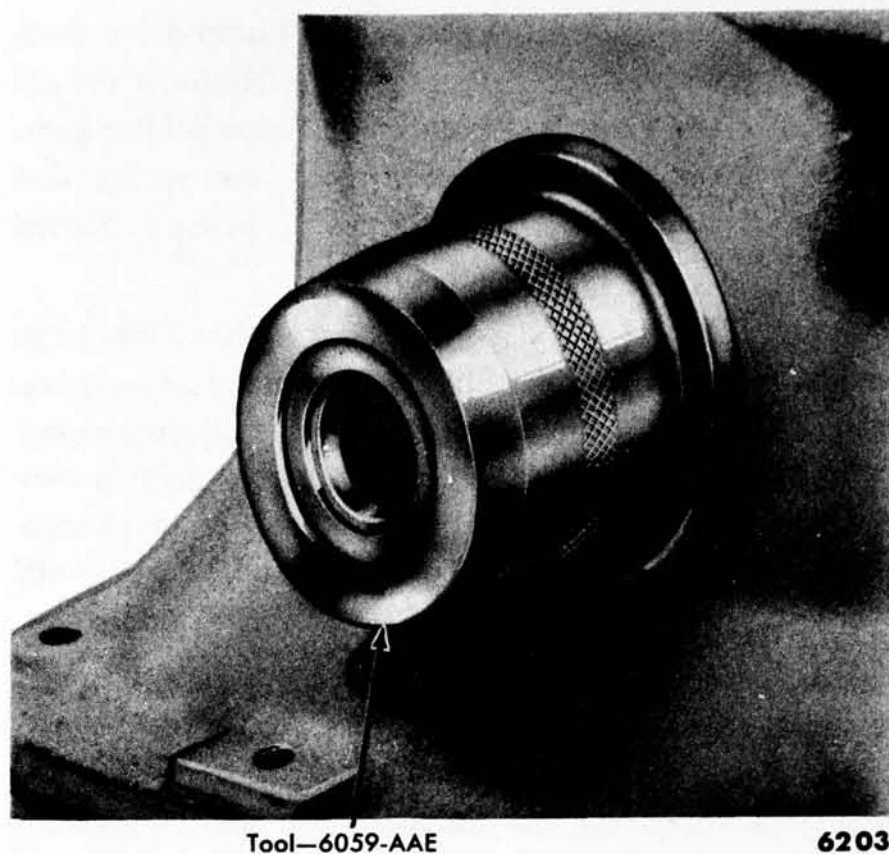

Fig. 16—Front Cover Alignment—Typical

alignment with the crankshaft. Install the bolts at the front of the oil pan. Coat the cover bolt threads with sealer. Install the bolts, making sure the engine front steady rest (support on Thunderbirds) and generator support bracket are installed. Tighten the $\frac{3}{8}$ inch bolts to 23-28 foot-pounds torque and the $\frac{5}{16}$ inch bolts to 12-15 foot-pounds torque.

Install the water by-pass tube. Install the crankshaft pulley. Using a new gasket, install the fuel pump. Install the fan blades and hub. Install and adjust the fan belt. Install the radiator, then fill the cooling system. Run the engine until normal operating temperature has been reached, then check for coolant and oil leaks.

5. TIMING CHAIN, SPROCKETS, CAMSHAFT, TAPPETS, AND BEARINGS

The camshaft is driven by means of a timing chain which connects the camshaft sprocket to the crankshaft sprocket (fig. 17).

a. Camshaft Sprocket, Fuel Pump Eccentric, and Timing Chain.

The camshaft sprocket is a slip fit on, and is keyed to, the end of the camshaft. The camshaft sprocket, fuel pump eccentric counterweight, eccentric, spacing washer, and lockwasher are retained on the camshaft by

water pump, and fan as a unit. Crank the engine until the timing marks on the sprockets are positioned as shown in fig. 18.

Remove the fuel pump eccentric and camshaft sprocket cap screw. Remove the fuel pump eccentric and counterweight from the camshaft. Slide both sprockets and the timing chain forward, and remove the camshaft sprocket and chain as an assembly.

(2) **INSTALLATION.** Position the camshaft sprocket and timing chain on the camshaft. Be sure the timing marks on the camshaft sprocket and the crankshaft sprocket are positioned as shown in fig. 18, and there

100% SATISFACTION GUARANTEED

BUY IT NOW!

Click Here To Order

the cylinder front cover,

PayPal American Express Cards Discover Network MasterCard VISA

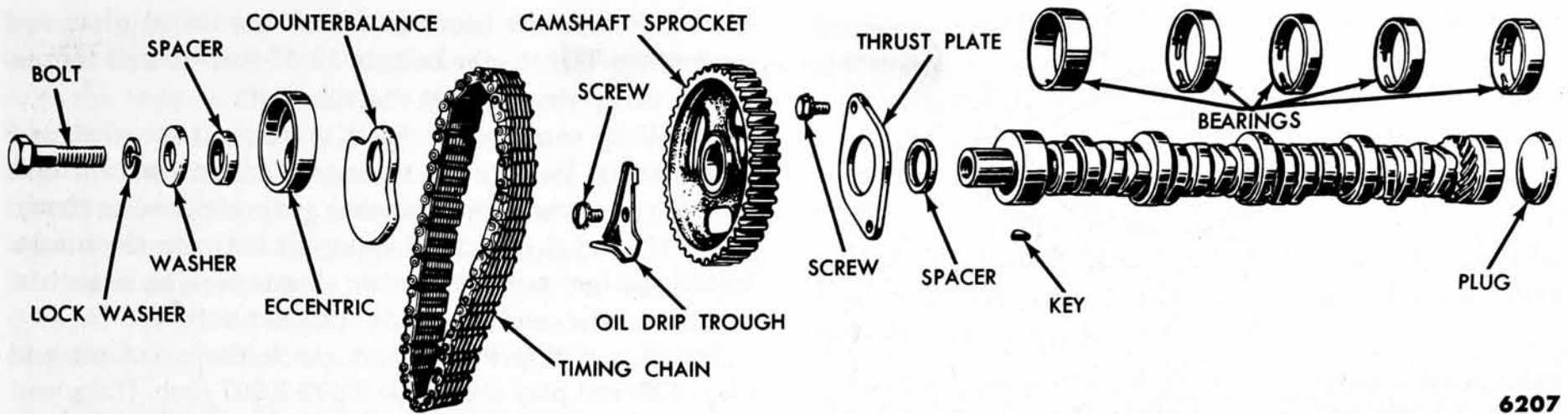

6207

Fig. 17—Camshaft and Related Parts

are 12 timing chain link pins between the marks. Install the fuel pump eccentric counterweight, eccentric, and spacing washer on the camshaft. Install the sprocket cap screw, and tighten the screw to 35-45 foot-pounds torque.

Install a new oil seal in the cylinder front cover, then install the cover. Install the fuel pump, crankshaft pulley, fan, and radiator. Fill the cooling system. Check and adjust the ignition timing.

b. Camshaft.

The camshaft is supported by five steel-backed babbit, insert-type, bearings in the cylinder block. End thrust of the camshaft is controlled by a thrust plate mounted on the cylinder block at the forward end of the camshaft (fig. 19).

(1) **REMOVAL.** Remove the radiator, radiator grille,

crankshaft pulley, fuel pump, water pump and fan blade assembly, and the cylinder front cover.

Remove the intake manifold, carburetor, and coil as an assembly. Remove the rocker arm covers, then remove both rocker arm assemblies. Remove the push rods. Remove the valve push rod chamber cover.

Crank the engine until the timing marks on the camshaft sprocket and the crankshaft sprocket are positioned as shown in fig. 18.

Remove the distributor cap, and scribe a line on the distributor housing and cylinder block to mark the posi-

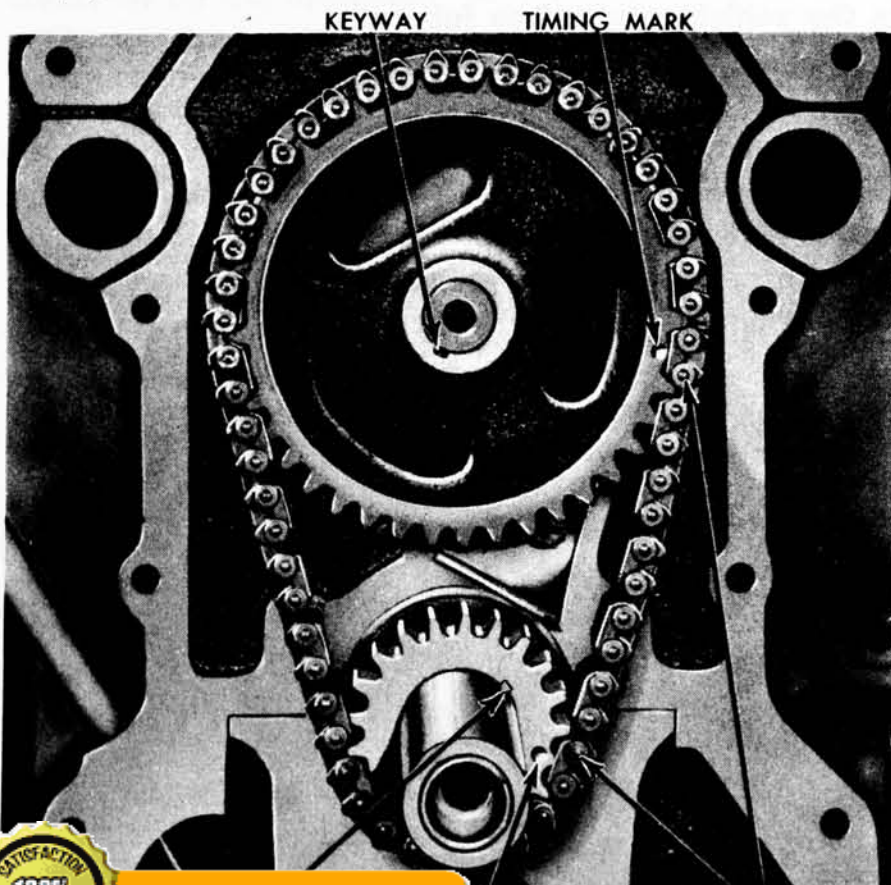

G MARK
2 PINS BETWEEN MARKS 6360

Timing Marks

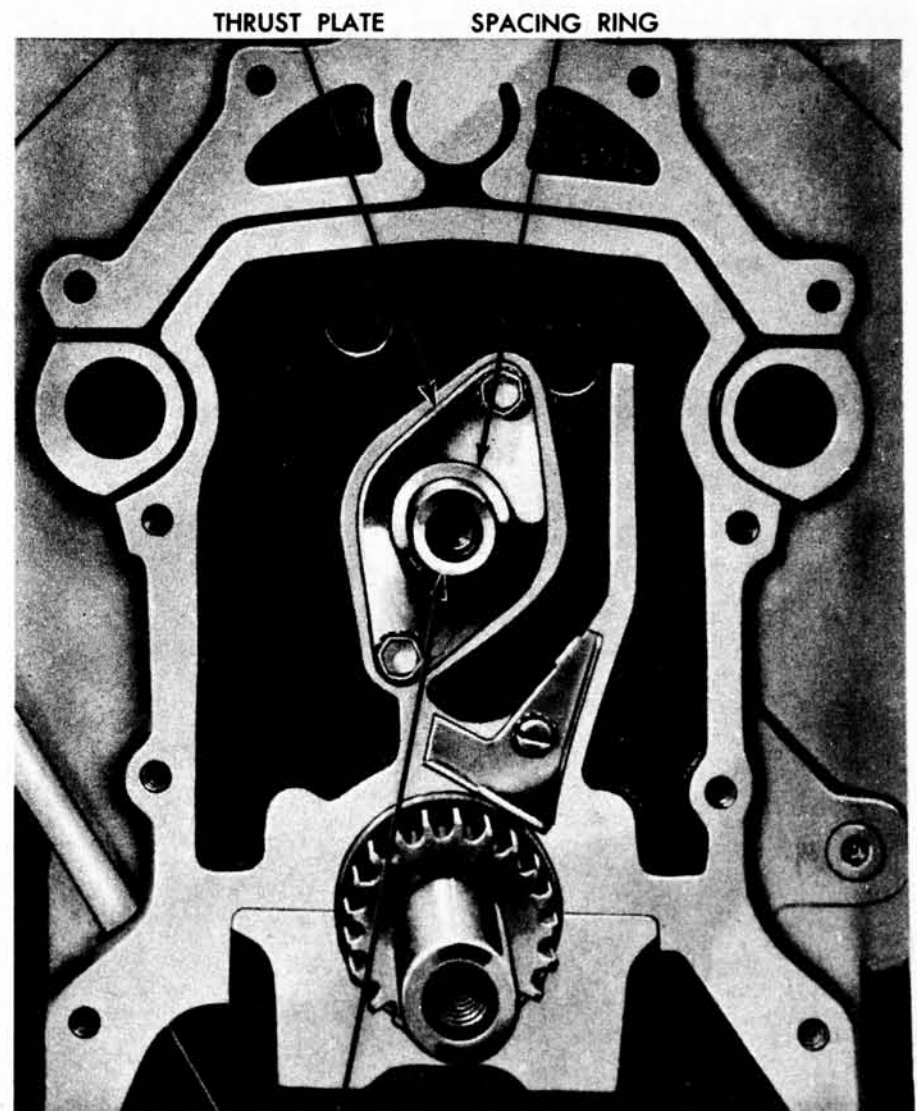

CAMSHAFT

6206

Fig. 19—Camshaft Thrust Plate

100% SATISFACTION GUARANTEED

BUY IT NOW!

Click Here To Order

PayPal, American Express, Discover, MasterCard, VISA

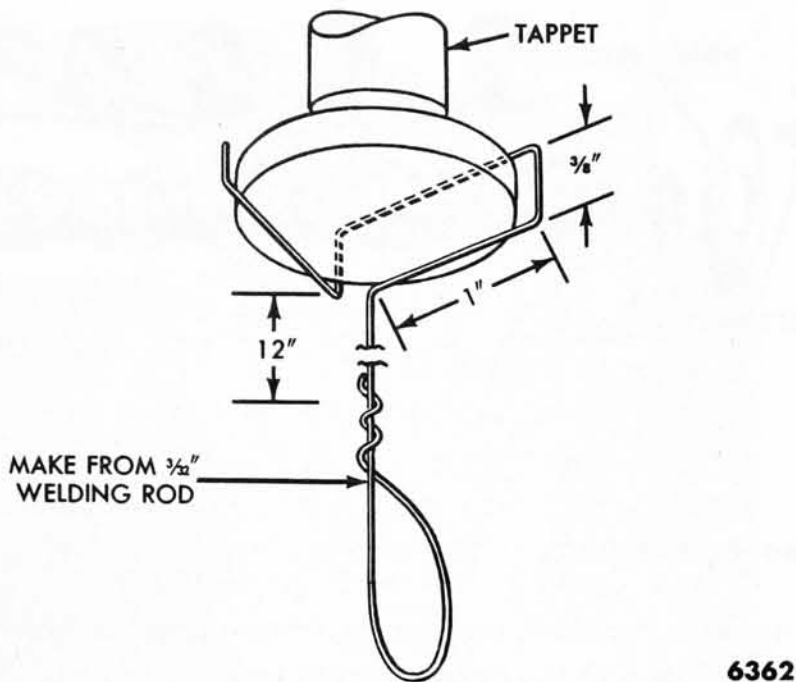

Fig. 20—Tappet Replacing Tool

tion of the rotor and distributor housing. Remove the distributor.

Remove the fuel pump eccentric, camshaft sprocket, and timing chain. Remove the camshaft thrust plate, woodruff key, and spacer ring. Use a magnetic lifter to lift the tappets, then install clothes pins, or window regulator spring clips, on each tappet to keep the tappets up. Carefully remove the camshaft by pulling toward the front of the engine.

NOTE: Exercise the necessary caution to avoid damaging the camshaft bearings.

(2) **INSTALLATION.** Oil the camshaft and carefully

Tool—T52L - 6261 - CEE
 Remover adapter—T54L - 6250 - A (Detail No. 2)
 Replacer adapter—T54L - 6250 - A (Detail No. 1)



100% SATISFACTION GUARANTEED
BUY IT NOW!
 Click Here To Order

PayPal, American Express, Discover, MasterCard, VISA

Bearing Removal

slide it through the bearings. Install the thrust plate and spacer ring. Tighten the bolts to 12-15 foot-pounds torque. Install the woodruff key in the camshaft.

Install the camshaft sprocket, crankshaft sprocket, and timing chain. Be sure the timing marks on the camshaft sprocket and crankshaft sprocket are positioned as shown in fig. 18, and there are 12 link pins between the marks. Install the fuel pump eccentric counterweight, eccentric, spacer, washer, and camshaft sprocket bolt.

Install a dial indicator and check the camshaft end play. The end play should be 0.003-0.007 inch. If the end play is excessive, replace the thrust plate and check the end play again. Remove the dial indicator, then remove the tappet holders.

Install the push rods in the same holes from which they were removed. Install the rocker arm assemblies. Install the distributor in the cylinder block, using the scribed lines as guides to properly position the rotor and housing. Install the distributor cap.

Install the cylinder front cover. Install the fuel pump, crankshaft pulley, and the water pump and fan blade assembly. Install the fan belt, radiator, and radiator grille.

Install the valve push rod chamber cover and the intake manifold. Connect the radiator hoses, vacuum lines, and fuel lines. Connect the accelerator linkage and the choke wire at the carburetor. Fill the cooling system.

Make a preliminary valve lash adjustment (cold), and thoroughly warm up the engine. Make a final valve lash adjustment (hot). Install the rocker arm covers.

c. Tappet Replacement.

To replace the valve tappets with the engine installed in the vehicle, proceed as follows:

Remove the radiator and radiator grille support. Remove the fuel pump. Remove the engine front steady rest. Remove the cylinder timing gear front cover. Remove the intake manifold, carburetor, and coil as an assembly. Remove the valve push rod cover. Remove the rocker arm covers, rocker arm assemblies, and valve push rods. Remove the distributor. Remove the camshaft

Tool—T54L - 6266 - A (Adapter)



Tool—T53L-200-A (Handle)

Fig. 22—Camshaft Rear Bearing Bore Plug Removal

sprocket and timing chain. Turn the camshaft until the tappets can be lifted with either a magnet or the fingers, raise the tappets clear of the camshaft lobes, and secure them with clothespins or window regulator spring clips. Remove the camshaft. Remove the oil pan. Remove and install one tappet at a time through the bottom of the block. A Bonney flexible tappet replacing tool or a holder, fabricated as shown in fig. 20, can be used for this operation. As each new tappet is installed, secure it with a clothespin or window regulator clip. Install the camshaft.

d. Camshaft Bearing Replacement.

Remove the engine and mount it on a workstand. Remove the distributor, spark plugs, rocker arm assemblies, push rods, generator, oil pump assembly, oil pan, cylinder front cover, timing chain and sprockets, clutch assembly, flywheel, crankshaft, camshaft, and valve tappets. Push the pistons to the top of the cylinders to move the connecting rods out of the way.

(1) **REMOVAL.** Drill a 1/2-inch hole through the plug at the camshaft rear bearing bore, then remove the plug with the clutch pilot bearing remover (7600-E). Pull the

bearings out of the block with the bearing replacement tool shown in fig. 21.

(2) **INSTALLATION.** The same tool shown in fig. 21 is used to install the bearings. A bearing adapter with a larger flange is used to install the bearings in the cylinder block.

NOTE: *The No. 1 camshaft bearing has one oil hole. The other four camshaft bearings have five oil holes and are interchangeable.*

Be sure to align the oil holes in the camshaft bearings with the oil holes in the cylinder block when the bearings are installed. Particular care should be taken with No. 3 cam bearing since it supplies oil to the rocker arms. After all the bearings are installed, coat a new camshaft rear bearing bore plug with oil resistant sealer and install the plug as shown in fig. 22.

Install the valve tappets, camshaft, crankshaft, flywheel, clutch assembly, timing chain and sprockets, cylinder front cover, oil pan, oil pump assembly, generator, push rods, rocker arm assemblies, spark plugs, and distributor. Install the engine. Set and adjust the ignition timing and valve lash.

6. FLYWHEEL, CRANKSHAFT, AND BEARINGS

The crankshaft and related parts are shown in fig. 23.

a. Flywheel.

The flywheel is piloted on a shoulder and is retained on the crankshaft by six bolts. The flywheel can only be bolted on in one position. The flywheel ring gear is a shrink fit on the flywheel.

On standard or overdrive equipped vehicles, the rear face of the flywheel is used as a friction surface which is engaged by the clutch disc. The flywheel can be checked for runout, removed, and installed with the engine mounted in the vehicle.

The flywheel used on Fordomatic equipped vehicles has two spring-steel drive plates riveted to the outer edge 180° apart, to which the converter cover is attached (fig. 24).

The following removal and installation procedures apply to all vehicles, except a Fordomatic equipped Thunderbird.

NOTE: *The Fordomatic cannot be removed as a separate assembly from the Thunderbird; therefore, it will be necessary to remove the engine from the vehicle in order to replace the flywheel.*

(1) **REMOVAL — STANDARD OR OVERDRIVE TRANSMISSION.** Remove the transmission. Remove the converter cover. Remove the clutch disc. Remove the clutch pres-

(2) **INSTALLATION — STANDARD OR OVERDRIVE TRANSMISSION.** Position the flywheel on the crankshaft. Tighten the bolts alternately and evenly, to seat the flywheel, to 75-85 foot-pounds torque. Using a pilot shaft to locate the clutch disc, install the pressure plate and disc. Install the clutch release rod, bearing, spring, and hub. Install the flywheel housing dust cover. Install the transmission.

(3) **REMOVAL—FORDOMATIC.** Remove the two rubber plugs from the floor pan, then remove the converter housing to engine block upper bolts. Raise the front of the vehicle and position safety stands. Remove the transmission control linkage shield, the torque converter lower access plate, the torque converter air inlet shield, and the torque converter front access plate. Turn the torque converter until the drain plug is at the lower edge. Drain the transmission and torque converter.

Remove the drive shaft. Disconnect the speedometer cable and transmission control rod at the transmission. Remove the battery cable from the starter, then remove the starter. Remove the transmission dipstick, then remove the filler tube.

Install the drain plug in the torque converter. Position a jack under the transmission. Remove the transmission support bolts. Remove the frame cross member at the rear of the transmission. Remove the two lower bolts securing the torque converter housing to the engine block. Move the transmission back far enough to clear the flex drive plate. Secure the torque converter to the housing.



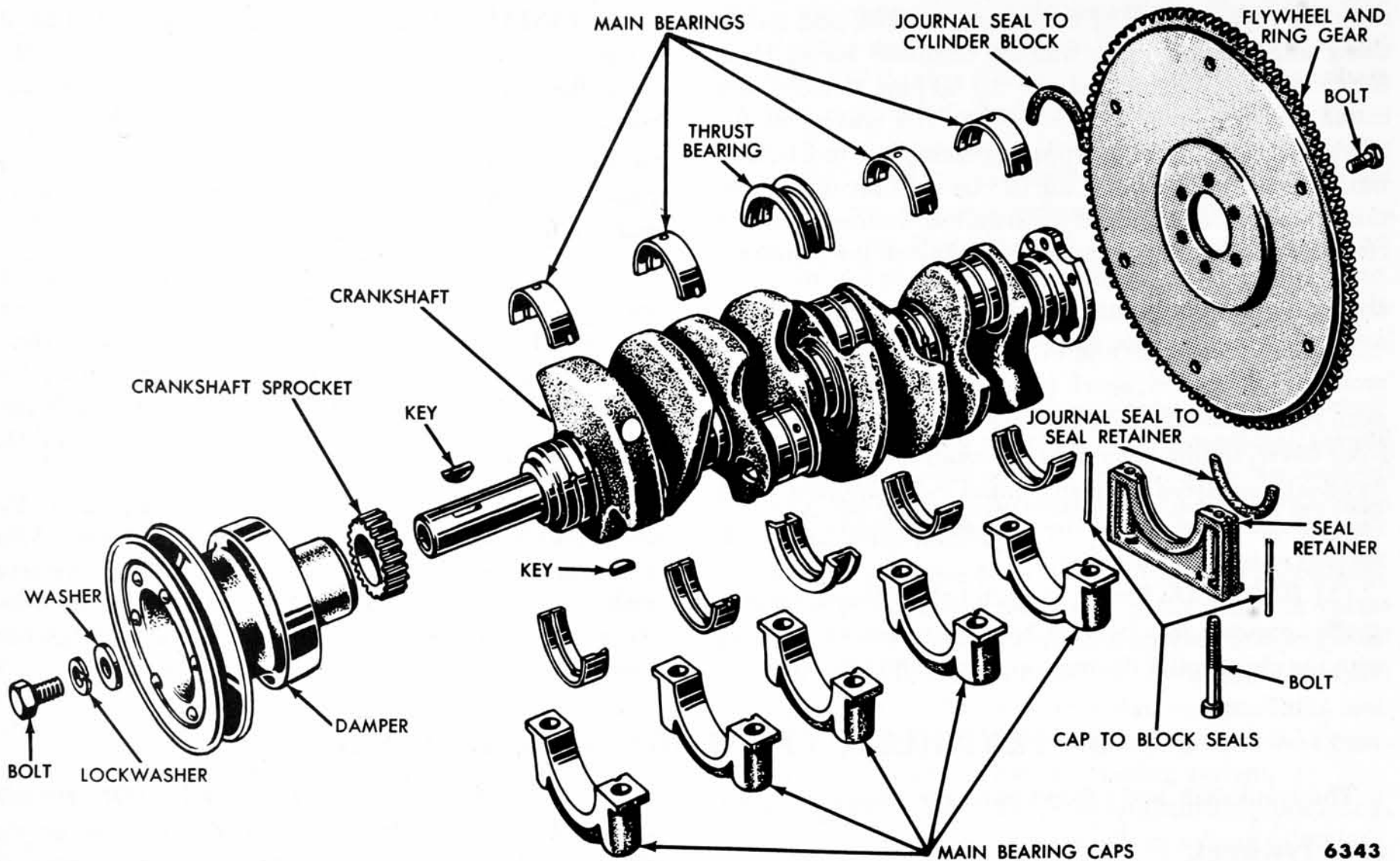

Fig. 23—Crankshaft and Related Parts

6343

CAUTION: *If the torque converter is not secured, it will slide off the splines.*

Remove the flex drive plate from the crankshaft.

(4) **INSTALLATION — FORDOMATIC.** Install the

flex drive plate on the engine crankshaft. Tighten the retaining bolts to 75-85 foot-pounds torque. Align the converter pilot and the housing dowel holes, then install the lower torque converter housing to engine block bolts. Install the flex plate to converter bolts. Install the frame cross member. Remove the jack. Install the transmission rear support bolts.

Connect the transmission throttle control linkage, the manual control linkage, and the speedometer cable. Install the torque converter air inlet shield, control linkage shield, torque converter housing front access cover, the torque converter lower access cover, and the oil filler pipe.

Install the starter, then connect the battery cable to the starter. Install the drive shaft. Remove the safety stands and lower the vehicle. Install the converter housing to engine block bolts. Install the rubber plugs and position the floor mat.

Fill the transmission with fluid. Start the engine to fill the torque converter, then add fluid until the proper level is reached on the dipstick. Check for leaks. Check and adjust the manual control, the neutral switch, the throttle linkage, the engine idle, and the dash pot.



6086

100% SATISFACTION GUARANTEED
BUY IT NOW!
 Click Here To Order

Assembly—Fordomatic



b. Crankshaft.

The crankshaft is made from a cast iron alloy. It has integral counterweights and is statically and dynamically balanced.

(1) **REMOVAL.** Remove the engine from the vehicle and mount it on an engine stand. Drain the oil. Remove the generator and fuel pump. Remove the oil pump, then remove the oil pan and oil inlet pipe as an assembly. Remove the crankshaft pulley. Remove the cylinder front cover with the fan and water pump as an assembly. Remove the crankshaft pulley spacer and woodruff key. Remove the crankshaft and camshaft sprockets with the timing chain. Remove the clutch assembly. Remove the flywheel. Remove the crankshaft rear oil seal retainer. Remove the connecting rod bearing caps, using care not to intermix the bearing inserts or caps, then carefully push the piston and rod assemblies down against the head.

Remove the main bearing caps, and mark them for installation on the same journals. Carefully lift the crankshaft out of the cylinder block so the thrust bearing surfaces are not damaged. Be sure all parts are identified so they can be installed in their original positions.

(2) **INSTALLATION.** Be sure that all bearings and crankshaft journals are clean. Install a new crankshaft rear oil seal in the cylinder block. Apply a light coat of engine oil to the crankshaft journals and the bearing inserts. Carefully lay the crankshaft in the bearings. Install the main bearing caps and tighten all the caps, except the thrust bearing cap, to 95-105 foot-pounds torque. Align the thrust bearing. Using new seals, install the crankshaft rear bearing oil seal retainer. Check the crankshaft end play with a dial indicator.

CAUTION: *The thrust bearing inserts must be in proper alignment with the crankshaft or premature bearing failure may occur.*

Pull the piston and rod assemblies against the crankshaft, and install the bearing inserts and caps. Tighten the bearing caps to 45-50 foot-pounds torque.

Install the flywheel and the clutch assembly. Install the crankshaft and camshaft sprockets with the timing chain. Install the cylinder front cover with the fan and

water pump as an assembly. Install the crankshaft pulley. Install the oil pan, oil pump, and oil pump inlet pipe.

Install the fuel pump and generator. Fill the crankcase with the proper grade and quantity of lubricant. Install the engine. Check and adjust the ignition timing.

c. Main Bearings.

The number three main bearing is the crankshaft thrust bearing.

The bearings can be replaced when the crankshaft is removed, or they can be replaced without removing the crankshaft as follows:

Replace one bearing at a time, leaving the other bearings securely fastened. Remove the bearing cap and the insert. Install the bearing removing tool as shown in fig. 25. Rotate the crankshaft to slide the bearing out of the block. Install a new bearing insert on the crankshaft journal. Rotate the crankshaft, in the opposite direction to that used for removal, until the insert is in place.

NOTE: *Be sure the notched end of the bearing is placed so it will seat when rotated into position.*

Check the bearing fit using the Plastigage method as outlined in Chapter I—"General Engine Repair."

Install the new bearing insert in the cap, oil the crankshaft journal with engine oil, and install the cap and insert. Tighten the main bearing cap bolts to 95-105 foot-pounds torque. Repeat the procedure for the remaining bearings if they need replacement. Install the oil pan.

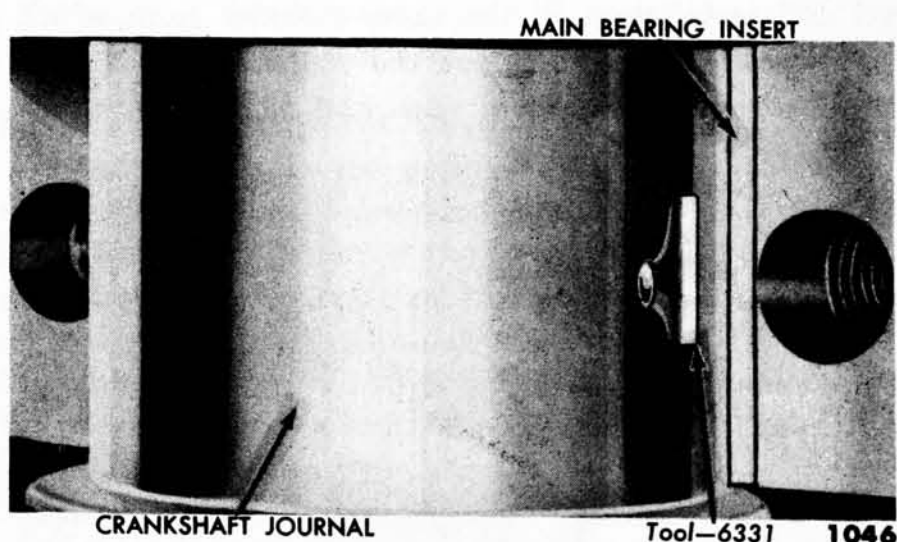

Fig. 25—Main Bearing Insert Removal

7. CONNECTING RODS, PISTONS, PINS, AND RINGS

The piston and connecting rods are shown disassembled in fig. 26.

a. Piston and Connecting Rod Removal.

Remove the oil pan and cylinder heads. Before re-assembly, remove any ridge at the top of the cylinder bore caused by piston ring wear, and

Turn the crankshaft until the rod of the piston being removed is down. Remove the pal nuts and the hex head nuts from the connecting rod bolts. Lift the cap and the bearing insert from the rod then remove the insert from the cap and the rod, and mark both halves to assure assembly with the same connecting rod. Push the rod and piston assembly out of the top of the cylinder with the handle end of a hammer. Do not scratch the crank-

100% SATISFACTION GUARANTEED

BUY IT NOW!

Click Here To Order

PayPal, American Express, Discover, MasterCard, VISA

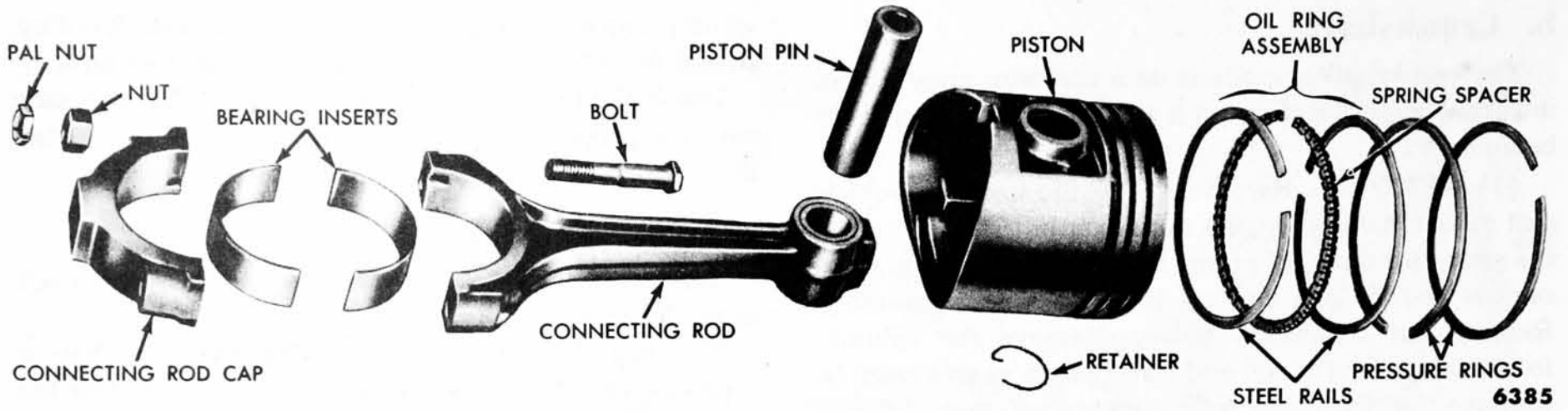

Fig. 26—Piston and Connecting Rod—Disassembled

pin or the cylinder wall when removing the piston and rod. Repeat this procedure for each assembly.

NOTE: *Connecting rod and bearing cap assemblies are numbered from 1 to 4 in the right bank and from 5 to 8 in the left bank, beginning at the front of the engine. The numbers on the rod and bearing cap must be on the same side when installing them into their respective cylinder bores. If a connecting rod is ever transposed from one block or cylinder to another, make sure all bearings are new and that the number on the rod is restamped to correspond with the new cylinder number.*

b. Disassembly.

Mark the pistons to assure assembly with the same rod and installation in the same cylinder from which they were removed. Remove the piston rings. Remove the piston pin retainers at each end of the piston pin,

then remove the piston pin (fig. 27). Discard the retaining clips.

c. Assembly.

Lubricate all parts with light engine oil.

Assemble the connecting rods and pistons as shown in figs. 28 and 29.

Install the piston pin through the piston and rod, then install the pin retainers by spiraling them into the piston with the fingers. Do not use pliers. Install the piston rings, starting with the oil ring first. Position the butt ends of the oil ring expander toward the center of the engine, then spiral the steel rails onto the expander and position the gaps one inch to either side of the expander butt ends. Position the compression rings so that all gaps are 120° apart. Install the insert bearings in the connecting rod and the connecting rod cap.

d. Installation.

NOTE: *Install the piston with the indentation in the piston head toward the front of the engine. When installed, the rod bearing lock slot in the connecting rod should be toward the outside of the engine “V.”*

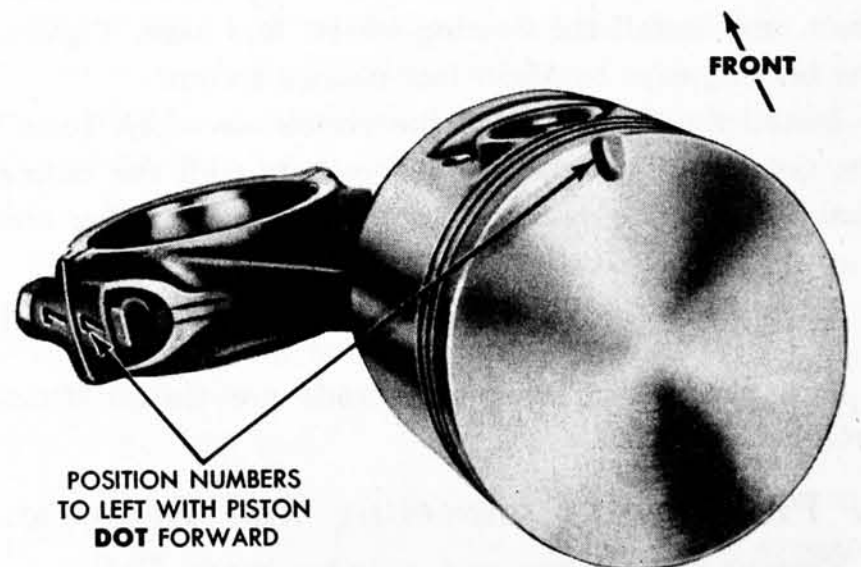

6386

6395

Fig. 28—Position of Rod Numbers—Left Bank

100% SATISFACTION GUARANTEED
BUY IT NOW!
 Click Here To Order

PayPal, American Express, Discover, MasterCard, VISA

Pin Removal

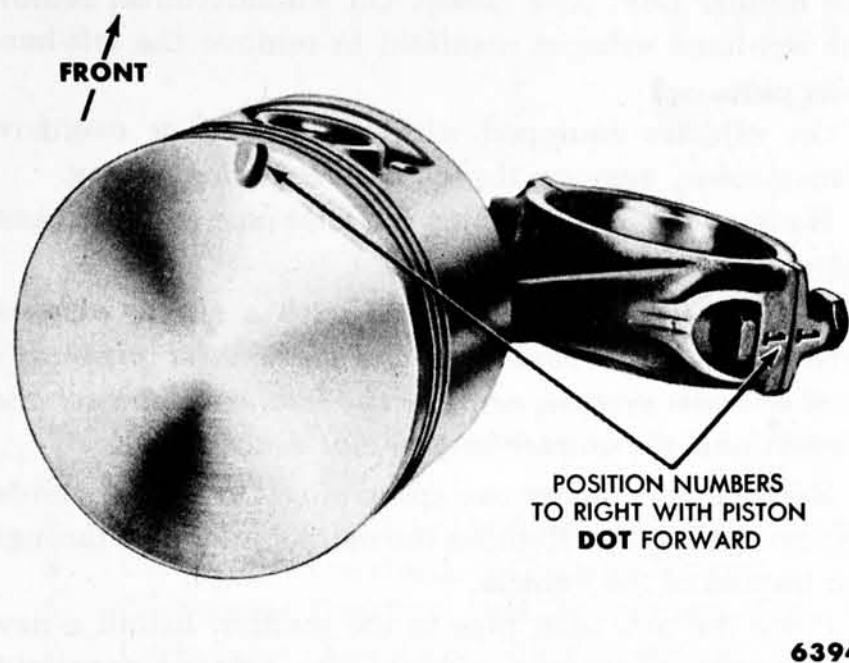

Fig. 29—Position of Rod Numbers—Right Bank

Oil the piston rings, piston, connecting rod bearings, and cylinder walls with light engine oil. Install a piston ring compressor on the piston, and insert the piston in the cylinder. Be sure to install pistons in the same cylinders from which they were removed or to which they were fitted. If a new piston and connecting rod is to be installed, be sure to stamp the cylinder number on the connecting rod and connecting rod cap so the numbers will face the outside of the engine when the assembly is installed. Push the piston into the cylinder as shown in fig. 30. Turn the crankshaft throw to the bottom of its

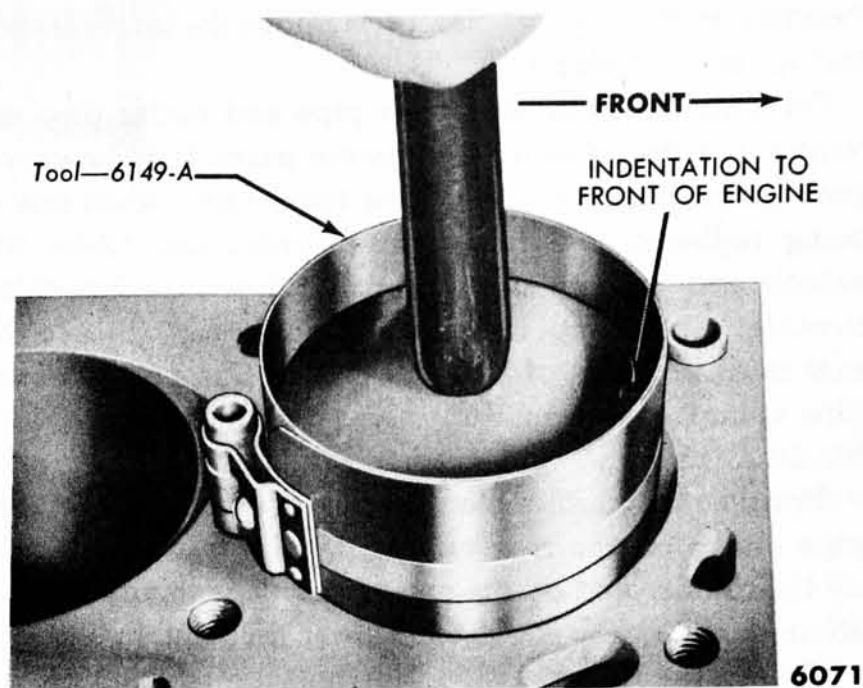

Fig. 30—Piston Installation

stroke. Oil the crankpin, and push the piston downward until the rod bearing seats in the crankpin.

Be careful not to damage the crankpin journals with the connecting rod bolts when the piston is pushed into the cylinder bore. Check the bearing fit using the Plastigage method as outlined in the General Engine Repair Chapter.

After the connecting rod caps have been tightened to specifications, install the oil pan. Install the cylinder heads and manifolds. Fill the crankcase with the proper grade and quantity of engine oil. Fill the cooling system.

8. EXHAUST SYSTEM

The single exhaust system (fig. 31) consists of a muffler, a muffler inlet pipe, a muffler outlet pipe, and a crossover pipe.

The Interceptor, Thunderbird, Station Wagon, and Fairlane models are equipped with a dual exhaust system as standard equipment. The dual exhaust system is also installed on other models as optional equipment. This system consists of two muffler inlet pipes, two mufflers, and two outlet pipes. In addition, the Thunderbird has a muffler outlet pipe extension. The dual exhaust system is designed to facilitate rapid scavenging of the exhaust gases, thereby, minimizing exhaust gas back pressure.

Inlet pipes, mufflers, outlet pipes, and outlet pipe extensions (Thunderbird) are provided as individual service parts.

The procedures given apply to all models unless otherwise stated. The outlet pipe replacement procedure for the Thunderbird varies slightly because of the outlet pipe extension.

a. Muffler Replacement.

Raise the vehicle and position safety stands. Loosen the muffler inlet and outlet pipe clamps. Slide the clamps away from the muffler on the inlet pipe and the outlet pipe. Loosen the outlet pipe front and rear clamps and disengage the outlet pipe from the muffler by sliding the outlet pipe to the rear. On Thunderbirds, disconnect the inlet pipe from the manifold. Remove the muffler from the inlet pipe.

Place the new muffler in position on the inlet pipe then slide the outlet pipe into the muffler. Place the inlet pipe and outlet pipe clamps in position on the muffler and tighten the clamps. Tighten the front and rear outlet pipe clamps. Remove the safety stands and lower the vehicle.

b. Outlet Pipe Replacement.

To replace an outlet pipe (except Thunderbirds), raise the vehicle and position safety stands. Loosen the outlet pipe clamp at the muffler. Remove the outlet pipe support clamps, then pull the outlet pipe from the muffler. Position the muffler clamp on the new outlet pipe, then slide the pipe into the muffler. Install, but do not tighten, the support clamps. Tighten the outlet pipe to muffler clamp,

100% SATISFACTION GUARANTEED

BUY IT NOW! part of the exhaust system—connecting bracket clamps to use when tightening the clamps.

Click Here To Order

PayPal American Express Discover MasterCard VISA

then tighten the support clamps. Remove the safety stands and lower the vehicle.

On Thunderbirds, the outlet pipe and outlet pipe extension can be replaced as separate parts. It is, however, good practice to replace both of these parts when one is being replaced due to a rusting condition. Raise the vehicle and position safety stands. Loosen the extension to outlet pipe clamp, then slide the extension pipe to the rear until it is free of the outlet pipe. Loosen the outlet pipe clamp at the muffler, then pull the outlet pipe off the muffler.

Position the muffler clamp and the extension to outlet pipe clamp on the new outlet pipe, then slide the pipe on the muffler and on the extension. Tighten the clamps. Remove the safety stands and lower the vehicle.

To replace the extension pipe only on a Thunderbird, loosen the extension to outlet pipe clamps. Slide the extension to the rear until it is free of the outlet pipe, then pull it forward until it comes free of the support hanger located at the bumper.

Position a new extension through the support hanger (this is a slip fit) and into the exhaust outlet in the bumper. Slide the extension to the rear until it can be aligned with the outlet pipe. Slide the extension into the outlet pipe. Position and tighten the clamp.

NOTE: *If both the outlet pipe and outlet pipe extension are to be replaced, remove the extension, then remove the outlet pipe.*

c. Inlet Pipe Replacement.

Raise the vehicle and position safety stands. Loosen

the muffler inlet pipe clamp. On Thunderbirds, remove the left-hand exhaust manifold to remove the left-hand inlet pipe.

On vehicles equipped with a standard or overdrive transmission, remove the clutch retracting spring.

Remove the nuts retaining the inlet pipe to the exhaust manifold.

NOTE: *On vehicles equipped with a single exhaust system, or when replacing the right inlet pipe on a dual exhaust system, remove the heater inlet duct and motor, and the starter motor and seal.*

Remove the number two spark plug. On Thunderbirds, remove the muffler. Remove the muffler inlet pipe through the bottom of the vehicle.

Place the new inlet pipe in the muffler. Install a new gasket and secure the pipe to the exhaust manifold. Tighten the nuts to 23-28 foot-pounds torque. Tighten the muffler inlet pipe clamp. Install the number two spark plug. Install the starter motor and seal and the heater inlet duct and motor, if they were removed. Remove the safety stands and lower the vehicle.

d. Crossover Pipe Replacement.

Remove the nuts and lockwashers retaining each end of the pipe to the manifolds. Remove the crossover pipe, manifold heat control valve, and gaskets.

Position the manifold heat control valve on the right-hand manifold with a new gasket on each side. Position a new gasket on the left-hand manifold, then install the crossover pipe. Tighten the nuts to 23-28 foot-pounds torque.

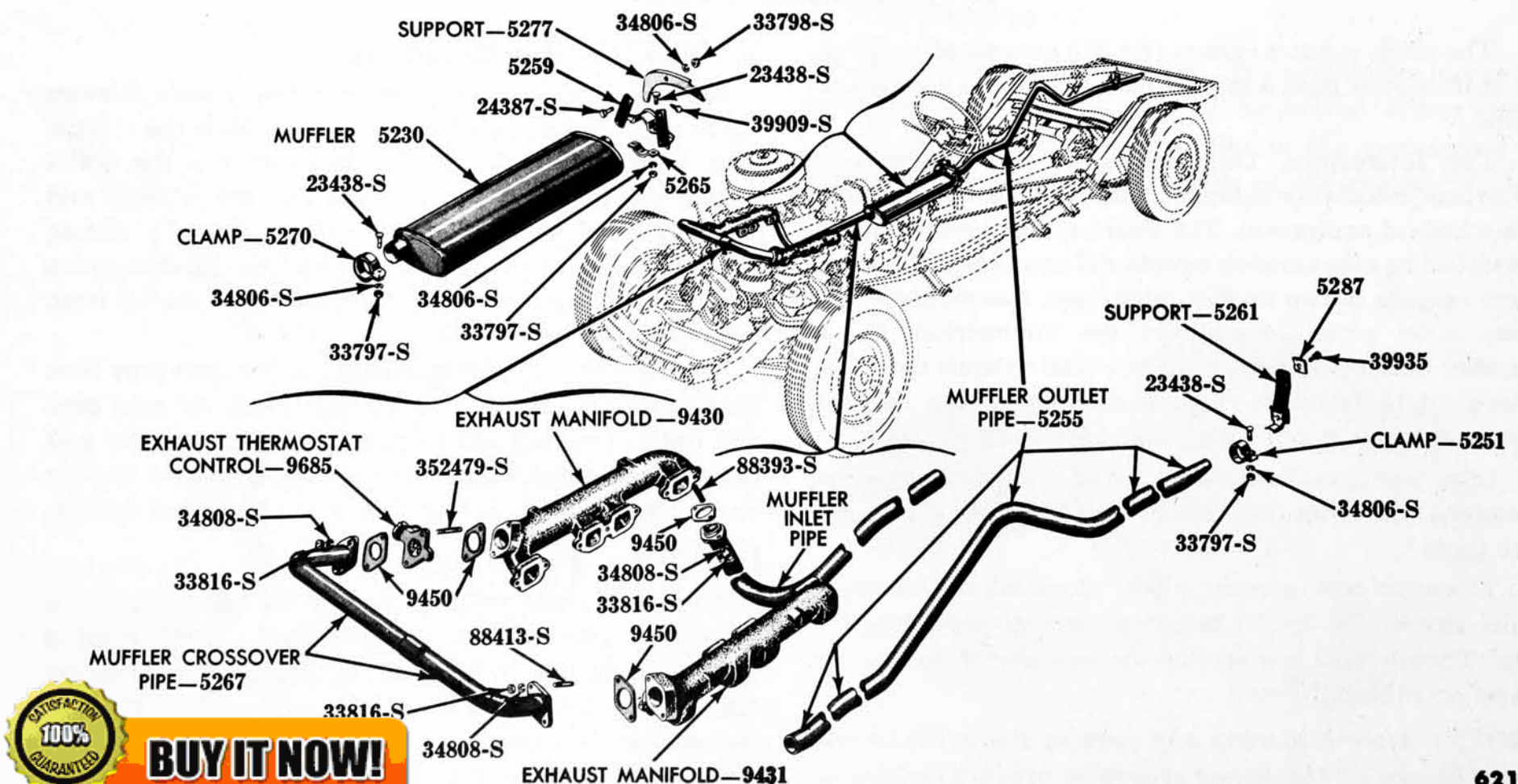

Fig. 31—Muffler and Related Parts—Single Exhaust System

100% SATISFACTION GUARANTEED

BUY IT NOW!

Click Here To Order

PayPal, American Express, Discover, MasterCard, VISA

1 9 5 5

**FORD
CAR
SHOP MANUAL**



100% SATISFACTION GUARANTEED

BUY IT NOW!

Click Here To Order 

PayPal  Cards   