

1954-55

FORD TRUCK SHOP MANUAL

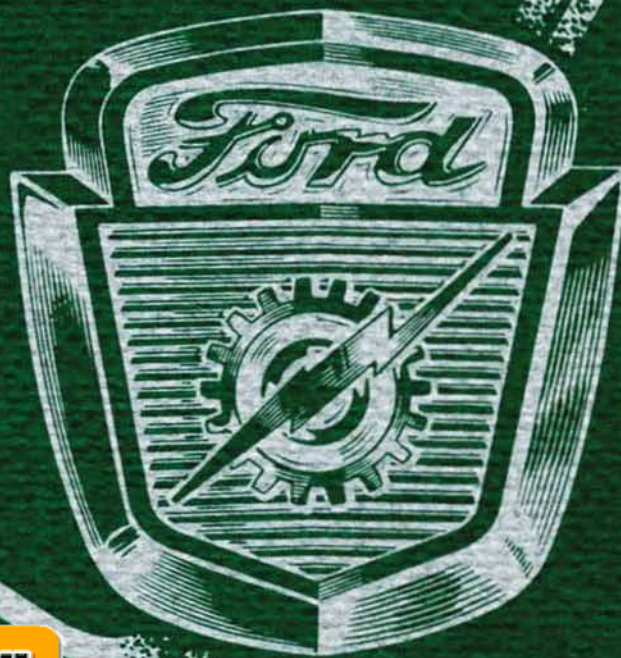

License #2011747



BUY IT NOW!

Click Here To Order 



...ION • FORD MOTOR COMPANY

Copyright © 2011, Forel Publishing Company, LLC, Woodbridge, Virginia

All Rights Reserved. No part of this book may be used or reproduced in any manner whatsoever without written permission of Forel Publishing Company, LLC. For information write to Forel Publishing Company, LLC, 3999 Peregrine Ridge Ct., Woodbridge, VA 22192

1954-55 Ford Truck Shop Manual

EAN: 978-1-60371-064-0

ISBN: 1-60371-064-7

Forel Publishing Company, LLC

3999 Peregrine Ridge Ct.

Woodbridge, VA 22192

Email address: sales@ForelPublishing.com

Website: <http://www.ForelPublishing.com>



This publication contains material that is reproduced and distributed under a license from Ford Motor Company. No further reproduction or distribution of the Ford Motor Company material is allowed without the express written permission of Ford Motor Company.

Note from the Publisher

This product was created from the original Ford Motor Company's publication. Every effort has been made to use the original scanned images, however, due to the condition of the material; some pages have been modified to remove imperfections.

Disclaimer

Although every effort was made to ensure the accuracy of this book, no representations or warranties of any kind are made concerning the accuracy, completeness or suitability of the information, either expressed or implied. As a result, the information contained within this book should be used as general information only. The author and Forel Publishing Company, LLC shall have neither liability nor responsibility to any person or entity with respect to any loss or damage caused, or alleged to be caused, directly or indirectly by the information contained in this book. Further, the publisher and author are not engaged in rendering legal or other professional advice. If legal, mechanical, electrical, or other expert assistance is required, the assistance of a professional should be sought.



1954-55

FORD TRUCK SHOP MANUAL

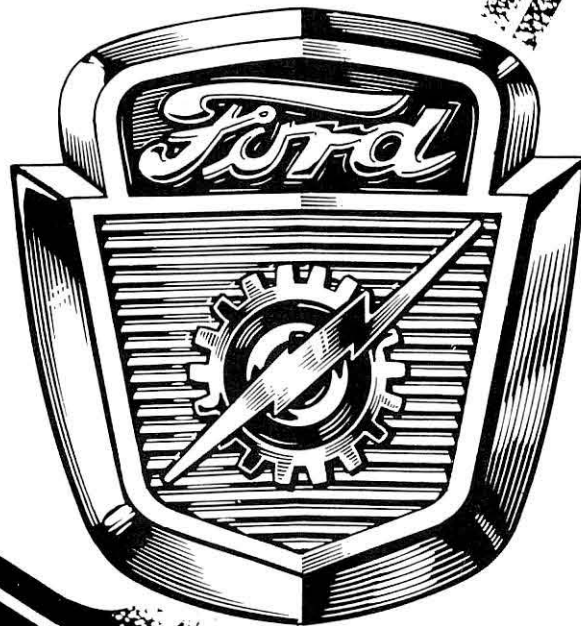

Copyright 1954
FORD MOTOR COMPANY
DEARBORN, MICHIGAN
All rights reserved



BUY IT NOW!

Click Here To Order

ON • FORD MOTOR COMPANY



November, 1954

FOREWORD

This manual contains complete service information for 1954 and 1955 Ford trucks. Step-by-step procedures for trouble shooting, cleaning and inspecting, repairing, and replacing the various parts, assemblies, and systems on the truck are presented here. This manual also contains maintenance and lubrication data as well as a tabulation of truck specifications. Detailed illustrations of many of the service operations are given here. Disassembled views of some of the truck units show the various parts in the order of their disassembly or assembly. In many cases, a glance at these illustrations will tell you all you need to know about how parts go together.

The material presented in this manual is arranged in five main parts as listed in the Table of Contents on the following pages. Under each part, chapter headings covering the major subjects in each part are given. The section headings under each chapter title indicate the subjects covered in the chapter.

Part ONE—POWER PLANT—has to do with the Ford truck engines and the various systems that are necessary to their operation. These include the fuel, ignition, and cooling systems.

Part TWO—CHASSIS—contains information on the entire power train (clutch, conventional transmissions, Overdrive, drive lines, rear axles, etc.) and the running gear (frames, springs, suspension, brakes, wheels, tires, steering gear, steering linkages, etc.). Service procedures for the Fordomatic transmission are published in a separate manual.

Part THREE—ELECTRICAL AND ACCESSORIES—covers all of the electrical systems and units (except the ignition system) and all of the accessories (except the Overdrive and Fordomatic).

Part FOUR—BODIES—contains information on the maintenance and repair of all body components, including adjustment and alignment of doors, hoods, and fenders. In addition, window glass adjustments are given in this part.

Part FIVE—MAINTENANCE AND SPECIFICATIONS—gives complete maintenance and lubrication information, and contains all the specifications necessary for the proper servicing of Ford trucks.

Throughout this manual, the top of each left-hand, even-numbered page gives the name of the chapter, and the top of each right-hand, odd-numbered page gives the name of the section involved on the page. Thus, wherever you open the manual, a glance at the top of the two pages will tell you exactly what subject matter is discussed at that point.

This manual has been prepared to help you in doing a good servicing job on Ford trucks. Keep your manual where it will be readily available for reference at all times.

FORD DIVISION
FORD MOTOR COMPANY
SERVICE DEPARTMENT



TABLE OF CONTENTS

Foreword	Page	2
----------------	------	---

Part ONE—POWER PLANT

CHAPTER I—GENERAL ENGINE REPAIR

Section	Page	Section	Page
1 Trouble Shooting	5	7 Flywheel, Crankshaft, Main Bearings, and Connecting Rod Bearings	22
2 Engine Tune-Up	8	8 Oil Pan, Oil Filter, and Oil Pump and Pressure Relief Valve	26
3 Engine Removal and Installation	10	9 Cylinder Block, Pistons, Piston Rings, and Connecting Rods	27
4 Intake and Exhaust Manifolds	15	10 Exhaust System	29
5 Rocker Mechanism, Cylinder Head, Valves, Valve Lash Adjustment, and Valve Timing	15		
6 Camshaft Sprocket, Camshaft, and Camshaft Bearings	21		

CHAPTER II—6-CYLINDER 223 CUBIC INCH (EBR, EBS, AND EBT) ENGINES

1 Manifolds	30	5 Camshaft Sprocket, Camshaft, and Bearings	36
2 Cylinder Head and Valves	31	6 Flywheel, Crankshaft, and Bearings	37
3 Oil Pan and Oil Pump and Pressure Relief Valve	33	7 Connecting Rods, Pistons, Pins and Rings	39
4 Crankshaft Damper, Cylinder Front Cover, and Oil Seal	34	8 Exhaust System	40

CHAPTER III—8-CYLINDER 239 (EBV AND EBW) AND 256 (EBZ) CUBIC INCH ENGINES

1 Manifolds	43	5 Camshaft Sprocket, Camshaft, and Bearings	50
2 Cylinder Head and Valves	44	6 Flywheel, Crankshaft, and Bearings	52
3 Oil Pan and Oil Pump and Pressure Relief Valve	47	7 Connecting Rods, Pistons, Pins, and Rings	54
4 Crankshaft Pulley, Engine Front Support Bracket, Cylinder Front Cover and Oil Seal	48	8 Exhaust System	56

CHAPTER IV—8-CYLINDER 279 (EAL) AND 317 (EAM) CUBIC INCH ENGINES

1 Manifolds	57	5 Camshaft Sprocket, Camshaft, and Bearings	63
2 Cylinder Head and Valves	58	6 Flywheel, Crankshaft and Bearings	65
3 Oil Pan and Oil Pump and Pressure Relief Valve	61	7 Connecting Rods, Pistons, Pins, and Rings	67
4 Crankshaft Damper and Cylinder Front Cover	62	8 Exhaust System	69

CHAPTER V—IGNITION, FUEL, AND COOLING SYSTEMS

1 Ignition	70	8 Fuel Tanks and Lines	98
2 Distributor Minor Repair and Adjustments	75	9 Fuel Pumps, Vacuum Boosters, and Fuel Filter	99
3 Distributor Overhaul	77	10 Governors	102
4 Carburetor Operation and Adjustments	83	11 Fans and Belts	104
5 Carburetor Overhaul—223 Cubic Inch Engine	89	12 Water Pumps	105
6 Carburetor Overhaul—239 Cubic Inch Engine	93	13 Cooling System—Radiator, Hose, and Thermostat	108
7 Carburetor Overhaul—256, 279, or 317 Cubic Inch Engine	95		

Part TWO—CHASSIS

CHAPTER I—CLUTCH, TRANSMISSIONS, AND GEARSHIFT LINKAGE

1 Trouble Shooting	112	6 Light-Duty 5-Speed Transmissions	126
2 Clutch	113	7 Heavy-Duty 5-Speed Transmissions	131
3 Transmission Cleaning and Inspection	116	8 3-Speed Auxiliary Transmission	136
4 3-Speed Transmissions	117	9 Gear Shift Linkage	141
5 4-Speed Transmission	122		

CHAPTER II—OVERDRIVE

1 Operating Principles—Mechanical	142	3 Trouble Shooting	145
2 Operating Principles—Electrical	144	4 Overhaul	147

CHAPTER III—POWER STEERING

1 Construction and Operation	151	3 Overhaul	162
2 Inspection and Trouble Shooting	158		

CHAPTER IV—RUNNING GEAR

.....	170	6 Shock Absorbers	180
.....	172	7 Steering Gear	181
.....	174	8 Steering Linkage	183
.....	176	9 Wheels and Tires	185
.....	179	10 Hubs and Bearings	191



CHAPTER V—BRAKES

Section	Page	Section	Page
1 Brake Types and Model Application.....	195	6 Brake Assemblies.....	220
2 Trouble Shooting.....	196	7 Brake Drums.....	224
3 Adjustments.....	198	8 Air—Hydraulic Brake System.....	225
4 Hydraulic System.....	200	9 Air Brake System.....	230
5 Brake Boosters.....	205	10 Parking Brakes.....	241

CHAPTER VI—REAR AXLES AND DRIVE LINES

1 Trouble Shooting.....	243	6 Banjo Housing Hypoid Rear Axle.....	263
2 Cleaning and Inspection.....	244	7 Banjo Housing Spiral Bevel Rear Axle.....	268
3 Integral Housing Hypoid Rear Axle.....	246	8 Two-Speed Planetary.....	272
4 Split Housing Hypoid Rear Axle—F-250 and P-350..	252	9 Drive Lines.....	284
5 Split Housing Hypoid Rear Axle—F-350, and 700 and 750 Series.....	257		

CHAPTER VII—TANDEM REAR AXLES

1 Construction.....	288	3 Replacement.....	291
2 Operation.....	290	4 Overhaul.....	294

Part THREE—ELECTRICAL AND ACCESSORIES

CHAPTER I—GENERATING SYSTEM AND BATTERY

1 Trouble Shooting.....	312	3 Generator Regulator.....	321
2 Generator.....	315	4 Battery.....	328

CHAPTER II—STARTING SYSTEM

1 Trouble Shooting.....	332	3 Starter Drive.....	340
2 Starter and Circuit.....	335		

CHAPTER III—LIGHTING SYSTEM, HORNS, AND INSTRUMENTS

1 Trouble Shooting.....	342	3 Horns.....	349
2 Lighting System.....	345	4 Instruments.....	350

CHAPTER IV—ACCESSORIES

1 Trouble Shooting.....	355	3 Heater.....	363
2 Radio.....	358	4 Miscellaneous Accessories.....	365

Part FOUR—BODIES AND CABS

CHAPTER I—BODY CONSTRUCTION AND MAINTENANCE

1 Construction Details and Sealer Application.....	367	3 Hood Alignment.....	372
2 Door Alignment.....	370		

CHAPTER II—INTERIOR TRIM, HARDWARE, AND GLASS

1 Seats and Interior Trim.....	375	4 Door Glass and Ventilator Assembly.....	384
2 Door Locking Mechanism.....	380	5 Windshield and Rear Glass.....	387
3 Window Regulators.....	383		

CHAPTER III—FRONT END SHEET METAL AND RUNNING BOARDS

1 Front End Sheet Metal.....	389	4 Cowl Ventilator.....	391
2 Radiator Grille.....	390	5 Running Boards.....	392
3 Fenders.....	391		

Part FIVE—MAINTENANCE AND SPECIFICATIONS

CHAPTER I—MAINTENANCE

1 Preventive Maintenance.....	393	2 Lubrication.....	395
-------------------------------	-----	--------------------	-----

CHAPTER II—SPECIFICATIONS

1 Wheel and Tires.....	399	8 Cooling System.....	410
2.....	400	9 Fuel System.....	410
3.....	401	10 Generating System.....	411
4.....	404	11 Starting System.....	411
5.....	406	12 Ignition.....	411
6.....	407	13 Wiring Diagram.....	413
7.....	409	14 Tools and Equipment.....	414



Part ONE
POWER PLANT

Chapter

I

General Engine Repair

Section	Page
1 Trouble Shooting	5
2 Engine Tune-Up	8
3 Engine Removal and Installation	10
4 Intake and Exhaust Manifolds	15
5 Rocker Mechanism, Cylinder Head, Valves, Valve Lash Adjustment, and Valve Timing	15
6 Camshaft Sprocket, Camshaft, and Camshaft Bearings	21
7 Flywheel, Crankshaft, Main Bearings, and Connecting Rod Bearings	22
8 Oil Pan, Oil Filter, and Oil Pump and Pressure Relief Valve	26
9 Cylinder Block, Pistons, Piston Rings, and Connecting Rods	27
10 Exhaust System	29

Trouble shooting, tune-up, inspection, and repair procedures, applicable to all engines, are given in this chapter. For the removal and installation of engine components, refer to the chapter covering the specific engine.

Inasmuch as a determination of the basic cause

of engine trouble should precede any repair work, the trouble shooting section is presented first. Many defects in engine performance can be attributed directly to a maladjustment of one part or a combination of several parts; therefore, general engine tune-up logically follows the trouble shooting section, and precedes the actual repair work.

1. TROUBLE SHOOTING

Trouble shooting is the application of a definite procedure, in a logical sequence, to locate and eliminate the cause of trouble in a particular system or unit. It should be borne in mind, when trouble shooting, to first look for the obvious causes of trouble such as an empty gas tank, a wet or cold engine, loose or disconnected wiring, or any other such item that may cause a temporary defect.

The various factors affecting power plant operation are outlined in this section.

a. Engine.

Poor engine performance can be attributed to the engine or to forces on the vehicle that tend to retard its motion. An example of a retarding force is dragging brakes which causes the engine to work harder and results in poor engine performance.

Engine performance depends on proper fuel distribution, correctly timed ignition, normal uniform compression, properly regulated flow of the fuel-air mixture to cylinders, and unobstructed flow of exhaust gases.

discussed under separate headings. What to do to correct

these conditions and regain good engine performance.

(1) **ENGINE WILL NOT CRANK.** If starter does not turn the engine over, or turns it over too slowly to start, the fault is likely to be in the battery or the starter. Perform the following checks in the order listed, until the cause of the trouble is determined:

(a) **CHECK THE BATTERY.** Try the horn or lights. If they do not operate properly, test the battery, then recharge it, or replace it, as necessary.

(b) **CHECK THE BATTERY CABLES.** Check for loose or corroded connections at the starter, solenoid, battery, and ground. Clean, tighten, or replace them as necessary.

(c) **CHECK THE SOLENOID CIRCUIT.** The solenoid surfaces seldom become so badly burned that they will prevent the starter from cranking the engine. However, other wiring may be at fault. Repair as necessary. (Refer to the Electrical System Section).

(d) **CHECK THE STARTER OR STARTER DRIVE.** If the above components are not at fault, the trouble is probably in the starter or starter drive. If the starter is running, but not engaging the flywheel, remove the starter and make the necessary repairs to the starter

drive. In rare cases, the starter drive may lock up with the flywheel. This can be corrected by loosening the starter and releasing the starter drive. If the starter does not operate, remove it and make the necessary repairs.

(2) **ENGINE CRANKS, BUT WILL NOT START.** The most probable cause of this trouble is a defect in the ignition system. The next most likely cause is a malfunction of the fuel system. A simple check will determine which system is at fault. Remove one wire from a spark plug, and insert a piece of proper sized drill rod so that it will protrude from the insulator. With the ignition on and the starter turning the engine over, hold the end of the rod approximately $\frac{3}{16}$ -inch from the block. If no spark is obtained, check the ignition system. If a good spark is obtained, check the fuel system.

(a) **NO SPARK.** If no spark was obtained, follow the steps below to determine the cause and make the necessary repairs or replacements.

(1) Pull the coil wire from the top of the distributor. Hold the wire $\frac{3}{16}$ -inch from the cylinder head, and with the ignition on and the engine turning over, see if there is a spark. If there is a good spark, the trouble lies in the distributor cap, rotor, or spark plug wires. Make sure these components are clean, dry, and not defective. Repair or replace them as necessary.

(2) If there was no spark in (1) replace the high tension wire between the coil and distributor and check again. If a weak spark exists, the points are probably arcing. Replace the condenser and adjust the points. If a weak spark persists, test the coil.

(3) If there was no spark in (2), remove the distributor cap and see if the points are opening and that there is an electrical charge to the points. Adjust or replace as necessary. If there is current at the points, and they open properly, the secondary circuit of the coil is defective. If there is no current at the points, install a "jumper" between the "Dist" terminal of the coil and the distributor, and check for current at the points. If there is current replace the wire. If there was no current, install a "jumper" between the two coil terminals and recheck. Replace the coil if current now exists at the points. If not, install a "jumper" from the battery to the ignition wire side of the coil, and check for current at the points. If there is current, the ignition switch or wiring under the instrument panel is defective and must be repaired or replaced.

(b) **WEAK SPARK.** If the spark test at the spark plug showed a weak spark, perform the following checks in the order listed:

(1) Test, recharge, or replace, the battery.

(2) Remove the distributor cap, and check the condenser and points. Replace them as necessary. Check for arcing, and if

(3) Check the condition of the rotor, distributor cap, and plug wires. The wires must be clean, dry, and must be fully seated in the terminals. Replace as necessary.

(4) If the weak spark persists, the coil should be tested and replaced if necessary.

(c) **GOOD SPARK.** If a good spark was observed, check the fuel system as follows:

(1) Check the fuel supply at the fuel tank. Do not attempt any other fuel system checks before doing this.

(2) If there is fuel in the tank, check to see if it is reaching the carburetor. Remove the air cleaner, and look down the carburetor throat while working the throttle by hand. Each time the throttle is worked, a spurt of gasoline should be emitted from the accelerator pump discharge nozzle. If there is fuel at this point, the engine was probably flooded or there is water in the fuel system.

(3) If no accelerator pump discharge is observed in the carburetor throat, loosen the fuel pump to fuel tank line at the fuel pump. Remove the fuel tank filler cap. If fuel runs out freely, the line is clean. If not, blow the line out by air pressure from the fuel pump end.

NOTE: *Check the flexible gas line for a collapsed condition.*

(4) If the cause of the trouble has not been found, check the fuel pump pressure, then repair or replace the fuel pump or carburetor.

(3) **ENGINE STARTS, BUT FAILS TO KEEP RUNNING.** The most probable cause of this malfunction is the fuel system. The ignition system sometimes can cause trouble, but it is usually after the engine has run for some time and is at operating temperature. In either case, check the fuel system first.

(a) Check the fuel supply at the gas tank.

(b) Try to start the vehicle. If it will operate with constant foot throttle, adjust the idle speed and check the choke adjustment.

(c) If it will not operate with constant foot throttle, remove the air cleaner, and check to see if fuel is getting to the carburetor. This is done by looking down the carburetor while operating the throttle. If gasoline is observed spurting from the accelerator pump discharge nozzle, the engine was either flooded or the fuel system has water in it.

(d) If no accelerator pump discharge is observed in the carburetor throat, loosen the fuel pump to fuel tank line at the fuel pump. Remove the fuel tank filler cap. If fuel runs out freely, the line is clear. If not, blow the line out with air pressure from the fuel pump end.

NOTE: *Check the flexible gas line for a collapsed condition.*

100% SATISFACTION GUARANTEED

BUY IT NOW!

Click Here To Order

PayPal American Express Discover/Novus MasterCard VISA

(e) If the cause of the trouble has not been found, check the fuel pump pressure, and repair or replace the fuel pump or carburetor.

(f) If the fuel system is operating correctly and the engine still stalls, it may be due to the coil or condenser breaking down under operating temperature. Check and replace as necessary.

(4) ENGINE CONTINUALLY MISSES AT IDLE. When the engine continually misses on the same cylinders, the fault generally lies in the ignition system.

(a) Isolate the miss by pulling one spark plug cable at a time from the plugs. Remove the plugs, then clean, inspect, and adjust them. Replace those that are badly fouled.

(b) Check the spark plug wires for signs of deterioration and replace as necessary.

(c) Remove the distributor cap and rotor, then clean and inspect them. Replace if necessary.

(d) If none of the above correct the condition, check the compression to determine if compression and intake manifold passages are satisfactory.

(5) ENGINE MISSES ERRATICALLY AT IDLE. This may be caused by a combination of things. Check the following in sequence:

(a) Carburetor (including choke operation), idle mixture setting, and float level.

(b) The ignition system starting with the spark plugs, if the carburetor adjustment does not eliminate the trouble. Make necessary repairs.

(c) The vacuum lines for leaks at all lines and fittings if the miss is still present. Make any necessary repairs.

(d) Valve operation and make a compression test if the miss persists.

(6) ENGINE MISFIRES OR HESITATES ON ACCELERATION. This malfunction is usually a combination of faults in the ignition and fuel system, but also can be caused by the exhaust system. Perform the following checks in the sequence given:

(a) Check the operation of the exhaust thermostat valve. If sticking, free up or replace as necessary.

(b) Check the paint on the intake manifold heat riser passage. If the paint is not burned off, the passage may be obstructed and the carburetor may not be vaporizing the gasoline properly.

(c) Remove the spark plugs, inspect, clean and re-gap. Check to verify that the plugs are of the proper heat range. Replace any plugs that are defective.

(d) Remove the distributor cap and check the point distributor shaft clearance, condition of cam lobes, and points. Make necessary repairs or replacements.

(e) Check the spark plug wires for signs of deterioration, and replace as necessary. Perform a spark plug check. Replace

(f) Check fuel pump pressure and adjust carburetor float level. Check accelerator pump action and linkage.

(g) If the problem still persists, take compression readings and check the valve action. Check the valve spring rates and assembled height. Repair or replace as necessary.

(7) ENGINE DOES NOT DEVELOP FULL POWER. Lack of power is usually caused by poor compression. However, some preliminary checks should be made. Make certain that the throttle opens all the way, that the choke remains open, and that the governor cut-off operates properly.

(a) After preliminary checks are made, check the compression. This should quickly indicate whether the internal components are operating properly.

(b) If the compression checks within limits, check the ignition system, including initial timing and distributor operation.

(c) If the compression, and ignition system, are satisfactory, check the fuel system, including carburetion and fuel pump pressure.

(d) If the problem still exists, a check of mechanical components must be made. Check the valve lash, lift, and timing. Repair or replace as necessary.

b. Fuel System.

The fuel system consists of the fuel tank, fuel pump, carburetor, and connecting lines. Dirt and other foreign material are a major source of fuel system problems, and all components should be kept as clean as possible.

(1) EXCESSIVE FUEL CONSUMPTION. Faulty carburetion is usually responsible for excessive fuel consumption. However, the following preliminary checks should be made. Check for fuel leaks in the system, check choke operation and adjustment, and make certain the accelerator linkage is free. Check to see if the brakes are dragging. Then adjust the carburetor.

(a) Verify the complaint with test equipment installed in the vehicle. Show the customer how improper operation of the vehicle will affect fuel consumption.

(b) If test shows fuel consumption to be excessive, remove the carburetor and rebuild. Since poor carburetion is usually a combination of internal malfunctions, it is usually not advisable to try to repair only one system in the carburetor. Time will be saved by a complete carburetor overhaul.

(2) CARBURETOR FLOODS. Make a visual inspection of the carburetor for leaking gaskets or casting defects. Tape the carburetor bowl. If the flooding stops, the needle was held open by foreign material. If the flooding persists, follow the steps below:

(a) Remove the air cleaner and check choke operation.

(b) Check the float level and the condition of the



carburetor float. Check the condition of the needle and seat. Replace if necessary.

(c) Check fuel pump pressure. If the pressure is excessive, the pump was forcing fuel past the float needle and should be rebuilt or replaced.

c. Cooling System.

The cooling system is thermostatically controlled to regulate engine operating temperature and provide for a short engine warm-up period.

(1) **ENGINE OVERHEATS.** Usually, engine overheating is the result of insufficient coolant supply. Check the coolant first. Make certain that the cause of trouble is not anti-freeze evaporation.

(a) If the supply is low, check for leaks in the cooling system, make repairs as necessary.

(b) Check the water pump belt for proper tension and adjust it if it is loose.

(c) Inspect the radiator fins for obstructions (bugs, dirt, etc.). Clean it if it is clogged.

(d) Using a thermometer in the radiator, check the gauge reading for accuracy.

NOTE: *Inaccurate readings are sometimes caused by insufficient clearance between the head casting and the temperature sending unit element. Repair or replace as necessary.*

(e) Check the thermostat for proper operation and heat range. If defective or of the wrong heat range, replace the thermostat.

(f) Check the ignition timing and adjust if necessary.

(g) Check the radiator for proper flow. Flush the radiator if necessary.

(h) Remove the water pump and check for a defective impeller or water passage obstruction. Repair or replace as necessary.

(2) **ENGINE FAILS TO REACH NORMAL OPERATING TEMPERATURE.**

Generally, this symptom is caused by the thermostat sticking or being of the wrong heat range. Check the thermostat first. If the engine still does not reach operating temperature, check the gauge and sending unit, with a thermometer in the radiator, for accuracy. Replace the defective unit.

2. ENGINE TUNE-UP

During the life of an automotive vehicle, it should receive regular maintenance and inspection services. In addition, to maintain satisfactory performance, an engine tune-up should be performed periodically.

Any type of engine test equipment may be used to make the tests outlined in the checking procedures. As the checks are performed, make a visual inspection of the wiring, vacuum hose, cooling system hose, heater hoses, etc.

a. Minor Tune-Up.

A minor tune-up consists of the following operations:

(1) **INSPECT IGNITION WIRES, BATTERY CABLES, AND CHECK THE CONDITION OF THE BATTERY.** Inspect all ignition cables for worn or damaged insulation. Make sure that the spark plug wires are firmly seated in the distributor cap and that the terminals and the terminal sockets are free from corrosion.

Inspect the battery case for cracks and leaks. Check the water level in the battery. Inspect the battery cable connections for corrosion and clean if necessary. Brush the cable connectors with grease to retard further corrosion, then tighten them.

(2) **TEST CYLINDER COMPRESSION.** Operate the engine until normal operating temperature is reached. Remove all spark plug wires and disconnect the distributor. Connect a compression tester, test the engine for at

least four compression strokes. Note the reading on the first full stroke as well as on the final stroke to determine if any variation exists. All cylinders should be tested the same number of strokes to assure accurate readings.

The compression of all cylinders should be uniform within ten pounds. Record the compression of each cylinder to indicate to the customer the internal condition of his engine.

A reading of more than ten pounds above normal indicates carbon or lead deposits in the cylinder.

A reading below normal indicates leakage at the rings, valves, or gasket.

(3) **CLEAN, ADJUST, AND INSTALL SPARK PLUGS.** Sandblast the spark plugs, wipe the porcelain clean, file the electrode tips flat and adjust the spark gap. Test the plugs in an approved spark plug tester. Replace any plugs that have broken or chipped porcelain, badly burned electrodes, or that do not check satisfactorily on the tester. Install the spark plugs and tighten them to the specified torque.

(4) **CHECK AND ADJUST TIMING AND INSPECT BREAKER POINTS.** Disconnect the vacuum line between the distributor and carburetor. Start the engine and operate it at idle speed. Check the timing with a timing light and make the necessary adjustments. Connect the distributor vacuum line after completing the adjustments and check ignition advance as the engine is accelerated. Inspect the distributor points for pits, excessive metal transfer, and burns. Replace points

which cannot be cleaned up by a light application of the point file.

(5) **CHECK ENGINE VACUUM AND ADJUST CARBURETOR IDLE.** Check the engine manifold vacuum at idle speed.

If the vacuum is lower than normal, check for leakage at the vacuum lines and intake manifold. Check the carburetor idle adjustment.

If the vacuum is still below normal or is erratic, it is an indication of bad rings, sticky valves, weak valve springs or leaky gaskets. If this condition exists, it should be reported to the customer.

Set the carburetor idle speed to specifications. Set the idle fuel adjustment to the point of highest and steadiest manifold vacuum and/or at the smoothest engine idle. Reset the idle speed if required.

(6) **CHECK GOVERNOR OPERATION — 256, 279, 317 CUBIC INCH ENGINE.** Connect a tachometer to the engine. Start the engine and gradually increase the throttle opening, observing the tachometer reading, until the no-load cut-off speed is reached. If the cut-off is not within the specified range, stop the engine and make the necessary adjustments. Repeat the test until the correct cut-off speed is obtained.

(7) **CLEAN AIR CLEANER AND FUEL PUMP BOWL.** Clean the air cleaner, and oil the element (dry-type). If the air cleaner is the oil bath-type, refill to the indicated level with engine oil of the specified viscosity.

Remove and clean the fuel pump bowl. Install a new filter in the 223, 239, and 256 cubic inch engines. Clean the filter in the 279 and 317 cubic inch engines. Install the sediment bowl and a new gasket.

b. Major Tune-Up.

A major tune-up consists of the following operations:

(1) **CLEAN AND INSPECT BATTERY CABLES.** Remove the cables from the battery. Clean the battery terminals and cable connectors. Inspect the battery case for cracks and leaks. Fill the battery to the proper water level. Replace deteriorated connectors, and cables that are shorted or have worn insulation. Brush the cable connectors with grease to retard corrosion. Connect the cables to the battery.

(2) **TEST CHARGING SYSTEM.** Test the battery and recharge or replace if necessary to insure dependable service. Check the generator output and the regulator. Repair or replace a faulty generator. Adjust or replace the regulator if necessary.

(3) **TEST CYLINDER COMPRESSION.** Follow the procedure under “a. Minor Tune-Up”.

(4) **CHECK CYLINDER HEAD AND MANIFOLD BOLTS.** Tighten the bolts to the higher specified limit. If the bolt torque is more than 20 foot-pounds below the lower specified limit, replace the head gasket. Tighten the intake and exhaust manifold bolts and nuts to 23-28 foot-pounds torque.

limit, tighten the bolt to the higher specified limit. If the bolt torque is more than 20 foot-pounds below the lower specified limit, replace the head gasket. Tighten the intake and exhaust manifold bolts and nuts to 23-28 foot-pounds torque.

(5) **CLEAN, ADJUST, AND INSTALL SPARK PLUGS.** Sandblast the spark plugs, wipe the porcelain clean, file the electrode tips flat, and adjust the spark gap. Test the plugs in an approved spark plug tester. Replace any plugs that have broken or chipped porcelain, badly burned electrodes, or that do not check satisfactorily on the tester. Install the spark plugs and tighten them to the specified torque.

(6) **TEST DISTRIBUTOR.** Test the distributor vacuum advance on a suitable distributor test stand, and make adjustments, repairs, or replacements as required. Set the distributor point dwell to specifications. Apply a light coat of distributor cam grease to the cam.

(7) **CLEAN AND INSPECT THE DISTRIBUTOR CAP.** Inspect the distributor cap for cracks or other damage. Terminal housing sockets should be free from corrosion.

(8) **TIME IGNITION.** Before connecting the vacuum line between the distributor and carburetor, start the engine and operate it at idle speed. Check the timing with a timing light and make the necessary adjustments. Connect the distributor vacuum line after completing the adjustment and check ignition advance as the engine is accelerated.

(9) **CHECK IGNITION PRIMARY CIRCUIT.** Check the primary circuit amperage with a suitable test machine. The amperage draw with the engine stopped should be 5.0 to 5.5 amps. With the engine operating at idle speed, the amperage draw should be 2.75 to 3.0 amps. Inspect the wires visually for faulty insulation and poor connections.

(10) **TEST SPARK INTENSITY.** Determine if the spark from each spark plug wire will jump a 3/16-inch gap.

If the spark is unsatisfactory at all spark plugs, trouble exists in the coil, condenser, secondary wiring, rotor or cap, internally in the distributor, or in the external primary circuit.

If the spark is unsatisfactory at some but not all of the spark plug wires, the trouble is in the wire itself, the wire is not seated in the housing socket, or the distributor cap is shorted.

(11) **CHECK AND ADJUST VALVE LASH.** Check and adjust the valve lash after the engine is thoroughly warmed up.

(12) **TEST FUEL PUMP PRESSURE AND CAPACITY.** Check the fuel pump pressure. The pressure should be within 4 to 5 p.s.i. at 900 r.p.m. for the 223, 239, and 256 cubic inch engines and 3.5 to 4.5 p.s.i. at 900 r.p.m. for the 279 and 317 cubic inch engines.



The fuel pump capacity on all engines should be 1 pint in 45 seconds or less.

(13) **INSPECT AND CLEAN FUEL PUMP BOWL.** Remove and clean the fuel pump bowl. Install a new filter on the 223, 239, or 256 cubic inch engine. Clean the filter on the 279 or 317 cubic inch engine. Install the sediment bowl and a new gasket.

(14) **CLEAN CARBURETOR.** Clean the carburetor fuel bowl. Set the float or fuel level, and check the accelerator pump operation.

(15) **CLEAN AIR CLEANER.** Clean the air cleaner, oil the element (dry-type), and install. If the air cleaner is the oil bath-type, fill to the indicated level with engine oil of the specified viscosity.

(16) **TEST ENGINE VACUUM.** Check the engine manifold vacuum at idle speed.

If the vacuum is lower than normal, check for leakage at the vacuum lines and intake manifold. Check the carburetor idle adjustment.

If the vacuum is still below normal or is erratic, it is

an indication of bad rings, sticky valves, weak valve spring, or leaking gaskets. If this condition exists, it should be reported to the customer.

(17) **ADJUST CARBURETOR IDLE.** Connect a vacuum gauge, and set the idle speed to specifications with a tachometer installed on the engine. Set the idle fuel adjustment to the point of highest and steadiest manifold vacuum and/or at the smoothest engine idle. Reset the idle speed if required.

(18) **CHECK DEPOPPER OPERATION.** Check the operation of the carburetor depopper valve on the 256, 279, and 317 cubic inch engines.

(19) **CHECK GOVERNOR OPERATION — 256, 279, AND 317 CUBIC INCH ENGINES.** Follow the procedure under “a. Minor Tune-Up.”

(20) **ROAD TEST.** Road test the vehicle as a final check on the work performed. Also, notice the performance of the transmission, axle, brakes, and any optional accessories. Recommend any additional service required when the vehicle is delivered to the owner.

3. ENGINE REMOVAL AND INSTALLATION

Engine removal and installation procedures are separated according to the various truck body styles. A separate procedure is given for Conventional and Cab Forward Trucks equipped with Fordomatic.

The engine mounts used to install the engines on a work stand are illustrated in figs. 1, 2, and 3.

a. Conventional Truck.

The engine removal and installation procedure for the conventional truck also applies to the school bus.

(1.) **REMOVAL.** Drain the cooling system. Drain the crankcase. Remove the hood. Remove the fan assembly and the fan belt. Disconnect the heater hoses at the engine. Remove the radiator and shroud assembly.

NOTE: *On trucks equipped with an air compressor open the air reservoir drain cock. Loosen the fitting at the reservoir inlet line. Disconnect the air line and clip at the front of the engine, then lay the line against the engine side compartment.*

Remove the air cleaner, then tape the carburetor air horn closed.

Disconnect the windshield wiper vacuum hose at the manifold.

Disconnect the hand throttle control, choke cable, accelerator rod, and the accelerator retracting spring at the carburetor.

Disconnect the engine temperature sending unit wire,

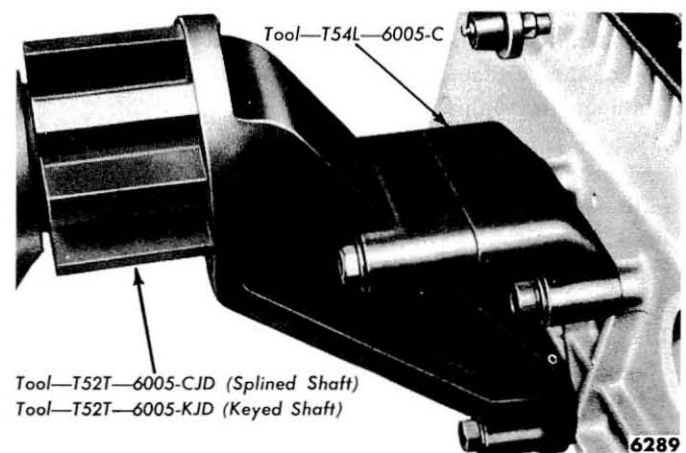

Fig. 2—Engine Mount Adapter—223 Cubic Inch Engine

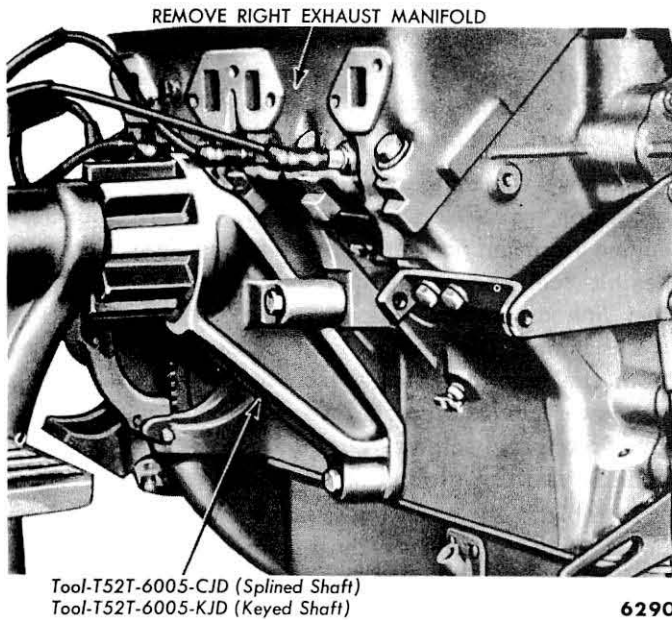

Fig. 3—Engine Mount—279 or 317 Cubic Inch Engine

the oil pressure sending unit wire, and the ignition coil primary wire. Disconnect the generator wires.

Disconnect the flexible fuel line at the fuel pump.

Disconnect the muffler inlet pipe at the exhaust manifold.

Disconnect the clutch release lever retracting spring. Disconnect the starter cable at the starter, then disconnect the battery ground strap at the engine. Remove the starter assembly. Install the engine lifting sling as shown in figs. 4 or 5.

Remove the flywheel housing to engine bolts. Remove the flywheel housing lower cover.

Remove the bolts from the engine front support.

Take up the weight of the engine with a hoist. Support the transmission with a jack, then move the engine forward to separate the clutch from the transmission input shaft. Lift the engine carefully from the chassis. Do not allow the engine to damage the front end sheet metal.

Install the engine on a work stand using the appropriate mount. Remove the lifting sling.

NOTE: *On vehicles equipped with a 279 or 317 cubic inch engine, lower the engine on blocks, then remove the right-hand manifold. Install the engine mount adapter. Install the engine lifting sling, then raise the engine and install it on the work stand (fig. 3).*

(2) **INSTALLATION.** Install the engine lifting sling, take up the weight of the engine with a hoist, then remove the engine from the work stand.

with a 279 or 317 cubic inch engine from the work stand, then install the right-hand manifold and the engine lifting sling.

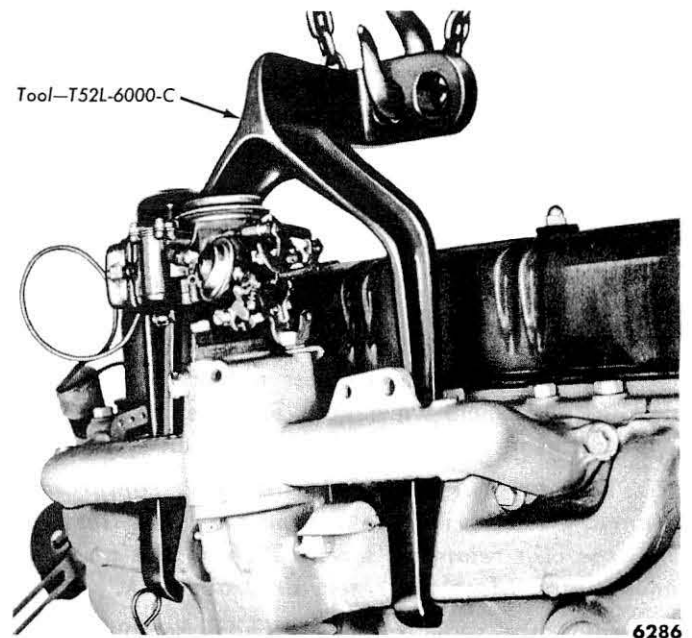

Fig. 4—Lift Bracket—6-Cylinder Engine

Install the engine in the chassis, aligning the transmission input shaft with the clutch disc and pilot bearing.

NOTE: *After the transmission input shaft enters the clutch disc, it may be necessary to place the transmission in gear and rotate the crankshaft to align the clutch disc splines with the main drive gear splines.*

Install the flywheel housing to engine bolts, and tighten the bolts to specifications. Install the housing lower cover. Install and tighten the engine front support

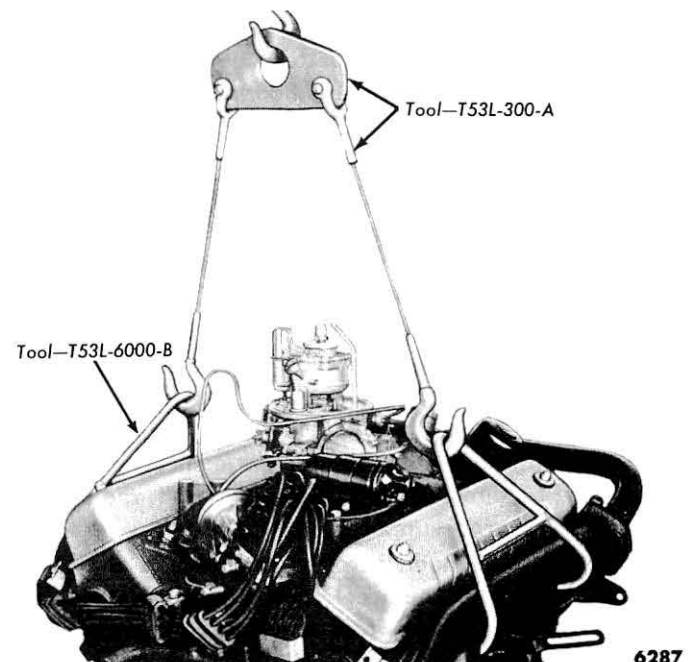

Fig. 5—Lifting Sling—8-Cylinder Engine

100% SATISFACTION GUARANTEED

BUY IT NOW!

Click Here To Order

PayPal American Express Discover MasterCard VISA

bolts. Remove the engine lifting sling. Install the starter assembly. Connect the starter cable and the ground strap. Connect the clutch release lever retracting spring.

Position the muffler inlet pipe on the manifold flange, install the lockwasher and nuts, then tighten the nuts to specifications.

Connect the fuel line. Connect the generator wires, the engine temperature sending unit wire, the oil pressure sending unit wire, and the ignition coil primary wire.

Connect and adjust the throttle control and choke control. Connect the accelerator rod and spring. Connect the windshield wiper hose. Remove the tape from the carburetor, and install the air cleaner.

NOTE: On trucks equipped with an air compressor, connect the reservoir to compressor line, then install the clip retaining screw. Tighten the reservoir inlet fitting. Close the reservoir drain cock.

Position the radiator and shroud assembly in the vehicle, and install the retaining bolts. Connect the radiator and heater hoses. Install the fan assembly and belt and the air compressor belt (if used), then adjust the belt tension. Install the hood. Fill the cooling system. Fill the crankcase with the proper grade and quantity of engine oil. Run the engine until it reaches normal operating temperature, then check for coolant and oil leaks.

b. Cab Forward Truck.

The following procedure applies to all engines.

(1) **REMOVAL.** Raise the hood. Drain the cooling system. Drain the crankcase. Disconnect the throttle return spring.

Remove the floor mat. Remove the battery cover, and disconnect one of the battery cables to break the electrical circuit. Remove the floor pan.

Disconnect the ignition coil primary wire. Disconnect the ground wire at the coil mounting bracket.

Remove the screws securing the loom clip, taillight wire clip, and speedometer cable, then move the wires and speedometer cable out of the way. Remove the distributor cap and rotor.

Remove the fan assembly and belt. Remove the air cleaner, and tape the carburetor air horn closed. Disconnect the radiator upper and lower hoses. Disconnect the heater hoses at the engine.

Remove the upper and center grille sheet metal. Remove the radiator, shroud assembly, and radiator to front fender apron supports.

Disconnect the hand throttle control and the choke cable. Remove the manifold (or air compressor,

vent the air compressor drain cock. Remove the air compressor. Remove the clip retaining the air line to the front end of the right hand cylinder bank, loosen the fitting at the reservoir end of the line then lay the line back against the engine side compartment.

Remove the temperature sending unit wire, and the generator wires. Remove the oil dipstick. Remove the engine front support nuts and washers. Disconnect the flexible fuel line at the fuel pump. Close off the main fuel line to prevent loss of fuel.

Disconnect the muffler inlet pipe, and pull it away from the manifold flange. Remove the flywheel housing lower cover. Remove the flywheel housing to engine retaining screws. Disconnect the starter cable and the battery ground strap. Remove the starter.

Install the engine lifting sling as shown in fig. 5. Position a floor jack under the engine, and place a wood block between the jack and the oil pan. Raise the engine slightly, and remove the front support bolts and rubber pad. Raise the engine carefully with a hoist, move it forward to clear the transmission input shaft, and remove it from the chassis. Mount the engine on a work stand using the appropriate adapter. Remove the engine lifting sling.

NOTE: On vehicles equipped with a 279 or 317 cubic inch engine, lower the engine on blocks, then remove the right-hand manifold. Install the engine mount adapter. Install the engine lifting sling, then raise the engine and install it on the work stand (fig. 3).

(2) **INSTALLATION.** Install the engine lifting sling, take up the weight of the engine with a hoist, then remove the engine from the work stand.

NOTE: On vehicles equipped with a 279 or 317 cubic inch engine, remove the engine from the work stand and lower it on blocks. Install the right-hand manifold. Install the engine lifting sling.

Lower the engine carefully into the engine compartment until it rests on the floor jack. Align the clutch disc and pilot bearing with the transmission input shaft, then slide the engine in until it contacts the flywheel housing.

NOTE: After the transmission input shaft enters the clutch disc, it may be necessary to place the transmission in gear and rotate the crankshaft to align the clutch disc splines with the main drive gear splines.

Lower the engine on the front support, and install the washers and nuts. Remove the engine lifting sling.

Install the flywheel housing to engine screws, and tighten the screws to specifications. Install the housing lower cover. Install the starter. Connect the starter cable and the battery cable.

Position a new gasket and the muffler inlet pipe on

100% SATISFACTION GUARANTEED

BUY IT NOW!

Click Here To Order

PayPal American Express Discover MasterCard VISA

the manifold. Install the lockwashers and nuts, and tighten the nuts to specifications.

Connect the engine temperature sending unit wire, the oil pressure sending unit wire, and the generator wire. Install the dipstick.

Connect the accelerator linkage. Connect and adjust the choke and throttle controls, then connect the windshield wiper vacuum hose. Connect the flexible fuel line.

NOTE: *On trucks equipped with an air compressor, install the compressor, connect the compressor lines, and install the air line clip retaining screw. Tighten the reservoir inlet fitting. Close the reservoir drain cock.*

Install the radiator to front fender apron support, the radiator and shroud assembly. Install the center and upper grille sheet metal.

Connect the radiator hoses and the heater hoses. Remove the tape from the carburetor, and install the air cleaner.

Connect the ignition coil primary wire and the ground wire. Position the loom clip, taillight wire clip, and speedometer clip, and install the retaining screws. Install the distributor rotor and cap.

Install the floor pan. Connect the battery cable, install the cover, then install the floor mat. Connect the throttle return spring.

Fill the cooling system. Fill the crankcase with the proper grade and quantity of engine oil. Run the engine until it is thoroughly warmed, and check for oil and coolant leaks.

c. Fordomatic—Conventional and Cab Forward Trucks

The following procedure covers the units equipped with Fordomatic.

(1) **REMOVAL.** To remove the engine from Fordomatic equipped vehicles, perform the steps outlined for the appropriate vehicle in the preceding paragraphs, in addition to the following steps:

Disconnect the transmission oil to water cooler inlet and outlet tubes.

Remove the upper screws retaining the converter housing to the engine. Remove the converter housing to engine lower screws. Remove the converter housing lower access cover, then using the tool illustrated in fig. 6, turn the flywheel till the flywheel drive plate is in position so that the three bolts can be removed. Turn the flywheel 180°, and remove the other three bolts. The Fordomatic flywheel drive plate is shown in fig. 7.

Remove all the engine lifting sling and remove the engine

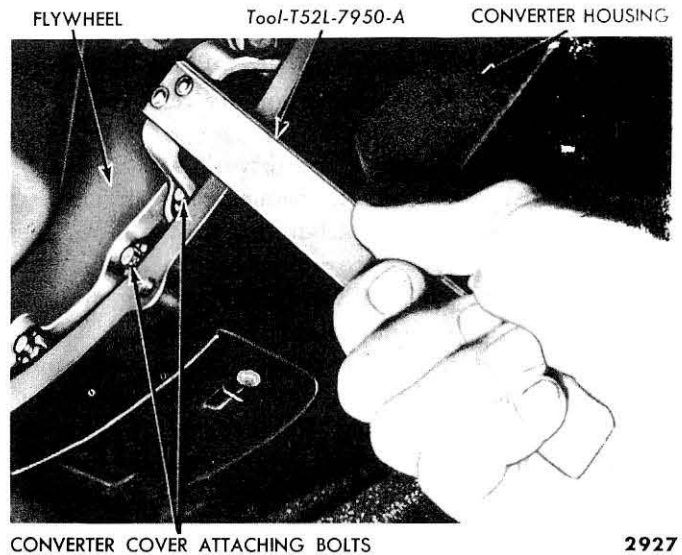

Fig. 6—Flywheel Drive Plate Removal

supports. Install the converter housing to engine upper bolts. Tighten the bolts finger tight. Install the front support washers and nuts. Remove the engine lifting sling.

Install the converter housing to engine lower bolts, and tighten the bolts to 40-45 foot-pounds torque. Install the six converter to flywheel drive plate bolts. Install the converter housing lower access cover.

Tighten the converter housing to engine upper bolts to 40-45 foot-pounds torque. Install the floor pan and the floor mat.

Connect the transmission oil to water cooler inlet and outlet tubes.

Proceed with the remainder of the engine installation in the manner prescribed for the individual vehicle.

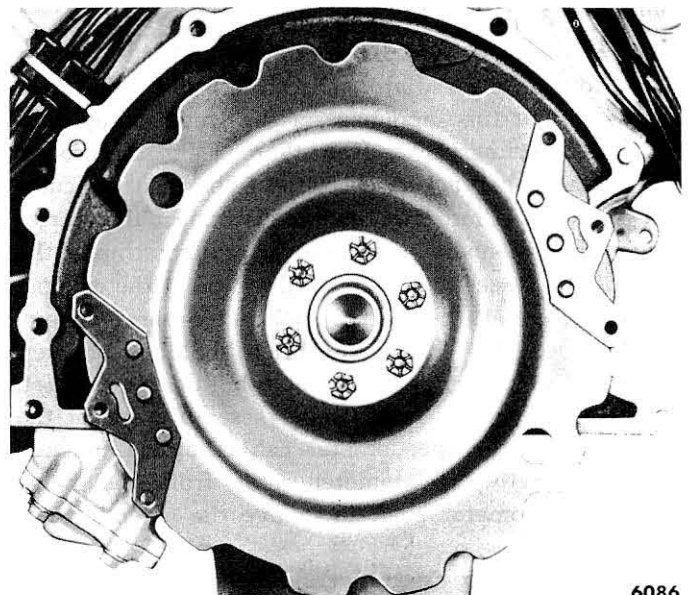

Fig. 7—Fordomatic Flywheel Drive Plate

100% SATISFACTION GUARANTEED

BUY IT NOW!

Click Here To Order

PayPal American Express Discover MasterCard VISA

Remove the engine in the manner prescribed for the converter pilot engine on the front

d. Parcel Delivery

The following procedure applies to all parcel delivery trucks. The engine and transmission are removed as an assembly.

(1) **REMOVAL.** Remove the driver's seat and support. Drain the crankcase. Disconnect the air cleaner tube and elbow from the carburetor, then remove the air cleaner from the engine cover bracket. Tape the carburetor air horn closed. Drain the cooling system. Remove the clutch pedal plate. Remove the brake pedal pad, then remove the pedal opening plate and slide it over the brake pedal rod. Remove the rubber mat from the pedal opening. Remove the two screws retaining the dimmer switch, and drop the switch through the floor board. Disconnect the accelerator rod from the pedal. Remove the left floor plate (the accelerator pedal and engine front cover hood lock are removed with the floor plate). Remove the master brake cylinder inspection cover. Remove the ten screws from the engine cover base plate. Remove the nuts and bolts retaining the center floor plate to the engine cover base plate. Loosen the three bolts securing the cross member reinforcing plate to the left and right wheel housings.

NOTE: *Drive a wedge between the reinforcing plate and the left and right wheel housings.*

Remove the center floor plate, then remove one reinforcing plate to cross member bolt from each end of the body cross member. Remove the engine cover and base plate assembly.

Disconnect the windshield wiper vacuum line at the fuel pump, and the fuel flex line at the tank fuel line.

NOTE: *On Fordomatic equipped vehicles disconnect the transmission selector rods at the transmission.*

Disconnect the radiator lower hose and the radiator upper hose at the radiator. Disconnect the radiator to cylinder outlet tube and hose at the water pump. Disconnect the primary wire from the coil and the ground wire at the coil bracket. Disconnect the heat indicator and oil pressure indicator wires. Disconnect the starter cable at the solenoid and the starter ground strap at the starter. Disconnect the exhaust inlet pipe at the exhaust manifold. Remove the emergency brake cable clevis pin, then remove the emergency brake holding bracket. Remove the emergency brake cable hold down bracket. Push the emergency brake cable assembly out of the way. Remove the speedometer cable holding bracket, then remove the speedometer cable from the transmission. Remove the speedometer gear and move the assembly out

Disconnect the
s member. Dis-
or.

Remove the engine front support bolts. Remove the rear support mount bolts and lower the right and left-hand pads.

Remove the universal joint "U" bolts and drop the rear of the drive shaft. Disconnect the universal joint knuckle dust cap. Remove the drive shaft spline from the universal joint knuckle and plug assembly.

Remove the carburetor inlet fitting and fuel line from the carburetor.

Remove the valve rocker arm cover, then install the appropriate engine lifting bracket. Position the hoist through the right door and attach it to the lifting bracket. Lift the engine and remove the engine and transmission as an assembly through the front door.

(2) **INSTALLATION.** Attach the engine lifting sling and hoist. Install the bolts in the engine block mounting holes. Position the engine in the truck through the right door.

NOTE: *Position the engine through the door transmission first. Connect the exhaust outlet pipe as the engine is lowered into position.*

Install the rear mount pads and bolts.

NOTE: *Keep the engine hoist attached to the engine so the transmission will rest lightly on the cross member. Line up the holes and install the bolts.*

Install the engine front support bolts, then lower the engine on the mounts and tighten the support bolts. Tighten the rear mount bolts, then safety wire the bolts. Remove the hoist and engine lifting bracket. Install the rocker arm cover. Install the carburetor inlet line and fitting.

Install the drive shaft spline in the universal joint knuckle and plug assembly. Connect and tighten the universal joint knuckle dust cap and seal. Connect the drive shaft and "U" bolts to the rear universal joint.

Connect the choke cable and generator wires. Install the fan assembly and belt. Install the speedometer cable and emergency brake cable and bracket. Connect the exhaust inlet pipe, the starter cable, heat indicator wires, oil pressure indicator wires, engine ground wires, and coil primary wire. Connect the radiator to cylinder outlet tube and hose, radiator lower hose, and the radiator upper hose. Connect the fuel flexible line and windshield wiper vacuum line.

NOTE: *On Fordomatic equipped vehicles, connect the transmission selector rods.*

Fill the crankcase with the proper grade and quantity of engine oil. Position the body cross member, then install the cross member bolts. Position the engine cover and base plate. Install the cross member to reinforcing plate lower bolts. Position the floor panel, then install the bolts securing the floor panel to engine cover base



plate. Install the floor panel screws. Install the bolts securing the cross member support to the right and left wheel housing. Install the engine cover base plate screws. Install the sheet metal cover between the engine cover and dash panel. Install the master brake cylinder inspection plate.

Install the left floor plate. Connect the accelerator rod and dimmer switch. Position the rubber mat over the

brake pedal opening, then install the pedal opening plate and pad.

Fill the radiator. Remove the tape from the carburetor air horn. Start the engine and check for coolant and oil leaks.

Install the air cleaner to engine cover bracket, then install the air cleaner and tube. Install the operator's seat and bracket.

4. INTAKE AND EXHAUST MANIFOLDS

The following inspection procedures are applicable to new and used manifolds.

a. Cleaning and Inspection.

Remove the manifolds. Wash grease, oil, and dirt from the outside of the manifold. Clean the inside of the manifold with a round, bristle brush attached to a flexible wire handle. Dry with compressed air.

Inspect the mating flanges of the intake manifolds for cracks, nicks, burrs, or scratches. Check the flatness of these surfaces as indicated in fig. 8. Check the fuel-air passages and the heat riser for restrictions. Check the manifold openings for proper alignment with their respective cylinder head ports. Improper alignment may result in a loss of power. Inspect the entire manifold for cracks or visible casting defects which would make it unfit for further service.

Inspect the exhaust manifold for burned out spots, cracks, and/or weak sections.

b. Repairs.

Dress nicked or warped mating surfaces on a surface plate. Minor nicks, burrs, or scratches may be removed with a file.

Remove all obstructions from intake manifold passages. Replace cracked or severely warped manifolds,

and those manifolds which contain unremovable obstructions.

Replace defective exhaust manifolds.

CAUTION: Remove all filings and foreign matter that may have entered the manifold as a result of repair work.

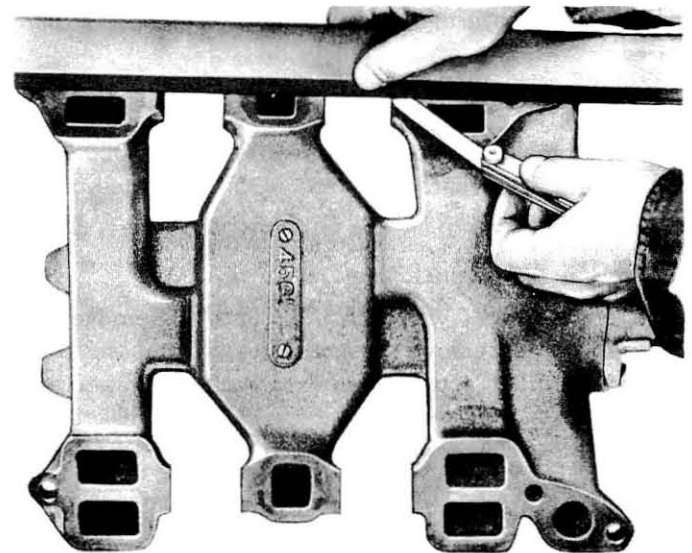

Fig. 8—Checking Flatness of the Intake Manifold Mounting Flanges

5. ROCKER MECHANISM, CYLINDER HEAD, VALVES, VALVE LASH ADJUSTMENT, AND VALVE TIMING

This section covers the inspection and repair procedures applicable to the rocker mechanism, cylinder head, and valves. In addition, the methods used to check valve timing are given.

a. Rocker Mechanism.

(1) **CLEANING AND INSPECTION.** Remove and disassemble the rocker mechanism. Check the I. D. of the rocker arm bore and the O. D. of the rocker arm arms, against specifications. Make sure the rocker arms are free of scuffs, nicks, or scratches. Check the adjusting screws and

lock nuts for stripped or broken threads, and the ball end of the screw for nicks and scratches. Make sure the adjusting screws turn freely in the rocker arms.

Inspect the locating springs for cracks or other signs of failure.

Inspect the oil drain tube for cracks or sharp bends.

Check the push rods between ball and cup centers with a dial indicator for conformance to specifications (fig. 9). Check the ball end and socket end of the push rods for nicks, grooves, or roughness.

NOTE: A rough check for bent push rods can be made while they are installed in the engine by rotat-

100% SATISFACTION GUARANTEED

BUY IT NOW!

Click Here To Order

PayPal American Express Discover/Novus MasterCard VISA

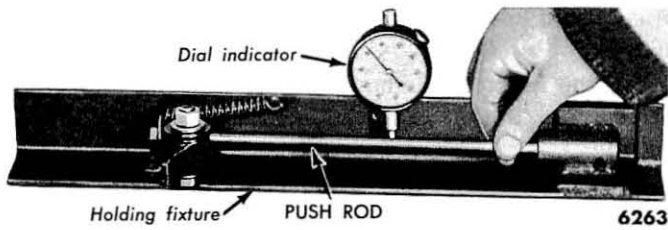

Fig. 9—Push Rod Runout Check

ing them (valve closed) and observing the runout. If any runout is observed, be sure to check the rod between centers as described above.

(2) **REPAIRS.** If the clearance between the shaft and rocker arms exceeds 0.004-inch, replace the shaft and/or the rocker arms. Replace all rocker arms that have severely scored or scuffed bores and/or grooved pads. Replace all severely scored or scuffed rocker shafts. Dress up minor nicks or scratches. Replace all damaged rocker arm lock nuts, adjusting screws, and springs.

Replace the oil drain tube if it is cracked or has a sharp bend.

If the total runout of a push rod exceeds 0.020 inch, at any point, discard the rod. Do not attempt to straighten push rods.

b. Cylinder Head.

(1) **CLEANING AND INSPECTION.** Remove the cylinder head. Remove carbon deposits from the combustion chamber and valve heads with a scraper and a wire brush. Be careful not to scratch the gasket surface. Clean the gasket surface with solvent to remove any gasket sealer.

Check the head for cracks. Check the gasket surfaces for flatness (fig. 10). Check to see that all water passages are open. Make sure the gasket surfaces of both head and block are free from burrs or scratches. Check the intake port mating surfaces for flatness as shown in fig. 11.

Check the cylinder head core plug for evidence of leakage.

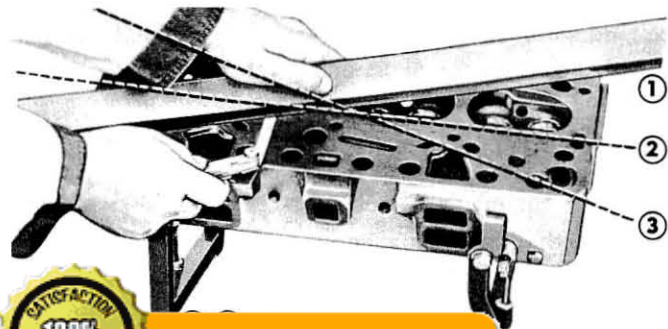

Cylinder Head

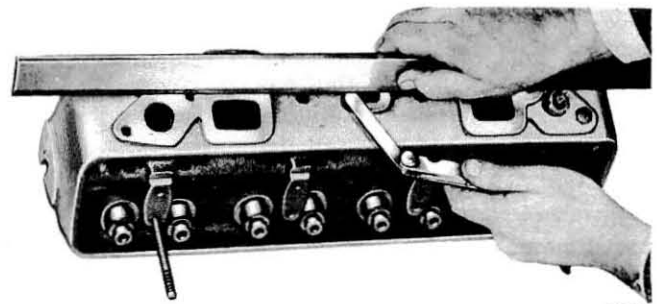

Fig. 11—Checking Flatness of the Intake Port Mating Surfaces

(2) **REPAIRS.** Remove all burrs or scratches with an oil stone. Replace the head if it is cracked.

If the cylinder head core plug leaks, replace it as indicated for the particular engine.

c. Valve Mechanism.

The two types of valve assemblies used in the truck engines are the rotating-type (fig. 12) and the free-turning-type (fig. 13). Table 1 lists the valve types peculiar to each engine. Those engines incorporating umbrella-type valve stem seals are also designated in Table 1.

Valve guides are made integral with the cylinder heads. Valves with oversized stems are available as replacements if it becomes necessary to ream the valve guides.

(1) **CLEANING AND INSPECTION.** Before removing the valve assemblies from the cylinder heads, perform a cylinder head leak test to determine if the valves are seating properly. Turn the cylinder head on its side and pour solvent into the ports. If the solvent leaks past the valve seats, the valves are not seating properly.

Disassemble the cylinder head. Discard umbrella-type valve stem seals, and replace with new seals. Scrape and/or wire brush carbon from the head and stem of the valves. Remove varnish from the valve stems. Carefully clean all carbon from the valve seat with a wire brush.

Table 1—Valve Parts Peculiar to Each Engine

Engine (Cubic Inch)	Umbrella Seals		Rotating Valves		Free Turning Valves
	Int.	Exh.	Int.	Exh.	Exh.
223	Yes	Yes	Yes	Yes	
239	Yes	Yes	Yes	Yes	
256	Yes		Yes		Yes
279	Yes		Yes		Yes
317	Yes		Yes		Yes

100% SATISFACTION GUARANTEED

BUY IT NOW!

Click Here To Order

PayPal | American Express | Discover | MasterCard | VISA

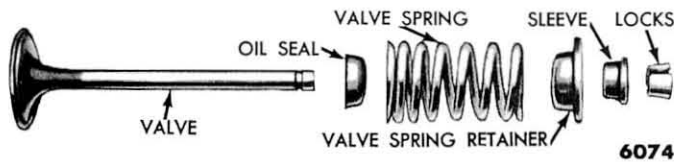

Fig. 12—Rotating-Type Valve Assembly

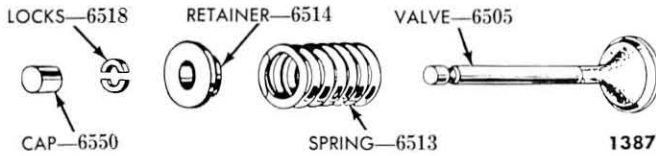

Fig. 13—Free Turning-Type Valve Assembly

Check the valve for evidence of imperfect seating, heavy discoloration, burning or erosion, or evidence of warpage. Check the valve face runout (fig. 14), and also check the face for pits and grooves. Inspect the ends of the valve stem for grooves or scores.

Inspect the valve springs for cracks or other signs of failure. Make sure the ground surface of the spring is flat. Check the valve spring pressure (fig. 15) and the valve spring free length.

Check the valve spring retainers for wear or signs of failure. Check the tapered seat where the valve locks in the retainer. These locks are split, and wear may be noted by ridges left between the halves of the locks.

Check the exhaust valve seat insert (256, 279, and 317 cubic inch engines) for looseness or signs of excessive wear.

Check the I. D. of the valve guides (fig. 16) and the O. D. of the intake and exhaust valve stems (fig. 17)

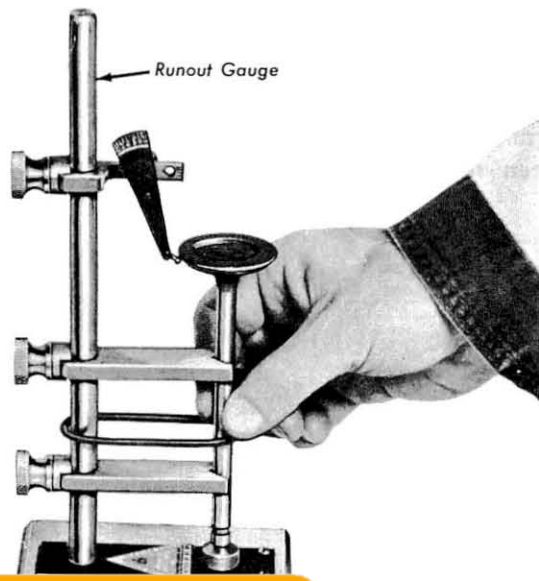

6266

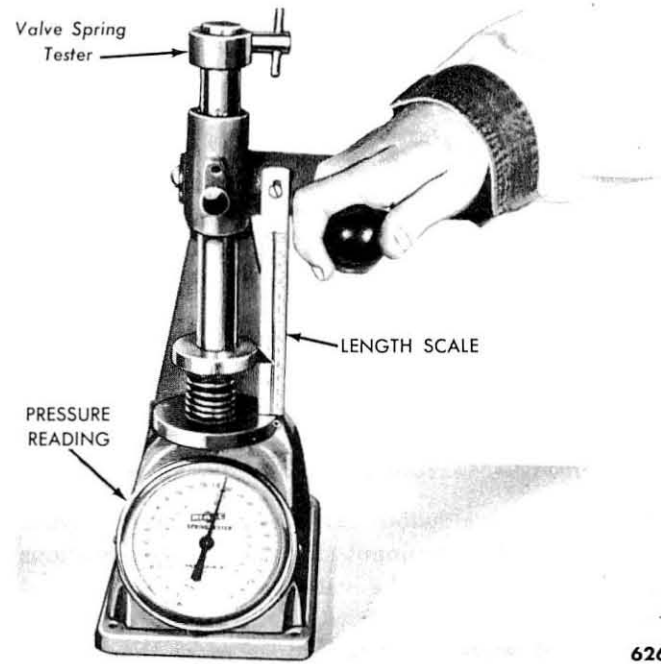

Fig. 15—Valve Spring Pressure Check

against specifications. If the clearance is not within limits, and the diameter of the valve stem is on the lower limit, select a new valve with a stem diameter on the upper limit. If the clearance is still not within limits, ream the valve guide (fig. 18) for the next oversize valve stem.

Check the valve seat runout and the valve seat width as shown in figs. 19 and 20.

Discard any defective valves, springs, locks, or retainers.

(2) **REFACING VALVES.** Grind the valve face at a 45° angle on a valve grinder (fig. 21). Grind off only enough stock to remove pits and grooves from the valve face.

If the edge of the valve head is less than $\frac{1}{32}$ -inch after grinding, replace the valve.

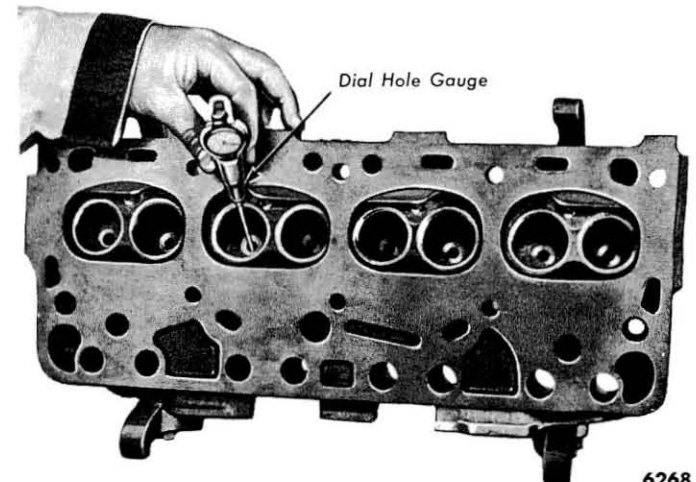

6268

Fig. 16—Measuring I.D. of the Valve Guide

**BUY IT NOW!****Click Here To Order**

Check



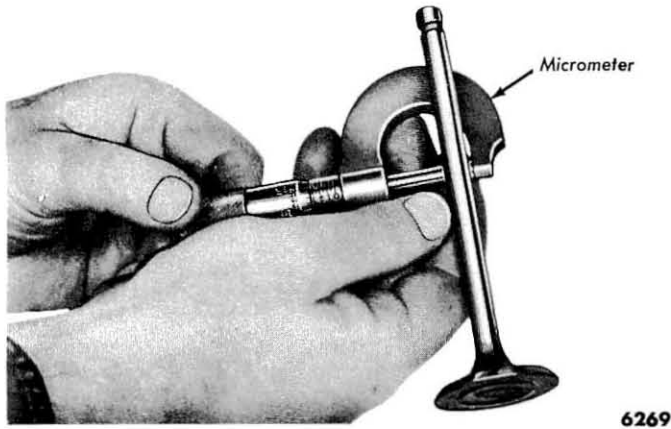

Fig. 17—Measuring O.D. of Valve Stem

If the valve face runout exceeds specifications, grind the valve face. If the runout still exceeds specifications after grinding, discard the valve.

Grind all grooves or score marks from the valve stem ends. However, do not remove more than 0.010-inch from the end of the stem.

(3) **REFACING VALVE SEATS.** Grind the valve seat with a grinder (fig. 22). Remove only enough stock to clean up pits or grooves in the seat. If the valve seat width exceeds specifications (figs. 23 or 24), remove just enough stock from the top and bottom edge of the seat to reduce the width. Use a 30° angle wheel to remove stock from the bottom of the seat and a 60° angle wheel to remove stock from the top. Keep the seat as near to the center of the valve face as possible.

After refacing valves and seats, it is good practice to lightly lap in the valves with a medium grade lapping compound, to match the seat and the valve.

(4) **VALVE SEAT INSERT REPLACEMENT.** To remove the exhaust valve insert from the 256, 279,

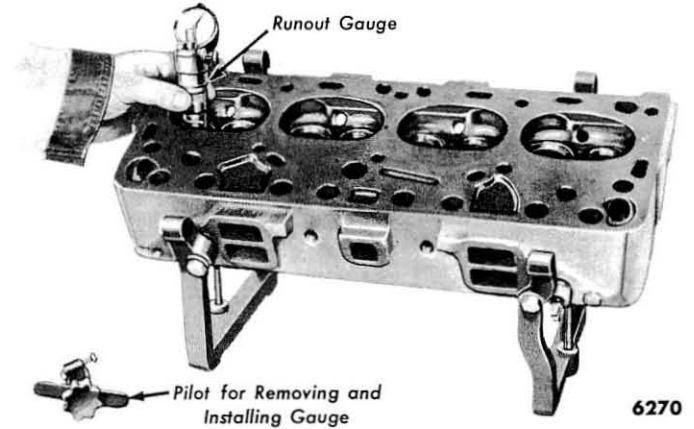

Fig. 19—Valve Seat Runout Check

and the 317 cubic inch engines, invert the head and insert a drift through the exhaust valve port, then drive the seat out.

Counterbore the insert recess to specifications in the manner shown in fig. 25. Cut slightly (0.001-0.002 inch) below the old counterbore depth to clean up this face. Clean out chips and all oil from the recess.

Chill the oversize insert and the installation tool in dry ice for ½-hour. Position the insert on the tool with the small radius on the outer edge facing outward. Pilot the driving tool in the valve guide, then drive the insert into the counterbore until it is fully seated. Do notpeen the area around the insert. Reface the new valve seat insert.

CAUTION: *The installation of the insert must be performed immediately on removal of the tool and insert from the dry ice. Protect the hands with gloves when handling the chilled insert and tool.*

d. Valve Lash Adjustment.

Valve lash is adjusted by means of the set screw and lock nut located on the push rod end of the rocker arm. If the cylinder head or the rocker mechanism has been removed and installed, it will be necessary to

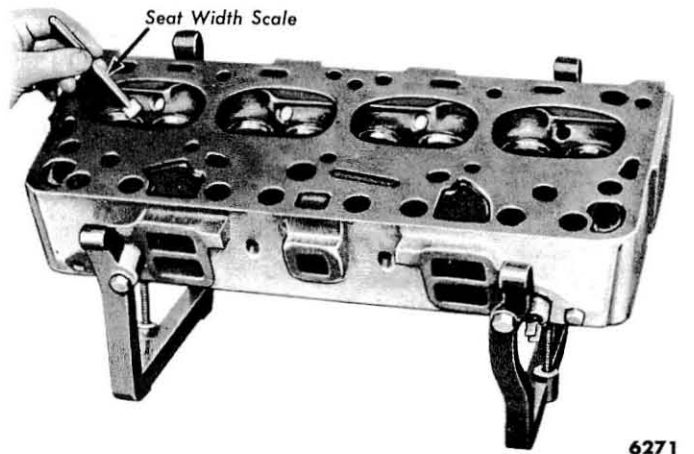

Fig. 20—Measuring Valve Seat Width

100% SATISFACTORY GUARANTEED

BUY IT NOW!

Click Here To Order

PayPal, American Express, Discover, MasterCard, VISA

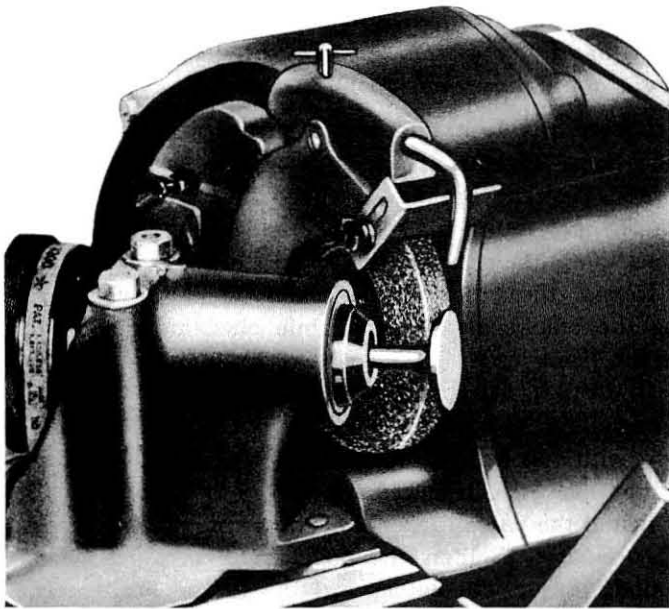

Fig. 21—Refacing Valves

make a preliminary adjustment before starting the engine. If the valve lash adjustment is made for the purpose of engine tune-up, omit step (a) and proceed with step (b) under the procedure for the applicable engine.

(1) 6-CYLINDER ENGINE.

(a) PRELIMINARY ADJUSTMENT. Remove the valve rocker arm cover. Rotate the crankshaft until No. 1 piston is near top dead center (T.D.C.) at the end of the compression stroke.



6272

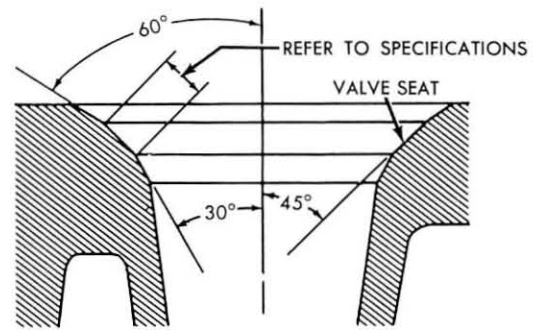

Fig. 23—Valve Seat Width

NOTE: No. 1 piston is near T.D.C. at the end of the compression stroke when both valves are closed and the timing mark on the crankshaft damper is in line with the pointer.

Check the intake and exhaust valve lash for No. 1 cylinder with a feeler gauge (fig. 26). If the lash is not to specifications, loosen the adjusting screw until this clearance is obtained. Tighten the lock nut without moving the adjusting screw.

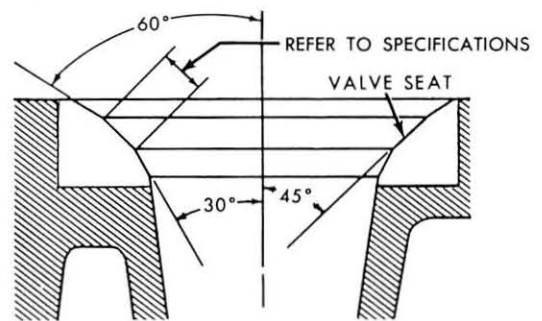

Fig. 24—Exhaust Valve Seat Width—Insert-Type Seat Shown

Make two chalk marks on the crankshaft damper 120° away from the timing mark (120° represents 1/3-turn of the crankshaft or 1/3 of the way around the damper circumference).

Turn the crankshaft 1/3-turn in the direction of rotation, and check the valve lash of No. 5 cylinder. Repeat this operation for No. 3, No. 6, No. 2, and No. 4 cylinders.

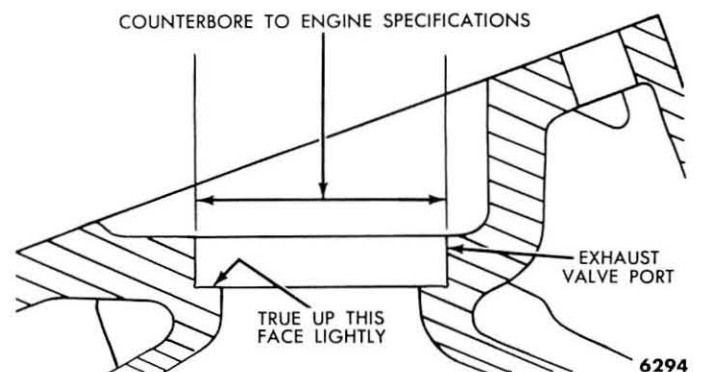

Fig. 25—Counterbore for Oversize Insert

100% SATISFACTION GUARANTEED

BUY IT NOW!

Click Here To Order

Seat

Combination Adjusting Tool

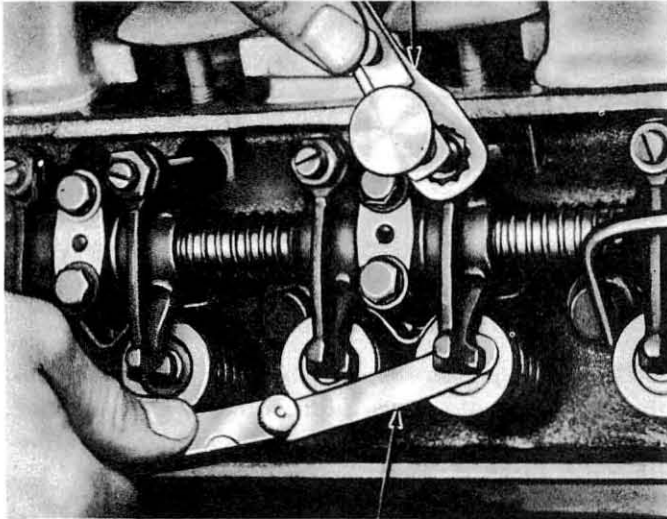

Feeler Gauge

6210

Fig. 26—Valve Lash Check

(b) **FINAL ADJUSTMENT.** Run the engine for approximately 30 minutes at 1200 r.p.m. Check the valve lash for conformance to specifications (fig. 27) with the engine idling. Adjust the lash, if necessary. Install the valve rocker arm cover using a new gasket, if necessary. Do not tighten the cover nuts to more than 2.0-2.5 foot-pounds torque, or the cover will be distorted.

(2) 8-CYLINDER ENGINES.

(a) **PRELIMINARY ADJUSTMENT.** Remove the valve rocker arm covers. Rotate the crankshaft until No. 1 piston is near Top Dead Center (T.D.C.) at the end of the compression stroke.

NOTE: No. 1 piston is near T.D.C. at the end of the compression stroke when both valves are closed and the timing mark on the crankshaft pulley is in line with the pointer.

Check the intake valve lash for conformance to specifications.



ADJUSTING SCREW

Valve gapper

6273

NOTE: To eliminate the possibility of interference with the exhaust manifolds while adjusting the valve lash, bend the proper gauge feeler stock to a 60° angle about one inch from the end.

Loosen the lock nut, and adjust the screw to specifications. Tighten the lock nut without moving the screw. Tighten the nut to 30-35 foot-pounds torque. Check and adjust the exhaust valve lash to specifications in the same manner.

Repeat the procedure for each set of valves, turning the crankshaft ¼-turn while checking the valves in the firing order (1-5-4-8-6-3-7-2).

(b) **FINAL ADJUSTMENT.** Run the engine for approximately 30 minutes at 1200 r.p.m. Check the valve lash with the engine idling, as shown in fig. 26 or 27. Adjust the lash, if necessary.

Install the valve rocker arm cover using a new gasket, if necessary. Tighten the cover nuts to 2.0-2.5 foot-pounds torque. Do not exceed the torque limit or the cover will be distorted.

e. Valve Timing.

Valve timing checks should be made when poor engine performance is noted, and all other checks, such as carburetion, ignition timing, etc. fail to correct the trouble.

The following procedure for checking valve timing is taken on the opening side of No. 1 intake cam lobe. At this point a 1 degree change of the crankshaft is approximately equal to .001-inch change in cam lift.

Remove the valve rocker arm cover on the 6-cylinder engine. On 8-cylinder engines, remove the right valve rocker arm cover.

Turn the engine over until No. 1 intake tappet is on the heel of No. 1 intake cam lobe. (If the No. 1 valve is operating rotate the crankshaft one turn).

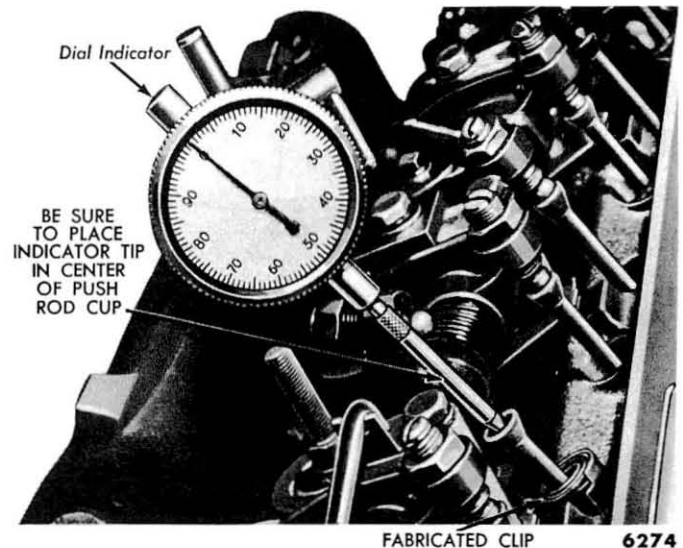

Dial Indicator

BE SURE
TO PLACE
INDICATOR TIP
IN CENTER
OF PUSH
ROD CUP

FABRICATED CLIP

6274

Fig. 28—Camshaft Lobe Lift Check

SATISFACTORY 100% GUARANTEED

BUY IT NOW!

Click Here To Order

PayPal | American Express | Discover | MasterCard | VISA

Back off on the No. 1 valve adjusting screw and push the rocker arm to one side, then install a dial indicator as shown in fig. 28. Zero the dial indicator, then rotate the engine slowly until the desired lift is obtained, as tabulated in Table 2. Compare the degrees on the pulley to the specifications.

If the valve timing is not within specifications, make sure the timing pointer has not been bent. This is done by bringing No. 1 piston to T.D.C. and noticing if the timing pointer is in alignment with the T.D.C. mark on the crankshaft pulley. If the pointer is not at fault, it will be necessary to check the following items in the order of accessibility: timing chain; camshaft sprocket; crankshaft sprocket; camshaft; crankshaft pulley; and crankshaft.

Table 2—Valve Timing Specifications

Engine	Camshaft	Intake Tappet Lift (Opens) At Crankshaft Degrees (B.T.D.C.)
223	EBP-6250-C	13° BTDC With .013 Cam Lift
239	ECE-6250-A	8° BTDC With .015 Cam Lift
256	ECE-6250-A	8° BTDC With .015 Cam Lift
279	EAM-6250-D	18° BTDC With .010 Cam Lift
317	EAM-6250-D	18° BTDC With .010 Cam Lift

6. CAMSHAFT SPROCKET, CAMSHAFT, AND CAMSHAFT BEARINGS

Procedures for the inspection and repair of these components are contained in the following paragraphs.

a. Camshaft Sprocket and Timing Chain.

Before the timing chain is removed, measure the outward deflection from a straight line of the slack side of the chain (fig. 29). If the outward deflection exceeds 1/2-inch, replace the timing chain.

(1) **INSPECTION.** Remove the camshaft sprocket and timing chain. Inspect the sprocket for broken, chipped, or worn teeth. Check the timing chain for loose or worn link pins.

(2) **REPAIRS.** Replace a sprocket that has broken, chipped, or worn teeth. Replace a timing chain that has loose or worn link pins.

b. Camshaft and Camshaft Bearings.

The camshaft must be replaced when the lobes are worn to such an extent that the cam lobe lift (intake and exhaust) is less than the minimum allowable tolerance. Check cam lift with a dial indicator as shown in fig. 28. It will be necessary to fabricate a clip to hold the push rod. The clip shown in fig. 28 is made from banding iron.

(1) **INSPECTION.** Before the camshaft is removed, check the end play for conformance to specifications using a dial indicator in the following manner:

Push the camshaft toward the rear of the engine. Place a dial indicator against the front side of the camshaft flange. Set the dial to zero, then pull the camshaft forward. Compare the dial indicator reading with specifications.

Remove the camshaft. Thoroughly check the camshaft sprocket with a magnifying glass. Examine the sprocket for abnormal wear. Suspected worn sprocket is a good lobe to be sure journal for wear and

out-of-roundness. Measure the camshaft front bearing to journal clearance for conformance to specifications. Check the distributor drive gear for broken or worn teeth. Check the fuel pump eccentric for wear.

(2) **REPAIRS.** Replace all camshafts that have cracks or severely scuffed or scored lobes. Remove light scuffs or scores with a hard Arkansas stone, then polish the lobes with crocus cloth. Remove raised metal from small nicks and abrasions elsewhere on the camshaft in the same manner.

If the front journal to bearing clearance is excessive, it can be assumed that all bearings are worn and need replacement.

If any of the teeth on the distributor drive gear are broken or worn, it will be necessary to replace the camshaft.

If the end play is excessive, replace the thrust plate and/or spacer.

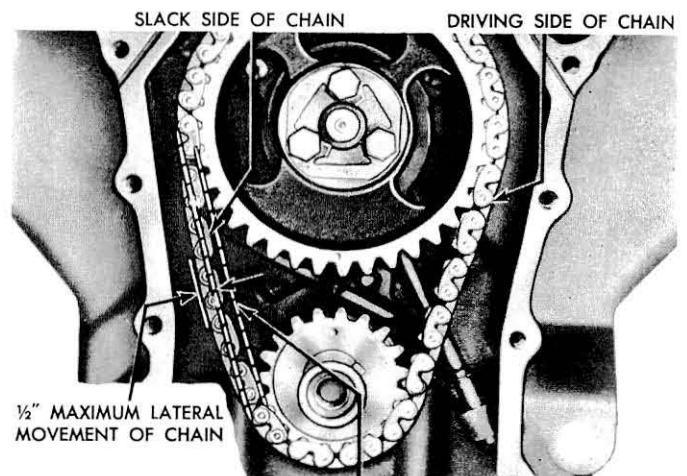

FIRST TAKE UP SLACK OF THIS SIDE OF CHAIN TO ESTABLISH STRAIGHT POSITION OF CHAIN SHOWN IN DOTTED OUTLINE. THEN, TAKE UP SLACK ON DRIVING SIDE OF CHAIN AND MEASURE SLACK SIDE. 1781

Fig. 29—Timing Chain Deflection Check

100% SATISFACTION GUARANTEED

BUY IT NOW!

Click Here To Order

PayPal American Express Discover MasterCard VISA

7. FLYWHEEL, CRANKSHAFT, MAIN BEARINGS, AND CONNECTING ROD BEARINGS

Procedures for the inspection and repair of these components are contained in the following paragraphs.

a. Flywheel.

The flywheel and ring gear are a shrink fit and are replaceable as separate parts.

(1) **INSPECTION.** Check the flywheel face runout with a dial indicator (fig. 30). If the runout exceeds 0.005-inch, remove the flywheel, and check the runout of the crankshaft mounting flange. It will be necessary to remove the crankshaft if the flange requires machining.

Inspect the ring gear for worn, chipped, or cracked teeth. Check the ring gear runout as indicated in fig. 31.

(2) **REPAIRS.** If the flywheel runout exceeds 0.005-inch and the flange is not at fault, the flywheel should be replaced or machined. Machine the friction surface of the flywheel if it is scored. If it is necessary to remove more than 0.045-inch of stock from the original thickness, the flywheel should be replaced.

If the ring gear teeth are chipped, broken, cracked, or worn, or if the runout exceeds 0.010-inch, replace the ring gear as follows:

Heat the defective ring gear with a blow torch on the engine side of the gear, then knock it off the flywheel.

CAUTION: *Do not hit the flywheel when removing the ring gear.*

Heat the new ring gear evenly until the gear expands enough to slip onto the flywheel, then position the gear on the flywheel. Make sure the gear is seated properly against the shoulder.

CAUTION: *Do not heat any portion of the gear to a temperature higher than 500°F. If this limit is exceeded, the temper will be removed from the ring gear teeth. When the new ring gear is installed perform a runout check on the ring gear and flywheel.*

b. Crankshaft.

(1) **CLEANING AND INSPECTION.** Before the crankshaft is removed, check the end play for conformance to specifications using indicator in the following manner:

Push the crankshaft toward the rear of the engine. Place a dial indicator against the rear side of the crankshaft flange. Set the dial on zero then push the crankshaft forward. Compare the reading on the dial indicator with specifications.

After removing the crankshaft, wash it in a solvent, and blow out the oil passages with compressed air. Examine the shaft with a magnifying glass for cracks or other signs of failure.

Measure each crankpin and journal diameter for conformance to specifications. Check the shaft for proper taper and out-of-roundness at several places around the circumference.



6085

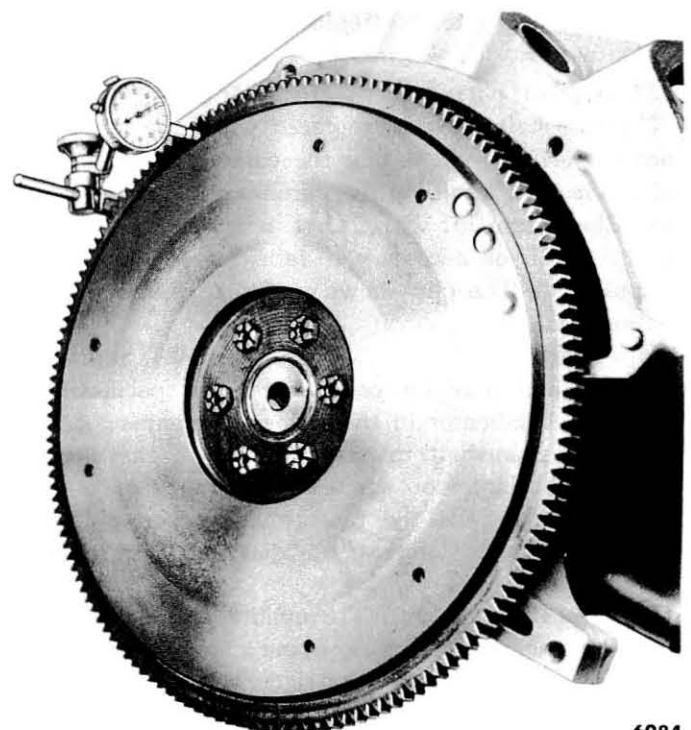

6084

Fig. 31—Ring Gear Runout Check

100% SATISFACTION GUARANTEED

BUY IT NOW!

Click Here To Order

ck

PayPal American Express Cards Discover Network MasterCard VISA

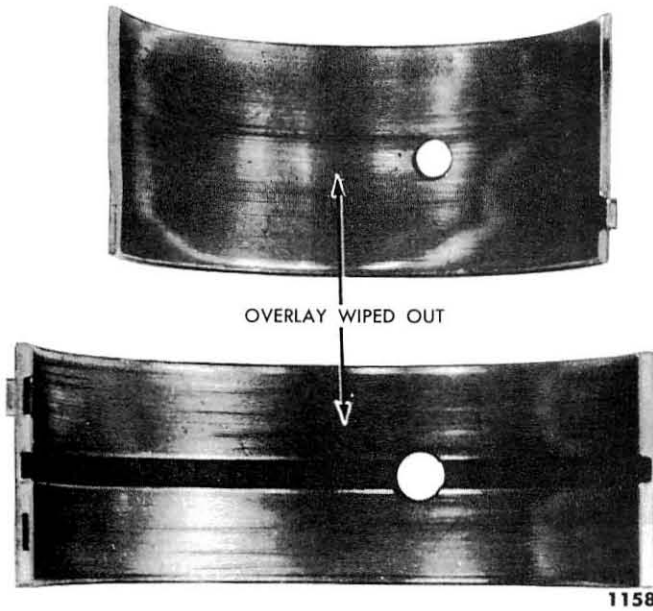

Fig. 32—Bearing Failure—Lack of Oil

(2) **REPAIRS.** If the end play is not within specifications, replace the number three main bearing.

Replace the crankshaft if it shows signs of failure. Dress minor nicks or scratches.

If the pins or journals are out-of-round beyond the specified limits, the shaft should be ground for the next undersize bearing. Calculate the correct undersize bearing to be used as follows:

EXAMPLE: If the main bearing journal will “clean-up” before it is ground to $2.499-0.010 = 2.489$

inches diameter, finish it to that diameter, and install 0.010 undersize bearings.

CAUTION: Never grind journals or crankpins in excess of 0.030-inch undersize.

Always reproduce the same radii in the corners of the pin or journal that existed originally. Too small a radius may result in crankshaft failure, while too large a radius will result in bearing failure.

After grinding, chamfer the oil holes, then polish the pin or journal with No. 320 grit polishing cloth and engine oil. Crocus cloth may also be used as a polishing agent.

c. Main and Connecting Rod Bearings.

Steel-backed, copper-lead bearing inserts are used for both main and connecting rod bearings. Check the bearings for scratches, improper seating, evidence of radius ride, and worn overlay. Examples of bearing failures are illustrated in figs. 32-37. Replace all defective bearings.

(1) **FITTING MAIN AND CONNECTING ROD BEARINGS—PLASTIGAGE METHOD.** The following procedure applies to fitting main bearings with the engine either installed on a workstand or in the vehicle.

If the bearing fits are to be checked with the engine in the vehicle, it will be necessary to support the weight of the crankshaft. Support the weight of the crankshaft with a small jack positioned to hold the crankshaft upward against the block half of the main bearing inserts. The jack should be placed to bear against the crank-

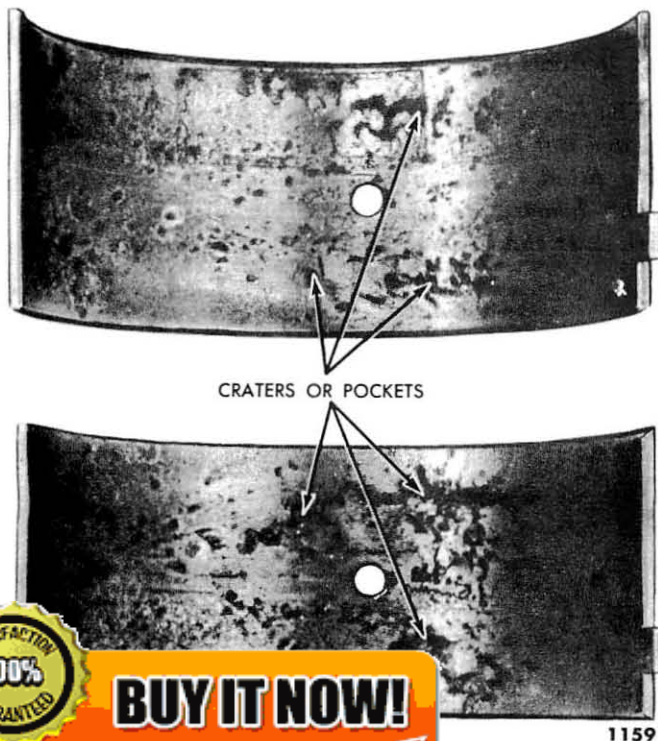

CRATERS OR POCKETS

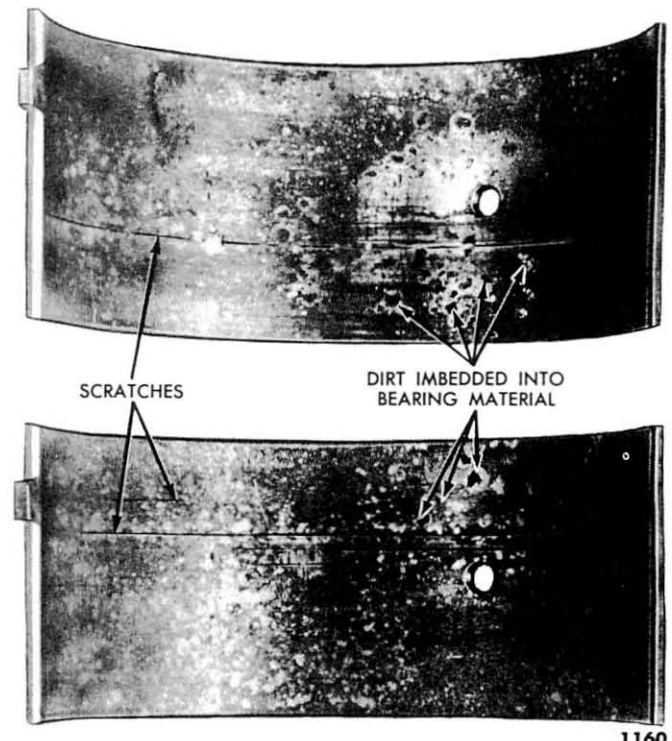

SCRATCHES

DIRT IMBEDDED INTO BEARING MATERIAL

100% SATISFACTORY GUARANTEED

BUY IT NOW!

Click Here To Order

PayPal, American Express, Discover, MasterCard, VISA

1159

1160

Bearing

Fig. 34—Bearing Scratched by Dirt

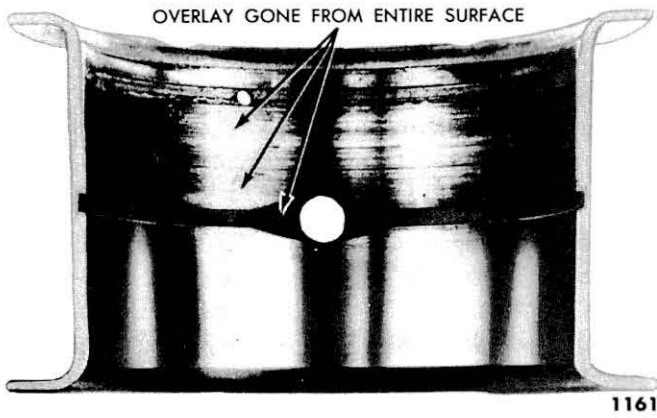
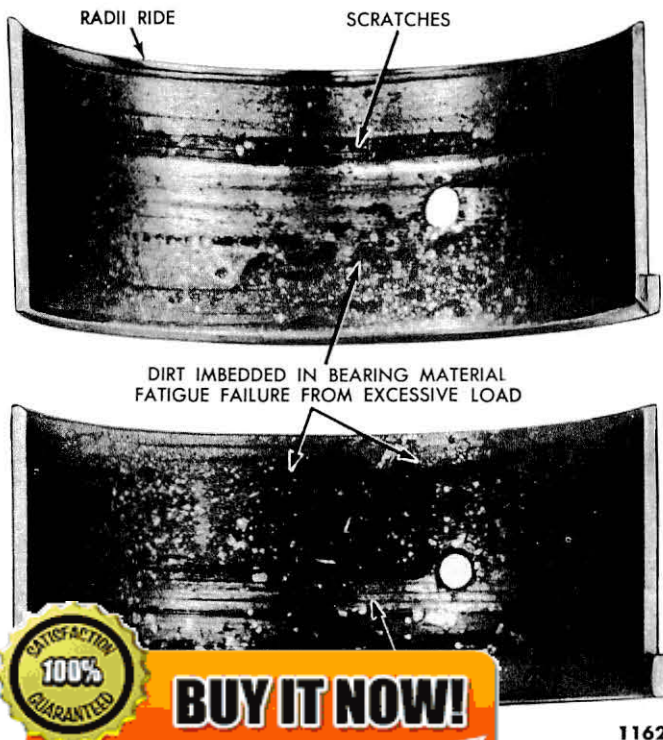

Fig. 35—Bearing Failure—Tapered Journal

shaft counterweight adjoining the bearing which is being checked for clearance. The shaft can also be supported by a thin rubber pad between the cap insert and the journal of two bearings that are not being checked. Tighten these bearing cap bolts just enough to hold the crankshaft up against the upper bearing inserts.

NOTE: *It is necessary to support the weight of the crankshaft when checking main bearing clearances, in order to prevent the weight of the crankshaft from compressing the Plastigage, thereby providing an erroneous reading.*

Place a piece of Plastigage, the full width of the bearing cap insert, on the bearing surface (or on the crankshaft journal if the engine is inverted) about



Ride

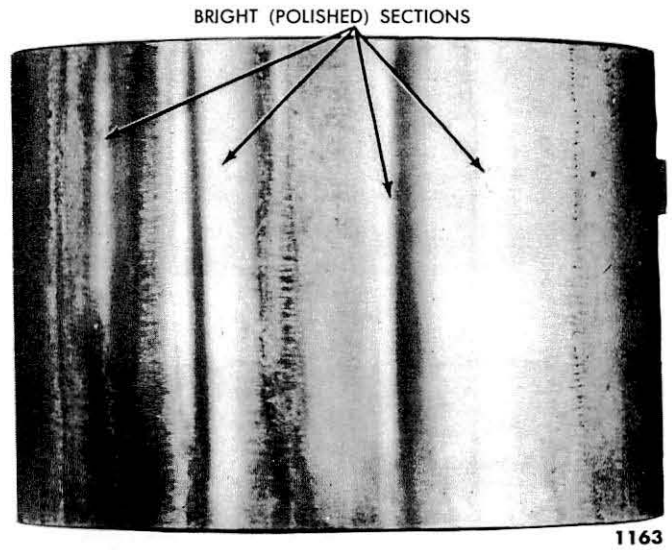

Fig. 37—Bearing Bright Spots—Improper Seating

1/4-inch off center. Install the cap and tighten the bolts to specifications.

CAUTION: *Do not turn the crankshaft while the Plastigage is in place.*

Remove the cap, and check the width of the Plastigage, at the widest point, with the Plastigage scale (fig. 38).

If the clearance is not within limits, try another selective fit bearing to bring the clearance within the desired limit. Red marked bearings increase clearance, blue marked bearings decrease clearance. If the various selective fit bearings do not bring the clearance within specifications, it will be necessary to regrind the crankshaft journals and install undersize bearing inserts.

NOTE: *Normally, main bearing journals wear evenly and are not out-of-round. However, if a bearing is being fitted to an out-of-round journal, be sure to fit the bearing to the maximum diameter of the journal. If the bearing is fitted to the minimum dia-*

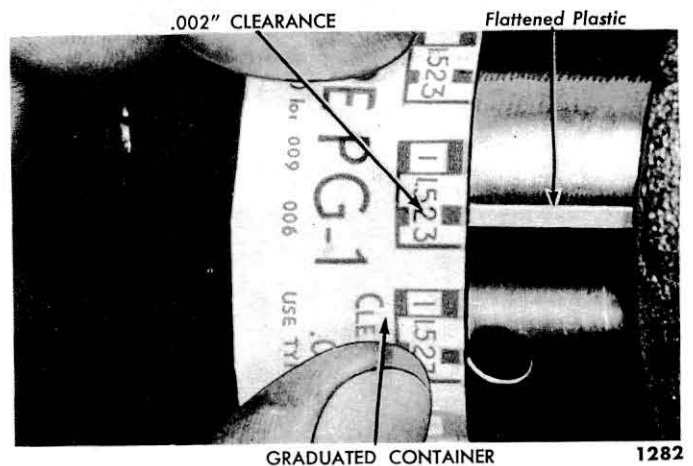

Fig. 38—Measuring Plastigage

100% SATISFACTION GUARANTEED

BUY IT NOW!

Click Here To Order

meter with minimum clearance, interference may result, causing an early failure. It is not recommended that bearings be fitted to a crankshaft journal which is more than 0.001-inch out-of-round.

(2) **THRUST BEARING ALIGNMENT.** Install the main bearing caps, except the thrust bearing cap, and tighten the cap bolts to specifications. Install the thrust bearing cap with the bolts finger-tight, then pry the crankshaft forward to properly position the thrust surface of the upper half of the bearing. While holding the crankshaft forward, pry the thrust bearing cap to the rear. This will align the thrust surfaces of both halves of the bearing. Retain the forward pressure on the crankshaft, and tighten the cap bolts to specifications. Check the crankshaft end play.

(3) **REPLACING REAR MAIN BEARING OIL SEALS.** Remove the rear main bearing and journal oil seal from the cylinder block. Remove the old sealing material, and clean the seal groove in the cylinder block. Repeat this procedure for the oil seal retaining cap. Remove the oil seal retaining cap to block seals.

Install a new journal oil seal in the cylinder block as shown in fig. 39. The cylinder block journal seal and the retaining cap journal seal must be cut flush without any frayed edges overlapping. Install a new journal seal in the oil seal retaining cap as shown in fig. 40. Install new retaining cap to cylinder block seals with an 0.080-inch overlap. Lubricate the seals with grease to reduce friction.

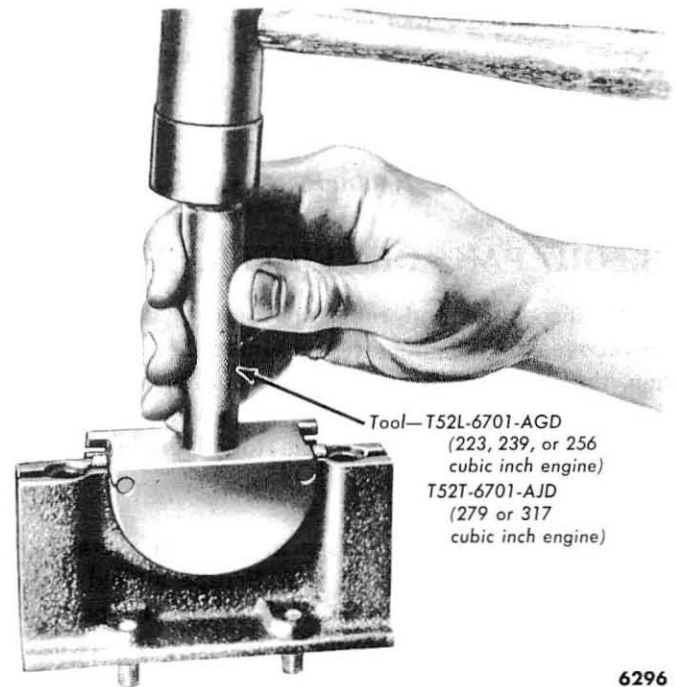

6296

Fig. 40—Rear Journal Oil Seal to Seal Retainer Installation—Typical

NOTE: On 239 and 256 cubic inch engines, dip the retainer to cylinder block seals in light engine oil, then immediately install them in the retainer. It may be necessary to tap the seals into place the last 1/2-inch of travel.

Install the crankshaft and main bearing caps and inserts. Install the oil seal retaining cap guide studs into the cap bolt holes in the block. On 279 and 317 cubic inch engines, install the oil seal retainer and seal

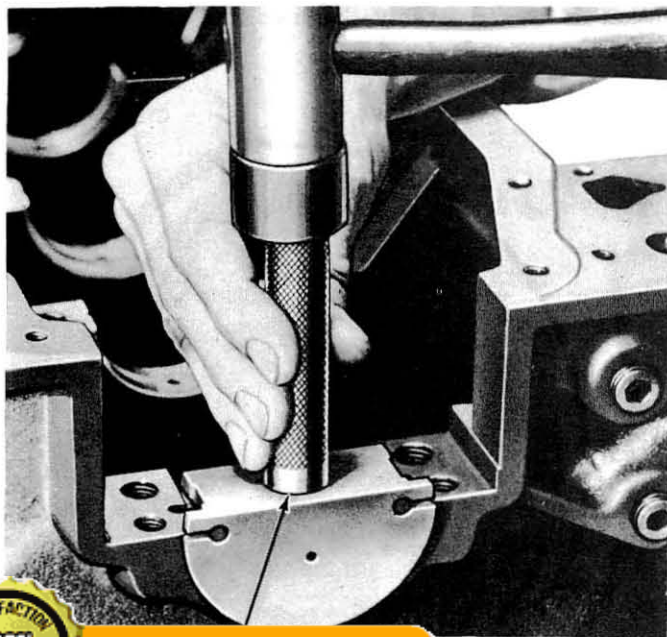

6295

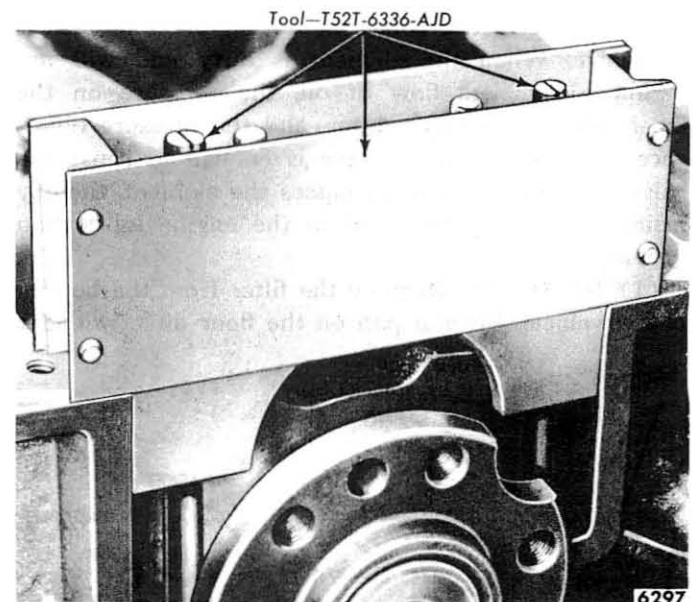

6297

Fig. 41—Oil Seal Retaining Cap Installation—279 or 317 Cubic Inch Engine

100% SATISFACTION GUARANTEED

BUY IT NOW!

Click Here To Order

PayPal American Express Discover MasterCard VISA

assembly with the tool shown in fig. 41. This tool is not required on the 239 or 256 cubic inch engine. Install the two screws that retain the cap to the cylinder block.

NOTE: Check the retainer to cylinder block seal

8. OIL PAN, OIL FILTER, AND OIL PUMP AND PRESSURE RELIEF VALVE

The inspection and repair procedures applicable to the above components are presented below. In addition, the removal, disassembly, assembly, and installation procedures for the oil filter are given, inasmuch as these procedures are applicable to all engines.

a. Oil Pan.

Remove the oil pan. Scrape any dirt or metal particles from the inside of the pan. Scrape all old gasket material from the gasket surface. Wash the pan in a solvent and dry it thoroughly.

Check the pan for cracks, holes, damaged drain plug threads, a loose baffle, or warped gasket surface.

Repair any damage, or replace the pan if repairs cannot be made.

b. Oil Filter.

The full flow-type oil filter, used on all engines, filters the entire output of the pump before the oil enters the engine lubrication system.

A built in by-pass provides oil to the system in case the filter element becomes clogged. The by-pass is located in the hollow center bolt and consists of a spring loaded valve. When the element is clean and oil will flow through it, the pressure difference between the inner and outer faces of the valve is not great enough to overcome the spring pressure behind the valve. When the element is dirty and will not permit a sufficient flow of oil, the pressure on the inner face of the valve drops, and the pressure difference between the valve faces is enough to cause the valve to open. Oil then by-passes the element, thereby maintaining a supply of oil to the engine lubrication system.

(1) **REMOVAL.** Remove the filter from the bottom of the vehicle. Place a pan on the floor directly under

for leaks. Squirt a few drops of oil into the corners of the seals on the inside of the cylinder block. Blow compressed air into the seal corners from the inside of the block. If oil seeps past the seal, remove the seal retainer. Be sure all mating surfaces are clean. Install new seals and repeat the air test.

the filter. Remove the filter center bolt, then remove the filter assembly and gasket.

(2) **DISASSEMBLY.** Remove the filter element, neoprene gasket, spring, and seat, then remove the center bolt and fibre gasket from the cover. Discard the filter element and all gaskets. The oil filter is shown disassembled in fig. 42.

(3) **CLEANING.** Wash all parts in a solvent and dry them thoroughly. Make sure all the openings in the center bolt are clean.

(4) **ASSEMBLY.** Install a new fibre gasket on the center bolt, then place the bolt through the filter housing. Install the spring and spring seat assembly on the bolt, making sure the seat tangs are engaged in the spring. Install a new neoprene gasket and a new filter element over the center bolt.

(5) **INSTALLATION.** Be sure the two elongated holes in the oil filter diaphragm are at the top, when positioned on the block, as shown in fig. 43. Install a new neoprene gasket in the filter housing recess. Place the filter assembly in position, and thread the center bolt into the adapter, finger-tight. Rotate the filter assembly slightly, in each direction, to make sure the gasket is seated evenly. Tighten the center bolt to 20-25 foot-pounds torque.

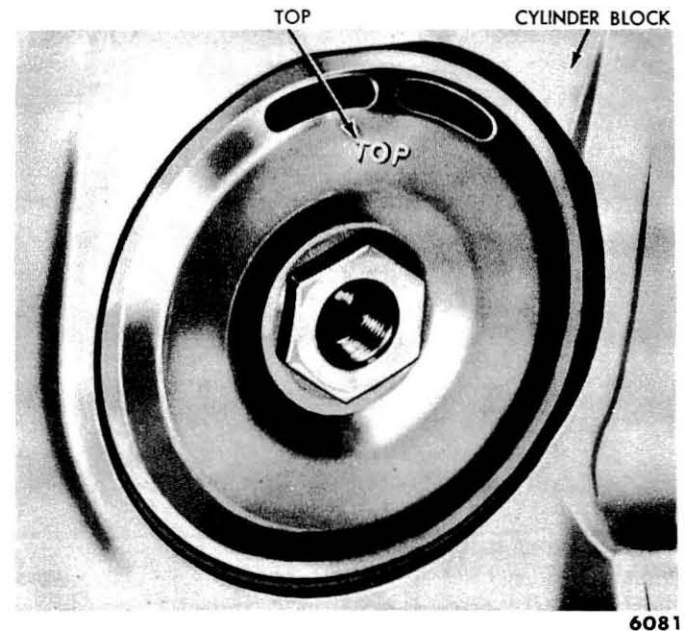

Fig. 43—Oil Filter Diaphragm Position

With the engine at normal operating temperature and operating at fast idle, check for oil leaks past the housing gasket or around the center bolt gasket. If oil leaks past the housing gasket, check the housing for proper seating. If oil leaks past the center bolt gasket, check the center bolt for proper torque.

c. Oil Pump and Pressure Relief Valve

Remove and disassemble the oil pump and pressure relief valve. Wash all parts in a solvent and dry them

thoroughly. Use a brush to clean the inside of the pump housing and the pressure relief valve bore. Be sure all dirt and chips are removed. Remove all old gasket material from the pump body and cover.

Check the pump housing for damage or excessive wear. Check the pump gear teeth for damage or wear. Check the compression of the relief valve spring. Check the relief valve clearance in the relief valve bore. Check the driven shaft clearance.

Replace any worn or defective parts.

9. CYLINDER BLOCK, PISTONS, PISTON RINGS, AND CONNECTING RODS

Procedures for checking the cylinder block; for cleaning, inspecting, and fitting pistons; for fitting piston rings; and for checking connecting rod alignment are given below.

a. Cylinder Block.

Make a thorough check for cracks. Minute cracks not visible to the naked eye may be detected by coating the suspected area with a mixture of 25% kerosene and 75% light motor oil. Wipe the part dry and immediately apply a coating of zinc oxide dissolved in wood alcohol. If cracks are present, the coating will become discolored at the defective area.

Inspect the cylinder bores for scores. Check the cylinder bore for taper, out of round, and wear. Use a cylinder bore gauge, telescope gauge, or inside micrometers. Measuring the cylinder with a cylinder bore gauge is illustrated in fig. 44. Only experienced personnel should be permitted to take these measurements.

Rebore the cylinder when the taper and/or out-of-roundness exceed the maximum allowable tolerances.

b. Pistons, Piston Pins, and Rings.

Before removing a piston from the engine, remove any ridges that may be present along the upper part of each cylinder as follows:

Move the piston to the bottom of its travel, and place a cloth on the piston head to collect the cuttings. Remove the cylinder ridge as shown in fig. 45, according to the instructions furnished by the manufacturer of the ridge cutter being used.

CAUTION: *Never cut into the ring travel area in excess of 1/32 inch when removing ridges.*

Remove the ridge cutter from the cylinder bore. Turn the crankshaft until the piston is at the top of its stroke and carefully remove the cloth with the cuttings from the piston head. Remove the pistons.

CLEANING AND INSPECTION. Clean the cylinder bore with a wire brush and solvent. Use a caustic cleaning solution (fig. 46). Clean the piston rings and use a caustic cleaning solution (or holes)

Inspect pistons for fractures at the ring lands, skirt, and pin bosses. Spongy, eroded areas near the edge of the piston top, usually on the side opposite the valves, are caused by detonation, or pre-ignition.

Inspect the piston pins for signs of fracture or etching. Check the pin for proper fit in the piston and rod bushing.

(2) **REPAIRS.** Replace pistons showing signs of excessive skirt clearance, wavy ring lands, fractures or damage from detonation.

Replace piston pins showing signs of fracture or etching. Piston pins that show wear or fit loosely in the piston or rod bushing should be replaced. Replace all piston pin retainers.

(3) **FITTING PISTONS.** To fit a piston in the cylinder bore, attach a tension scale to the end of a feeler gauge ribbon which is 1/2-inch wide and which has the proper thickness. Position the feeler on the side of the piston 90° from the piston pin hole. Invert the piston, then push the piston and feeler into the bore so the end of the piston is approximately 5/8-inch below the top of the block. Keep the piston pin bore parallel to the crankshaft axis. Hold the piston and pull out the feeler ribbon, noting the reading on the pull scale (fig. 47).

If the scale reading is greater than the maximum

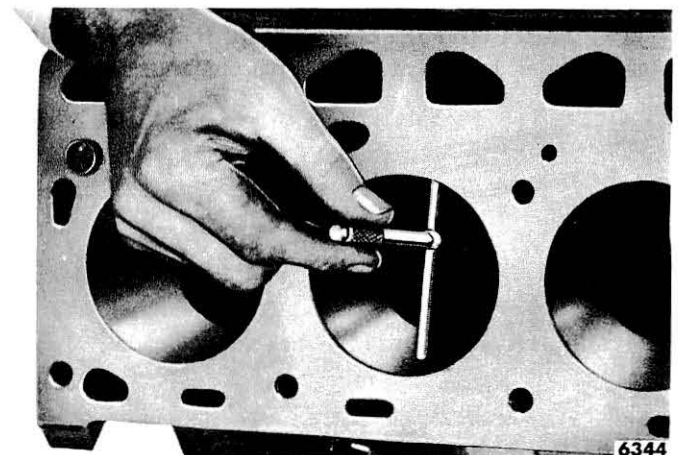

Fig. 44—Measuring Cylinder Bore

100% SATISFACTION GUARANTEED

BUY IT NOW!

Click Here To Order

PayPal American Express Discover MasterCard VISA

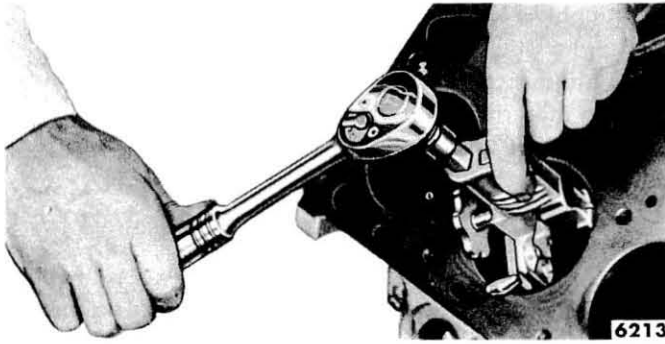

Fig. 45—Cylinder Ridge Removal

allowable pull, check for a damaged piston, try a new piston, or hone the cylinder bore to obtain the proper fit.

If the scale reading is less than the minimum allowable pull, try another piston. If none can be fitted, rebore the cylinder to the next oversize piston.

NOTE: All pistons are the same weight, both standard and oversize; therefore pistons of various sizes can be intermixed without upsetting engine balance. Rebore only the cylinder or cylinders which require it.

(4) **FITTING PISTON PINS.** The piston pin should have 0.0001-0.0003 inch clearance in both the connecting rod and the piston.

If the piston pin hole must be reamed, use an expansion-type piloted reamer. Place the reamer in a vise and revolve the piston around the reamer. Set the reamer to the size of the pin bore, then expand the reamer slightly and trial ream the pin bore, using a pilot sleeve of the nearest size to maintain alignment of the bores.

CAUTION: Take a very light cut.

Check the reamed hole size, using the piston pin for the piston being reamed. If the bore is small, expand the reamer slightly and make another trial cut. Repeat the procedure until the proper fit is obtained.

(5) **FITTING PISTON RINGS.** Install the ring in the cylinder bore. Invert the piston, and use the top

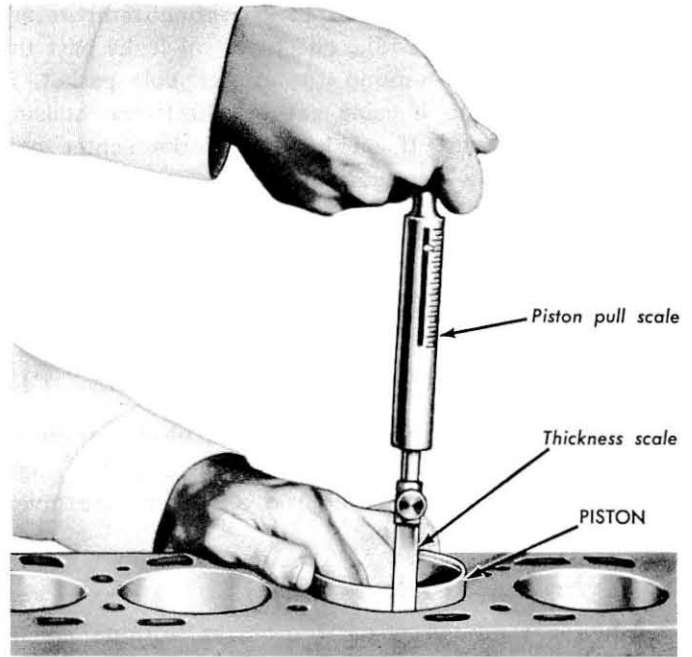

Fig. 47—Piston Fit Check—Typical

to push the ring about halfway down the bore to square the ring. Measure the ring gap with a feeler gauge.

Be sure to identify the rings with the piston and bore in which they are to be used.

Check the ring to groove side clearance with the ring installed on the proper piston (fig. 48).

Whenever piston rings are installed in a used cylinder, the "glaze" on the bore should be removed to aid in ring seating.

c. Connecting Rods.

(1) **CLEANING AND INSPECTION.** Clean all parts and passages in solvent. Never use a caustic cleaning solution. Remove the bearing inserts (identify them



100% SATISFACTION GUARANTEED

BUY IT NOW!

Click Here To Order

PayPal | American Express | Discover | MasterCard | VISA

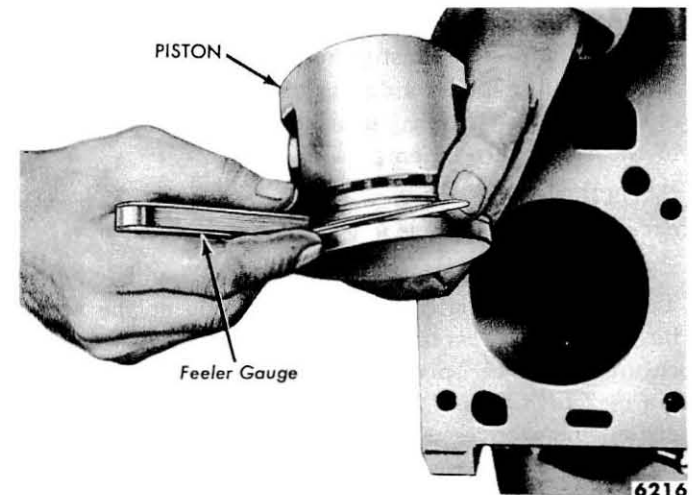

Fig. 48—Ring Clearance Check