



FORD

PASSENGER CAR

SHOP MANUAL



1952, 1953 and 1954

FORD DIVISION
FORD MOTOR COMPANY

100% SATISFACTION GUARANTEED

BUY IT NOW!

Click Here To Order 

PayPal    



Copyright © 2012, Forel Publishing Company, LLC, Woodbridge, Virginia

All Rights Reserved. No part of this book may be used or reproduced in any manner whatsoever without written permission of Forel Publishing Company, LLC. For information write to Forel Publishing Company, LLC, 3999 Peregrine Ridge Ct., Woodbridge, VA 22192

1952, 1953 and 1954 Ford Passenger Car Shop Manual

EAN: 978-1-60371-061-9

ISBN: 1-60371-061-2

Forel Publishing Company, LLC

3999 Peregrine Ridge Ct.

Woodbridge, VA 22192

Email address: sales@ForelPublishing.com

Website: <http://www.ForelPublishing.com>



This publication contains material that is reproduced and distributed under a license from Ford Motor Company. No further reproduction or distribution of the Ford Motor Company material is allowed without the express written permission of Ford Motor Company.

Note from the Publisher

This product was created from the original Ford Motor Company's publication. Every effort has been made to use the original scanned images, however, due to the condition of the material; some pages have been modified to remove imperfections.

Disclaimer

Although every effort was made to ensure the accuracy of this book, no representations or warranties of any kind are made concerning the accuracy, completeness or suitability of the information, either expressed or implied. As a result, the information contained within this book should be used as general information only. The author and Forel Publishing Company, LLC shall have neither liability nor responsibility to any person or entity with respect to any loss or damage caused, or alleged to be caused, directly or indirectly by the information contained in this book. Further, the publisher and author are not engaged in rendering legal or other professional services. If legal, mechanical, electrical, or other expert assistance is required, the assistance of a professional should be sought.





1952

FORD
PASSENGER CAR

SHOP MANUAL

Copyright 1952
FORD MOTOR COMPANY
DEARBORN, MICHIGAN
All rights reserved

FORD DIVISION
FORD MOTOR COMPANY

100% SATISFACTION GUARANTEED

BUY IT NOW!

Click Here To Order 

April, 1952

PREFACE

This manual combines under one cover complete service information for the 1952 Ford Passenger Car. All aspects of the servicing of the parts, assemblies, or systems involved will be found here. Repair men will find step by step procedures plus disassembled views of all of the assemblies. The diagnostician will find that working procedures for each kind of trouble he will encounter are covered. Maintenance and lubrication data is provided for those interested in this aspect of service. Service Managers and salesmen will find hints of everyday care that they can pass on to their customers. Collision men will find construction detail well illustrated to assist them in collision work. Electrical men will find simply written principles, not only of operation, but of testing as well for each of the electrical units or systems. Upholstery men will find how-to-do-it procedures for their work.

Step-by-step procedures for the disassembly, inspection, and repair are presented throughout this manual. In addition, each assembly has been illustrated disassembled, with each of the component parts arranged in the order of assembly or disassembly. In many cases, a glance at these illustrations will tell you all you need to know about how the parts go together. These illustrations carry basic part numbers for each of the parts. These basic numbers plus the model number of the car will permit you to order parts from any Ford dealer even though you may not have a "Parts Book."

In recognition of the specialization that is currently practiced in many service establishments, this manual has been divided into five major divisions. These five parts are as follows:

Part ONE—POWER PLANT—has to do with the Ford engines and the various systems that are necessary to their operation. These include fuel system, ignition system, and the cooling system.

Part TWO—CHASSIS—starting with the clutch, covers the entire power train (clutch, standard transmission, Overdrive, Fordomatic transmission, drive line, rear axles, etc.) and the running gear (wheels, tires, brakes, springs, suspension, frames, steering gear, and linkages, etc.).

missions which are covered in **Part TWO**, for Ford cars.

Part FOUR—BODIES—contains complete information on the maintenance and repair of all body components, including adjustment and alignment not only of the body proper, but also of doors, deck lids, hoods, and fenders. In addition, convertible top maintenance and glass adjustments are given.

Part FIVE—MAINTENANCE, TROUBLE SHOOTING, AND SPECIFICATIONS—has been arranged in the back of the book separately for the convenience of quick service men. In this part, all of the information ordinarily required for quick service men and service salesmen has been combined into three separate chapters.

The Table of Contents on the next page shows not only the part break-down as described above, but also the chapters that have been established in each of the five parts. Each chapter has been divided into sections which also are listed in the Table of Contents. Regardless of the aspect of service in which you are interested or the unit of the vehicle in which you may be specializing, a glance at the Table of Contents will quickly direct you to the portion of this manual in which you are interested. If you are interested in maintenance procedures, trouble shooting, or specifications, the information you desire will be found in **Part FIVE**. Otherwise, it will fall in one of the four other parts. A quick glance at the chapter and section listings under the part involved will direct you to the page desired.

Throughout this manual the top of each left-hand, even-numbered page gives the name of the chapter; and the top of each right-hand, odd-numbered page gives the name of the section involved. Thus, regardless of where you open the manual, a glance at the top of the two pages will tell you exactly what subject matter is discussed at that point.

No one expects even the most experienced mechanic to remember all details of servicing these cars and you will find that you will have to occasionally refer to this manual. Keep your manual where it will be readily available for reference at all times.

FORD DIVISION
FORD MOTOR COMPANY
SERVICE DEPARTMENT

100% SATISFACTION GUARANTEED

BUY IT NOW!

Click Here To Order

electrical system which is the accessories, automatic trans-

PayPal American Express Discover MasterCard VISA

TABLE OF CONTENTS

Preface.....	Page 2
--------------	-----------

Part ONE—POWER PLANT

CHAPTER I—EAA SERIES—6-CYLINDER ENGINE

		Page			Page
Section 1	Engine Removal and Installation.....	5	Section 6	Crankshaft Damper.....	17
2	Manifolds.....	8	7	Cylinder Front Cover and Oil Seal.....	17
3	Cylinder Head.....	9	8	Camshaft Sprocket, Camshaft, and Bearings.....	18
4	Valves, Valve Mechanism, and Valve Lash Adjustment.....	11	9	Flywheel, Crankshaft, and Bearings.....	20
5	Oil Pan, Filter, Oil Pump and Pressure Relief Valve.....	14	10	Connecting Rods, Pistons, and Rings...	26
			11	Exhaust System.....	31

CHAPTER II—EAB SERIES—8-CYLINDER ENGINE

Section 1	Engine Removal and Installation.....	34	Section 7	Valves, Springs, Guides, and Seats.....	41
2	Manifolds.....	36	8	Camshaft Gear, Camshaft, and Bearings.....	43
3	Cylinder Heads.....	37	9	Flywheel, Crankshaft, and Bearings.....	45
4	Oil Pan, Oil Pump, and Pressure Relief Valve.....	38	10	Connecting Rods, Pistons, and Rings...	50
5	Crankshaft Pulley Replacement.....	40	11	Exhaust System.....	54
6	Cylinder Front Cover.....	41			

CHAPTER III—IGNITION, FUEL, AND COOLING

Section 1	Ignition.....	57	Section 6	8-Cylinder Carburetor Overhaul.....	75
2	Distributor Minor Repair and Adjustment.....	60	7	Fuel Pumps and Vacuum Booster.....	78
3	Distributor Overhaul.....	63	8	Fuel Tanks and Lines.....	82
4	Carburetor Operation and Adjustment..	67	9	Fans and Belts.....	82
5	6-Cylinder Carburetor Overhaul.....	71	10	Water Pumps.....	84
			11	Radiator, Hoses, and Thermostats.....	86

Part TWO—CHASSIS

CHAPTER I—CLUTCH AND TRANSMISSION

Section 1	Clutch.....	89	Section 3	Transmission Overhaul.....	92
2	Transmission Replacement.....	92	4	Gear Shift Linkage.....	97

CHAPTER II—OVERDRIVE

Section 1	Operating Principles.....	99	Section 4	Assembly.....	105
2	Removal.....	102	5	Installation.....	106
3	Disassembly and Inspection.....	103			

CHAPTER III—FORDOMATIC TRANSMISSION

Section 1	Construction and Operation.....	107	Section 4	Transmission Overhaul.....	128
2	Maintenance and Adjustment.....	117	5	Converter Overhaul.....	149
3	Replacement.....	122			

CHAPTER IV—REAR AXLE AND DRIVE LINES

Section 1	Passenger Car Rear Axle.....	151	Section 3	Drive Lines.....	163
2	Station Wagon and Sedan Delivery Rear Axle.....	159			

CHAPTER V—RUNNING GEAR

		165	Section 5	Steering Gear.....	174
		168	6	Steering Linkage.....	178
		172	7	Wheels and Tires.....	182
		173	8	Hubs and Bearings.....	184

100% SATISFACTION GUARANTEED

BUY IT NOW!

Click Here To Order

CHAPTER VI—BRAKES

	Page		Page		
Section 1	Adjustments	188	Section 4	Brake Drums	194
2	Hydraulic System	189	5	Parking Brake	194
3	Brake Assemblies	193			

Part THREE—ELECTRICAL AND ACCESSORIES

CHAPTER I—ELECTRICAL SYSTEMS

Section 1	Generating System and Battery	197	Section 4	Horns	226
2	Starting System	213	5	Instruments	227
3	Lighting System	219			

CHAPTER II—ACCESSORIES

Section 1	Radio	231	Section 3	Windshield Wiper	240
2	Heater	237	4	Miscellaneous Accessories	241

Part FOUR—BODIES

CHAPTER I—BODY CONSTRUCTION AND MAINTENANCE

Section 1	Construction Details and Sealer Application	245	Section 5	Front Fender Alignment	257
2	Door Alignment	251	6	Body Alignment	259
3	Deck Lid Alignment	254	7	Quarter Panel Repair	261
4	Hood Alignment	256	8	General Body Maintenance	263

CHAPTER II—HARDWARE, GLASS, UPHOLSTERY, AND FLAT TRIM

Section 1	Door Locking Mechanism	265	6	Grille and Hood	279
2	Window Regulators	268	7	Deck Lid Locking Mechanism	280
3	Door Ventilator Assembly	270	8	Door and Quarter Trim Panels	281
4	Door and Quarter Glass	271	9	Headlining Replacement	284
5	Windshield and Rear Window	274			

CHAPTER III—CONVERTIBLE COUPE, VICTORIA, AND COUNTRY SQUIRE

Section 1	Convertible Top Power System	287	Section 3	Convertible and Victoria Window Adjustments	291
2	Convertible Top Alignment	289	4	Care of Country Squire Paneling	294

Part FIVE—MAINTENANCE, TROUBLE SHOOTING, AND SPECIFICATIONS

CHAPTER I—MAINTENANCE PROCEDURES

Section 1	Engine Tune-up	299	Section 4	Lubrication	305
2	Wheel Alignment	301	5	Preventive Maintenance	308
3	Brake Adjustment	305			

CHAPTER II—TROUBLE SHOOTING

Section 1	Power Plant	311	Section 5	Accessories	331
2	Suspension, Steering Gear, and Tire Wear	320	6	Power Train	335
3	Brakes	322	7	Overdrive	335
4	Electrical and Instruments	323	8	Fordomatic Transmission	337

CHAPTER III—SPECIFICATIONS

Section 1	Wheels and Tires	340	Section 9	Fuel System	346
2	Brakes	340	10	Generating System	346
	Wheel Alignment and Steering	340	11	Starting System	346
		341	12	Ignition	347
		342	13	Lights and Horns	347
		342	14	Wiring Diagrams	348
		344	15	Tools and Equipment	350
		345			



Part ONE POWER PLANT

Chapter I

EAA Series—6-Cylinder Engine

Section		Page
1	Engine Removal and Installation	5
2	Manifolds	8
3	Cylinder Head	9
4	Valves, Valve Mechanism, and Valve Lash Adjustment	11
5	Oil Pan, Filter, Oil Pump, and Pressure Relief Valve	14
6	Crankshaft Damper	17
7	Cylinder Front Cover and Oil Seal	17
8	Camshaft Sprocket, Camshaft, and Bearings	18
9	Flywheel, Crankshaft, and Bearings	20
10	Connecting Rods, Pistons, and Rings	26
11	Exhaust System	31

The EAA series passenger car engine has 6-cylinders with a displacement of 215 cubic inches. The engine is rated at 101 horsepower with a $3\frac{3}{16}$ inch cylinder bore and a 3.6 inch stroke. The exterior features of the engine are illustrated in figs. 1 and 2.

Complete removal, repair, and installation information is included in this Chapter covering all the component parts of this engine as listed above.

Always use new gaskets when making repair or replacement procedures. A complete engine overhaul gasket kit is available for service.

1. ENGINE REMOVAL AND INSTALLATION

Engine removal and installation procedures include removal and installation without transmission, or removal and installation with transmission.

a. Removal Without Transmission.

If the vehicle is equipped with standard or overdrive transmission, follow "(1) Preliminary Steps—Standard

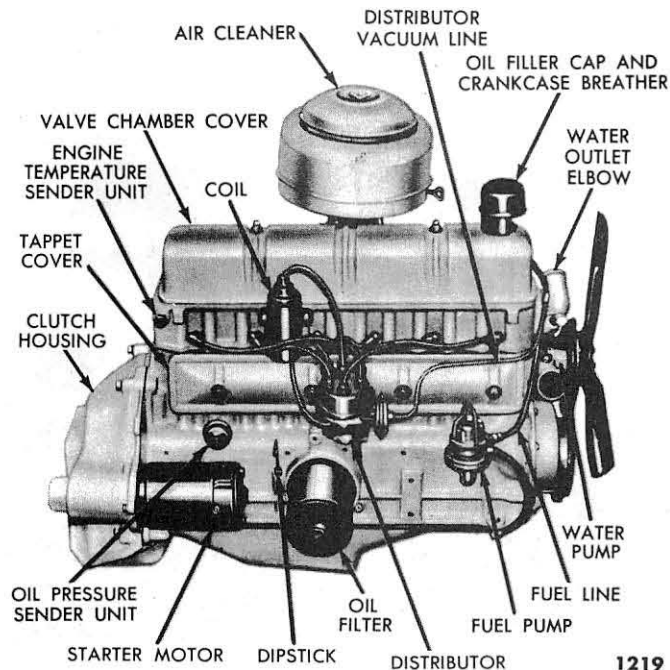
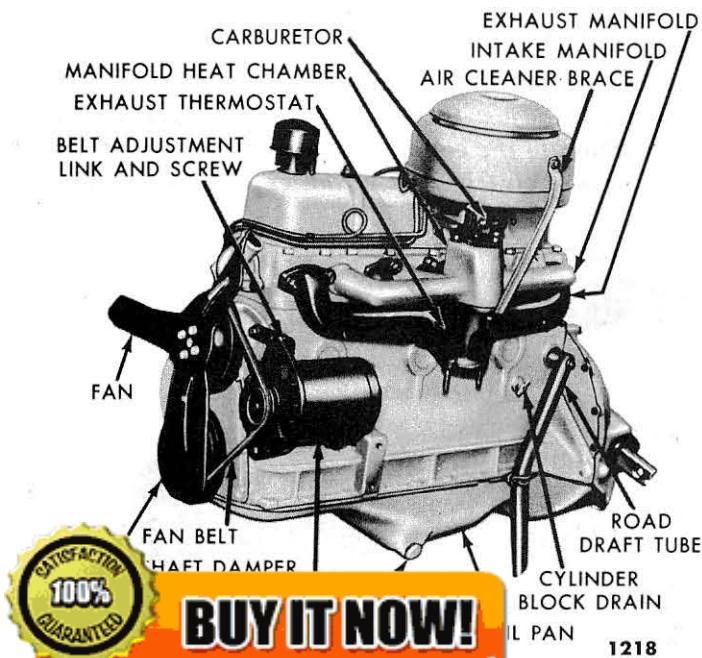

Fig. 2—EAA Series Engine (Right Side View)

100% SATISFACTION GUARANTEED

BUY IT NOW!

Click Here To Order

PayPal, American Express, Discover, MasterCard, VISA

or Overdrive Transmission,” then proceed with “(3) Engine Removal.” If the vehicle is equipped with Fordomatic, follow “(2) Preliminary Steps—Fordomatic,” then proceed with “(3) Engine Removal.”

(1) **PRELIMINARY STEPS—STANDARD OR OVERDRIVE TRANSMISSION.** Disconnect the clutch pedal retracting spring and the clutch release rod. Remove the screws retaining the clutch equalizer bar support to the flywheel housing, remove the support and bushing, and let the equalizer bar and clutch release rod hang from the frame. Remove the transmission to flywheel housing screws. Place a jack under the transmission and raise the jack until it just touches the transmission.

(2) **PRELIMINARY STEPS—FORDOMATIC.** Fold back the front floor mat, remove the two rubber plugs, and remove the two top converter housing to engine bolts. Support the transmission with a jack and remove the remaining converter housing to engine bolts. Remove the engine rear plate to converter housing bolts. Remove the converter housing lower access cover, then remove the six converter to flexplate bolts.

Disconnect the throttle linkage at the cross shaft and tie the linkage to the dash panel. Disconnect the accelerator pedal shaft at the accelerator cross shaft and remove the screws retaining the accelerator cross shaft to the dash panel. Remove the starter motor.

(3) **ENGINE REMOVAL.** Drain the coolant. Remove the hood and radiator. Disconnect the heater hose at the engine. Remove the heater blower motor. Disconnect the generator wires, engine temperature sending unit wire, oil pressure sending unit wire, and the ignition switch to coil wire at the various units on the engine.

Remove the air cleaner and tape the carburetor opening closed. Disconnect the choke wire at the carburetor.

Disconnect the windshield wiper hose at the manifold. Disconnect the accelerator linkage at the manifold bellcrank (except Fordomatic). Disconnect the starter cable at the starter motor (except Fordomatic). Disconnect the muffler inlet pipe at the exhaust manifold and pull the pipe away from the manifold studs. Disconnect the fuel pump flexible line.

Install the engine lift bracket (fig. 3). Use the front notch in the bracket for proper engine balance, and take up the load with a hoist. Remove the engine front support bolts. Lift the engine slightly, adjust the jack supporting the transmission, and gently pull the engine away from the transmission. Raise the engine carefully, pull it forward over the crossmember, and lift it out of the compartment. Do not let the engine swing against the grille.

Install the engine on a work stand using the adapter shown in fig. 4. Remove the lift bracket.

b. Installation Without Transmission.

If the vehicle is equipped with standard or overdrive transmission, follow steps (1) and (2) below. If the vehicle is equipped with Fordomatic, follow steps (1) and (3).

(1) **ENGINE INSTALLATION.** Install the engine lift bracket. Using the front notch for proper engine balance, take up the load with a hoist. Remove the engine from the work stand. Lower the engine carefully into the compartment. Center the clutch release bearing on the clutch and start the transmission main drive gear through the bearing and into the clutch disc (except Fordomatic). On Fordomatic units, start the converter pilot into the crankshaft.

NOTE: On standard or overdrive units, it may be necessary to adjust the position of the transmission with relation to the engine if the main drive gear will not enter the clutch disc. If the engine “hangs up”

FRONT NOTCH FOR LIFTING ENGINE LESS TRANSMISSION

REAR NOTCH FOR LIFTING ENGINE WITH TRANSMISSION



1217

100% SATISFACTION GUARANTEED

BUY IT NOW!

Click Here To Order

PayPal

Discover Cards

AMERICAN EXPRESS

MasterCard

VISA

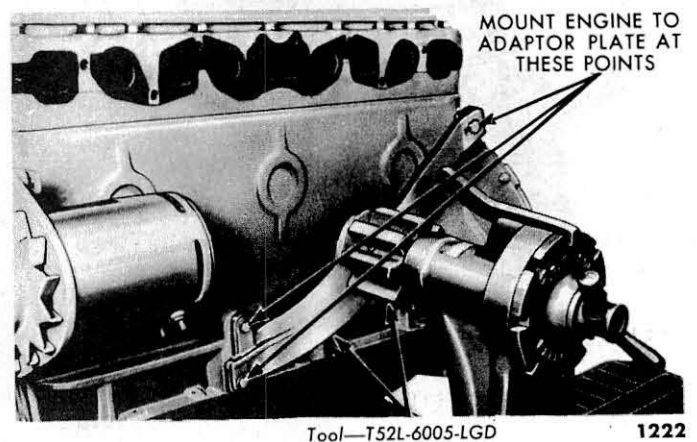

Fig. 4—Mounting Engine on Work Stand

after the gear enters, turn the crankshaft slowly (with the transmission in gear) until the drive gear splines mesh with the clutch disc.

Lower the engine (and transmission) until it rests on the front supports. Install the front support bolts. Remove the engine lift bracket, install the two cylinder head bolts, and tighten them to 65-70 foot-pounds.

Connect the muffler inlet pipe to the exhaust manifold. Connect the starter cable (except Fordomatic). Connect the accelerator linkage (except Fordomatic). Connect the choke wire and the windshield wiper hose. Connect the fuel pump flexible line.

Connect the generator wires, the engine temperature sending unit wire, the oil pressure sending unit wire, and the ignition switch to coil wire. Remove the tape seal from the carburetor and install the air cleaner.

Install the heater blower motor. Install the heater hose. Install the radiator and connect the radiator hose. Install the hood. Fill the cooling system and the crankcase.

(2) **CONNECT STANDARD OR OVERDRIVE TRANSMISSION.** Install the transmission to flywheel housing bolts and lock washers, then tighten them to 40-50 foot-pounds. Install the equalizer rod bushing on the rod and slide the support over the bushing. Install the screws and lock washers which attach the support to the flywheel housing and tighten the screws to 37-42 foot-pounds. Connect the clutch release rod and spring. Remove the jack supporting the transmission. Check the clutch pedal free play ($\frac{7}{8}$ - $1\frac{1}{8}$ inch). Adjust the free play if necessary.

(3) **CONNECT FORDOMATIC TRANSMISSION.** Install and connect the starter motor. Install the four lower converter housing to engine bolts and tighten them to 40-45 foot-pounds. Install the engine rear plate to converter housing bolts. Install the six converter to flexplate bolts. Install the converter housing lower access cover.

Install the upper converter housing to engine bolts and tighten them to 40-45 foot-pounds. Install the rubber plugs and replace the floor mat.

Secure the accelerator cross shaft bracket to the dash panel and connect the accelerator pedal shaft to the accelerator cross shaft. Connect the transmission throttle linkage to the cross shaft.

Remove the jack supporting the transmission.

(4) **CHECK ENGINE FOR LEAKAGE.** Warm up the engine and check for coolant leaks at all hose con-

or Overdrive Transmission," then proceed with "(3) Engine Removal." If the vehicle is equipped with Fordomatic, follow "(2) Preliminary Steps-Fordomatic," then proceed with "(3) Engine Removal."

(1) **PRELIMINARY STEPS—STANDARD OR OVERDRIVE TRANSMISSION.** Disconnect the driveshaft at the rear axle and pull the shaft out of the transmission extension. Remove the engine rear support to transmission extension bolts.

Disconnect the gearshift rods at the transmission. Disconnect the clutch pedal retracting spring and the clutch release rod. Remove the equalizer bar support to flywheel housing screws, remove the support and bushing, and let the equalizer bar and rod hang from the frame. Disconnect the speedometer cable.

NOTE: On the overdrive transmission, disconnect the manual control cable at the overdrive lever, remove the screw retaining the cable housing clip to the transmission, and pull the cable away from the transmission. Disconnect the two wires at the solenoid and the wire to the governor.

(2) **PRELIMINARY STEPS — FORDOMATIC.** Disconnect the manual control linkage at the transmission. Disconnect the driveshaft at the rear axle and pull it out of the transmission extension. Remove the two screws retaining the transmission to the rear support.

Disconnect the accelerator pedal shaft at the accelerator cross shaft and remove the screws retaining the cross shaft to the dash panel.

(3) **ENGINE REMOVAL.** Drain the coolant. Remove the hood and radiator. Remove the heater blower motor. Disconnect the heater hose at the engine. Disconnect the generator wires, engine temperature sending unit wire, oil pressure sending unit wire, and the ignition switch to coil primary wire.

Remove the air cleaner and tape the carburetor opening closed. Disconnect the choke wire at the carburetor. Disconnect the windshield wiper hose at the intake manifold. Disconnect the starter cable at the starter motor. Disconnect the accelerator linkage at the manifold bellcrank (except Fordomatic). Disconnect the fuel pump flexible line. Disconnect the muffler inlet pipe at the exhaust manifold and pull the pipe away from the manifold studs. Remove the engine front support bolts and washers.

Install the engine lift bracket (fig. 3). Use the rear notch in the bracket for proper engine balance and take up the load with a hoist.

Lift the engine and at the same time move it forward over the crossmember. Carefully raise the engine to remove it from the compartment. Do not let the engine swing against the grille or the compartment.

Install the engine on a stand using the adapter shown in fig. 4. Remove the lift bracket.

SATISFACTION 100% GUARANTEED

BUY IT NOW!

Click Here To Order

PayPal American Express Discover MasterCard VISA

d. Installation With Transmission.

If the vehicle is equipped with standard or overdrive transmission, follow steps (1) and (2). If the vehicle is equipped with Fordomatic, follow steps (1) and (3).

(1) **ENGINE INSTALLATION.** Install the engine lift bracket. Use the rear notch for proper engine balance and take up the load with a hoist. Remove the engine from the work stand. Lower the engine carefully into the compartment. Be sure that the transmission extension goes over the frame crossmember and is centered on the rear support. Lower the engine into position on the front supports. Install the front support bolts. Install the engine rear support to transmission bolts and lock washers. Tighten the bolts to 40-50 foot-pounds. Remove the engine lift bracket, install the two cylinder head bolts and tighten them to 65-70 foot-pounds.

Connect the muffler inlet pipe to the exhaust manifold. Connect the starter cable. Connect the accelerator linkage (except Fordomatic). Connect the choke wire and the windshield wiper hose. Remove the tape seal from the carburetor opening and install the air cleaner.

Connect the generator wires, the engine temperature sending unit wire, the oil pressure sending unit wire, and the ignition switch to coil wire.

Install the heater blower motor. Install the heater hose. Install the radiator and connect the radiator hose.

Install the hood. Fill the crankcase with the proper grade and amount of engine oil. Fill the cooling system.

(2) **CONNECT STANDARD OR OVERDRIVE TRANSMISSION.** Install the gearshift rods at the transmission. Install the equalizer rod bushing on the rod and slide the support over the bushing. Install the screws retaining the support to the flywheel housing and tighten the screws to 37-42 foot-pounds. Connect the clutch release rod and retracting spring. Check the clutch pedal free play ($\frac{7}{8}$ - $1\frac{1}{8}$ inch). Adjust the free play if necessary.

Install the speedometer cable.

NOTE: On the overdrive transmission, connect the manual control cable at the overdrive lever and secure the housing clip to the transmission. Connect the two solenoid wires and the governor wire. Check the operation of the manual control.

(3) **CONNECT FORDOMATIC TRANSMISSION.** Install the bracket retaining the accelerator cross shaft to the dash panel. Connect the accelerator pedal rod to the cross shaft.

Install the driveshaft. Connect the manual control linkage to the transmission. Make an operational check of the transmission to be sure the control linkage is in adjustment.

2. MANIFOLDS

A chamber is built into the intake manifold center section where the carburetor and exhaust manifold are attached. An exhaust control valve, located in the exhaust manifold, directs exhaust gases into this chamber when the engine is cold to provide for faster intake manifold warm-up.

NOTE: Do not remove manifolds when hot. They may warp and make reassembly difficult.

a. Removal.

Lift up the hood, then remove the air cleaner and the carburetor. Disconnect the throttle linkage and remove the bell crank from the manifold. Disconnect the windshield wiper vacuum line.

Disconnect the muffler inlet pipe from the exhaust manifold and pull the pipe away from the flange. Remove the manifold to head hold down bolts and lift the manifold assembly off the head. Remove the intake port ring inserts and gaskets.

Remove the nuts and the bolt holding the manifolds and separate the manifolds. A disassembled

Clean the outside of the manifolds with solvent.

c. Exhaust Thermostat Valve Replacement.

The exhaust thermostat valve does not require replacement unless it becomes inoperative.

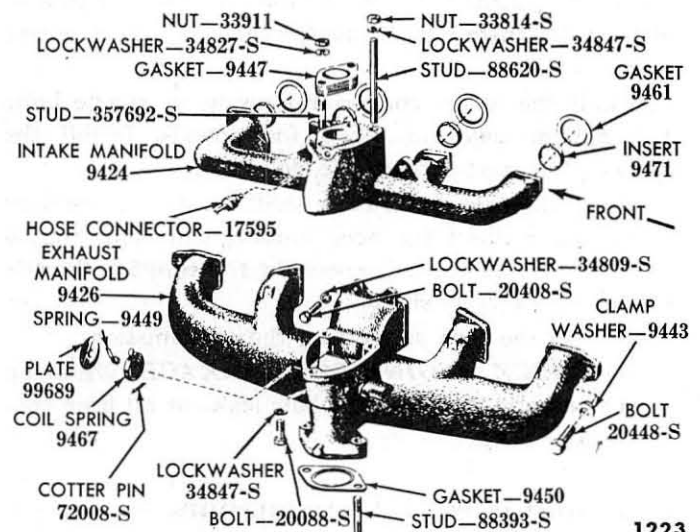

1223

Fig. 5—Manifold—Disassembled

100% SATISFACTION GUARANTEED

BUY IT NOW!

Click Here To Order

PayPal American Express Discover MasterCard VISA

manifolds and the

(1) **REMOVAL.** Before removing the valve assembly, note the position of the counterweight and of the thermostat spring slot with relation to the valve plate. Drive out the retaining pin and remove the counterweight from the shaft. Remove the cotter pin, washer, stop spring, and thermostat spring from the other end of the shaft. Cut the shaft on both sides of the valve. Remove the valve and the shaft pieces.

(2) **INSTALLATION.** Position a new valve inside the manifold. Lubricate a new shaft with graphite grease and insert through the valve. Rotate the shaft in the valve until the slot is positioned the same as it was originally. Weld the valve to the shaft.

Install the thermostat spring in the shaft slot, tighten the spring $\frac{3}{4}$ turn, and hook the open end of the spring over the stop pin. The spring should hold the thermostat open when the manifold is cold. Install the stop spring, washer, and cotter pin. Install the counterweight on the shaft in its original position. Drill through the shaft and install the retaining pin.

d. Inspection.

Inspect the manifolds for cracks, especially around the heat chamber in the intake manifold. Make sure all gasket surfaces are free from projections that may inter-

fere with sealing. Replace the manifold if it is cracked or otherwise damaged.

e. Installation.

Place the intake manifold over the studs on the exhaust manifold. Install the lock washers, nuts, and bolt and tighten the nuts and bolt finger tight. Install new inserts and gaskets in the intake manifold, coat the surfaces lightly with graphite grease, then position the manifold assembly on the cylinder head. Install the manifold hold down bolts and lock washers. Tighten the bolts to 23-28 foot-pounds, tightening from the center to the ends. Tighten the nuts and bolt retaining the manifolds together to 23-28 foot-pounds. Install a new exhaust outlet flange gasket and slide the muffler inlet pipe over the studs in the exhaust manifold. Install the nuts and lock washers and torque the nuts to 23-28 foot-pounds.

Connect the accelerator linkage to the bellcrank on the manifold. Install the carburetor and connect the linkage to the carburetor and bellcrank. Install the windshield wiper vacuum line. Install the air cleaner. Warm up the engine and check the idle adjustment.

NOTE: On Fordomatic units, check the throttle linkage for correct adjustment.

3. CYLINDER HEAD

The cylinder head is cast from the same high grade iron as is used for the cylinder block. Cylinder head distortion is kept to a minimum because the expansion and contraction due to temperature change is the same for both head and block. The head carries the valves and valve rocker arm mechanism and the manifold assembly.

Procedures given below cover only the removal, cleaning, inspection, and installation of the cylinder head. Disassembly of the cylinder head and valve mechanism is covered under "Valves and Valve Mechanism" later in this Chapter.

a. Removal.

Open the hood, then drain the cooling system. Disconnect the radiator and heater hose at the cylinder head outlet elbow. Disconnect the windshield wiper vacuum line from the manifold. Remove the air cleaner. Remove the valve chamber cover.

Disconnect the fuel line at the fuel pump and carburetor. Disconnect the oil line at the distributor. Disconnect the two lines. Disconnect the screws retaining the coil to hang

from the distributor. Disconnect the engine temperature sending unit wire.

Remove the cap screw and clip from No. 6 rocker arm support bracket. Pull the oil feed line out of the bracket, then pull it out of the block with pliers (fig. 6). Do not damage the line with the pliers.

Loosen all rocker arm adjusting screws to remove the valve spring load from the rocker arms. Slide the rocker arms away from the push rods and remove the rods (fig. 7).

REMOVE SCREW

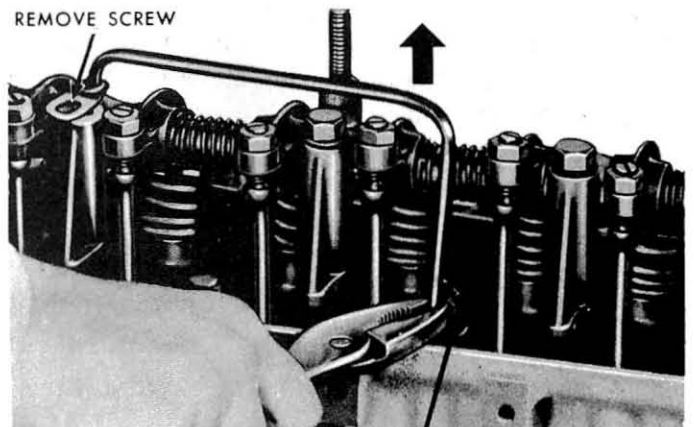

PRY UP OIL LINE WITH PLIERS

1224

Fig. 6—Removing Oil Line

NOTE: *The rocker arms at each end of the engine cannot be moved laterally. Leave the two end push rods in place.*

Identify the push rods so they can be reinstalled in their original position.

Remove the manifold hold down bolts and pull the manifold assembly away from the head allowing it to be supported by the muffler inlet pipe. Install the cylinder head holding fixture brackets (which are shown installed on the head in fig. 10) for convenience in lifting the head off the block, and to protect the gasket surfaces of the head.

Remove all cylinder head bolts. Install the guides shown in fig. 8. Lift the cylinder head assembly off the engine.

CAUTION: *Do not pry the head loose with a screwdriver or wedge. The gasket surfaces of the head and block have a finished surface and must not be scratched or gouged.*

b. Cleaning.

Remove the spark plugs. Remove carbon deposits from the combustion chambers and valve heads with a scraper and a stiff wire brush. Be careful not to scratch the gasket surface of the head. Clean out rust and dirt from the water passages.

c. Inspection.

Check the head for cracks and warped gasket surfaces. Check to see that all water passages are open. Make sure the gasket surfaces of both head and block are clean and free from scratches or projections (at screw holes). Smooth off any projections or scratches with an oil stone.

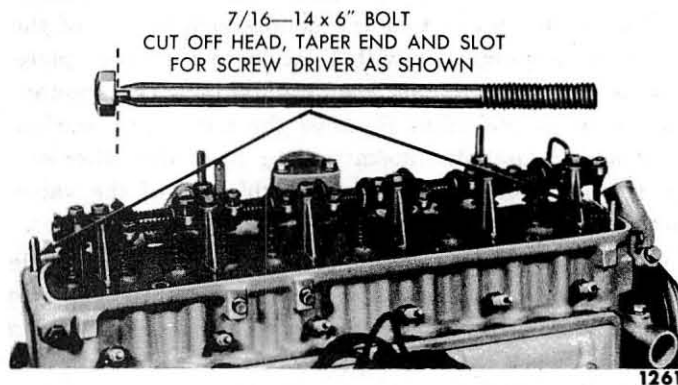

Fig. 8—Cylinder Head Guides

d. Installation.

Apply a coating of cylinder head gasket sealer (8A-19554) to both sides of the new head gasket. Use the brush furnished to spread the sealer evenly over the entire gasket surface. Position the gasket over the guide studs on the cylinder block. Lift the cylinder head over the guides and the two end push rods and slide the head down carefully, guiding the two end push rods through the head.

Before installing the cylinder head bolts, coat the threads of each bolt with a small amount of water resistant sealer. Install two bolts at opposite ends of the head to hold the head and gasket in position. Remove the guides, install the remaining bolts, and tighten all the bolts to 65-70 foot-pounds in the order shown in fig. 9. Remove the cylinder head holding fixture brackets.

Remove the tappet chamber cover plates. Clean the ends of the push rods and install the rods, centering the lower ends in the tappets and the upper ends on the rocker lever adjusting screws. Install the long end of the rocker shaft oil feed line in the cylinder block. Be sure the grommet seal is pressed evenly into the recess in the block. Install the short end of the line in No. 6 rocker shaft bracket. Install the clip and the bracket retaining screw. Tighten the screw to 45-55 foot-pounds.

Install the tappet cover plates and tighten the screws to 5-8 foot-pounds from the center outward. Adjust the valve-rocker arm clearance for each valve. (0.015 inch intake and exhaust—cold setting).

Install the intake port rings, install new gaskets in the intake ports, and install the manifold assembly.

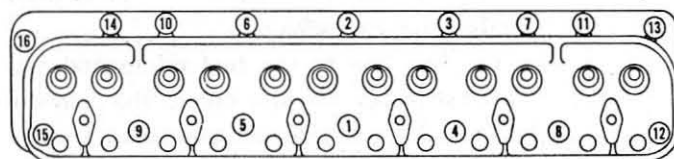

Fig. 9—Cylinder Head Bolt Tightening Sequence



1239



BUY IT NOW!

Click Here To Order



Install the ignition coil. Install the spark plugs and tighten them to 25-30 foot-pounds torque. Connect the spark plug wires. Install the fuel line and distributor vacuum line. Connect the engine temperature sending unit wire.

Install the radiator hose and fill the cooling system according to the prevailing temperature. Install the air cleaner. Run the engine until it warms up and check for coolant leakage or gas leakage past the cylinder head gaskets.

4. VALVES, VALVE MECHANISM, AND VALVE LASH ADJUSTMENT

Procedures covering repair and replacement of valves and valve mechanism and adjustment of valve lash are given below.

The procedures include cylinder head disassembly and assembly.

Valve guides are an integral part of the cylinder head. Valves with 0.003, 0.015, and 0.030 inch oversize stems are available for service when the valve guides become worn or scored.

a. Cylinder Head Disassembly.

Remove the cylinder head from the engine. Remove the cap screws retaining the rocker shaft brackets to the head and remove the shaft assembly.

The cylinder head is shown mounted in the holding fixture in fig. 10.

Pull the oil drain line and clip out of the No. 1 bracket. Remove the cotter pins at each end of the rocker arm shaft and remove the flat washers and spring washers. Slide the rocker arms, springs, and brackets off the shaft. Be sure to identify the various parts so they can be replaced in their original position. The rocker mechanism is shown disassembled in fig. 11.

Clean carbon out of the combustion chambers before removing valves. Compress the valve springs with the tool shown in fig. 12, remove the valve stem locks, and release the springs. Remove the sleeve, valve spring cap retainer, spring, and valve. Discard the intake valve seals. Identify all valve parts so they can be replaced in the same position from which they were removed.

b. Valve and Seat Refacing.

A rotatable type valve (fig. 13) is used for both intake and exhaust valves. The valve tends to rotate slightly each time it is lifted from the seat. The valve and seat should be lightly lapped after regrinding or installing new valves. Use a medium grade lapping

After the engine reaches normal operating temperature, check the valve lash while the engine is idling. Reset the valve lash if necessary.

Coat one side of the valve chamber cover gasket with oil resistant rubber cement (M-2G4) and lay the cemented side of the gasket in place in the cover. Install the valve chamber cover making sure it seats evenly all around the head. Install and tighten the retaining nuts to 8-10 foot-pounds torque. Be sure the rubber washers are in place in the cover.

Check the valve for a burned or warped head or a warped stem. Discard any defective valves.

(2) **VALVE GUIDE INSPECTION AND REPAIR.** Measure the valve guide diameter (fig. 14) and the valve stem diameter. If the clearance is more than 0.004 inch for the intake or more than 0.005 inch for the exhaust valves, ream out the guide and install the next oversize valve. Use the piloted reaming tool shown in fig. 15. Be sure to clean out all chips and metal particles. Regrind the valve seats when the guides are reamed.

NOTE: *The valve guide reamers are piloted to fit a standard hole (0.003 inch oversize reamer), 0.003 inch oversize hole (0.015 inch reamer), and a 0.015 inch oversize hole (0.030 inch reamer). Be sure to use the reamers in sequence when reaming from standard to oversize holes.*

(3) **REFACING VALVES.** Grind the valve face at a 45° angle on a valve refacing machine as shown in fig. 16. Grind off only enough stock to remove pits or grooves from the valve face. If the edge of the valve head is less than 1/32 inch thick after grinding, replace the valve. Grind the valve stem ends if they are grooved or scored. Do not grind more than 0.010 inch from the stem end. Check the valve face runout. If it exceeds 0.002 inch, regrind the face. If it still exceeds 0.002 inch after regrinding, discard the valves.

(4) **VALVE SEAT REFACING.** Clean the valve seats with a wire brush to remove all carbon. Clean the

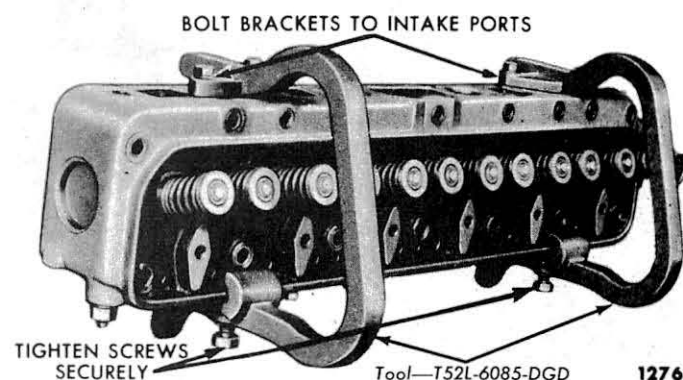

Fig. 10—Cylinder Head Holding Fixture

100% SATISFACTION GUARANTEED

BUY IT NOW!

Click Here To Order

INSPECTION. m the head and m the valve stem

PayPal American Express Cards DISCOVER NOVUS MasterCard VISA

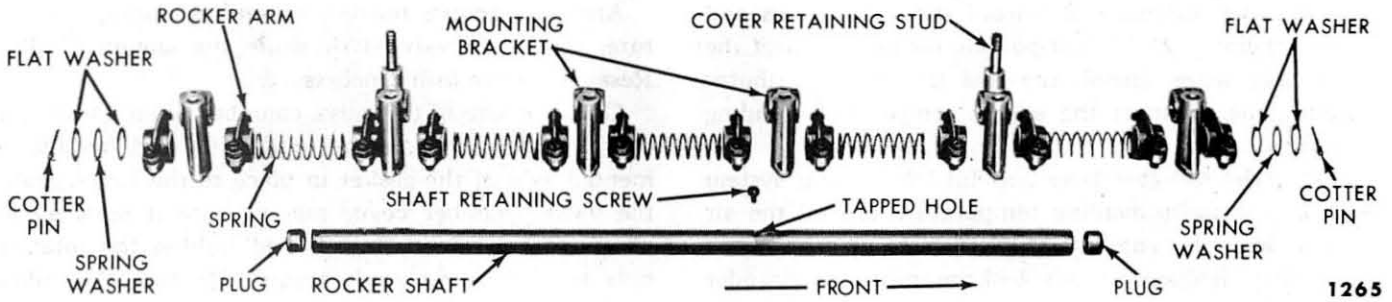

Fig. 11—Rocker Mechanism—Disassembled

valve guides with a guide cleaner. Grind the seats with a valve seat grinder. Remove only enough stock to clean up pits and grooves in the seat. If the valve seat width is more than 0.070-0.080 inch (intake) or 0.095-0.105 inch (exhaust) remove just enough stock from the top and bottom edge of the seat to reduce the width (see fig. 17). Use a 30° angle wheel to remove stock from the bottom of the seat and a 60° angle wheel to remove stock from the top. Keep the seat as near to the center of the valve face as possible.

Check the valve seat runout with a runout gauge as shown in fig. 18. The seat runout should not exceed 0.003 inch.

(5) **TEST VALVE SPRING PRESSURE.** Check the valve spring pressure with the tool shown in fig. 19. The valve springs should exert a pressure of 54-62 lbs. when compressed to a length of 1.821 inches or 124-140 lbs. when compressed to 1.505 inches (A 10% loss in pressure is allowable in service).

c. Rocker Arm, Shaft, and Push Rod Inspection.

Check the rocker arm bore diameter with a telescope gauge and micrometer. Check the rocker arm shaft diameter at the location of the rocker arms. If the

clearance between the shaft and rocker arms exceeds 0.007 inch, replace the shaft and rocker arms. Check the rocker arm adjustment screws and lock nuts for stripped threads, and the ball end of the screw for nicks and scratches. Replace any scratched rocker arm screws or lock nuts with stripped threads.

Check the push rods by rotating them between cup and ball centers with a dial indicator on the rod. If the total indicator runout exceeds 0.020 inch, replace the rods. Do not attempt to straighten push rods. Check the ball end and socket ends to make sure they are smooth. If either end is nicked or scratched, replace the rod.

NOTE: A rough check for bent push rods can be made while they are installed in the engine. Rotate the push rods (valves closed) and observe the runout. If any runout is observed be sure to check the push rod with an indicator as described above.

d. Cylinder Head Assembly.

Oil the moving parts with engine oil. Lay out the shaft and rocker mechanism parts as shown in fig. 11. Install a plug in each end of the shaft, cup side out. Do notpeen these plugs to make them tight. Install a flat washer, spring washer, another flat washer, and a cotter pin in one end of the shaft. Install the parts in the order shown in fig. 11. Install the screw retaining the shaft to the No. 3 support bracket. An assembled view of the rocker arm, shaft, and bracket is shown in fig. 20.

Install a valve in the port from which it was removed. Install the valve spring with the closed coil next to the head. Install the valve spring seat and sleeve. Compress the spring, install the seal, and install the locks as shown

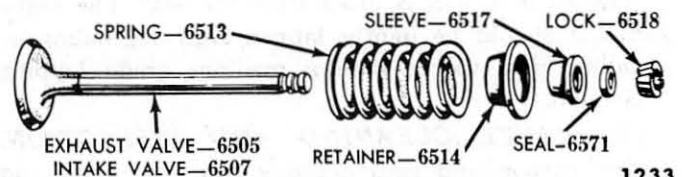

Fig. 13—Valve and Related Parts

Locks

1233

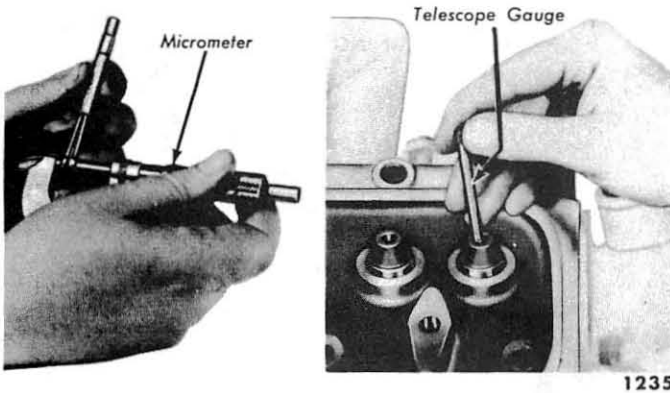

Fig. 14—Measuring Valve Guide

in fig. 12. Repeat the operation for each valve. Be sure to use new seals on the valves.

Place the rocker arm assembly on the head, install the four center bracket screws, and torque them to 45-55 foot-pounds. Install the oil drain line, clip, and retaining screw on No. 1 bracket and torque the screw to 45-55 foot-pounds.

NOTE: The No. 6 bracket retaining screw is installed when the head is replaced on the engine.

Replace the cylinder head on the engine.

e. Valve Lash Adjustment.

Valve lash is adjusted by means of a ball end set screw and lock nut at the push rod end of the rocker arm.

If the cylinder head has been removed and reinstalled or the rocker mechanism removed and installed, it will be necessary to make a preliminary valve lash adjustment before starting the engine. If the valve lash adjustment is made for the purpose of engine tune-up, omit step (1) and proceed with step (2).



Fig. 16—Valve Refacing

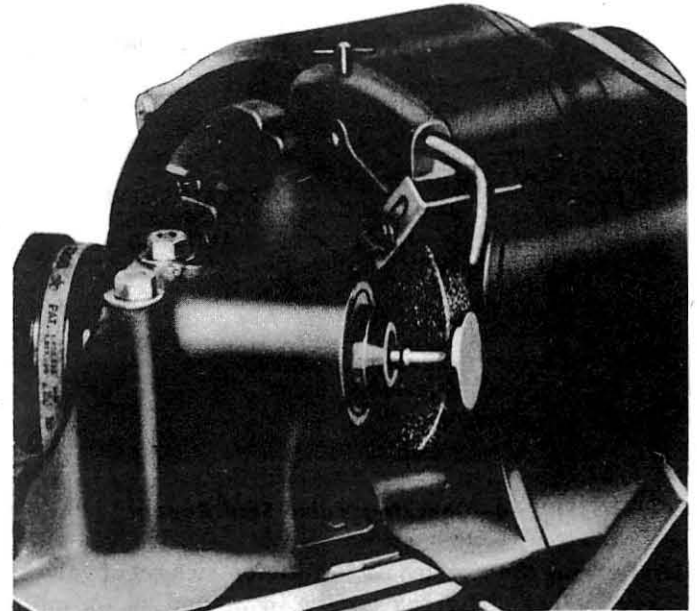

Fig. 17—Correct Valve Seat Width

(1) **PRELIMINARY ADJUSTMENT.** Remove the valve chamber cover. Rotate the crankshaft until No. 1 piston is near top center at the end of the compression stroke.

NOTE: No. 1 piston is near T.C. compression stroke when both of its valves are closed and the timing mark on the crankshaft damper is in line with the pointer.

Check the intake and exhaust valve lash for No. 1 cylinder with a 0.015 inch feeler gauge (fig. 21). If the lash is not 0.015 inch, loosen the adjusting screw lock nut and adjust the screw until this clearance is obtained. Tighten the lock nut without moving the adjusting screw.

Make two chalk marks on the crankshaft damper 120° each way from the timing mark (120° represents 1/3 turn of the crankshaft or 1/3 of the way around the damper circumference).

Turn the crankshaft 1/3 turn in the direction of rotation and check the valve lash of No. 5 cylinder. Repeat this operation for No. 3, No. 6, No. 2, and No. 4 cylinder.

100% SATISFACTION GUARANTEED

BUY IT NOW!

Click Here To Order

PayPal American Express Discover MasterCard VISA

1238

1236

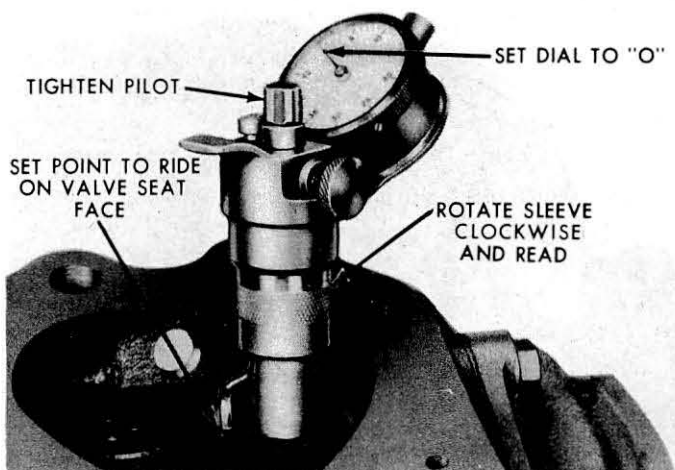

1237

Fig. 18—Checking Valve Seat Runout

ders, turning the crankshaft $\frac{1}{3}$ turn for each set of valves.

(2) **FINAL ADJUSTMENT.** Run the engine until it reaches normal operating temperature, then check the valve lash. The lash should be 0.015 inch, and may be

5. OIL PAN, FILTER, OIL PUMP, AND PRESSURE RELIEF VALVE

Procedures for repair and replacement of the oil pan, filter, oil pump, and pressure relief valve are presented here under self-explanatory headings.

a. Oil Pan.

Removal, cleaning, inspection, and installation proce-

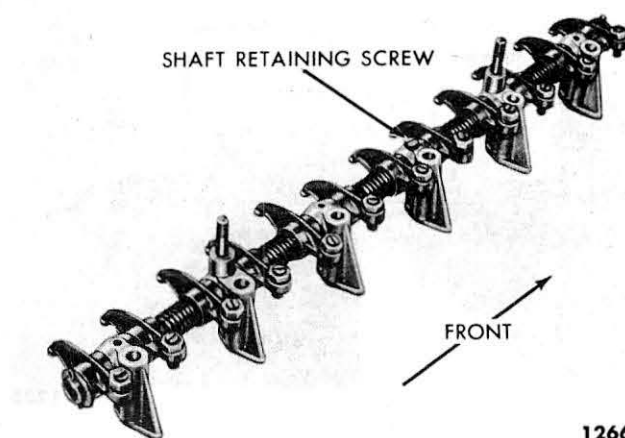

1266

Fig. 20—Rocker Arm and Shaft Assembly

checked with the engine idling or with the procedure outlined above. Replace the valve chamber cover with a new gasket cemented to the cover only. Do not exceed 8-10 foot-pounds torque on the cover nuts or the cover will be distorted.

dures for the oil pan are given under descriptive headings. The oil pan is shown in fig. 22.

(1) **REMOVAL.** Drain the crankcase. Drain the coolant from the engine and the radiator. Disconnect the upper and lower radiator hose at the engine. Remove the bolts which attach the engine front supports to the frame. Raise the front end of the engine about 2 inches.

Pull the dip stick out of the tube. Remove the oil pan retaining screws and remove the pan and gasket.

(2) **CLEANING.** Wash the pan in solvent and dry

1263

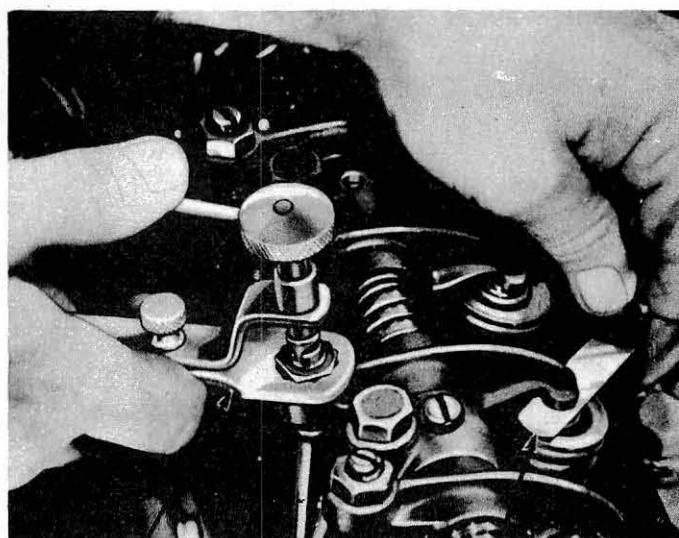

1240

Fig. 21—Checking Valve Lash

it thoroughly. Brush any dirt or metal particles from the inside of the pan. Scrape all the old gasket material from the gasket surface of the pan.

(3) **INSPECTION.** Check the pan for cracks, holes, or warping at the gasket surface. Repair any cracks or holes. Replace the pan if repairs cannot be made.

(4) **INSTALLATION.** Clean the gasket surface of the block thoroughly. File off any burrs around the threaded bolt holes. Tie the oil pan gasket to the pan with string through two screw holes at each end of the pan.

Hold the pan in place and install one screw, finger tight, at each end of the pan. Remove the string ties and install the remaining screws. Tighten the screws from the center outward in each direction with a large screwdriver. After tightening all screws, recheck the center screws.

Lower the engine and install the front mounting bolts. Connect the radiator hose and fill the cooling system.

Fill the crankcase with the proper grade and quantity of engine oil. Run the engine until it is warmed up and check for oil leakage and coolant leakage.

b. Oil Filter.

The full-flow type oil filter filters the entire output of the pump before the oil enters the lubrication system of the engine. A built in by-pass provides oil to the system in case the filter element becomes clogged. The by-pass is built into the hollow center bolt and consists of a spring loaded valve. When the element is clean and oil will flow through it, the pressure difference between the outside and inside faces of the valve is not great enough to overcome the spring pressure behind the valve. When the element is dirty and will not permit a sufficient flow of oil, the pressure inside the center bolt drops and the pressure difference on the valve faces is enough to cause the valve to open. Oil then by-passes the element maintaining a supply to the lubrication system.

(1) **REMOVAL.** Place a drip pan on the floor directly under the filter. Remove the through bolt retaining the filter to the block. Remove the filter assembly and gasket.

(2) **DISASSEMBLY.** Remove the filter element, gasket, spring seat, and spring from the housing. Remove the center bolt and fiber gasket. The filter is shown disassembled in fig. 23.

(3) **CLEANING.** Wash all parts in solvent. Make sure all openings in the center bolt are clean.

(4) **ASSEMBLY.** Use new gaskets when assembling the filter. Place a new fiber gasket on the center bolt, then install the bolt in the cover. Install the spring, spring seat, new neoprene gasket, and filter element on the bolt. Be sure the seat is fastened to the spring with the tangs.

NOTE: *Be sure there is only one neoprene gasket between the spring seat and the filter element. If two gaskets are used, the oil by-pass port may be partially covered when the filter element becomes clogged.*

(5) **INSTALLATION.** Install a new gasket in the block recess.

NOTE: *Do not use any sealing compounds.*

Install the filter assembly against the gasket, tightening the bolt just enough so the filter housing touches the gasket. Rotate the housing slightly in each direction to make sure it seats evenly against the gasket. Tighten the center bolt to 20-25 foot-pounds.

Start the engine and allow it to idle until lubrication is fully established, then increase engine speed and check for leaks around the filter. Check the oil level in the crankcase and add oil if necessary.

CAUTION: *It is important that the filter housing does not leak because the full output of the oil pump passes through the filter and oil inside the filter is at the same pressure as the lubrication system.*

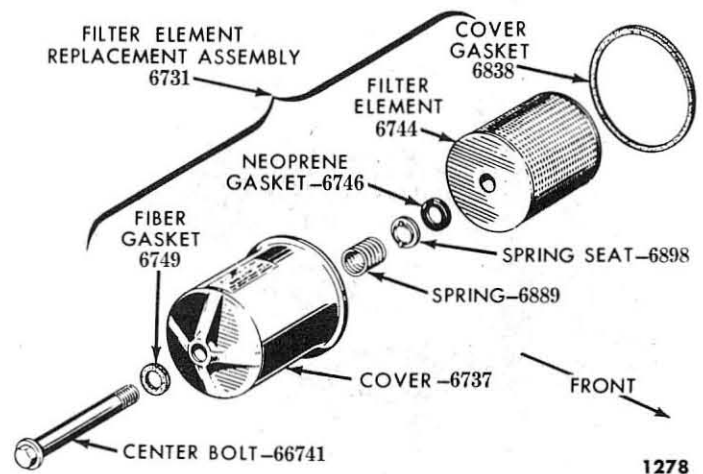

Fig. 23—Oil Filter Disassembled

c. Oil Pump and Pressure Relief Valve.

A gear type oil pump is mounted on the inner side of the crankcase in line with the distributor. The pump is driven by means of a slot in the distributor shaft and a tang on the end of the oil pump shaft. A pressure relief valve is incorporated in the oil pump housing.

Oil pump removal, disassembly, cleaning, inspection, assembly, and installation procedures are presented below. The pressure relief valve is covered in the disassembly and assembly procedures for the pump.

(1) **REMOVAL.** Drain the oil and remove the oil pan. Remove the distributor. Remove the two nuts and lock washers retaining the pump to the cylinder block. Remove the pump and gasket.

NOTE: *If the oil pump mounting bolts turn in the block, remove the oil filter to gain access to the pump mounting bolt located inside the filter housing, (fig. 24).*

(2) **DISASSEMBLY.** Remove the screen assembly retaining screws, the screen assembly, and gasket. Remove the cover retaining screws, cover, and gasket. Push the pump drive shaft and drive gear assembly from the pump housing. Remove the driven gear. Remove the oil pressure relief valve plug, spring, and plunger.

Remove the snap wire retaining the pump screen and remove the screen from the housing. The oil pump and screen are shown completely disassembled in fig. 25.

(3) **CLEANING.** Wash all the parts in solvent and dry them thoroughly. Blow out the inside of the pump housing to make sure no dirt or metal particles remain. Remove all old gasket material from the pump body and cover plate.

(4) **INSPECTION.** Check the pump housing for cracks or excessive wear. The pump shaft should have a free running fit without excessive play in the pump body (0.0005 to 0.0025 inch clearance). Check the pump

gear teeth for scratches and wear. Measure the clearance between the outside diameter of the gears and the pump housing. It should be no greater than 0.005 inch. Check the compression of the relief valve spring. It should be 9.82 pounds plus or minus 0.12 pounds when the spring is compressed to 1.56 inches. Replace any worn or defective parts.

(5) **ASSEMBLY.** Apply a light coat of engine oil to all moving parts. Place the snap ring on the groove on the upper end of the lower drive shaft. Snap the tang of the intermediate shaft into the fork of the lower shaft, making certain the snap ring is seated in the groove in both shafts. Slide the drive gear and shaft assembly into the housing. Install the pump driven gear, the cover plate gasket, the cover plate, and the retaining screws. Torque the screws to 10-12 foot-pounds. Install the pressure relief valve plunger, spring, and plug. Tighten the plug to 33-38 foot-pounds.

Install the screen in the screen cover and secure it with the snap wire. Install the gasket, screen and cover assembly, and retaining screws. Tighten the screws to 10-12 foot-pounds. Rotate the pump shaft by hand to make sure it turns freely.



100% SATISFACTION GUARANTEED

BUY IT NOW!

Click Here To Order

ING BOLTS 1228

ing Bolts

PayPal, American Express, Discover, MasterCard, VISA

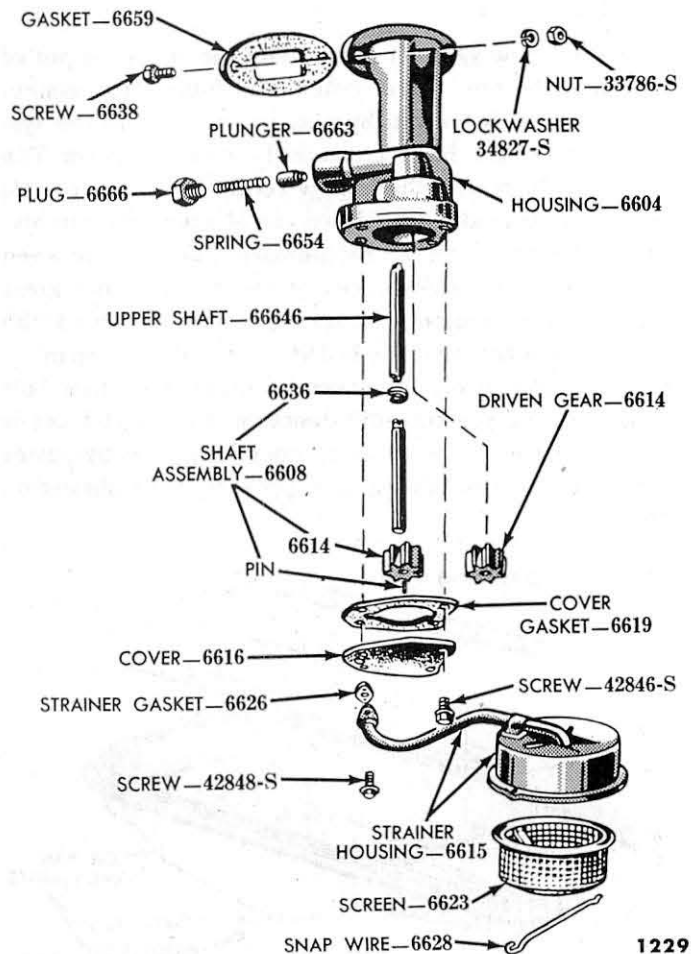

Fig. 25—Oil Pump Disassembled

(6) **INSTALLATION.** Place a new gasket on the retaining bolts and slide the pump mounting flange over the retaining bolts. Install the lock washers and nuts. Torque the nuts to 30-35 foot-pounds.

Install the oil filter and the oil pan. Install the distributor. Fill the crankcase with the proper grade and quantity of oil.

Run the engine to check for proper pump operation.

6. CRANKSHAFT DAMPER

The 6-cylinder engine is equipped with either a rubber-type damper (fig. 26) or a viscous damper which is keyed to the crankshaft and retained with a cap screw and washer. Two threaded bolt holes are provided in the damper to facilitate removal.

with the tool shown in fig. 27.

a. Removal.

Remove the radiator. Remove the generator belt. Remove the retaining bolt and washer from the end of the crankshaft. Remove the damper from the crankshaft

b. Installation.

Lubricate the crankshaft with an oil-white lead mixture. Line up the damper keyway with the key on the crankshaft and start the damper on the shaft. Press the damper on the shaft (fig. 28). Install the washer and retaining bolt and torque the bolt to 45-55 foot-pounds. Install the generator belt and adjust the belt tension. Install the radiator.

7. CYLINDER FRONT COVER AND OIL SEAL

The engine front cover is a one piece steel stamping retained to the cylinder block by ten slotted head screws and to the oil pan by two screws. Two dowels are used to locate the cover on the block. The ignition timing pointer is spotwelded to the cover.

Procedures for cover removal, inspection, oil seal replacement, and installation are given below.

oil pan to the cover and loosen the remaining screws slightly. Remove the cover retaining screws, the cover, and gasket.

a. Removal.

Remove the radiator. Remove the crankshaft damper. Remove the two screws that retain the front end of the

b. Inspection.

Check the cover for cracks and for damage to the gasket surfaces. Repair any cracks or replace the cover if repairs cannot be made.

c. Oil Seal Replacement.

Drive out the old seal with a pin punch. Clean out the seal recess in the cover and install a new seal with the tool shown in fig. 29. Coat the new seal with grease

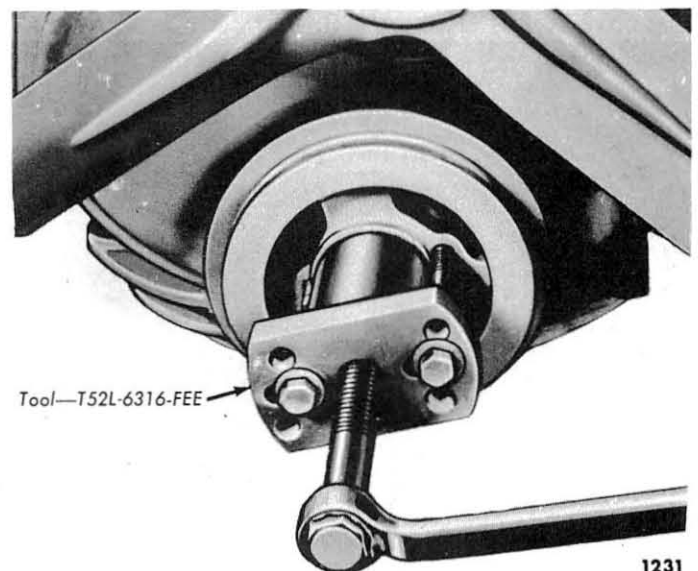

Fig. 27—Damper Removing Tool

100% SATISFACTION GUARANTEED

BUY IT NOW!

Click Here To Order

PayPal American Express Discover MasterCard VISA

to reduce friction when installing. Drive the seal in until it is fully seated in the recess. Check the seal to be sure the spring did not come out during installation.

d. Installation.

Position a new gasket on the block, place the cover

on the cylinder block, and install the retaining screws. Tighten the cover retaining screws evenly. Install the damper. Install the radiator. Install the two screws retaining the oil pan to the front cover and tighten all oil pan screws evenly working from the center outward in each direction.

8. CAMSHAFT SPROCKET, CAMSHAFT, AND BEARINGS

The camshaft is supported by four bearings which are pressed into the block. It is driven by a sprocket and timing chain in mesh with a sprocket on the crankshaft. An eccentric on the camshaft contacts the fuel pump rocker arm which operates the fuel pump. The camshaft sprocket is keyed to the camshaft and is retained by a bolt and washer. Camshaft thrust is controlled by a plate bolted to the front of the block. The plate is located between the camshaft sprocket and a shoulder on the camshaft.

Procedures for removal, inspection, and installation of the camshaft sprocket, timing chain, camshaft, and bearings are given below. The procedures are written to include the steps necessary for removal and installation when the engine is in the vehicle. If the engine is removed, eliminate any steps not applicable. The camshaft and related parts are shown in fig. 30.

a. Camshaft Sprocket and Timing Chain.

To make the sprocket and chain accessible, remove the radiator, crankshaft damper, and engine front cover.

(1) **INSPECTION.** Check the wear on the timing chain and camshaft sprocket by taking up the slack on the driving side of the chain then measuring the deflection on the slack side of the chain (fig. 31). Total outward deflection should not be more than $\frac{1}{2}$ inch. If excessive slack is indicated it will be necessary to re-

place the sprockets and chain. Check the camshaft sprocket for broken or chipped teeth.

(2) **REMOVAL.** Before removing the camshaft sprocket, it is advisable to align the timing marks as shown in fig. 32.

Remove the camshaft sprocket retaining bolt and washer. Slide the camshaft sprocket, timing chain, and crankshaft sprocket forward until the camshaft sprocket comes off the camshaft. Do not lose the key from the camshaft.

(3) **INSTALLATION.** Place the timing chain over the crankshaft sprocket, and insert the camshaft sprocket in the timing chain so the timing marks of both sprockets and the chain are aligned (fig. 32). Align the key in the camshaft with the camshaft sprocket keyway and slide the assembly into position. Recheck the timing. Install the washer and retaining bolt. Tighten the bolt to 45-50 foot-pounds.

Install the cylinder front cover, crankshaft damper, and radiator.

b. Camshaft.

It will be necessary to replace the camshaft when the lobes are worn to such an extent that valve lift is less than 0.335 inch for intake and 0.330 inch for exhaust. Check valve lift with a dial indicator as shown in fig. 33. The valve lash must be zero.

(1) **REMOVAL.** Remove the grille and radiator. Re-

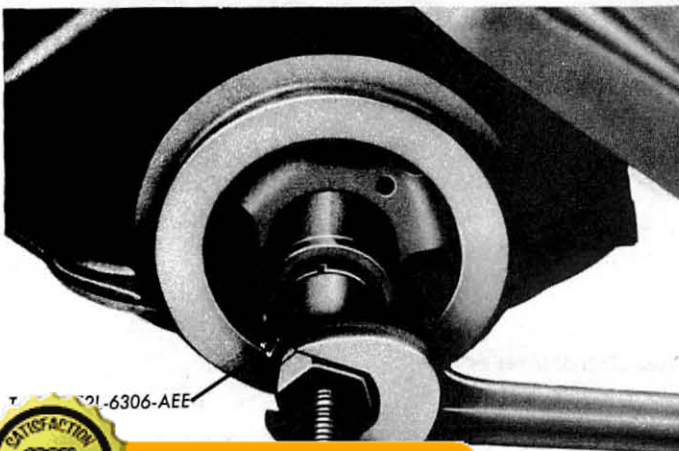

1232



1277

Fig. 29—Installing Oil Seal

121-6306-AEE

100% SATISFACTION GUARANTEED

BUY IT NOW!

Click Here To Order

PayPal | American Express | Discover | MasterCard | VISA

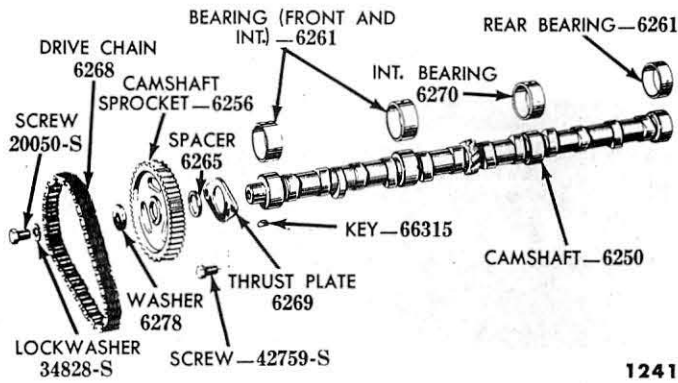

Fig. 30—Camshaft and Related Parts

move the crankshaft damper and cylinder front cover. Remove the rocker arm cover and the push rod cover. Remove all push rods. Lift the tappets and hold them in the up position with spring clothespins or rubber bands. **NOTE: If the engine is removed from the vehicle, invert it to keep the tappets away from the camshaft. Be sure oil pan is either drained or removed before inverting engine.**

Remove the distributor. Remove the fuel pump. Remove the camshaft sprocket and timing chain. Remove the screws retaining the thrust plate and remove the thrust plate. Carefully pull the camshaft out of the engine.

CAUTION: Do not gouge the camshaft bearings with the cam lobes when removing the camshaft.

(2) **INSPECTION.** Check the camshaft journals

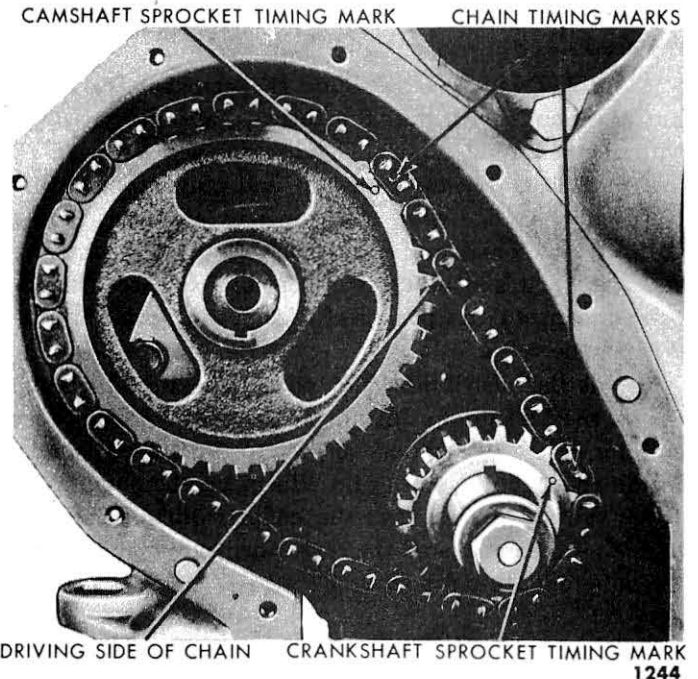

Fig. 32—Aligning Timing Marks

for grooves or scratches. Measure the journal diameter for wear and out of round. Replace the camshaft if the journals are more than 0.001 inch out of round. Measure the front camshaft bearing inside diameter. The difference in measurement between the bearing and camshaft journal (amount of clearance) should be 0.001-0.003 inch for a new camshaft and bearings, and not over 0.005 inch for a used camshaft and bearings. If the front bearing is worn excessively, it can be assumed that all bearings are worn to this extent.

Check the fuel pump eccentric for wear. Inspect the distributor drive gear for worn or damaged teeth.

Replace the camshaft or bearings if any of the above conditions exist.

Inspect the wear pattern on the lift portion of the cam lobes. The surface of the cam is tapered slightly to aid in tappet rotation. If the taper is worn off over more

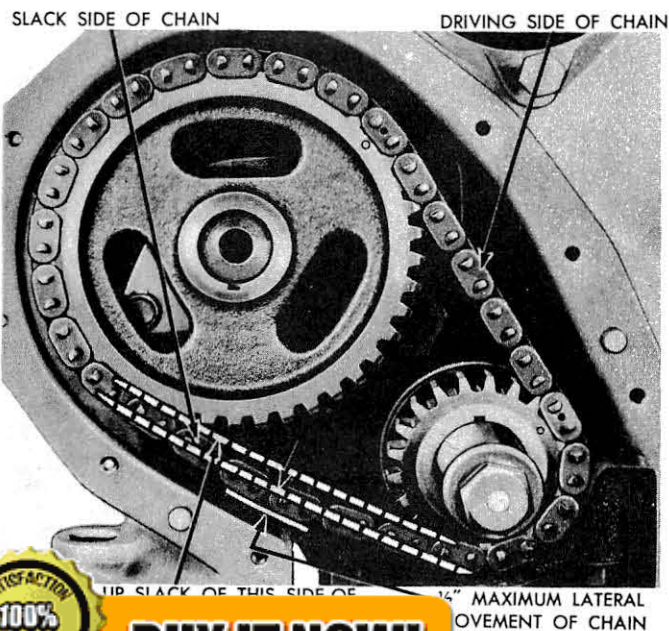

1355

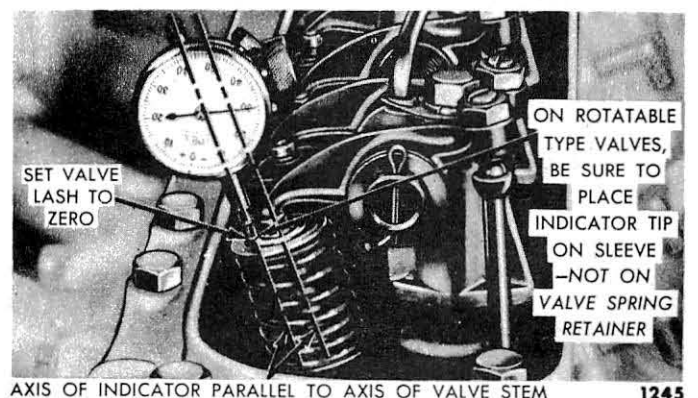

1245

Fig. 33—Valve Lift Measurement

100% SATISFACTORY GUARANTEED

BUY IT NOW!

Click Here To Order

PayPal, American Express, Discover, MasterCard, VISA

than half the face of the cam, the camshaft must be replaced.

(3) **INSTALLATION.** Slide the camshaft carefully into the bearings. Install the thrust plate and secure it with the retaining screws. Tighten the screws to 15-18 foot-pounds. Check the camshaft end play. It should be 0.003-0.006 inch. Install the camshaft sprocket, timing chain, front cover, and crankshaft damper. Install the generator belt and adjust belt tension. Release the tappets and install the push rods. Make an initial adjustment of the valve lash.

Install the distributor and adjust the initial timing. Install the fuel pump. Install the tappet chamber cover and torque the retaining screws to 8-10 foot-pounds. Install the radiator and grille. Warm up the engine and check the valve lash with the engine idling. Reset the lash, if necessary. Install the rocker arm cover and torque the nuts to 8-10 foot-pounds.

c. Camshaft Bearing Replacement.

Replace camshaft bearings if the clearance exceeds 0.005 inch.

It will be necessary to remove the engine from the vehicle to replace camshaft bearings. The bearings are available pre-finished to size for standard and 0.015 inch undersize camshaft journal diameters.

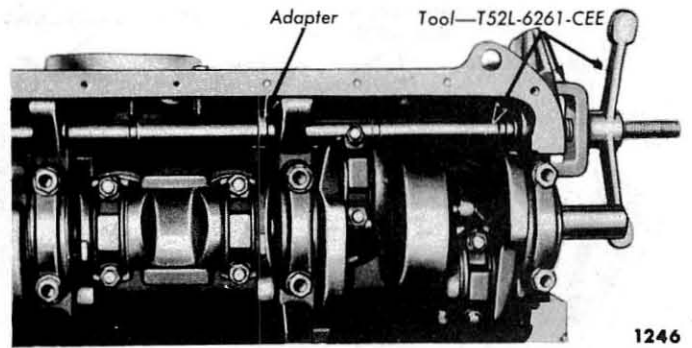

Fig. 35—Removing or Installing Camshaft Bearings

The bearing insert for No. 1 bearing is not interchangeable with the No. 2, 3, and 4 bearings.

(1) **REMOVAL.** Remove the camshaft. Drill a 1/2" hole in the plug at the rear camshaft bearing bore. Use the tool shown in fig. 34 to remove the plug. Remove the camshaft bearings with the tool shown in fig. 35.

(2) **INSTALLATION.** Position the bearing at the bearing bore and press it in place as shown in fig. 35. Be sure the oil hole in the bearing lines up with the oil hole in the bore.

Clean out the plug recess in the rear bearing bore. Coat the rim of a new plug lightly with sealer. Install the plug with the tool shown in fig. 36. Install the camshaft.

9. FLYWHEEL, CRANKSHAFT, AND BEARINGS

Procedures for removal, inspection, and replacement of the flywheel, crankshaft, and bearings are covered here under headings descriptive of the operation. The crankshaft and related parts are shown in fig. 37.

a. Flywheel.

The rear face of the flywheel is used as a friction surface which is engaged by the clutch plate. The flywheel ring gear is secured to the flywheel by means of



1243

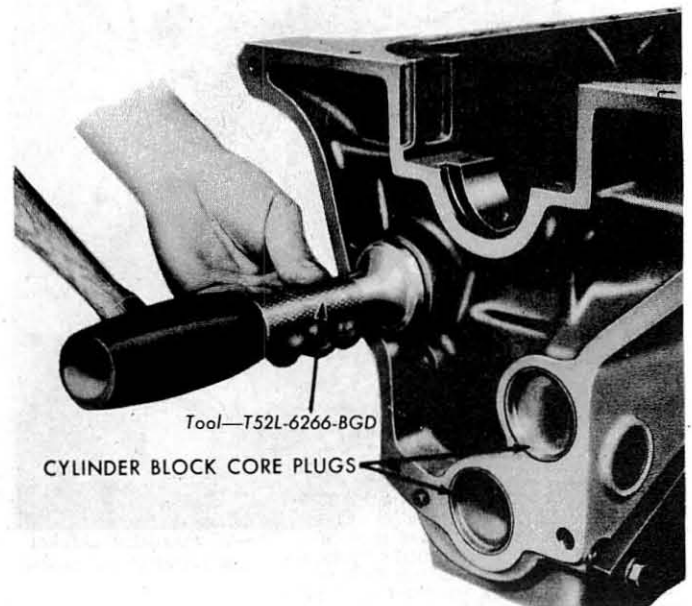

1271

Fig. 36—Installing Camshaft Bore Plug

100% SATISFACTION GUARANTEED

BUY IT NOW!

Click Here To Order

PayPal, American Express, Discover, MasterCard, VISA

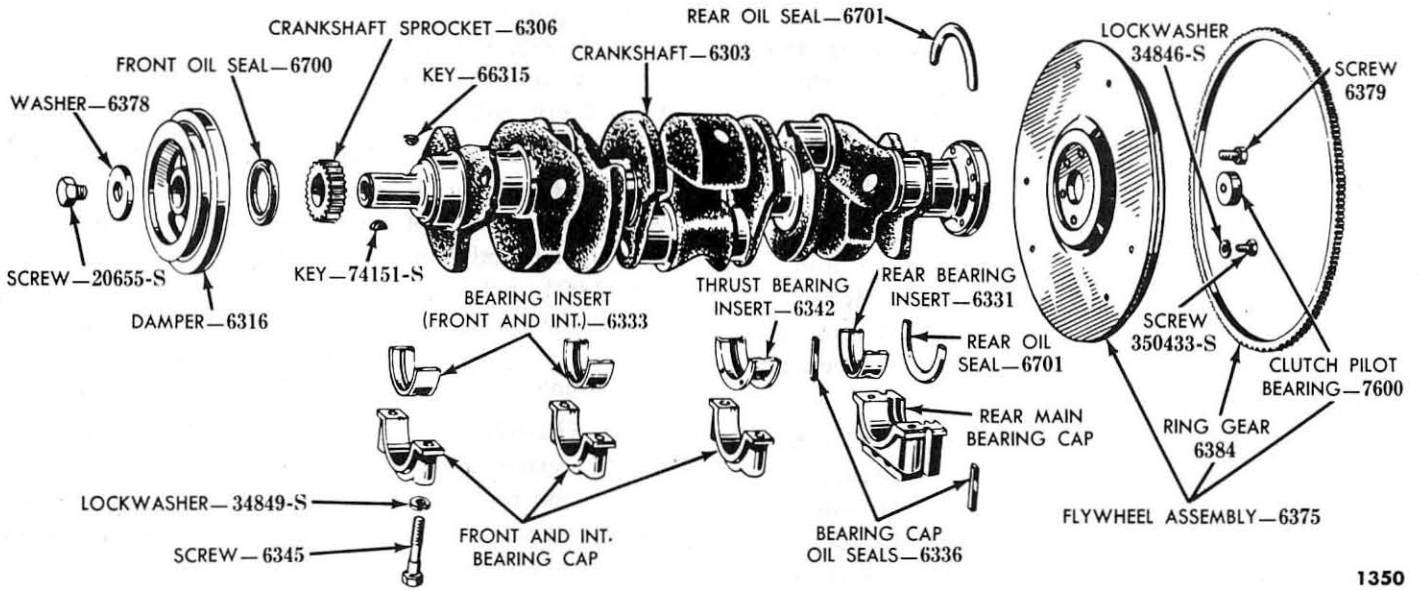

1350

Fig. 37—Crankshaft and Related Parts (Standard Transmission)

Check flywheel runout by mounting a dial indicator as shown in fig. 38. The indicator shaft should contact the outer edge of the clutch plate area. Rotate the flywheel and observe the indicator reading. Total runout should not exceed 0.005 inch.

Examine the ring gear for cracks, damaged teeth or looseness on the flywheel.

(2) **REMOVAL.** Remove the transmission, clutch housing, and the clutch assembly. Remove the flywheel bolts and pull the flywheel off the crankshaft.

(3) **RING GEAR REPLACEMENT.** To remove the old gear, drill a $1\frac{1}{32}$ inch hole nearly through the gear and cut the remaining portion of the gear with a chisel. Heat the new ring gear evenly until the gear expands enough to slip on the flywheel, then position the gear on the flywheel, and allow it to cool. The ring gear run out must not exceed 0.010 inch (fig. 39).

CAUTION: Do not heat any portion of the gear to a temperature higher than 500°F. If this limit is exceeded, the temper will be removed from the gear.

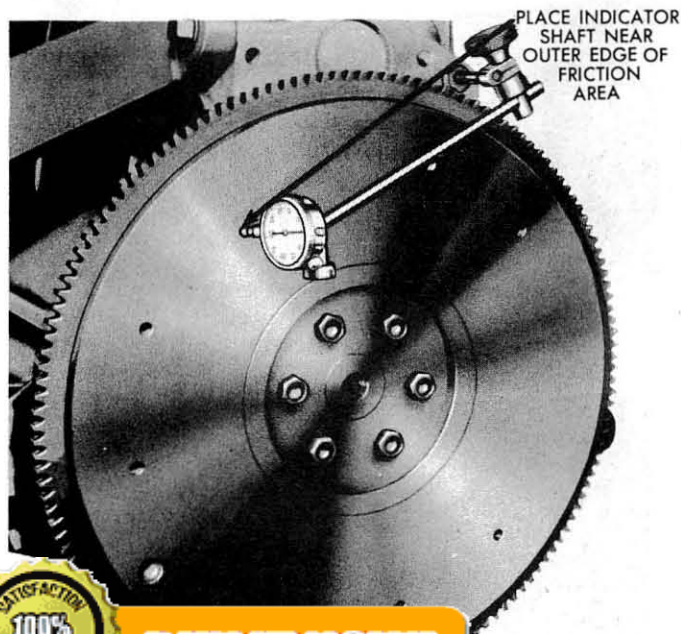

1353

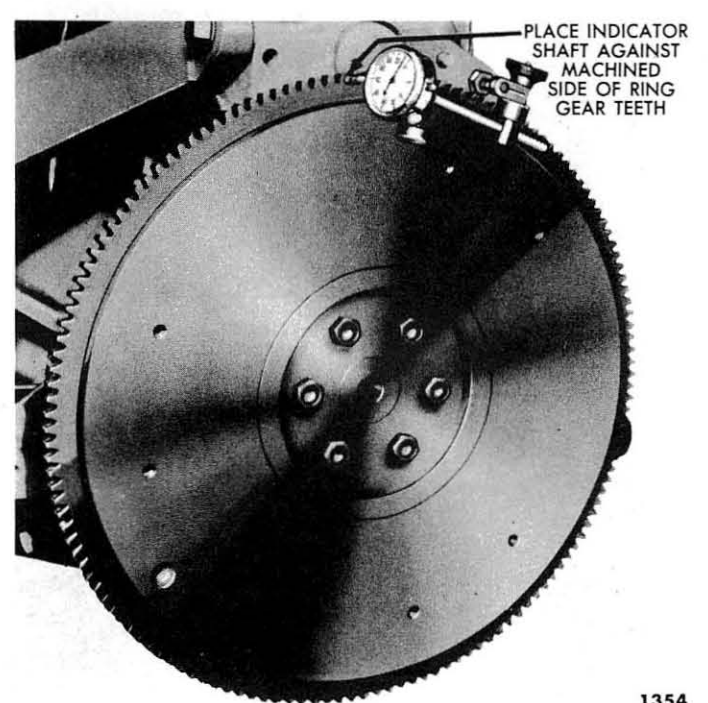

1354

Fig. 39—Checking Ring Gear Run Out

100% SATISFACTION GUARANTEED

BUY IT NOW!

Click Here To Order

PayPal, American Express, Discover, MasterCard, VISA

t (Typical)

(4) **INSTALLATION.** Place the flywheel on the crankshaft flange and install the mounting screws. Torque the screws in sequence across from each other to 75-85 foot-pounds. Install the clutch assembly, clutch housing, and transmission.

b. Crankshaft.

The crankshaft is made of cast nodular iron with integral counterweights and is statically and dynamically balanced. Oil distribution holes are drilled through the shaft to pressure lubricate the main and connecting rod bearings.

(1) **REMOVAL.** Remove the engine and install it on a work stand. Remove the flywheel housing, clutch assembly, starter, and engine rear plate assembly. Remove the flywheel. Remove the damper, front cover, camshaft sprocket and timing chain. Remove the oil pan and the oil pump screen housing assembly.

Make sure all bearing caps are marked so they can be reinstalled in exactly the same position. Remove all connecting rod bearing caps and bearings. Remove the main bearing caps and bearings. Mark all bearings so they can be installed in the same location from which they were removed. Remove the crankshaft. Be careful not to damage the thrust bearing.

(2) **INSPECTION.** Examine the shaft for cracks. Make sure the dowel pins (Fordomatic only) in the flange are not loose or damaged. Grooved or scored main

or crankpin journals will cause bearing failure and should be reground for undersize bearings. Remove light scores or scratches with an oilstone, then polish with No. 320 grit polishing paper.

(3) **MEASURING CRANKSHAFT JOURNALS.** Measure each journal at a minimum of four places to determine size, out of round, and taper. Journals that are out of round more than 0.0015 inch or have more than 0.001 inch taper should be reground. Standard crankshaft journal diameters are: 2.4980-2.4988 inches for main journals and 2.2980-2.2988 inches for crankpin journals.

(4) **REGRINDING CRANKSHAFT.** If it is necessary to regrind the crankshaft, select the next undersize bearing and regrind the journals to give 0.0005-0.0021 inch clearance in the bearings. If it is necessary to regrind the journal diameter more than 0.030 inch, discard the crankshaft.

Always grind the same radii at the ends of the journals as the shaft had originally. Too small a radius will cause fatigue failure of the crankshaft; too large a radius causes bearing failure due to "radius ride" of the bearing.

Use No. 320 grit polishing paper and engine oil to polish the journal after grinding.

(5) **INSTALLATION.** Be sure that all bearing inserts, bores, and the crankshaft journals are clean. Apply a light coat of engine oil to the journals and bearing inserts. Install the inserts in the block. Carefully lower

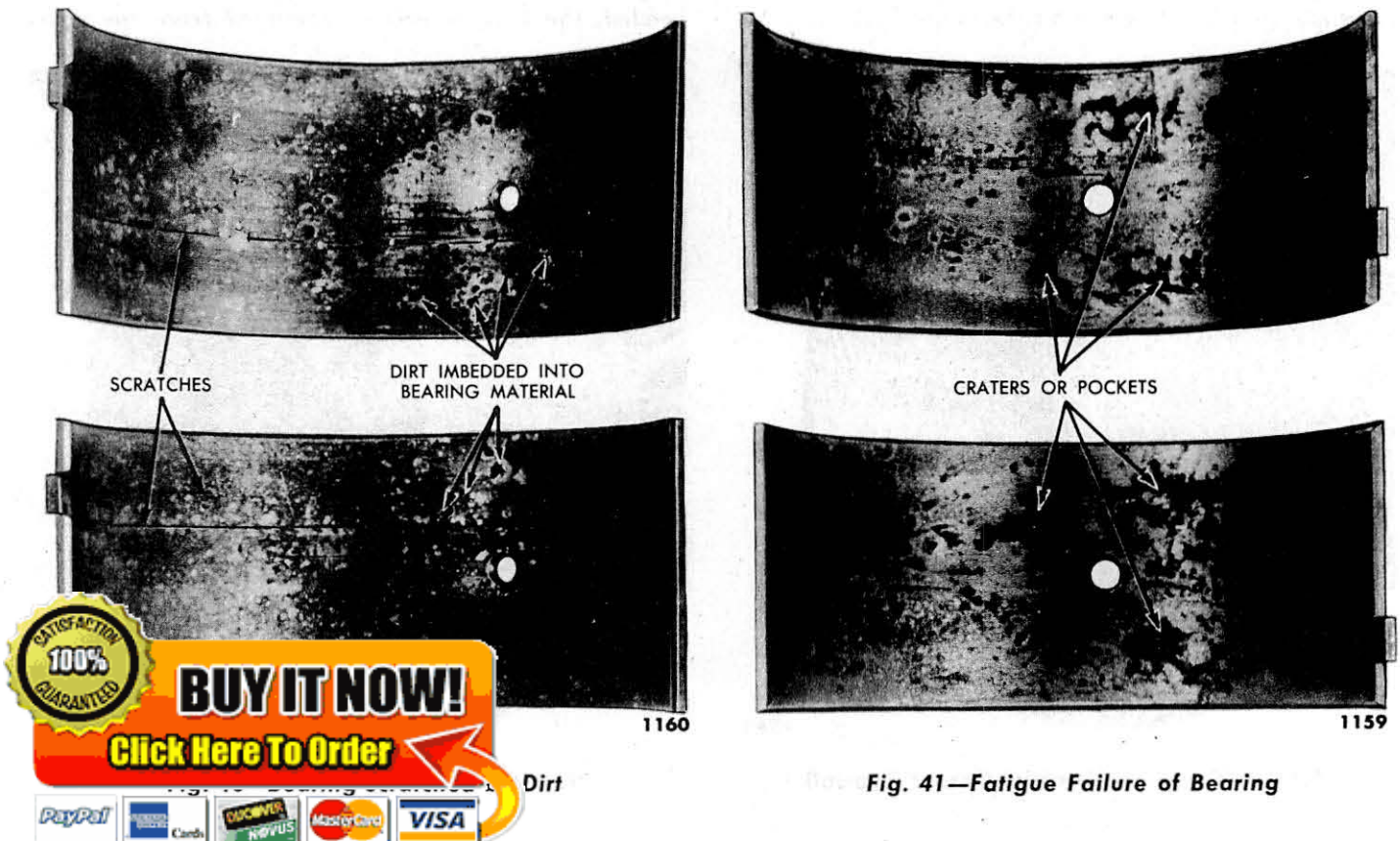

Fig. 41—Fatigue Failure of Bearing

the crankshaft into the bearings. Be careful not to damage the thrust bearing surfaces.

Install the main bearing inserts in the caps and install the caps in the block. Install cap bolts finger tight, pry the crankshaft forward to align the thrust bearing faces, and tighten all bearing cap bolts to 95-105 foot-pounds.

Install the oil pump screen assembly. Install the flywheel (except Fordomatic). Install the clutch assembly, then install the flywheel housing. Install the starter assembly. Install the camshaft sprocket and timing chain. Install the front cover and the crankshaft damper. Install the oil pan. Install the engine in the vehicle.

c. Main Bearings.

Steel-backed tin base babbitt or copper lead inserts are used to support the crankshaft. Care should be used in fitting main bearings to obtain the proper clearance.

Main bearing inserts that are scratched, show fatigue pockets, or have the overlay wiped out, should be replaced.

A bearing that has only light scratches may be re-used providing the clearances are satisfactory. Scratched bearings are shown in fig. 40. Fatigue failure can be recognized by the breaking away of the bearing overlay material (fig. 41). Figure 42 shows two bearings with the overlay wiped out.

A bearing showing signs of excessive wear on one side of the bearing half (fig. 43) indicates a tapered bearing journal. The journal should be reground to the next undersize to remove the taper and undersize bearings installed. Similarly, bearings showing excessive wear at the center or end of the bearing around the cir-

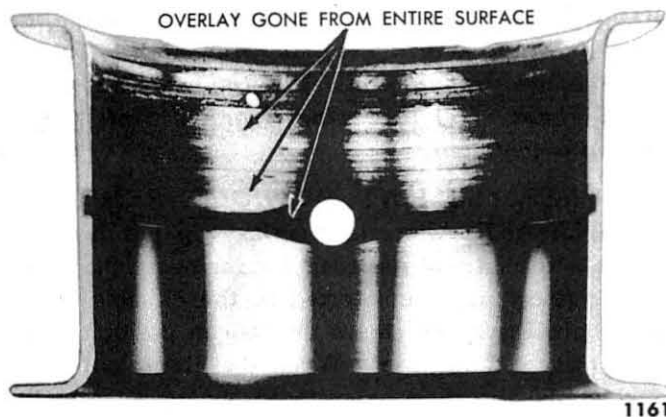

Fig. 43—Bearing Failure Due to Tapered Journal

cumference (fig. 44) indicate high spots on the bearing journal which should be corrected before the engine is rebuilt.

Bearings that show bright sections across the back of the bearing (fig. 45) indicate the bearings have been loose in the bore either because of an undersize outside diameter, or because of the bearing bore being too large, or by the bearing not having sufficient "crush."

Crankshaft end play is controlled by the No. 3 main bearing flanges.

If the crankshaft has been removed, the bearing inserts can be easily replaced. However, the inserts can be removed and replaced without removing the crankshaft.

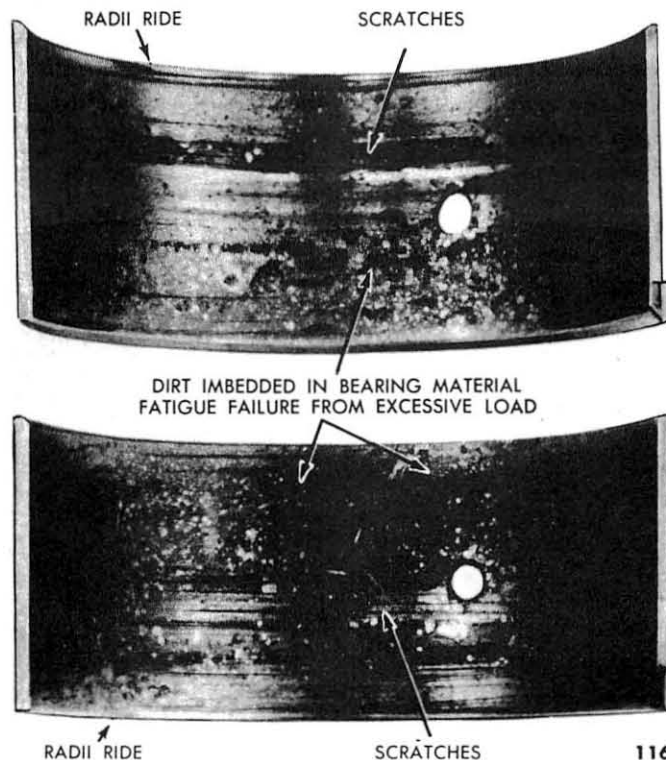

Fig. 44—Bearing Showing Radius Ride

SATISFACTION 100% GUARANTEED

BUY IT NOW!

Click Here To Order

PayPal American Express Discover Novus MasterCard VISA

NOTE: *Special care must be taken when installing the rear main bearing cap to prevent oil leakage past the two sets of seals. Use the procedure presented under “(5) Replacing Rear Oil Seals” when the cap is installed.*

(1) REPLACEMENT WITHOUT REMOVING CRANKSHAFT. After the bearing cap has been removed, a special tool designed for removing the upper bearing insert may be inserted in the oil hole in the crankshaft. Figure 46 shows the tool in position ready to bear against the insert. When the crankshaft is rotated in the direction opposite to engine rotation the tool will force out the bearing insert. This tool should be used with caution to avoid damaging the bearing.

To install the upper main bearing insert, place the plain end of the bearing over the locking tang side of the shaft. Using the same tool, rotate the crankshaft in the direction of engine rotation until the bearing seats itself.

(2) FITTING MAIN BEARINGS (PLASTIGAGE METHOD). If the engine is removed from the vehicle, drain the oil, remove the oil pan and invert the engine. Remove the bearing cap and wipe the oil from the bearing and journal. Keep the other bearing caps tight while checking the fit of a bearing.

NOTE: *If the bearing fit is checked while the engine is in the vehicle it will be necessary to support the weight of the crankshaft. The shaft can be supported by placing a thin rubber pad between the cap insert and journal of two bearings that are not being checked. Tighten these bearing cap bolts enough to hold the crankshaft up against the block half of the main bearing inserts.*

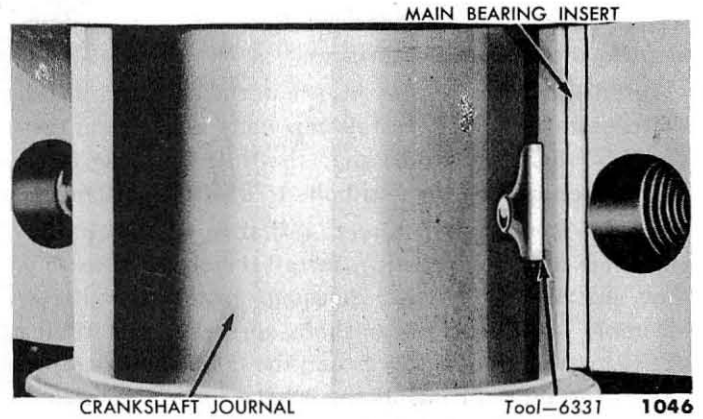

Fig. 46—Removing Main Bearing Insert

Place a piece of Plastigage the full width of the bearing on the journal (or in the bearing cap). Install the bearing cap and tighten the retaining bolts to 95-105 foot-pounds.

CAUTION: *Do not turn the crankshaft while the Plastigage is between the bearing and the journal.*

Remove the bearing cap. Without moving the plastic, check its width (at the widest point) with the graduations on the Plastigage container as shown in fig. 47.

NOTE: *Normally, main bearing journals wear evenly and are not out-of-round. However, if a bearing is being fitted to an out-of-round journal, be sure to fit the bearing to the maximum diameter of the journal. If the bearing is fitted to the minimum clearance of 0.0005 on the minimum diameter of the journal, and the journal is out-of-round 0.0005 or more, interference between the journal and bearing will result in rapid failure of the bearing.*

If the bearing clearance is not over 0.0021 inch or less than 0.0005 inch, the bearing insert is satisfactory. If the clearance is not within limits, try the selective

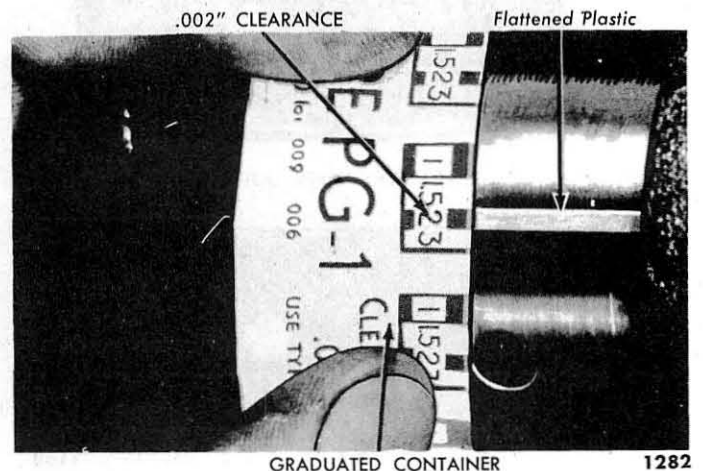

Fig. 47—Measuring Flattened Plastigage

100% SATISFACTION GUARANTEED

BUY IT NOW!

Click Here To Order

Spots Due To

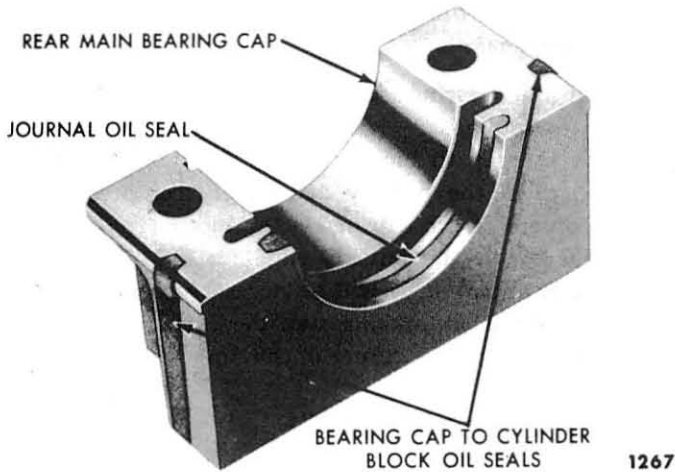

Fig. 48—Rear Bearing Cap Seals

fit bearing to bring the clearance within the 0.0005-0.0021 inch limit. If the selective fit bearings do not bring the clearance below 0.0021 inch, it will be necessary to re-grind the crankshaft journals for use with the next undersize bearing.

NOTE: *If the flattened plastic is not uniform in width from end to end, the journal or bearing is tapered. Be sure to check the journal with micrometers if the flattened plastic indicates more than 0.001 inch difference.*

(3) **CHECKING CRANKSHAFT END PLAY.** To check the crankshaft end play, push the crankshaft toward the rear of the engine. Place a dial indicator against the rear side of the crankshaft flange. Set the dial to zero, then push the crankshaft forward.

If the dial indicator shows more than 0.008 inch or less than 0.004 inch play, the main thrust bearing insert should be replaced with a new insert to obtain proper end play. The manufacturer's crankshaft end clearance is 0.004-0.008 inch.

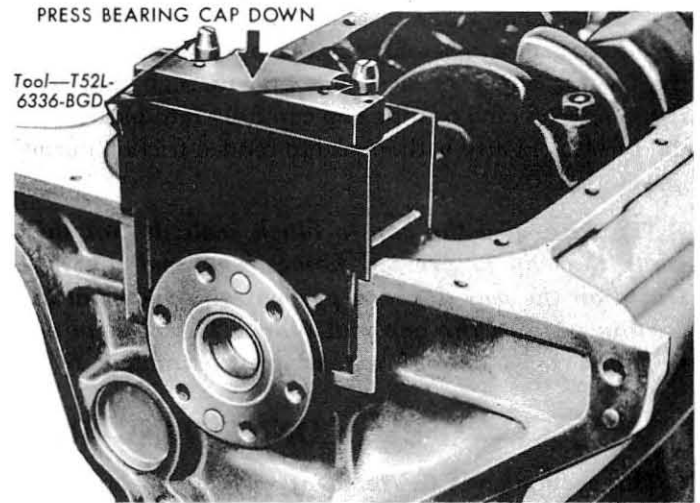

Fig. 50—Installing Rear Bearing Cap

(4) **REPLACING REAR OIL SEALS.** The rear main bearing cap contains the lower crankshaft journal oil seal and the cap itself is sealed to the block by two tapered vertical seals (fig. 48).

Be sure to use the seal forming tool and the bearing cap guide fixture when installing the seals and cap.

Remove the crankshaft. Remove the rear bearing inserts. Pry out the old seals from the rear bearing cap and block. Clean the seal grooves thoroughly.

Install a new journal oil seal in the bearing cap groove. Form the seal and cut it off flush with the edge of the tool as shown in fig. 49. Use a sharp knife and leave no ragged edges.

Repeat the procedure to form the upper half of the seal in the cylinder block groove. Install the bearing inserts. Lay the crankshaft in the block bearing halves, using care not to damage the thrust bearing flanges.

Install the bearing cap with seals into the fixture. The seals must be even with the parting edge of the cap.

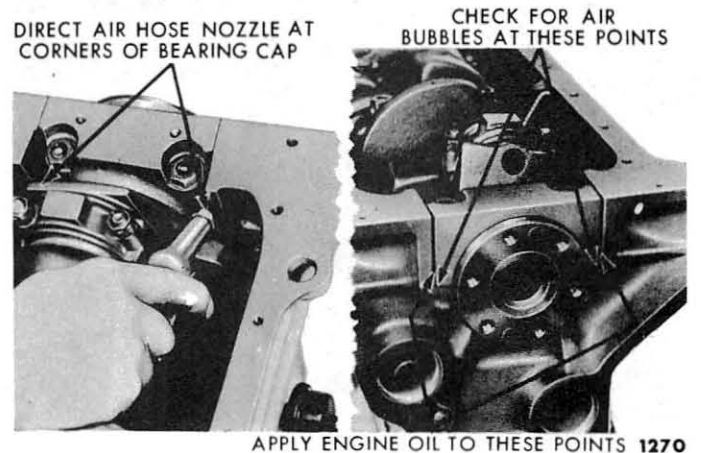

Fig. 51—Checking Seal for Leakage

SATISFACTORY 100% GUARANTEED

BUY IT NOW!

[Click Here To Order](#)

TOOL 1268

Oil Seal

Install the pilot studs in the block. Place the bearing caps and fixture assembly on the pilot studs and slide the bearing cap over the studs and through the guide (fig. 50). Press the bearing cap carefully into place. Coat the surfaces lightly with grease to reduce friction during installation.

NOTE: *Be sure the cap to block seals do not shift while the cap is pressed home. The seal must be seated all the way down to prevent oil leakage at the parting edge of the cap and block. The vertical cap to block seals should extend approximately 3/64*

inch above the block to insure a good seal against the oil pan gasket.

Install the bearing cap bolts and torque them to 95-105 foot-pounds.

Check the cap to block seals by applying oil to the outer edges of the bearing cap. Apply compressed air to the corners of the cap inside the block (fig. 51) and check the oil at the outside edge for bubbles. If any bubbling is apparent, it will be necessary to remove the cap and reinstall it, making sure the cap to block seals seat all the way to the corner of the cap.

10. CONNECTING RODS, PISTONS, AND RINGS

This section gives the removal, inspection, and installation procedures for connecting rods, pistons, and pins. Complete data is given on the fitting of all bearings and the fitting of new rings and pistons.

a. Remove Piston and Connecting Rod Assemblies.

Remove the oil pan and cylinder head.

Before removing a piston from the engine, remove any ridges that may be present along the upper part of each cylinder as follows:

Move the piston to the bottom of its travel and place a cloth on the piston head to collect the cuttings. Position the ridge remover in the cylinder and adjust the ridge remover pilot to the cylinder size. Make sure the cutter is at the top side of the roller bar and that the cutter does not extend beyond the roller. Make sure the ridge remover shoes are tight. Hold the ridge remover

tightly against the block and turn the arbor clockwise with a tee handle wrench (fig. 52).

CAUTION: *Never cut into the ring travel area more than 1/32 inch when removing ridges.*

Remove the ridge remover from the cylinder bore. Turn the crankshaft until the piston is at the top of its stroke and carefully remove the cloth with the cuttings from the piston head. Clean the carbon from the piston head and cylinder block before removing the piston from the bore.

Turn the crankshaft until the rod of the piston being removed is down. Remove the nuts from the connecting rod bolts. Lift the rod bearing cap from the rod and push the rod and piston assembly out of the top of the cylinder with the handle end of a hammer. Do not scratch the crankpin or the cylinder wall when removing the piston and rod. Repeat this procedure for each assembly.

NOTE: *Each rod and bearing cap is numbered from 1 to 6 beginning at the timing gear end of the engine. The numbers on the rod and bearing cap must be on the same side when re-installing them into*



Fig. 53—Removing Rings

100% SATISFACTION GUARANTEED

BUY IT NOW!

Click Here To Order

PayPal American Express Discover MasterCard VISA

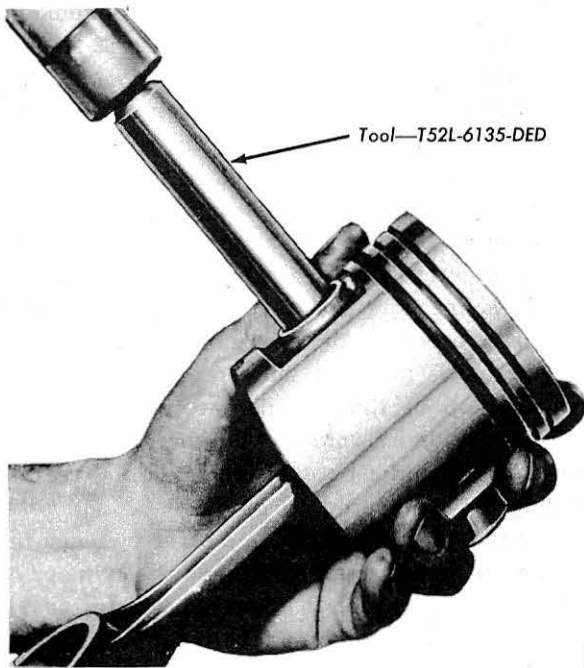

1273

Fig. 54—Removing Piston Pin

their respective cylinder bores. If a connecting rod is ever transposed from one block or cylinder to another, make sure all the bearings are new and that the number on the rod is restamped to correspond with the new cylinder number.

b. Disassembly of Piston and Connecting Rod Assemblies.

Mark the pistons for identification of the piston with the bore and rod for assembling purposes.

Remove the piston rings with the tool shown in fig. 53. Remove the piston pin retainers at each end of the piston pin. Drive the piston pin out of the piston (fig. 54).

Remove the rod bearing cap and the bearing inserts after identifying the inserts for reassembly with the same rod and cap, if the inserts are to be re-used. The piston and rod is shown disassembled in fig. 55.

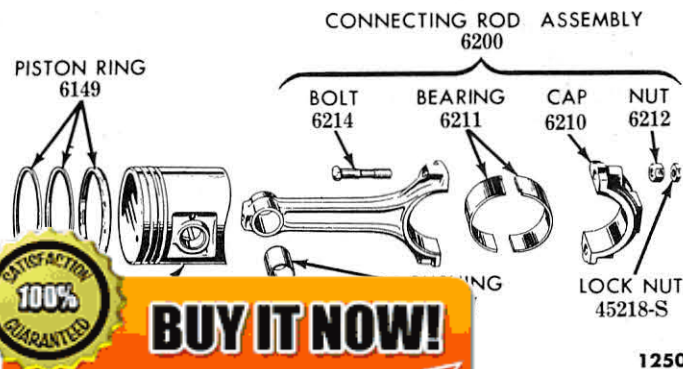

1250

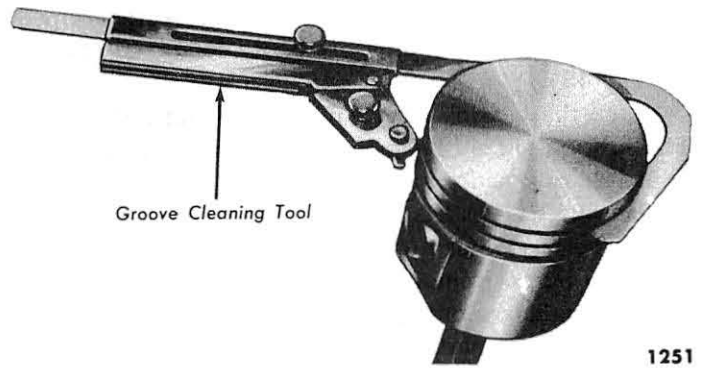

1251

Fig. 56—Cleaning Ring Grooves

c. Cleaning Piston and Connecting Rod Assemblies.

Clean the piston ring grooves with a ring groove cleaner (fig. 56).

Clean all the parts and passages in solvent. Never use caustic cleaning solution. Thoroughly clean the rod bore and the back of the inserts.

d. Inspection of Piston and Connecting Rod Assemblies.

Connecting rod bolts or nuts with damaged threads, and rods with deep nicks, signs of fractures, scored bore, or bore out of round more than 0.002 inch should be replaced.

Use a new piston pin to check the piston pin bushing in the connecting rod for wear. The pin should have a 0.0001-0.0003 inch clearance in the rod bushing. If the new pin falls through the bore by its own weight, ream the bushing for the next oversize pin or replace the connecting rod.

Check every connecting rod for alignment on a fixture after fitting the piston pins (fig. 57). If the rod is twisted more than 0.012 inch or bent more than 0.004 inch, it should be straightened or replaced.



1253

Fig. 57—Check Connecting Rod Alignment

100% SATISFACTORY GUARANTEED

BUY IT NOW!

Click Here To Order

PayPal, American Express, Discover, MasterCard, VISA

(1) **CONNECTING ROD BEARINGS.** Replace bearing inserts that are scored, have the overlay wiped out, show fatigue failure, or are badly scratched (fig. 40 through 45).

Install the bearing inserts in the cap and rod section. The bearing should snap into place and remain there. If the bearing slides in freely and will fall out readily, the bearing has lost its spread and should be replaced. Check the inside edge of the bearing at the parting line for sharp burrs. Remove the burrs if any are apparent. The parting edges of the bearings should be free of dirt or other foreign particles.

(2) **PISTONS.** Inspect pistons for fractures at the ring lands, skirt, and pin bosses. Replace pistons showing signs of excessive skirt clearance, wavy ring lands, fractures, or damage from detonation. Spongy eroded areas near the edge of the piston top are caused by detonation. In some instances holes are also burned through the piston top.

(3) **PISTON PINS.** Replace piston pins showing signs of fractures or etching. Piston pins that show wear or fit loose in the piston or rod bushing should be replaced. Replace all piston pin retainers.

(4) **CYLINDER BLOCK.** Make a thorough check for cracks. Minute cracks not visible to the naked eye may be detected by coating the suspected area with a mixture of 25% kerosene and 75% light motor oil. Wipe the part dry and immediately apply a white coating of zinc oxide dissolved in wood alcohol. If cracks are present, the white coating will become discolored at the defective area.

Inspect the cylinder bores for scoring. Inspect the expansion plugs for rust at the edge of the plug. Rust indicates leakage. If leakage is indicated, drill a 1/2" hole in the plug, then remove the plug with the tool shown in fig. 34. Install a new plug with the tool shown in fig. 36. Always use a sealer when installing new plugs or leakage may result.

Check the cylinder bore for taper, out of round, and wear with a cylinder bore gauge, telescope gauge, or inside micrometers. Only experienced personnel should be permitted to take these measurements.

Record measurements taken lengthwise and crosswise at the top and bottom of the block as follows:

Lengthwise of the block, measure and record as "A" the diameter of the cylinder at the top of the cylinder where the greatest ring wear occurs. Also lengthwise of the block, measure and record as "B" the cylinder diameter at the bottom of the piston skirt travel. Crosswise of the block, measure and record as "C" the diameter of the top of the cylinder at the greatest wear point. Measure and record as "D" the diameter at the bottom of the cylinder bore, also crosswise of the block.

Reading "A" compared to reading "B" and reading "C" compared to reading "D" indicates cylinder taper. If the taper is greater than 0.015 inch the cylinder must be rebored and honed for the next oversize piston. However, a cylinder rebores should be recommended if the cylinder taper exceeds 0.008 inch.

Reading "A" compared to reading "C" and reading "B" compared to reading "D" indicates whether or not the cylinder is out of round. If the out of round exceeds 0.003 inch, the cylinders must be rebored and honed for the next oversize piston.

Measuring the cylinder bore with a telescope gauge is illustrated in fig. 58.

e. Fitting Pistons.

Proper assembly tolerances of pistons are required if satisfactory engine operation is to be obtained. Cylinder bores must be checked for taper and out of round condition before fitting a piston.

Before installing a piston and new rings in a used block, remove the high polish on the cylinder wall to aid ring seating by passing a hone or glaze removing tool through the cylinder bore a few times. Do not hone more than enough to rough up the polish. Make sure that oiled rags are placed in the bore to catch the hone grit and that the cylinder is thoroughly cleaned before installing the piston.

To fit a new piston in a new bore, attach a tension scale to the end of a feeler ribbon 1/2 inch wide and having the correct feeler ribbon thickness as given in Table 1.

Table 1—Piston Fitting Specifications

Fit New Piston In New Bore		Fit New Piston In Used Bore		Fit Used Piston In Used Bore	
Gauge Thickness (Inch)	Pounds Pull	Gauge Thickness (Inch)	Pounds Pull	Gauge Thickness (Inch)	Pounds Pull
0.0015	5-10	0.002	5-10	0.003	5-10



1254

Bore

100% SATISFACTION GUARANTEED

BUY IT NOW!

Click Here To Order

PayPal, American Express, Discover, MasterCard, VISA

Position the feeler ribbon on the side of the piston 90° from the piston pin hole. Invert the piston, then push the piston and feeler gauge in the cylinder so the end is about ½ inch below the top of the block. Keep the piston pin bores parallel with the crankshaft axis. Pull out the feeler gauge while noting the scale reading (fig. 59).

The pull limits for new pistons and used pistons in new or used bores is given in Table 1.

If the scale reading is greater than the maximum allowable pull, try another piston or hone the cylinder bore to obtain the proper fit. If the scale reading is less than the minimum allowable pull, try another piston. If none can be fitted, rebore the cylinder to the next over size piston.

f. Boring Cylinder Block.

To assure maximum engine performance and balance of the reciprocating parts of the engine, *all* cylinders must be bored to the same size when the 0.060 inch piston must be installed even though only one cylinder requires reboring and the others are within tolerance. Manufacturers recommendations on how to use boring equipment should be followed and the work performed only by experienced personnel.

Bore the cylinder with the most wear first to determine the proper oversize. If the cylinders will not clean up at 0.060 inch oversize, the block must be replaced.

When reboring the cylinders allow 0.0015 inch stock for honing to a final finish. Use a number 220 to 280 grit hone for this operation.

CAUTION: *Thoroughly clean the block to remove all particles of abrasive after the honing operation.*

g. Fitting Piston Pins.

Check the piston pin fit in the piston. Piston pins must be a hand-push fit in the piston pin bore at normal room temperature (70°F.).

If oversize piston pins are to be used, or if the piston pins are too tight, ream the pin bore with an expansion type piston pin bore reamer. Place the reamer in a vise and revolve the piston around the reamer.

Set the reamer to the size of the piston pin bore, then expand the reamer very slightly and trial ream the bore in the piston using a pilot sleeve of the nearest size to maintain alignment of the piston pin bores.

CAUTION: *Take a very light cut.*

Check the reamed hole size using the new piston pin to be used in the piston being reamed as a gauge. If the bore is small, expand the reamer slightly and make another trial cut. Repeat the procedure outlined until a piston pin fit is obtained.

Similarly ream all the pistons in which pins need to be fitted, checking each with the pin to be used in the piston. Repeat the procedure to fit the pins to the connecting rod bushings.

h. Fitting Piston Rings.

Install the piston ring in the cylinder bore. Invert the piston and use the top to push the ring about halfway into the bore to true the ring with the cylinder bore. Measure the ring gap with a feeler gauge. The gap should be 0.007-0.047 inch (all rings). If the gap is less than the minimum limit, remove the ring and file the ends until the proper clearance is obtained.

After the rings have been fitted in the cylinder bore, they should be installed on the piston or identified with

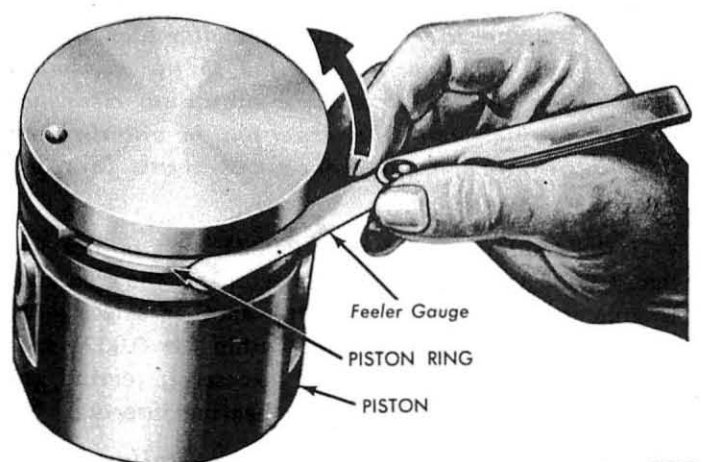

Fig. 60—Checking Ring Clearance

the piston and cylinder bore in which they are to be installed.

Check the ring to groove clearance with the rings to be used on the piston as shown in fig. 60.

The rings should have the following clearance:

Ring	Clearance in Piston Groove (inch)
Top Compression	0.0020-0.0035
2nd Compression	0.0015-0.0030
Oil Ring	0.0010-0.0025

Three different type rings are available in sets for service, the standard ring, the expander ring, and the steel section ring.

The standard (snap type) is designed for use in a new engine.

The expander type is designed for use, after a light honing operation, in a cylinder bore with a small amount of taper, to correct an oil consumption condition.

The steel section type ring should be used in cylinders where the taper of the cylinder bore is very great, or to correct excessive oil consumption conditions when the customer does not want the cylinders rebored.

Bore "glaze" should be removed to aid piston ring seating.

i. Fitting Connecting Rod Bearings (Plastigage Method).

Place a piece of Plastigage plastic the length of the insert in the bearing insert. Install the cap and tighten to 45-50 foot-pounds.

NOTE: Do not turn the crankshaft with Plastigage in place.

Remove the bearing cap and use the Plastigage scale to measure the width of the flattened piece of plastic at the widest point.

NOTE: If the crankpin is out-of-round, be sure to fit the bearing to the maximum diameter of the crankpin. If the bearing is fitted to the minimum diameter of the crankpin with minimum clearance of 0.0005 inch and the crankpin is out-of-round 0.0005 or more, interference will result in rapid failure of the bearing.

If the reading is not over 0.0021 inch or not less than 0.0005 inch, the fit is satisfactory. If the clearance is greater than 0.0021 inch, try another selective fit bearing to bring the clearance within the 0.0021 inch range. If the clearance is still excessive, regrind the crankpin and bearing inserts.

eters for taper if the flattened plastic indicates more than 0.001 inch difference.

Rotate the crankshaft after the bearing is installed to be sure the bearing is not too tight.

j. Assembly.

Lubricate all parts with light engine oil.

NOTE: The oil squirt hole should be toward the valve side of the cylinder bore when assembly is installed.

Position the connecting rod in the piston and push the pin into place.

Insert new piston pin retainers by spiralling them into the piston with the fingers. Do not use pliers. Install the piston rings.

Insert the bearing halves in the rod and cap.

k. Installation.

Oil the cylinder wall with light engine oil. Make sure the ring gaps are equally spaced around the circumference of the piston. Compress the rings with a compressing tool and push the piston down with a hammer handle (fig. 61) until it is slightly below the top of the cylinder.

NOTE: Install the piston with the indentation in the piston head toward the front of the engine.

Turn the crankshaft throw to the bottom of its stroke. Oil the crankpin and push the piston all the way down until the rod bearing seats on the crankpin. Be careful not to scratch the cylinder bore or the crankpin. Install the bearing cap (line up the stamped numbers) and tighten the retaining nuts to 45-50 foot-pounds torque. Install new pal nuts and tighten the nuts to 3-3½ foot-pounds torque (or finger tight plus 1/3 turn).

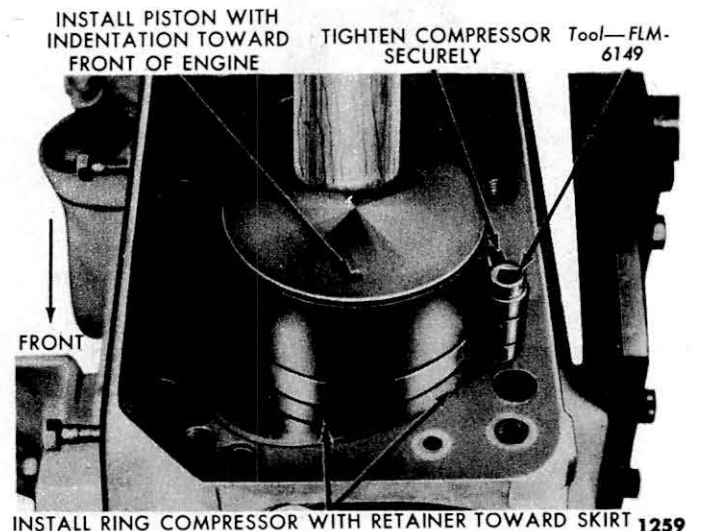

Fig. 61—Installing Piston

100% SATISFACTION GUARANTEED

BUY IT NOW!

Click Here To Order

not uniform from
al or bearing is
! with microm-

PayPal, American Express, Discover, MasterCard, VISA

Install the oil pan and cylinder heads. Fill the crankcase with the proper grade and amount of lubricant. Fill the cooling system. Start the engine and run it at idle

speed. Make sure there is sufficient oil pressure. Check the temperature to make sure the engine does not overheat.

11. EXHAUST SYSTEM

The exhaust system on the 6-cylinder car consists of a muffler, an exhaust outlet pipe, and a muffler inlet pipe (fig. 62).

The following procedure covers the removal and installation of units of the exhaust system.

NOTE: After replacing any part of the exhaust system, it is advisable to loosen all the frame attaching bracket clamps to relieve twists in the system and then retighten the clamps.

a. Muffler Replacement.

Extra heavy, double-wall construction mufflers are available for service.

(1) **REMOVAL.** Loosen muffler inlet and outlet pipe clamps. Slide clamps away from the muffler, the inlet pipe, and the outlet pipe. Loosen front and rear outlet pipe clamps and disengage the outlet pipe from the muffler by sliding the outlet pipe to the rear. Remove the muffler from the inlet pipe.

(2) **INSTALLATION.** Place the muffler in position on the inlet pipe and slide the outlet pipe into the muffler. Place the inlet pipe and outlet pipe clamps in position on the muffler and tighten clamps. Tighten the front and rear-outlet pipe clamps.

b. Outlet Pipe Replacement.

The outlet pipe is attached to the frame by flexible sound deadening materials which not only prevent the exhaust noises from being conducted through the chassis

frame but also relieve the exhaust system from twisting or bending stresses.

(1) **REMOVAL.** Loosen the muffler outlet pipe clamp, leaving the clamp on the muffler. Remove the outlet pipe front and rear support clamps and disengage the outlet pipe from the muffler.

(2) **INSTALLATION.** Position the outlet pipe in the muffler and tighten the clamp. Place the outlet pipe rear support bracket clamp on the outlet pipe. Install the front support bracket clamp and tighten the nut. Position the rear outlet pipe clamp on the rear bracket and tighten the nut.

c. Inlet Pipe Replacement.

The muffler inlet pipe is designed to give the exhaust gases leaving the exhaust manifolds a direct through passage to the muffler, thereby increasing the over-all efficiency of the exhaust system.

(1) **REMOVAL.** Loosen the muffler inlet pipe clamp. Remove the two nuts holding the inlet pipe to the exhaust manifold, then remove the gasket. Disengage the inlet pipe from the muffler by sliding the inlet pipe forward.

(2) **INSTALLATION.** Place the inlet pipe in the muffler. Install a new gasket on the exhaust outlet flange studs. Slide the inlet pipe flange over the studs and secure the pipe to the exhaust manifold with the two nuts and lockwashers. Tighten the nuts to 23-28 foot-pounds. Tighten the muffler inlet pipe clamp.

